



FCC RF Test Report

APPLICANT : Sony Mobile Communications Inc.
EQUIPMENT : GSM/WCDMA/LTE Phone+Bluetooth, DTS/UNII
a/b/g/n/ac and NFC
BRAND NAME : Sony
FCC ID : PY7-67442A
STANDARD : FCC Part 15 Subpart C §15.247
CLASSIFICATION : (DTS) Digital Transmission System

This is a variant report which is only valid together with the original test report. The product was received on Jun. 27, 2017 and testing was completed on Nov. 01, 2017. We, SPORTON INTERNATIONAL INC., would like to declare that the tested sample has been evaluated in accordance with the test procedures and has been in compliance with the applicable technical standards.

The test results in this report apply exclusively to the tested model / sample. Without written approval of SPORTON INTERNATIONAL INC., the test report shall not be reproduced except in full.

Reviewed by: Joseph Lin / Supervisor

Approved by: Jones Tsai / Manager



SPORTON INTERNATIONAL INC.

No. 52, Hwa Ya 1st Rd., Hwa Ya Technology Park, Kwei-Shan District, Tao Yuan City, Taiwan, R.O.C.

SPORTON INTERNATIONAL INC.

TEL : 886-3-327-3456

FAX : 886-3-328-4978

FCC ID : PY7-67442A

Page Number : 1 of 17

Report Issued Date : Nov. 07, 2017

Report Version : Rev. 01

Report Template No.: BU5-FR15CWL Version 2.0



TABLE OF CONTENTS

REVISION HISTORY.....3

SUMMARY OF TEST RESULT4

1 GENERAL DESCRIPTION5

 1.1 Applicant5

 1.2 Manufacturer.....5

 1.3 Product Feature of Equipment Under Test.....5

 1.4 Modification of EUT5

 1.5 Testing Location6

 1.6 Applicable Standards.....6

2 TEST CONFIGURATION OF EQUIPMENT UNDER TEST7

 2.1 Carrier Frequency and Channel7

 2.2 Test Mode.....7

 2.3 Connection Diagram of Test System.....8

 2.4 EUT Operation Test Setup8

3 TEST RESULT9

 3.1 Output Power Measurement.....9

 3.2 Radiated Band Edges and Spurious Emission Measurement10

 3.3 Antenna Requirements14

4 LIST OF MEASURING EQUIPMENT15

5 UNCERTAINTY OF EVALUATION17

APPENDIX A. CONDUCTED TEST RESULTS

APPENDIX B. RADIATED SPURIOUS EMISSION

APPENDIX C. RADIATED SPURIOUS EMISSION PLOTS

APPENDIX D. DUTY CYCLE PLOTS

APPENDIX E. ORIGINAL REPORT



REVISION HISTORY

| REPORT NO. | VERSION | DESCRIPTION | ISSUED DATE |
|--------------|---------|-------------------------|---------------|
| FR762714-01C | Rev. 01 | Initial issue of report | Nov. 07, 2017 |
| | | | |
| | | | |
| | | | |
| | | | |
| | | | |
| | | | |
| | | | |
| | | | |
| | | | |
| | | | |
| | | | |
| | | | |
| | | | |
| | | | |
| | | | |
| | | | |
| | | | |



SUMMARY OF TEST RESULT

| Report Section | FCC Rule | Description | Limit | Result | Remark |
|----------------|--------------------|--|-----------------------|--------|-----------------------------------|
| 3.1 | 15.247(b) | Power Output Measurement | $\leq 30\text{dBm}$ | Pass | - |
| 3.2 | 15.247(d) | Radiated Band Edges and Radiated Spurious Emission | 15.209(a) & 15.247(d) | Pass | Under limit 3.89 dB at 32.160 MHz |
| 3.3 | 15.203 & 15.247(b) | Antenna Requirement | N/A | Pass | - |



1 General Description

1.1 Applicant

Sony Mobile Communications Inc.

4-12-3 Higashi-Shinagawa, Shinagawa-ku, Tokyo, 140-0002, Japan

1.2 Manufacturer

Sony Mobile Communications Inc.

4-12-3 Higashi-Shinagawa, Shinagawa-ku, Tokyo, 140-0002, Japan

1.3 Product Feature of Equipment Under Test

GSM/WCDMA/LTE, Bluetooth, DTS/UNII a/b/g/n/ac, FM Receiver, NFC, and GPS.

| Standards-related Product Specification | |
|---|--------------------------------------|
| Antenna Type / Gain | Monopole Antenna with gain -1.50 dBi |

Remark: This is a variant report. All the test cases were performed on original report which can be referred to Sporton Report Number FR762713-01C.

| EUT Information List | | | |
|----------------------|------------|------------|--|
| HW Version | SW Version | S/N | Performed Test Item |
| A | 2.27 | CQ300001SC | RF conducted measurement Radiated Spurious Emission |

| Accessory List | |
|----------------|--------------------|
| AC Adapter | Model Name: UCH12 |
| | S/N: VB17W34100228 |
| Earphone 1 | Model Name: MH410c |
| | S/N: N/A |
| USB Cable | Model Name: UCB20 |
| | S/N: N/A |

Note:

1. Above EUT list and accessory list used are electrically identical per declared by manufacturer.
2. Above the accessories list are used to exercise the EUT during test.
3. For other wireless features of this EUT, test report will be issued separately.

1.4 Modification of EUT

No modifications are made to the EUT during all test items.



1.5 Testing Location

Sporton Lab is accredited to ISO 17025 by Taiwan Accreditation Foundation (TAF code : 1190) and the FCC designation No. TW1190 and TW0007 under the FCC 2.948(e) by Mutual Recognition Agreement (MRA) in FCC Test.

| | |
|---------------------------|--|
| Test Site | SPORTON INTERNATIONAL INC. |
| Test Site Location | No. 52, Hwa Ya 1 st Rd., Hwa Ya Technology Park, Kwei-Shan District, Tao Yuan City, Taiwan, R.O.C. TEL: +886-3-327-3456 FAX: +886-3-328-4978 |
| Test Site No. | Sporton Site No. |
| | TH05-HY |

Note: The test site complies with ANSI C63.4 2014 requirement.

| | |
|---------------------------|--|
| Test Site | SPORTON INTERNATIONAL INC. |
| Test Site Location | No.58, Aly. 75, Ln. 564, Wenhua 3rd Rd. Guishan Dist, Taoyuan City, Taiwan (R.O.C.) TEL: +886-3-327-0868 FAX: +886-3-327-0855 |
| Test Site No. | Sporton Site No. |
| | 03CH13-HY |

Note: The test site complies with ANSI C63.4 2014 requirement.

1.6 Applicable Standards

According to the specifications of the manufacturer, the EUT must comply with the requirements of the following standards:

- FCC Part 15 Subpart C §15.247
- FCC KDB Publication No. 558074 D01 DTS Meas. Guidance v04
- ANSI C63.10-2013

Remark:

1. All test items were verified and recorded according to the standards and without any deviation during the test.
2. This EUT has also been tested and complied with the requirements of FCC Part 15, Subpart B, recorded in a separate test report.



2 Test Configuration of Equipment Under Test

- a. The EUT has been associated with peripherals and configuration operated in a manner tended to maximize its emission characteristics in a typical application. Frequency range investigated: radiation emission (9 kHz to the 10th harmonic of the highest fundamental frequency or to 40 GHz, whichever is lower). Pre-scanned tests, X, Y, Z in three orthogonal panels, and different data rates were conducted to determine the final configuration (Z plane as worst plane) from all possible combinations.

2.1 Carrier Frequency and Channel

| Frequency Band | Channel | Freq. (MHz) | Channel | Freq. (MHz) |
|-----------------|---------|-------------|---------|-------------|
| 2400-2483.5 MHz | 1 | 2412 | 7 | 2442 |
| | 2 | 2417 | 8 | 2447 |
| | 3 | 2422 | 9 | 2452 |
| | 4 | 2427 | 10 | 2457 |
| | 5 | 2432 | 11 | 2462 |
| | 6 | 2437 | - | - |

2.2 Test Mode

Final test mode of conducted test items and radiated spurious emissions are considering the modulation and worse data rates as below table.

| Modulation | Data Rate |
|----------------|-----------|
| 802.11b | 1 Mbps |
| 802.11ac VHT20 | MCS0 |

2.3 Connection Diagram of Test System

<WLAN Tx Mode>

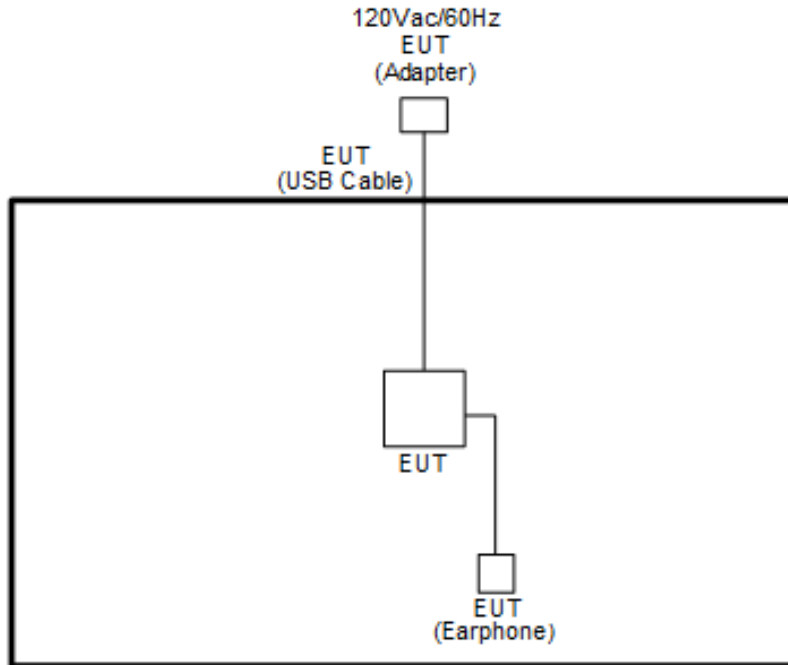

2.4 EUT Operation Test Setup

For RF test items, an engineering test program was provided and enabled to make EUT transmitting signals.

3 Test Result

3.1 Output Power Measurement

3.1.1 Limit of Output Power

For systems using digital modulation in the 2400-2483.5MHz, the limit for peak output power is 30dBm. If transmitting antenna of directional gain greater than 6dBi are used the peak output power from the intentional radiator shall be reduced below the above stated value by the amount in dB that the directional gain of the antenna exceeds 6 dBi. In case of point-to-point operation, the limit has to be reduced by 1dB for every 3dB that the directional gain of the antenna exceeds 6dBi.

3.1.2 Measuring Instruments

The measuring equipment is listed in the section 4 of this test report.

3.1.3 Test Procedures

1. The testing follows the Measurement Procedure of FCC KDB No. 558074 DTS D01 Meas. Guidance v04 section 9.1.3 PKPM1 Peak power meter method.
2. The RF output of EUT was connected to the power meter by RF cable and attenuator. The path loss was compensated to the results for each measurement.
3. Set to the maximum power setting and enable the EUT transmit continuously.
4. Measure the conducted output power and record the results in the test report.

3.1.4 Test Setup

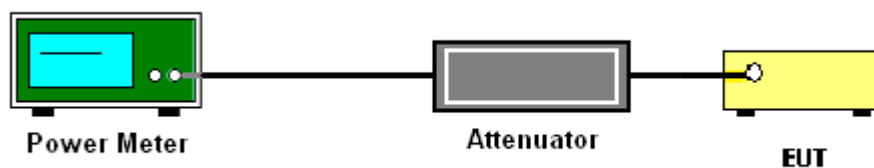

3.1.5 Test Result of Peak Output Power

Please refer to Appendix A.

3.1.6 Test Result of Average output Power (Reporting Only)

Please refer to Appendix A.



3.2 Radiated Band Edges and Spurious Emission Measurement

3.2.1 Limit of Radiated band edge and Spurious Emission Measurement

In any 100 kHz bandwidth outside the intentional radiator frequency band, all harmonics/spurious must be at least 20 dB below the highest emission level within the authorized band. If the output power of this device was measured by spectrum analyzer, the attenuation under this paragraph shall be 30 dB instead of 20 dB. In addition, radiated emissions which fall in the restricted bands must also comply with the limits as below.

| Frequency (MHz) | Field Strength (microvolts/meter) | Measurement Distance (meters) |
|-----------------|-----------------------------------|-------------------------------|
| 0.009 – 0.490 | 2400/F(kHz) | 300 |
| 0.490 – 1.705 | 24000/F(kHz) | 30 |
| 1.705 – 30.0 | 30 | 30 |
| 30 – 88 | 100 | 3 |
| 88 – 216 | 150 | 3 |
| 216 - 960 | 200 | 3 |
| Above 960 | 500 | 3 |

3.2.2 Measuring Instruments

The measuring equipment is listed in the section 4 of this test report.



3.2.3 Test Procedures

1. The testing follows FCC KDB Publication No. 558074 D01 DTS Meas. Guidance v04.
2. The EUT was arranged to its worst case and then tune the antenna tower (from 1 m to 4 m) and turntable (from 0 degree to 360 degrees) to find the maximum reading. A pre-amp and a high pass filter are used for the test in order to get better signal level.
3. The EUT was placed on a turntable with 0.8 meter for frequency below 1GHz and 1.5 meter for frequency above 1GHz respectively above ground.
4. The EUT was set 3 meters from the interference receiving antenna, which was mounted on the top of a variable height antenna tower.
5. Corrected Reading: Antenna Factor + Cable Loss + Read Level - Preamp Factor = Level
6. For testing below 1GHz, if the emission level of the EUT in peak mode was 3 dB lower than the limit specified, then peak values of EUT will be reported, otherwise, the emissions will be repeated one by one using the CISPR quasi-peak method and reported.
7. For testing above 1GHz, the emission level of the EUT in peak mode was 20dB lower than average limit (that means the emission level in average mode also complies with the limit in average mode), then peak values of EUT will be reported, otherwise, the emissions will be measured in average mode again and reported.
8. Use the following spectrum analyzer settings:
 - (1) Span shall wide enough to fully capture the emission being measured;
 - (2) Set RBW=100 kHz for $f < 1$ GHz; VBW \geq RBW; Sweep = auto; Detector function = peak; Trace = max hold;
 - (3) Set RBW = 1 MHz, VBW= 3MHz for $f \geq 1$ GHz for peak measurement.
For average measurement:
 - VBW = 10 Hz, when duty cycle is no less than 98 percent.
 - VBW $\geq 1/T$, when duty cycle is less than 98 percent where T is the minimum transmission duration over which the transmitter is on and is transmitting at its maximum power control level for the tested mode of operation.

3.2.4 Test Setup

For radiated emissions below 30MHz

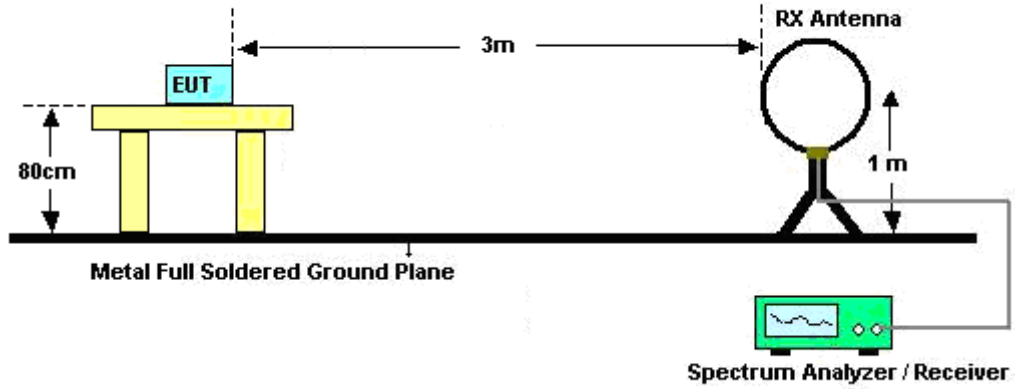

For radiated emissions from 30MHz to 1GHz

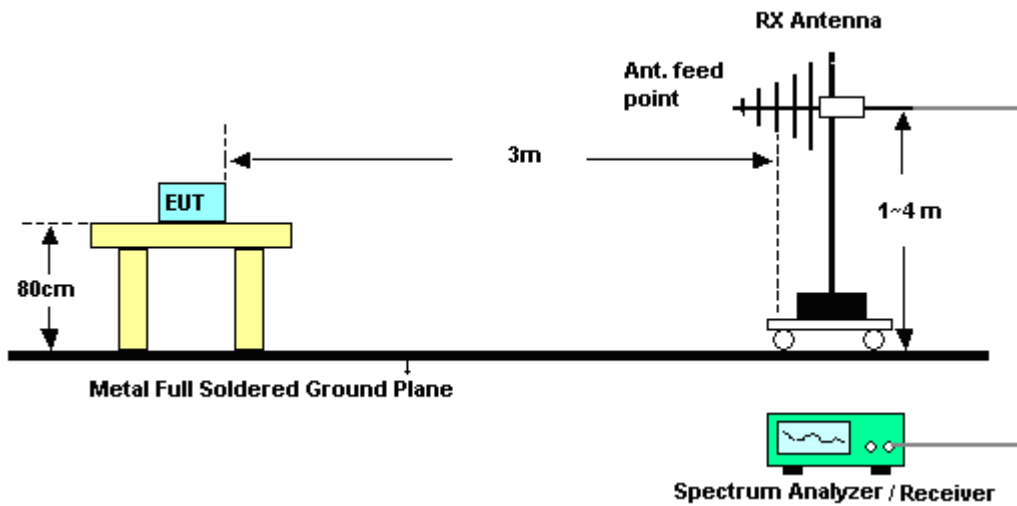

For radiated emissions above 1GHz

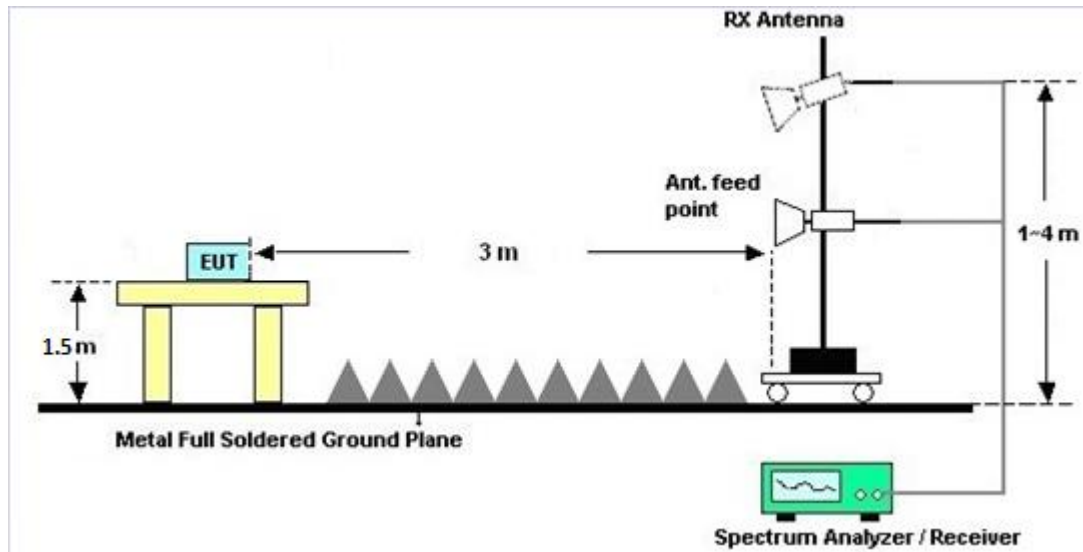

3.2.5 Test Results of Radiated Spurious Emissions (9kHz ~ 30MHz)

The low frequency, which started from 9 kHz to 30MHz, was pre-scanned and the result which was 20dB lower than the limit line was not reported.

There is a comparison data of both open-field test site and semi-Anechoic chamber, and the result came out very similar.

3.2.6 Test Result of Radiated Spurious at Band Edges

Please refer to Appendix B and C.

3.2.7 Duty Cycle

Please refer to Appendix D.

3.2.8 Test Result of Radiated Spurious Emission (30MHz ~ 10th Harmonic)

Please refer to Appendix B. and C.



3.3 Antenna Requirements

3.3.1 Standard Applicable

If directional gain of transmitting antennas is greater than 6dBi, the power shall be reduced by the same level in dB comparing to gain minus 6dBi. The use of a permanently attached antenna or of an antenna that uses a unique coupling to the intentional radiator shall be considered sufficient to comply with the rule.

3.3.2 Antenna Anti-Replacement Construction

An embedded-in antenna design is used.

3.3.3 Antenna Gain

The antenna peak gain of EUT is less than 6 dBi. Therefore, it is not necessary to reduce maximum peak output power limit.



4 List of Measuring Equipment

| Instrument | Manufacturer | Model No. | Serial No. | Characteristics | Calibration Date | Test Date | Due Date | Remark |
|----------------------|-------------------|---------------------------------|-----------------|-------------------------------------|------------------|---------------------------------|---------------|--------------------------|
| Power Meter | Agilent | E4416A | GB412923 44 | N/A | Dec. 26, 2016 | Oct. 13, 2017~ Nov. 01, 2017 | Dec. 25, 2017 | Conducted (TH05-HY) |
| Power Sensor | Agilent | E9327A | US404415 48 | 50MHz~18GHz | Dec. 26, 2016 | Oct. 13, 2017~ Nov. 01, 2017 | Dec. 25, 2017 | Conducted (TH05-HY) |
| Spectrum Analyzer | Rohde & Schwarz | FSP30 | 101067 | 9kHz ~ 30GHz | Nov. 17, 2016 | Oct. 13, 2017~ Nov. 01, 2017 | Nov. 16, 2017 | Conducted (TH05-HY) |
| Hygrometer | TECEPEL | DTM-303B | TP157151 | N/A | Mar. 20, 2017 | Oct. 13, 2017~ Nov. 01, 2017 | Mar. 19, 2018 | Conducted (TH05-HY) |
| RF Cable | HUBER + SUHNER | SUCOFLEX 104 | MY842095 21 | 1GHz~26GHz | Dec. 02, 2016 | Oct. 13, 2017~ Nov. 01, 2017 | Dec. 01, 2017 | Conducted (TH05-HY) |
| Loop Antenna | Rohde & Schwarz | HFH2-Z2 | 100315 | 9 kHz~30 MHz | May 15, 2017 | Oct. 19, 2017~ Oct. 20, 2017 | May 14, 2019 | Radiation (03CH13-HY) |
| Bilog Antenna | TESEQ | CBL 6111D&00800 N1D01N-06 | 40103&04 | 30MHz to 1GHz | Jan. 07, 2017 | Oct. 19, 2017~ Oct. 20, 2017 | Jan. 06, 2018 | Radiation (03CH13-HY) |
| Horn Antenna | SCHWARZBECK | BBHA 9120 D | 9120D-124 1 | 1GHz ~ 18GHz | May 02, 2017 | Oct. 19, 2017~ Oct. 20, 2017 | May 01, 2018 | Radiation (03CH13-HY) |
| SHF-EHF Horn Antenna | SCHWARZBECK | BBHA 9170 | BBHA9170 584 | 18GHz- 40GHz | Nov. 08, 2016 | Oct. 19, 2017~ Oct. 20, 2017 | Nov. 07, 2017 | Radiation (03CH13-HY) |
| Spectrum Analyzer | Keysight | N9010A | MY553705 26 | N/A | Mar. 15, 2017 | Oct. 19, 2017~ Oct. 20, 2017 | Mar. 14, 2018 | Radiation (03CH13-HY) |
| EMI Test Receiver | Agilent | N9038A(MXE) | MY532900 53 | 20Hz to 26.5GHz | Jan. 12, 2017 | Oct. 19, 2017~ Oct. 20, 2017 | Jan. 11, 2018 | Radiation (03CH13-HY) |
| Amplifier | Sonoma-Instrument | 310 N | 187282 | 9KHz~1GHz | Dec. 21, 2016 | Oct. 19, 2017~ Oct. 20, 2017 | Dec. 20, 2017 | Radiation (03CH13-HY) |
| Preamplifier | MITEQ | AMF-7D-0010 1800-30-10P | 1590074 | 1GHz~18GHz | May 22, 2017 | Oct. 19, 2017~ Oct. 20, 2017 | May 21, 2018 | Radiation (03CH13-HY) |
| Preamplifier | Keysight | 83017A | MY532701 47 | 1GHz~26.5GHz | Jan. 09, 2017 | Oct. 19, 2017~ Oct. 20, 2017 | Jan. 08, 2018 | Radiation (03CH13-HY) |
| Amplifier | MITEQ | TTA1840-35- HG | 1871923 | 18GHz~40GHz, VSWR : 2.5:1 max | Jul. 18, 2017 | Oct. 19, 2017~ Oct. 20, 2017 | Jul. 17, 2018 | Radiation (03CH13-HY) |



| Instrument | Manufacturer | Model No. | Serial No. | Characteristics | Calibration Date | Test Date | Due Date | Remark |
|---------------|-------------------|-------------------------------------|------------------------------------|----------------------------------|------------------|---------------------------------|---------------|--------------------------|
| Hygrometer | TECEP | DTM-303B | TP140320 | N/A | Nov. 14, 2016 | Oct. 19, 2017~ Oct. 20, 2017 | Nov. 13, 2017 | Radiation (03CH13-HY) |
| RF Cable | HUBER + SUHNER | SUCOFLEX 104 | MY335041/4 MY9840/4 MY9838/4 | 26GHz~40GHz | Mar. 27, 2017 | Oct. 19, 2017~ Oct. 20, 2017 | Mar. 26, 2018 | Radiation (03CH13-HY) |
| RF Cable | HUBER + SUHNER | SUCOFLEX 104 | MY335041/4 MY9840/4 MY9838/4 | 30MHz~1GHz | Jan. 27, 2017 | Oct. 19, 2017~ Oct. 20, 2017 | Jan. 26, 2018 | Radiation (03CH13-HY) |
| RF Cable | HUBER + SUHNER | SUCOFLEX 104 | MY335041/4 MY9840/4 MY9838/4 | 1GHz~26GHz | Jan. 27, 2017 | Oct. 19, 2017~ Oct. 20, 2017 | Jan. 26, 2018 | Radiation (03CH13-HY) |
| Controller | EMEC | EM1000 | N/A | Control Turn table & Ant Mast | N/A | Oct. 19, 2017~ Oct. 20, 2017 | N/A | Radiation (03CH13-HY) |
| Antenna Mast | EMEC | AM-BS-450 0-B | N/A | 1m~4m | N/A | Oct. 19, 2017~ Oct. 20, 2017 | N/A | Radiation (03CH13-HY) |
| Turn Table | EMEC | TT2000 | N/A | 0~360 Degree | N/A | Oct. 19, 2017~ Oct. 20, 2017 | N/A | Radiation (03CH13-HY) |
| Test Software | Audix | E3 | 6.2009-8-24 | N/A | N/A | Oct. 19, 2017~ Oct. 20, 2017 | N/A | Radiation (03CH13-HY) |
| Filter | Wainwright | WLKS1200- 12SS | SN2 | 1.2G Low Pass | Sep. 18, 2017 | Oct. 19, 2017~ Oct. 20, 2017 | Sep. 17, 2018 | Radiation (03CH13-HY) |
| Filter | Wainwright | WHKX12-27 00-3000-18 000-60SS | SN2 | 3G High Pass | Sep. 18, 2017 | Oct. 19, 2017~ Oct. 20, 2017 | Sep. 17, 2018 | Radiation (03CH13-HY) |



5 Uncertainty of Evaluation

Uncertainty of Radiated Emission Measurement (30 MHz ~ 1000 MHz)

| | |
|---|------|
| Measuring Uncertainty for a Level of Confidence of 95% ($U = 2Uc(y)$) | 4.90 |
|---|------|

Uncertainty of Radiated Emission Measurement (1000 MHz ~ 18000 MHz)

| | |
|---|------|
| Measuring Uncertainty for a Level of Confidence of 95% ($U = 2Uc(y)$) | 5.40 |
|---|------|

Uncertainty of Radiated Emission Measurement (18000 MHz ~ 40000 MHz)

| | |
|---|------|
| Measuring Uncertainty for a Level of Confidence of 95% ($U = 2Uc(y)$) | 4.30 |
|---|------|

Appendix A. Test Result of Conducted Test Items

| | | | | |
|----------------|-----------------------|--------------------|-------|----|
| Test Engineer: | Shiming Liu/Reece Lin | Temperature: | 21~25 | °C |
| Test Date: | 2017/10/13~2017/11/01 | Relative Humidity: | 51~54 | % |

TEST RESULTS DATA
Peak Power Table

| 2.4GHz Band | | | | | | | | | | |
|-------------|-----------|-----------------|-----|-------------|----------------------------|-----------------------------|----------|------------------|------------------------|------------|
| Mod. | Data Rate | N _{TX} | CH. | Freq. (MHz) | Peak Conducted Power (dBm) | Conducted Power Limit (dBm) | DG (dBi) | EIRP Power (dBm) | EIRP Power Limit (dBm) | Pass /Fail |
| 11b | 1Mbps | 1 | 1 | 2412 | 19.06 | 30.00 | -1.50 | 17.56 | 36.00 | Pass |
| 11b | 1Mbps | 1 | 6 | 2437 | 18.82 | 30.00 | -1.50 | 17.32 | 36.00 | Pass |
| 11b | 1Mbps | 1 | 11 | 2462 | 18.50 | 30.00 | -1.50 | 17.00 | 36.00 | Pass |
| 11g | 6Mbps | 1 | 1 | 2412 | 18.02 | 30.00 | -1.50 | 16.52 | 36.00 | Pass |
| 11g | 6Mbps | 1 | 6 | 2437 | 17.74 | 30.00 | -1.50 | 16.24 | 36.00 | Pass |
| 11g | 6Mbps | 1 | 11 | 2462 | 18.00 | 30.00 | -1.50 | 16.50 | 36.00 | Pass |
| HT20 | MCS0 | 1 | 1 | 2412 | 17.34 | 30.00 | -1.50 | 15.84 | 36.00 | Pass |
| HT20 | MCS0 | 1 | 6 | 2437 | 17.22 | 30.00 | -1.50 | 15.72 | 36.00 | Pass |
| HT20 | MCS0 | 1 | 11 | 2462 | 17.55 | 30.00 | -1.50 | 16.05 | 36.00 | Pass |
| VHT20 | MCS0 | 1 | 1 | 2412 | 17.35 | 30.00 | -1.50 | 15.85 | 36.00 | Pass |
| VHT20 | MCS0 | 1 | 6 | 2437 | 17.25 | 30.00 | -1.50 | 15.75 | 36.00 | Pass |
| VHT20 | MCS0 | 1 | 11 | 2462 | 17.57 | 30.00 | -1.50 | 16.07 | 36.00 | Pass |

TEST RESULTS DATA
Average Power Table
(Reporting Only)

| 2.4GHz Band | | | | | | |
|-------------|-----------|-----------------|-----|-------------|------------------|-------------------------------|
| Mod. | Data Rate | N _{TX} | CH. | Freq. (MHz) | Duty Factor (dB) | Average Conducted Power (dBm) |
| 11b | 1Mbps | 1 | 1 | 2412 | 0.00 | 16.25 |
| 11b | 1Mbps | 1 | 6 | 2437 | 0.00 | 16.02 |
| 11b | 1Mbps | 1 | 11 | 2462 | 0.00 | 16.00 |
| 11g | 6Mbps | 1 | 1 | 2412 | 0.23 | 13.38 |
| 11g | 6Mbps | 1 | 6 | 2437 | 0.23 | 13.23 |
| 11g | 6Mbps | 1 | 11 | 2462 | 0.23 | 13.38 |
| HT20 | MCS0 | 1 | 1 | 2412 | 0.25 | 12.73 |
| HT20 | MCS0 | 1 | 6 | 2437 | 0.25 | 12.47 |
| HT20 | MCS0 | 1 | 11 | 2462 | 0.25 | 12.84 |
| VHT20 | MCS0 | 1 | 1 | 2412 | 0.25 | 12.74 |
| VHT20 | MCS0 | 1 | 6 | 2437 | 0.25 | 12.48 |
| VHT20 | MCS0 | 1 | 11 | 2462 | 0.25 | 12.85 |



Appendix B. Radiated Spurious Emission

| | | | |
|-----------------|--------------------------|---------------------|-------------|
| Test Engineer : | Bill Chang and Wilson Wu | Temperature : | 25.0~25.1°C |
| | | Relative Humidity : | 56~59% |

2.4GHz 2400~2483.5MHz

WIFI 802.11b (Band Edge @ 3m)

| WIFI Ant. 1 | Note | Frequency (MHz) | Level (dBμV/m) | Over Limit (dB) | Limit Line (dBμV/m) | Read Level (dBμV) | Antenna Factor (dB/m) | Cable Loss (dB) | Preamp Factor (dB) | Ant Pos (cm) | Table Pos (deg) | Peak Avg. (P/A) | Pol. (H/V) |
|-----------------------------|---|-------------------|------------------|-------------------|-----------------------|---------------------|-------------------------|-------------------|----------------------|----------------|-------------------|-------------------|--------------|
| 802.11b CH 11 2462MHz | * | 2462 | 102.46 | - | - | 91.5 | 27.1 | 4.9 | 30.97 | 123 | 227 | P | H |
| | * | 2462 | 99.39 | - | - | 88.43 | 27.1 | 4.9 | 30.97 | 123 | 227 | A | H |
| | | 2484.8 | 53.69 | -20.31 | 74 | 42.65 | 27.15 | 4.93 | 30.97 | 123 | 227 | P | H |
| | | 2483.52 | 44.91 | -9.09 | 54 | 33.87 | 27.15 | 4.93 | 30.97 | 123 | 227 | A | H |
| | | | | | | | | | | | | | H |
| | | | | | | | | | | | | | H |
| | * | 2462 | 102.46 | - | - | 91.5 | 27.1 | 4.9 | 30.97 | 133 | 103 | P | V |
| | * | 2462 | 99.34 | - | - | 88.38 | 27.1 | 4.9 | 30.97 | 133 | 103 | A | V |
| | | 2483.52 | 52.57 | -21.43 | 74 | 41.53 | 27.15 | 4.93 | 30.97 | 133 | 103 | P | V |
| | | 2483.52 | 44.81 | -9.19 | 54 | 33.77 | 27.15 | 4.93 | 30.97 | 133 | 103 | A | V |
| | | | | | | | | | | | | | V |
| | | | | | | | | | | | | | V |
| Remark | 1. No other spurious found. 2. All results are PASS against Peak and Average limit line. | | | | | | | | | | | | |



**2.4GHz 2400~2483.5MHz
WIFI 802.11b (Harmonic @ 3m)**

| WIFI | Note | Frequency | Level | Over | Limit | Read | Antenna | Cable | Preamp | Ant | Table | Peak | Pol. | |
|-----------------------------|---|-----------|------------|--------|------------|----------|----------|--------|--------|--------|---------|---------|---------|---|
| Ant. | | | | Limit | Line | Level | Factor | Loss | Factor | Pos | Pos | Avg. | | |
| 1 | | (MHz) | (dBμV/m) | (dB) | (dBμV/m) | (dBμV) | (dB/m) | (dB) | (dB) | (cm) | (deg) | (P/A) | (H/V) | |
| 802.11b CH 11 2462MHz | | 4924 | 40.32 | -33.68 | 74 | 57.7 | 31.7 | 7.52 | 57.1 | 100 | 0 | P | H | |
| | | 7386 | 44.2 | -29.8 | 74 | 55.65 | 36.31 | 9.18 | 57.38 | 100 | 0 | P | H | |
| | | | | | | | | | | | | | H | |
| | | | | | | | | | | | | | H | |
| | | 4924 | 42.59 | -31.41 | 74 | 59.97 | 31.7 | 7.52 | 57.1 | 100 | 0 | P | V | |
| | | 7386 | 44.63 | -29.37 | 74 | 56.08 | 36.31 | 9.18 | 57.38 | 100 | 0 | P | V | |
| | | | | | | | | | | | | | | V |
| | | | | | | | | | | | | | | V |
| Remark | 1. No other spurious found. 2. All results are PASS against Peak and Average limit line. | | | | | | | | | | | | | |



**2.4GHz 2400~2483.5MHz
WIFI 802.11ac VHT20 (Band Edge @ 3m)**

| WIFI | Note | Frequency | Level | Over | Limit | Read | Antenna | Cable | Preamp | Ant | Table | Peak | Pol. |
|---------------------------------------|---|-----------|------------|--------|------------|----------|----------|--------|--------|--------|---------|---------|---------|
| Ant. | | | | Limit | Line | Level | Factor | Loss | Factor | Pos | Pos | Avg. | |
| 1 | | (MHz) | (dBμV/m) | (dB) | (dBμV/m) | (dBμV) | (dB/m) | (dB) | (dB) | (cm) | (deg) | (P/A) | (H/V) |
| 802.11ac VHT20 CH 11 2462MHz | * | 2462 | 102.06 | - | - | 91.1 | 27.1 | 4.9 | 30.97 | 157 | 186 | P | H |
| | * | 2462 | 93.43 | - | - | 82.47 | 27.1 | 4.9 | 30.97 | 157 | 186 | A | H |
| | | 2483.52 | 56.99 | -17.01 | 74 | 45.95 | 27.15 | 4.93 | 30.97 | 157 | 186 | P | H |
| | | 2483.52 | 47.32 | -6.68 | 54 | 36.28 | 27.15 | 4.93 | 30.97 | 157 | 186 | A | H |
| | | | | | | | | | | | | | H |
| | | | | | | | | | | | | | H |
| | * | 2462 | 103.16 | - | - | 92.2 | 27.1 | 4.9 | 30.97 | 164 | 126 | P | V |
| | * | 2462 | 94.63 | - | - | 83.67 | 27.1 | 4.9 | 30.97 | 164 | 126 | A | V |
| | | 2483.68 | 58.21 | -15.79 | 74 | 47.17 | 27.15 | 4.93 | 30.97 | 164 | 126 | P | V |
| | | 2483.6 | 48.99 | -5.01 | 54 | 37.95 | 27.15 | 4.93 | 30.97 | 164 | 126 | A | V |
| | | | | | | | | | | | | V | |
| | | | | | | | | | | | | V | |
| Remark | 1. No other spurious found. 2. All results are PASS against Peak and Average limit line. | | | | | | | | | | | | |



**2.4GHz 2400~2483.5MHz
WIFI 802.11ac VHT20 (Harmonic @ 3m)**

| WIFI | Note | Frequency | Level | Over | Limit | Read | Antenna | Cable | Preamp | Ant | Table | Peak | Pol. | |
|---------------------------------------|---|-----------|------------|--------|------------|----------|----------|--------|--------|--------|---------|---------|---------|---|
| Ant. | | | | Limit | Line | Level | Factor | Loss | Factor | Pos | Pos | Avg. | | |
| 1 | | (MHz) | (dBµV/m) | (dB) | (dBµV/m) | (dBµV) | (dB/m) | (dB) | (dB) | (cm) | (deg) | (P/A) | (H/V) | |
| 802.11ac VHT20 CH 11 2462MHz | | 4924 | 39.11 | -34.89 | 74 | 56.49 | 31.7 | 7.52 | 57.1 | 100 | 0 | P | H | |
| | | 7386 | 43.5 | -30.5 | 74 | 54.95 | 36.31 | 9.18 | 57.38 | 100 | 0 | P | H | |
| | | | | | | | | | | | | | H | |
| | | | | | | | | | | | | | H | |
| | | 4924 | 39.09 | -34.91 | 74 | 56.47 | 31.7 | 7.52 | 57.1 | 100 | 0 | P | V | |
| | | 7386 | 43.59 | -30.41 | 74 | 55.04 | 36.31 | 9.18 | 57.38 | 100 | 0 | P | V | |
| | | | | | | | | | | | | | | V |
| | | | | | | | | | | | | | | V |
| Remark | 1. No other spurious found. 2. All results are PASS against Peak and Average limit line. | | | | | | | | | | | | | |



Emission below 1GHz
2.4GHz WIFI 802.11b (LF)

Table with 14 columns: WIFI Ant. 1, Note, Frequency (MHz), Level (dBµV/m), Over Limit (dB), Limit Line (dBµV/m), Read Level (dBµV), Antenna Factor (dB/m), Cable Loss (dB), Preamp Factor (dB), Ant Pos (cm), Table Pos (deg), Peak Avg. (P/A), Pol. (H/V). Rows include test data for 2.4GHz 802.11b LF and a Remark section.



Emission below 1GHz

2.4GHz WIFI 802.11ac VHT20 (LF)

| WIFI Ant. 1 | Note | Frequency (MHz) | Level (dBμV/m) | Over Limit (dB) | Limit Line (dBμV/m) | Read Level (dBμV) | Antenna Factor (dB/m) | Cable Loss (dB) | Preamp Factor (dB) | Ant Pos (cm) | Table Pos (deg) | Peak Avg. (P/A) | Pol. (H/V) | |
|-----------------------------------|--|-------------------|------------------|-------------------|-----------------------|-------------------|-------------------------|-------------------|----------------------|----------------|-------------------|-----------------|------------|---|
| 2.4GHz 802.11ac VHT20 LF | | 59.97 | 19.12 | -20.88 | 40 | 42.05 | 8.56 | 0.84 | 32.31 | | | P | H | |
| | | 138 | 30.74 | -12.76 | 43.5 | 47.49 | 14.3 | 1.19 | 32.28 | 100 | 0 | P | H | |
| | | 221.43 | 23.5 | -22.5 | 46 | 42.07 | 12.07 | 1.53 | 32.24 | | | P | H | |
| | | 432.3 | 24.63 | -21.37 | 46 | 35.25 | 19.44 | 2.03 | 32.17 | | | P | H | |
| | | 652.1 | 25.22 | -20.78 | 46 | 31.37 | 23.41 | 2.51 | 32.19 | | | P | H | |
| | | 936.3 | 30.36 | -15.64 | 46 | 31.25 | 27.14 | 3.02 | 31.18 | | | P | H | |
| | | | | | | | | | | | | | | H |
| | | | | | | | | | | | | | | H |
| | | | | | | | | | | | | | | H |
| | | | | | | | | | | | | | | H |
| | | | | | | | | | | | | | | H |
| | | | | | | | | | | | | | | H |
| | | | 32.16 | 36.18 | -3.82 | 40 | 46.98 | 20.97 | 0.59 | 32.34 | 100 | 0 | P | V |
| | | | 77.25 | 26.66 | -13.34 | 40 | 47.61 | 10.31 | 0.95 | 32.3 | | | P | V |
| | | | 119.91 | 23.59 | -19.91 | 43.5 | 41.22 | 13.51 | 1.09 | 32.29 | | | P | V |
| | | | 517 | 21.48 | -24.52 | 46 | 30.65 | 20.7 | 2.24 | 32.2 | | | P | V |
| | | | 722.1 | 26.88 | -19.12 | 46 | 31.82 | 24.43 | 2.66 | 32.13 | | | P | V |
| | | | 928.6 | 30.07 | -15.93 | 46 | 31.28 | 26.89 | 3.02 | 31.25 | | | P | V |
| | | | | | | | | | | | | | V | |
| | | | | | | | | | | | | | V | |
| | | | | | | | | | | | | | V | |
| | | | | | | | | | | | | | V | |
| | | | | | | | | | | | | | V | |
| | | | | | | | | | | | | | V | |
| Remark | 1. No other spurious found. 2. All results are PASS against limit line. | | | | | | | | | | | | | |



Note symbol

| | |
|-----|--|
| * | Fundamental Frequency which can be ignored. However, the level of any unwanted emissions shall not exceed the level of the fundamental frequency. |
| ! | Test result is over limit line. |
| P/A | Peak or Average |
| H/V | Horizontal or Vertical |



A calculation example for radiated spurious emission is shown as below:

| WIFI Ant. 1 | Note | Frequency (MHz) | Level (dBμV/m) | Over Limit (dB) | Limit Line (dBμV/m) | Read Level (dBμV) | Antenna Factor (dB/m) | Cable Loss (dB) | Preamp Factor (dB) | Ant Pos (cm) | Table Pos (deg) | Peak Avg. (P/A) | Pol. (H/V) |
|-----------------------|------|-------------------|------------------|-------------------|-----------------------|---------------------|-------------------------|-------------------|----------------------|----------------|-------------------|-------------------|--------------|
| 802.11b CH 01 2412MHz | | 2390 | 55.45 | -18.55 | 74 | 54.51 | 32.22 | 4.58 | 35.86 | 103 | 308 | P | H |
| | | 2390 | 43.54 | -10.46 | 54 | 42.6 | 32.22 | 4.58 | 35.86 | 103 | 308 | A | H |

- 1. Level(dBμV/m) = Antenna Factor(dB/m) + Cable Loss(dB) + Read Level(dBμV) - Preamp Factor(dB)
- 2. Over Limit(dB) = Level(dBμV/m) – Limit Line(dBμV/m)

For Peak Limit @ 2390MHz:

- 1. Level(dBμV/m) = Antenna Factor(dB/m) + Cable Loss(dB) + Read Level(dBμV) - Preamp Factor(dB) = 32.22(dB/m) + 4.58(dB) + 54.51(dBμV) – 35.86 (dB) = 55.45 (dBμV/m)
- 2. Over Limit(dB) = Level(dBμV/m) – Limit Line(dBμV/m) = 55.45(dBμV/m) – 74(dBμV/m) = -18.55(dB)

For Average Limit @ 2390MHz:

- 1. Level(dBμV/m) = Antenna Factor(dB/m) + Cable Loss(dB) + Read Level(dBμV) - Preamp Factor(dB) = 32.22(dB/m) + 4.58(dB) + 42.6(dBμV) – 35.86 (dB) = 43.54 (dBμV/m)
- 2. Over Limit(dB) = Level(dBμV/m) – Limit Line(dBμV/m) = 43.54(dBμV/m) – 54(dBμV/m) = -10.46(dB)

Both peak and average measured complies with the limit line, so test result is “PASS”.



Appendix C. Radiated Spurious Emission Plots

| | | | |
|-----------------|--------------------------|---------------------|-------------|
| Test Engineer : | Bill Chang and Wilson Wu | Temperature : | 25.0~25.1°C |
| | | Relative Humidity : | 56~59% |

Note symbol

| | |
|----|-----------------------|
| -L | Low channel location |
| -R | High channel location |



2.4GHz 2400~2483.5MHz
WIFI 802.11b (Band Edge @ 3m)

| WIFI | 2.4GHz 2400~2483.5MHz Band Edge @ 3m | |
|-------------|--|---|
| ANT | 802.11b CH11 2462MHz | |
| 1 | Horizontal | Fundamental |
| Peak | <p>Site : 03CH13-HY Condition : PEAK BE 74 3m HORN 9120D 1241 HORIZONTAL</p> | <p>Site : 03CH13-HY Condition : PEAK 74 3m HORN 9120D 1241 HORIZONTAL</p> |
| Avg. | <p>Site : 03CH13-HY Condition : AVG BE 54 3m HORN 9120D 1241 HORIZONTAL</p> | <p>Site : 03CH13-HY Condition : AVG 54 3m HORN 9120D 1241 HORIZONTAL</p> |



| WIFI | 2.4GHz 2400~2483.5MHz Band Edge @ 3m | |
|------|--|---|
| ANT | 802.11b CH11 2462MHz | |
| 1 | Vertical | Fundamental |
| Peak | <p>Site : 03CH13-HY Condition : PEAK_BE 74 3m HORN 9120D 1241 VERTICAL</p> | <p>Site : 03CH13-HY Condition : PEAK_74 3m HORN 9120D 1241 VERTICAL</p> |
| Avg. | <p>Site : 03CH13-HY Condition : AVG_BE 54 3m HORN 9120D 1241 VERTICAL</p> | <p>Site : 03CH13-HY Condition : AVG_54 3m HORN 9120D 1241 VERTICAL</p> |

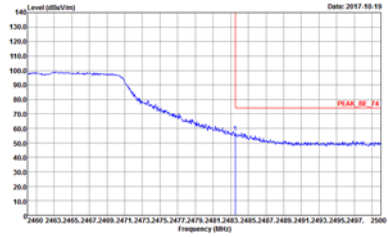
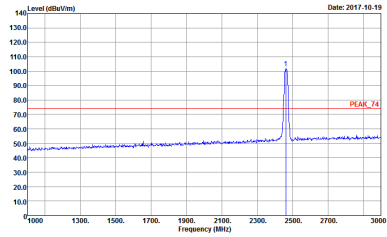
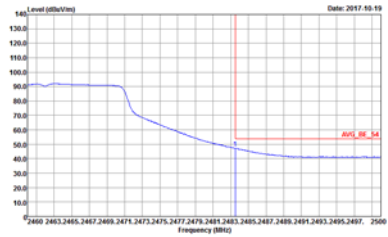
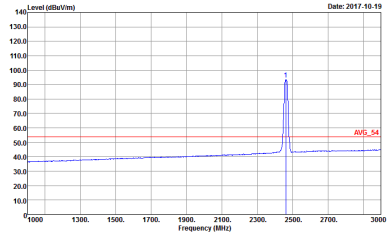

2.4GHz 2400~2483.5MHz
WIFI 802.11ac VHT20 (Band Edge @ 3m)

| WIFI | 2.4GHz 2400~2483.5MHz Band Edge @ 3m | |
|------|--|--|
| ANT | 802.11ac VH20 CH11 2462MHz | |
| 1 | Horizontal | Fundamental |
| Peak |  <p>Site : 03CH13-HY Condition : PEAK_BE_74 3m HORN_9120D_1241 HORIZONTAL</p> |  <p>Site : 03CH13-HY Condition : PEAK_74 3m HORN_9120D_1241 HORIZONTAL</p> |
| Avg. |  <p>Site : 03CH13-HY Condition : AVG_BE_54 3m HORN_9120D_1241 HORIZONTAL</p> |  <p>Site : 03CH13-HY Condition : AVG_54 3m HORN_9120D_1241 HORIZONTAL</p> |



| WIFI | 2.4GHz 2400~2483.5MHz Band Edge @ 3m | |
|------|--|---|
| ANT | 802.11ac VH20 CH11 2462MHz | |
| 1 | Vertical | Fundamental |
| Peak | <p>Site : 03CH13-HY Condition : PEAK_BE_74 3m HORN_9120D_1241 VERTICAL</p> | <p>Site : 03CH13-HY Condition : PEAK_74 3m HORN_9120D_1241 VERTICAL</p> |
| Avg. | <p>Site : 03CH13-HY Condition : AV6_BE_54 3m HORN_9120D_1241 VERTICAL</p> | <p>Site : 03CH13-HY Condition : AV6_54 3m HORN_9120D_1241 VERTICAL</p> |



2.4GHz 2400~2483.5MHz
WIFI 802.11b (Harmonic @ 3m)

| WIFI | 2.4GHz 2400~2483.5MHz Harmonic @ 3m | |
|--------------|---|---|
| ANT | 802.11b CH11 2462MHz | |
| 1 | Horizontal | Vertical |
| Peak Avg. | <p>Site : 03CH13-14Y Condition : PEAK 74 3m SHF HORN 584 HORIZONTAL</p> | <p>Site : 03CH13-14Y Condition : PEAK 74 3m SHF HORN 584 VERTICAL</p> |



2.4GHz 2400~2483.5MHz
WIFI 802.11ac VHT20 (Harmonic @ 3m)

| WIFI | 2.4GHz 2400~2483.5MHz Harmonic @ 3m | |
|--------------|---|---|
| ANT | 802.11ac VHT20 CH11 2462MHz | |
| 1 | Horizontal | Vertical |
| Peak Avg. | <p>Horizontal spectrum plot showing Level (dBuV/m) vs Frequency (MHz). The plot displays two distinct peaks labeled '1' and '2' at approximately 5.2 GHz and 5.4 GHz respectively. The y-axis ranges from 0 to 140 dBuV/m, and the x-axis ranges from 1000 to 25000 MHz. Two horizontal red lines indicate limits: 'PEAK 74' at approximately 74 dBuV/m and 'AVG 54' at approximately 54 dBuV/m. The plot is dated 2017-10-19. Site: 03CH13-14Y, Condition: PEAK 74 3m SHF HORN 584 HORIZONTAL.</p> | <p>Vertical spectrum plot showing Level (dBuV/m) vs Frequency (MHz). The plot displays two distinct peaks labeled '1' and '2' at approximately 5.2 GHz and 5.4 GHz respectively. The y-axis ranges from 0 to 140 dBuV/m, and the x-axis ranges from 1000 to 25000 MHz. Two horizontal red lines indicate limits: 'PEAK 74' at approximately 74 dBuV/m and 'AVG 54' at approximately 54 dBuV/m. The plot is dated 2017-10-19. Site: 03CH13-14Y, Condition: PEAK 74 3m SHF HORN 584 VERTICAL.</p> |



Emission below 1GHz
2.4GHz WIFI 802.11b (LF)

| WIFI | 2.4GHz 2400~2483.5MHz | |
|--------------|--|--|
| ANT | 802.11b LF | |
| 1 | Horizontal | Vertical |
| QP / Peak | <p>Site : 03CH13-HY Condition : QP-3m B1LOG 40103 HORIZONTAL</p> | <p>Site : 03CH13-HY Condition : QP-3m B1LOG 40103 VERTICAL</p> |



Emission below 1GHz
2.4GHz WIFI 802.11ac VHT20 (LF)

| WIFI | 2.4GHz 2400~2483.5MHz | |
|--------------|--|--|
| ANT | 802.11ac VHT20 LF | |
| 1 | Horizontal | Vertical |
| QP / Peak | <p>Site : 03CH13-HY Condition : QP-3m B1LOG 40103 HORIZONTAL</p> | <p>Site : 03CH13-HY Condition : QP-3m B1LOG 40103 VERTICAL</p> |



Appendix D. Duty Cycle Plots

| Band | Duty Cycle(%) | T(us) | 1/T(kHz) | VBW Setting |
|----------------|---------------|-------|----------|-------------|
| 802.11b | 99.02 | - | - | 10Hz |
| 802.11ac VHT20 | 94.53 | 1900 | 0.53 | 1kHz |

802.11b

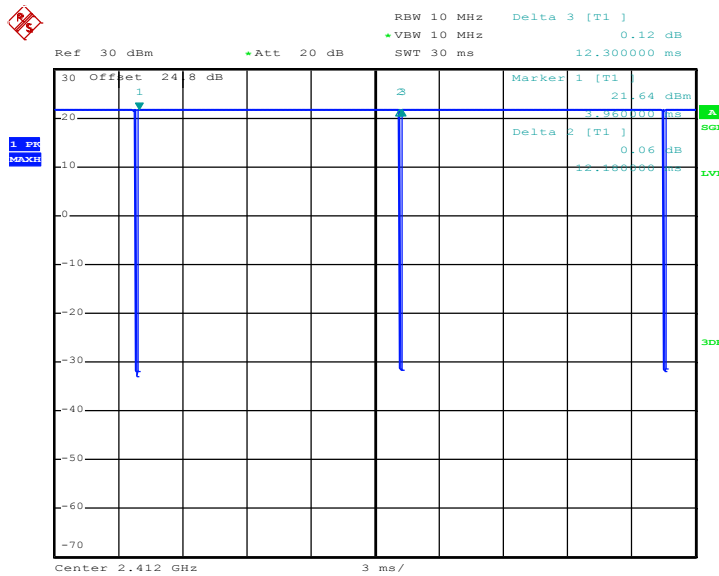

Date: 25.SEP.2017 09:48:49



802.11ac VHT20

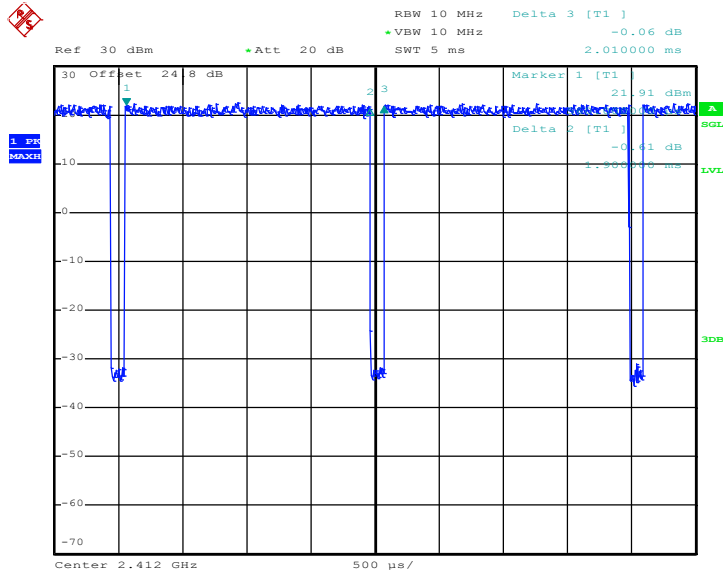

Date: 25.SEP.2017 09:51:16



Appendix E. Original Report

Please refer to Sporton report number FR762713-01C