



FCC RADIO TEST REPORT

FCC ID : PY7-67200Y
Equipment : GSM/WCDMA/LTE Phone+Bluetooth,
DTS/UNII a/b/g/n/ac and NFC
Brand Name : Sony
Applicant : Sony Mobile Communications Inc.
4-12-3 Higashi-Shinagawa, Shinagawa-ku,
Tokyo, 140-0002, Japan
Manufacturer : Sony Mobile Communications Inc.
4-12-3 Higashi-Shinagawa, Shinagawa-ku,
Tokyo, 140-0002, Japan
Standard : FCC Part 15 Subpart E §15.407

The product was received on Aug. 14, 2018 and testing was started from Sep. 10, 2018 and completed on Nov. 09, 2018. We, SPORTON INTERNATIONAL INC., would like to declare that the tested sample has been evaluated in accordance with the test procedures and has been in compliance with the applicable technical standards.

The report must not be used by the client to claim product certification, approval, or endorsement by TAF or any agency of government.

The test results in this variant report apply exclusively to the tested model / sample. Without written approval of SPORTON INTERNATIONAL INC. EMC & Wireless Communications Laboratory, the test report shall not be reproduced except in full.

Approved by: Joseph Lin

SPORTON INTERNATIONAL INC. EMC & Wireless Communications Laboratory

No. 52, Huaya 1st Rd., Guishan Dist., Taoyuan City, Taiwan (R.O.C.)



Table of Contents

History of this test report	3
Summary of Test Result	4
1 General Description	5
1.1 Product Feature of Equipment Under Test.....	5
1.2 Modification of EUT.....	5
1.3 Testing Location.....	6
1.4 Applicable Standards	6
2 Test Configuration of Equipment Under Test	7
2.1 Carrier Frequency and Channel	7
2.2 Test Mode	8
2.3 Connection Diagram of Test System.....	9
2.4 EUT Operation Test Setup	9
3 Test Result.....	10
3.1 Maximum Conducted Output Power Measurement	10
3.2 Unwanted Emissions Measurement	12
3.3 Automatically Discontinue Transmission	17
3.4 Antenna Requirements	18
4 List of Measuring Equipment	19
5 Uncertainty of Evaluation	21
Appendix A. Conducted Test Results	
Appendix B. Radiated Spurious Emission	
Appendix C. Radiated Spurious Emission Plots	
Appendix D. Duty Cycle Plots	



History of this test report

Report No.	Version	Description	Issued Date
FR881330-01E	01	Initial issue of report	Nov. 14, 2018
FR881330-01E	02	Revising test data.	Dec. 06, 2018



Summary of Test Result

Report Clause	Ref Std. Clause	Test Items	Result (PASS/FAIL)	Remark
-	15.403(i)	26dB Bandwidth	Not Required	-
-	2.1049	99% Occupied Bandwidth	Not Required	-
3.1	15.407(a)	Maximum Conducted Output Power	Pass	-
-	15.407(a)	Power Spectral Density	Not Required	-
3.2	15.407(b)	Unwanted Emissions	Pass	Under limit 5.17 dB at 5351.040 MHz
-	15.207	AC Conducted Emission	Not Required	-
3.3	15.407(c)	Automatically Discontinue Transmission	Pass	-
3.4	15.203 15.407(a)	Antenna Requirement	Pass	-
Remark: 1. Not required means after assessing, test items are not necessary to carry out. 2. This is a variant report. All the test cases were performed on original report which can be referred to Sporton Report Number FR881329-01E.				

Reviewed by: Wii Chang

Report Producer: Natasha Hsieh



1 General Description

1.1 Product Feature of Equipment Under Test

GSM/WCDMA/LTE, Bluetooth, DTS/UNII a/b/g/n/ac, FM Receiver, NFC, and GNSS.

Standards-related Product Specification	
Antenna Type	Coupling Antenna
Antenna Type / Gain	<5150 MHz ~ 5250 MHz> -3.30 dBi
	<5250 MHz ~ 5350 MHz> -2.80 dBi
	<5470 MHz ~ 5725 MHz> -2.40 dBi

EUT Information List			
HW Version	SW Version	S/N	Performed Test Item
A	1.27	CQ30013BMC	RF conducted measurement
		CQ300195MX	Radiated Spurious Emission

Accessory List	
AC Adapter	Model Name: UCH32
	S/N: 6218W30200215
Earphone	Model Name: MH410c
	S/N: N/A
USB Cable	Model Name: UCB24
	S/N: N/A

Note:

1. Above EUT list used are electrically identical per declared by manufacturer.
2. Above the accessories list are used to exercise the EUT during test, and the serial number of each type of accessories is listed in each section of this report. .
3. For other wireless features of this EUT, test report will be issued separately.

1.2 Modification of EUT

No modifications are made to the EUT during all test items.



1.3 Testing Location

Sporton Lab is accredited to ISO 17025 by Taiwan Accreditation Foundation (TAF code : 1190) and the FCC designation No. TW1190 and TW0007 under the FCC 2.948(e) by Mutual Recognition Agreement (MRA) in FCC Test.

Test Site	SPORTON INTERNATIONAL INC.
Test Site Location	No.52, Huaya 1st Rd., Guishan Dist., Taoyuan City, Taiwan (R.O.C.) TEL: +886-3-327-3456 FAX: +886-3-328-4978
Test Site No.	Sporton Site No.
	TH05-HY

Note: The test site complies with ANSI C63.4 2014 requirement.

Test Site	SPORTON INTERNATIONAL INC.
Test Site Location	No.58, Aly. 75, Ln. 564, Wenhua 3rd, Rd., Guishan Dist., Taoyuan City, Taiwan (R.O.C.) TEL: +886-3-327-0868 FAX: +886-3-327-0855
Test Site No.	Sporton Site No.
	03CH11-HY

Note: The test site complies with ANSI C63.4 2014 requirement.

1.4 Applicable Standards

According to the specifications of the manufacturer, the EUT must comply with the requirements of the following standards:

- ♦ FCC Part 15 Subpart E
- ♦ FCC KDB 789033 D02 General UNII Test Procedures New Rules v02r01.
- ♦ FCC KDB 414788 D01 Radiated Test Site v01r01.
- ♦ ANSI C63.10-2013

Remark:

1. All test items were verified and recorded according to the standards and without any deviation during the test.
2. This EUT has also been tested and complied with the requirements of FCC Part 15, Subpart B, recorded in a separate test report.



2 Test Configuration of Equipment Under Test

- a. The EUT has been associated with peripherals and configuration operated in a manner tended to maximize its emission characteristics in a typical application. Frequency range investigated: radiation emission (9 kHz to the 10th harmonic of the highest fundamental frequency or to 40 GHz, whichever is lower). For radiated measurement, pre-scanned in three orthogonal panels, X, Y, Z. The worst cases (X plane) were recorded in this report.

2.1 Carrier Frequency and Channel

Frequency Band	Channel	Freq. (MHz)	Channel	Freq. (MHz)
5150-5250 MHz Band 1 (U-NII-1)	36	5180	44	5220
	38*	5190	46*	5230
	40	5200	48	5240
	42 [#]	5210		

Frequency Band	Channel	Freq. (MHz)	Channel	Freq. (MHz)
5250-5350 MHz Band 2 (U-NII-2A)	52	5260	60	5300
	54*	5270	62*	5310
	56	5280	64	5320
	58 [#]	5290		

Frequency Band	Channel	Freq. (MHz)	Channel	Freq. (MHz)
5470-5725 MHz Band 3 (U-NII-2C)	100	5500	112	5560
	102*	5510	116	5580
	104	5520	132	5660
	106 [#]	5530	134*	5670
	108	5540	136	5680
	110*	5550	140	5700



Frequency Band	Channel	Freq. (MHz)	Channel	Freq. (MHz)
TDWR Channel	118*	5590	124	5620
	120	5600	126*	5630
	122 [#]	5610	128	5640

Frequency Band	Channel	Freq. (MHz)	Channel	Freq. (MHz)
Straddle Channel	138 [#]	5690	144	5720
	142*	5710		

Note:

1. The above Frequency and Channel in "*" were 802.11n HT40 and 802.11ac VHT40.
2. The above Frequency and Channel in "[#]" were 802.11ac VHT80.

2.2 Test Mode

Final test modes are considering the modulation and worse data rates as below table.

Modulation	Data Rate
802.11ac VHT80	MCS0

Ch. #	Band I : 5150-5250 MHz		Band II : 5250-5350 MHz	
	802.11ac VHT80		802.11ac VHT80	
L	Low	-	-	
M	Middle	42	58	
H	High	-	-	
Straddle		-	-	

Ch. #	Band III : 5470-5725MHz	
	802.11ac VHT80	
L	Low	106
M	Middle	-
H	High	-
Straddle		-

2.3 Connection Diagram of Test System

<WLAN Tx Mode>

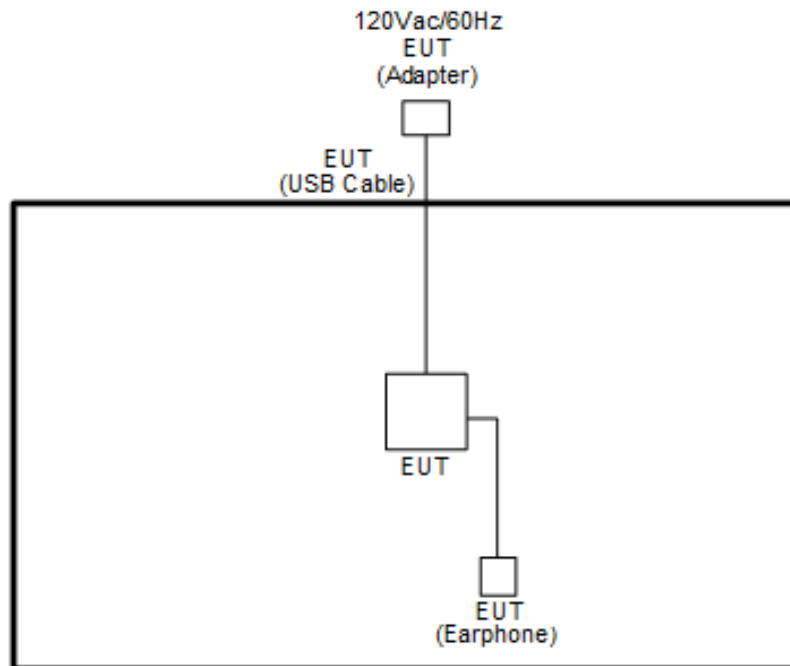

2.4 EUT Operation Test Setup

The RF test items, utility "QRCT" was installed in Notebook which was programmed in order to make the EUT get into the engineering modes to provide channel selection, power level, data rate and the application type and for continuous transmitting signals.



3 Test Result

3.1 Maximum Conducted Output Power Measurement

3.1.1 Limit of Maximum Conducted Output Power

<FCC 14-30 CFR 15.407>

For the 5.15–5.25 GHz bands:

- For mobile and portable client devices in the 5.15–5.25 GHz band, the maximum conducted output power over the frequency band of operation shall not exceed 250 mW. For an indoor access point operating in the band 5.15-5.25 GHz, the maximum conducted output power over the frequency band of operation shall not exceed 1 W.

For the 5.25–5.725 GHz bands:

- The maximum conducted output power over the frequency bands of operation shall not exceed the lesser of 250 mW or $11 \text{ dBm} + 10 \log B$, where B is the 26 dB emission bandwidth in megahertz.

For Straddle Channel, according to KDB 789033 D02 General UNII Test Procedures New Rules v02r01, if the power and PSD of the devices are uniform and comply with the lower limits specified for the U-NII-2 bands, a single measurement over the entire emission bandwidth can be performed to show compliance.

If transmitting antennas of directional gain greater than 6 dBi are used, the peak output power shall be reduced by the amount in dB that the directional gain of the antenna exceeds 6 dBi.

Note that U-NII-2 band, devices with a maximum e.i.r.p. greater than 500 mW shall implement TPC in order to have the capability to operate at least 6 dB below the maximum permitted e.i.r.p. of 1 W.

3.1.2 Measuring Instruments

See list of measuring equipment of this test report.

3.1.3 Test Procedures

The testing follows Method PM of FCC KDB 789033 D02 General UNII Test Procedures New Rules v02r01.

Method PM (Measurement using an RF average power meter):

1. Measurement is performed using a wideband RF power meter.
2. The EUT is configured to transmit continuously with a consistent duty cycle at its maximum power control level.
3. Measure the average power of the transmitter, and the average power is corrected with duty factor, $10 \log(1/x)$, where x is the duty cycle.

For Straddle Channel, according to KDB 789033 D02 General UNII Test Procedures New Rules v02r01, if the power and PSD of the devices are uniform and comply with the lower limits specified for the U-NII-2 bands, a single measurement over the entire emission bandwidth can be performed to show compliance.

3.1.4 Test Setup

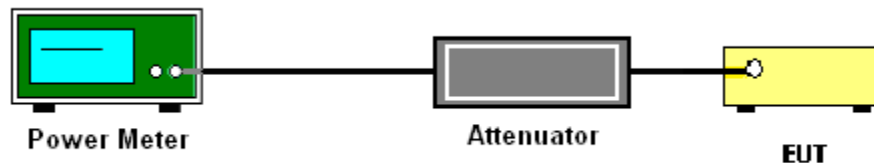

3.1.5 Test Result of Maximum Conducted Output Power

Please refer to Appendix A.



3.2 Unwanted Emissions Measurement

This section is to measure unwanted emissions through radiated measurement for band edge spurious emissions and out of band emissions measurement.

3.2.1 Limit of Unwanted Emissions

- (1) For transmitters operating in the 5150-5250 MHz band: all emissions outside of the 5150-5350 MHz band shall not exceed an EIRP of -27dBm/MHz.

For transmitters operating in the 5250-5350 MHz band: all emissions outside of the 5150-5350 MHz band shall not exceed an EIRP of -27 dBm/MHz. Devices operating in the 5250-5350 MHz band that generate emissions in the 5150-5250 MHz band must meet all applicable technical requirements for operation in the 5150-5250 MHz band (including indoor use) or alternatively meet an out-of-band emission EIRP limit of -27 dBm/MHz in the 5150-5250 MHz band.

For transmitters operating in the 5470-5600 MHz and 5650-5725MHz band: all emissions outside of the 5470-5600 MHz and 5650-5725MHz band shall not exceed an EIRP of -27 dBm/MHz.

- (2) Unwanted spurious emissions fallen in restricted bands shall comply with the general field strength limits as below table,

Frequency (MHz)	Field Strength (microvolts/meter)	Measurement Distance (meters)
0.009 – 0.490	2400/F(kHz)	300
0.490 – 1.705	24000/F(kHz)	30
1.705 – 30.0	30	30
30 – 88	100	3
88 – 216	150	3
216 - 960	200	3
Above 960	500	3

Note: The following formula is used to convert the EIRP to field strength.

$$E = \frac{1000000\sqrt{30P}}{3} \text{ } \mu\text{V/m, where P is the eirp (Watts)}$$



EIRP (dBm)	Field Strength at 3m (dBµV/m)
- 27	68.3

(3) KDB789033 D02 v02r01 G)2)c)

- (i) Section 15.407(b)(1) to (b)(3) specify the unwanted emission limits for the U-NII-1 and U-NII-2 bands. As specified, emissions above 1000 MHz that are outside of the restricted bands are subject to a peak emission limit of -27 dBm/MHz.³
- (ii) Section 15.407(b)(4) specifies the unwanted emission limit for the U-NII-3 band. A band emissions mask is specified in Section 15.407(b)(4)(i). The emission limits are in terms of a Peak detector. An alternative to the band emissions mask is specified in Section 15.407(b)(4)(ii). The alternative limits are based on the highest antenna gain specified in the filing. There are also marketing and importation restrictions for the devices using the alternative limit.⁴

Note 3: An out-of-band emission that complies with both the average and peak limits of Section 15.209 is not required to satisfy the -27 dBm/MHz peak emission limit.

Note 4: Only devices with antenna gains of 10 dBi or less may be approved using the emission limits specified in Section 15.247(d) till March 2, 2018; all other devices operating in this band must use the mask specified in Section 15.407(b)(4)(i).

3.2.2 Measuring Instruments

See list of measuring equipment of this test report.

3.2.3 Test Procedures

1. The testing follows FCC KDB 789033 D02 General UNII Test Procedures New Rules v02r01. Section G) Unwanted emissions measurement.
 - (1) Procedure for Unwanted Emissions Measurements Below 1000MHz
 - RBW = 120 kHz
 - VBW = 300 kHz
 - Detector = Peak
 - Trace mode = max hold
 - (2) Procedure for Peak Unwanted Emissions Measurements Above 1000 MHz
 - RBW = 1 MHz
 - VBW ≥ 3 MHz
 - Detector = Peak
 - Sweep time = auto
 - Trace mode = max hold



(3) Procedures for Average Unwanted Emissions Measurements Above 1000MHz

- RBW = 1 MHz
 - VBW = 10 Hz, when duty cycle is no less than 98 percent.
 - $VBW \geq 1/T$, when duty cycle is less than 98 percent where T is the minimum transmission duration over which the transmitter is on and is transmitting at its maximum power control level for the tested mode of operation.
2. The EUT was placed on a turntable with 0.8 meter for frequency below 1GHz and 1.5 meter for frequency above 1GHz respectively above ground.
 3. The EUT was set 3 meters from the interference receiving antenna which was mounted on the top of a variable height antenna tower.
 4. The antenna is a broadband antenna and its height is adjusted between one meter and four meters above ground to find the maximum value of the field strength for both horizontal polarization and vertical polarization of the antenna.
 5. For each suspected emission, the EUT was arranged to its worst case and then adjust the antenna tower (from 1 m to 4 m) and turntable (from 0 degree to 360 degrees) to find the maximum reading.
 6. For testing below 1GHz, if the emission level of the EUT in peak mode was 3 dB lower than the limit specified, then peak values of EUT will be reported, otherwise, the emissions will be repeated one by one using the CISPR quasi-peak method and reported.
 7. For testing above 1GHz, the emission level of the EUT in peak mode was 20dB lower than average limit (that means the emission level in average mode also complies with the limit in average mode), then peak values of EUT will be reported, otherwise, the emissions will be measured in average mode again and reported.

3.2.4 Test Setup

For radiated emissions below 30MHz

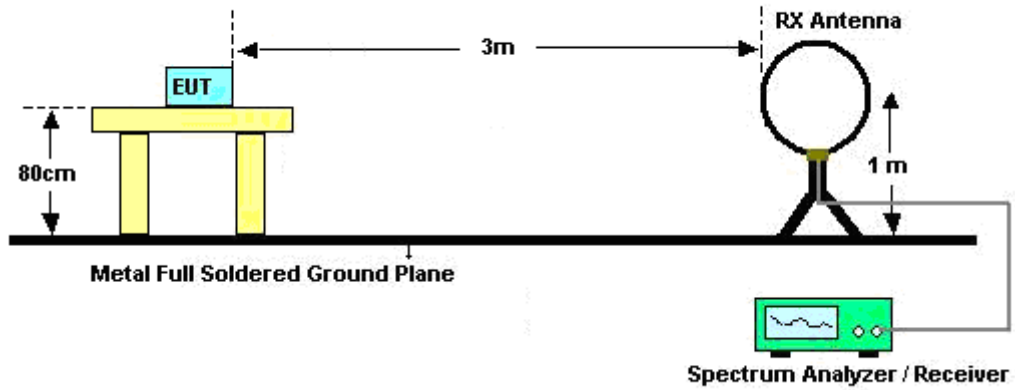

For radiated emissions from 30MHz to 1GHz

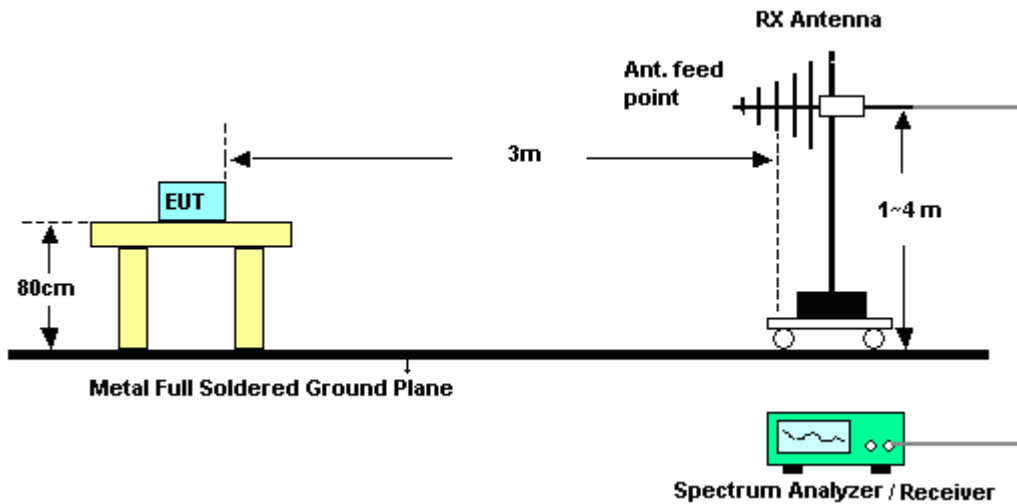

For radiated emissions above 1GHz

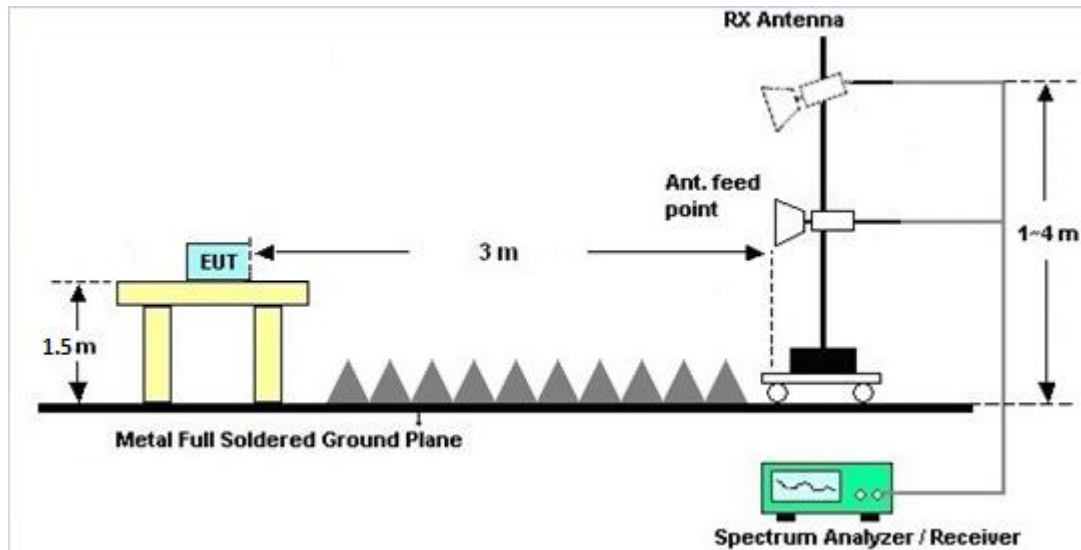

3.2.5 Test Results of Radiated Spurious Emissions (9 kHz ~ 30 MHz)

The low frequency, which started from 9 kHz to 30MHz, was pre-scanned and the result which was 20dB lower than the limit line was not reported.

There is a comparison data of both open-field test site and alternative test site - semi-Anechoic chamber according to 414788 D01 Radiated Test Site v01r01, and the result came out very similar.

3.2.6 Test Result of Radiated Spurious at Band Edges

Please refer to Appendix B and C.

3.2.7 Duty Cycle

Please refer to Appendix D.

3.2.8 Test Result of Radiated Spurious Emissions (30MHz ~ 10th Harmonic)

Please refer to Appendix B and C.



3.3 Automatically Discontinue Transmission

3.3.1 Limit of Automatically Discontinue Transmission

The device shall automatically discontinue transmission in case of either absence of information to transmit or operational failure. These provisions are not intended to preclude the transmission of control or signaling information or the use of repetitive codes used by certain digital technologies to complete frame or burst intervals. Applicants shall include in their application for equipment authorization to describe how this requirement is met.

3.3.2 Measuring Instruments

See list of measuring equipment of this test report.

3.3.3 Test Result of Automatically Discontinue Transmission

While the EUT is not transmitting any information, the EUT can automatically discontinue transmission and become standby mode for power saving. The EUT can detect the controlling signal of ACK message transmitting from remote device and verify whether it shall resend or discontinue transmission.



3.4 Antenna Requirements

3.4.1 Standard Applicable

If transmitting antenna directional gain is greater than 6 dBi, both the peak transmit power and the peak power spectral density shall be reduced by the amount in dB that the directional gain of the antenna exceeds 6 dBi.

3.4.2 Antenna Anti-Replacement Construction

An embedded-in antenna design is used.

3.4.3 Antenna Gain

The antenna peak gain of EUT is less than 6 dBi. Therefore, it is not necessary to reduce maximum peak output power limit.



4 List of Measuring Equipment

Instrument	Manufacturer	Model No.	Serial No.	Characteristics	Calibration Date	Test Date	Due Date	Remark
Hygrometer	Testo	DTM-303A	TP157075	N/A	Mar. 06, 2018	Sep. 10, 2018~ Nov. 01, 2018	Mar. 05, 2019	Conducted (TH05-HY)
Power Meter	Anritsu	ML2495A	1132003	N/A	Aug. 16, 2018	Sep. 10, 2018~ Nov. 01, 2018	Aug. 15, 2019	Conducted (TH05-HY)
Power Sensor	Anritsu	MA2411B	1126017	300MHz~40GHz	Aug. 16, 2018	Sep. 10, 2018~ Nov. 01, 2018	Aug. 15, 2019	Conducted (TH05-HY)
Switch Box & RF Cable	Burgeon	ETF-058	EC1300484	N/A	Mar. 01, 2018	Sep. 10, 2018~ Nov. 01, 2018	Feb. 28, 2019	Conducted (TH05-HY)
Amplifier	MITEQ	TTA1840-35- HG	1871923	18GHz~40GHz, VSWR : 2.5:1 max	Jul. 16, 2018	Sep. 12, 2018~ Nov. 09, 2018	Jul. 15, 2019	Radiation (03CH11-HY)
Amplifier	SONOMA	310N	187312	9kHz~1GHz	Jan. 16, 2018	Sep. 12, 2018~ Nov. 09, 2018	Jan. 15, 2019	Radiation (03CH11-HY)
Bilog Antenna	TESEQ	CBL 6111D &00800N1D 01N-06	35413&02	30MHz~1GHz	Dec. 18, 2017	Sep. 12, 2018~ Nov. 09, 2018	Dec. 17, 2018	Radiation (03CH11-HY)
Horn Antenna	SCHWARZBE CK	BBHA 9120 D	9120D-1326	1GHz ~ 18GHz	Jun. 29, 2018	Sep. 12, 2018~ Nov. 09, 2018	Jun. 28, 2019	Radiation (03CH11-HY)
Hygrometer	TECPEL	DTN-303B	TP161233	N/A	May 12, 2018	Sep. 12, 2018~ Nov. 09, 2018	May 11, 2019	Radiation (03CH11-HY)
Loop Antenna	Rohde & Schwarz	HFH2-Z2	100488	9 kHz~30 MHz	Nov. 23, 2017	Sep. 12, 2018~ Nov. 09, 2018	Nov. 22, 2018	Radiation (03CH11-HY)
Preamplifier	Keysight	83017A	MY5327008 0	1GHz~26.5GHz	Jan. 16, 2018	Sep. 12, 2018~ Nov. 09, 2018	Jan. 15, 2020	Radiation (03CH11-HY)
Spectrum Analyzer	Keysight	N9010A	MY5420048 6	10Hz ~ 44GHz	Oct. 19, 2017	Sep. 12, 2018~ Oct. 17, 2018	Oct. 18, 2018	Radiation (03CH11-HY)
Spectrum Analyzer	Keysight	N9010A	MY5420048 6	10Hz ~ 44GHz	Oct. 17, 2018	Oct. 18, 2018~ Nov. 09, 2018	Oct. 16, 2019	Radiation (03CH11-HY)
Controller	EMEC	EM 1000	N/A	Control Turn table & Ant Mast	N/A	Sep. 12, 2018~ Nov. 09, 2018	N/A	Radiation (03CH11-HY)
Antenna Mast	EMEC	AM-BS-4500 -B	N/A	1~4m	N/A	Sep. 12, 2018~ Nov. 09, 2018	N/A	Radiation (03CH11-HY)
Turn Table	EMEC	TT 2000	N/A	0~360 Degree	N/A	Sep. 12, 2018~ Nov. 09, 2018	N/A	Radiation (03CH11-HY)
Preamplifier	Jet-Power	JPA0118-55- 303K	1710001800 054002	1GHz~18GHz	Apr. 17, 2018	Sep. 12, 2018~ Nov. 09, 2018	Apr. 16, 2019	Radiation (03CH11-HY)
SHF-EHF Horn Antenna	SCHWARZBE CK	BBHA 9170	BBHA91705 84	18GHz- 40GHz	Nov. 27, 2017	Sep. 12, 2018~ Nov. 09, 2018	Nov. 26, 2018	Radiation (03CH11-HY)



Instrument	Manufacturer	Model No.	Serial No.	Characteristics	Calibration Date	Test Date	Due Date	Remark
Software	Audix	E3 6.2009-8-24	RK-001042	N/A	N/A	Sep. 12, 2018~ Nov. 09, 2018	N/A	Radiation (03CH11-HY)
RF Cable	HUBER + SUHNER	SUCOFLEX 104	MY9837/4P E	9kHz-30MHz	Mar. 14, 2018	Sep. 12, 2018~ Nov. 09, 2018	Mar. 13, 2019	Radiation (03CH11-HY)
RF Cable	HUBER + SUHNER	SUCOFLEX 102	MY2859/2	30MHz-40GHz	Mar. 14, 2018	Sep. 12, 2018~ Nov. 09, 2018	Mar. 13, 2019	Radiation (03CH11-HY)
RF Cable	HUBER + SUHNER	SUCOFLEX 104	MY9837/4P E	30M-18G	Mar. 14, 2018	Sep. 12, 2018~ Nov. 09, 2018	Mar. 13, 2019	Radiation (03CH11-HY)
RF Cable	HUBER + SUHNER	SUCOFLEX 102	MY4274/2	30MHz-40GHz	Mar. 14, 2018	Sep. 12, 2018~ Nov. 09, 2018	Mar. 13, 2019	Radiation (03CH11-HY)
Filter	Wainwright	WLK4-1000- 1530-8000-4 0SS	SN11	1G Low Pass	Sep. 18, 2017	Sep. 12, 2018~ Sep. 16, 2018	Sep. 17, 2018	Radiation (03CH11-HY)
Filter	Wainwright	WLK4-1000- 1530-8000-4 0SS	SN11	1G Low Pass	Sep. 16, 2018	Sep. 17, 2018~ Nov. 09, 2018	Sep. 15, 2019	Radiation (03CH11-HY)
Filter	Wainwright	WHKX12-27 00-3000-180 00-60SS	SN2	3G High Pass	Sep. 18, 2017	Sep. 12, 2018~ Sep. 16, 2018	Sep. 17, 2018	Radiation (03CH11-HY)
Filter	Wainwright	WHKX12-27 00-3000-180 00-60SS	SN2	3G High Pass	Sep. 16, 2018	Sep. 17, 2018~ Nov. 09, 2018	Sep. 15, 2019	Radiation (03CH11-HY)
Filter	Wainwright	WHKX8-587 2.5-6750-18 000-40ST	SN3	6.75GHz High Pass	Sep. 18, 2017	Sep. 12, 2018~ Sep. 16, 2018	Sep. 17, 2018	Radiation (03CH11-HY)
Filter	Wainwright	WHKX8-587 2.5-6750-18 000-40ST	SN3	6.75GHz High Pass	Sep. 16, 2018	Sep. 17, 2018~ Nov. 09, 2018	Sep. 15, 2019	Radiation (03CH11-HY)



5 Uncertainty of Evaluation

Uncertainty of Radiated Emission Measurement (30 MHz ~ 1000 MHz)

Measuring Uncertainty for a Level of Confidence of 95% ($U = 2Uc(y)$)	5.20
---	------

Uncertainty of Radiated Emission Measurement (1000 MHz ~ 18000 MHz)

Measuring Uncertainty for a Level of Confidence of 95% ($U = 2Uc(y)$)	5.50
---	------

Uncertainty of Radiated Emission Measurement (18000 MHz ~ 40000 MHz)

Measuring Uncertainty for a Level of Confidence of 95% ($U = 2Uc(y)$)	5.20
---	------

Appendix A. Test Result of Conducted Test Items

Test Engineer:	Luffy Lin	Temperature:	21~25	°C
Test Date:	2018/9/10 ~ 2018/11/01	Relative Humidity:	51~54	%

TEST RESULTS DATA
Average Power Table

FCC Band I														
Mod.	Data Rate	NTX	CH.	Freq. (MHz)	Duty Factor (dB)		Average Conducted Power (dBm)			FCC Conducted Power Limit (dBm)		DG (dBi)		Pass/Fail
					Ant 1	Ant 2	Ant 1	Ant 2	SUM	Ant 1	Ant 2	Ant 1	Ant 2	
11a	6Mbps	1	36	5180	0.23	-	13.48	-		24.00	-	-3.30	-	Pass
11a	6Mbps	1	44	5220	0.23	-	13.46	-		24.00	-	-3.30	-	Pass
11a	6Mbps	1	48	5240	0.23	-	13.44	-		24.00	-	-3.30	-	Pass
HT20	MCS0	1	36	5180	0.22	-	9.23	-		24.00	-	-3.30	-	Pass
HT20	MCS0	1	44	5220	0.22	-	9.35	-		24.00	-	-3.30	-	Pass
HT20	MCS0	1	48	5240	0.22	-	9.42	-		24.00	-	-3.30	-	Pass
HT40	MCS0	1	38	5190	0.41	-	8.26	-		24.00	-	-3.30	-	Pass
HT40	MCS0	1	46	5230	0.41	-	8.33	-		24.00	-	-3.30	-	Pass
VHT20	MCS0	1	36	5180	0.26	-	9.29	-		24.00	-	-3.30	-	Pass
VHT20	MCS0	1	44	5220	0.26	-	9.42	-		24.00	-	-3.30	-	Pass
VHT20	MCS0	1	48	5240	0.26	-	9.48	-		24.00	-	-3.30	-	Pass
VHT40	MCS0	1	38	5190	0.43	-	9.25	-		24.00	-	-3.30	-	Pass
VHT40	MCS0	1	46	5230	0.43	-	9.40	-		24.00	-	-3.30	-	Pass
VHT80	MCS0	1	42	5210	0.58	-	8.13	-		24.00	-	-3.30	-	Pass

TEST RESULTS DATA
Average Power Table

FCC Band II															
Mod.	Data Rate	NTX	CH.	Freq. (MHz)	Duty Factor (dB)		Average Conducted Power (dBm)			FCC Conducted Power Limit (dBm)		DG (dBi)		EIRP Power Limit (dBm)	Pass/Fail
					Ant 1	Ant 2	Ant 1	Ant 2	SUM	Ant 1	Ant 2	Ant 1	Ant 2		
11a	6Mbps	1	52	5260	0.23	-	13.41	-		-	-	-2.80	-	26.99	Pass
11a	6Mbps	1	60	5300	0.23	-	13.38	-		-	-	-2.80	-	26.99	Pass
11a	6Mbps	1	64	5320	0.23	-	13.44	-		-	-	-2.80	-	26.99	Pass
HT20	MCS0	1	52	5260	0.22	-	9.36	-		-	-	-2.80	-	26.99	Pass
HT20	MCS0	1	60	5300	0.22	-	9.32	-		-	-	-2.80	-	26.99	Pass
HT20	MCS0	1	64	5320	0.22	-	9.40	-		-	-	-2.80	-	26.99	Pass
HT40	MCS0	1	54	5270	0.41	-	8.47	-		-	-	-2.80	-	26.99	Pass
HT40	MCS0	1	62	5310	0.41	-	8.38	-		-	-	-2.80	-	26.99	Pass
VHT20	MCS0	1	52	5260	0.26	-	9.42	-		-	-	-2.80	-	26.99	Pass
VHT20	MCS0	1	60	5300	0.26	-	9.41	-		-	-	-2.80	-	26.99	Pass
VHT20	MCS0	1	64	5320	0.26	-	9.43	-		-	-	-2.80	-	26.99	Pass
VHT40	MCS0	1	54	5270	0.43	-	9.48	-		-	-	-2.80	-	26.99	Pass
VHT40	MCS0	1	62	5310	0.43	-	9.41	-		-	-	-2.80	-	26.99	Pass
VHT80	MCS0	1	58	5290	0.58	-	8.22	-		-	-	-2.80	-	26.99	Pass

TEST RESULTS DATA
Average Power Table

FCC Band III															
Mod.	Data Rate	NTX	CH.	Freq. (MHz)	Duty Factor (dB)		Average Conducted Power (dBm)			FCC Conducted Power Limit (dBm)		DG (dBi)		EIRP Power Limit (dBm)	Pass/Fail
					Ant 1	Ant 2	Ant 1	Ant 2	SUM	Ant 1	Ant 2	Ant 1	Ant 2		
11a	6Mbps	1	100	5500	0.23	-	13.22	-		-	-	-2.40	-	26.99	Pass
11a	6Mbps	1	116	5580	0.23	-	13.16	-		-	-	-2.40	-	26.99	Pass
11a	6Mbps	1	140	5700	0.23	-	13.09	-		-	-	-2.40	-	26.99	Pass
11a	6Mbps	1	144	5720	0.23	-	13.28	-		-	-	-2.40	-	26.99	Pass
HT20	MCS0	1	100	5500	0.22	-	9.30	-		-	-	-2.40	-	26.99	Pass
HT20	MCS0	1	116	5580	0.22	-	9.14	-		-	-	-2.40	-	26.99	Pass
HT20	MCS0	1	140	5700	0.22	-	9.17	-		-	-	-2.40	-	26.99	Pass
HT20	MCS0	1	144	5720	0.22	-	9.20	-		-	-	-2.40	-	26.99	Pass
HT40	MCS0	1	102	5510	0.41	-	8.33	-		-	-	-2.40	-	26.99	Pass
HT40	MCS0	1	110	5550	0.41	-	8.36	-		-	-	-2.40	-	26.99	Pass
HT40	MCS0	1	134	5670	0.41	-	8.23	-		-	-	-2.40	-	26.99	Pass
HT40	MCS0	1	142	5710	0.41	-	8.22	-		-	-	-2.40	-	26.99	Pass
VHT20	MCS0	1	100	5500	0.26	-	9.36	-		-	-	-2.40	-	26.99	Pass
VHT20	MCS0	1	116	5580	0.26	-	9.49	-		-	-	-2.40	-	26.99	Pass
VHT20	MCS0	1	140	5700	0.26	-	9.24	-		-	-	-2.40	-	26.99	Pass
VHT20	MCS0	1	144	5720	0.26	-	9.22	-		-	-	-2.40	-	26.99	Pass
VHT40	MCS0	1	102	5510	0.43	-	9.36	-		-	-	-2.40	-	26.99	Pass
VHT40	MCS0	1	110	5550	0.43	-	9.40	-		-	-	-2.40	-	26.99	Pass
VHT40	MCS0	1	134	5670	0.43	-	9.34	-		-	-	-2.40	-	26.99	Pass
VHT40	MCS0	1	142	5710	0.43	-	9.37	-		-	-	-2.40	-	26.99	Pass
VHT80	MCS0	1	106	5530	0.58	-	8.15	-		-	-	-2.40	-	26.99	Pass
VHT80	MCS0	1	122	5610	0.58	-	8.33	-		-	-	-2.40	-	26.99	Pass
VHT80	MCS0	1	138	5690	0.58	-	8.31	-		-	-	-2.40	-	26.99	Pass



Appendix B. Radiated Spurious Emission

Test Engineer :	Hao Hsu, Ken Wu, and Chuan Zhu	Temperature :	21~26°C
		Relative Humidity :	51~56%

Band 1 - 5150~5250MHz

WIFI 802.11ac VHT80 (Band Edge @ 3m)

WIFI	Note	Frequency	Level	Over	Limit	Read	Antenna	Path	Preamp	Ant	Table	Peak	Pol.
Ant.				Limit	Line	Level	Factor	Loss	Factor	Pos	Pos	Avg.	
1		(MHz)	(dBµV/m)	(dB)	(dBµV/m)	(dBµV)	(dB/m)	(dB)	(dB)	(cm)	(deg)	(P/A)	(H/V)
802.11ac VHT80 CH 42 5210MHz		5131.92	59.09	-14.91	74	50.6	31.86	9.66	33.03	100	233	P	H
		5149.94	45.21	-8.79	54	36.66	31.9	9.68	33.03	100	233	A	H
	*	5210	99.99	-	-	91.7	31.56	9.76	33.03	100	233	P	H
	*	5210	92.03	-	-	83.74	31.56	9.76	33.03	100	233	A	H
		5391.62	50.11	-23.89	74	41.74	31.55	9.84	33.02	100	233	P	H
		5451.68	40.52	-13.48	54	31.94	31.71	9.89	33.02	100	233	A	H
		5091.12	49.52	-24.48	74	41.2	31.76	9.6	33.04	394	146	P	V
		5132.26	42.09	-11.91	54	33.6	31.86	9.66	33.03	394	146	A	V
	*	5210	93.62	-	-	85.33	31.56	9.76	33.03	394	146	P	V
	*	5210	85.38	-	-	77.09	31.56	9.76	33.03	394	146	A	V
		5397.34	48.57	-25.43	74	40.17	31.58	9.84	33.02	394	146	P	V
	5458.44	40.4	-13.6	54	31.8	31.73	9.89	33.02	394	146	A	V	
Remark	1. No other spurious found. 2. All results are PASS against Peak and Average limit line.												



**Band 1 5150~5250MHz
WIFI 802.11ac VHT80 (Harmonic @ 3m)**

WIFI	Note	Frequency	Level	Over	Limit	Read	Antenna	Path	Preamp	Ant	Table	Peak	Pol.
Ant.				Limit	Line	Level	Factor	Loss	Factor	Pos	Pos	Avg.	
1		(MHz)	(dBμV/m)	(dB)	(dBμV/m)	(dBμV)	(dB/m)	(dB)	(dB)	(cm)	(deg)	(P/A)	(H/V)
802.11ac VHT80		10420	45.2	-23	68.2	50.24	39.7	15.38	60.12	100	0	P	H
		15630	43.72	-30.28	74	44.96	37.85	18.82	57.91	100	0	P	H
													H
													H
CH 42 5210MHz		10420	43.98	-24.22	68.2	49.02	39.7	15.38	60.12	100	0	P	V
		15630	43.53	-30.47	74	44.77	37.85	18.82	57.91	100	0	P	V
													V
													V
Remark	1. No other spurious found. 2. All results are PASS against Peak and Average limit line.												



**Band 2 - 5250~5350MHz
WIFI 802.11ac VHT80 (Band Edge @ 3m)**

WIFI	Note	Frequency	Level	Over	Limit	Read	Antenna	Path	Preamp	Ant	Table	Peak	Pol.
Ant.				Limit	Line	Level	Factor	Loss	Factor	Pos	Pos	Avg.	
1		(MHz)	(dBμV/m)	(dB)	(dBμV/m)	(dBμV)	(dB/m)	(dB)	(dB)	(cm)	(deg)	(P/A)	(H/V)
802.11ac VHT80 CH 58 5290MHz		5144.9	51.69	-22.31	74	43.15	31.89	9.68	33.03	100	233	P	H
		5144.3	41.82	-12.18	54	33.28	31.89	9.68	33.03	100	233	A	H
	*	5290	98.87	-	-	90.78	31.32	9.8	33.03	100	233	P	H
	*	5290	90.61	-	-	82.52	31.32	9.8	33.03	100	233	A	H
		5353.68	60.23	-13.77	74	52.12	31.32	9.82	33.03	100	233	P	H
		5351.04	48.83	-5.17	54	40.73	31.31	9.82	33.03	100	233	A	H
		5135.6	49.45	-24.55	74	40.95	31.87	9.66	33.03	400	173	P	V
		5113.7	41.6	-12.4	54	33.18	31.83	9.63	33.04	400	173	A	V
	*	5290	94.4	-	-	86.31	31.32	9.8	33.03	400	173	P	V
	*	5290	86.03	-	-	77.94	31.32	9.8	33.03	400	173	A	V
		5415.84	49.05	-24.95	74	40.59	31.63	9.85	33.02	400	173	P	V
	5350.8	41.49	-12.51	54	33.4	31.3	9.82	33.03	400	173	A	V	
Remark	1. No other spurious found. 2. All results are PASS against Peak and Average limit line.												



Band 2 5250~5350MHz
WIFI 802.11ac VHT80 (Harmonic @ 3m)

WIFI	Note	Frequency	Level	Over	Limit	Read	Antenna	Path	Preamp	Ant	Table	Peak	Pol.
Ant.				Limit	Line	Level	Factor	Loss	Factor	Pos	Pos	Avg.	
1		(MHz)	(dBμV/m)	(dB)	(dBμV/m)	(dBμV)	(dB/m)	(dB)	(dB)	(cm)	(deg)	(P/A)	(H/V)
802.11ac VHT80 CH 58 5290MHz		10580	43.79	-24.41	68.2	49.13	39.7	15.47	60.51	100	0	P	H
		15870	43.31	-30.69	74	44.66	37.32	18.9	57.57	100	0	P	H
													H
													H
		10580	44.83	-23.37	68.2	50.17	39.7	15.47	60.51	100	0	P	V
		15870	43.15	-30.85	74	44.5	37.32	18.9	57.57	100	0	P	V
													V
Remark	1. No other spurious found.												
	2. All results are PASS against Peak and Average limit line.												



Band 3 - 5470~5725MHz
WIFI 802.11ac VHT80 (Band Edge @ 3m)

WIFI	Note	Frequency	Level	Over	Limit	Read	Antenna	Path	Preamp	Ant	Table	Peak	Pol.
Ant.				Limit	Line	Level	Factor	Loss	Factor	Pos	Pos	Avg.	
1		(MHz)	(dBμV/m)	(dB)	(dBμV/m)	(dBμV)	(dB/m)	(dB)	(dB)	(cm)	(deg)	(P/A)	(H/V)
802.11ac VHT80 CH 106 5530MHz		5459.44	58.55	-15.45	74	49.94	31.74	9.89	33.02	100	241	P	H
		5463.28	60.31	-7.89	68.2	51.68	31.75	9.9	33.02	100	241	P	H
		5458	45.63	-8.37	54	37.03	31.73	9.89	33.02	100	241	A	H
	*	5530	97.19	-	-	88.44	31.84	9.96	33.05	100	241	P	H
	*	5530	89.06	-	-	80.31	31.84	9.96	33.05	100	241	A	H
		5736.965	50.74	-17.46	68.2	41.61	32.07	10.21	33.15	100	241	P	H
		5437.12	49.29	-24.71	74	40.77	31.67	9.87	33.02	385	174	P	V
		5463.76	48.86	-19.34	68.2	40.22	31.76	9.9	33.02	385	174	P	V
		5450.32	41.2	-12.8	54	32.63	31.7	9.89	33.02	385	174	A	V
	*	5530	93.99	-	-	85.24	31.84	9.96	33.05	385	174	P	V
	*	5530	85.36	-	-	76.61	31.84	9.96	33.05	385	174	A	V
	5730.35	50.28	-17.92	68.2	41.17	32.06	10.2	33.15	385	174	P	V	
Remark	1. No other spurious found. 2. All results are PASS against Peak and Average limit line.												



Band 3 5470~5725MHz
WIFI 802.11ac VHT80 (Harmonic @ 3m)

Table with 14 columns: WIFI, Note, Frequency, Level, Over, Limit, Read, Antenna, Path, Preamp, Ant, Table, Peak, Pol. It contains test data for 802.11ac VHT80 CH 106 at 5530MHz and a Remark section.



Emission below 1GHz

WIFI 802.11ac VHT80 (LF @ 3m)

WIFI	Note	Frequency	Level	Over	Limit	Read	Antenna	Path	Preamp	Ant	Table	Peak	Pol.	
Ant.				Limit	Line	Level	Factor	Loss	Factor	Pos	Pos	Avg.		
1		(MHz)	(dBμV/m)	(dB)	(dBμV/m)	(dBμV)	(dB/m)	(dB)	(dB)	(cm)	(deg)	(P/A)	(H/V)	
802.11ac VHT80 LF		65.1	23.21	-16.79	40	43	11.61	1.09	32.49	-	-	P	H	
		146.1	32.75	-10.75	43.5	46.47	17.05	1.67	32.44	-	-	P	H	
		167.43	33.89	-9.61	43.5	48.92	15.59	1.8	32.42	-	-	P	H	
		591.9	29.75	-16.25	46	33.54	25.48	3.18	32.45	-	-	P	H	
		701.1	34.75	-11.25	46	37.14	26.6	3.48	32.47	-	-	P	H	
		757.1	36.5	-9.5	46	37.28	27.87	3.65	32.3	100	122	P	H	
													H	
													H	
													H	
													H	
													H	
													H	
			35.94	29.82	-10.18	40	40.21	21.29	0.81	32.49	-	-	P	V
			66.18	30.11	-9.89	40	49.79	11.7	1.11	32.49	100	286	P	V
			157.98	31.76	-11.74	43.5	45.98	16.46	1.75	32.43	-	-	P	V
			682.9	32.82	-13.18	46	35.32	26.53	3.44	32.47	-	-	P	V
			748.7	34.06	-11.94	46	34.95	27.8	3.64	32.33	-	-	P	V
			958.7	33.61	-12.39	46	29.62	30.95	4.16	31.12	-	-	P	V
														V
														V
													V	
													V	
													V	
													V	
Remark	1. No other spurious found. 2. All results are PASS against limit line.													



Note symbol

*	Fundamental Frequency which can be ignored. However, the level of any unwanted emissions shall not exceed the level of the fundamental frequency.
!	Test result is over limit line.
P/A	Peak or Average
H/V	Horizontal or Vertical



A calculation example for radiated spurious emission is shown as below:

WIFI	Note	Frequency	Level	Over	Limit	Read	Antenna	Path	Preamp	Ant	Table	Peak	Pol.
Ant.				Limit	Line	Level	Factor	Loss	Factor	Pos	Pos	Avg.	
1		(MHz)	(dBμV/m)	(dB)	(dBμV/m)	(dBμV)	(dB/m)	(dB)	(dB)	(cm)	(deg)	(P/A)	(H/V)
802.11b		2390	55.45	-18.55	74	54.51	32.22	4.58	35.86	103	308	P	H
CH 01													
2412MHz		2390	43.54	-10.46	54	42.6	32.22	4.58	35.86	103	308	A	H

1. Path Loss(dB) = Cable loss(dB) + Filter loss(dB) + Attenuator loss(dB)
2. Level(dBμV/m) = Antenna Factor(dB/m) + Path Loss(dB) + Read Level(dBμV) - Preamp Factor(dB)
3. Over Limit(dB) = Level(dBμV/m) – Limit Line(dBμV/m)

For Peak Limit @ 2390MHz:

1. Level(dBμV/m)
= Antenna Factor(dB/m) + Path Loss(dB) + Read Level(dBμV) - Preamp Factor(dB)
= 32.22(dB/m) + 4.58(dB) + 54.51(dBμV) – 35.86 (dB)
= 55.45 (dBμV/m)
2. Over Limit(dB)
= Level(dBμV/m) – Limit Line(dBμV/m)
= 55.45(dBμV/m) – 74(dBμV/m)
= -18.55(dB)

For Average Limit @ 2390MHz:

1. Level(dBμV/m)
= Antenna Factor(dB/m) + Path Loss(dB) + Read Level(dBμV) - Preamp Factor(dB)
= 32.22(dB/m) + 4.58(dB) + 42.6(dBμV) – 35.86 (dB)
= 43.54 (dBμV/m)
2. Over Limit(dB) = Level(dBμV/m) – Limit Line(dBμV/m)
= 43.54(dBμV/m) – 54(dBμV/m)
= -10.46(dB)

Both peak and average measured complies with the limit line, so test result is “PASS”.



Appendix C. Radiated Spurious Emission

Test Engineer :	Hao Hsu, Ken Wu, and Chuan Zhu	Temperature :	21~26°C
		Relative Humidity :	51~56%

Note symbol

-L	Low channel location
-R	High channel location



Band 1 - 5150~5250MHz
WIFI 802.11ac VHT80 (Band Edge @ 3m)

WIFI	Band 1 5150~5250MHz Band Edge @ 3m	
ANT	802.11ac VHT80 CH42 5210MHz - L	
1	Horizontal	Fundamental
Peak	<p>Site : 03CHI1-HY Condition : PEAK_BE_74 3m HORN 91200-HF HORIZONTAL RBW:1000.000KHz VBW:3000.000KHz SWT:Auto Detector : Peak Project : 881330-01 Siting : 9</p>	<p>Site : 03CHI1-HY Condition : PEAK(LINE) 3m HORN 91200-HF HORIZONTAL RBW:1000.000KHz VBW:3000.000KHz SWT:Auto Detector : Peak Project : 881330-01 Siting : 9</p>
Avg.	<p>Site : 03CHI1-HY Condition : AVG_BE_54 3m HORN 91200-HF HORIZONTAL RBW:1000.000KHz VBW:3.000KHz SWT:Auto Detector : Peak Project : 881330-01 Siting : 9</p>	Left blank

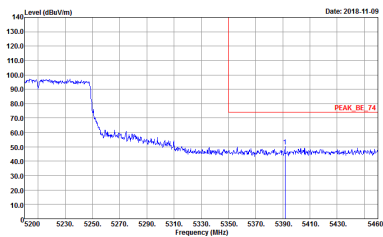
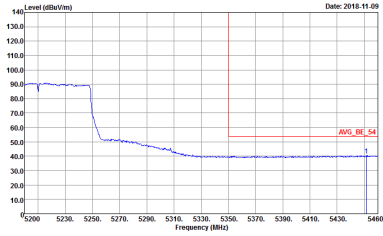

WIFI	Band 1 5150~5250MHz Band Edge @ 3m	
ANT	802.11ac VHT80 CH42 5210MHz - R	
1	Horizontal	Fundamental
<p>Peak</p>	 <p>Site : 03CH11-HY Condition : PEAK_BE_74 3m HORN 91200-HF HORIZONTAL : RBW:1000.000KHz VBW:3000.000KHz SWT:Auto Detector : Peak Project : 881330-01 SThing : 9</p>	<p>Left blank</p>
<p>Avg.</p>	 <p>Site : 03CH11-HY Condition : AVG_BE_54 3m HORN 91200-HF HORIZONTAL : RBW:1000.000KHz VBW:3.000KHz SWT:Auto Detector : Peak Project : 881330-01 SThing : 9</p>	<p>Left blank</p>

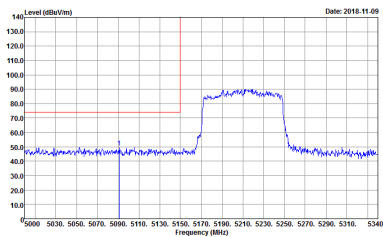
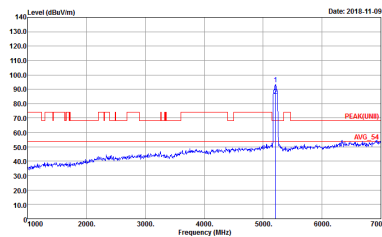
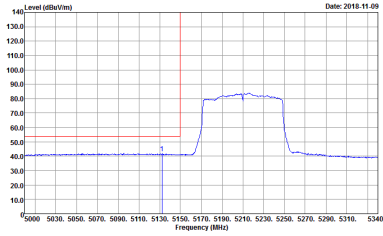

WIFI	Band 1 5150~5250MHz Band Edge @ 3m	
ANT	802.11ac VHT80 CH42 5210MHz - L	
1	Vertical	Fundamental
<p>Peak</p>	 <p>Site : 03CH11-HY Condition : PEAK_BE_74 3m HORN 91200-HF VERTICAL RBW:1000.000KHz VBW:3000.000KHz SWT:Auto Detector : Peak Project : 881330-01 Siting : 9</p>	 <p>Site : 03CH11-HY Condition : PEAK(UNII) 3m HORN 91200-HF VERTICAL RBW:1000.000KHz VBW:3000.000KHz SWT:Auto Detector : Peak Project : 881330-01 Siting : 9</p>
<p>Avg.</p>	 <p>Site : 03CH11-HY Condition : AVG_BE_54 3m HORN 91200-HF VERTICAL RBW:1000.000KHz VBW:3.000KHz SWT:Auto Detector : Peak Project : 881330-01 Siting : 9</p>	<p>Left blank</p>

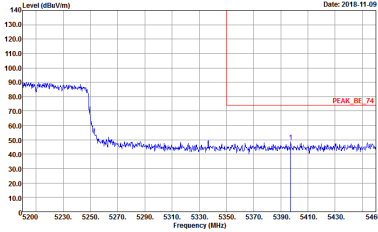
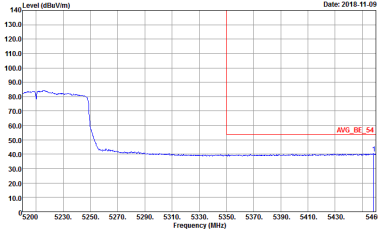

WIFI	Band 1 5150~5250MHz Band Edge @ 3m	
ANT	802.11ac VHT80 CH42 5210MHz - R	
1	Vertical	Fundamental
<p>Peak</p>	 <p>Site : 03CH11-HY Condition : PEAK_BE_74 3m HORN 91200-HF VERTICAL Detector : Peak Project : 881330-01 STring : 9</p>	<p>Left blank</p>
<p>Avg.</p>	 <p>Site : 03CH11-HY Condition : AVG_BE_54 3m HORN 91200-HF VERTICAL Detector : Peak Project : 881330-01 STring : 9</p>	<p>Left blank</p>



Band 1 - 5150~5250MHz
WIFI 802.11ac VHT80 (Harmonic @ 3m)

WIFI	Band 1 5150~5250MHz Harmonic @ 3m	
ANT	802.11ac VHT80 CH42 5210MHz	
1	Horizontal	Vertical
Peak Avg.	<p>Site : 03CH11-HY Condition : PEAR(UNIT) 3m HORN 9120D-HF HORIZZONTAL Detector : Peak Project : 881330-01</p>	<p>Site : 03CH11-HY Condition : PEAR(UNIT) 3m HORN 9120D-HF VERTICAL Detector : Peak Project : 881330-01</p>

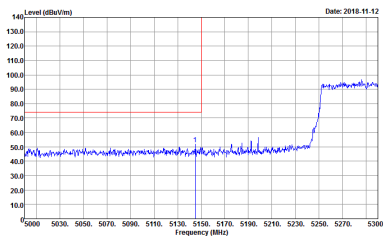
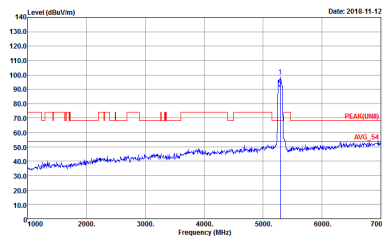
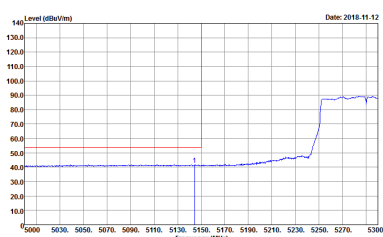

Band 2 - 5250~5350MHz
WIFI 802.11ac VHT80 (Band Edge @ 3m)

WIFI	Band 2 5250~5350MHz Band Edge @ 3m	
ANT	802.11ac VHT80 CH58 5290MHz - L	
1	Horizontal	Fundamental
Peak	 <p>Site : 03CHI1-HY Condition : PEAK_BE_74 3m HORN 91200-HF HORIZONTAL RBW:1000.000KHz VBW:3000.000KHz SWT:Auto Detector : Peak Project : 881330-01 SFlting : 7.5</p>	 <p>Site : 03CHI1-HY Condition : PEAK(LINE) 3m HORN 91200-HF HORIZONTAL RBW:1000.000KHz VBW:3000.000KHz SWT:Auto Detector : Peak Project : 881330-01 SFlting : 7.5</p>
Avg.	 <p>Site : 03CHI1-HY Condition : AVG_BE_54 3m HORN 91200-HF HORIZONTAL RBW:1000.000KHz VBW:3.000KHz SWT:Auto Detector : Peak Project : 881330-01 SFlting : 7.5</p>	Left blank

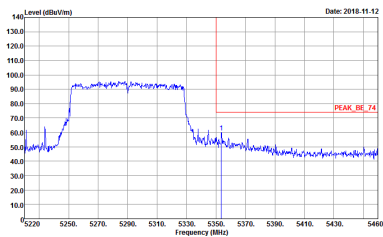
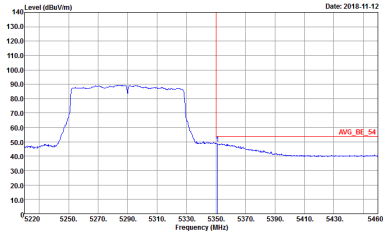

WIFI	Band 2 5250~5350MHz Band Edge @ 3m	
ANT	802.11ac VHT80 CH58 5290MHz - R	
1	Horizontal	Fundamental
<p>Peak</p>	 <p>Site : 03CH11-HY Condition : PEAK_BE_74 3m HORN 91200-HF HORIZONTAL Detector : Peak Project : 881330-01 SFling : 7.5</p>	<p>Left blank</p>
<p>Avg.</p>	 <p>Site : 03CH11-HY Condition : AVG_BE_54 3m HORN 91200-HF HORIZONTAL Detector : Peak Project : 881330-01 SFling : 7.5</p>	<p>Left blank</p>

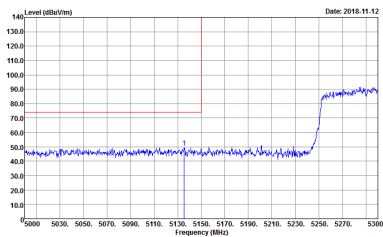
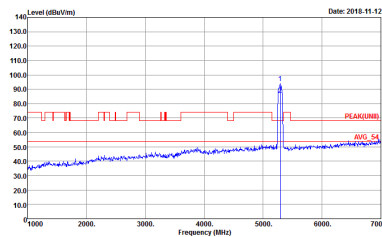
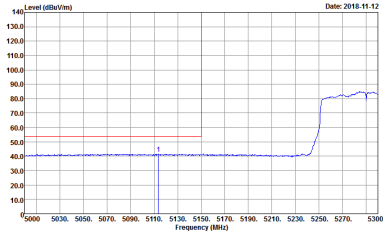

WIFI	Band 2 5250~5350MHz Band Edge @ 3m	
ANT	802.11ac VHT80 CH58 5290MHz - L	
1	Vertical	Fundamental
<p>Peak</p>	 <p>Site : 03CH11-HY Condition : PEAK_BE_74 3m HORN 91200-HF VERTICAL : RBW:1000.000KHz VBW:3000.000KHz SWT:Auto Detector : Peak Project : 881330-01 Siring : 7.5</p>	 <p>Site : 03CH11-HY Condition : PEAK(UNII) 3m HORN 91200-HF VERTICAL : RBW:1000.000KHz VBW:3000.000KHz SWT:Auto Detector : Peak Project : 881330-01 Siring : 7.5</p>
<p>Avg.</p>	 <p>Site : 03CH11-HY Condition : AVG_BE_54 3m HORN 91200-HF VERTICAL : RBW:1000.000KHz VBW:3.000KHz SWT:Auto Detector : Peak Project : 881330-01 Siring : 7.5</p>	<p>Left blank</p>

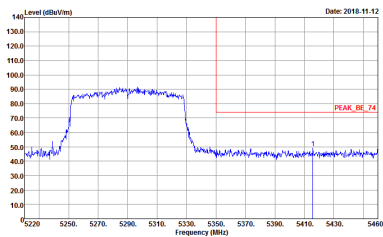
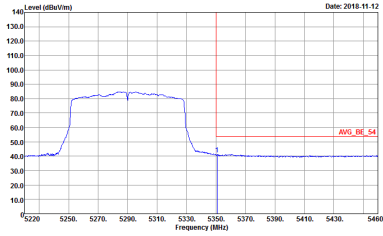

WIFI	Band 2 5250~5350MHz Band Edge @ 3m	
ANT	802.11ac VHT80 CH58 5290MHz - R	
1	Vertical	Fundamental
<p>Peak</p>	 <p>Site : 03CH11-HY Condition : PEAK_BE_74 3m HORN 91200-HF VERTICAL Detector : Peak Project : 881330-01 SFling : 7.5</p>	<p>Left blank</p>
<p>Avg.</p>	 <p>Site : 03CH11-HY Condition : AVG_BE_54 3m HORN 91200-HF VERTICAL Detector : Peak Project : 881330-01 SFling : 7.5</p>	<p>Left blank</p>



Band 2 - 5250~5350MHz
WIFI 802.11ac VHT80 (Harmonic @ 3m)

WIFI	Band 2 5250~5350MHz Harmonic @ 3m	
ANT	802.11ac VHT80 CH58 5290MHz	
1	Horizontal	Vertical
Peak Avg.	<p>Site : 03CH11-HY Condition : PEAR(LINE) 3m HORN 9120D-1HF HORIZZONTAL Detector : Peak Project : 881330-01</p>	<p>Site : 03CH11-HY Condition : PEAR(LINE) 3m HORN 9120D-1HF VERTICAL Detector : Peak Project : 881330-01</p>

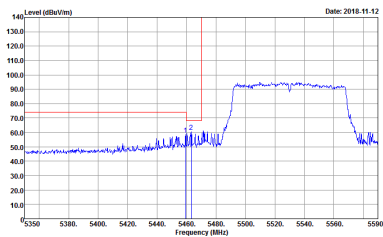
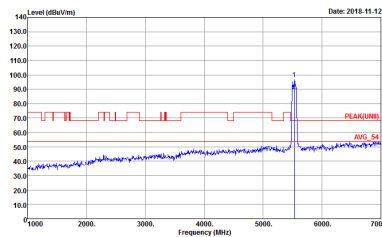
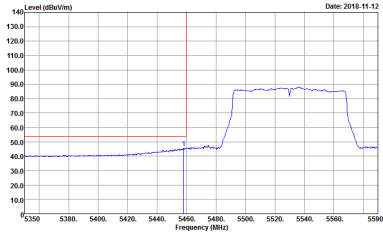

Band 3 - 5470~5725MHz
WIFI 802.11ac VHT80 (Band Edge @ 3m)

WIFI	Band 3 5470~5725MHz Band Edge @ 3m	
ANT	802.11ac VHT80 CH106 5530MHz - L	
1	Horizontal	Fundamental
<p align="center">Peak</p>	 <p>Site : 03CHI1-HY Condition : PEAK_BE(UNIT)_B3 3m HORN 9120D-HF HORIZONTAL Detector : Peak Project : 881330-01 SFling : 8.5</p>	 <p>Site : 03CHI1-HY Condition : PEAK(UNIT) 3m HORN 9120D-HF HORIZONTAL Detector : Peak Project : 881330-01 SFling : 8.5</p>
<p align="center">Avg.</p>	 <p>Site : 03CHI1-HY Condition : AVG_BE(UNIT)_B3 3m HORN 9120D-HF HORIZONTAL Detector : Peak Project : 881330-01 SFling : 8.5</p>	<p align="center">Left blank</p>

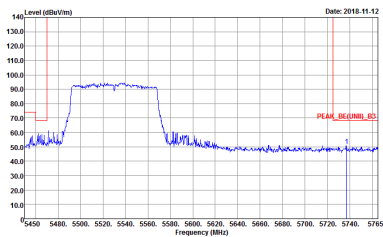

WIFI	Band 3 5470~5725MHz Band Edge @ 3m	
ANT	802.11ac VHT80 CH106 5530MHz - R	
1	Horizontal	Fundamental
Peak	 <p>Site : D8CH11A4Y Condition : PEAK_BE([UNIT], B3 3m HORN 91200-HF HORIZONTAL Detector : Peak Project : 881330-01 S1ring : 8.5</p>	Left blank



WIFI	Band 3 5470~5725MHz Band Edge @ 3m	
ANT	802.11ac VHT80 CH106 5530MHz - L	
1	Vertical	Fundamental
Peak	<p>Site : 03CH11-HY Condition : PEAK_BE(UNIT), B3 3m HORN 9120D-HF VERTICAL : RBW:1000.000KHz VBW:3000.000KHz SWT:Auto Detector : Peak Project : 881330-01 SFlting : 8.5</p>	<p>Site : 03CH11-HY Condition : PEAK(UNIT) 3m HORN 9120D-HF VERTICAL : RBW:1000.000KHz VBW:3000.000KHz SWT:Auto Detector : Peak Project : 881330-01 SFlting : 8.5</p>
Avg.	<p>Site : 03CH11-HY Condition : AVG_BE(UNIT), B3 3m HORN 9120D-HF VERTICAL : RBW:1000.000KHz VBW:3.000KHz SWT:Auto Detector : Peak Project : 881330-01 SFlting : 8.5</p>	Left blank

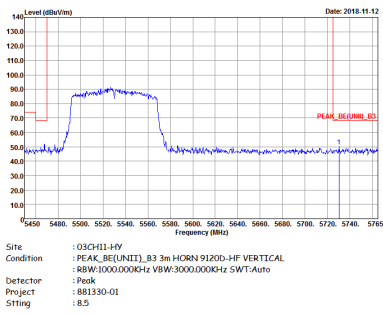

WIFI	Band 3 5470~5725MHz Band Edge @ 3m	
ANT	802.11ac VHT80 CH106 5530MHz - R	
1	Vertical	Fundamental
Peak		Left blank



Band 3 - 5470~5725MHz
WIFI 802.11ac VHT80 (Harmonic @ 3m)

WIFI	Band 3 5470~5725MHz Harmonic @ 3m	
ANT	802.11ac VHT80 CH106 5530MHz	
1	Horizontal	Vertical
Peak Avg.	<p>Site : 03CH11-HY Condition : PEAR(LINE) 3m HORN 9120D-1HF HORIZONTAL Detector : Peak Project : 881330-01</p>	<p>Site : 03CH11-HY Condition : PEAR(LINE) 3m HORN 9120D-1HF VERTICAL Detector : Peak Project : 881330-01</p>



Emission below 1GHz
5GHz WIFI 802.11ac VHT80 (LF)

WIFI	5GHz WIFI	
ANT	802.11ac VHT80 LF	
1	Horizontal	Vertical
QP / Peak	<p>Site : 03CH11-HY Condition : QP 3m BE-LOG-6111D-LF_ETC HORIZONTAL Detector : Peak Project : 881330-01</p>	<p>Site : 03CH11-HY Condition : QP 3m BE-LOG-6111D-LF_ETC VERTICAL Detector : Peak Project : 881330-01</p>



Appendix D. Duty Cycle Plots

Band	Duty Cycle(%)	T(us)	1/T(kHz)	VBW Setting	Duty Factor(dB)
802.11a	94.93	2060	0.49	1kHz	0.23
5GHz 802.11n HT20	95.07	1930	0.52	1kHz	0.22
5GHz 802.11n HT40	90.91	950	1.05	3kHz	0.41
5GHz 802.11ac VHT20	94.17	1940	0.52	1kHz	0.26
5GHz 802.11ac VHT40	90.48	950	1.05	3kHz	0.43
5GHz 802.11ac VHT80	87.50	735	1.36	3kHz	0.58



802.11a

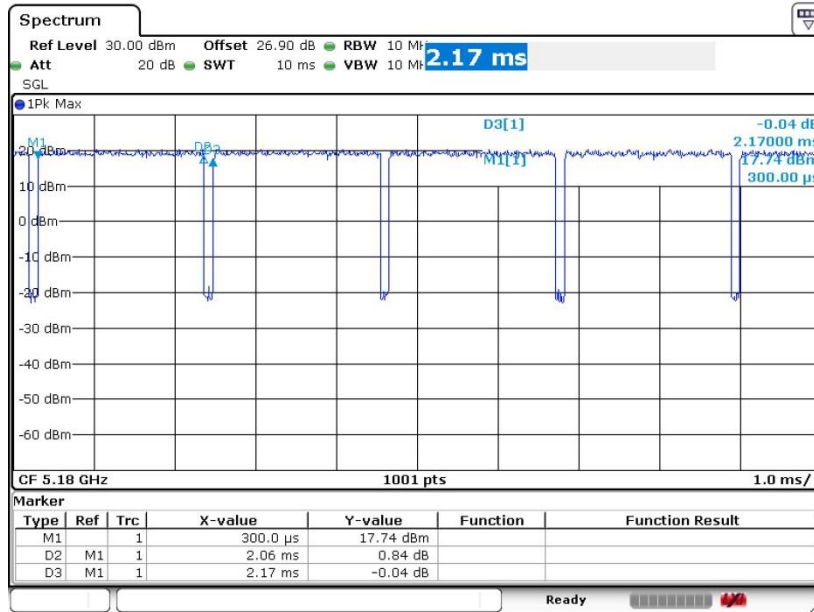

Date: 8.SEP.2018 07:47:13

802.11n HT20

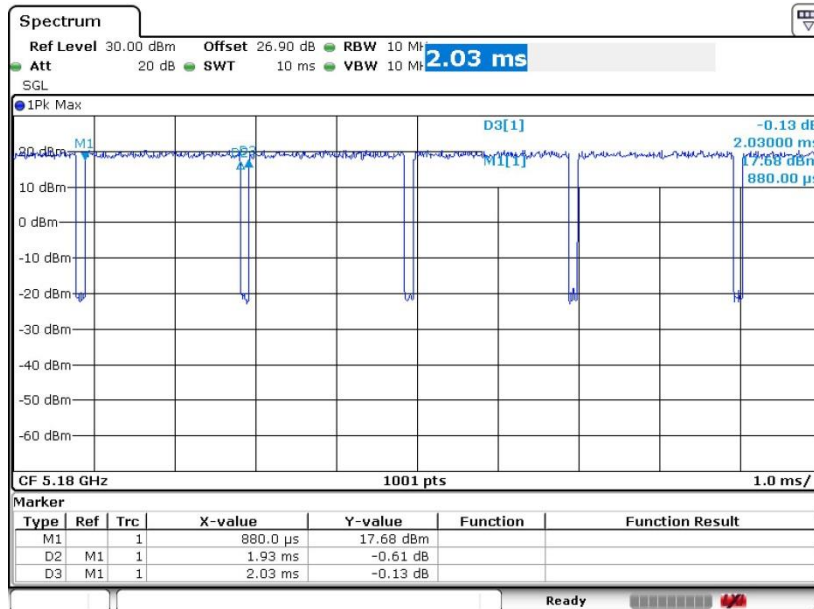

Date: 8.SEP.2018 07:49:33



802.11n HT40

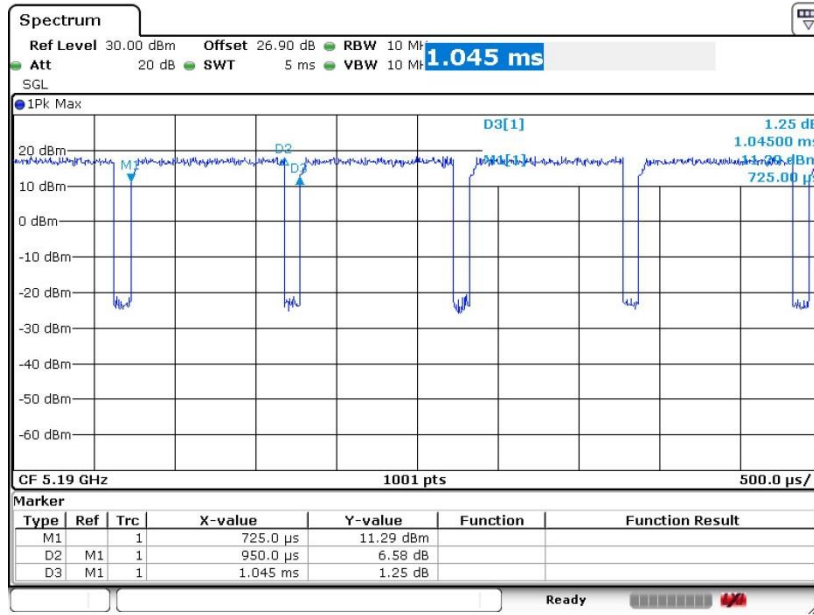

Date: 8.SEP.2018 07:50:51

802.11ac VHT20

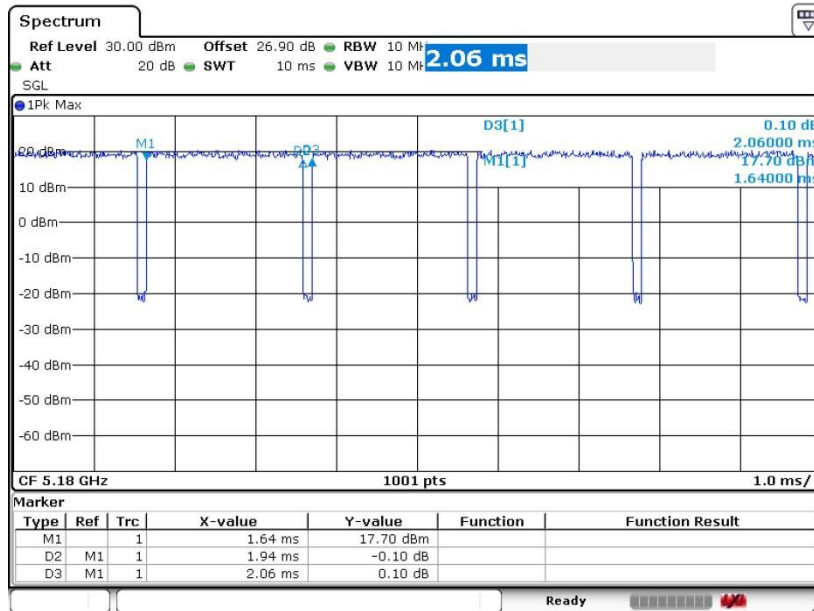

Date: 8.SEP.2018 07:52:02



802.11ac VHT40

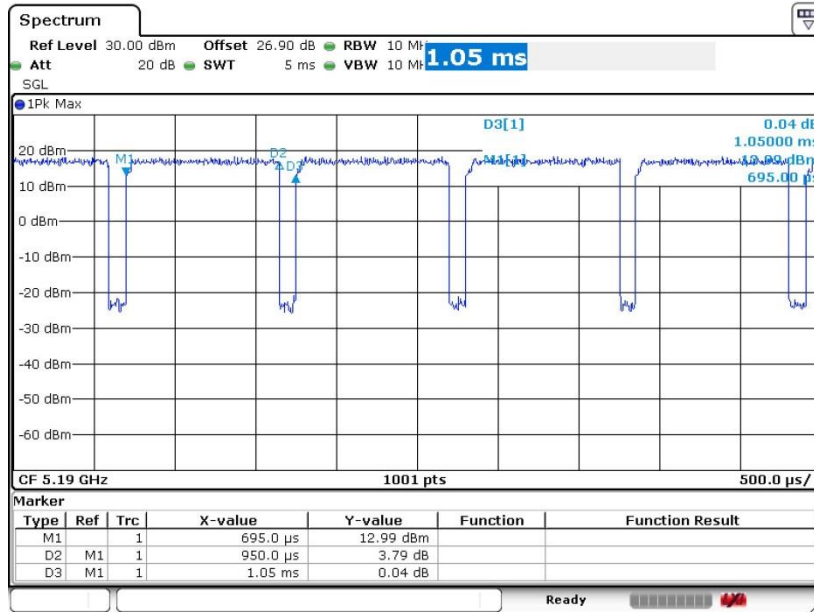

Date: 8.SEP.2018 07:53:21

802.11ac VHT80

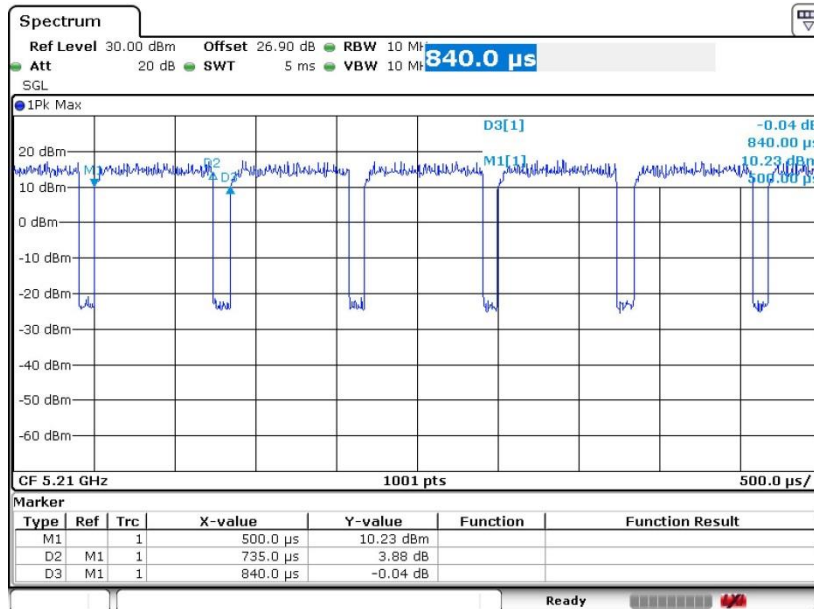

Date: 8.SEP.2018 07:56:07

—————THE END—————