



FCC RADIO TEST REPORT

FCC ID : PY7-34943G
Equipment : GSM/WCDMA/LTE Phone with BT, DTS/UNII
a/b/g/n/ac, NFC and GNSS
Brand Name : SONY
Applicant : Sony Corporation
1-7-1 Konan Minato-ku Tokyo, 108-0076 Japan
Manufacturer : Sony Corporation
1-7-1 Konan Minato-ku Tokyo, 108-0076 Japan
Standard : FCC Part 15 Subpart C §15.247
Test Date(s) : Dec. 20, 2021 ~ Feb. 18, 2022

We, Sporton International Inc. (Kunshan), would like to declare that the tested sample has been evaluated in accordance with the test procedures and has been in compliance with the applicable technical standards.

The test results in this report apply exclusively to the tested model / sample. Without written approval of Sporton International Inc. (Kunshan), the test report shall not be reproduced except in full.

Jason Jia

Reviewed by: Jason Jia / Supervisor

Alex Wang

Approved by: Alex Wang / Manager



Sporton International Inc. (Kunshan)

**No. 1098, Pengxi North Road, Kunshan Economic Development Zone Jiangsu Province 215300
People's Republic of China**



Table of Contents

History of this test report.....3

Summary of Test Result.....4

1 General Description5

 1.1 Product Feature of Equipment Under Test.....5

 1.2 Modification of EUT5

 1.3 Testing Location5

 1.4 Applicable Standards.....6

2 Test Configuration of Equipment Under Test7

 2.1 Carrier Frequency and Channel7

 2.2 Test Mode.....8

 2.3 Connection Diagram of Test System.....9

 2.4 Support Unit used in test configuration and system10

 2.5 EUT Operation Test Setup10

 2.6 Measurement Results Explanation Example.....10

3 Test Result11

 3.1 6dB and 99% Bandwidth Measurement11

 3.2 Output Power Measurement.....12

 3.3 Power Spectral Density Measurement14

 3.4 Conducted Band Edges and Spurious Emission Measurement15

 3.5 Radiated Band Edges and Spurious Emission Measurement16

 3.6 AC Conducted Emission Measurement.....21

 3.7 Antenna Requirements.....23

4 List of Measuring Equipment.....24

5 Uncertainty of Evaluation.....25

Appendix A. Conducted Test Results

Appendix B. AC Conducted Emission Test Result

Appendix C. Radiated Spurious Emission

Appendix D. Radiated Spurious Emission Plots

Appendix E. Duty Cycle Plots



Summary of Test Result

Report Clause	Ref Std. Clause	Test Items	Result (PASS/FAIL)	Remark
3.1	15.247(a)(2)	6dB Bandwidth	Pass	-
3.1	2.1049	99% Occupied Bandwidth	Reporting only	-
3.2	15.247(b)	Power Output Measurement	Pass	-
3.3	15.247(e)	Power Spectral Density	Pass	-
3.4	15.247(d)	Conducted Band Edges	Pass	-
		Conducted Spurious Emission	Pass	-
3.5	15.247(d)	Radiated Band Edges and Radiated Spurious Emission	Pass	Under limit 6.20 dB at 2389.95 MHz
3.6	15.207	AC Conducted Emission	Pass	Under limit 13.53 dB at 0.209 MHz
3.7	15.203 & 15.247(b)	Antenna Requirement	Pass	-

Declaration of Conformity:

The test results with all measurement uncertainty excluded are presented in accordance with the regulation limits or requirements declared by manufacturers.

Comments and Explanations:

The declared of product specification for EUT presented in the report are provided by the manufacturer, and the manufacturer takes all the responsibilities for the accuracy of product specification.



1 General Description

1.1 Product Feature of Equipment Under Test

GSM/WCDMA/LTE/5G NR, Bluetooth, DTS/UNII a/b/g/n/ac, NFC and GNSS.

Standards-related Product Specification	
Antenna Type / Gain	<Ant.6>: PIFA Antenna with gain 2.3 dBi <Ant.7>: PIFA Antenna with gain -2.6 dBi

Remark: The above EUT's information was declared by manufacturer. Please refer to Comments and Explanations in report summary.

EUT Information List			
HW Version	SW Version	IMEI Code	Performed Test Item
A	0.549	004402543254167/ 004402543254175	RF conducted measurement
		004402543253961	Radiated Spurious Emission
		004402543254142/ 004402543254159	AC Conducted Emission

Note: For other wireless features of this EUT, test report will be issued separately.

1.2 Modification of EUT

No modifications are made to the EUT during all test items.

1.3 Testing Location

Sporton International Inc. (Kunshan) is accredited to ISO/IEC 17025:2017 by American Association for Laboratory Accreditation with Certificate Number 5145.02.

Test Firm	Sporton International Inc. (Kunshan)		
Test Site Location	No. 1098, Pengxi North Road, Kunshan Economic Development Zone Jiangsu Province 215300 People's Republic of China TEL : +86-512-57900158 FAX : +86-512-57900958		
Test Site No.	Sporton Site No.	FCC Designation No.	FCC Test Firm Registration No.
	CO01-KS 03CH06-KS TH01-KS	CN1257	314309



1.4 Applicable Standards

According to the specifications of the manufacturer, the EUT must comply with the requirements of the following standards:

- ♦ FCC Part 15 Subpart C §15.247
- ♦ FCC KDB Publication No. 558074 D01 DTS Meas. Guidance v05r02
- ♦ FCC KDB 414788 D01 Radiated Test Site v01r01.
- ♦ FCC KDB 662911 D01 Multiple Transmitter Output v02r01.
- ♦ ANSI C63.10-2013

Remark:

1. All test items were verified and recorded according to the standards and without any deviation during the test.
2. This EUT has also been tested and complied with the requirements of FCC Part 15, Subpart B, recorded in a separate test report.



2 Test Configuration of Equipment Under Test

- a. The EUT has been associated with peripherals and configuration operated in a manner tended to maximize its emission characteristics in a typical application. Frequency range investigated: conduction emission (150 kHz to 30 MHz), radiation emission (9 kHz to the 10th harmonic of the highest fundamental frequency or to 40 GHz, whichever is lower). For radiated measurement, the measured emission level of the EUT was maximized by rotating the EUT on a turntable, adjusting the orientation of the EUT and EUT antenna in three orthogonal axis (X: flat, Y: portrait, Z: landscape), and adjusting the measurement antenna orientation, following C63.10 exploratory test procedures and find X plane as worst plane. The worst case position of the EUT was investigated under two configurations: EUT with AC adapter and earphone, EUT with standalone. The EUT with AC adapter and earphone configuration was determined to be worst-case configurations; therefore, all final tests were performed on the EUT with AC adapter and earphone.
- b. AC power line Conducted Emission was tested under maximum output power.

2.1 Carrier Frequency and Channel

Frequency Band	Channel	Freq. (MHz)	Channel	Freq. (MHz)
2400-2483.5 MHz	1	2412	7	2442
	2	2417	8	2447
	3	2422	9	2452
	4	2427	10	2457
	5	2432	11	2462
	6	2437		



2.2 Test Mode

Final test modes are considering the modulation and worse data rates as below table.

Modulation	Data Rate
802.11b	1 Mbps
802.11g	6 Mbps
802.11n HT20	MCS0

Co-location Mode
WWAN LTE 41 Link + WLAN 2.4GHz 11n20 CH01(Ant.6+7)

Test Cases	
AC Conducted Emission	Mode 1 : GSM850 Idle + Bluetooth Link + WLAN (2.4GHz) Link + Earphone + USB Cable 1(Charging from AC Adapter)

Ch. #	2400-2483.5 MHz		
	802.11b	802.11g	802.11n HT20
Low	01	01	01
Middle	06	06	06
High	11	11	11

Remark: For WLAN radiated test, according to the conducted power and verify test the SISO & MIMO mode, the worst-case is MIMO mode, therefore, all final test are performed in MIMO mode and reported.

2.3 Connection Diagram of Test System

<AC Conducted Emission Mode>

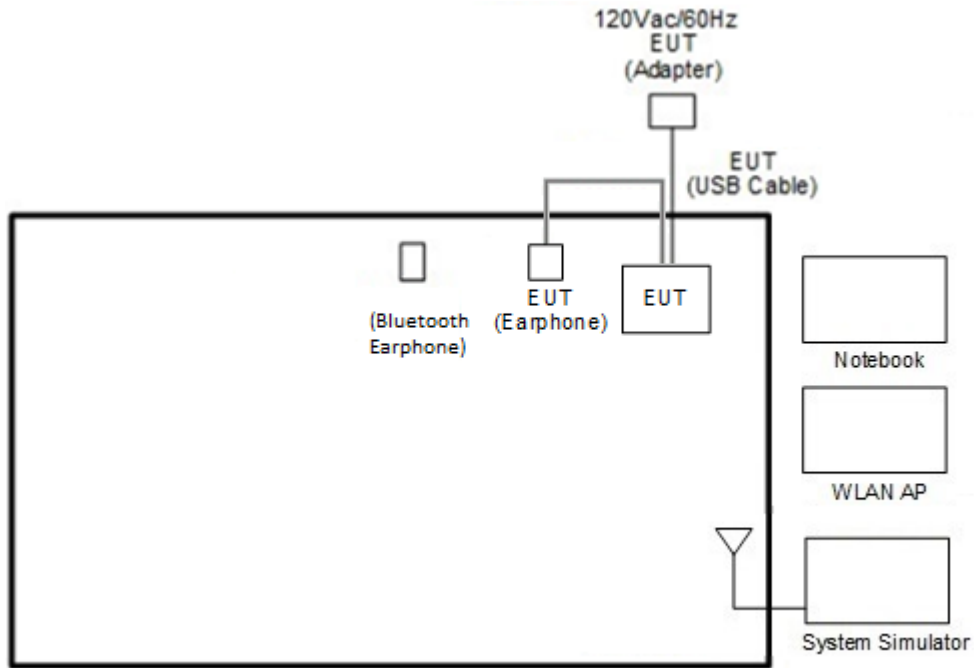

<WLAN TX Mode>

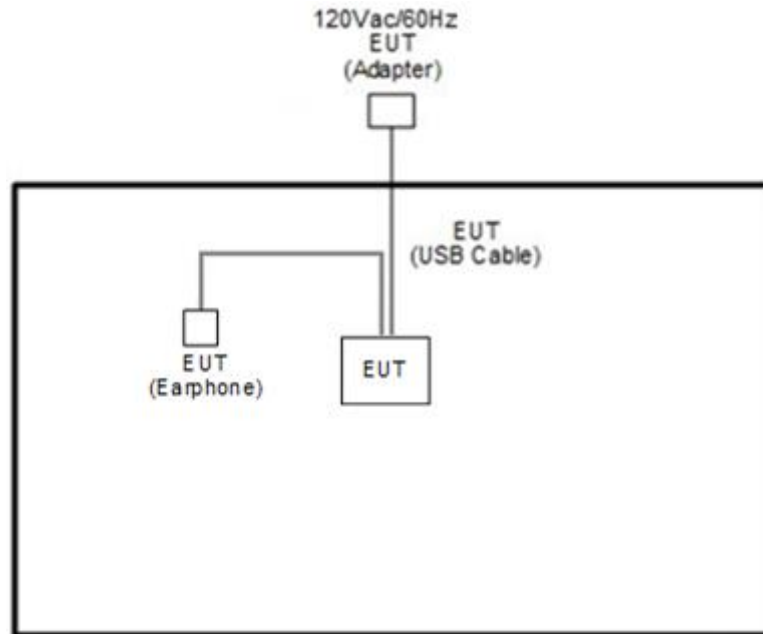

2.4 Support Unit used in test configuration and system

Item	Equipment	Brand Name	Model Name	FCC ID	Data Cable	Power Cord
1.	Base Station	Anritus	MT8821C	N/A	N/A	Unshielded, 1.8m
2.	Notebook	Lenovo	G480	QDS-BRCM1050I	N/A	Shielded cable DC O/P 1.8m, Unshielded AC I/P cable 1.8m
3.	WLAN AP	D-link	DIR-655	KA21R655B1	N/A	Unshielded, 1.8m
4.	Bluetooth Earphone	Sony	SBH82D	PY7-33726V	N/A	N/A

2.5 EUT Operation Test Setup

The RF test items, utility “FTM” was installed in Notebook which was programmed in order to make the EUT get into the engineering modes to provide channel selection, power level, data rate and the application type and for continuous transmitting signals

For AC power line conducted emissions, the EUT was set to connect with the WLAN AP under large package sizes transmission.

2.6 Measurement Results Explanation Example

For all conducted test items:

The offset level is set in the spectrum analyzer to compensate the RF cable loss and attenuator factor between EUT conducted output port and spectrum analyzer. With the offset compensation, the spectrum analyzer reading level is exactly the EUT RF output level.

Example:

The spectrum analyzer offset is derived from RF cable loss and attenuator factor.

Offset = RF cable loss + attenuator factor.

Following shows an offset computation example with cable loss 2.65 dB and 10dB attenuator.

$$\begin{aligned}
 \text{Offset(dB)} &= \text{RF cable loss(dB)} + \text{attenuator factor(dB)}. \\
 &= 2.65 + 10 = 12.65 \text{ (dB)}
 \end{aligned}$$

3 Test Result

3.1 6dB and 99% Bandwidth Measurement

3.1.1 Limit of 6dB and 99% Bandwidth

The minimum 6 dB bandwidth shall be at least 500 kHz.

3.1.2 Measuring Instruments

See list of measuring equipment of this test report.

3.1.3 Test Procedures

1. The testing follows the ANSI C63.10 Section 6.9.3 (OBW) and 11.8.1 (6dB BW).
2. The RF output of EUT was connected to the spectrum analyzer by RF cable and attenuator. The path loss was compensated to the results for each measurement.
3. Set the maximum power setting and enable the EUT to transmit continuously.
4. Make the measurement with the spectrum analyzer's resolution bandwidth (RBW) = 100 kHz. Set the Video bandwidth (VBW) = 300 kHz. In order to make an accurate measurement. The 6 dB bandwidth must be greater than 500 kHz.
5. For 99% Bandwidth Measurement, the spectrum analyzer's resolution bandwidth (RBW) is set 1-5% of the emission bandwidth and set the Video bandwidth (VBW) $\geq 3 * RBW$.
6. Measure and record the results in the test report.

3.1.4 Test Setup

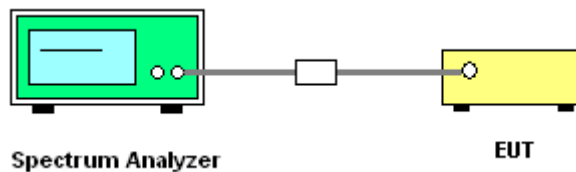

3.1.5 Test Result of 6dB and 99% Occupied Bandwidth

Please refer to Appendix A.

3.2 Output Power Measurement

3.2.1 Limit of Output Power

For systems using digital modulation in the 2400-2483.5 MHz, the limit for output power is 30 dBm. If transmitting antenna with directional gain greater than 6 dBi is used, the peak output power from the intentional radiator shall be reduced below the above stated value by the amount in dB that the directional gain of the antenna exceeds 6 dBi. In case of point-to-point operation, the limit has to be reduced by 1 dB for every 3 dB that the directional gain of the antenna exceeds 6 dBi.

3.2.2 Measuring Instruments

See list of measuring equipment of this test report.

3.2.3 Test Procedures

1. For Peak Power, the testing follows ANSI C63.10 Section 11.9.1.3 PKPM1
2. The RF output of EUT was connected to the power meter by RF cable and attenuator. The path loss was compensated to the results for each measurement.
3. Set the maximum power setting and enable the EUT to transmit continuously.
4. Measure the conducted output power and record the results in the test report.
5. For MIMO mode, calculation method follows FCC KDB 662911 D01 Multiple Transmitter Output v02r01.

3.2.4 Test Setup

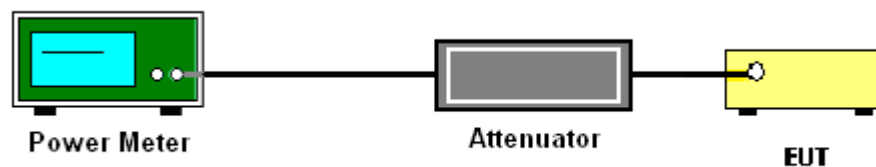



3.2.5 Test Result of Peak Output Power

2.4GHz Band																
Mod.	Data Rate	NTX	CH.	Freq. (MHz)	Peak Conducted Power (dBm)			Conducted Power Limit (dBm)		DG (dBi)		EIRP Power (dBm)		EIRP Power Limit (dBm)		Pass /Fail
					Ant6	Ant7	SUM	Ant6	Ant7	Ant6	Ant7	Ant6	Ant7	Ant6	Ant7	
11b	1Mbps	2	1	2412	16.07	14.77	18.48	30.00		2.30		20.78		36.00		Pass
11b	1Mbps	2	6	2437	16.16	14.94	18.60	30.00		2.30		20.90		36.00		Pass
11b	1Mbps	2	11	2462	16.08	14.79	18.49	30.00		2.30		20.79		36.00		Pass
11g	6Mbps	2	1	2412	18.51	17.37	20.99	30.00		2.30		23.29		36.00		Pass
11g	6Mbps	2	6	2437	18.62	17.45	21.08	30.00		2.30		23.38		36.00		Pass
11g	6Mbps	2	11	2462	18.56	17.39	21.02	30.00		2.30		23.32		36.00		Pass
HT20	MCS0	2	1	2412	18.90	17.84	21.41	30.00		2.30		23.71		36.00		Pass
HT20	MCS0	2	6	2437	18.61	17.44	21.07	30.00		2.30		23.37		36.00		Pass
HT20	MCS0	2	11	2462	18.93	17.99	21.50	30.00		2.30		23.80		36.00		Pass

Note: Measured power (dBm) has offset with cable loss.

3.3 Power Spectral Density Measurement

3.3.1 Limit of Power Spectral Density

The peak power spectral density shall not be greater than 8 dBm in any 3 kHz band at any time interval of continuous transmission.

3.3.2 Measuring Instruments

See list of measuring equipment of this test report.

3.3.3 Test Procedures

1. The testing follows the ANSI C63.10 Section 11.10.2 Method PKPSD.
2. The RF output of EUT was connected to the spectrum analyzer by RF cable and attenuator. The path loss was compensated to the results for each measurement.
3. Set the maximum power setting and enable the EUT to transmit continuously.
4. Make the measurement with the spectrum analyzer's resolution bandwidth (RBW) = 3 kHz. Video bandwidth VBW = 10 kHz In order to make an accurate measurement, set the span to 1.5 times DTS Channel Bandwidth. (6dB BW)
5. Detector = peak, Sweep time = auto couple, Trace mode = max hold, Allow trace to fully stabilize. Use the peak marker function to determine the maximum power level.
6. Measure and record the results in the test report.
7. For MIMO mode, calculation method follows F)2)f) of FCC KDB 662911 D01 Multiple Transmitter Output v02r01.

3.3.4 Test Setup

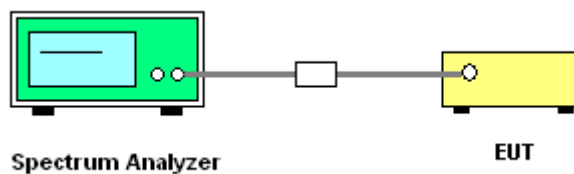

3.3.5 Test Result of Power Spectral Density

Please refer to Appendix A.

3.4 Conducted Band Edges and Spurious Emission Measurement

3.4.1 Limit of Conducted Band Edges and Spurious Emission Measurement

In any 100 kHz bandwidth outside of the authorized frequency band, the emissions which fall in the non-restricted bands shall be attenuated at least 20 dB / 30dB relative to the maximum PSD level in 100 kHz by RF conducted measurement.

3.4.2 Measuring Instruments

See list of measuring equipment of this test report.

3.4.3 Test Procedures

1. The testing follows the ANSI C63.10 Section 11.11.3 Emission level measurement.
2. The RF output of EUT was connected to the spectrum analyzer by RF cable and attenuator. The path loss was compensated to the results for each measurement.
3. Set the maximum power setting and enable the EUT to transmit continuously.
4. Set RBW = 100 kHz, VBW=300 kHz, Peak Detector. Unwanted Emissions measured in any 100 kHz bandwidth outside of the authorized frequency band shall be attenuated by at least 20 dB relative to the maximum in-band peak PSD level in 100 kHz when maximum peak conducted output power procedure is used. If the transmitter complies with the conducted power limits based on the use of RMS averaging over a time interval, the attenuation required under this paragraph shall be 30 dB instead of 20 dB per 15.247(d).
5. Measure and record the results in the test report.
6. The RF fundamental frequency should be excluded against the limit line in the operating frequency band.

3.4.4 Test Setup

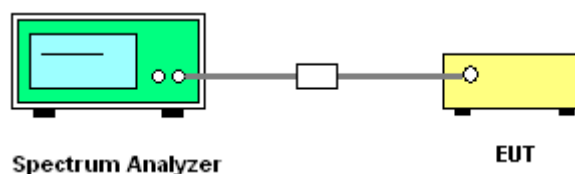

3.4.5 Test Result of Conducted Band Edges and Spurious Emission

Please refer to Appendix A.



3.5 Radiated Band Edges and Spurious Emission Measurement

3.5.1 Limit of Radiated band edge and Spurious Emission Measurement

In any 100 kHz bandwidth outside the intentional radiator frequency band, all harmonics/spurious must be at least 20 dB below the highest emission level within the authorized band. If the output power of this device was measured by spectrum analyzer, the attenuation under this paragraph shall be 30 dB instead of 20 dB. In addition, radiated emissions which fall in the restricted bands must also comply with the limits as below.

Frequency (MHz)	Field Strength (microvolts/meter)	Measurement Distance (meters)
0.009 – 0.490	2400/F(kHz)	300
0.490 – 1.705	24000/F(kHz)	30
1.705 – 30.0	30	30
30 – 88	100	3
88 – 216	150	3
216 - 960	200	3
Above 960	500	3

3.5.2 Measuring Instruments

See list of measuring equipment of this test report.



3.5.3 Test Procedures

1. The testing follows the ANSI C63.10 Section 11.12.1 Radiated emission measurements.
2. The EUT was arranged to its worst case and then tune the antenna tower (from 1 m to 4 m) and turntable (from 0 degree to 360 degrees) to find the maximum reading. A pre-amp and a high pass filter are used for the test in order to get better signal level.
3. The EUT was placed on a turntable with 0.8 meter for frequency below 1 GHz and 1.5 meter for frequency above 1 GHz respectively above ground.
4. The EUT was set 3 meters from the interference receiving antenna, which was mounted on the top of a variable height antenna tower.
5. Corrected Reading: Antenna Factor + Cable Loss + Read Level - Preamp Factor = Level
6. For testing below 1 GHz, if the emission level of the EUT in peak mode was 3 dB lower than the limit specified, then peak values of EUT will be reported, otherwise, the emissions will be repeated one by one using the CISPR quasi-peak method and reported.
7. For testing above 1 GHz, the emission level of the EUT in peak mode was 20 dB lower than average limit (that means the emission level in average mode also complies with the limit in average mode), then peak values of EUT will be reported, otherwise, the emissions will be measured in average mode again and reported.
8. Use the following spectrum analyzer settings:
 - (1) Span shall wide enough to fully capture the emission being measured;
 - (2) Set RBW = 100 kHz for $f < 1$ GHz; VBW \geq RBW; Sweep = auto; Detector function = peak; Trace = max hold;
 - (3) Set RBW = 1 MHz, VBW= 3 MHz for $f \geq 1$ GHz for peak measurement.
For average measurement:
 - VBW = 10 Hz, when duty cycle is no less than 98 percent.
 - VBW $\geq 1/T$, when duty cycle is less than 98 percent where T is the minimum transmission duration over which the transmitter is on and is transmitting at its maximum power control level for the tested mode of operation.

3.5.4 Test Setup

For radiated emissions below 30MHz

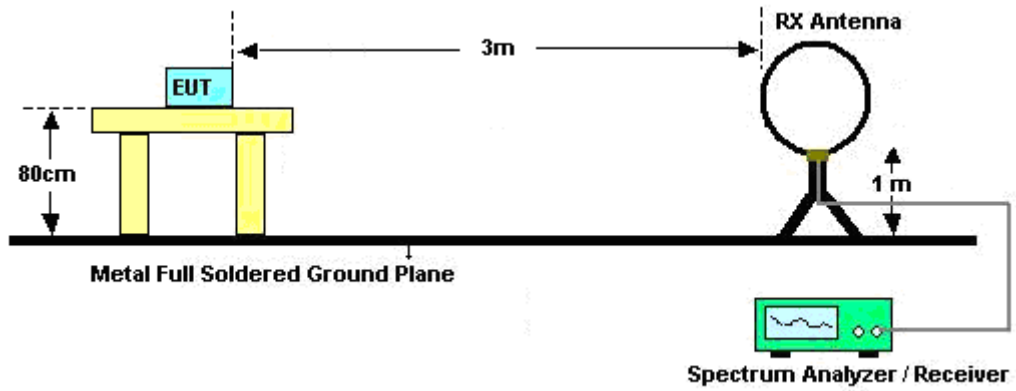

For radiated emissions from 30MHz to 1GHz

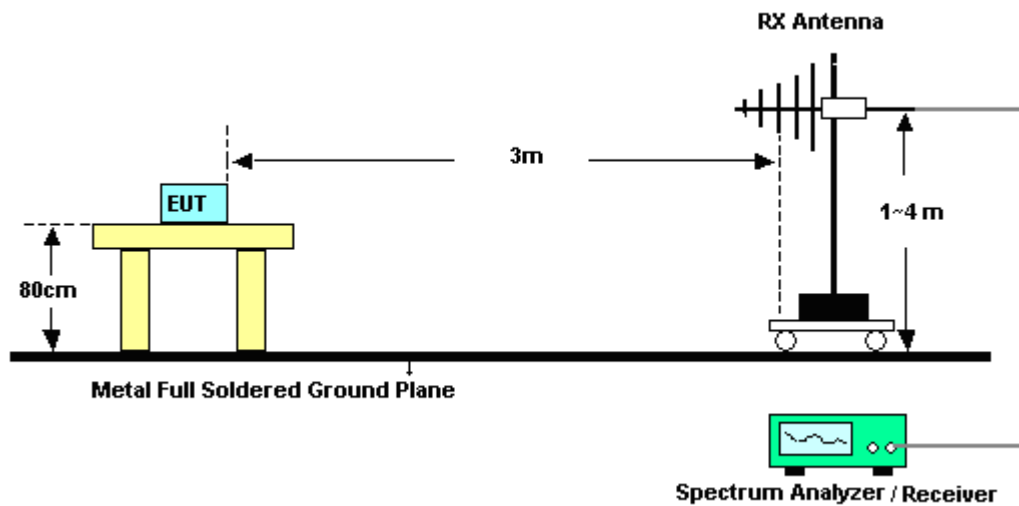

For radiated test from 1GHz to 18GHz

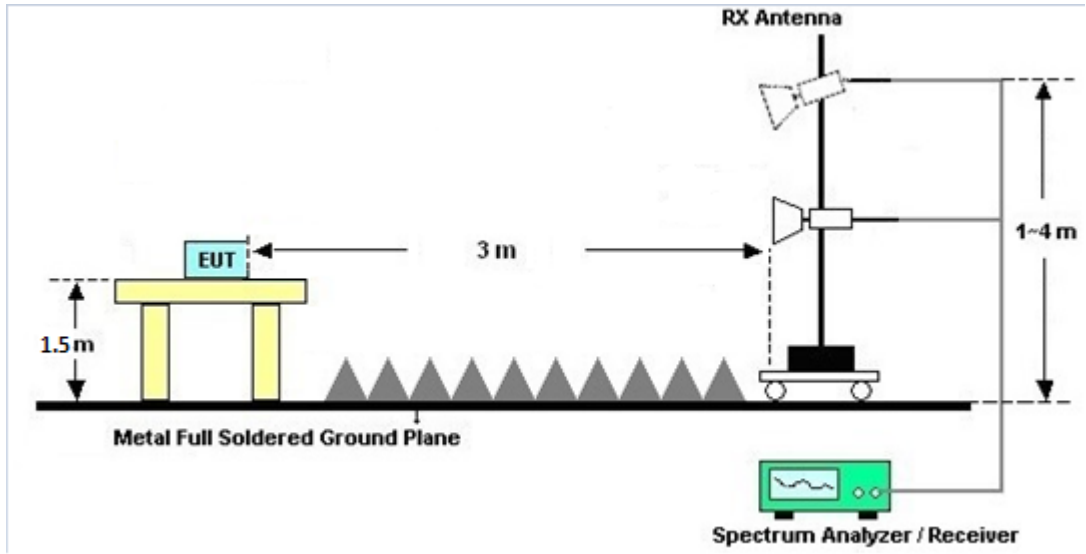

For radiated test above 18GHz

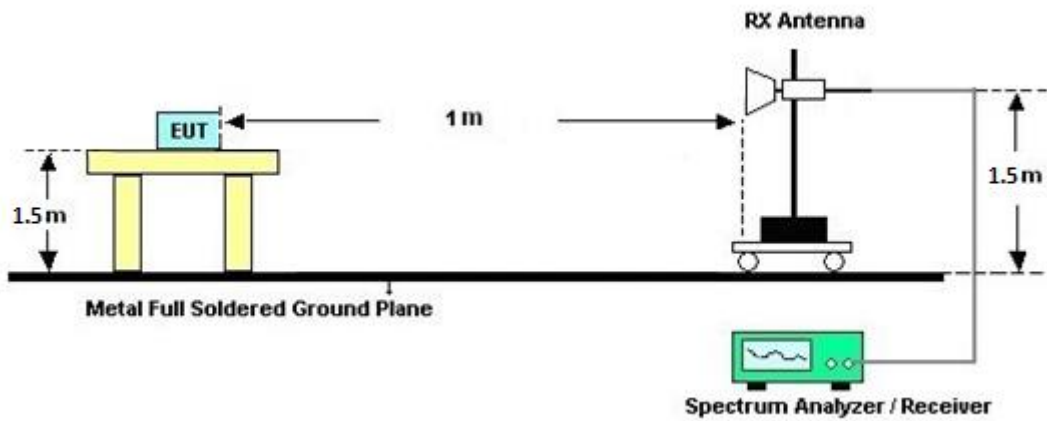



3.5.5 Test Results of Radiated Spurious Emissions (9kHz ~ 30MHz)

The low frequency, which started from 9 kHz to 30MHz, was pre-scanned and the result which was 20dB lower than the limit line was not reported.

There is adequate comparison measurement of both open-field test site and alternative test site - semi-Anechoic chamber according to 414788 D01 Radiated Test Site v01r01, and the result came out very similar.

3.5.6 Test Result of Radiated Spurious at Band Edges

Please refer to Appendix C and D.

3.5.7 Duty Cycle

Please refer to Appendix E.

3.5.8 Test Result of Radiated Spurious Emission (30MHz ~ 10th Harmonic)

Please refer to Appendix C and D.

3.6 AC Conducted Emission Measurement

3.6.1 Limit of AC Conducted Emission

For equipment that is designed to be connected to the public utility (AC) power line, the radio frequency voltage that is conducted back onto the AC power line on any frequency or frequencies within the band 150 kHz to 30 MHz shall not exceed the limits in the following table.

Frequency of Emission (MHz)	Conducted Limit (dB μ V)	
	Quasi-Peak	Average
0.15-0.5	66 to 56*	56 to 46*
0.5-5	56	46
5-30	60	50

*Decreases with the logarithm of the frequency.

3.6.2 Measuring Instruments

See list of measuring equipment of this test report.

3.6.3 Test Procedures

1. The EUT was placed 0.4 meter from the conducting wall of the shielding room, and it was kept at least 80 centimeters from any other grounded conducting surface.
2. Connect EUT to the power mains through a line impedance stabilization network (LISN).
3. All the support units are connecting to the other LISN.
4. The LISN provides 50 ohm coupling impedance for the measuring instrument.
5. The FCC states that a 50 ohm, 50 microhenry LISN shall be used.
6. Both sides of AC line were checked for maximum conducted interference.
7. The frequency range from 150 kHz to 30 MHz was searched.
8. Set the test-receiver system to Peak Detect Function and specified bandwidth (IF bandwidth = 9kHz) with Maximum Hold Mode.

3.6.4 Test Setup

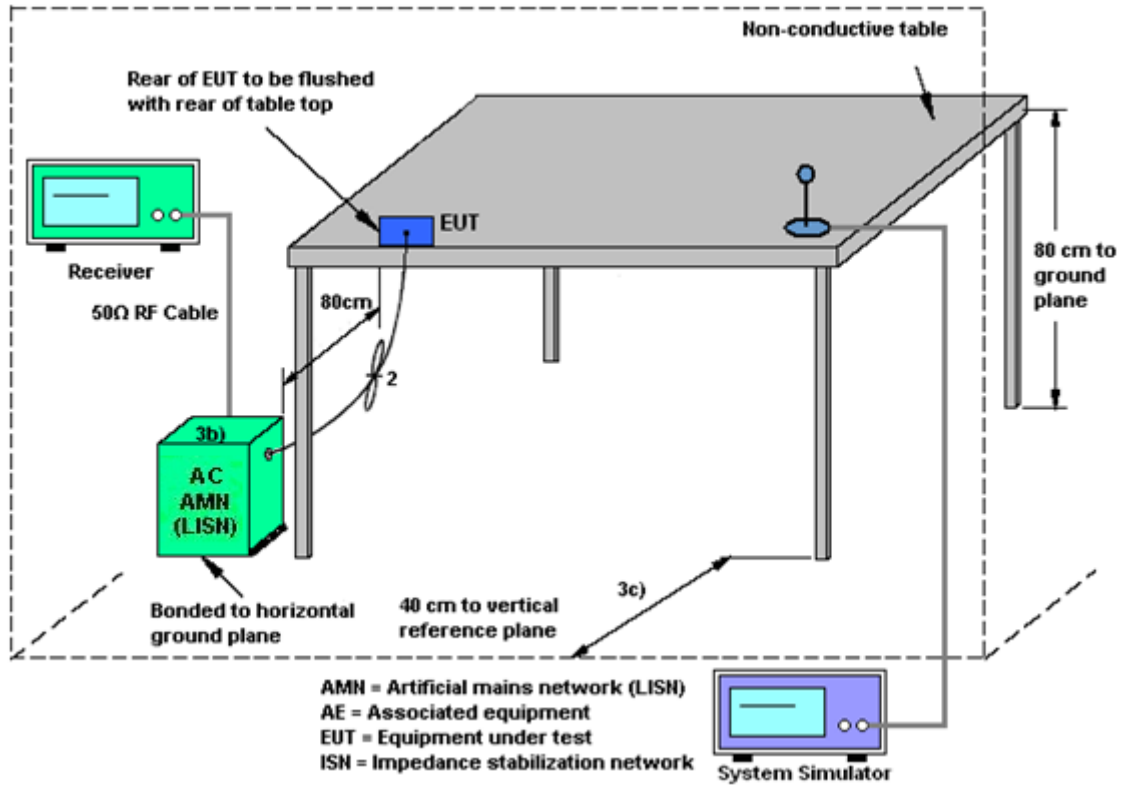

3.6.5 Test Result of AC Conducted Emission

Please refer to Appendix B.



3.7 Antenna Requirements

3.7.1 Standard Applicable

If directional gain of transmitting Antennas is greater than 6 dBi, the power shall be reduced by the same level in dB comparing to gain minus 6 dBi. The use of a permanently attached antenna or of an antenna that uses a unique coupling to the intentional radiator shall be considered sufficient to comply with the rule.

3.7.2 Antenna Anti-Replacement Construction

An embedded-in antenna design is used.

3.7.3 Antenna Gain

<CDD Modes >

FCC KDB 662911 D01 Multiple Transmitter Output v02r01

For CDD transmissions, directional gain is calculated as

Directional gain = G_{ANT} + Array Gain, where Array Gain is as follows.

For power spectral density (PSD) measurements on all devices,

Array Gain = 10 log(N_{ANT}/N_{SS}=1) dB.

For power measurements on IEEE 802.11 devices,

Array Gain = 0 dB (i.e., no array gain) for N_{ANT} ≤ 4.

Directional gain may be calculated by using the formulas applicable to equal gain antennas with G_{ANT} set equal to the gain of the antenna having the highest gain;

The EUT supports CDD mode.

For power, the directional gain G_{ANT} is set equal to the antenna having the highest gain, i.e., F)2)f)i).

For PSD, the directional gain calculation is following F)2)f)ii) of KDB 662911 D01 v02r01.

The power and PSD limit should be modified if the directional gain of EUT is over 6 dBi,

The directional gain "DG" is calculated as following table.

<CDD Modes>						
			DG for Power (dBi)	DG for PSD (dBi)	Power Limit Reduction (dB)	PSD Limit Reduction (dB)
	Ant. 6 (dBi)	Ant. 7 (dBi)				
2.4 GHz	2.30	-2.60	2.30	3.20	0.00	0.00

Power Limit Reduction = DG(Power) – 6dBi, (min = 0)

PSD Limit Reduction = DG(PSD) – 6dBi, (min = 0)



4 List of Measuring Equipment

Instrument	Manufacturer	Model No.	Serial No.	Characteristics	Calibration Date	Test Date	Due Date	Remark
Spectrum Analyzer	R&S	FSV40	101040	10Hz~40GHz	Oct. 14, 2021	Jan. 19, 2022~ Feb. 18, 2022	Oct. 13, 2022	Conducted (TH01-KS)
Pulse Power Sensor	Anritsu	MA2411B	0917070	300MHz~40GHz	Jan. 05, 2022	Jan. 19, 2022~ Feb. 18, 2022	Jan. 04, 2023	Conducted (TH01-KS)
Power Meter	Anritsu	ML2495A	1005002	50MHz Bandwidth	Jan. 05, 2022	Jan. 19, 2022~ Feb. 18, 2022	Jan. 04, 2023	Conducted (TH01-KS)
EMI Test Receiver	Keysight	N9038A	MY564000 04	3Hz~8.5GHz;Max 30dBm	Oct. 16, 2021	Jan. 28, 2022	Oct. 15, 2022	Radiation (03CH06-KS)
EXA Spectrum Analyzer	Keysight	N9010A	MY551502 08	10Hz-44GHz	Apr. 12, 2021	Jan. 28, 2022	Apr. 11, 2022	Radiation (03CH06-KS)
Loop Antenna	R&S	HFH2-Z2	100321	9kHz~30MHz	Oct. 30, 2021	Jan. 28, 2022	Oct. 29, 2022	Radiation (03CH06-KS)
Bilog Antenna	TeseQ	CBL6111D	49921	30MHz-1GHz	May 27, 2021	Jan. 28, 2022	May 26, 2022	Radiation (03CH06-KS)
Double Ridge Horn Antenna	ETS-Lindgren	3117	00218652	1GHz~18GHz	Apr. 25, 2021	Jan. 28, 2022	Apr. 24, 2022	Radiation (03CH06-KS)
SHF-EHF Horn	Com-power	AH-840	101093	18GHz~40GHz	Jan. 05, 2022	Jan. 28, 2022	Jan. 04, 2023	Radiation (03CH06-KS)
Amplifier	SONOMA	310N	187289	9KHz ~1GHZ	Apr. 12, 2021	Jan. 28, 2022	Apr. 11, 2022	Radiation (03CH06-KS)
Amplifier	MITEQ	EM18G40GG A	060728	18~40GHz	Jan. 05, 2022	Jan. 28, 2022	Jan. 04, 2023	Radiation (03CH06-KS)
high gain Amplifier	MITEQ	AMF-7D-0010 1800-30-10P	2025788	1Ghz-18Ghz	Jul. 30, 2021	Jan. 28, 2022	Jul. 29, 2022	Radiation (03CH06-KS)
Amplifier	Keysight	83017A	MY532702 03	500MHz~26.5GHz	Apr. 13, 2021	Jan. 28, 2022	Apr. 12, 2022	Radiation (03CH06-KS)
AC Power Source	Chroma	61601	F1040900 04	N/A	NCR	Jan. 28, 2022	NCR	Radiation (03CH06-KS)
EMI Receiver	R&S	ESCI7	100768	9kHz~7GHz;	Apr. 21, 2021	Dec. 20, 2021	Apr. 20, 2022	Conduction (CO01-KS)
AC LISN (for auxiliary equipment)	MessTec	AN3016	060103	9kHz~30MHz	Oct. 14, 2021	Dec. 20, 2021	Oct. 13, 2022	Conduction (CO01-KS)
AC LISN	R&S	ENV216	100334	9kHz~30MHz	Oct. 14, 2021	Dec. 20, 2021	Oct. 13, 2022	Conduction (CO01-KS)
AC Power Source	Chroma	61602	ABP00000 0811	AC 0V~300V, 45Hz~1000Hz	Oct. 14, 2021	Dec. 20, 2021	Oct. 13, 2022	Conduction (CO01-KS)

NCR: No Calibration Required



5 Uncertainty of Evaluation

Uncertainty of Conducted Emission Measurement (150 kHz ~ 30 MHz)

Measuring Uncertainty for a Level of Confidence of 95% ($U = 2Uc(y)$)	2.94dB
---	--------

Uncertainty of Radiated Emission Measurement (30 MHz ~ 1000 MHz)

Measuring Uncertainty for a Level of Confidence of 95% ($U = 2Uc(y)$)	5.0dB
---	-------

Uncertainty of Radiated Emission Measurement (1000 MHz ~ 18000 MHz)

Measuring Uncertainty for a Level of Confidence of 95% ($U = 2Uc(y)$)	5.0dB
---	-------

Uncertainty of Radiated Emission Measurement (18000 MHz ~ 40000 MHz)

Measuring Uncertainty for a Level of Confidence of 95% ($U = 2Uc(y)$)	5.0dB
---	-------



Appendix A. Conducted Test Results



Ambient Condition: 25 °C, 45 % RH
Test Date: 2022.1.19 ~ 2022. 2.18
Test Engineer: Jack Fan

6dB Bandwidth

Test Result

TestMode	Antenna	Frequency[MHz]	6dB BW [MHz]	FL[MHz]	FH[MHz]	Limit[MHz]	Verdict
11B-CDD	Ant6	2412	8.08	2407.96	2416.04	0.5	PASS
	Ant7	2412	8.08	2407.96	2416.04	0.5	PASS
	Ant6	2437	8.04	2433.00	2441.04	0.5	PASS
	Ant7	2437	8.08	2432.96	2441.04	0.5	PASS
	Ant6	2462	8.08	2457.96	2466.04	0.5	PASS
	Ant7	2462	8.08	2457.96	2466.04	0.5	PASS
11G-CDD	Ant6	2412	15.08	2404.48	2419.56	0.5	PASS
	Ant7	2412	15.92	2404.24	2420.16	0.5	PASS
	Ant6	2437	15.44	2429.44	2444.88	0.5	PASS
	Ant7	2437	16.04	2428.84	2444.88	0.5	PASS
	Ant6	2462	16.32	2453.84	2470.16	0.5	PASS
	Ant7	2462	15.64	2454.24	2469.88	0.5	PASS
11N20CDD	Ant6	2412	15.96	2403.60	2419.56	0.5	PASS
	Ant7	2412	16.56	2403.60	2420.16	0.5	PASS
	Ant6	2437	15.96	2429.44	2445.40	0.5	PASS
	Ant7	2437	16.84	2428.52	2445.36	0.5	PASS
	Ant6	2462	16.80	2453.60	2470.40	0.5	PASS
	Ant7	2462	15.16	2454.40	2469.56	0.5	PASS



Test Graphs

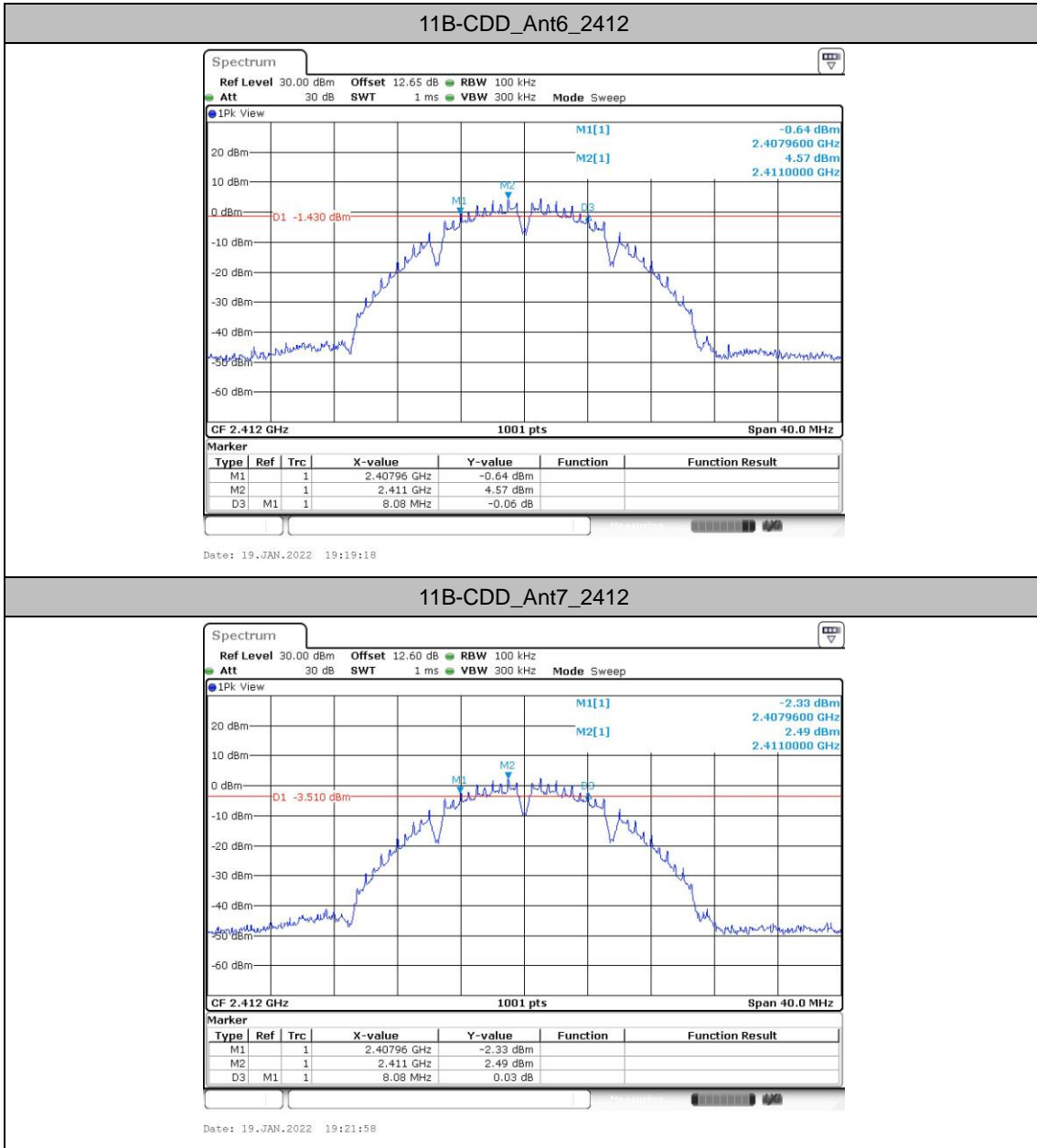



11B-CDD_Ant6_2437

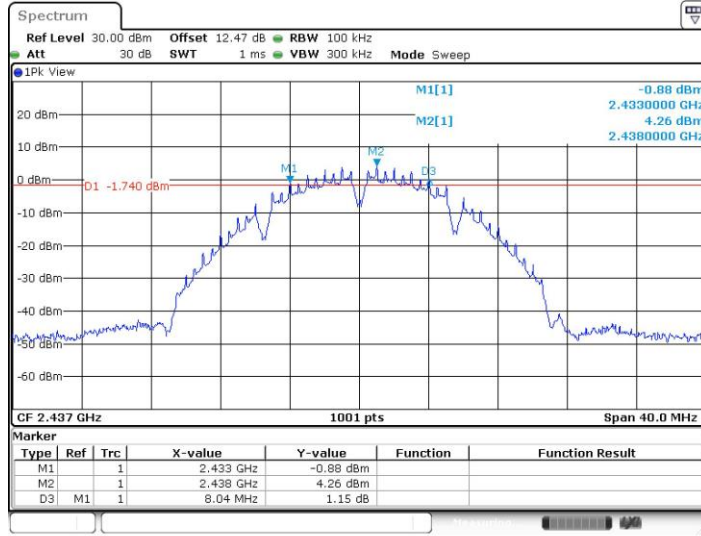

Date: 19.JAN.2022 19:25:38

11B-CDD_Ant7_2437

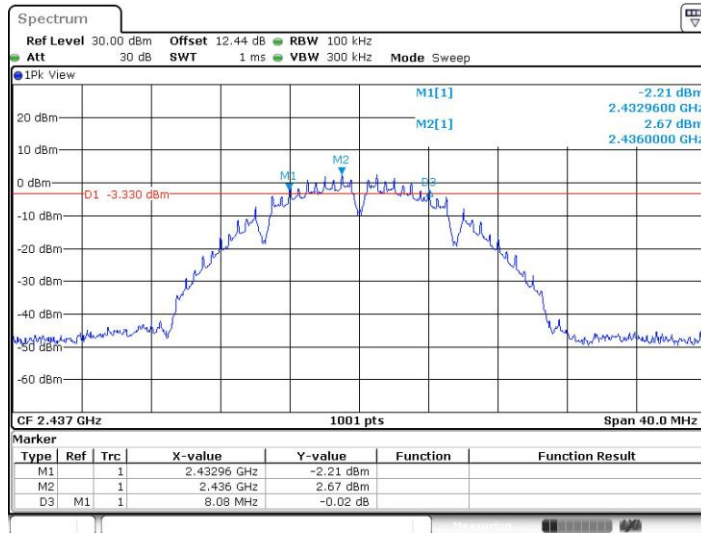

Date: 19.JAN.2022 19:27:57



11B-CDD_Ant6_2462

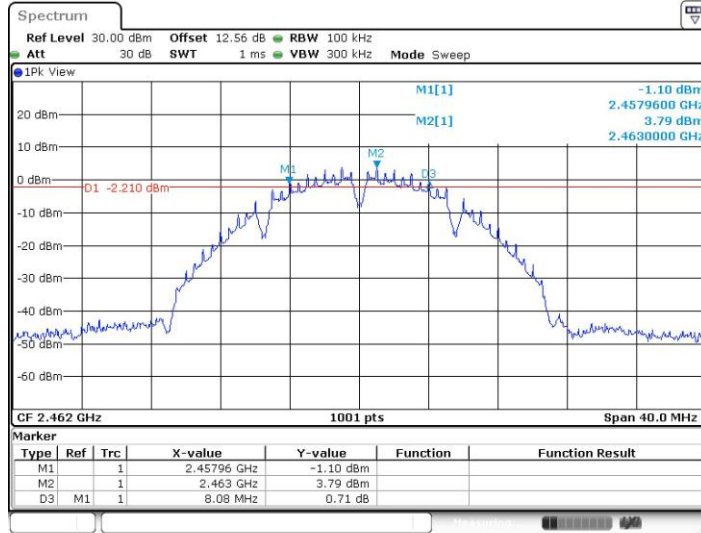

11B-CDD_Ant7_2462

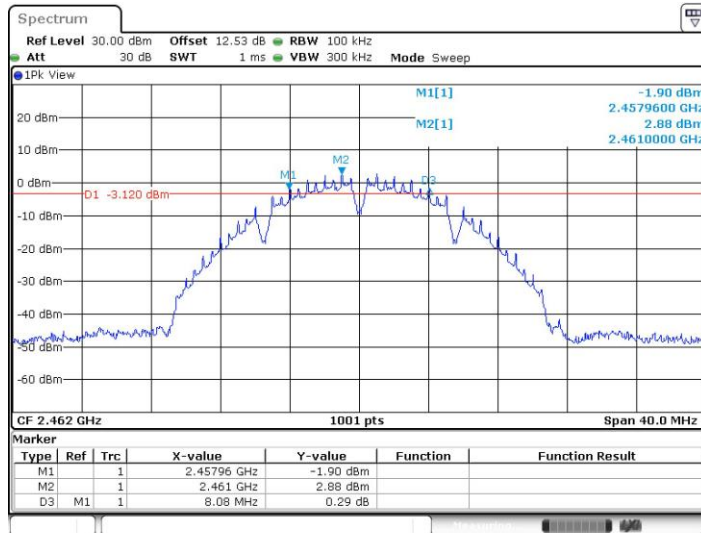



11G-CDD_Ant6_2412

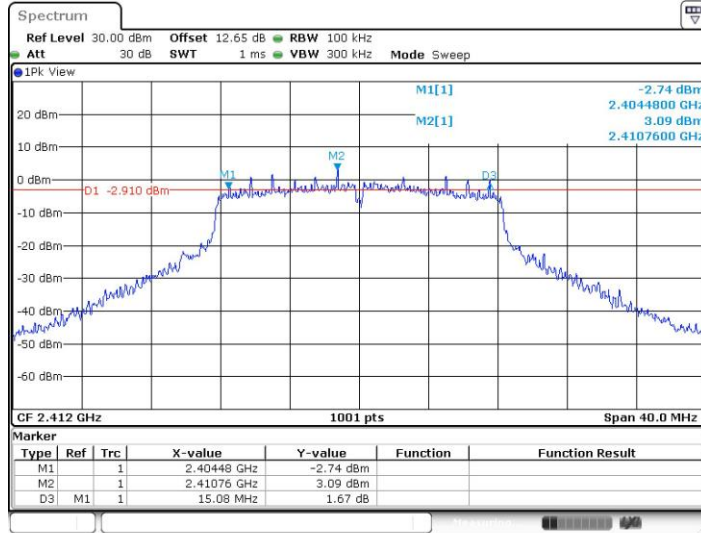

Date: 19.JAN.2022 19:36:59

11G-CDD_Ant7_2412

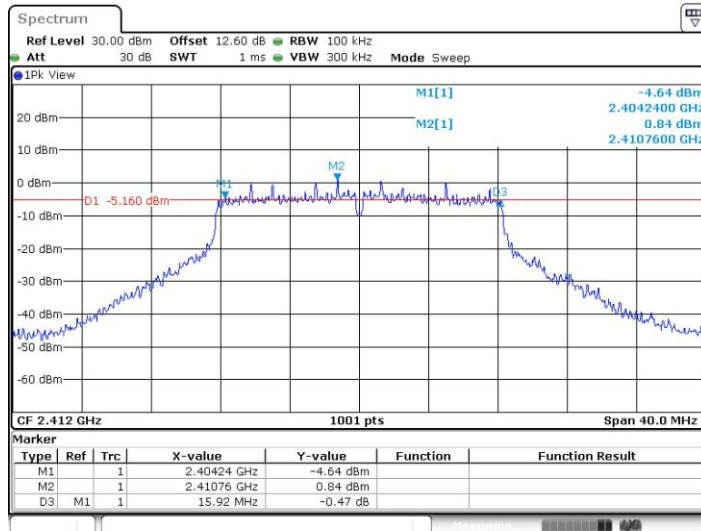

Date: 19.JAN.2022 19:39:15



11G-CDD_Ant6_2437

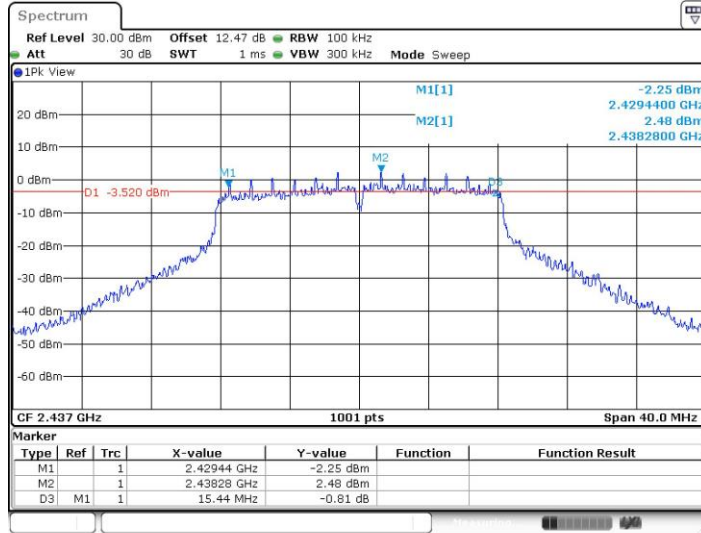

Date: 19.JAN.2022 19:41:37

11G-CDD_Ant7_2437

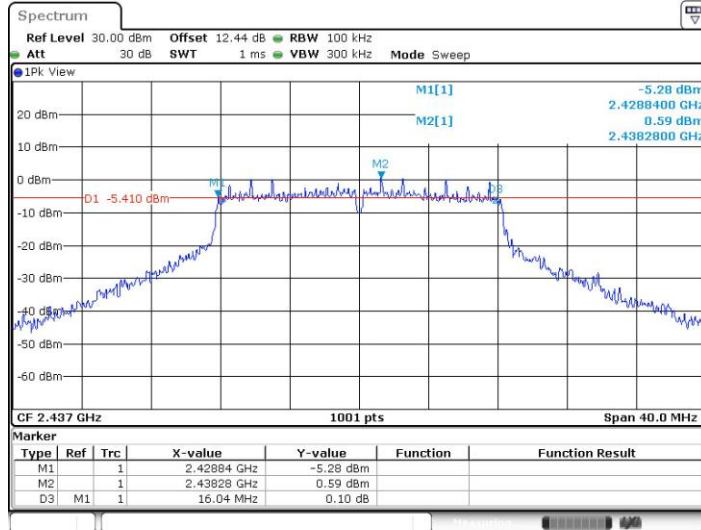

Date: 19.JAN.2022 19:43:24



11G-CDD_Ant6_2462

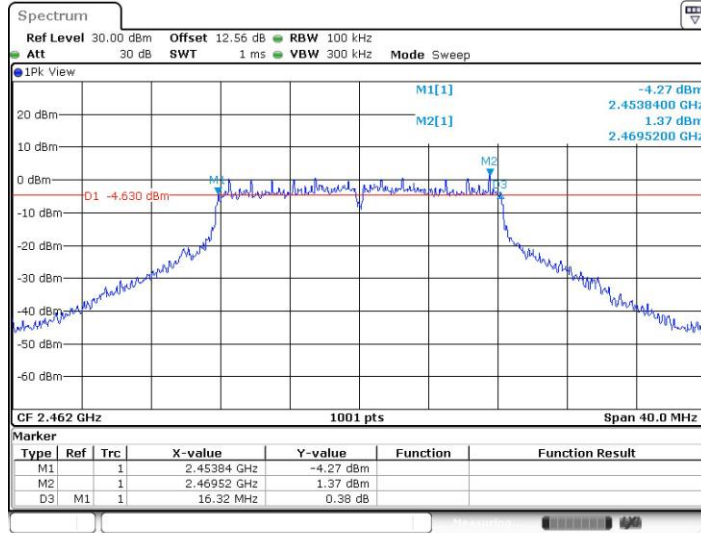

Date: 19.JAN.2022 19:49:05

11G-CDD_Ant7_2462

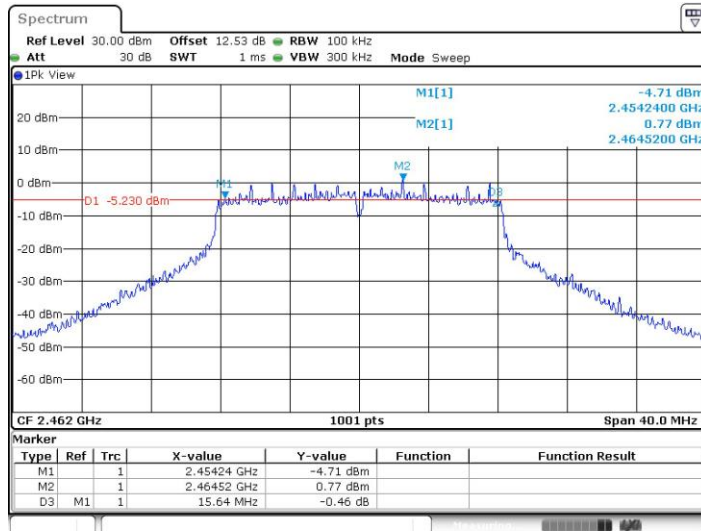

Date: 19.JAN.2022 19:51:12



11N20CDD_Ant6_2412

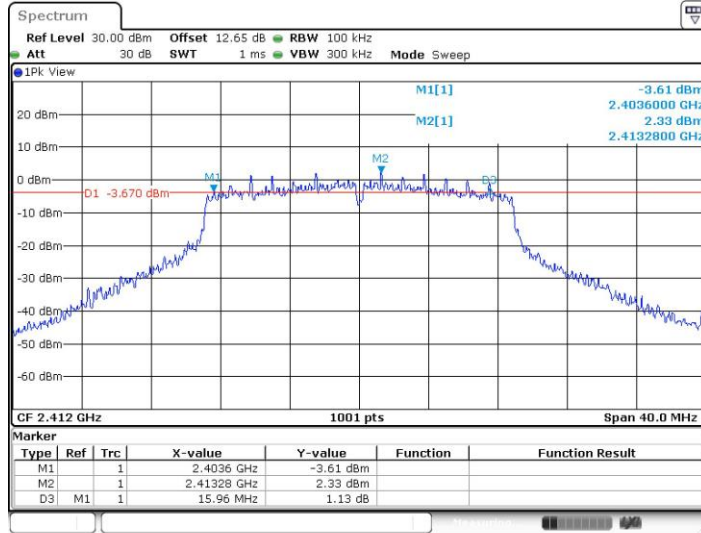

Date: 19.JAN.2022 19:54:51

11N20CDD_Ant7_2412

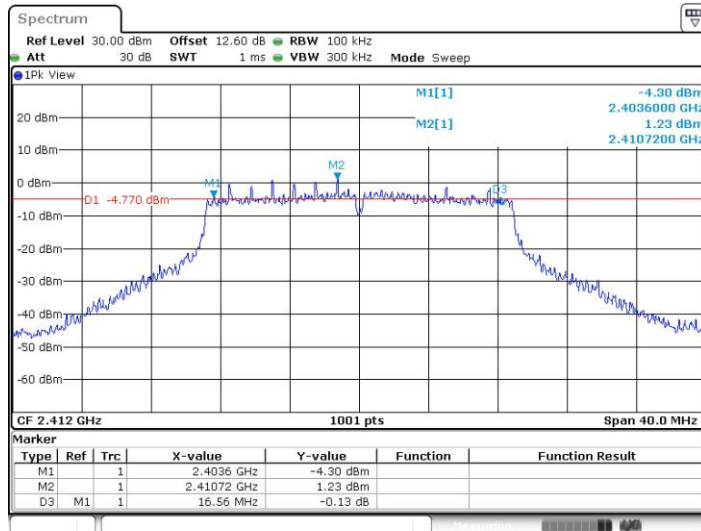

Date: 19.JAN.2022 19:56:58



11N20CDD_Ant6_2437

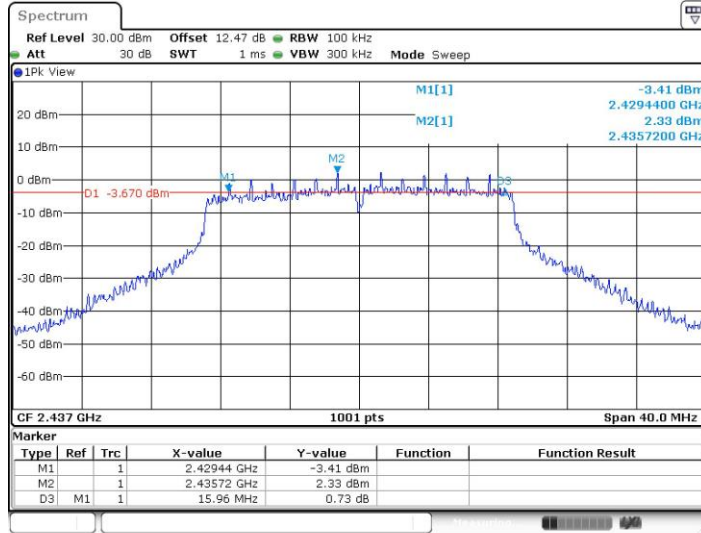

11N20CDD_Ant7_2437

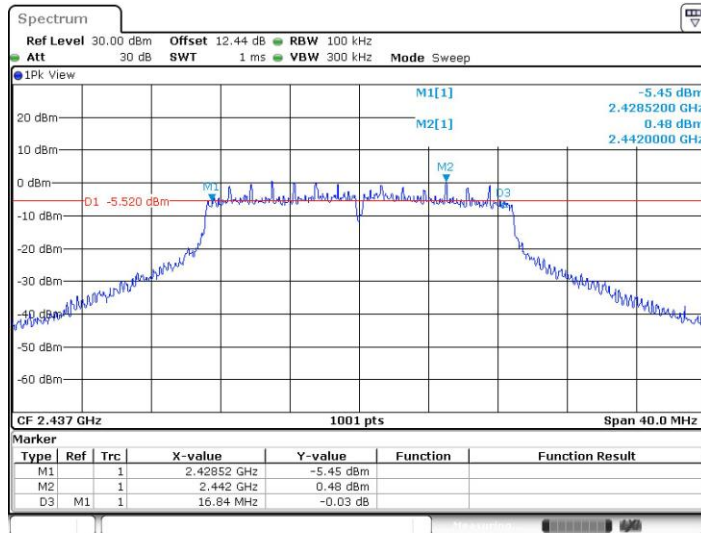



11N20CDD_Ant6_2462

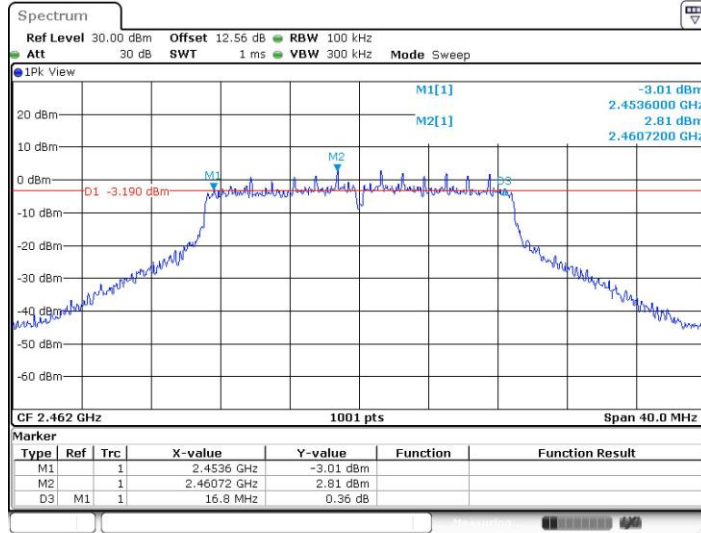

Date: 19.JAN.2022 20:08:26

11N20CDD_Ant7_2462

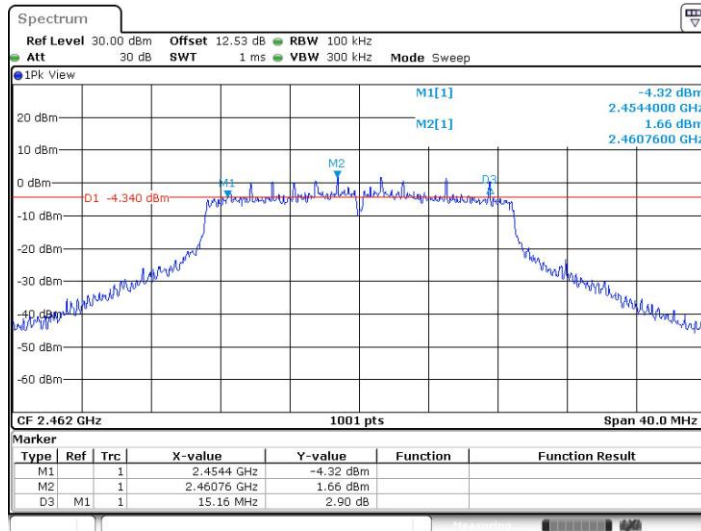

Date: 19.JAN.2022 20:10:33



Occupied Channel Bandwidth

Test Result

TestMode	Antenna	Channel Frequency[MHz]	OCB [MHz]	FL[MHz]	FH[MHz]	Limit[MHz]	Verdict
11B-CDD	Ant6	2412	13.427	2405.247	2418.673	---	---
	Ant7	2412	13.946	2405.087	2419.033	---	---
	Ant6	2437	13.746	2430.367	2444.113	---	---
	Ant7	2437	13.986	2429.967	2443.953	---	---
	Ant6	2462	14.066	2455.047	2469.113	---	---
	Ant7	2462	13.946	2455.047	2468.993	---	---
11G-CDD	Ant6	2412	16.943	2403.489	2420.432	---	---
	Ant7	2412	16.943	2403.528	2420.472	---	---
	Ant6	2437	17.143	2428.568	2445.711	---	---
	Ant7	2437	16.983	2428.489	2445.472	---	---
	Ant6	2462	17.223	2453.409	2470.631	---	---
	Ant7	2462	16.823	2453.568	2470.392	---	---
11N20CDD	Ant6	2412	18.062	2402.969	2421.031	---	---
	Ant7	2412	18.182	2402.929	2421.111	---	---
	Ant6	2437	18.262	2428.049	2446.311	---	---
	Ant7	2437	18.222	2427.889	2446.111	---	---
	Ant6	2462	18.422	2452.849	2471.271	---	---
	Ant7	2462	18.142	2452.969	2471.111	---	---

Note: The occupied channel bandwidth is maintained within the band of operation for all of the modulations.

modulations.



Test Graphs

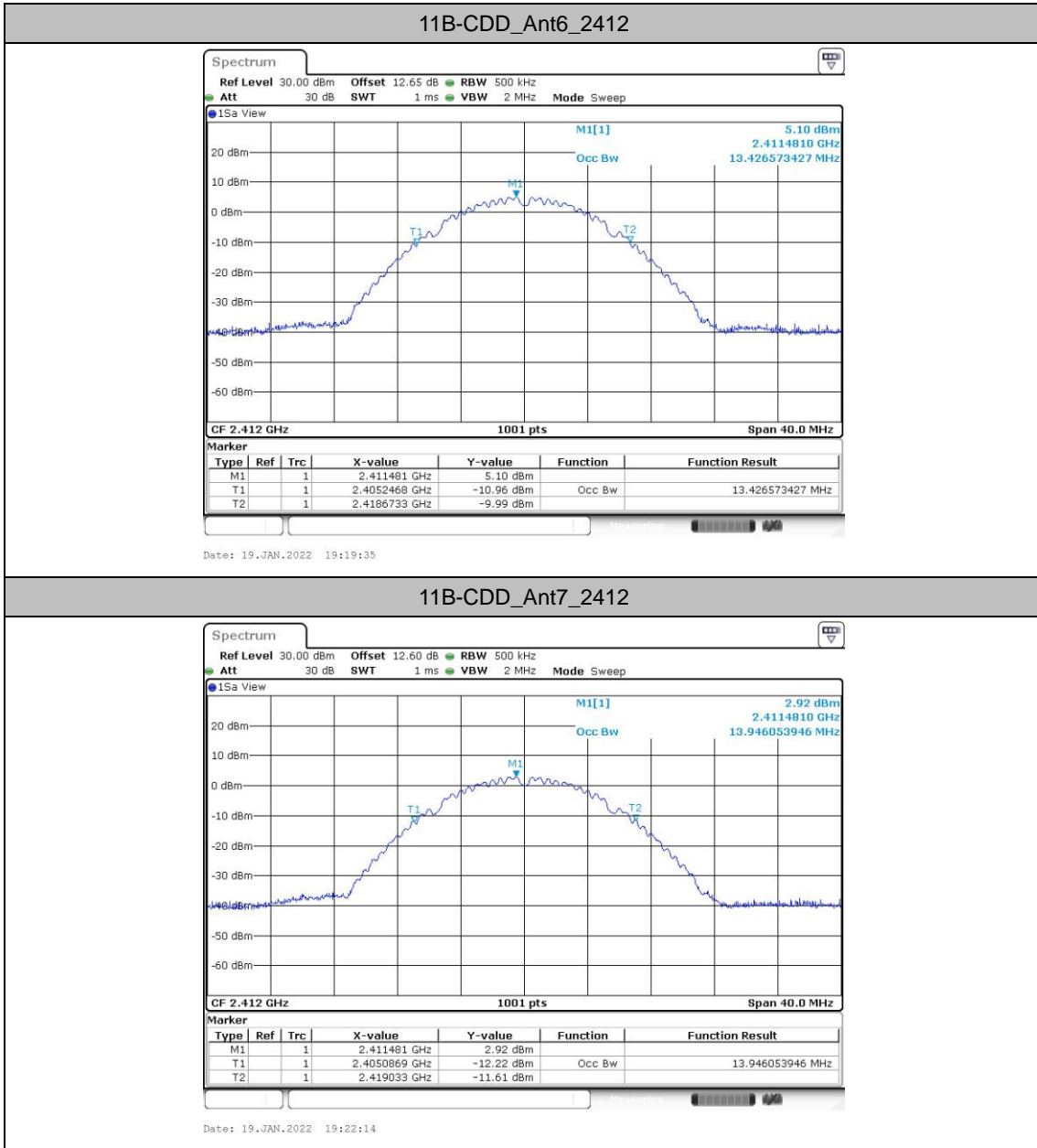



11B-CDD_Ant6_2437

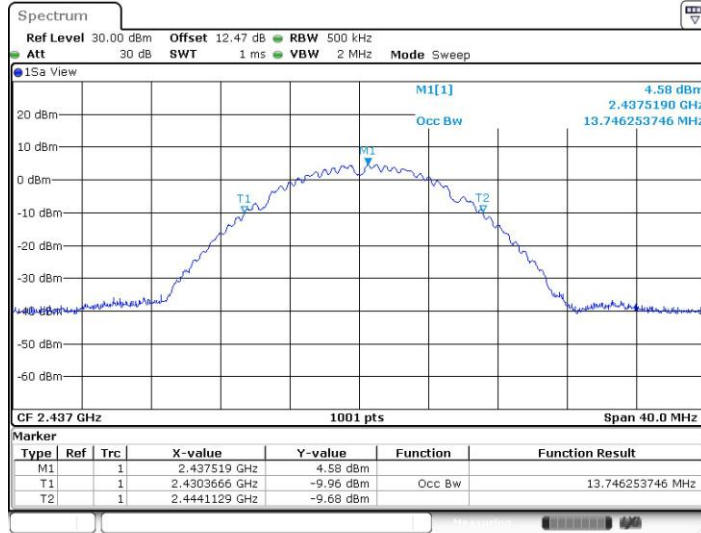

Date: 19.JAN.2022 19:25:53

11B-CDD_Ant7_2437

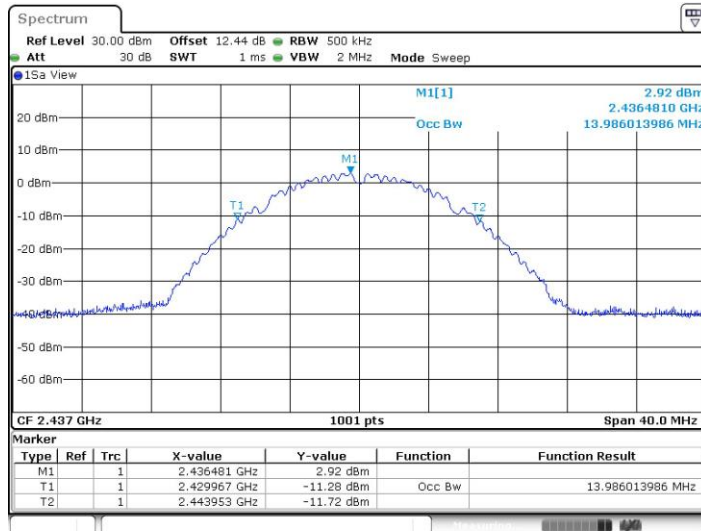

Date: 19.JAN.2022 19:28:13



11B-CDD_Ant6_2462

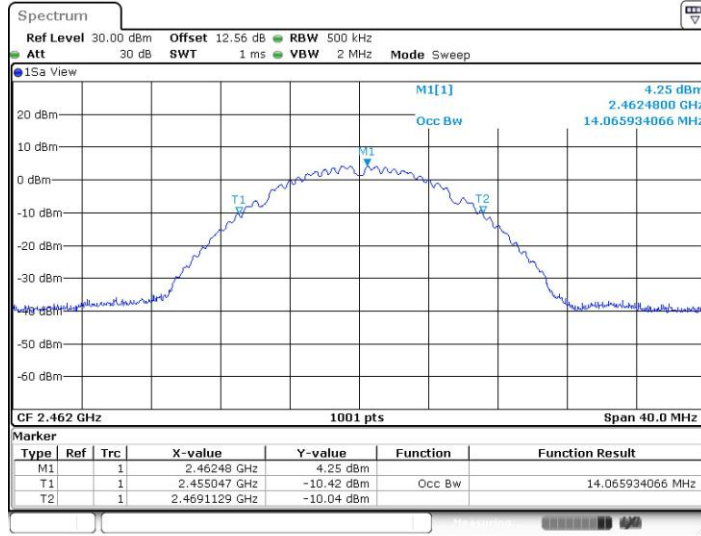

Date: 19.JAN.2022 19:31:09

11B-CDD_Ant7_2462

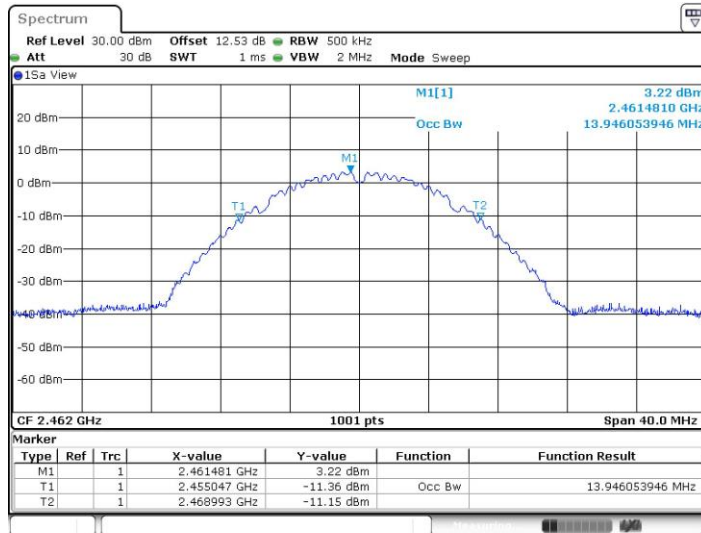

Date: 19.JAN.2022 19:33:51



11G-CDD_Ant6_2412

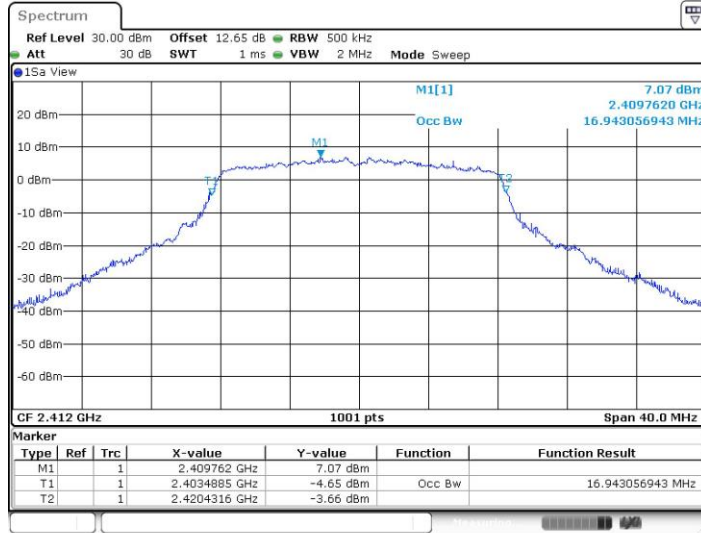

Date: 19.JAN.2022 19:37:15

11G-CDD_Ant7_2412

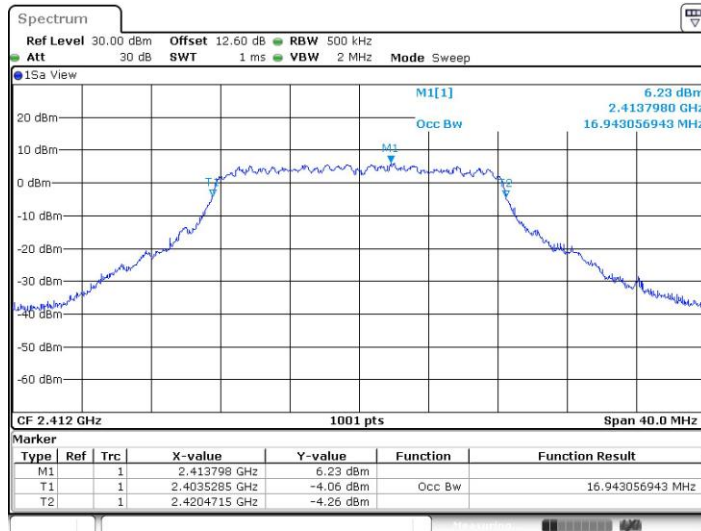

Date: 19.JAN.2022 19:39:28



11G-CDD_Ant6_2437

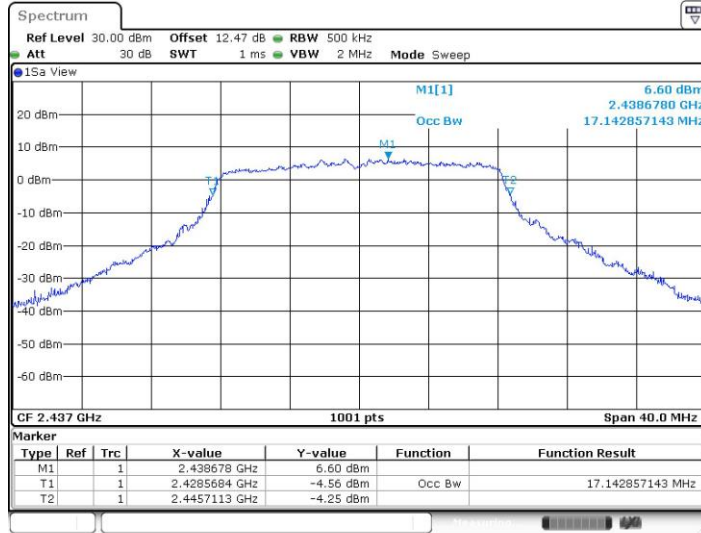

Date: 19.JAN.2022 19:41:48

11G-CDD_Ant7_2437

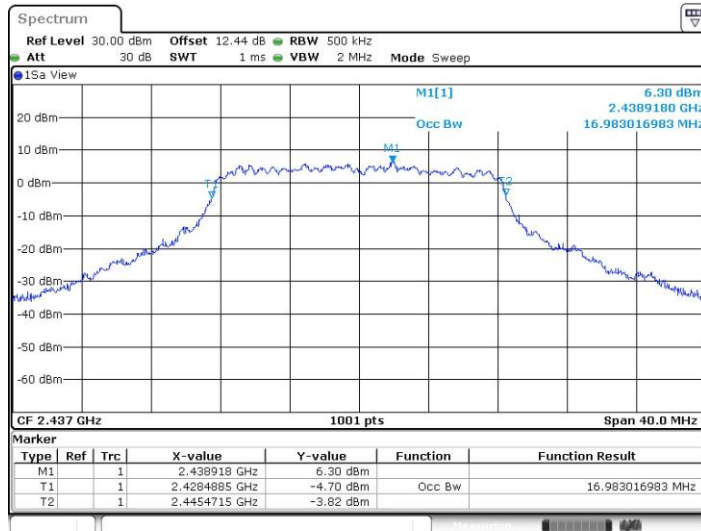

Date: 19.JAN.2022 19:43:37



11G-CDD_Ant6_2462

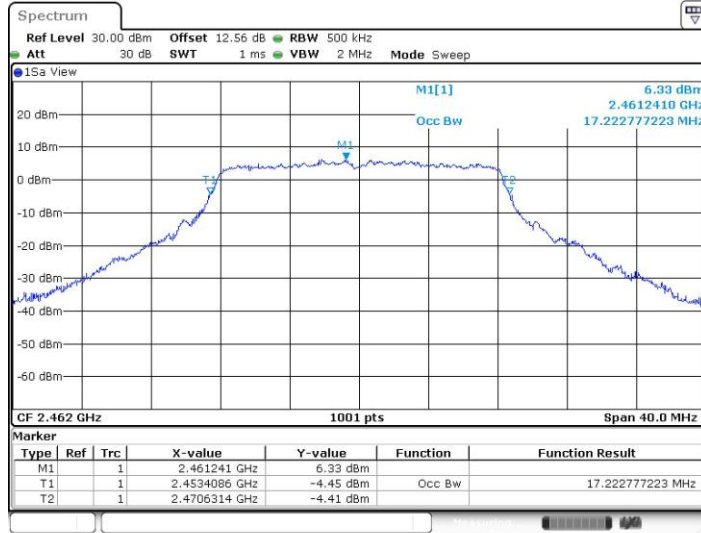

Date: 19.JAN.2022 19:49:18

11G-CDD_Ant7_2462

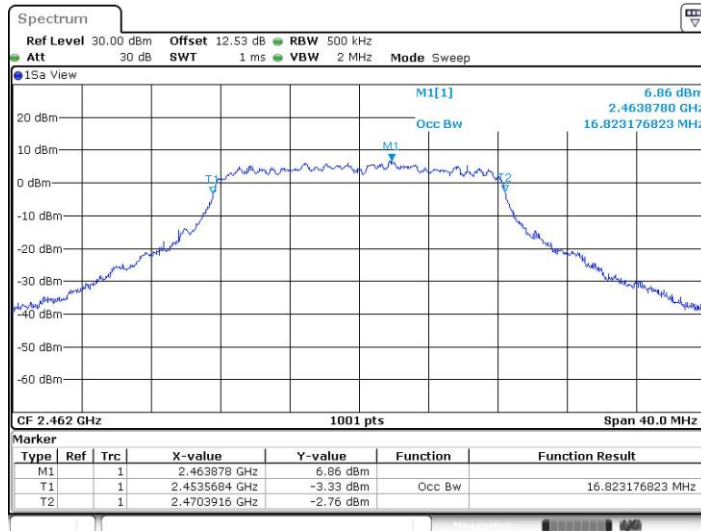

Date: 19.JAN.2022 19:51:26



11N20CDD_Ant6_2412

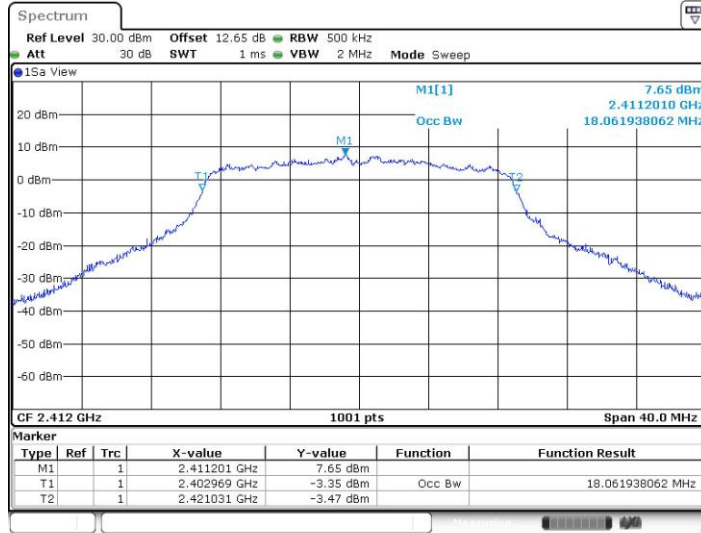

Date: 19.JAN.2022 19:55:04

11N20CDD_Ant7_2412

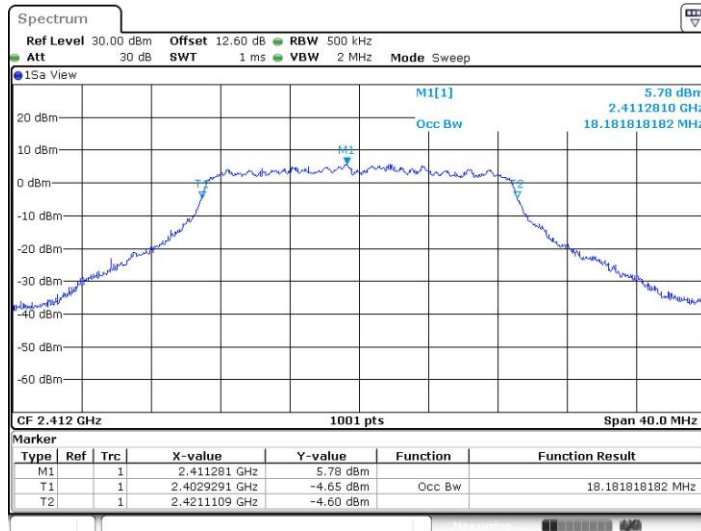

Date: 19.JAN.2022 19:57:11



11N20CDD_Ant6_2437

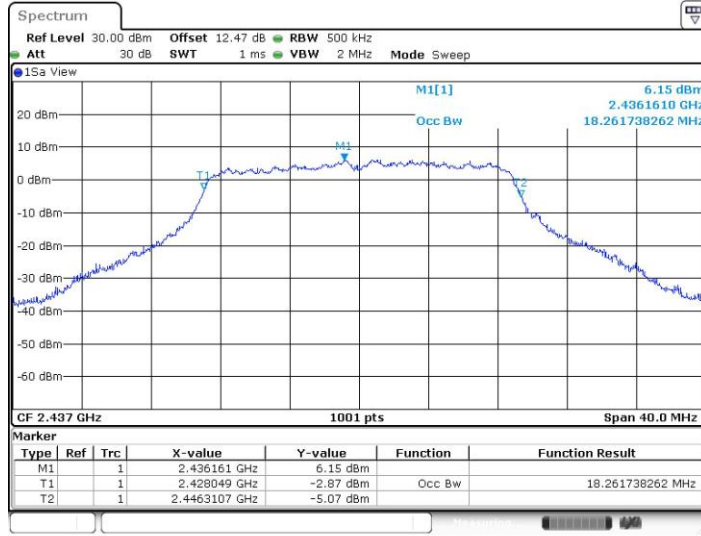

Date: 19.JAN.2022 20:03:49

11N20CDD_Ant7_2437

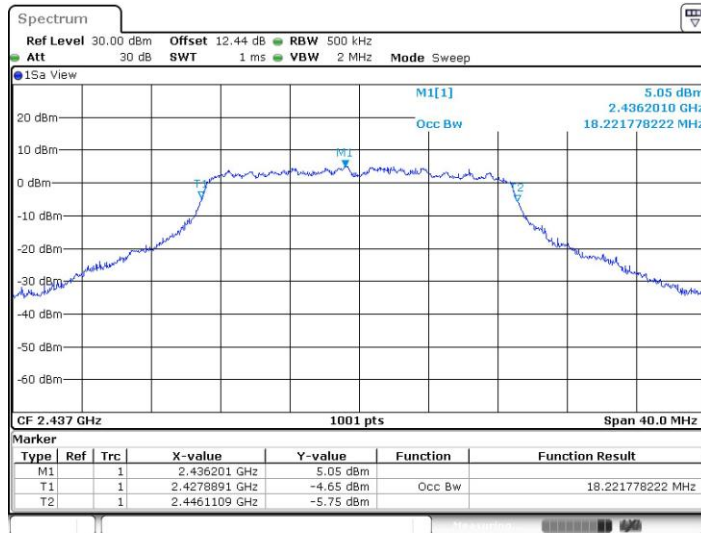

Date: 19.JAN.2022 20:05:40



11N20CDD_Ant6_2462

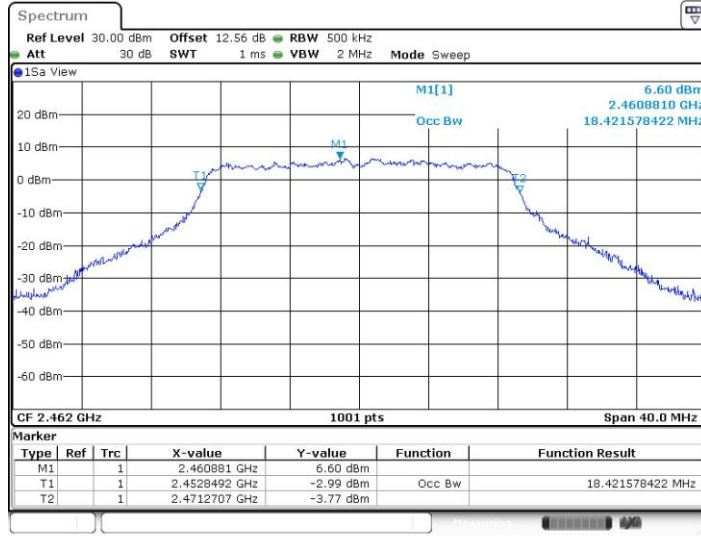

11N20CDD_Ant7_2462

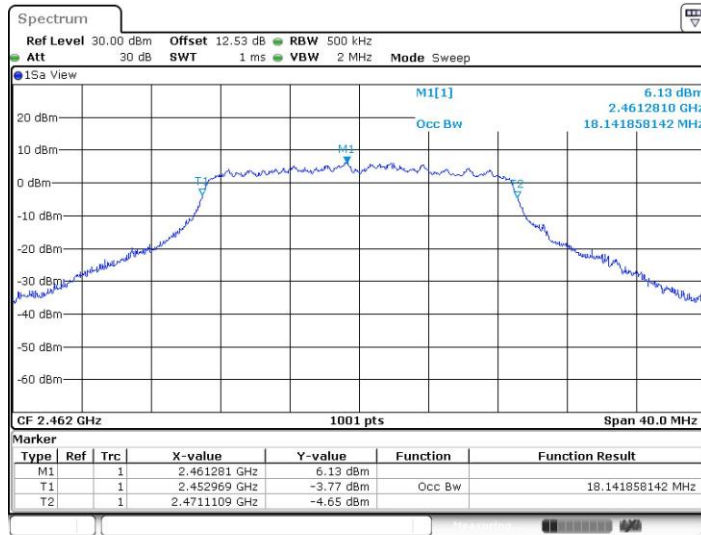



Maximum power spectral density

Test Result

TestMode	Antenna	Frequency[MHz]	Result[dBm/3kHz]	Limit[dBm/3kHz]	Verdict
11B-CDD	Ant6	2412	-12.98	≤8.00	PASS
	Ant7	2412	-13.70	≤8.00	PASS
	total	2412	-10.31	≤8.00	PASS
	Ant6	2437	-12.82	≤8.00	PASS
	Ant7	2437	-13.01	≤8.00	PASS
	total	2437	-9.90	≤8.00	PASS
	Ant6	2462	-12.52	≤8.00	PASS
	Ant7	2462	-13.04	≤8.00	PASS
	total	2462	-9.76	≤8.00	PASS
11G-CDD	Ant6	2412	-13.54	≤8.00	PASS
	Ant7	2412	-15.4	≤8.00	PASS
	total	2412	-11.36	≤8.00	PASS
	Ant6	2437	-13.59	≤8.00	PASS
	Ant7	2437	-15.83	≤8.00	PASS
	total	2437	-11.56	≤8.00	PASS
	Ant6	2462	-13.61	≤8.00	PASS
	Ant7	2462	-15.21	≤8.00	PASS
	total	2462	-11.33	≤8.00	PASS
11N20CDD	Ant6	2412	-12.67	≤8.00	PASS
	Ant7	2412	-14.73	≤8.00	PASS
	total	2412	-10.57	≤8.00	PASS
	Ant6	2437	-14.69	≤8.00	PASS
	Ant7	2437	-15.91	≤8.00	PASS
	total	2437	-12.25	≤8.00	PASS
	Ant6	2462	-12.98	≤8.00	PASS
	Ant7	2462	-13.86	≤8.00	PASS
	total	2462	-10.39	≤8.00	PASS



Test Graphs

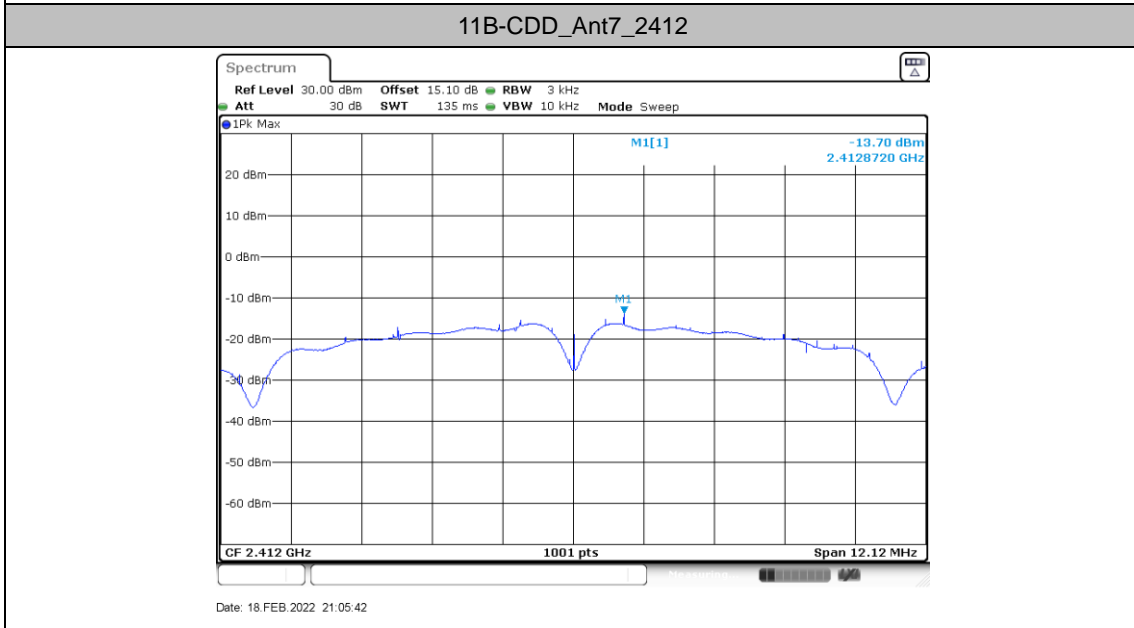
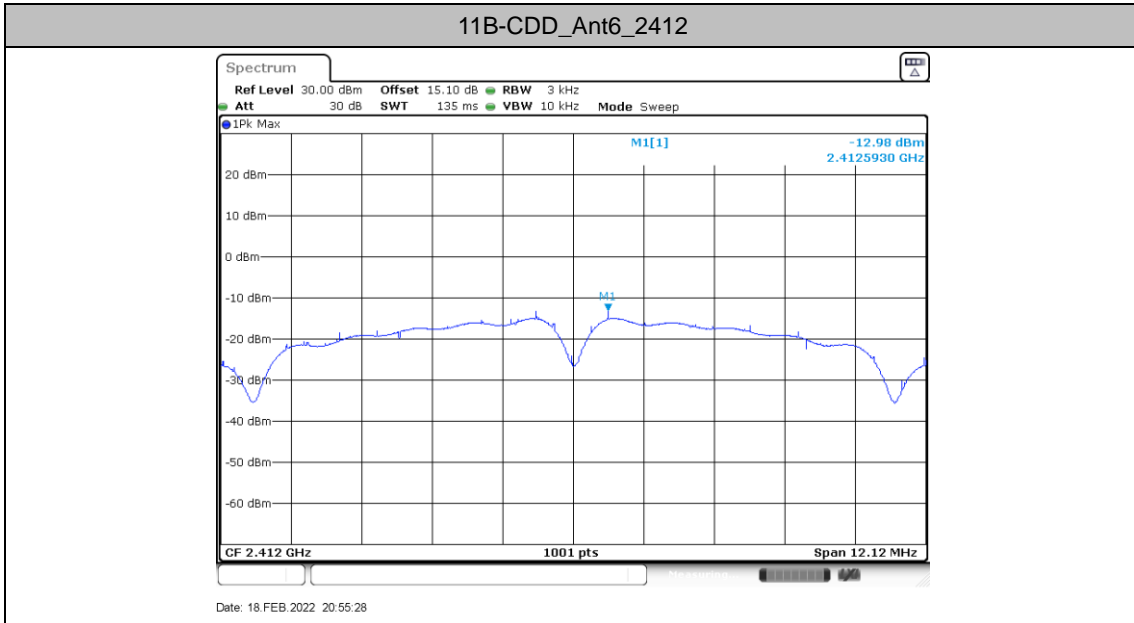



11B-CDD_Ant6_2437

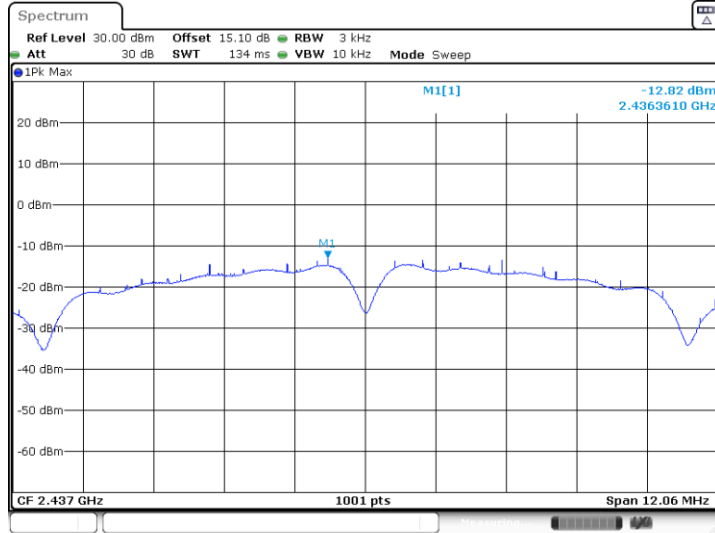

Date: 18.FEB.2022 21:00:04

11B-CDD_Ant7_2437

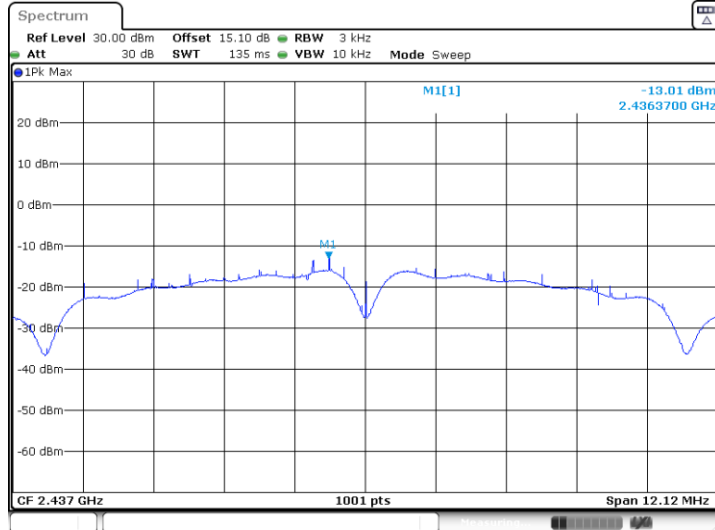

Date: 18.FEB.2022 21:09:28



11B-CDD_Ant6_2462

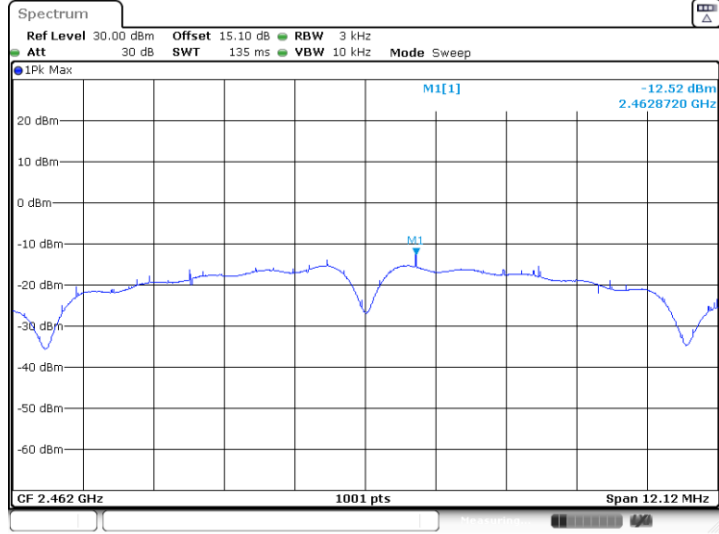

Date: 18.FEB.2022 21:03:27

11B-CDD_Ant7_2462

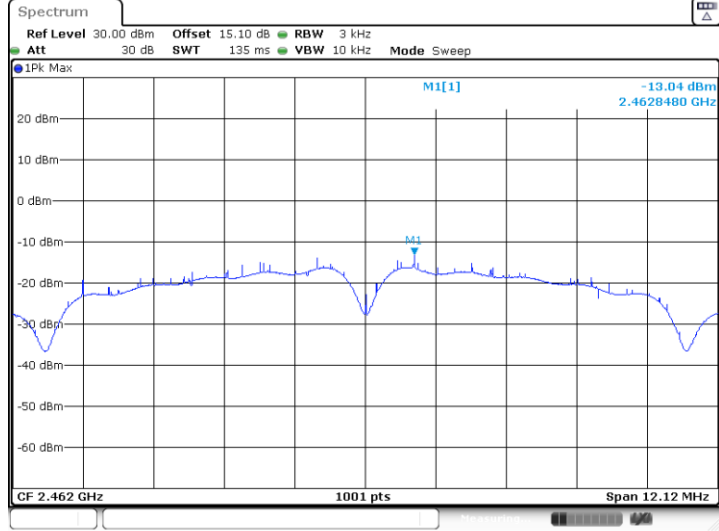

Date: 18.FEB.2022 21:11:52



11G-CDD_Ant6_2412

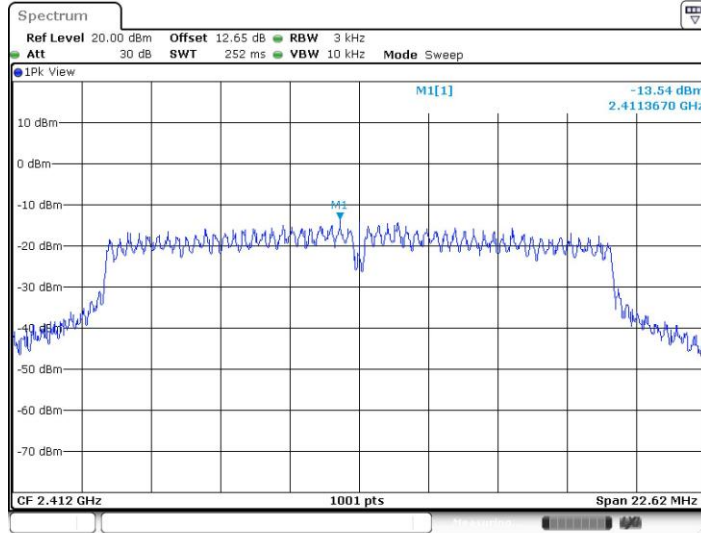

Date: 19.JAN.2022 19:37:31

11G-CDD_Ant7_2412

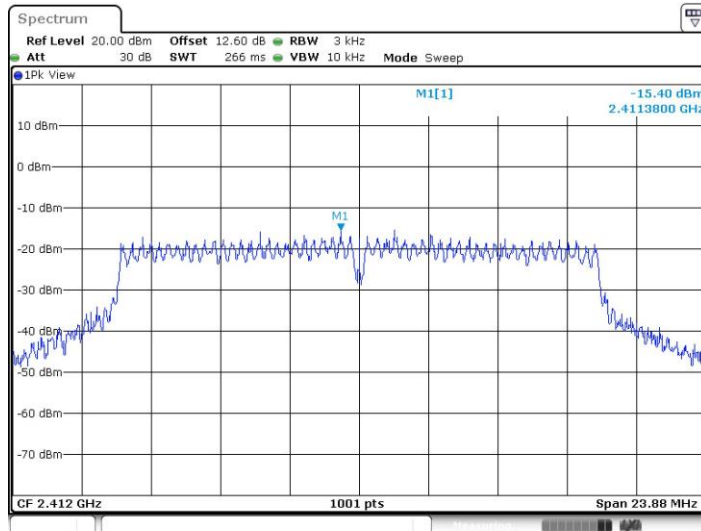

Date: 19.JAN.2022 19:39:40



11G-CDD_Ant6_2437

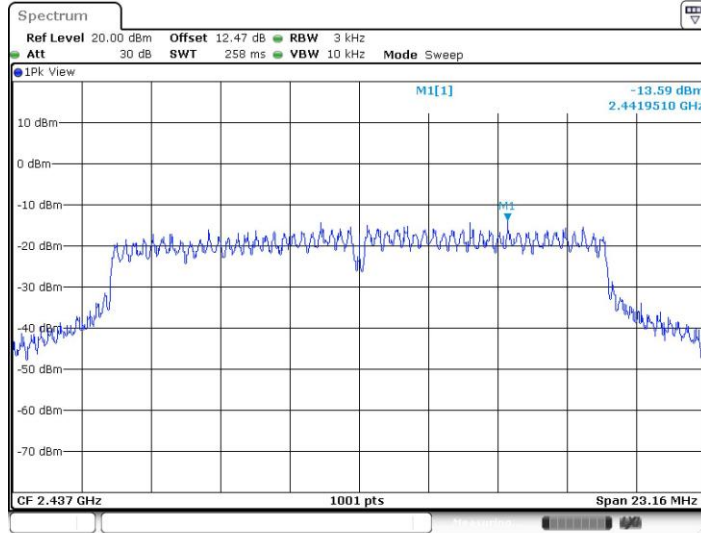

Date: 19.JAN.2022 19:42:01

11G-CDD_Ant7_2437

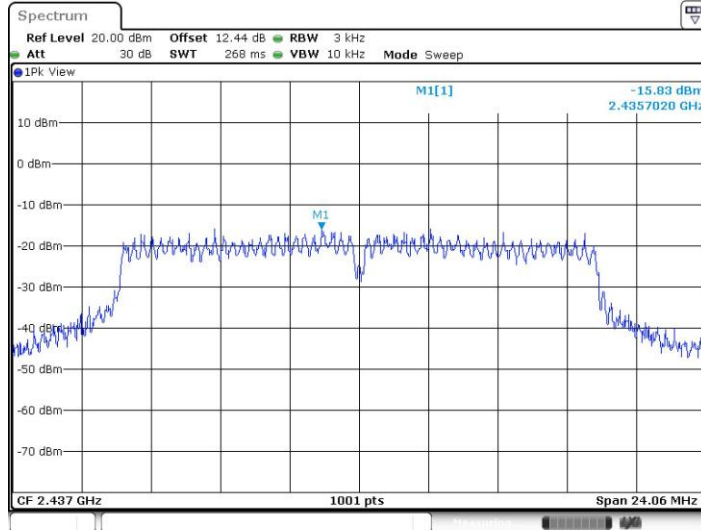

Date: 19.JAN.2022 19:43:49



11G-CDD_Ant6_2462

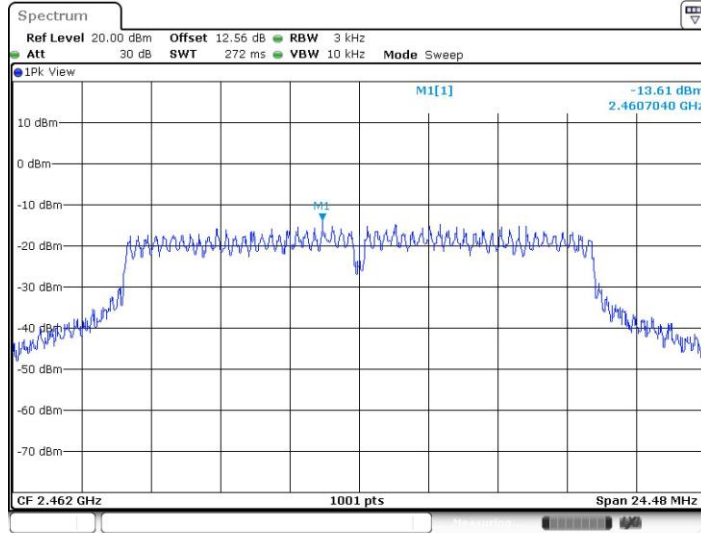

Date: 19.JAN.2022 19:49:30

11G-CDD_Ant7_2462

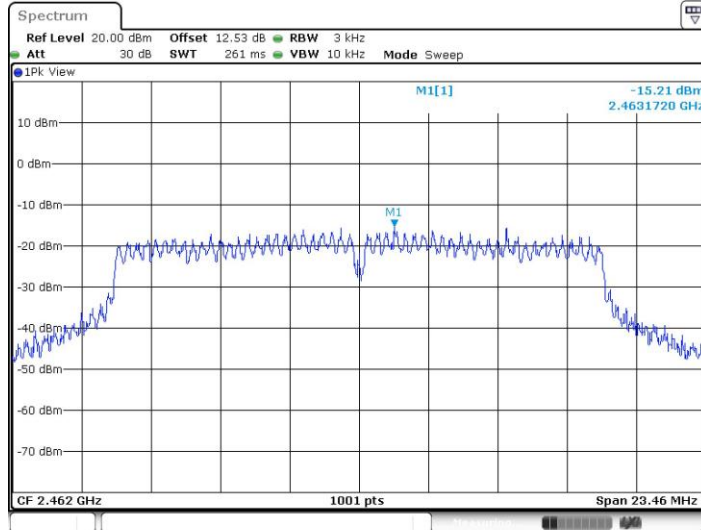

Date: 19.JAN.2022 19:51:39



11N20CDD_Ant6_2412

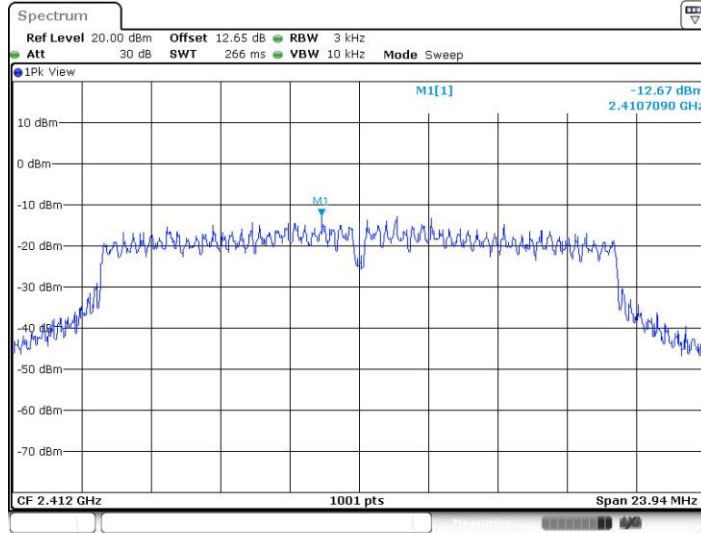

Date: 19.JAN.2022 19:55:18

11N20CDD_Ant7_2412

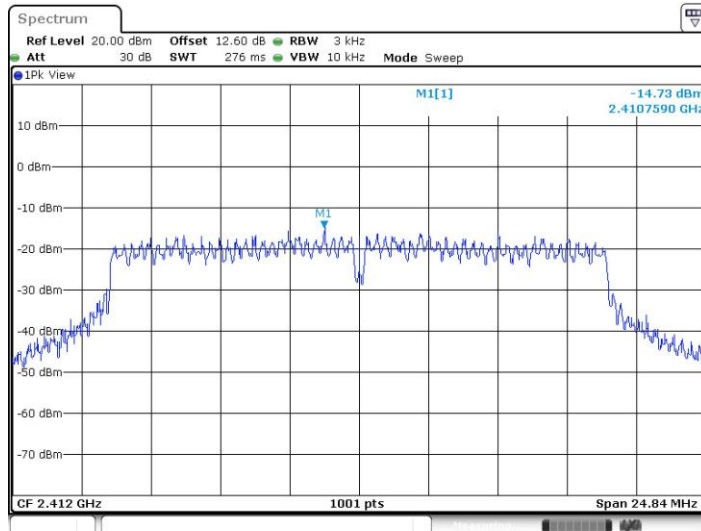

Date: 19.JAN.2022 19:57:25



11N20CDD_Ant6_2437

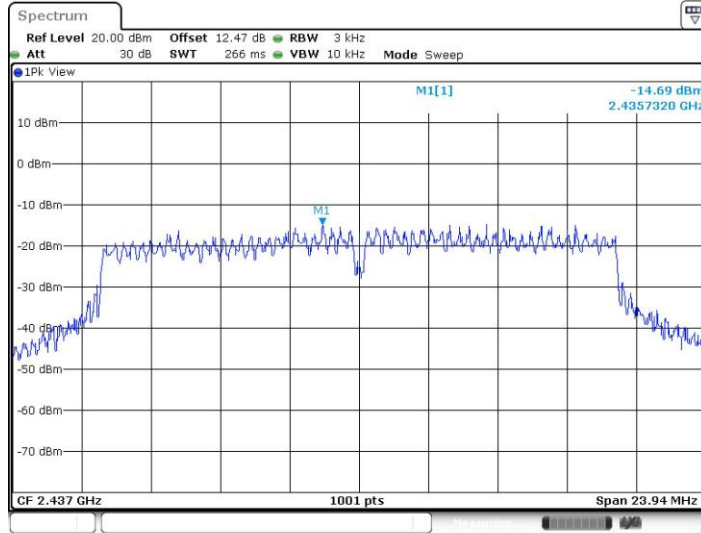

Date: 19.JAN.2022 20:04:01

11N20CDD_Ant7_2437

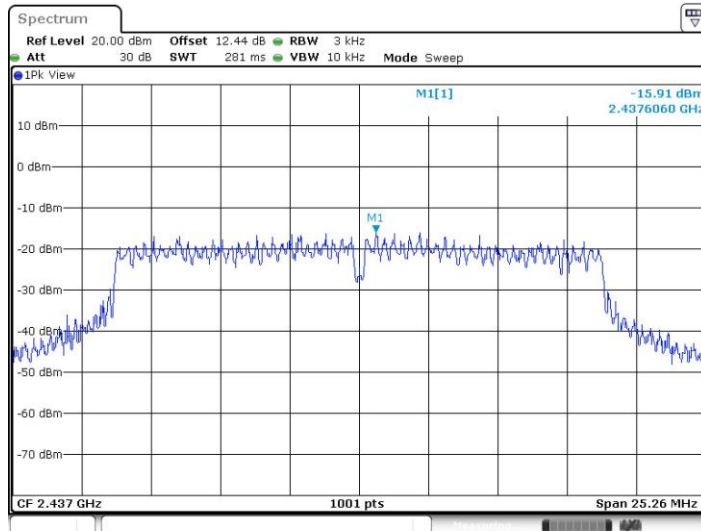

Date: 19.JAN.2022 20:05:52



11N20CDD_Ant6_2462

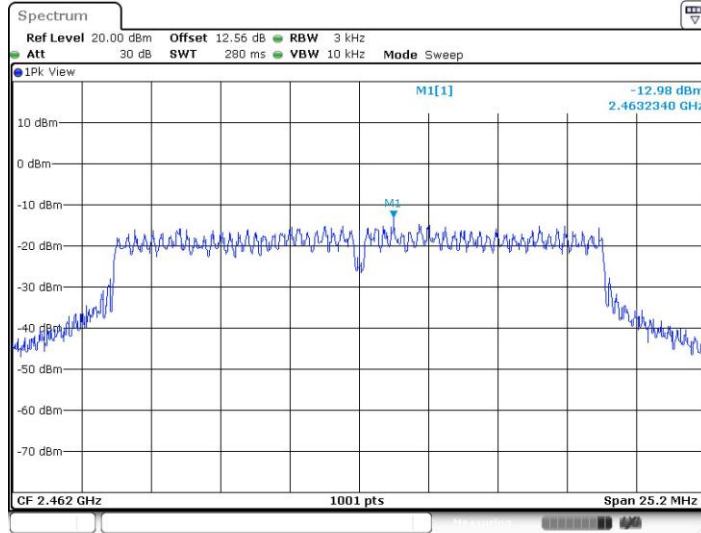

11N20CDD_Ant7_2462

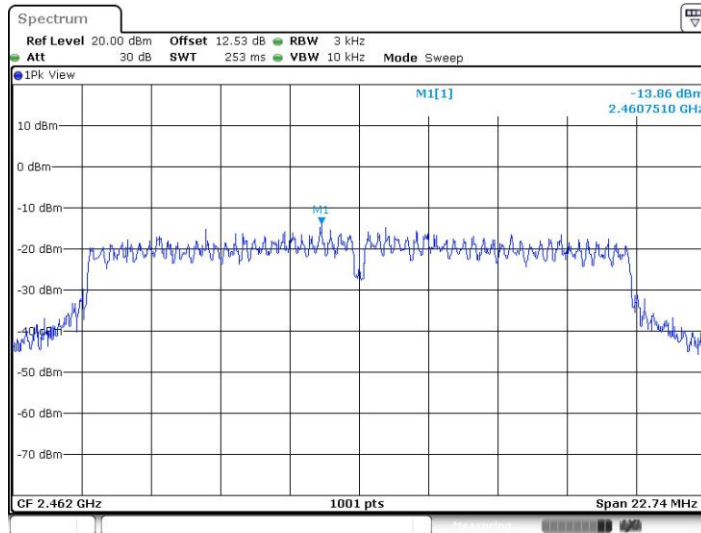



100kHz PSD Reference level measurement

Test Result

TestMode	Antenna	Freq(MHz)	Max.Point[MHz]	Result[dBm]
11B-CDD	Ant6	2412	2411.00	4.45
	Ant7	2412	2411.00	2.40
	Ant6	2437	2438.00	4.22
	Ant7	2437	2436.00	2.55
	Ant6	2462	2463.00	3.77
	Ant7	2462	2461.00	2.93
11G-CDD	Ant6	2412	2410.72	2.96
	Ant7	2412	2410.76	0.83
	Ant6	2437	2439.48	2.23
	Ant7	2437	2438.22	-0.01
	Ant6	2462	2463.28	1.31
	Ant7	2462	2460.74	0.83
11N20CDD	Ant6	2412	2410.75	3.59
	Ant7	2412	2407.00	0.86
	Ant6	2437	2438.25	2.42
	Ant7	2437	2435.72	1.21
	Ant6	2462	2463.28	2.40
	Ant7	2462	2460.72	1.77



Test Graphs

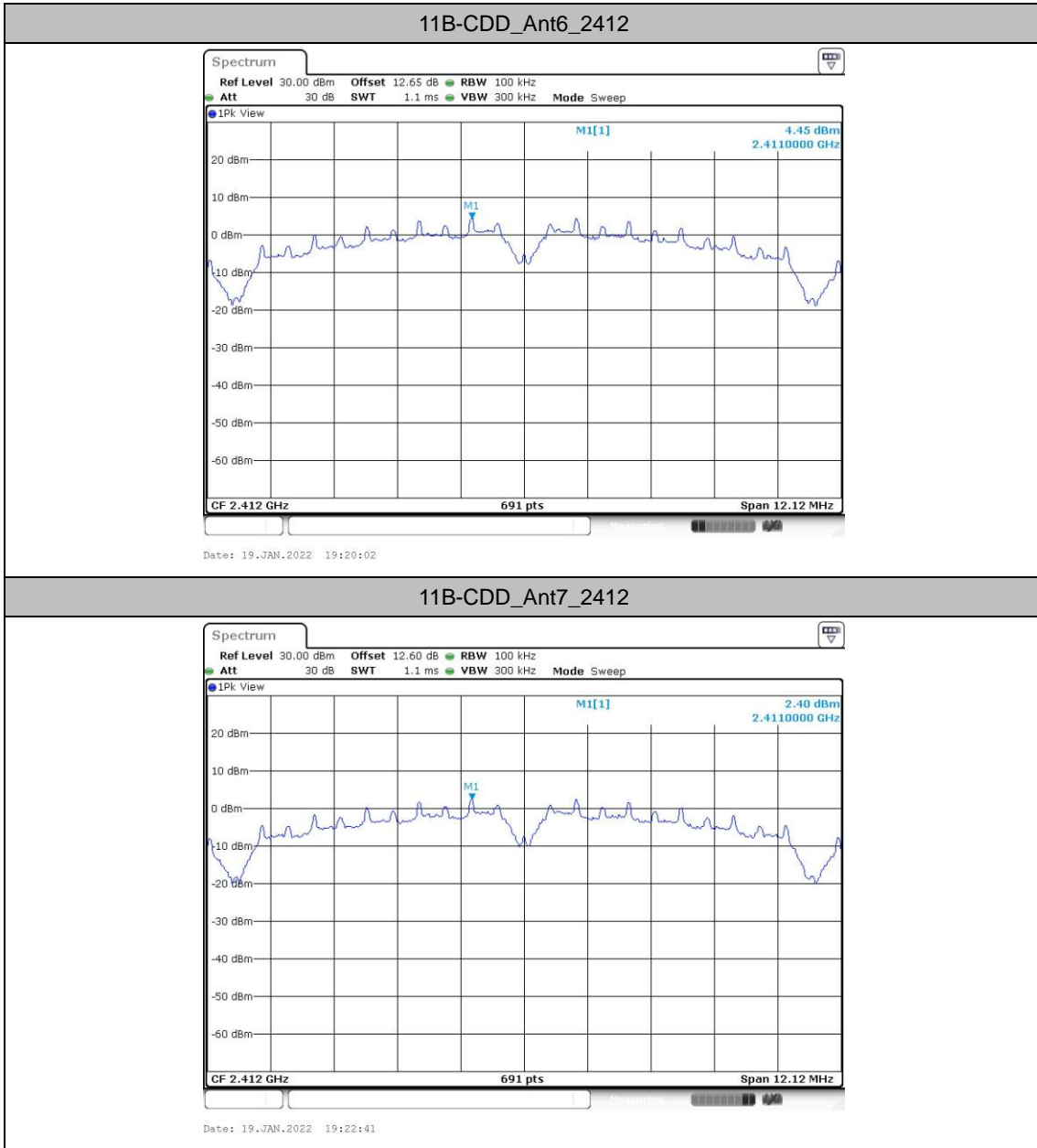



11B-CDD_Ant6_2437

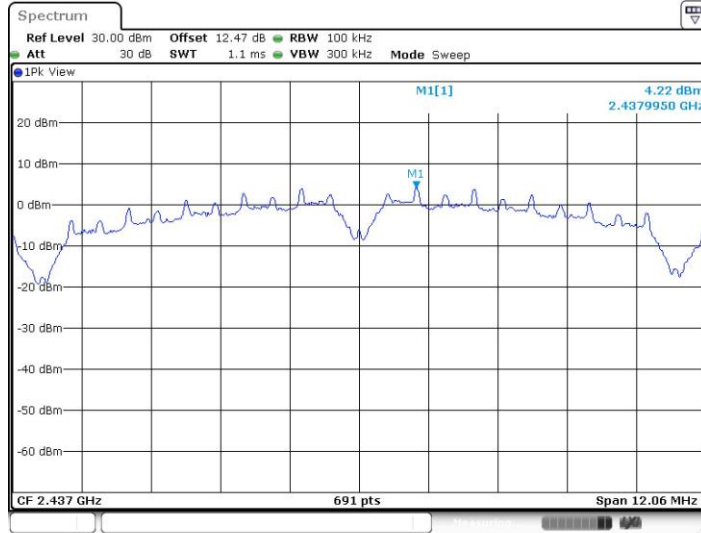

Date: 19.JAN.2022 19:26:20

11B-CDD_Ant7_2437

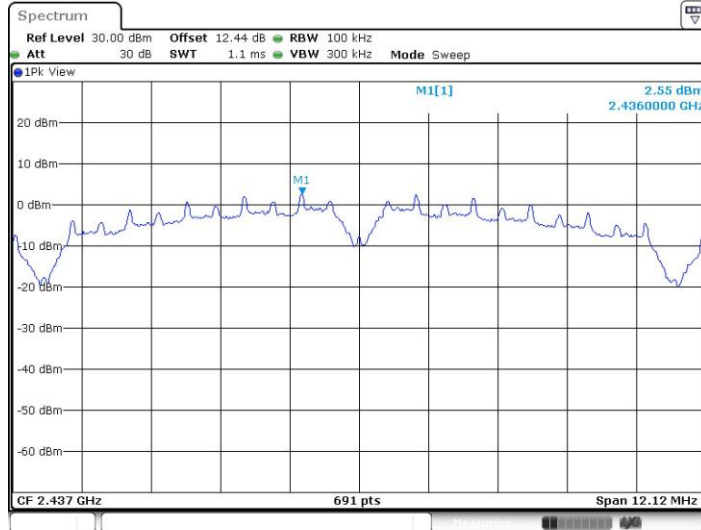

Date: 19.JAN.2022 19:28:39



11B-CDD_Ant6_2462

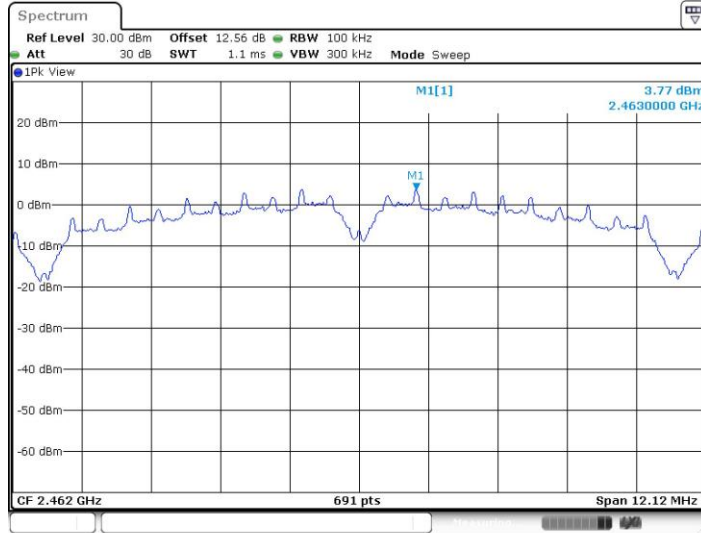

Date: 19.JAN.2022 19:31:37

11B-CDD_Ant7_2462

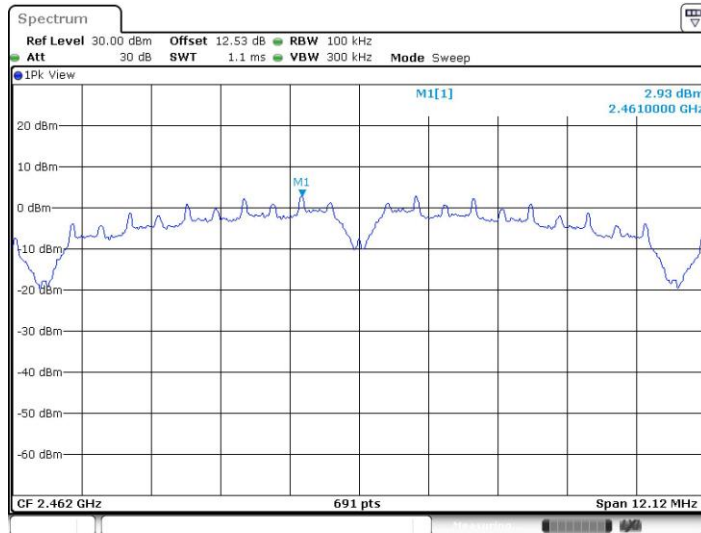

Date: 19.JAN.2022 19:34:18



11G-CDD_Ant6_2412

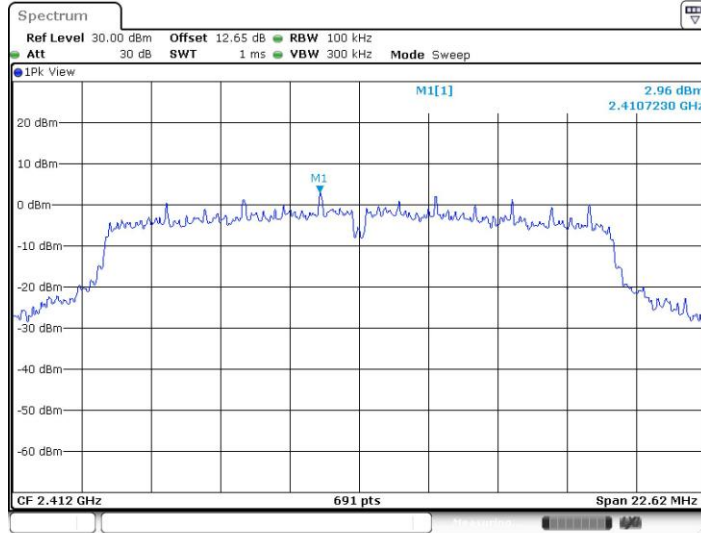

Date: 19.JAN.2022 19:37:42

11G-CDD_Ant7_2412

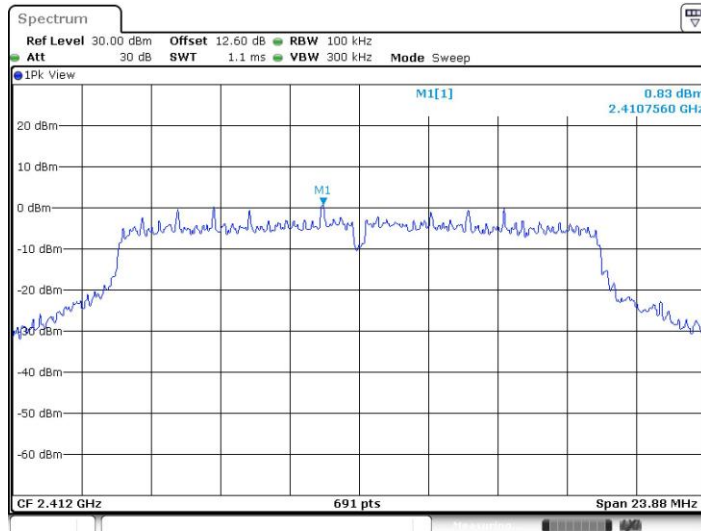

Date: 19.JAN.2022 19:39:49



11G-CDD_Ant6_2437

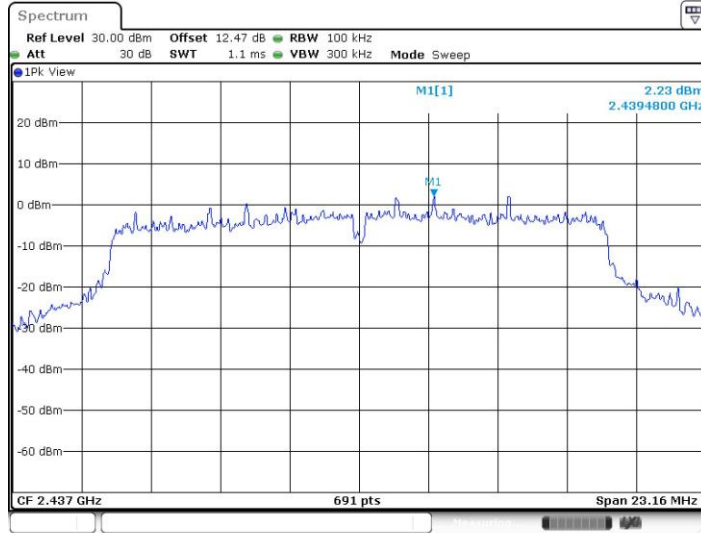

Date: 19.JAN.2022 19:42:08

11G-CDD_Ant7_2437

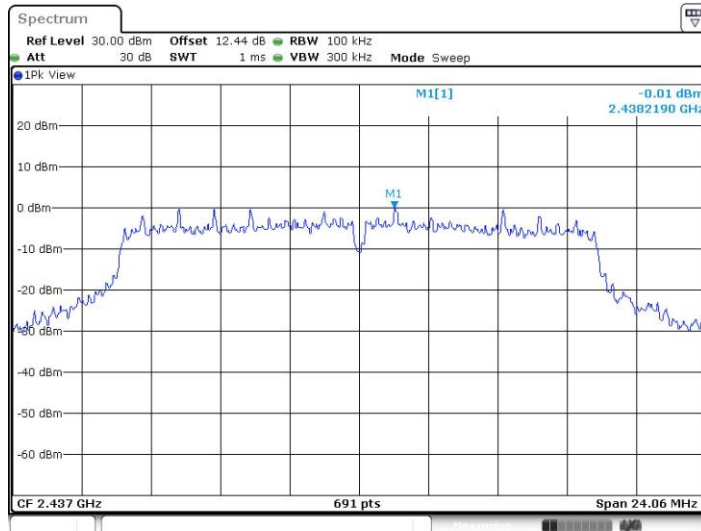

Date: 19.JAN.2022 19:43:58



11G-CDD_Ant6_2462

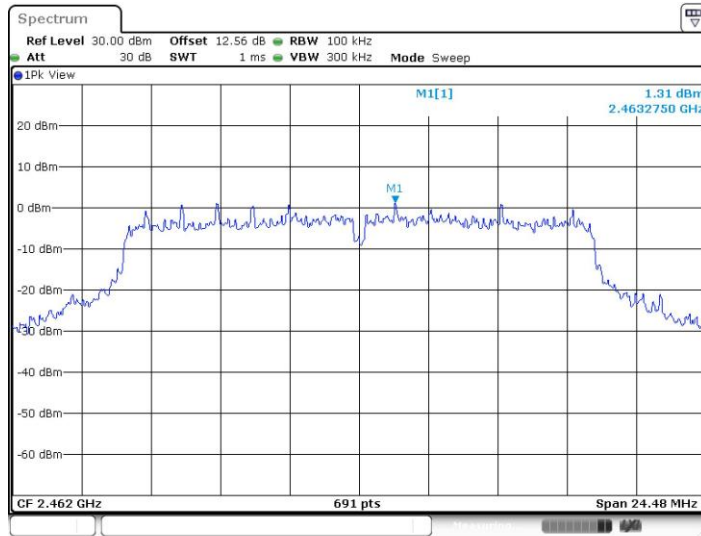

11G-CDD_Ant7_2462

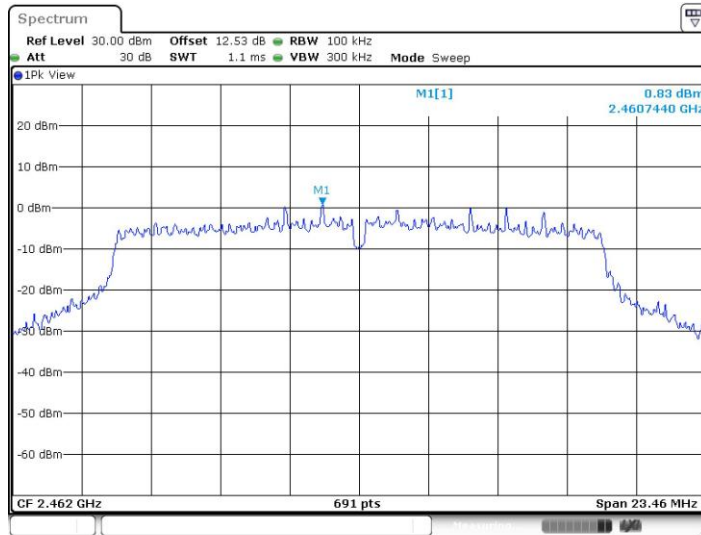



11N20CDD_Ant6_2412

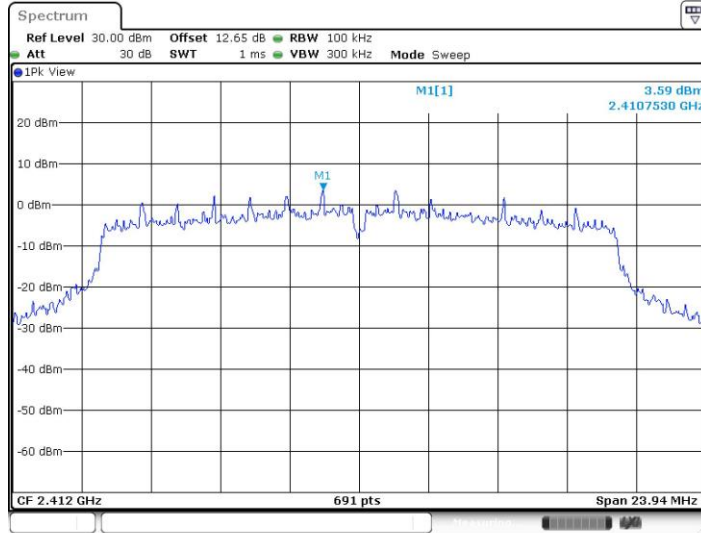

Date: 19.JAN.2022 19:55:26

11N20CDD_Ant7_2412

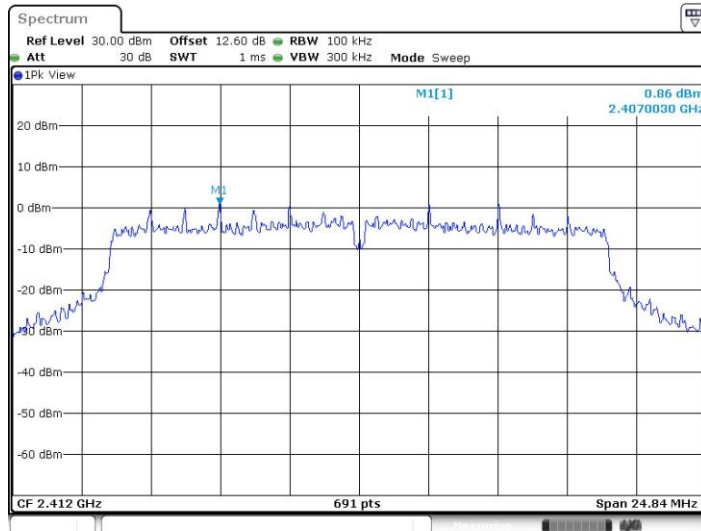

Date: 19.JAN.2022 19:57:33



11N20CDD_Ant6_2437

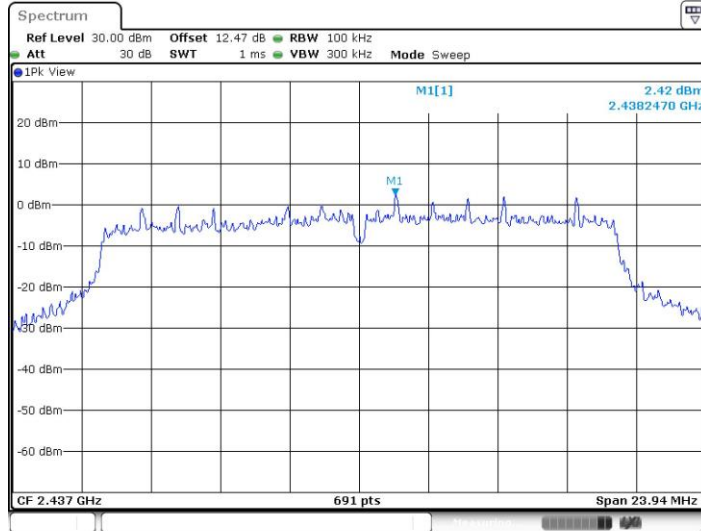

11N20CDD_Ant7_2437

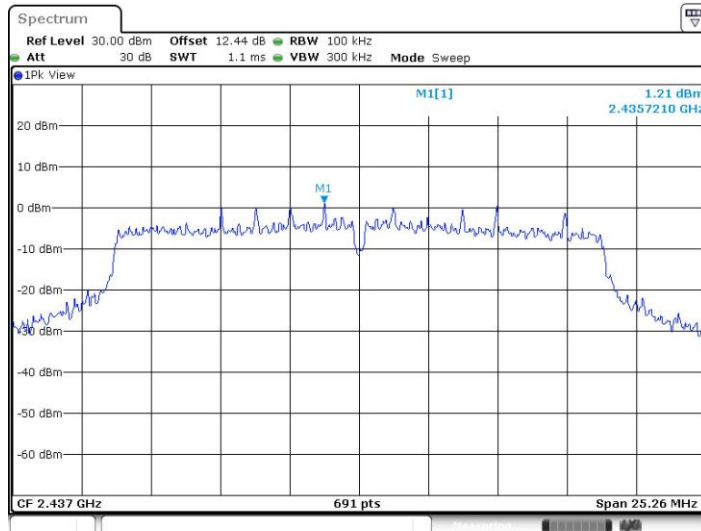



11N20CDD_Ant6_2462

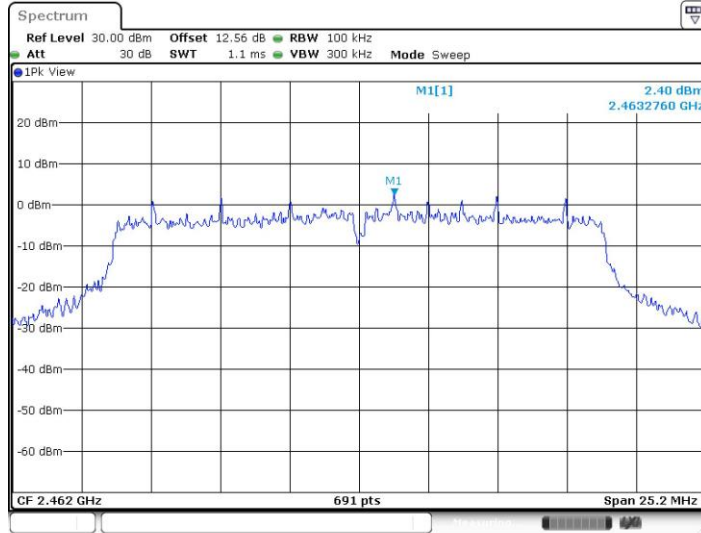

11N20CDD_Ant7_2462

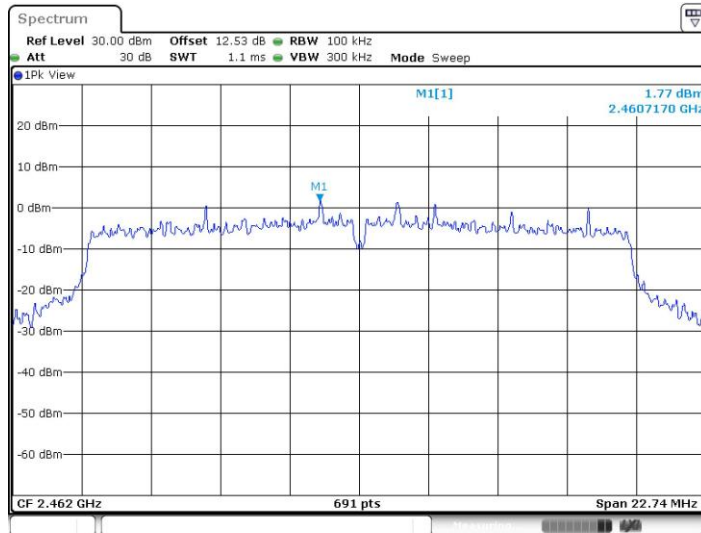



Band edge measurements

Test Result

TestMode	Antenna	ChName	Frequency[MHz]	RefLevel[dBm]	Result[dBm]	Limit[dBm]	Verdict
11B-CDD	Ant6	Low	2412	4.45	-43.07	≤-15.55	PASS
	Ant7	Low	2412	2.40	-41.83	≤-17.6	PASS
	Ant6	High	2462	3.77	-44.24	≤-16.23	PASS
	Ant7	High	2462	2.93	-44.58	≤-17.07	PASS
11G-CDD	Ant6	Low	2412	2.96	-29.19	≤-17.04	PASS
	Ant7	Low	2412	0.83	-30.36	≤-19.17	PASS
	Ant6	High	2462	1.31	-43.91	≤-18.69	PASS
	Ant7	High	2462	0.83	-43.83	≤-19.17	PASS
11N20CDD	Ant6	Low	2412	3.59	-26.92	≤-16.41	PASS
	Ant7	Low	2412	0.86	-28.05	≤-19.14	PASS
	Ant6	High	2462	2.40	-43.37	≤-17.6	PASS
	Ant7	High	2462	1.77	-43.57	≤-18.23	PASS