



FCC RADIO TEST REPORT

FCC ID : PY7-81713C
Equipment : GSM/WCDMA/LTE Phone with BT, DTS/UNII
a/b/g/n/ac, NFC, FM receiver and GNSS
Brand Name : SONY
Applicant : Sony Corporation
1-7-1 Konan Minato-ku Tokyo, 108-0076 Japan
Manufacturer : Sony Corporation
1-7-1 Konan Minato-ku Tokyo, 108-0076 Japan
Standard : FCC Part 15 Subpart C §15.225
Test Date(s) : Dec. 18, 2021 ~ Jan. 07, 2022

We, Sporton International Inc. (Kunshan), would like to declare that the tested sample has been evaluated in accordance with the test procedures and has been in compliance with the applicable technical standards.

The test results in this report apply exclusively to the tested model / sample. Without written approval of Sporton International Inc. (Kunshan), the test report shall not be reproduced except in full.

Jason Jia

Reviewed by: Jason Jia / Supervisor

Alex Wang

Approved by: Alex Wang / Manager



Sporton International Inc. (Kunshan)
No. 1098, Pengxi North Road, Kunshan Economic Development Zone Jiangsu Province 215300
People's Republic of China



Table of Contents

History of this test report..... 3

Summary of Test Result..... 4

1. General Description 5

 1.1 Product Feature of Equipment Under Test 5

 1.2 Modification of EUT 5

 1.3 Testing Location 5

 1.4 Applicable Standards..... 6

2. Test Configuration of Equipment Under Test..... 7

 2.1 Descriptions of Test Mode 7

 2.2 Connection Diagram of Test System 8

 2.3 Table for Supporting Units 9

 2.4 EUT Operation Test Setup 9

3. Test Results 10

 3.1 AC Power Line Conducted Emissions Measurement 10

 3.2 20dB and 99% OBW Spectrum Bandwidth Measurement..... 12

 3.3 Frequency Stability Measurement 13

 3.4 Field Strength of Fundamental Emissions and Mask Measurement..... 14

 3.5 Radiated Emissions Measurement 16

 3.6 Antenna Requirements..... 19

4. List of Measuring Equipment 20

5. Uncertainty of Evaluation 21

Appendix A. Test Results of Conducted Emission Test

Appendix B. Test Results of Conducted Test Items

 B1. Test Result of 20dB Spectrum Bandwidth

 B2. Test Result of Frequency Stability

Appendix C. Test Results of Radiated Test Items

 C1. Test Result of Field Strength of Fundamental Emissions

 C2. Results of Radiated Emissions (9 kHz~30MHz)

 C3. Results of Radiated Emissions (30MHz~1GHz)



Summary of Test Result

Report Clause	Ref Std. Clause	Test Items	Result (PASS/FAIL)	Remark
3.1	15.207	AC Power Line Conducted Emissions	Pass	Under limit 8.10 dB at 0.214MHz
3.2	15.215(c)	20dB Spectrum Bandwidth	Pass	-
	2.1049	99% OBW Spectrum Bandwidth	Reporting only	-
3.3	15.225(e)	Frequency Stability	Pass	-
3.4	15.225(a)(b)(c)	Field Strength of Fundamental Emissions	Pass	Max level 17.60 dB μ V/m at 13.560 MHz
3.5	15.225(d) 15.209	Radiated Spurious Emissions	Pass	Under limit 9.82 dB at 40.67MHz
3.6	15.203	Antenna Requirements	Pass	-

Declaration of Conformity:

The test results with all measurement uncertainty excluded are presented in accordance with the regulation limits or requirements declared by manufacturers.

Comments and Explanations:

The declared of product specification for EUT presented in the report are provided by the manufacturer, and the manufacturer takes all the responsibilities for the accuracy of product specification.



1. General Description

1.1 Product Feature of Equipment Under Test

GSM/WCDMA/LTE, Bluetooth, DTS/UNII a/b/g/n/ac, NFC, FM Receiver, and GNSS

Standards-related Product Specification	
Antenna Type	Loop Antenna

Remark: The above EUT's information was declared by manufacturer. Please refer to Comments and Explanations in report summary.

EUT Information List			
HW Version	SW Version	IMEI Code	Performed Test Item
A	0.386	004402543133270	RF conducted measurement
		004402543133445	Radiated Spurious Emission
		004402543133445	AC Conducted Emission

Note: For other wireless features of this EUT, test report will be issued separately.

1.2 Modification of EUT

No modifications are made to the EUT during all test items.

1.3 Testing Location

Sporton International Inc. (Kunshan) is accredited to ISO/IEC 17025:2017 by American Association for Laboratory Accreditation with Certificate Number 5145.02.

Test Site	Sporton International Inc. (Kunshan)				
Test Site Location	No. 1098, Pengxi North Road, Kunshan Economic Development Zone Jiangsu Province 215300 People's Republic of China TEL : +86-512-57900158 FAX : +86-512-57900958				
Test Site No.	Sporton Site No.			FCC Designation No.	FCC Test Firm Registration No.
	TH01-KS	03CH02-KS	CO01-KS	CN1257	314309
Test Engineer	You Zhou	Yoke Si	Amos Zhang		
Temperature	22~24°C	21~22°C	25.3~26.2°C		
Relative Humidity	53~55%	41~42%	38~40%		



1.4 Applicable Standards

According to the specifications of the manufacturer, the EUT must comply with the requirements of the following standards:

- ♦ FCC Part 15 Subpart C §15.225
- ♦ FCC KDB 414788 D01 Radiated Test Site v01r01
- ♦ ANSI C63.10-2013

Remark:

1. All test items were verified and recorded according to the standards and without any deviation during the test.
2. This EUT has also been tested and complied with the requirements of FCC Part 15, Subpart B, recorded in a separate test report.



2. Test Configuration of Equipment Under Test

2.1 Descriptions of Test Mode

Investigation has been done on all the possible configurations.

The following table is a list of the test modes shown in this test report.

Test Items	
AC Power Line Conducted Emissions	Field Strength of Fundamental Emissions
20dB Spectrum Bandwidth	Frequency Stability
Radiated Emissions 9kHz~30MHz	Radiated Emissions 30MHz~1GHz

The NFC test is performed with app “NFC PRBS Test Mode” installed in the mobile phone. It can enable continuous transmission with type F tag respectively.

The EUT pre-scanned in four NFC type, A, B, F, V. The worst type (type F) was recorded in this report. For radiated measurement, the measured emission level of the EUT was maximized by rotating the EUT on a turntable, adjusting the orientation of the EUT and EUT antenna in three orthogonal axis (X: flat, Y: portrait, Z: landscape), and adjusting the measurement antenna orientation, following C63.10 exploratory test procedures and find Y plane as worst plane. The worst case position of the EUT was investigated under two configurations: EUT with AC adapter and earphone, EUT with standalone. The worst-case configuration for with tag mode is the EUT with AC adapter and headphone mode, and the worst-case configuration for without tag mode is the EUT with standalone configuration.

Test Cases	
AC Conducted Emission	Mode 1:NFC Tx + GSM850 Idle + Bluetooth Link + WLAN (2.4GHz) Link + Earphone + USB Cable 1(Charging from AC Adapter)

2.2 Connection Diagram of Test System

<AC Conducted Emissions>

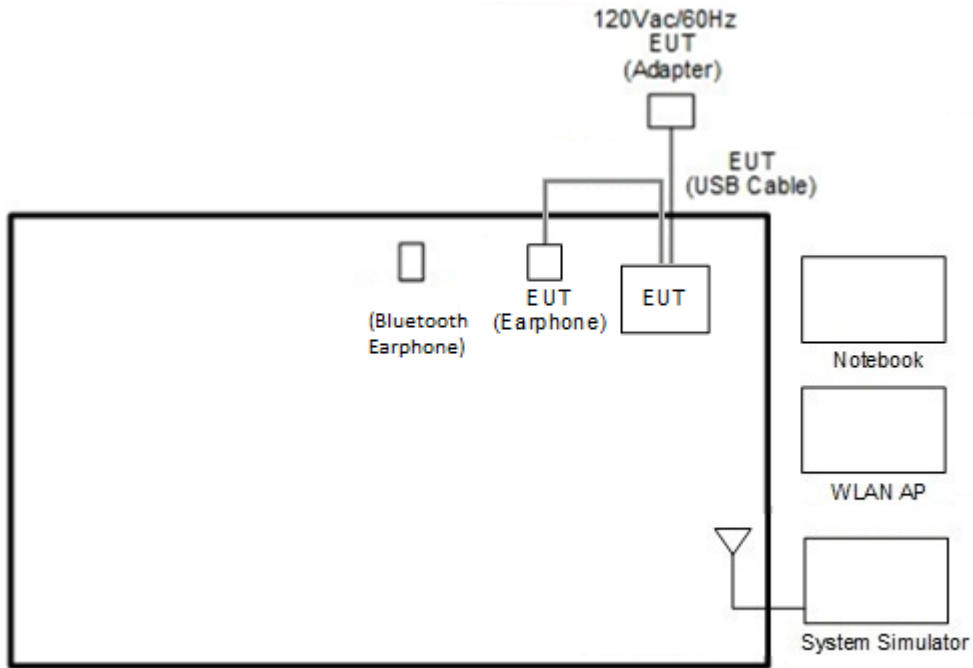

<For Radiated Emissions Measurement with Tx Tool>



<For Radiated Emissions Measurement with NFC Card>

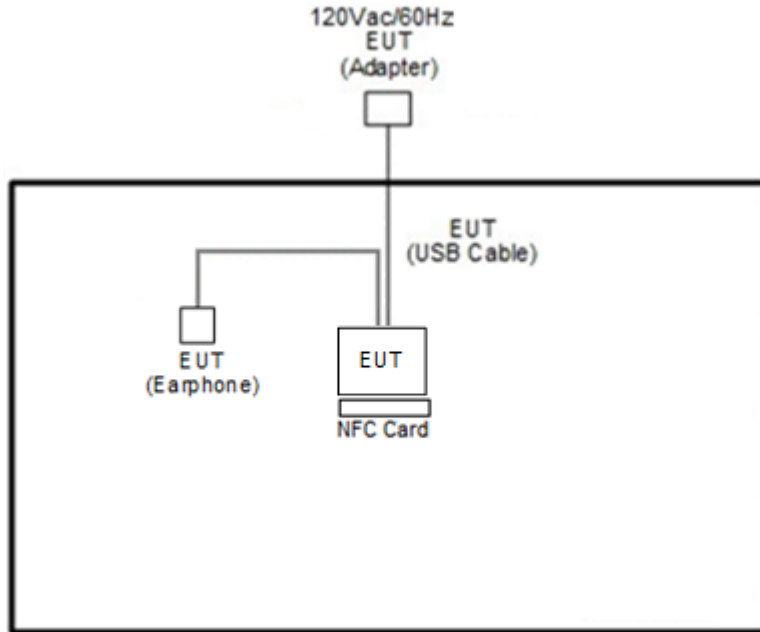

2.3 Table for Supporting Units

Item	Equipment	Brand Name	Model Name	FCC ID	Data Cable	Power Cord
1.	Base Station	Anritus	MT8821C	N/A	N/A	Unshielded, 1.8m
2.	Notebook	Lenovo	G480	QDS-BRCM1050I	N/A	Shielded cable DC O/P 1.8m, Unshielded AC I/P cable 1.8m
3.	WLAN AP	D-link	DIR-655	KA21R655B1	N/A	Unshielded, 1.8m
4.	NFC Card	N/A	N/A	N/A	N/A	N/A
5.	Bluetooth Earphone	Sony	SBH82D	PY7-33726V	N/A	N/A

2.4 EUT Operation Test Setup

The EUT was programmed to be in continuously transmitting mode.

With tag: The ancillary equipment, NFC card, is used to make the EUT (NFC) continuously transmitting signal (Power Level: Default) at 13.56MHz and is placed around 1 cm gap to the EUT.

Without tag: The RF Tx tool test items, utility “NFC PRBS Test Mode” was installed in Notebook which was programmed in order to make the EUT get into the engineering modes to provide channel selection, power level (Power setting: Default), data rate (Type F Bit Rate: 424kbps) and the application type and for continuous transmitting signals.

3. Test Results

3.1 AC Power Line Conducted Emissions Measurement

3.1.1 Limit of AC Conducted Emission

For equipment that is designed to be connected to the public utility (AC) power line, the radio frequency voltage that is conducted back onto the AC power line on any frequency or frequencies within the band 150 kHz to 30 MHz shall not exceed the limits in the following table.

Frequency of Emission (MHz)	Conducted Limit (dB μ V)	
	Quasi-Peak	Average
0.15-0.5	66 to 56*	56 to 46*
0.5-5	56	46
5-30	60	50

*Decreases with the logarithm of the frequency.

For terminal test result, the testing follows FCC KDB 174176.

3.1.2 Measuring Instruments

See list of measuring equipment of this test report.

3.1.3 Test Procedures

1. The EUT was placed 0.4 meter from the conducting wall of the shielding room, and it was kept at least 80 centimeters from any other grounded conducting surface.
2. Connect EUT to the power mains through a line impedance stabilization network (LISN).
3. All the support units are connecting to the other LISN.
4. The LISN provides 50 ohm coupling impedance for the measuring instrument.
5. The FCC states that a 50 ohm, 50 microhenry LISN shall be used.
6. Both sides of AC line were checked for maximum conducted interference.
7. The frequency range from 150 kHz to 30 MHz was searched.
8. Set the test-receiver system to Peak Detect Function and specified bandwidth (IF Bandwidth = 9kHz) with Maximum Hold Mode. Then measurement is also conducted by Average Detector and Quasi-Peak Detector Function respectively.

3.1.4 Test setup

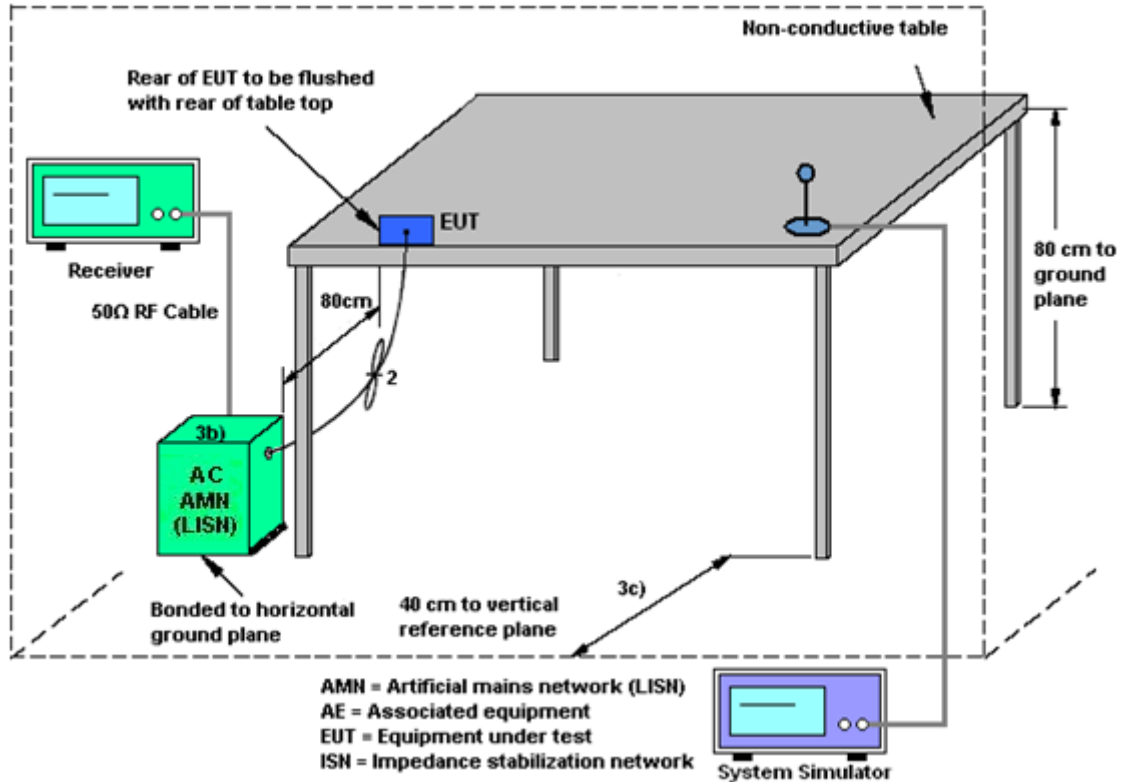

3.1.5 Test Result of AC Conducted Emission

Please refer to Appendix A.

Note:

(1) with antenna

Remark: 13.560MHz is the NFC RF fundamental signal.

(2) with dummy load

Remark: Only the fundamental NFC signal needs to be retested per C63.4.

3.2 20dB and 99% OBW Spectrum Bandwidth Measurement

3.2.1 Limit

Intentional radiators must be designed to ensure that the 20 dB and 99% emission bandwidth in the specific band 13.553~13.567 MHz.

3.2.2 Measuring Instruments

See list of measuring instruments of this test report.

3.2.3 Test Procedures

1. The spectrum analyzer connected via a receive antenna placed near the EUT in peak Max Hold Mode.
2. The resolution bandwidth of 1 kHz and the video bandwidth of 3 kHz were used.
3. Measured the spectrum width with power higher than 20 dB below carrier.
4. Measured the 99% OBW.

3.2.4 Test Setup



3.2.5 Test Result of Conducted Test Items

Please refer to Appendix B.

3.3 Frequency Stability Measurement

3.3.1 Limit

The frequency tolerance of the carrier signal shall be maintained within +/- 0.01% (100ppm) of the operating frequency over a temperature variation of -20 degrees to +50 degrees C at normal supply voltage, and for a variation in the primary supply voltage from 85% to 115% of the rated supply voltage at a temperature of 20 degrees C. For battery operated equipment, the equipment tests shall be performed by using a new battery.

3.3.2 Measuring Instruments

See list of measuring instruments of this test report.

3.3.3 Test Procedures

1. The spectrum analyzer connected via a receive antenna placed near the EUT.
2. EUT has transmitted signal and fixed channelize.
3. Set the spectrum analyzer span to view the entire emissions bandwidth.
4. Set RBW = 1 kHz, VBW = 3 kHz with peak detector and maxhold settings.
5. The f_c is declaring of channel frequency. Then the frequency error formula is $(f_c - f) / f_c \times 10^6$ ppm and the limit is less than ± 100 ppm.
6. Extreme temperature rule is -20°C~50°C.

3.3.4 Test Setup

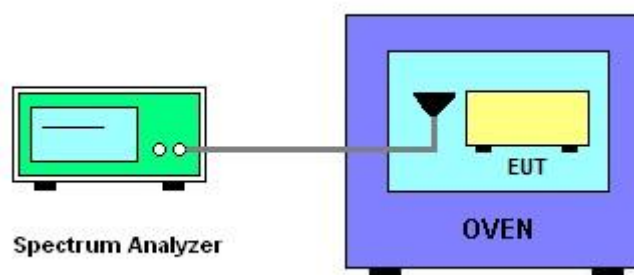

3.3.5 Test Result of Conducted Test Items

Please refer to Appendix B.



3.4 Field Strength of Fundamental Emissions and Mask Measurement

3.4.1 Limit

Rules and specifications	FCC CFR 47 Part 15 section 15.225	
Description	Compliance with the spectrum mask is tested with RBW set to 9kHz.	
Freq. of Emission (MHz)	Field Strength (μV/m) at 30m	Field Strength (dBμV/m) at 30m
1.705~13.110	30	29.5
13.110~13.410	106	40.5
13.410~13.553	334	50.5
13.553~13.567	15848	84.0
13.567~13.710	334	50.5
13.710~14.010	106	40.5
14.010~30.000	30	29.5

Remark:

1. Emission level (dBμV/m) = 20 log Emission level (μV/m).
2. The field strength test result is in 3m test distance, follow test rules the test data use distance extrapolation factor and reported in this report at 30m test result.
3. Distance extrapolation factor = 40 log (specific distance / test distance) (dB).

3.4.2 Measuring Instruments

See list of measuring instruments of this test report.

3.4.3 Test Procedures

1. Configure the EUT according to ANSI C63.10. The EUT was placed on the top of the turntable 0.8 meter above ground. The phase center of the loop receiving antenna mounted antenna tower was placed 3 meters far away from the turntable.
2. Power on the EUT and all the supporting units. The turntable was rotated by 360 degrees to determine the position of the highest radiation.
3. The height of the receiving antenna was fixed at one meter above ground to find the maximum emissions field strength.
4. For Fundamental emissions, use the receiver to measure QP reading.
5. When the radiated emissions limits are expressed in terms of the average value of the emissions, and pulsed operation is employed, the measurement field strength shall be determined by averaging over one complete pulse train, including blanking intervals, as long as the pulse train does not exceed 0.1 seconds. As an alternative (provided the transmitter operates for longer than 0.1 seconds) or in cases where the pulse train exceeds 0.1 seconds, the measured field strength shall be determined from the average absolute voltage during a 0.1 second interval during which the field strength is at its maximum value.
6. Compliance with the spectrum mask is tested with RBW set to 9 kHz.

3.4.4 Test Setup

For radiated test below 30MHz

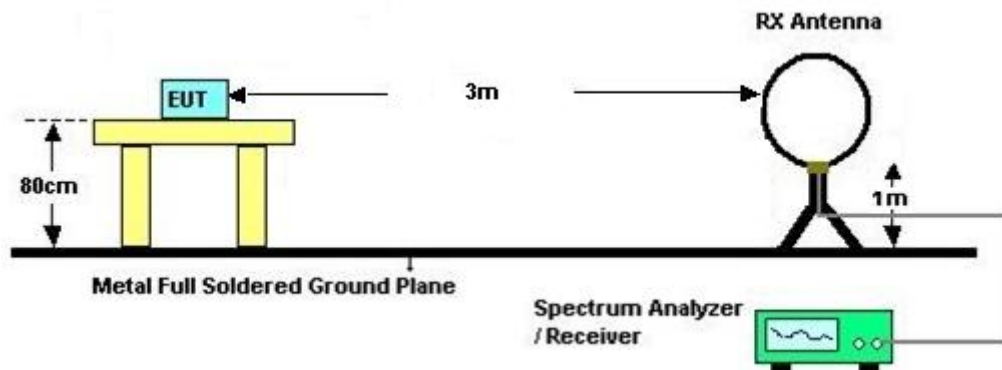

3.4.5 Test Result of Field Strength of Fundamental Emissions and Mask

Please refer to Appendix C.

3.5 Radiated Emissions Measurement

3.5.1 Limit

The field strength of any emissions which appear outside of 13.110 ~14.010MHz band shall not exceed the general radiated emissions limits.

Frequencies (MHz)	Field Strength (μV/m)	Measurement Distance (meters)
0.009~0.490	2400/F(kHz)	300
0.490~1.705	24000/F(kHz)	30
1.705~30.0	30	30
30~88	100	3
88~216	150	3
216~960	200	3
Above 960	500	3

3.5.2 Measuring Instruments

See list of measuring instruments of this test report.

3.5.3 Measuring Instrument Setting

The following table is the setting of receiver:

Receiver Parameter	Setting
Attenuation	Auto
Frequency Range: 9kHz~150kHz	RBW 200Hz for QP
Frequency Range: 150kHz~30MHz	RBW 9kHz for QP
Frequency Range: 30MHz~1000MHz	RBW 120kHz for Peak

Note: The emission limits shown in the above table are based on measurements employing a CISPR quasi-peak detector except for the frequency bands 9-90 kHz and 110-490 kHz. Radiated emission limits in these two bands are based on measurements employing an average detector.



3.5.4 Test Procedures

1. Configure the EUT according to ANSI C63.10. The EUT was placed on the top of the turntable 0.8 meter above ground. The phase center of the receiving antenna mounted on the top of a height-variable antenna tower was placed 3 meters far away from the turntable.
2. Power on the EUT and all the supporting units. The turntable was rotated by 360 degrees to determine the position of the highest radiation.
3. The height of the broadband receiving antenna was varied between one meter and four meters above ground to find the maximum emissions field strength of both horizontal and vertical polarization.
4. For each suspected emissions, the antenna tower was scan (from 1 M to 4 M) and then the turntable was rotated (from 0 degree to 360 degrees) to find the maximum reading.
5. Set the test-receiver system to Peak or CISPR quasi-peak Detect Function with specified bandwidth under Maximum Hold Mode.
6. When the radiated emissions limits are expressed in terms of the average value of the emissions, and pulsed operation is employed, the measurement field strength shall be determined by averaging over one complete pulse train, including blanking intervals, as long as the pulse train does not exceed 0.1 seconds. As an alternative (provided the transmitter operates for longer than 0.1 seconds) or in cases where the pulse train exceeds 0.1 seconds, the measured field strength shall be determined from the average absolute voltage during a 0.1 second interval during which the field strength is at its maximum value.
7. In case the emission is lower than 30 MHz, loop antenna has to be used for measurement and the recorded data shall be QP measured by receiver.

3.5.5 Test Setup

For radiated test below 30MHz

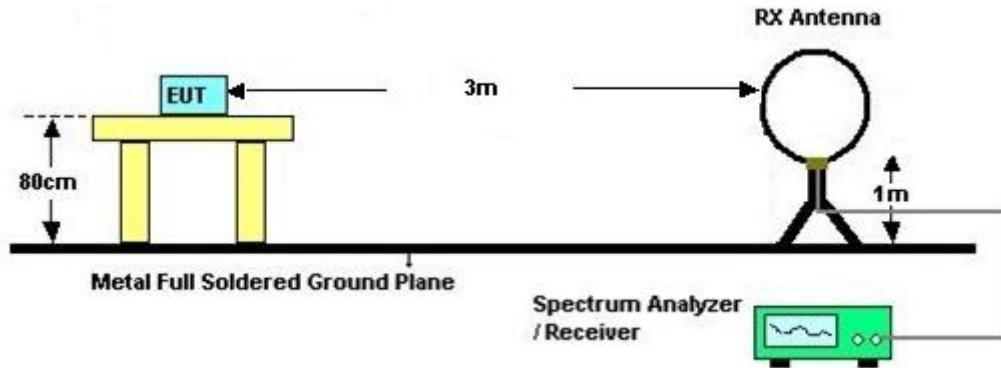

For radiated test above 30MHz

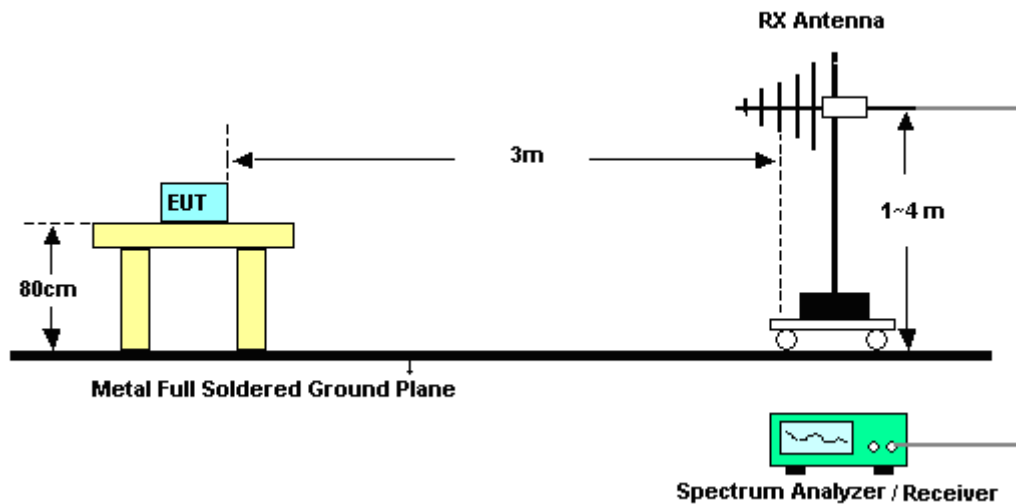

3.5.6 Test Result of Radiated Emissions Measurement

Please refer to Appendix C.

Remark:

1. There is adequate comparison measurement of both open-field test site and alternative test site - semi-Anechoic chamber according to 414788 D01 Radiated Test Site v01r01, and the result came out very similar.
2. According to C63.10 radiated Test, the EUT pre-scanned horizontal, vertical, and ground-parallel three polarization's, the worst case is horizontal & vertical polarization, test data of two mode was reported.



3.6 Antenna Requirements

3.6.1 Standard Applicable

Except for special regulations, the Low-power Radio-frequency Devices must not be equipped with any jacket for installing an antenna with extension cable. An intentional radiator shall be designed to ensure that no antenna other than that furnished by the responsible party shall be used with the device. The use of a permanently attached antenna or of an antenna that uses a unique coupling to the intentional radiator shall be considered sufficient to comply with the provisions of this Section. The manufacturer may design the unit so that the user can replace a broken antenna, but the use of a standard antenna jack or electrical connector is prohibited.

The use of a permanently attached antenna or of an antenna that uses a unique coupling to the intentional radiator shall be considered sufficient to comply with the rule.

3.6.2 Antenna Anti-Replacement Construction

An embedded-in antenna design is used.



4. List of Measuring Equipment

Instrument	Manufacturer	Model No.	Serial No.	Characteristics	Calibration Date	Test Date	Due Date	Remark
Spectrum Analyzer	R&S	FSV40	101040	10Hz~40GHz	Oct. 14, 2021	Dec. 18, 2021	Oct. 13, 2022	Conducted (TH01-KS)
Temperature & humidity chamber	Hongzhan	LP-150U	H2014011440	-40~+150°C 20%~95%RH	Jul. 12, 2021	Dec. 18, 2021	Jul. 11, 2022	Conducted (TH01-KS)
EMI Test Receiver	R&S	ESR7	101403	9kHz~7GHz;Max 30dBm	Oct. 16, 2021	Jan. 07, 2022	Oct. 15, 2022	Radiation (03CH02-KS)
Loop Antenna	R&S	HFH2-Z2	100321	9kHz~30MHz	Oct. 30, 2021	Jan. 07, 2022	Oct. 29, 2022	Radiation (03CH02-KS)
Bilog Antenna	TeseQ	CBL6111D	44483	30MHz-1GHz	Dec. 22, 2021	Jan. 07, 2022	Dec. 21, 2022	Radiation (03CH02-KS)
Amplifier	SONOMA	310N	187289	9KHz-1GHz	Apr. 12, 2021	Jan. 07, 2022	Apr. 11, 2022	Radiation (03CH02-KS)
AC Power Source	Chroma	61601	616010002473	N/A	NCR	Jan. 07, 2022	NCR	Radiation (03CH02-KS)
Turn Table	MF	MF7802	N/A	0~360 degree	NCR	Jan. 07, 2022	NCR	Radiation (03CH02-KS)
Antenna Mast	MF	MF7802	N/A	1 m~4 m	NCR	Jan. 07, 2022	NCR	Radiation (03CH02-KS)
EMI Receiver	R&S	ESCI7	100768	9kHz~7GHz;	Apr. 21, 2021	Dec. 26, 2021	Apr. 20, 2022	Conduction (CO01-KS)
AC LISN (for auxiliary equipment)	MessTec	AN3016	060103	9kHz~30MHz	Oct. 14, 2021	Dec. 26, 2021	Oct. 13, 2022	Conduction (CO01-KS)
AC LISN	R&S	ENV216	100334	9kHz~30MHz	Oct. 14, 2021	Dec. 26, 2021	Oct. 13, 2022	Conduction (CO01-KS)
AC Power Source	Chroma	61602	ABP000000811	AC 0V~300V, 45Hz~1000Hz	Oct. 14, 2021	Dec. 26, 2021	Oct. 13, 2022	Conduction (CO01-KS)

NCR: No Calibration Required



5. Uncertainty of Evaluation

Uncertainty of Conducted Emission Measurement (150 kHz ~ 30 MHz)

Measuring Uncertainty for a Level of Confidence of 95% ($U = 2Uc(y)$)	2.9dB
---	-------

Uncertainty of Radiated Emission Measurement (9 kHz ~ 30 MHz)

Measuring Uncertainty for a Level of Confidence of 95% ($U = 2Uc(y)$)	4.9dB
---	-------

Uncertainty of Radiated Emission Measurement (30 MHz ~ 1000 MHz)

Measuring Uncertainty for a Level of Confidence of 95% ($U = 2Uc(y)$)	5.0dB
---	-------



Appendix A. Test Results of Conducted Emission Test

Test Engineer :	Amos Zhang	Temperature :	25.3~26.2°C
		Relative Humidity :	38~40%
Test Voltage :	120Vac / 60Hz	Phase :	Line
Remark :	All emissions not reported here are more than 10 dB below the prescribed limit.		

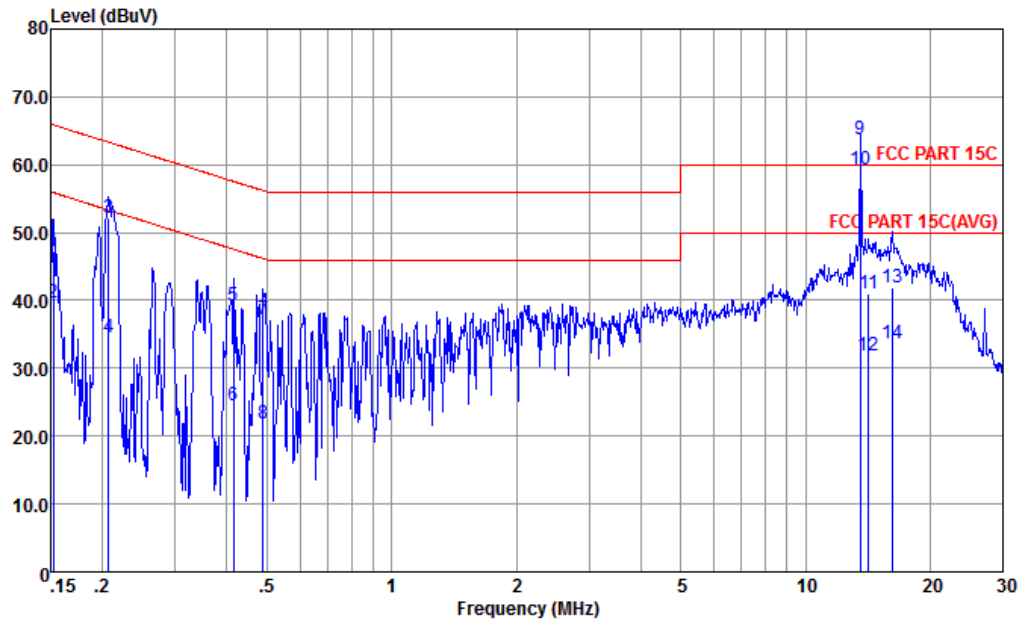

Site : CO01-KS
 Condition : FCC PART 15C LISN-060105-L LINE

	Freq	Level	Over	Limit	Read	LISN	Cable	Remark
	MHz	dBuV	Limit	Line	Level	Factor	Loss	
			dB	dBuV	dBuV	dB	dB	
1	0.152	47.29	-18.58	65.87	36.80	0.02	10.47	QP
2	0.152	39.69	-16.18	55.87	29.20	0.02	10.47	Average
3	0.207	52.20	-11.12	63.32	41.80	0.04	10.36	QP
4	0.207	34.60	-18.72	53.32	24.20	0.04	10.36	Average
5	0.415	39.15	-18.40	57.55	28.80	0.09	10.26	QP
6	0.415	24.55	-23.00	47.55	14.20	0.09	10.26	Average
7	0.489	37.14	-19.05	56.19	26.80	0.10	10.24	QP
8	0.489	21.84	-24.35	46.19	11.50	0.10	10.24	Average
9 *	13.560	63.76			53.10	0.28	10.38	QP
10 *	13.560	59.26			48.60	0.28	10.38	Average
11	14.213	40.98	-19.02	60.00	30.30	0.29	10.39	QP
12	14.213	31.78	-18.22	50.00	21.10	0.29	10.39	Average
13	16.226	41.87	-18.13	60.00	31.10	0.35	10.42	QP
14	16.226	33.67	-16.33	50.00	22.90	0.35	10.42	Average

(1) with antenna

Remark: 13.560MHz is the NFC RF fundamental signal.



Test Engineer : Amos Zhang	Temperature : 25.3~26.2°C
Test Voltage : 120Vac / 60Hz	Phase : Neutral
Remark :	All emissions not reported here are more than 10 dB below the prescribed limit.

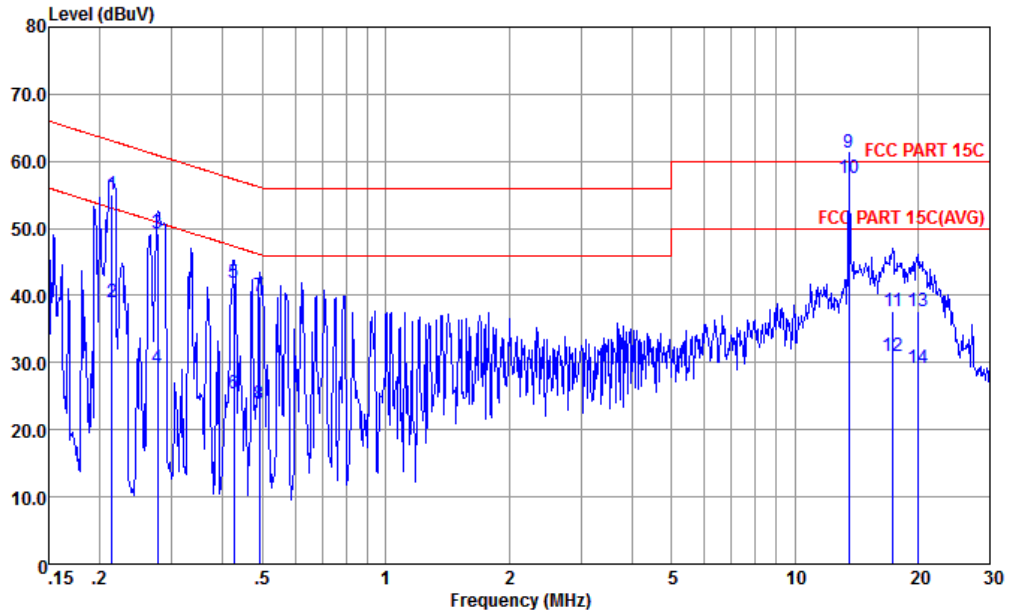

Site : CO01-KS
 Condition : FCC PART 15C LISN-060105-N NEUTRAL

	Freq	Level	Over	Limit	Read	LISN	Cable	Remark
	MHz	dBuV	Limit	Line	Level	Factor	Loss	
			dB	dBuV	dBuV	dB	dB	
1	0.214	54.95	-8.10	63.05	44.50	0.10	10.35	QP
2	0.214	39.05	-14.00	53.05	28.60	0.10	10.35	Average
3	0.277	49.32	-11.58	60.90	38.90	0.10	10.32	QP
4	0.277	29.22	-21.68	50.90	18.80	0.10	10.32	Average
5	0.426	41.86	-15.47	57.33	31.49	0.11	10.26	QP
6	0.426	25.46	-21.87	47.33	15.09	0.11	10.26	Average
7	0.491	39.85	-16.29	56.14	29.50	0.11	10.24	QP
8	0.491	23.85	-22.29	46.14	13.50	0.11	10.24	Average
9 *	13.560	61.37			50.70	0.29	10.38	QP
10 *	13.560	57.57			46.90	0.29	10.38	Average
11	17.383	37.66	-22.34	60.00	26.79	0.42	10.45	QP
12	17.383	31.06	-18.94	50.00	20.19	0.42	10.45	Average
13	20.056	37.61	-22.39	60.00	26.60	0.52	10.49	QP
14	20.056	29.21	-20.79	50.00	18.20	0.52	10.49	Average

(1) with antenna

Remark: 13.560MHz is the NFC RF fundamental signal.



Test Engineer :	Amos Zhang	Temperature :	25.3~26.2°C
		Relative Humidity :	38~40%
Test Voltage :	120Vac / 60Hz	Phase :	Line
Remark :	All emissions not reported here are more than 10 dB below the prescribed limit.		

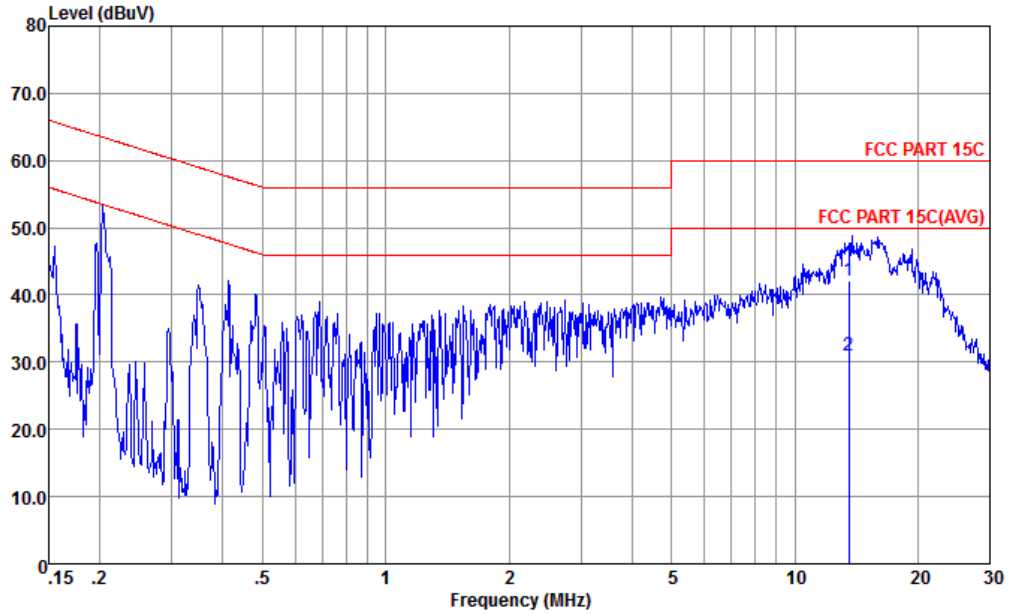

Site : CO01-KS
 Condition : FCC PART 15C LISN-060105-L LINE

	Freq	Level	Over	Limit	Read	LISN	Cable	
	MHz	dBuV	Limit	Line	Level	Factor	Loss	Remark
			dB	dBuV	dBuV	dB	dB	
1 *	13.560	42.16	-17.84	60.00	31.50	0.28	10.38	QP
2	13.560	30.96	-19.04	50.00	20.30	0.28	10.38	Average

(2) With dummy load

Remark: Only the fundamental NFC signal needs to be retested per KDB 174176.



Test Engineer :	Amos Zhang	Temperature :	25.3~26.2°C
		Relative Humidity :	38~40%
Test Voltage :	120Vac / 60Hz	Phase :	Neutral
Remark :	All emissions not reported here are more than 10 dB below the prescribed limit.		

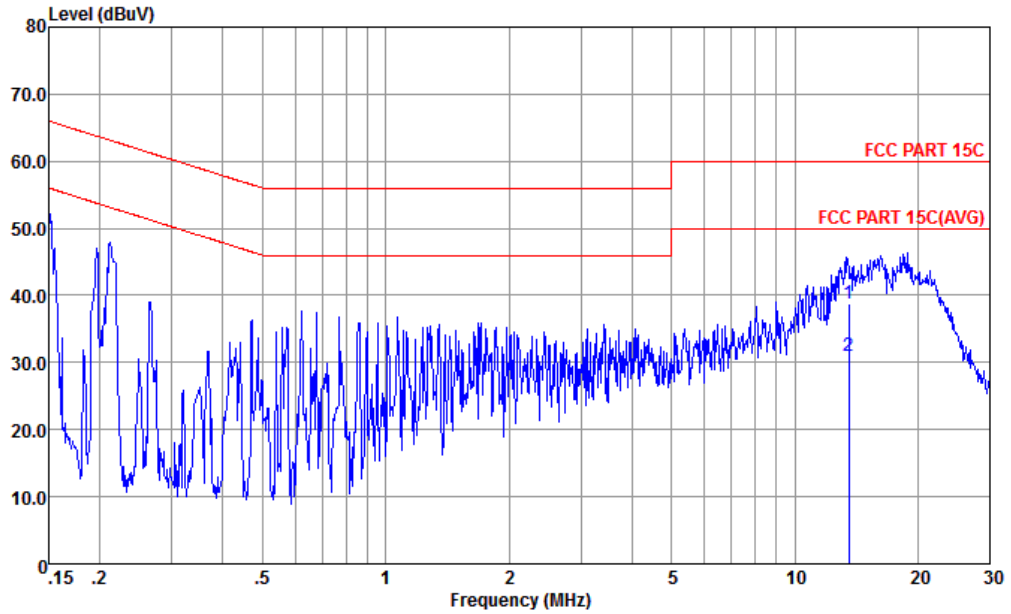

Site : CO01-KS
 Condition : FCC PART 15C LISN-060105-N NEUTRAL

	Freq	Level	Over	Limit	Read	LISN	Cable	Remark
	MHz	dBuV	Limit	Line	Level	Factor	Loss	
			dB	dBuV	dBuV	dB	dB	
1	13.551	38.87	-21.13	60.00	28.20	0.29	10.38	QP
2 *	13.551	30.97	-19.03	50.00	20.30	0.29	10.38	Average

(2) With dummy load

Remark: Only the fundamental NFC signal needs to be retested per KDB 174176.

Note:

- Level(dBμV) = Read Level(dBμV) + LISN Factor(dB) + Cable Loss(dB)
- Over Limit(dB) = Level(dBμV) – Limit Line(dBμV)



Appendix B. Test Results of Conducted Test Items

B1. Test Result of 20dB Spectrum Bandwidth

Test mode	NFC Tx	Test Frequency (MHz)	13.56
20dB Bandwidth (kHz)	2.48	99% OccupiedBW(kHz)	2.10
Frequency range (MHz)	$f_L > 13.553$	13.558683	Test Result
	$f_H < 13.567$	13.561158	Complies

Remark: Because the measured signal is CW adjusting the RBW per C63.10 would not be practical since measured bandwidth will always follow the RBW and the result will be approximately twice the RBW.



B2. Test Result of Frequency Stability

For startup

Voltage vs. Frequency Stability		Temperature vs. Frequency Stability	
Voltage (Vac)	Measurement Frequency (MHz)	Temperature (°C)	Measurement Frequency (MHz)
120	13.559921	-20	13.559921
102	13.559921	-10	13.559921
138	13.559921	0	13.559921
		10	13.559921
		20	13.559921
		30	13.559921
		40	13.559921
		50	13.559921
Max.Deviation (MHz)	-0.000080	Max.Deviation (MHz)	-0.000080
Max.Deviation (ppm)	-5.8628	Max.Deviation (ppm)	-5.8628
Limit	FS < ±100 ppm	Limit	FS < ±100 ppm
Test Result	PASS	Test Result	PASS

For 2MIN

Voltage vs. Frequency Stability		Temperature vs. Frequency Stability	
Voltage (Vac)	Measurement Frequency (MHz)	Temperature (°C)	Measurement Frequency (MHz)
120	13.559935	-20	13.559921
102	13.559906	-10	13.559914
138	13.559906	0	13.559914
		10	13.559928
		20	13.559943
		30	13.559914
		40	13.559921
		50	13.559914
Max.Deviation (MHz)	-0.000094	Max.Deviation (MHz)	-0.000087
Max.Deviation (ppm)	-6.9322	Max.Deviation (ppm)	-6.3791
Limit	FS < ±100 ppm	Limit	FS < ±100 ppm
Test Result	PASS	Test Result	PASS



For 5MIN

Voltage vs. Frequency Stability		Temperature vs. Frequency Stability	
Voltage (Vac)	Measurement Frequency (MHz)	Temperature (°C)	Measurement Frequency (MHz)
120	13.559914	-20	13.559928
102	13.559914	-10	13.559935
138	13.559914	0	13.559928
		10	13.559921
		20	13.559921
		30	13.559921
		40	13.559921
		50	13.559921
Max.Deviation (MHz)	-0.000087	Max.Deviation (MHz)	-0.000080
Max.Deviation (ppm)	-6.3791	Max.Deviation (ppm)	-5.8628
Limit	FS < ±100 ppm	Limit	FS < ±100 ppm
Test Result	PASS	Test Result	PASS

For 10MIN

Voltage vs. Frequency Stability		Temperature vs. Frequency Stability	
Voltage (Vac)	Measurement Frequency (MHz)	Temperature (°C)	Measurement Frequency (MHz)
120	13.559914	-20	13.559921
102	13.559921	-10	13.559921
138	13.559914	0	13.559921
		10	13.559921
		20	13.559914
		30	13.559914
		40	13.559914
		50	13.559914
Max.Deviation (MHz)	-0.000087	Max.Deviation (MHz)	-0.000087
Max.Deviation (ppm)	-6.3791	Max.Deviation (ppm)	-6.3791
Limit	FS < ±100 ppm	Limit	FS < ±100 ppm
Test Result	PASS	Test Result	PASS



Appendix C. Test Results of Radiated Test Items

C1. Test Result of Field Strength of Fundamental Emissions

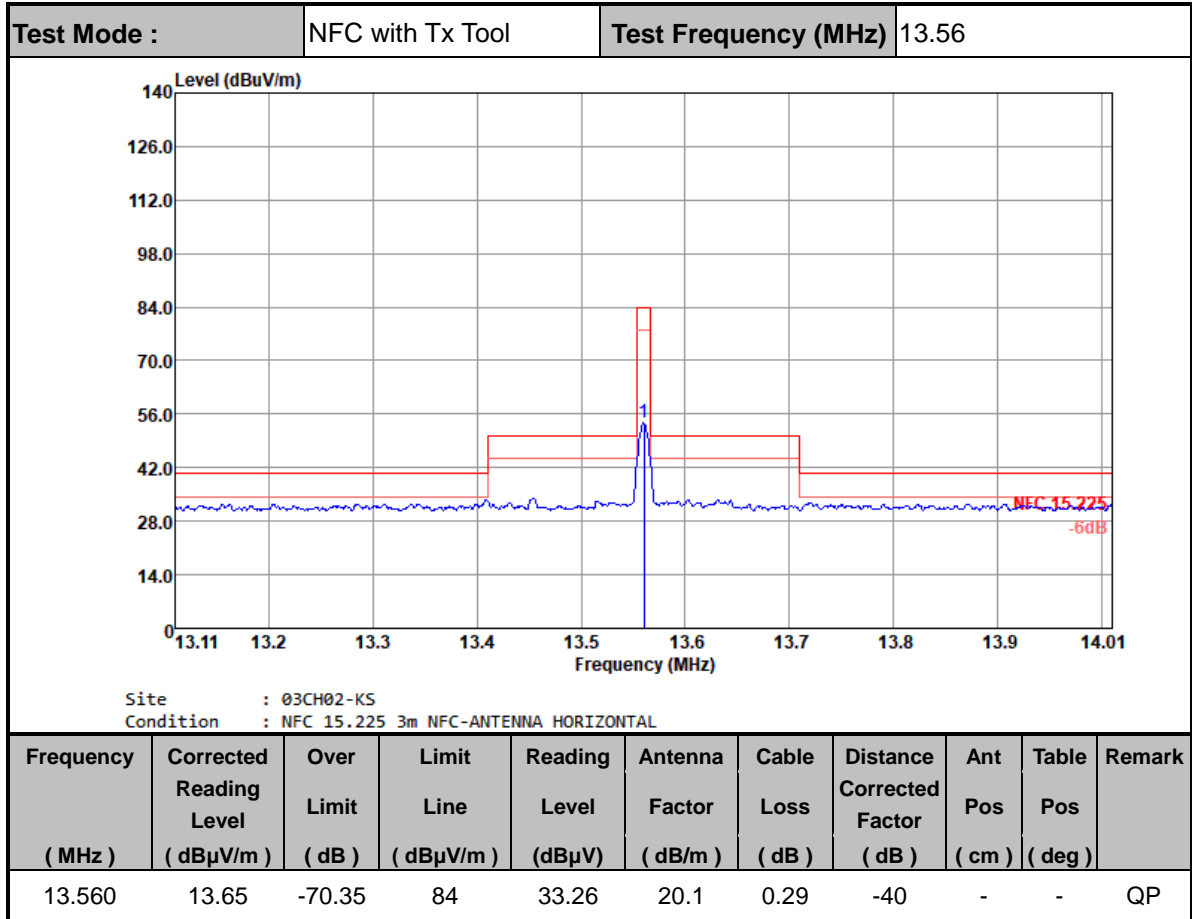

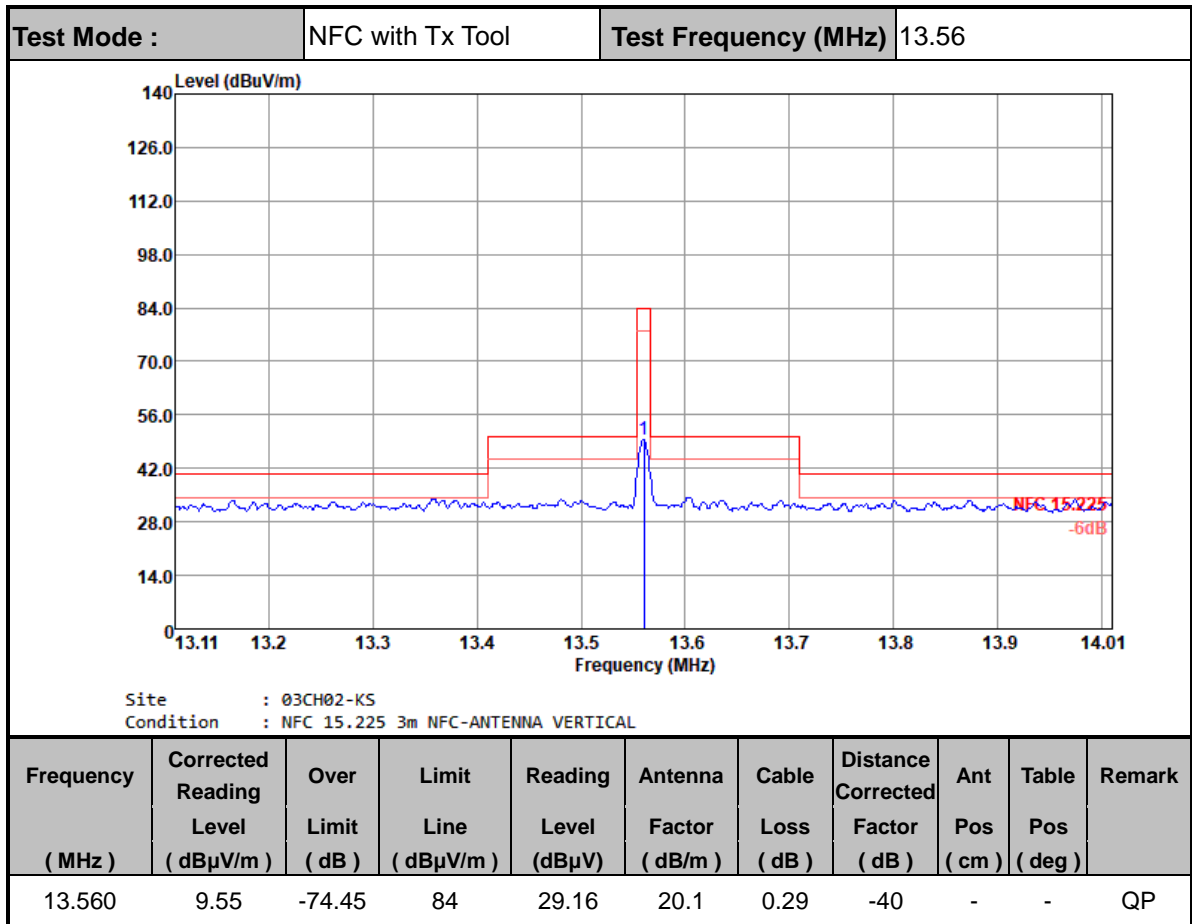

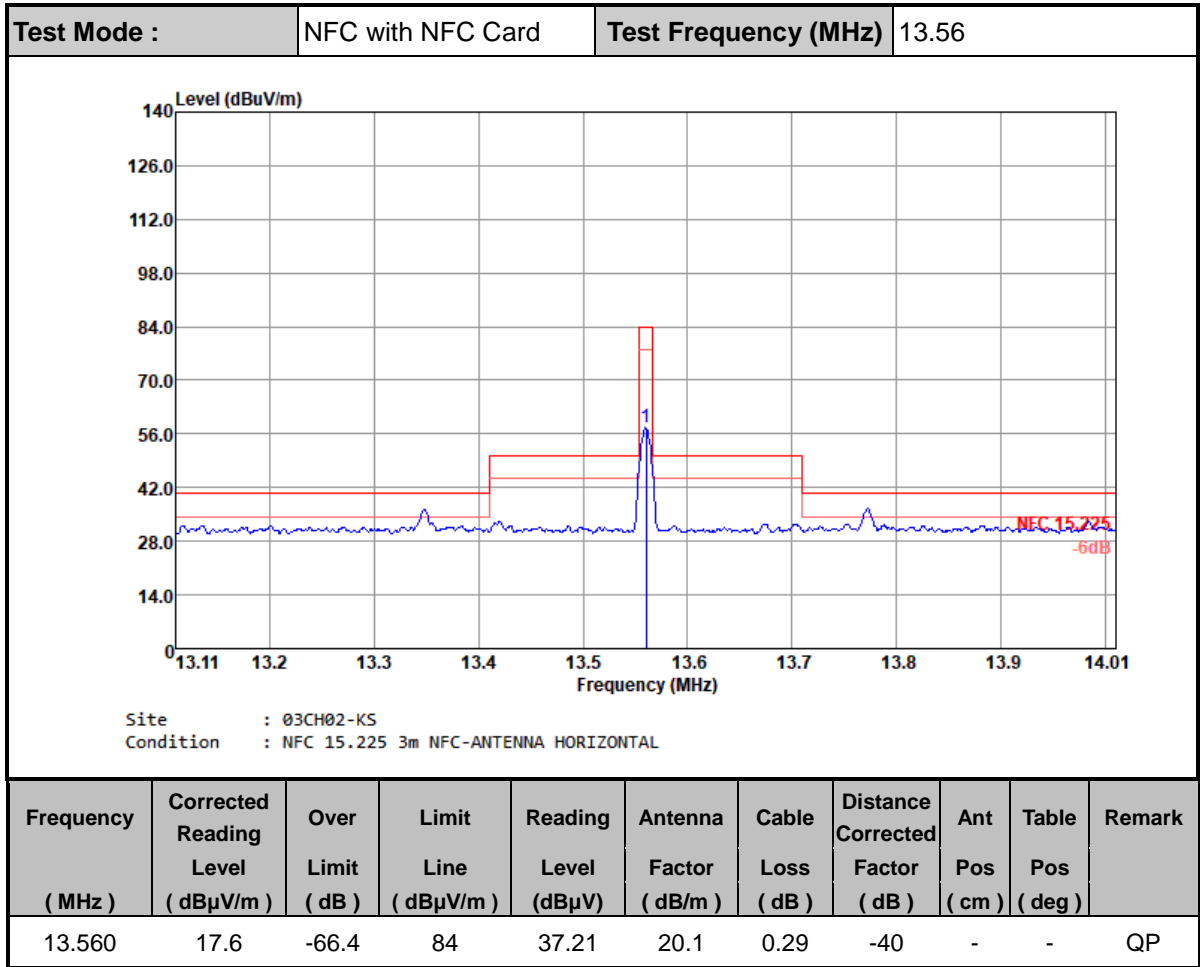

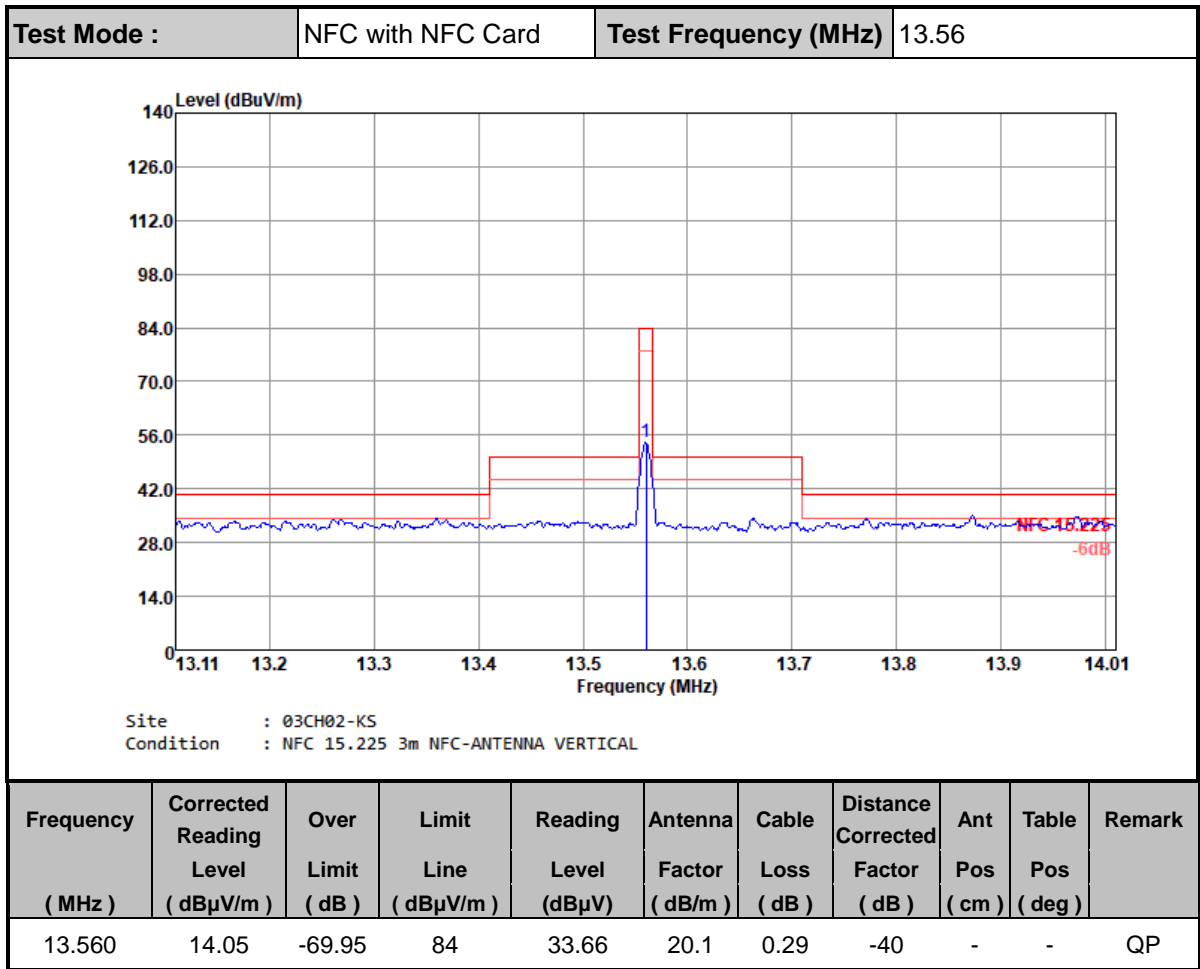

Note:

1. The amplitude of spurious emissions which are attenuated by more than 20dB below the permissible value has no need to be reported.
2. Distance extrapolation factor = 40 log (specific distance / test distance) (dB)
3. Corrected Reading Level (dBuV/m) = Measured Reading Level (dBuV) + Antenna Factor (dB/m) + Cable Loss (dB) + Distance Corrected factor
4. For 15.225 (b), (c) and (d) frequency of emission, the final test results are more than 40dB below the limit line, so the high emission frequencies are not remark.



C2. Results of Radiated Spurious Emissions (9 kHz~30MHz)

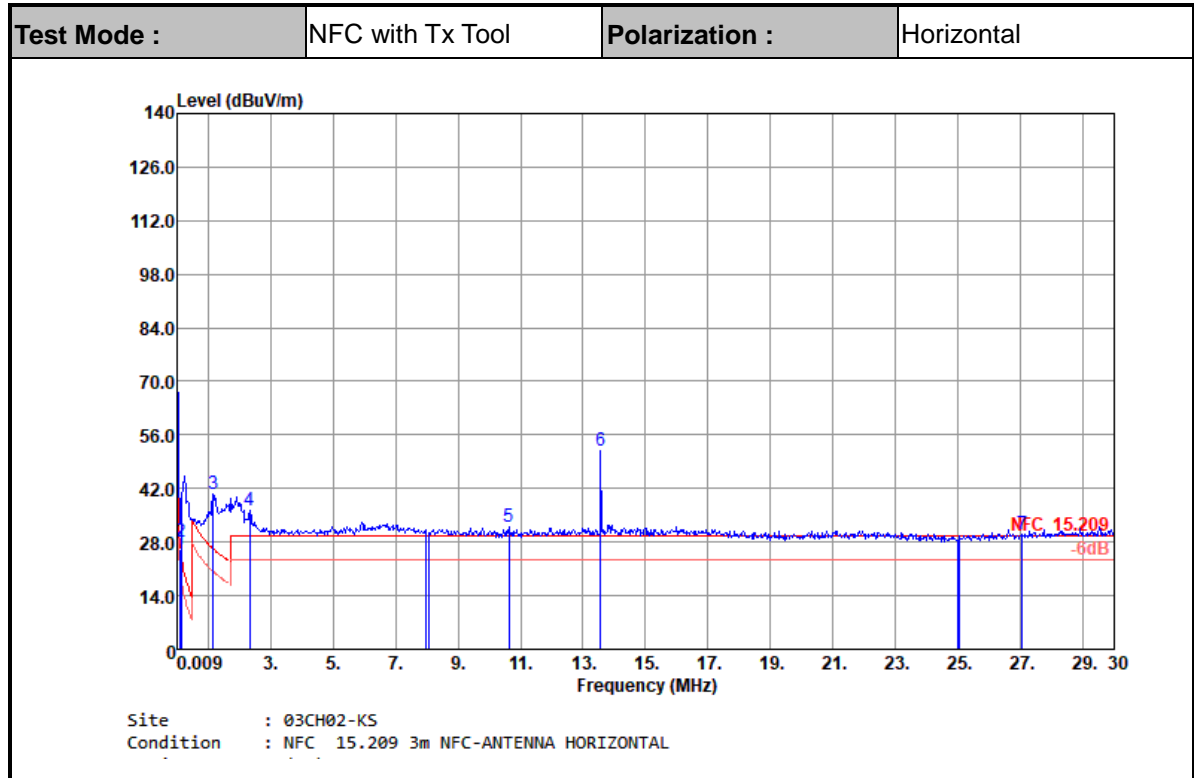

Frequency (MHz)	Corrected Reading Level (dBμV/m)	Over Limit (dB)	Limit Line (dBμV/m)	Reading Level (dBμV)	Antenna Factor (dB/m)	Cable Loss (dB)	Distance Corrected Factor (dB)	Ant Pos (cm)	Table Pos (deg)	Remark
0.11010	-53.9	-80.66	26.76	5.81	20.2	0.09	-80	-	-	Average
0.13505	-51.79	-76.77	24.98	7.85	20.27	0.09	-80	-	-	Average
1.16000	0.49	-25.81	26.3	19.57	20.82	0.1	-40	-	-	QP
2.324	-3.78	-33.32	29.54	15.29	20.82	0.11	-40	-	-	QP
10.635	-8.11	-37.65	29.54	11.38	20.26	0.25	-40	-	-	QP
13.559	11.93	-	-	31.54	20.1	0.29	-40	-	-	QP
27.055	-9.89	-39.43	29.54	10.26	19.35	0.5	-40	-	-	QP



Test Mode :	NFC with Tx Tool	Polarization :	Vertical
-------------	------------------	----------------	----------

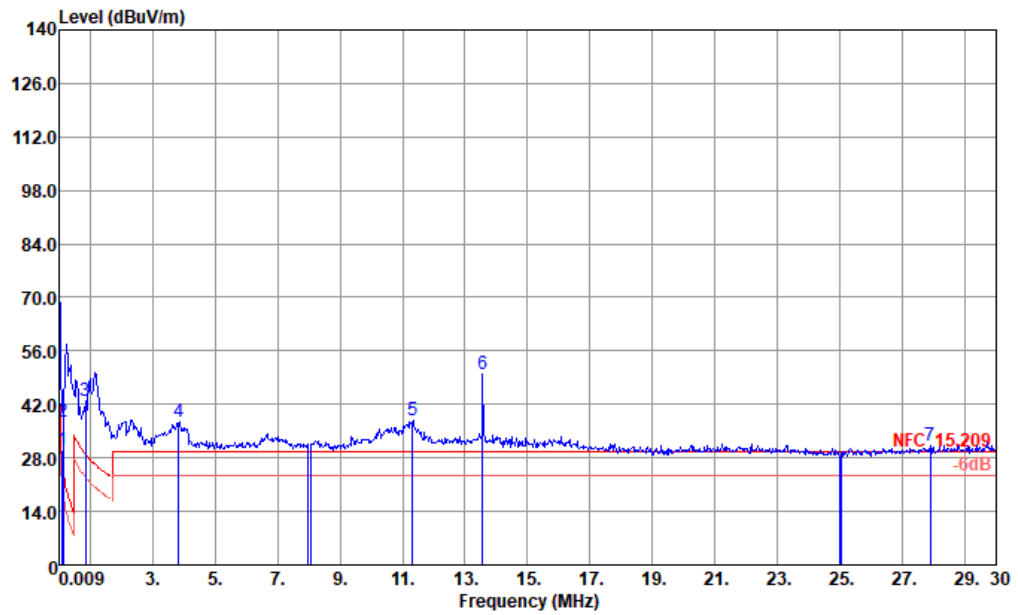

Site : 03CH02-KS
 Condition : NFC 15.209 3m NFC-ANTENNA VERTICAL

Frequency (MHz)	Corrected Reading Level (dBµV/m)	Over Limit (dB)	Limit Line (dBµV/m)	Reading Level (dBµV)	Antenna Factor (dB/m)	Cable Loss (dB)	Distance Corrected Factor (dB)	Ant Pos (cm)	Table Pos (deg)	Remark
0.12025	-49.83	-75.82	25.99	9.81	20.27	0.09	-80	-	-	Average
0.13505	-42.7	-67.68	24.98	16.94	20.27	0.09	-80	-	-	Average
0.85485	2.95	-26	28.95	22.09	20.76	0.1	-40	-	-	QP
3.842	-2.75	-32.29	29.54	16.67	20.44	0.14	-40	-	-	QP
11.315	-2.34	-31.88	29.54	17.18	20.23	0.25	-40	-	-	QP
13.559	9.98	-	-	29.59	20.1	0.29	-40	-	-	QP
27.880	-8.93	-38.47	29.54	11.11	19.44	0.52	-40	-	-	QP



Test Mode :	NFC with NFC Card	Polarization :	Horizontal
-------------	-------------------	----------------	------------

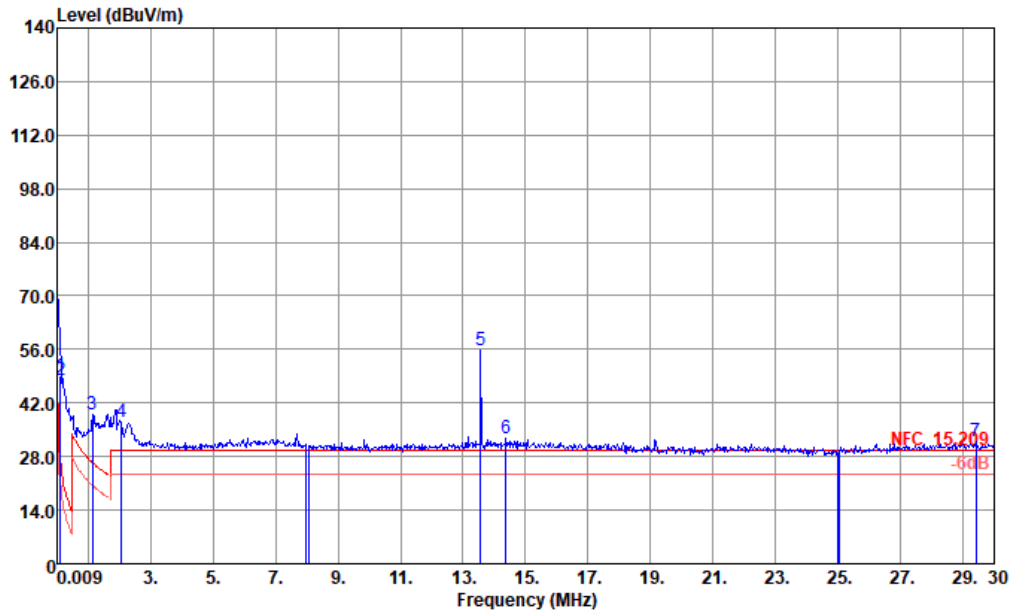

Site : 03CH02-KS
 Condition : NFC 15.209 3m NFC-ANTENNA HORIZONTAL

Frequency (MHz)	Corrected Reading Level (dBuV/m)	Over Limit (dB)	Limit Line (dBuV/m)	Reading Level (dBuV)	Antenna Factor (dB/m)	Cable Loss (dB)	Distance Corrected Factor (dB)	Ant Pos (cm)	Table Pos (deg)	Remark
0.11010	-30.79	-57.55	26.76	25.01	20.2	0.09	-80	-	-	Average
0.11348	-32.22	-58.71	26.49	22.31	20.2	0.09	-80	-	-	Average
1.145	-0.86	-27.27	26.41	29.42	20.82	0.1	-40	-	-	QP
2.078	-2.95	-32.49	29.54	19.46	20.88	0.11	-40	-	-	QP
13.559	15.76	-	-	15.25	20.1	0.29	-40	-	-	QP
14.375	-7.21	-40.84	29.54	33.63	19.88	0.29	-40	-	-	QP
29.425	-8.2	-37.74	29.54	11.3	19.63	0.53	-40	-	-	QP

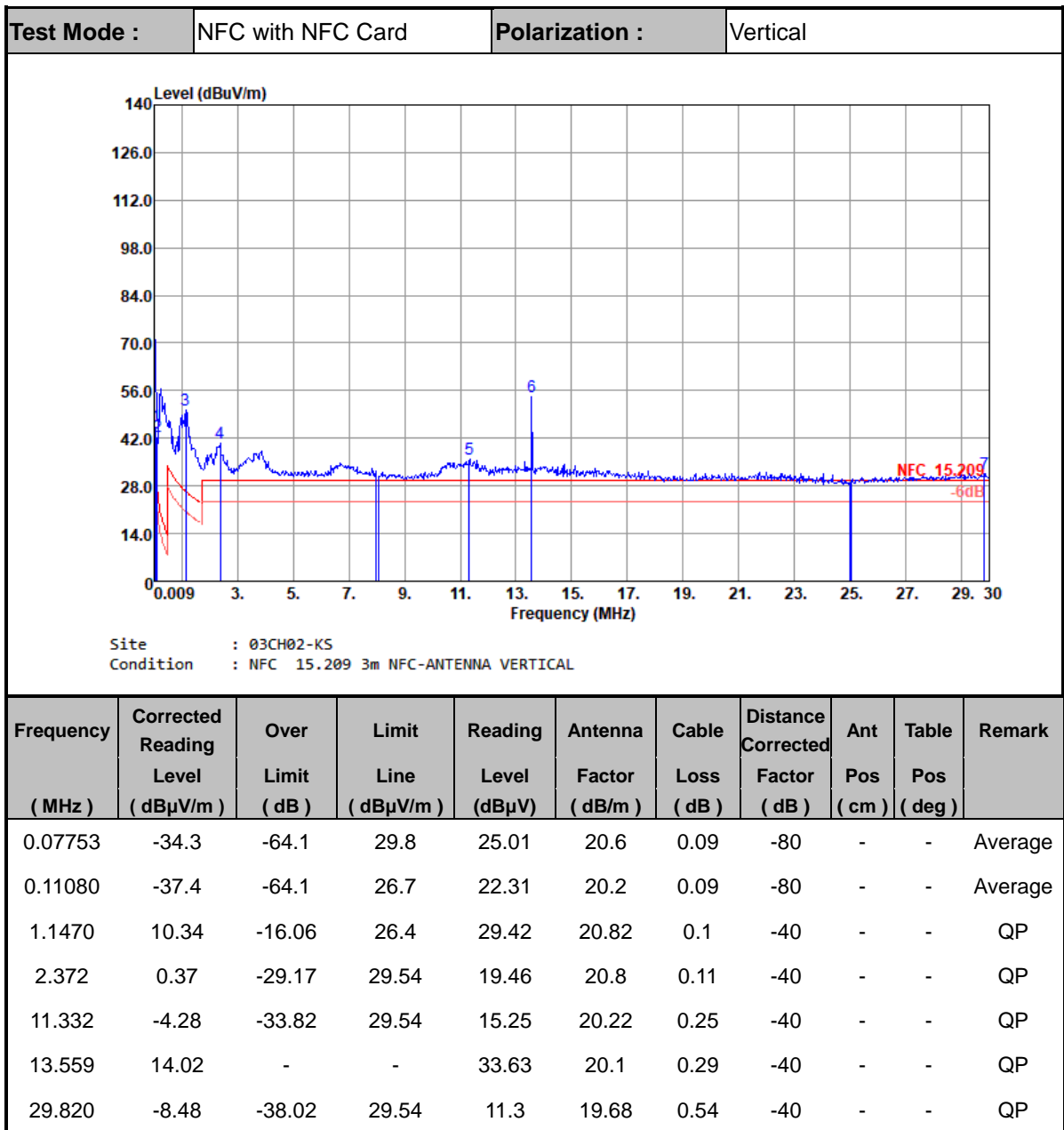

Note:

1. The amplitude of spurious emissions which are attenuated by more than 20dB below the permissible value has no need to be reported.
2. Distance extrapolation factor = 40 log (specific distance / test distance) (dB)
3. Corrected Reading Level (dBuV/m) = Measured Reading Level (dBuV) + Antenna Factor (dB/m) + Cable Loss (dB) + Distance Corrected factor
4. 13.56 MHz is fundamental signal which can be ignored



C3. Results of Radiated Spurious Emissions (30MHz~1GHz)

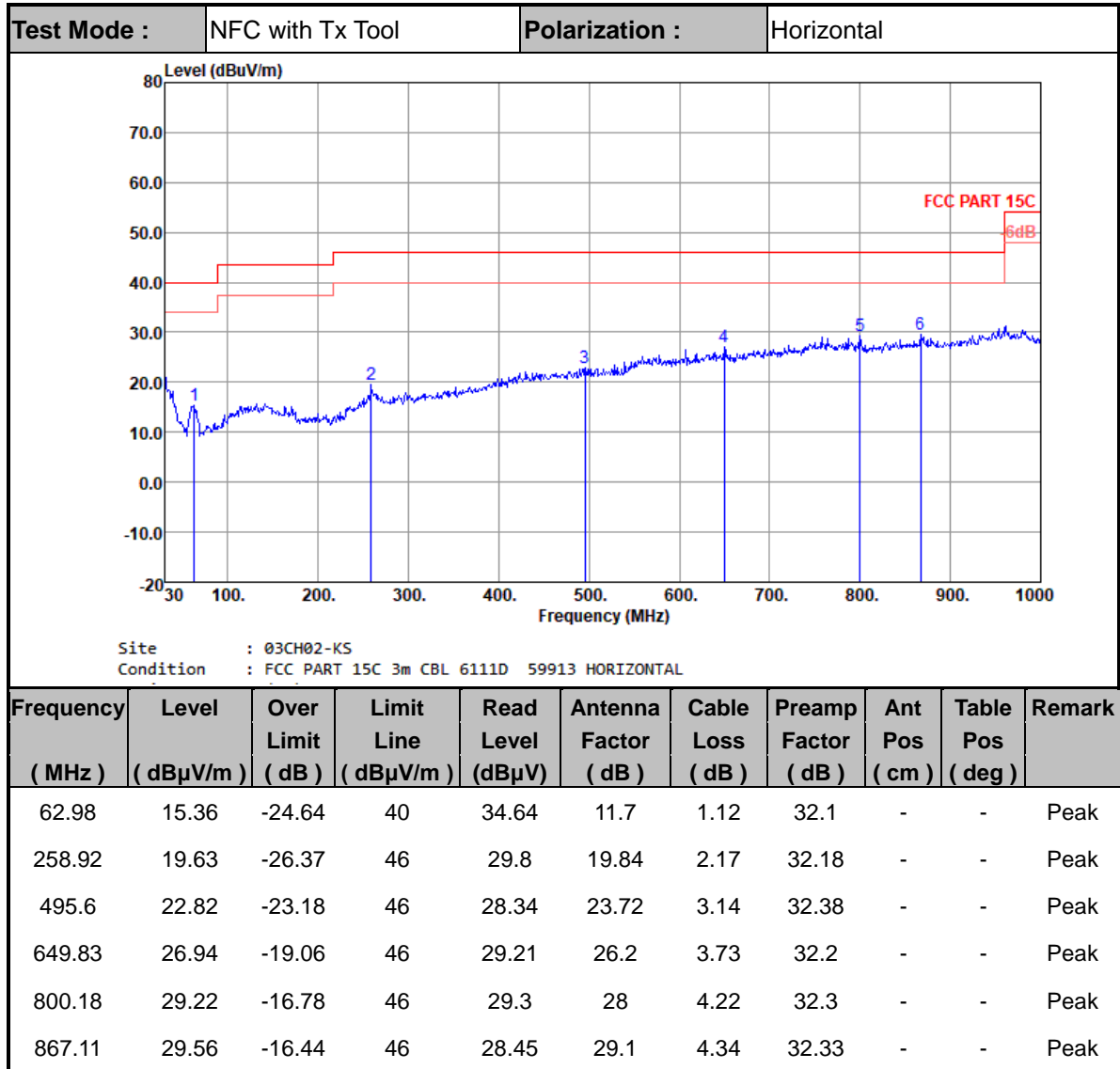



Test Mode :	NFC with Tx Tool	Polarization :	Vertical
-------------	------------------	----------------	----------

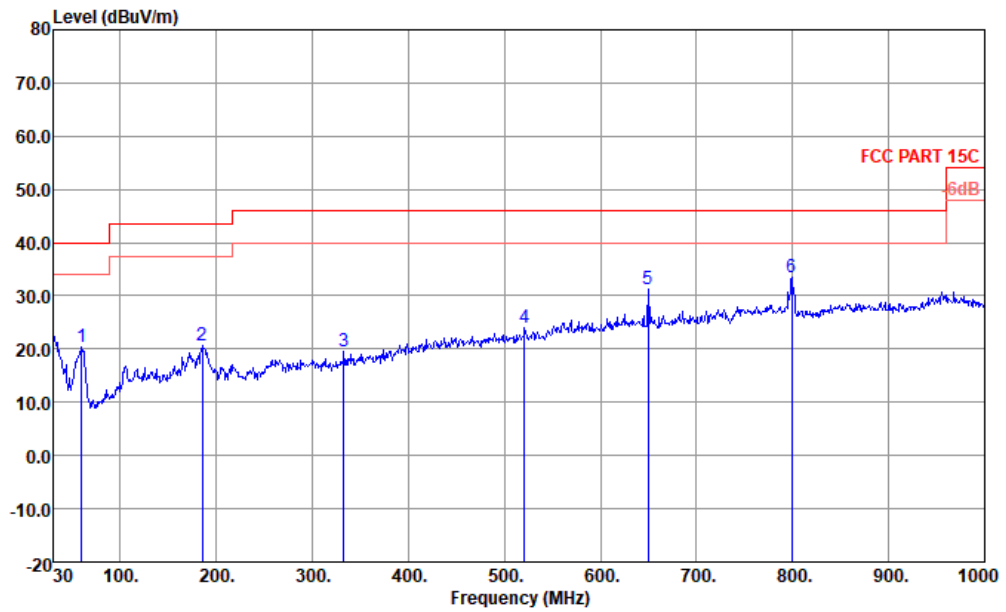

Site : 03CH02-KS
 Condition : FCC PART 15C 3m CBL 6111D 59913 VERTICAL

Frequency (MHz)	Level (dBμV/m)	Over Limit (dB)	Limit Line (dBμV/m)	Read Level (dBμV)	Antenna Factor (dB)	Cable Loss (dB)	Preamp Factor (dB)	Ant Pos (cm)	Table Pos (deg)	Remark
60.07	20.41	-19.59	40	39.64	11.8	1.07	32.1	-	-	Peak
185.2	20.68	-22.82	43.5	36.19	14.6	1.99	32.1	-	-	Peak
332.64	19.5	-26.5	46	29.25	19.72	2.69	32.16	-	-	Peak
520.82	24.1	-21.9	46	29.4	23.9	3.16	32.36	-	-	Peak
649.83	31.27	-14.73	46	33.54	26.2	3.73	32.2	-	-	Peak
799.21	33.42	-12.58	46	33.5	28	4.22	32.3	-	-	Peak



Test Mode :	NFC with NFC Card	Polarization :	Horizontal
-------------	-------------------	----------------	------------

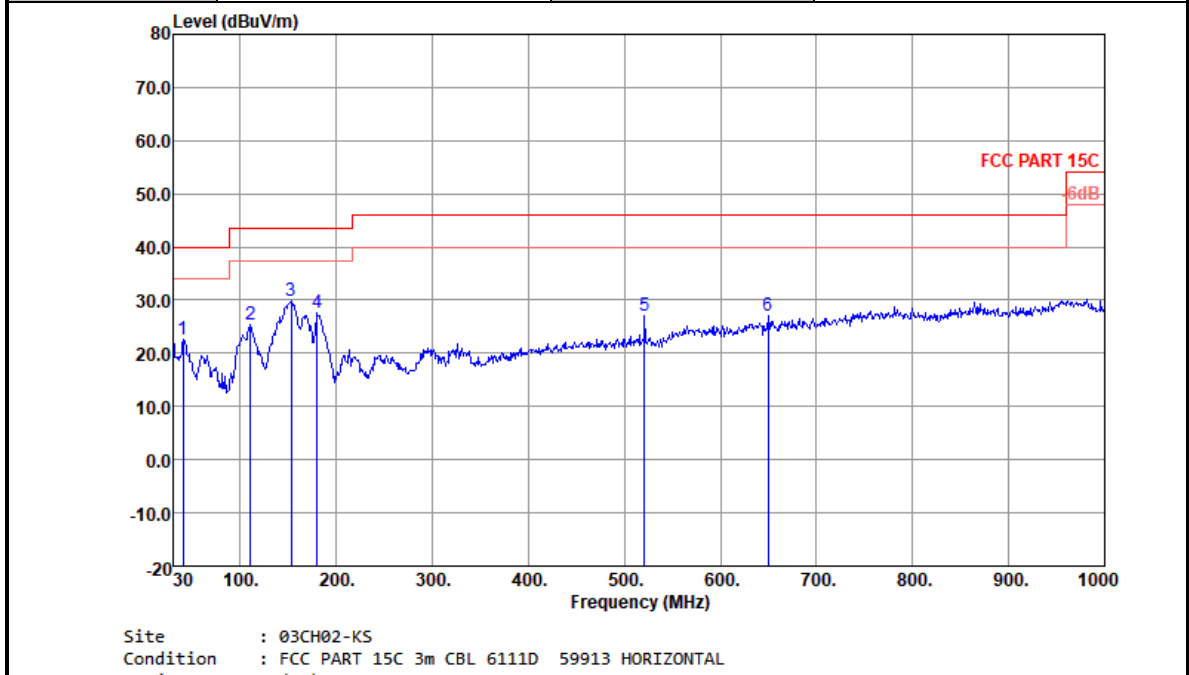

Frequency (MHz)	Level (dBμV/m)	Over Limit (dB)	Limit Line (dBμV/m)	Read Level (dBμV)	Antenna Factor (dB)	Cable Loss (dB)	Preamp Factor (dB)	Ant Pos (cm)	Table Pos (deg)	Remark
40.67	22.74	-17.26	40	35.16	18.8	0.88	32.1	-	-	Peak
110.51	25.3	-18.2	43.5	39.07	16.85	1.56	32.18	-	-	Peak
153.19	29.9	-13.6	43.5	43.49	16.7	1.81	32.1	-	-	Peak
180.35	27.74	-15.76	43.5	43.18	14.7	1.96	32.1	-	-	Peak
520.82	27.16	-18.84	46	32.46	23.9	3.16	32.36	-	-	Peak
649.83	27.08	-18.92	46	29.35	26.2	3.73	32.2	-	-	Peak

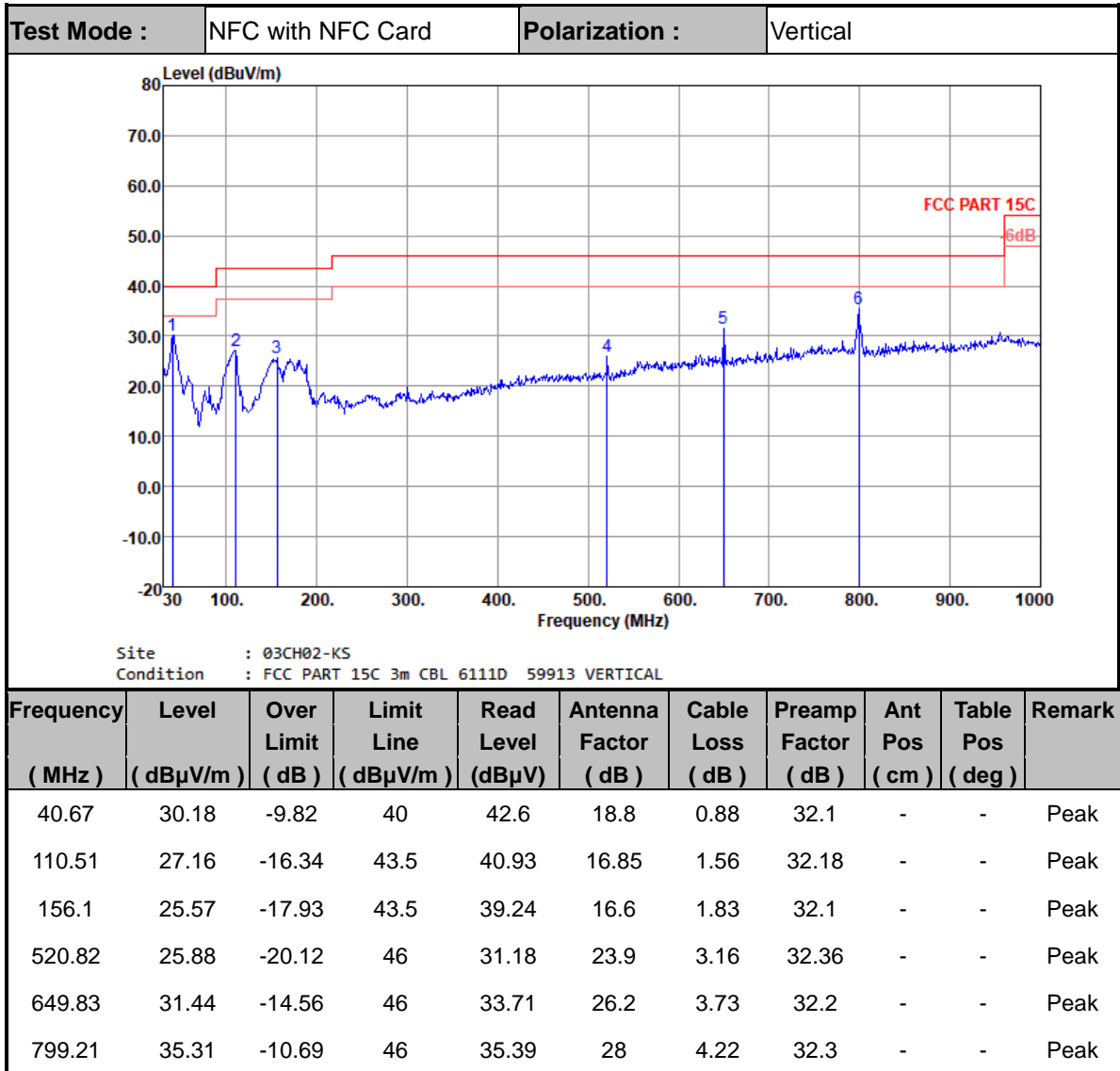

Note:

1. The amplitude of spurious emissions which are attenuated by more than 20dB below the permissible value has no need to be reported.
2. Emission level (dBμV/m) = 20 log Emission level (μV/m).
3. Corrected Reading: Antenna Factor + Cable Loss + Read Level - Preamp Factor= Level.

————THE END————