



FCC RF Test Report

APPLICANT : Sony Mobile Communications Inc.
EQUIPMENT : GSM/WCDMA/LTE Phone+Bluetooth, DTS/UNII
a/b/g/n/ac and NFC
BRAND NAME : Sony
FCC ID : PY7-57442Z
STANDARD : FCC Part 15 Subpart E §15.407
CLASSIFICATION : (NII) Unlicensed National Information Infrastructure

This is a variant report which is only valid together with the original test report. The product was received on Jun. 07, 2017 and testing was completed on Oct. 24, 2017. We, SPORTON INTERNATIONAL INC., would like to declare that the tested sample has been evaluated in accordance with the test procedures and has been in compliance with the applicable technical standards.

The test results in this report apply exclusively to the tested model / sample. Without written approval of SPORTON INTERNATIONAL INC., the test report shall not be reproduced except in full.

Reviewed by: Joseph Lin / Supervisor

Approved by: Jones Tsai / Manager



SPORTON INTERNATIONAL INC.

No. 52, Hwa Ya 1st Rd., Hwa Ya Technology Park, Kwei-Shan District, Tao Yuan City, Taiwan, R.O.C.

SPORTON INTERNATIONAL INC.

TEL : 886-3-327-3456

FAX : 886-3-328-4978

FCC ID : PY7-57442Z

Page Number : 1 of 23

Report Issued Date : Nov. 13, 2017

Report Version : Rev. 01

Report Template No.: BU5-FR15EWL Version 2.0



TABLE OF CONTENTS

REVISION HISTORY..... 3

SUMMARY OF TEST RESULT 4

1 GENERAL DESCRIPTION 5

 1.1 Applicant 5

 1.2 Manufacturer 5

 1.3 Product Feature of Equipment Under Test..... 5

 1.4 Modification of EUT 6

 1.5 Testing Location 7

 1.6 Applicable Standards 7

2 TEST CONFIGURATION OF EQUIPMENT UNDER TEST 8

 2.1 Carrier Frequency Channel 8

 2.2 Test Mode 9

 2.3 Connection Diagram of Test System 10

 2.4 EUT Operation Test Setup 10

3 TEST RESULT 11

 3.1 Maximum Conducted Output Power Measurement 11

 3.2 Unwanted Radiated Emission Measurement 13

 3.3 Automatically Discontinue Transmission 19

 3.4 Antenna Requirements 20

4 LIST OF MEASURING EQUIPMENT 21

5 UNCERTAINTY OF EVALUATION 23

APPENDIX A. CONDUCTED TEST RESULTS

APPENDIX B. RADIATED SPURIOUS EMISSION

APPENDIX C. RADIATED SPURIOUS EMISSION PLOTS

APPENDIX D. DUTY CYCLE PLOTS

APPENDIX E. ORIGINAL REPORT



SUMMARY OF TEST RESULT

Report Section	FCC Rule	Description	Limit	Result	Remark
3.1	15.407(a)	Maximum Conducted Output Power	≤ 24 dBm (depend on band)	Pass	-
3.2	15.407(b)	Unwanted Emissions	$\leq -17, -27$ dBm (depend on band)&15.209(a)	Pass	Under limit 4.80 dB at 5725.080 MHz
3.3	15.407(c)	Automatically Discontinue Transmission	Discontinue Transmission	Pass	-
3.4	15.203 & 15.407(a)	Antenna Requirement	N/A	Pass	-



1 General Description

1.1 Applicant

Sony Mobile Communications Inc.

4-12-3 Higashi-Shinagawa, Shinagawa-ku, Tokyo, 140-0002, Japan

1.2 Manufacturer

Sony Mobile Communications Inc.

4-12-3 Higashi-Shinagawa, Shinagawa-ku, Tokyo, 140-0002, Japan

1.3 Product Feature of Equipment Under Test

GSM/WCDMA/LTE, Bluetooth, DTS/UNII a/b/g/n/ac, FM Receiver, NFC, and GPS

Standards-related Product Specification	
Antenna Type	PIFA Antenna
Antenna Gain	<5150 MHz ~ 5250 MHz> -4.90 dBi
	<5250 MHz ~ 5350 MHz> -5.00 dBi
	<5470 MHz ~ 5725 MHz> -2.60 dBi

Remark: This is a variant report. All the test cases were performed on original report which can be referred to Sporton Report Number FR760710-01E.

EUT Information List			
HW Version	SW Version	S/N	Performed Test Item
A	1.14	CQ300000HS	RF conducted measurement
		CQ300004PQ	Radiated Spurious Emission



Accessory List	
AC Adapter 1	Model Name: UCH12
	S/N: 2916W46610569
Earphone 1	Model Name: MH410c
	S/N: N/A
USB Cable	Model Name: UCB20
	S/N: 1635A91C00314D8

Note:

1. Above EUT list and accessory list used are electrically identical per declared by manufacturer.
2. Above the accessories list are used to exercise the EUT during test.
3. For other wireless features of this EUT, test report will be issued separately.

1.4 Modification of EUT

No modifications are made to the EUT during all test items.



1.5 Testing Location

Sporton Lab is accredited to ISO 17025 by Taiwan Accreditation Foundation (TAF code : 1190) and the FCC designation No. TW1190 and TW0007 under the FCC 2.948(e) by Mutual Recognition Agreement (MRA) in FCC Test.

Test Site	SPORTON INTERNATIONAL INC.
Test Site Location	No. 52, Hwa Ya 1 st Rd., Hwa Ya Technology Park, Kwei-Shan District, Tao Yuan City, Taiwan, R.O.C. TEL: +886-3-327-3456 FAX: +886-3-328-4978
Test Site No.	Sporton Site No.
	TH05-HY

Note: The test site complies with ANSI C63.4 2014 requirement.

Test Site	SPORTON INTERNATIONAL INC.
Test Site Location	No.58, Aly. 75, Ln. 564, Wenhua 3rd Rd. Guishan Dist, Taoyuan City, Taiwan (R.O.C.) TEL: +886-3-327-0868 FAX: +886-3-327-0855
Test Site No.	Sporton Site No.
	03CH12-HY

Note: The test site complies with ANSI C63.4 2014 requirement.

1.6 Applicable Standards

According to the specifications of the manufacturer, the EUT must comply with the requirements of the following standards:

- ♦ FCC Part 15 Subpart E
- ♦ FCC KDB 789033 D02 General UNII Test Procedures New Rules v01r04
- ♦ ANSI C63.10-2013

Remark:

1. All test items were verified and recorded according to the standards and without any deviation during the test.
2. This EUT has also been tested and complied with the requirements of FCC Part 15, Subpart B, recorded in a separate test report.



2 Test Configuration of Equipment Under Test

- a. The EUT has been associated with peripherals and configuration operated in a manner tended to maximize its emission characteristics in a typical application. Frequency range investigated: radiated emission (9 kHz to the 10th harmonic of the highest fundamental frequency or to 40 GHz, whichever is lower). For radiated measurement, pre-scanned in three orthogonal panels, X, Y, Z. The worst cases (Z plane) were recorded in this report.

2.1 Carrier Frequency Channel

Frequency Band	Channel	Freq. (MHz)	Channel	Freq. (MHz)
5150-5250 MHz Band 1 (U-NII-1)	36	5180	44	5220
	38*	5190	46*	5230
	40	5200	48	5240
	42#	5210		

Frequency Band	Channel	Freq. (MHz)	Channel	Freq. (MHz)
5250-5350 MHz Band 2 (U-NII-2A)	52	5260	60	5300
	54*	5270	62*	5310
	56	5280	64	5320
	58#	5290		

Frequency Band	Channel	Freq. (MHz)	Channel	Freq. (MHz)
5470-5725 MHz Band 3 (U-NII-2C)	100	5500	112	5560
	102*	5510	116	5580
	104	5520	132	5660
	106#	5530	134*	5670
	108	5540	136	5680
	110*	5550	140	5700



Frequency Band	Channel	Freq. (MHz)	Channel	Freq. (MHz)
TDWR Channel	118*	5590	124	5620
	120	5600	126*	5630
	122 [#]	5610	128	5640

Frequency Band	Channel	Freq. (MHz)	Channel	Freq. (MHz)
Straddle Channel	138 [#]	5690	144	5720
	142*	5710		

Note:

1. The above Frequency and Channel in "*" were 802.11n HT40 and 802.11ac VHT40.
2. The above Frequency and Channel in "[#]" were 802.11ac VHT80.

2.2 Test Mode

Final test mode of conducted test items and radiated spurious emissions are considering the modulation and worse data rates as below table.

Modulation	Data Rate
802.11a	6 Mbps
802.11n HT20	MCS0
802.11n HT40	MCS0
802.11ac VHT20	MCS0
802.11ac VHT40	MCS0
802.11ac VHT80	MCS0

Remark: For Radiated Test Cases, The tests were performance with Battery 1.

Ch. #		Band I : 5150-5250 MHz	Band II : 5250-5350 MHz	Band III : 5470-5725MHz
		802.11a	802.11a	802.11a
L	Low	-	-	-
M	Middle	-	-	-
H	High	48	64	140
Straddle		-	-	-

2.3 Connection Diagram of Test System

<WLAN Tx Mode>

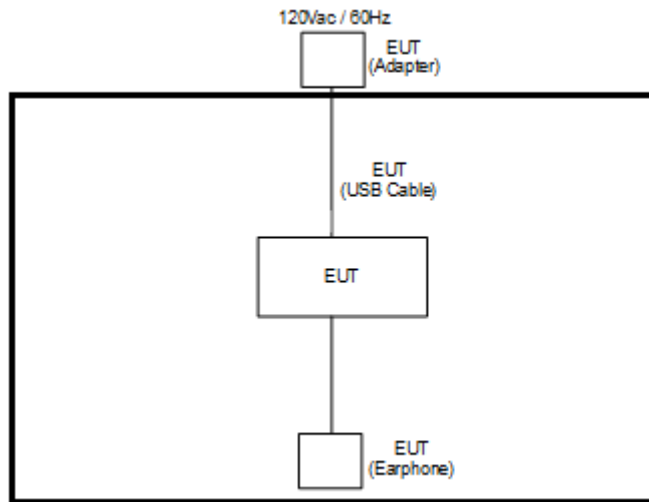

2.4 EUT Operation Test Setup

For RF test items, an engineering test program was provided and enabled to make EUT transmitting signals.



3 Test Result

3.1 Maximum Conducted Output Power Measurement

3.1.1 Limit of Maximum Conducted Output Power

<FCC 14-30 CFR 15.407>

For mobile and portable client devices in the 5.15–5.25 GHz band, the maximum conducted output power over the frequency band of operation shall not exceed 250 mW.

For the 5.25–5.725 GHz bands, the maximum conducted output power over the frequency bands of operation shall not exceed the lesser of 250 mW or 11 dBm 10 log B, where B is the 26 dB emission bandwidth in megahertz.

If transmitting antennas of directional gain greater than 6 dBi are used, the peak output power shall be reduced by the amount in dB that the directional gain of the antenna exceeds 6 dBi.

Note that U-NII-2 band, devices with a maximum e.i.r.p. greater than 500 mW shall implement TPC in order to have the capability to operate at least 6 dB below the maximum permitted e.i.r.p. of 1 W.

For Straddle Channel, According to KDB 789033 D02 General UNII Test Procedures New Rules v01r04. If the power and PSD of the devices are uniform and comply with the lower limits specified for the U-NII-2 bands, a single measurement over the entire emission bandwidth can be performed to show compliance.

3.1.2 Measuring Instruments

The measuring equipment is listed in the section 4 of this test report.

3.1.3 Test Procedures

The testing follows Method PM of FCC KDB 789033 D02 General UNII Test Procedures New Rules v01r04.

Method PM (Measurement using an RF average power meter):

1. Measurement is performed using a wideband RF power meter.
2. The EUT is configured to transmit continuously with a consistent duty cycle at its maximum power control level.
3. Measure the average power of the transmitter, and the average power is corrected with duty factor, $10 \log(1/x)$, where x is the duty cycle.

3.1.4 Test Setup

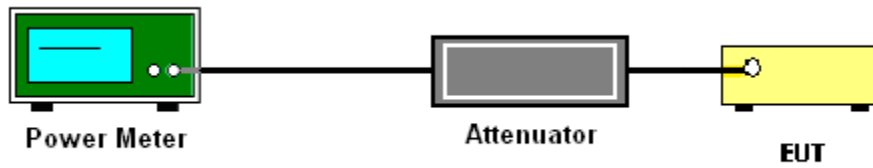

3.1.5 Test Result of Maximum Conducted Output Power

Please refer to Appendix A.



3.2 Unwanted Radiated Emission Measurement

This section is to measure unwanted emissions through radiated measurement for band edge spurious emissions and out of band emissions measurement.

3.2.1 Limit of Unwanted Emissions

- (1) For transmitters operating in the 5150-5250 MHz band: all emissions outside of the 5150-5350 MHz band shall not exceed an EIRP of -27dBm/MHz.

For transmitters operating in the 5250-5350 MHz band: all emissions outside of the 5150-5350 MHz band shall not exceed an EIRP of -27 dBm/MHz. Devices operating in the 5250-5350 MHz band that generate emissions in the 5150-5250 MHz band must meet all applicable technical requirements for operation in the 5150-5250 MHz band (including indoor use) or alternatively meet an out-of-band emission EIRP limit of -27 dBm/MHz in the 5150-5250 MHz band.

For transmitters operating in the 5470-5725MHz band: all emissions outside of the 5470-5725MHz band shall not exceed an EIRP of -27 dBm/MHz.

- (2) Unwanted spurious emissions fallen in restricted bands shall comply with the general field strength limits as below table,

Frequency (MHz)	Field Strength (microvolts/meter)	Measurement Distance (meters)
0.009 – 0.490	2400/F(kHz)	300
0.490 – 1.705	24000/F(kHz)	30
1.705 – 30.0	30	30
30 – 88	100	3
88 – 216	150	3
216 - 960	200	3
Above 960	500	3

Note: The following formula is used to convert the EIRP to field strength.

$$E = \frac{1000000\sqrt{30P}}{3} \mu V/m, \text{ where } P \text{ is the eirp (Watts)}$$



EIRP (dBm)	Field Strength at 3m (dBμV/m)
-17	78.3
- 27	68.3

(3) KDB789033 D02 v01r04 G)2)c)

- (i) Sections 15.407(b)(1) to (b)(3) specify the unwanted emission limits for the U-NII-1 and U-NII-2 bands. As specified, emissions above 1000 MHz that are outside of the restricted bands are subject to a peak emission limit of -27 dBm/MHz.³
- (ii) Section 15.407(b)(4) specifies the unwanted emission limit for the U-NII-3 band. A band emissions mask is specified in Section 15.407(b)(4)(i). The emission limits are in terms of a Peak detector. An alternative to the band emissions mask is specified in Section 15.407(b)(4)(ii). The alternative limits are based on the highest antenna gain specified in the filing. There are also marketing and importation restrictions for the devices using the alternative limit.⁴

Note 3: An out-of-band emission that complies with both the average and peak limits of Section 15.209 is not required to satisfy the -27 dBm/MHz peak emission limit.

Note 4: Only devices with antenna gains of 10 dBi or less may be approved using the emission limits specified in Section 15.247(d) till March 2, 2018; all other devices operating in this band must use the mask specified in Section 15.407(b)(4)(i).

3.2.2 Measuring Instruments

The measuring equipment is listed in the section 4 of this test report.



3.2.3 Test Procedures

1. The testing follows FCC KDB 789033 D02 General UNII Test Procedures New Rules v01r04. Section G) Unwanted emissions measurement.

(1) Procedure for Unwanted Emissions Measurements Below 1000MHz

- RBW = 120 kHz
- VBW = 300 kHz
- Detector = Peak
- Trace mode = max hold

(2) Procedure for Peak Unwanted Emissions Measurements Above 1000 MHz

- RBW = 1 MHz
- VBW \geq 3 MHz
- Detector = Peak
- Sweep time = auto
- Trace mode = max hold

(3) Procedures for Average Unwanted Emissions Measurements Above 1000MHz

- RBW = 1 MHz
- VBW = 10 Hz, when duty cycle is no less than 98 percent.
- VBW \geq 1/T, when duty cycle is less than 98 percent where T is the minimum transmission duration over which the transmitter is on and is transmitting at its maximum power control level for the tested mode of operation.

2. The EUT was placed on a turntable with 0.8 meter for frequency below 1GHz and 1.5 meter for frequency above 1GHz respectively above ground.
3. The EUT was set 3 meters from the interference receiving antenna which was mounted on the top of a variable height antenna tower.
4. The antenna is a broadband antenna and its height is adjusted between one meter and four meters above ground to find the maximum value of the field strength for both horizontal polarization and vertical polarization of the antenna.
5. For each suspected emission, the EUT was arranged to its worst case and then adjust the antenna tower (from 1 m to 4 m) and turntable (from 0 degree to 360 degrees) to find the maximum reading.
6. For testing below 1GHz, if the emission level of the EUT in peak mode was 3 dB lower than the limit specified, then peak values of EUT will be reported, otherwise, the emissions will be repeated one by one using the CISPR quasi-peak method and reported.
7. For testing above 1GHz, the emission level of the EUT in peak mode was 20dB lower than average limit (that means the emission level in average mode also complies with the limit in average mode), then peak values of EUT will be reported, otherwise, the emissions will be measured in average mode again and reported.

3.2.4 Test Setup

For radiated emissions below 30MHz

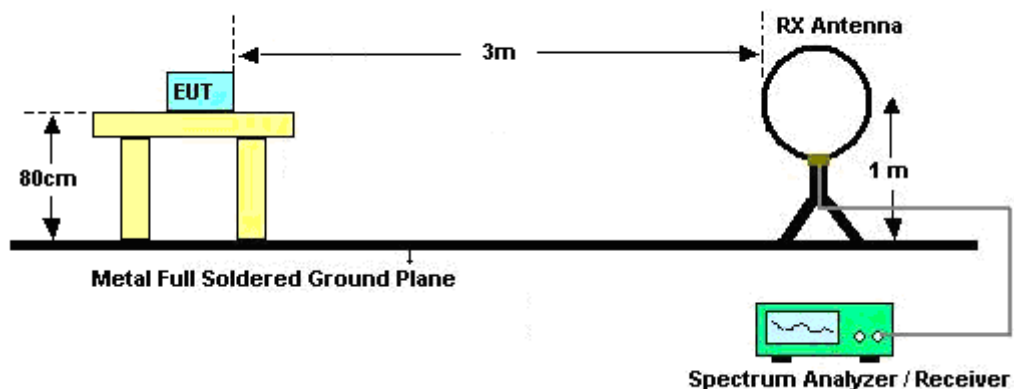

For radiated emissions from 30MHz to 1GHz

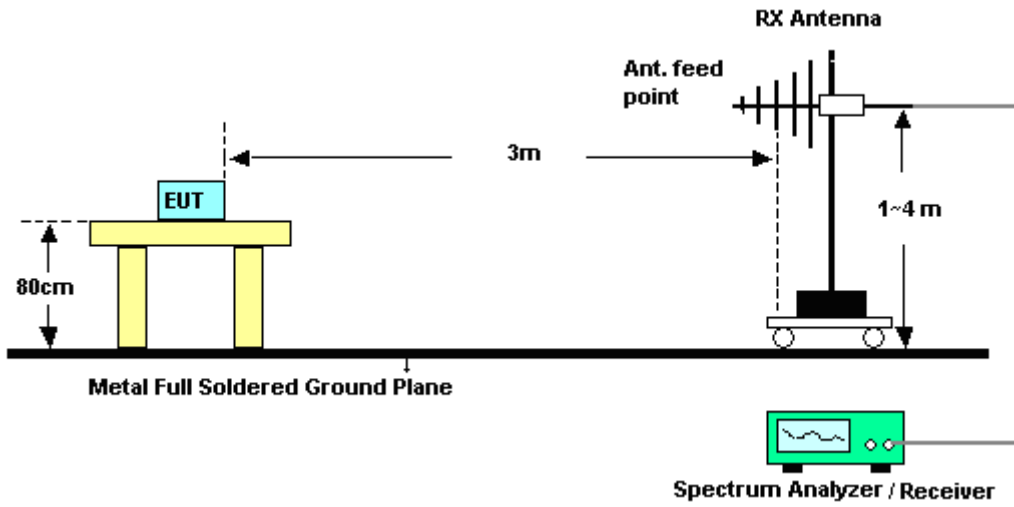

For radiated emissions above 1GHz

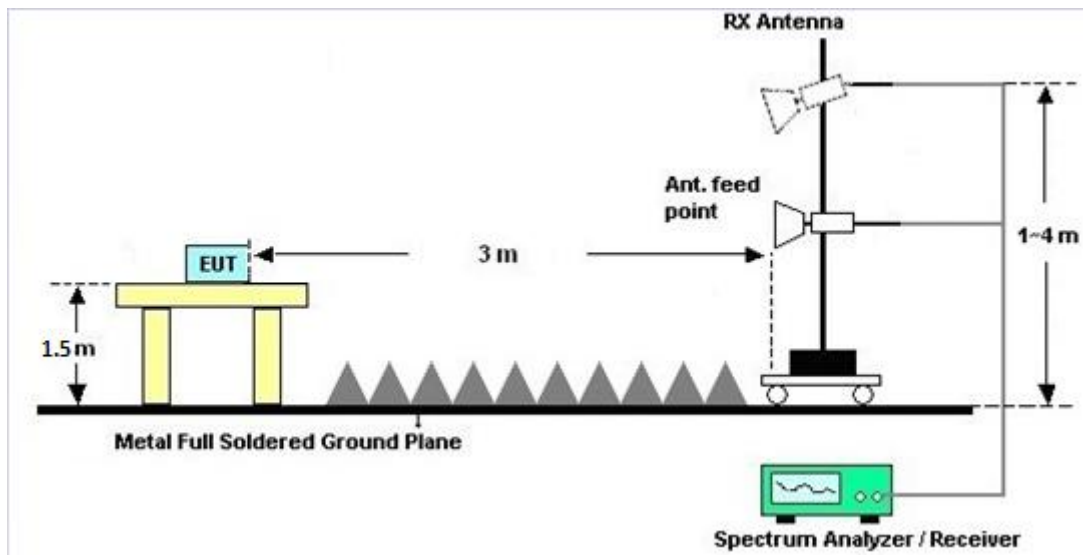



3.2.5 Test Results of Radiated Spurious Emissions (9 kHz ~ 30 MHz)

The low frequency, which started from 9 kHz to 30MHz, was pre-scanned and the result which was 20dB lower than the limit line was not reported.

There is a comparison data of both open-field test site and semi-Anechoic chamber, and the result came out very similar.

3.2.6 Test Result of Radiated Spurious at Band Edges

Please refer to Appendix B and C.

3.2.7 Duty Cycle

Please refer to Appendix D.

3.2.8 Test Result of Radiated Spurious Emissions (30MHz ~ 10th Harmonic)

Please refer to Appendix B and C.



3.3 Automatically Discontinue Transmission

3.3.1 Limit of Automatically Discontinue Transmission

The device shall automatically discontinue transmission in case of either absence of information to transmit or operational failure. These provisions are not intended to preclude the transmission of control or signaling information or the use of repetitive codes used by certain digital technologies to complete frame or burst intervals. Applicants shall include in their application for equipment authorization to describe how this requirement is met.

3.3.2 Measuring Instruments

The measuring equipment is listed in the section 4 of this test report.

3.3.3 Test Result of Automatically Discontinue Transmission

While the EUT is not transmitting any information, the EUT can automatically discontinue transmission and become standby mode for power saving. The EUT can detect the controlling signal of ACK message transmitting from remote device and verify whether it shall resend or discontinue transmission.



3.4 Antenna Requirements

3.4.1 Standard Applicable

If transmitting antenna directional gain is greater than 6 dBi, both the peak transmit power and the peak power spectral density shall be reduced by the amount in dB that the directional gain of the antenna exceeds 6 dBi.

3.4.2 Antenna Anti-Replacement Construction

An embedded-in antenna design is used.

3.4.3 Antenna Gain

The antenna gain is less than 6 dBi. Therefore, it is not necessary to reduce maximum peak output power limit.



4 List of Measuring Equipment

Instrument	Manufacturer	Model No.	Serial No.	Characteristics	Calibration Date	Test Date	Due Date	Remark
Power Meter	Anritsu	ML2495A	1218006	N/A	Oct. 06, 2016	Sep. 14, 2017~ Sep. 28, 2017	Oct. 05, 2017	Conducted (TH05-HY)
Power Sensor	Anritsu	MA2411B	1207363	300MHz~40GHz	Oct. 06, 2016	Sep. 14, 2017~ Sep. 28, 2017	Oct. 05, 2017	Conducted (TH05-HY)
Spectrum Analyzer	Rohde & Schwarz	FSP30	101067	9kHz ~ 30GHz	Nov. 17, 2016	Sep. 14, 2017~ Sep. 28, 2017	Nov. 16, 2017	Conducted (TH05-HY)
Hygrometer	TECEPEL	DTM-303B	TP157151	N/A	Mar. 20, 2017	Sep. 14, 2017~ Sep. 28, 2017	Mar. 19, 2018	Conducted (TH05-HY)
RF Cable	HUBER + SUHNER	SUCOFLEX 104	MY84209521	1GHz~26GHz	Dec. 02, 2016	Sep. 14, 2017~ Sep. 28, 2017	Dec. 01, 2017	Conducted (TH05-HY)
Loop Antenna	Rohde & Schwarz	HFH2-Z2	100488	9 kHz~30 MHz	Oct. 20, 2016	Oct. 14, 2017~ Oct. 24, 2017	Oct. 19, 2018	Radiation (03CH12-HY)
Bilog Antenna	TESEQ	CBL 6111D&00800 N1D01N-06	35413&02	30MHz~1GHz	Jan. 07, 2017	Oct. 14, 2017~ Oct. 24, 2017	Jan. 06, 2018	Radiation (03CH12-HY)
Horn Antenna	SCHWARZBECK	BBHA 9120 D	BBHA 9120 D 1212	1GHz ~ 18GHz	Mar. 17, 2017	Oct. 14, 2017~ Oct. 24, 2017	Mar. 16, 2018	Radiation (03CH12-HY)
SHF-EHF Horn Antenna	SCHWARZBECK	BBHA 9170	BBHA9170584	18GHz- 40GHz	Nov. 08, 2016	Oct. 14, 2017~ Oct. 24, 2017	Nov. 07, 2017	Radiation (03CH12-HY)
Spectrum Analyzer	Agilent	N9030A	MY52350276	3Hz~44GHz	Mar. 23, 2017	Oct. 14, 2017~ Oct. 24, 2017	Mar. 22, 2018	Radiation (03CH12-HY)
EMI Test Receiver	Rohde & Schwarz	ESU26	100390	20Hz~26.5GHz	Dec. 23, 2016	Oct. 14, 2017~ Oct. 24, 2017	Dec. 22, 2017	Radiation (03CH12-HY)
Preamplifier	COM-POWER	PA-103	161075	10MHz~1GHz	Mar. 23, 2017	Oct. 14, 2017~ Oct. 24, 2017	Mar. 22, 2018	Radiation (03CH12-HY)
Preamplifier	MITEQ	AMF-7D-0010 1800-30-10P	1815698	1GHz~18GHz	Dec. 01, 2016	Oct. 14, 2017~ Oct. 24, 2017	Nov. 30, 2017	Radiation (03CH12-HY)
Preamplifier	Keysight	83017A	MY53270148	1GHz~26.5GHz	Jan. 12, 2017	Oct. 14, 2017~ Oct. 24, 2017	Jan. 11, 2018	Radiation (03CH12-HY)
Amplifier	MITEQ	TTA1840-35-HG	1871923	18GHz~40GHz, VSWR : 2.5:1 max	Jul. 18, 2017	Oct. 14, 2017~ Oct. 24, 2017	Jul. 17, 2018	Radiation (03CH12-HY)



Instrument	Manufacturer	Model No.	Serial No.	Characteristics	Calibration Date	Test Date	Due Date	Remark
Hygrometer	TECPEL	DTM-303B	TP140349	N/A	Nov. 14, 2016	Oct. 14, 2017~ Oct. 24, 2017	Nov. 13, 2017	Radiation (03CH12-HY)
RF Cable	HUBER + SUHNER	SUCOFLEX 104	MY24958/4,M Y28653/4,MY9 839/4PE	26GHz~40GHz	Jan. 10, 2017	Oct. 14, 2017~ Oct. 24, 2017	Jan. 09, 2018	Radiation (03CH12-HY)
RF Cable	HUBER + SUHNER	SUCOFLEX 104	MY24958/4,M Y28653/4,MY9 839/4PE	1GHz~26GHz	Jan. 10, 2017	Oct. 14, 2017~ Oct. 24, 2017	Jan. 09, 2018	Radiation (03CH12-HY)
RF Cable	HUBER + SUHNER	SUCOFLEX 104	MY24958/4,M Y28653/4,MY9 839/4PE	30MHz~1GHz	Jan. 10, 2017	Oct. 14, 2017~ Oct. 24, 2017	Jan. 09, 2018	Radiation (03CH12-HY)
RF Cable	HUBER + SUHNER	SUCOFLEX 104	MY24958/4,M Y28653/4,MY9 839/4PE	9K~30MHz	Jan. 10, 2017	Oct. 14, 2017~ Oct. 24, 2017	Jan. 09, 2018	Radiation (03CH12-HY)
Controller	EMEC	EM1000	N/A	Control Turn table & Ant Mast	N/A	Oct. 14, 2017~ Oct. 24, 2017	N/A	Radiation (03CH12-HY)
Antenna Mast	EMEC	AM-BS-4500- B	N/A	1m~4m	N/A	Oct. 14, 2017~ Oct. 24, 2017	N/A	Radiation (03CH12-HY)
Turn Table	EMEC	TT2000	N/A	0~360 Degree	N/A	Oct. 14, 2017~ Oct. 24, 2017	N/A	Radiation (03CH12-HY)
Test Software	Audix	E3	6.2009-8-24	N/A	N/A	Oct. 14, 2017~ Oct. 24, 2017	N/A	Radiation (03CH12-HY)
Filter	Wainwright	WLKS1200-1 2SS	SN2	1.2G Low Pass	Mar. 24, 2017	Oct. 14, 2017~ Oct. 24, 2017	Mar. 23, 2018	Radiation (03CH12-HY)
Filter	Wainwright	WHKX12-270 0-3000-18000 -60SS	SN2	3G High Pass	Sep. 18, 2017	Oct. 14, 2017~ Oct. 24, 2017	Sep. 17, 2018	Radiation (03CH12-HY)
Filter	Woken	WHKX8-5272. 5-6750-18000 -40ST	SN2	6.75G Highpass	Mar. 22, 2017	Oct. 14, 2017~ Oct. 24, 2017	Mar. 21, 2018	Radiation (03CH12-HY)



5 Uncertainty of Evaluation

Uncertainty of Radiated Emission Measurement (30 MHz ~ 1000 MHz)

Measuring Uncertainty for a Level of Confidence of 95% ($U = 2Uc(y)$)	5.10
---	------

Uncertainty of Radiated Emission Measurement (1000 MHz ~ 18000 MHz)

Measuring Uncertainty for a Level of Confidence of 95% ($U = 2Uc(y)$)	5.20
---	------

Uncertainty of Radiated Emission Measurement (18000 MHz ~ 40000 MHz)

Measuring Uncertainty for a Level of Confidence of 95% ($U = 2Uc(y)$)	4.70
---	------

Appendix A. Test Result of Conducted Test Items

Test Engineer:	Shiming Liu	Temperature:	21~25	°C
Test Date:	2017/9/14~2017/9/28	Relative Humidity:	51~54	%

TEST RESULTS DATA
Average Power Table

FCC Band I										
Mod.	Data Rate	NTX	CH.	Freq. (MHz)	Duty Factor (dB)	Average Conducted Power (dBm)	FCC Conducted Power Limit (dBm)	DG (dBi)		Pass/Fail
11a	6Mbps	1	36	5180	0.23	16.88	24.00	-4.90		Pass
11a	6Mbps	1	44	5220	0.23	16.85	24.00	-4.90		Pass
11a	6Mbps	1	48	5240	0.23	16.84	24.00	-4.90		Pass
HT20	MCS0	1	36	5180	0.25	13.90	24.00	-4.90		Pass
HT20	MCS0	1	44	5220	0.25	13.72	24.00	-4.90		Pass
HT20	MCS0	1	48	5240	0.25	13.70	24.00	-4.90		Pass
HT40	MCS0	1	38	5190	0.39	12.84	24.00	-4.90		Pass
HT40	MCS0	1	46	5230	0.39	12.71	24.00	-4.90		Pass
VHT20	MCS0	1	36	5180	0.22	13.87	24.00	-4.90		Pass
VHT20	MCS0	1	44	5220	0.22	13.69	24.00	-4.90		Pass
VHT20	MCS0	1	48	5240	0.22	13.67	24.00	-4.90		Pass
VHT40	MCS0	1	38	5190	0.44	12.83	24.00	-4.90		Pass
VHT40	MCS0	1	46	5230	0.44	12.69	24.00	-4.90		Pass
VHT80	MCS0	1	42	5210	0.48	11.69	24.00	-4.90		Pass

TEST RESULTS DATA
Average Power Table

FCC Band II										
Mod.	Data Rate	NTX	CH.	Freq. (MHz)	Duty Factor (dB)	Average Conducted Power (dBm)	FCC Conducted Power Limit (dBm)	DG (dBi)	EIRP Power Limit (dBm)	Pass/Fail
11a	6M bps	1	52	5260	0.23	16.78	23.98	-5.00	26.99	Pass
11a	6M bps	1	60	5300	0.23	16.80	23.98	-5.00	26.99	Pass
11a	6M bps	1	64	5320	0.23	16.83	23.98	-5.00	26.99	Pass
HT20	MCS 0	1	52	5260	0.25	13.71	23.98	-5.00	26.99	Pass
HT20	MCS 0	1	60	5300	0.25	13.73	23.98	-5.00	26.99	Pass
HT20	MCS 0	1	64	5320	0.25	13.76	23.98	-5.00	26.99	Pass
HT40	MCS 0	1	54	5270	0.39	12.79	23.98	-5.00	26.99	Pass
HT40	MCS 0	1	62	5310	0.39	12.70	23.98	-5.00	26.99	Pass
VHT20	MCS 0	1	52	5260	0.22	13.68	23.98	-5.00	26.99	Pass
VHT20	MCS 0	1	60	5300	0.22	13.70	23.98	-5.00	26.99	Pass
VHT20	MCS 0	1	64	5320	0.22	13.73	23.98	-5.00	26.99	Pass
VHT40	MCS 0	1	54	5270	0.44	12.74	23.98	-5.00	26.99	Pass
VHT40	MCS 0	1	62	5310	0.44	12.69	23.98	-5.00	26.99	Pass
VHT80	MCS 0	1	58	5290	0.48	11.87	23.98	-5.00	26.99	Pass

TEST RESULTS DATA
Average Power Table

FCC Band III										
Mod.	Data Rate	NTX	CH.	Freq. (MHz)	Duty Factor (dB)	Average Conducted Power (dBm)	FCC Conducted Power Limit (dBm)	DG (dBi)	EIRP Power Limit (dBm)	Pass/Fail
11a	6M bps	1	100	5500	0.23	16.79	23.98	-2.60	26.99	Pass
11a	6M bps	1	116	5580	0.23	16.68	23.98	-2.60	26.99	Pass
11a	6M bps	1	140	5700	0.23	16.63	23.98	-2.60	26.99	Pass
11a	6M bps	1	144	5720	0.23	16.61	23.98	-2.60	26.99	Pass
HT20	MCS 0	1	100	5500	0.25	13.95	23.98	-2.60	26.99	Pass
HT20	MCS 0	1	116	5580	0.25	13.81	23.98	-2.60	26.99	Pass
HT20	MCS 0	1	140	5700	0.25	13.74	23.98	-2.60	26.99	Pass
HT20	MCS 0	1	144	5720	0.25	13.65	23.98	-2.60	26.99	Pass
HT40	MCS 0	1	102	5510	0.39	12.89	23.98	-2.60	26.99	Pass
HT40	MCS 0	1	110	5550	0.39	12.85	23.98	-2.60	26.99	Pass
HT40	MCS 0	1	134	5670	0.39	12.65	23.98	-2.60	26.99	Pass
HT40	MCS 0	1	142	5710	0.39	12.63	23.98	-2.60	26.99	Pass
VHT20	MCS 0	1	100	5500	0.22	13.92	23.98	-2.60	26.99	Pass
VHT20	MCS 0	1	116	5580	0.22	13.78	23.98	-2.60	26.99	Pass
VHT20	MCS 0	1	140	5700	0.22	13.71	23.98	-2.60	26.99	Pass
VHT20	MCS 0	1	144	5720	0.22	13.62	23.98	-2.60	26.99	Pass
VHT40	MCS 0	1	102	5510	0.44	12.86	23.98	-2.60	26.99	Pass
VHT40	MCS 0	1	110	5550	0.44	12.84	23.98	-2.60	26.99	Pass
VHT40	MCS 0	1	134	5670	0.44	12.64	23.98	-2.60	26.99	Pass
VHT40	MCS 0	1	142	5710	0.44	12.56	23.98	-2.60	26.99	Pass
VHT80	MCS 0	1	106	5530	0.48	11.83	23.98	-2.60	26.99	Pass
VHT80	MCS 0	1	122	5610	0.48	11.93	23.98	-2.60	26.99	Pass
VHT80	MCS 0	1	138	5690	0.48	11.63	23.98	-2.60	26.99	Pass



Appendix B. Radiated Spurious Emission

Test Engineer :	Nick Yu / Ray Chen	Temperature :	23~25°C
		Relative Humidity :	61~63%

Band 1 - 5150~5250MHz

WIFI 802.11a (Band Edge @ 3m)

WIFI Ant. 1	Note	Frequency (MHz)	Level (dBμV/m)	Over Limit (dB)	Limit Line (dBμV/m)	Read Level (dBμV)	Antenna Factor (dB/m)	Cable Loss (dB)	Preamp Factor (dB)	Ant Pos (cm)	Table Pos (deg)	Peak Avg. (P/A)	Pol. (H/V)
802.11a CH 48 5240MHz		5116.48	54.61	-19.39	74	47.11	32.48	5.97	30.95	119	118	P	H
		5144.82	43.43	-10.57	54	35.92	32.47	5.99	30.95	119	118	A	H
	*	5240	104.3	-	-	96.75	32.45	6.05	30.95	119	118	P	H
	*	5240	93.14	-	-	85.59	32.45	6.05	30.95	119	118	A	H
		5433.4	54.61	-19.39	74	46.96	32.41	6.19	30.95	119	118	P	H
		5396.44	43.48	-10.52	54	35.85	32.42	6.16	30.95	119	118	A	H
		5033.02	54.86	-19.14	74	47.42	32.49	5.9	30.95	117	18	P	V
		5148.72	43.43	-10.57	54	35.92	32.47	5.99	30.95	117	18	A	V
	*	5240	106.65	-	-	99.1	32.45	6.05	30.95	117	18	P	V
	*	5240	95.62	-	-	88.07	32.45	6.05	30.95	117	18	A	V
		5411.84	54.49	-19.51	74	46.86	32.42	6.16	30.95	117	18	P	V
		5458.6	43.69	-10.31	54	36.02	32.41	6.21	30.95	117	18	A	V

Remark	<ol style="list-style-type: none"> No other spurious found. All results are PASS against Peak and Average limit line.
--------	---



Band 1 5150~5250MHz

WIFI 802.11a (Harmonic @ 3m)

WIFI Ant. 1	Note	Frequency (MHz)	Level (dBμV/m)	Over Limit (dB)	Limit Line (dBμV/m)	Read Level (dBμV)	Antenna Factor (dB/m)	Cable Loss (dB)	Preamp Factor (dB)	Ant Pos (cm)	Table Pos (deg)	Peak Avg. (P/A)	Pol. (H/V)
802.11a CH 48 5240MHz		10480	47.95	-26.05	74	55.07	39.96	9.31	56.93	100	0	P	H
		15720	46.08	-27.92	74	52.75	38.84	11.56	57.81	100	0	P	H
													H
													H
		10480	48.07	-25.93	74	55.19	39.96	9.31	56.93	100	0	P	V
		15720	46.61	-27.39	74	53.28	38.84	11.56	57.81	100	0	P	V
													V
													V
Remark	1. No other spurious found. 2. All results are PASS against Peak and Average limit line.												



Band 2 - 5250~5350MHz
WiFi 802.11a (Band Edge @ 3m)

WiFi	Note	Frequency	Level	Over	Limit	Read	Antenna	Cable	Preamp	Ant	Table	Peak	Pol.
Ant.				Limit	Line	Level	Factor	Loss	Factor	Pos	Pos	Avg.	
1		(MHz)	(dBμV/m)	(dB)	(dBμV/m)	(dBμV)	(dB/m)	(dB)	(dB)	(cm)	(deg)	(P/A)	(H/V)
802.11a CH 64 5320MHz	*	5320	106.85	-	-	99.26	32.44	6.1	30.95	108	118	P	H
	*	5320	95.93	-	-	88.34	32.44	6.1	30.95	108	118	A	H
		5350.72	57.87	-16.13	74	50.27	32.43	6.12	30.95	108	118	P	H
		5354.08	44.7	-9.3	54	37.1	32.43	6.12	30.95	108	118	A	H
													H
													H
	*	5320	107.95	-	-	100.36	32.44	6.1	30.95	114	19	P	V
	*	5320	96.77	-	-	89.18	32.44	6.1	30.95	114	19	A	V
		5353.44	57.93	-16.07	74	50.33	32.43	6.12	30.95	114	19	P	V
		5350.72	44.59	-9.41	54	36.99	32.43	6.12	30.95	114	19	A	V
													V
													V
Remark	1. No other spurious found. 2. All results are PASS against Peak and Average limit line.												



Band 2 5250~5350MHz

WIFI 802.11a (Harmonic @ 3m)

WIFI Ant. 1	Note	Frequency (MHz)	Level (dBμV/m)	Over Limit (dB)	Limit Line (dBμV/m)	Read Level (dBμV)	Antenna Factor (dB/m)	Cable Loss (dB)	Preamp Factor (dB)	Ant Pos (cm)	Table Pos (deg)	Peak Avg. (P/A)	Pol. (H/V)	
802.11a CH 64 5320MHz		10640	47.16	-26.84	74	54.06	40.06	9.38	56.87	100	0	P	H	
		15960	45.81	-28.19	74	52.59	38.12	11.66	57.28	100	0	P	H	
													H	
													H	
			10640	48	-26	74	54.9	40.06	9.38	56.87	100	0	P	V
			15960	45.43	-28.57	74	52.21	38.12	11.66	57.28	100	0	P	V
														V
														V
Remark	1. No other spurious found. 2. All results are PASS against Peak and Average limit line.													



Band 3 - 5470~5725MHz
WiFi 802.11a (Band Edge @ 3m)

WiFi	Note	Frequency	Level	Over	Limit	Read	Antenna	Cable	Preamp	Ant	Table	Peak	Pol.
Ant.				Limit	Line	Level	Factor	Loss	Factor	Pos	Pos	Avg.	
1		(MHz)	(dBμV/m)	(dB)	(dBμV/m)	(dBμV)	(dB/m)	(dB)	(dB)	(cm)	(deg)	(P/A)	(H/V)
802.11a CH 140 5700MHz	*	5700	109.4	-	-	101.09	32.96	6.36	31.01	100	289	P	H
	*	5700	98.38	-	-	90.07	32.96	6.36	31.01	100	289	A	H
		5725.08	62.67	-11.33	74	54.29	33.03	6.37	31.02	100	289	P	H
		5725.08	49.2	-4.8	54	40.82	33.03	6.37	31.02	100	289	A	H
													H
													H
	*	5700	104.77	-	-	96.46	32.96	6.36	31.01	100	43	P	V
	*	5700	93.71	-	-	85.4	32.96	6.36	31.01	100	43	A	V
		5725.64	57.83	-16.17	74	49.45	33.03	6.37	31.02	100	43	P	V
		5725	46.24	-7.76	54	37.86	33.03	6.37	31.02	100	43	A	V
													V
													V
Remark	1. No other spurious found. 2. All results are PASS against Peak and Average limit line.												



Band 3 - 5470~5725MHz
WIFI 802.11a (Harmonic @ 3m)

WIFI Ant. 1	Note	Frequency (MHz)	Level (dBμV/m)	Over Limit (dB)	Limit Line (dBμV/m)	Read Level (dBμV)	Antenna Factor (dB/m)	Cable Loss (dB)	Preamp Factor (dB)	Ant Pos (cm)	Table Pos (deg)	Peak Avg. (P/A)	Pol. (H/V)
802.11a CH 140 5700MHz		11400	47.1	-26.9	74	54.05	40.2	9.77	57.44	100	0	P	H
		17100	59.1	-14.9	74	61.14	41.62	11.99	56.3	204	24	P	H
		17100	43.63	-10.37	54	45.67	41.62	11.99	56.3	204	24	A	H
													H
		7600	51.68	-22.32	74	64.71	37.4	7.9	59.16	100	326	P	V
		7600	46.7	-7.3	54	59.73	37.4	7.9	59.16	100	326	A	V
		11400	47.54	-26.46	74	54.49	40.2	9.77	57.44	100	0	P	V
		17100	62.35	-11.65	74	64.39	41.62	11.99	56.3	110	23	P	V
	17100	45.57	-8.43	54	47.61	41.62	11.99	56.3	110	23	A	V	
Remark	1. No other spurious found. 2. All results are PASS against Peak and Average limit line.												



Emission below 1GHz

WIFI 802.11a (LF @ 3m)

WIFI	Note	Frequency	Level	Over	Limit	Read	Antenna	Cable	Preamp	Ant	Table	Peak	Pol.	
Ant.				Limit	Line	Level	Factor	Loss	Factor	Pos	Pos	Avg.		
1		(MHz)	(dBμV/m)	(dB)	(dBμV/m)	(dBμV)	(dB/m)	(dB)	(dB)	(cm)	(deg)	(P/A)	(H/V)	
802.11a LF		38.91	24.11	-15.89	40	33.88	20.06	0.48	30.3			P	H	
		101.28	27.29	-16.21	43.5	40.59	16.25	0.8	30.4			P	H	
		150.69	24.12	-19.38	43.5	35.99	17.32	1.02	30.33			P	H	
		566.7	26.74	-19.26	46	28.35	26.06	1.92	29.7			P	H	
		729.1	31.84	-14.16	46	31.39	27.65	2.18	29.48	100	0	P	H	
		982.5	31.87	-22.13	54	27.1	31.01	2.53	29			P	H	
													H	
													H	
													H	
													H	
													H	
													H	
			38.1	34.6	-5.4	40	43.88	20.55	0.48	30.29	100	0	P	V
			73.74	26.29	-13.71	40	43.41	12.58	0.68	30.43			P	V
			99.93	26.98	-16.52	43.5	40.36	16.17	0.8	30.4			P	V
			514.9	24.28	-21.72	46	27.94	24.2	1.83	29.77			P	V
			729.1	30.98	-15.02	46	30.53	27.65	2.18	29.48			P	V
			897.1	36.51	-9.49	46	33.85	29.24	2.42	29.17			P	V
												V		
												V		
												V		
												V		
												V		
												V		
Remark	1. No other spurious found. 2. All results are PASS against limit line.													



Note symbol

*	Fundamental Frequency which can be ignored. However, the level of any unwanted emissions shall not exceed the level of the fundamental frequency.
!	Test result is over limit line.
P/A	Peak or Average
H/V	Horizontal or Vertical



A calculation example for radiated spurious emission is shown as below:

WIFI	Note	Frequency	Level	Over	Limit	Read	Antenna	Cable	Preamp	Ant	Table	Peak	Pol.
Ant.				Limit	Line	Level	Factor	Loss	Factor	Pos	Pos	Avg.	
1		(MHz)	(dBμV/m)	(dB)	(dBμV/m)	(dBμV)	(dB/m)	(dB)	(dB)	(cm)	(deg)	(P/A)	(H/V)
802.11b		2390	55.45	-18.55	74	54.51	32.22	4.58	35.86	103	308	P	H
CH 01													
2412MHz		2390	43.54	-10.46	54	42.6	32.22	4.58	35.86	103	308	A	H

- Level(dBμV/m) =
Antenna Factor(dB/m) + Cable Loss(dB) + Read Level(dBμV) - Preamp Factor(dB)
- Over Limit(dB) = Level(dBμV/m) – Limit Line(dBμV/m)

For Peak Limit @ 2390MHz:

- Level(dBμV/m)
= Antenna Factor(dB/m) + Cable Loss(dB) + Read Level(dBμV) - Preamp Factor(dB)
= 32.22(dB/m) + 4.58(dB) + 54.51(dBμV) – 35.86 (dB)
= 55.45 (dBμV/m)
- Over Limit(dB)
= Level(dBμV/m) – Limit Line(dBμV/m)
= 55.45(dBμV/m) – 74(dBμV/m)
= -18.55(dB)

For Average Limit @ 2390MHz:

- Level(dBμV/m)
= Antenna Factor(dB/m) + Cable Loss(dB) + Read Level(dBμV) - Preamp Factor(dB)
= 32.22(dB/m) + 4.58(dB) + 42.6(dBμV) – 35.86 (dB)
= 43.54 (dBμV/m)
- Over Limit(dB)
= Level(dBμV/m) – Limit Line(dBμV/m)
= 43.54(dBμV/m) – 54(dBμV/m)
= -10.46(dB)

Both peak and average measured complies with the limit line, so test result is “PASS”.



Appendix C. Radiated Spurious Emission

Test Engineer :	Nick Yu / Ray Chen	Temperature :	23~25°C
		Relative Humidity :	61~63%

Note symbol

-L	Low channel location
-R	High channel location



Band 1 - 5150~5250MHz
WIFI 802.11a (Band Edge @ 3m)

WIFI	Band 1 5150~5250MHz Band Edge @ 3m	
ANT	802.11a CH48 5240MHz - L	
1	Horizontal	Fundamental
Peak		
Avg.		Left blank

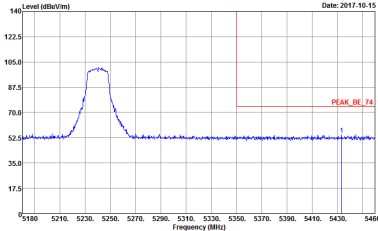
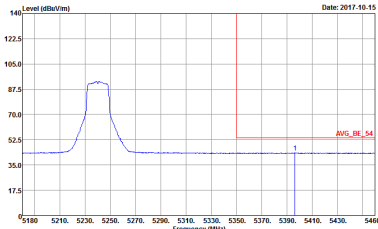

WIFI	Band 1 5150~5250MHz Band Edge @ 3m	
ANT	802.11a CH48 5240MHz - R	
1	Horizontal	Fundamental
<p>Peak</p>	 <p>Site Condition : 03CH12-HY : PEAK_BE_74 3m HORN_9120D_1328 HORIZONTAL</p>	<p>Left blank</p>
<p>Avg.</p>	 <p>Site Condition : 03CH12-HY : AVG_BE_54 3m HORN_9120D_1328 HORIZONTAL</p>	<p>Left blank</p>



WIFI	Band 1 5150~5250MHz Band Edge @ 3m	
ANT	802.11a CH48 5240MHz - L	
1	Vertical	Fundamental
Peak	<p>Site Condition : 03CH12-HY : PEAK_BE_74 3m HORN_9120D_1328 VERTICAL</p>	<p>Site Condition : 03CH12-HY : PEAK_74 3m HORN_9120D_1328 VERTICAL</p>
Avg.	<p>Site Condition : 03CH12-HY : AVG_BE_54 3m HORN_9120D_1328 VERTICAL</p>	Left blank

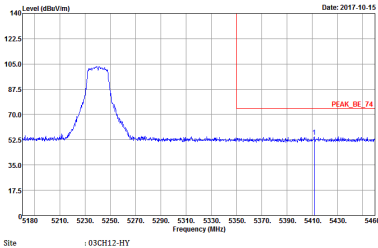
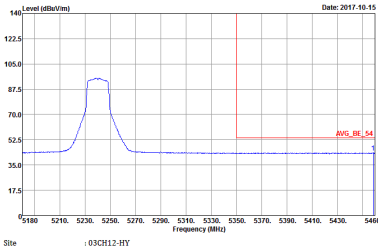

WIFI	Band 1 5150~5250MHz Band Edge @ 3m	
ANT	802.11a CH48 5240MHz - R	
1	Vertical	Fundamental
Peak	 <p>Site Condition : 03CH12-HY : PEAK_BE_74 3m HORN_9120D_1328 VERTICAL</p>	Left blank
Avg.	 <p>Site Condition : 03CH12-HY : AVG_BE_54 3m HORN_9120D_1328 VERTICAL</p>	Left blank



Band 1 - 5150~5250MHz
WIFI 802.11a (Harmonic @ 3m)

WIFI	Band 1 5150~5250MHz Harmonic @ 3m	
ANT	802.11a CH48 5240MHz	
1	Horizontal	Vertical
Peak Avg.	<p>Site Condition : 03C112-HY : PEAK_74 3m HORN_9120D_1328 HORIZONTAL</p>	<p>Site Condition : 03C112-HY : PEAK_74 3m HORN_9120D_1328 VERTICAL</p>



Band 2 - 5250~5350MHz
WIFI 802.11a (Band Edge @ 3m)

Table with 2 columns (WIFI, ANT) and 2 rows (Peak, Avg.). It contains spectral plots for Horizontal and Fundamental views. The Peak row shows a signal peak at 5320MHz in the Horizontal view and a sharp peak at 5320MHz in the Fundamental view. The Avg. row shows the average signal level in the Horizontal view, which is blank in the Fundamental view.

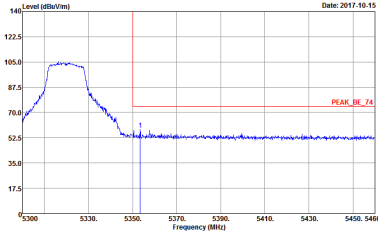
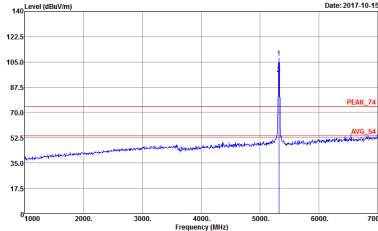
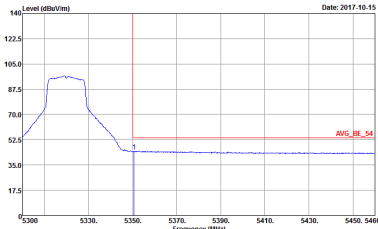

WIFI	Band 2 5250~5350MHz Band Edge @ 3m	
ANT	802.11a CH64 5320MHz	
1	Vertical	Fundamental
Peak	 <p>Site Condition : 03CH12-HY : PEAK_BE_74 3m HORN_9120D_1328 VERTICAL</p>	 <p>Site Condition : 03CH12-HY : PEAK_74 3m HORN_9120D_1328 VERTICAL</p>
Avg.	 <p>Site Condition : 03CH12-HY : AVG_BE_54 3m HORN_9120D_1328 VERTICAL</p>	Left blank



Band 2 - 5250~5350MHz
WIFI 802.11a (Harmonic @ 3m)

WIFI	Band 2 5250~5350MHz Harmonic @ 3m	
ANT	802.11a CH64 5320MHz	
1	Horizontal	Vertical
Peak Avg.	<p>Site : 03C112-HY Condition : PEAK_74 3m HORN_9120D_1328 HORIZONTAL</p>	<p>Site : 03C112-HY Condition : PEAK_74 3m HORN_9120D_1328 VERTICAL</p>



Band 3 - 5470~5725MHz
WIFI 802.11a (Band Edge @ 3m)

Table with 2 columns (WIFI, ANT) and 2 rows (Peak, Avg.). It contains spectral plots for 'Horizontal' and 'Fundamental' views. The 'Peak' row shows a peak at 5725 MHz in the horizontal view and a peak at 5725 MHz in the fundamental view. The 'Avg.' row shows an average level at 5725 MHz in the horizontal view and is labeled 'Left blank' in the fundamental view.



WIFI	Band 3 5470~5725MHz Band Edge @ 3m	
ANT	802.11a CH140 5700MHz	
1	Vertical	Fundamental
Peak	<p>Site Condition : 03CH12-HY : PEAK_BE_74 3m HORN_9120D_1328 VERTICAL</p>	<p>Site Condition : 03CH12-HY : PEAK_74 3m HORN_9120D_1328 VERTICAL</p>
Avg.	<p>Site Condition : 03CH12-HY : AVG_BE_54 3m HORN_9120D_1328 VERTICAL</p>	Left blank



Band 3 - 5470~5725MHz
WIFI 802.11a (Harmonic @ 3m)

WIFI	Band 3 5470~5725MHz Harmonic @ 3m	
ANT	802.11a CH140 5700MHz	
1	Horizontal	Vertical
Peak Avg.	<p>Site Condition : 03C112-HY : PEAK_74 3m HORN_9120D_1328 HORIZONTAL</p>	<p>Site Condition : 03C112-HY : PEAK_74 3m HORN_9120D_1328 VERTICAL</p>

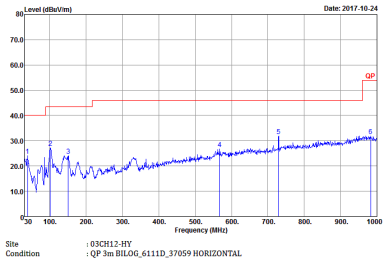
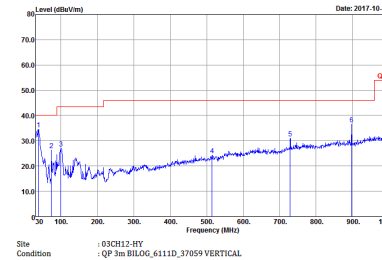

Emission below 1GHz
5GHz WIFI 802.11a (LF)

WIFI	5GHz WIFI	
ANT	802.11a LF	
1	Horizontal	Vertical
QP / Peak	 <p>Site: 03CH12-RY Condition: QP 3m BILOG_6111D_37059 HORIZONTAL</p>	 <p>Site: 03CH12-RY Condition: QP 3m BILOG_6111D_37059 VERTICAL</p>



Appendix D Duty Cycle Plots

Band	Duty Cycle(%)	T(us)	1/T(kHz)	VBW Setting	Duty Factor(dB)
802.11a	94.78	2032	0.49	1kHz	0.23
5GHz 802.11n HT20	94.40	1888	0.53	1kHz	0.25
5GHz 802.11n HT40	91.34	928	1.08	3kHz	0.39
5GHz 802.11ac VHT20	95.00	1900	0.53	1kHz	0.22
5GHz 802.11ac VHT40	90.39	940	1.06	3kHz	0.44
5GHz 802.11ac VHT80	89.58	860	1.16	3kHz	0.48



802.11a

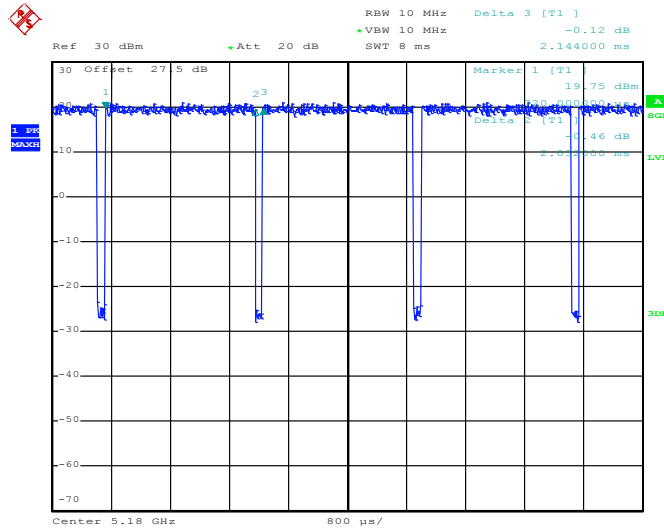

Date: 14.SEP.2017 10:39:21

802.11n HT20

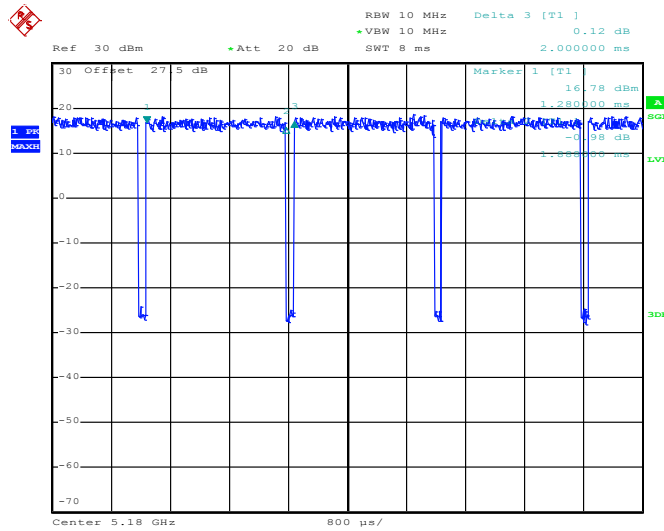

Date: 14.SEP.2017 10:57:20



802.11n HT40

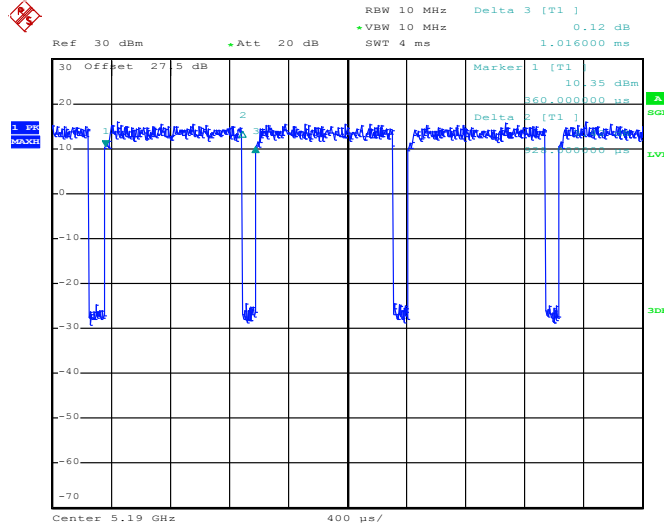

Date: 14.SEP.2017 11:04:43

802.11ac VHT20

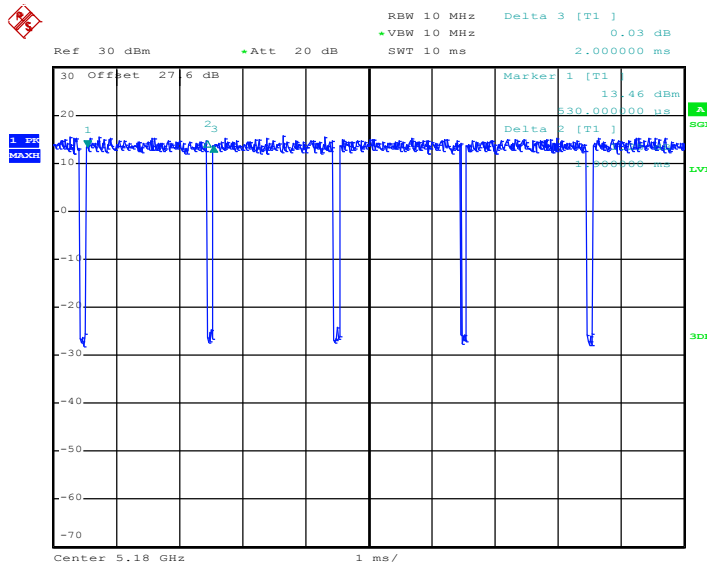

Date: 28.SEP.2017 01:27:34



802.11ac VHT40

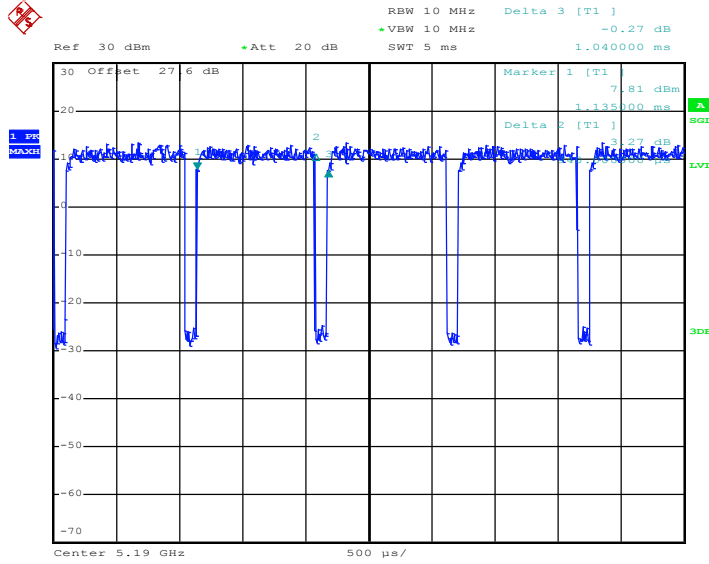

Date: 28.SEP.2017 01:28:16

802.11ac VHT80

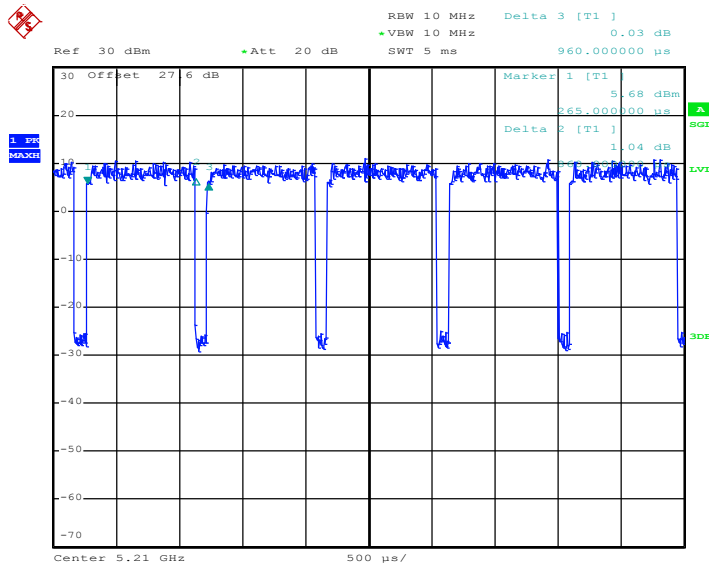

Date: 28.SEP.2017 01:24:22



Appendix E. Original Report

Please refer to Sporton report number FR760710-01E