



CERTIFICATION TEST REPORT

Report Number. : 11626381H-E4V2

Applicant : SONY MOBILE COMMUNICATIONS, INC.
4-12-3 HIGASHI-SHINAGAWA,
SHINAGAWA -KU,TOKYO, 140-0002, JAPAN

FCC ID : PY7-54254H

EUT Description : GSM/WCDMA/LTE Phone with BT, DTS/UNII a/b/g/n/ac, GPS & NFC

Test Standard(s) : FCC 47 CFR PART 15 SUBPART C
INDUSTRY CANADA RSS - 247 ISSUE 1
INDUSTRY CANADA RSS-GEN ISSUE 4

Date Of Issue:

April 07, 2017

Prepared by:

UL Verification Services Inc.
47173 Benicia Street
Fremont, CA 94538, U.S.A.
TEL: (510) 771-1000
FAX: (510) 661-0888



NVLAP LAB CODE 200065-0

Revision History

<u>Rev.</u>	<u>Issue Date</u>	<u>Revisions</u>	<u>Revised By</u>
V1	3/24/17	Initial Issue	C. Vergonio
V2	4/7/17	Updated Section 8 FCC rule part. Added note in Section 9.1. Updated Section 9.2.3, 9.3.3 & 9.4.3 FCC rule part. Updated Section 9.2.4, 9.3.4, & 9.4.4 FCC rule part. Lab re-tested 99% BW and updated Section 9.3.2 and Section 9.4.2 table and plot.	C. Vergonio

TABLE OF CONTENTS

1. ATTESTATION OF TEST RESULTS	5
2. TEST METHODOLOGY	6
3. FACILITIES AND ACCREDITATION	6
4. CALIBRATION AND UNCERTAINTY	7
4.1. <i>MEASURING INSTRUMENT CALIBRATION</i>	7
4.2. <i>SAMPLE CALCULATION</i>	7
4.3. <i>MEASUREMENT UNCERTAINTY</i>	7
5. EQUIPMENT UNDER TEST	8
5.1. <i>DESCRIPTION OF EUT</i>	8
5.2. <i>MAXIMUM OUTPUT POWER</i>	8
5.3. <i>DESCRIPTION OF AVAILABLE ANTENNAS</i>	8
5.4. <i>SOFTWARE AND FIRMWARE</i>	8
5.5. <i>WORST-CASE CONFIGURATION AND MODE</i>	9
5.6. <i>DESCRIPTION OF TEST SETUP</i>	10
6. TEST AND MEASUREMENT EQUIPMENT	13
7. MEASUREMENT METHODS	14
8. SUMMARY TABLE	15
9. ANTENNA PORT TEST RESULTS	16
9.1. <i>ON TIME AND DUTY CYCLE</i>	16
9.2. <i>11b 2TX MIMO MODE IN THE 2.4GHz BAND</i>	19
9.2.1. 6 dB BANDWIDTH	19
9.2.2. 99% BANDWIDTH	25
9.2.3. OUTPUT POWER	31
9.2.4. POWER SPECTRAL DENSITY	33
9.2.5. CONDUCTED BANDEDGE AND SPURIOUS EMISSIONS	39
9.3. <i>11g 2TX CDD MIMO MODE IN THE 2.4GHz BAND</i>	49
9.3.1. 6 dB BANDWIDTH	49
9.3.2. 99% BANDWIDTH	58
9.3.3. OUTPUT POWER	67
9.3.4. POWER SPECTRAL DENSITY	69
9.3.5. CONDUCTED BANDEDGE AND SPURIOUS EMISSIONS	78
9.4. <i>11n HT20 2TX CDD MIMO MODE IN THE 2.4GHz BAND</i>	94
9.4.1. 6 dB BANDWIDTH	94

9.4.2.	99% BANDWIDTH	103
9.4.3.	OUTPUT POWER	112
9.4.4.	POWER SPECTRAL DENSITY	114
9.4.5.	CONDUCTED BANDEDGE AND SPURIOUS EMISSIONS	123
10.	RADIATED TEST RESULTS.....	139
10.1.	LIMITS AND PROCEDURE.....	139
10.2.	TRANSMITTER ABOVE 1 GHz.....	140
10.2.1	11b Chain 0 and Chain 1 MIMO MODE IN THE 2.4GHz BAND	140
10.2.2	11g Chain 0 AND Chain 1 MIMO MODE IN THE 2.4GHz BAND.....	154
10.2.3	11n-HT20 Chain 0 AND Chain 1 MIMO MODE IN THE 2.4GHz BAND.....	174
10.3	WORST-CASE BELOW 30 MHz.....	194
10.4	WORST-CASE BELOW 1 GHz	195
10.5	WORST-CASE 18 to 26 GHz	197
11	AC POWER LINE CONDUCTED EMISSIONS	199
11.2	EUT POWERED BY AC/DC ADAPTER VIA USB CABLE.....	200
12	SETUP PHOTOS	202

1. ATTESTATION OF TEST RESULTS

COMPANY NAME: SONY MOBILE COMMUNICATIONS, INC.
4-12-3 HIGASHI-SHINAGAWA,
SHINAGAWA -KU, TOKYO, 140-0002, JAPAN

EUT DESCRIPTION: GSM/WCDMA/LTE Phone with BT, DTS/UNII a/b/g/n/ac, GPS & NFC

SERIAL NUMBER: RADIATED: CB512DQZV2, CB512DQZU5
CONDUCTED: CB512DHRTV, CB512DHRVC

DATE TESTED: MARCH 12, 2017 – APRIL 7, 2017

APPLICABLE STANDARDS	
STANDARD	TEST RESULTS
CFR 47 Part 15 Subpart C	Pass
INDUSTRY CANADA RSS-247 Issue 1	Pass
INDUSTRY CANADA RSS-GEN Issue 4	Pass

UL Verification Services Inc. tested the above equipment in accordance with the requirements set forth in the above standards. All indications of Pass/Fail in this report are opinions expressed by UL Verification Services Inc. based on interpretations and/or observations of test results. Measurement Uncertainties were not taken into account and are published for informational purposes only. The test results show that the equipment tested is capable of demonstrating compliance with the requirements as documented in this report.

Note: The results documented in this report apply only to the tested sample, under the conditions and modes of operation as described herein. This document may not be altered or revised in any way unless done so by UL Verification Services Inc. and all revisions are duly noted in the revisions section. Any alteration of this document not carried out by UL Verification Services Inc. will constitute fraud and shall nullify the document. This report must not be used by the client to claim product certification, approval, or endorsement by NVLAP, NIST, any agency of the Federal Government, or any agency of any government.

Approved & Released For
UL Verification Services Inc. By:

Prepared By:



CHARLES VERGONIO
WISE PROJECT LEAD
UL VERIFICATION SERVICES INC.

JASON QIAN
WISE LABORATORY ENGINEER
UL VERIFICATION SERVICES INC.

2. TEST METHODOLOGY

The tests documented in this report were performed in accordance with FCC CFR 47 Part 2, FCC CFR 47 Part 15, KDB 558074 D01 v03r05, KDB 662911 D01 Multiple Transmitter Output v02r01, ANSI C63.10-2013, RSS-GEN Issue 4, and RSS-247 Issue 1.

3. FACILITIES AND ACCREDITATION

The test sites and measurement facilities used to collect data are located at 47173 and 47266 Benicia Street, Fremont, California, USA. Line conducted emissions are measured only at the 47173 address. The following table identifies which facilities were utilized for radiated emission measurements documented in this report. Specific facilities are also identified in the test results sections.

47173 Benicia Street	47266 Benicia Street
<input checked="" type="checkbox"/> Chamber A (IC:2324B-1)	<input type="checkbox"/> Chamber D (IC:2324B-4)
<input checked="" type="checkbox"/> Chamber B (IC:2324B-2)	<input type="checkbox"/> Chamber E (IC:2324B-5)
<input checked="" type="checkbox"/> Chamber C (IC:2324B-3)	<input type="checkbox"/> Chamber F (IC:2324B-6)
	<input type="checkbox"/> Chamber G (IC:2324B-7)
	<input type="checkbox"/> Chamber H (IC:2324B-8)

The above test sites and facilities are covered under FCC Test Firm Registration # 208313.

UL Verification Services Inc. is accredited by NVLAP, Laboratory Code 200065-0. The full scope of accreditation can be viewed at <http://ts.nist.gov/standards/scopes/2000650.htm>.

4. CALIBRATION AND UNCERTAINTY

4.1. MEASURING INSTRUMENT CALIBRATION

The measuring equipment utilized to perform the tests documented in this report has been calibrated in accordance with the manufacturer's recommendations, and is traceable to recognized national standards.

4.2. SAMPLE CALCULATION

Where relevant, the following sample calculation is provided:

$$\begin{aligned} \text{Field Strength (dBuV/m)} &= \text{Measured Voltage (dBuV)} + \text{Antenna Factor (dB/m)} + \\ &\text{Cable Loss (dB)} - \text{Preamp Gain (dB)} \\ 36.5 \text{ dBuV} + 18.7 \text{ dB/m} + 0.6 \text{ dB} - 26.9 \text{ dB} &= 28.9 \text{ dBuV/m} \end{aligned}$$

4.3. MEASUREMENT UNCERTAINTY

Where relevant, the following measurement uncertainty levels have been estimated for tests performed on the apparatus:

Parameter	Uncertainty
Worst Case Conducted Disturbance, 9KHz to 0.15 MHz	3.84 dB
Worst Case Conducted Disturbance, 0.15 to 30 MHz	3.65 dB
Worst Case Radiated Disturbance, 9KHz to 30 MHz	3.15 dB
Worst Case Radiated Disturbance, 30 to 1000 MHz	5.36 dB
Worst Case Radiated Disturbance, 1000 to 18000 MHz	4.32 dB
Worst Case Radiated Disturbance, 18000 to 26000 MHz	4.45 dB
Worst Case Radiated Disturbance, 26000 to 40000 MHz	5.24 dB

Uncertainty figures are valid to a confidence level of 95%.

5. EQUIPMENT UNDER TEST

5.1. DESCRIPTION OF EUT

The EUT is a GSM/WCDMA/LTE Phone with BT, DTS/UNII a/b/g/n/ac, GPS & NFC.

5.2. MAXIMUM OUTPUT POWER

The transmitter has a maximum conducted output power as follows:

Frequency Range (MHz)	Mode	Output Power (dBm)	Output Power (mW)
2412 - 2472	802.11b 2TX	21.72	148.59
2412 - 2472	802.11g 2TX	21.54	142.56
2412 - 2472	802.11n HT20 2TX CDD	21.55	142.89

5.3. DESCRIPTION OF AVAILABLE ANTENNAS

Frequency Band (GHz)	Antenna Gain (dBi)	
	Chain 0	Chain 1
2.4	-5.20	-9.80

5.4. SOFTWARE AND FIRMWARE

The firmware installed in the EUT during testing was SONY, s_atp_1_00067_A_9_4.
The test utility software used during testing was Tera Term Ver 4.79.

5.5. WORST-CASE CONFIGURATION AND MODE

Radiated bandedge, harmonics, and spurious emissions from 1 GHz to 18GHz were performed. The EUT was set to transmit at the Low/Middle/High channels.

Radiated emission below 1GHz, above 18GHz, and power line conducted emission were performed with the EUT was set to transmit at the channel with highest output power as worst-case scenario.

The fundamental of the EUT was investigated in three orthogonal orientations X/Y/Z, it was determined that Z orientation was worst-case orientation. Therefore, all final radiated testing was performed with the EUT in Z orientation.

Worst-case data rates as provided by the client were:

802.11b mode: 1 Mbps
802.11g mode: 6 Mbps
802.11n HT20mode: MCS0

5.6. DESCRIPTION OF TEST SETUP

SUPPORT EQUIPMENT

Support Equipment List				
Description	Manufacturer	Model	Serial Number	FCC ID
Laptop	Lenovo	20B7S0A200	PC015REW	NA
AC Adapter	SONY	1300-7137.1	4016W40310044	NA
Headphones	SONY	N/A	N/A	N/A

I/O CABLES (CONDUCTED TEST)

I/O Cable List						
Cable No	Port	# of identical ports	Connector Type	Cable Type	Cable Length (m)	Remarks
1	Antenna	1	RF	Shielded	0.2	To Spectrum Analyzer
2	USB	1	USB	Shielded	1	N/A
3	DC	1	DC	Shielded	0.3	N/A

I/O CABLES (RADIATED AND CONDUCTED EMISSIONS)

I/O Cable List						
Cable No	Port	# of identical ports	Connector Type	Cable Type	Cable Length (m)	Remarks
1	USB	1	USB	Shielded	3	N/A
2	Audio	1	3.5mm	Shielded	1	N/A

TEST SETUP

CONDUCTED TEST SETUP DIAGRAM

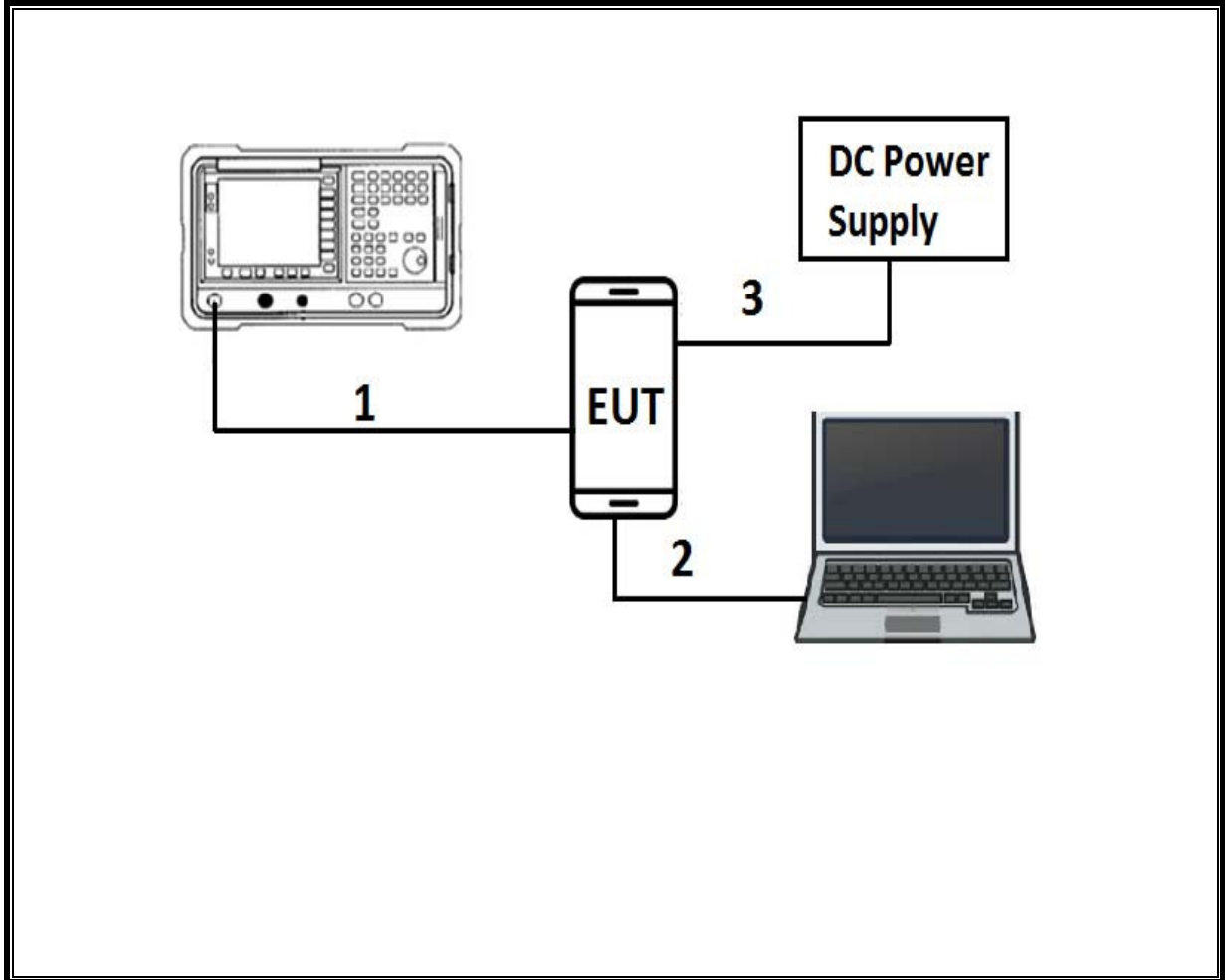

TEST SETUP

RADIATED AND AC LINE CONDUCTED EMISSIONS SETUP DIAGRAM

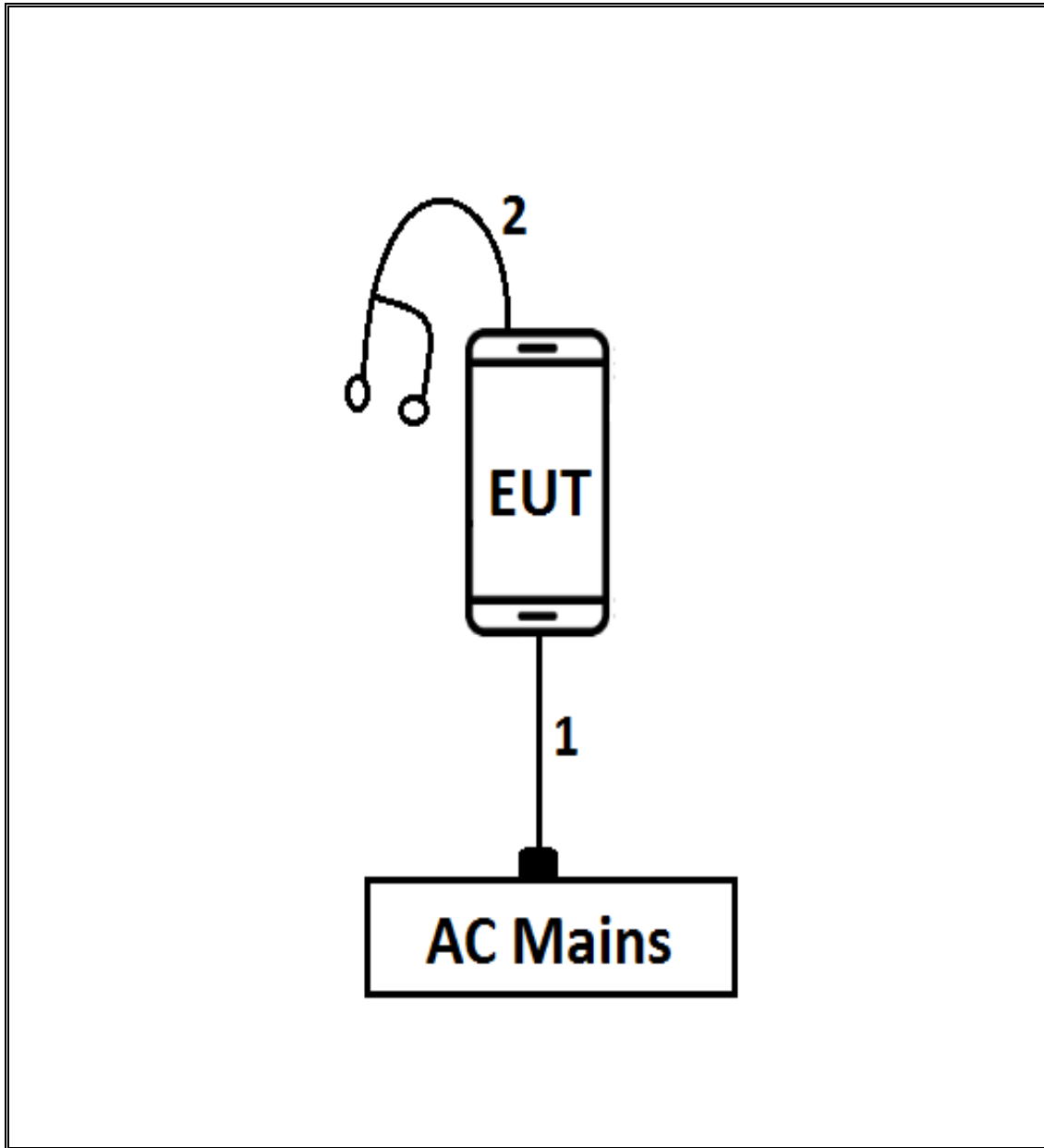

6. TEST AND MEASUREMENT EQUIPMENT

The following test and measurement equipment was utilized for the tests documented in this report:

TEST EQUIPMENT LIST				
Description	Manufacturer	Model	Asset	Cal Due
Antenna, Broadband Hybrid, 30MHz to 2000MHz w/4dB Pad	Sunol Sciences Corp.	JB3	T477	06/22/2017
Antenna, Active Loop 9kHz-30MHz	ETS-Lindgren	6502	T1683	02/17/2018
Antenna, Horn 1-18GHz	ETS-Lindgren	3117	T712	01/30/2018
Antenna, Horn 1-18GHz	ETS-Lindgren	3117	T346	02/22/2018
Antenna, Horn 18-26.5GHz	ARA	MWH-1826/B	T449	05/26/2017
Antenna, Horn 26.5 - 40GHz	ARA	MWH-1826/B	T449	05/26/2017
Power Meter, P-series single channel	Agilent (Keysight) Technologies	N1911A	T1264	07/08/2017
Power Sensor, P – series, 50MHz to 18GHz, Wideband	Agilent (Keysight) Technologies	N1921A	T413	06/20/2017
Amplifier, 1-26.5GHz	MITEQ	AFS42-00101800-25-S-42	T1165	08/01/2017
Amplifier, 1-26.5GHz	Agilent (Keysight) Technologies	8449B	T404	07/05/2017
Amplifier, 10kHz-1GHz	Agilent (Keysight) Technologies	8447D	T15	08/26/2017
Amplifier, 1-8 GHz	MITEQ	AMF-4D-01000800-30-29P	T1170	04/28/2017
Spectrum Analyzer, PSA, 3Hz to 26.5GHz	Agilent (Keysight) Technologies	E4440A	T199	07/22/2017
Spectrum Analyzer, PSA, 3Hz to 26.5GHz	Agilent (Keysight) Technologies	E4440A	T908	04/13/2017
Spectrum Analyzer, PXA, 3Hz to 44GHz	Agilent (Keysight) Technologies	N9030A	T907	01/23/2018
Spectrum Analyzer, PSA, 3Hz to 26.5GHz	Agilent (Keysight) Technologies	E9030A	T905	01/11/2018
LISN	FISCHER	FCC-LISN-50/250-25-2-01	T1310	06/08/2017

Test Software List			
Description	Manufacturer	Model	Version
Radiated Software	UL	UL EMC	Ver 9.5, Apr 26, 2016
Conducted Software	UL	UL EMC	Ver 9.5, May 26, 2015
Antenna Port Software	UL	UL RF	Ver 5.1.1, July 15, 2016

The following test and measurement equipment was utilized for the tests documented in this report:

NOTE: *testing is completed before equipment calibration expiration date.

7. MEASUREMENT METHODS

On Time and Duty Cycle: KDB 558074 D01 v03r05, Section 6.

6 dB BW: KDB 558074 D01 v03r05, Section 8.1.

99% BW: ANSI C63.10-2013, Section 6.9.3.

Output Power: KDB 558074 D01 v03r05, Section 9.2.3.2.

Power Spectral Density: KDB 558074 D01 v03r05, Section 10.3.

Out-of-band emissions in non-restricted bands: KDB 558074 D01 v03r05, Section 11.0.

Out-of-band emissions in restricted bands: KDB 558074 D01 v03r05, Section 12.1.

Band-edge: KDB 558074 D01 v03r05, Section 12.1.

AC Power Line Conducted Emissions: ANSI C63.10-2013, Section 6.2.

8. SUMMARY TABLE

FCC Part Section	RSS Section(s)	Test Description	Test Limit	Test Condition	Test Result
15.247 (a)(2)	RSS-247 5.2.1	Occupied Band width (6dB)	>500KHz	Conducted	Pass
2.1051, 15.247 (d)	RSS-247 5.5	Band Edge / Conducted Spurious Emission	-30dBc		Pass
15.247 (b) (3)	RSS-247 5.4.4	TX conducted output power	<30dBm		Pass
15.247 (e)	RSS-247 5.2.2	PSD	<8dBm		Pass
15.207 (a)	RSS-GEN 8.8	AC Power Line conducted emissions	Section 10	Radiated	Pass
15.205, 15.209, 15.247(d)	RSS-GEN 8.9/7	Radiated Spurious Emission	< 54dBuV/m		Pass

9. ANTENNA PORT TEST RESULTS

9.1. ON TIME AND DUTY CYCLE

LIMITS

None; for reporting purposes only.

PROCEDURE

KDB 558074 Zero-Span Spectrum Analyzer Method.

ON TIME AND DUTY CYCLE RESULTS

Mode	ON Time (msec)	Period (msec)	Duty Cycle x (linear)	Duty Cycle (%)	Duty Cycle Correction Factor (dB)	1/T Minimum VBW (kHz)
802.11b	12.210	12.330	0.990	99.03%	0.00	0.010
802.11g	2.025	2.155	0.940	93.97%	0.27	0.494
802.11n HT20 CDD	4.968	5.096	0.975	97.49%	0.11	0.201

Note: Chain 1 was tested to represent the worst chain.

DUTY CYCLE PLOTS

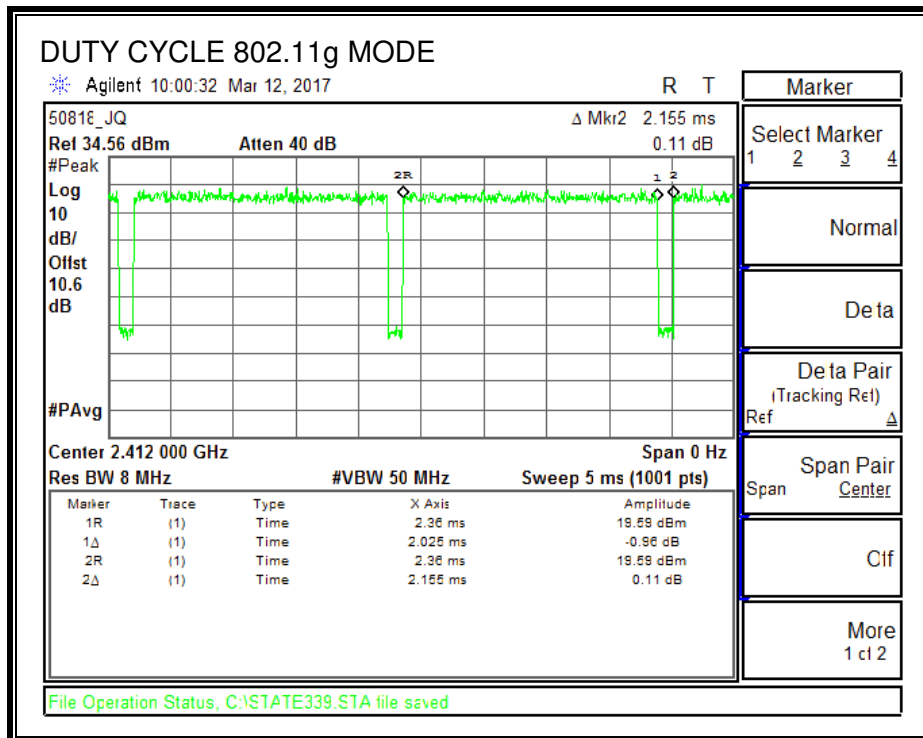
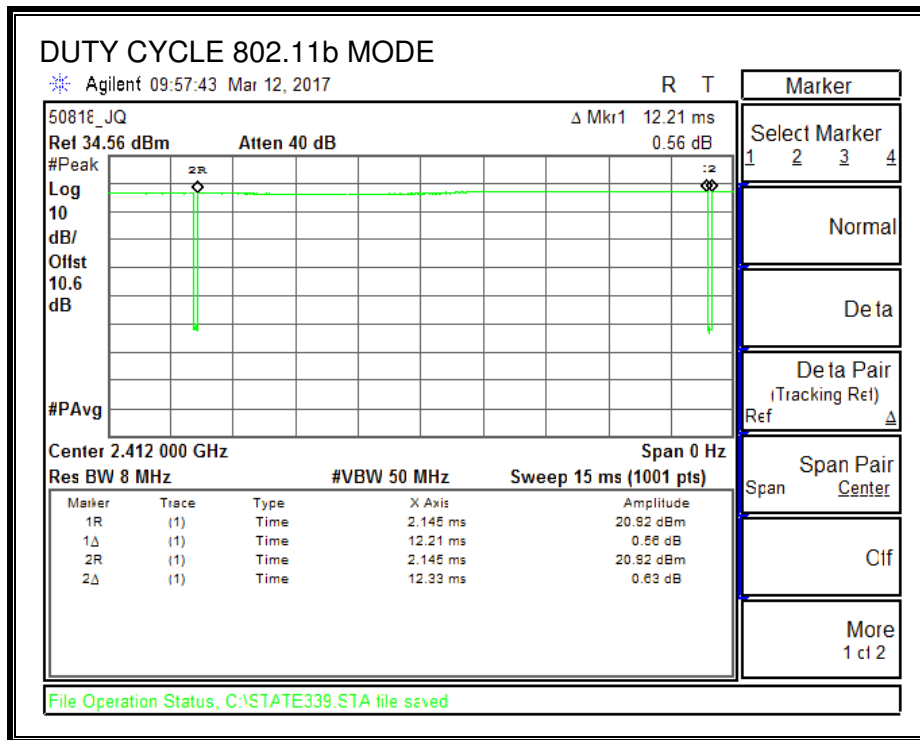

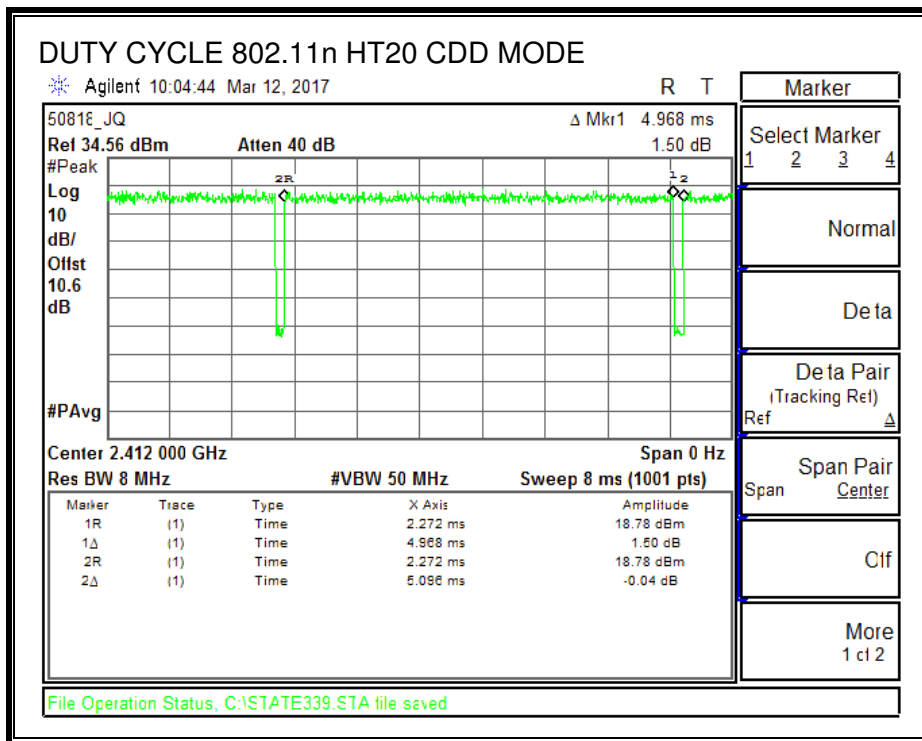

9.2. 11b 2TX MIMO MODE IN THE 2.4GHz BAND

9.2.1. 6 dB BANDWIDTH

LIMITS

FCC §15.247 (a) (2)
IC RSS-247 (5.2) (1)

The minimum 6 dB bandwidth shall be at least 500 kHz.

RESULTS

Channel	Frequency (MHz)	6 dB BW Chain 0 (MHz)	6 dB BW Chain 1 (MHz)	Minimum Limit (MHz)
CH1	2412	7.060	7.070	0.5
CH6	2437	7.070	8.060	0.5
CH11	2462	7.525	7.550	0.5
CH12	2467	6.495	6.135	0.5
CH13	2472	7.565	7.560	0.5

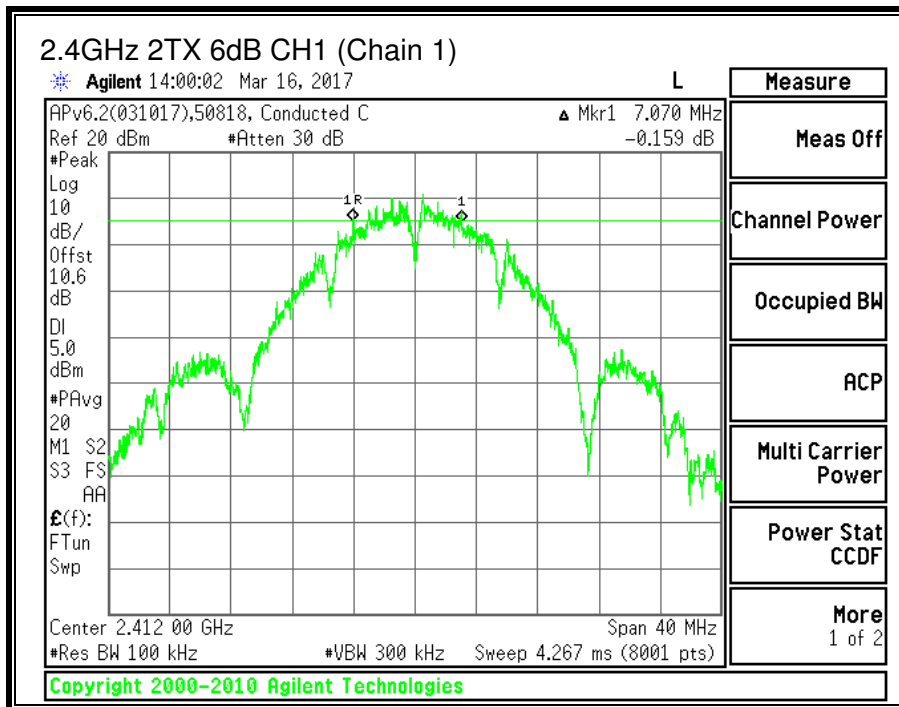
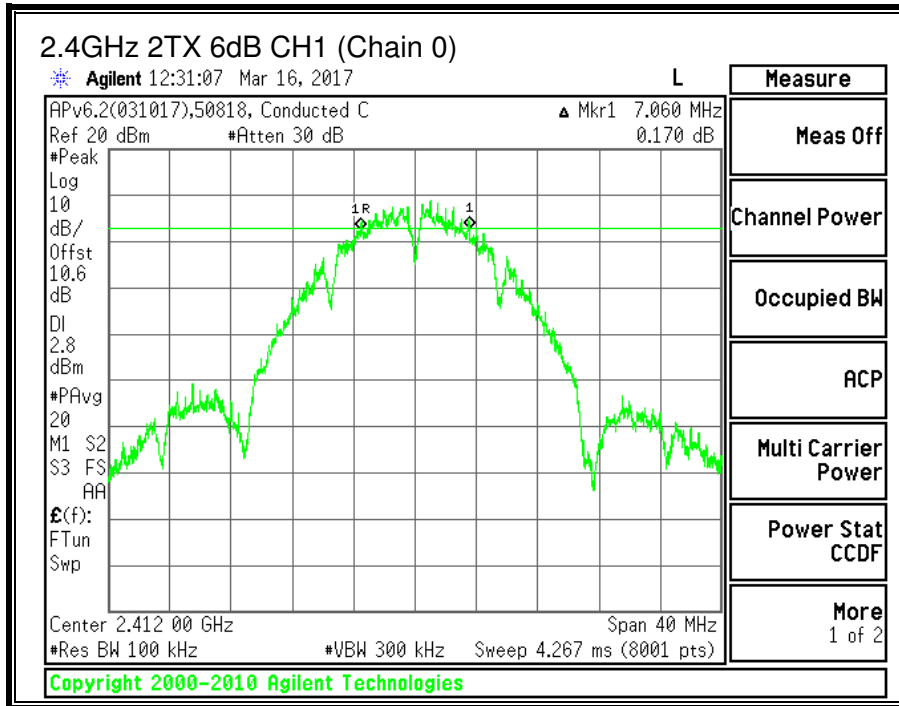

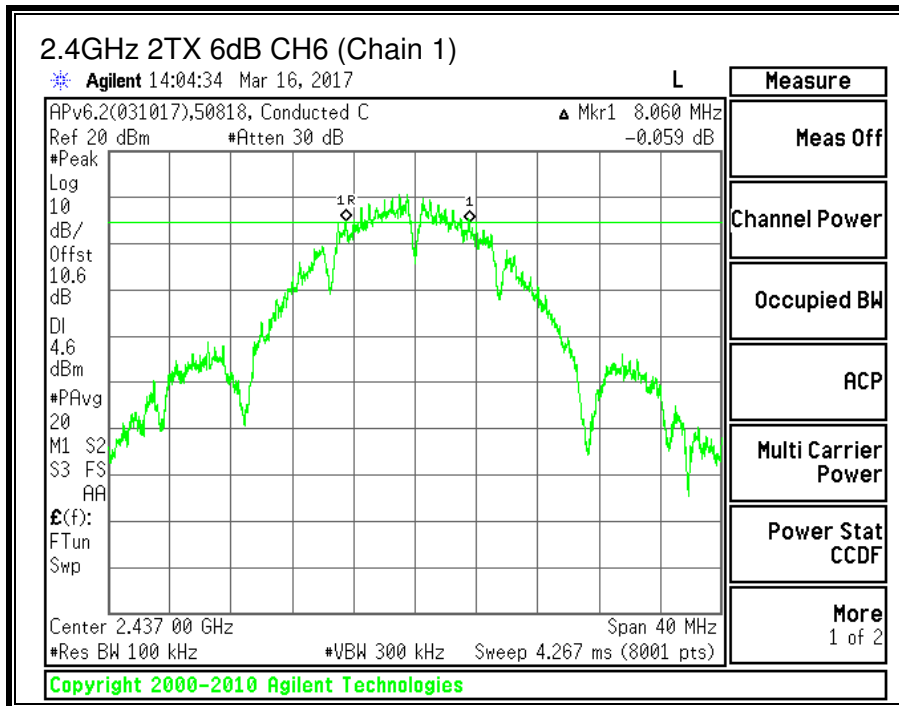
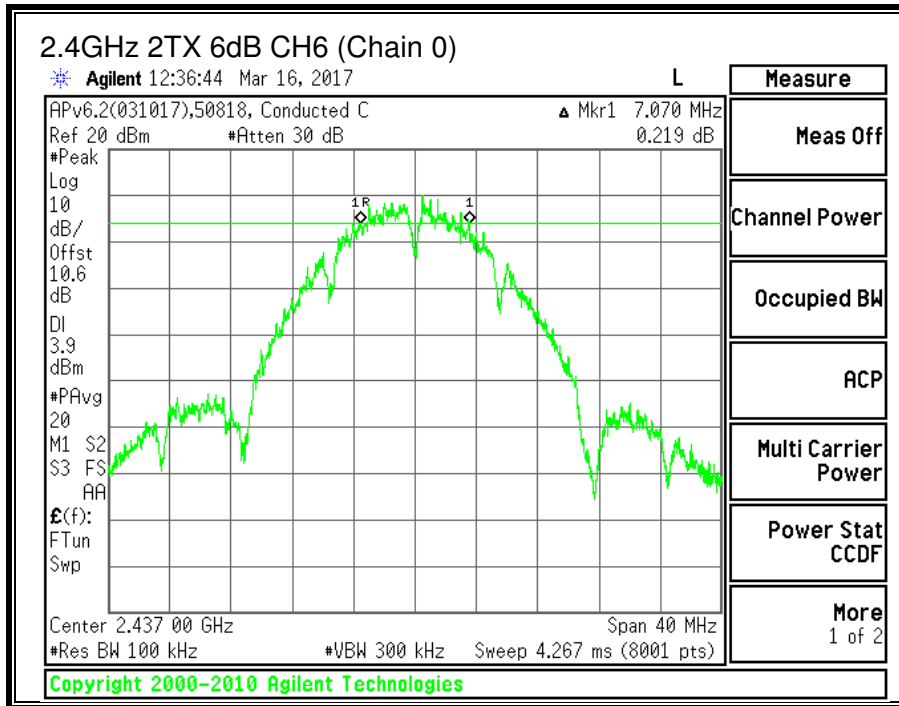

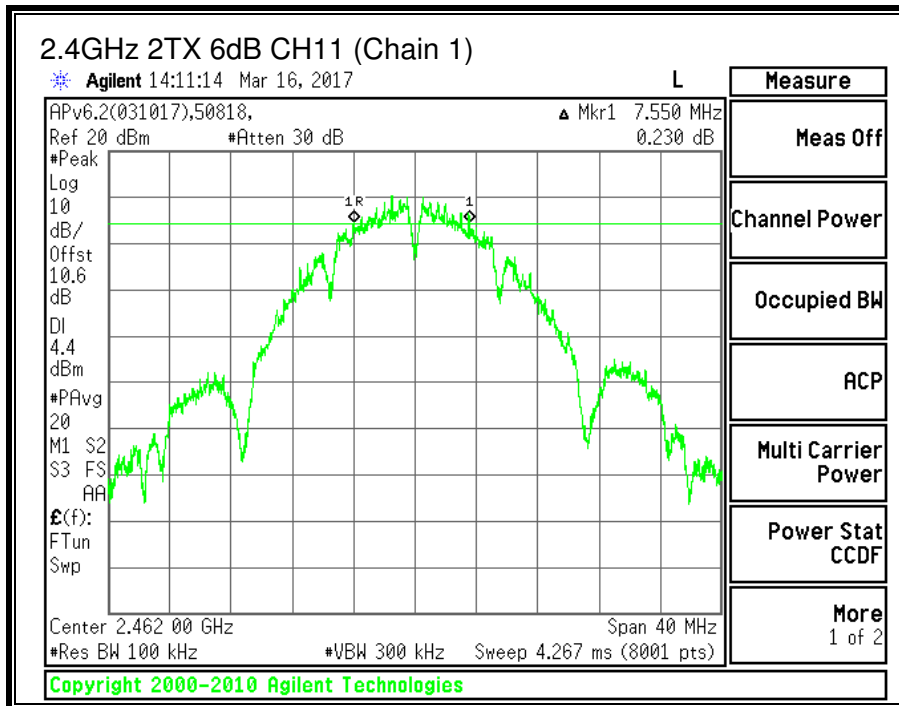
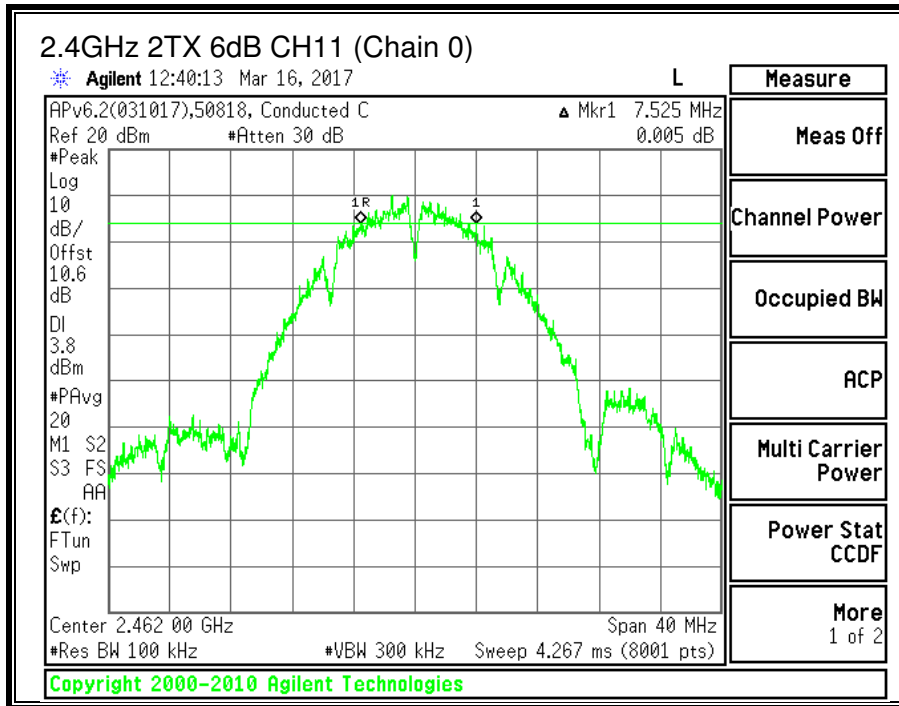

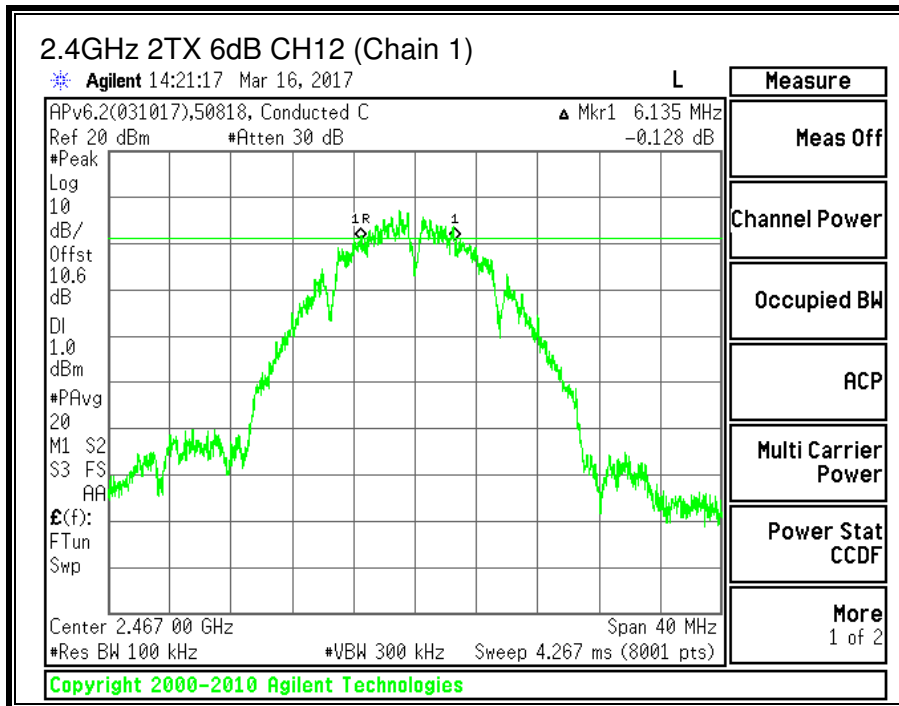
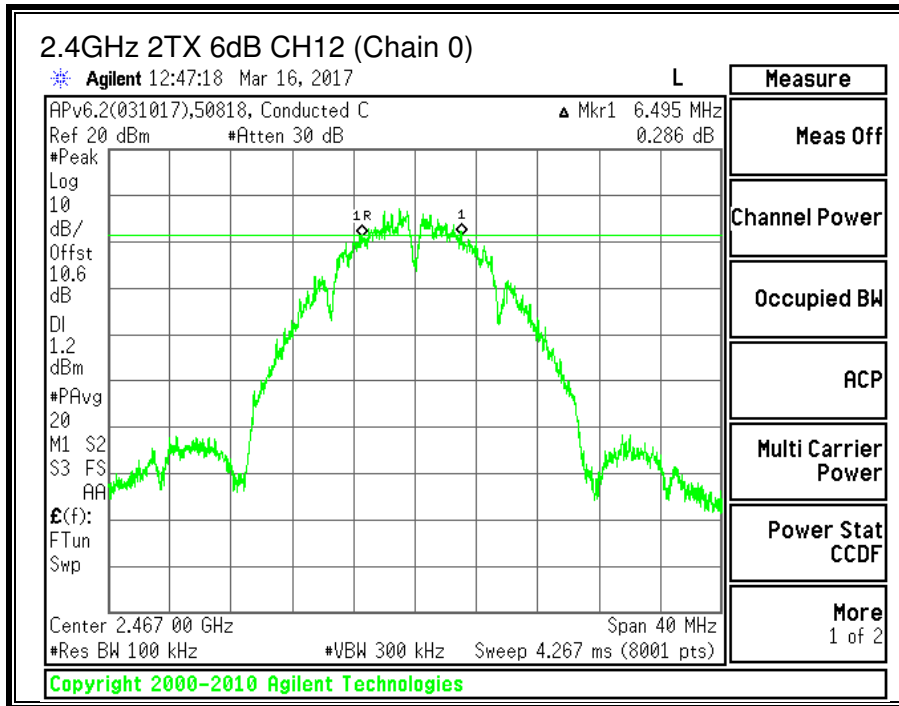

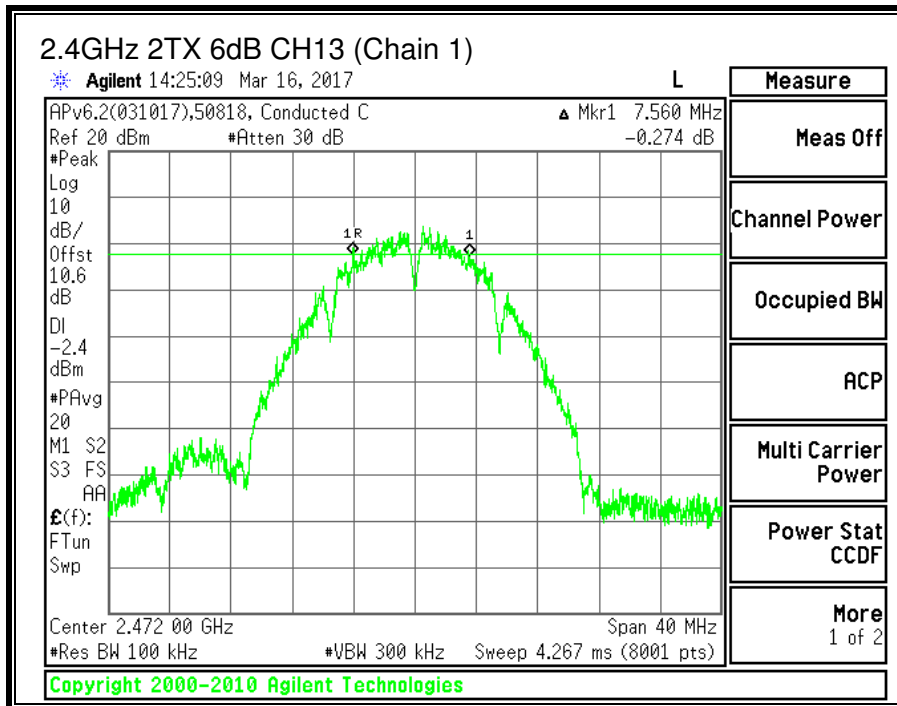
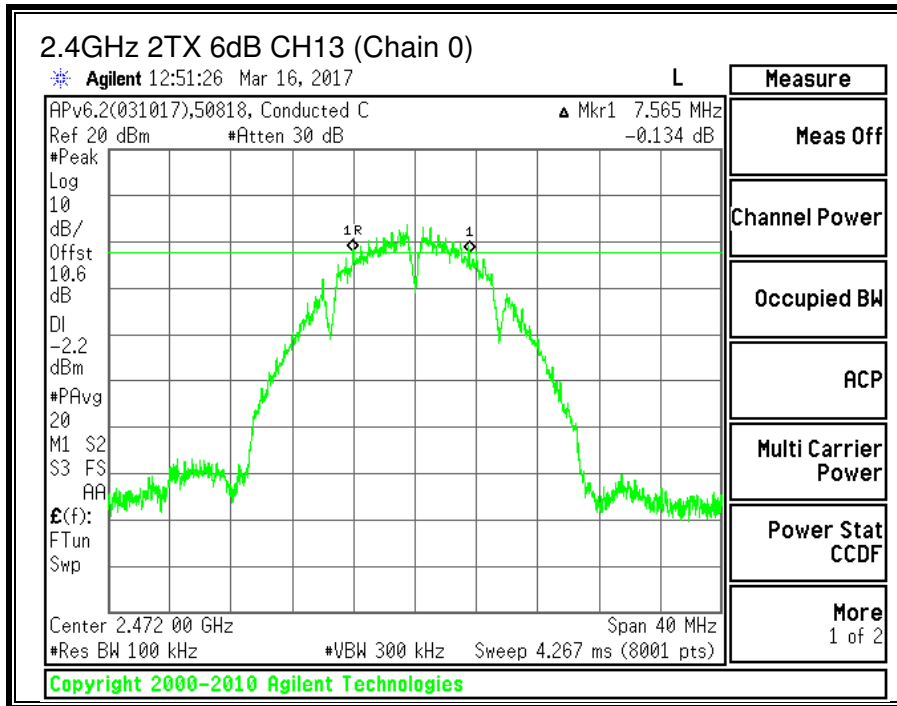

9.2.2. 99% BANDWIDTH

LIMITS

None; for reporting purposes only.

RESULTS

Channel	Frequency (MHz)	99% Bandwidth Chain 0 (MHz)	99% Bandwidth Chain 1 (MHz)
CH1	2412	13.2528	14.5015
CH6	2437	13.0595	14.5817
CH11	2462	12.9214	14.1385
CH12	2467	12.8266	12.8679
CH13	2472	12.8537	12.5773

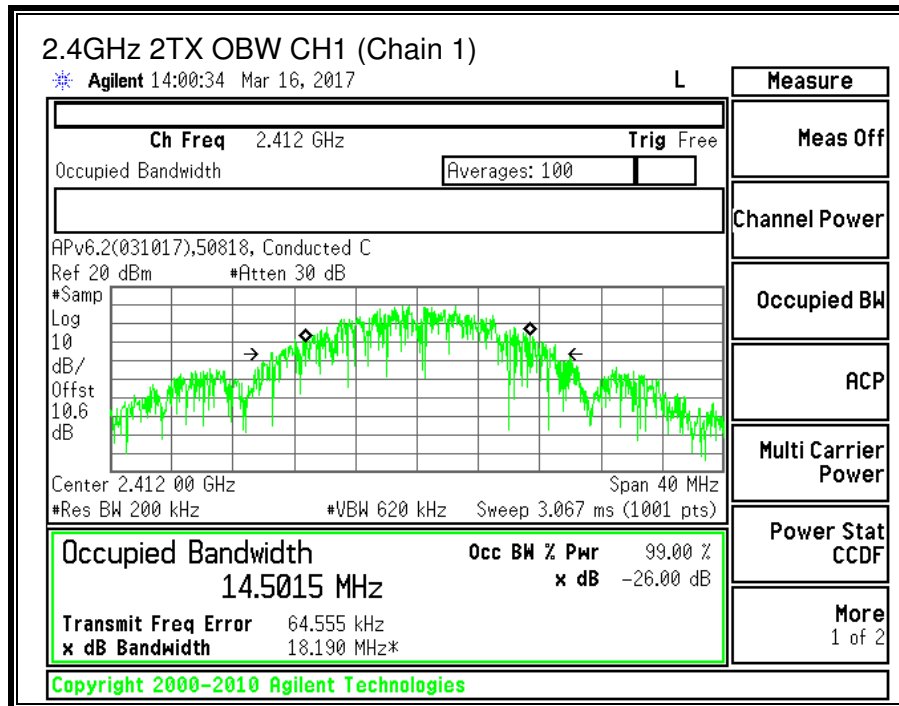
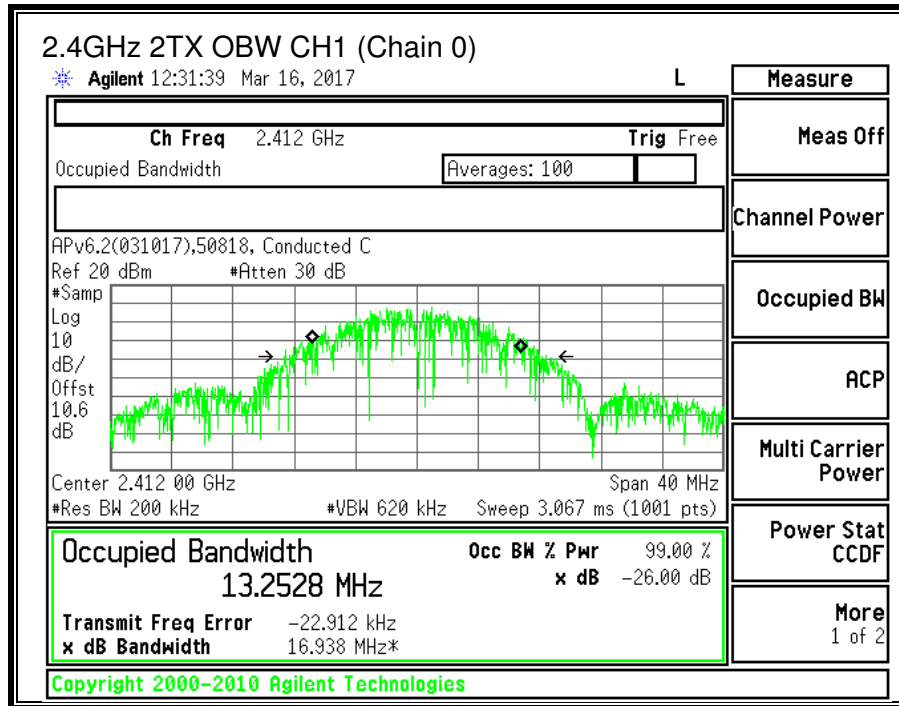

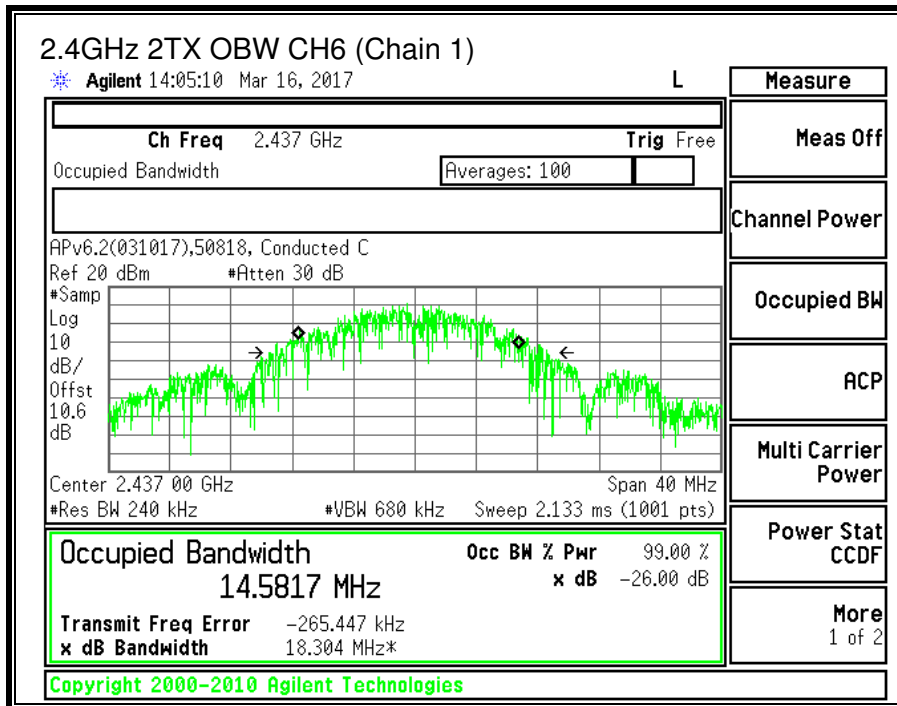
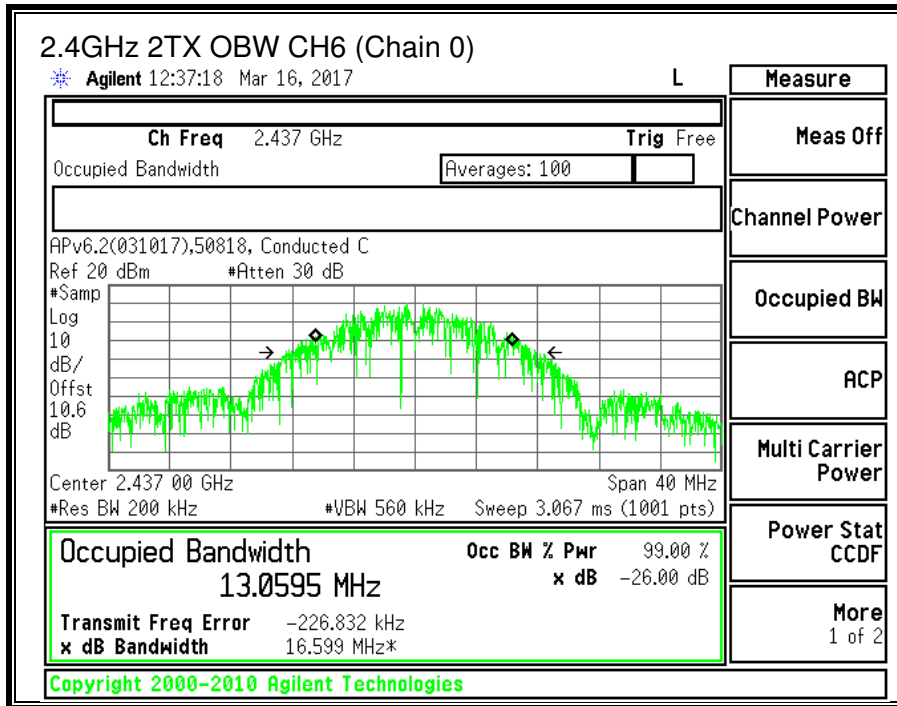

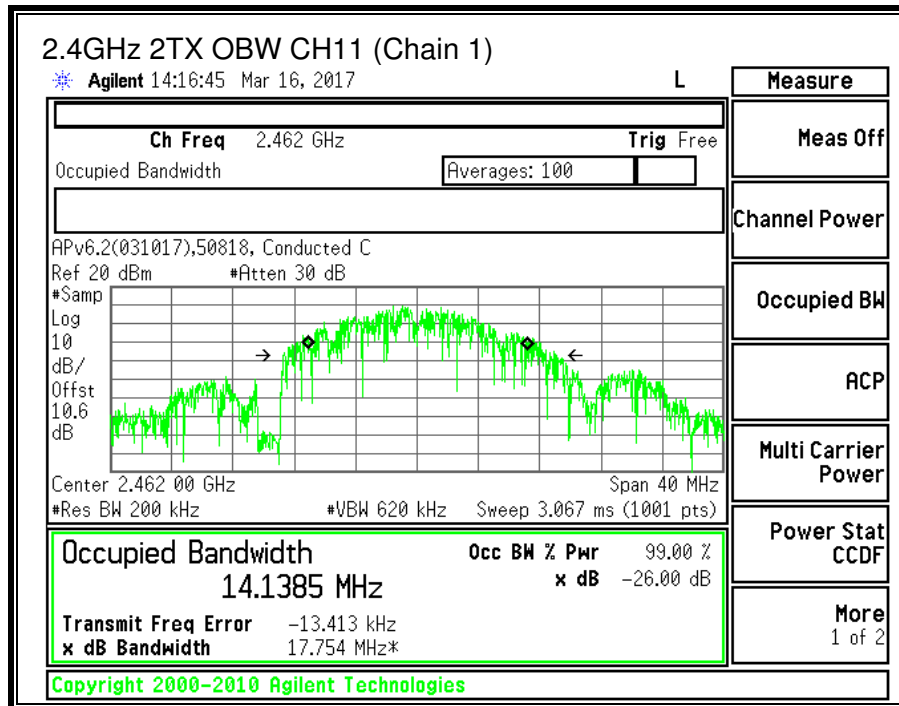
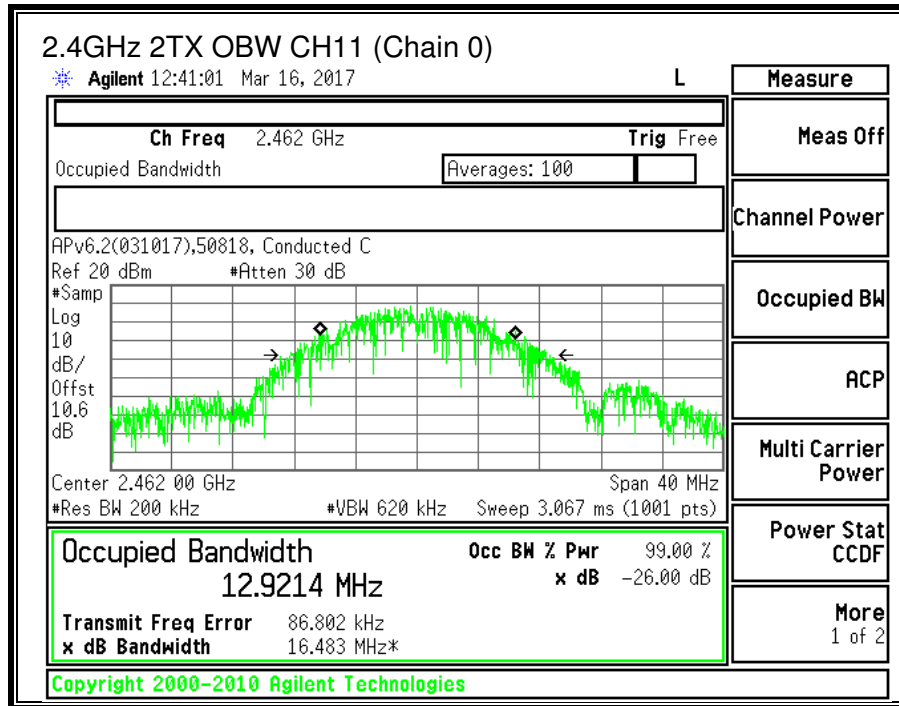

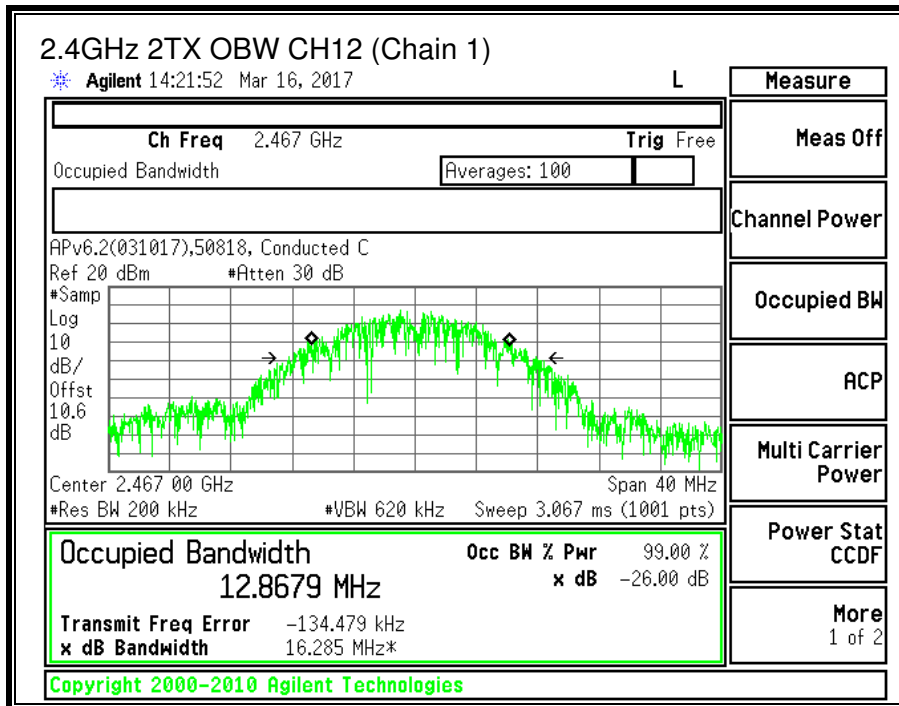
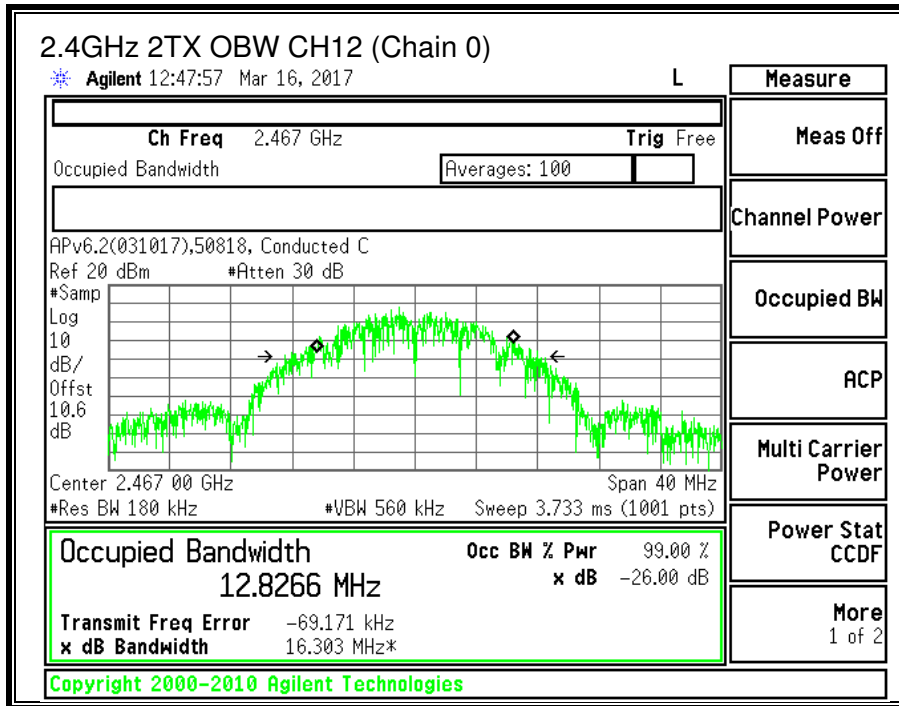

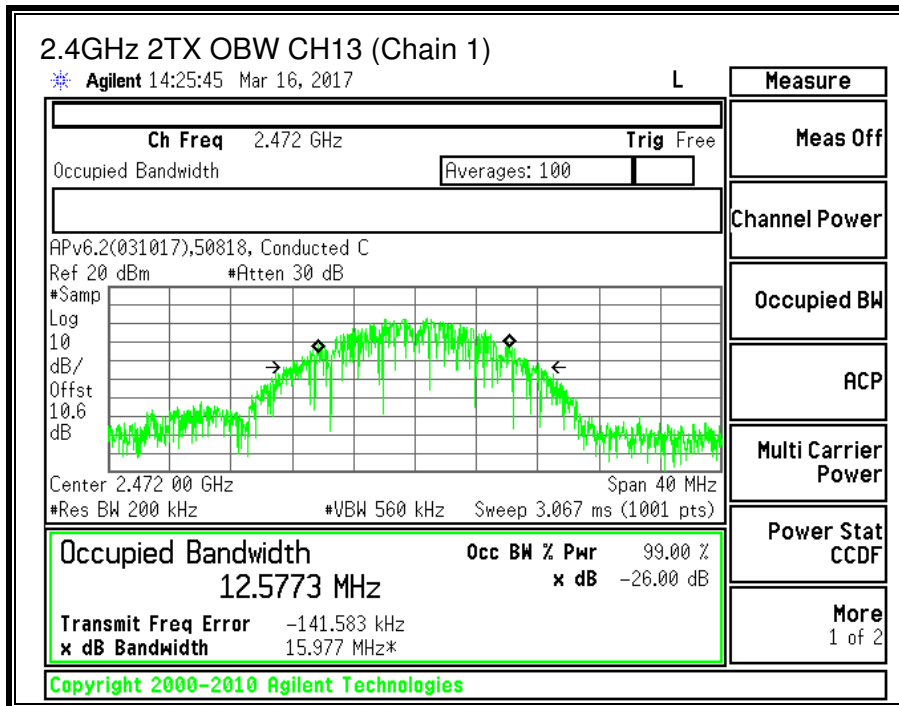
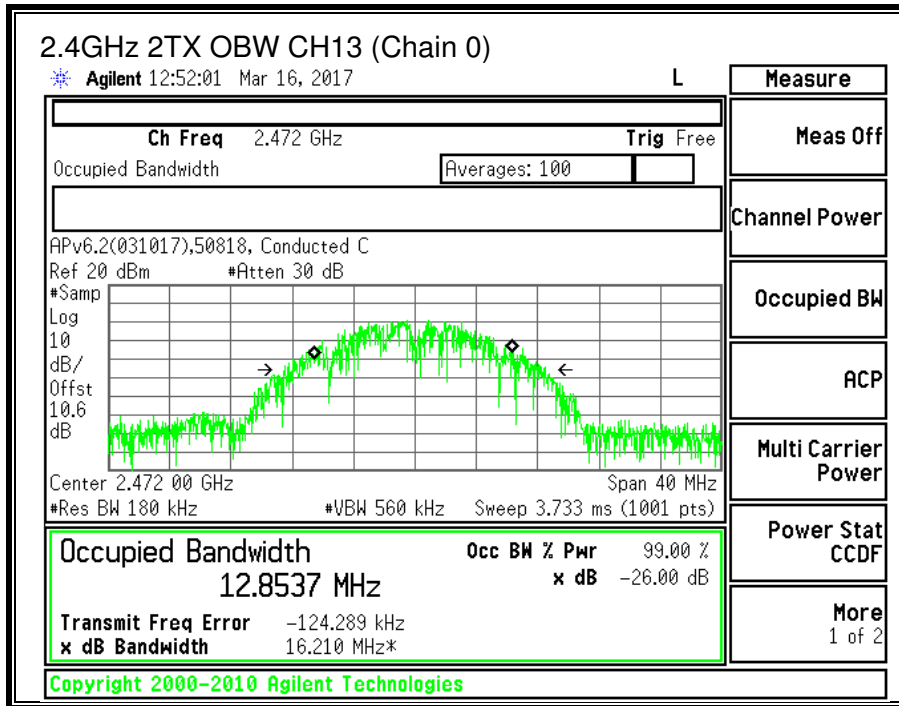

9.2.3. OUTPUT POWER

LIMITS

FCC §15.247 (b) (3)
IC RSS-247 (5.4) (4)

For systems using digital modulation in the 2400–2483.5 MHz, and 5725–5850 MHz bands: 1 Watt, based on the use of antennas with directional gains that do not exceed 6 dBi. If transmitting antennas of directional gain greater than 6 dBi are used, the conducted output power from the intentional radiator shall be reduced by the amount in dB that the directional gain of the antenna exceeds 6 dBi.

DIRECTIONAL ANTENNA GAIN

The TX chains are uncorrelated and the antenna gain is unequal among the chains. The directional gain is:

Chain 0 Antenna Gain (dBi)	Chain 1 Antenna Gain (dBi)	Uncorrelated Chains Directional Gain (dBi)
-5.20	-9.80	-6.92

TEST PROCEDURE

KDB 58074 D01 v03r05 Section 9.2.3.2

RESULTS

ID:	50818	Date:	03/17/2017
------------	-------	--------------	------------

Limits

Channel	Frequency (MHz)	Directional Gain (dBi)	FCC Power Limit (dBm)	IC Power Limit (dBm)	IC EIRP Limit (dBm)	Max Power (dBm)
CH1	2412	-6.92	30.00	30	36	30.00
CH6	2437	-6.92	30.00	30	36	30.00
CH11	2462	-6.92	30.00	30	36	30.00
CH12	2467	-6.92	30.00	30	36	30.00
CH13	2472	-6.92	30.00	30	36	30.00

Results

Channel	Frequency (MHz)	Core 0 Meas Power (dBm)	Core 1 Meas Power (dBm)	Total Corr'd Power (dBm)	Power Limit (dBm)	Margin (dB)
CH1	2412	17.59	19.39	21.59	30.00	-8.41
CH6	2437	18.25	19.12	21.72	30.00	-8.28
CH11	2462	18.52	18.66	21.60	30.00	-8.40
CH12	2467	15.92	15.71	18.83	30.00	-11.17
CH13	2472	12.06	12.63	15.36	30.00	-14.64

9.2.4. POWER SPECTRAL DENSITY

LIMITS

FCC §15.247 (e)
 IC RSS-247 (5.2) (2)

For digitally modulated systems, the power spectral density conducted from the intentional radiator to the antenna shall not be greater than 8 dBm in any 3 KHz band during any time interval of continuous transmissions.

RESULTS

Duty Cycle CF (dB)	0.00	Included in Calculations of Corr'd PSD
--------------------	------	--

PSD Results

Channel	Frequency (MHz)	Chain 0 Meas (dBm)	Chain 1 Meas (dBm)	Total Corr'd PSD (dBm)	Limit (dBm)	Margin (dB)
CH1	2412	-4.088	-2.495	-0.21	8.0	-8.2
CH6	2437	-2.994	-2.597	0.22	8.0	-7.8
CH11	2462	-2.873	-2.786	0.18	8.0	-7.8
CH12	2467	-5.811	-5.753	-2.77	8.0	-10.8
CH13	2472	-9.697	-8.987	-6.32	8.0	-14.3

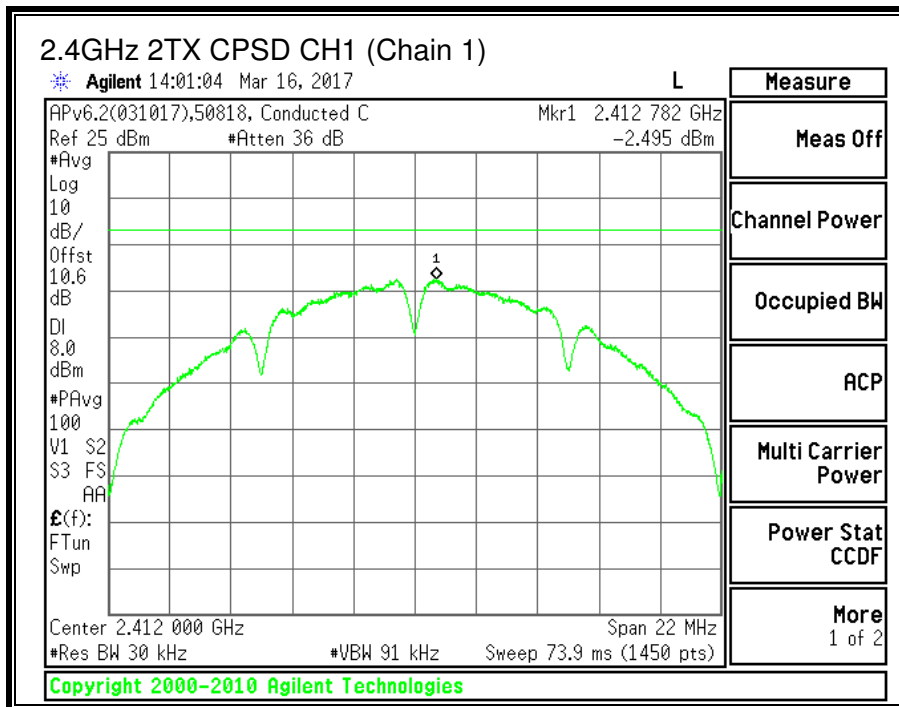
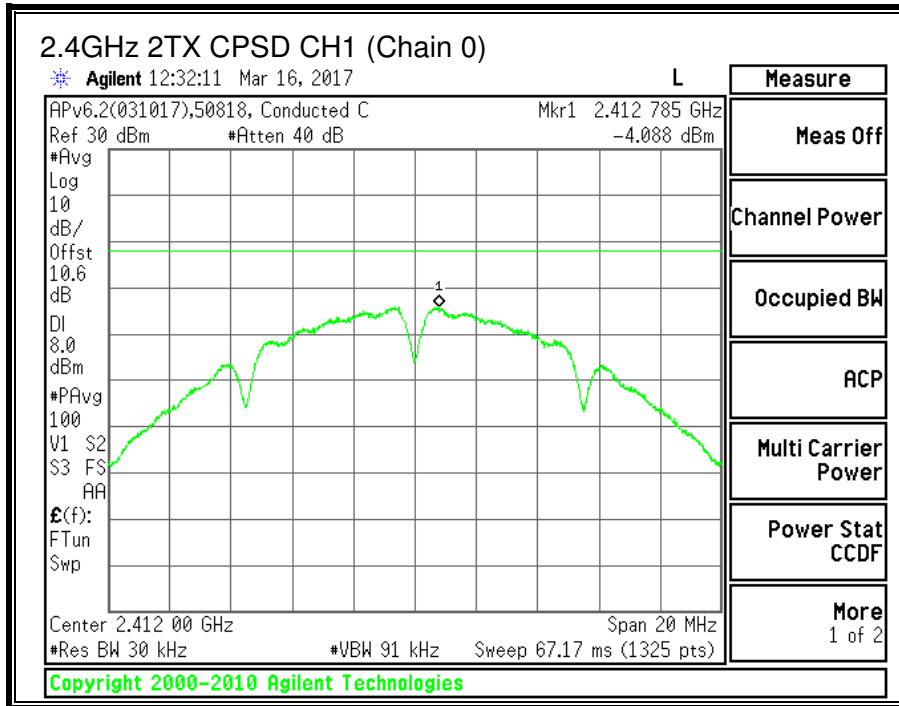

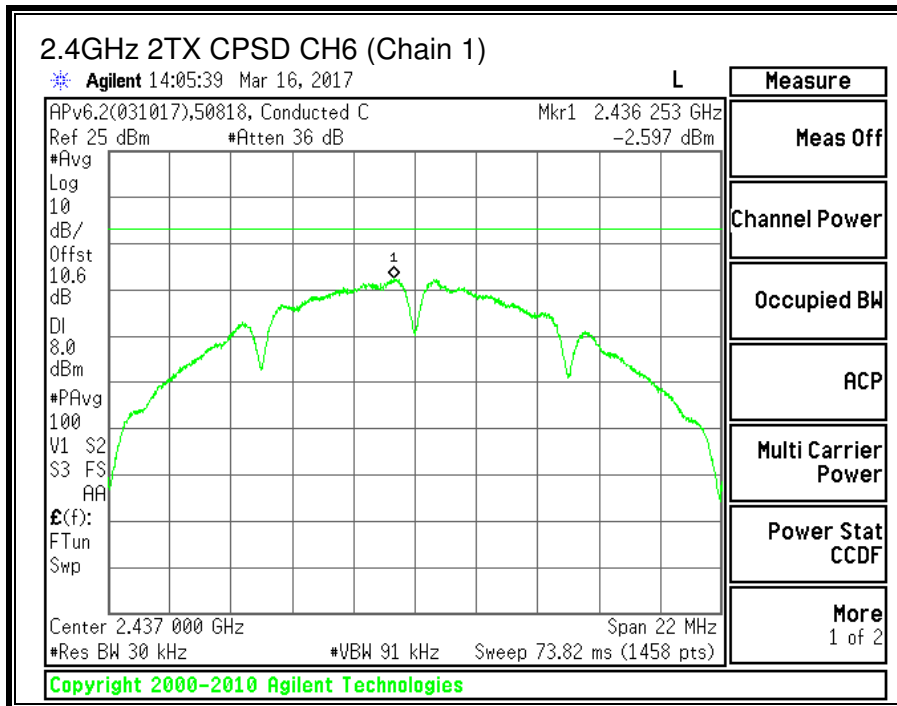
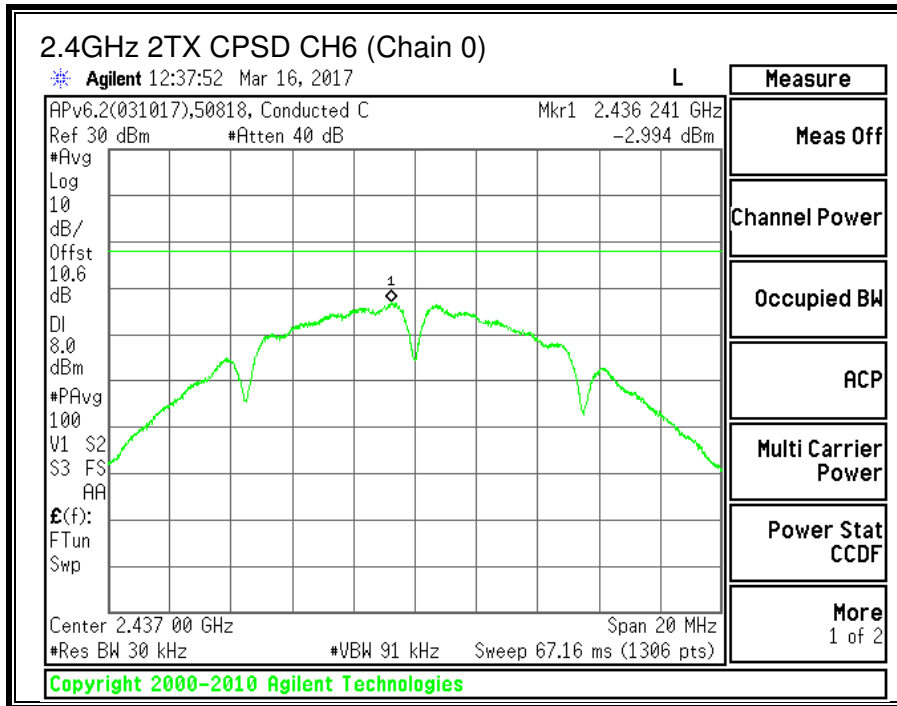

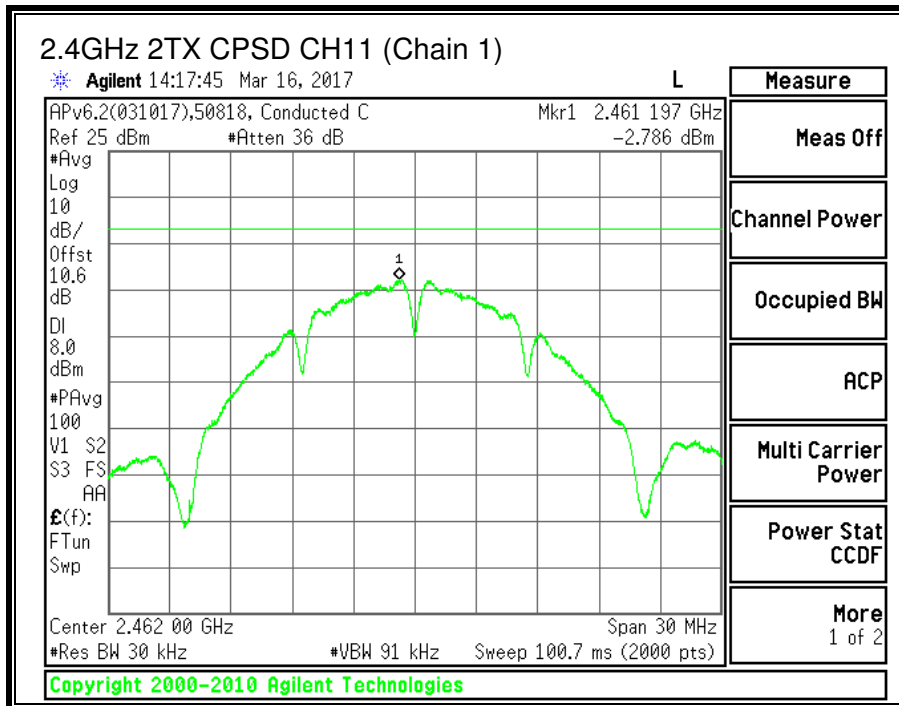
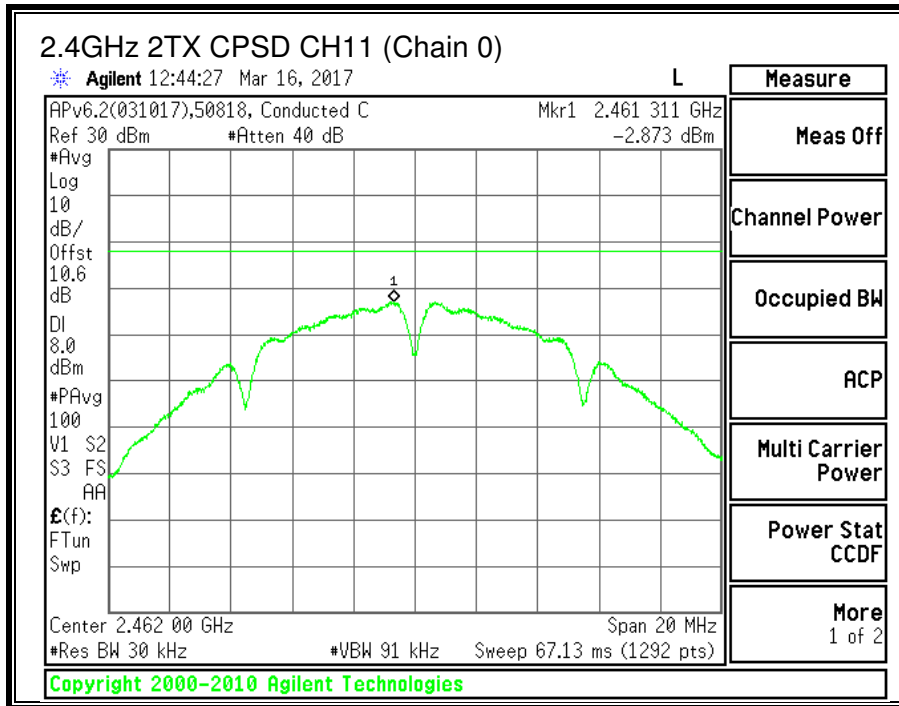

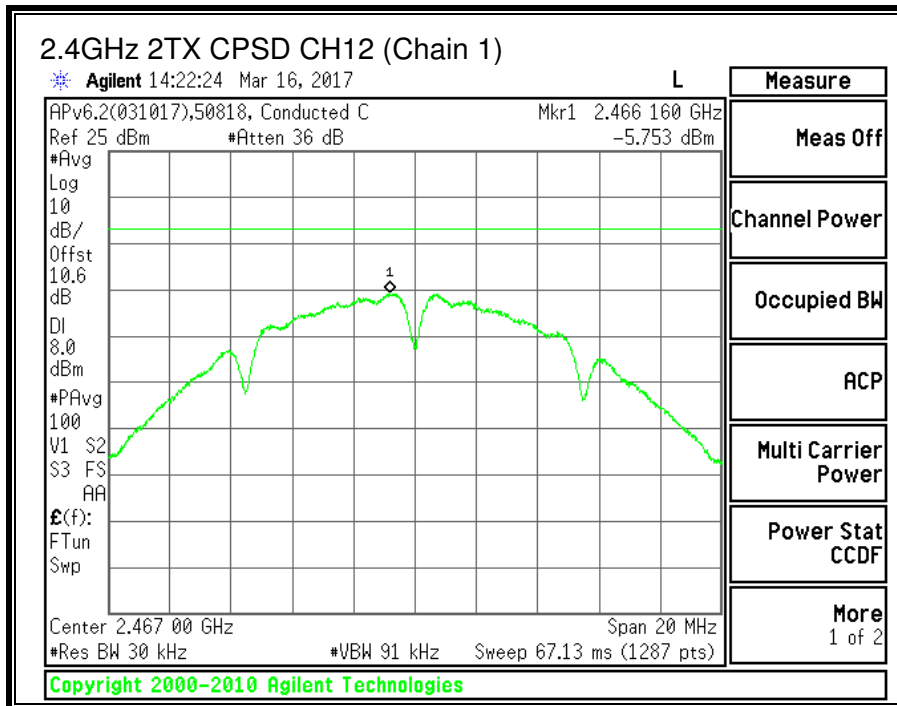
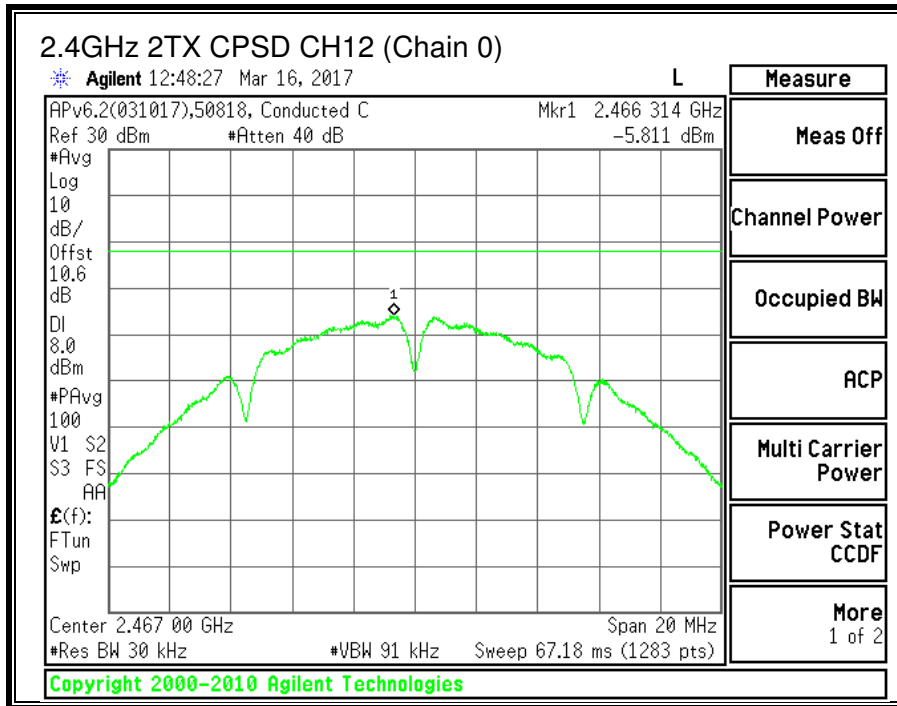

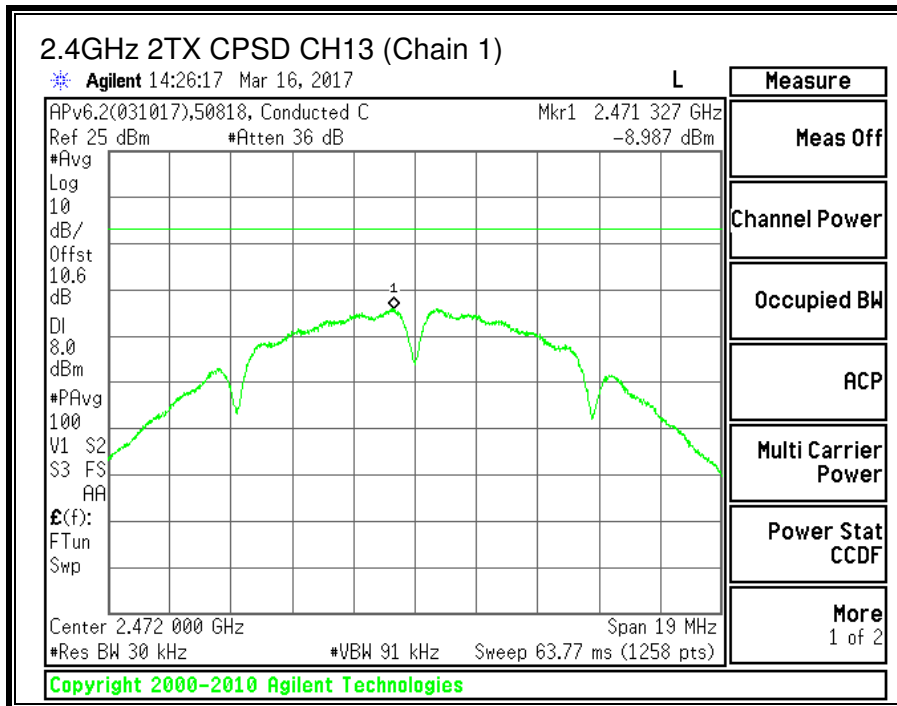
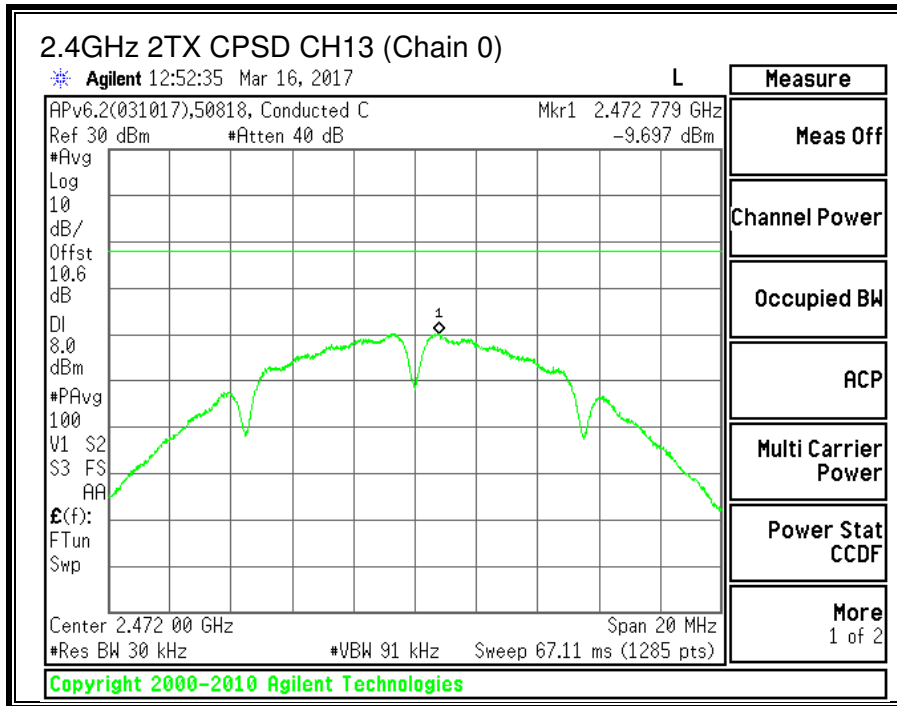

9.2.5. CONDUCTED BANEDGE AND SPURIOUS EMISSIONS

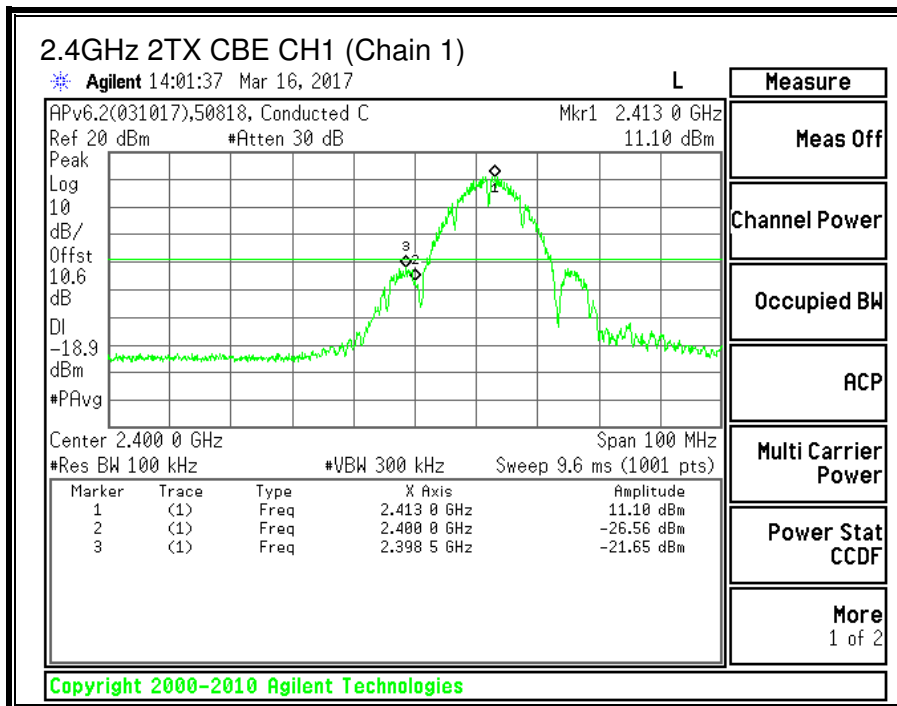
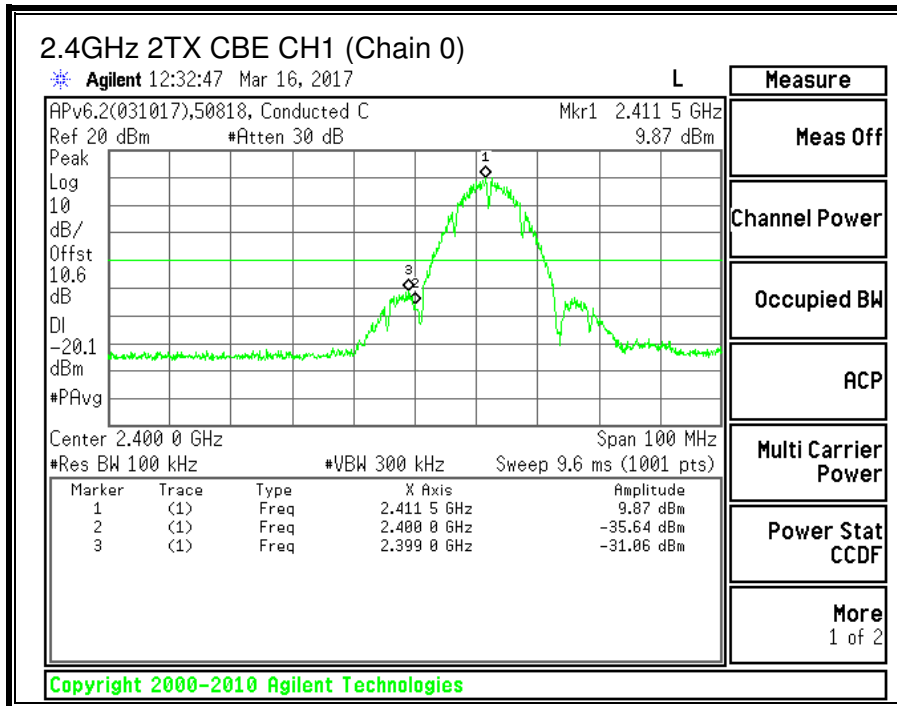

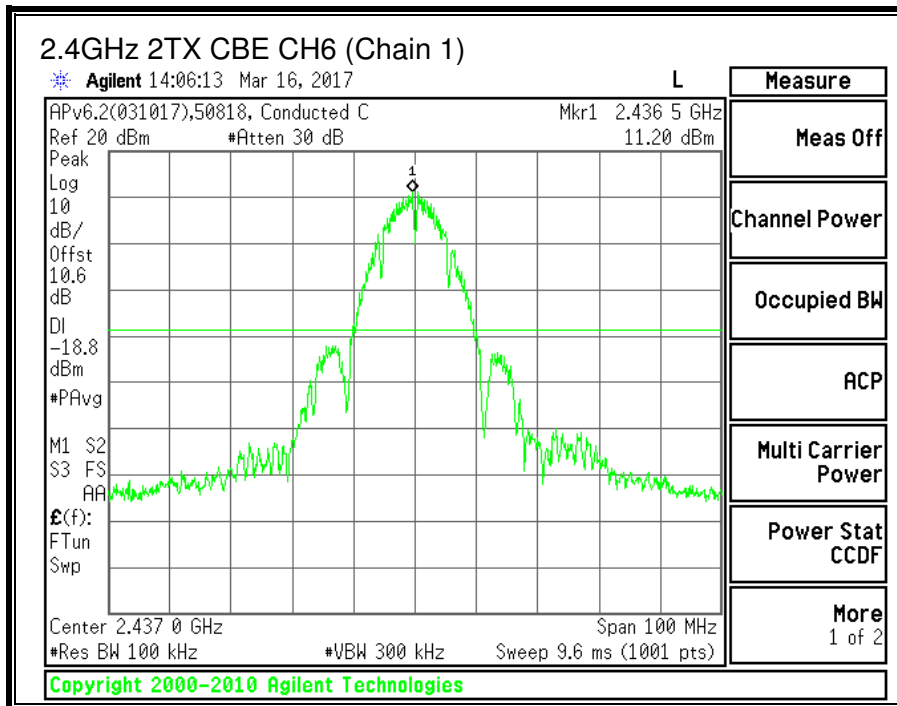
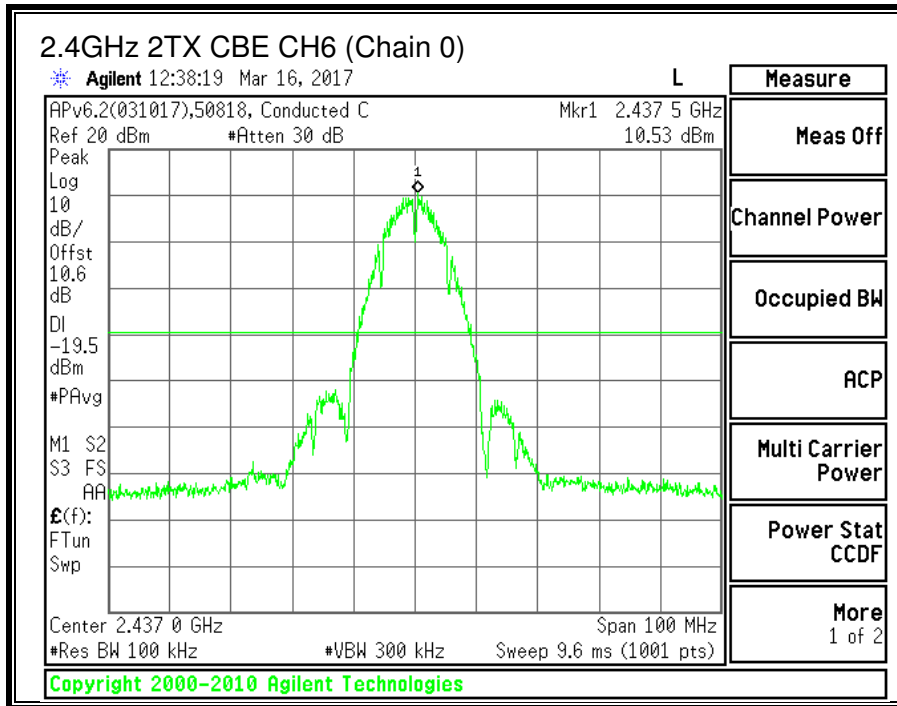

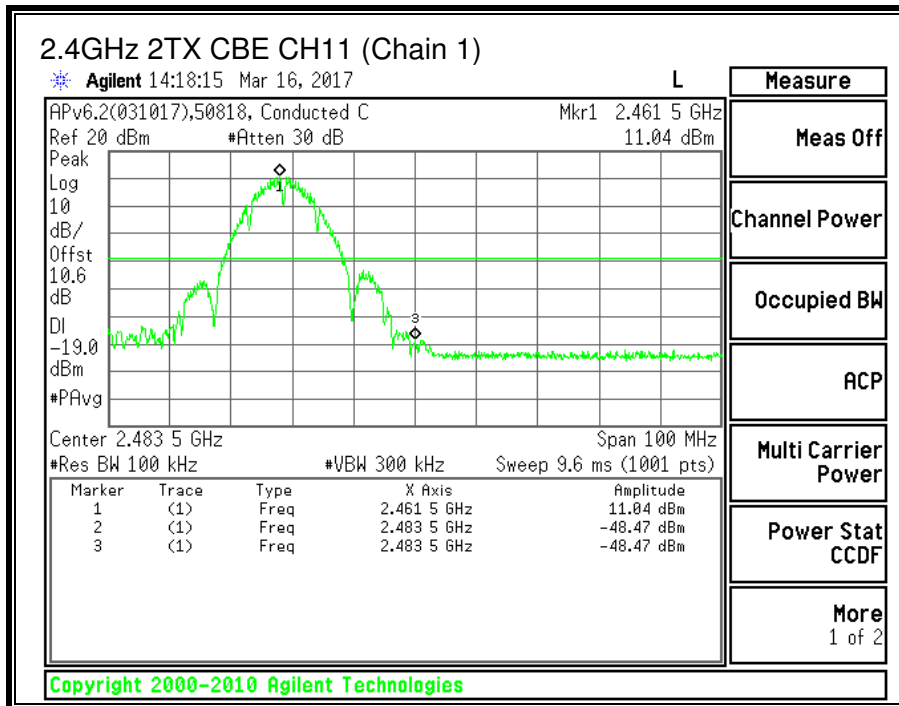
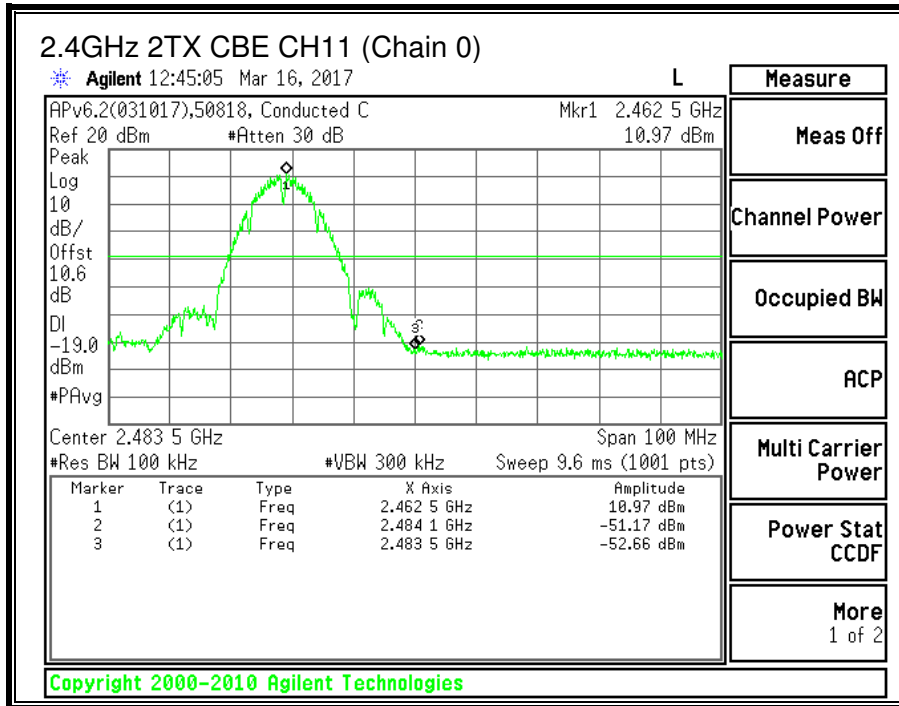

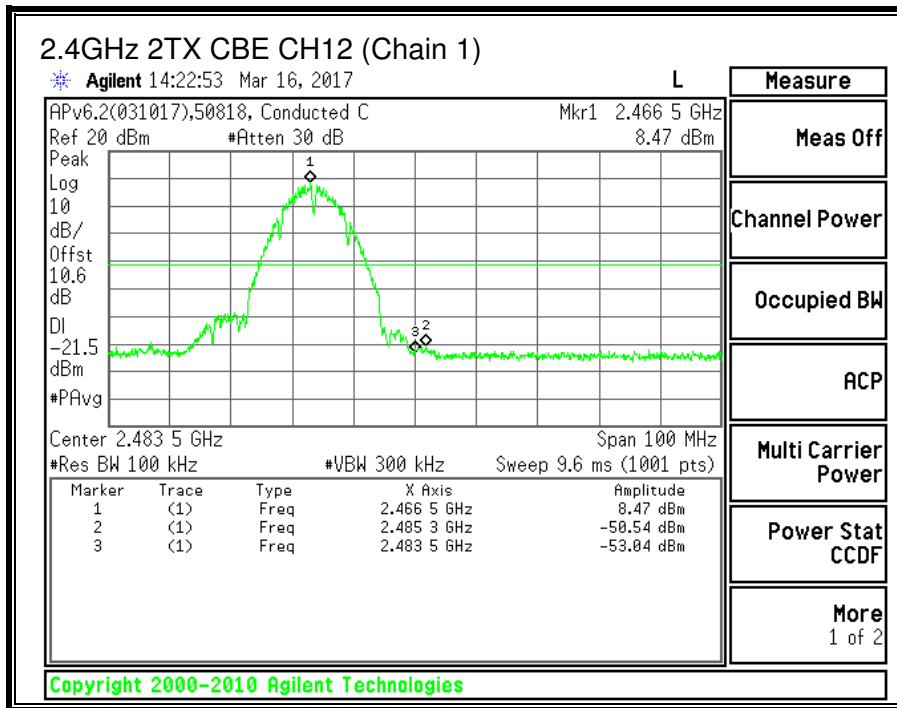
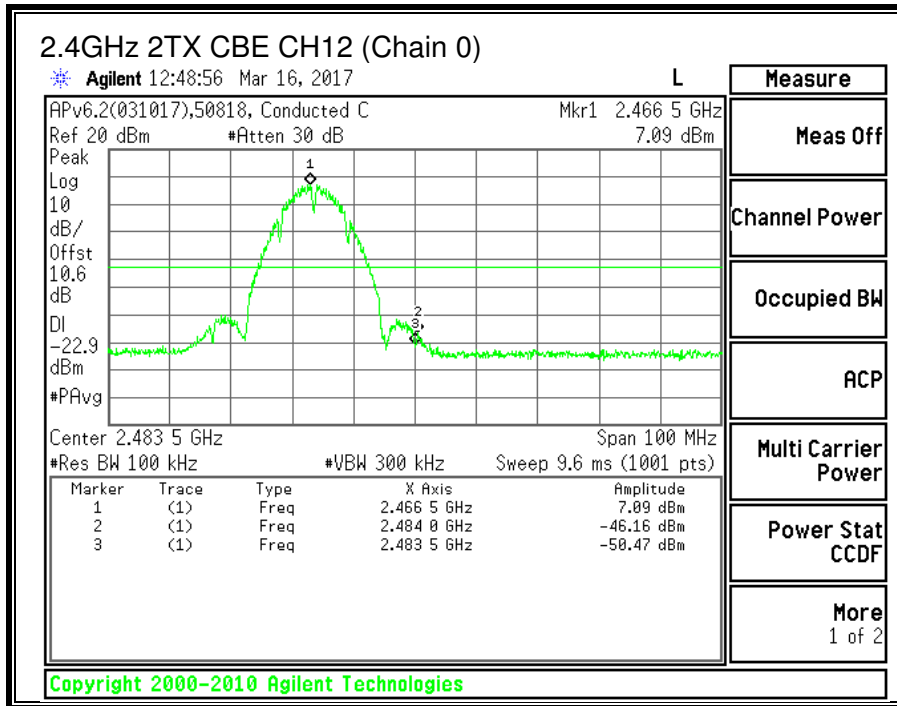

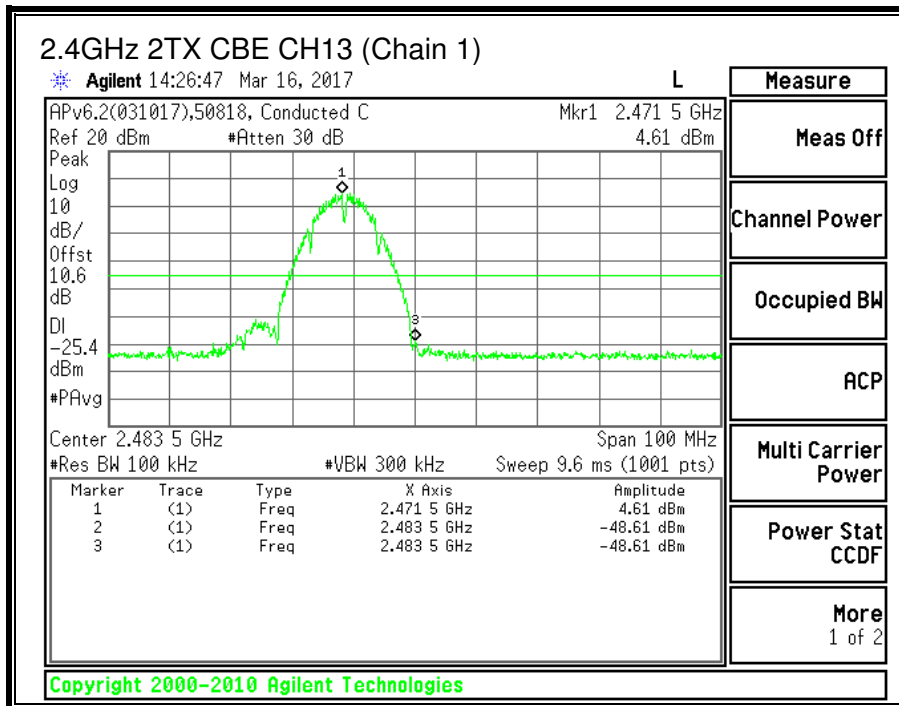
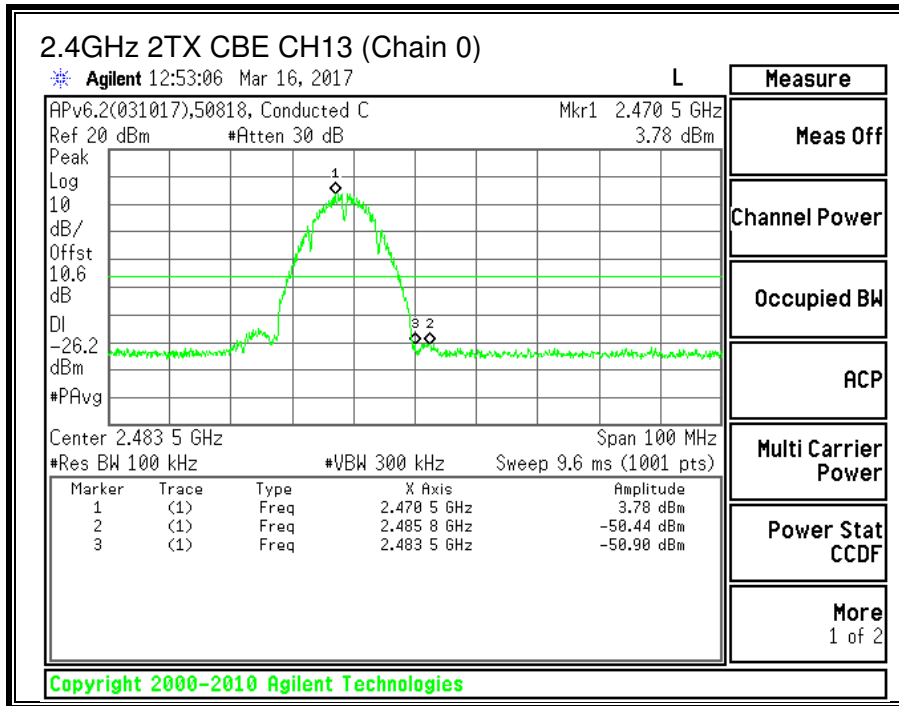

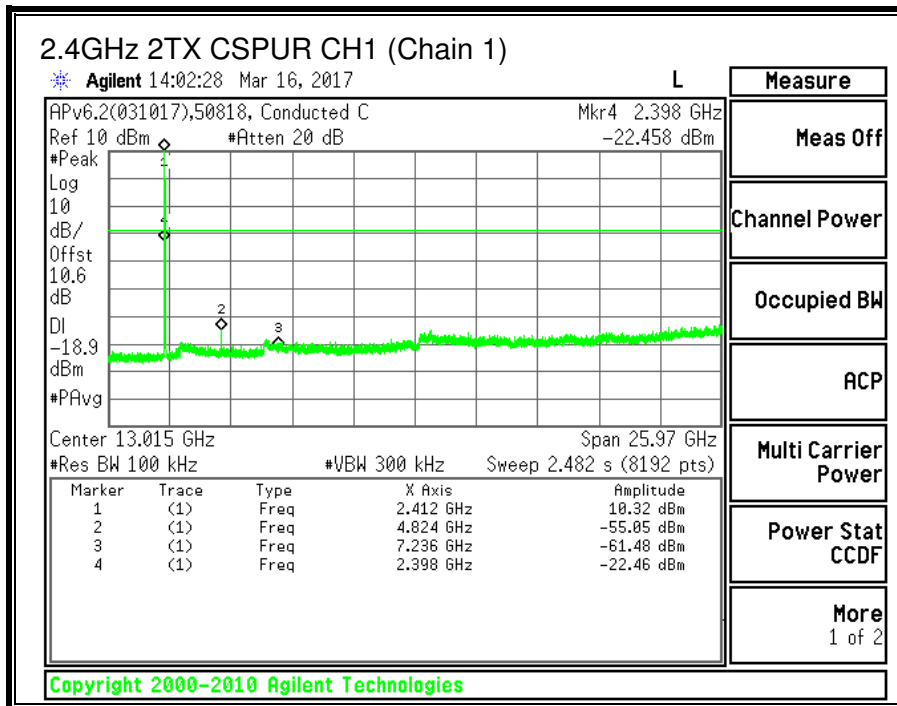
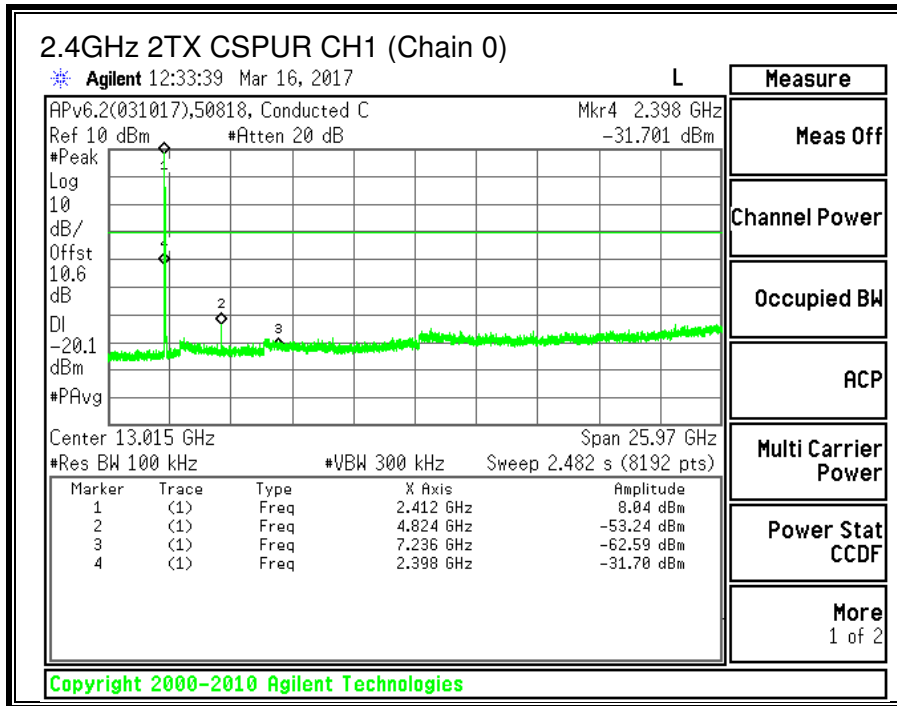

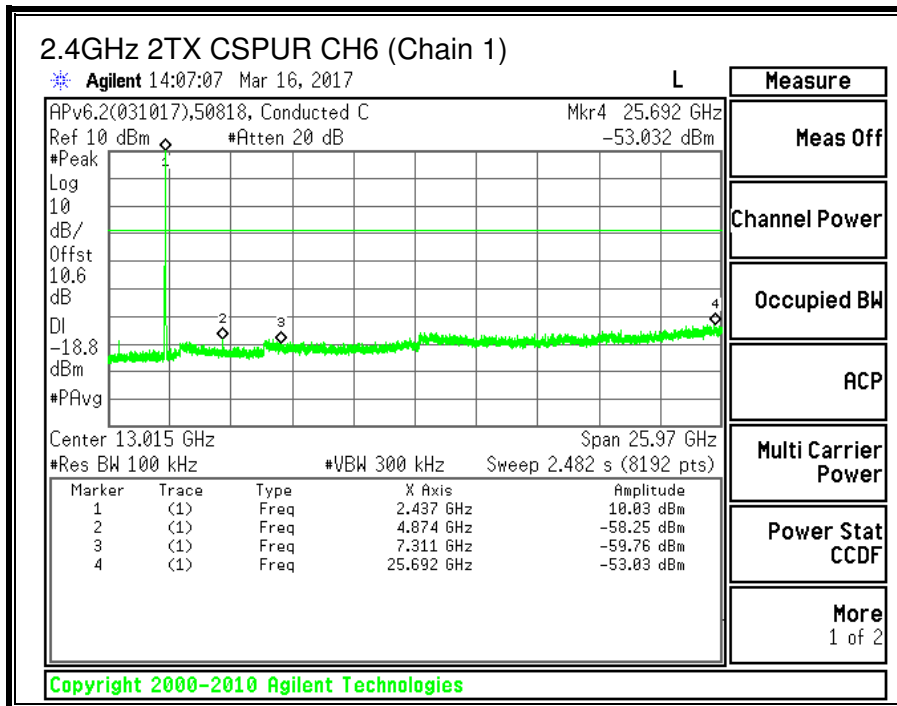
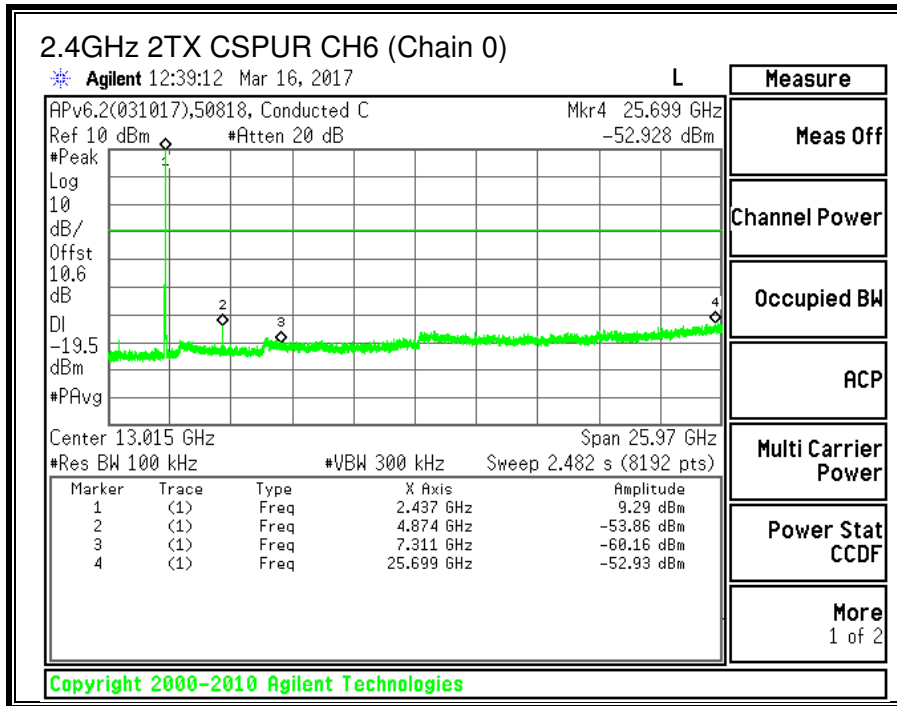

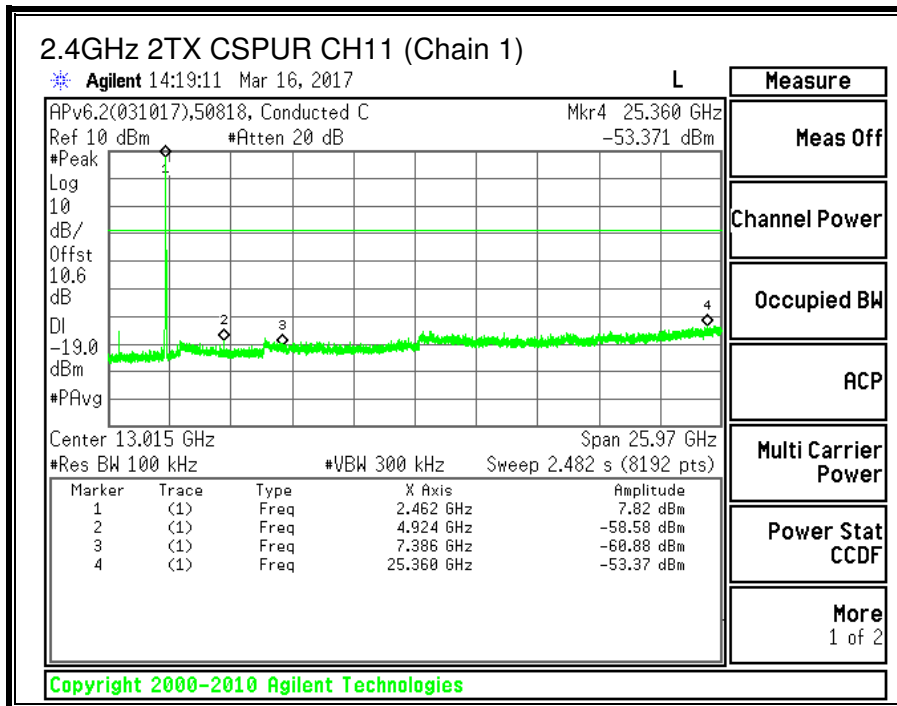
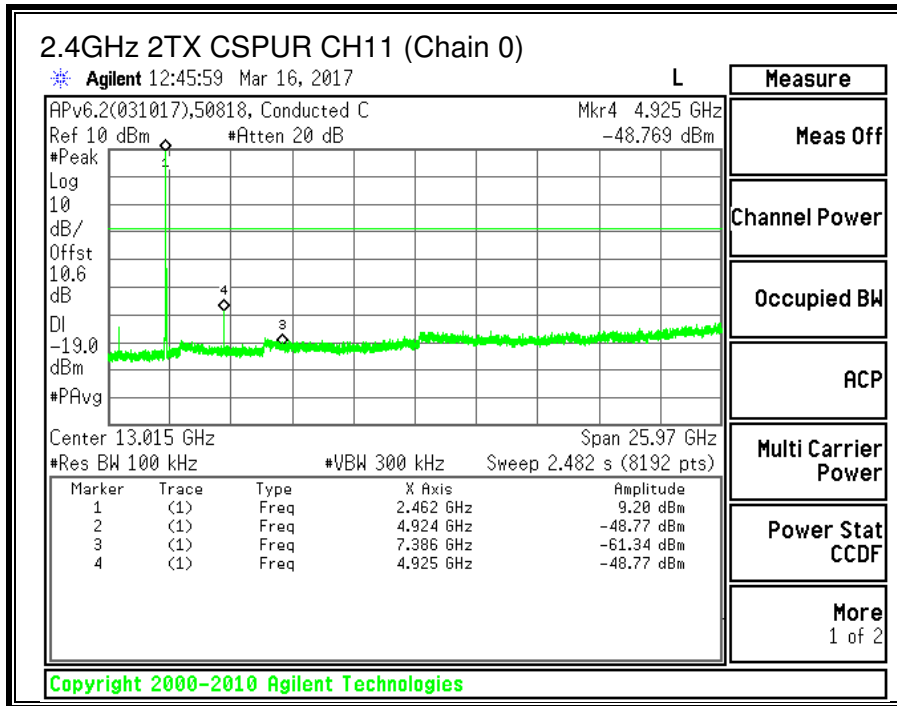

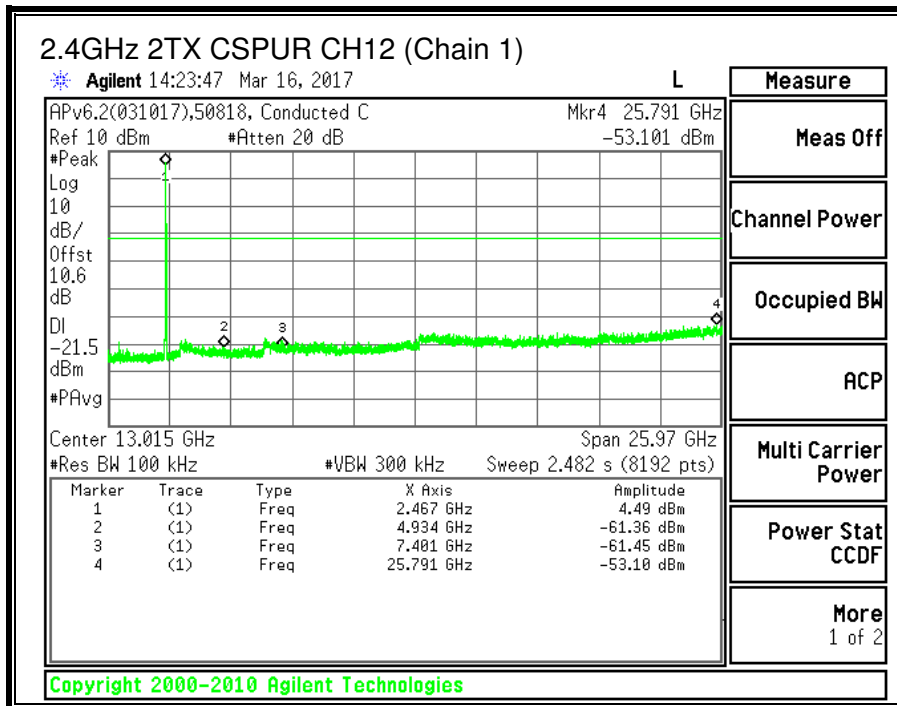
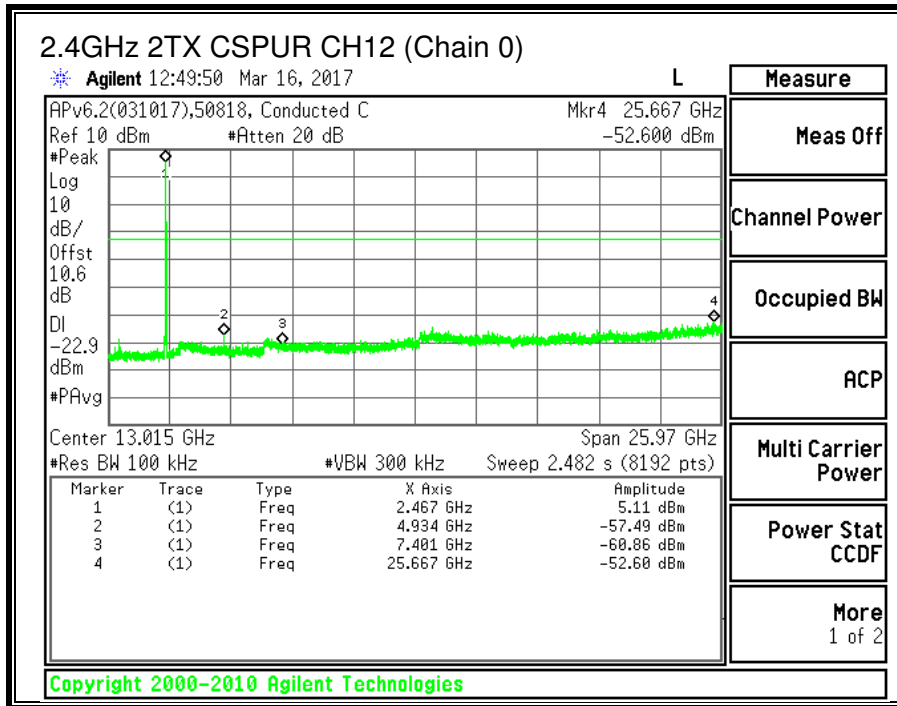

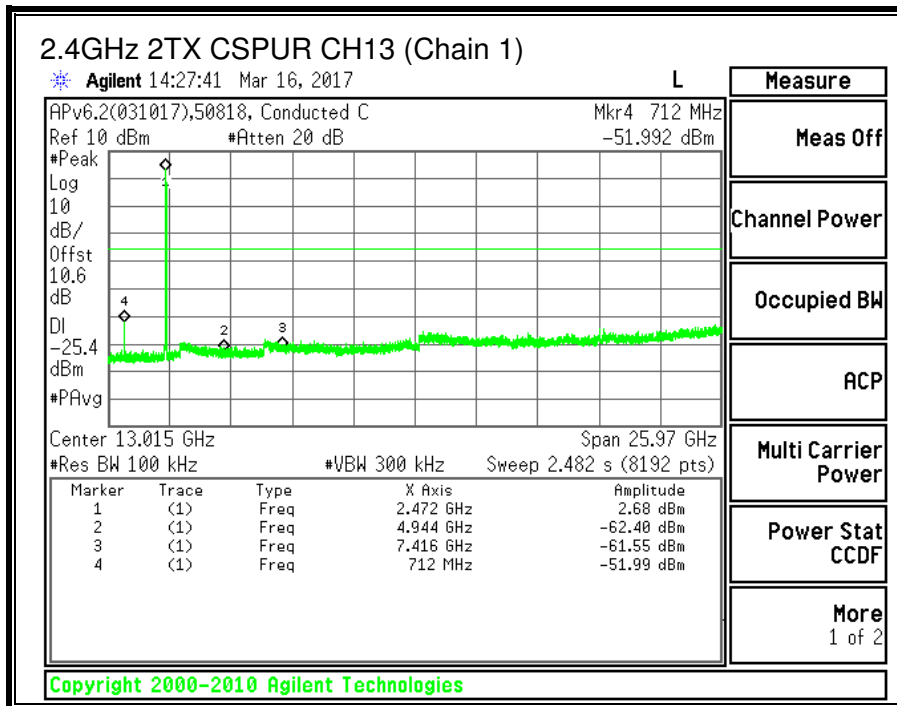
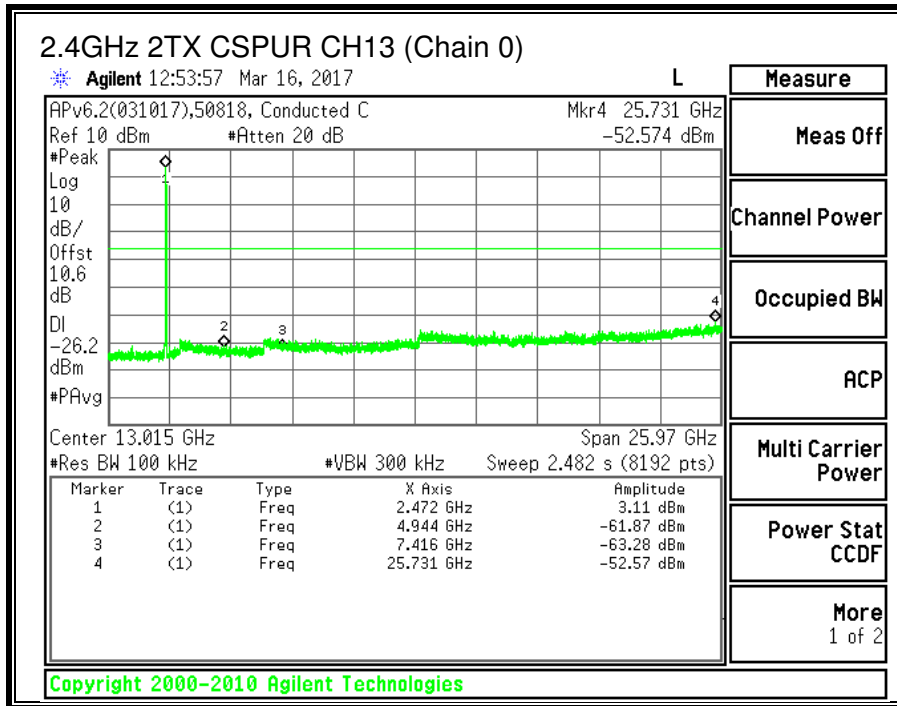

9.3. 11g 2TX CDD MIMO MODE IN THE 2.4GHZ BAND

9.3.1. 6 dB BANDWIDTH

LIMITS

FCC §15.247 (a) (2)
IC RSS-247 (5.2) (1)

The minimum 6 dB bandwidth shall be at least 500 kHz.

RESULTS

Channel	Frequency	6 dB BW Chain 0 (MHz)	6 dB BW Chain 1 (MHz)	Minimum Limit (MHz)
CH1	2412	16.315	16.375	0.5
CH2	2417	16.395	16.390	0.5
CH3	2422	16.360	16.355	0.5
CH6	2437	16.460	16.395	0.5
CH10	2457	16.315	16.375	0.5
CH11	2462	16.300	15.715	0.5
CH12	2467	16.305	16.415	0.5
CH13	2472	15.705	15.915	0.5

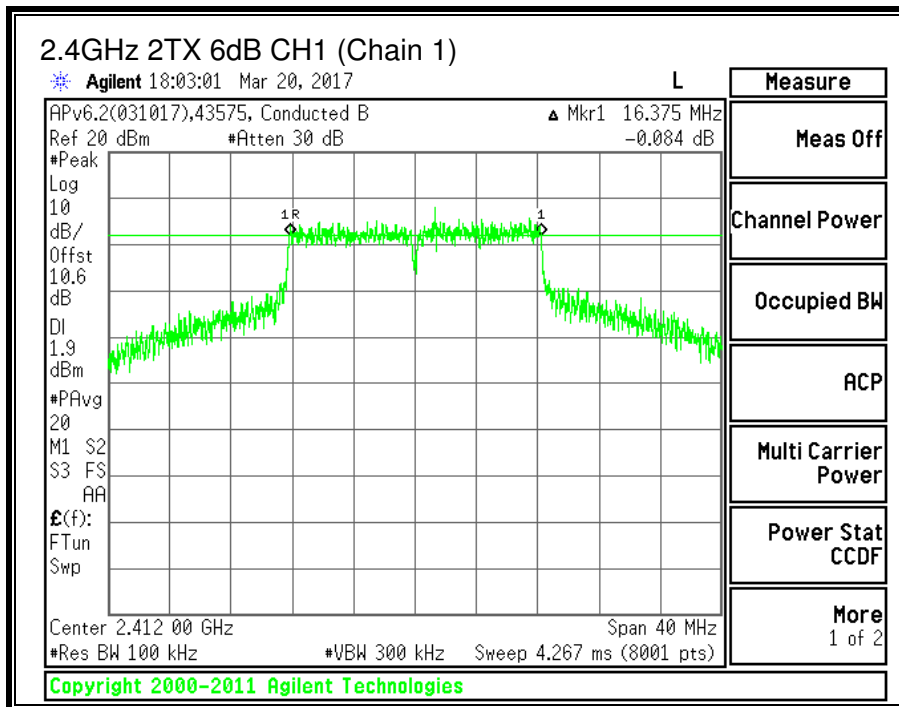
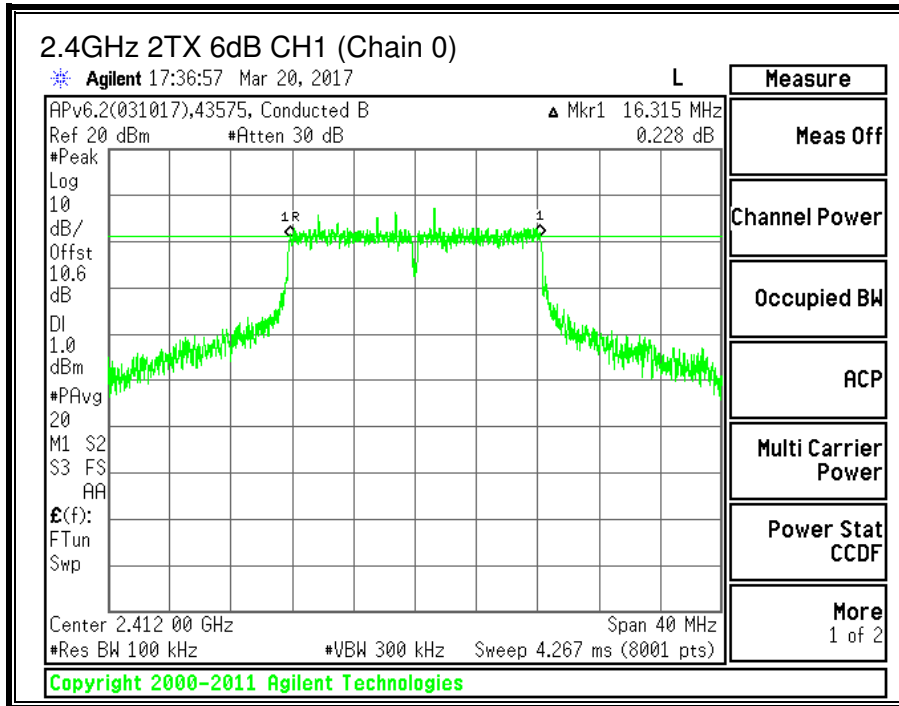

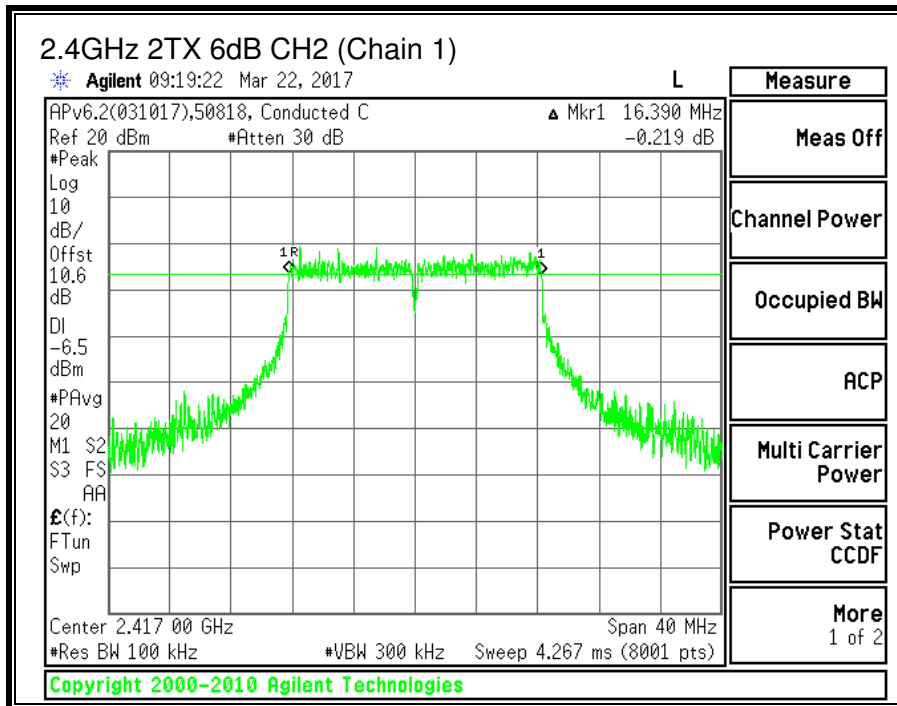
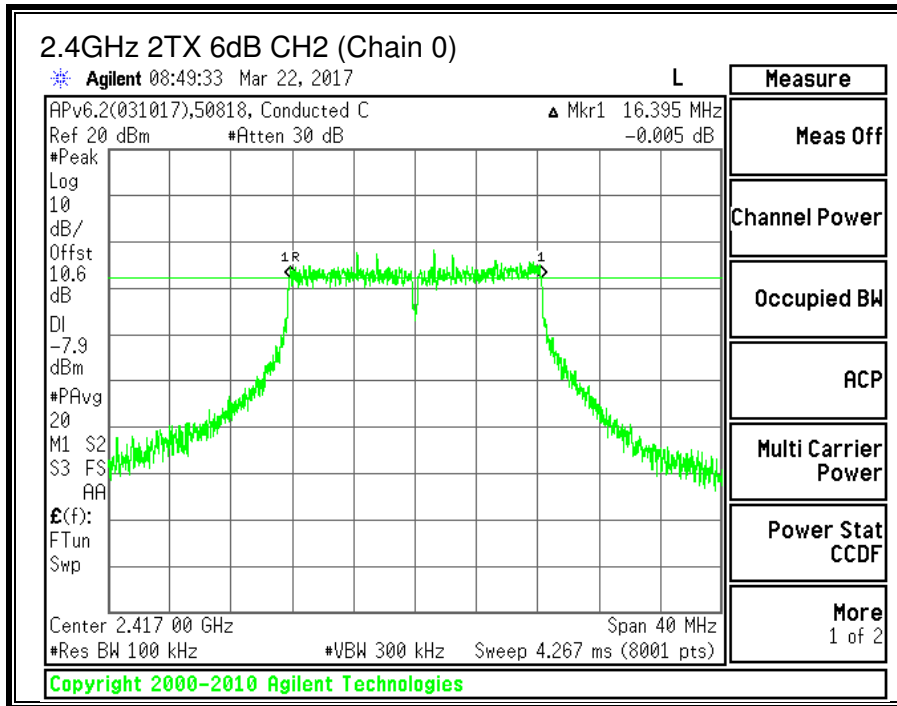

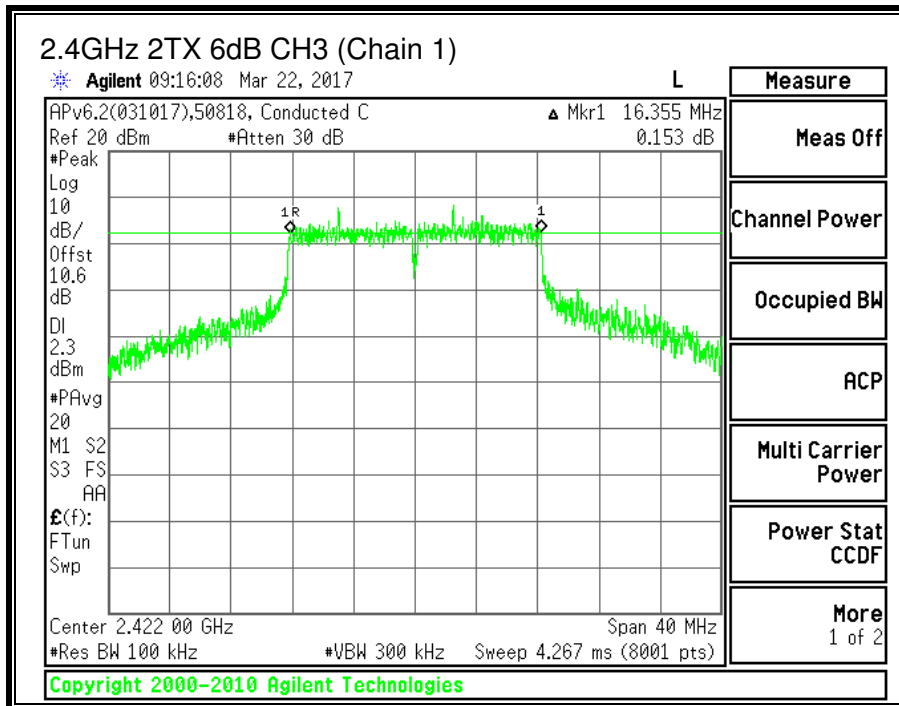
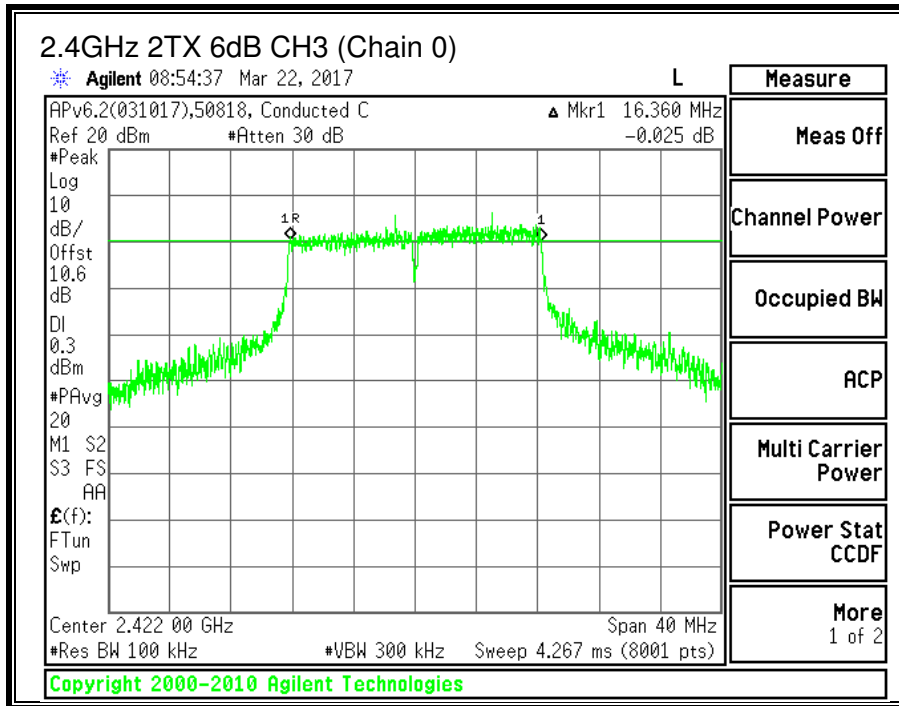

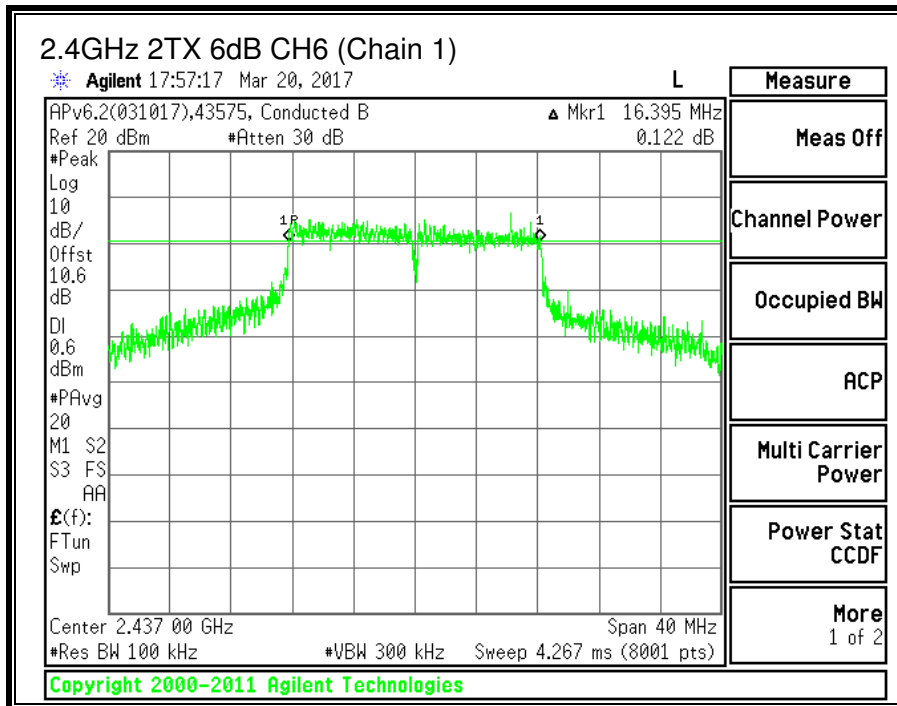
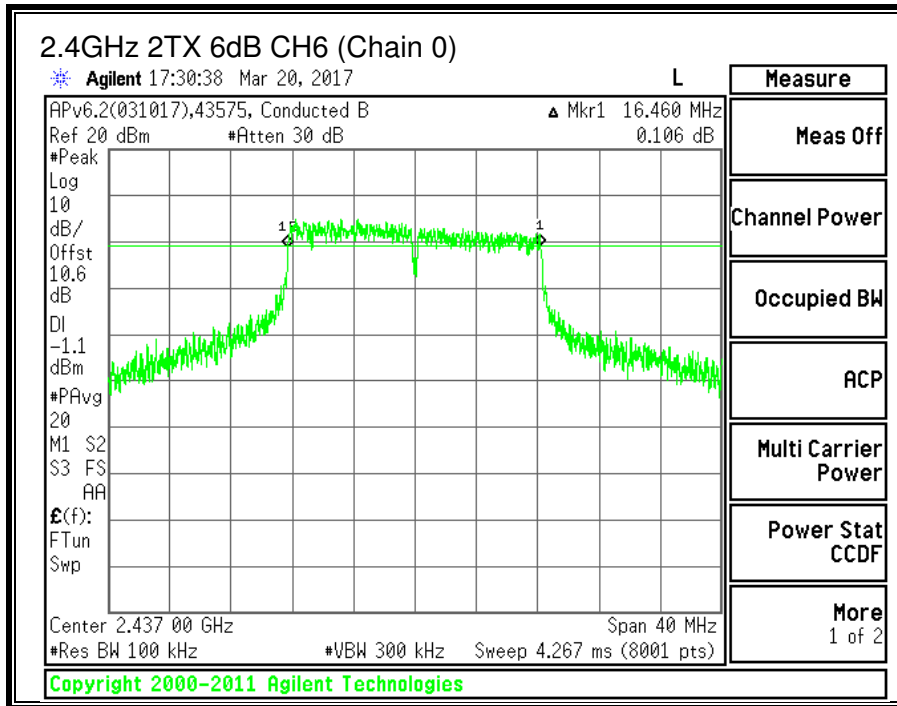

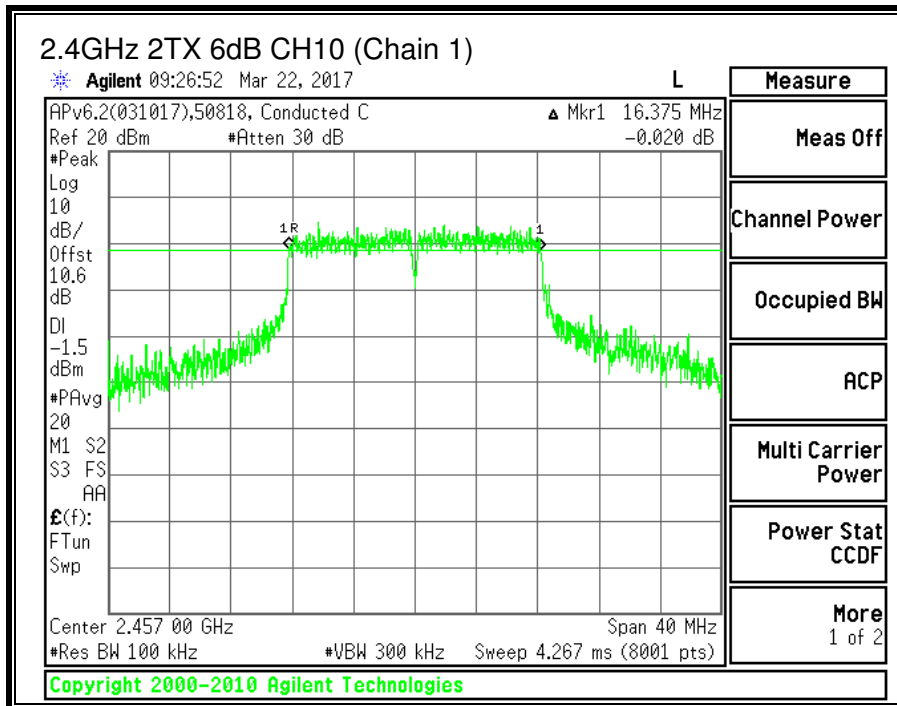
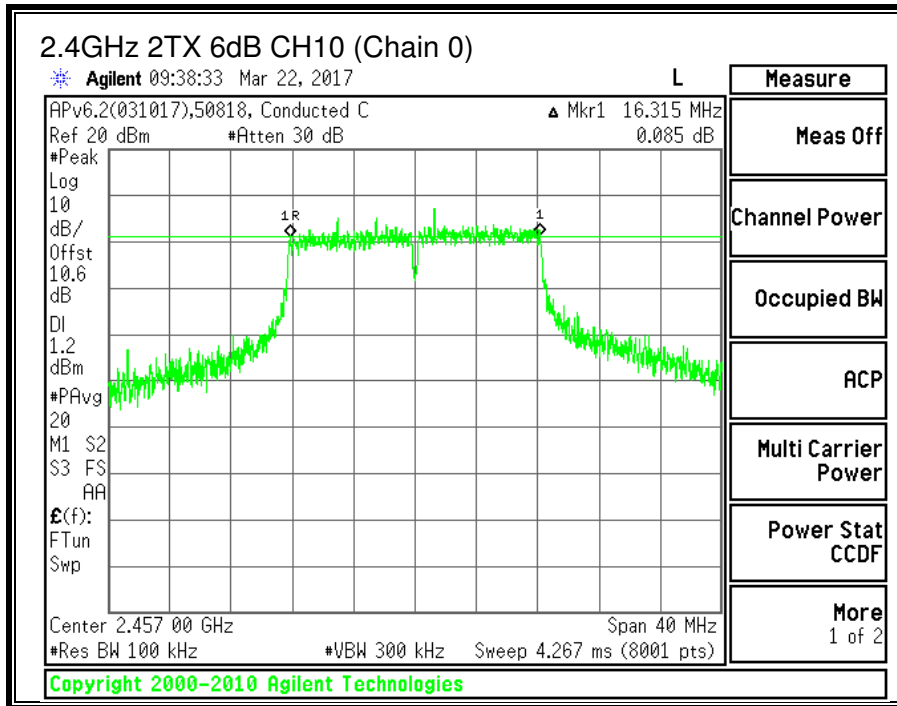

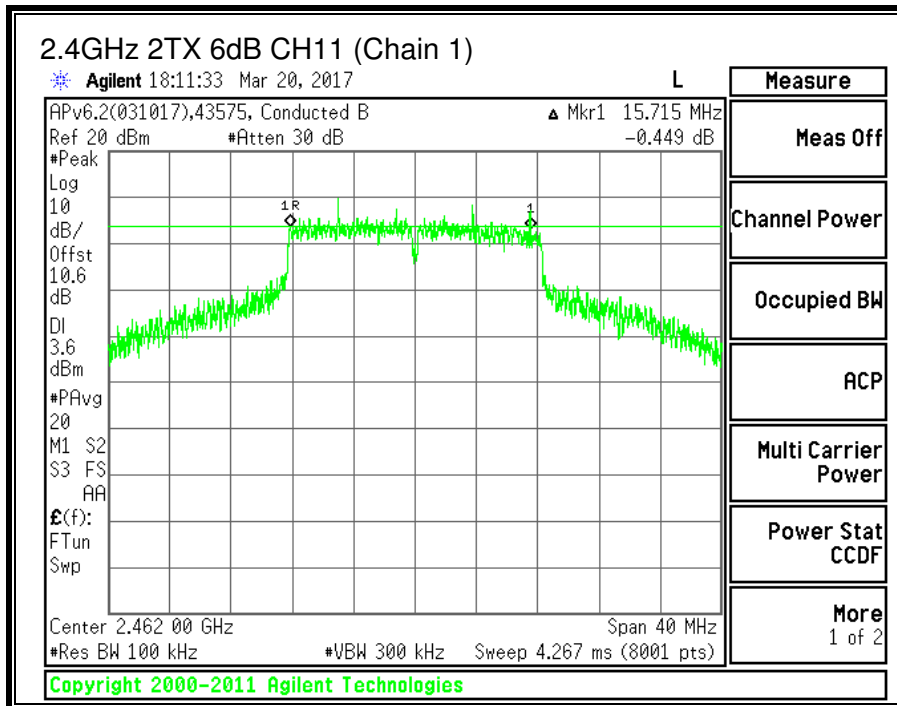
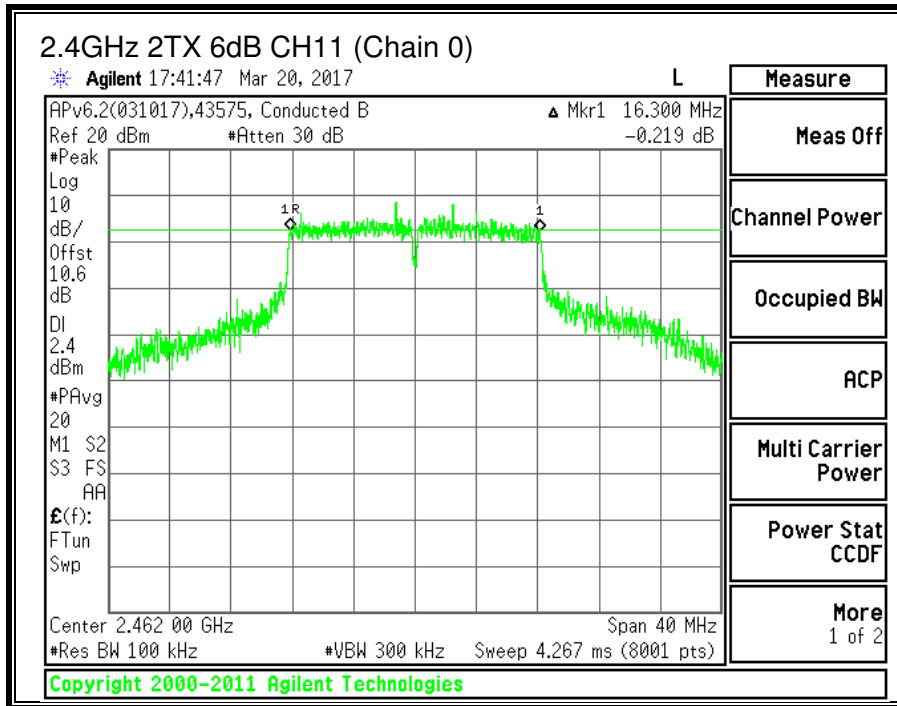

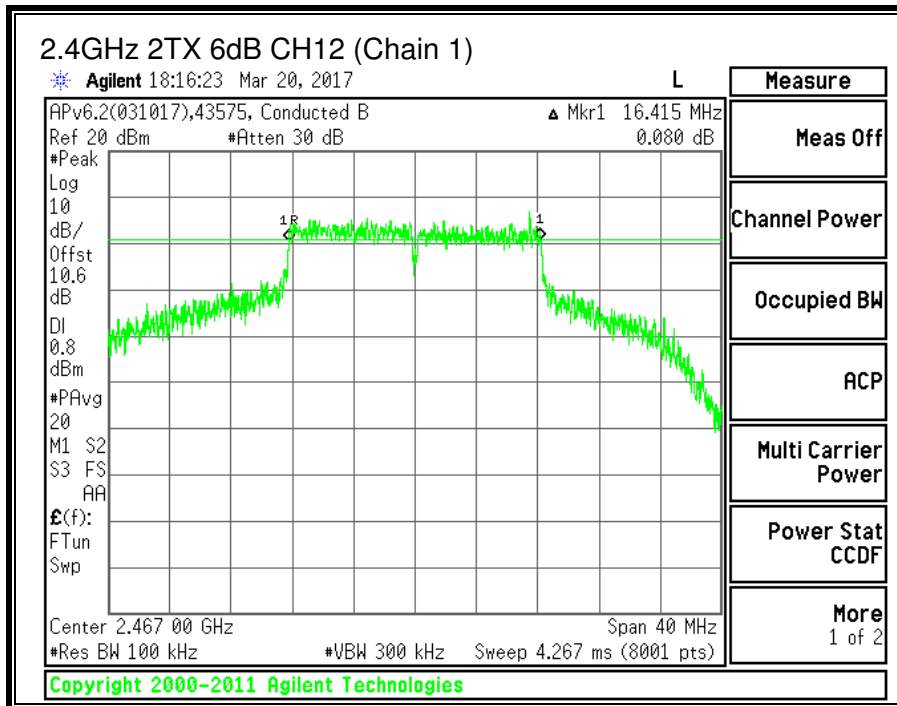
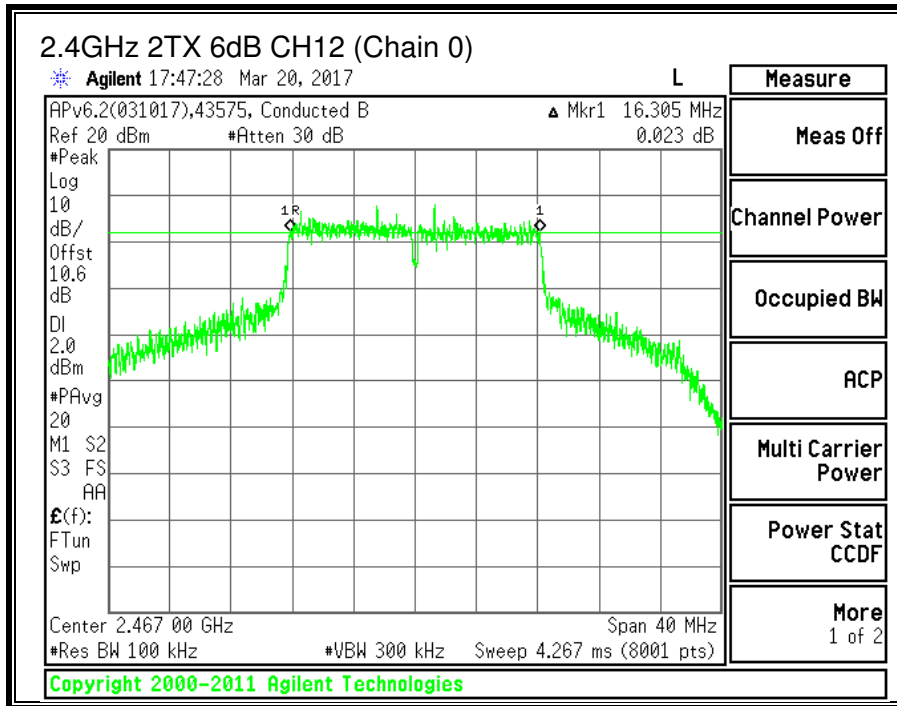

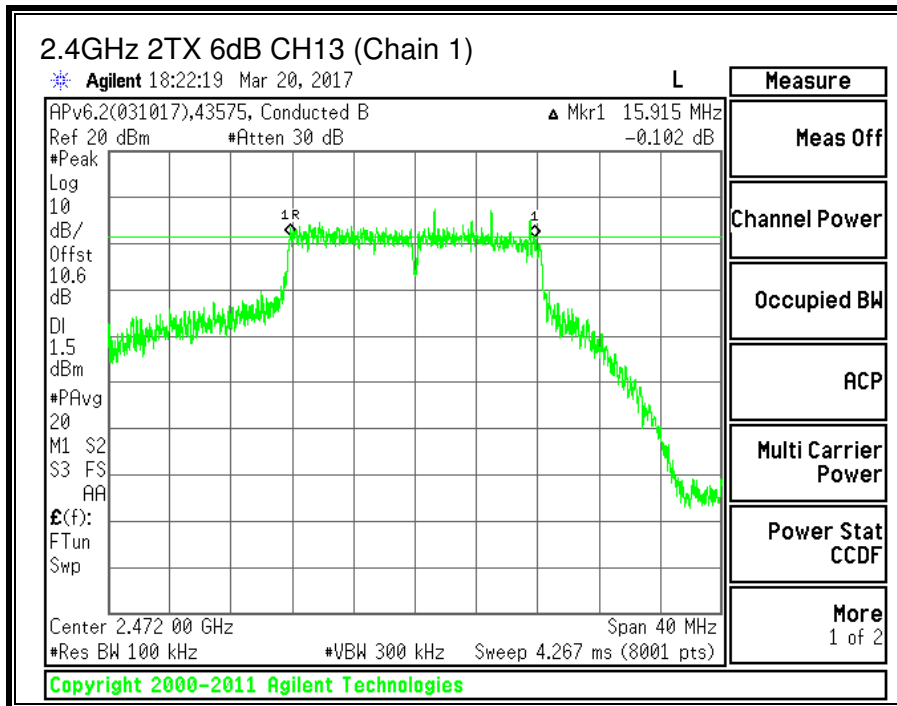
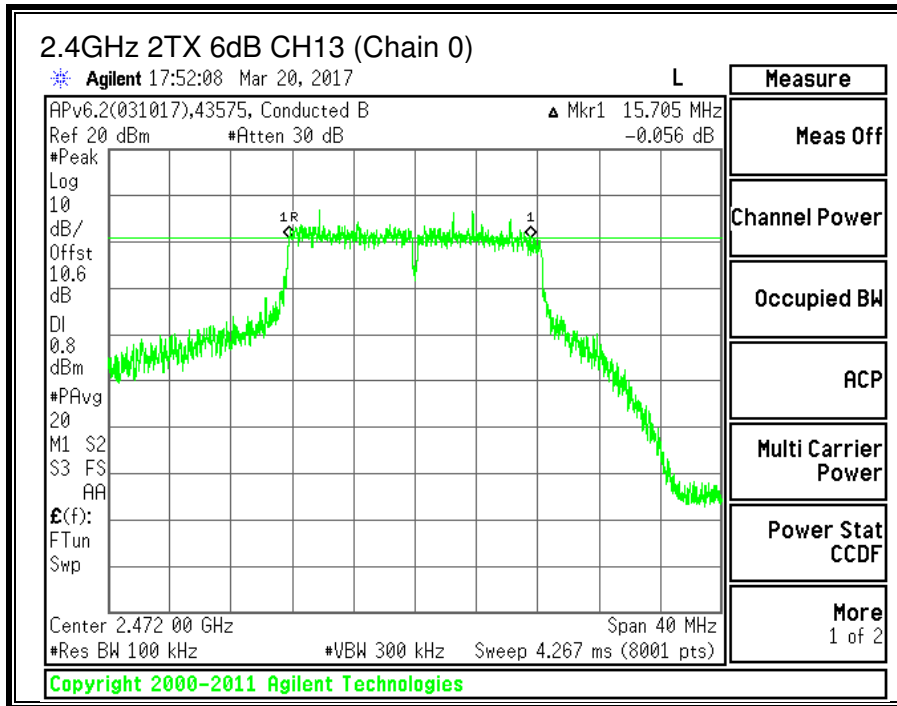

9.3.2. 99% BANDWIDTH

LIMITS

None; for reporting purposes only.

RESULTS

Channel	Frequency (MHz)	99% Bandwidth Chain 0 (MHz)	99% Bandwidth Chain 1 (MHz)
CH1	2412	16.5144	16.3012
CH2	2417	16.4326	16.3066
CH3	2422	16.4151	17.5847
CH6	2437	16.3618	18.6580
CH10	2457	16.3159	16.4034
CH11	2462	17.0272	16.4645
CH12	2467	16.7367	16.2267
CH13	2472	16.3556	16.2843

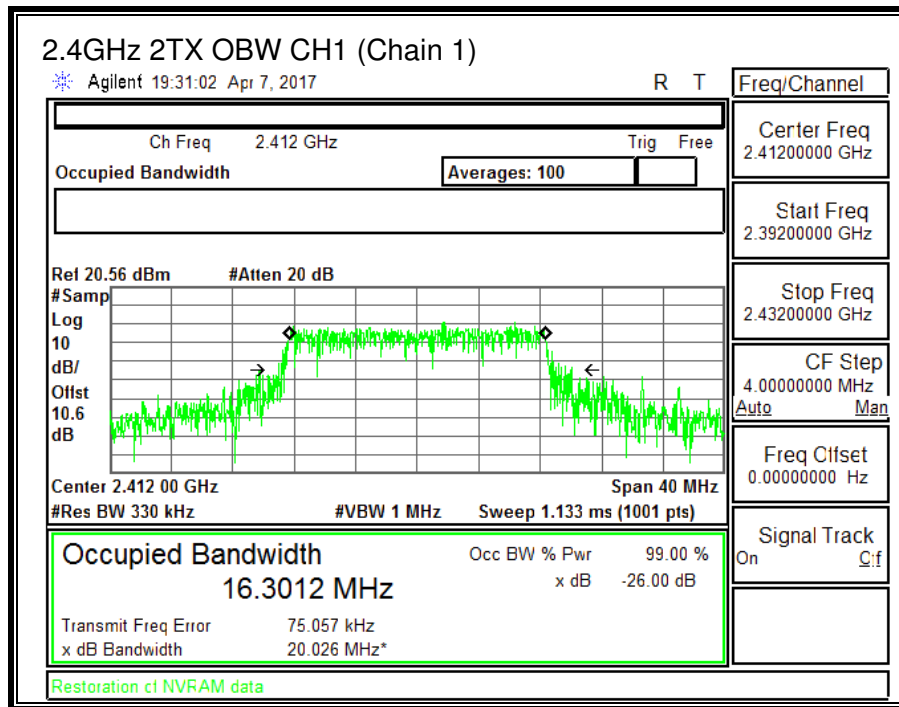
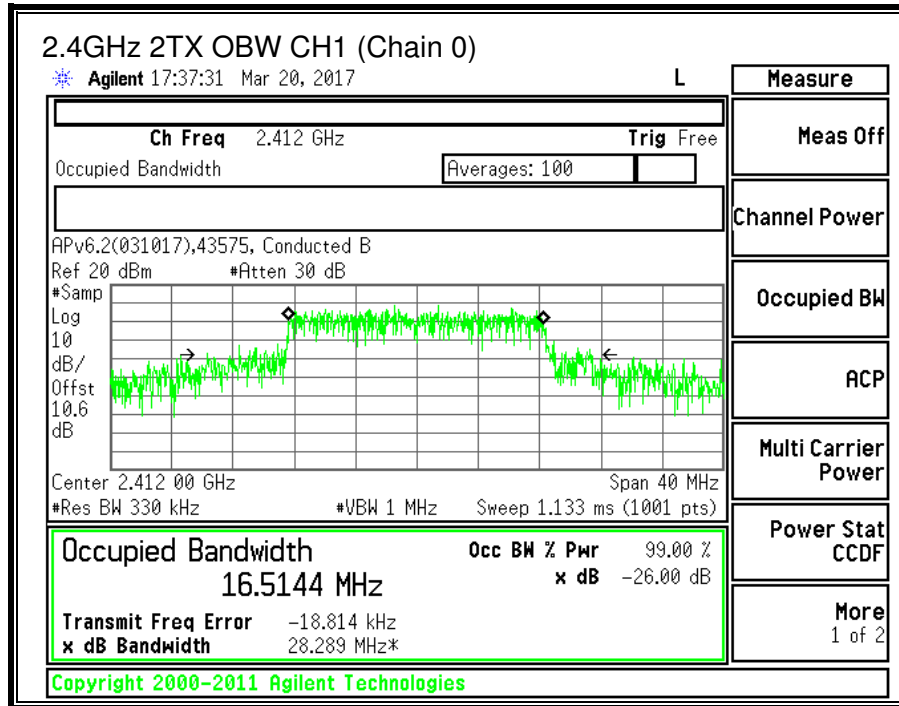

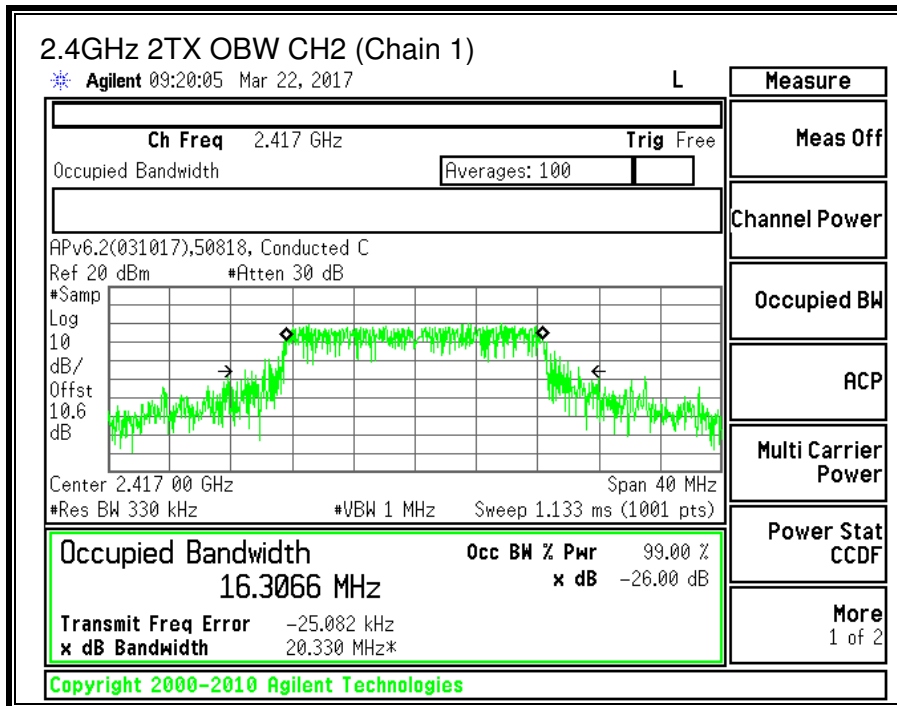
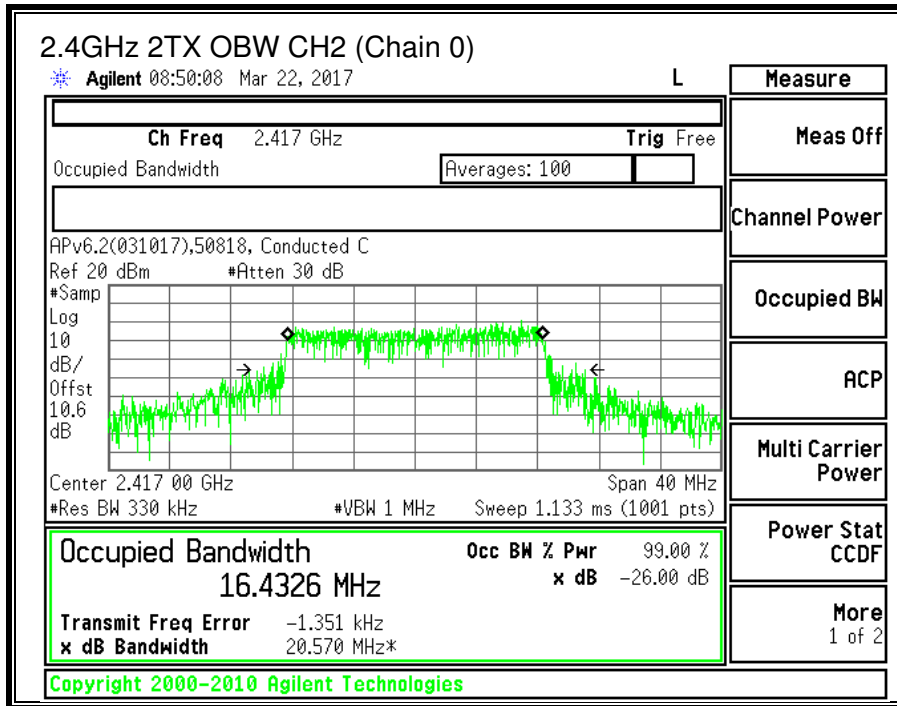

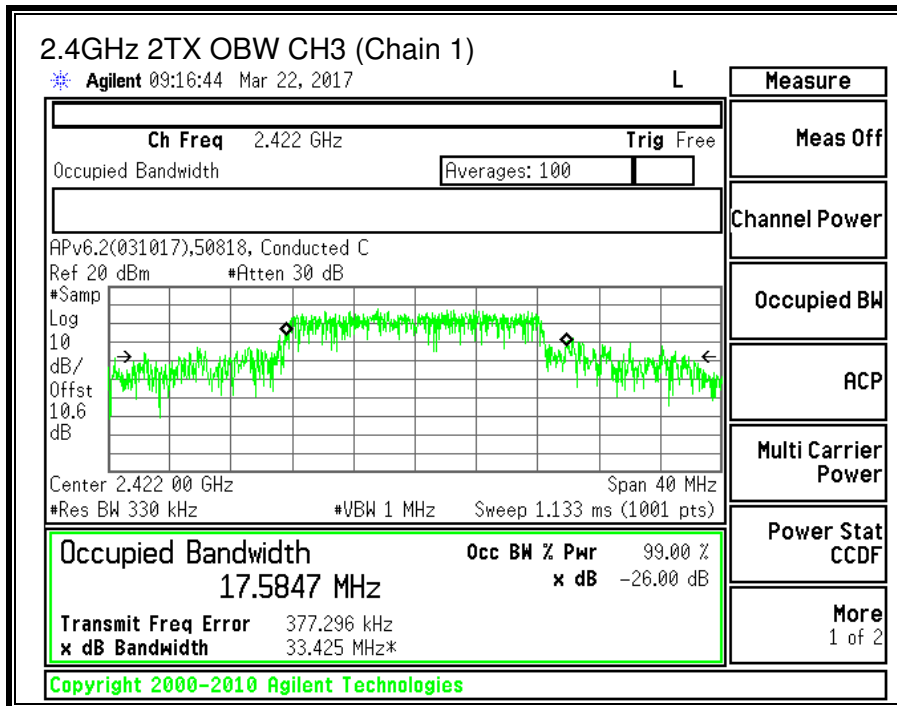
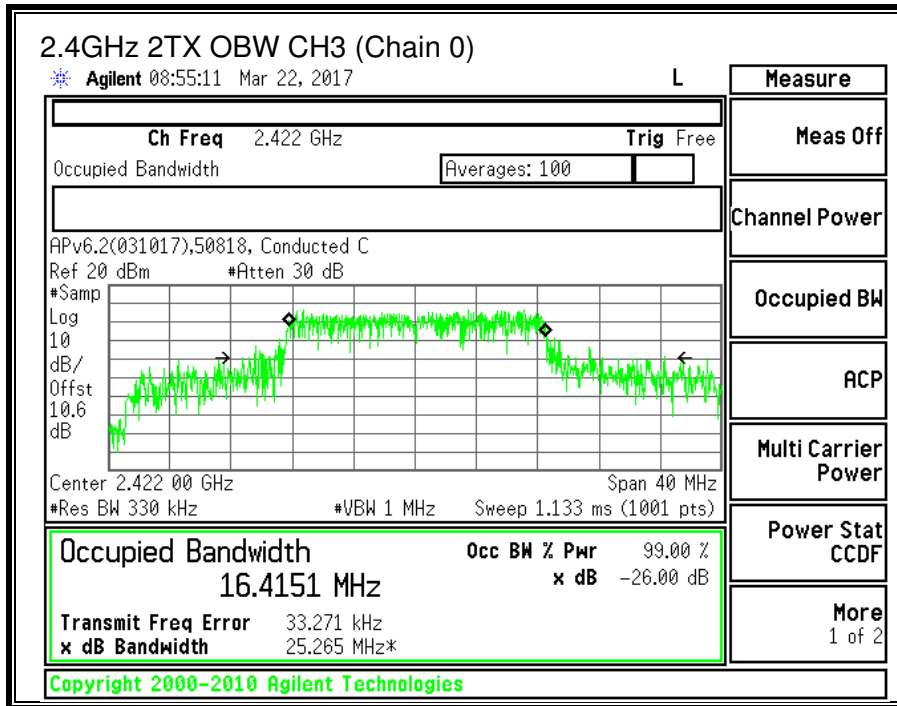

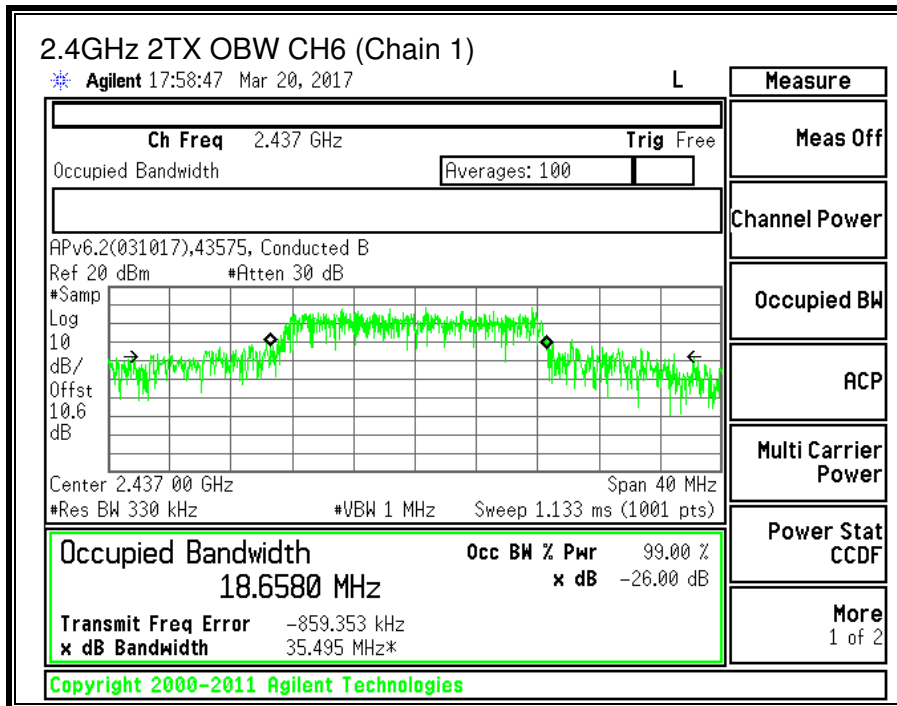
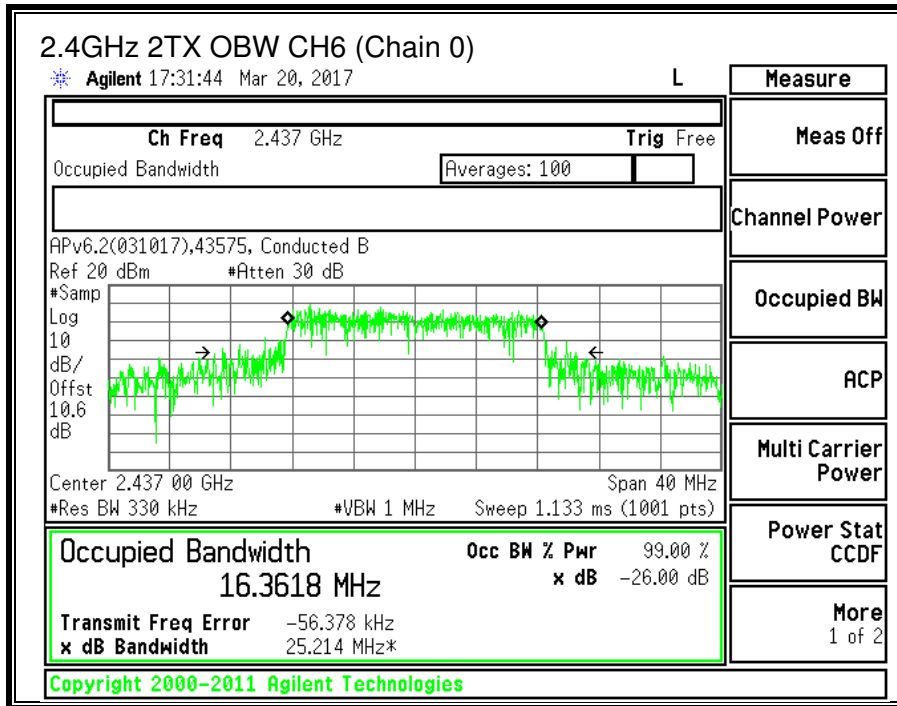

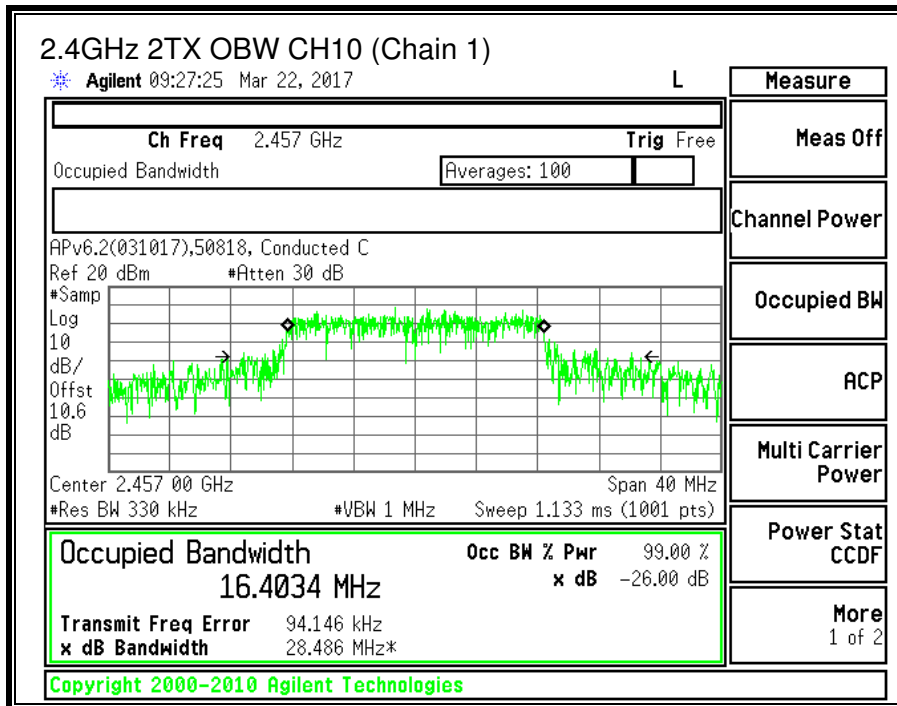
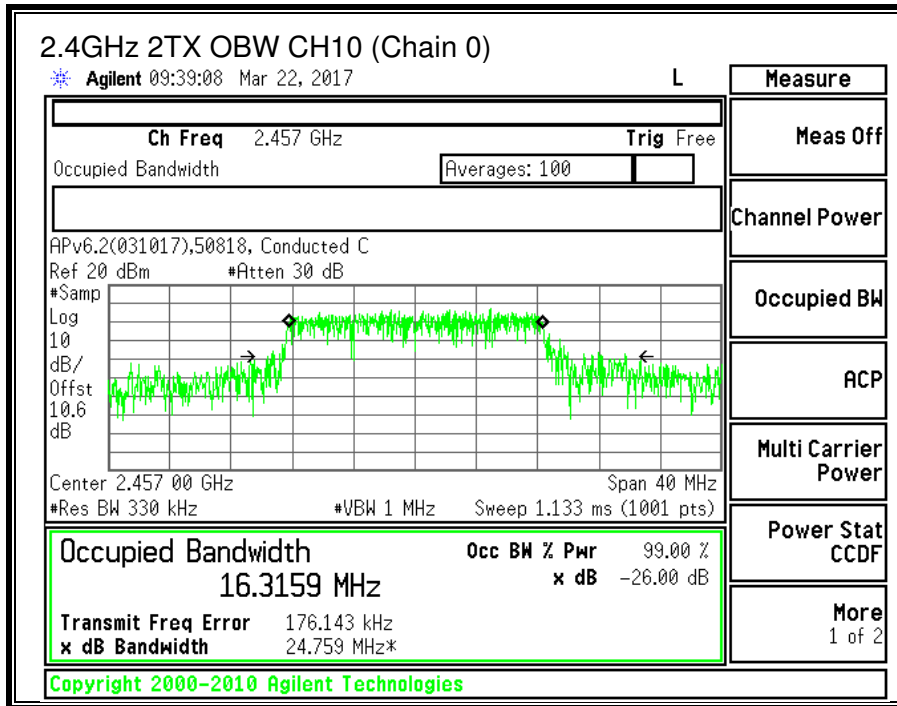

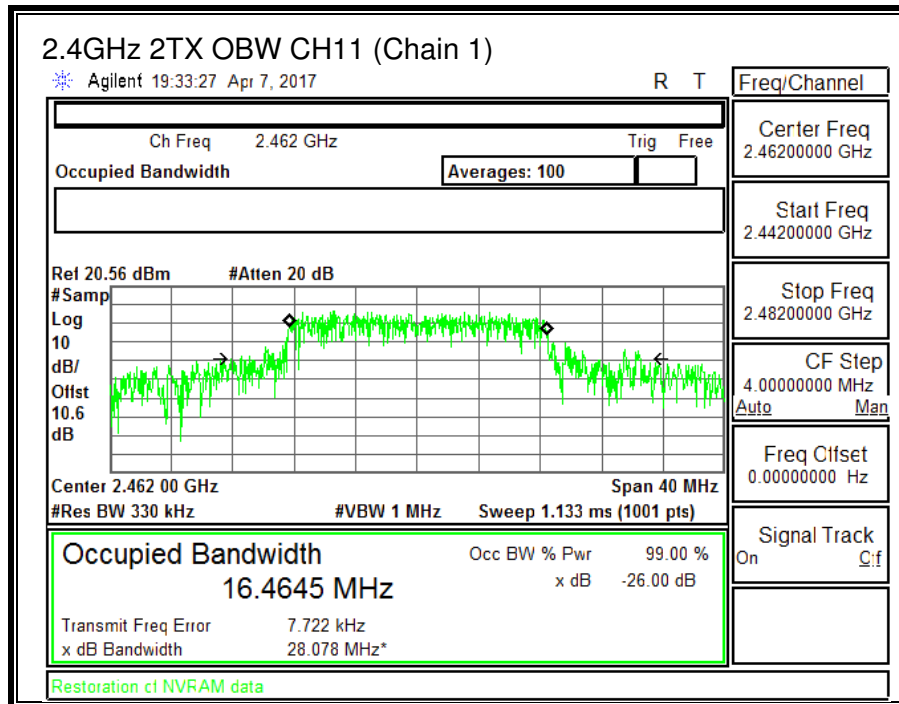
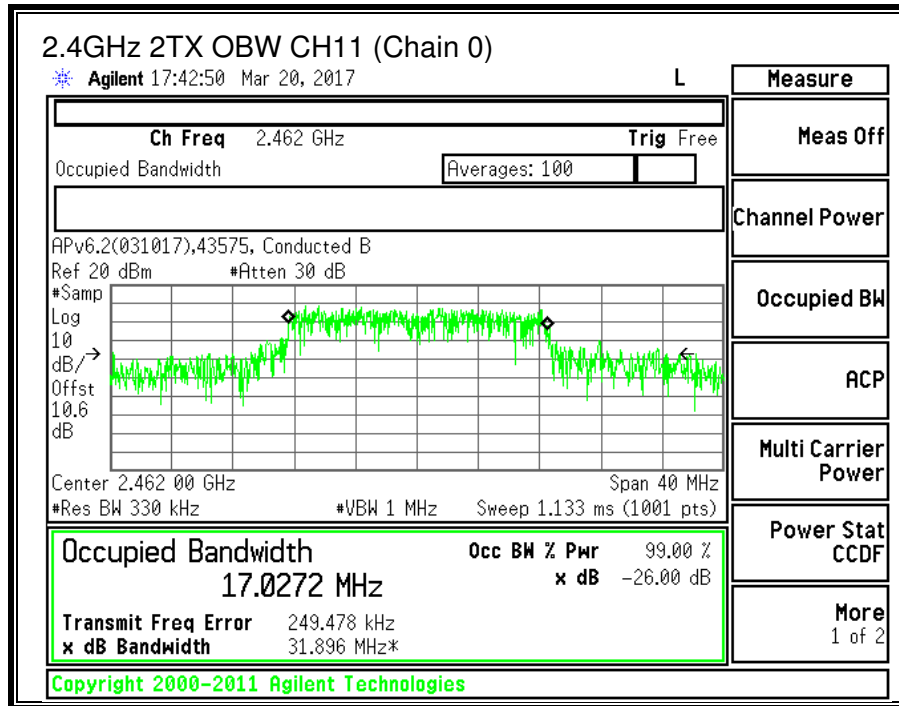

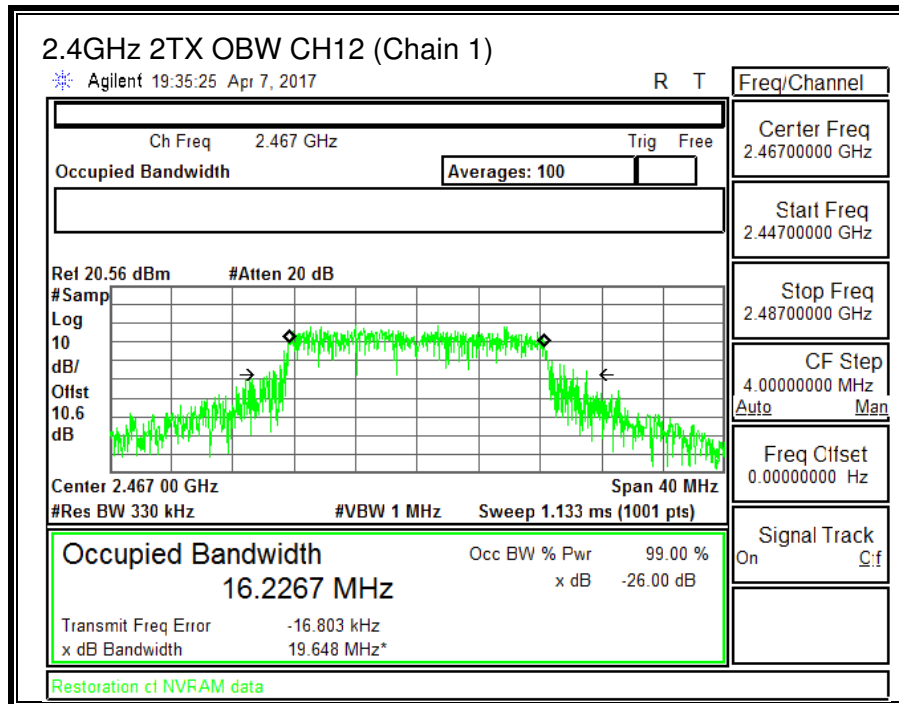
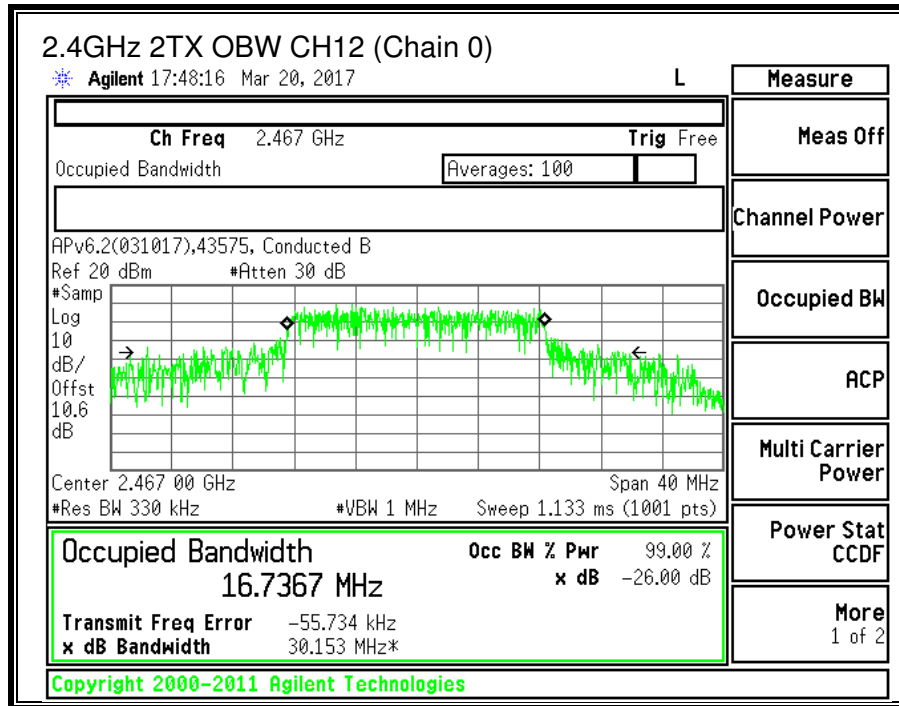

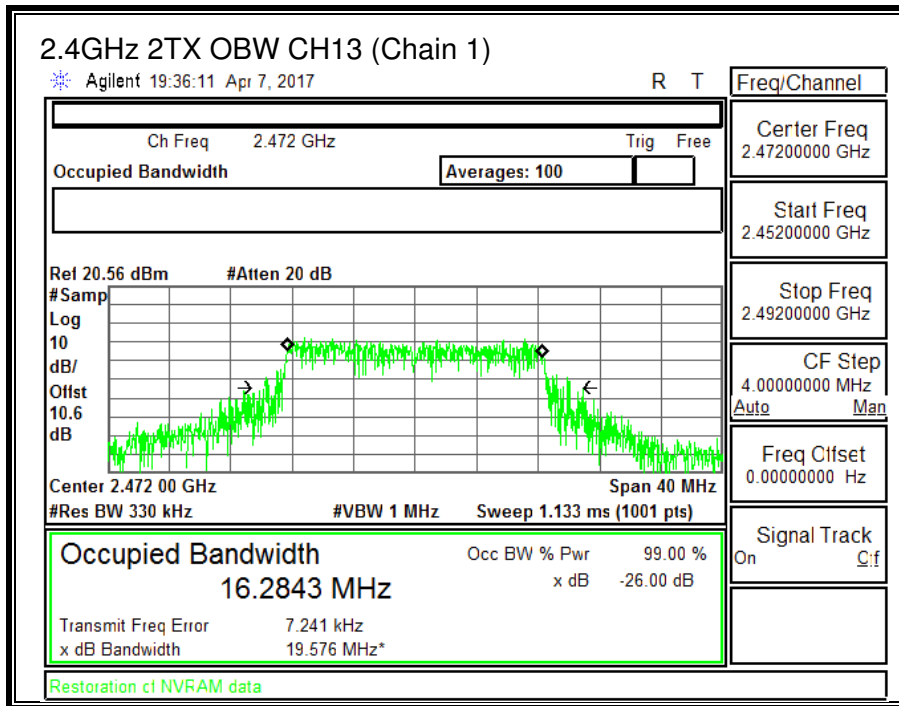
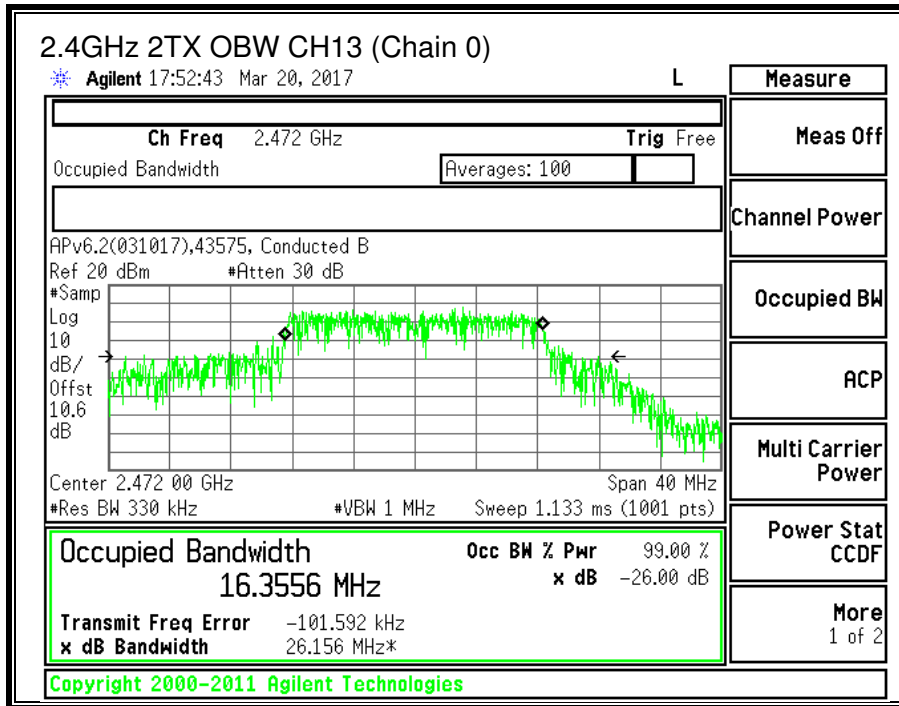

9.3.3. OUTPUT POWER

LIMITS

FCC §15.247 (b) (3)
IC RSS-247 (5.4) (4)

For systems using digital modulation in the 2400–2483.5 MHz, and 5725–5850 MHz bands: 1 Watt, based on the use of antennas with directional gains that do not exceed 6 dBi. If transmitting antennas of directional gain greater than 6 dBi are used, the conducted output power from the intentional radiator shall be reduced by the amount in dB that the directional gain of the antenna exceeds 6 dBi.

DIRECTIONAL ANTENNA GAIN

The TX chains are uncorrelated and the antenna gain is unequal among the chains. The directional gain is:

Chain 0 Antenna Gain (dBi)	Chain 1 Antenna Gain (dBi)	Uncorrelated Chains Directional Gain (dBi)
-5.20	-9.80	-6.92

TEST PROCEDURE

KDB 58074 D01 v03r05 Section 9.2.3.2

RESULTS

ID:	50818	Date:	03/23/2017
------------	-------	--------------	------------

Limits

Channel	Frequency (MHz)	Directional Gain (dBi)	FCC Power Limit (dBm)	IC Power Limit (dBm)	IC EIRP Limit (dBm)	Max Power (dBm)
CH1	2412	-6.92	30.00	30	36	30.00
CH2	2417	-6.92	30.00	30	36	30.00
CH3	2422	-6.92	30.00	30	36	30.00
CH6	2437	-6.92	30.00	30	36	30.00
CH10	2457	-6.92	30.00	30	36	30.00
CH11	2462	-6.92	30.00	30	36	30.00
CH12	2467	-6.92	30.00	30	36	30.00
CH13	2472	-6.92	30.00	30	36	30.00

Results

Channel	Frequency (MHz)	Chain 0 Meas Power (dBm)	Chain 1 Meas Power (dBm)	Total Corr'd Power (dBm)	Power Limit (dBm)	Margin (dB)
CH1	2412	9.87	11.95	14.04	30.00	-15.96
CH2	2417	9.63	11.89	13.92	30.00	-16.08
CH3	2422	17.86	19.11	21.54	30.00	-8.46
CH6	2437	17.96	18.26	21.12	30.00	-8.88
CH10	2457	18.08	17.79	20.95	30.00	-9.05
CH11	2462	15.04	14.74	17.90	30.00	-12.10
CH12	2467	9.74	9.76	12.76	30.00	-17.24
CH13	2472	3.44	3.74	6.60	30.00	-23.40

9.3.4. POWER SPECTRAL DENSITY

LIMITS

FCC §15.247 (e)
 IC RSS-247 (5.2) (2)

For digitally modulated systems, the power spectral density conducted from the intentional radiator to the antenna shall not be greater than 8 dBm in any 3 KHz band during any time interval of continuous transmissions.

RESULTS

Duty Cycle CF (dB)	0.27	Included in Calculations of Corr'd PSD
--------------------	------	--

PSD Results

Channel	Frequency (MHz)	Chain 0 Meas (dBm)	Chain 1 Meas (dBm)	Total Corr'd PSD (dBm)	Limit (dBm)	Margin (dB)
CH1	2412	-14.732	-12.508	-10.20	8.0	-18.2
CH2	2417	-14.383	-12.679	-10.17	8.0	-18.2
CH3	2422	-6.285	-6.163	-2.94	8.0	-10.9
CH6	2437	-6.142	-5.945	-2.76	8.0	-10.8
CH10	2457	-7.040	-7.318	-3.90	8.0	-11.9
CH11	2462	-6.301	-6.351	-3.05	8.0	-11.0
CH12	2467	-14.865	-14.533	-11.42	8.0	-19.4
CH13	2472	-20.867	-20.612	-17.46	8.0	-25.5

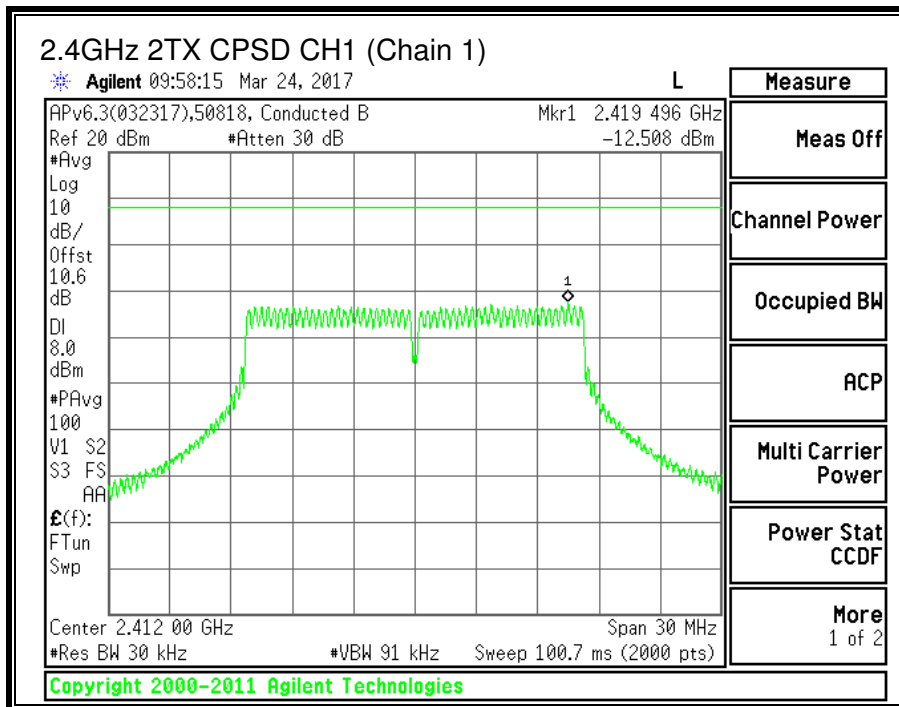
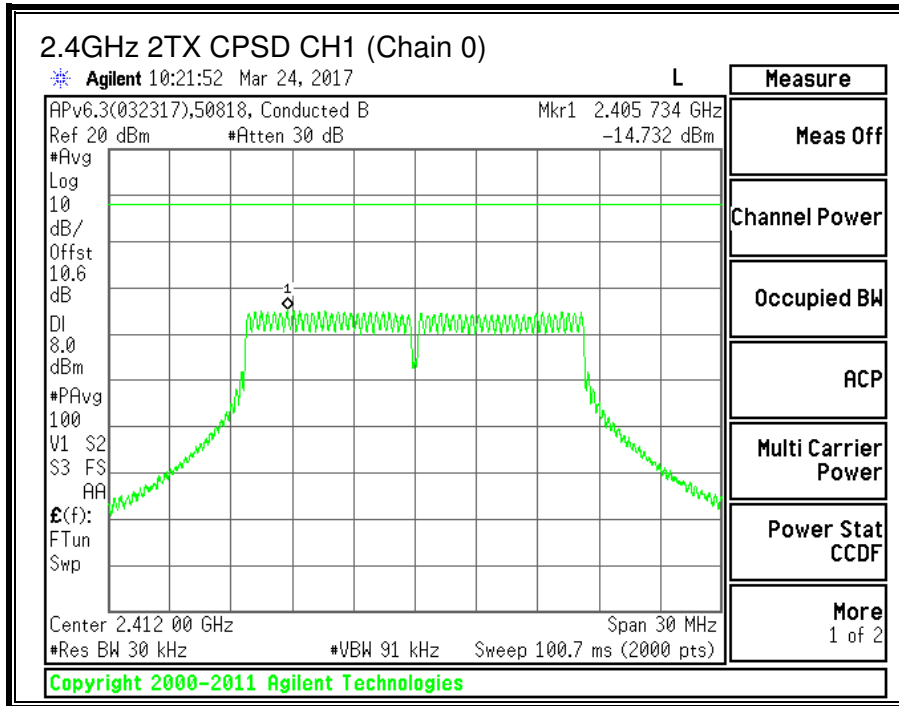

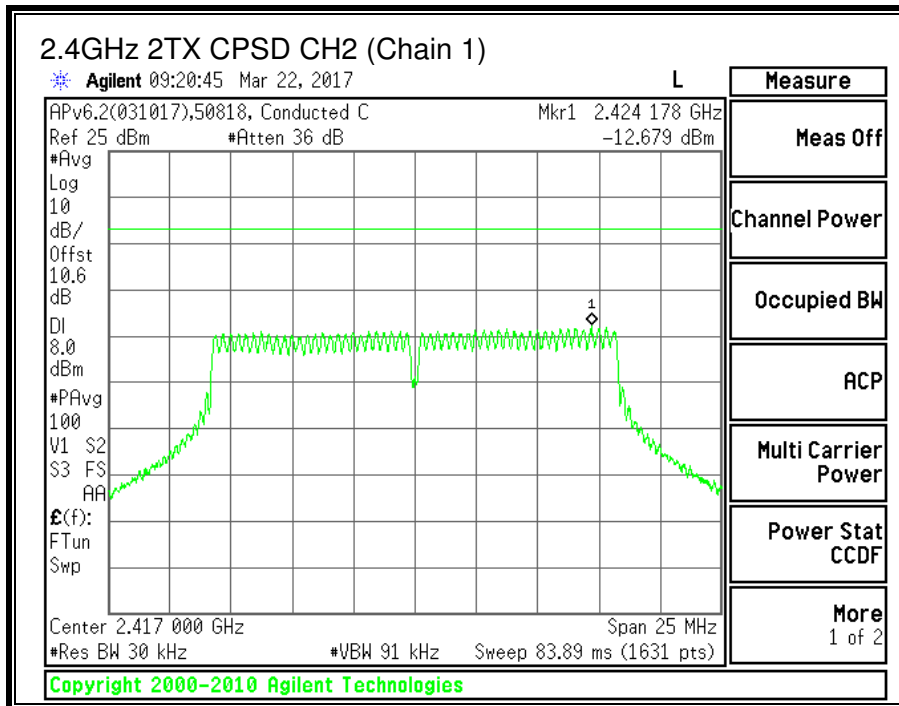
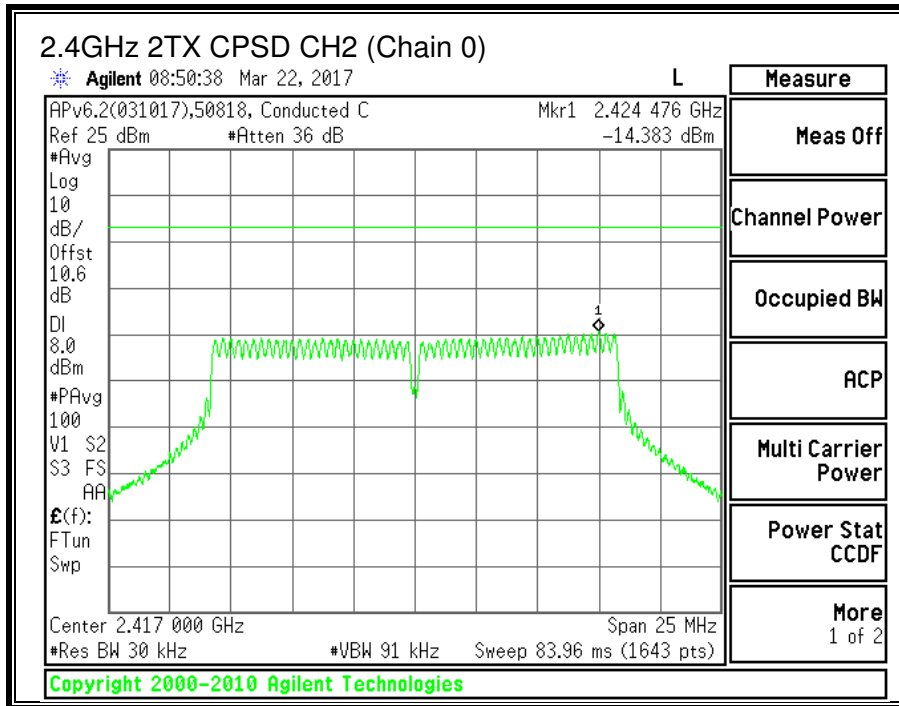

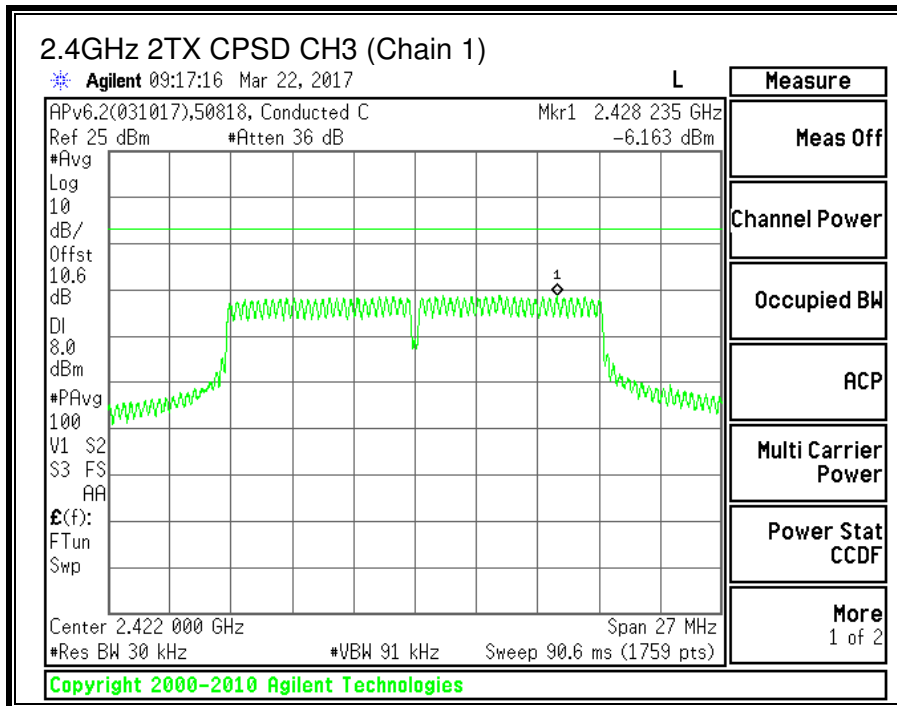
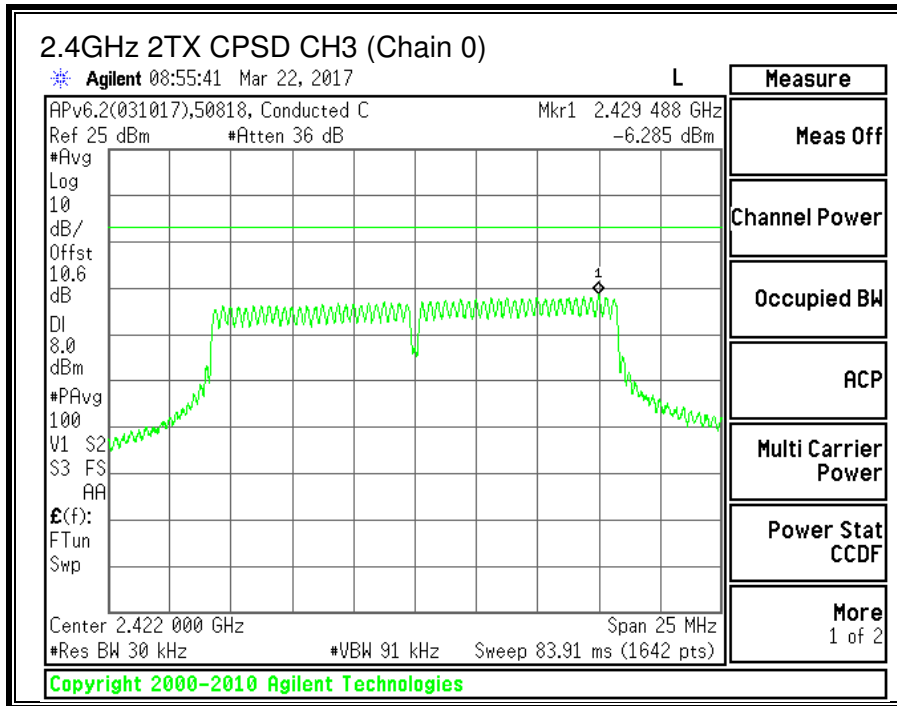

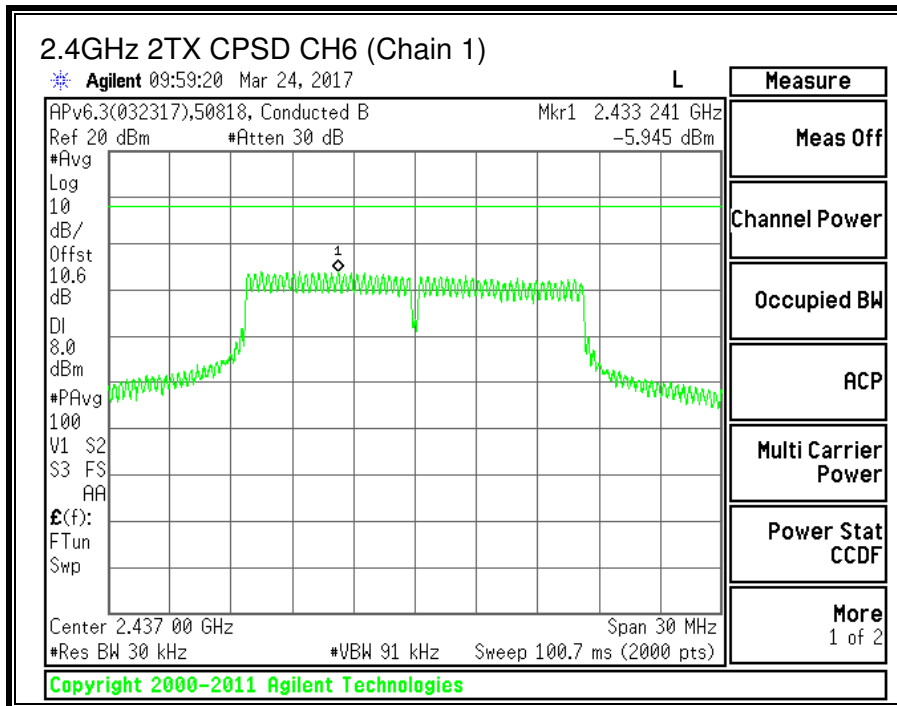
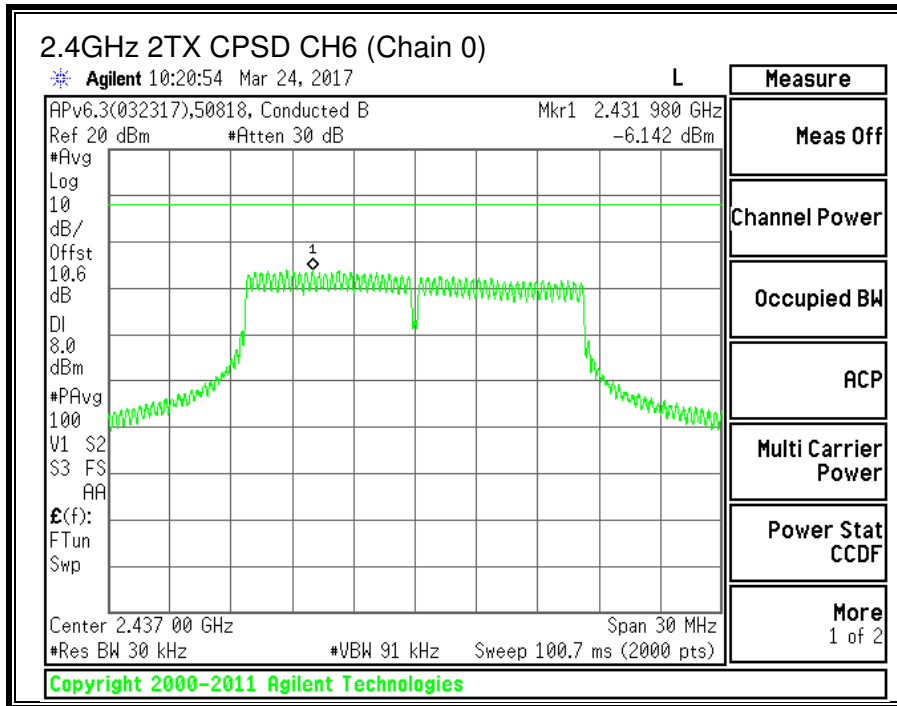

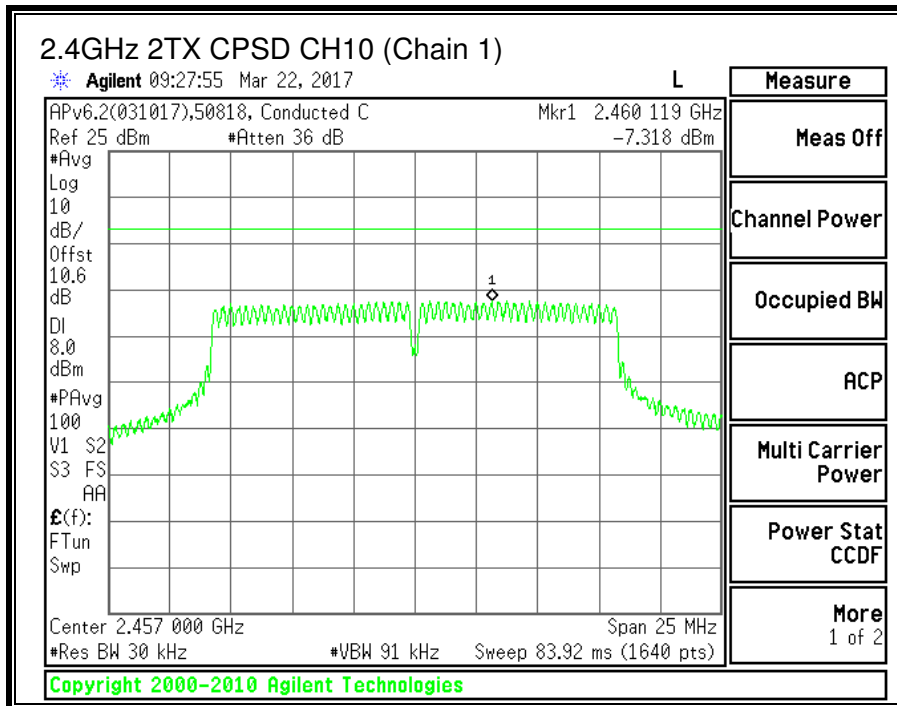
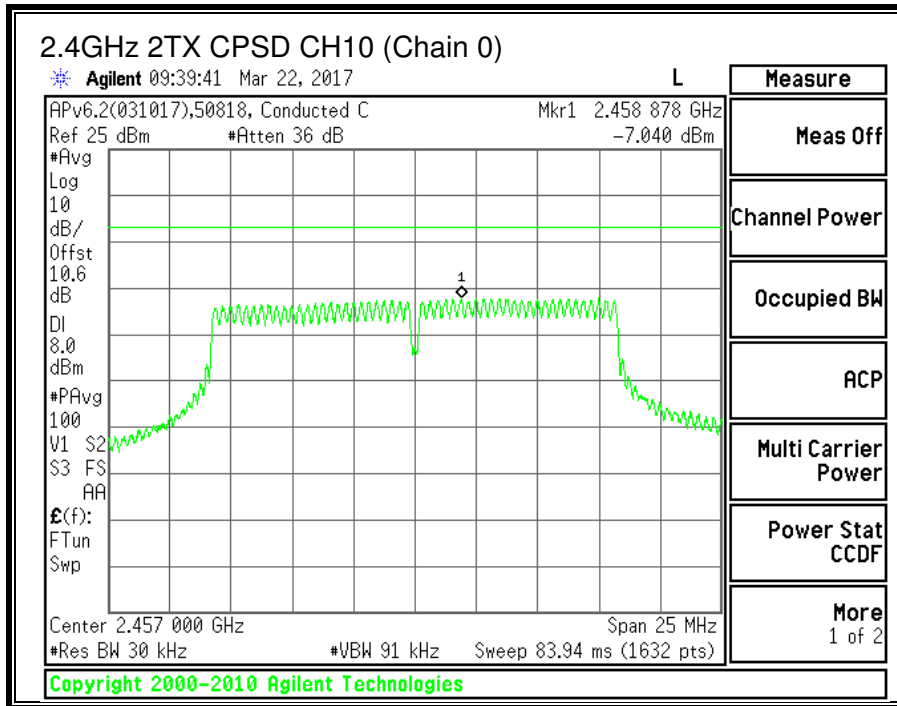

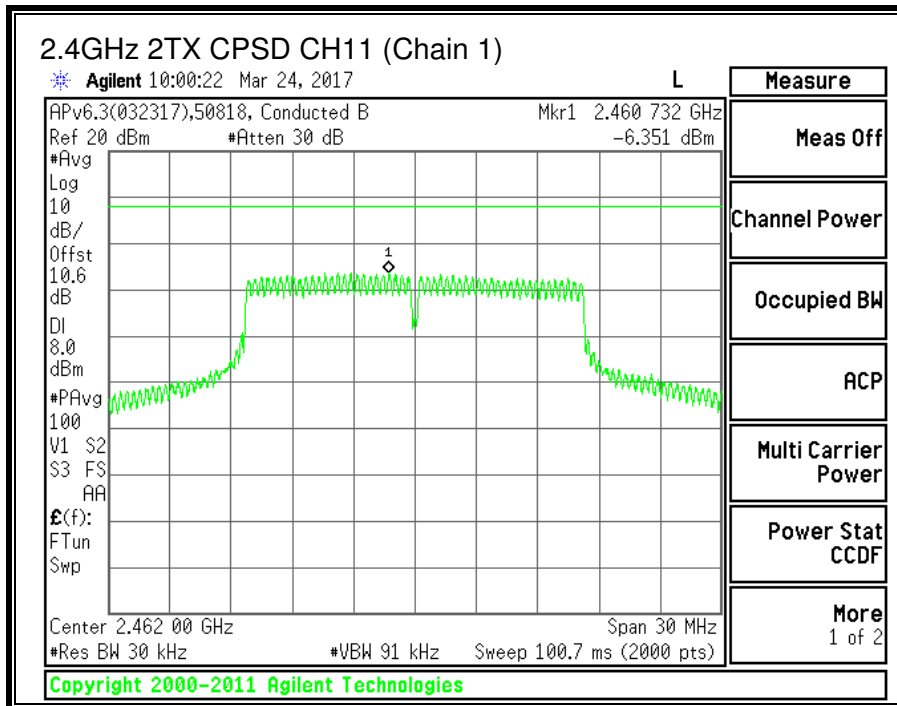
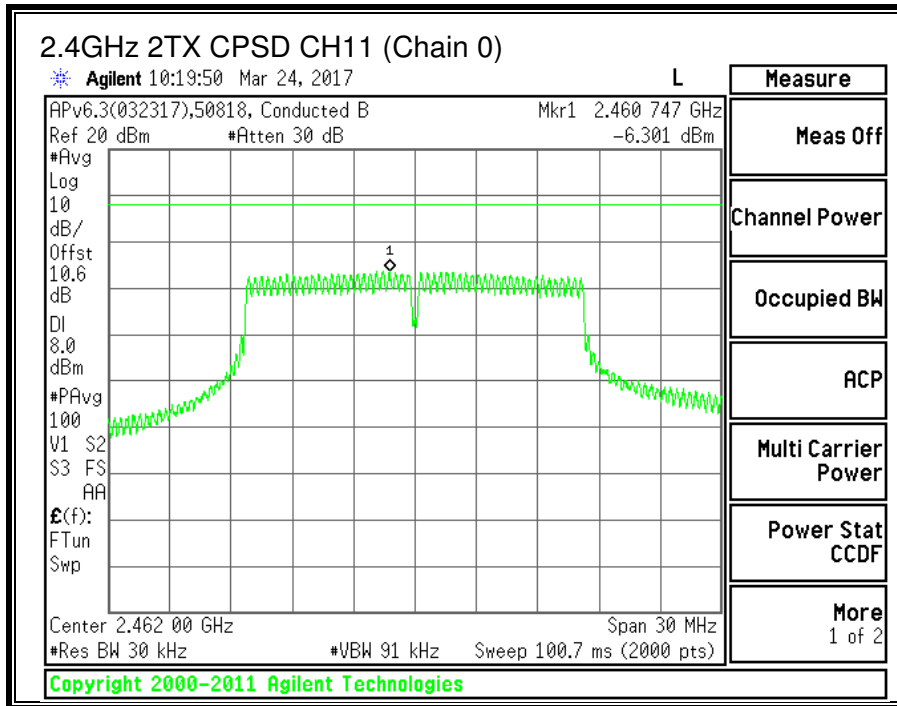

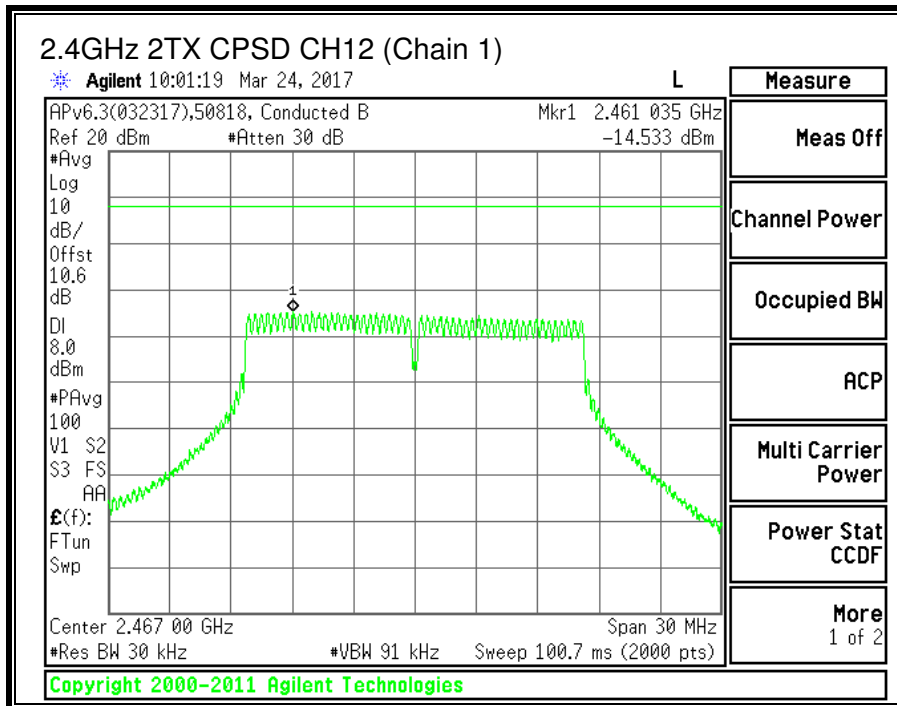
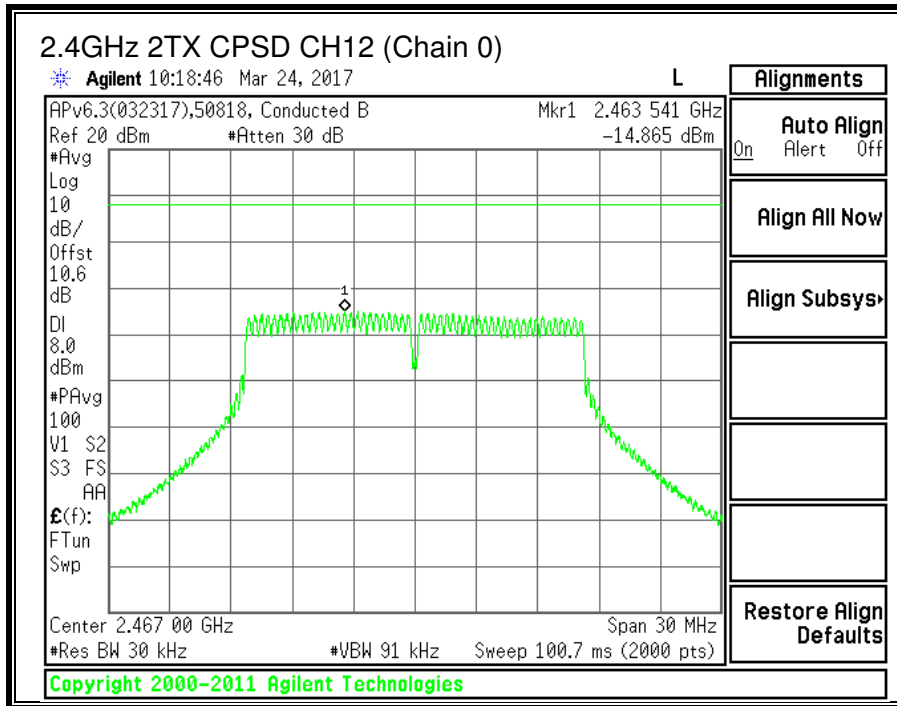

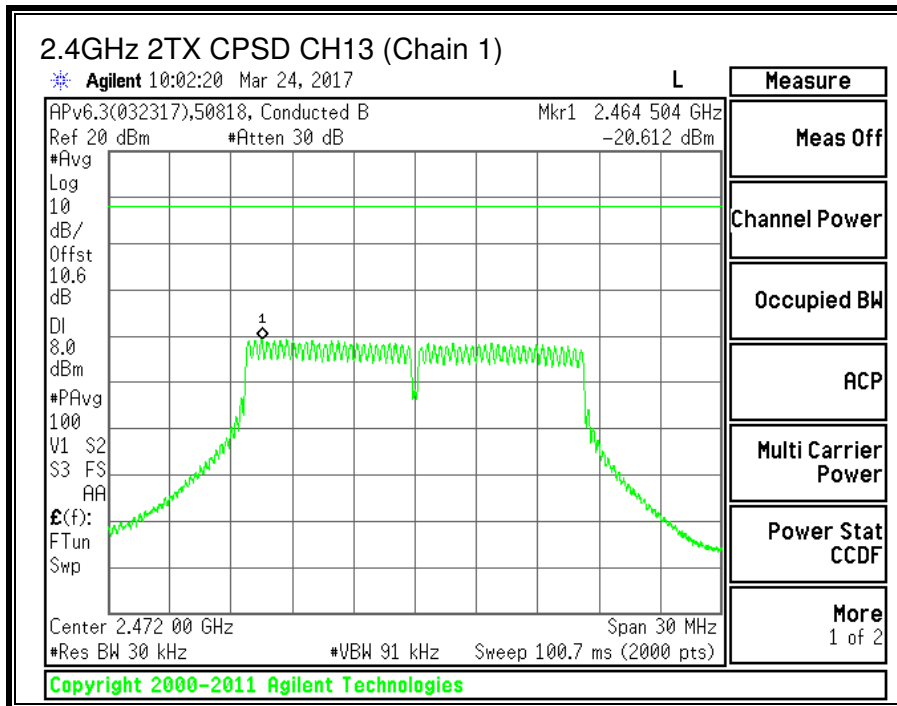
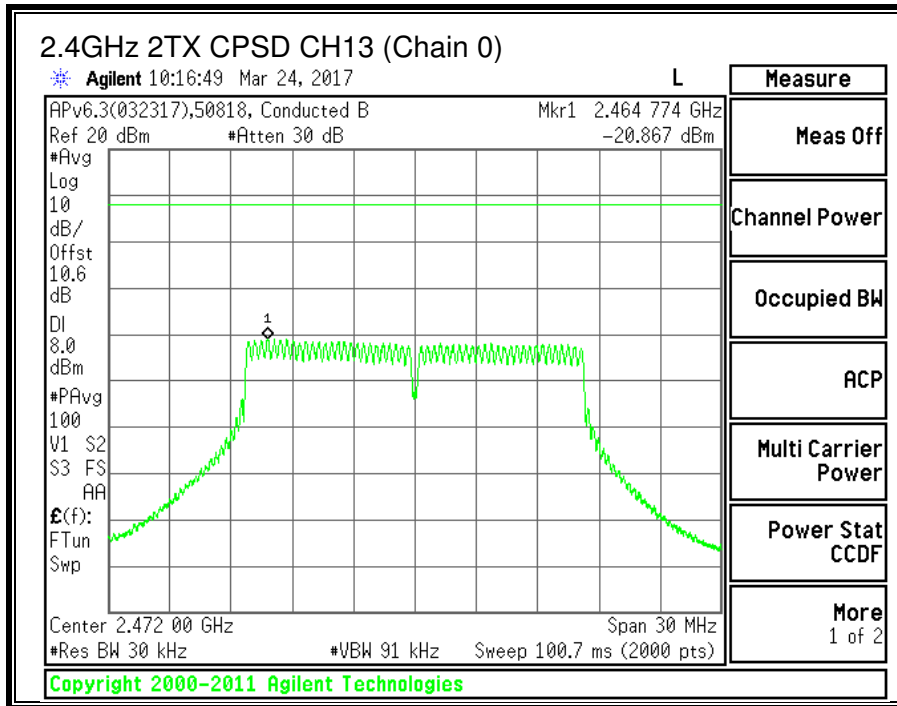

9.3.5. CONDUCTED BANDEDGE AND SPURIOUS EMISSIONS

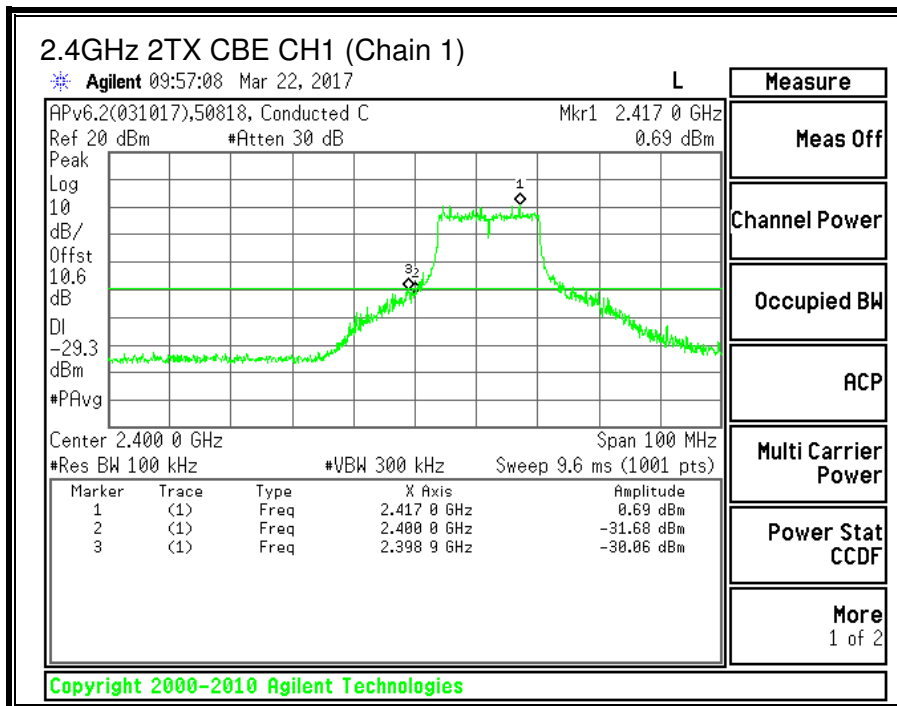
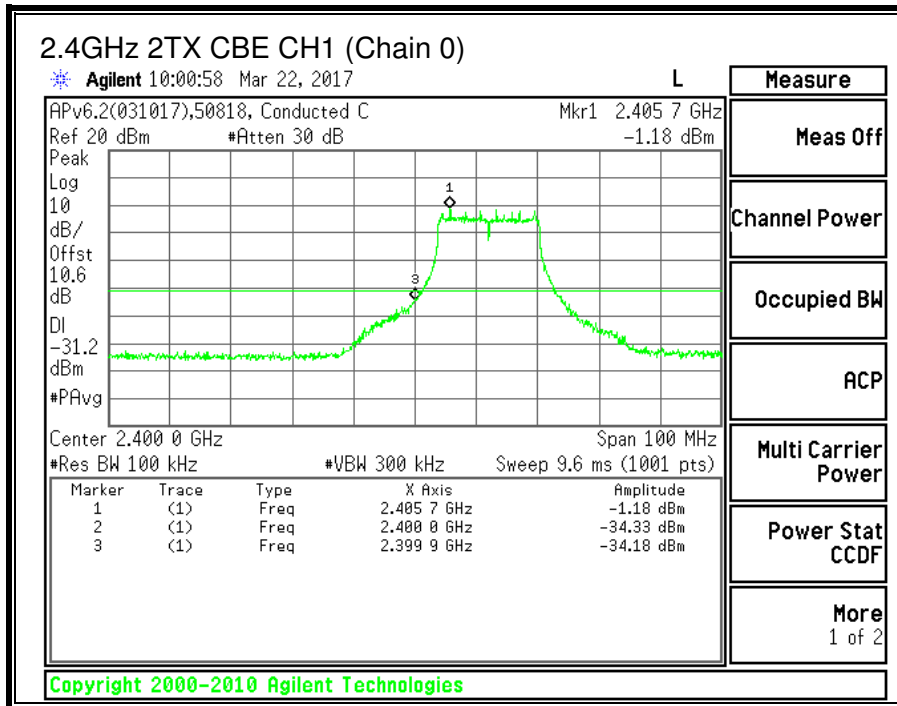

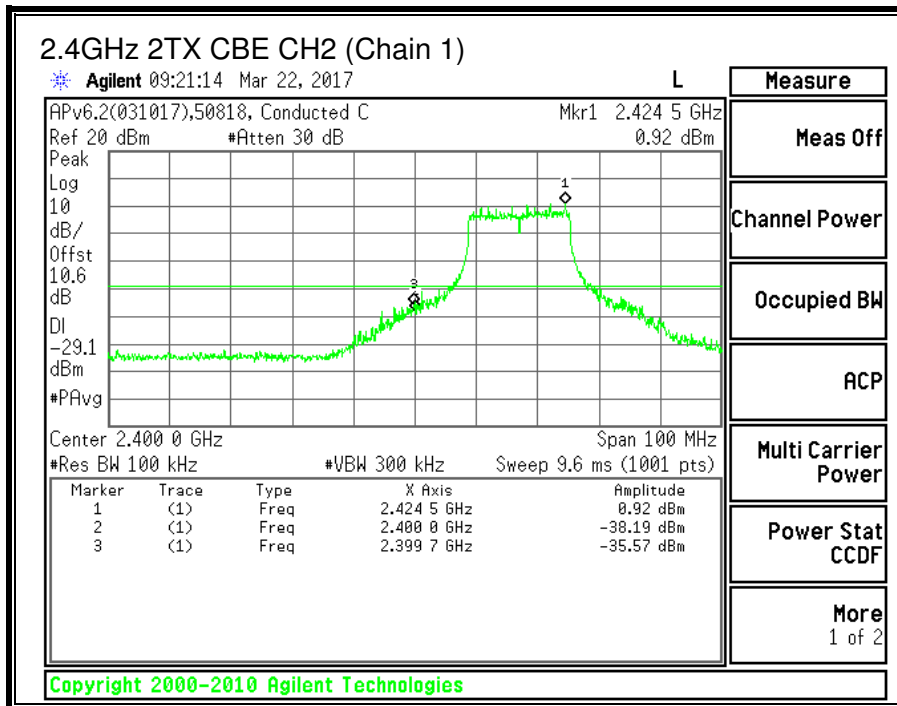
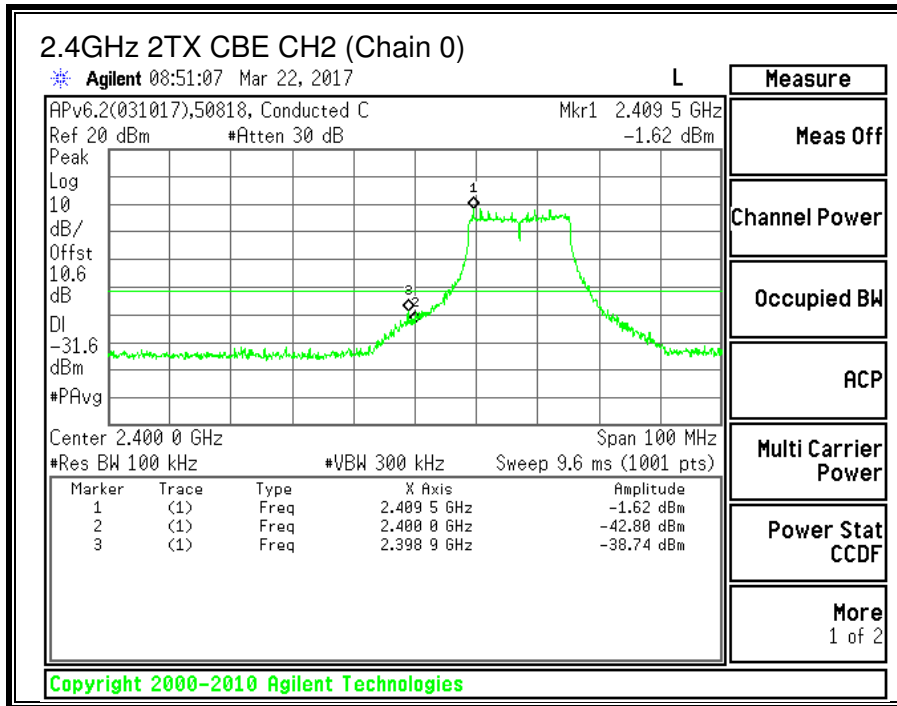

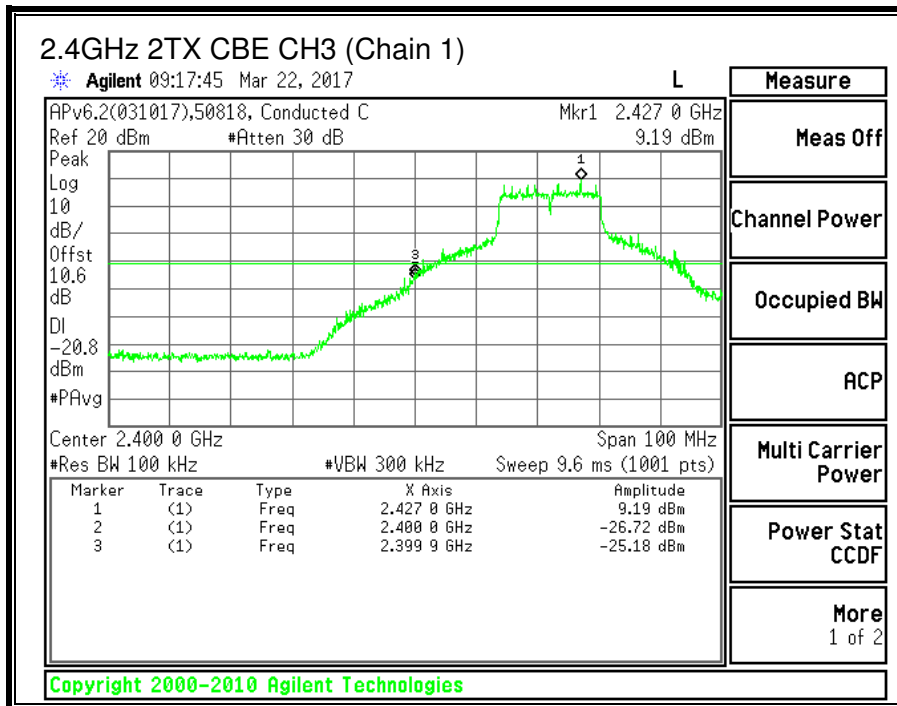
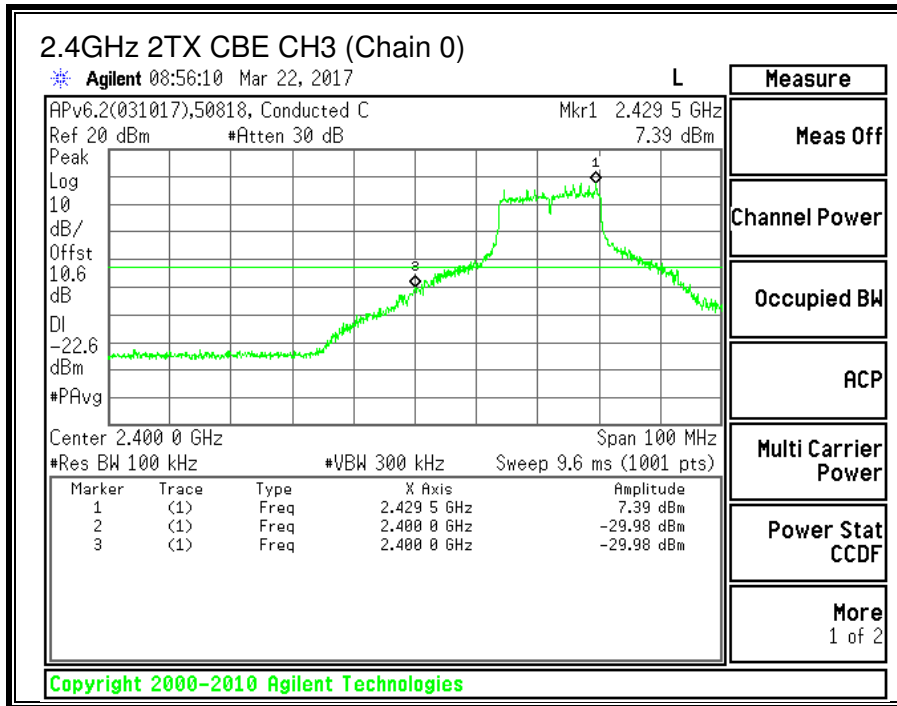

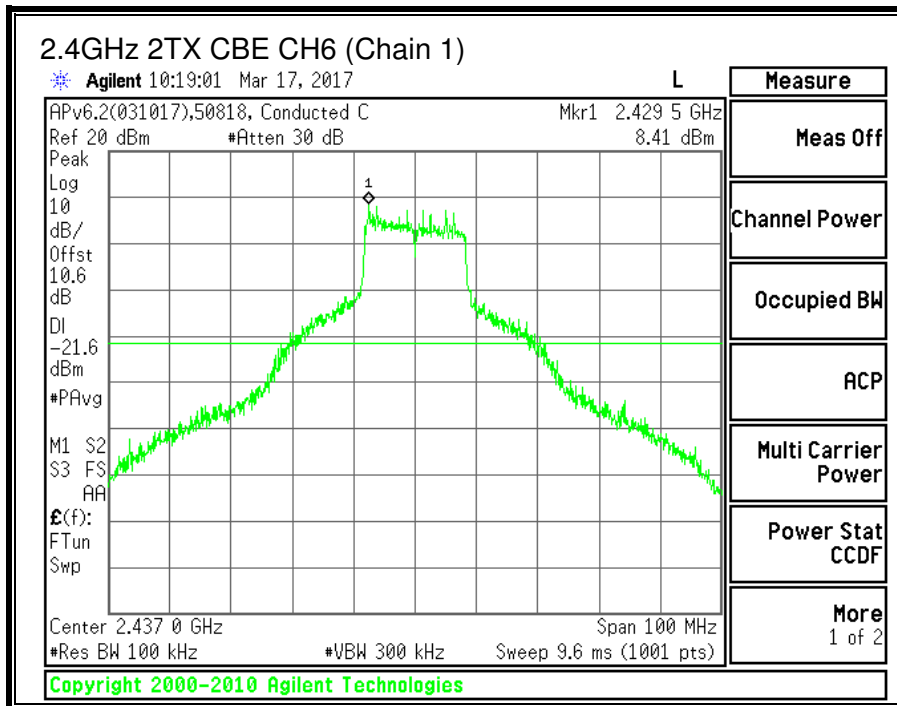
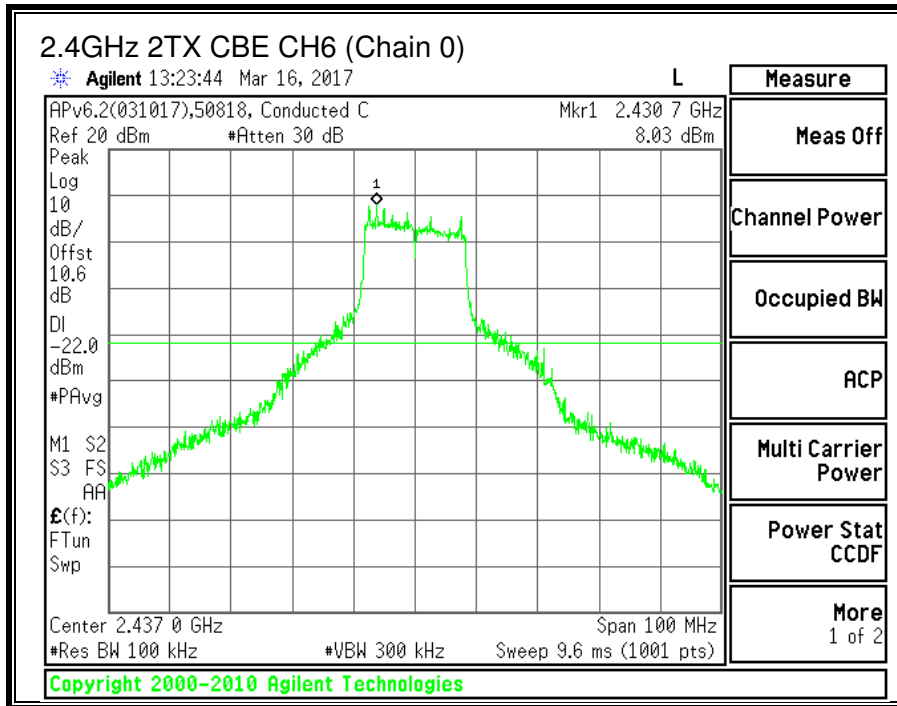

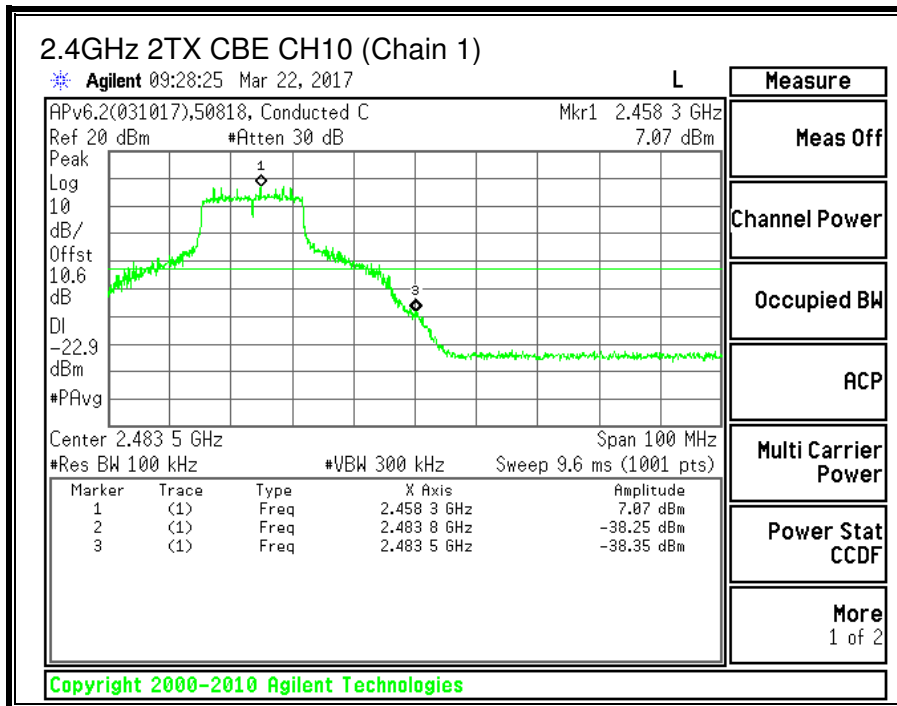
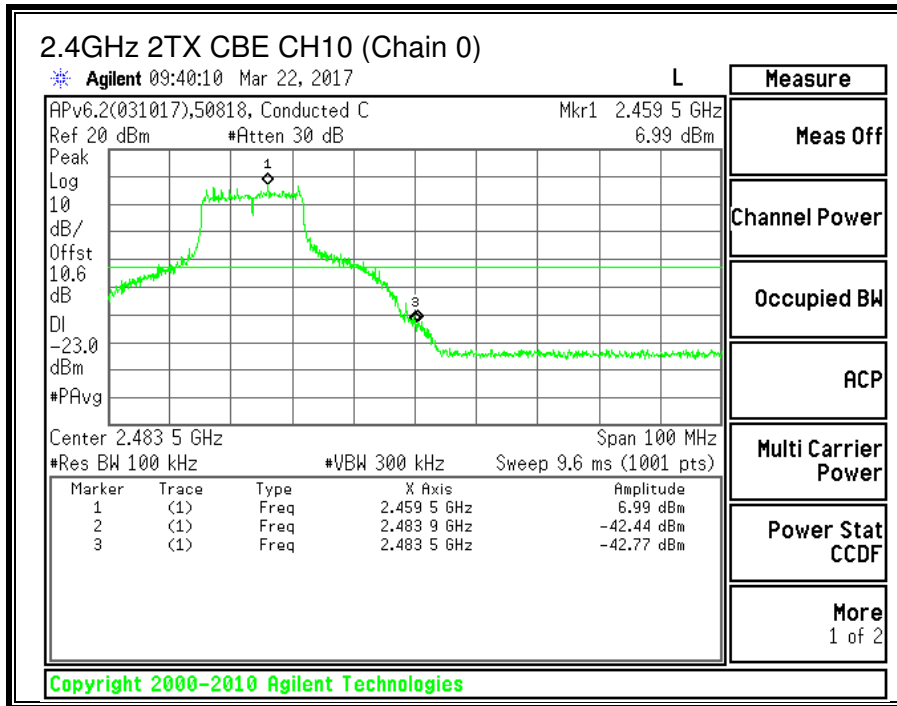

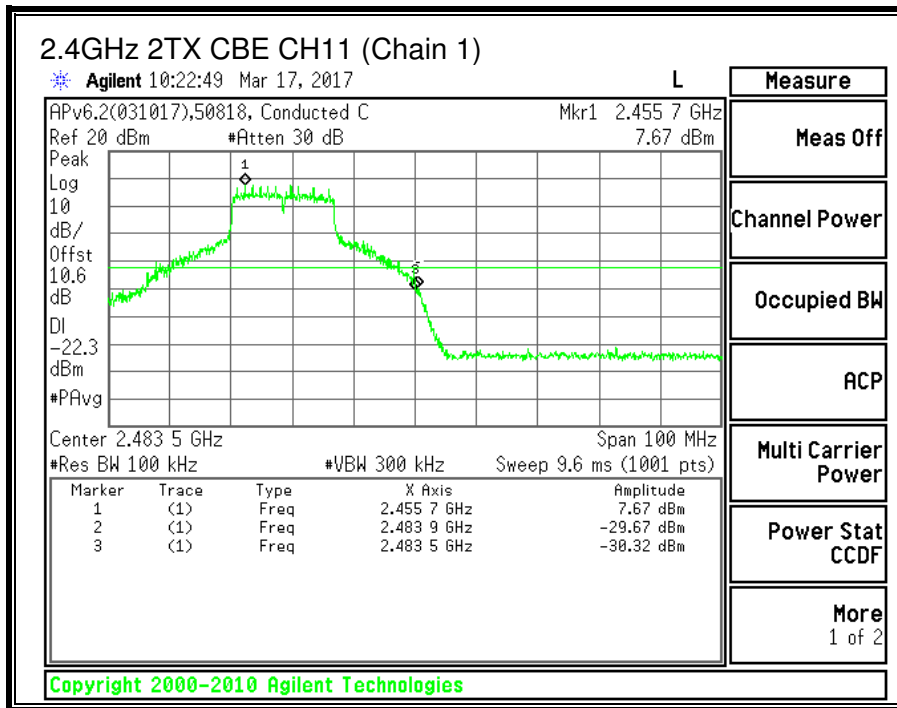
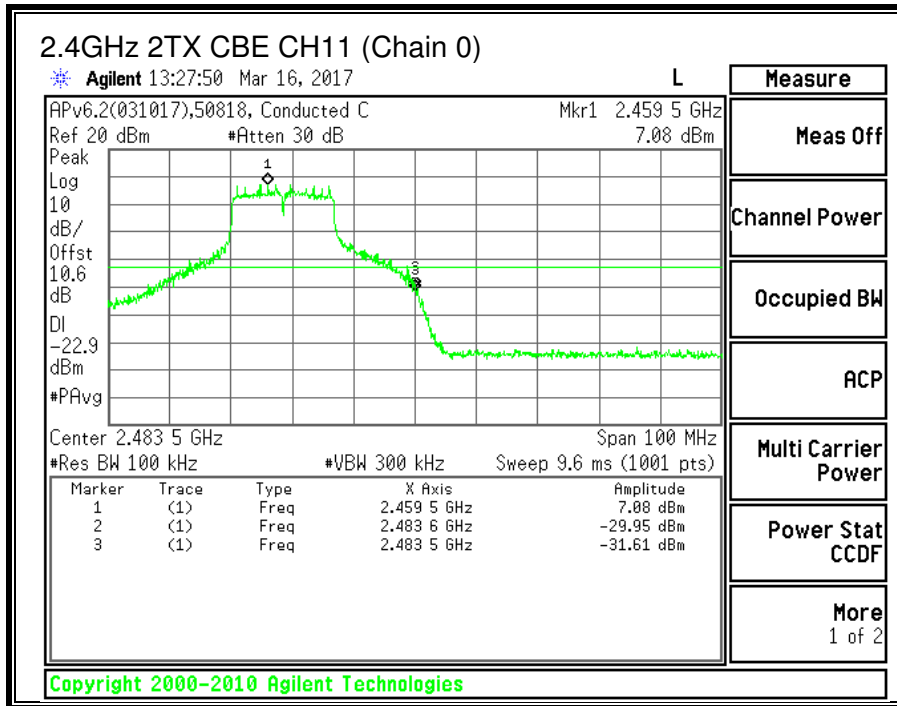

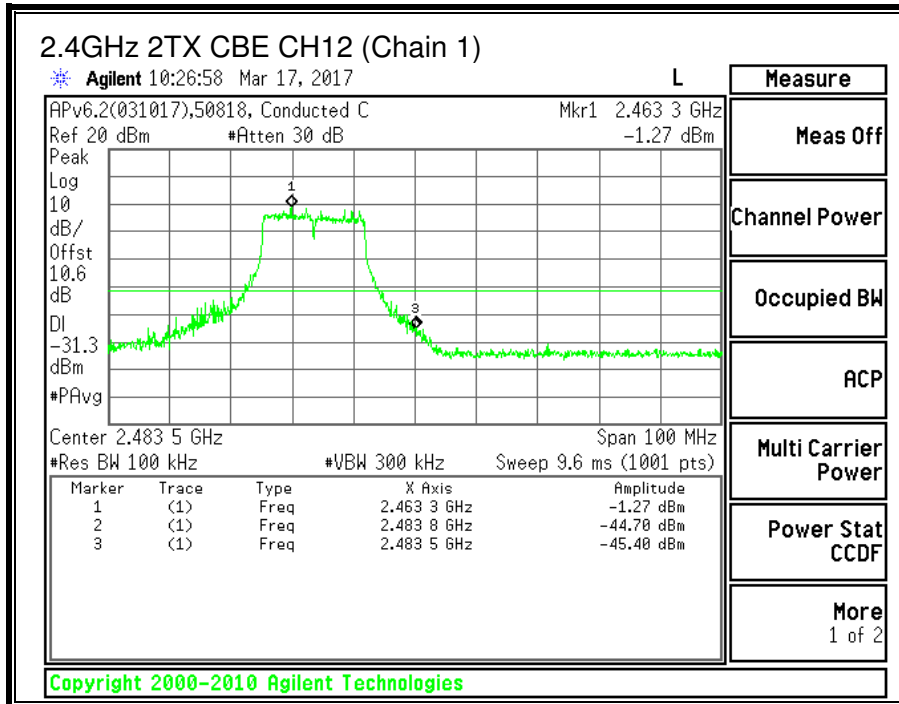
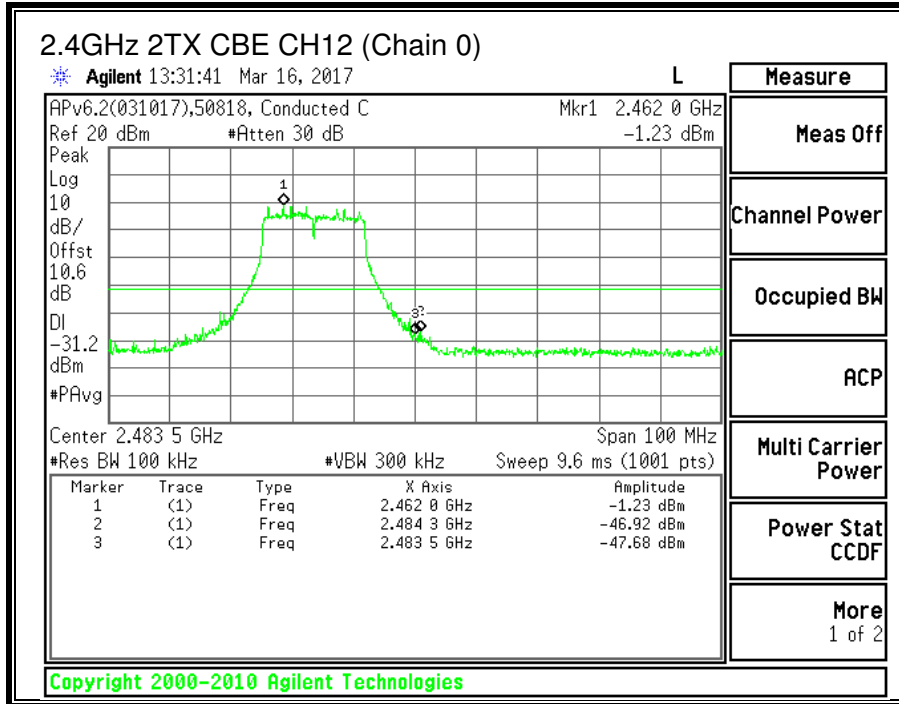

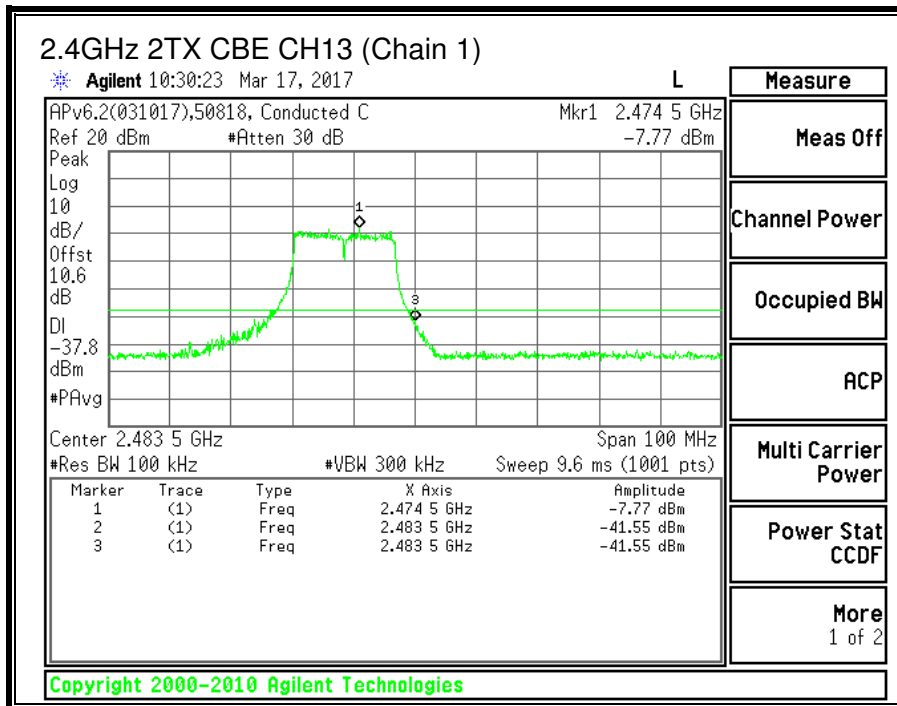
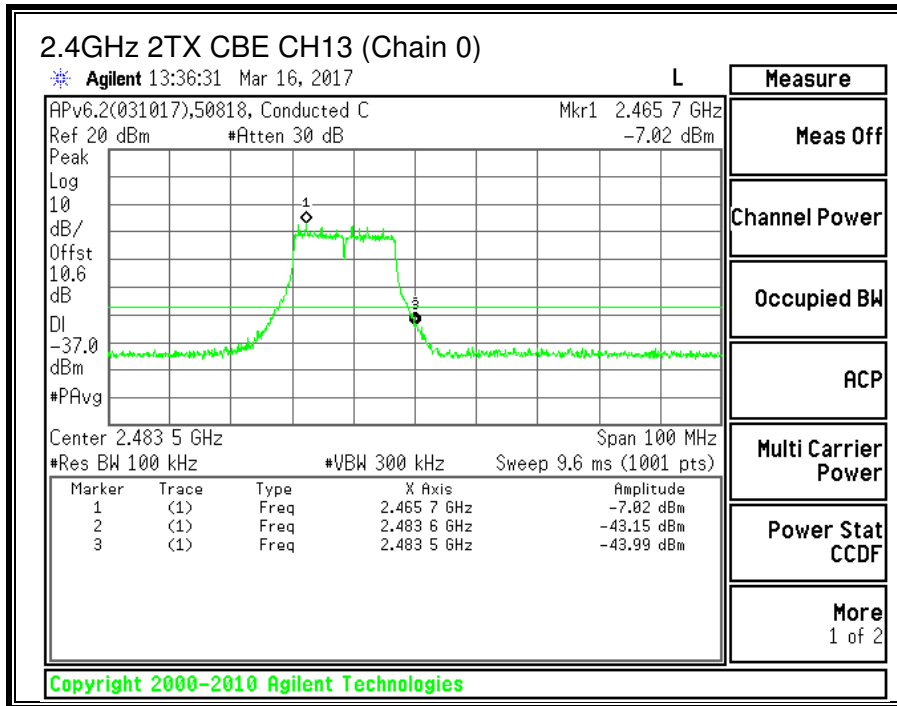

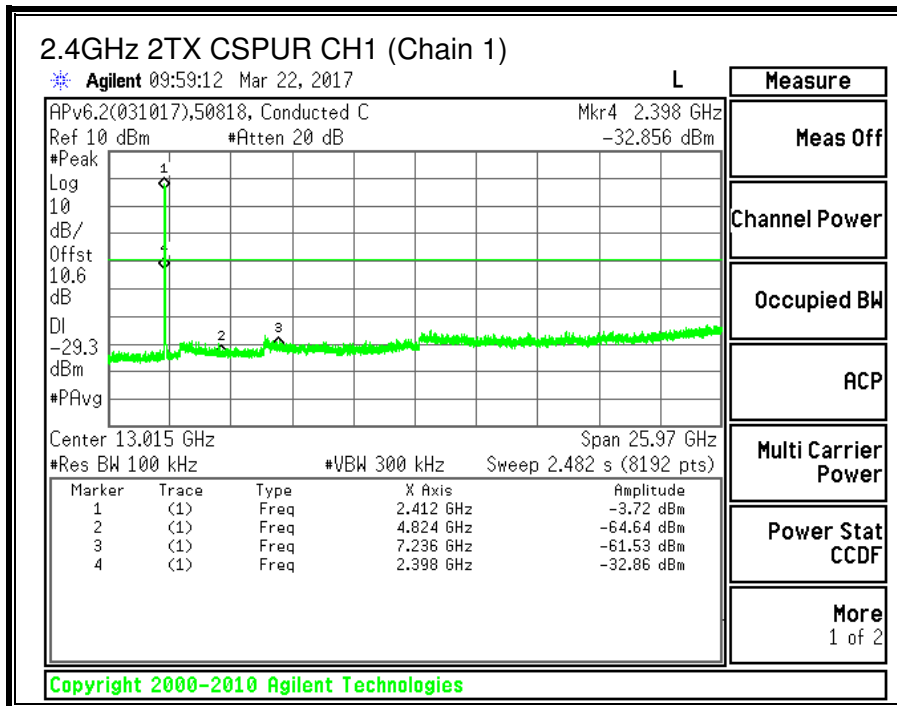
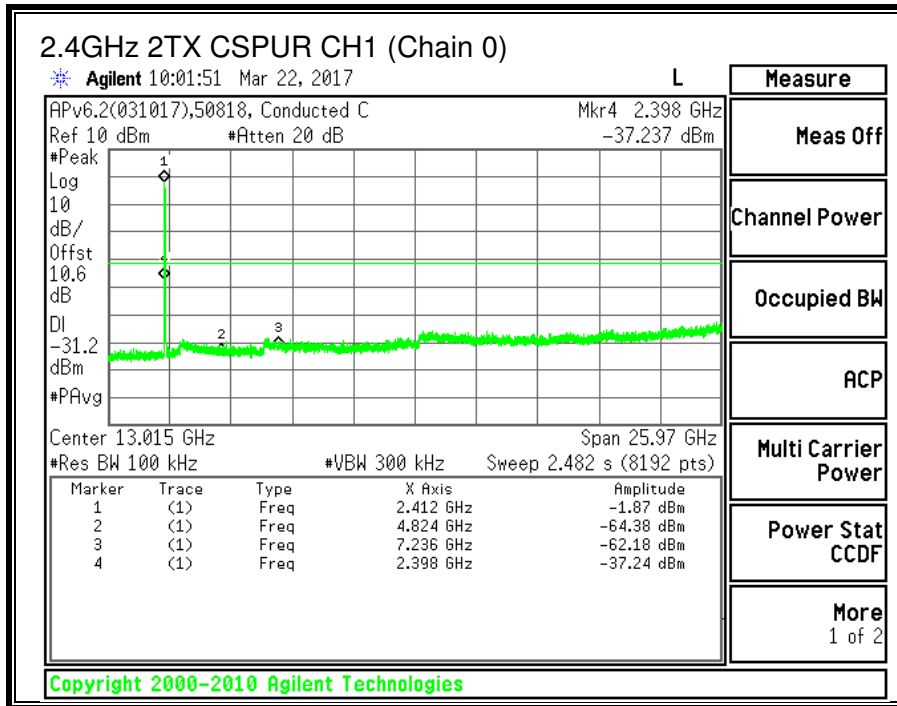

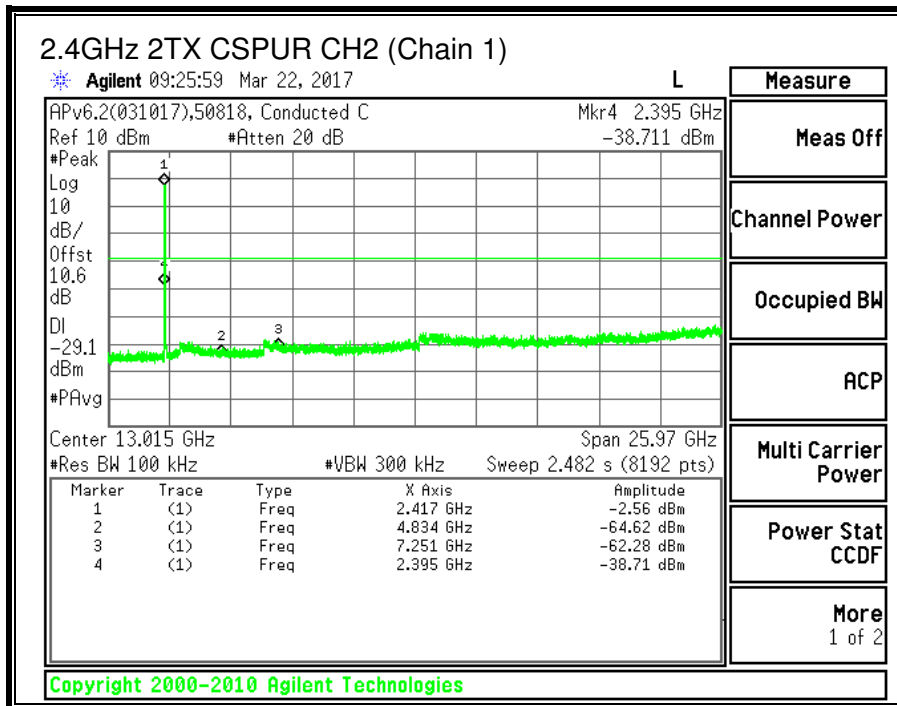
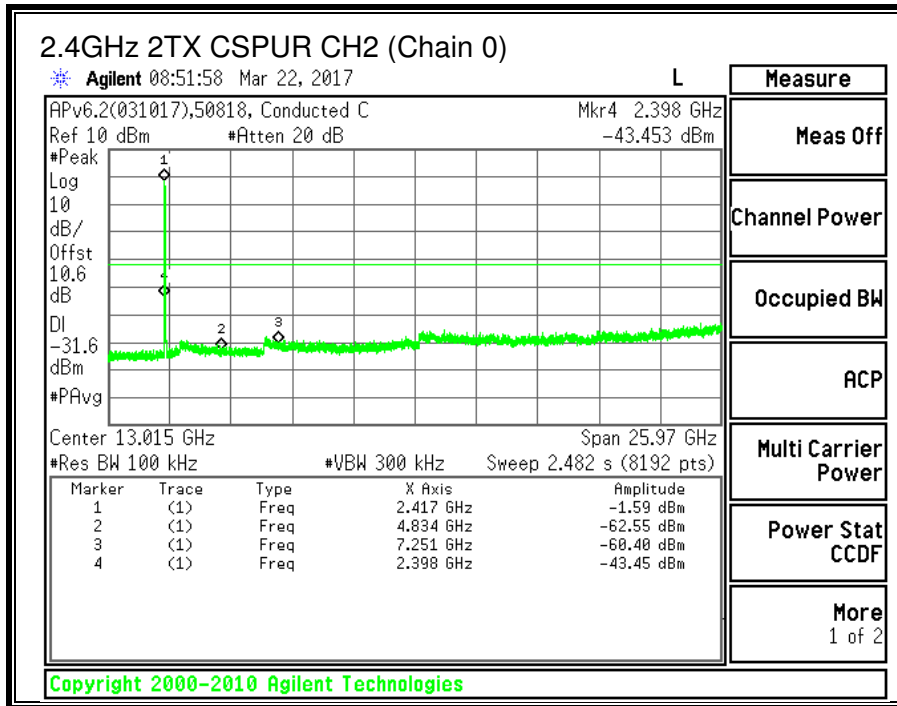

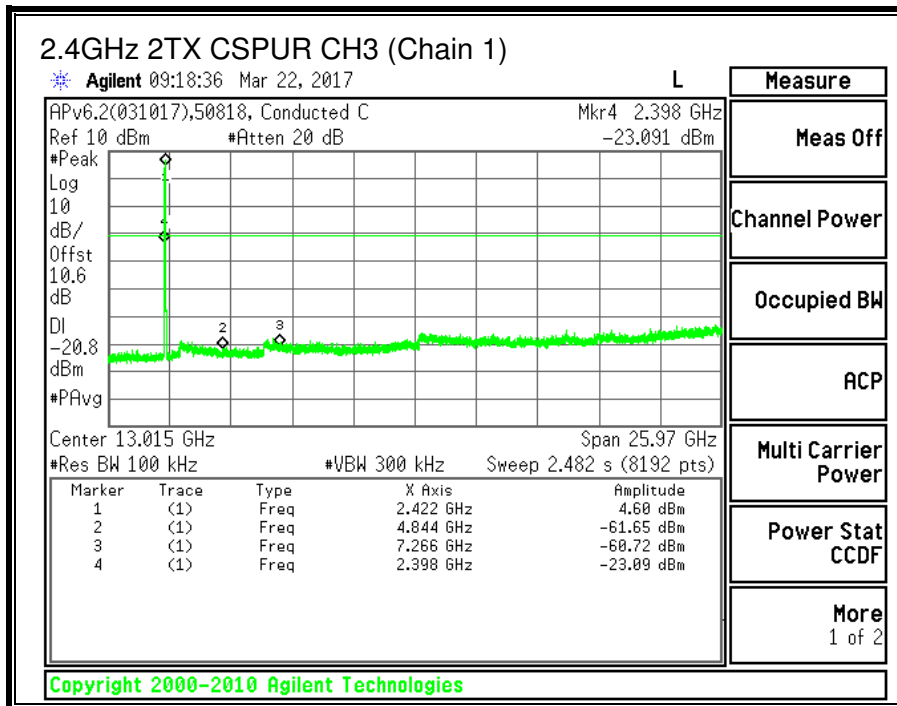
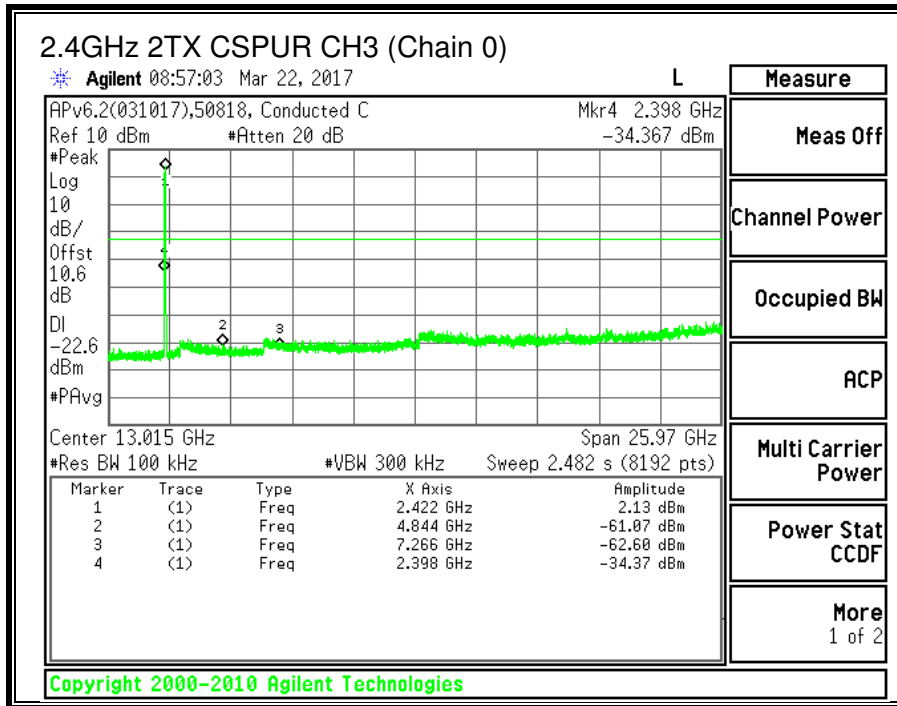

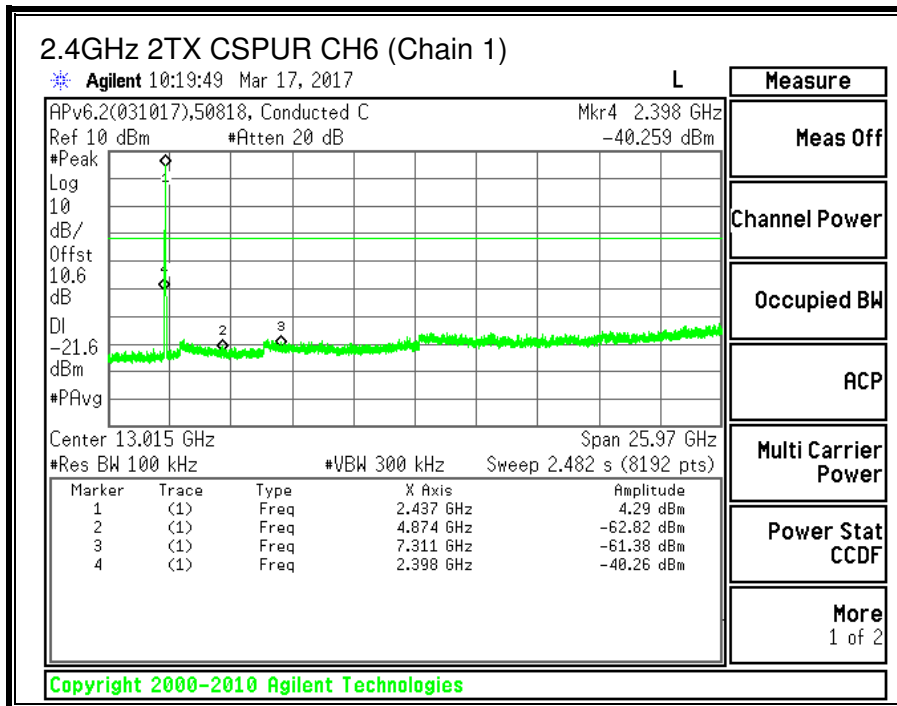
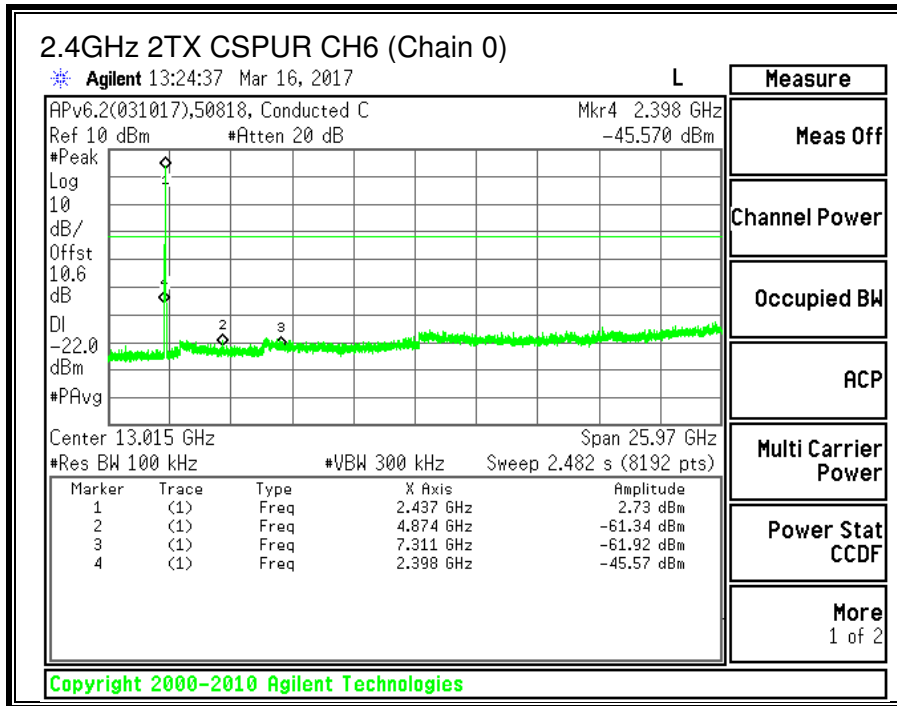

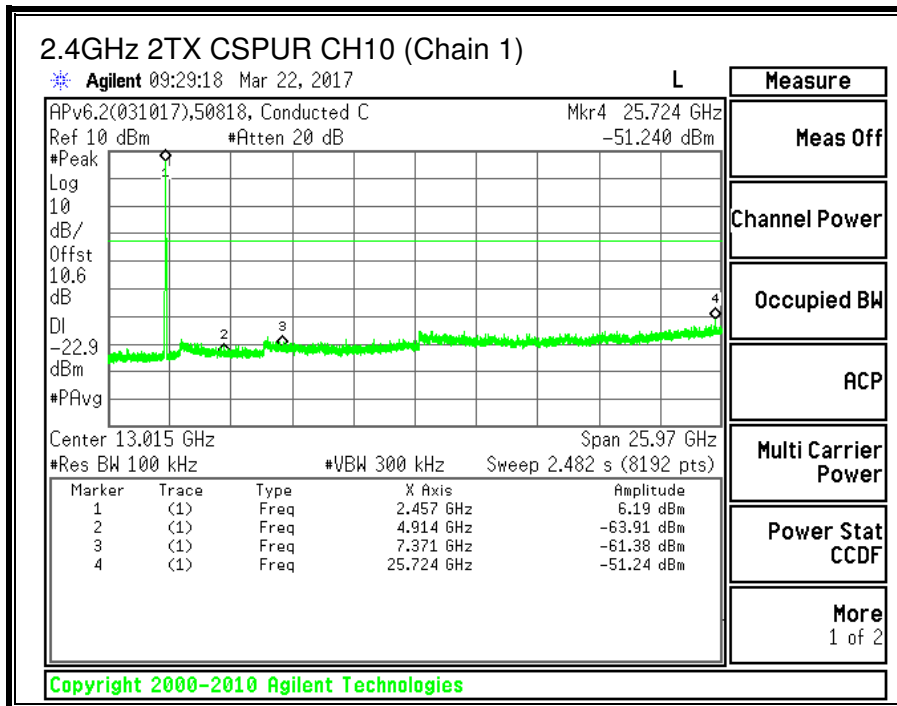
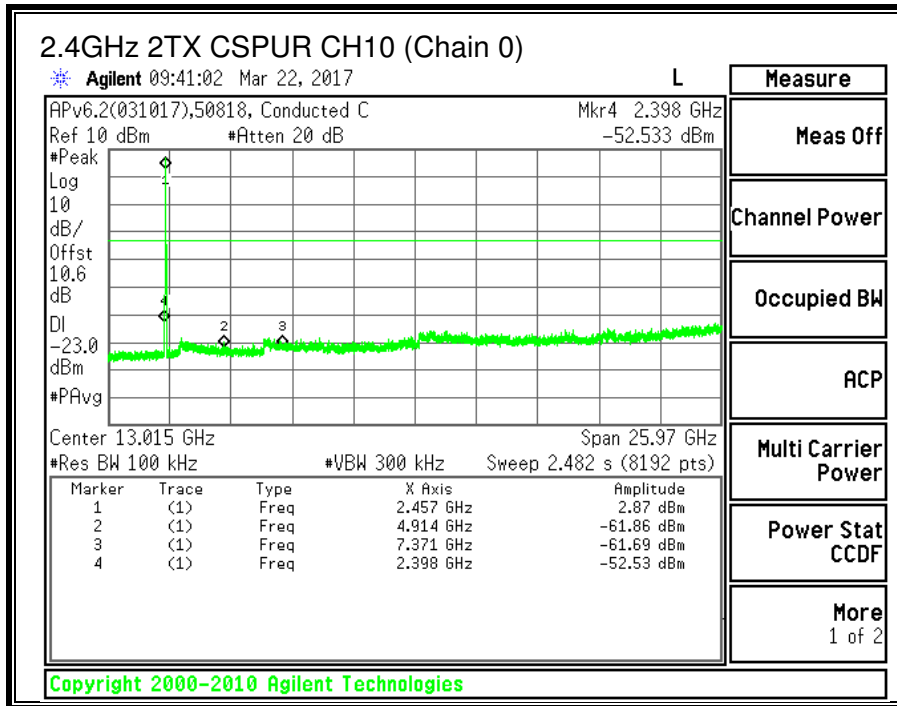

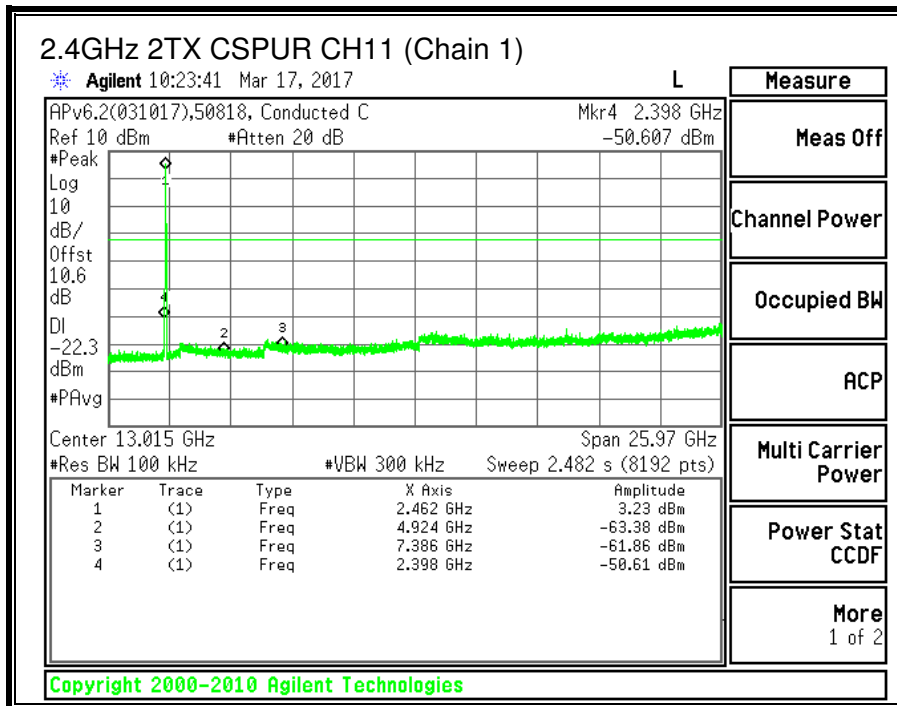
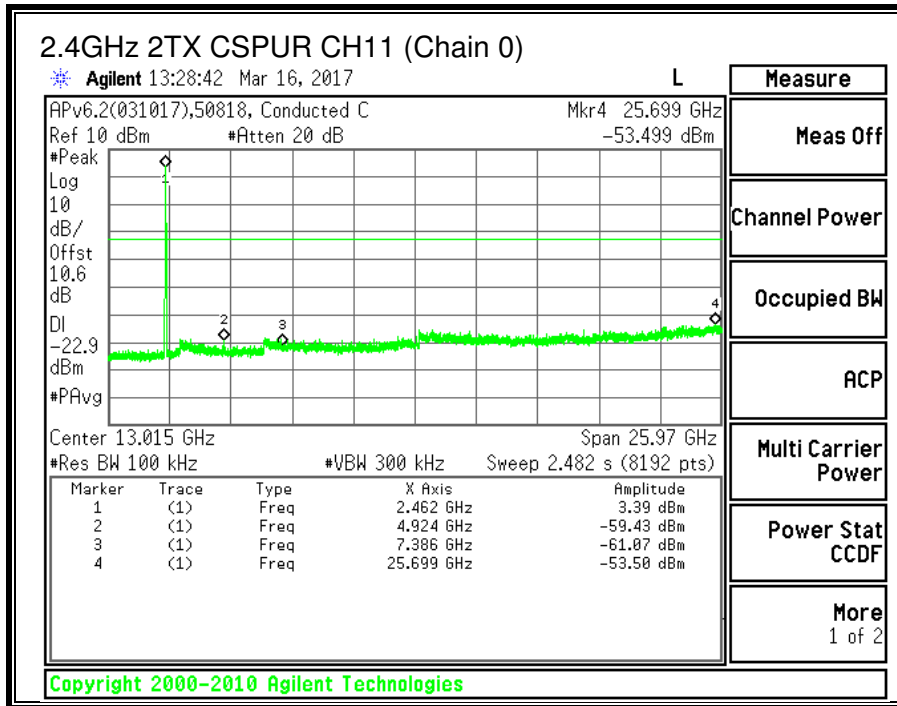

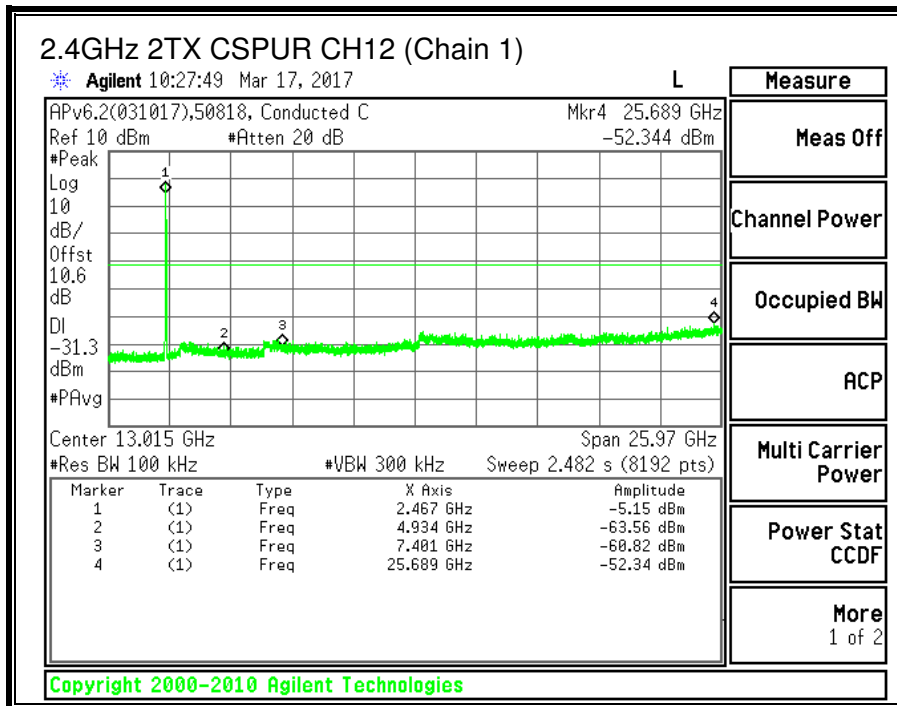
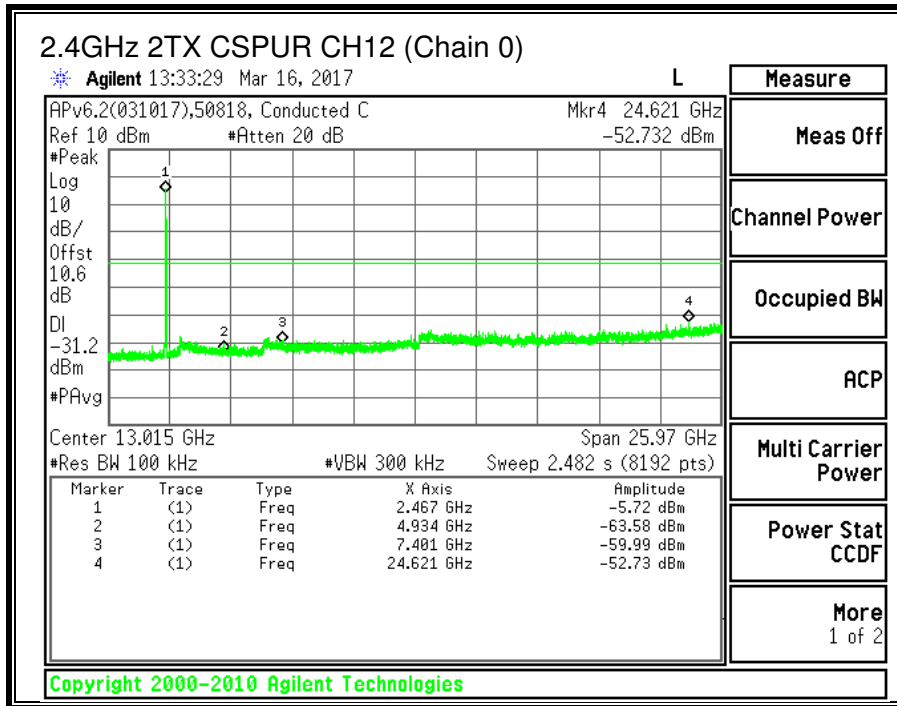

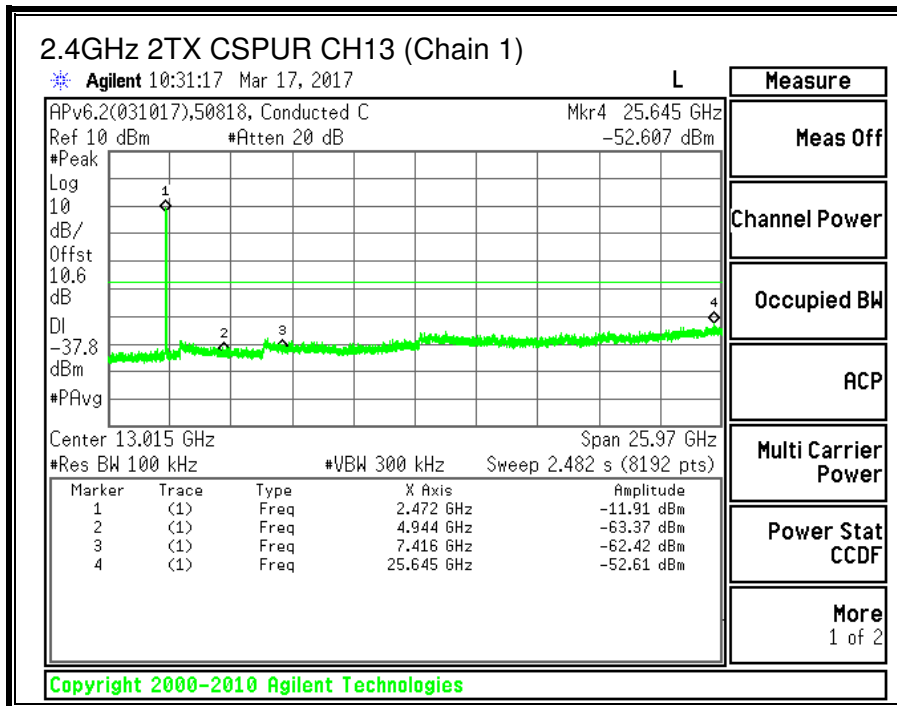
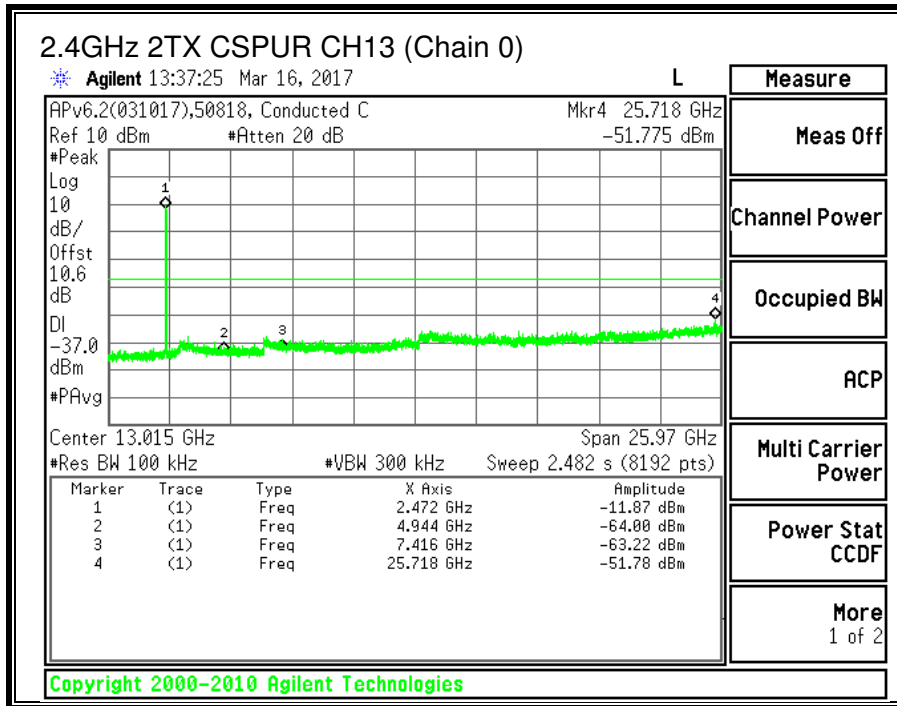

9.4. 11n HT20 2TX CDD MIMO MODE IN THE 2.4GHz BAND

9.4.1. 6 dB BANDWIDTH

LIMITS

FCC §15.247 (a) (2)

The minimum 6 dB bandwidth shall be at least 500 kHz.

RESULTS

Channel	Frequency	6 dB BW Chain 0 (MHz)	6 dB BW Chain 1 (MHz)	Minimum Limit (MHz)
CH1	2412	17.635	17.160	0.5
CH2	2417	17.585	17.610	0.5
CH3	2422	17.600	17.530	0.5
CH6	2437	15.130	16.915	0.5
CH10	2457	17.650	17.675	0.5
CH11	2462	17.315	17.550	0.5
CH12	2467	17.560	17.695	0.5
CH13	2472	16.565	15.040	0.5

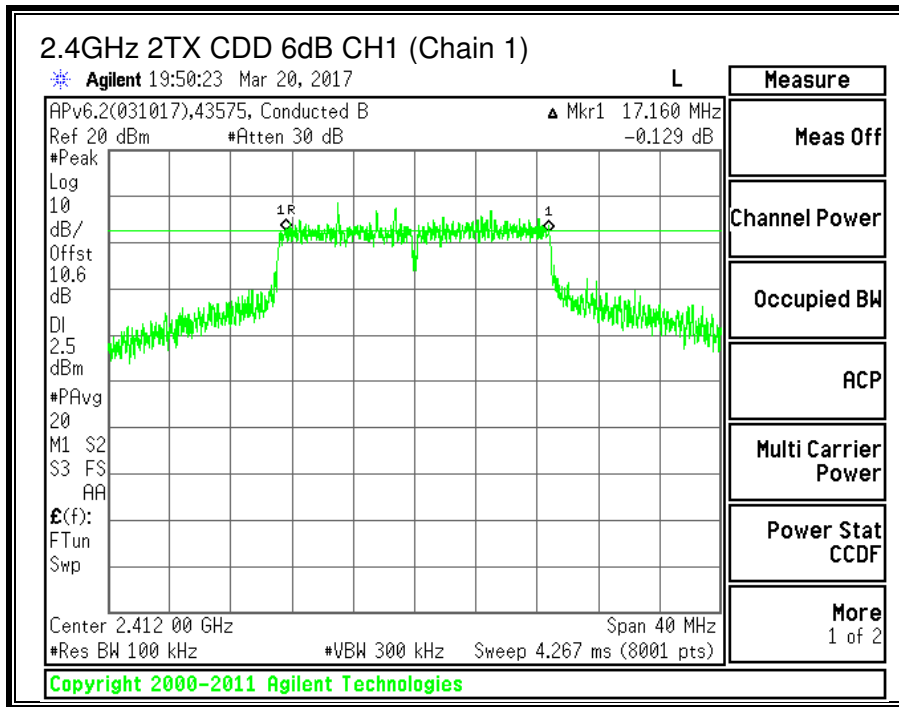
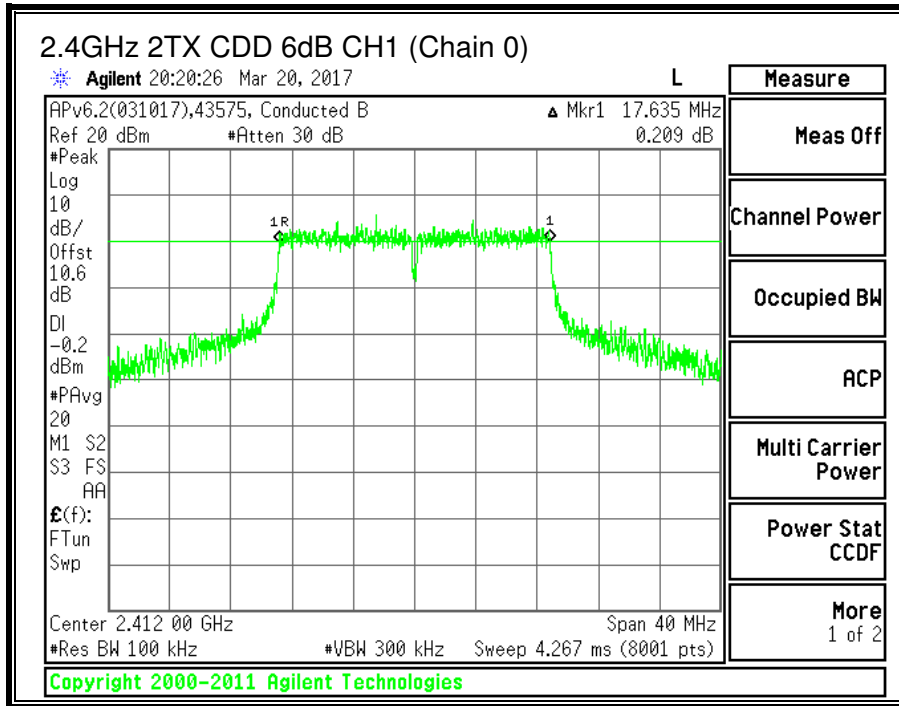

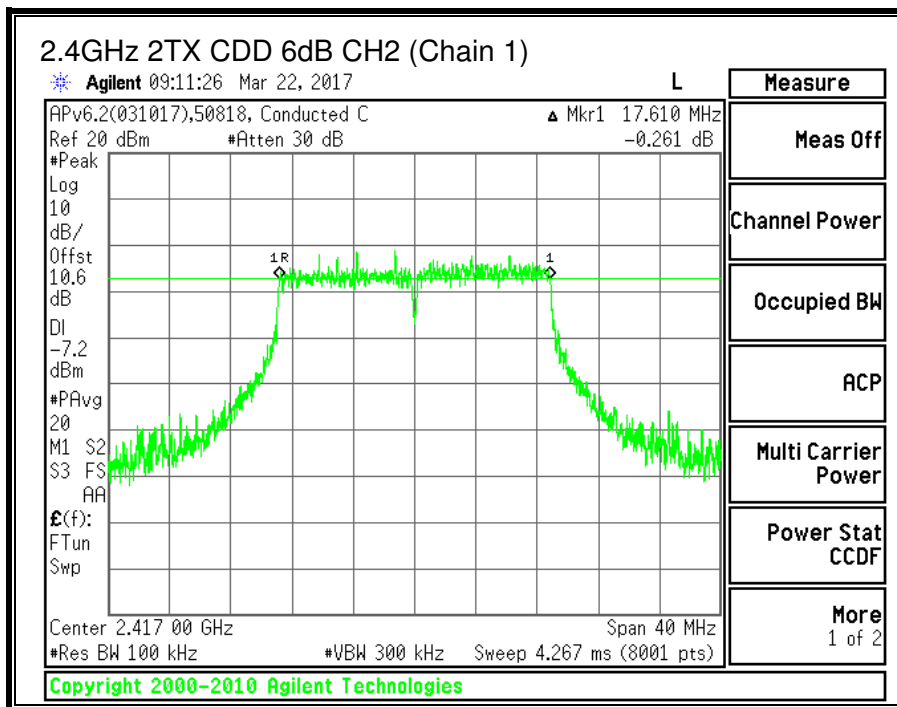
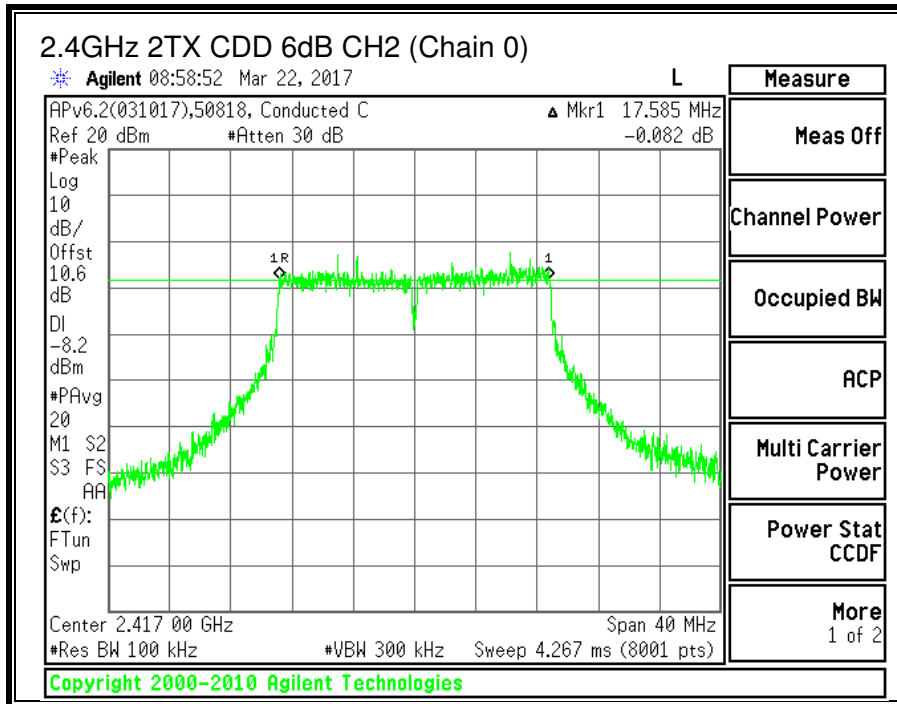

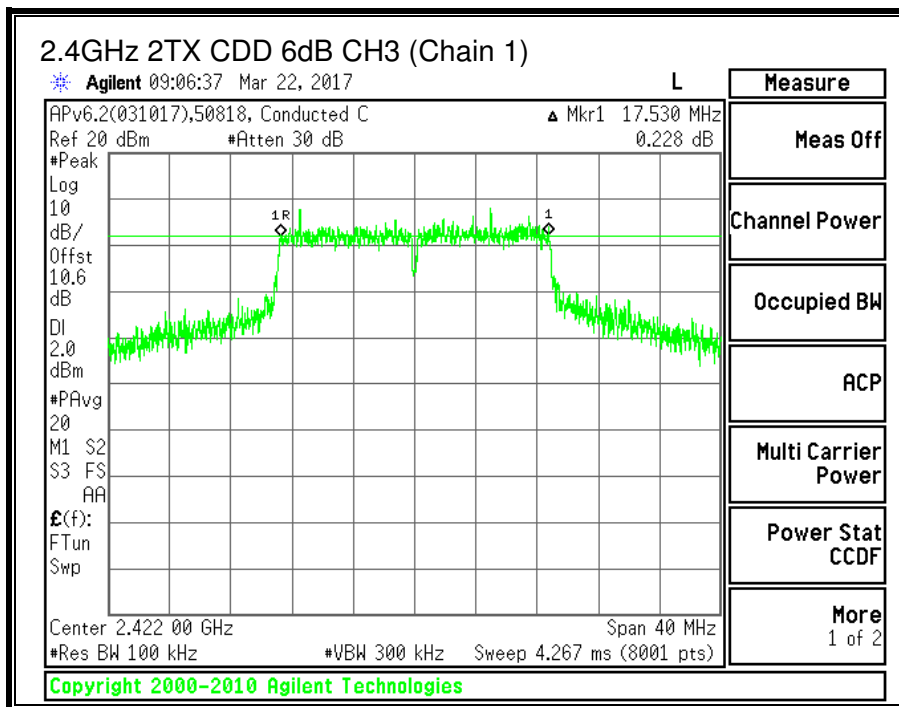
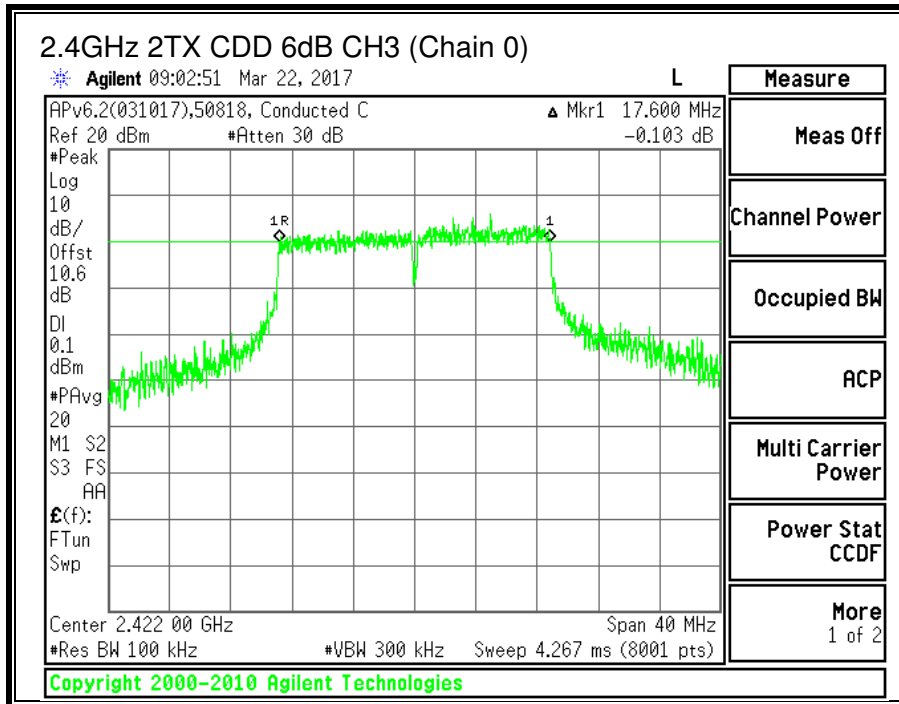

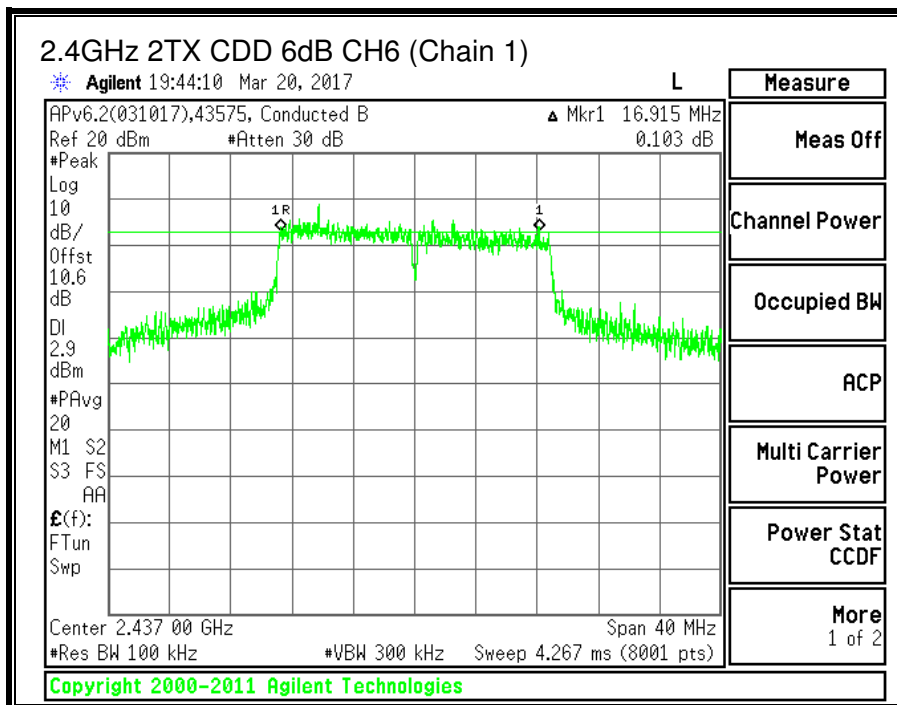
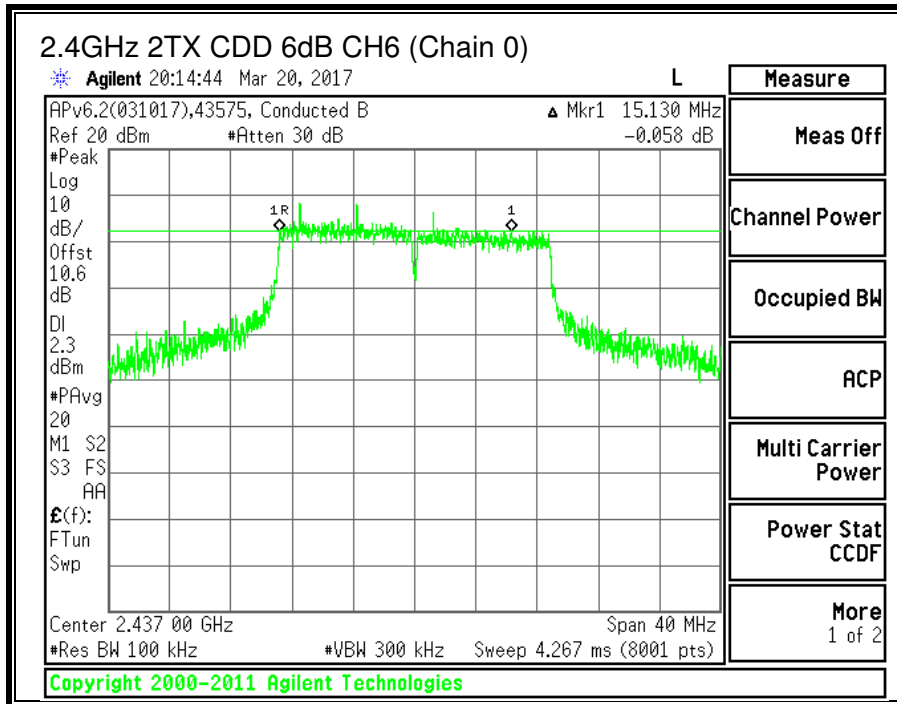

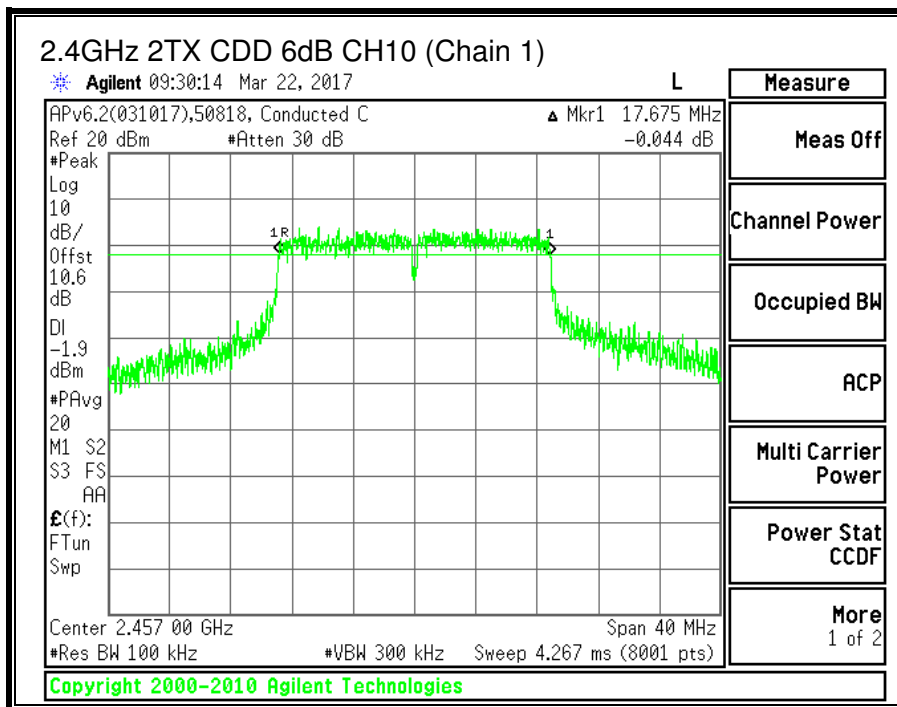
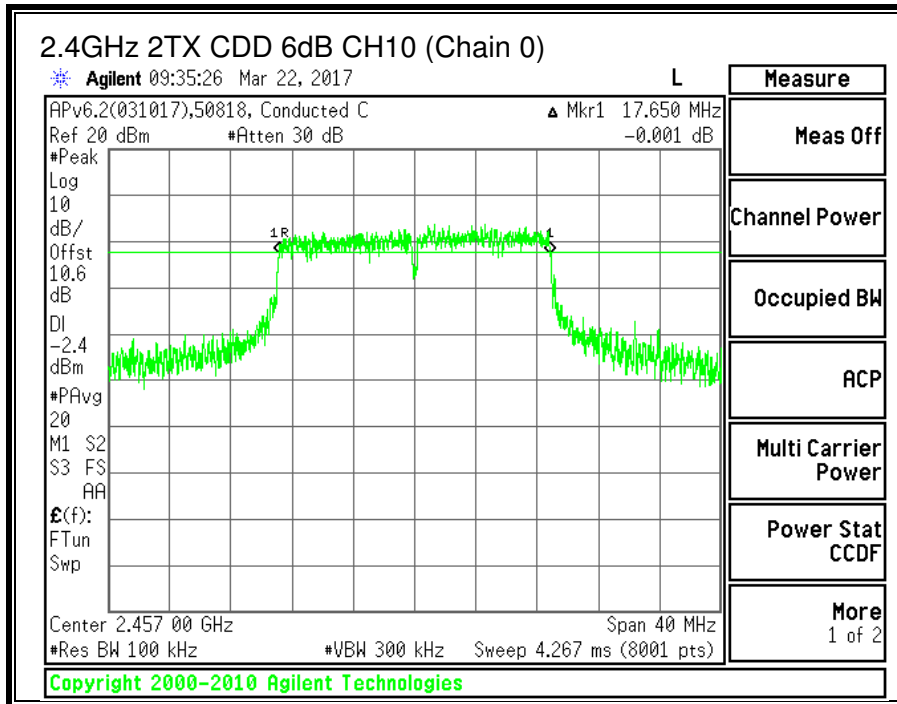

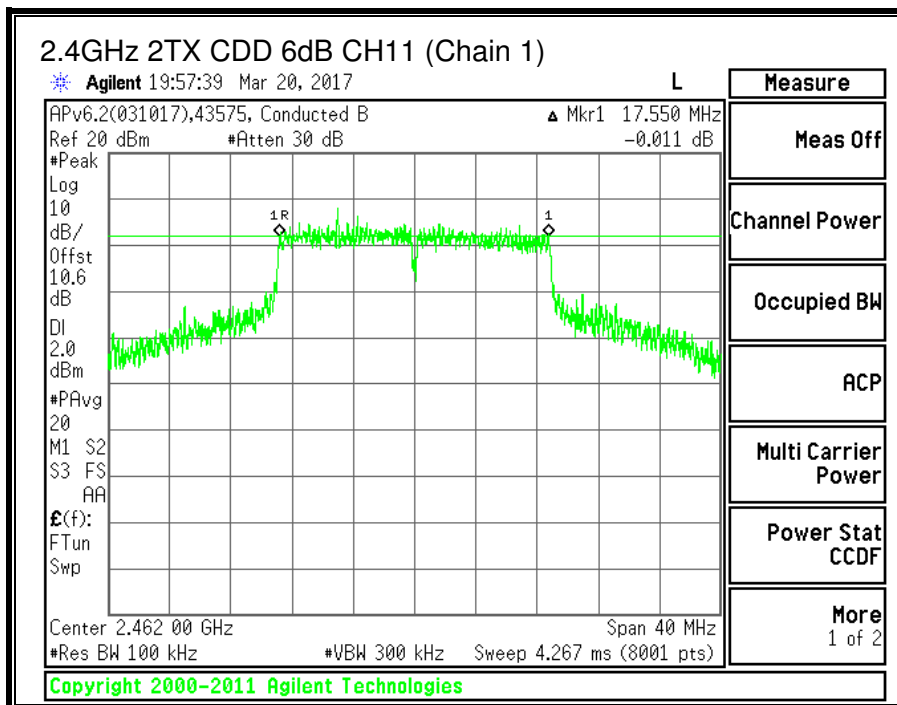
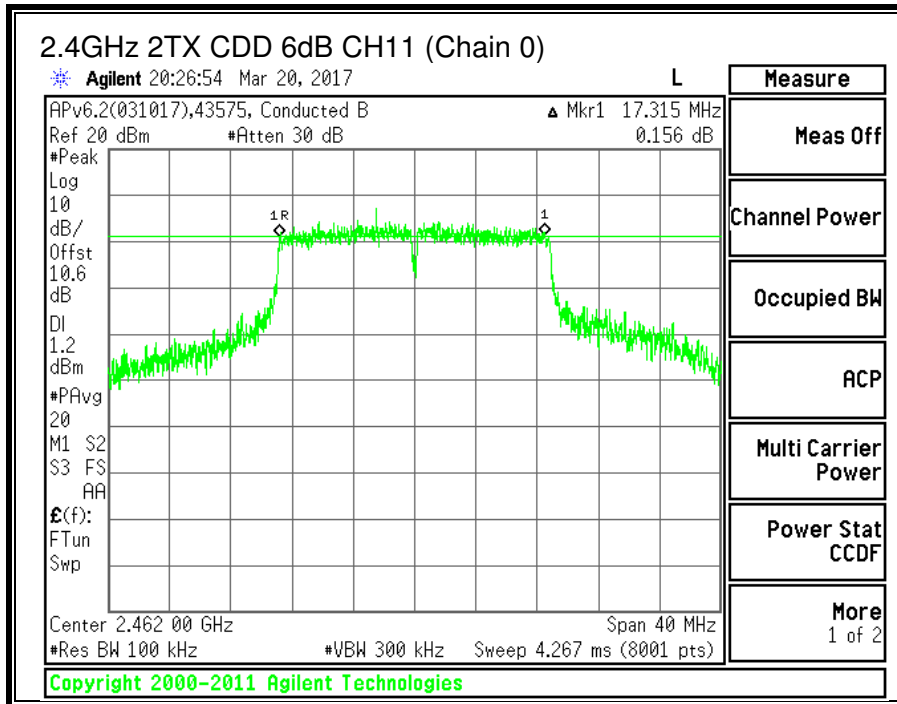

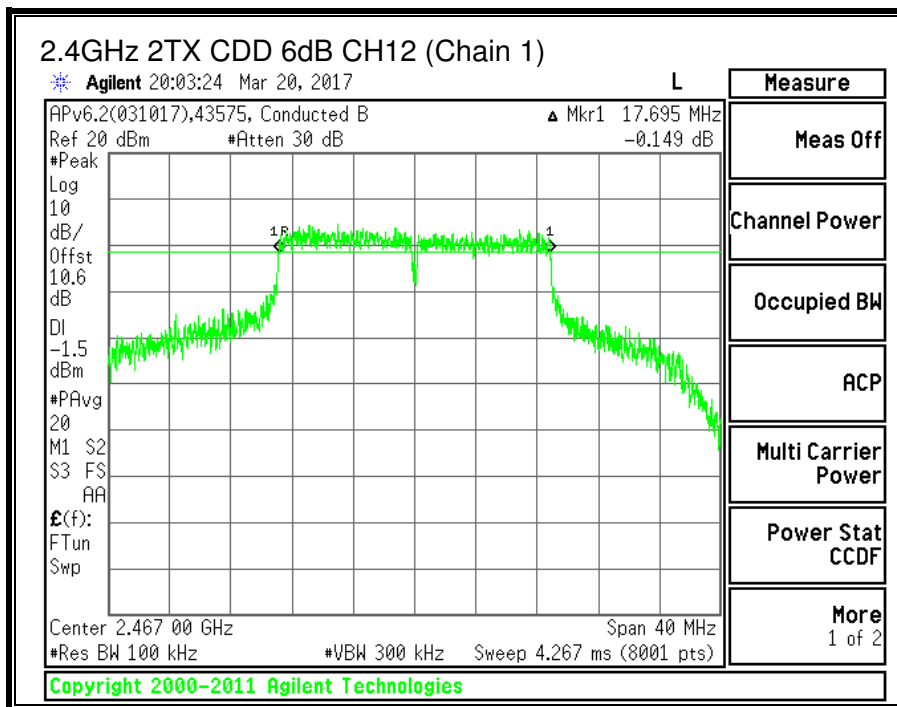
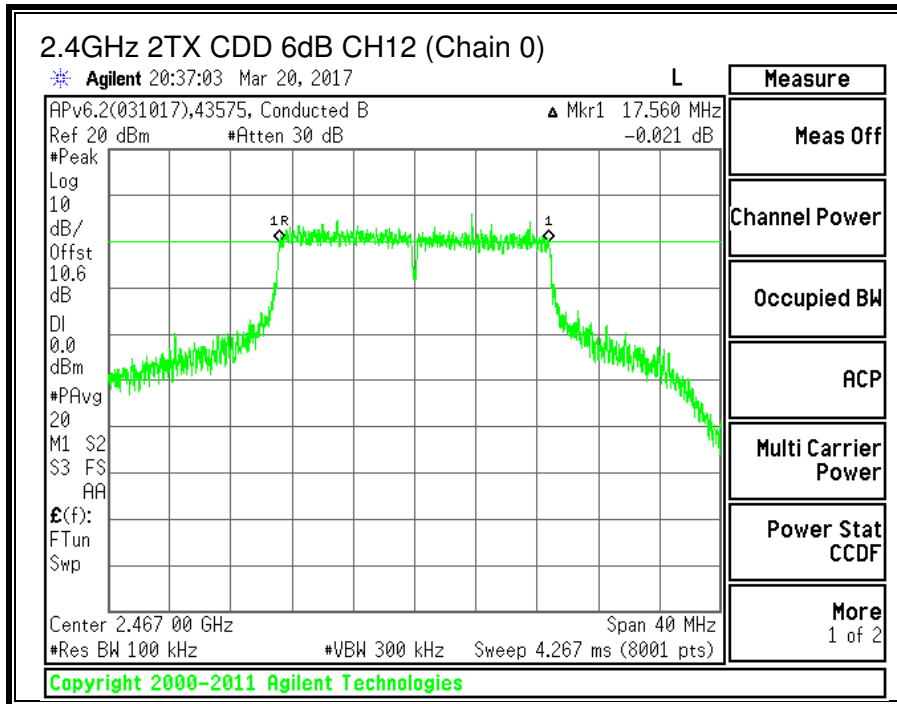

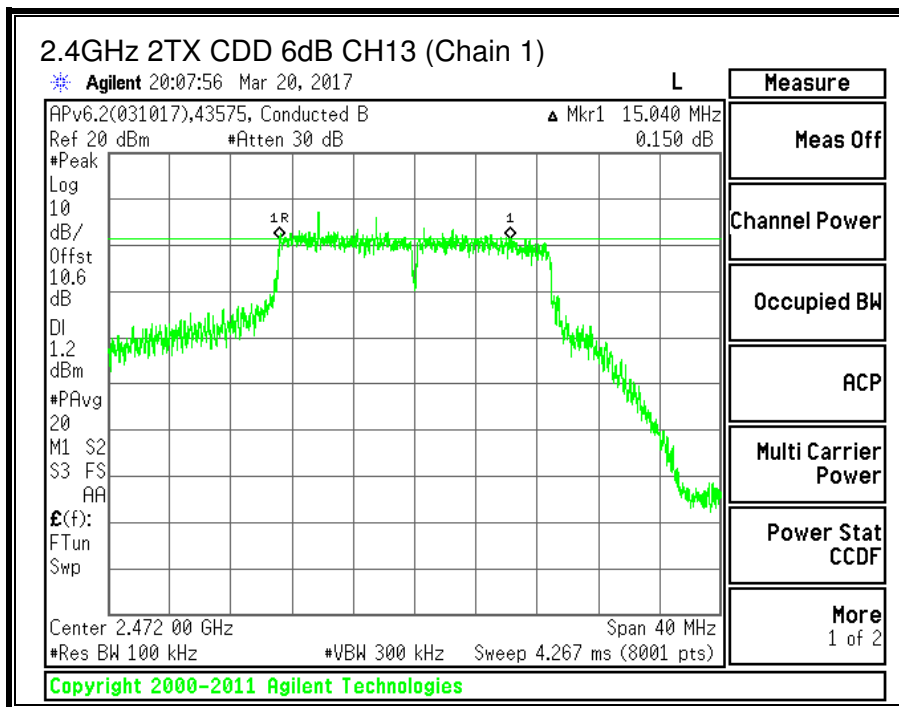
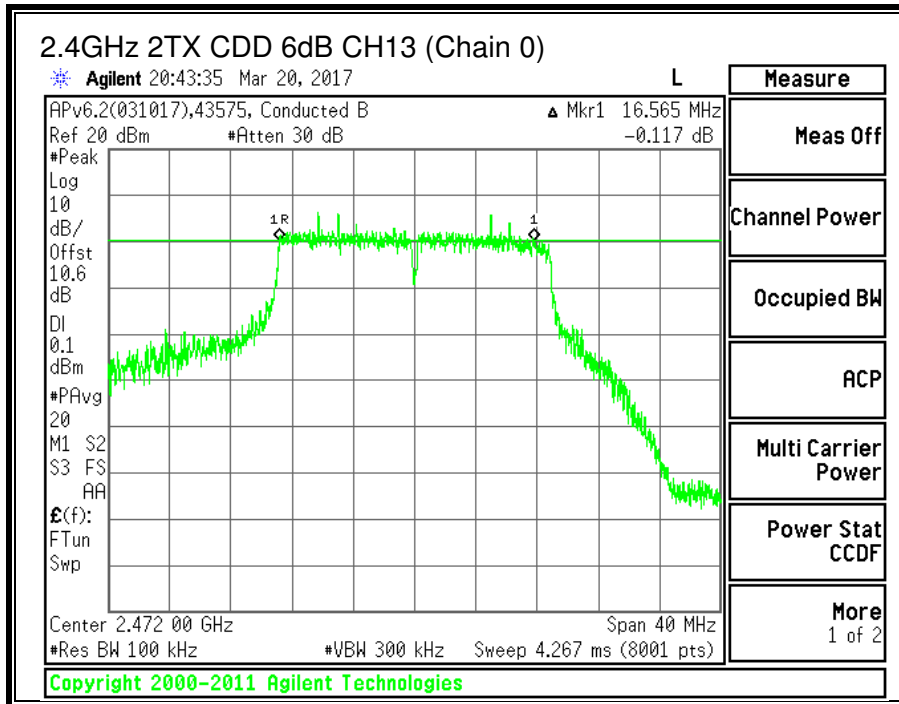

9.4.2. 99% BANDWIDTH

LIMITS

None; for reporting purposes only.

RESULTS

Channel	Frequency (MHz)	99% Bandwidth Chain 0 (MHz)	99% Bandwidth Chain 1 (MHz)
CH1	2412	17.5070	18.2939
CH2	2417	17.5661	17.5116
CH3	2422	17.5245	19.2235
CH6	2437	17.7431	19.1249
CH10	2457	17.7486	17.6979
CH11	2462	17.5616	18.3052
CH12	2467	17.6230	18.1895
CH13	2472	17.5879	18.5443

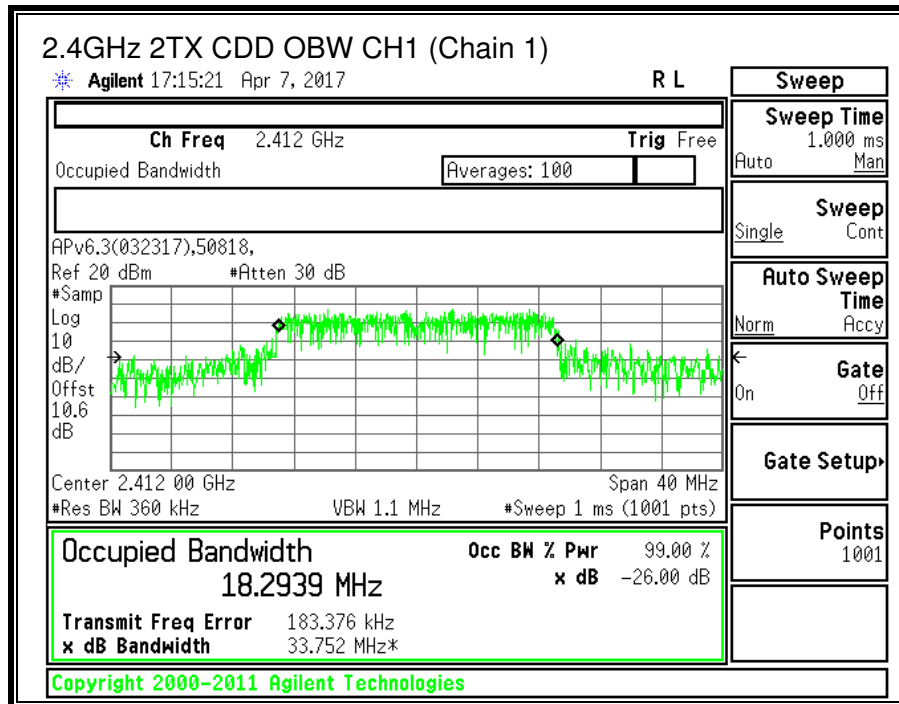
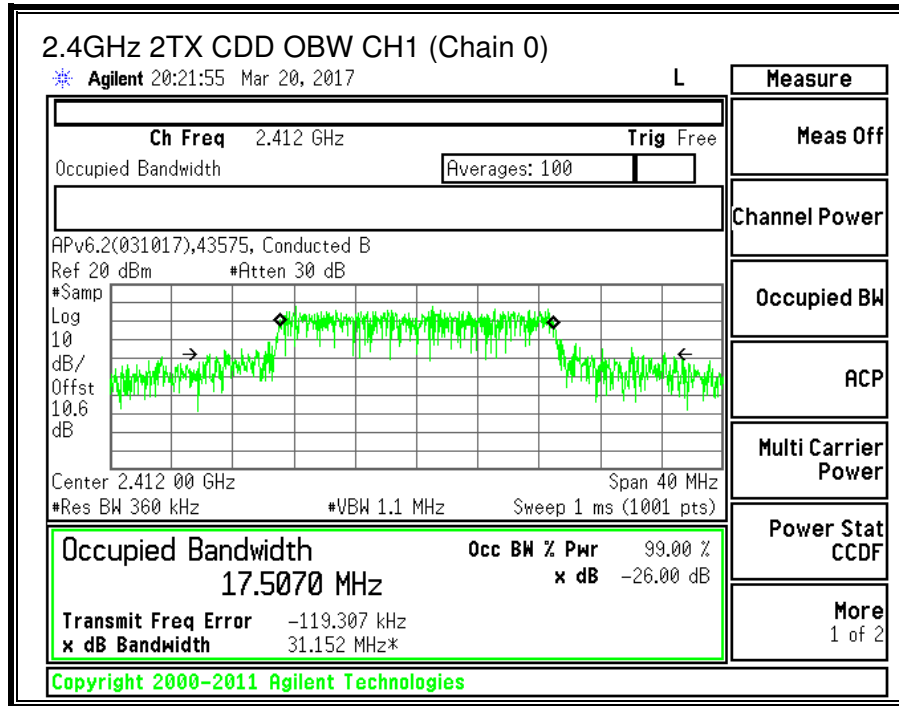

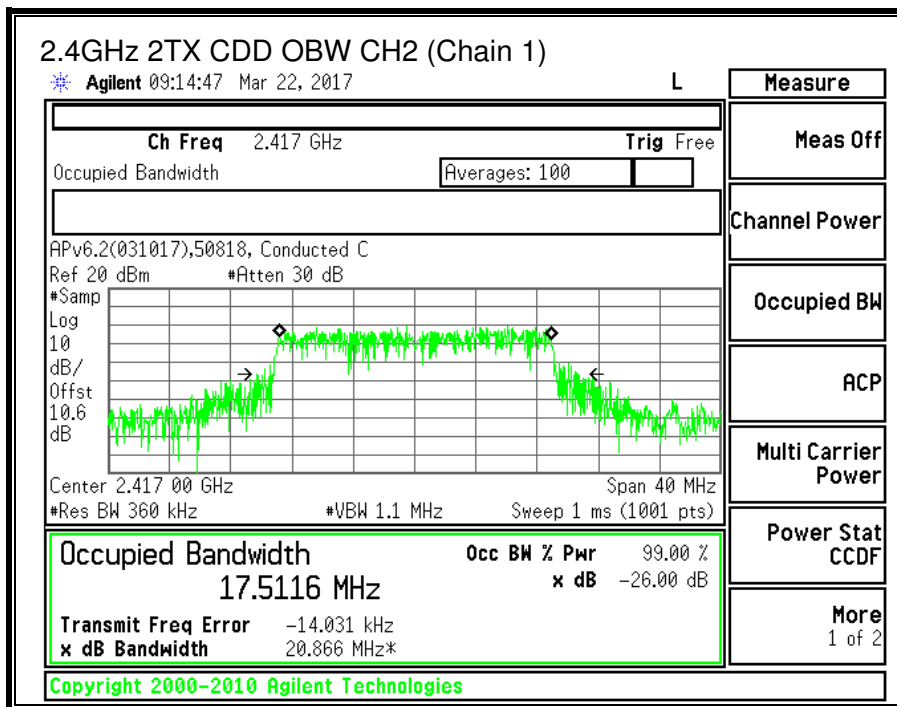
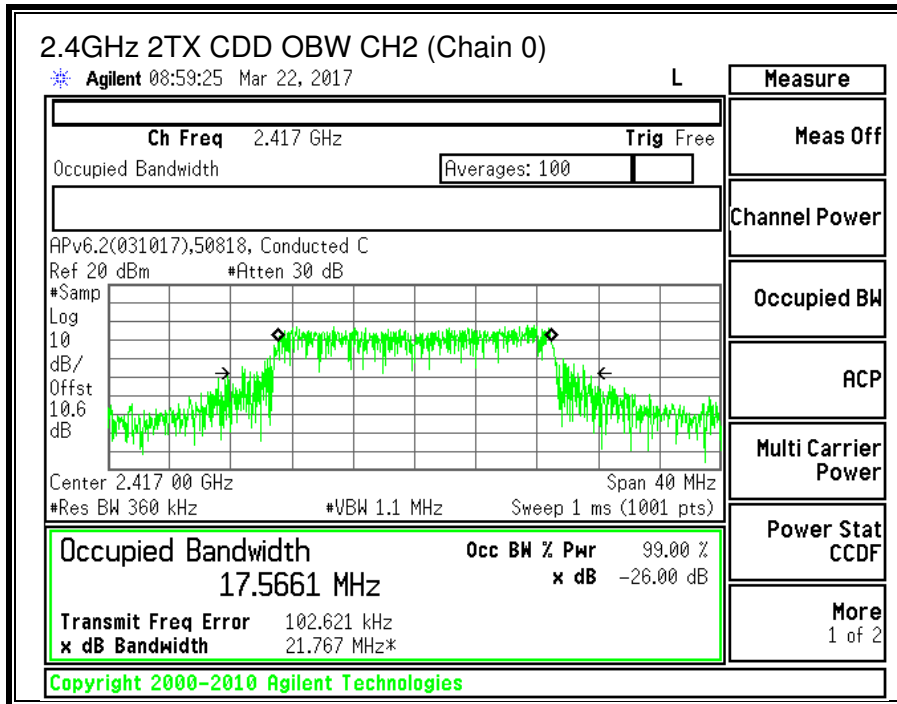

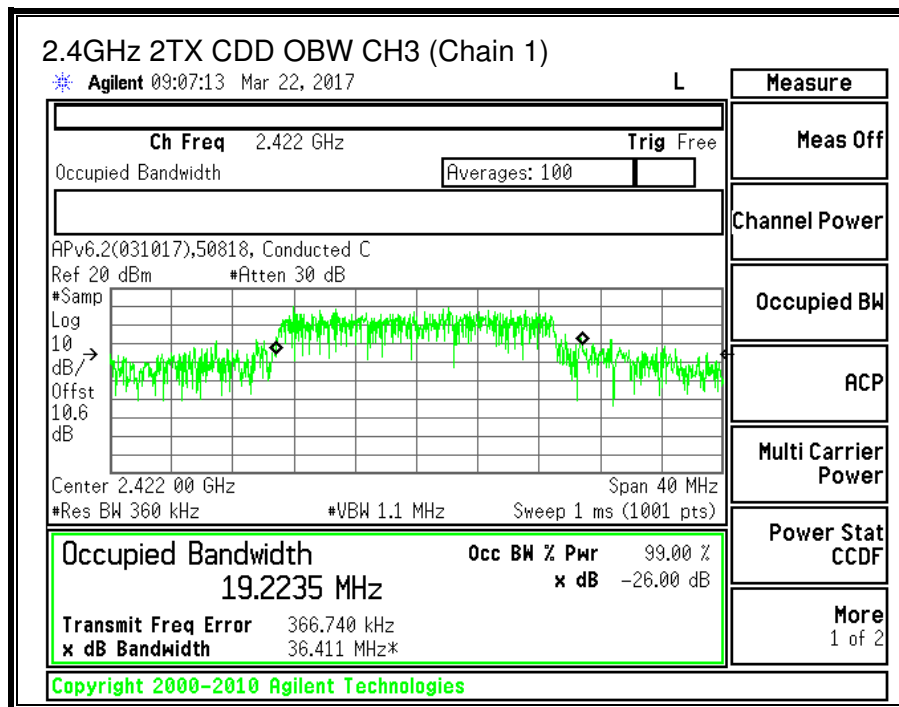
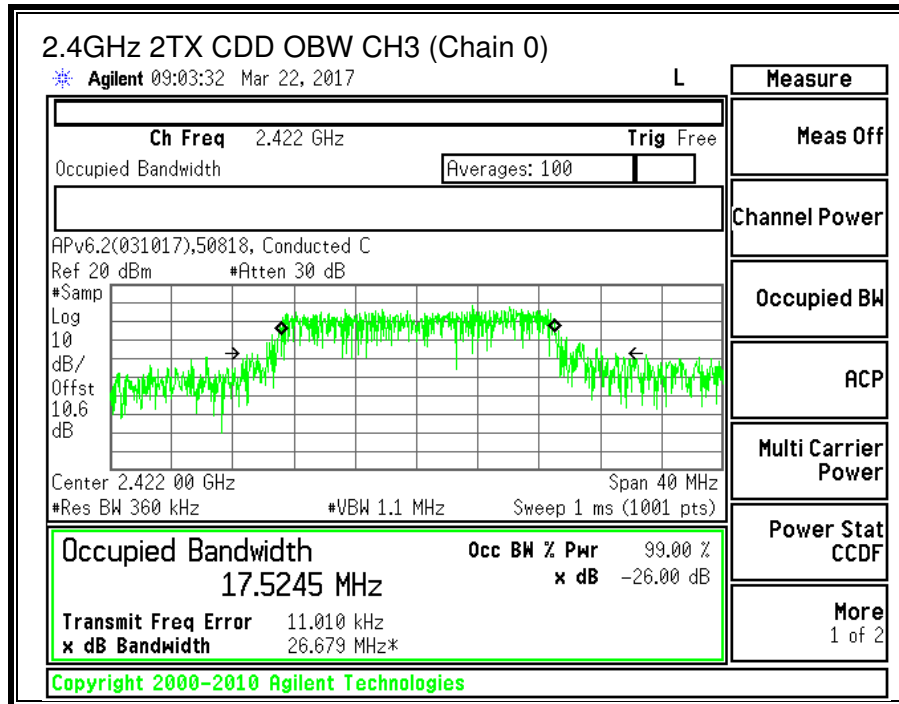

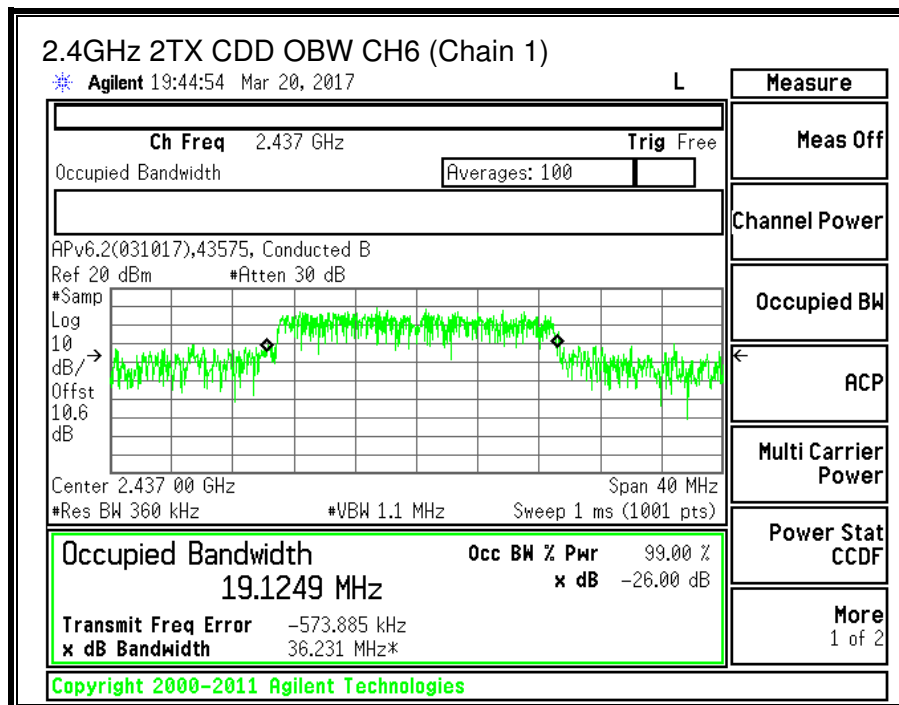
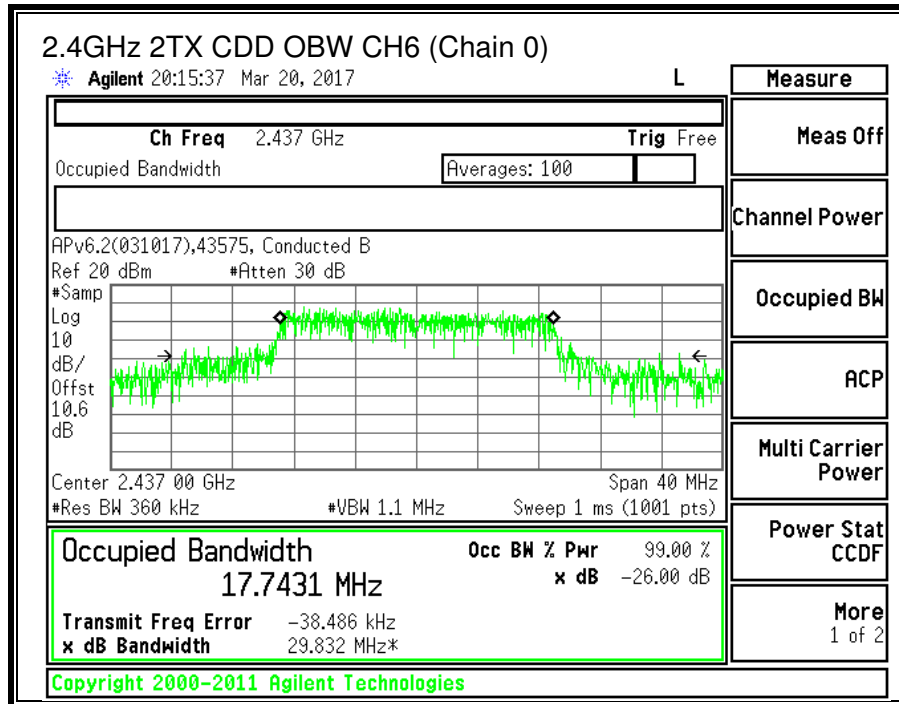

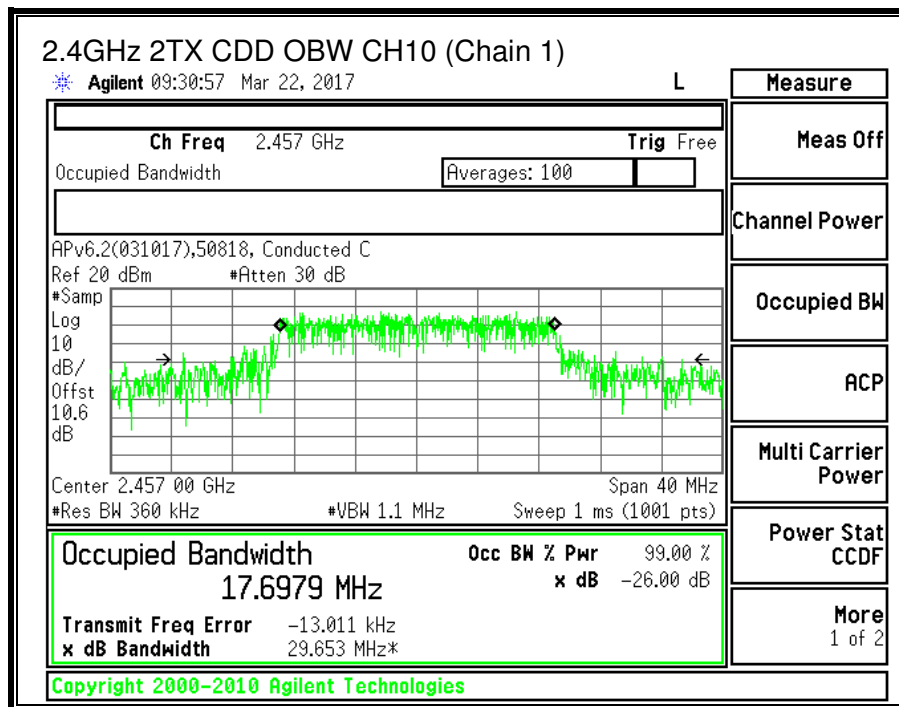
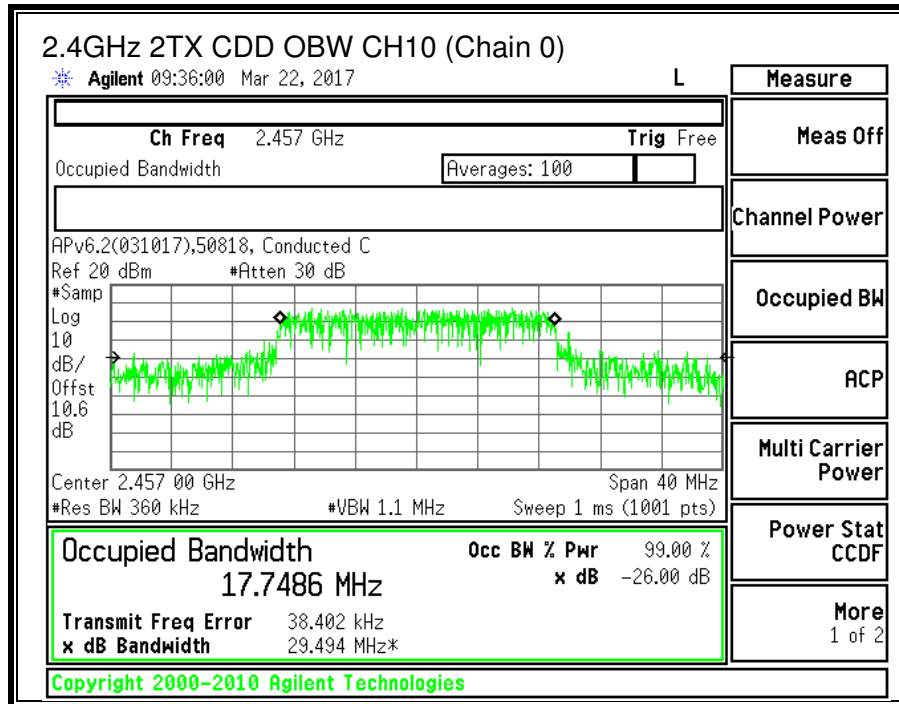

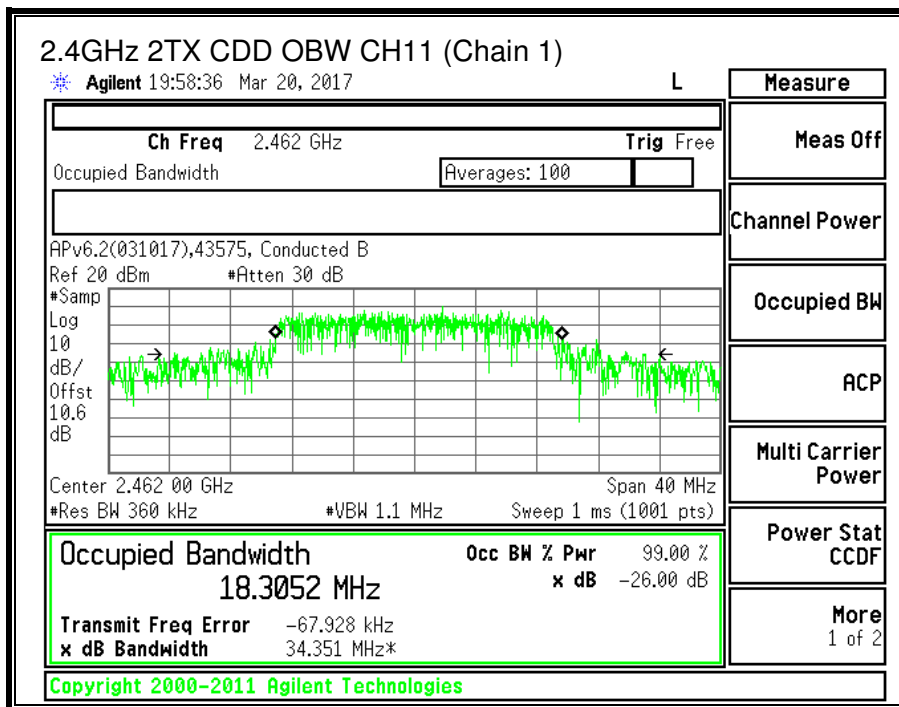
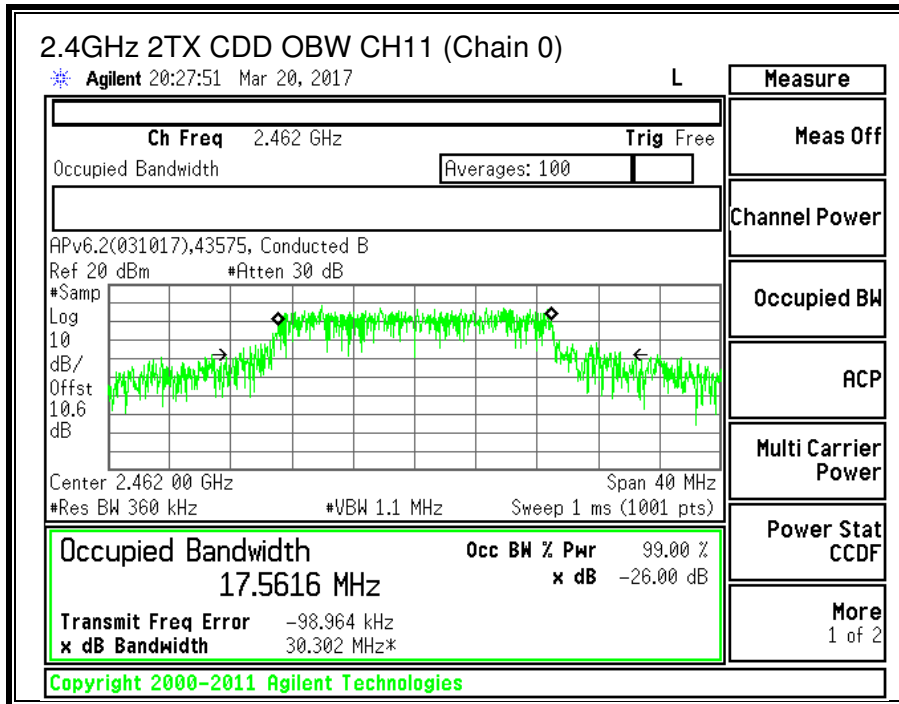

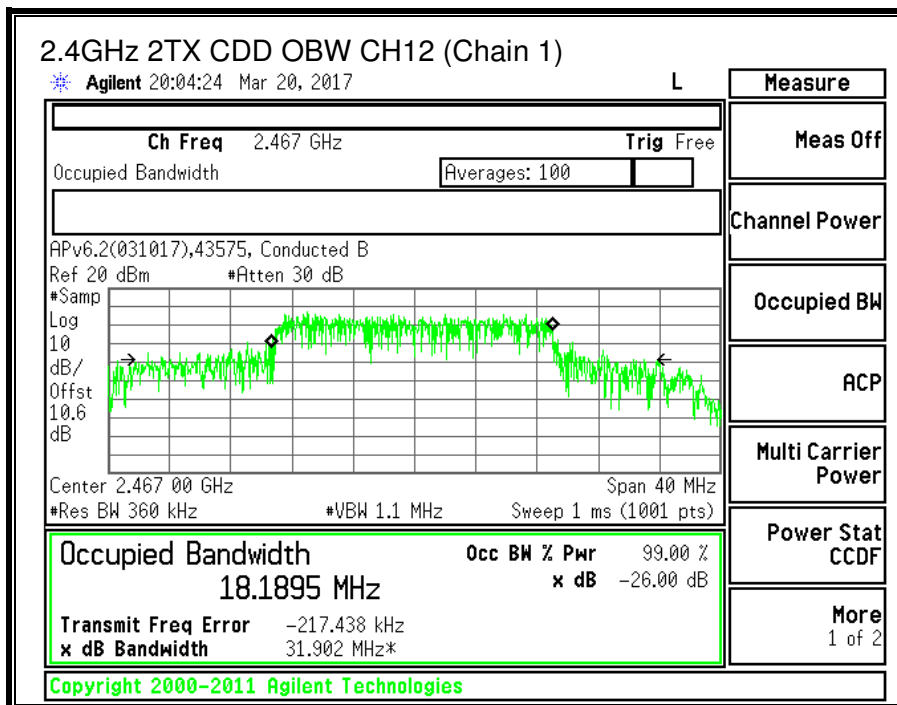
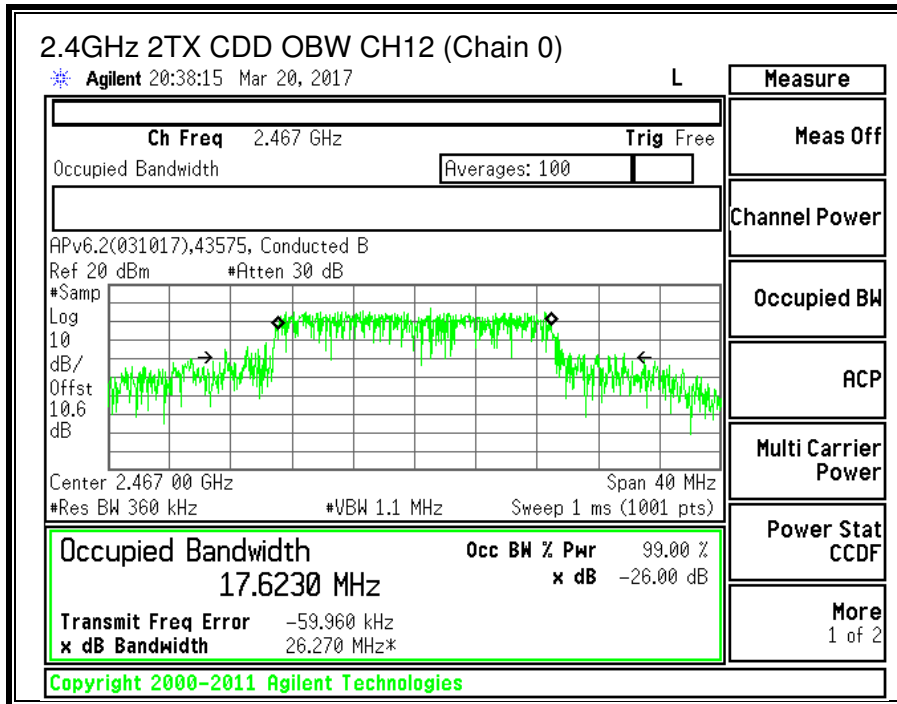

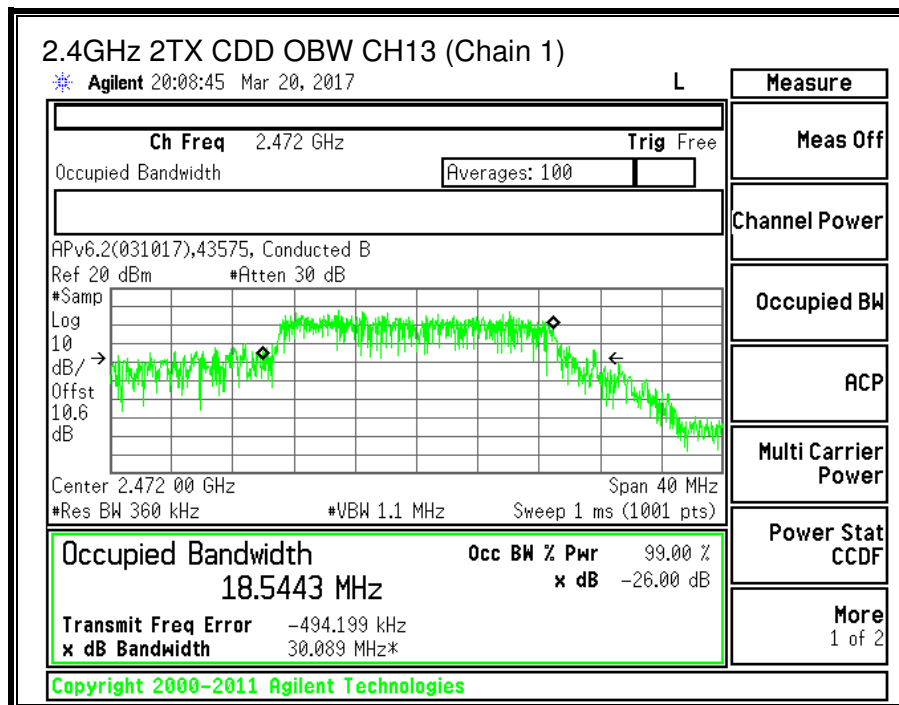
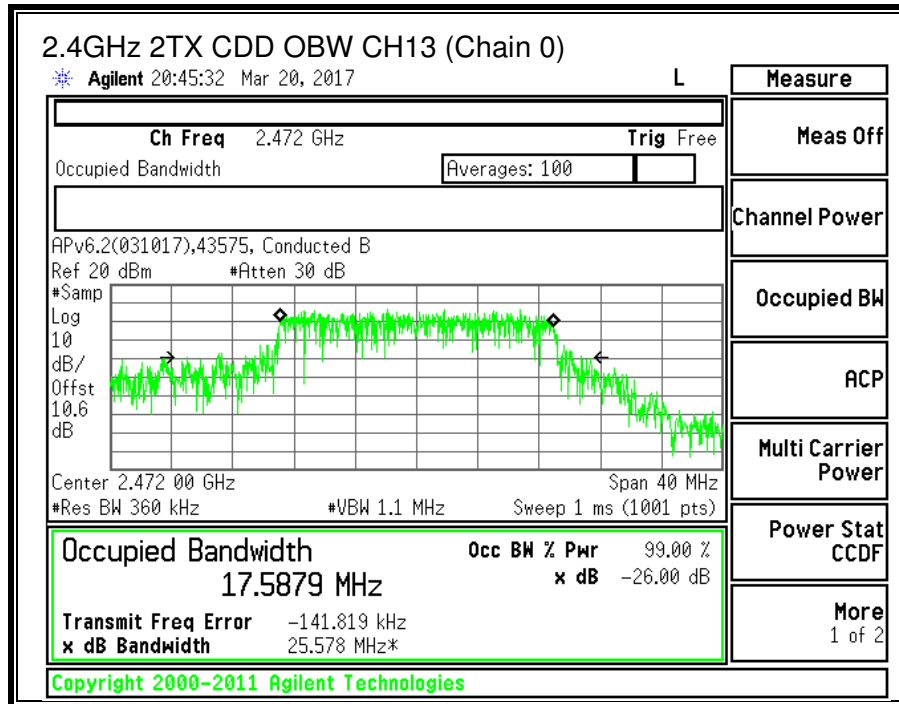

9.4.3. OUTPUT POWER

LIMITS

FCC §15.247 (b) (3)
IC RSS-247 (5.4) (4)

For systems using digital modulation in the 2400–2483.5 MHz, and 5725–5850 MHz bands: 1 Watt, based on the use of antennas with directional gains that do not exceed 6 dBi. If transmitting antennas of directional gain greater than 6 dBi are used, the conducted output power from the intentional radiator shall be reduced by the amount in dB that the directional gain of the antenna exceeds 6 dBi.

DIRECTIONAL ANTENNA GAIN

The TX chains are uncorrelated and the antenna gain is unequal among the chains. The directional gain is:

Chain 0 Antenna Gain (dBi)	Chain 1 Antenna Gain (dBi)	Uncorrelated Chains Directional Gain (dBi)
-5.20	-9.80	-6.92

TEST PROCEDURE

KDB 58074 D01 v03r05 Section 9.2.3.2

RESULTS

ID:	50818	Date:	03/23/2017
------------	-------	--------------	------------

Limits

Channel	Frequency (MHz)	Directional Gain (dBi)	FCC Power Limit (dBm)	IC Power Limit (dBm)	IC EIRP Limit (dBm)	Max Power (dBm)
CH1	2412	-6.92	30.00	30	36	30.00
CH2	2417	-6.92	30.00	30	36	30.00
CH3	2422	-6.92	30.00	30	36	30.00
CH6	2437	-6.92	30.00	30	36	30.00
CH10	2457	-6.92	30.00	30	36	30.00
CH11	2462	-6.92	30.00	30	36	30.00
CH12	2467	-6.92	30.00	30	36	30.00
CH13	2472	-6.92	30.00	30	36	30.00

Results

Channel	Frequency (MHz)	Chain 0 Meas Power (dBm)	Chain 1 Meas Power (dBm)	Total Corr'd Power (dBm)	Power Limit (dBm)	Margin (dB)
CH1	2412	8.93	10.88	13.02	30.00	-16.98
CH2	2417	9.03	10.74	12.98	30.00	-17.02
CH3	2422	17.94	19.06	21.55	30.00	-8.45
CH6	2437	17.99	18.52	21.27	30.00	-8.73
CH10	2457	18.05	17.89	20.98	30.00	-9.02
CH11	2462	14.85	14.65	17.76	30.00	-12.24
CH12	2467	8.56	8.65	11.62	30.00	-18.38
CH13	2472	3.05	3.23	6.15	30.00	-23.85

9.4.4. POWER SPECTRAL DENSITY

LIMITS

FCC §15.247 (e)
 IC RSS-247 (5.2) (2)

For digitally modulated systems, the power spectral density conducted from the intentional radiator to the antenna shall not be greater than 8 dBm in any 3 KHz band during any time interval of continuous transmissions.

RESULTS

Duty Cycle CF (dB)	0.11	Included in Calculations of Corr'd PSD
--------------------	------	--

PSD Results

Channel	Frequency (MHz)	Chain 0 Meas (dBm)	Chain 1 Meas (dBm)	Total Corr'd PSD (dBm)	Limit (dBm)	Margin (dB)
CH1	2412	-15.817	-14.400	-11.93	8.0	-19.9
CH2	2417	-15.602	-14.336	-11.80	8.0	-19.8
CH3	2422	-6.810	-6.389	-3.47	8.0	-11.5
CH6	2437	-5.904	-6.163	-2.91	8.0	-10.9
CH10	2457	-6.885	-7.665	-4.14	8.0	-12.1
CH11	2462	-7.008	-7.021	-3.89	8.0	-11.9
CH12	2467	-16.015	-15.937	-12.86	8.0	-20.9
CH13	2472	-21.807	-21.174	-18.36	8.0	-26.4

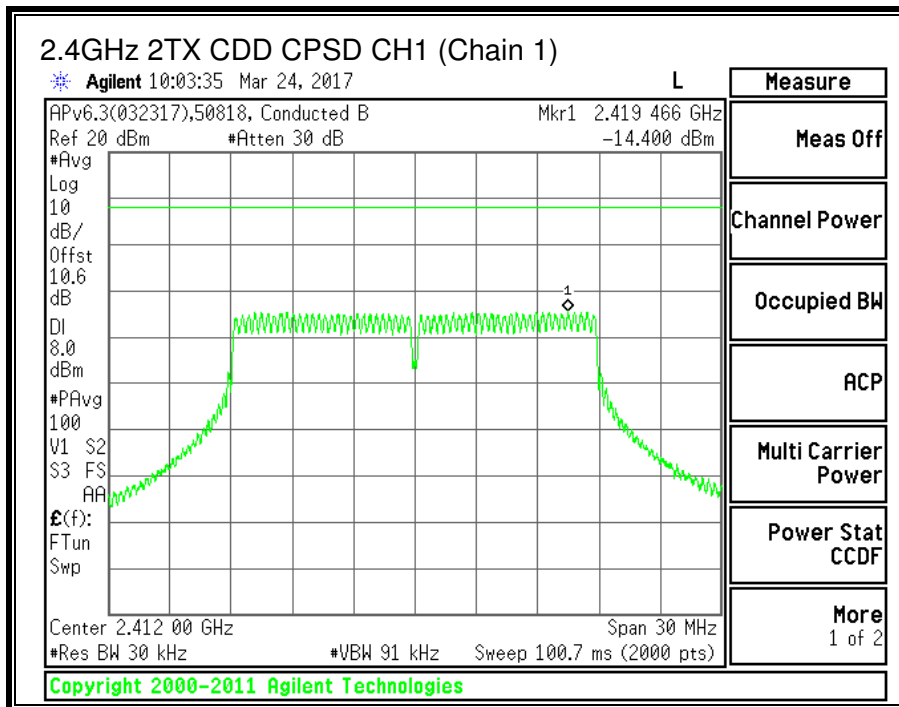
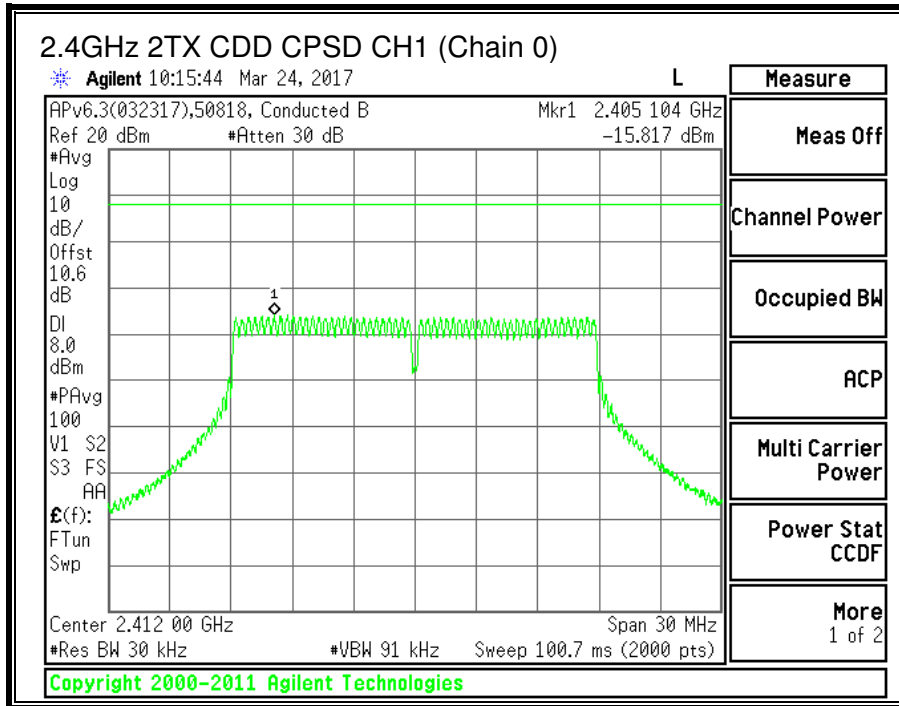

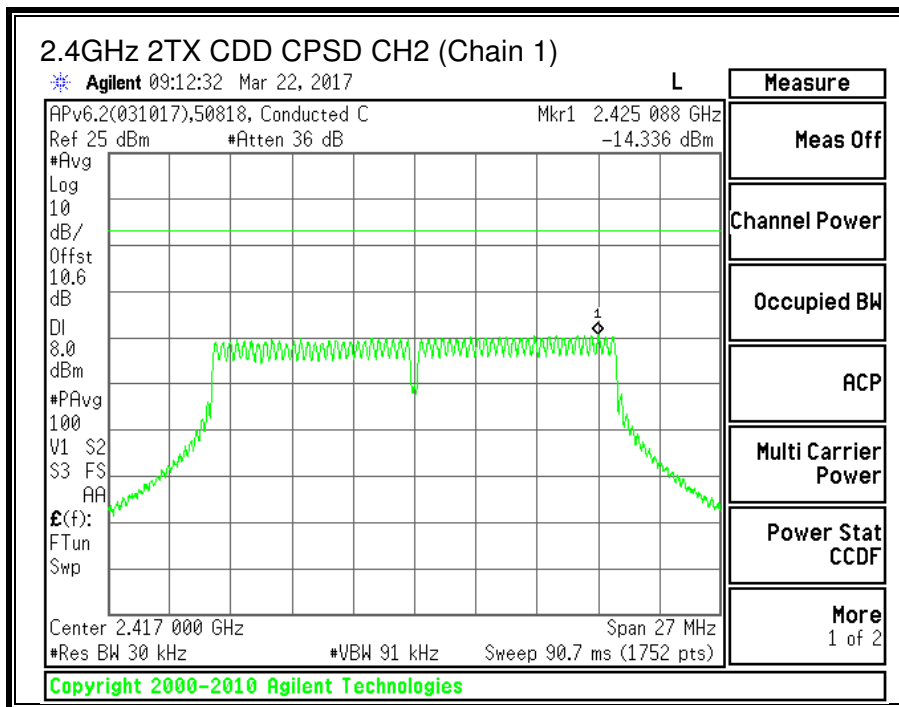
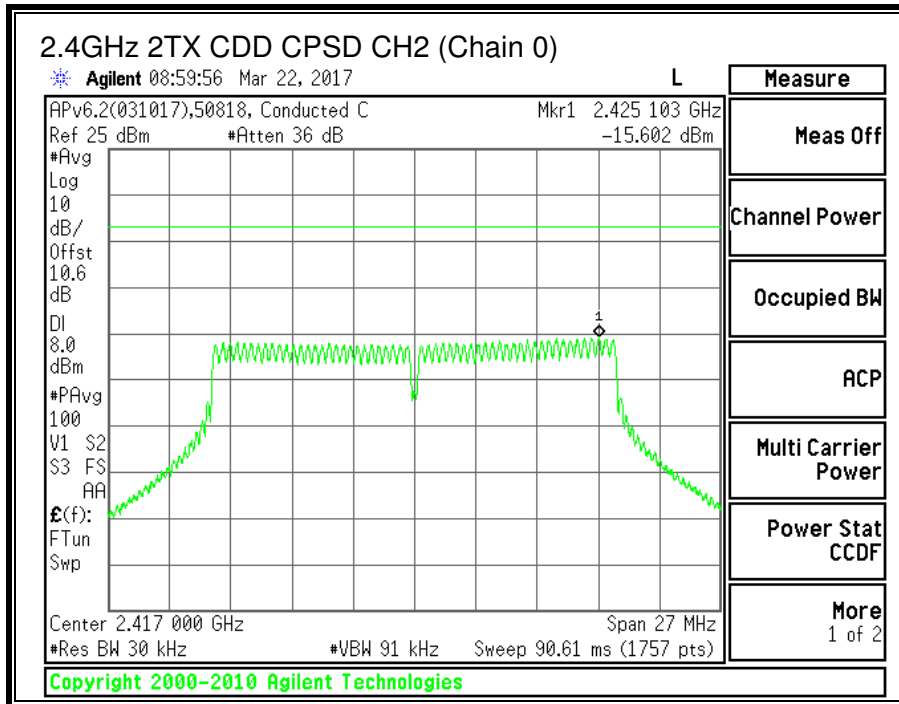

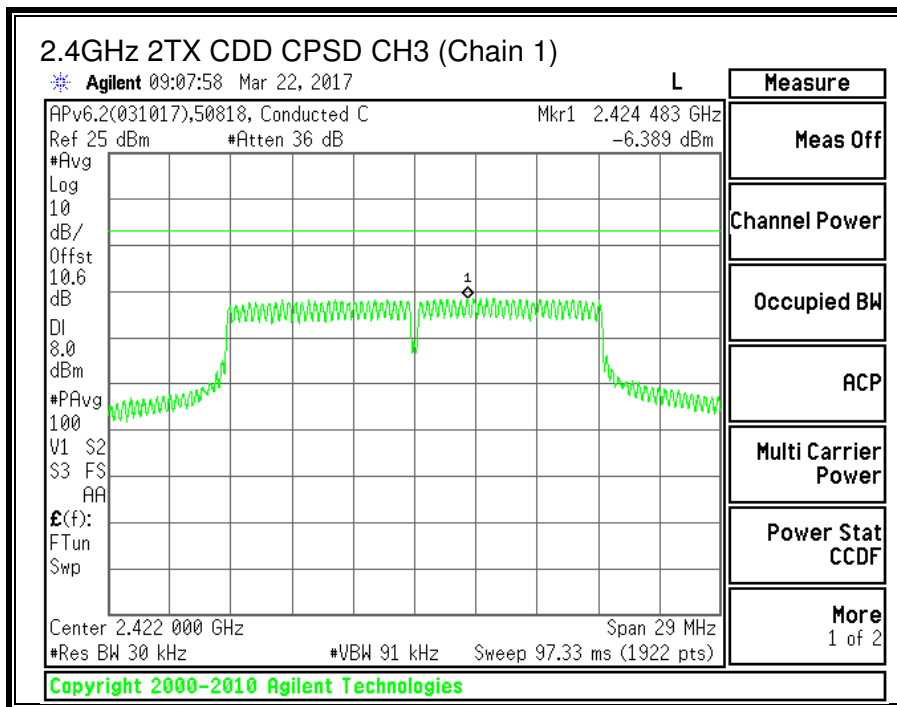
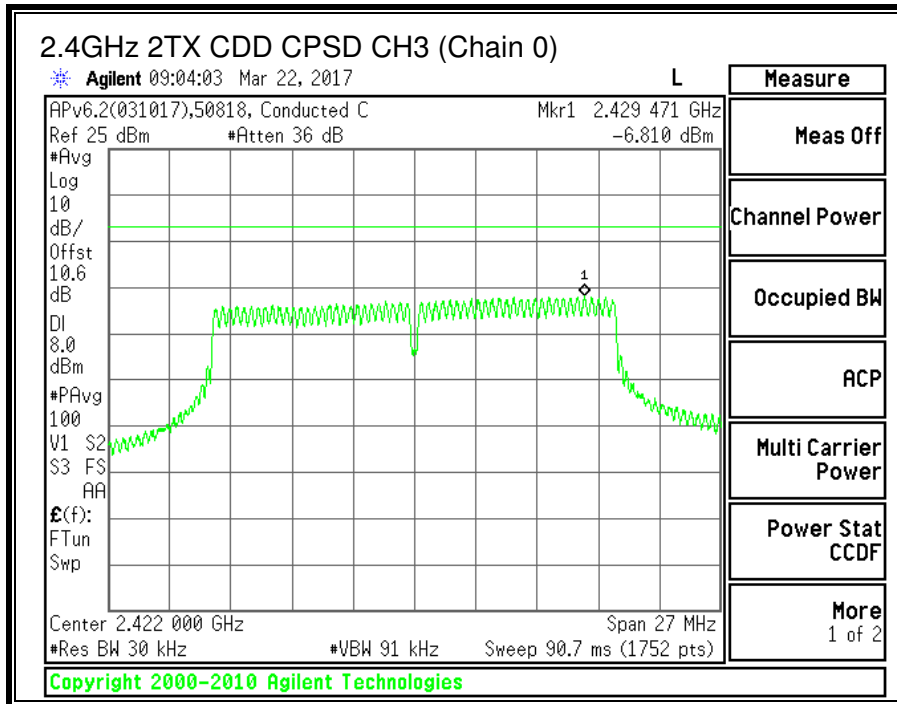

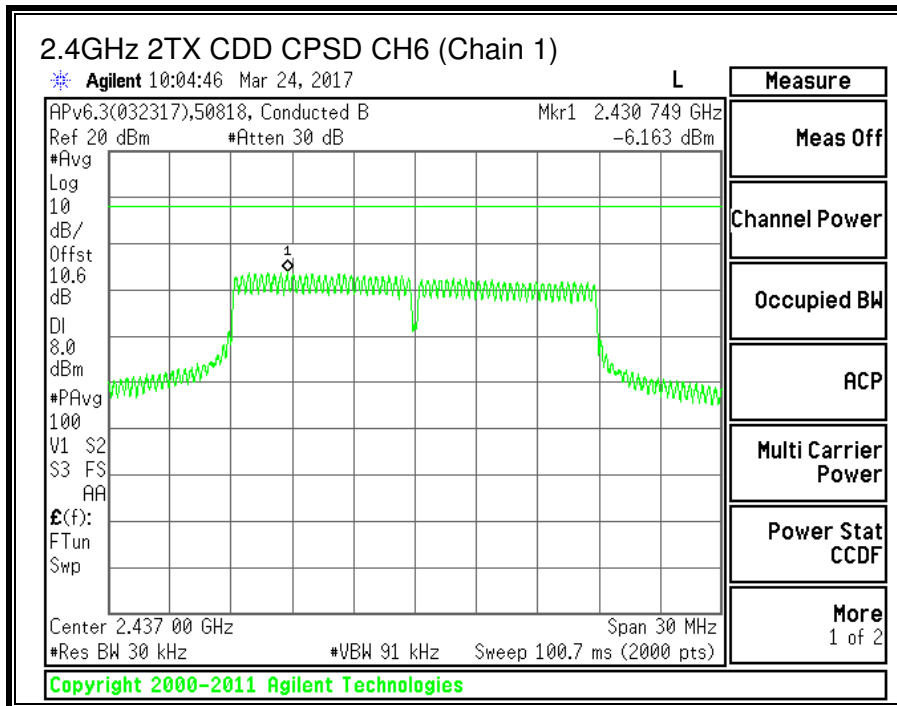
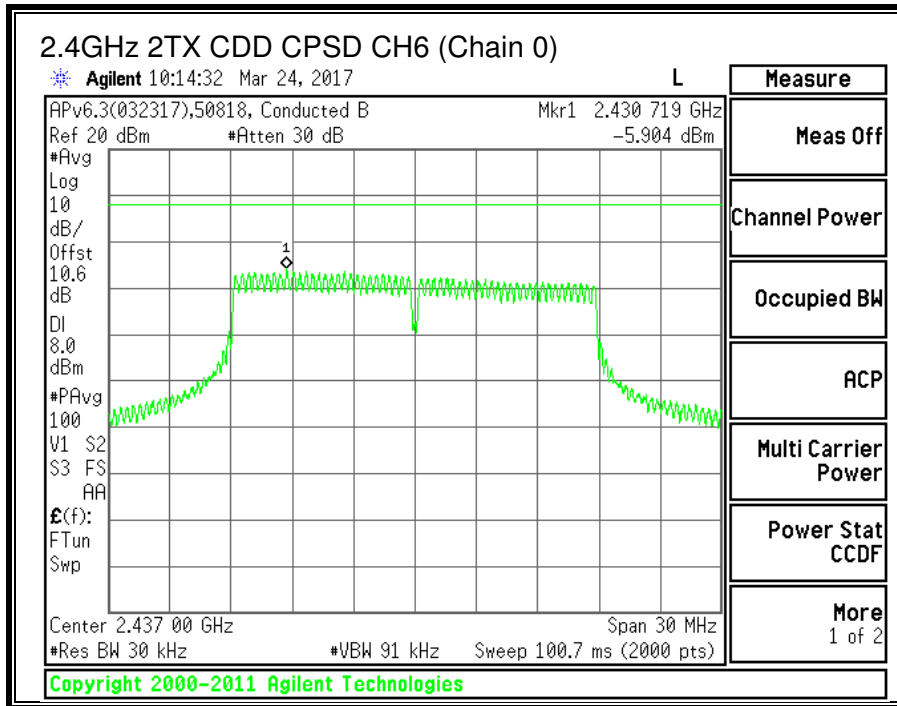

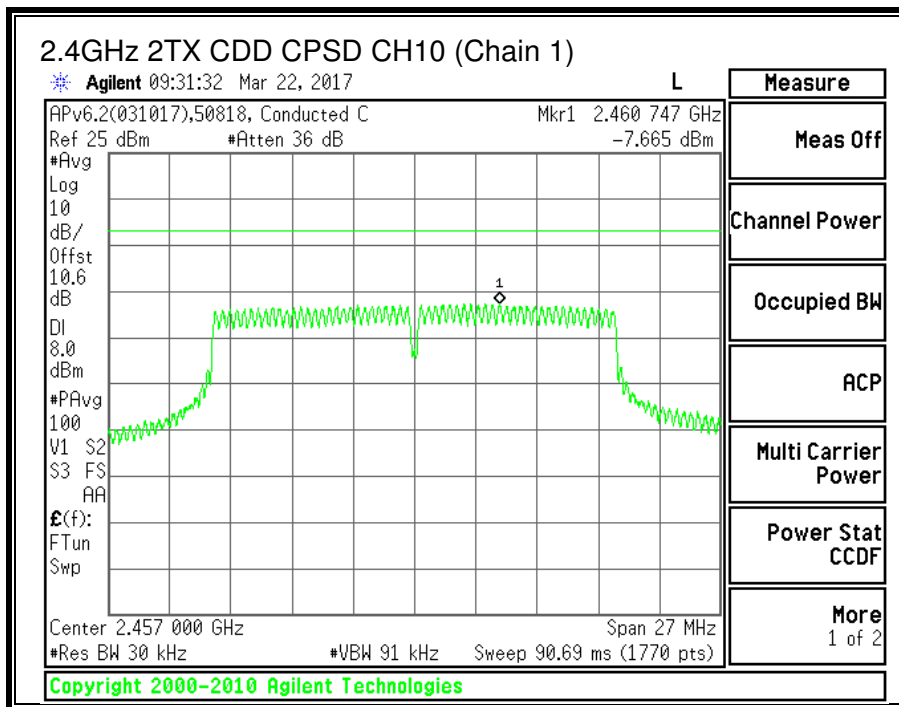
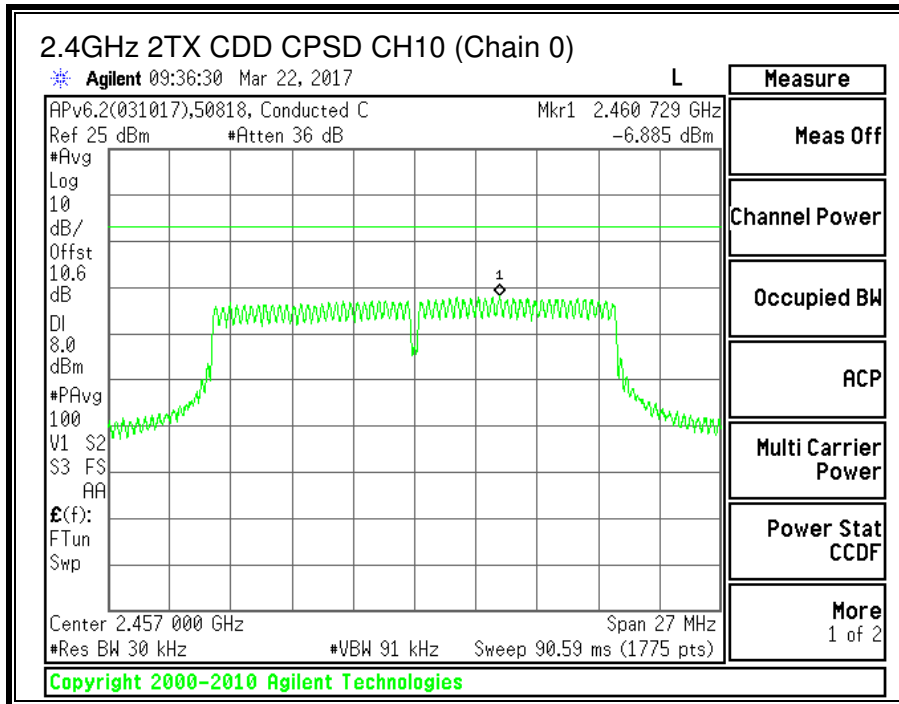

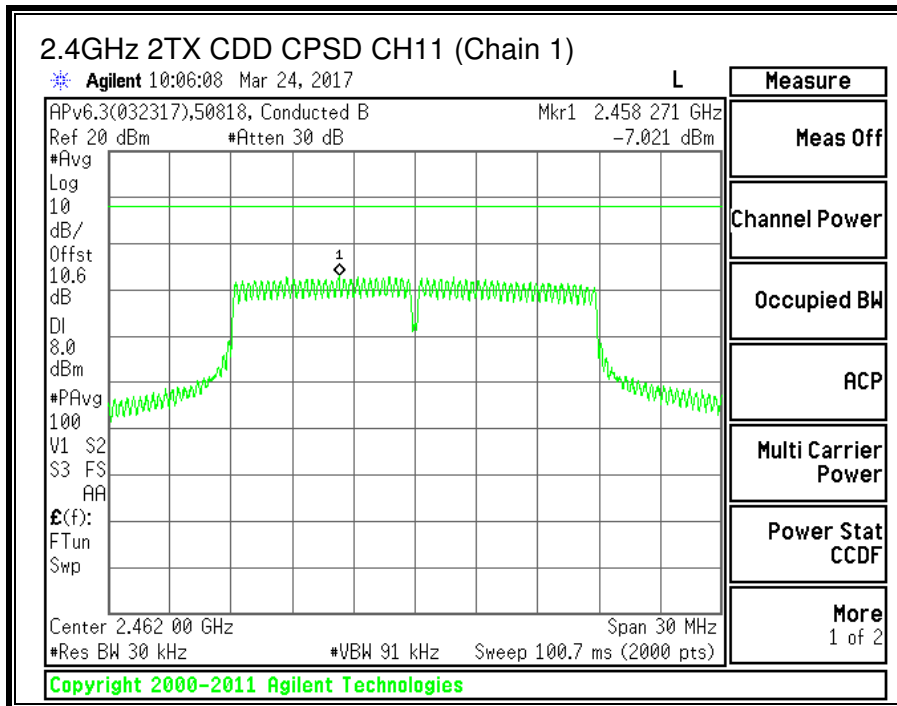
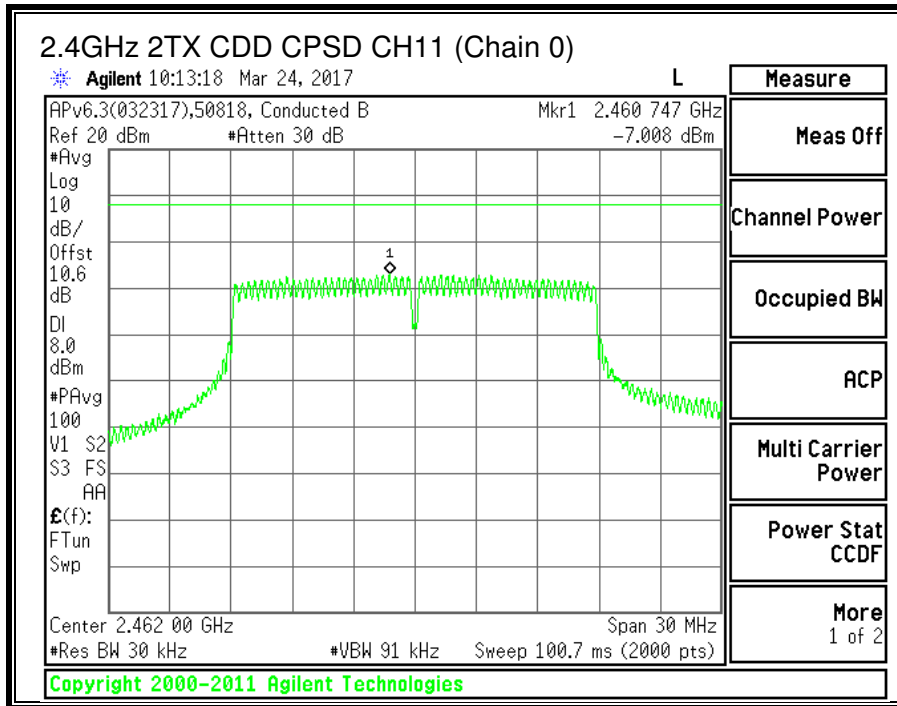

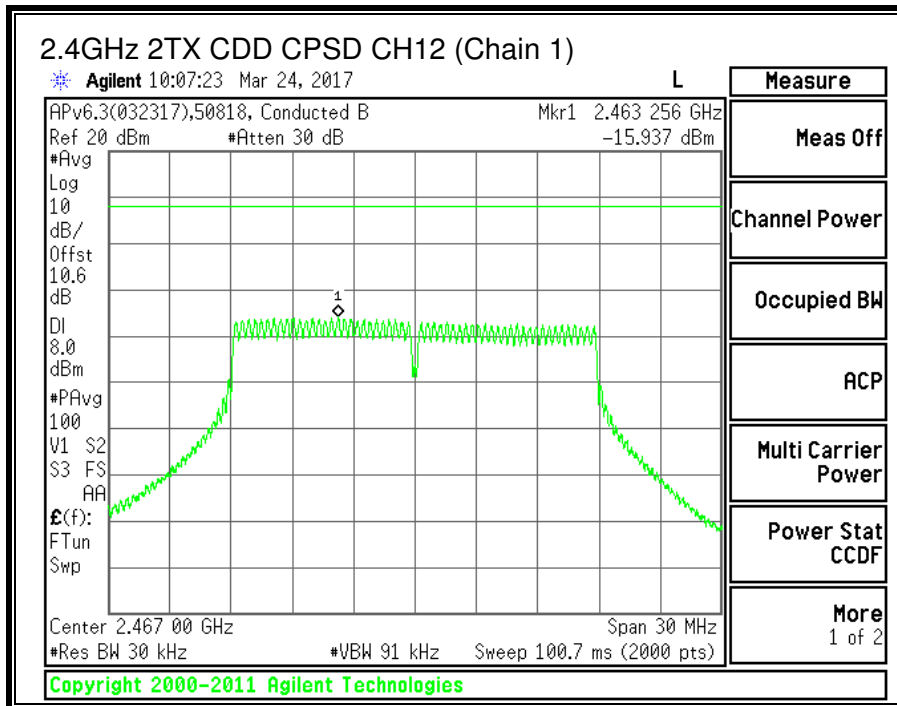
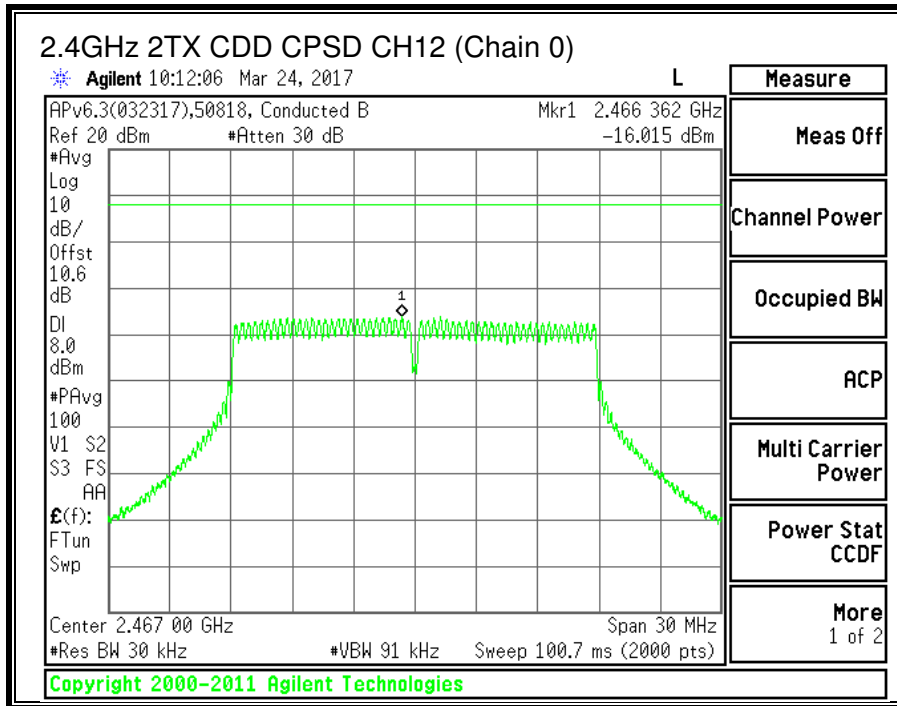

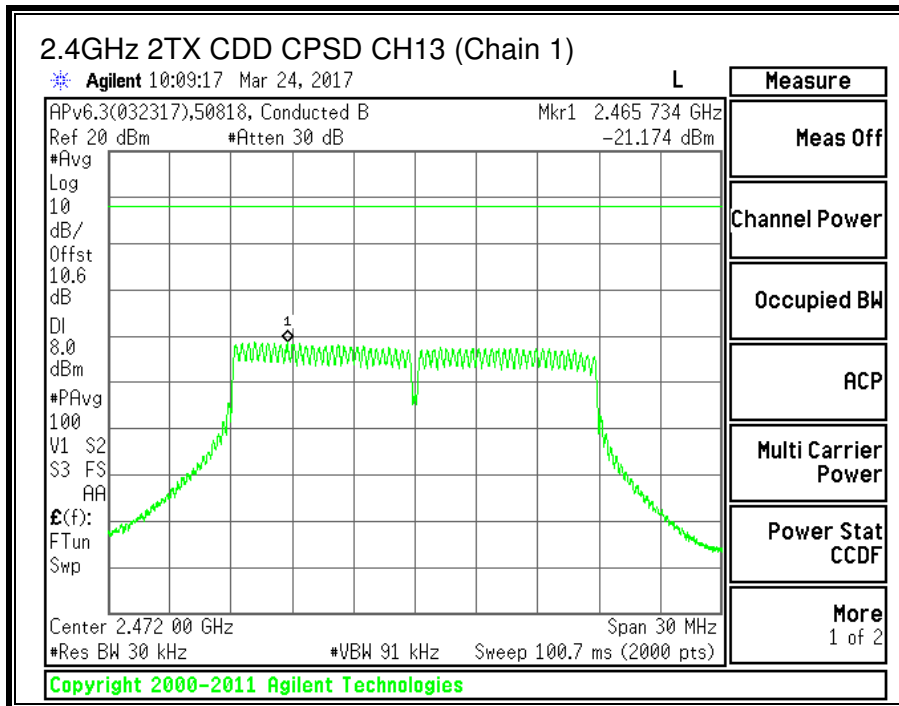
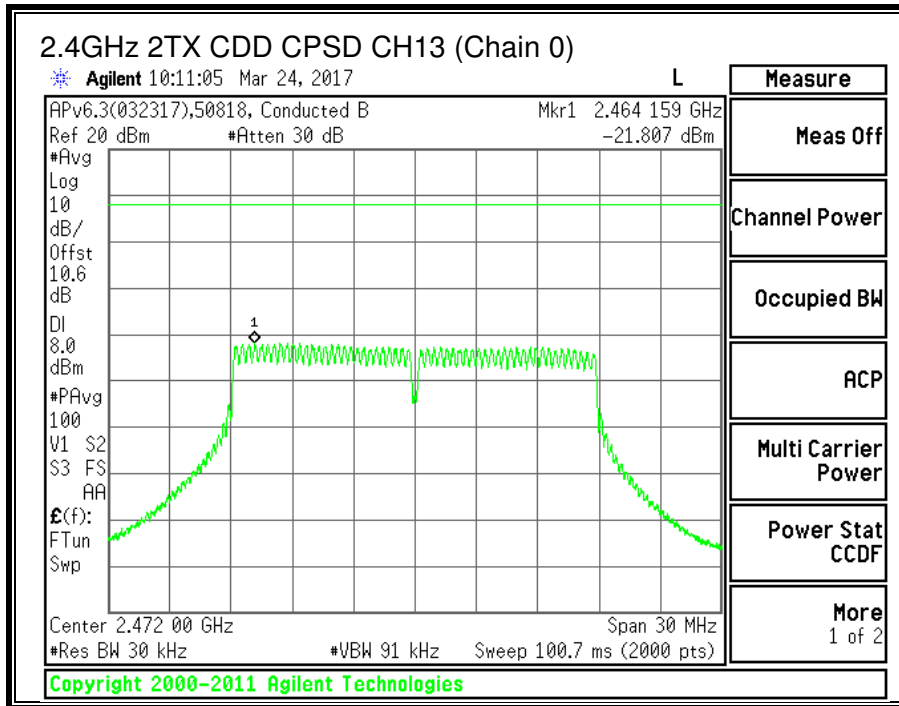

9.4.5. CONDUCTED BANDEDGE AND SPURIOUS EMISSIONS

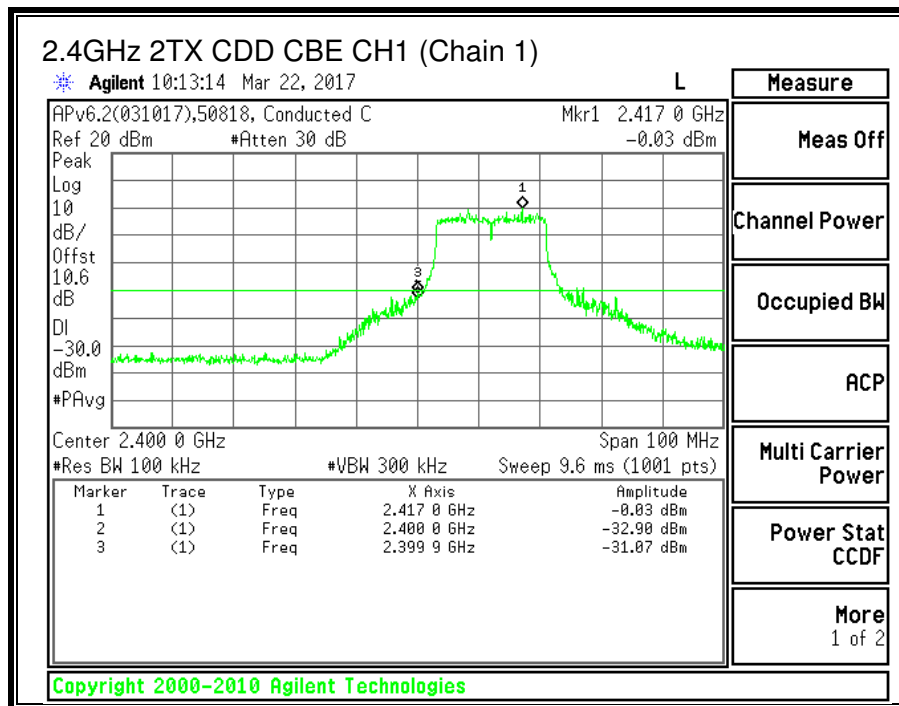
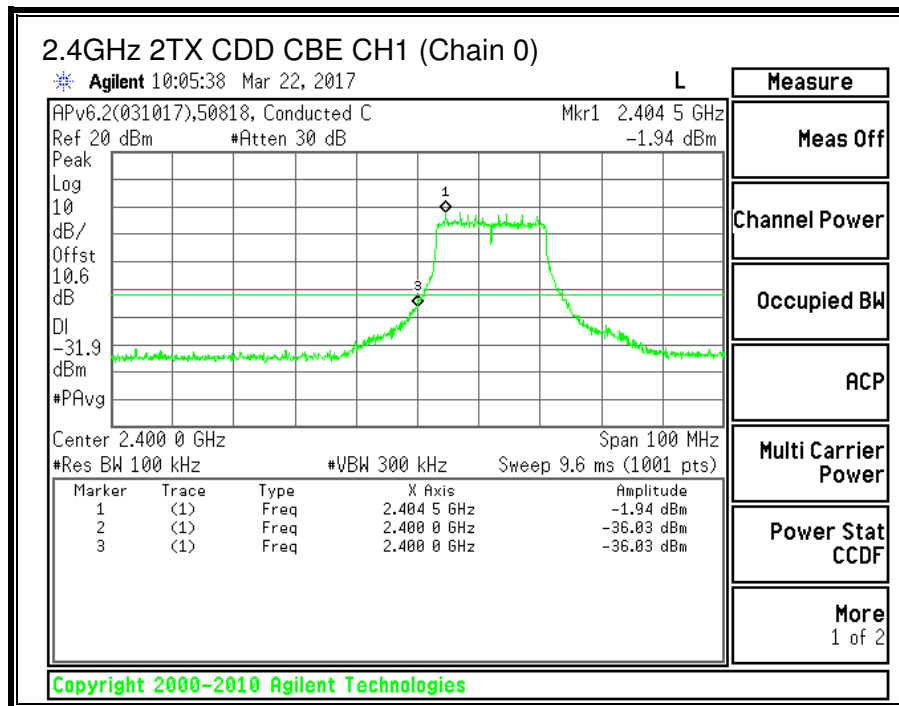

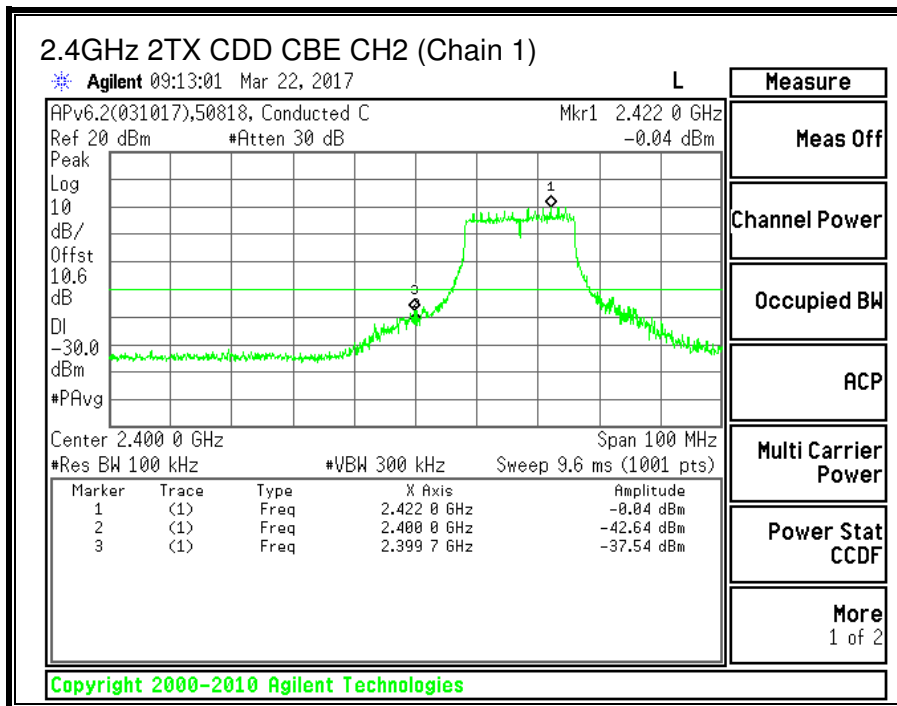
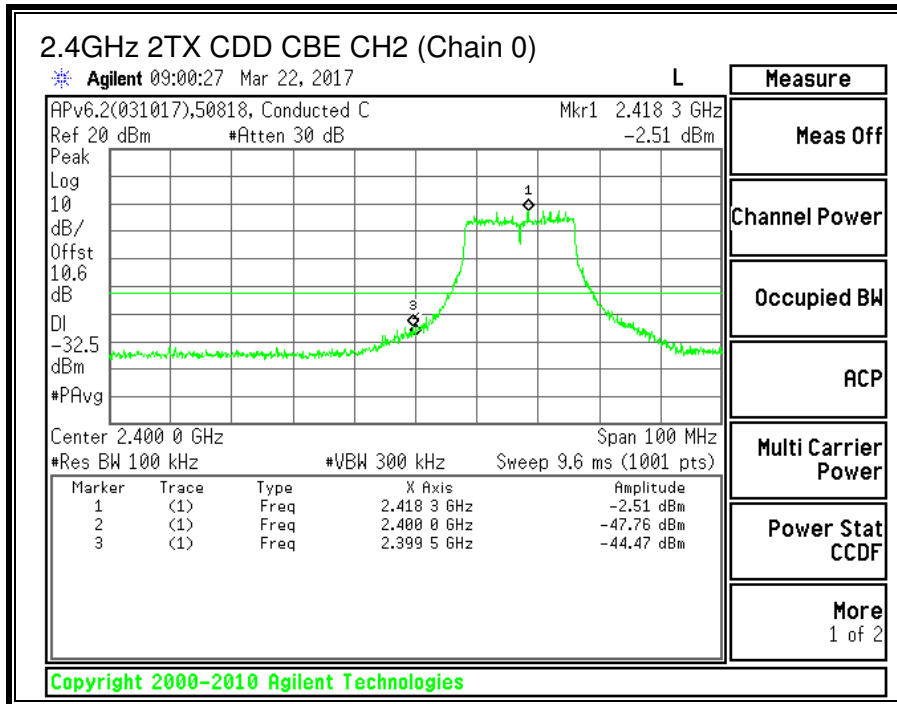

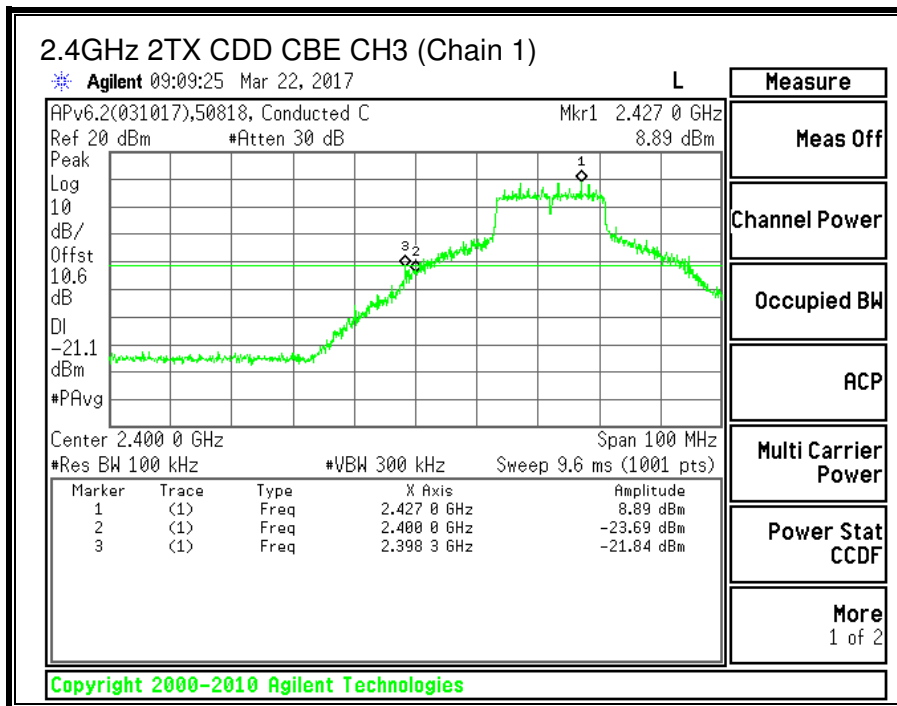
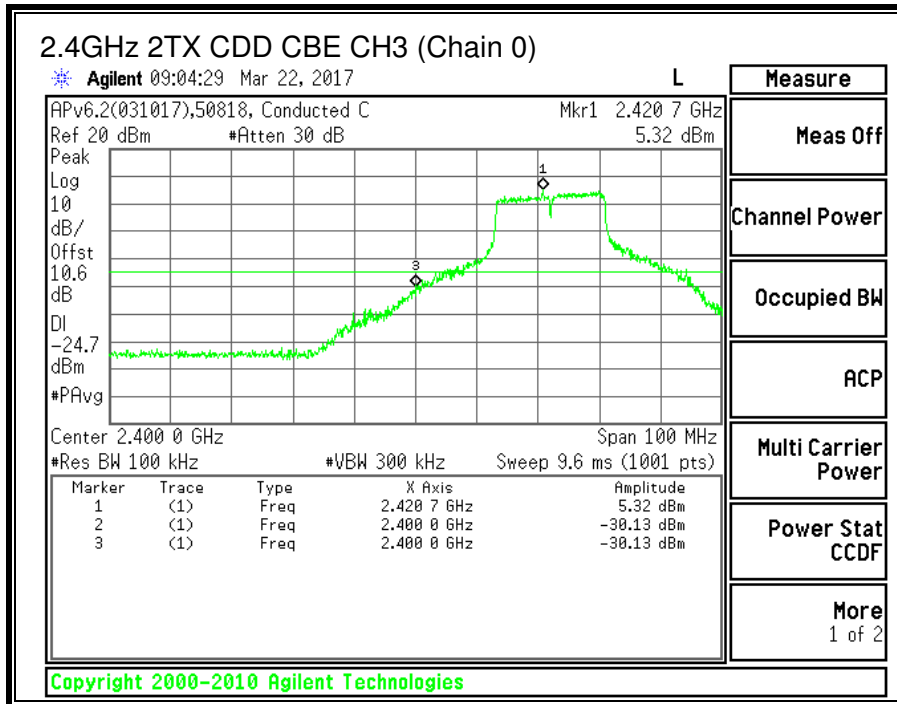

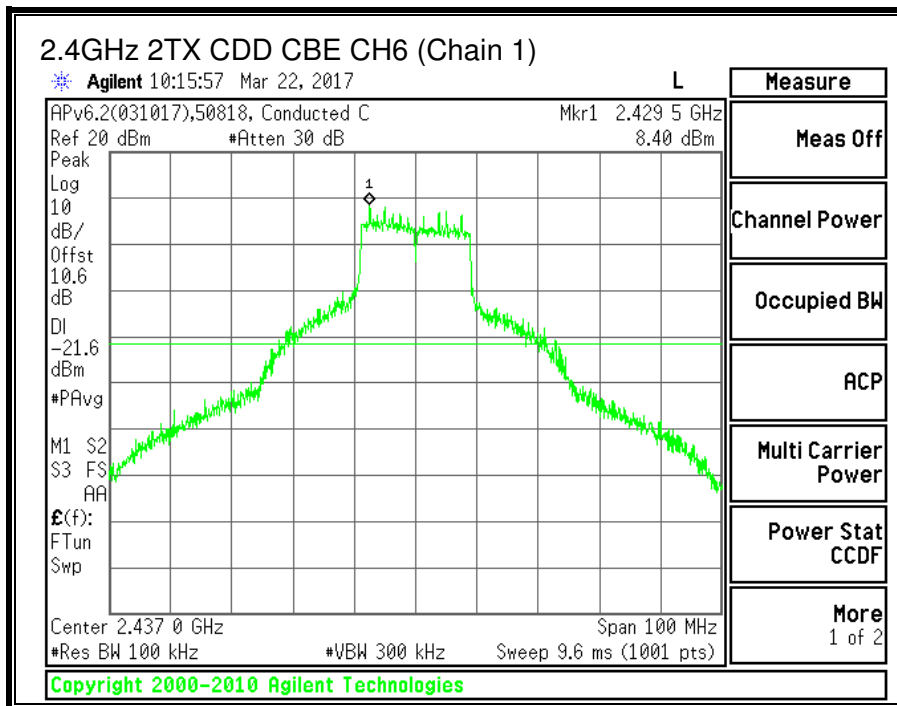
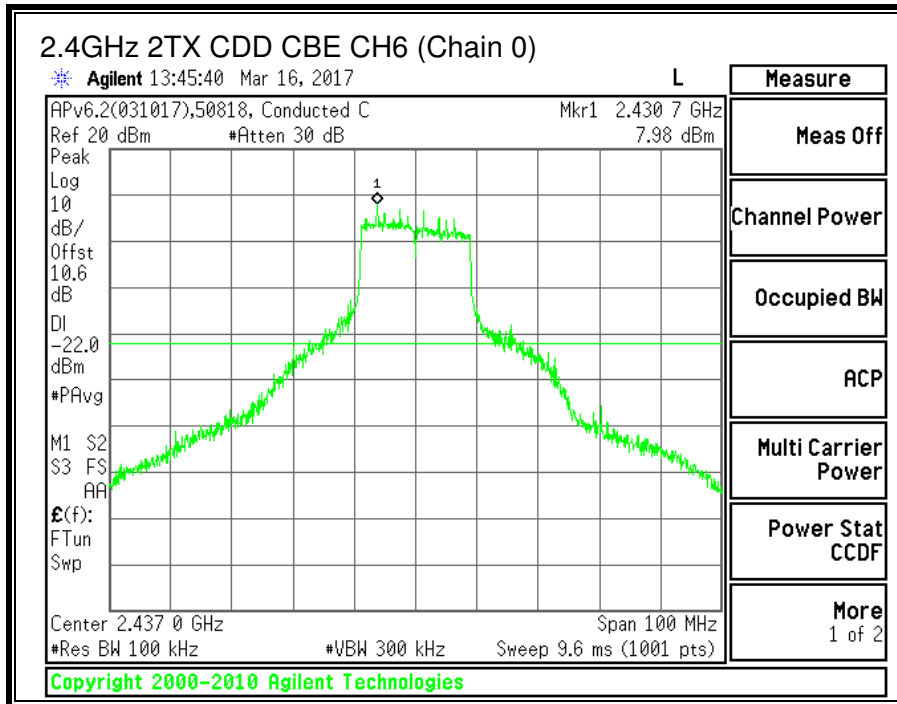

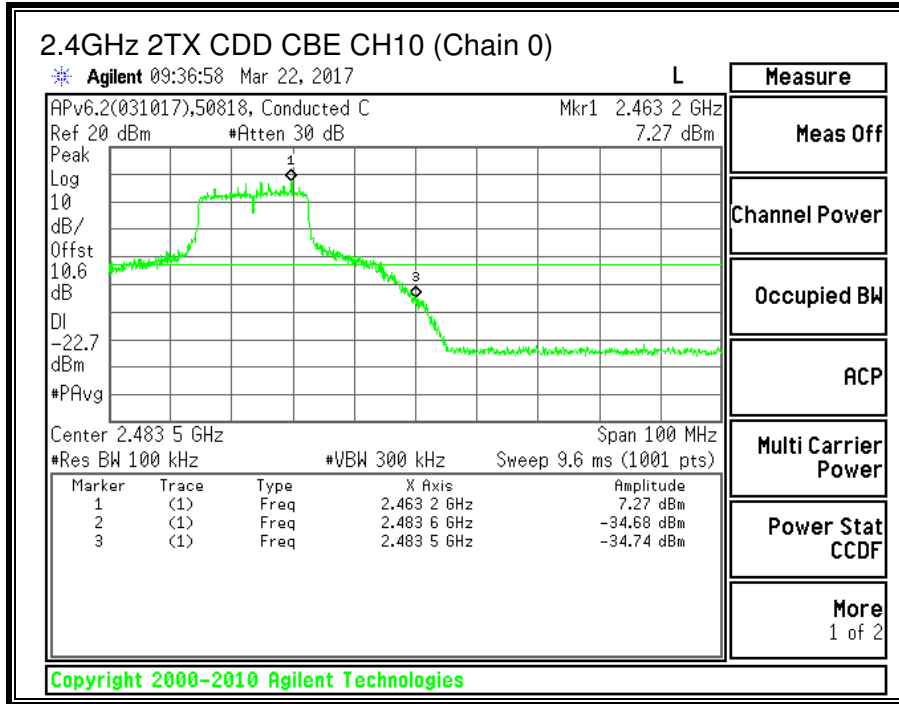

- Measure
- Meas Off
- Channel Power
- Occupied BW
- ACP
- Multi Carrier Power
- Power Stat CCDF
- More 1 of 2

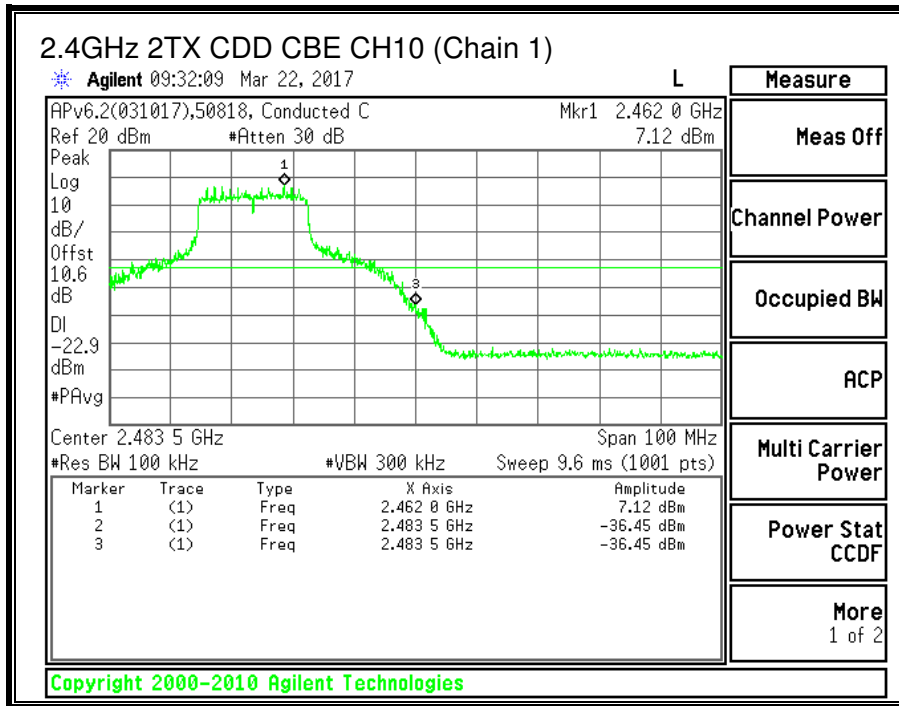

- Measure
- Meas Off
- Channel Power
- Occupied BW
- ACP
- Multi Carrier Power
- Power Stat CCDF
- More 1 of 2

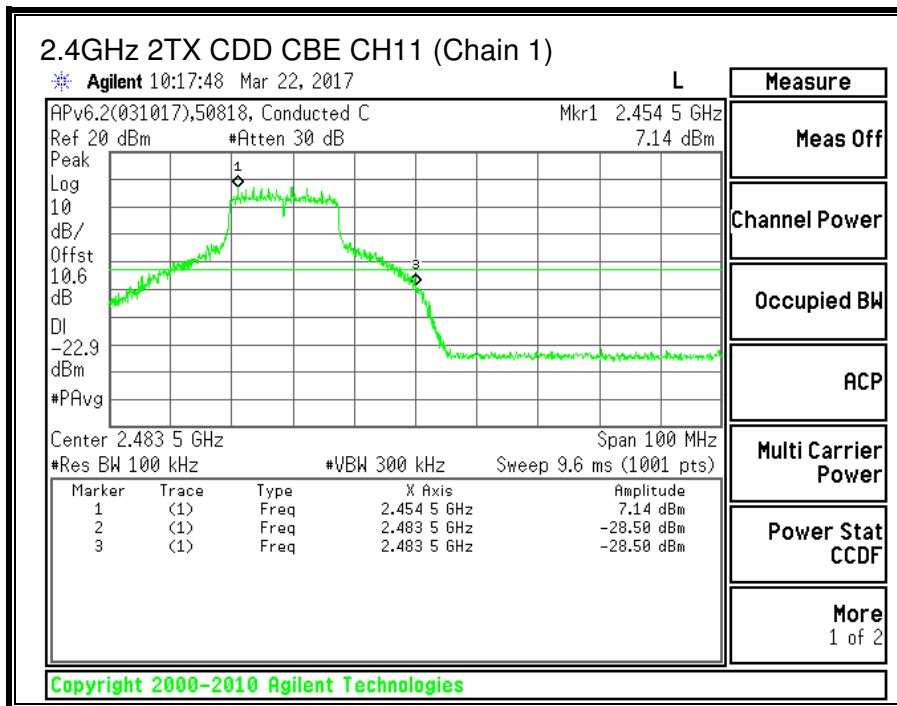
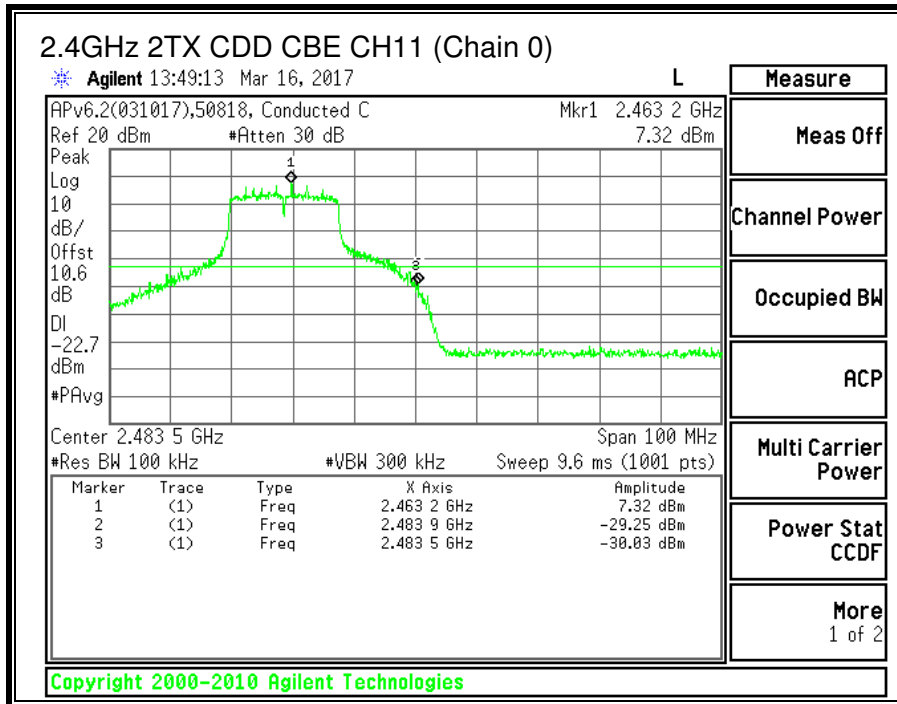

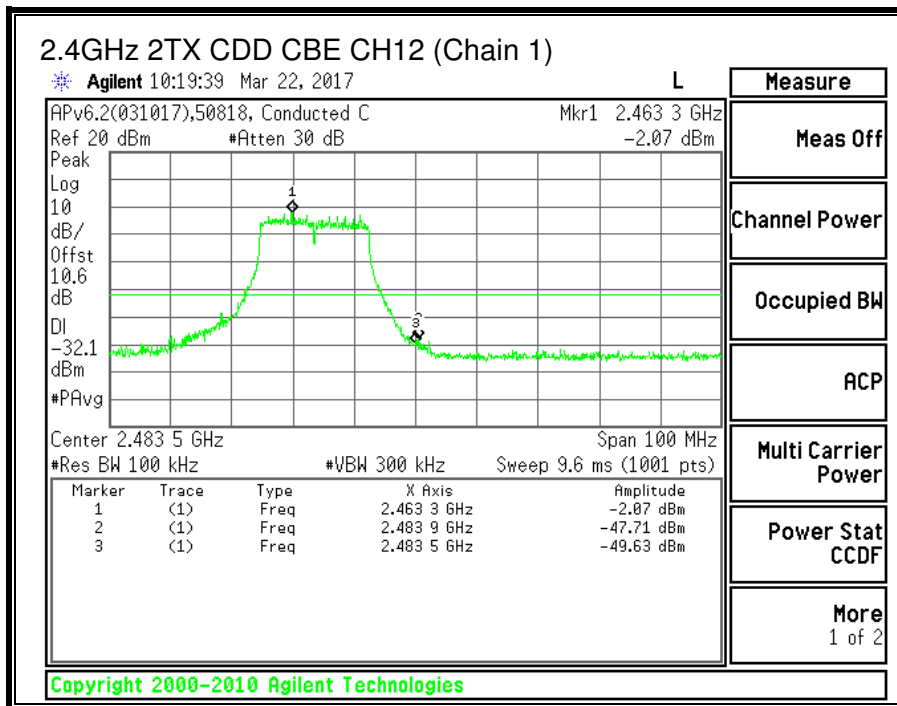
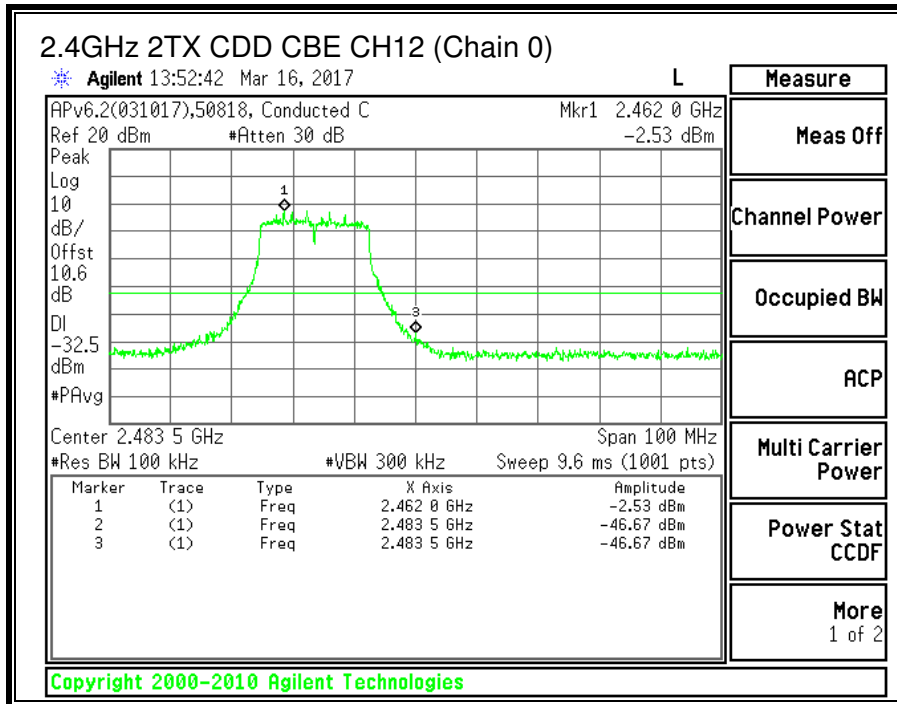

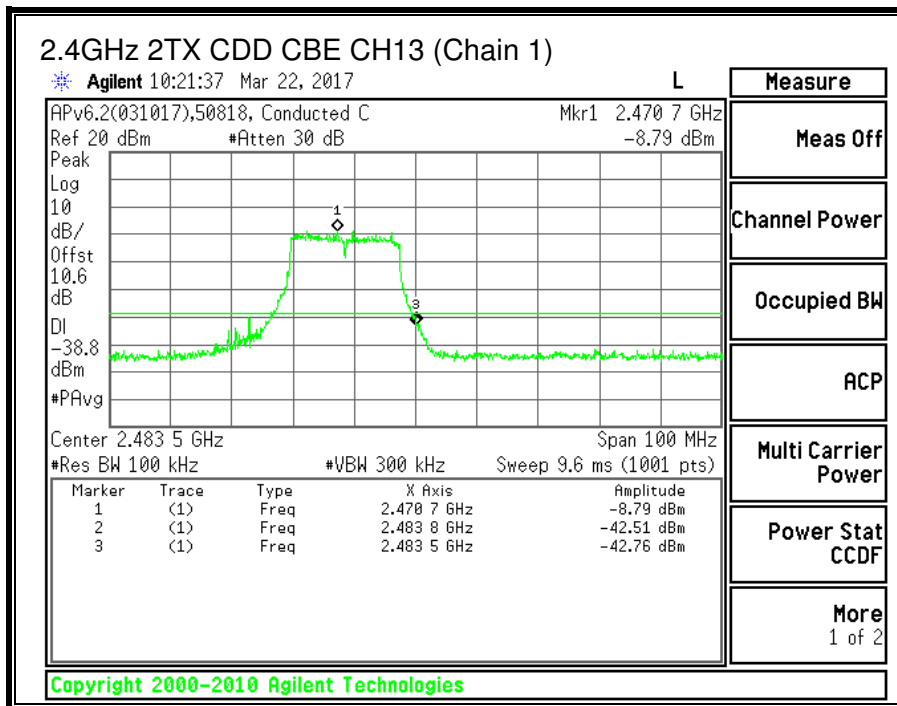
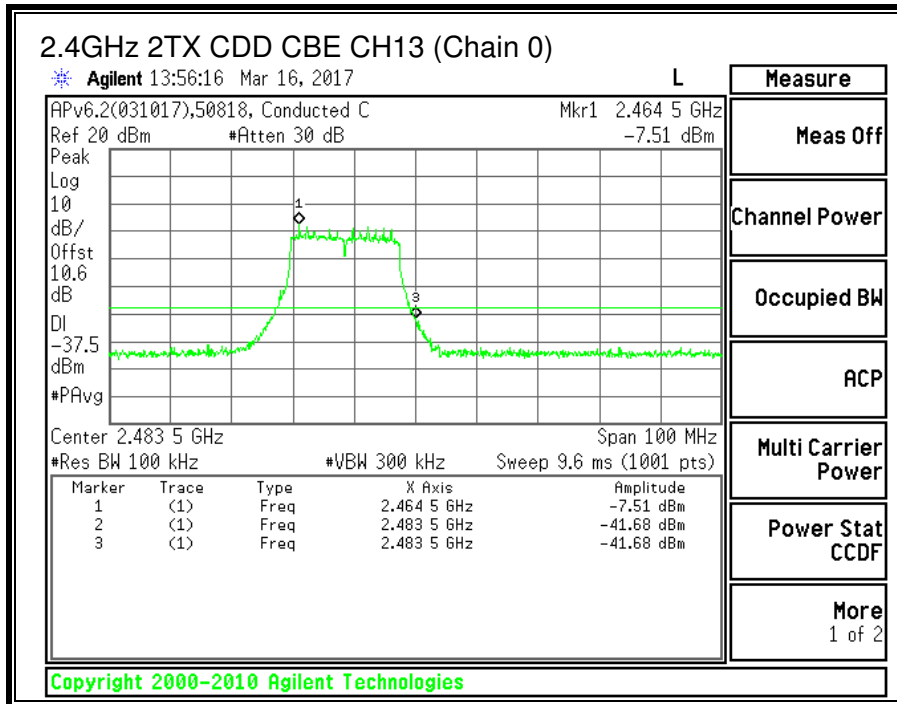

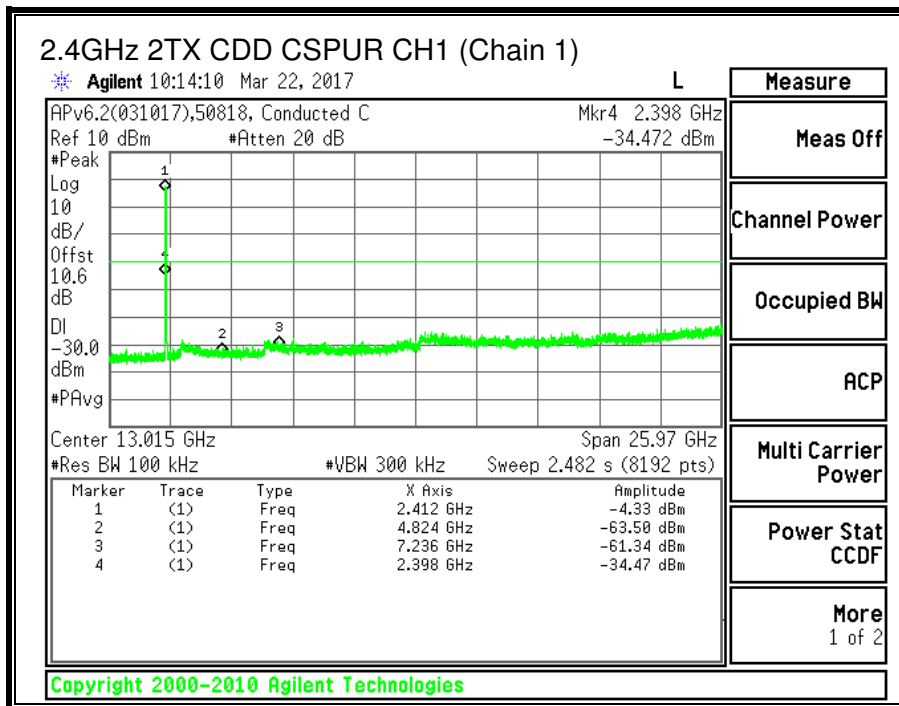
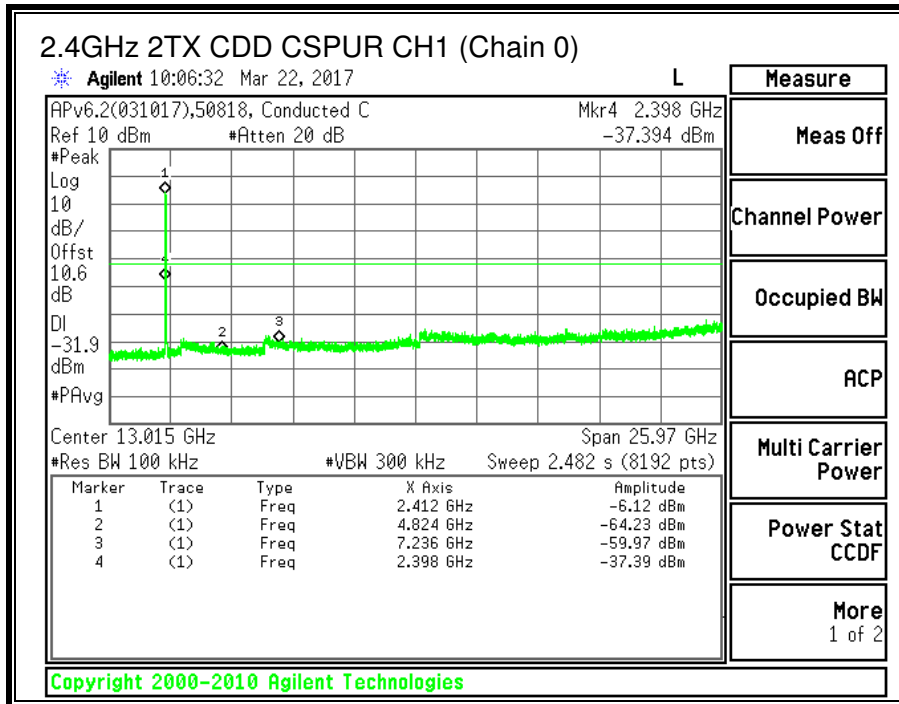

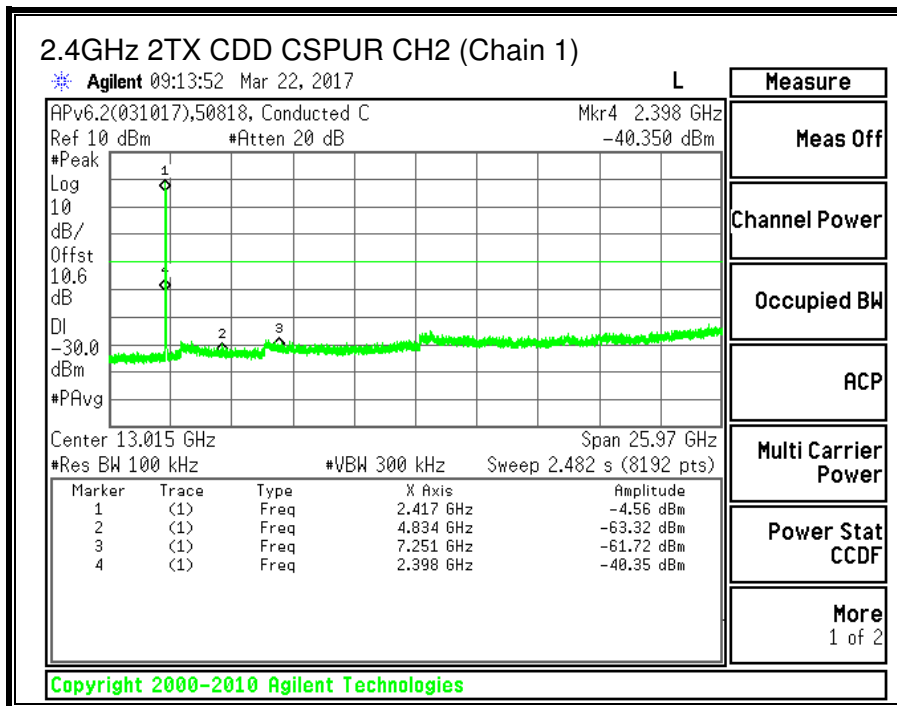
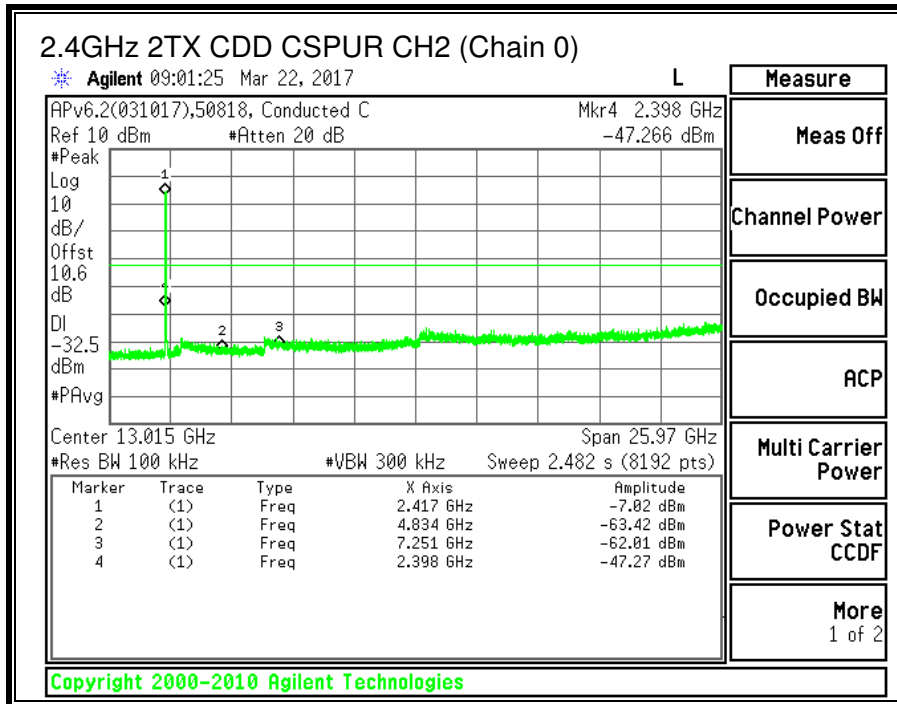

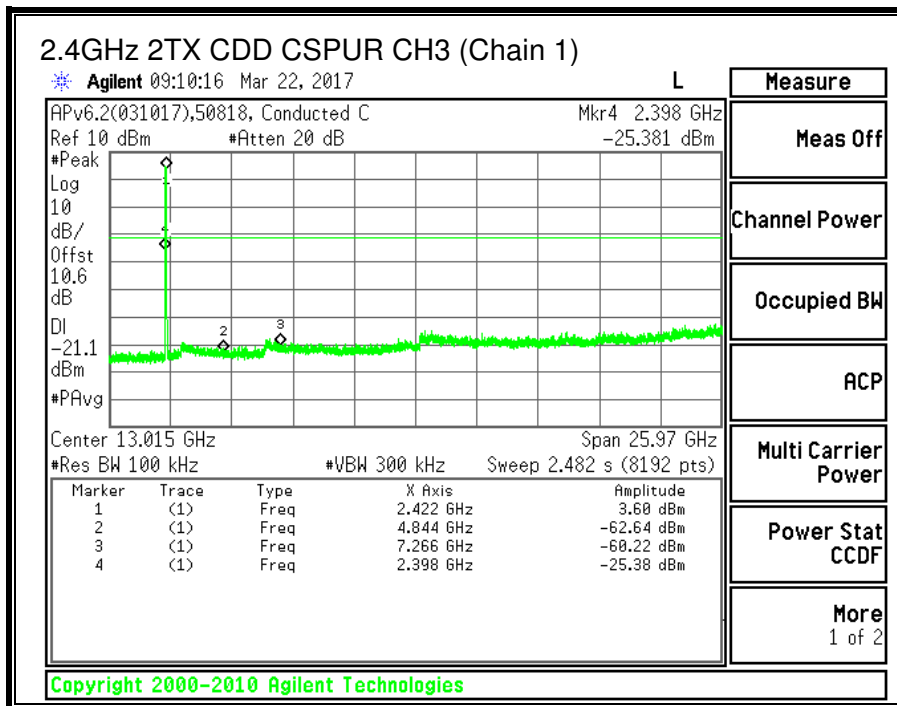
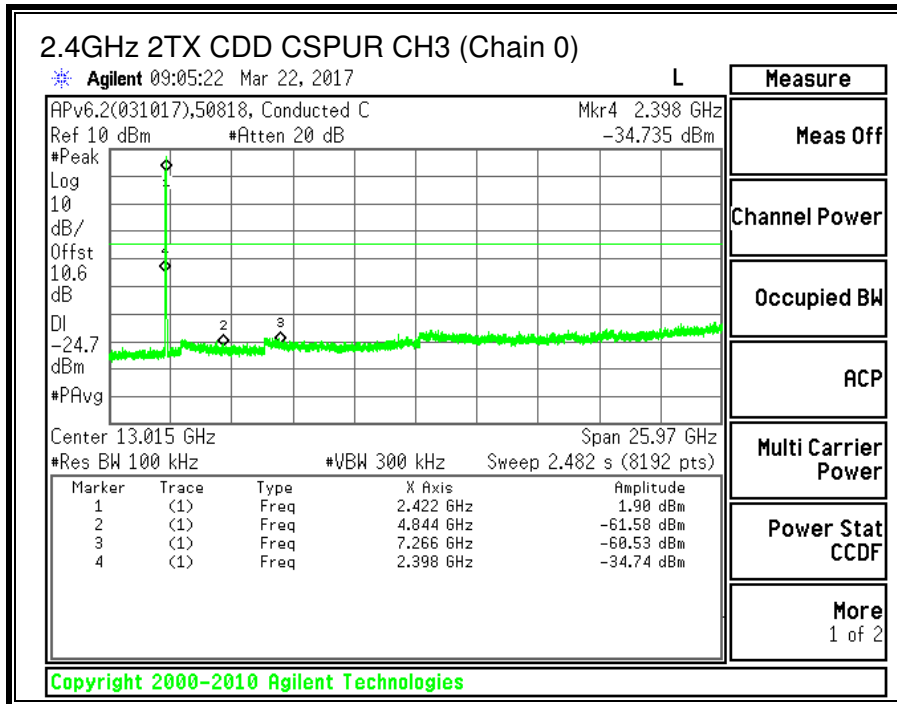

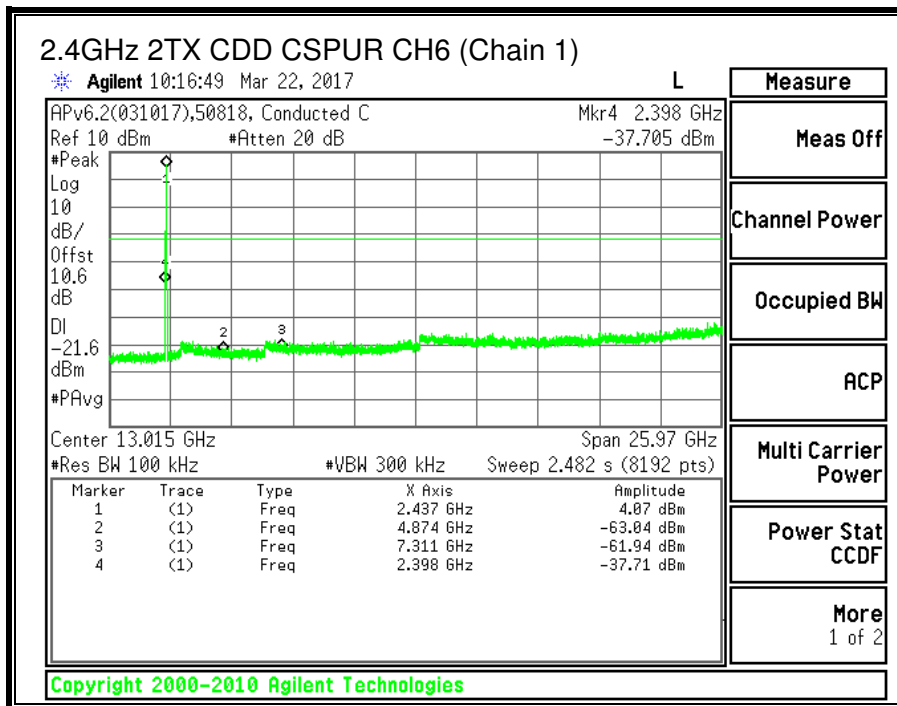
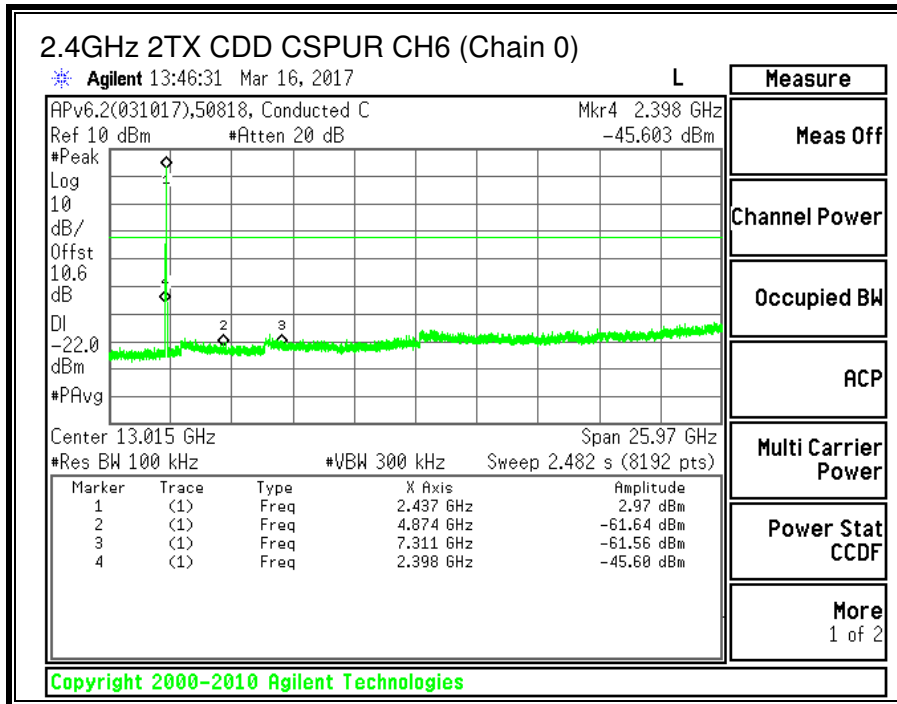

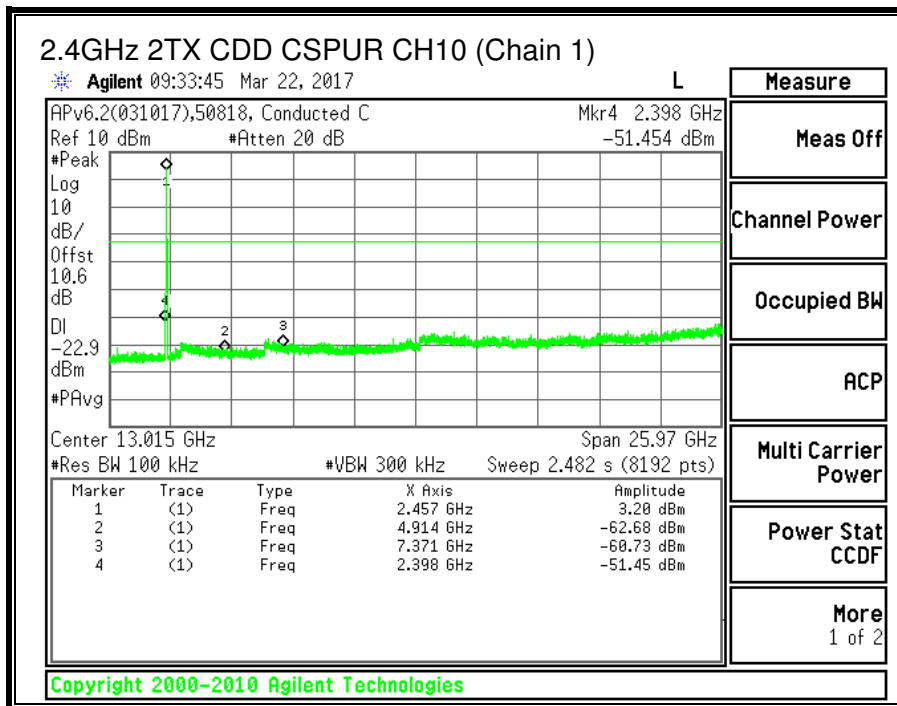
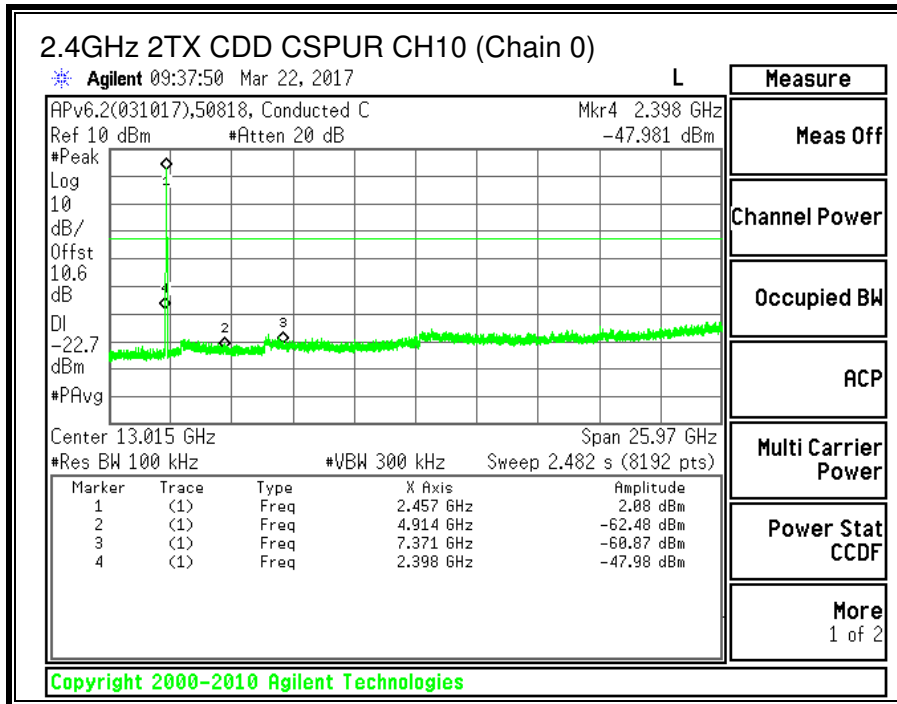

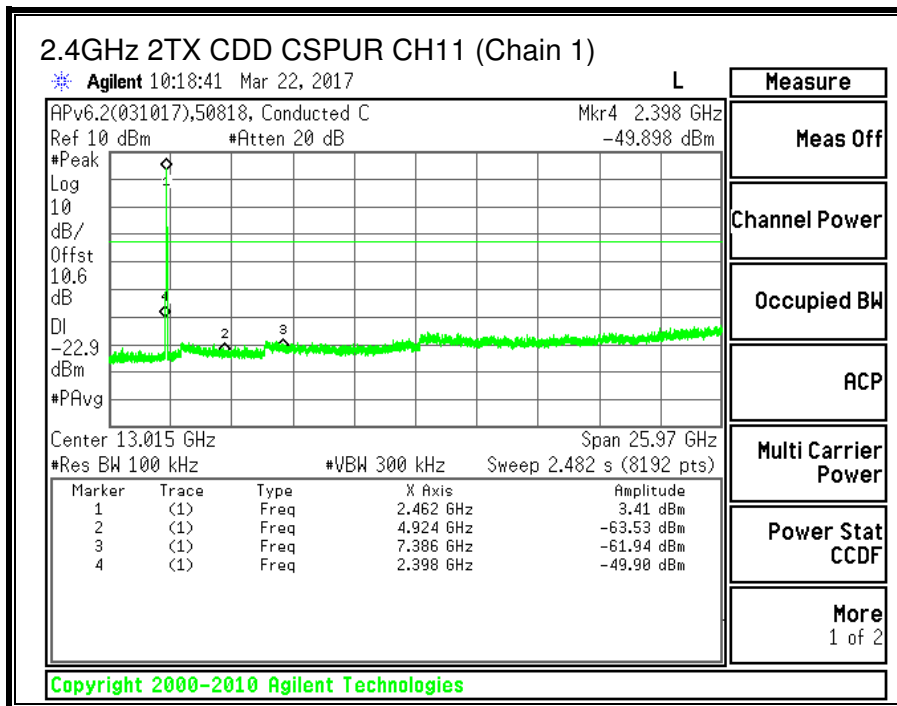
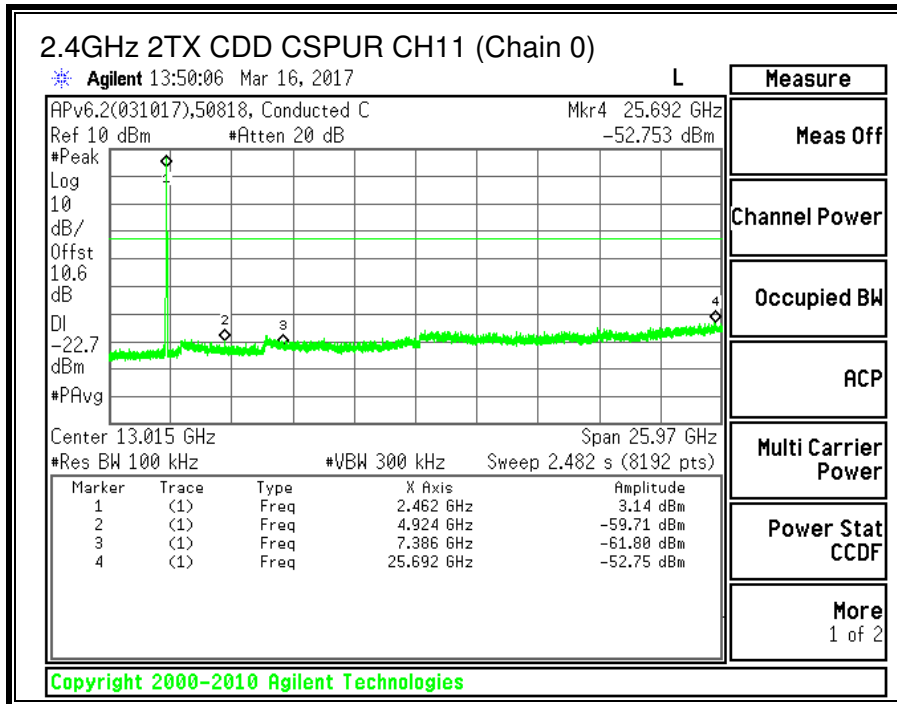

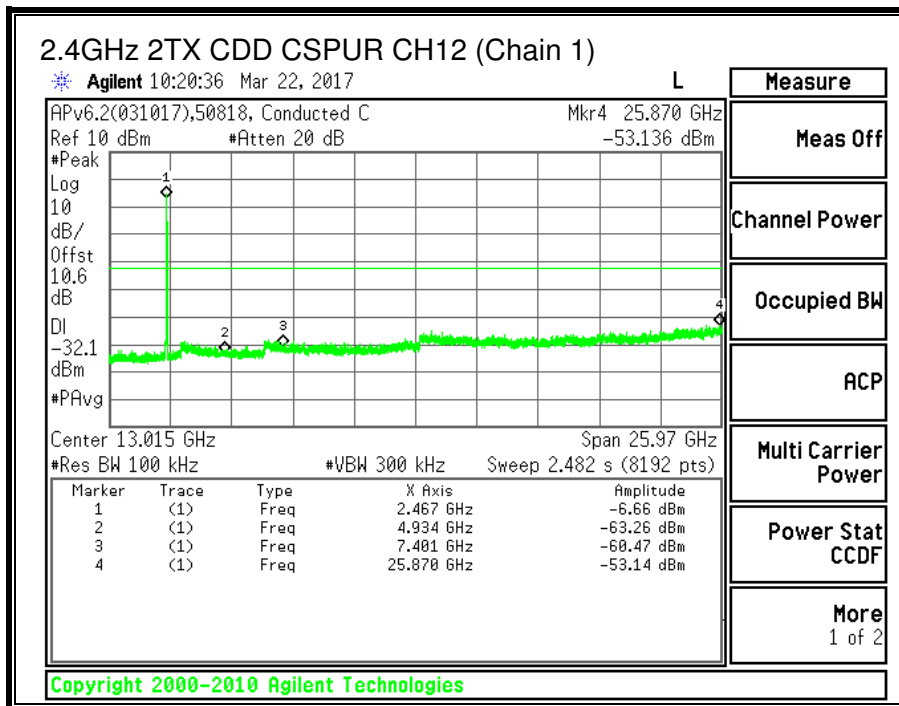
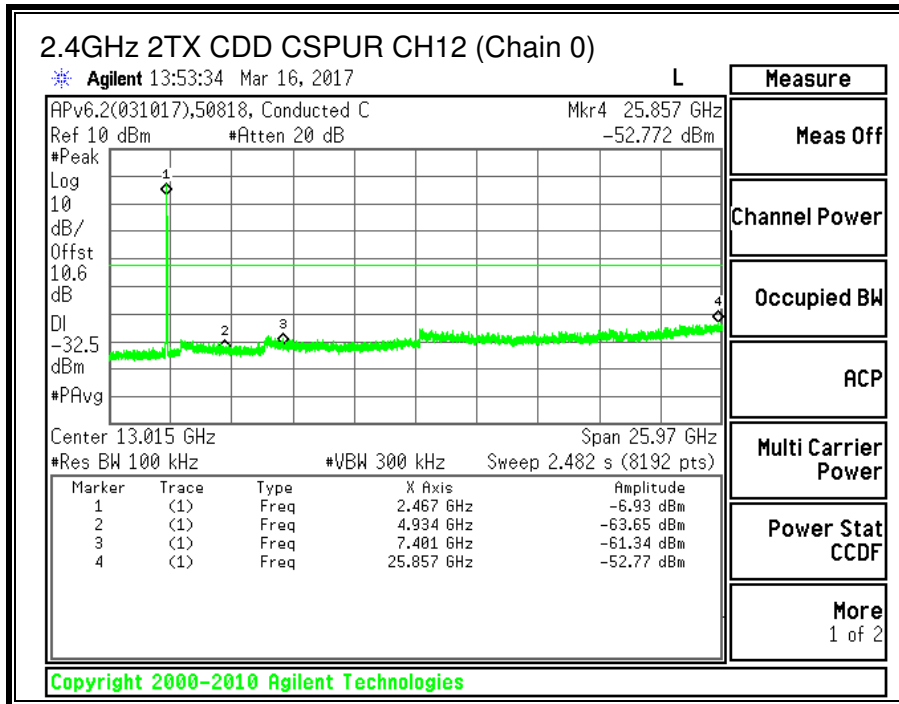

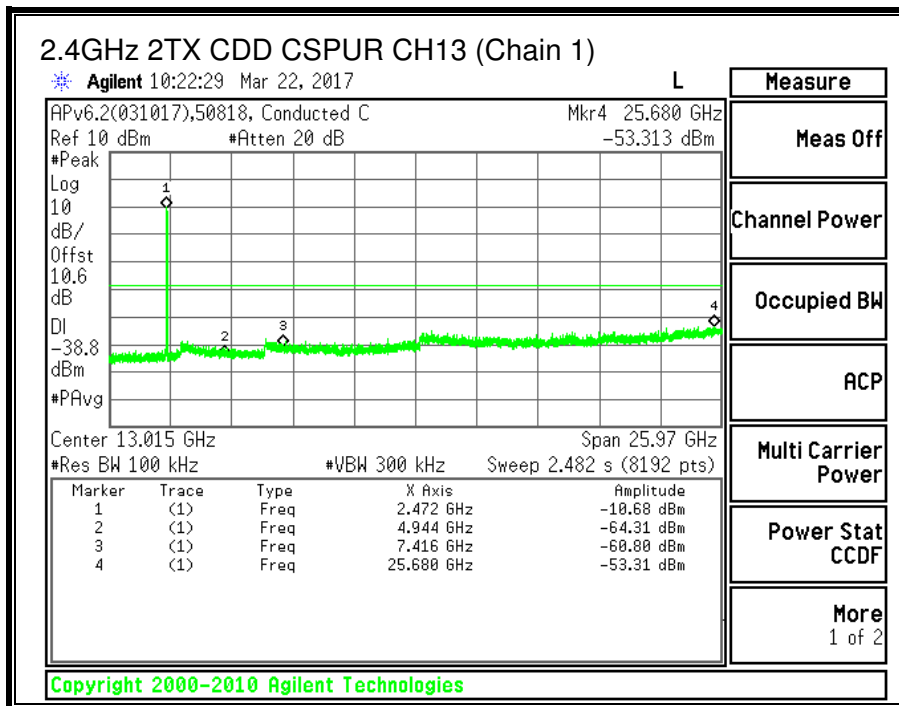
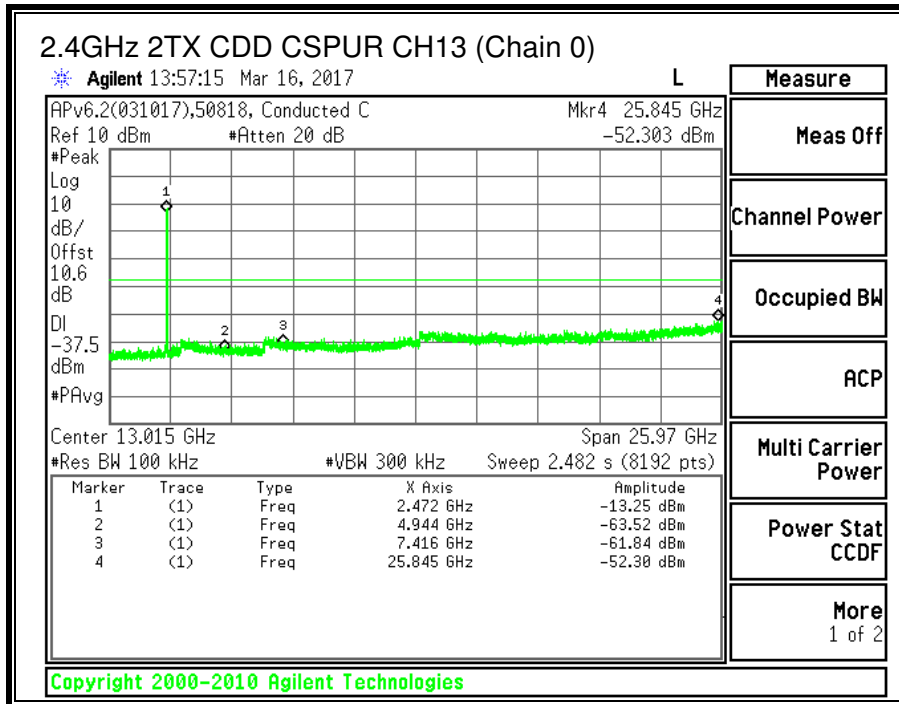

10. RADIATED TEST RESULTS

10.1. LIMITS AND PROCEDURE

LIMITS

FCC §15.205 and §15.209
IC RSS-GEN, Section 8.9 and 8.10.

Frequency Range (MHz)	Field Strength Limit (uV/m) at 3 m	Field Strength Limit (dBuV/m) at 3 m
0.009-0.490	2400/F(kHz) @ 300 m	-
0.490-1.705	24000/F(kHz) @ 30 m	-
1.705 - 30	30 @ 30m	-
30 - 88	100	40
88 - 216	150	43.5
216 - 960	200	46
Above 960	500	54

TEST PROCEDURE

The EUT is placed on a non-conducting table 80 cm above the ground plane for measurement below 1GHz; 1.5 m above the ground plane for measurement above 1GHz. The antenna to EUT distance is 3 meters. The EUT is configured in accordance with ANSI C63.10. The EUT is set to transmit in a continuous mode.

For measurements below 1 GHz the resolution bandwidth is set to 120 kHz for peak detection measurements or 120 kHz for quasi-peak detection measurements for the 30-1000 MHz range, 9 kHz for peak detection measurements or 9 kHz for quasi-peak detection measurements for the 0.15-30 MHz range and 200 Hz for peak detection measurements or 200 Hz for quasi-peak detection measurements for the 9 to 150 kHz range. Peak detection is used unless otherwise noted as quasi-peak.

For pre-scans above 1 GHz the resolution bandwidth is set to 1 MHz; the video bandwidth is set to 30 KHz for peak measurements.

For final measurements above 1 GHz the resolution bandwidth is set to 1 MHz; the video bandwidth is set to 3 MHz for peak measurements and as applicable for average measurements.

The spectrum from 30 MHz to 26 GHz is investigated with the transmitter set to the lowest, middle, and highest channels in the 2.4 GHz band.

The frequency range of interest is monitored at a fixed antenna height and EUT azimuth. The EUT is rotated through 360 degrees to maximize emissions received. The antenna is scanned from 1 to 4 meters above the ground plane to further maximize the emission. Measurements are made with the antenna polarized in both the vertical and the horizontal positions

10.2. TRANSMITTER ABOVE 1 GHz

10.2.1 11b Chain 0 and Chain 1 MIMO MODE IN THE 2.4GHz BAND

AUTHORIZED BANDEDGE (LOW CHANNEL, CH 1)

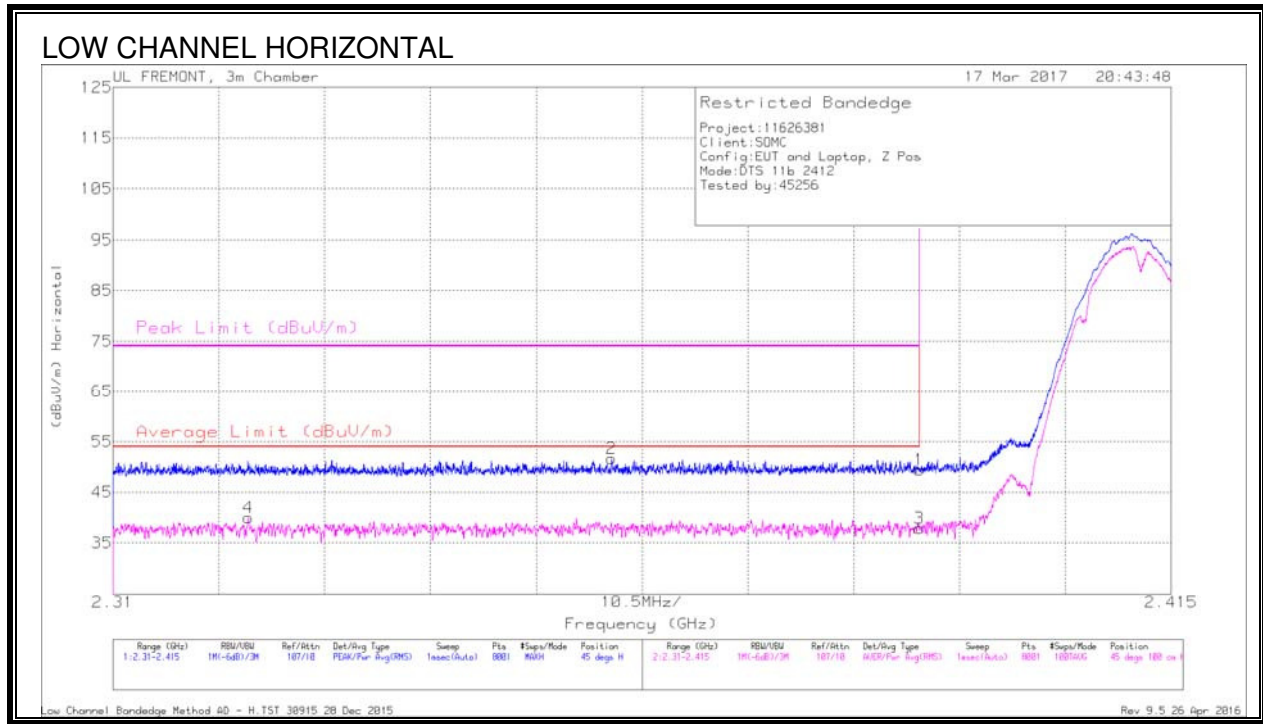

Trace Markers

Marker	Frequency (GHz)	Meter Reading (dBuV)	Det	AF T712 (dB/m)	Amp/Cb/Ftr/Pad (dB)	Corrected Reading (dBuV/m)	Average Limit (dBuV/m)	Margin (dB)	Peak Limit (dBuV/m)	PK Margin (dB)	Azimuth (Degs)	Height (cm)	Polarity
4	2.323	29.04	RMS	31.8	-20.8	40.04	54	-13.96	-	-	45	100	H
2	2.359	40.61	Pk	31.9	-20.9	51.61	-	-	74	-22.39	45	100	H
1	2.39	38.37	Pk	31.9	-20.8	49.47	-	-	74	-24.53	45	100	H
3	2.39	26.74	RMS	31.9	-20.8	37.84	54	-16.16	-	-	45	100	H

Pk - Peak detector
 RMS - RMS detection

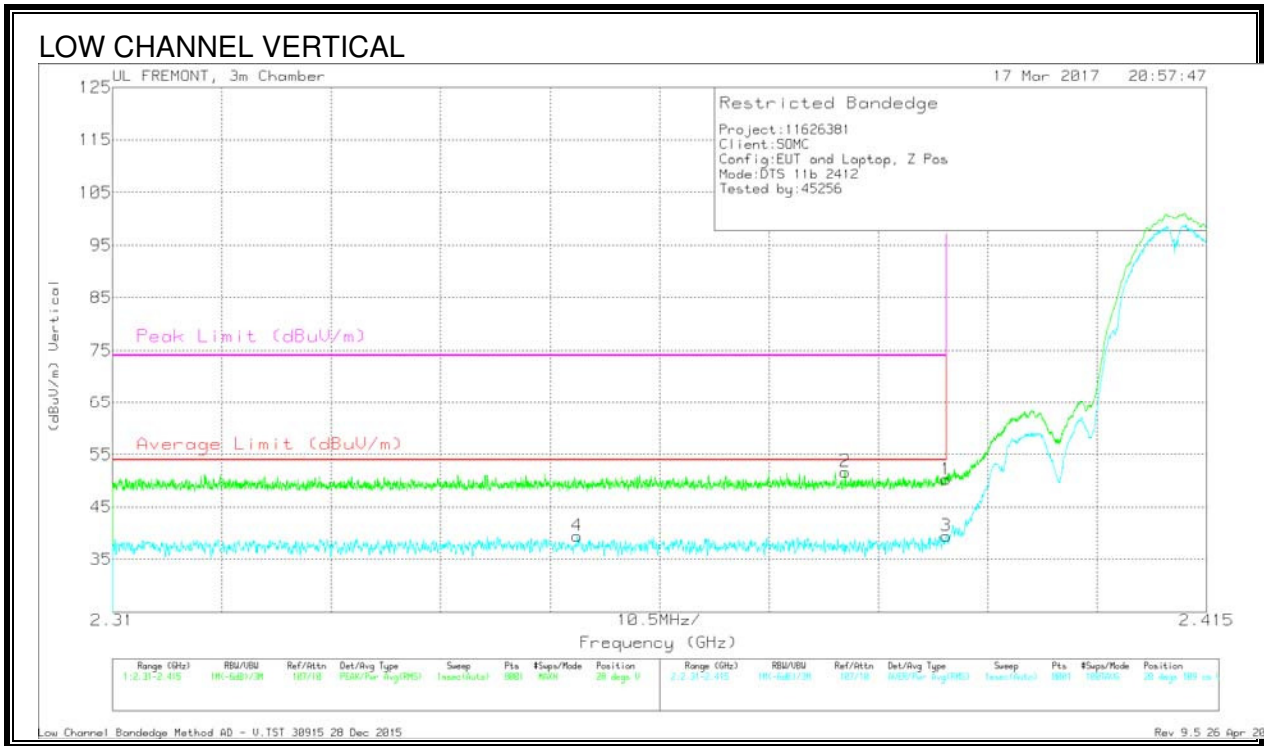

Trace Markers

Marker	Frequency (GHz)	Meter Reading (dBuV)	Det	AF T712 (dB/m)	Amp/Cbl/Filtr/Pad (dB)	Corrected Reading (dBuV/m)	Average Limit (dBuV/m)	Margin (dB)	Peak Limit (dBuV/m)	PK Margin (dB)	Azimuth (Degs)	Height (cm)	Polarity
4	2.355	28.42	RMS	31.9	-20.8	39.52	54	-14.48	-	-	28	109	V
2	2.38	40.62	Pk	31.9	-20.8	51.72	-	-	74	-22.28	28	109	V
1	2.39	39.17	Pk	31.9	-20.8	50.27	-	-	74	-23.73	28	109	V
3	2.39	28.34	RMS	31.9	-20.8	39.44	54	-14.56	-	-	28	109	V

Pk - Peak detector
 RMS - RMS detection

AUTHORIZED BANDEDGE (HIGH CHANNEL, CH 11)

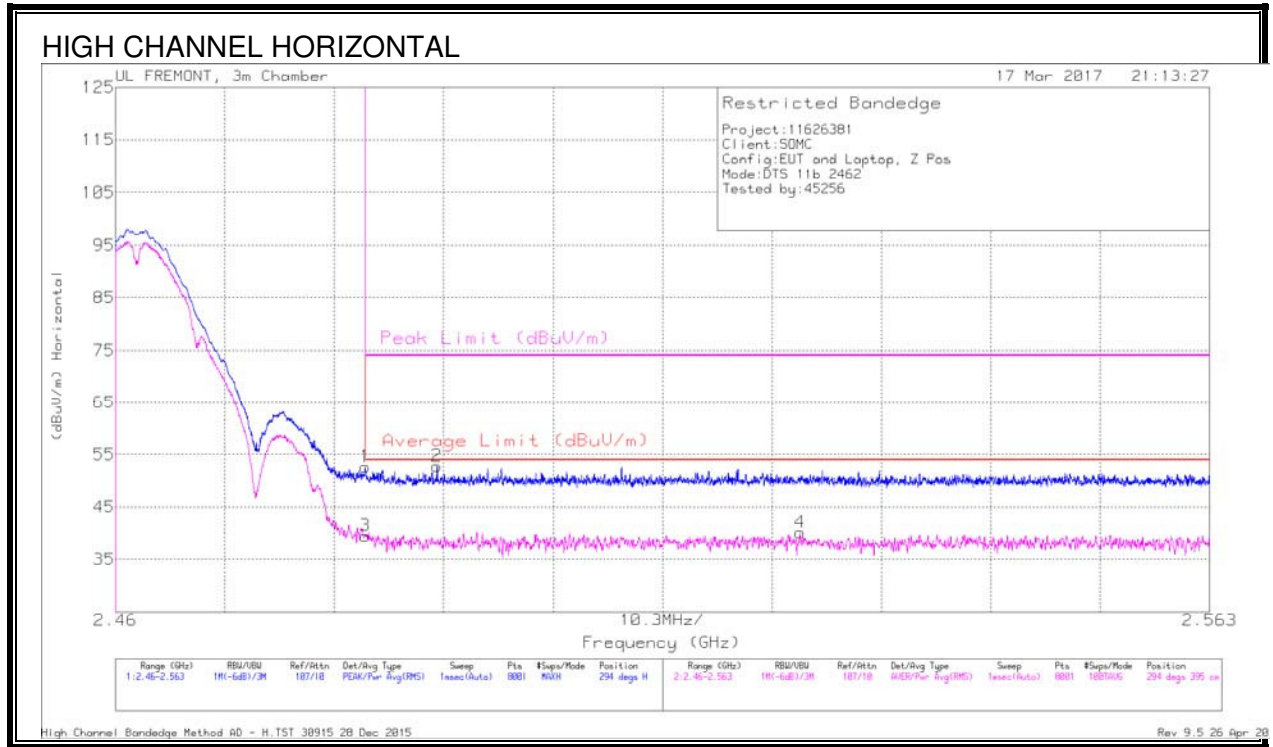

Trace Markers

Marker	Frequency (GHz)	Meter Reading (dBuV)	Det	AF T712 (dB/m)	Amp/Cbl/Filtr/Pad (dB)	Corrected Reading (dBuV/m)	Average Limit (dBuV/m)	Margin (dB)	Peak Limit (dBuV/m)	PK Margin (dB)	Azimuth (Degs)	Height (cm)	Polarity
1	2.484	41.04	Pk	32.4	-20.8	52.64	-	-	74	-21.36	294	395	H
3	2.484	27.84	RMS	32.4	-20.8	39.44	54	-14.56	-	-	294	395	H
2	2.49	41.09	Pk	32.5	-20.8	52.79	-	-	74	-21.21	294	395	H
4	2.524	28.35	RMS	32.4	-20.6	40.15	54	-13.85	-	-	294	395	H

Pk - Peak detector
 RMS - RMS detection

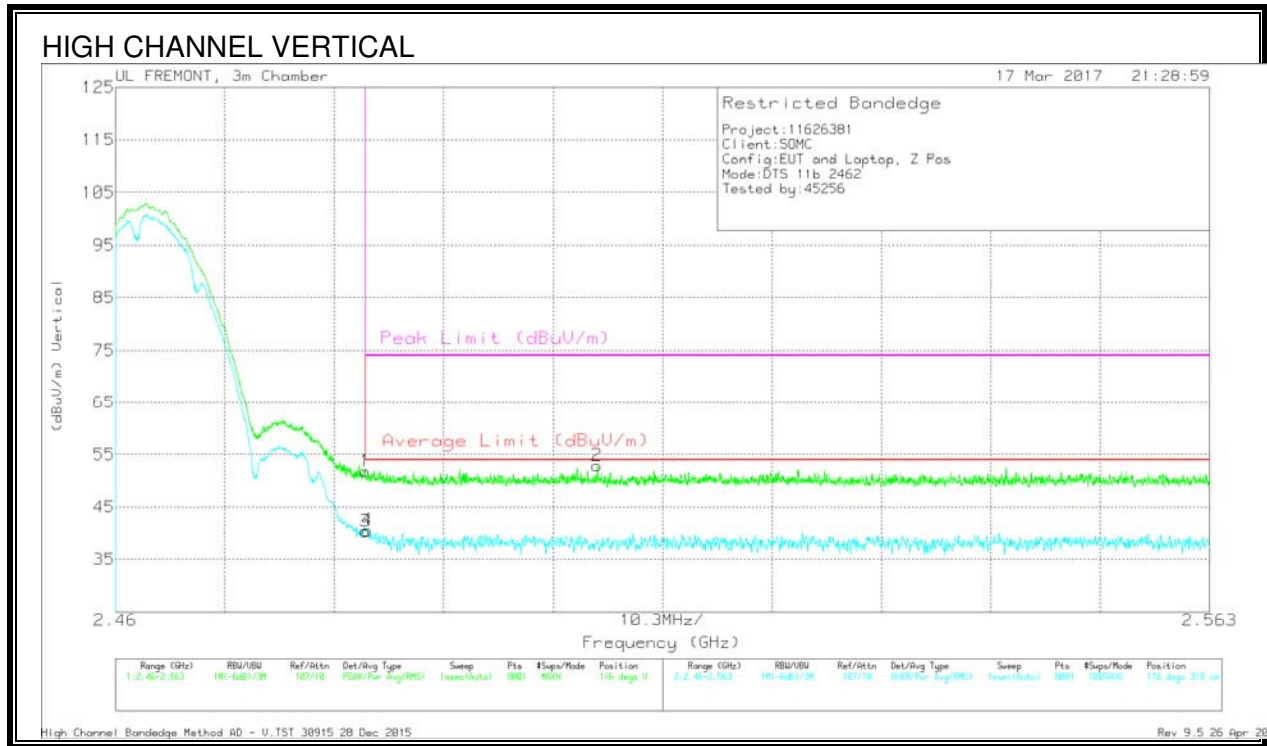

Trace Markers

Marker	Frequency (GHz)	Meter Reading (dBuV)	Det	AF T712 (dB/m)	Amp/Cbl/Filtr/Pad (dB)	Corrected Reading (dBuV/m)	Average Limit (dBuV/m)	Margin (dB)	Peak Limit (dBuV/m)	PK Margin (dB)	Azimuth (Degs)	Height (cm)	Polarity
1	2.484	40.17	Pk	32.4	-20.8	51.77	-	-	74	-22.23	116	319	V
3	2.484	28.71	RMS	32.4	-20.8	40.31	54	-13.69	-	-	116	319	V
4	2.484	28.94	RMS	32.4	-20.8	40.54	54	-13.46	-	-	116	319	V
2	2.505	41.2	Pk	32.5	-20.8	52.9	-	-	74	-21.1	116	319	V

Pk - Peak detector
 RMS - RMS detection

AUTHORIZED BANDEDGE (HIGH CHANNEL, CH 12)

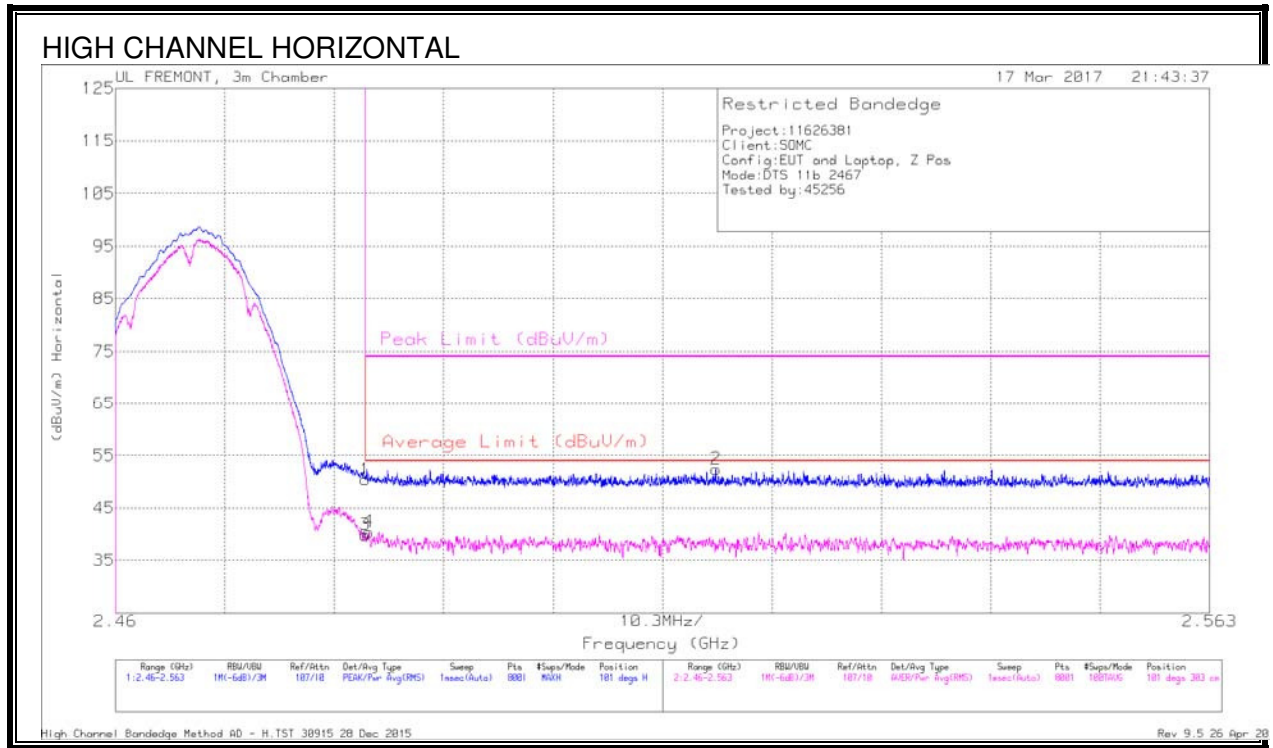

Trace Markers

Marker	Frequency (GHz)	Meter Reading (dBuV)	Det	AF T712 (dB/m)	Amp/Cb/Fltr/Pad (dB)	Corrected Reading (dBuV/m)	Average Limit (dBuV/m)	Margin (dB)	Peak Limit (dBuV/m)	PK Margin (dB)	Azimuth (Degs)	Height (cm)	Polarity
1	2.484	38.76	Pk	32.4	-20.8	50.36	-	-	74	-23.64	101	303	H
3	2.484	28.29	RMS	32.4	-20.8	39.89	54	-14.11	-	-	101	303	H
4	2.484	28.82	RMS	32.4	-20.8	40.42	54	-13.58	-	-	101	303	H
2	2.517	40.69	Pk	32.5	-20.8	52.39	-	-	74	-21.61	101	303	H

Pk - Peak detector
 RMS - RMS detection

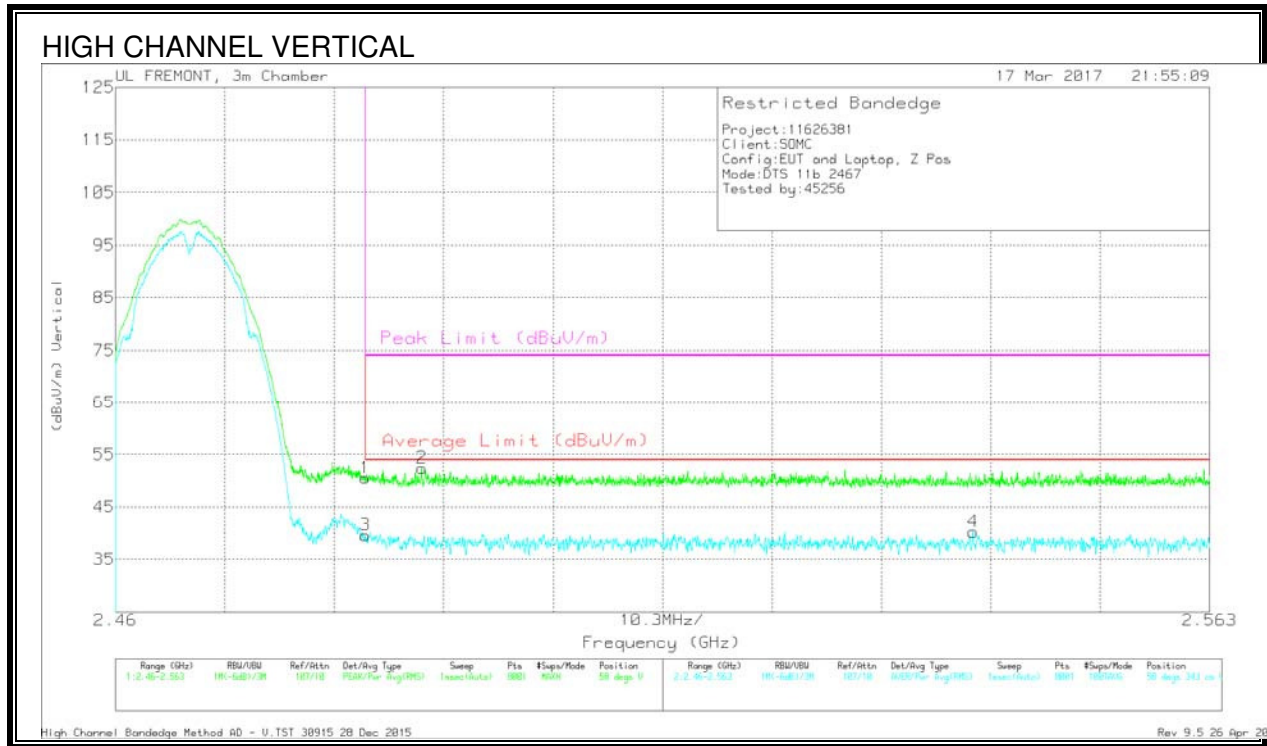

Trace Markers

Marker	Frequency (GHz)	Meter Reading (dBuV)	Det	AF T712 (dB/m)	Amp/Cbl/Filtr/Pad (dB)	Corrected Reading (dBuV/m)	Average Limit (dBuV/m)	Margin (dB)	Peak Limit (dBuV/m)	PK Margin (dB)	Azimuth (Degs)	Height (cm)	Polarity
1	2.484	38.95	Pk	32.4	-20.8	50.55	-	-	74	-23.45	58	343	V
3	2.484	27.98	RMS	32.4	-20.8	39.58	54	-14.42	-	-	58	343	V
2	2.489	40.91	Pk	32.4	-20.9	52.41	-	-	74	-21.59	58	343	V
4	2.541	28.64	RMS	32.4	-20.8	40.24	54	-13.76	-	-	58	343	V

Pk - Peak detector
 RMS - RMS detection

AUTHORIZED BANDEDGE (HIGH CHANNEL, CH 13)

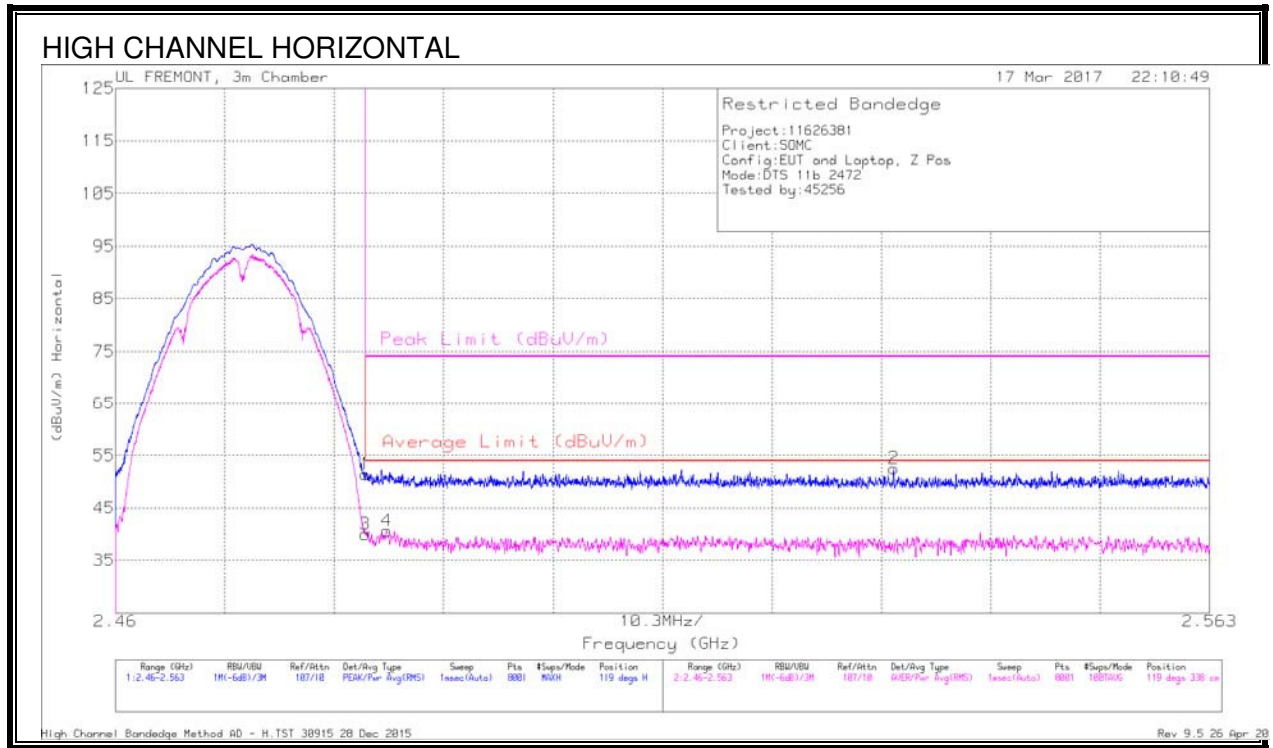

Trace Markers

Marker	Frequency (GHz)	Meter Reading (dBuV)	Det	AF T712 (dB/m)	Amp/Cb/Fltr/Pad (dB)	Corrected Reading (dBuV/m)	Average Limit (dBuV/m)	Margin (dB)	Peak Limit (dBuV/m)	PK Margin (dB)	Azimuth (Degs)	Height (cm)	Polarity
1	2.484	39.86	Pk	32.4	-20.8	51.46	-	-	74	-22.54	119	338	H
3	2.484	28.42	RMS	32.4	-20.8	40.02	54	-13.98	-	-	119	338	H
4	2.486	29.16	RMS	32.4	-20.9	40.66	54	-13.34	-	-	119	338	H
2	2.533	41.07	Pk	32.4	-20.9	52.57	-	-	74	-21.43	119	338	H

Pk - Peak detector
 RMS - RMS detection

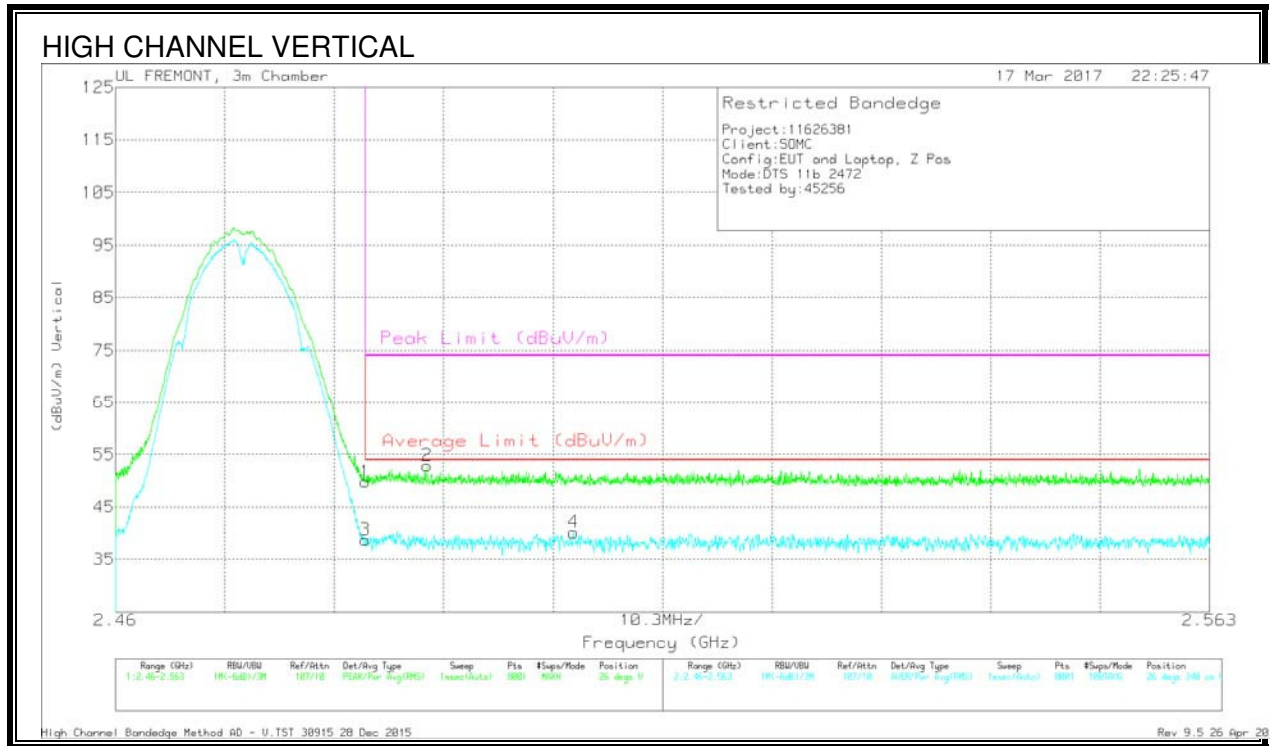

Trace Markers

Marker	Frequency (GHz)	Meter Reading (dBuV)	Det	AF T712 (dB/m)	Amp/Cbl/Filtr/Pad (dB)	Corrected Reading (dBuV/m)	Average Limit (dBuV/m)	Margin (dB)	Peak Limit (dBuV/m)	PK Margin (dB)	Azimuth (Degs)	Height (cm)	Polarity
1	2.484	38.19	Pk	32.4	-20.8	49.79	-	-	74	-24.21	26	340	V
3	2.484	27.12	RMS	32.4	-20.8	38.72	54	-15.28	-	-	26	340	V
2	2.489	41.28	Pk	32.4	-20.8	52.88	-	-	74	-21.12	26	340	V
4	2.503	28.47	RMS	32.5	-20.8	40.17	54	-13.83	-	-	26	340	V

Pk - Peak detector
 RMS - RMS detection

HARMONICS AND SPURIOUS EMISSIONS (LOW CHANNEL, CH 1)

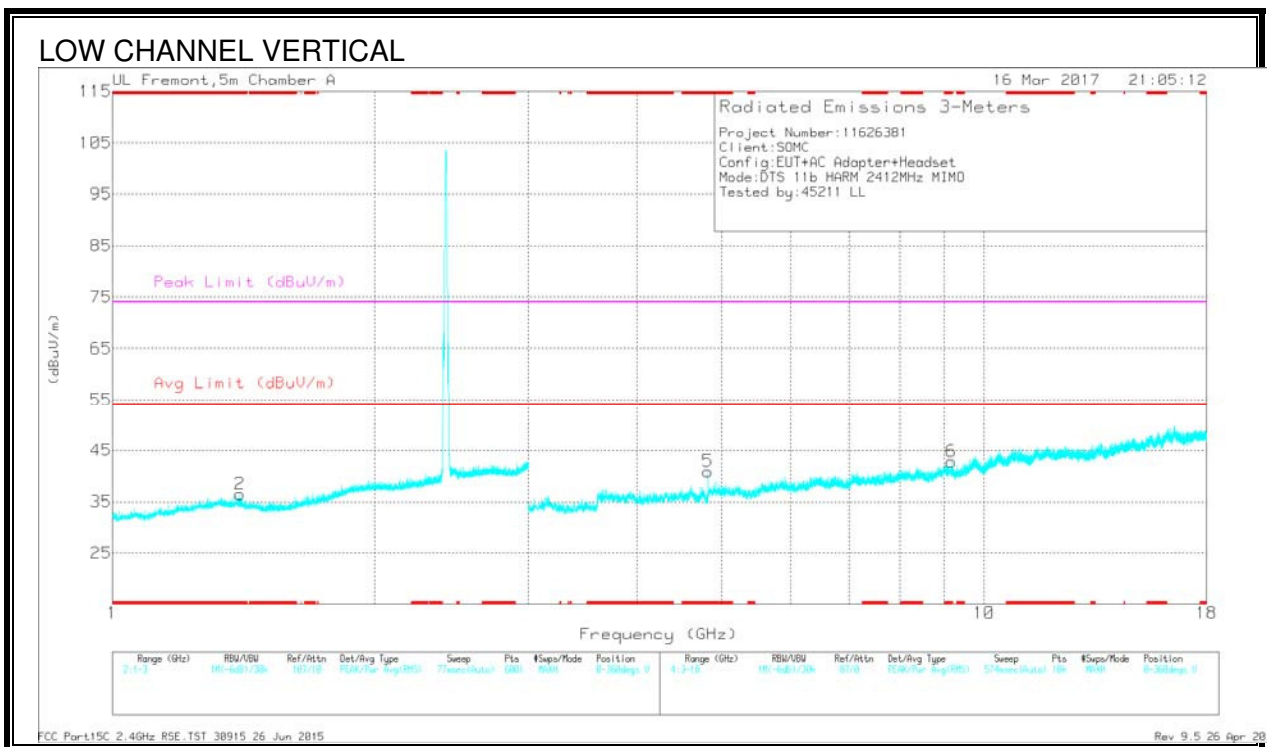
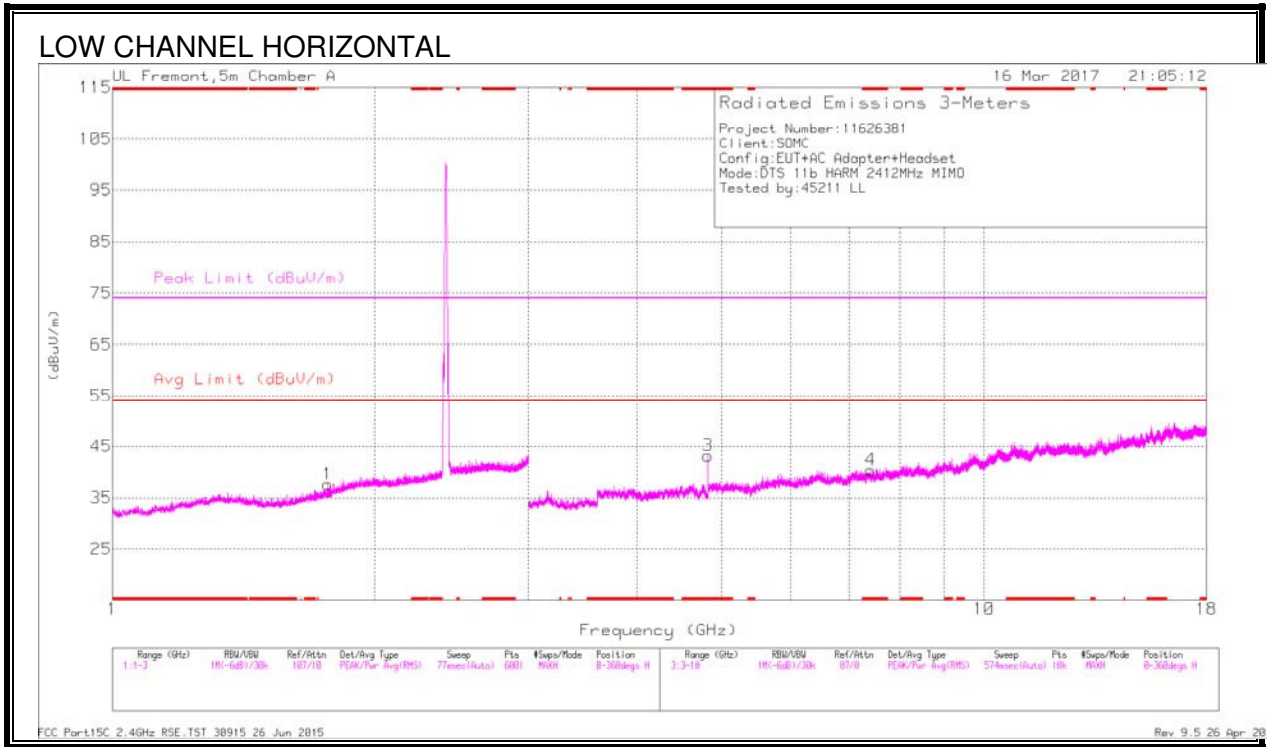

Radiated Emissions

Frequency (GHz)	Meter Reading (dBuV)	Det	AF T711 (dB/m)	Amp/Cbl/Filtr/Pad (dB)	DC Corr (dB)	Corrected Reading (dBuV/m)	Avg Limit (dBuV/m)	Margin (dB)	Peak Limit (dBuV/m)	PK Margin (dB)	Azimuth (Degs)	Height (cm)	Polarity
* 1.398	35.62	PK2	29.2	-23.8	0	41.02	-	-	74	-32.98	36	112	V
* 1.4	25.19	MAV1	29.2	-23.7	0	30.69	54	-23.31	-	-	36	112	V
* 4.824	42.06	PK2	34	-28.2	0	47.86	-	-	74	-26.14	252	114	H
* 4.824	36.65	MAV1	34	-28.2	0	42.45	54	-11.55	-	-	252	114	H
* 7.414	34.56	PK2	35.5	-23.5	0	46.56	-	-	74	-27.44	242	125	H
* 7.412	23.74	MAV1	35.5	-23.6	0	35.64	54	-18.36	-	-	242	125	H
* 4.824	39.99	PK2	34	-28.2	0	45.79	-	-	74	-28.21	232	113	V
* 4.824	34.71	MAV1	34	-28.2	0	40.51	54	-13.49	-	-	232	113	V
* 9.169	33.06	PK2	36.1	-22	0	47.16	-	-	74	-26.84	253	188	V
* 9.168	23.64	MAV1	36.1	-22	0	37.74	54	-16.26	-	-	253	188	V
1.766	36.34	PK2	29.9	-23.8	0	42.44	-	-	-	-	5	105	H
1.768	25.29	MAV1	30	-23.8	0	31.49	-	-	-	-	5	105	H

* - indicates frequency in CFR15.205/RSS-GEN 8.10 -Restricted Band

PK2 - KDB558074 Method: Maximum Peak

MAV1 - KDB558074 Option 1 Maximum RMS Average

HARMONICS AND SPURIOUS EMISSIONS (MID CHANNEL, CH 7)

