

Startup Guide

XPERIA™ Agent

XXXXX

For the detailed descriptions of how to use, see the user guide.
<http://www.xxxxxxxxxxxxx>

Preparing

Basic package

- Xperia™ Agent (main unit)
- AC adapter
- Power cord

Names of parts

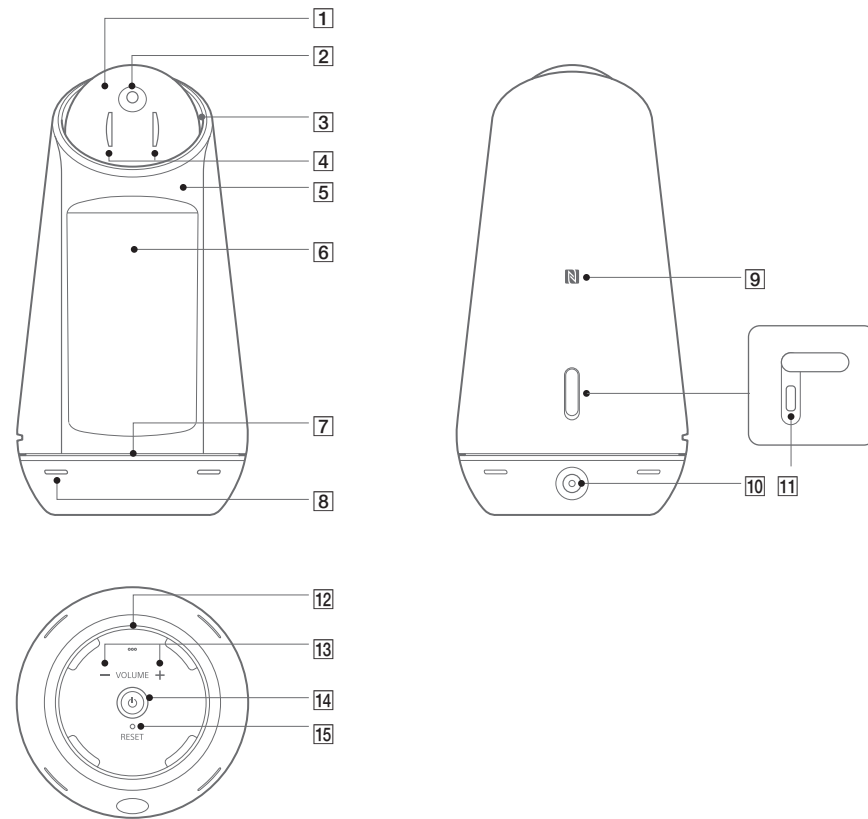

- | | | |
|------------------------|--------------------------|----------------------------------|
| 1 Head Switch | 6 Display (Touch screen) | 11 USB Type-C™ Jack |
| 2 Camera | 7 Microphone | 12 Temperature & Humidity sensor |
| 3 LED/Speaker | 8 Human detect sensor | 13 Volume up/down key |
| 4 Agent eyes | 9 NFC (NFC) mark | 14 Power key |
| 5 Ambient light sensor | 10 DC IN jack | 15 Reset Switch |

Turning the power on

- 1 Connect the power cord (included) to the AC adapter (included)
- 2 Connect the AC adapter to the DC IN jack of Xperia™ Agent
- 3 Firmly insert the power plug of power cord into an outlet

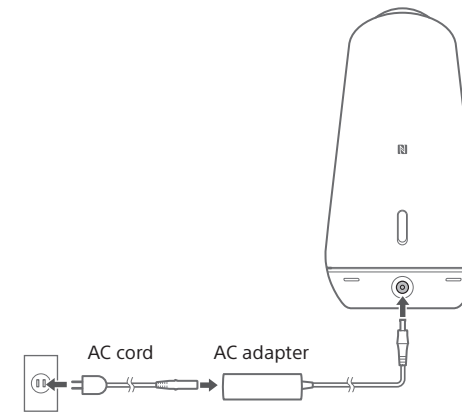

- 4 Press the power key of Xperia™ Agent
 The display lights and the wake-up screen appears.
 When "ようこそ (Welcome)" screen appears, go to "Initial settings of Android".

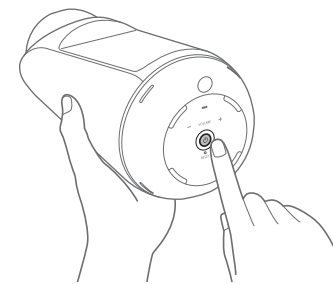

To power off, press and hold the power key.

Initial settings of Android

- 1 In the "ようこそ (Welcome)" screen, tap [開始する (Start)]

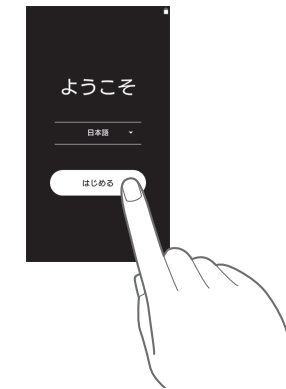

- To change the language, tap "日本語 (Japanese)" and then select a desired language.

- 2 In "重要なお知らせ (Important information)" screen, confirm the content and then tap [次へ (Next)]



- 3 Follow the onscreen instructions to set up the following items

- Wi-Fi
- Google account
- Xperia™ services

- 4 In "セットアップ完了! (Setup is complete)" screen, tap [終了 (Finish)]



The home screen appears.
 Go to "Initial settings of Xperia™ Agent" in "Settings" on the next page.



Settings

Initial settings of Xperia™ Agent

Register a name and face of user. Up to 10 users can be registered.

1 In the home screen, tap “Xperia Agentを使い始める (Start using Xperia Agent)”



Xperia™ Agent gives you a greeting. When Xperia™ Agent says something, the LED blinks.

Hajimemashite. Watashi wa Ekusuperia Eijent desu. (How do you do. I'm Xperia Agent.)

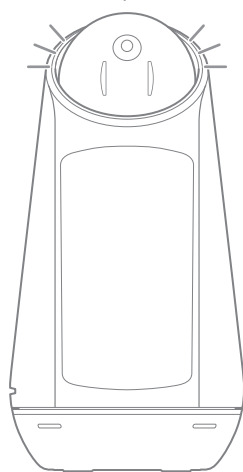

2 Register your name

Following the Xperia™ Agent's instruction, speak your name to register. LED status changes from blinking to lighting when the Xperia™ Agent hears your voice.

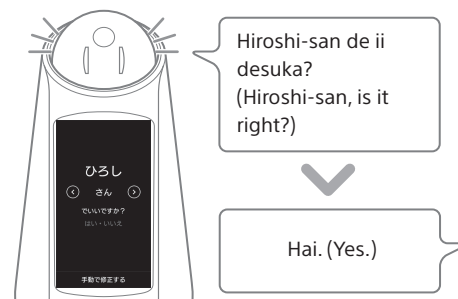

- If the name is not recognized correctly, speak "lie (No)" and your name again.
- To correct the name manually, tap [手動で修正する (Correct manually)] and then enter the name with the keyboard on the display.
- You can select [さん (san)], [ちゃん (chan)], [くん (kun)], [様 (sama)] or [(なし (None))]. Tap (<) or (>) to toggle the option.

3 Register your face

Following the Xperia™ Agent's instruction, register your face. Your profile photo will also be taken after the registration.



Tap [許可する (Allow)]

Turn your face toward the camera

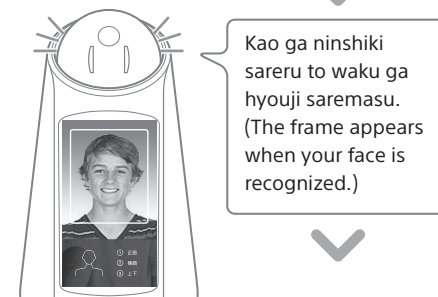

Following the Xperia™ Agent's instruction, turn your face direction



Center your face in the circle frame and tap [撮影する (Shoot)]



To reshoot the profile photo, answer "lie (No)" and then shoot again.

4 Register the next user / End the registration

- To register the other user in a row, tap [他の家族を登録する (Register other family member)] and then register his/her name and face.
- To end the user registration, tap [次へ (Next)].

Using

Checking how to use

Learn how to use the Xperia™ Agent through dialogue. You can set to notify you of weather forecast, news, etc. as a greeting message.

1 Check how to speak

Following the Xperia™ Agent's instruction, speak to the Xperia™ Agent.

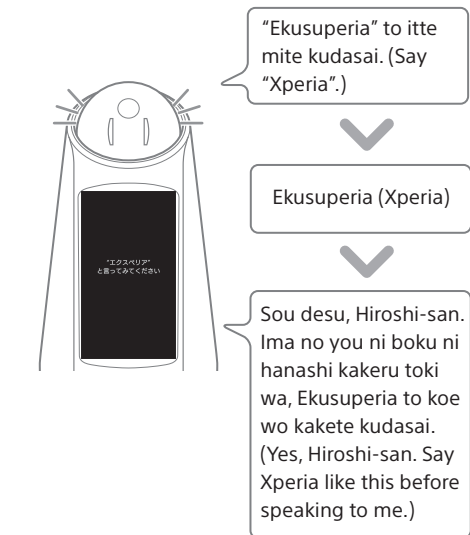

2 Set the greeting message

Following the Xperia™ Agent's instruction, speak to the Xperia™ Agent.

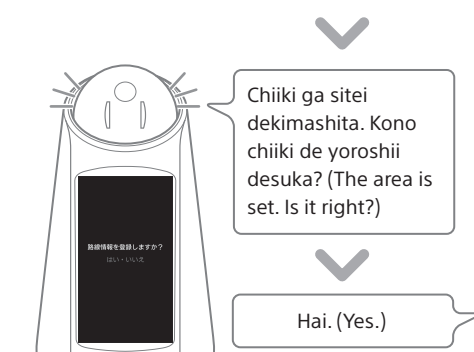
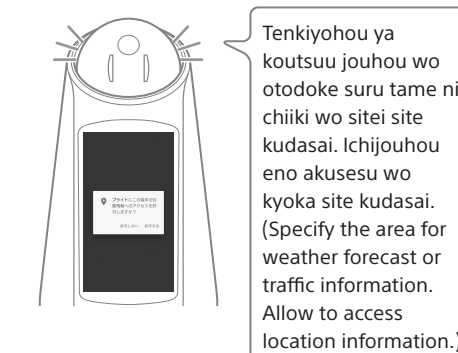

- If the area is not recognized correctly, tap [いいえ (No)] and then select a desired area following the onscreen instructions.

3 Check other things that can be done

The Xperia™ Agent introduces other things that can be done.

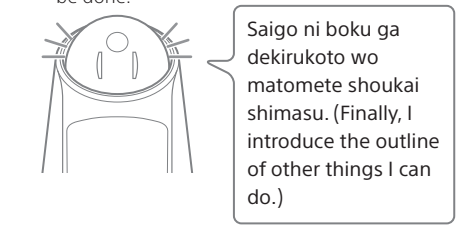

● Try to speak

Say "Hai, Ekusuperia (Hi, Xperia)" and then speak a greeting or question. The Xperia™ Agent will answer you.

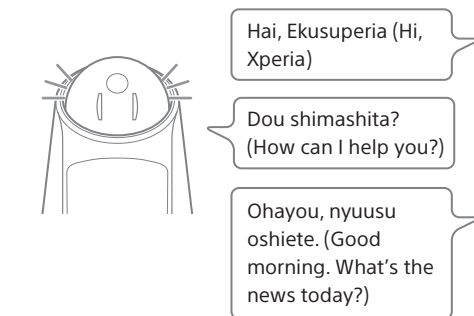

Using

The Xperia™ Agent can respond the following greetings.

- Ohayou (Good morning)
- Kon-nichiwa (Good afternoon)
- Konbanwa (Good evening)
- Oyasumi (Good night)
- Ittekimasu (See you later)
- Tadaima (I'm home)
- Bai bai (Bye-bye)
- Sayounara (Good bye)
- Yoroshiku ne (Nice to meet you)
- Onegai (Please)
- Gomen ne (Sorry)
- Arigatou (Thank you)
- Akemashite omedetou (A happy new year)
- Merii kurisumasu (Merry Christmas)