

HAC_E_Dipole_835

DUT: HAC-Dipole 835 MHz

Communication System: CW; Frequency: 835 MHz; Duty Cycle: 1:1
 Medium: Air Medium parameters used: $\sigma = 0$ S/m, $\epsilon_r = 1$; $\rho = 0$ kg/m³
 Ambient Temperature : 23.3 °C

DASY5 Configuration:

- Probe: ER3DV6 - SN2358; ConvF(1, 1, 1); Calibrated: 2018/1/19;
- Sensor-Surface: (Fix Surface)
- Electronics: DAE4 Sn1326; Calibrated: 2018/9/18
- Phantom: HAC Test Arch with AMCC; Type: SD HAC P01 BA;
- Measurement SW: DASY52, Version 52.10 (0); SEMCAD X Version 14.6.10 (7417)

E Scan - measurement distance from the probe sensor center to CD835 = 10mm & 15mm/Hearing Aid Compatibility Test at 15mm distance (41x361x1): Interpolated grid:

dx=0.5000 mm, dy=0.5000 mm
 Device Reference Point: 0, 0, -6.3 mm
 Reference Value = 105.1 V/m; Power Drift = -0.09 dB
 PMR not calibrated. PMF = 1.000 is applied.
 E-field emissions = 109.1 V/m
 Average value of Total=(109.1+103.7) / 2 = 106.4 V/m

PMF scaled E-field

Grid 1 M4 107.8 V/m	Grid 2 M4 109.1 V/m	Grid 3 M4 107.2 V/m
Grid 4 M4 66.66 V/m	Grid 5 M4 67.01 V/m	Grid 6 M4 65.56 V/m
Grid 7 M4 102.9 V/m	Grid 8 M4 103.7 V/m	Grid 9 M4 101.1 V/m

Cursor:

Total = 109.1 V/m
 E Category: M4
 Location: 0.5, -69, 9.7 mm

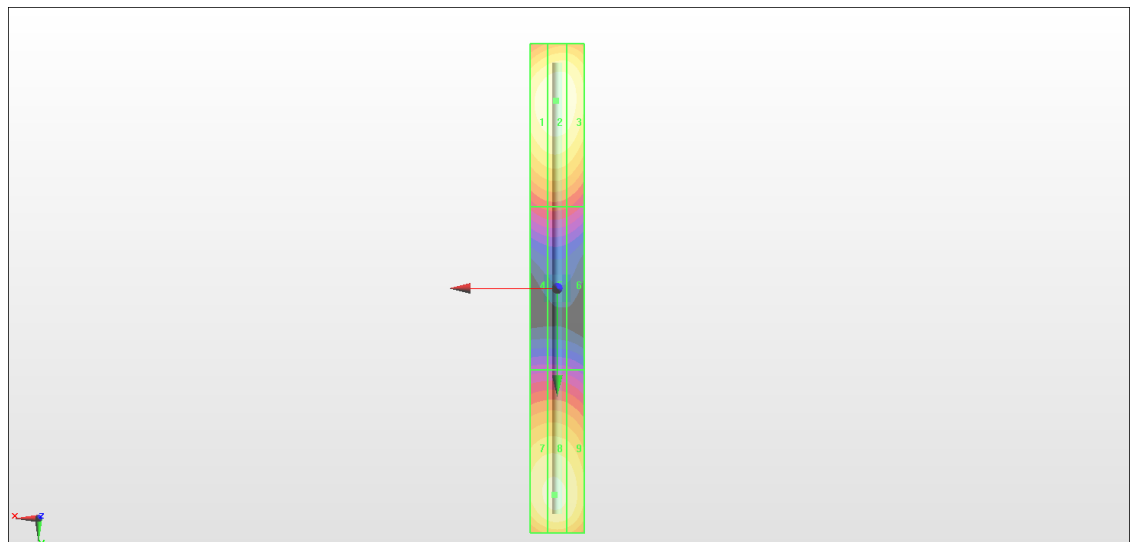
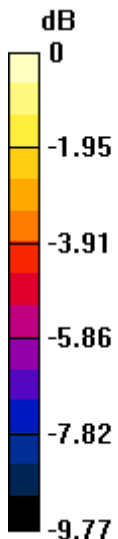

0 dB = 109.1 V/m = 40.76 dBV/m

HAC_E_Dipole_1880

DUT: HAC Dipole 1880 MHz

Communication System: CW; Frequency: 1880 MHz; Duty Cycle: 1:1
 Medium: Air Medium parameters used: $\sigma = 0$ S/m, $\epsilon_r = 1$; $\rho = 0$ kg/m³
 Ambient Temperature : 23.3 °C

DASY5 Configuration:

- Probe: ER3DV6 - SN2358; ConvF(1, 1, 1); Calibrated: 2018/1/19;
- Sensor-Surface: (Fix Surface)
- Electronics: DAE4 Sn1326; Calibrated: 2018/9/18
- Phantom: HAC Test Arch with AMCC; Type: SD HAC P01 BA;
- Measurement SW: DASY52, Version 52.10 (0); SEMCAD X Version 14.6.10 (7417)

E Scan - measurement distance from the probe sensor center to CD1880 = 10mm & 15mm/Hearing Aid Compatibility Test at 15mm distance (41x181x1): Interpolated grid:

$dx=0.5000$ mm, $dy=0.5000$ mm
 Device Reference Point: 0, 0, -6.3 mm
 Reference Value = 132.7 V/m; Power Drift = 0.01 dB
 PMR not calibrated. PMF = 1.000 is applied.
 E-field emissions = 85.69 V/m
 Average value of Total= $(83.7+85.69) / 2 = 84.695$ V/m

PMF scaled E-field

Grid 1 M3 82.63 V/m	Grid 2 M3 83.70 V/m	Grid 3 M3 82.01 V/m
Grid 4 M3 65.31 V/m	Grid 5 M3 66.65 V/m	Grid 6 M3 65.93 V/m
Grid 7 M3 83.88 V/m	Grid 8 M3 85.69 V/m	Grid 9 M3 84.17 V/m

Cursor:

Total = 85.69 V/m
 E Category: M3
 Location: 0, 31, 9.7 mm

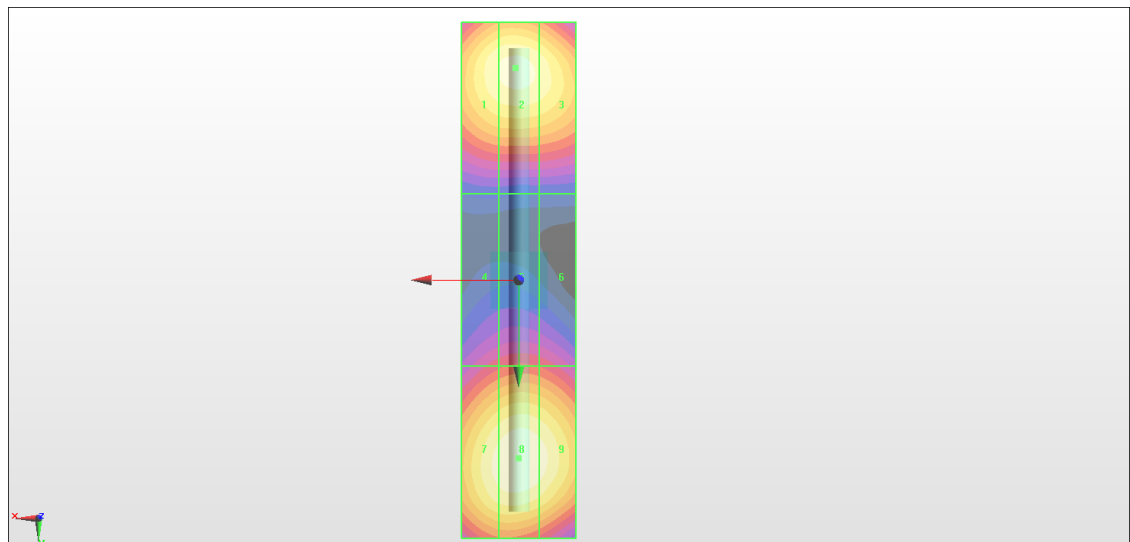
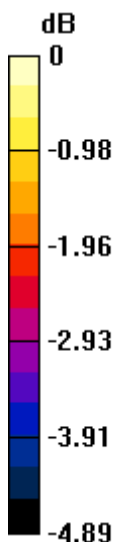

0 dB = 85.69 V/m = 38.66 dBV/m