



FCC RADIO TEST REPORT

FCC ID : PY7-23855M
Equipment : GSM/WCDMA/LTE Phone with BT, DTS/UNII
a/b/g/n/ac/ax, GPS, and NFC
Brand Name : Sony
Applicant : Sony Mobile Communications Inc.
4-12-3 Higashi-Shinagawa, Shinagawa-ku,
Tokyo, 140-0002, Japan
Manufacturer : Sony Mobile Communications Inc.
4-12-3 Higashi-Shinagawa, Shinagawa-ku,
Tokyo, 140-0002, Japan
Standard : FCC Part 15 Subpart C §15.247

The product was received on Jul. 10, 2020 and testing was started from Aug. 04, 2020 and completed on Aug. 21, 2020. We, SPORTON INTERNATIONAL INC., EMC & Wireless Communications Laboratory, would like to declare that the tested sample has been evaluated in accordance with the test procedures and has been in compliance with the applicable technical standards.

The test results in this spot check data report apply exclusively to the tested model / sample. Without written approval of SPORTON INTERNATIONAL INC. EMC & Wireless Communications Laboratory, the test report shall not be reproduced except in full.

Louis Wu

Approved by: Louis Wu

SPORTON INTERNATIONAL INC. EMC & Wireless Communications Laboratory
No. 52, Huaya 1st Rd., Guishan Dist., Taoyuan City, Taiwan (R.O.C.)



Table of Contents

History of this test report.....	3
Summary of Test Result.....	4
1 General Description	5
1.1 Product Feature of Equipment Under Test.....	5
1.2 Modification of EUT	5
1.3 Testing Location	6
1.4 Applicable Standards.....	6
2 Test Configuration of Equipment Under Test	7
2.1 Carrier Frequency and Channel	7
2.2 Test Mode.....	7
2.3 Connection Diagram of Test System.....	8
2.4 EUT Operation Test Setup	8
3 Test Result	9
3.1 Output Power Measurement.....	9
3.2 Radiated Band Edges and Spurious Emission Measurement	10
3.3 Antenna Requirements	15
4 List of Measuring Equipment.....	16
5 Uncertainty of Evaluation	17
Appendix A. Conducted Test Results	
Appendix B. Radiated Spurious Emission	
Appendix C. Radiated Spurious Emission Plots	
Appendix D. Duty Cycle Plots	



History of this test report

Report No.	Version	Description	Issued Date
FR042245-02C	01	Initial issue of report	Aug. 24, 2020



Summary of Test Result

Report Clause	Ref Std. Clause	Test Items	Result (PASS/FAIL)	Remark
-	15.247(a)(2)	6dB Bandwidth	-	See Note
-	2.1049	99% Occupied Bandwidth	-	See Note
3.1	15.247(b)	Power Output Measurement	Pass	-
-	15.247(e)	Power Spectral Density	-	See Note
-	15.247(d)	Conducted Band Edges	-	See Note
		Conducted Spurious Emission	-	See Note
3.2	15.247(d)	Radiated Band Edges and Radiated Spurious Emission	Pass	Under limit 6.47 dB at 41.640 MHz
-	15.207	AC Conducted Emission	-	See Note
3.3	15.203 & 15.247(b)	Antenna Requirement	Pass	-

Note: The RF circuit, output power level and antenna performance is the same in WLAN function across all two FCC ID PY7-23855M and PY7-08372L, since the change, only verify RF output power and radiated spurious emission test data the worst mode was reported in this report.

Declaration of Conformity:
The test results with all measurement uncertainty excluded are presented in accordance with the regulation limits or requirements declared by manufacturers.
Comments and Explanations:
The declared of product specification for EUT presented in the report are provided by the manufacturer, and the manufacturer takes all the responsibilities for the accuracy of product specification.

Reviewed by: Wii Chang
Report Producer: Lucy Wu



1 General Description

1.1 Product Feature of Equipment Under Test

GSM/WCDMA/LTE, Bluetooth, DTS/UNII a/b/g/n/ac/ax, FM Receiver, NFC, and GNSS.

Standards-related Product Specification	
Antenna Type / Gain	<Ant. 0>: Loop Antenna with gain -1.80 dBi <Ant. 1>: Loop Antenna with gain -11.50 dBi

EUT Information List			
HW Version	SW Version	S/N	Performed Test Item
A	1.130	QV71004F3Z	RF conducted measurement
	1.130	QV71001L3Z	Radiated Spurious Emission

Accessory List	
AC Adapter	Model Name : UCH32
	S/N: 6218W30200005
Earphone	Model Name.: STH40D
	S/N : N/A
USB Cable	Model Name.: UCB 24
	S/N : N/A

Note:

1. Above EUT list used are electrically identical per declared by manufacturer.
2. Above the accessories list are used to exercise the EUT during test, and the serial number of each type of accessories is listed in each section of this report. .
3. For other wireless features of this EUT, test report will be issued separately.

1.2 Modification of EUT

No modifications are made to the EUT during all test items.



1.3 Testing Location

Test Site	SPORTON INTERNATIONAL INC. EMC & Wireless Communications Laboratory
Test Site Location	No.52, Huaya 1st Rd., Guishan Dist., Taoyuan City, Taiwan (R.O.C.) TEL: +886-3-327-3456 FAX: +886-3-328-4978
Test Site No.	Sporton Site No.
	TH05-HY

Test Site	SPORTON INTERNATIONAL INC. EMC & Wireless Communications Laboratory
Test Site Location	No.58, Aly. 75, Ln. 564, Wenhua 3rd, Rd., Guishan Dist., Taoyuan City, Taiwan (R.O.C.) TEL: +886-3-327-0868 FAX: +886-3-327-0855
Test Site No.	Sporton Site No.
	03CH12-HY

Note: The test site complies with ANSI C63.4 2014 requirement.

FCC designation No.: TW1190 and TW0007

1.4 Applicable Standards

According to the specifications of the manufacturer, the EUT must comply with the requirements of the following standards:

- ♦ FCC Part 15 Subpart C §15.247
- ♦ FCC KDB Publication No. 558074 D01 DTS Meas. Guidance v05r02
- ♦ FCC KDB 414788 D01 Radiated Test Site v01r01.
- ♦ FCC KDB 662911 D01 Multiple Transmitter Output v02r01.
- ♦ ANSI C63.10-2013

Remark:

1. All test items were verified and recorded according to the standards and without any deviation during the test.
2. The TAF code is not including all the FCC KDB listed without accreditation.
3. This EUT has also been tested and complied with the requirements of FCC Part 15, Subpart B, recorded in a separate test report.



2 Test Configuration of Equipment Under Test

- a. The EUT has been associated with peripherals and configuration operated in a manner tended to maximize its emission characteristics in a typical application. Frequency range investigated: radiation emission (9 kHz to the 10th harmonic of the highest fundamental frequency or to 40 GHz, whichever is lower). For radiated measurement, pre-scanned in three orthogonal panels, X, Y, Z. The worst cases (X plane) were recorded in this report.

2.1 Carrier Frequency and Channel

Frequency Band	Channel	Freq. (MHz)	Channel	Freq. (MHz)
2400-2483.5 MHz	1	2412	7	2442
	2	2417	8	2447
	3	2422	9	2452
	4	2427	10	2457
	5	2432	11	2462
	6	2437		

2.2 Test Mode

Final test modes are considering the modulation and worse data rates as below table.

Modulation	Data Rate
802.11b	1 Mbps
802.11g	6 Mbps
802.11n HT20	MCS0
802.11ax HE20	MCS0

Ch. #	2400-2483.5 MHz		
	802.11b	802.11n HT20	802.11ax HE20
Low	-	-	-
Middle	-	-	-
High	11	11	11

Remark: For radiation spurious emission, the final modulation and the worst data rate was reference the max RF conducted power.

2.3 Connection Diagram of Test System

<WLAN Tx Mode>

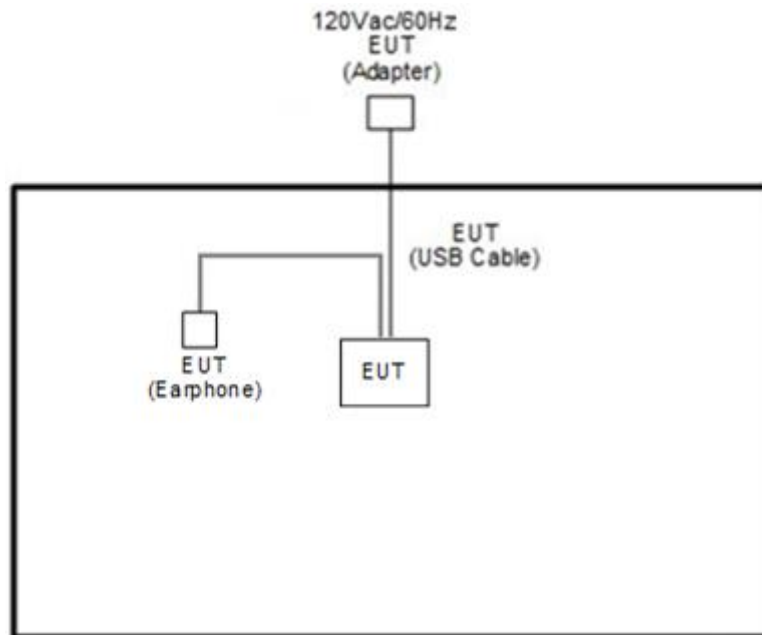

2.4 EUT Operation Test Setup

The RF test items, utility “FTM bridge V.0.39” was installed in Notebook which was programmed in order to make the EUT get into the engineering modes to provide channel selection, power level, data rate and the application type and for continuous transmitting signals.

3 Test Result

3.1 Output Power Measurement

3.1.1 Limit of Output Power

For systems using digital modulation in the 2400-2483.5MHz, the limit for output power is 30dBm. If transmitting antenna with directional gain greater than 6dBi is used, the peak output power from the intentional radiator shall be reduced below the above stated value by the amount in dB that the directional gain of the antenna exceeds 6 dBi. In case of point-to-point operation, the limit has to be reduced by 1dB for every 3dB that the directional gain of the antenna exceeds 6dBi.

3.1.2 Measuring Instruments

See list of measuring equipment of this test report.

3.1.3 Test Procedures

1. For Peak Power, the testing follows ANSI C63.10 Section 11.9.1.3 PKPM1
2. For Average Power, the testing follows ANSI C63.10 Section 11.9.2.3.2 Method AVGPM-G
3. The RF output of EUT was connected to the power meter by RF cable and attenuator. The path loss was compensated to the results for each measurement.
4. Set to the maximum power setting and enable the EUT transmit continuously.
5. Measure the conducted output power and record the results in the test report.
6. For MIMO mode, calculation method follows FCC KDB 662911 D01 Multiple Transmitter Output v02r01.

3.1.4 Test Setup

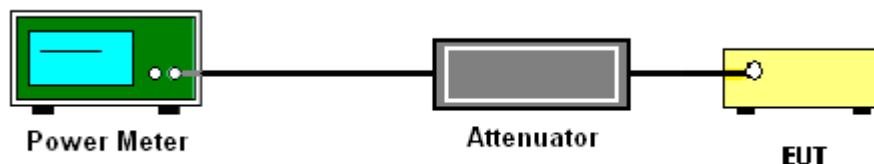

3.1.5 Test Result of Peak Output Power

Please refer to Appendix A.

3.1.6 Test Result of Average Output Power (Reporting Only)

Please refer to Appendix A.



3.2 Radiated Band Edges and Spurious Emission Measurement

3.2.1 Limit of Radiated band edge and Spurious Emission Measurement

In any 100 kHz bandwidth outside the intentional radiator frequency band, all harmonics/spurious must be at least 20 dB below the highest emission level within the authorized band. If the output power of this device was measured by spectrum analyzer, the attenuation under this paragraph shall be 30 dB instead of 20 dB. In addition, radiated emissions which fall in the restricted bands must also comply with the limits as below.

Frequency (MHz)	Field Strength (microvolts/meter)	Measurement Distance (meters)
0.009 – 0.490	2400/F(kHz)	300
0.490 – 1.705	24000/F(kHz)	30
1.705 – 30.0	30	30
30 – 88	100	3
88 – 216	150	3
216 - 960	200	3
Above 960	500	3

3.2.2 Measuring Instruments

See list of measuring equipment of this test report.



3.2.3 Test Procedures

1. The testing follows the ANSI C63.10 Section 11.12.1 Radiated emission measurements.
2. The EUT was arranged to its worst case and then tune the antenna tower (from 1 m to 4 m) and turntable (from 0 degree to 360 degrees) to find the maximum reading. A pre-amp and a high pass filter are used for the test in order to get better signal level.
3. The EUT was placed on a turntable with 0.8 meter for frequency below 1GHz and 1.5 meter for frequency above 1GHz respectively above ground.
4. The EUT was set 3 meters from the interference receiving antenna, which was mounted on the top of a variable height antenna tower.
5. Corrected Reading: Antenna Factor + Cable Loss + Read Level - Preamp Factor = Level
6. For testing below 1GHz, if the emission level of the EUT in peak mode was 3 dB lower than the limit specified, then peak values of EUT will be reported, otherwise, the emissions will be repeated one by one using the CISPR quasi-peak method and reported.
7. For testing above 1GHz, the emission level of the EUT in peak mode was 20dB lower than average limit (that means the emission level in average mode also complies with the limit in average mode), then peak values of EUT will be reported, otherwise, the emissions will be measured in average mode again and reported.
8. Use the following spectrum analyzer settings:
 - (1) Span shall wide enough to fully capture the emission being measured;
 - (2) Set RBW=100 kHz for $f < 1$ GHz; $VBW \geq RBW$; Sweep = auto; Detector function = peak; Trace = max hold;
 - (3) Set RBW = 1 MHz, VBW= 3MHz for $f \geq 1$ GHz for peak measurement.
For average measurement:
 - $VBW = 10$ Hz, when duty cycle is no less than 98 percent.
 - $VBW \geq 1/T$, when duty cycle is less than 98 percent where T is the minimum transmission duration over which the transmitter is on and is transmitting at its maximum power control level for the tested mode of operation.

3.2.4 Test Setup

For radiated emissions below 30MHz

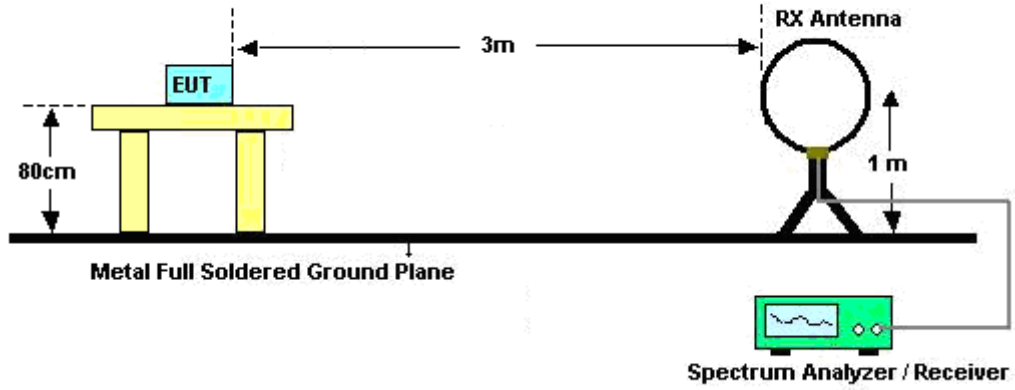

For radiated emissions from 30MHz to 1GHz

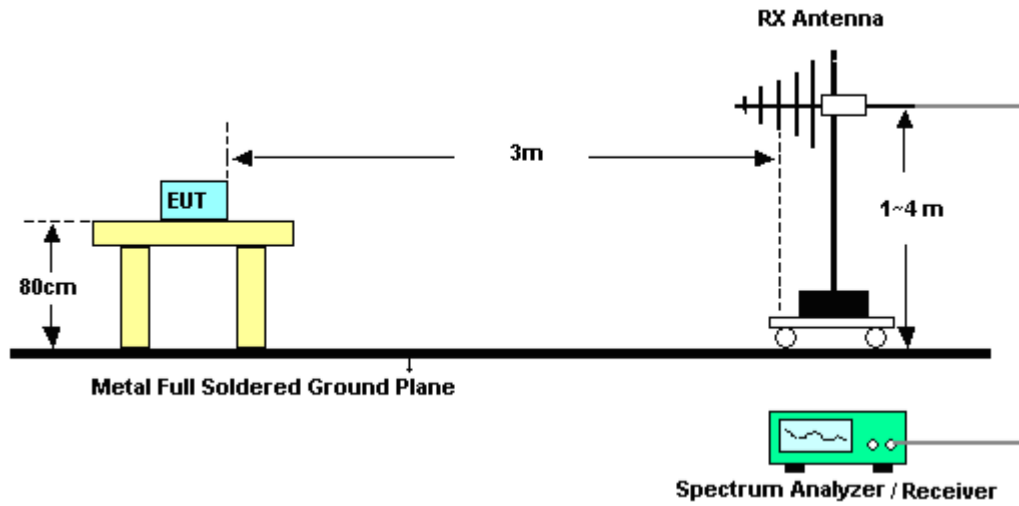

For radiated emissions from 1GHz to 18GHz

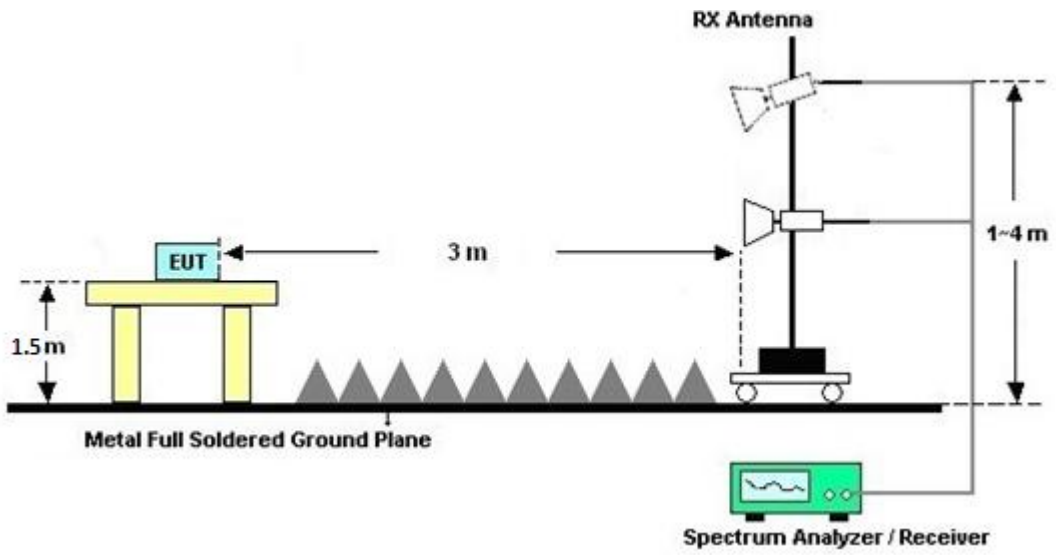

For radiated emissions above 18GHz

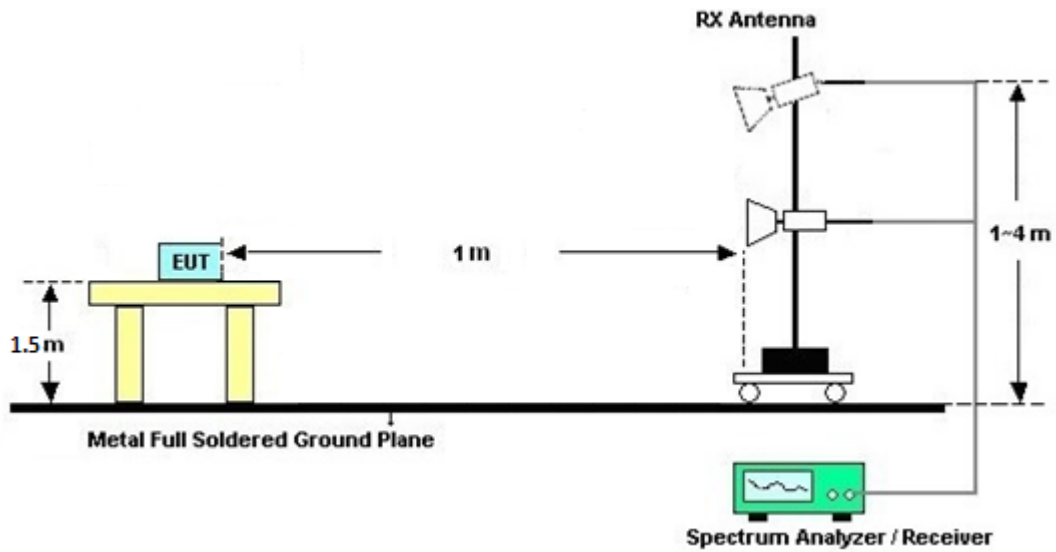



3.2.5 Test Results of Radiated Spurious Emissions (9kHz ~ 30MHz)

The low frequency, which started from 9 kHz to 30MHz, was pre-scanned and the result which was 20dB lower than the limit line was not reported.

There is a comparison data of both open-field test site and alternative test site - semi-Anechoic chamber according to 414788 D01 Radiated Test Site v01r01, and the result came out very similar.

3.2.6 Test Result of Radiated Spurious at Band Edges

Please refer to Appendix B and C.

3.2.7 Duty Cycle

Please refer to Appendix D.

3.2.8 Test Result of Radiated Spurious Emission (30MHz ~ 10th Harmonic)

Please refer to Appendix B and C.



3.3 Antenna Requirements

3.3.1 Standard Applicable

If directional gain of transmitting Antennas is greater than 6dBi, the power shall be reduced by the same level in dB comparing to gain minus 6dBi. The use of a permanently attached Antenna or of an Antenna that uses a unique coupling to the intentional radiator shall be considered sufficient to comply with the rule.

3.3.2 Antenna Anti-Replacement Construction

An embedded-in antenna design is used.

3.3.3 Antenna Gain

The antenna peak gain of EUT is less than 6 dBi. Therefore, it is not necessary to reduce maximum peak output power limit.



4 List of Measuring Equipment

Instrument	Brand Name	Model No.	Serial No.	Characteristics	Calibration Date	Test Date	Due Date	Remark
Hygrometer	Testo	608-H1	34893241	N/A	Mar. 02, 2020	Aug. 04, 2020~ Aug. 12, 2020	Mar. 01, 2021	Conducted (TH05-HY)
Power Sensor	DARE	RPR3006W	16I00054S NO10	10MHz~6GHz	Dec. 23, 2019	Aug. 04, 2020~ Aug. 12, 2020	Dec. 22, 2020	Conducted (TH05-HY)
Spectrum Analyzer	Rohde & Schwarz	FSV40	101397	10Hz~40GHz	Nov. 15, 2019	Aug. 04, 2020~ Aug. 12, 2020	Nov. 14, 2020	Conducted (TH05-HY)
Switch Box & RF Cable	Burgeon	ETF-058	EC130048 4	N/A	Aug. 22, 2019	Aug. 04, 2020~ Aug. 12, 2020	Aug. 21, 2020	Conducted (TH05-HY)
DC Power Supply	GW Instek	GPE2323	GEU81096 8	N/A	Jul. 30, 2020	Aug. 04, 2020~ Aug. 12, 2020	Jul. 29, 2021	Conducted (TH05-HY)
Power Meter	Agilent	E4416A	GB412923 44	N/A	Dec. 27, 2019	Aug. 04, 2020~ Aug. 12, 2020	Dec. 26, 2020	Conducted (TH05-HY)
Loop Antenna	Rohde & Schwarz	HFH2-Z2	100315	9 kHz~30 MHz	Dec. 26, 2019	Aug. 20, 2020~ Aug. 21, 2020	Dec. 25, 2020	Radiation (03CH12-HY)
Bilog Antenna	TESEQ	CBL 6111D & 00800N1D01N -06	37059 & 01	30MHz~1GHz	Oct. 12, 2019	Aug. 20, 2020~ Aug. 21, 2020	Oct. 11, 2020	Radiation (03CH12-HY)
Horn Antenna	SCHWARZBE CK	BBHA 9120 D	9120D-132 8	1GHz~18GHz	Nov. 14, 2019	Aug. 20, 2020~ Aug. 21, 2020	Nov. 13, 2020	Radiation (03CH12-HY)
SHF-EHF Horn Antenna	SCHWARZBE CK	BBHA 9170	BBHA9170 584	18GHz~40GHz	Dec. 10, 2019	Aug. 20, 2020~ Aug. 21, 2020	Dec. 09, 2020	Radiation (03CH12-HY)
Preamplifier	COM-POWER	PA-103	161075	10MHz~1GHz	Mar. 25, 2020	Aug. 20, 2020~ Aug. 21, 2020	Mar. 24, 2021	Radiation (03CH12-HY)
Preamplifier	Agilent	8449B	3008A0237 5	1GHz~26.5GHz	Mar. 26, 2020	Aug. 20, 2020~ Aug. 21, 2020	Mar. 25, 2021	Radiation (03CH12-HY)
Preamplifier	Jet-Power	JPA0118-55-3 03K	171000180 0054002	1GHz~18GHz	Feb. 07, 2020	Aug. 20, 2020~ Aug. 21, 2020	Feb. 06, 2021	Radiation (03CH12-HY)
Preamplifier	EMEC	EM18G40G	060715	18GHz~40GHz	Dec. 13, 2019	Aug. 20, 2020~ Aug. 21, 2020	Dec. 12, 2020	Radiation (03CH12-HY)
Spectrum Analyzer	Rohde & Schwarz	FSV40	101756	10Hz~40GHz	Dec. 24, 2019	Aug. 20, 2020~ Aug. 21, 2020	Dec. 23, 2020	Radiation (03CH12-HY)
RF Cable	HUBER + SUHNER	SUCOFLEX 126E	0058/126E	30MHz~18GHz	Dec. 12, 2019	Aug. 20, 2020~ Aug. 21, 2020	Dec. 11, 2020	Radiation (03CH12-HY)
RF Cable	HUBER + SUHNER	SUCOFLEX 102	505134/2	30MHz~40GHz	Feb. 25, 2020	Aug. 20, 2020~ Aug. 21, 2020	Feb. 24, 2021	Radiation (03CH12-HY)
RF Cable	HUBER + SUHNER	SUCOFLEX 102	800740/2	30MHz~40GHz	Feb. 25, 2020	Aug. 20, 2020~ Aug. 21, 2020	Feb. 24, 2021	Radiation (03CH12-HY)
Hygrometer	TECPEL	DTM-303B	TP140349	N/A	Oct. 25, 2019	Aug. 20, 2020~ Aug. 21, 2020	Oct. 24, 2020	Radiation (03CH12-HY)
Controller	EMEC	EM1000	N/A	Control Turn table & Ant Mast	N/A	Aug. 20, 2020~ Aug. 21, 2020	N/A	Radiation (03CH12-HY)
Antenna Mast	EMEC	AM-BS-4500-B	N/A	1m~4m	N/A	Aug. 20, 2020~ Aug. 21, 2020	N/A	Radiation (03CH12-HY)
Turn Table	EMEC	TT2000	N/A	0~360 Degree	N/A	Aug. 20, 2020~ Aug. 21, 2020	N/A	Radiation (03CH12-HY)
Software	Audix	E3 6.2009-8-24	RK-000989	N/A	N/A	Aug. 20, 2020~ Aug. 21, 2020	N/A	Radiation (03CH12-HY)



5 Uncertainty of Evaluation

Uncertainty of Radiated Emission Measurement (30 MHz ~ 1000 MHz)

Measuring Uncertainty for a Level of Confidence of 95% ($U = 2Uc(y)$)	4.9
---	-----

Uncertainty of Radiated Emission Measurement (1000 MHz ~ 18000 MHz)

Measuring Uncertainty for a Level of Confidence of 95% ($U = 2Uc(y)$)	5.6
---	-----

Uncertainty of Radiated Emission Measurement (18000 MHz ~ 40000 MHz)

Measuring Uncertainty for a Level of Confidence of 95% ($U = 2Uc(y)$)	4.9
---	-----

Appendix A. Test Result of Conducted Test Items

Test Engineer:	HaoHsiang Chang	Temperature:	23.5~24.3	°C
Test Date:	2020/08/04~2020/08/12	Relative Humidity:	49.0~53.9	%

TEST RESULTS DATA
Peak Output Power

2.4GHz Band Single Antenna																
Mod.	Data Rate	N _{TX}	CH.	Freq. (MHz)	Peak Conducted Power (dBm)			Conducted Power Limit (dBm)		DG (dBi)		EIRP Power (dBm)		EIRP Power Limit (dBm)		Pass /Fail
					Ant0	Ant1	SUM	Ant0	Ant1	Ant0	Ant1	Ant0	Ant1	Ant0	Ant1	
11b	1Mbps	1	1	2412	16.10	9.46		30.00	30.00	-1.80	-11.50	14.30	-2.04	36.00	36.00	Pass
11b	1Mbps	1	6	2437	16.21	9.55		30.00	30.00	-1.80	-11.50	14.41	-1.95	36.00	36.00	Pass
11b	1Mbps	1	11	2462	16.12	9.41		30.00	30.00	-1.80	-11.50	14.32	-2.09	36.00	36.00	Pass
11g	6Mbps	1	1	2412	19.04	20.14		30.00	30.00	-1.80	-11.50	17.24	8.64	36.00	36.00	Pass
11g	6Mbps	1	6	2437	21.06	22.74		30.00	30.00	-1.80	-11.50	19.26	11.24	36.00	36.00	Pass
11g	6Mbps	1	11	2462	20.92	22.91		30.00	30.00	-1.80	-11.50	19.12	11.41	36.00	36.00	Pass
HT20	MCS0	1	1	2412	19.14	20.08		30.00	30.00	-1.80	-11.50	17.34	8.58	36.00	36.00	Pass
HT20	MCS0	1	6	2437	20.82	22.70		30.00	30.00	-1.80	-11.50	19.02	11.20	36.00	36.00	Pass
HT20	MCS0	1	11	2462	21.02	22.85		30.00	30.00	-1.80	-11.50	19.22	11.35	36.00	36.00	Pass

2.4GHz Band MIMO																
Mod.	Data Rate	N _{TX}	CH.	Freq. (MHz)	Peak Conducted Power (dBm)			Conducted Power Limit (dBm)		DG (dBi)		EIRP Power (dBm)		EIRP Power Limit (dBm)		Pass /Fail
					Ant0	Ant1	SUM	Ant0	Ant1	Ant0	Ant1	Ant0	Ant1	Ant0	Ant1	
11b	1Mbps	2	1	2412	16.21	9.55	17.06	30.00		-1.80		15.26		36.00		Pass
11b	1Mbps	2	6	2437	16.28	9.62	17.13	30.00		-1.80		15.33		36.00		Pass
11b	1Mbps	2	11	2462	16.32	9.51	17.14	30.00		-1.80		15.34		36.00		Pass
11g	6Mbps	2	1	2412	19.06	20.36	22.77	30.00		-1.80		20.97		36.00		Pass
11g	6Mbps	2	6	2437	21.08	22.87	25.08	30.00		-1.80		23.28		36.00		Pass
11g	6Mbps	2	11	2462	20.99	22.93	25.08	30.00		-1.80		23.28		36.00		Pass
HT20	MCS0	2	1	2412	19.52	20.29	22.93	30.00		-1.80		21.13		36.00		Pass
HT20	MCS0	2	6	2437	20.83	22.82	24.95	30.00		-1.80		23.15		36.00		Pass
HT20	MCS0	2	11	2462	21.06	23.01	25.15	30.00		-1.80		23.35		36.00		Pass

Note: Measured power (dBm) has offset with cable loss.

TEST RESULTS DATA
Average Output Power

2.4GHz Band Single Antenna																
Mod.	Data Rate	NTX	CH.	Freq. (MHz)	Average Conducted Power with duty factor (dBm)			Conducted Power Limit (dBm)		DG (dBi)		EIRP Power (dBm)		EIRP Power Limit (dBm)		Pass /Fail
					Ant0	Ant1	SUM	Ant0	Ant1	Ant0	Ant1	Ant0	Ant1	Ant0	Ant1	
11b	1Mbps	1	1	2412	13.58	6.65		30.00	30.00	-1.80	-11.50	11.78	-4.85	36.00	36.00	Pass
11b	1Mbps	1	6	2437	13.63	6.66		30.00	30.00	-1.80	-11.50	11.83	-4.84	36.00	36.00	Pass
11b	1Mbps	1	11	2462	13.58	6.52		30.00	30.00	-1.80	-11.50	11.78	-4.98	36.00	36.00	Pass
11g	6Mbps	1	1	2412	11.68	12.86		30.00	30.00	-1.80	-11.50	9.88	1.36	36.00	36.00	Pass
11g	6Mbps	1	6	2437	13.73	15.74		30.00	30.00	-1.80	-11.50	11.93	4.24	36.00	36.00	Pass
11g	6Mbps	1	11	2462	13.88	15.69		30.00	30.00	-1.80	-11.50	12.08	4.19	36.00	36.00	Pass
HT20	MCS0	1	1	2412	11.59	12.62		30.00	30.00	-1.80	-11.50	9.79	1.12	36.00	36.00	Pass
HT20	MCS0	1	6	2437	13.55	15.49		30.00	30.00	-1.80	-11.50	11.75	3.99	36.00	36.00	Pass
HT20	MCS0	1	11	2462	13.70	15.59		30.00	30.00	-1.80	-11.50	11.90	4.09	36.00	36.00	Pass

2.4GHz Band MIMO																
Mod.	Data Rate	NTX	CH.	Freq. (MHz)	Average Conducted Power with duty factor (dBm)			Conducted Power Limit (dBm)		DG (dBi)		EIRP Power (dBm)		EIRP Power Limit (dBm)		Pass /Fail
					Ant0	Ant1	SUM	Ant0	Ant1	Ant0	Ant1	Ant0	Ant1	Ant0	Ant1	
11b	1Mbps	2	1	2412	13.65	6.70	14.45	30.00		-1.80		12.65		36.00		Pass
11b	1Mbps	2	6	2437	13.67	6.81	14.48	30.00		-1.80		12.68		36.00		Pass
11b	1Mbps	2	11	2462	13.79	6.59	14.55	30.00		-1.80		12.75		36.00		Pass
11g	6Mbps	2	1	2412	11.69	12.94	15.37	30.00		-1.80		13.57		36.00		Pass
11g	6Mbps	2	6	2437	13.75	15.80	17.91	30.00		-1.80		16.11		36.00		Pass
11g	6Mbps	2	11	2462	13.90	15.76	17.94	30.00		-1.80		16.14		36.00		Pass
HT20	MCS0	2	1	2412	11.92	12.70	15.34	30.00		-1.80		13.54		36.00		Pass
HT20	MCS0	2	6	2437	13.56	15.50	17.65	30.00		-1.80		15.85		36.00		Pass
HT20	MCS0	2	11	2462	13.79	15.60	17.80	30.00		-1.80		16.00		36.00		Pass

Note: Measured power (dBm) has offset with cable loss.

TEST RESULTS DATA
Peak Output Power

2.4GHz Band Single Antenna																	
Mod.	Data Rate	Ntx	CH.	Freq. (MHz)	RU Config.	Peak Conducted Power (dBm)			Conducted Power Limit (dBm)		DG (dBi)		EIRP Power (dBm)		EIRP Power Limit (dBm)		Pass /Fail
						Ant0	Ant1	SUM	Ant0	Ant1	Ant0	Ant1	Ant0	Ant1	Ant0	Ant1	
HE20	MCS0	1	1	2412	Full	20.96	21.07		30.00	30.00	-1.80	-11.50	19.16	9.57	36.00	36.00	Pass
HE20	MCS0	1	1	2412	26/0	20.79	19.70		30.00	30.00	-1.80	-11.50	18.99	8.20	36.00	36.00	Pass
HE20	MCS0	1	1	2412	52/37	23.36	22.52		30.00	30.00	-1.80	-11.50	21.56	11.02	36.00	36.00	Pass
HE20	MCS0	1	1	2412	106/53	24.18	23.32		30.00	30.00	-1.80	-11.50	22.38	11.82	36.00	36.00	Pass
HE20	MCS0	1	6	2437	Full	22.65	23.46		30.00	30.00	-1.80	-11.50	20.85	11.96	36.00	36.00	Pass
HE20	MCS0	1	6	2437	26/4	19.49	19.10		30.00	30.00	-1.80	-11.50	17.69	7.60	36.00	36.00	Pass
HE20	MCS0	1	6	2437	52/38	22.70	22.28		30.00	30.00	-1.80	-11.50	20.90	10.78	36.00	36.00	Pass
HE20	MCS0	1	6	2437	106/53	23.88	23.09		30.00	30.00	-1.80	-11.50	22.08	11.59	36.00	36.00	Pass
HE20	MCS0	1	11	2462	Full	21.90	23.59		30.00	30.00	-1.80	-11.50	20.10	12.09	36.00	36.00	Pass
HE20	MCS0	1	11	2462	26/8	20.06	19.45		30.00	30.00	-1.80	-11.50	18.26	7.95	36.00	36.00	Pass
HE20	MCS0	1	11	2462	52/40	22.67	22.06		30.00	30.00	-1.80	-11.50	20.87	10.56	36.00	36.00	Pass
HE20	MCS0	1	11	2462	106/54	21.85	23.38		30.00	30.00	-1.80	-11.50	20.05	11.88	36.00	36.00	Pass

2.4GHz Band MIMO																	
Mod.	Data Rate	Ntx	CH.	Freq. (MHz)	RU Config.	Peak Conducted Power (dBm)			Conducted Power Limit (dBm)		DG (dBi)		EIRP Power (dBm)		EIRP Power Limit (dBm)		Pass /Fail
						Ant0	Ant1	SUM	Ant0	Ant1	Ant0	Ant1	Ant0	Ant1	Ant0	Ant1	
HE20	MCS0	2	1	2412	Full	21.03	21.17	24.11	30.00		-1.80		22.31		36.00		Pass
HE20	MCS0	2	1	2412	26/0	20.86	19.73	23.34	30.00		-1.80		21.54		36.00		Pass
HE20	MCS0	2	1	2412	52/37	23.52	22.58	26.09	30.00		-1.80		24.29		36.00		Pass
HE20	MCS0	2	1	2412	106/53	24.27	23.39	26.86	30.00		-1.80		25.06		36.00		Pass
HE20	MCS0	2	6	2437	Full	22.67	23.50	26.12	30.00		-1.80		24.32		36.00		Pass
HE20	MCS0	2	6	2437	26/4	19.50	19.21	22.37	30.00		-1.80		20.57		36.00		Pass
HE20	MCS0	2	6	2437	52/38	22.77	22.52	25.66	30.00		-1.80		23.86		36.00		Pass
HE20	MCS0	2	6	2437	106/53	23.90	23.12	26.54	30.00		-1.80		24.74		36.00		Pass
HE20	MCS0	2	11	2462	Full	21.95	23.61	25.87	30.00		-1.80		24.07		36.00		Pass
HE20	MCS0	2	11	2462	26/8	20.16	19.49	22.85	30.00		-1.80		21.05		36.00		Pass
HE20	MCS0	2	11	2462	52/40	22.69	22.10	25.42	30.00		-1.80		23.62		36.00		Pass
HE20	MCS0	2	11	2462	106/54	21.90	23.39	25.72	30.00		-1.80		23.92		36.00		Pass

Note: Measured power (dBm) has offset with cable loss.

TEST RESULTS DATA
Average Output Power

2.4GHz Band Single Antenna																	
Mod.	Data Rate	Ntx	CH.	Freq. (MHz)	RU Config.	Average Conducted Power with duty factor (dBm)			Conducted Power Limit (dBm)		DG (dBi)		EIRP Power (dBm)		EIRP Power Limit (dBm)		Pass /Fail
						Ant0	Ant1	SUM	Ant0	Ant1	Ant0	Ant1	Ant0	Ant1	Ant0	Ant1	
HE20	MCS0	1	1	2412	Full	12.54	12.72		30.00	30.00	-1.80	-11.50	10.74	1.22	36.00	36.00	Pass
HE20	MCS0	1	1	2412	26/0	9.00	8.77		30.00	30.00	-1.80	-11.50	7.20	-2.73	36.00	36.00	Pass
HE20	MCS0	1	1	2412	52/37	12.26	11.86		30.00	30.00	-1.80	-11.50	10.46	0.36	36.00	36.00	Pass
HE20	MCS0	1	1	2412	106/53	13.89	13.53		30.00	30.00	-1.80	-11.50	12.09	2.03	36.00	36.00	Pass
HE20	MCS0	1	6	2437	Full	14.70	15.65		30.00	30.00	-1.80	-11.50	12.90	4.15	36.00	36.00	Pass
HE20	MCS0	1	6	2437	26/4	8.93	9.11		30.00	30.00	-1.80	-11.50	7.13	-2.39	36.00	36.00	Pass
HE20	MCS0	1	6	2437	52/38	12.30	11.97		30.00	30.00	-1.80	-11.50	10.50	0.47	36.00	36.00	Pass
HE20	MCS0	1	6	2437	106/53	13.93	13.33		30.00	30.00	-1.80	-11.50	12.13	1.83	36.00	36.00	Pass
HE20	MCS0	1	11	2462	Full	13.89	15.62		30.00	30.00	-1.80	-11.50	12.09	4.12	36.00	36.00	Pass
HE20	MCS0	1	11	2462	26/8	9.21	9.22		30.00	30.00	-1.80	-11.50	7.41	-2.28	36.00	36.00	Pass
HE20	MCS0	1	11	2462	52/40	12.22	12.29		30.00	30.00	-1.80	-11.50	10.42	0.79	36.00	36.00	Pass
HE20	MCS0	1	11	2462	106/54	14.23	13.44		30.00	30.00	-1.80	-11.50	12.43	1.94	36.00	36.00	Pass

2.4GHz Band MIMO																	
Mod.	Data Rate	Ntx	CH.	Freq. (MHz)	RU Config.	Average Conducted Power with duty factor (dBm)			Conducted Power Limit (dBm)		DG (dBi)		EIRP Power (dBm)		EIRP Power Limit (dBm)		Pass /Fail
						Ant0	Ant1	SUM	Ant0	Ant1	Ant0	Ant1	Ant0	Ant1	Ant0	Ant1	
HE20	MCS0	2	1	2412	Full	12.65	12.80	15.74	30.00		-1.80		13.94		36.00		Pass
HE20	MCS0	2	1	2412	26/0	9.02	8.99	12.02	30.00		-1.80		10.22		36.00		Pass
HE20	MCS0	2	1	2412	52/37	12.27	11.90	15.10	30.00		-1.80		13.30		36.00		Pass
HE20	MCS0	2	1	2412	106/53	13.92	13.95	16.95	30.00		-1.80		15.15		36.00		Pass
HE20	MCS0	2	6	2437	Full	14.76	15.72	18.28	30.00		-1.80		16.48		36.00		Pass
HE20	MCS0	2	6	2437	26/4	8.95	9.32	12.15	30.00		-1.80		10.35		36.00		Pass
HE20	MCS0	2	6	2437	52/38	12.32	12.17	15.26	30.00		-1.80		13.46		36.00		Pass
HE20	MCS0	2	6	2437	106/53	13.95	13.52	16.75	30.00		-1.80		14.95		36.00		Pass
HE20	MCS0	2	11	2462	Full	13.90	15.63	17.86	30.00		-1.80		16.06		36.00		Pass
HE20	MCS0	2	11	2462	26/8	9.43	9.30	12.38	30.00		-1.80		10.58		36.00		Pass
HE20	MCS0	2	11	2462	52/40	12.28	12.36	15.33	30.00		-1.80		13.53		36.00		Pass
HE20	MCS0	2	11	2462	106/54	14.26	13.64	16.97	30.00		-1.80		15.17		36.00		Pass

Note: Measured power (dBm) has offset with cable loss.



Appendix B. Radiated Spurious Emission

Test Engineer :	Jack Cheng, Lance Chiang and Chuan Chu	Temperature :	23.8~26.2°C
		Relative Humidity :	56.5~68.6%

2.4GHz 2400~2483.5MHz

WIFI 802.11b (Band Edge @ 3m)

WIFI	Note	Frequency	Level	Over	Limit	Read	Antenna	Path	Preamp	Ant	Table	Peak	Pol.
Ant.				Limit	Line	Level	Factor	Loss	Factor	Pos	Pos	Avg.	
0+1		(MHz)	(dBμV/m)	(dB)	(dBμV/m)	(dBμV)	(dB/m)	(dB)	(dB)	(cm)	(deg)	(P/A)	(H/V)
802.11b CH 11 2462MHz	*	2462	99.2	-	-	89.97	27.38	15.95	34.1	116	323	P	H
	*	2462	95.72	-	-	86.49	27.38	15.95	34.1	116	323	A	H
		2496.12	54.52	-19.48	74	45.29	27.31	16	34.08	116	323	P	H
		2483.6	39.32	-14.68	54	30.1	27.33	15.98	34.09	116	323	A	H
													H
													H
	*	2462	98.08	-	-	88.85	27.38	15.95	34.1	102	127	P	V
	*	2462	94.52	-	-	85.29	27.38	15.95	34.1	102	127	A	V
		2483.92	54.32	-19.68	74	45.1	27.33	15.98	34.09	102	127	P	V
		2486	39.2	-14.8	54	29.97	27.33	15.99	34.09	102	127	A	V
													V
												V	
Remark	1. No other spurious found. 2. All results are PASS against Peak and Average limit line.												



**2.4GHz 2400~2483.5MHz
WIFI 802.11b (Harmonic @ 3m)**

WIFI Ant. 0+1	Note	Frequency (MHz)	Level (dBμV/m)	Over Limit (dB)	Limit Line (dBμV/m)	Read Level (dBμV)	Antenna Factor (dB/m)	Path Loss (dB)	Preamp Factor (dB)	Ant Pos (cm)	Table Pos (deg)	Peak Avg. (P/A)	Pol. (H/V)	
802.11b CH 11 2462MHz		4924	40.99	-33.01	74	60.22	31.15	9.98	60.36	100	0	P	H	
		7386	45.05	-28.95	74	54.97	36.43	12.72	59.07	100	0	P	H	
													H	
													H	
			4924	41.32	-32.68	74	60.55	31.15	9.98	60.36	100	0	P	V
			7386	45.97	-28.03	74	55.89	36.43	12.72	59.07	100	0	P	V
														V
														V
Remark	1. No other spurious found. 2. All results are PASS against Peak and Average limit line.													



**2.4GHz 2400~2483.5MHz
WIFI 802.11n HT20 (Band Edge @ 3m)**

WIFI Ant. 0+1	Note	Frequency (MHz)	Level (dBμV/m)	Over Limit (dB)	Limit Line (dBμV/m)	Read Level (dBμV)	Antenna Factor (dB/m)	Path Loss (dB)	Preamp Factor (dB)	Ant Pos (cm)	Table Pos (deg)	Peak Avg. (P/A)	Pol. (H/V)
802.11n HT20 CH 11 2462MHz	*	2462	105.59	-	-	96.36	27.38	15.95	34.1	118	354	P	H
	*	2462	95.63	-	-	86.4	27.38	15.95	34.1	118	354	A	H
		2484.2	57.12	-16.88	74	47.9	27.33	15.98	34.09	118	354	P	H
		2483.52	41.89	-12.11	54	32.67	27.33	15.98	34.09	118	354	A	H
													H
													H
	*	2462	99.59	-	-	90.36	27.38	15.95	34.1	100	129	P	V
	*	2462	88.85	-	-	79.62	27.38	15.95	34.1	100	129	A	V
		2485.16	54.56	-19.44	74	45.34	27.33	15.98	34.09	100	129	P	V
		2483.52	39.79	-14.21	54	30.57	27.33	15.98	34.09	100	129	A	V
												V	
												V	
Remark	1. No other spurious found. 2. All results are PASS against Peak and Average limit line.												



2.4GHz 2400~2483.5MHz
WIFI 802.11n HT20 (Harmonic @ 3m)

Table with 14 columns: WIFI Ant. 0+1, Note, Frequency (MHz), Level (dBµV/m), Over Limit (dB), Limit Line (dBµV/m), Read Level (dBµV), Antenna Factor (dB/m), Path Loss (dB), Preamp Factor (dB), Ant Pos (cm), Table Pos (deg), Peak Avg. (P/A), Pol. (H/V). Rows include data for 802.11n HT20 CH 11 at 4924 and 7386 MHz, and a Remark section.



2.4GHz 2400~2483.5MHz

WIFI 802.11 ax HE20 Full (Band Edge @ 3m)

WIFI Ant. 0+1	Note	Frequency (MHz)	Level (dBμV/m)	Over Limit (dB)	Limit Line (dBμV/m)	Read Level (dBμV)	Antenna Factor (dB/m)	Path Loss (dB)	Preamp Factor (dB)	Ant Pos (cm)	Table Pos (deg)	Peak Avg. (P/A)	Pol. (H/V)	
8802.11ax HE20 Full CH 11 2462MHz	*	2462	105.7	-	-	96.47	27.38	15.95	34.1	141	335	P	H	
	*	2462	96	-	-	86.77	27.38	15.95	34.1	141	335	A	H	
		2483.88	55.39	-18.61	74	46.17	27.33	15.98	34.09	141	335	P	H	
		2483.52	45.2	-8.8	54	35.98	27.33	15.98	34.09	141	335	A	H	
													H	
														H
	*	2462	99.02	-	-	89.79	27.38	15.95	34.1	111	93	P	V	
	*	2462	88.54	-	-	79.31	27.38	15.95	34.1	111	93	A	V	
		2485.88	52.62	-21.38	74	43.39	27.33	15.99	34.09	111	93	P	V	
		2483.52	41.97	-12.03	54	32.75	27.33	15.98	34.09	111	93	A	V	
													V	
													V	
Remark	1. No other spurious found. 2. All results are PASS against Peak and Average limit line.													



2.4GHz 2400~2483.5MHz

WIFI 802.11 ax HE20 Full (Harmonic @ 3m)

WIFI Ant. 0+1	Note	Frequency (MHz)	Level (dBμV/m)	Over Limit (dB)	Limit Line (dBμV/m)	Read Level (dBμV)	Antenna Factor (dB/m)	Path Loss (dB)	Preamp Factor (dB)	Ant Pos (cm)	Table Pos (deg)	Peak Avg. (P/A)	Pol. (H/V)	
802.11ax HE20 Full CH 11 2462MHz		4924	42.5	-31.5	74	61.73	31.15	9.98	60.36	100	0	P	H	
		7386	45.64	-28.36	74	55.56	36.43	12.72	59.07	100	0	P	H	
													H	
													H	
			4924	41.31	-32.69	74	60.54	31.15	9.98	60.36	100	0	P	V
			7386	44.76	-29.24	74	54.68	36.43	12.72	59.07	100	0	P	V
														V
													V	
Remark	1. No other spurious found. 2. All results are PASS against Peak and Average limit line.													



**Emission above 18GHz
2.4GHz WIFI 802.11n HT20 (SHF)**

WIFI	Note	Frequency	Level	Over	Limit	Read	Antenna	Path	Preamp	Ant	Table	Peak	Pol.	
Ant.				Limit	Line	Level	Factor	Loss	Factor	Pos	Pos	Avg.		
0+1		(MHz)	(dBμV/m)	(dB)	(dBμV/m)	(dBμV)	(dB/m)	(dB)	(dB)	(cm)	(deg)	(P/A)	(H/V)	
2.4GHz 802.11n HT20 SHF		23467	42	-32	74	49.9	39.62	5.8	53.32	150	0	P	H	
													H	
													H	
													H	
													H	
													H	
														H
														H
			23474	41.42	-32.58	74	49.3	39.64	5.8	53.32	150	0	P	V
														V
														V
														V
														V
														V
Remark	1. No other spurious found. 2. All results are PASS against limit line.													

Emission below 1GHz
2.4GHz WIFI 802.11n HT20 (LF)

WIFI	Note	Frequency	Level	Over	Limit	Read	Antenna	Path	Preamp	Ant	Table	Peak	Pol.	
Ant.				Limit	Line	Level	Factor	Loss	Factor	Pos	Pos	Avg.		
0+1		(MHz)	(dB μ V/m)	(dB)	(dB μ V/m)	(dB μ V)	(dB/m)	(dB)	(dB)	(cm)	(deg)	(P/A)	(H/V)	
2.4GHz 802.11n HT20 LF		47.46	29.9	-10.1	40	43.72	15.24	0.57	29.63	-	-	P	H	
		104.69	26.65	-16.85	43.5	38.93	16.37	0.97	29.62	-	-	P	H	
		177.44	34.73	-8.77	43.5	47.93	15	1.34	29.54	100	0	P	H	
		466.5	32.13	-13.87	46	35.45	23.39	2.35	29.06	-	-	P	H	
		719.67	36.47	-9.53	46	35.14	26.89	3.01	28.57	-	-	P	H	
		885.54	37.06	-8.94	46	32.59	29.03	3.69	28.25	-	-	P	H	
														H
														H
														H
														H
														H
														H
			41.64	33.53	-6.47	40	44.11	18.54	0.53	29.65	100	0	P	V
			79.47	30.41	-9.59	40	46.02	13.16	0.89	29.66	-	-	P	V
			103.72	25.74	-17.76	43.5	38.16	16.24	0.96	29.62	-	-	P	V
			488.81	35.56	-10.44	46	38.51	23.69	2.37	29.01	-	-	P	V
			643.04	31.4	-14.6	46	31.04	26.39	2.74	28.77	-	-	P	V
			821.52	34.36	-11.64	46	31.4	28	3.4	28.44	-	-	P	V
													V	
													V	
													V	
													V	
													V	
													V	
													V	

Remark

- No other spurious found.
- All results are PASS against limit line.



Note symbol

*	Fundamental Frequency which can be ignored. However, the level of any unwanted emissions shall not exceed the level of the fundamental frequency.
!	Test result is over limit line.
P/A	Peak or Average
H/V	Horizontal or Vertical



A calculation example for radiated spurious emission is shown as below:

WIFI	Note	Frequency	Level	Over	Limit	Read	Antenna	Path	Preamp	Ant	Table	Peak	Pol.
Ant.				Limit	Line	Level	Factor	Loss	Factor	Pos	Pos	Avg.	
0+1		(MHz)	(dBμV/m)	(dB)	(dBμV/m)	(dBμV)	(dB/m)	(dB)	(dB)	(cm)	(deg)	(P/A)	(H/V)
802.11b		2390	55.45	-18.55	74	54.51	32.22	4.58	35.86	103	308	P	H
CH 01													
2412MHz		2390	43.54	-10.46	54	42.6	32.22	4.58	35.86	103	308	A	H

1. Path Loss(dB) = Cable loss(dB) + Filter loss(dB) + Attenuator loss(dB)
2. Level(dBμV/m) =
Antenna Factor(dB/m) + Path Loss(dB) + Read Level(dBμV) - Preamp Factor(dB)
3. Over Limit(dB) = Level(dBμV/m) – Limit Line(dBμV/m)

For Peak Limit @ 2390MHz:

1. Level(dBμV/m)
= Antenna Factor(dB/m) + Path Loss(dB) + Read Level(dBμV) - Preamp Factor(dB)
= 32.22(dB/m) + 4.58(dB) + 54.51(dBμV) – 35.86 (dB)
= 55.45 (dBμV/m)
2. Over Limit(dB)
= Level(dBμV/m) – Limit Line(dBμV/m)
= 55.45(dBμV/m) – 74(dBμV/m)
= -18.55(dB)

For Average Limit @ 2390MHz:

1. Level(dBμV/m)
= Antenna Factor(dB/m) + Path Loss(dB) + Read Level(dBμV) - Preamp Factor(dB)
= 32.22(dB/m) + 4.58(dB) + 42.6(dBμV) – 35.86 (dB)
= 43.54 (dBμV/m)
2. Over Limit(dB)
= Level(dBμV/m) – Limit Line(dBμV/m)
= 43.54(dBμV/m) – 54(dBμV/m)
= -10.46(dB)

Both peak and average measured complies with the limit line, so test result is “PASS”.



Appendix C. Radiated Spurious Emission Plots

Test Engineer :	Jack Cheng, Lance Chiang and Chuan Chu	Temperature :	23.8~26.2°C
		Relative Humidity :	56.5~68.6%

Note symbol

-L	Low channel location
-R	High channel location

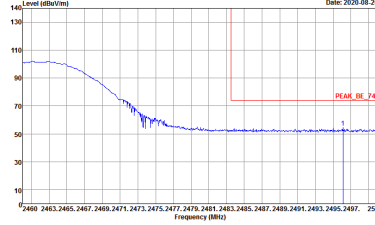
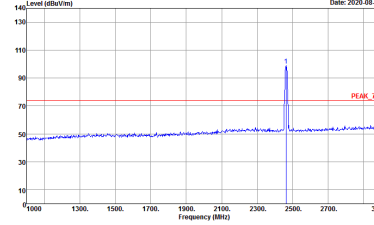
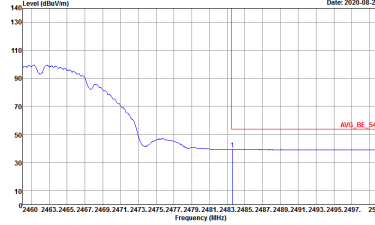
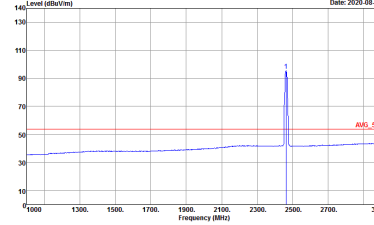

WIFI	2.4GHz 2400~2483.5MHz Band Edge @ 3m	
ANT	802.11b CH11 2462MHz	
0+1	Horizontal	Fundamental
Peak	 <p>Site : 03CH12-1FV Condition : PEAK_BE_74 3m HORN_9120D_1328 HORIZONTAL : RBW:1000.000kHz VBW:3000.000kHz SWT:Auto</p>	 <p>Site : 03CH12-1FV Condition : PEAK_T4 3m HORN_9120D_1328 HORIZONTAL : RBW:1000.000kHz VBW:3000.000kHz SWT:Auto</p>
Avg.	 <p>Site : 03CH12-1FV Condition : AVG_BE_54 3m HORN_9120D_1328 HORIZONTAL : RBW:1000.000kHz VBW:10.000kHz SWT:Auto</p>	 <p>Site : 03CH12-1FV Condition : AVG_54 3m HORN_9120D_1328 HORIZONTAL : RBW:1000.000kHz VBW:10.000kHz SWT:Auto</p>

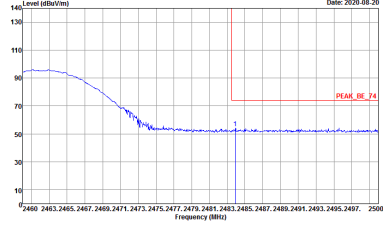
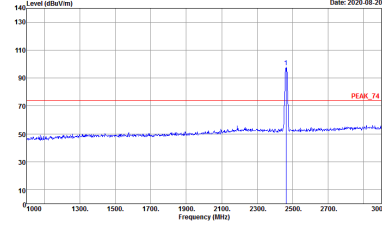
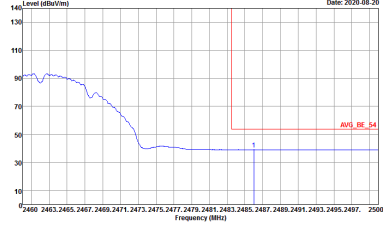
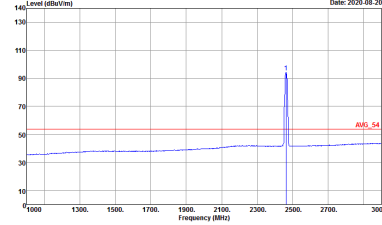

WIFI	2.4GHz 2400~2483.5MHz Band Edge @ 3m	
ANT	802.11b CH11 2462MHz	
0+1	Vertical	Fundamental
Peak	 <p>Site : 03CH12-11Y Condition : PEAK_BE_74 3m HORN_9120D_1328 VERTICAL : RBW:1000.000kHz VBW:3000.000kHz SWT:Auto</p>	 <p>Site : 03CH12-11Y Condition : PEAK_74 3m HORN_9120D_1328 VERTICAL : RBW:1000.000kHz VBW:3000.000kHz SWT:Auto</p>
Avg.	 <p>Site : 03CH12-11Y Condition : AVG_BE_54 3m HORN_9120D_1328 VERTICAL : RBW:1000.000kHz VBW:10.000kHz SWT:Auto</p>	 <p>Site : 03CH12-11Y Condition : AVG_54 3m HORN_9120D_1328 VERTICAL : RBW:1000.000kHz VBW:10.000kHz SWT:Auto</p>

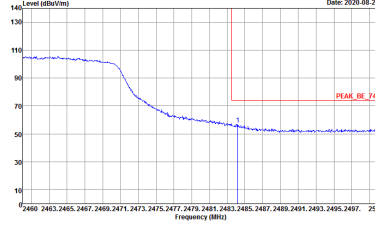
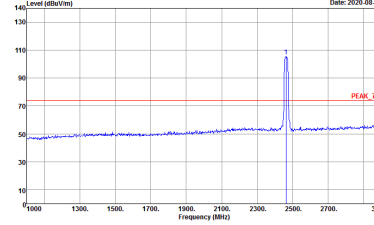
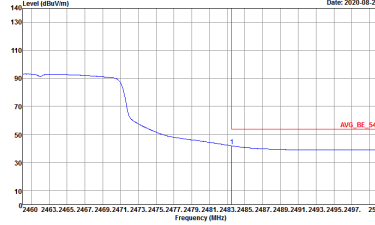
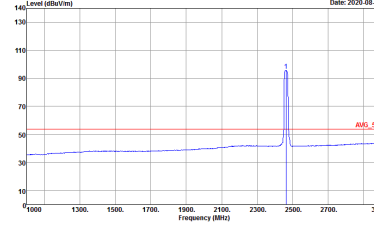

WIFI	2.4GHz 2400~2483.5MHz Band Edge @ 3m	
ANT	802.11n HT20 CH11 2462MHz	
0+1	Horizontal	Fundamental
Peak	 <p>Site : 03CH12-1FV Condition : PEAK_BE_74 3m HORN_9120D_1328 HORIZONTAL : RBW:1000.000kHz VBW:3000.000kHz SWT:Auto</p>	 <p>Site : 03CH12-1FV Condition : PEAK_T4 3m HORN_9120D_1328 HORIZONTAL : RBW:1000.000kHz VBW:3000.000kHz SWT:Auto</p>
Avg.	 <p>Site : 03CH12-1FV Condition : AVG_BE_54 3m HORN_9120D_1328 HORIZONTAL : RBW:1000.000kHz VBW:10.000kHz SWT:Auto</p>	 <p>Site : 03CH12-1FV Condition : AVG_54 3m HORN_9120D_1328 HORIZONTAL : RBW:1000.000kHz VBW:10.000kHz SWT:Auto</p>



WIFI	2.4GHz 2400~2483.5MHz Fundamental @ 3m	
ANT	802.11n HT20 CH11 2462MHz	
0+1	Vertical	Fundamental
Peak	<p>Site : 03CH12-11Y Condition : PEAK_BE_74 3m HORN_9120D_1328 VERTICAL : RBW:1000.000kHz VBW:3000.000kHz SWT:Auto</p>	<p>Site : 03CH12-11Y Condition : PEAK_T4 3m HORN_9120D_1328 VERTICAL : RBW:1000.000kHz VBW:3000.000kHz SWT:Auto</p>
Avg.	<p>Site : 03CH12-11Y Condition : AVG_BE_54 3m HORN_9120D_1328 VERTICAL : RBW:1000.000kHz VBW:10.000kHz SWT:Auto</p>	<p>Site : 03CH12-11Y Condition : AVG_S4 3m HORN_9120D_1328 VERTICAL : RBW:1000.000kHz VBW:10.000kHz SWT:Auto</p>

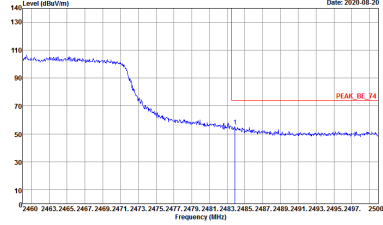
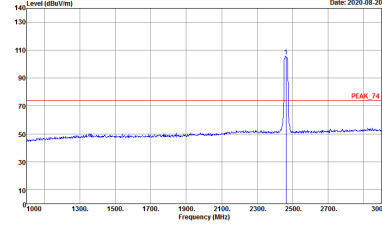
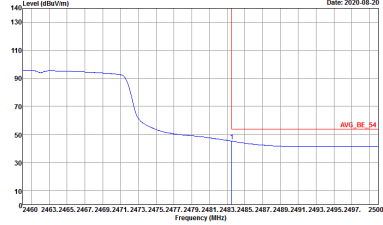
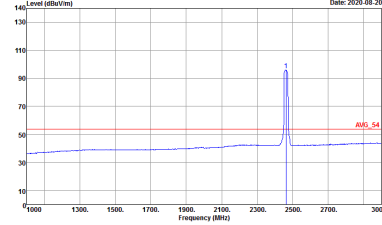

WIFI	2.4GHz 2400~2483.5MHz Band Edge @ 3m	
ANT	802.11ax HE20 Full CH11 2462MHz	
0+1	Horizontal	Fundamental
Peak	 <p>Site : 03CH12-1FV Condition : PEAK_BE_74 3m HORN_91200_1328 HORIZONTAL : RBW:1000.000kHz VBW:3000.000kHz SWT:Auto</p>	 <p>Site : 03CH12-1FV Condition : PEAK_T4 3m HORN_91200_1328 HORIZONTAL : RBW:1000.000kHz VBW:3000.000kHz SWT:Auto</p>
Avg.	 <p>Site : 03CH12-1FV Condition : AVG_BE_54 3m HORN_91200_1328 HORIZONTAL : RBW:1000.000kHz VBW:10.000kHz SWT:Auto</p>	 <p>Site : 03CH12-1FV Condition : AVG_54 3m HORN_91200_1328 HORIZONTAL : RBW:1000.000kHz VBW:10.000kHz SWT:Auto</p>

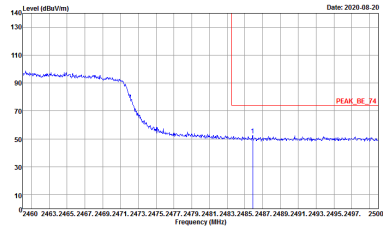
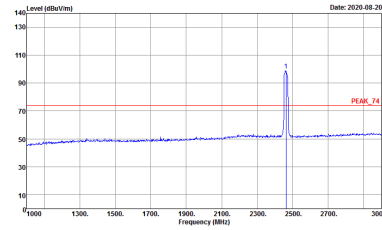
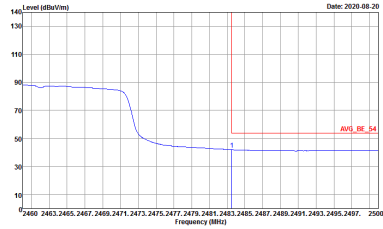
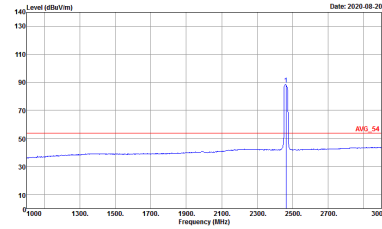

WIFI	2.4GHz 2400~2483.5MHz Band Edge @ 3m	
ANT	802.11ax HE20 Full CH11 2462MHz	
0+1	Vertical	Fundamental
Peak	 <p>Site : 03CH12-11Y Condition : PEAK_BE_74 3m HORN_9120D_1328 VERTICAL : RBW:1000.000kHz VBW:3000.000kHz SWT:Auto</p>	 <p>Site : 03CH12-11Y Condition : PEAK_74 3m HORN_9120D_1328 VERTICAL : RBW:1000.000kHz VBW:3000.000kHz SWT:Auto</p>
Avg.	 <p>Site : 03CH12-11Y Condition : AVG_BE_54 3m HORN_9120D_1328 VERTICAL : RBW:1000.000kHz VBW:10.000kHz SWT:Auto</p>	 <p>Site : 03CH12-11Y Condition : AVG_54 3m HORN_9120D_1328 VERTICAL : RBW:1000.000kHz VBW:10.000kHz SWT:Auto</p>



**2.4GHz 2400~2483.5MHz
WIFI 802.11b (Harmonic @ 3m)**

WIFI	2.4GHz 2400~2483.5MHz Harmonic @ 3m	
ANT	802.11b CH11 2462MHz	
0+1	Horizontal	Vertical
Peak Avg.	<p>Site : 03CH12-HY Condition : PEAK_74 3m HORN_91200_1328 HORIZONTAL Detector : Peak</p>	<p>Site : 03CH12-HY Condition : PEAK_74 3m HORN_91200_1328 VERTICAL Detector : Peak</p>



2.4GHz 2400~2483.5MHz
 WIFI 802.11n HT20 (Harmonic @ 3m)

WIFI	2.4GHz 2400~2483.5MHz Harmonic @ 3m	
ANT	802.11n HT20 CH11 2462MHz	
0+1	Horizontal	Vertical
Peak Avg.	<p>Site : 03CH12-4Y Condition : PEAK_74 3m HORN_91200_1328 HORIZONTAL Detector : Peak</p>	<p>Site : 03CH12-4Y Condition : PEAK_74 3m HORN_91200_1328 VERTICAL Detector : Peak</p>



2.4GHz 2400~2483.5MHz

WIFI 802.11 ax HE20 Full (Harmonic @ 3m)

WIFI	2.4GHz 2400~2483.5MHz Harmonic @ 3m	
ANT	802.11 ax HE20 Full CH11 2462MHz	
0+1	Horizontal	Vertical
Peak Avg.	<p>Site : 03CH12-4Y Condition : PEAK_74 3m HORN_91200_1328 HORIZONTAL Detector : Peak</p>	<p>Site : 03CH12-4Y Condition : PEAK_74 3m HORN_91200_1328 VERTICAL Detector : Peak</p>



**Emission above 18GHz
2.4GHz WIFI 802.11n HT20 (SHF)**

WIFI	2.4GHz 2400~2483.5MHz	
ANT	802.11n HT20 SHF	
0+1	Horizontal	Vertical
QP / Peak	<p>Site : 03CH12-44Y Condition : PEAK_74 1m SHF HORN 88H-A9170584 HORIZONTAL Detector : Peak</p>	<p>Site : 03CH12-44Y Condition : PEAK_74 1m SHF HORN 88H-A9170584 VERTICAL Detector : Peak</p>



Emission below 1GHz
2.4GHz WIFI 802.11n HT20 (LF)

WIFI	2.4GHz 2400~2483.5MHz	
ANT	802.11n HT20 LF	
0+1	Horizontal	Vertical
QP / Peak	<p>Site : 03CH12-HY Condition : QP 3m BIL06_6111D_37059 HORIZONTAL Detector : Peak</p>	<p>Site : 03CH12-HY Condition : QP 3m BIL06_6111D_37059 VERTICAL Detector : Peak</p>



Appendix D. Duty Cycle Plots

Antenna	Band	Duty Cycle(%)	T(us)	1/T(kHz)	VBW Setting	Duty Factor(dB)
0+1	802.11b for Ant 0	100.00	-	-	10Hz	0.00
0+1	802.11b for Ant 1	100.00	-	-	10Hz	0.00
0+1	2.4GHz 802.11n HT20 for Ant 0	100.00	-	-	10Hz	0.00
0+1	2.4GHz 802.11n HT20 for Ant 1	100.00	-	-	10Hz	0.00
0+1	802.11ax20 Full RU for Ant 0	100.00	-	-	10Hz	0.00
0+1	802.11ax20 Full RU for Ant 1	100.00	-	-	10Hz	0.00



MIMO <Ant. 0>

802.11b

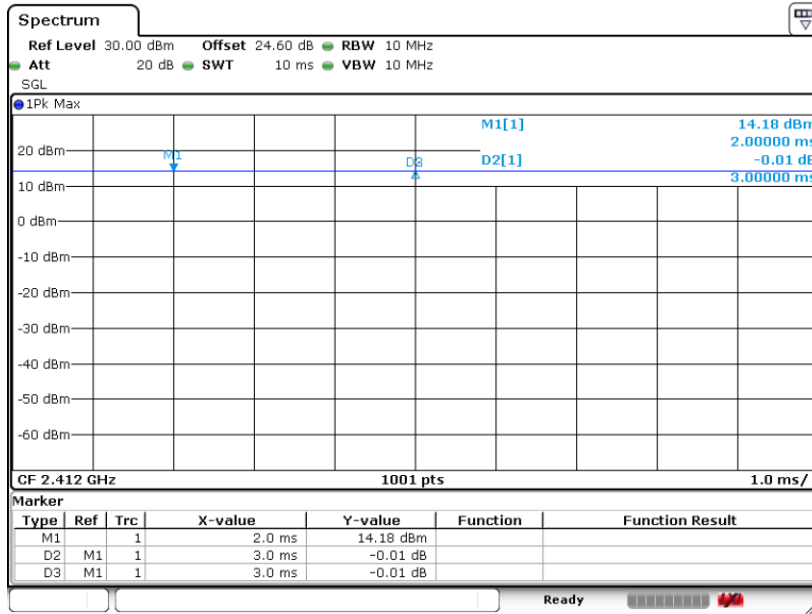

Date: 12.AUG.2020 10:49:56

802.11n HT20

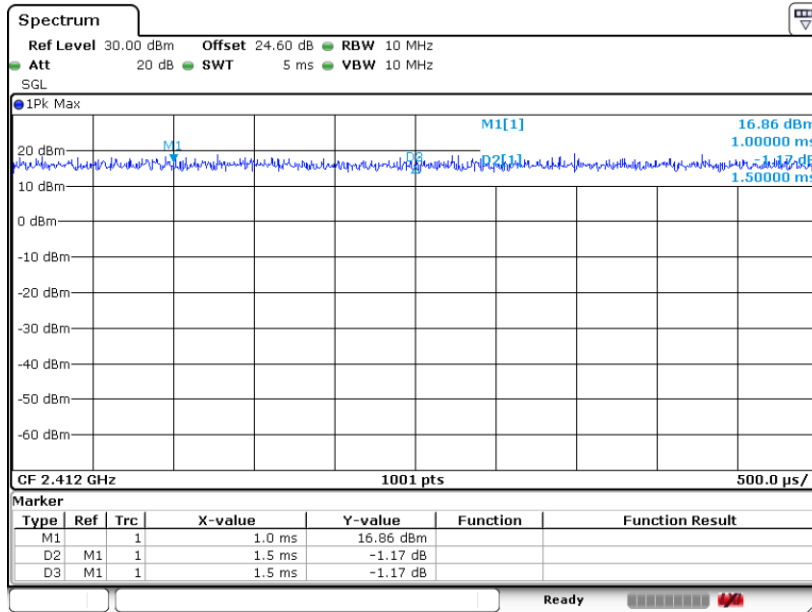

Date: 12.AUG.2020 11:49:33



802.11ax HE20 Full RU

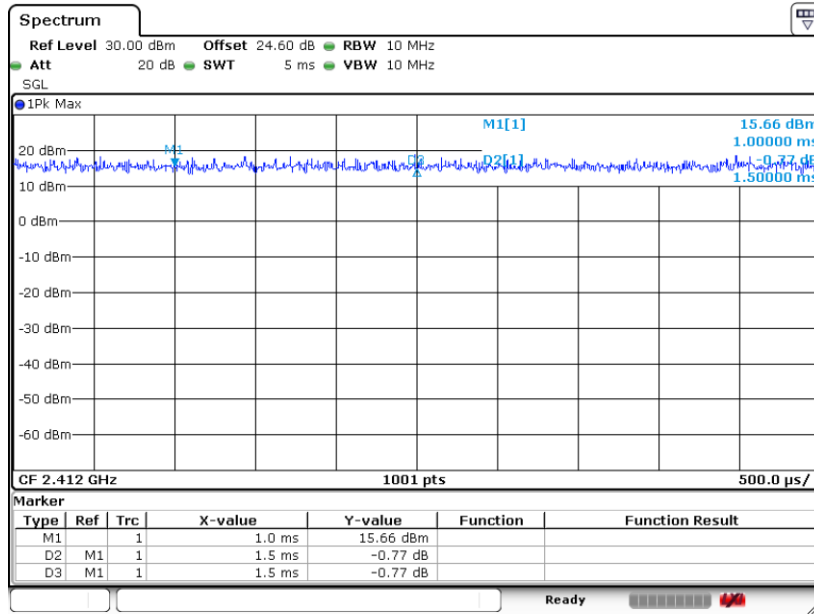

Date: 12.AUG.2020 14:05:45

MIMO <Ant. 1>

802.11b

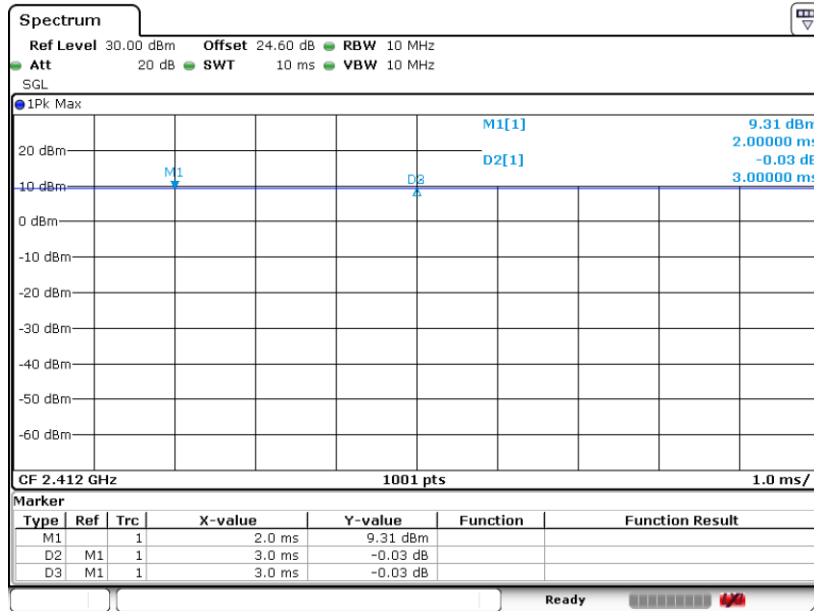

Date: 12.AUG.2020 10:52:28



802.11n HT20

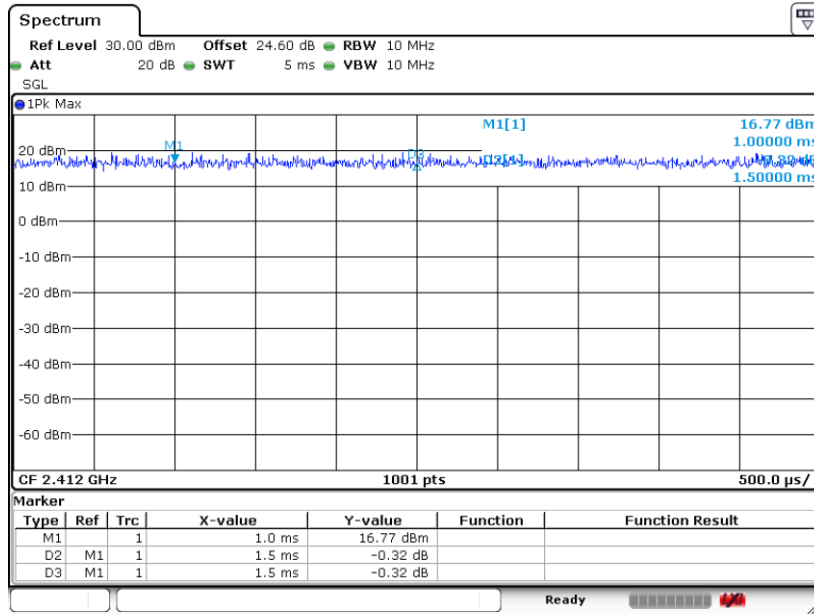

Date: 12.AUG.2020 11:51:11

802.11ax HE20 Full RU

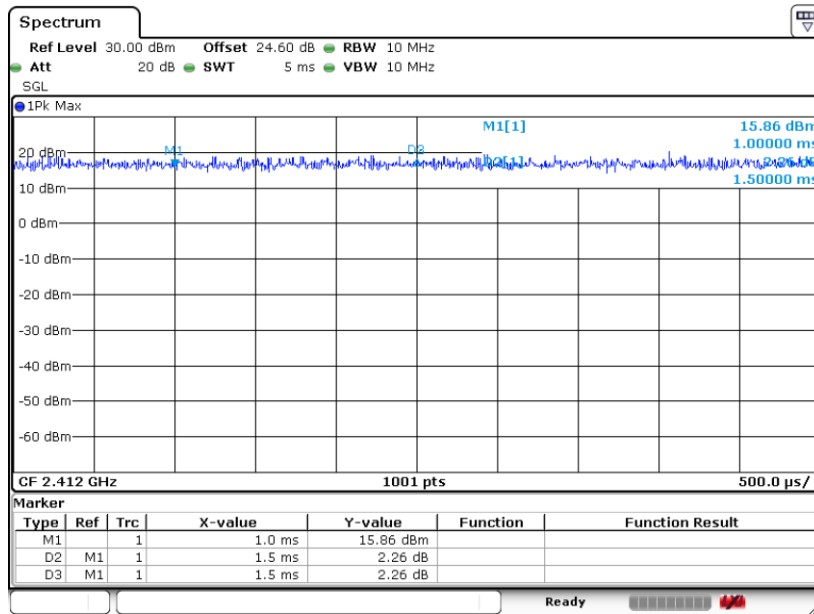

Date: 12.AUG.2020 14:09:07

— THE END —