

Preface

Thank you for buying "Xperia™ XZ" (simply called the "product" from here on). Before using the product, read "Basic Manual" (this manual) to ensure safe use and handling.

Packaged items

Before your start using the product, make sure that you have all the following packaged with the product.

- Xperia™ XZ (including warranty)
- Sony Mobile TV antenna cable 02 (02SOHSA)
- 取扱説明書 (Instruction Manual) (Japanese)
- Xperia™ XZのご利用にあつての注意事項 (Cautions on using Xperia™ XZ) (Japanese)
- 設定ガイド (Setting Guide) (Japanese)

The following items are not included in the package.

- microSD memory card
- AC adapter
- Earphones
- Desktop holder
- microUSB cable

◆Information

- Purchase a specified charger (sold separately).
- The battery is built into the product.
- Illustrations used in this manual are just images for explanations. They may be different from actual ones.

Basic Manual

About Operating Instructions

■ Basic Manual (this manual)

Handles only basic operations for main features. For detailed descriptions on various functions, refer to the "Basic Manual" (Japanese) app installed on the product or "取扱説明書 (詳細版) (Full Instruction Manual)" (Japanese) available on the au homepage. <http://www.au.kddi.com/support/mobile/guide/manual/>

■ "Basic Manual" (Japanese) app

The product allows you to use the "Basic Manual" (Japanese) app on the product to confirm detailed operational procedures. Certain functions can be directly activated from the app screens on which their operations are described.

From the Home screen, [設定]▶[お客さまサポート (Customer support)]▶[Basic Manual] (Japanese)

- When you activate for the first time, follow the onscreen instructions to download and install app.

■ For Those Requiring an English Instruction Manual

You can download the English version of the instruction manual from the au homepage (available in approximately one month after the product is released).

Download URL:

<http://www.au.kddi.com/english/support/manual/>

Regarding notations used in this document

- In this manual, screens and operations for the product with au Nano IC Card 04 attached are described.
- In this manual, keys (key icons) are represented by simplified illustrations such as ◀, ▶, □, ○, ☐, ☉.
- Operations of tapping menu items/icons/buttons on the screen etc. are indicated as [(name of the item etc.)].
- Screen illustrations shown in this manual may look different from the actual screens. In some cases, minor details or a part of a screen may be omitted.
- In this manual, "microSD™ memory card", "microSDHC™ memory card" and "microSDXC™ memory card" are abbreviated as "microSD memory card" or "microSD".
- All of the indicated amounts exclude tax unless otherwise specified.
- "The Company" as appears in the manual refers to the following companies:
Sold by: KDDI CORPORATION, OKINAWA CELLULAR TELEPHONE COMPANY
Manufactured by: Sony Mobile Communications Inc.

Getting Ready

Names and functions of parts

- ① Headset connection terminal
- ② Second microphone*1: Reduces noise to make easy to listen
- ③ Notification LED
- ④ NFC/Osaifu-Keitai position for holding over*2
- ⑤ Front camera
- ⑥ Earpiece/Speaker
- ⑦ Proximity/Light sensor: Switches touch panel on and off to prevent from erroneous operation during a call/Auto-control for display brightness
- ⑧ Display (Touch panel)
- ⑨ Speaker
- ⑩ Microphone
- ⑪ USB Type-C connection terminal
- ⑫ ◻ ☉ Power key/Screen lock key/Fingerprint sensor
- ⑬ Volume key/Zoom key
- ⑭ 📷 Camera key
- ⑮ Camera lens

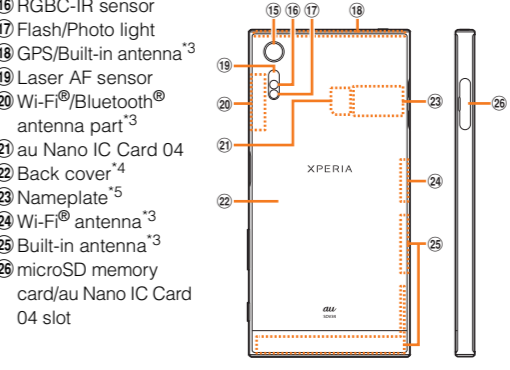

- *1 Do not jab with a sharp object such as a needle. Doing so may cause a fault.
- *2 ◻ ☉ mark sticker is attached at the time of purchase. Remove the sticker when you use a commercially available protective film.
- *3 The antenna is built in. Covering around the antenna by the hand may affect the quality of call/communication.
- *4 Back cover is not removable. Removing so forcibly might cause damage or a fault. Also, battery is built into the main unit and not removable by customers.
- *5 A sticker with CE mark, FCC ID, IMEI information, etc. printed is attached. Do not remove the sticker or nameplate.

- It may take longer to complete for charging with a PC or while using the camera function.

■ Charging with the AC Adapter

Charging with Common AC Adapter 05 (sold separately) is explained.

- 1 Insert the microUSB plug of Common AC Adapter 05 (sold separately), with the engraved side (▲) facing up, straight into the microUSB connection terminal of the product**
- 2 Insert the power plug of Common AC Adapter 05 (sold separately) into an outlet**
The start sound for charging sounds and Notification LED lights on the product.

- 3 When charging is complete, remove the microUSB plug of Common AC Adapter 05 (sold separately) from the product**
- 4 Remove the power plug of Common AC Adapter 05 (sold separately) from the outlet**

■ Charging with the DC Adapter

You can charge from cigarette lighter socket in a car by using Common DC Adapter 03 (sold separately). For details, refer to instruction manual of Common DC Adapter 03 (sold separately).

■ Charging with a PC

The followings describe charging procedure by connecting the product to chargeable USB port on a PC using microUSB cable 01 (sold separately).

- 1 Insert the microUSB plug of microUSB cable 01 (sold separately), with the engraved side (▲) facing up, straight into the microUSB connection terminal of the product**
- 2 Insert the USB plug of microUSB cable 01 (sold separately) into the USB port of a PC**
The start sound for charging sounds and Notification LED lights on the product.
When a screen for driver installation appears on the PC, wait for a while until the installation is complete. When a confirmation screen for software installation appears on the product, tap "SKIP" or "INSTALL". When "Use USB for" screen appears on the product, tap "CANCEL".
- 3 When charging is complete, remove the microUSB plug of microUSB cable 01 (sold separately) from the product and close the microUSB connection terminal cover firmly**
- 4 Remove the USB plug of microUSB cable 01 (sold separately) from the USB port of the PC**

■ Attaching the au Nano IC Card 04

- 1 Pull out the cover of microSD memory card/au Nano IC Card 04 slot while hooking the groove with your fingernail**
- 2 Pull out the tray straight from the product to remove**

5 Press the tray all the way and check there is no gap between the main unit and the cover

■ Removing au Nano IC Card 04

- 1 Put your fingernail into the groove to pull out the cover of microSD memory card/au Nano IC Card 04 slot**
- 2 Pull out the tray from the main unit to remove**
- 3 Remove au Nano IC Card 04 out of the tray, insert the tray into the main unit and then press it straight**
Pay attention to the direction of pushing the tray.
- 4 Press the tray all the way and check there is no gap between the main unit and the cover**

◆Information

- Note the following points, otherwise handling the au Nano IC Card 04 may cause malfunction or damage.
 - Do not touch the IC (metal) part of the au Nano IC Card 04.
 - Insert in the correct direction.
 - Do not use force to attach or remove.
- Do not lose the au Nano IC Card 04 after it has been removed.
- Do not insert au Nano IC Card 04 with conversion adapter attached. Doing so may cause a fault.

4 Insert the tray with the card into the main unit and then press it straight

Pay attention to the direction of inserting tray.

■ Attaching microSD memory card

- 1 Pull out the cover of microSD memory card/au Nano IC Card 04 slot while hooking the groove with your fingernail**
- 2 Pull out the tray from the main unit to remove**
- 3 Set microSD memory card into the tray with the terminal facing up**
Set a microSD memory card into the tray not to come off.

4 Insert the tray with the cards into the main unit and press it straight

Pay attention to the direction of inserting the tray.

could result in failure to remove the microSD memory card or damage.
• Do not touch the terminal of the microSD memory card.

■ Removing microSD memory card

- 1 Pull out the cover of microSD memory card/au Nano IC Card 04 slot cover while hooking the groove with your finger**
- 2 Pull out the tray from the main unit to remove**
- 3 Remove the microSD memory card out of the tray, insert the tray into the main unit and then press it straight**
Pay attention to the direction of inserting the tray.
- 4 Press the tray all the way and check there is no gap between the main unit and the cover**

Charging

When you purchase your product, the internal battery is not fully charged. Charge the battery before use.

◆Information

- When the charging starts with the product powered on, the start sound for charging sounds and Notification LED lights according to the battery level. To check the battery level, see the status bar in the top of the Home screen. Alternatively, from the Home screen, [設定]▶[Settings]▶[About phone]▶[Status] and see "Battery level".
- When you start charging with the product powered off, the power turns on even though operation is not available. Follow the instructions of each airline or medical facility for the use of mobile phones on their premises.

■ Force-quitting

- 1 Press and hold ◻ ○ and the upper part of the volume key at the same time for approximately eight seconds, and release your fingers after the product vibrates three times consecutively**

Setting Screen lock

When the screen lock is set, the backlight turns off to avoid the keys and touch panel from false operations. When the specified time elapses, the product's screen backlight turns off automatically and screen lock is activated.

- 1 While the screen is displayed, ◻ ○**

■ Unlocking screen

The lock screen appears when turning the power on or the screen backlight on by pressing ◻ ○.

- 1 On the lock screen, swipe (flick) the screen up or left**

◆Information

- On the lock screen, swipe (flick) * ↓ * or * 📷 * to activate "Voice Seach" app or "Camera" app, respectively.

Basic Operation

Key icons

The followings are the main functions of ◻ ▶, ◻ ▶, ◻ □ keys located at the bottom of the screen.



◻ ▶ Back	Return to the previous screen. Close a dialog box, menu, or the Notifications panel.
◻ ▶ Home	Display the Home screen. Long-touch to activate "Google" app.
◻ □ History	Display recently used apps on a list and activate or end them from the list.

Using the touch panel

The display of the product is a touch panel operated by touching it with your finger.

■ Tap/Double-tap

Tap: Gently touch a screen and then immediately release your finger. Double tap: Touch the same position twice.

■ Long-touch

Keep touching an item with your finger.

■ Slide

While your finger is gently touching the screen, trace it to the desired direction to move over.

■ Swipe (flick)

Operate the screen by quickly moving (flicking) your finger up/down or left/right.

■ Pinch

Touch the screen with two fingers and widen (pinch-out) or narrow (pinch-in) the fingers' distance.

■ Drag

Keep touching an item or icon, trace it to the desired direction to move.

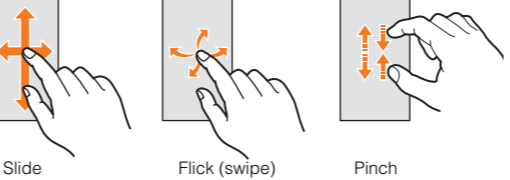

Setting app permission

- When accessing the functions or information for the first time, an access permission request appears. If it appears, confirm the content and tap "DENY" or "ALLOW".
- For some apps/functions, description for permission may appear. Or several confirmation screens or different permissions may appear. Confirm each content and follow the onscreen instructions.
- If you denied the permission, the app/function may not be activated or use of the function may be restricted.
- In this manual, descriptions for such access permissions may be omitted.

Home screen

Home screen consists of multiple screens. Tap ◻ ▶ to return to the Home screen any time.

- ① Google Search
- ② Widgets
- ③ Shortcuts (Apps)
- ④ Home screen position
Indicates which screen of the several Home screens you are in. Slide or flick left or right to move to the adjacent screen.
- ⑤ Wallpapers
- ⑥ Folders (Google, 基本機能 (Basic functions))
- ⑦ Apps key
If a confirmation screen related to data collection for the purpose of providing the app recommendations appears when it is tapped, tap "I AGREE" or "NOT NOW".



Adding to Home screen/Editing Home screen

You can change wallpaper or theme of the Home screen or add shortcuts of bookmarks etc., widgets on the Home screen.

- 1 Long-touch an area of the Home screen where no icons are displayed**

CE mark and FCC ID

- 1 Open the au Nano IC Card 04 slot cover, and insert a fingernail into the hook at the edge of the label tray, then pull it out straight.**

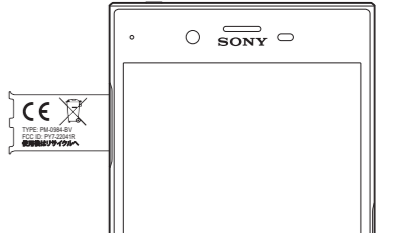

au Nano IC Card 04

Your phone number etc. is recorded in the au Nano IC Card 04. The product is compatible with au Nano IC Card 04.

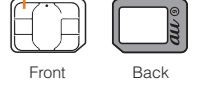

Attaching/removing the au Nano IC Card 04

Before attaching/removing the microSD memory card, make sure to turn off the product.

Turning on (Initial settings)

Turning the power on

- 1 ◻ ○ (over 1 sec)**
The product vibrates and after a while the lock screen appears. When "ようこそ (Welcome)" appears after the product is powered on, follow the onscreen instructions to set the initial settings.
- 2 Swipe (flick) the screen up or left**

■ Turning the power off

- 1 ◻ ○ (over 1 sec)**
- 2 [Power off]**

- ◆Information**
- Press ◻ ○ (over 1 sec) ▶ Long-touch "Power off" ▶ [OK] to restart the product in safe mode (a function that enables to start the product in a status equivalent to the status at the time of purchase).

■ Adding a folder

- 1 From the Home screen, long-touch an icon**
- 2 Drag the icon onto another icon**
- Deleting shortcuts/widgets/folders**
- 1 From the Home screen, long-touch an icon or a folder you want to delete**
- 2 Drag the icon or the folder to "Remove from Home screen" displayed at the top of the screen**
To delete a folder, then tap "DELETE". It also deletes shortcuts etc. in the folder.

- ◆Information**
- Long-touch a shortcut, widget, or folder icon to move.











Using the Apps screen

You can call up functions from the Apps screen. App icons installed to the product are also displayed.

- You may incur communication charges depending on the function.

■ Starting an app

- 1 From the Home screen, [設定]**
Slide or flick left or right to switch the Apps screen.
- 2 Tap an app to use**
Some apps are stored in a folder.

 Phone, Contacts	 Play Store
 E-mail, SMS	 Camera, Album
 Chrome	 Maps
 Settings	 Google, Voice Search
 Calendar	 Basic Manual

■ Downloading apps

You can download and install apps or games, etc. by using Google Play.

- To use Google Play, you need to set a Google account. For details, refer to "Setting Guide".

■ Deleting (uninstalling) apps

Before deleting installed apps, back up contents related to the app that you want to save including data saved in the app.

- Some apps may not be deleted.

Knowing the status of the product

■ Status bar

The status bar is located at the top of the product screen. On the left of the status bar, notification icons appear to inform missed calls, new mails, operations in progress, etc., and on the right, status icons appear to indicate the status of the product.

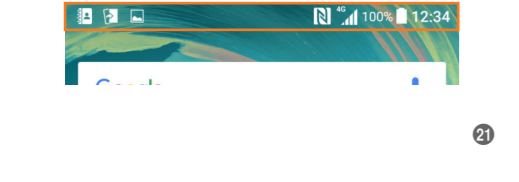

21

Symptom	What you should check
■ (Out of service area) appears	Is the product out of the service area or in an area where the signal is weak? <p>Is the built-in antenna covered with hand?</p> <p>Is au Nano IC Card 04 inserted?</p>
Cannot charge the battery (Notification LED does not light, the battery icon does not change into charging one)	Is the specified charging equipment (sold separately) attached properly?
Cannot operate key/touch panel	Is the power turned on? <p>Is "Screen lock" set?</p> <p>Turn off the power and then turn it on again.</p>
Cannot operate touch panel as intended	Are you operating with a fingernail or foreign object on the operating screen?
Charging is not complete	Is the temperature of the product raised or very low?
A message such as "charge the battery" appears	The battery is almost dead.

23

For inquiries, call: Customer Service Center

For general information, charges and operation information (toll free)
Business hours 9:00–20:00 (7 days a week)
From fixed-line phones:
From au mobile phones:

☎ 0077-7-111 **157** without area code

PRESSING ZERO WILL CONNECT YOU TO AN OPERATOR AFTER CALLING 157 ON YOUR au CELLPHONE.

For loss or theft (toll free)

Business hours : 24 hours live support
From fixed-line phones:
From au mobile phones:

☎ 0077-7-113 **113** without area code

In case above numbers are not available (toll free)

☎ 0120-977-033 (except Okinawa)

☎ 0120-977-699 (Okinawa)

Keitai Guarantee Service Center

For loss, theft, damage (toll free)

Business hours 9:00–20:00 (7 days a week)
From fixed-line phones/au mobile phones,



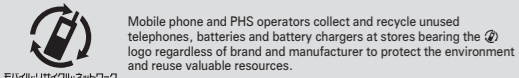



☎ 0120-925-919



SONY[®]















Sold by: KDDI CORPORATION, OKINAWA CELLULAR TELEPHONE COMPANY
Manufactured by: Sony Mobile Communications Inc.

■ Examples of notification icon

	New Gmail message
	New PC mail message
	New E-mail (@ezweb.ne.jp) message
	New SMS/Receiving notification service message, New Receiving notification
"Calling" icon" data-bbox="148 75 158 85"/>	Talking"/"Calling"
	Missed call
	USB device connected
	Wi-Fi® open network available

*1 Appears when switched to another screen such as the Home screen.

■ Main status icons

		Signal level (Level 4, Out of service area)
		4G (LTE/WiMAX 2+) data communication status*1 (Available, data transferring or downloading)
		Battery level (100%, Charging)
		Silent mode (Vibrate) is set
		Silent mode (Mute) is set
		Airplane mode is activated
		Wi-Fi® connected, Wi-Fi® communicating

*1 Two types of network, "LTE" and "WiMAX 2+" can be used. "4G" appears on the screen for both networks.

The company determines which network is less busy depending on the condition of the line to connect.

■ Notification panel

If any notification icons are displayed, slide down the status bar to open the Notification panel. You can check details of notification icons or start corresponding apps.

◆Information

- To delete a notification, flick the notification left or right. Some notifications may not be deleted depending on the content.
- Alternatively, you can check notifications by swiping (flicking) down on the lock screen. Or set to hide or keep showing notifications on the lock screen.

■ Notification LED

Notification LED informs charging prompt, battery level while charging, missed calls, new mails, etc. by turning on or flashing.

Status	Description
Red	The battery is charging when the remaining battery level is 14% or lower.
Orange	The battery is charging when the remaining battery level is 15% - 89%.
Green	The battery is charging when the remaining battery level is 90% or higher.
Flashing red	The remaining battery level is 14% or lower.
Flashing white	Indicates missed call, new Gmail message, new SMS message.*1

*1 Notification LED flashes while backlight is turned off.

Updating Software

You can update the product to the most recent software for optimal performance and to get the latest enhancements.

- You are charged for data communications when connecting to the Internet from the product by using packet communication.
- You are recommended to back up your data before updating software.
- For details, visit **http://www.sonymobile.co.jp/support/** or refer to the "Basic Manual" (Japanese) app or "取扱説明書（詳細版）(Full instruction manual)" (Japanese) available on au homepage.

■ Downloading and updating software

Update files can be downloaded from the Internet web site into the product directly.

- Note that when Wi-Fi® communication becomes unstable, packet communication takes the place automatically, which may apply communication fees.

1 From the Home screen, [☰]▶[Settings]▶[About phone]▶[Software update]

2 [☰]▶[Refresh]

After that, follow the onscreen instructions.

◆Information

- Flashing of Notification LED several times in red when pressing **[☰]** with the power off indicates that the remaining battery is not sufficient.
- When you start charging with the product powered off, Notification LED turns in red. When the status of battery appears on the display, however, Notification LED lights in color that indicates the battery level.

■ Checking own phone number

1 From the Home screen, [☰]▶[Settings]

2 [About phone]▶[Status]▶[SIM status]
The phone number of the product is shown under "My phone number".

◆Information

- Alternatively, from the Home screen, [☰]▶[Contacts]▶[Myself] to check your phone number.

■ Setting the silent mode (Vibrate)

1 Press the upper or lower part of the volume key

2 [☰]

The icon for the volume adjusting bar changes to  (white).

■ Setting the silent mode (Mute)

1 Press the upper or lower part of the volume key

2 [☰]▶Press the lower part of the volume key

The icon on the volume adjusting bar turns to  (gray).

◆Information

- By tapping **[☑]** on the volume adjusting bar, you can adjust volume of **[M]** (Media sound) or **[A]** (Alarm). However, setting of alarm volume in "Clock" app takes precedence.
- When the "silent mode" is set, sounds for shutter, shooting start/end sound when shooting videos, alarm, playback of video, or music, etc. are not muted.
- Raising the volume by pressing the upper part of the volume key in the silent mode, or adjusting volume of "Ring volume" of "Sound & notification" in the silent mode (Vibrate) cancels the silent mode.

■ Setting Airplane mode

When airplane mode is set, all wireless functions (phone, packet communication, Wi-Fi® function, Bluetooth® function, NFC Reader/Writer, P2P function) are turned off.

1 From the Home screen, [☰] ▶[Settings]

2 [☰] of "Airplane mode"

Entering characters

Use software keyboard to enter characters.

To display the software keyboard, tap a character input box on the character entry screen for adding contacts, creating a message, etc.

■ Switching software keyboards

With "International keyboard", you can use QWERTY keyboard to enter characters, Numeric keypad to enter numbers and symbols, and Symbol keypad for more symbols.

1 Tap a character input box

QWERTY keyboard appears.

24

After-sales service

■ When asking for repair

For repair, contact Keitai Guarantee Service Center.

During the warranty period	Repairs will be done based on the terms of services of the free-of-charge repair warranty described on the warranty card.
Outside the warranty period	We shall repair the product for a charge as requested by the customer if repair renders it usable.

◆Information

- Before handing in the product for repair, make a backup of the contents of memory since they may disappear during repair. Note that the Company shall not be liable for any damages and loss of income should the contents of memory be altered or lost.
- Recycled parts that meet the Company's quality standards are sometimes used for repair.
- Collected au mobile phones by Replacement mobile phone delivery service which you used before are recycled to mobile phones for replacement after repairs. Also replaced parts by au after-sales service are collected and recycled by KDDI. They are not returned to customers.
- The product which is processed, remodeled, analyzed (including by modifying or analyzing the software (including by rooting etc.), reverse engineering, decompiling), or repaired by an unauthorized repair office is not covered by the warranty and repair may be refused.

31

SIM unlock

The product supports SIM unlock. By unlocking SIM lock, you can use non-au SIM cards.

- The SIM unlock service is provided at the au homepage and au shops.
- Some services, functions, etc. may be unavailable when using non-au SIM card. The Company is not liable for any operations.
- For settings after SIM unlock, operate from the Home screen, [☰]▶[Settings]▶[About phone]▶[Status]▶[SIM status]▶[SIM card status].
- For details, refer to the au homepage.
https://cs.kddi.com/support/simcard/

Main specifications

Display	Approx. 5.0 inches TRILUMINOS® Display for mobile Approx. 16.77 million colors
Weight	Approx. 165 g
Dimension (W x H x T)	Approx. 71 mm x 144 mm x 8.6 mm
Internal memory	ROM: Approx. 32GB RAM: Approx. 3GB
Image pickup device (type)	Camera: Backside-illumination layered CMOS Front camera: Backside-illumination layered CMOS

37

2 Tap [☰] to display Numeric keypad

For Symbol keypad, tap **[☑]** on the Numeric keypad.

◆Information

- Tap **[☑]** at the bottom of the screen to hide the software keyboard.
- Tap **[☒]** to delete the character before the cursor.
- Switch between lower-case **[a-z]**, upper-case **[A-Z]** and caps **[!@#]** on QWERTY keyboard.
- When using QWERTY keyboard, touch and hold a character to select a character variant.

Support

Introduction of related accessories

For details, refer to the instruction manual for each device.

- Sony Mobile TV antenna cable 02 (02SOHSA)**
- Sony Mobile Desktop Holder 01 (01SOPUA) (sold separately)**
- Common AC Adapter 05 (0501PWA) (sold separately)**
- Common DC Adapter 03 (0301PEA) (sold separately)**
- microUSB cable 01 (0301HVA) (sold separately)**
- microUSB cable 01 Navy (0301HBA) (sold separately)**
- microUSB cable 01 Green (0301HGA) (sold separately)**
- microUSB cable 01 Pink (0301HPA) (sold separately)**
- microUSB cable 01 Blue (0301HLA) (sold separately)**
- au Carrying Case G Black (0106FCA) (sold separately)**

◆Information

For the latest information on accessories, visit the au homepage (**http://www.au.kddi.com/**) or contact the Customer Service Center.

- Accessories described above can be purchased from the au Online Shop. Some accessories may not be purchased due to the availability.
http://aunlineshop.kddi.com/

Troubleshooting

Before you assume that the product is malfunctioning, check the following:

Symptom	What you should check
Power is not turned on even though [☰] is pressed	Is the internal battery charged? <p>Is [☰] pressed for over 1 second?</p>
The power goes off	Is the internal battery charged?
The power turns off while activation screen is displayed	Is the internal battery charged?
The screen freezes and the power cannot be turned off	Shut down forcibly by pressing and holding [☰] and the upper part of the volume key at the same time for approximately eight seconds, and releasing your finger after it vibrates three times consecutively.



27

Online Reception Desk (24 hours a day over the Internet)
* Reception only from PC or smartphone
https://cs.kddi.com/support/n_login.html



- The App for the Internet acceptance, if "damage", "wet", "theft" and "loss" are eligible. In the case of spontaneous failure (not the cause damage, such as water wet, but does not power on, the screen does not function or other), it will be accepted by phone for interview is required.
- To apply for the Internet, you need the e-mail address.

■ au after-sales service information Replacement mobile phone delivery service

Spontaneous failure 1st year	Free of charge
Spontaneous failure 2nd year or later	See table of "Replacement mobile phone delivery service (Member) Customer charge" (Member) Customer charge"
Partially damage, water soak, irreparable damage, theft or loss	

Spontaneous failure 1st year	No recompense
Spontaneous failure 2nd year or later	
Partially damage, water soak, irreparable damage, theft or loss	

34

Camera pixels	Camera: Effective pixels Approx. 23 million pixels Front camera: Effective pixels Approx. 13.2 million pixels
Continuous call time	In Japan Approx. 1,330 min. Overseas (GSM) Approx. 630 min.
Continuous stand-by time	In Japan Approx. 490 hours Overseas (GSM) Approx. 520 hours
Charging time	Using Common AC Adapter 05 (sold separately): Approx. 150 min.
Continuous Full Seg watching time	Approx. 7 hours 10 min.
Continuous 1Seg viewing time	Approx. 8 hours 40 min.
Continuous tethering time	Approx. 440 min.
Wi-Fi® tethering maximum connection number	10

*1 Varies by obstruction between communication devices or radio wave reception status.

*2 It is a specification according to purpose of use of Bluetooth® device and is defined by Bluetooth® standard.

*3 Some contacts data may not be displayed correctly on the other party's device.

*4 Only supported to a part of car navigation systems. For use, refer to the au homepage.

◆Information

- The continuous call time, continuous stand-by time, continuous Full Seg watching time, continuous 1Seg viewing time and continuous tethering time may drop to less than half depending on the battery charging status, usage environment such as temperature, reception condition at the location where the product is used, and the function settings.

35

36

38

39

40