



# FCC RF Test Report

**APPLICANT** : Sony Mobile Communications Inc.  
**EQUIPMENT** : GSM/WCDMA/LTE Phone+Bluetooth,  
DTS/UNII a/b/g/n and NFC  
**BRAND NAME** : Sony  
**FCC ID** : PY7-22032B  
**STANDARD** : FCC 47 CFR Part 2, 22(H), 24(E), 27(L)  
**CLASSIFICATION** : PCS Licensed Transmitter Held to Ear (PCE)

The product was received on Aug. 21, 2017 and testing was completed on Sep. 07, 2017. We, SPORTON INTERNATIONAL INC., would like to declare that the tested sample has been evaluated in accordance with the test procedures given in ANSI / TIA-603-E-2016 and has been in compliance with the applicable technical standards.

The test results in this report apply exclusively to the tested model / sample. Without written approval of SPORTON INTERNATIONAL INC., the test report shall not be reproduced except in full.

Reviewed by: Joseph Lin / Supervisor

Approved by: Jones Tsai / Manager



## **SPORTON INTERNATIONAL INC.**

**No. 52, Hwa Ya 1<sup>st</sup> Rd., Hwa Ya Technology Park, Kwei-Shan District, Tao Yuan City, Taiwan, R.O.C.**

SPORTON INTERNATIONAL INC.

TEL : 886-3-327-3456

FAX : 886-3-328-4978

FCC ID : PY7-22032B

Page Number : 1 of 22

Report Issued Date : Nov. 13, 2017

Report Version : Rev. 01

Report Template No.: BU5-FG22/24/27 Version 2.0



# TABLE OF CONTENTS

**REVISION HISTORY..... 3**

**SUMMARY OF TEST RESULT ..... 4**

**1 GENERAL DESCRIPTION ..... 5**

    1.1 Applicant..... 5

    1.2 Manufacturer ..... 5

    1.3 Product Feature of Equipment Under Test ..... 5

    1.4 Modification of EUT ..... 5

    1.5 Maximum ERP/EIRP Power, Frequency Tolerance, and Emission Designator ..... 6

    1.6 Testing Location ..... 7

    1.7 Applicable Standards ..... 7

**2 TEST CONFIGURATION OF EQUIPMENT UNDER TEST ..... 8**

    2.1 Test Mode..... 8

    2.2 Connection Diagram of Test System ..... 9

    2.3 Support Unit used in test configuration ..... 9

    2.4 Measurement Results Explanation Example ..... 9

    2.5 Frequency List of Low/Middle/High Channels ..... 10

**3 CONDUCTED TEST RESULT ..... 11**

    3.1 Measuring Instruments..... 11

    3.2 Test Setup ..... 11

    3.3 Test Result of Conducted Test..... 11

    3.4 Conducted Output Power and ERP/EIRP ..... 12

    3.5 Peak-to-Average Ratio ..... 13

    3.6 99% Occupied Bandwidth and 26dB Bandwidth Measurement..... 14

    3.7 Conducted Band Edge ..... 15

    3.8 Conducted Spurious Emission ..... 16

    3.9 Frequency Stability..... 17

**4 RADIATED TEST ITEMS ..... 18**

    4.1 Measuring Instruments..... 18

    4.2 Test Setup ..... 18

    4.3 Test Result of Radiated Test..... 18

    4.4 Field Strength of Spurious Radiation Measurement ..... 19

**5 LIST OF MEASURING EQUIPMENT ..... 20**

**6 UNCERTAINTY OF EVALUATION ..... 22**

**APPENDIX A. TEST RESULTS OF CONDUCTED TEST**

**APPENDIX B. TEST RESULTS OF RADIATED TEST**



### REVISION HISTORY

REPORT NO.	VERSION	DESCRIPTION	ISSUED DATE
FG782204A	Rev. 01	Initial issue of report	Nov. 13, 2017



## SUMMARY OF TEST RESULT

Report Section	FCC Rule	Description	Limit	Result	Remark
3.4	§2.1046	Conducted Output Power	Reporting Only	PASS	-
	§22.913(a)(2)	Effective Radiated Power	< 7 Watts	PASS	-
	§24.232(c)	Equivalent Isotropic Radiated Power	< 2 Watts	PASS	-
	§27.50(d)(4)	Equivalent Isotropic Radiated Power	< 1 Watts	PASS	-
3.5	§24.232(d)	Peak-to-Average Ratio	< 13 dB	PASS	-
3.6	§2.1049 §22.917(b) §24.238(b) §27.53(g)	Occupied Bandwidth	Reporting Only	PASS	-
3.7	§2.1051 §22.917(a) §24.238(a) §27.53(h)	Band Edge Measurement	< 43+10log10(P[Watts])	PASS	-
3.8	§2.1051 §22.917(a) §24.238(a) §27.53(h)	Conducted Emission	< 43+10log10(P[Watts])	PASS	-
3.9	§2.1055 §22.355	Frequency Stability for Temperature & Voltage	< 2.5 ppm for Part 22	PASS	-
	§2.1055 §24.235 §27.54		Within Authorized Band		
4.4	§2.1053 §22.917(a) §24.238(a) §27.53(h)	Field Strength of Spurious Radiation	< 43+10log10(P[Watts])	PASS	Under limit 30.36 dB at 2512.000 MHz



# 1 General Description

## 1.1 Applicant

**Sony Mobile Communications Inc.**

4-12-3 Higashi-Shinagawa, Shinagawa-ku, Tokyo, 140-0002, Japan

## 1.2 Manufacturer

**Sony Mobile Communications Inc.**

4-12-3 Higashi-Shinagawa, Shinagawa-ku, Tokyo, 140-0002, Japan

## 1.3 Product Feature of Equipment Under Test

GSM/WCDMA/LTE, Bluetooth, DTS/UNII a/b/g/n, FM Receiver, NFC, and GPS.

Standards-related Product Specification	
Antenna Type	PIFA Antenna

EUT Information List			
HW Version	SW Version	S/N	Performed Test Item
A	1.8	WUJ01Q2CR3	Conducted Measurement ERP/EIRP Test Radiated Spurious Emission

Accessory List	
AC Adapter	Model Name: EP800
	S/N: 3013W45408581
Earphone	Model Name: MH410c
	S/N: N/A
USB Cable	Model Name: UCB20
	S/N: 3015W42100446

**Note:**

1. Above EUT list and accessory list used are electrically identical per declared by manufacturer.
2. Above the accessories list are used to exercise the EUT during test.
3. For other wireless features of this EUT, test report will be issued separately.

## 1.4 Modification of EUT

No modifications are made to the EUT during all test items.



### 1.5 Maximum ERP/EIRP Power, Frequency Tolerance, and Emission Designator

FCC Rule	Frequency Range (MHz)	System	Type of Modulation	Maximum ERP/EIRP (W)	Frequency Tolerance (ppm)	Emission Designator
Part 22	824.2 ~848.8	GSM850 GPRS class 8	GMSK	0.8318	0.0060 ppm	248KGXW
Part 22	824.2 ~848.8	GSM850 EDGE class 8	8PSK	0.2193	0.0215 ppm	254KG7W
Part 22	826.4 ~846.6	WCDMA Band V RMC 12.2Kbps	BPSK	0.1069	0.0167 ppm	4M22F9W
Part 24	1850.2 ~1909.8	GSM1900 GPRS class 8	GMSK	1.0715	0.0144 ppm	248KGXW
Part 24	1850.2 ~1909.8	GSM1900 EDGE class 8	8PSK	0.4457	0.0048 ppm	255KG7W
Part 24	1852.4 ~ 1907.6	WCDMA Band II RMC 12.2Kbps	BPSK	0.1585	0.0085 ppm	4M22F9W
Part 27	1712.4 ~ 1752.6	WCDMA Band IV RMC 12.2Kbps	BPSK	0.3365	0.0017 ppm	4M22F9W



### 1.6 Testing Location

Sporton Lab is accredited to ISO 17025 by Taiwan Accreditation Foundation (TAF code : 1190) and the FCC designation No. TW1190 under the FCC 2.948(e) by Mutual Recognition Agreement (MRA) in FCC Test.

<b>Test Site</b>	SPORTON INTERNATIONAL INC.	
<b>Test Site Location</b>	No. 52, Hwa Ya 1 <sup>st</sup> Rd., Hwa Ya Technology Park, Kwei-Shan District, Tao Yuan City, Taiwan, R.O.C. TEL: +886-3-327-3456 FAX: +886-3-328-4978	
<b>Test Site No.</b>	<b>Sporton Site No.</b>	
	TH03-HY	03CH07-HY

### 1.7 Applicable Standards

According to the specifications of the manufacturer, the EUT must comply with the requirements of the following standards:

- ♦ 47 CFR Part 2, 22(H), 24(E), 27(L)
- ♦ ANSI / TIA-603-E-2016
- ♦ FCC KDB 971168 D01 Power Meas. License Digital Systems v03
- ♦ FCC KDB 412172 D01 Determining ERP and EIRP v01r01

**Remark:**

1. All test items were verified and recorded according to the standards and without any deviation during the test.
2. This EUT has also been tested and complied with the requirements of FCC Part 15, Subpart B, recorded in a separate test report.



## 2 Test Configuration of Equipment Under Test

### 2.1 Test Mode

Antenna port conducted and radiated test items were performed according to KDB 971168 D01 Power Meas. License Digital Systems v03 with maximum output power.

Radiated measurements were performed with rotating EUT in different three orthogonal test planes to find the maximum emission.

Radiated emissions were investigated as following frequency range:

1. 30 MHz to 9000 MHz for GSM850 and WCDMA Band V.
2. 30 MHz to 18000 MHz for WCDMA Band IV.
3. 30 MHz to 19100 MHz for GSM1900 and WCDMA Band II.

All modes and data rates and positions were investigated.

Test modes are chosen to be reported as the worst case configuration below:

Test Modes		
Band	Radiated TCs	Conducted TCs
GSM 850	<ul style="list-style-type: none"> <li>■ GPRS class 8 Link</li> <li>■ EDGE class 8 Link</li> </ul>	<ul style="list-style-type: none"> <li>■ GPRS class 8 Link</li> <li>■ EDGE class 8 Link</li> </ul>
GSM 1900	<ul style="list-style-type: none"> <li>■ GPRS class 8 Link</li> <li>■ EDGE class 8 Link</li> </ul>	<ul style="list-style-type: none"> <li>■ GPRS class 8 Link</li> <li>■ EDGE class 8 Link</li> </ul>
WCDMA Band V	<ul style="list-style-type: none"> <li>■ RMC 12.2Kbps Link</li> </ul>	<ul style="list-style-type: none"> <li>■ RMC 12.2Kbps Link</li> </ul>
WCDMA Band II	<ul style="list-style-type: none"> <li>■ RMC 12.2Kbps Link</li> </ul>	<ul style="list-style-type: none"> <li>■ RMC 12.2Kbps Link</li> </ul>
WCDMA Band IV	<ul style="list-style-type: none"> <li>■ RMC 12.2Kbps Link</li> </ul>	<ul style="list-style-type: none"> <li>■ RMC 12.2Kbps Link</li> </ul>



## 2.2 Connection Diagram of Test System

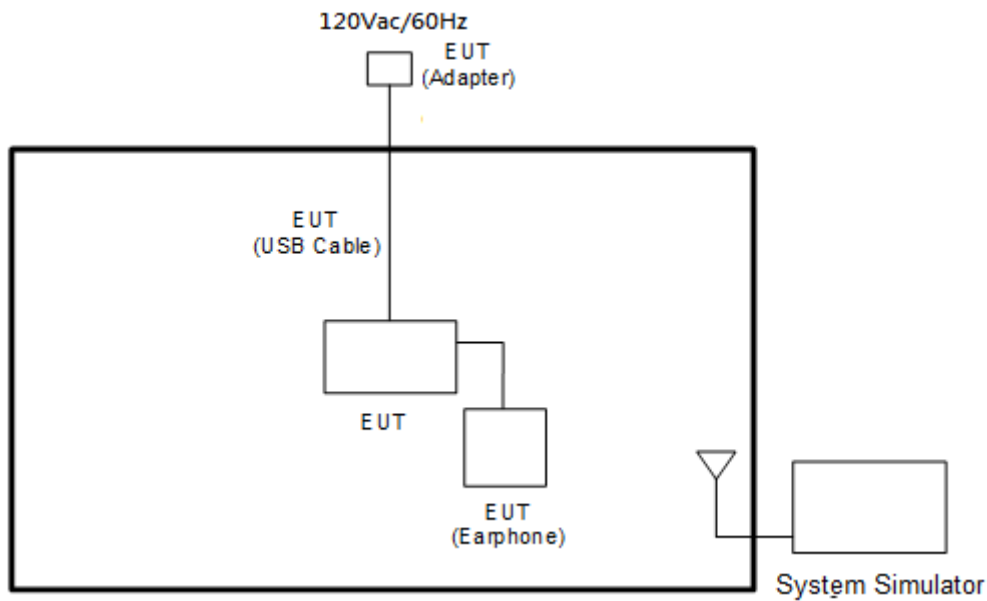

## 2.3 Support Unit used in test configuration

Item	Equipment	Trade Name	Model No.	FCC ID	Data Cable	Power Cord
1.	System Simulator	R&S	CMU 200	N/A	N/A	Unshielded, 1.8 m

## 2.4 Measurement Results Explanation Example

### For all conducted test items:

The offset level is set in the spectrum analyzer to compensate the RF cable loss and attenuator factor between RF conducted output port and spectrum analyzer. With the offset compensation, the spectrum analyzer reading level will be exactly the RF output level.

The spectrum analyzer offset is derived from RF cable loss and attenuator factor.

*Offset = RF cable loss + attenuator factor.*

The following shows an offset computation example with RF cable loss 4.2 dB and a 10dB attenuator.

Example :

*Offset(dB) = RF cable loss(dB) + attenuator factor(dB).*

$$= 4.2 + 10 = 14.2 \text{ (dB)}$$



## 2.5 Frequency List of Low/Middle/High Channels

Frequency List				
Band	Channel/Frequency(MHz)	Lowest	Middle	Highest
GSM850	Channel	128	189	251
	Frequency	824.2	836.4	848.8
WCDMA Band V	Channel	4132	4182	4233
	Frequency	826.4	836.4	846.6
GSM1900	Channel	512	661	810
	Frequency	1850.2	1880.0	1909.8
WCDMA Band II	Channel	9262	9400	9538
	Frequency	1852.4	1880.0	1907.6
WCDMA Band IV	Channel	1312	1413	1513
	Frequency	1712.4	1732.6	1752.6

### 3 Conducted Test Result

#### 3.1 Measuring Instruments

See list of measuring instruments of this test report.

#### 3.2 Test Setup

##### 3.2.1 Conducted Output Power



##### 3.2.2 Peak-to-Average Ratio, Occupied Bandwidth, Conducted Band-Edge and Conducted Spurious Emission

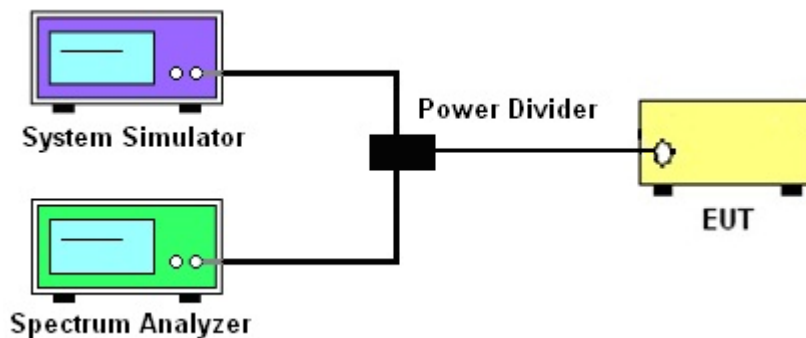

##### 3.2.3 Frequency Stability

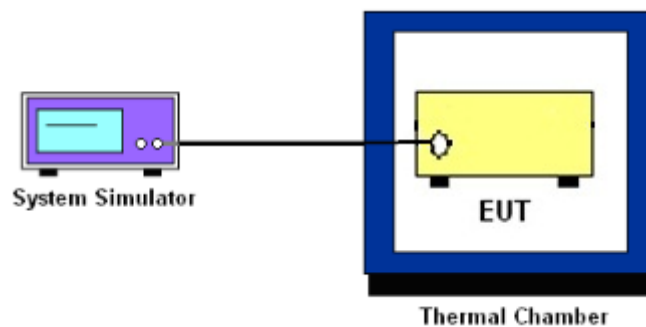

### 3.3 Test Result of Conducted Test

Please refer to Appendix A.



### 3.4 Conducted Output Power and ERP/EIRP

#### 3.4.1 Description of the Conducted Output Power and ERP/EIRP

A system simulator was used to establish communication with the EUT. Its parameters were set to enforce EUT transmitting at the maximum power. The measured power in the radio frequency on the transmitter output terminals shall be reported.

The ERP of mobile transmitters must not exceed 7 Watts for GSM850 and WCDMA Band V.

The EIRP of mobile transmitters must not exceed 2 Watts for GSM1900 and WCDMA Band II.

The EIRP of mobile transmitters must not exceed 1 Watts for WCDMA Band IV.

According to KDB 412172 D01 Power Approach,

$EIRP = P_T + G_T - L_C$ ,  $ERP = EIRP - 2.15$ , where

$P_T$  = transmitter output power in dBm

$G_T$  = gain of the transmitting antenna in dBi

$L_C$  = signal attenuation in the connecting cable between the transmitter and antenna in dB

#### 3.4.2 Test Procedures

1. The transmitter output port was connected to the system simulator.
2. Set EUT at maximum power through system simulator.
3. Select lowest, middle, and highest channels for each band and different modulation.
4. Measure the maximum burst average power for GSM and maximum average power for other modulation signal.



## **3.5 Peak-to-Average Ratio**

### **3.5.1 Description of the PAR Measurement**

The peak-to-average ratio (PAR) of the transmission may not exceed 13 dB.

### **3.5.2 Test Procedures**

1. The testing follows FCC KDB 971168 D01 v03 Section 5.7.1.
2. The EUT was connected to spectrum analyzer and system simulator via a power divider.
3. Set EUT to transmit at maximum output power.
4. When the duty cycle is less than 98%, then signal gating will be implemented on the spectrum analyzer by triggering from the system simulator.
5. Set the CCDF (Complementary Cumulative Distribution Function) option of the spectrum analyzer.  
Record the maximum PAPR level associated with a probability of 0.1%.



### **3.6 99% Occupied Bandwidth and 26dB Bandwidth Measurement**

#### **3.6.1 Description of 99% Occupied Bandwidth and 26dB Bandwidth Measurement**

The occupied bandwidth is the width of a frequency band such that, below the lower and above the upper frequency limits, the mean powers emitted are each equal to a specified percentage 0.5% of the total mean transmitted power.

The 26 dB emission bandwidth is defined as the frequency range between two points, one above and one below the carrier frequency, at which the spectral density of the emission is attenuated 26 dB below the maximum in-band spectral density of the modulated signal. Spectral density (power per unit bandwidth) is to be measured with a detector of resolution bandwidth equal to approximately 1.0% of the emission bandwidth.

#### **3.6.2 Test Procedures**

1. The testing follows FCC KDB 971168 v03 Section 4.2.
2. The EUT was connected to spectrum analyzer and system simulator via a power divider.
3. The spectrum analyzer center frequency is set to the nominal EUT channel center frequency. The span range for the spectrum analyzer shall be between two and five times the anticipated OBW.
4. The nominal resolution bandwidth (RBW) shall be in the range of 1 to 5 % of the anticipated OBW, and the VBW shall be at least 3 times the RBW.
5. Set the detection mode to peak, and the trace mode to max hold.
6. Determine the reference value: Set the EUT to transmit a modulated signal. Allow the trace to stabilize. Set the spectrum analyzer marker to the highest level of the displayed trace.  
(this is the reference value)
7. Determine the “-26 dB down amplitude” as equal to (Reference Value – X).
8. Place two markers, one at the lowest and the other at the highest frequency of the envelope of the spectral display such that each marker is at or slightly below the “-X dB down amplitude” determined in step 6. If a marker is below this “-X dB down amplitude” value it shall be placed as close as possible to this value. The OBW is the positive frequency difference between the two markers.
9. Use the 99 % power bandwidth function of the spectrum analyzer and report the measured bandwidth.



### **3.7 Conducted Band Edge**

#### **3.7.1 Description of Conducted Band Edge Measurement**

The power of any emission outside of the authorized operating frequency ranges must be lower than the transmitter power (P) by a factor of at least  $43 + 10 \log (P)$  dB.

#### **3.7.2 Test Procedures**

1. The testing follows FCC KDB 971168 D01 v03 Section 6.0.
2. The EUT was connected to the spectrum analyzer and system simulator via a power divider.
3. The RF output of EUT was connected to the spectrum analyzer by an RF cable and attenuator. The path loss was compensated to the results for each measurement.
4. The band edges of low and high channels for the highest RF powers were measured.
5. The RF fundamental frequency should be excluded against the limit line in the operating frequency band.
6. The limit line is derived from  $43 + 10\log(P)$  dB below the transmitter power P(Watts)



### 3.8 Conducted Spurious Emission

#### 3.8.1 Description of Conducted Spurious Emission Measurement

The power of any emission outside of the authorized operating frequency ranges must be lower than the transmitter power (P) by a factor of at least  $43 + 10 \log (P)$  dB.

It is measured by means of a calibrated spectrum analyzer and scanned from 30 MHz up to a frequency including its 10<sup>th</sup> harmonic.

#### 3.8.2 Test Procedures

1. The testing follows FCC KDB 971168 D01 v03 Section 6.0.
2. The EUT was connected to the spectrum analyzer and system simulator via a power divider.
3. The RF output of EUT was connected to the spectrum analyzer by an RF cable and attenuator. The path loss was compensated to the results for each measurement.
4. The middle channel for the highest RF power within the transmitting frequency was measured.
5. The conducted spurious emission for the whole frequency range was taken.
6. The RF fundamental frequency should be excluded against the limit line in the operating frequency band.
7. The limit line is derived from  $43 + 10\log(P)$  dB below the transmitter power P(Watts)





### 3.9 Frequency Stability

#### 3.9.1 Description of Frequency Stability Measurement

The frequency stability shall be measured by variation of ambient temperature and variation of primary supply voltage to ensure that the fundamental emission stays within the authorized frequency block. The frequency stability of the transmitter shall be maintained within  $\pm 0.00025\%$  ( $\pm 2.5\text{ppm}$ ) of the center frequency.

#### 3.9.2 Test Procedures for Temperature Variation

1. The testing follows FCC KDB 971168 D01 v03 Section 9.0.
2. The EUT was set up in the thermal chamber and connected with the system simulator.
3. With power OFF, the temperature was decreased to  $-30^{\circ}\text{C}$  and the EUT was stabilized before testing. Power was applied and the maximum change in frequency was recorded within one minute.
4. With power OFF, the temperature was raised in  $10^{\circ}\text{C}$  steps up to  $50^{\circ}\text{C}$ . The EUT was stabilized at each step for at least half an hour. Power was applied and the maximum frequency change was recorded within one minute.

#### 3.9.3 Test Procedures for Voltage Variation

1. The testing follows FCC KDB 971168 D01 v03 Section 9.0.
2. The EUT was placed in a temperature chamber at  $20\pm 5^{\circ}\text{C}$  and connected with the system simulator.
3. The power supply voltage to the EUT was varied from 85% to 115% of the nominal value measured at the input to the EUT.
4. The variation in frequency was measured for the worst case.

## 4 Radiated Test Items

### 4.1 Measuring Instruments

See list of measuring instruments of this test report.

### 4.2 Test Setup

#### 4.2.1 For radiated test from 30MHz to 1GHz

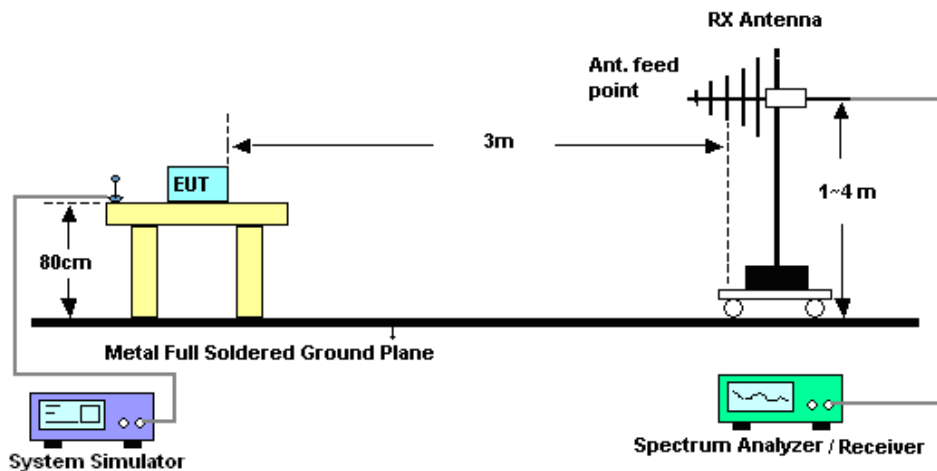

#### 4.2.2 For radiated test above 1GHz

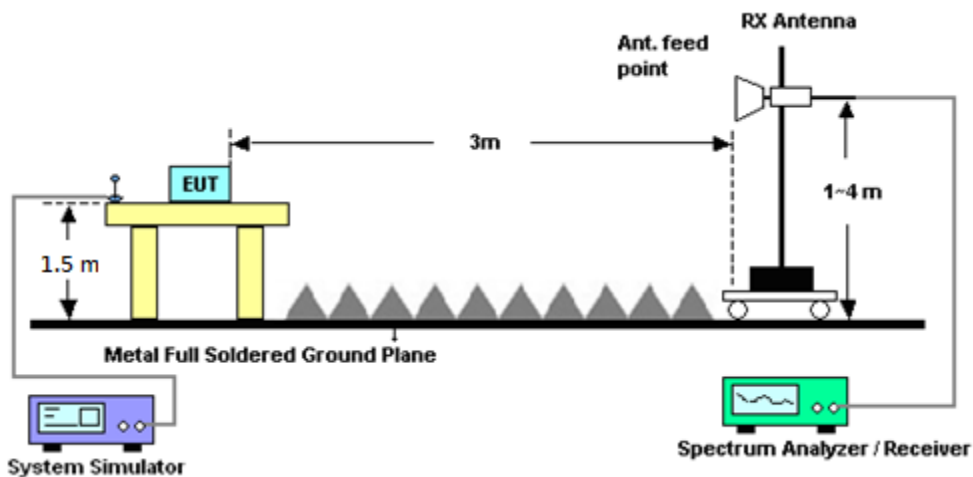

### 4.3 Test Result of Radiated Test

Please refer to Appendix B.



## 4.4 Field Strength of Spurious Radiation Measurement

### 4.4.1 Description of Field Strength of Spurious Radiated Measurement

The power of any emission outside of the authorized operating frequency ranges must be attenuated below the transmitter power (P) by a factor of at least  $43 + 10 \log (P)$  dB. The spectrum is scanned from 30 MHz up to a frequency including its 10th harmonic.

### 4.4.2 Test Procedures

1. The testing follows FCC KDB 971168 D01 v03 Section 5.8 and ANSI / TIA-603-E-2016 Section 2.2.12.
2. The EUT was placed on a rotatable wooden table 0.8 meters for frequency below 1GHz and 1.5 meter for frequency above 1GHz above the ground.
3. The EUT was set 3 meters from the receiving antenna, which was mounted on the antenna tower.
4. The table was rotated 360 degrees to determine the position of the highest spurious emission.
5. The height of the receiving antenna is varied between one meter and four meters to search for the maximum spurious emission for both horizontal and vertical polarizations.
6. Make the measurement with the spectrum analyzer's RBW = 1MHz, VBW = 3MHz, taking record of maximum spurious emission.
7. A horn antenna was substituted in place of the EUT and was driven by a signal generator.
8. Tune the output power of signal generator to the same emission level with EUT maximum spurious emission.
9. Taking the record of output power at antenna port.
10. Repeat step 7 to step 8 for another polarization.
11.  $EIRP \text{ (dBm)} = S.G. \text{ Power} - Tx \text{ Cable Loss} + Tx \text{ Antenna Gain}$
12.  $ERP \text{ (dBm)} = EIRP - 2.15$
13. The RF fundamental frequency should be excluded against the limit line in the operating frequency band.
14. The limit line is derived from  $43 + 10\log(P)$  dB below the transmitter power P(Watts)



## 5 List of Measuring Equipment

Instrument	Manufacturer	Model No.	Serial No.	Characteristics	Calibration Date	Test Date	Due Date	Remark
Hygrometer	Testo	608-H1	34893241	N/A	Mar. 20, 2017	Sep. 04, 2017~ Sep. 07, 2017	Mar. 19, 2018	Conducted (TH03-HY)
Spectrum Analyzer	Rohde & Schwarz	FSP30	101329	9kHz~30GHz	Jun. 29, 2017	Sep. 04, 2017 ~ Sep. 07, 2017	Jun. 28, 2018	Conducted (TH03-HY)
Temperature Chamber	ESPEC	SU-641	92013721	-30℃ ~70℃	Nov. 16, 2016	Sep. 04, 2017 ~ Sep. 07, 2017	Nov. 15, 2017	Conducted (TH03-HY)
Programmable Power Supply	GW Instek	PSS-2005	EL883644	Voltage:0~20V;Current:0~5A	Nov. 22, 2016	Sep. 04, 2017 ~ Sep. 07, 2017	Nov. 21, 2017	Conducted (TH03-HY)
Base Station (Measure)	Rohde & Schwarz	CMU200	117997	GSM / GPRS / WCDMA / CDMA	Aug. 20, 2017	Sep. 04, 2017 ~ Sep. 07, 2017	Aug. 19, 2018	Conducted (TH03-HY)
RF Cable	HUBER + SUHNER	SUCOFLEX 104	MY84209521	1GHz~26GHz	Dec. 02, 2016	Sep. 04, 2017 ~ Sep. 07, 2017	Dec. 01, 2017	Conducted (TH03-HY)
Bilog Antenna	TESEQ	CBL 6111D&008	35419&03	30MHz to 1GHz	Jan. 07, 2017	Aug. 30, 2017 ~ Sep. 05, 2017	Jan. 06, 2018	Radiation (03CH07-HY)
Double Ridge Horn Antenna	ESCO	3117	00075962	1GHz ~ 18GHz	Aug. 23, 2017	Aug. 30, 2017 ~ Sep. 05, 2017	Aug. 22, 2018	Radiation (03CH07-HY)
Horn Antenna	SCHWARZBECK	BBHA 9120 D	BBHA 9120 D 1212	1GHz ~ 18GHz	Mar. 17, 2017	Aug. 30, 2017 ~ Sep. 05, 2017	Mar. 16, 2018	Radiation (03CH07-HY)
SHF-EHF Horn Antenna	SCHWARZBECK	BBHA 9170	BBHA9170576	18GHz ~ 40GHz	Apr. 27, 2017	Aug. 30, 2017 ~ Sep. 05, 2017	Apr. 26, 2018	Radiation (03CH07-HY)
SHF-EHF Horn Antenna	SCHWARZBECK	BBHA 9170	BBHA9170584	18GHz- 40GHz	Nov. 08, 2016	Aug. 30, 2017 ~ Sep. 05, 2017	Nov. 07, 2017	Radiation (03CH07-HY)
Preamplifier	COM-POWER	PA-103A	161241	10MHz-1GHz	Mar. 14, 2017	Aug. 30, 2017 ~ Sep. 05, 2017	Mar. 13, 2018	Radiation (03CH07-HY)
Preamplifier	MITEQ	TTA1840-35 -HG	1871923	18GHz ~ 40GHz	Jul. 18, 2017	Aug. 30, 2017 ~ Sep. 05, 2017	Jul. 17, 2018	Radiation (03CH07-HY)
Preamplifier	MITEQ	AMF-7D-00 101800-30-1	1590075	1GHz ~ 18GHz	Apr. 25, 2017	Aug. 30, 2017 ~ Sep. 05, 2017	Apr. 24, 2018	Radiation (03CH07-HY)
Spectrum Analyzer	Agilent	N9010A	MY53470118	10Hz~44GHz	Apr. 17, 2017	Aug. 30, 2017 ~ Sep. 05, 2017	Apr. 16, 2018	Radiation (03CH07-HY)



Instrument	Manufacturer	Model No.	Serial No.	Characteristics	Calibration Date	Test Date	Due Date	Remark
Controller	ChainTek	Chaintek 3000	N/A	Control Turn table	N/A	Aug. 30, 2017 ~ Sep. 05, 2017	N/A	Radiation (03CH07-HY)
Controller	Max-Full	MF7802	MF780208368	Control Ant Mast	N/A	Aug. 30, 2017 ~ Sep. 05, 2017	N/A	Radiation (03CH07-HY)
Antenna Mast	Max-Full	MFA520BS	N/A	1m~4m	N/A	Aug. 30, 2017 ~ Sep. 05, 2017	N/A	Radiation (03CH07-HY)
Turn Table	ChainTek	Chaintek 3000	N/A	0~360 Degree	N/A	Aug. 30, 2017 ~ Sep. 05, 2017	N/A	Radiation (03CH07-HY)
Hygrometer	WISEWIND	410	BU5004	N/A	Mar. 20, 2017	Aug. 30, 2017 ~ Sep. 05, 2017	Mar. 19, 2018	Radiation (03CH07-HY)
Signal Generator	Rohde & Schwarz	SMF100A	101107	100kHz~40GHz	May 22, 2017	Aug. 30, 2017 ~ Sep. 05, 2017	May 21, 2018	Radiation (03CH07-HY)
RF Cable	HUBER + SUHNER	SUCOFLEX 104	Y84209521+M Y84209521	9KHz~30MHz	Jan. 03, 2017	Aug. 30, 2017 ~ Sep. 05, 2017	Jan. 02, 2018	Radiation (03CH07-HY)
RF Cable	HUBER + SUHNER	SUCOFLEX 104	MY84209521	30MHz~1GHz	Jan. 03, 2017	Aug. 30, 2017 ~ Sep. 05, 2017	Jan. 02, 2018	Radiation (03CH07-HY)
RF Cable	HUBER + SUHNER	SUCOFLEX 104	MY84209521+ MY84209521	1GHz~26GHz	Jan. 03, 2017	Aug. 30, 2017 ~ Sep. 05, 2017	Jan. 02, 2018	Radiation (03CH07-HY)
RF Cable	HUBER + SUHNER	SUCOFLEX 104	MY84209521+ MY84209521	26GHz~40GHz	Jan. 03, 2017	Aug. 30, 2017 ~ Sep. 05, 2017	Jan. 02, 2018	Radiation (03CH07-HY)
Filter	Microwave	H3G018G1	SN477220	3.0G High Pass	Nov. 22, 2016	Aug. 30, 2017 ~ Sep. 05, 2017	Nov. 21, 2017	Radiation (03CH07-HY)
Filter	Microwave	H1G013G1	SN477215	1.0G High Pass	Dec. 08, 2016	Aug. 30, 2017 ~ Sep. 05, 2017	Dec. 07, 2017	Radiation (03CH07-HY)
Filter	Wainwright	WLKS1200-12SS	SN2	1.2G Low Pass	Sep. 19, 2016	Aug. 30, 2017 ~ Sep. 05, 2017	Sep. 18, 2017	Radiation (03CH07-HY)
Notch Filter	Wainwright	WRCG824/849-40/8SS	SN35	CDMA 850	Nov. 22, 2016	Aug. 30, 2017 ~ Sep. 05, 2017	Nov. 21, 2017	Radiation (03CH07-HY)
Notch Filter	Wainwright	WRCT1850/1910-40/8S	SN21	1900	Nov. 22, 2016	Aug. 30, 2017 ~ Sep. 05, 2017	Nov. 21, 2017	Radiation (03CH07-HY)
Notch Filter	Wainwright	WRCT2500/2570-10/40-	SN1 R	LTE Band7	Aug. 24, 2017	Aug. 30, 2017 ~ Sep. 05, 2017	Aug. 23, 2018	Radiation (03CH07-HY)
Test Software	N/A	E3	6.2009-8-24 (sporton)	N/A	N/A	Aug. 30, 2017 ~ Sep. 05, 2017	N/A	Radiation (03CH07-HY)



## 6 Uncertainty of Evaluation

### Uncertainty of Radiated Emission Measurement (30 MHz ~ 1000 MHz)

Measuring Uncertainty for a Level of Confidence of 95% ( $U = 2Uc(y)$ )	3.05
---	------

### Uncertainty of Radiated Emission Measurement (1 GHz ~ 18 GHz)

Measuring Uncertainty for a Level of Confidence of 95% ( $U = 2Uc(y)$ )	3.44
---	------

### Uncertainty of Radiated Emission Measurement (1 GHz ~ 40 GHz)

Measuring Uncertainty for a Level of Confidence of 95% ( $U = 2Uc(y)$ )	3.95
---	------



## Appendix A. Test Results of Conducted Test

### Conducted Output Power(Average power)

Conducted Power (*Unit: dBm)						
Band	GSM850			GSM1900		
Channel	128	189	251	512	661	810
Frequency	824.2	836.4	848.8	1850.2	1880	1909.8
GSM	33.62	33.64	33.63	30.79	30.78	30.77
GPRS class 8	33.63	<b>33.65</b>	<b>33.65</b>	<b>30.80</b>	30.78	30.77
GPRS class 10	29.74	29.73	29.82	27.03	27.56	27.31
GPRS class 11	27.71	27.85	27.81	25.07	25.74	25.51
GPRS class 12	26.69	26.79	26.98	24.02	24.59	24.31
EGPRS class 8	<b>27.86</b>	27.81	27.75	<b>26.99</b>	26.86	26.87
EGPRS class 10	24.26	24.17	24.51	23.30	23.84	23.30
EGPRS class 11	22.55	22.57	22.61	21.21	21.63	20.98
EGPRS class 12	21.34	21.50	21.68	20.12	20.46	19.85

Conducted Power (*Unit: dBm)						
Band	WCDMA Band V			WCDMA Band II		
Channel	4132	4182	4233	9262	9400	9538
Frequency	826.4	836.4	846.6	1852.4	1880	1907.6
RMC 12.2K	24.50	24.60	<b>24.74</b>	22.35	<b>22.50</b>	22.36
HSDPA Subtest-1	23.64	23.86	23.87	21.42	21.07	20.63
HSDPA Subtest-2	23.85	23.78	23.78	21.50	21.14	20.80
HSDPA Subtest-3	23.18	23.34	23.44	20.87	20.67	20.31
HSDPA Subtest-4	23.18	23.20	23.29	20.94	20.65	20.13
HSUPA Subtest-1	22.05	22.07	22.20	19.99	19.60	19.57
HSUPA Subtest-2	21.66	21.79	21.87	19.50	19.07	18.70
HSUPA Subtest-3	22.55	22.77	22.80	20.42	20.10	19.87
HSUPA Subtest-4	21.31	21.19	21.42	18.73	18.58	18.21
HSUPA Subtest-5	23.52	23.82	23.84	21.39	21.26	20.78

Conducted Power (*Unit: dBm)			
Band	WCDMA Band IV		
Channel	1312	1413	1513
Frequency	1712.4	1732.6	1752.6
RMC 12.2K	24.50	24.63	<b>24.67</b>
HSDPA Subtest-1	23.46	23.53	23.79
HSDPA Subtest-2	23.44	23.48	23.95
HSDPA Subtest-3	22.83	23.11	23.31
HSDPA Subtest-4	23.03	23.08	23.41
HSUPA Subtest-1	22.06	22.18	22.38
HSUPA Subtest-2	21.43	21.43	21.70
HSUPA Subtest-3	22.26	22.32	22.65
HSUPA Subtest-4	20.97	21.02	21.17
HSUPA Subtest-5	23.40	23.17	23.70



# A1. GSM

## Peak-to-Average Ratio

Mode	GSM850		Limit: 13dB
Mod.	GPRS class 8	EDGE class 8	Result
Lowest CH	0.20	2.88	PASS
Middle CH	0.20	2.92	
Highest CH	0.24	3.00	

Mode	GSM1900		Limit: 13dB
Mod.	GPRS class 8	EDGE class 8	Result
Lowest CH	0.32	2.44	PASS
Middle CH	0.28	2.44	
Highest CH	0.28	2.52	





GSM850 (GPRS class 8)	GSM850 (EDGE class 8)																
<p align="center"><b>Lowest Channel</b></p> <p>Ref: 35 dBm    Att: 30 dB    AQT: 3.125 ms</p> <p>Center: 824.2 MHz    2 dB/</p> <p>Complementary Cumulative Distribution Function (100000 samples)</p> <p>Trace 1</p> <p>Mean: 29.07 dBm Peak: 29.33 dBm Crest: 0.25 dB</p> <table border="1"> <tr><td>10 %</td><td>0.20 dB</td></tr> <tr><td>1 %</td><td>0.20 dB</td></tr> <tr><td>.1 %</td><td>0.20 dB</td></tr> <tr><td>.01 %</td><td>0.20 dB</td></tr> </table> <p>Date: 7.SEP.2017 01:08:16</p>	10 %	0.20 dB	1 %	0.20 dB	.1 %	0.20 dB	.01 %	0.20 dB	<p align="center"><b>Lowest Channel</b></p> <p>Ref: 35 dBm    Att: 30 dB    AQT: 3.125 ms</p> <p>Center: 824.2 MHz    2 dB/</p> <p>Complementary Cumulative Distribution Function (100000 samples)</p> <p>Trace 1</p> <p>Mean: 27.51 dBm Peak: 30.45 dBm Crest: 2.94 dB</p> <table border="1"> <tr><td>10 %</td><td>2.40 dB</td></tr> <tr><td>1 %</td><td>2.80 dB</td></tr> <tr><td>.1 %</td><td>2.88 dB</td></tr> <tr><td>.01 %</td><td>2.96 dB</td></tr> </table> <p>Date: 7.SEP.2017 10:10:56</p>	10 %	2.40 dB	1 %	2.80 dB	.1 %	2.88 dB	.01 %	2.96 dB
10 %	0.20 dB																
1 %	0.20 dB																
.1 %	0.20 dB																
.01 %	0.20 dB																
10 %	2.40 dB																
1 %	2.80 dB																
.1 %	2.88 dB																
.01 %	2.96 dB																
<p align="center"><b>Middle Channel</b></p> <p>Ref: 35 dBm    Att: 30 dB    AQT: 3.125 ms</p> <p>Center: 836.4 MHz    2 dB/</p> <p>Complementary Cumulative Distribution Function (100000 samples)</p> <p>Trace 1</p> <p>Mean: 29.10 dBm Peak: 29.33 dBm Crest: 0.23 dB</p> <table border="1"> <tr><td>10 %</td><td>0.16 dB</td></tr> <tr><td>1 %</td><td>0.16 dB</td></tr> <tr><td>.1 %</td><td>0.20 dB</td></tr> <tr><td>.01 %</td><td>0.24 dB</td></tr> </table> <p>Date: 7.SEP.2017 01:08:40</p>	10 %	0.16 dB	1 %	0.16 dB	.1 %	0.20 dB	.01 %	0.24 dB	<p align="center"><b>Middle Channel</b></p> <p>Ref: 35 dBm    Att: 30 dB    AQT: 3.125 ms</p> <p>Center: 836.4 MHz    2 dB/</p> <p>Complementary Cumulative Distribution Function (100000 samples)</p> <p>Trace 1</p> <p>Mean: 27.48 dBm Peak: 30.45 dBm Crest: 2.97 dB</p> <table border="1"> <tr><td>10 %</td><td>2.44 dB</td></tr> <tr><td>1 %</td><td>2.84 dB</td></tr> <tr><td>.1 %</td><td>2.92 dB</td></tr> <tr><td>.01 %</td><td>2.92 dB</td></tr> </table> <p>Date: 7.SEP.2017 10:11:18</p>	10 %	2.44 dB	1 %	2.84 dB	.1 %	2.92 dB	.01 %	2.92 dB
10 %	0.16 dB																
1 %	0.16 dB																
.1 %	0.20 dB																
.01 %	0.24 dB																
10 %	2.44 dB																
1 %	2.84 dB																
.1 %	2.92 dB																
.01 %	2.92 dB																
<p align="center"><b>Highest Channel</b></p> <p>Ref: 35 dBm    Att: 30 dB    AQT: 3.125 ms</p> <p>Center: 848.8 MHz    2 dB/</p> <p>Complementary Cumulative Distribution Function (100000 samples)</p> <p>Trace 1</p> <p>Mean: 29.17 dBm Peak: 29.40 dBm Crest: 0.23 dB</p> <table border="1"> <tr><td>10 %</td><td>0.16 dB</td></tr> <tr><td>1 %</td><td>0.20 dB</td></tr> <tr><td>.1 %</td><td>0.24 dB</td></tr> <tr><td>.01 %</td><td>0.24 dB</td></tr> </table> <p>Date: 7.SEP.2017 01:09:08</p>	10 %	0.16 dB	1 %	0.20 dB	.1 %	0.24 dB	.01 %	0.24 dB	<p align="center"><b>Highest Channel</b></p> <p>Ref: 35 dBm    Att: 30 dB    AQT: 3.125 ms</p> <p>Center: 848.8 MHz    2 dB/</p> <p>Complementary Cumulative Distribution Function (100000 samples)</p> <p>Trace 1</p> <p>Mean: 27.42 dBm Peak: 30.45 dBm Crest: 3.04 dB</p> <table border="1"> <tr><td>10 %</td><td>2.56 dB</td></tr> <tr><td>1 %</td><td>2.92 dB</td></tr> <tr><td>.1 %</td><td>3.00 dB</td></tr> <tr><td>.01 %</td><td>3.04 dB</td></tr> </table> <p>Date: 7.SEP.2017 10:11:38</p>	10 %	2.56 dB	1 %	2.92 dB	.1 %	3.00 dB	.01 %	3.04 dB
10 %	0.16 dB																
1 %	0.20 dB																
.1 %	0.24 dB																
.01 %	0.24 dB																
10 %	2.56 dB																
1 %	2.92 dB																
.1 %	3.00 dB																
.01 %	3.04 dB																

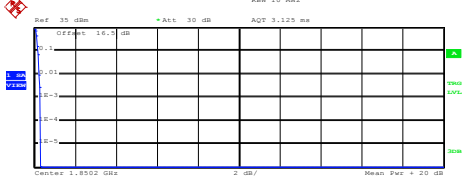
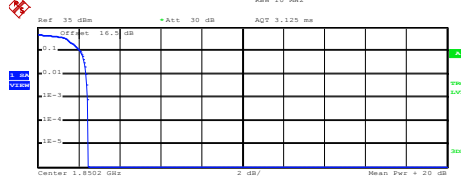
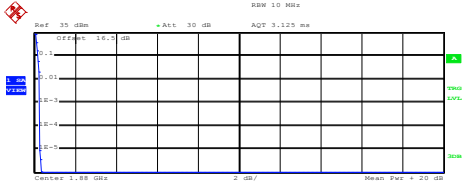
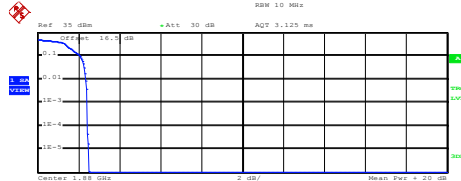
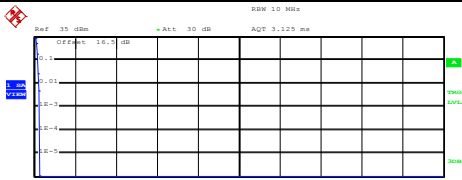
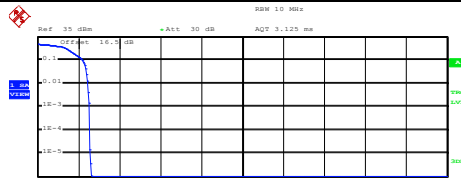

GSM1900 (GPRS class 8)	GSM1900 (EDGE class 8)																
<p align="center"><b>Lowest Channel</b></p>  <p>Ref: 35 dBm    *Att: 30 dB    RBW: 10 MHz    AQT: 3.125 ms</p> <p>Center: 1.8502 GHz    2 dB/    Mean Pwr: +20 dB</p> <p>Complementary Cumulative Distribution Function (100000 samples)</p> <p>Trace 1</p> <p>Mean: 30.51 dBm Peak: 30.81 dBm Crest: 0.30 dB</p> <table border="1"> <tr><td>10 %</td><td>0.20 dB</td></tr> <tr><td>1 %</td><td>0.24 dB</td></tr> <tr><td>.1 %</td><td>0.32 dB</td></tr> <tr><td>.01 %</td><td>0.32 dB</td></tr> </table> <p>Date: 4.SEP.2017 23:19:52</p>	10 %	0.20 dB	1 %	0.24 dB	.1 %	0.32 dB	.01 %	0.32 dB	<p align="center"><b>Lowest Channel</b></p>  <p>Ref: 35 dBm    *Att: 30 dB    RBW: 10 MHz    AQT: 3.125 ms</p> <p>Center: 1.8502 GHz    2 dB/    Mean Pwr: +20 dB</p> <p>Complementary Cumulative Distribution Function (100000 samples)</p> <p>Trace 1</p> <p>Mean: 26.67 dBm Peak: 29.11 dBm Crest: 2.45 dB</p> <table border="1"> <tr><td>10 %</td><td>2.08 dB</td></tr> <tr><td>1 %</td><td>2.36 dB</td></tr> <tr><td>.1 %</td><td>2.44 dB</td></tr> <tr><td>.01 %</td><td>2.48 dB</td></tr> </table> <p>Date: 4.SEP.2017 23:40:52</p>	10 %	2.08 dB	1 %	2.36 dB	.1 %	2.44 dB	.01 %	2.48 dB
10 %	0.20 dB																
1 %	0.24 dB																
.1 %	0.32 dB																
.01 %	0.32 dB																
10 %	2.08 dB																
1 %	2.36 dB																
.1 %	2.44 dB																
.01 %	2.48 dB																
<p align="center"><b>Middle Channel</b></p>  <p>Ref: 35 dBm    *Att: 30 dB    RBW: 10 MHz    AQT: 3.125 ms</p> <p>Center: 1.88 GHz    2 dB/    Mean Pwr: +20 dB</p> <p>Complementary Cumulative Distribution Function (100000 samples)</p> <p>Trace 1</p> <p>Mean: 30.46 dBm Peak: 30.81 dBm Crest: 0.35 dB</p> <table border="1"> <tr><td>10 %</td><td>0.20 dB</td></tr> <tr><td>1 %</td><td>0.28 dB</td></tr> <tr><td>.1 %</td><td>0.28 dB</td></tr> <tr><td>.01 %</td><td>0.28 dB</td></tr> </table> <p>Date: 4.SEP.2017 23:20:12</p>	10 %	0.20 dB	1 %	0.28 dB	.1 %	0.28 dB	.01 %	0.28 dB	<p align="center"><b>Middle Channel</b></p>  <p>Ref: 35 dBm    *Att: 30 dB    RBW: 10 MHz    AQT: 3.125 ms</p> <p>Center: 1.88 GHz    2 dB/    Mean Pwr: +20 dB</p> <p>Complementary Cumulative Distribution Function (100000 samples)</p> <p>Trace 1</p> <p>Mean: 26.47 dBm Peak: 28.97 dBm Crest: 2.50 dB</p> <table border="1"> <tr><td>10 %</td><td>2.08 dB</td></tr> <tr><td>1 %</td><td>2.36 dB</td></tr> <tr><td>.1 %</td><td>2.44 dB</td></tr> <tr><td>.01 %</td><td>2.44 dB</td></tr> </table> <p>Date: 4.SEP.2017 23:41:09</p>	10 %	2.08 dB	1 %	2.36 dB	.1 %	2.44 dB	.01 %	2.44 dB
10 %	0.20 dB																
1 %	0.28 dB																
.1 %	0.28 dB																
.01 %	0.28 dB																
10 %	2.08 dB																
1 %	2.36 dB																
.1 %	2.44 dB																
.01 %	2.44 dB																
<p align="center"><b>Highest Channel</b></p>  <p>Ref: 35 dBm    *Att: 30 dB    RBW: 10 MHz    AQT: 3.125 ms</p> <p>Center: 1.9098 GHz    2 dB/    Mean Pwr: +20 dB</p> <p>Complementary Cumulative Distribution Function (100000 samples)</p> <p>Trace 1</p> <p>Mean: 30.13 dBm Peak: 30.38 dBm Crest: 0.25 dB</p> <table border="1"> <tr><td>10 %</td><td>0.20 dB</td></tr> <tr><td>1 %</td><td>0.24 dB</td></tr> <tr><td>.1 %</td><td>0.28 dB</td></tr> <tr><td>.01 %</td><td>0.28 dB</td></tr> </table> <p>Date: 4.SEP.2017 23:20:37</p>	10 %	0.20 dB	1 %	0.24 dB	.1 %	0.28 dB	.01 %	0.28 dB	<p align="center"><b>Highest Channel</b></p>  <p>Ref: 35 dBm    *Att: 30 dB    RBW: 10 MHz    AQT: 3.125 ms</p> <p>Center: 1.9098 GHz    2 dB/    Mean Pwr: +20 dB</p> <p>Complementary Cumulative Distribution Function (100000 samples)</p> <p>Trace 1</p> <p>Mean: 25.87 dBm Peak: 28.48 dBm Crest: 2.61 dB</p> <table border="1"> <tr><td>10 %</td><td>2.20 dB</td></tr> <tr><td>1 %</td><td>2.44 dB</td></tr> <tr><td>.1 %</td><td>2.52 dB</td></tr> <tr><td>.01 %</td><td>2.56 dB</td></tr> </table> <p>Date: 4.SEP.2017 23:41:23</p>	10 %	2.20 dB	1 %	2.44 dB	.1 %	2.52 dB	.01 %	2.56 dB
10 %	0.20 dB																
1 %	0.24 dB																
.1 %	0.28 dB																
.01 %	0.28 dB																
10 %	2.20 dB																
1 %	2.44 dB																
.1 %	2.52 dB																
.01 %	2.56 dB																



**26dB Bandwidth**

Mode	GSM850 : 26dB BW(MHz)	
Mod.	GPRS class 8	EDGE class 8
Lowest CH	0.314	0.301
Middle CH	0.311	0.311
Highest CH	0.313	0.308

Mode	GSM1900 : 26dB BW(MHz)	
Mod.	GPRS class 8	EDGE class 8
Lowest CH	0.305	0.315
Middle CH	0.309	0.300
Highest CH	0.311	0.307

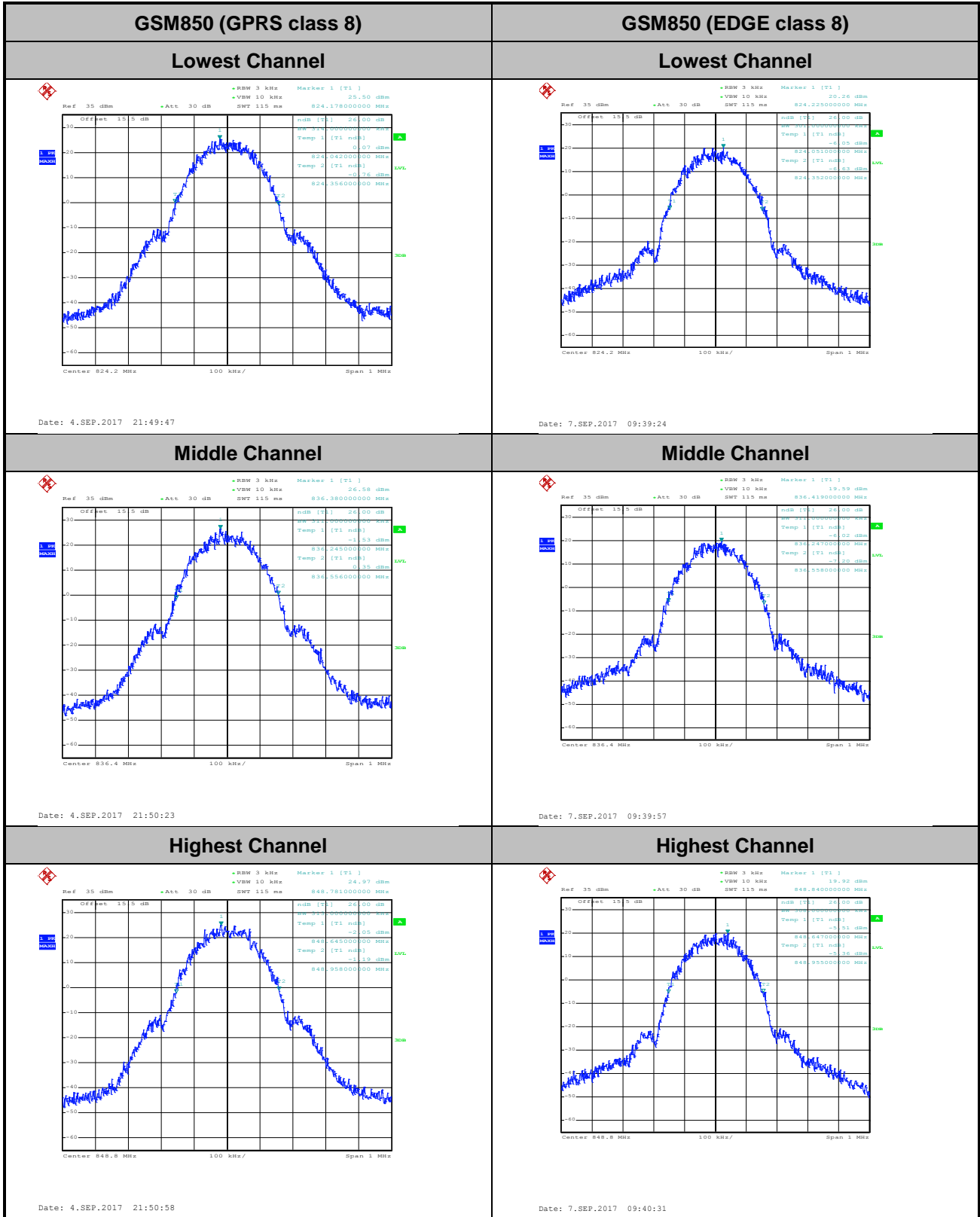

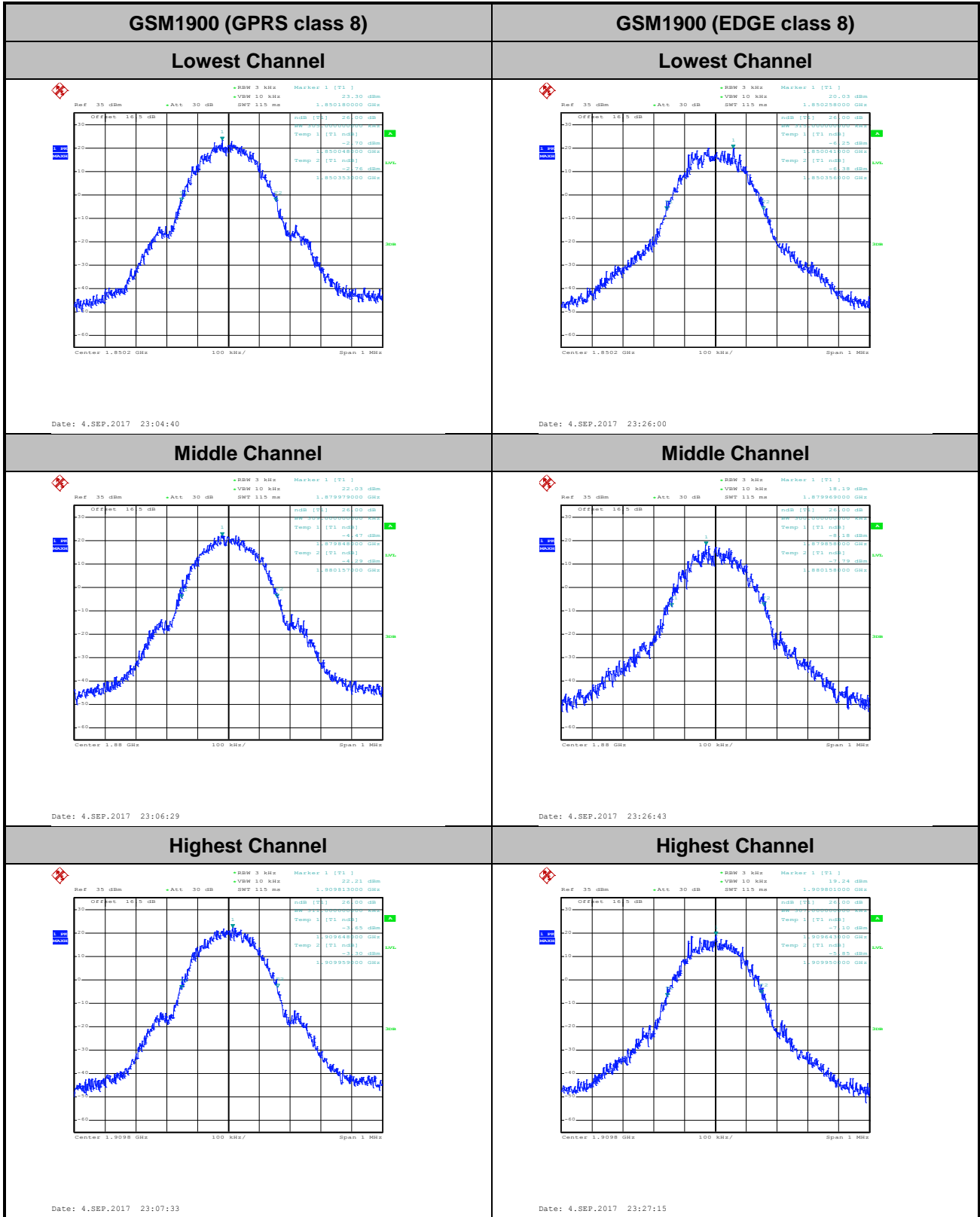



**Occupied Bandwidth**

Mode	GSM850 : 99%OBW(MHz)	
Mod.	GPRS class 8	EDGE class 8
Lowest CH	0.246	0.251
Middle CH	0.248	0.253
Highest CH	0.242	0.254

Mode	GSM1900 : 99%OBW(MHz)	
Mod.	GPRS class 8	EDGE class 8
Lowest CH	0.248	0.255
Middle CH	0.245	0.254
Highest CH	0.247	0.252

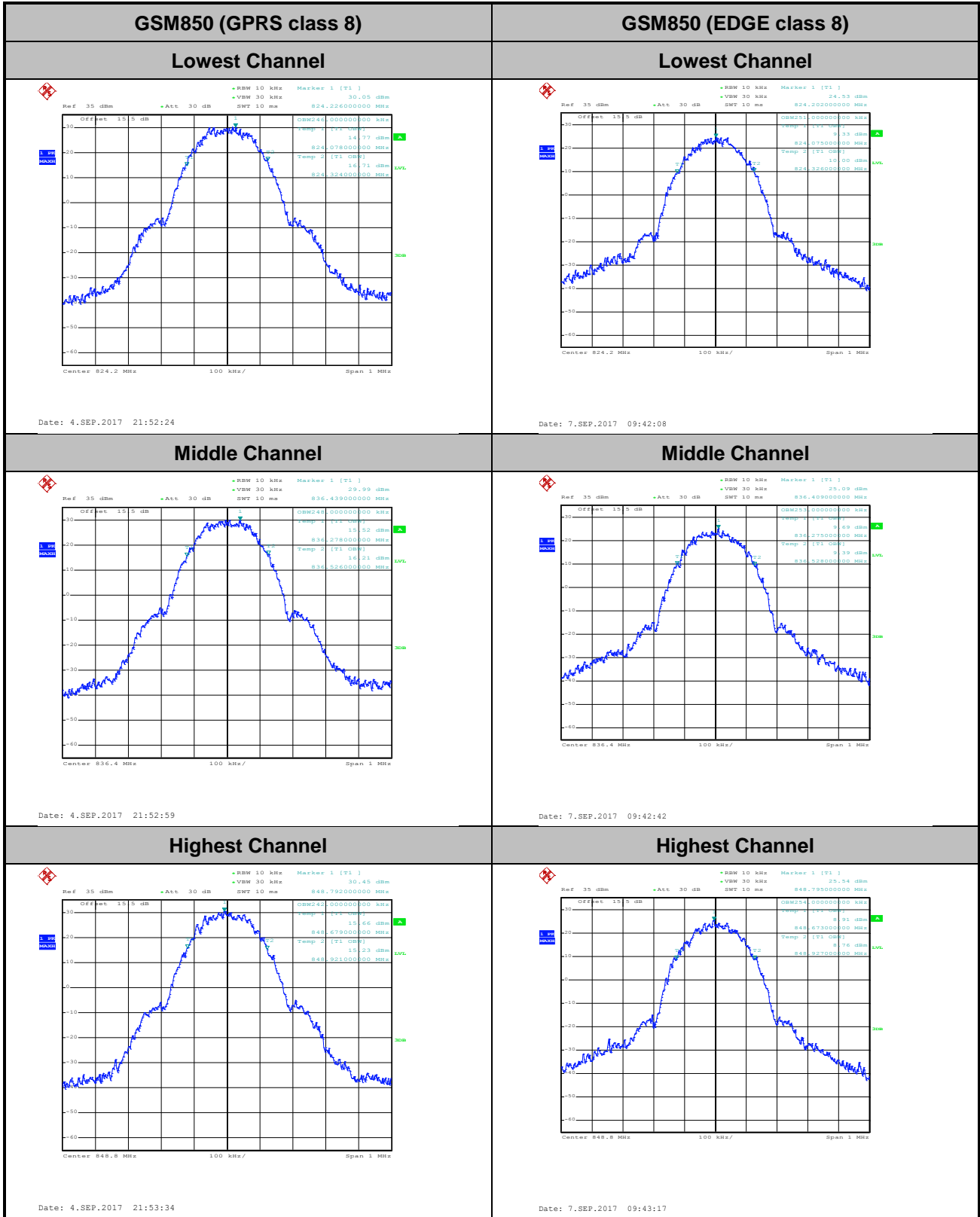

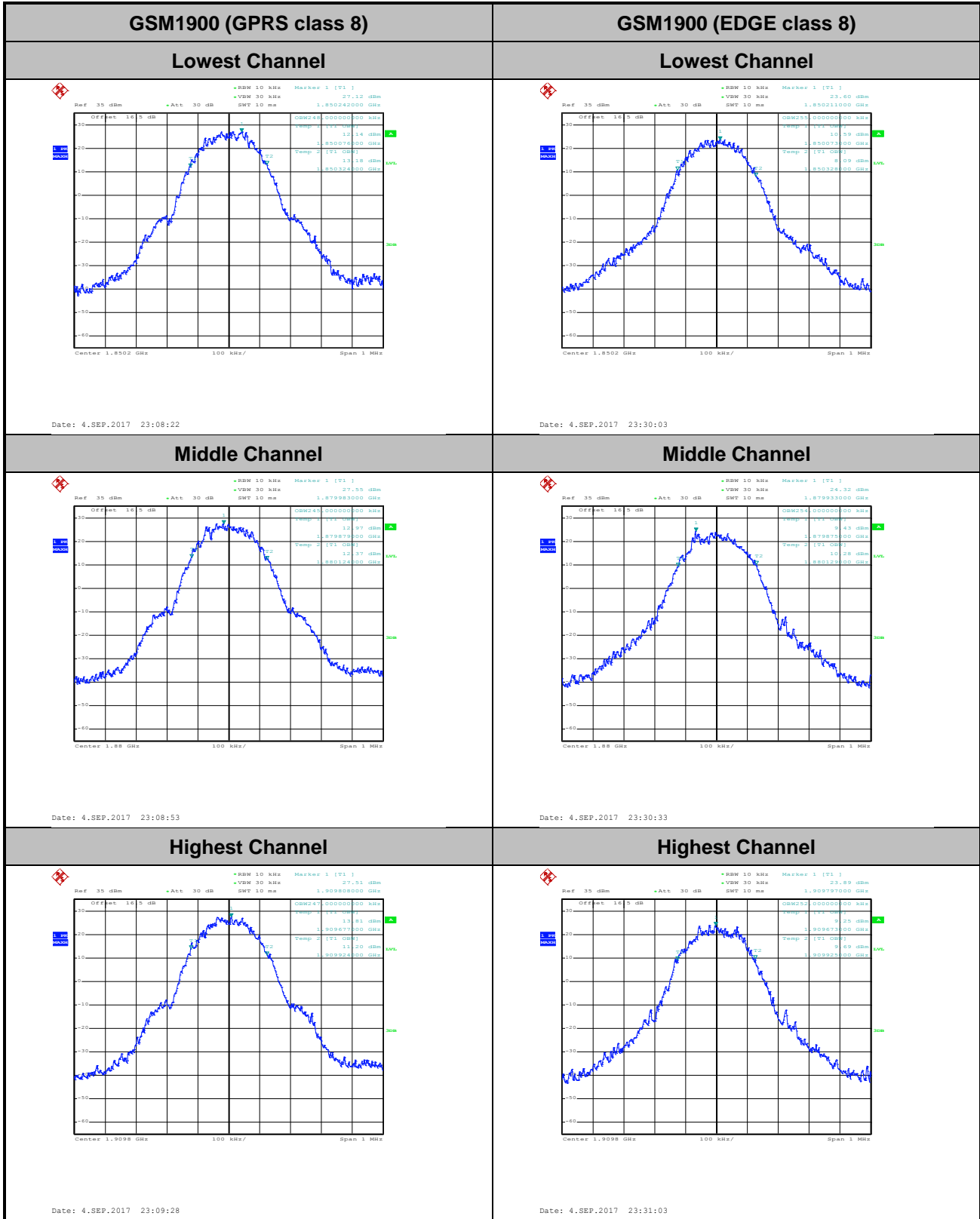





**Conducted Band Edge**



GSM850 (GPRS class 8)

Lowest Band Edge

Highest Band Edge

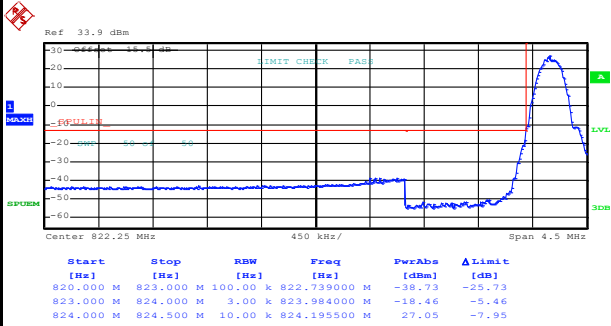

Date: 4.SEP.2017 21:55:26

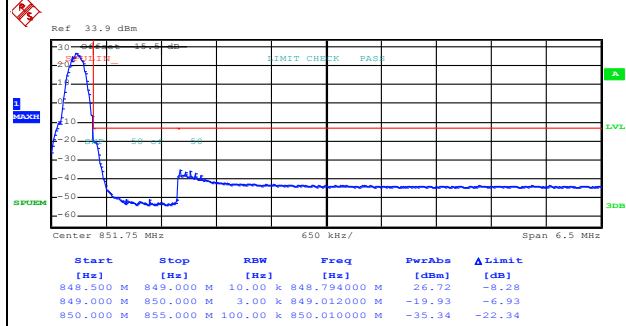

Date: 4.SEP.2017 21:57:01

GSM850 (EDGE class 8)

Lowest Band Edge

Highest Band Edge

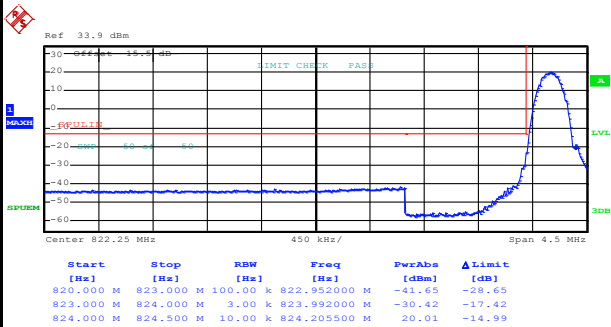

Date: 7.SEP.2017 09:45:05

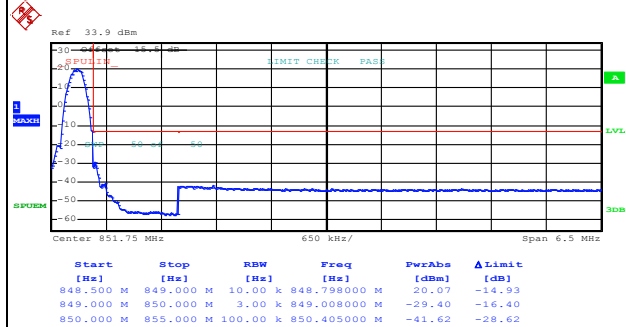

Date: 7.SEP.2017 09:46:39



GSM1900 (GPRS class 8)

Lowest Band Edge

Highest Band Edge

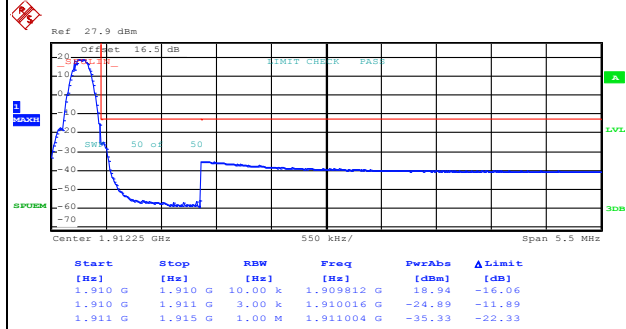
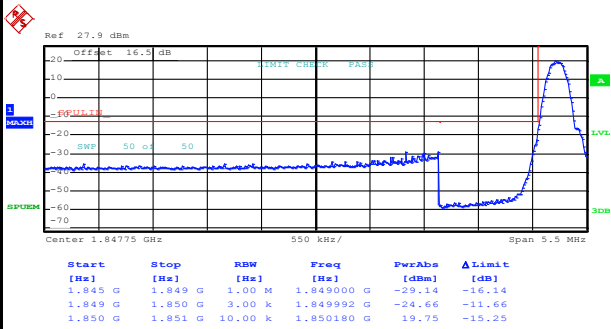

Date: 6.SEP.2017 22:41:49

Date: 6.SEP.2017 22:43:16

GSM1900 (EDGE class 8)

Lowest Band Edge

Highest Band Edge

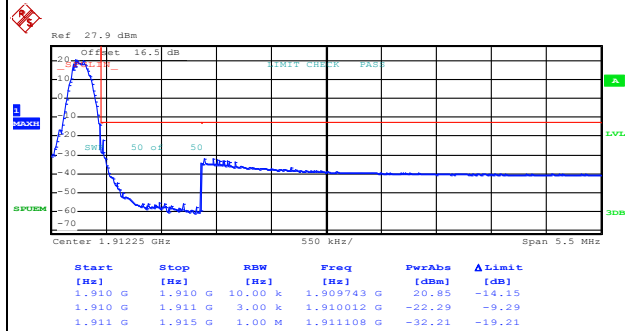
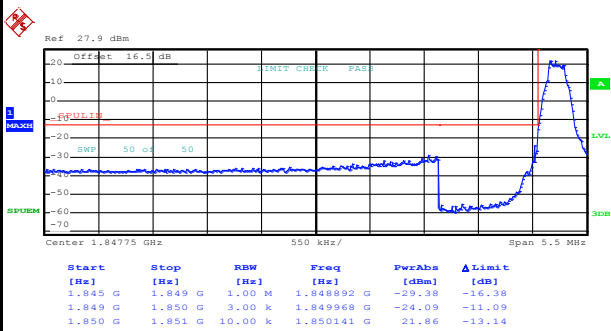

Date: 4.SEP.2017 23:33:08

Date: 4.SEP.2017 23:34:38



**Conducted Spurious Emission**

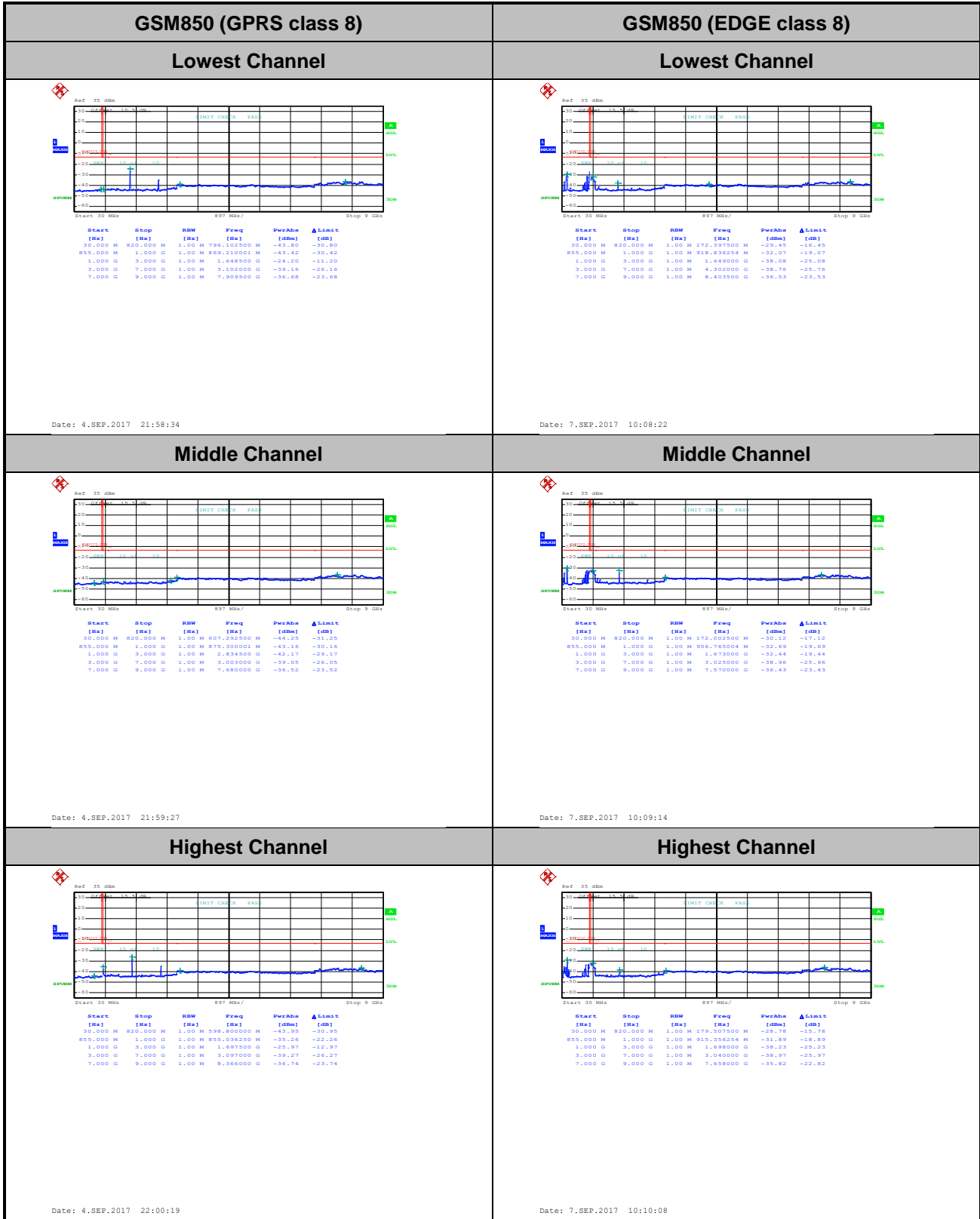

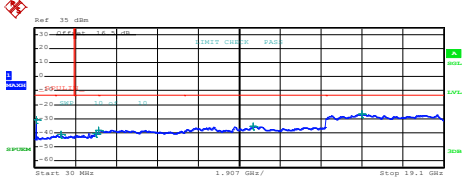
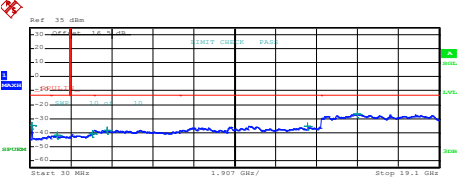
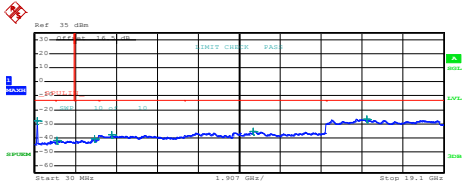
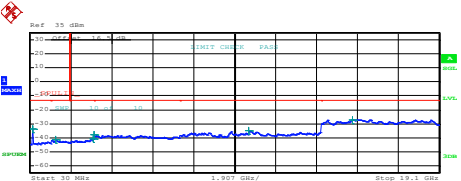
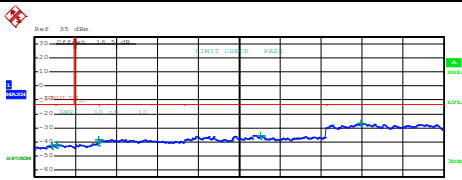
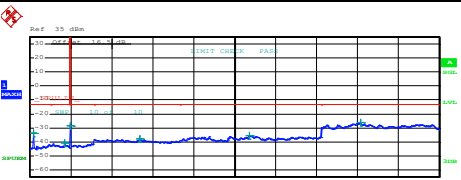

GSM1900 (GPRS class 8)	GSM1900 (EDGE class 8)																																																																																				
Lowest Channel	Lowest Channel																																																																																				
 <table border="1" data-bbox="239 571 638 672"> <thead> <tr> <th>Start [Hz]</th> <th>Stop [Hz]</th> <th>RBW [Hz]</th> <th>Freq [Hz]</th> <th>PwrAve [dBm]</th> <th>ΔLimit [dB]</th> </tr> </thead> <tbody> <tr><td>30.0000 M</td><td>1.0000 G</td><td>1.000 M</td><td>111.965000 M</td><td>-30.83</td><td>-27.83</td></tr> <tr><td>1.0000 G</td><td>1.845 G</td><td>1.000 M</td><td>1.2932164 G</td><td>-41.04</td><td>-28.04</td></tr> <tr><td>1.845 G</td><td>3.0000 G</td><td>1.000 M</td><td>2.9228799 G</td><td>-40.82</td><td>-27.82</td></tr> <tr><td>3.0000 G</td><td>7.0000 G</td><td>1.000 M</td><td>3.0060000 G</td><td>-38.26</td><td>-25.26</td></tr> <tr><td>7.0000 G</td><td>13.6000 G</td><td>1.000 M</td><td>10.224100 G</td><td>-35.19</td><td>-22.19</td></tr> <tr><td>13.6000 G</td><td>19.1000 G</td><td>1.000 M</td><td>15.277500 G</td><td>-26.86</td><td>-13.86</td></tr> </tbody> </table> <p>Date: 4.SEP.2017 23:17:19</p>	Start [Hz]	Stop [Hz]	RBW [Hz]	Freq [Hz]	PwrAve [dBm]	ΔLimit [dB]	30.0000 M	1.0000 G	1.000 M	111.965000 M	-30.83	-27.83	1.0000 G	1.845 G	1.000 M	1.2932164 G	-41.04	-28.04	1.845 G	3.0000 G	1.000 M	2.9228799 G	-40.82	-27.82	3.0000 G	7.0000 G	1.000 M	3.0060000 G	-38.26	-25.26	7.0000 G	13.6000 G	1.000 M	10.224100 G	-35.19	-22.19	13.6000 G	19.1000 G	1.000 M	15.277500 G	-26.86	-13.86	 <table border="1" data-bbox="893 571 1292 672"> <thead> <tr> <th>Start [Hz]</th> <th>Stop [Hz]</th> <th>RBW [Hz]</th> <th>Freq [Hz]</th> <th>PwrAve [dBm]</th> <th>ΔLimit [dB]</th> </tr> </thead> <tbody> <tr><td>30.0000 M</td><td>1.0000 G</td><td>1.000 M</td><td>111.965000 M</td><td>-31.92</td><td>-21.92</td></tr> <tr><td>1.0000 G</td><td>1.845 G</td><td>1.000 M</td><td>1.2946974 G</td><td>-41.84</td><td>-28.84</td></tr> <tr><td>1.845 G</td><td>3.0000 G</td><td>1.000 M</td><td>2.9228847 G</td><td>-40.84</td><td>-27.84</td></tr> <tr><td>3.0000 G</td><td>7.0000 G</td><td>1.000 M</td><td>3.0050000 G</td><td>-38.22</td><td>-25.22</td></tr> <tr><td>7.0000 G</td><td>13.6000 G</td><td>1.000 M</td><td>10.2963925 G</td><td>-35.43</td><td>-22.43</td></tr> <tr><td>13.6000 G</td><td>19.1000 G</td><td>1.000 M</td><td>15.3036250 G</td><td>-26.85</td><td>-13.85</td></tr> </tbody> </table> <p>Date: 4.SEP.2017 23:36:03</p>	Start [Hz]	Stop [Hz]	RBW [Hz]	Freq [Hz]	PwrAve [dBm]	ΔLimit [dB]	30.0000 M	1.0000 G	1.000 M	111.965000 M	-31.92	-21.92	1.0000 G	1.845 G	1.000 M	1.2946974 G	-41.84	-28.84	1.845 G	3.0000 G	1.000 M	2.9228847 G	-40.84	-27.84	3.0000 G	7.0000 G	1.000 M	3.0050000 G	-38.22	-25.22	7.0000 G	13.6000 G	1.000 M	10.2963925 G	-35.43	-22.43	13.6000 G	19.1000 G	1.000 M	15.3036250 G	-26.85	-13.85
Start [Hz]	Stop [Hz]	RBW [Hz]	Freq [Hz]	PwrAve [dBm]	ΔLimit [dB]																																																																																
30.0000 M	1.0000 G	1.000 M	111.965000 M	-30.83	-27.83																																																																																
1.0000 G	1.845 G	1.000 M	1.2932164 G	-41.04	-28.04																																																																																
1.845 G	3.0000 G	1.000 M	2.9228799 G	-40.82	-27.82																																																																																
3.0000 G	7.0000 G	1.000 M	3.0060000 G	-38.26	-25.26																																																																																
7.0000 G	13.6000 G	1.000 M	10.224100 G	-35.19	-22.19																																																																																
13.6000 G	19.1000 G	1.000 M	15.277500 G	-26.86	-13.86																																																																																
Start [Hz]	Stop [Hz]	RBW [Hz]	Freq [Hz]	PwrAve [dBm]	ΔLimit [dB]																																																																																
30.0000 M	1.0000 G	1.000 M	111.965000 M	-31.92	-21.92																																																																																
1.0000 G	1.845 G	1.000 M	1.2946974 G	-41.84	-28.84																																																																																
1.845 G	3.0000 G	1.000 M	2.9228847 G	-40.84	-27.84																																																																																
3.0000 G	7.0000 G	1.000 M	3.0050000 G	-38.22	-25.22																																																																																
7.0000 G	13.6000 G	1.000 M	10.2963925 G	-35.43	-22.43																																																																																
13.6000 G	19.1000 G	1.000 M	15.3036250 G	-26.85	-13.85																																																																																
Middle Channel	Middle Channel																																																																																				
 <table border="1" data-bbox="239 1086 638 1187"> <thead> <tr> <th>Start [Hz]</th> <th>Stop [Hz]</th> <th>RBW [Hz]</th> <th>Freq [Hz]</th> <th>PwrAve [dBm]</th> <th>ΔLimit [dB]</th> </tr> </thead> <tbody> <tr><td>30.0000 M</td><td>1.0000 G</td><td>1.000 M</td><td>141.792500 M</td><td>-27.89</td><td>-14.89</td></tr> <tr><td>1.0000 G</td><td>1.845 G</td><td>1.000 M</td><td>1.0708399 G</td><td>-41.68</td><td>-28.68</td></tr> <tr><td>1.845 G</td><td>3.0000 G</td><td>1.000 M</td><td>2.8109399 G</td><td>-40.93</td><td>-27.93</td></tr> <tr><td>3.0000 G</td><td>7.0000 G</td><td>1.000 M</td><td>3.0110000 G</td><td>-37.67</td><td>-24.67</td></tr> <tr><td>7.0000 G</td><td>13.6000 G</td><td>1.000 M</td><td>10.2142000 G</td><td>-35.30</td><td>-22.30</td></tr> <tr><td>13.6000 G</td><td>19.1000 G</td><td>1.000 M</td><td>15.305062 G</td><td>-26.95</td><td>-13.95</td></tr> </tbody> </table> <p>Date: 4.SEP.2017 23:18:13</p>	Start [Hz]	Stop [Hz]	RBW [Hz]	Freq [Hz]	PwrAve [dBm]	ΔLimit [dB]	30.0000 M	1.0000 G	1.000 M	141.792500 M	-27.89	-14.89	1.0000 G	1.845 G	1.000 M	1.0708399 G	-41.68	-28.68	1.845 G	3.0000 G	1.000 M	2.8109399 G	-40.93	-27.93	3.0000 G	7.0000 G	1.000 M	3.0110000 G	-37.67	-24.67	7.0000 G	13.6000 G	1.000 M	10.2142000 G	-35.30	-22.30	13.6000 G	19.1000 G	1.000 M	15.305062 G	-26.95	-13.95	 <table border="1" data-bbox="893 1086 1292 1187"> <thead> <tr> <th>Start [Hz]</th> <th>Stop [Hz]</th> <th>RBW [Hz]</th> <th>Freq [Hz]</th> <th>PwrAve [dBm]</th> <th>ΔLimit [dB]</th> </tr> </thead> <tbody> <tr><td>30.0000 M</td><td>1.0000 G</td><td>1.000 M</td><td>141.792500 M</td><td>-33.54</td><td>-20.54</td></tr> <tr><td>1.0000 G</td><td>1.845 G</td><td>1.000 M</td><td>1.0223714 G</td><td>-41.81</td><td>-28.81</td></tr> <tr><td>1.845 G</td><td>3.0000 G</td><td>1.000 M</td><td>2.962296 G</td><td>-40.82</td><td>-27.82</td></tr> <tr><td>3.0000 G</td><td>7.0000 G</td><td>1.000 M</td><td>3.0190000 G</td><td>-38.04</td><td>-25.04</td></tr> <tr><td>7.0000 G</td><td>13.6000 G</td><td>1.000 M</td><td>10.223799 G</td><td>-35.05</td><td>-22.05</td></tr> <tr><td>13.6000 G</td><td>19.1000 G</td><td>1.000 M</td><td>15.067125 G</td><td>-27.02</td><td>-14.02</td></tr> </tbody> </table> <p>Date: 4.SEP.2017 23:36:50</p>	Start [Hz]	Stop [Hz]	RBW [Hz]	Freq [Hz]	PwrAve [dBm]	ΔLimit [dB]	30.0000 M	1.0000 G	1.000 M	141.792500 M	-33.54	-20.54	1.0000 G	1.845 G	1.000 M	1.0223714 G	-41.81	-28.81	1.845 G	3.0000 G	1.000 M	2.962296 G	-40.82	-27.82	3.0000 G	7.0000 G	1.000 M	3.0190000 G	-38.04	-25.04	7.0000 G	13.6000 G	1.000 M	10.223799 G	-35.05	-22.05	13.6000 G	19.1000 G	1.000 M	15.067125 G	-27.02	-14.02
Start [Hz]	Stop [Hz]	RBW [Hz]	Freq [Hz]	PwrAve [dBm]	ΔLimit [dB]																																																																																
30.0000 M	1.0000 G	1.000 M	141.792500 M	-27.89	-14.89																																																																																
1.0000 G	1.845 G	1.000 M	1.0708399 G	-41.68	-28.68																																																																																
1.845 G	3.0000 G	1.000 M	2.8109399 G	-40.93	-27.93																																																																																
3.0000 G	7.0000 G	1.000 M	3.0110000 G	-37.67	-24.67																																																																																
7.0000 G	13.6000 G	1.000 M	10.2142000 G	-35.30	-22.30																																																																																
13.6000 G	19.1000 G	1.000 M	15.305062 G	-26.95	-13.95																																																																																
Start [Hz]	Stop [Hz]	RBW [Hz]	Freq [Hz]	PwrAve [dBm]	ΔLimit [dB]																																																																																
30.0000 M	1.0000 G	1.000 M	141.792500 M	-33.54	-20.54																																																																																
1.0000 G	1.845 G	1.000 M	1.0223714 G	-41.81	-28.81																																																																																
1.845 G	3.0000 G	1.000 M	2.962296 G	-40.82	-27.82																																																																																
3.0000 G	7.0000 G	1.000 M	3.0190000 G	-38.04	-25.04																																																																																
7.0000 G	13.6000 G	1.000 M	10.223799 G	-35.05	-22.05																																																																																
13.6000 G	19.1000 G	1.000 M	15.067125 G	-27.02	-14.02																																																																																
Highest Channel	Highest Channel																																																																																				
 <table border="1" data-bbox="239 1601 638 1702"> <thead> <tr> <th>Start [Hz]</th> <th>Stop [Hz]</th> <th>RBW [Hz]</th> <th>Freq [Hz]</th> <th>PwrAve [dBm]</th> <th>ΔLimit [dB]</th> </tr> </thead> <tbody> <tr><td>30.0000 M</td><td>1.0000 G</td><td>1.000 M</td><td>820.307500 M</td><td>-42.76</td><td>-29.76</td></tr> <tr><td>1.0000 G</td><td>1.845 G</td><td>1.000 M</td><td>1.0669390 G</td><td>-41.81</td><td>-28.81</td></tr> <tr><td>1.845 G</td><td>3.0000 G</td><td>1.000 M</td><td>2.9869800 G</td><td>-40.31</td><td>-27.31</td></tr> <tr><td>3.0000 G</td><td>7.0000 G</td><td>1.000 M</td><td>3.0030000 G</td><td>-38.16</td><td>-25.16</td></tr> <tr><td>7.0000 G</td><td>13.6000 G</td><td>1.000 M</td><td>10.2973900 G</td><td>-35.30</td><td>-22.30</td></tr> <tr><td>13.6000 G</td><td>19.1000 G</td><td>1.000 M</td><td>15.247938 G</td><td>-26.92</td><td>-13.92</td></tr> </tbody> </table> <p>Date: 4.SEP.2017 23:19:00</p>	Start [Hz]	Stop [Hz]	RBW [Hz]	Freq [Hz]	PwrAve [dBm]	ΔLimit [dB]	30.0000 M	1.0000 G	1.000 M	820.307500 M	-42.76	-29.76	1.0000 G	1.845 G	1.000 M	1.0669390 G	-41.81	-28.81	1.845 G	3.0000 G	1.000 M	2.9869800 G	-40.31	-27.31	3.0000 G	7.0000 G	1.000 M	3.0030000 G	-38.16	-25.16	7.0000 G	13.6000 G	1.000 M	10.2973900 G	-35.30	-22.30	13.6000 G	19.1000 G	1.000 M	15.247938 G	-26.92	-13.92	 <table border="1" data-bbox="893 1601 1292 1702"> <thead> <tr> <th>Start [Hz]</th> <th>Stop [Hz]</th> <th>RBW [Hz]</th> <th>Freq [Hz]</th> <th>PwrAve [dBm]</th> <th>ΔLimit [dB]</th> </tr> </thead> <tbody> <tr><td>30.0000 M</td><td>1.0000 G</td><td>1.000 M</td><td>171.337500 M</td><td>-31.00</td><td>-21.00</td></tr> <tr><td>1.0000 G</td><td>1.845 G</td><td>1.000 M</td><td>1.030793 G</td><td>-40.68</td><td>-27.68</td></tr> <tr><td>1.845 G</td><td>3.0000 G</td><td>1.000 M</td><td>1.933271 G</td><td>-28.62</td><td>-15.62</td></tr> <tr><td>3.0000 G</td><td>7.0000 G</td><td>1.000 M</td><td>5.146000 G</td><td>-37.86</td><td>-24.86</td></tr> <tr><td>7.0000 G</td><td>13.6000 G</td><td>1.000 M</td><td>10.245550 G</td><td>-35.37</td><td>-22.37</td></tr> <tr><td>13.6000 G</td><td>19.1000 G</td><td>1.000 M</td><td>15.434250 G</td><td>-26.39</td><td>-13.39</td></tr> </tbody> </table> <p>Date: 4.SEP.2017 23:37:39</p>	Start [Hz]	Stop [Hz]	RBW [Hz]	Freq [Hz]	PwrAve [dBm]	ΔLimit [dB]	30.0000 M	1.0000 G	1.000 M	171.337500 M	-31.00	-21.00	1.0000 G	1.845 G	1.000 M	1.030793 G	-40.68	-27.68	1.845 G	3.0000 G	1.000 M	1.933271 G	-28.62	-15.62	3.0000 G	7.0000 G	1.000 M	5.146000 G	-37.86	-24.86	7.0000 G	13.6000 G	1.000 M	10.245550 G	-35.37	-22.37	13.6000 G	19.1000 G	1.000 M	15.434250 G	-26.39	-13.39
Start [Hz]	Stop [Hz]	RBW [Hz]	Freq [Hz]	PwrAve [dBm]	ΔLimit [dB]																																																																																
30.0000 M	1.0000 G	1.000 M	820.307500 M	-42.76	-29.76																																																																																
1.0000 G	1.845 G	1.000 M	1.0669390 G	-41.81	-28.81																																																																																
1.845 G	3.0000 G	1.000 M	2.9869800 G	-40.31	-27.31																																																																																
3.0000 G	7.0000 G	1.000 M	3.0030000 G	-38.16	-25.16																																																																																
7.0000 G	13.6000 G	1.000 M	10.2973900 G	-35.30	-22.30																																																																																
13.6000 G	19.1000 G	1.000 M	15.247938 G	-26.92	-13.92																																																																																
Start [Hz]	Stop [Hz]	RBW [Hz]	Freq [Hz]	PwrAve [dBm]	ΔLimit [dB]																																																																																
30.0000 M	1.0000 G	1.000 M	171.337500 M	-31.00	-21.00																																																																																
1.0000 G	1.845 G	1.000 M	1.030793 G	-40.68	-27.68																																																																																
1.845 G	3.0000 G	1.000 M	1.933271 G	-28.62	-15.62																																																																																
3.0000 G	7.0000 G	1.000 M	5.146000 G	-37.86	-24.86																																																																																
7.0000 G	13.6000 G	1.000 M	10.245550 G	-35.37	-22.37																																																																																
13.6000 G	19.1000 G	1.000 M	15.434250 G	-26.39	-13.39																																																																																



**Frequency Stability**

Test Conditions	Middle Channel	GSM850 (GPRS class 8)	GSM850 (EDGE class 8)	Limit 2.5ppm
Temperature (°C)	Voltage (Volt)	Deviation (ppm)		Result
50	Normal Voltage	0.0024	0.0048	PASS
40	Normal Voltage	0.0048	0.0000	
30	Normal Voltage	0.0060	0.0155	
20(Ref.)	Normal Voltage	0.0000	0.0000	
10	Normal Voltage	0.0036	0.0215	
0	Normal Voltage	0.0024	0.0167	
-10	Normal Voltage	0.0024	0.0191	
-20	Normal Voltage	0.0036	0.0179	
-30	Normal Voltage	0.0036	0.0179	
20	Maximum Voltage	0.0036	0.0155	
20	Normal Voltage	0.0000	0.0000	
20	Battery End Point	0.0048	0.0000	

Test Conditions	Middle Channel	GSM1900 (GPRS class 8)	GSM1900 (EDGE class 8)	Limit Note 2.
Temperature (°C)	Voltage (Volt)	Deviation (ppm)		Result
50	Normal Voltage	0.0005	0.0037	PASS
40	Normal Voltage	0.0021	0.0005	
30	Normal Voltage	0.0011	0.0011	
20(Ref.)	Normal Voltage	0.0000	0.0000	
10	Normal Voltage	0.0032	0.0043	
0	Normal Voltage	0.0027	0.0027	
-10	Normal Voltage	0.0027	0.0021	
-20	Normal Voltage	0.0048	0.0048	
-30	Normal Voltage	0.0037	0.0021	
20	Maximum Voltage	0.0144	0.0011	
20	Normal Voltage	0.0000	0.0000	
20	Battery End Point	0.0133	0.0005	

**Note:**

1. Normal Voltage = 3.8V. ; Battery End Point (BEP) = 3.5 V. ; Maximum Voltage =4.2 V
2. The frequency fundamental emissions stay within the authorized frequency block.



## A2. WCDMA

### Peak-to-Average Ratio

Mode	WCDMA Band V	WCDMA Band II	WCDMA Band IV	Limit: 13dB
Mod.	RMC 12.2Kbps	RMC 12.2Kbps	RMC 12.2Kbps	Result
Lowest CH	2.76	2.68	2.72	<b>PASS</b>
Middle CH	2.72	2.76	2.72	
Highest CH	2.80	2.60	2.68	



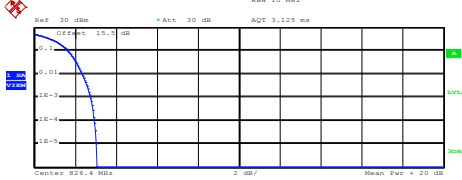
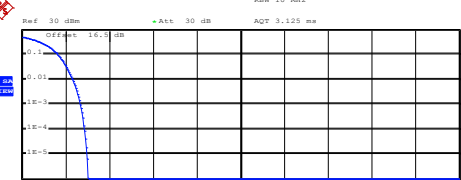
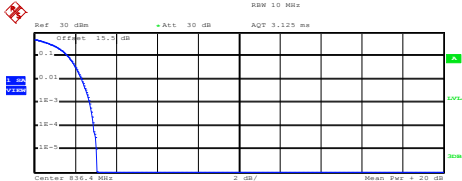
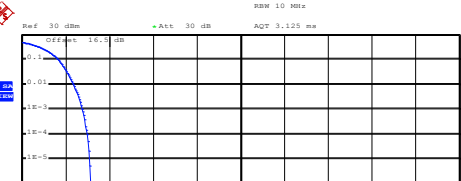
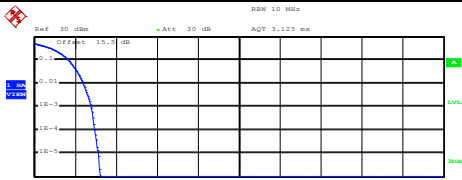
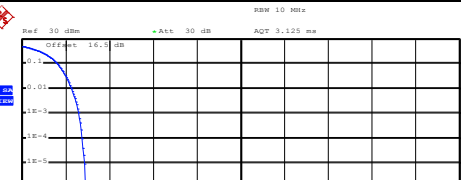

WCDMA Band V (RMC 12.2Kbps)	WCDMA Band II (RMC 12.2Kbps)																
<p align="center"><b>Lowest Channel</b></p>  <p>Center 826.4 MHz      2 dB/      Mean Pwr = 20 dB</p> <p>Complementary Cumulative Distribution Function (100000 samples)</p> <p>Trace 1</p> <p>Mean 24.66 dBm Peak 27.71 dBm Crest 3.05 dB</p> <table border="0"> <tr><td>10 %</td><td>1.64 dB</td></tr> <tr><td>1 %</td><td>2.36 dB</td></tr> <tr><td>.1 %</td><td>2.76 dB</td></tr> <tr><td>.01 %</td><td>2.96 dB</td></tr> </table> <p>Date: 5.SEP.2017 00:35:35</p>	10 %	1.64 dB	1 %	2.36 dB	.1 %	2.76 dB	.01 %	2.96 dB	<p align="center"><b>Lowest Channel</b></p>  <p>Center 1.8524 GHz      2 dB/      Mean Pwr = 20 dB</p> <p>Complementary Cumulative Distribution Function (100000 samples)</p> <p>Trace 1</p> <p>Mean 23.75 dBm Peak 26.79 dBm Crest 3.04 dB</p> <table border="0"> <tr><td>10 %</td><td>1.64 dB</td></tr> <tr><td>1 %</td><td>2.32 dB</td></tr> <tr><td>.1 %</td><td>2.68 dB</td></tr> <tr><td>.01 %</td><td>2.88 dB</td></tr> </table> <p>Date: 5.SEP.2017 00:51:32</p>	10 %	1.64 dB	1 %	2.32 dB	.1 %	2.68 dB	.01 %	2.88 dB
10 %	1.64 dB																
1 %	2.36 dB																
.1 %	2.76 dB																
.01 %	2.96 dB																
10 %	1.64 dB																
1 %	2.32 dB																
.1 %	2.68 dB																
.01 %	2.88 dB																
<p align="center"><b>Middle Channel</b></p>  <p>Center 830.4 MHz      2 dB/      Mean Pwr = 20 dB</p> <p>Complementary Cumulative Distribution Function (100000 samples)</p> <p>Trace 1</p> <p>Mean 24.59 dBm Peak 27.64 dBm Crest 3.05 dB</p> <table border="0"> <tr><td>10 %</td><td>1.64 dB</td></tr> <tr><td>1 %</td><td>2.32 dB</td></tr> <tr><td>.1 %</td><td>2.72 dB</td></tr> <tr><td>.01 %</td><td>2.92 dB</td></tr> </table> <p>Date: 5.SEP.2017 00:35:44</p>	10 %	1.64 dB	1 %	2.32 dB	.1 %	2.72 dB	.01 %	2.92 dB	<p align="center"><b>Middle Channel</b></p>  <p>Center 1.88 GHz      2 dB/      Mean Pwr = 20 dB</p> <p>Complementary Cumulative Distribution Function (100000 samples)</p> <p>Trace 1</p> <p>Mean 23.74 dBm Peak 26.86 dBm Crest 3.13 dB</p> <table border="0"> <tr><td>10 %</td><td>1.68 dB</td></tr> <tr><td>1 %</td><td>2.36 dB</td></tr> <tr><td>.1 %</td><td>2.76 dB</td></tr> <tr><td>.01 %</td><td>3.00 dB</td></tr> </table> <p>Date: 5.SEP.2017 00:51:41</p>	10 %	1.68 dB	1 %	2.36 dB	.1 %	2.76 dB	.01 %	3.00 dB
10 %	1.64 dB																
1 %	2.32 dB																
.1 %	2.72 dB																
.01 %	2.92 dB																
10 %	1.68 dB																
1 %	2.36 dB																
.1 %	2.76 dB																
.01 %	3.00 dB																
<p align="center"><b>Highest Channel</b></p>  <p>Center 846.6 MHz      2 dB/      Mean Pwr = 20 dB</p> <p>Complementary Cumulative Distribution Function (100000 samples)</p> <p>Trace 1</p> <p>Mean 24.71 dBm Peak 27.92 dBm Crest 3.21 dB</p> <table border="0"> <tr><td>10 %</td><td>1.68 dB</td></tr> <tr><td>1 %</td><td>2.40 dB</td></tr> <tr><td>.1 %</td><td>2.80 dB</td></tr> <tr><td>.01 %</td><td>2.96 dB</td></tr> </table> <p>Date: 5.SEP.2017 00:35:53</p>	10 %	1.68 dB	1 %	2.40 dB	.1 %	2.80 dB	.01 %	2.96 dB	<p align="center"><b>Highest Channel</b></p>  <p>Center 1.9376 GHz      2 dB/      Mean Pwr = 20 dB</p> <p>Complementary Cumulative Distribution Function (100000 samples)</p> <p>Trace 1</p> <p>Mean 23.67 dBm Peak 26.58 dBm Crest 2.91 dB</p> <table border="0"> <tr><td>10 %</td><td>1.64 dB</td></tr> <tr><td>1 %</td><td>2.28 dB</td></tr> <tr><td>.1 %</td><td>2.60 dB</td></tr> <tr><td>.01 %</td><td>2.76 dB</td></tr> </table> <p>Date: 5.SEP.2017 00:51:50</p>	10 %	1.64 dB	1 %	2.28 dB	.1 %	2.60 dB	.01 %	2.76 dB
10 %	1.68 dB																
1 %	2.40 dB																
.1 %	2.80 dB																
.01 %	2.96 dB																
10 %	1.64 dB																
1 %	2.28 dB																
.1 %	2.60 dB																
.01 %	2.76 dB																



WCDMA Band IV (RMC 12.2Kbps)

Lowest Channel

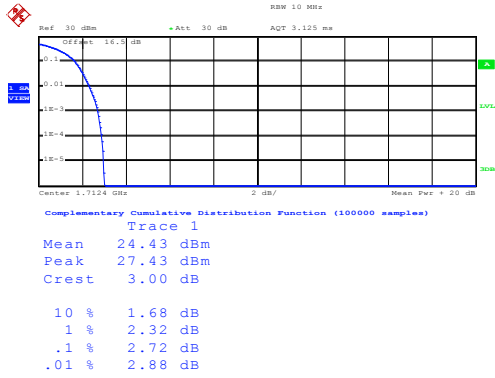

Date: 5.SEP.2017 01:37:35

Middle Channel

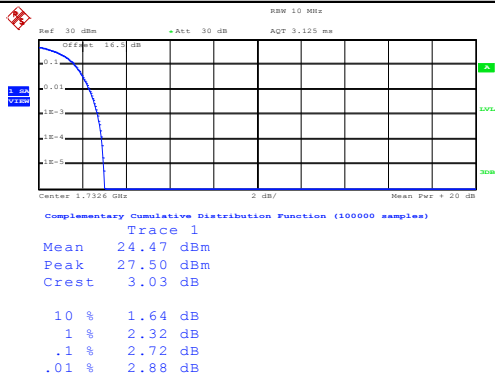

Date: 5.SEP.2017 01:37:45

Highest Channel

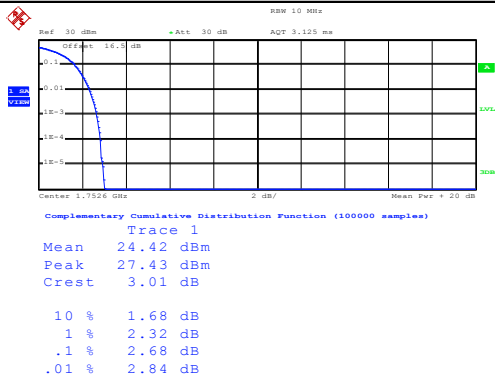

Date: 5.SEP.2017 01:37:53



**26dB Bandwidth**

Mode	WCDMA Band V 26dB BW(MHz)	WCDMA Band II 26dB BW(MHz)	WCDMA Band IV 26dB BW(MHz)
Mod.	RMC 12.2Kbps	RMC 12.2Kbps	RMC 12.2Kbps
Lowest CH	4.84	4.89	4.85
Middle CH	4.87	4.88	4.85
Highest CH	4.88	4.86	4.85



WCDMA Band V (RMC 12.2Kbps)	WCDMA Band II (RMC 12.2Kbps)
<p style="text-align: center;"><b>Lowest Channel</b></p> <p style="text-align: right;">Date: 4.SEP.2017 23:54:40</p>	<p style="text-align: center;"><b>Lowest Channel</b></p> <p style="text-align: right;">Date: 5.SEP.2017 00:38:03</p>
<p style="text-align: center;"><b>Middle Channel</b></p> <p style="text-align: right;">Date: 4.SEP.2017 23:55:08</p>	<p style="text-align: center;"><b>Middle Channel</b></p> <p style="text-align: right;">Date: 5.SEP.2017 00:38:31</p>
<p style="text-align: center;"><b>Highest Channel</b></p> <p style="text-align: right;">Date: 4.SEP.2017 23:55:36</p>	<p style="text-align: center;"><b>Highest Channel</b></p> <p style="text-align: right;">Date: 5.SEP.2017 00:38:59</p>



WCDMA Band IV (RMC 12.2Kbps)

Lowest Channel

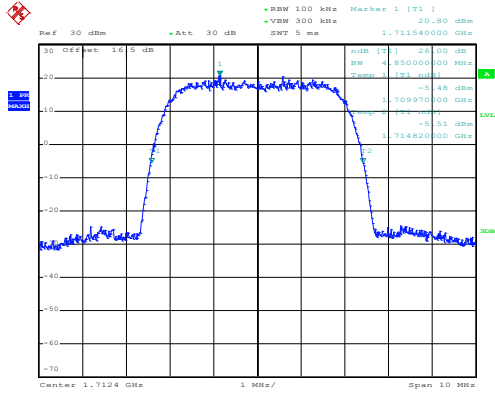

Date: 5.SEP.2017 01:35:13

Middle Channel

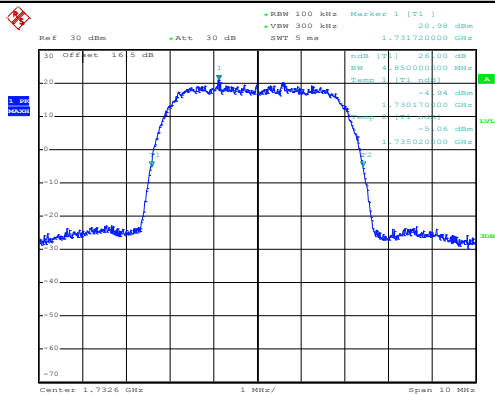

Date: 5.SEP.2017 01:35:41

Highest Channel

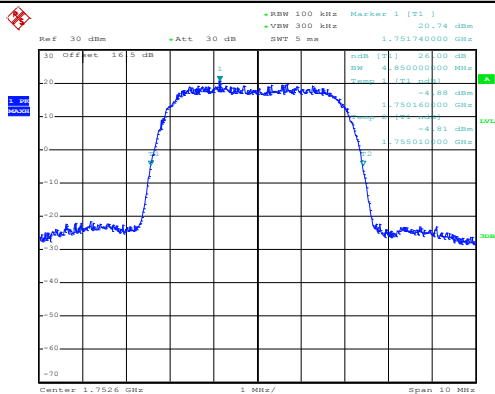

Date: 5.SEP.2017 01:36:09



**Occupied Bandwidth**

Mode	WCDMA Band V 99%OBW(MHz)	WCDMA Band II 99%OBW(MHz)	WCDMA Band IV 99%OBW(MHz)
Mod.	RMC 12.2Kbps	RMC 12.2Kbps	RMC 12.2Kbps
Lowest CH	4.22	4.21	4.22
Middle CH	4.21	4.20	4.21
Highest CH	4.21	4.22	4.22

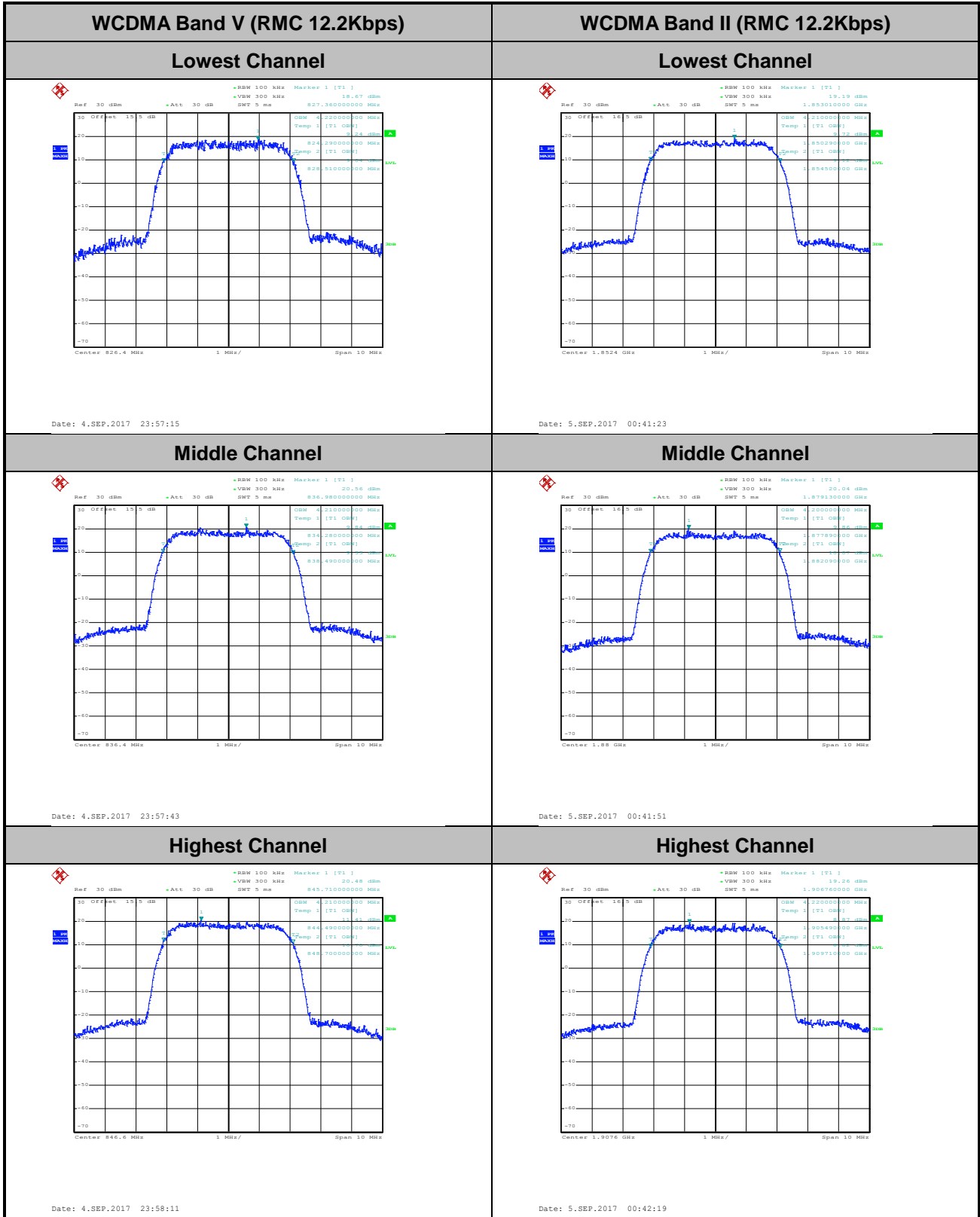



WCDMA Band IV (RMC 12.2Kbps)

Lowest Channel

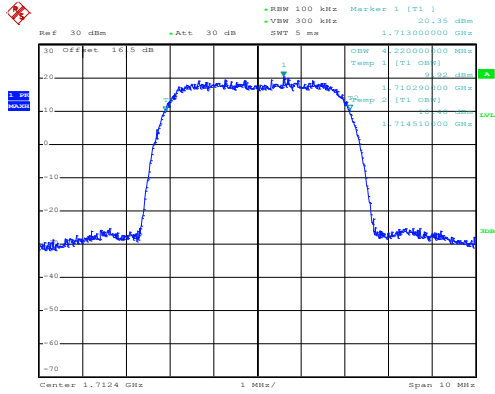

Date: 5.SEP.2017 01:33:11

Middle Channel

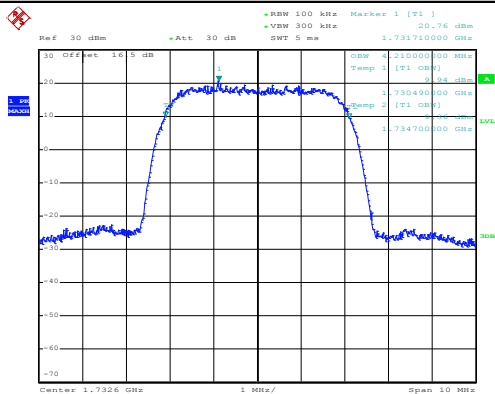

Date: 5.SEP.2017 01:33:39

Highest Channel

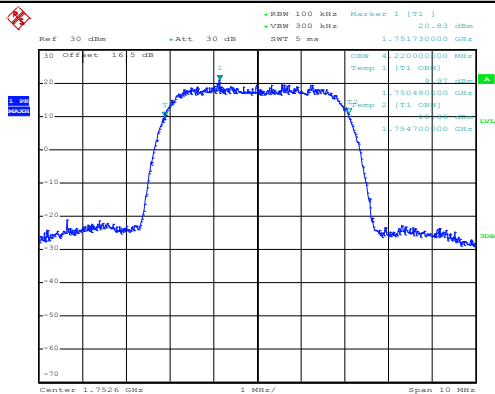

Date: 5.SEP.2017 01:34:07





**Conducted Band Edge**



WCDMA Band V (RMC 12.2Kbps)

Lowest Band Edge

Highest Band Edge

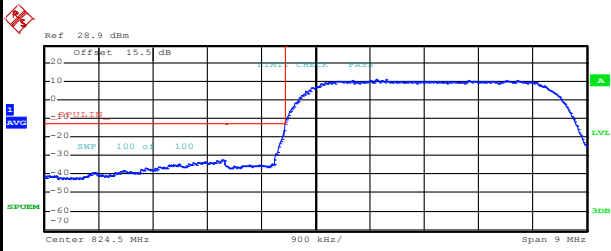

Start [Hz]	Stop [Hz]	RBW [Hz]	Freq [Hz]	PwrAbs [dBm]	ΔLimit [dB]
820.000 M	823.000 M	100.00 k	822.946000 M	-32.44	-19.44
823.000 M	824.000 M	50.00 k	823.992000 M	-16.55	-3.55
824.000 M	829.000 M	100.00 k	825.665000 M	10.80	-24.20

Date: 5.SEP.2017 00:01:02

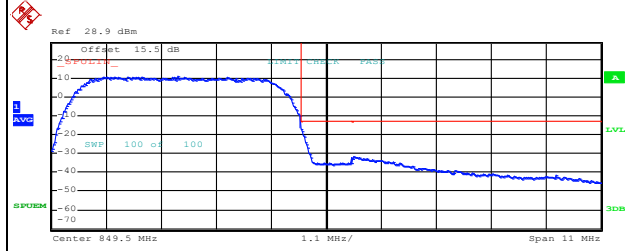

Start [Hz]	Stop [Hz]	RBW [Hz]	Freq [Hz]	PwrAbs [dBm]	ΔLimit [dB]
844.000 M	849.000 M	100.00 k	846.515000 M	11.03	-23.97
849.000 M	850.000 M	50.00 k	849.012000 M	-17.19	-4.19
850.000 M	855.000 M	100.00 k	850.045000 M	-31.85	-18.85

Date: 5.SEP.2017 00:03:44



WCDMA Band II (RMC 12.2Kbps)

Lowest Band Edge

Highest Band Edge

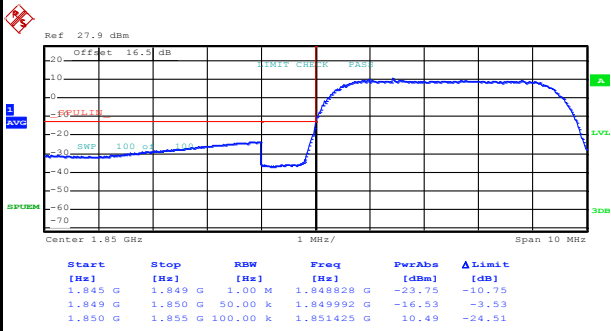

Date: 5.SEP.2017 00:47:34

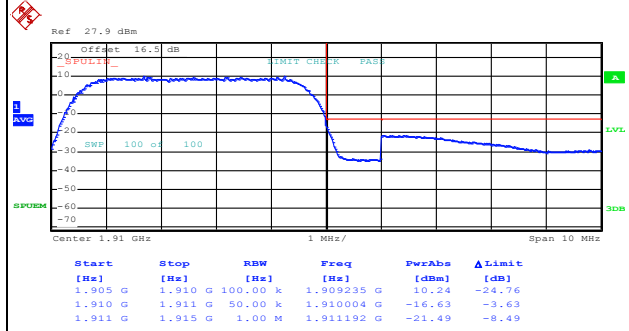

Date: 5.SEP.2017 00:50:16



WCDMA Band IV (RMC 12.2Kbps)

Lowest Band Edge

Highest Band Edge

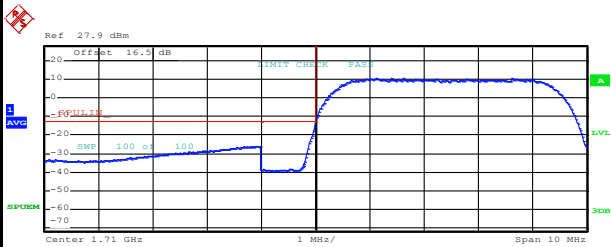

Start [Hz]	Stop [Hz]	RBW [Hz]	Freq [Hz]	PwrAbs [dBm]	ΔLimit [dB]
1.705 G	1.709 G	1.00 M	1.708908 G	-26.08	-13.08
1.709 G	1.710 G	50.00 k	1.709996 G	-15.58	-2.58
1.710 G	1.715 G	100.00 k	1.711110 G	10.92	-24.08

Date: 5.SEP.2017 01:29:05

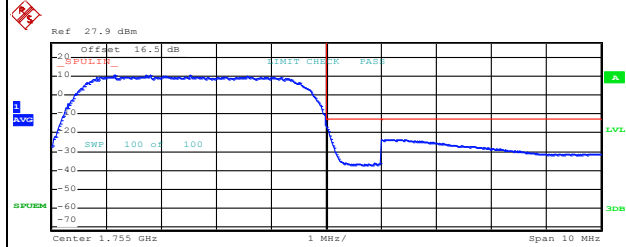

Start [Hz]	Stop [Hz]	RBW [Hz]	Freq [Hz]	PwrAbs [dBm]	ΔLimit [dB]
1.750 G	1.755 G	100.00 k	1.751330 G	10.71	-24.29
1.755 G	1.756 G	50.00 k	1.755012 G	-16.76	-3.76
1.756 G	1.760 G	1.00 M	1.756052 G	-23.57	-10.57

Date: 5.SEP.2017 01:31:47



**Conducted Spurious Emission**



WCDMA Band V (RMC 12.2Kbps)

WCDMA Band II (RMC 12.2Kbps)

Lowest Channel

Lowest Channel

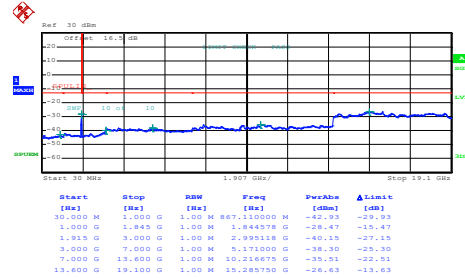
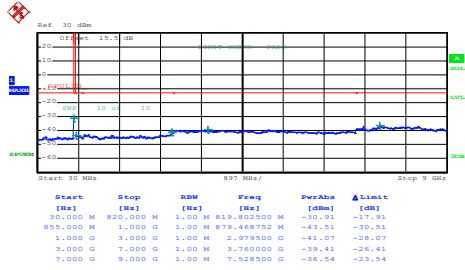

Date: 5.SEP.2017 00:33:48

Date: 5.SEP.2017 00:52:53

Middle Channel

Middle Channel

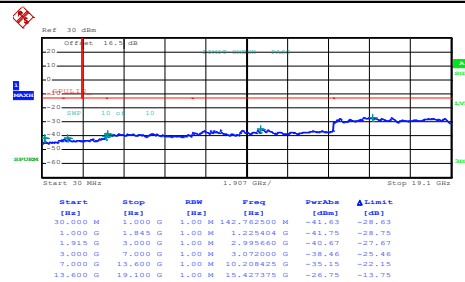
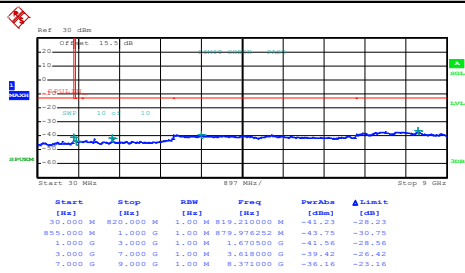

Date: 5.SEP.2017 00:34:34

Date: 5.SEP.2017 00:53:39

Highest Channel

Highest Channel

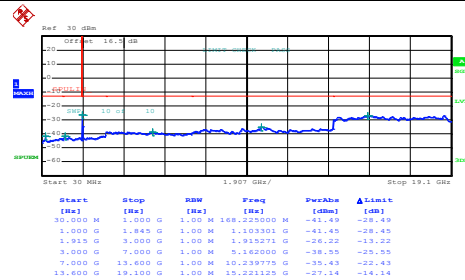
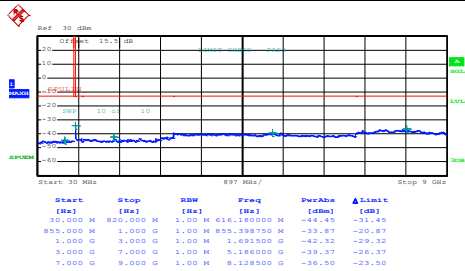

Date: 5.SEP.2017 00:35:19

Date: 5.SEP.2017 00:54:24



WCDMA Band IV (RMC 12.2Kbps)

Lowest Channel

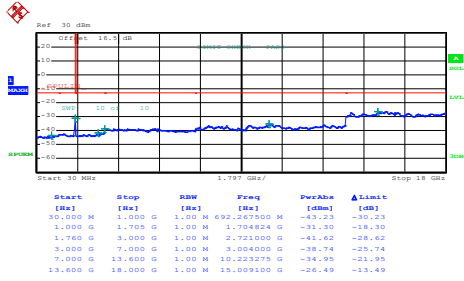

Date: 5.SEP.2017 01:24:15

Middle Channel

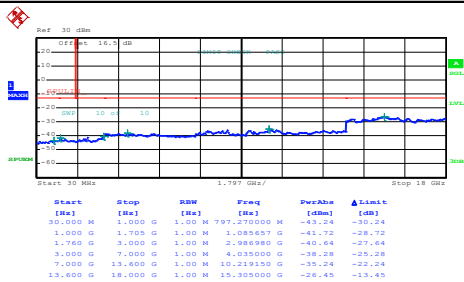

Date: 5.SEP.2017 01:25:01

Highest Channel

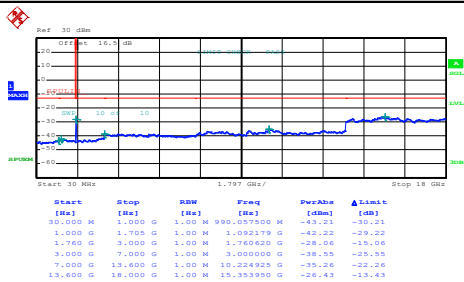

Date: 5.SEP.2017 01:25:46



**Frequency Stability**

Test Conditions	Middle Channel	WCDMA Band V (RMC 12.2Kbps)	Limit 2.5ppm
Temperature (°C)	Voltage (Volt)	Deviation (ppm)	Result
50	Normal Voltage	0.0143	PASS
40	Normal Voltage	0.0120	
30	Normal Voltage	0.0000	
20(Ref.)	Normal Voltage	0.0000	
10	Normal Voltage	0.0132	
0	Normal Voltage	0.0120	
-10	Normal Voltage	0.0000	
-20	Normal Voltage	0.0108	
-30	Normal Voltage	0.0132	
20	Maximum Voltage	0.0167	
20	Normal Voltage	0.0000	
20	Battery End Point	0.0120	

Test Conditions	Middle Channel	WCDMA Band II (RMC 12.2Kbps)	Limit Note 2.
Temperature (°C)	Voltage (Volt)	Deviation (ppm)	Result
50	Normal Voltage	0.0064	PASS
40	Normal Voltage	0.0080	
30	Normal Voltage	0.0059	
20(Ref.)	Normal Voltage	0.0000	
10	Normal Voltage	0.0074	
0	Normal Voltage	0.0064	
-10	Normal Voltage	0.0074	
-20	Normal Voltage	0.0069	
-30	Normal Voltage	0.0085	
20	Maximum Voltage	0.0080	
20	Normal Voltage	0.0000	
20	Battery End Point	0.0085	





Test Conditions	Middle Channel	WCDMA Band IV (RMC 12.2Kbps)	Limit Note 2.
Temperature (°C)	Voltage (Volt)	Deviation (ppm)	Result
50	Normal Voltage	0.0006	PASS
40	Normal Voltage	0.0006	
30	Normal Voltage	0.0006	
20(Ref.)	Normal Voltage	0.0000	
10	Normal Voltage	0.0012	
0	Normal Voltage	0.0006	
-10	Normal Voltage	0.0012	
-20	Normal Voltage	0.0012	
-30	Normal Voltage	0.0006	
20	Maximum Voltage	0.0006	
20	Normal Voltage	0.0000	
20	Battery End Point	0.0017	

**Note:**

1. Normal Voltage = 3.8V. ; Battery End Point (BEP) = 3.5 V. ; Maximum Voltage =4.2 V
2. The frequency fundamental emissions stay within the authorized frequency block.



## Appendix B. Test Results of ERP/EIRP and Radiated Test

### ERP/EIRP

Channel	Mode	Conducted		ERP	
		Power (dBm)	Power (Watts)	ERP(dBm)	ERP(W)
Lowest	GSM850	33.63	2.3067	29.18	0.8279
Middle	GPRS class 8	33.65	2.3174	29.20	0.8318
Highest	(GT - LC = -2.3 dB)	33.65	2.3174	29.20	0.8318
Lowest	GSM850	27.86	0.6109	23.41	0.2193
Middle	EDGE class 8	27.81	0.6039	23.36	0.2168
Highest	(GT - LC = -2.3 dB)	27.75	0.5957	23.30	0.2138
Lowest	WCDMA Band V	24.50	0.2818	20.05	0.1012
Middle	RMC 12.2Kbps	24.60	0.2884	20.15	0.1035
Highest	(GT - LC = -2.3 dB)	24.74	0.2979	20.29	0.1069
Limit	ERP < 7W	Result		PASS	

Channel	Mode	Conducted		EIRP	
		Power (dBm)	Power (Watts)	EIRP(dBm)	EIRP(W)
Lowest	GSM1900	30.80	1.2023	30.30	1.0715
Middle	GPRS class 8	30.78	1.1967	30.28	1.0666
Highest	(GT - LC = -0.5 dB)	30.77	1.1940	30.27	1.0641
Lowest	GSM1900	26.99	0.5000	26.49	0.4457
Middle	EDGE class 8	26.86	0.4853	26.36	0.4325
Highest	(GT - LC = -0.5 dB)	26.87	0.4864	26.37	0.4335
Lowest	WCDMA Band II	22.35	0.1718	21.85	0.1531
Middle	RMC 12.2Kbps	22.50	0.1778	22.00	0.1585
Highest	(GT - LC = -0.5 dB)	22.36	0.1722	21.86	0.1535
Limit	EIRP < 2W	Result		PASS	

Channel	Mode	Conducted		EIRP	
		Power (dBm)	Power (Watts)	EIRP(dBm)	EIRP(W)
Lowest	WCDMA Band IV	24.50	0.2818	25.10	0.3236
Middle	RMC 12.2Kbps	24.63	0.2904	25.23	0.3334
Highest	(GT - LC = 0.6 dB)	24.67	0.2931	25.27	0.3365
Limit	EIRP < 1W	Result		PASS	



**Radiated Spurious Emission**

**Part22H GPRS 850**

Mode 1_GPRS 850									
Channel	Frequency ( MHz )	ERP ( dBm )	Limit ( dBm )	Over Limit ( dB )	SPA Reading (dBm)	S.G. Power ( dBm )	TX Cable loss ( dB )	TX Antenna Gain (dBi)	Polarization (H/V)
Lowest	1648	-45.83	-13	-32.83	-33.18	-47.59	0.98	4.89	H
	2472	-45.93	-13	-32.93	-38.64	-47.81	1.28	5.32	H
	3298	-66.13	-13	-53.13	-61.01	-69.55	1.54	7.11	H
	1648	-43.93	-13	-30.93	-31.78	-45.69	0.98	4.89	V
	2472	-45.78	-13	-32.78	-38.99	-47.66	1.28	5.32	V
	3296	-66.31	-13	-53.31	-61.5	-69.72	1.54	7.10	V
Middle	1672	-49.01	-13	-36.01	-36.7	-50.69	0.99	4.82	H
	2512	-44.84	-13	-31.84	-37.7	-46.81	1.29	5.41	H
	3345	-66.08	-13	-53.08	-61.17	-69.69	1.56	7.32	H
	4184	-59.03	-13	-46.03	-54.72	-63.65	1.87	8.64	H
	1672	-47.98	-13	-34.98	-36.13	-49.66	0.99	4.82	V
	2512	-43.36	-13	-30.36	-36.74	-45.33	1.29	5.41	V
	3345	-65.44	-13	-52.44	-60.69	-69.05	1.56	7.32	V
	4184	-61.39	-13	-48.39	-56.95	-66.01	1.87	8.64	V
Highest	1696	-52.42	-13	-39.42	-40.12	-54.02	1.00	4.75	H
	2544	-50.91	-13	-37.91	-43.84	-52.89	1.30	5.44	H
	3393	-65.74	-13	-52.74	-61.02	-69.55	1.57	7.53	H
	4248	-55.88	-13	-42.88	-51.77	-60.48	1.90	8.65	H
	1696	-51.17	-13	-38.17	-39.35	-52.77	1.00	4.75	V
	2544	-48.24	-13	-35.24	-41.71	-50.22	1.30	5.44	V
	3393	-65.58	-13	-52.58	-61.04	-69.39	1.57	7.53	V
	4248	-58.28	-13	-45.28	-54.18	-62.88	1.90	8.65	V

Remark: Spurious emissions within 30-1000MHz were found more than 20dB below limit line.



**Part22H EDGE 850**

Mode 2_EDGE 850									
Channel	Frequency ( MHz )	ERP ( dBm )	Limit ( dBm )	Over Limit ( dB )	SPA Reading (dBm)	S.G. Power ( dBm )	TX Cable loss ( dB )	TX Antenna Gain (dBi)	Polarization (H/V)
Lowest	1648	-48.29	-13	-35.29	-35.48	-50.05	0.98	4.89	H
	2472	-56.23	-13	-43.23	-48.77	-58.11	1.28	5.32	H
	3296	-66.70	-13	-53.70	-61.45	-70.11	1.54	7.10	H
	4120	-62.58	-13	-49.58	-57.84	-67.22	1.83	8.62	H
									H
									H
									H
	1648	-45.77	-13	-32.77	-33.45	-47.53	0.98	4.89	V
	2472	-51.46	-13	-38.46	-44.51	-53.34	1.28	5.32	V
	3296	-65.84	-13	-52.84	-61	-69.25	1.54	7.10	V
	4120	-63.58	-13	-50.58	-59.02	-68.22	1.83	8.62	V
									V
									V
									V
Middle	1672	-51.88	-13	-38.88	-39.31	-53.56	0.99	4.82	H
	2512	-57.67	-13	-44.67	-50.4	-59.64	1.29	5.41	H
	3344	-66.37	-13	-53.37	-61.35	-69.98	1.56	7.31	H
									H
									H
									H
	1672	-51.37	-13	-38.37	-39.34	-53.05	0.99	4.82	V
	2512	-55.47	-13	-42.47	-48.65	-57.44	1.29	5.41	V
	3344	-65.86	-13	-52.86	-61.04	-69.47	1.56	7.31	V
									V
									V
									V
									V
									V



Highest	1696	-64.06	-13	-51.06	-51.73	-65.66	1.00	4.75	H
	2544	-66.44	-13	-53.44	-59.28	-68.42	1.30	5.44	H
	3392	-66.03	-13	-53.03	-61.29	-69.83	1.57	7.52	H
									H
									H
									H
	1696	-63.17	-13	-50.17	-51.22	-64.77	1.00	4.75	V
	2544	-64.27	-13	-51.27	-57.56	-66.25	1.30	5.44	V
	3392	-65.94	-13	-52.94	-61.25	-69.74	1.57	7.52	V
									V
									V
									V
									V
									V

Remark: Spurious emissions within 30-1000MHz were found more than 20dB below limit line.



**Part22H WCDMA 850**

Mode 3_WCDMA 850									
Channel	Frequency ( MHz )	ERP ( dBm )	Limit ( dBm )	Over Limit ( dB )	SPA Reading (dBm)	S.G. Power ( dBm )	TX Cable loss ( dB )	TX Antenna Gain (dBi)	Polarization (H/V)
Lowest	1648	-58.47	-13	-45.47	-45.62	-60.23	0.98	4.89	H
	2480	-63.77	-13	-50.77	-56.38	-65.68	1.28	5.34	H
	3312	-63.88	-13	-50.88	-58.78	-67.36	1.55	7.17	H
									H
									H
									H
	1648	-58.97	-13	-45.97	-46.65	-60.73	0.98	4.89	V
	2480	-61.42	-13	-48.42	-54.48	-63.33	1.28	5.34	V
	3312	-62.94	-13	-49.94	-58.09	-66.42	1.55	7.17	V
									V
									V
									V
									V
									V
Middle	1672	-60.54	-13	-47.54	-48.02	-62.22	0.99	4.82	H
	2504	-65.56	-13	-52.56	-58.23	-67.52	1.29	5.40	H
	3344	-61.47	-13	-48.47	-56.5	-65.08	1.56	7.31	H
									H
									H
									H
	1672	-59.78	-13	-46.78	-47.74	-61.46	0.99	4.82	V
	2504	-62.30	-13	-49.30	-55.4	-64.26	1.29	5.40	V
	3344	-59.36	-13	-46.36	-54.61	-62.97	1.56	7.31	V
									V
									V
									V
									V
									V
								V	



Highest	1696	-60.86	-13	-47.86	-48.52	-62.46	1.00	4.75	H
	2536	-62.98	-13	-49.98	-55.76	-64.96	1.30	5.43	H
	3384	-54.44	-13	-41.44	-49.57	-58.21	1.57	7.49	H
									H
									H
									H
	1696	-59.48	-13	-46.48	-47.57	-61.08	1.00	4.75	V
	2536	-60.98	-13	-47.98	-54.27	-62.96	1.30	5.43	V
	3384	-53.72	-13	-40.72	-48.97	-57.49	1.57	7.49	V
									V
									V
									V
									V
									V

Remark: Spurious emissions within 30-1000MHz were found more than 20dB below limit line.



**Part24E GPRS 1900**

Mode 1_GPRS 1900									
Channel	Frequency ( MHz )	EIRP ( dBm )	Limit ( dBm )	Over Limit ( dB )	SPA Reading (dBm)	S.G. Power ( dBm )	TX Cable loss ( dB )	TX Antenna Gain (dBi)	Polarization (H/V)
Lowest	3702	-65.46	-13	-52.46	-60.66	-72.03	1.67	8.24	H
	5550	-60.02	-13	-47.02	-62.59	-67.09	2.65	9.72	H
	7400	-61.54	-13	-48.54	-65.41	-70.68	2.46	11.60	H
									H
									H
									H
	3702	-65.38	-13	-52.38	-60.64	-71.96	1.67	8.24	V
	5550	-60.27	-13	-47.27	-62.78	-67.33	2.66	9.72	V
	7400	-61.32	-13	-48.32	-65.31	-70.48	2.46	11.62	V
									V
									V
									V
									V
									V
Middle	3762	-64.16	-13	-51.16	-59.28	-70.79	1.69	8.31	H
	5640	-60.77	-13	-47.77	-63.68	-67.82	2.71	9.76	H
	7520	-61.64	-13	-48.64	-65.59	-71.03	2.42	11.81	H
									H
									H
									H
	3762	-64.24	-13	-51.24	-59.42	-70.87	1.69	8.31	V
	5640	-59.86	-13	-46.86	-62.73	-66.91	2.71	9.76	V
	7520	-61.23	-13	-48.23	-65.43	-70.62	2.42	11.81	V
									V
									V
									V
									V
									V
								V	





Highest	3822	-63.34	-13	-50.34	-58.38	-70.02	1.71	8.39	H
	5730	-60.72	-13	-47.72	-63.96	-67.75	2.76	9.79	H
	7638	-60.16	-13	-47.16	-64.49	-69.66	2.38	11.88	H
									H
									H
									H
	3822	-62.06	-13	-49.06	-57.18	-68.74	1.71	8.39	V
	5730	-60.22	-13	-47.22	-63.52	-67.25	2.76	9.79	V
	7638	-59.24	-13	-46.24	-63.84	-68.74	2.38	11.88	V
									V
									V
									V
									V
									V

Remark: Spurious emissions within 30-1000MHz were found more than 20dB below limit line.



**Part24E EDGE 1900**

Mode 2_EDGE 1900									
Channel	Frequency ( MHz )	EIRP ( dBm )	Limit ( dBm )	Over Limit ( dB )	SPA Reading (dBm)	S.G. Power ( dBm )	TX Cable loss ( dB )	TX Antenna Gain (dBi)	Polarization (H/V)
Lowest	3702	-59.64	-13	-46.64	-55.08	-66.21	1.67	8.24	H
	5550	-53.98	-13	-40.98	-56.6	-61.05	2.65	9.72	H
	7404	-59.88	-13	-46.88	-63.81	-69.03	2.46	11.61	H
									H
									H
									H
	3702	-59.02	-13	-46.02	-54.44	-65.59	1.67	8.24	V
	5550	-50.94	-13	-37.94	-53.45	-58.01	2.65	9.72	V
	7404	-60.18	-13	-47.18	-64.32	-69.33	2.46	11.61	V
									V
									V
									V
									V
									V
Middle	3762	-59.39	-13	-46.39	-54.73	-66.02	1.69	8.31	H
	5640	-45.07	-13	-32.07	-48.12	-52.12	2.71	9.76	H
	7518	-59.94	-13	-46.94	-64.06	-69.33	2.42	11.81	H
									H
									H
									H
	3762	-58.48	-13	-45.48	-53.79	-65.11	1.69	8.31	V
	5640	-53.97	-13	-40.97	-56.77	-61.02	2.71	9.76	V
	7518	-60.67	-13	-47.67	-64.83	-70.06	2.42	11.81	V
									V
									V
									V
									V
									V
								V	



Highest	3822	-56.34	-13	-43.34	-51.33	-63.02	1.71	8.39	H
	5730	-50.85	-13	-37.85	-54.23	-57.88	2.76	9.79	H
	7638	-59.71	-13	-46.71	-64.12	-69.21	2.38	11.88	H
									H
									H
									H
	3822	-58.33	-13	-45.33	-53.49	-65.01	1.71	8.39	V
	5730	-52.19	-13	-39.19	-55.65	-59.22	2.76	9.79	V
	7638	-59.52	-13	-46.52	-64.09	-69.02	2.38	11.88	V
									V
									V
									V
									V
									V

Remark: Spurious emissions within 30-1000MHz were found more than 20dB below limit line.



**Part24E WCDMA 1900**

Mode 3_WCDMA 1900									
Channel	Frequency ( MHz )	EIRP ( dBm )	Limit ( dBm )	Over Limit ( dB )	SPA Reading (dBm)	S.G. Power ( dBm )	TX Cable loss ( dB )	TX Antenna Gain (dBi)	Polarization (H/V)
Lowest	3702	-54.02	-13	-41.02	-49.36	-60.59	1.67	8.24	H
	5556	-57.94	-13	-44.94	-60.41	-65.01	2.66	9.72	H
	7404	-61.51	-13	-48.51	-65.56	-70.66	2.46	11.61	H
									H
									H
									H
	3702	-58.65	-13	-45.65	-54.05	-65.22	1.67	8.24	V
	5562	-59.16	-13	-46.16	-61.78	-66.22	2.66	9.72	V
	7404	-61.29	-13	-48.29	-65.48	-70.44	2.46	11.61	V
									V
									V
									V
									V
									V
Middle	3756	-54.57	-13	-41.57	-49.76	-61.19	1.68	8.31	H
	5640	-58.31	-13	-45.31	-61.39	-65.36	2.71	9.76	H
	7520	-61.27	-13	-48.27	-65.48	-70.66	2.42	11.81	H
									H
									H
									H
	3756	-60.93	-13	-47.93	-56.22	-67.55	1.68	8.31	V
	5640	-59.96	-13	-46.96	-62.93	-67.01	2.71	9.76	V
	7520	-61.49	-13	-48.49	-65.89	-70.88	2.42	11.81	V
									V
									V
									V
									V
									V
								V	



Highest	3816	-51.91	-13	-38.91	-47	-58.59	1.70	8.38	H
	5718	-58.08	-13	-45.08	-61.57	-65.12	2.75	9.79	H
	7650	-59.51	-13	-46.51	-63.96	-69.02	2.38	11.89	H
									H
									H
									H
	3816	-60.33	-13	-47.33	-55.39	-67.01	1.70	8.38	V
	5718	-59.18	-13	-46.18	-62.59	-66.22	2.75	9.79	V
	7650	-59.91	-13	-46.91	-64.8	-69.42	2.38	11.89	V
									V
									V
									V
									V
									V

Remark: Spurious emissions within 30-1000MHz were found more than 20dB below limit line.



**Part27L WCDMA 1700**

Mode 1_WCDMA 1700									
Channel	Frequency ( MHz )	EIRP ( dBm )	Limit ( dBm )	Over Limit ( dB )	SPA Reading (dBm)	S.G. Power ( dBm )	TX Cable loss ( dB )	TX Antenna Gain (dBi)	Polarization (H/V)
Lowest	3426	-52.72	-13	-39.72	-48.05	-58.81	1.58	7.67	H
	5136	-52.78	-13	-39.78	-52.82	-60.06	2.42	9.70	H
	6846	-60.94	-13	-47.94	-65.21	-68.92	2.64	10.62	H
									H
									H
									H
	3426	-58.96	-13	-45.96	-54.33	-65.05	1.58	7.67	V
	5136	-57.04	-13	-44.04	-56.94	-64.32	2.42	9.70	V
	6846	-60.67	-13	-47.67	-64.84	-68.65	2.64	10.62	V
									V
									V
									V
									V
									V
Middle	3468	-52.69	-13	-39.69	-48.1	-58.95	1.59	7.86	H
	5196	-51.74	-13	-38.74	-52.19	-58.99	2.45	9.70	H
	6930	-61.36	-13	-48.36	-65.42	-69.46	2.61	10.72	H
									H
									H
									H
	3468	-59.68	-13	-46.68	-55.03	-65.94	1.59	7.86	V
	5196	-58.77	-13	-45.77	-59.08	-66.02	2.45	9.70	V
	6930	-61.46	-13	-48.46	-65.53	-69.56	2.61	10.72	V
									V
									V
									V
									V
									V



Highest	3510	-51.23	-13	-38.23	-46.8	-57.63	1.61	8.01	H
	5256	-51.17	-13	-38.17	-51.92	-58.39	2.48	9.70	H
	7010	-60.38	-13	-47.38	-64.33	-68.61	2.59	10.82	H
									H
									H
									H
	3510	-58.88	-13	-45.88	-54.34	-65.28	1.61	8.01	V
	5256	-55.96	-13	-42.96	-56.65	-63.18	2.48	9.70	V
	7010	-60.44	-13	-47.44	-64.46	-68.67	2.59	10.82	V
									V
									V
									V
									V
									V

Remark: Spurious emissions within 30-1000MHz were found more than 20dB below limit line.