



CERTIFICATION TEST REPORT

Report Number. : 12380932-E4V1

Applicant : SONY MOBILE COMMUNICATIONS, INC.
4-12-3 HIGASHI-SHINAGAWA
SHINAGAWA-KU, TOKYO, 140-0002, JAPAN

FCC ID : PY7-12644J

EUT Description : GSM/WCDMA/LTE Phone with BT, DTS/UNII a/b/g/n/ac & NFC

Test Standard(s) : FCC 47 CFR PART 15 SUBPART C

Date Of Issue:

July 20, 2018

Prepared by:

UL Verification Services Inc.
47173 Benicia Street
Fremont, CA 94538 U.S.A.
TEL: (510) 771-1000
FAX: (510) 661-0888



NVLAP Lab code: 200065-0

REPORT REVISION HISTORY

Rev.	Issue Date	Revisions	Revised By
V1	7/20/2018	Initial Issue	

TABLE OF CONTENTS

REPORT REVISION HISTORY	2
TABLE OF CONTENTS	3
1. ATTESTATION OF TEST RESULTS	5
2. TEST METHODOLOGY	6
3. FACILITIES AND ACCREDITATION	6
4. CALIBRATION AND UNCERTAINTY	7
4.1. <i>MEASURING INSTRUMENT CALIBRATION</i>	<i>7</i>
4.2. <i>SAMPLE CALCULATION</i>	<i>7</i>
4.3. <i>MEASUREMENT UNCERTAINTY.....</i>	<i>7</i>
5. EQUIPMENT UNDER TEST.....	8
5.1. <i>EUT DESCRIPTION.....</i>	<i>8</i>
5.2. <i>MAXIMUM OUTPUT POWER.....</i>	<i>8</i>
5.3. <i>DESCRIPTION OF AVAILABLE ANTENNAS.....</i>	<i>8</i>
5.4. <i>SOFTWARE AND FIRMWARE.....</i>	<i>8</i>
5.5. <i>WORST-CASE CONFIGURATION AND MODE.....</i>	<i>9</i>
5.6. <i>DESCRIPTION OF TEST SETUP.....</i>	<i>10</i>
6. MEASUREMENT METHOD.....	13
7. TEST AND MEASUREMENT EQUIPMENT	14
8. ANTENNA PORT TEST RESULTS	15
8.1. <i>ON TIME AND DUTY CYCLE.....</i>	<i>15</i>
8.2. <i>99% BANDWIDTH.....</i>	<i>17</i>
8.2.1. <i>802.11b MODE</i>	<i>18</i>
8.2.2. <i>802.11g MODE</i>	<i>21</i>
8.2.3. <i>802.11n HT20 MODE</i>	<i>24</i>
8.3. <i>6 dB BANDWIDTH.....</i>	<i>27</i>
8.3.1. <i>802.11b MODE</i>	<i>28</i>
8.3.2. <i>802.11g MODE</i>	<i>31</i>
8.3.3. <i>802.11n HT20 MODE</i>	<i>34</i>
8.4. <i>OUTPUT POWER.....</i>	<i>37</i>
8.4.1. <i>802.11b MODE</i>	<i>38</i>
8.4.2. <i>802.11g MODE</i>	<i>39</i>
8.4.3. <i>802.11n HT20 MODE</i>	<i>40</i>
8.5. <i>POWER SPECTRAL DENSITY.....</i>	<i>41</i>
8.5.1. <i>802.11b MODE</i>	<i>42</i>
8.5.2. <i>802.11g MODE</i>	<i>45</i>
8.5.3. <i>802.11n HT20 MODE</i>	<i>48</i>

8.6.	CONDUCTED SPURIOUS EMISSIONS.....	51
8.6.1.	802.11b MODE	52
8.6.2.	802.11g MODE	56
8.6.3.	802.11n HT20 MODE	60
9.	RADIATED TEST RESULTS.....	64
9.1.	TRANSMITTER ABOVE 1 GHz.....	65
9.1.1.	TX ABOVE 1 GHz 802.11b MODE IN THE 2.4 GHz BAND	65
9.1.2.	TX ABOVE 1 GHz 802.11g MODE IN THE 2.4 GHz BAND	79
9.1.3.	TX ABOVE 1 GHz 802.11n HT20 MODE IN THE 2.4 GHz BAND.....	95
9.2.	Worst Case Below 30 MHz	111
9.3.	Worst Case Below 1 GHz	112
9.4.	Worst Case 18-26 GHz.....	114
10.	AC POWER LINE CONDUCTED EMISSIONS	116
10.1.1.	AC Power Line Norm	117
11.	SETUP PHOTOS.....	119

1. ATTESTATION OF TEST RESULTS

COMPANY NAME: SONY MOBILE COMMUNICATIONS, INC.
4-12-3 HIGASHI-SHINAGAWA,
SHINAGAWA-KU, TOKYO, 140-0002, JAPAN

EUT DESCRIPTION: GSM/WCDMA/LTE Phone with BT, DTS/UNII a/b/g/n/ac & NFC

SERIAL NUMBER: BH93004ADB, BH93000ADB (Conducted),
BH930027D8, BH93004RD8, BH93004ND8 (Radiated)

DATE TESTED: JULY 7 – 18, 2018

APPLICABLE STANDARDS	
STANDARD	TEST RESULTS
CFR 47 Part 15 Subpart C	Complies

UL Verification Services Inc. tested the above equipment in accordance with the requirements set forth in the above standards. All indications of Pass/Fail in this report are opinions expressed by UL Verification Services Inc. based on interpretations and/or observations of test results. Measurement Uncertainties were not taken into account and are published for informational purposes only. The test results show that the equipment tested is capable of demonstrating compliance with the requirements as documented in this report.

Note: The results documented in this report apply only to the tested sample, under the conditions and modes of operation as described herein. This document may not be altered or revised in any way unless done so by UL Verification Services Inc. and all revisions are duly noted in the revisions section. Any alteration of this document not carried out by UL Verification Services Inc. will constitute fraud and shall nullify the document. This report must not be used by the client to claim product certification, approval, or endorsement by NVLAP, NIST, any agency of the Federal Government, or any agency of the U.S. government.

Approved & Released For
UL Verification Services Inc. By:

Reviewed By:



Dan Corona
CONSUMER TECHNOLOGY DIVISION
Operations Leader
UL Verification Services Inc.

Kiya Kedida
CONSUMER TECHNOLOGY DIVISION
Project Engineer
UL Verification Services Inc.

2. TEST METHODOLOGY

The tests documented in this report were performed in accordance with FCC CFR 47 Part 2, FCC CFR 47 Part 15, KDB 558074 D01 v4, and ANSI C63.10-2013.

3. FACILITIES AND ACCREDITATION

The test sites and measurement facilities used to collect data are located at 47173 and 47266 Benicia Street, and 47658 Kato Road, Fremont, California, USA. Line conducted emissions are measured only at the 47173 address. The following table identifies which facilities were utilized for radiated emission measurements documented in this report. Specific facilities are also identified in the test results sections.

47173 Benicia Street	47266 Benicia Street	47658 Kato Rd.
<input checked="" type="checkbox"/> Chamber A (ISED:2324B-1)	<input type="checkbox"/> Chamber D (ISED:22541-1)	<input type="checkbox"/> Chamber K (ISED: 2324A-1)
<input type="checkbox"/> Chamber B (ISED:2324B-2)	<input type="checkbox"/> Chamber E (ISED:22541-2)	<input type="checkbox"/> Chamber L (ISED: 2324A-3)
<input type="checkbox"/> Chamber C (ISED:2324B-3)	<input type="checkbox"/> Chamber F (ISED:22541-3)	
	<input type="checkbox"/> Chamber G (ISED:22541-4)	
	<input type="checkbox"/> Chamber H (ISED:22541-5)	

The above test sites and facilities are covered under FCC Test Firm Registration # 208313. Chambers A through C are covered under ISED company address code 2324B with site numbers 2324B -1 through 2324B-3, respectively. Chambers D through H are covered under ISED company address code 22541 with site numbers 22541 -1 through 22541-5, respectively. Chambers K and L are covered under ISED company address code 2324A with site numbers 2324A-1 and 2324A-3, respectively.

UL Verification Services Inc. is accredited by NVLAP, Laboratory Code 200065-0

4. CALIBRATION AND UNCERTAINTY

4.1. MEASURING INSTRUMENT CALIBRATION

The measuring equipment utilized to perform the tests documented in this report has been calibrated in accordance with the manufacturer's recommendations, and is traceable to recognized national standards.

4.2. SAMPLE CALCULATION

Where relevant, the following sample calculation is provided:

$$\begin{aligned} \text{Field Strength (dBuV/m)} &= \text{Measured Voltage (dBuV)} + \text{Antenna Factor (dB/m)} + \\ &\text{Cable Loss (dB)} - \text{Preamp Gain (dB)} \\ 36.5 \text{ dBuV} + 18.7 \text{ dB/m} + 0.6 \text{ dB} - 26.9 \text{ dB} &= 28.9 \text{ dBuV/m} \end{aligned}$$

4.3. MEASUREMENT UNCERTAINTY

Where relevant, the following measurement uncertainty levels have been estimated for tests performed on the apparatus:

PARAMETER	UNCERTAINTY
Worst Case Conducted Disturbance, 9KHz to 0.15 MHz	3.84 dB
Worst Case Conducted Disturbance, 0.15 to 30 MHz	3.65 dB
Worst Case Radiated Disturbance, 9KHz to 30 MHz	3.15 dB
Worst Case Radiated Disturbance, 30 to 1000 MHz	5.36 dB
Worst Case Radiated Disturbance, 1000 to 18000 MHz	4.32 dB
Worst Case Radiated Disturbance, 18000 to 26000 MHz	4.45 dB
Worst Case Radiated Disturbance, 26000 to 40000 MHz	5.24 dB

Uncertainty figures are valid to a confidence level of 95%.

5. EQUIPMENT UNDER TEST

5.1. EUT DESCRIPTION

The EUT is a GSM/WCDMA/LTE Phone with BT, DTS/UNII a/b/g/n/ac & NFC.

5.2. MAXIMUM OUTPUT POWER

The transmitter has a maximum conducted output power as follows:

2.4GHz BAND

Frequency Range (MHz)	Mode	Output Power (dBm)	Output Power (mW)
2Tx			
2412 - 2472	802.11b CDD	18.28	67.30
2412 - 2472	802.11g CDD	18.46	70.15
2412 - 2472	802.11n HT20 CDD	18.32	67.92

5.3. DESCRIPTION OF AVAILABLE ANTENNAS

The radio utilizes Loop Antennas with maximum gain as below table:

Frequency Band (GHz)	Chain 0	Chain 1
	Antenna Gain (dBi)	Antenna Gain (dBi)
2.4	-1.50	-10.40

5.4. SOFTWARE AND FIRMWARE

The firmware installed in the EUT during testing was s_atp_0_00436_A_12_16.
 The test utility software used during testing was Tera Term Ver 4.79

5.5. WORST-CASE CONFIGURATION AND MODE

Radiated emissions below 1GHz, above 18GHz, and power line conducted emission were performed with the EUT set to transmit at the channel with highest output power as worst-case scenario.

Band edge and radiated emissions between 1GHz and 18GHz were performed with the EUT set to transmit at the highest power on low, middle and high channels.

The fundamental of the EUT was investigated in three orthogonal orientations X,Y,Z, it was determined that Y orientation was worst-case orientation; therefore, all final radiated testing was performed with the EUT in Y orientation.

Worst-case data rates as provided by the client were:

802.11b mode: 1 Mbps
802.11g mode: 6 Mbps
802.11n HT20mode: MCS0

The simultaneous mode (SISO 2.4GHz Chain 0 and 5GHz chain 1) was checked and stand-alone (MIMO) 2.4 GHz / 5GHz remain the worst case.

NOTE: SISO mode is covered by MIMO mode due to same maximum tune-up limit (power).

5.6. DESCRIPTION OF TEST SETUP

SUPPORT EQUIPMENT

Support Equipment List				
Description	Manufacturer	Model	Serial Number	FCC ID
Laptop	Lenovo	20B7S0A200	PC015REW	N/A
Desktop	Lenovo	ThinkCentre	MJ00QA59	N/A
AC Adapter	SONY	UCH20	3416W45305784	N/A
DC Power Supply	Ametek	XT 15-4	T463	N/A

I/O CABLES (CONDUCTED TEST)

I/O Cable List						
Cable No	Port	# of identical ports	Connector Type	Cable Type	Cable Length (m)	Remarks
1	Antenna	1	RF	Shielded	0.2	To spectrum Analyzer
2	USB	1	USB Type C	Shielded	1	N/A
3	DC	1	DC	Shielded	0.3	N/A

I/O CABLES (RADIATED AND CONDUCTED EMISSIONS)

I/O Cable List						
Cable No	Port	# of identical ports	Connector Type	Cable Type	Cable Length (m)	Remarks
1	USB	1	USB Type C	Shielded	3	N/A

CONDCUTED TEST SETUP DIAGRAM

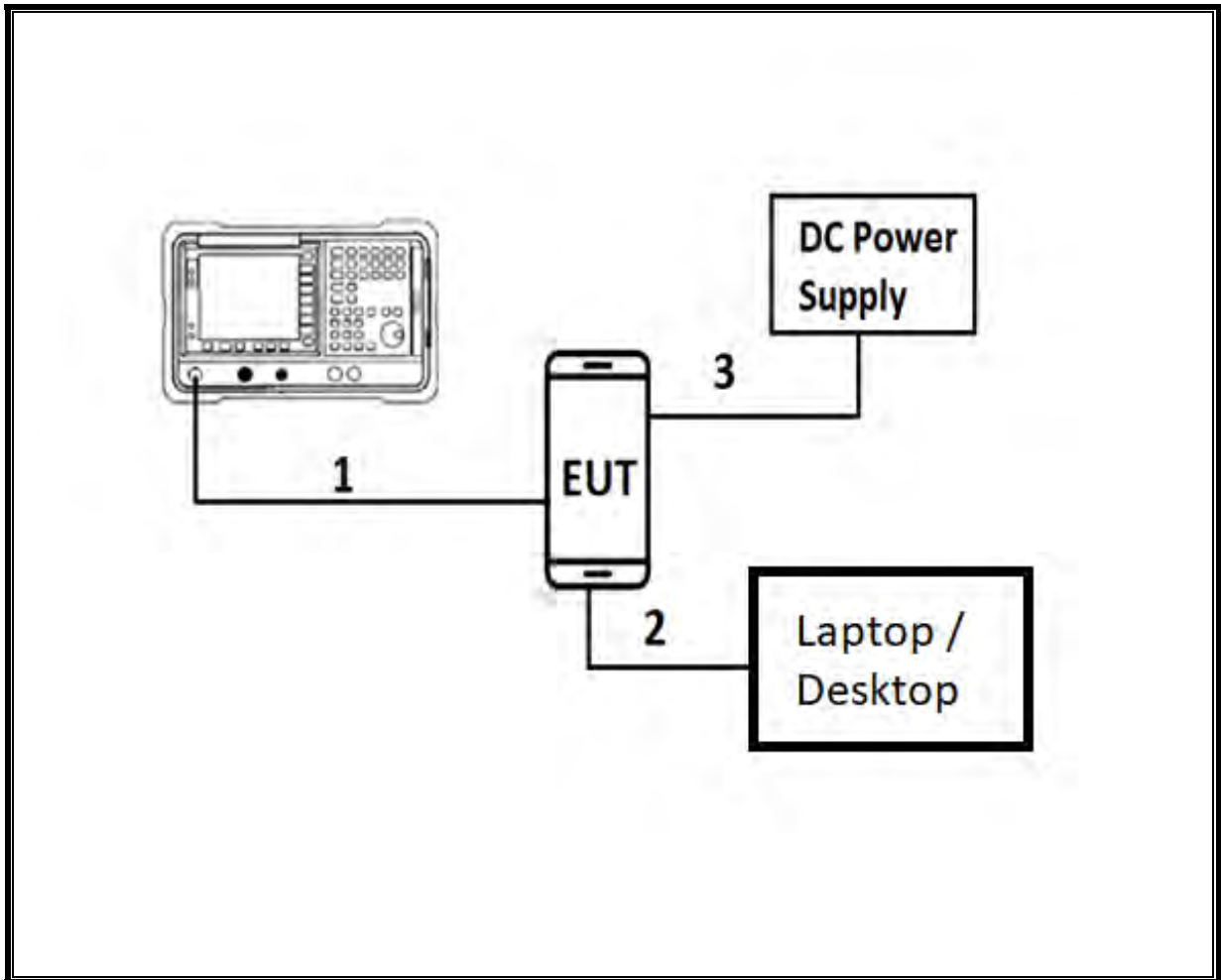

TEST SETUP

For conducted tests: the EUT was connected to a host laptop via an USB cable for parameter setting purpose such as channel, output power...etc. The test software exercises the radio.

RADIATED AND AC LINE CONDUCTED EMISSIONS SETUP DIAGRAM

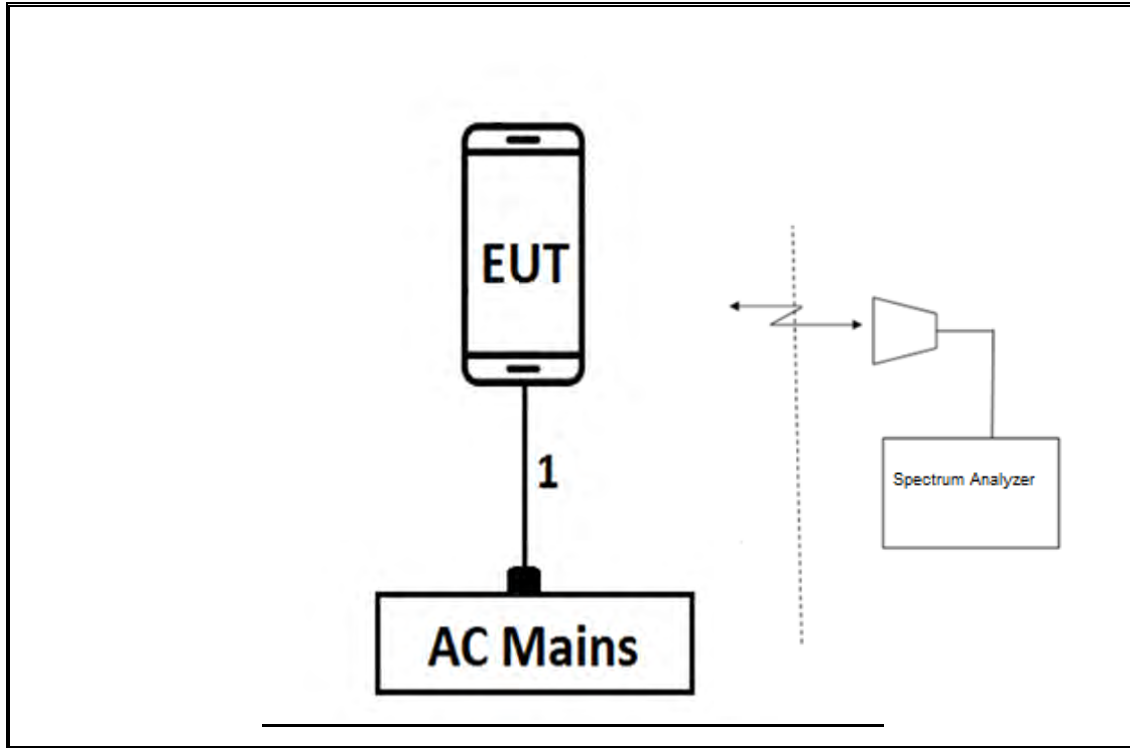

TEST SETUP

For radiated tests: All support equipment were removed after the EUT programmed. The test software exercises the radio.

6. MEASUREMENT METHOD

On Time and Duty Cycle: KDB 558074 D01 v04, Section 6.

6 dB BW: KDB 558074 D01 v04, Section 8.1.

99% BW: ANSI C63.10-2013, Section 6.9.3.

Output Power: KDB 558074 D01 v04, Section 9.2.3.2.

Power Spectral Density: KDB 558074 D01 v04, Section 10.3.

Out-of-band emissions in non-restricted bands: KDB 558074 D01 v04, Section 11.1 (b).

Out-of-band emissions in restricted bands: KDB 558074 D01 v04, Section 12.1.

Band-edge: KDB 558074 D01 v04, Section 12.1.

AC Power Line Conducted Emissions: ANSI C63.10-2013, Section 6.2.

7. TEST AND MEASUREMENT EQUIPMENT

The following test and measurement equipment was utilized for the tests documented in this report:

TEST EQUIPMENT LIST				
Description	Manufacturer	Model	ID Num	Cal Due
Amplifier, 100kHz to 1GHz, 32dB	Hewlet Packard	8447D	T15	08/14/2018
Antenna, Broadband Hybrid, 30MHz to 2000MHz	Sunol Sciences Corp.	JB1	T130	10/16/2018
Antenna, Horn 1-18GHz	ETS-Lindgren	3117	T345	04/25/2019
RF Amplifier	MITEQ	AFS42-00101800-25-S-42	T1165	04/23/2019
Amplifier, 1 to 8GHz, 35dB	Miteq Inc.	AMF-4D-01000800-30-29P	T1573	04/03/2019
Spectrum Analyzer, PXA, 3Hz to 44GHz	Agilent (Keysight) Technologies	N9030A	T1450	02/05/2019
Spectrum Analyzer, PXA, 3Hz to 44GHz	Agilent (Keysight) Technologies	N9030A	T1113	12/21/2018
Spectrum Analyzer, PSA, 3Hz to 44GHz	Agilent (Keysight) Technologies	N9030A	T1466	04/16/2019
Power Meter, P-series single channel	Agilent (Keysight) Technologies	N1911A	T1271	07/17/2019
Power Sensor, P-series, 50MHz to 18GHz, Wideband	Agilent (Keysight) Technologies	N1921A	T1225	04/10/2019
Filter, HPF 3.0GHz	MICRO-TRONICS	HPM17543	T486	04/03/2019
Antenna, Active Loop 9kHz-30MHz	Com-Power Corp.	AL-130R	T1866	10/10/2018
18 - 26.5 GHz Horn Antenna	Seavey Division	MWH-1826/B	T89	01/18/2019
Pre-Amp 1-26.5 GHz	Agilent	8449B	T404	03/09/2019
EMI Reciever	Rohde & Schwarz	ESR	T1436	02/21/2019
L.I.S.N.	FCC INC.	FCC LISN 50/250	T1310	06/15/2019
L.I.S.N.	FCC INC.	FCC LISN 50/250	T24	03/06/2019
Thermometer - Digital	Control Company	14-650-118	PRE0177862	02/22/2019

Test Software List			
Description	Manufacturer	Model	Version
Radiated Software	UL	UL EMC	Ver 9.5, Dec 01, 2016
Antenna Port Software	UL	UL RF	Ver 8.4, June 12, 2018

8. ANTENNA PORT TEST RESULTS

8.1. ON TIME AND DUTY CYCLE

LIMITS

None; for reporting purposes only.

PROCEDURE

KDB 789033 Zero-Span Spectrum Analyzer Method.

ON TIME AND DUTY CYCLE RESULTS

Mode	ON Time B (msec)	Period (msec)	Duty Cycle x (linear)	Duty Cycle (%)	Duty Cycle Correction Factor (dB)	1/B Minimum VBW (kHz)
2.4GHz Band						
802.11b 1TX	8.108	8.108	1.000	100.00%	0.00	0.010
802.11g 1TX	2.029	2.065	0.983	98.26%	0.00	0.010
802.11n HT20 1TX	2.509	2.573	0.975	97.51%	0.11	0.399

DUTY CYCLE PLOTS

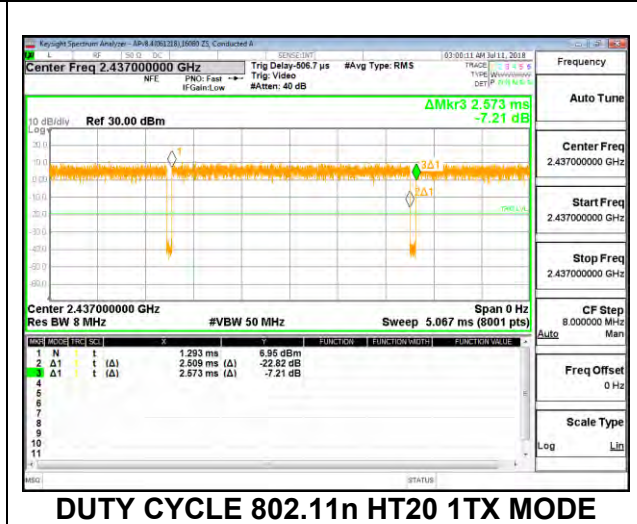
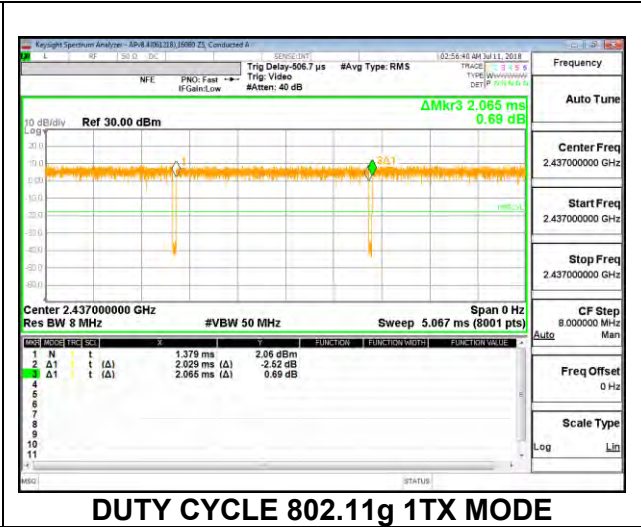
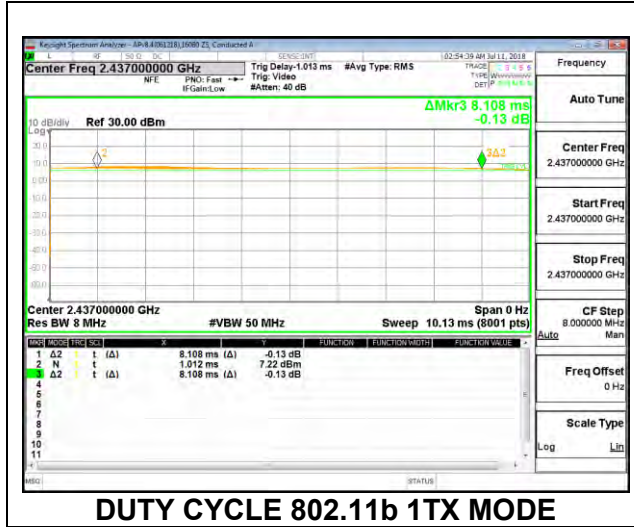

8.2. 99% BANDWIDTH

LIMITS

None; for reporting purposes only.

RESULTS

8.2.1. 802.11b MODE

2TX Antenna 1 + Antenna 2 CDD MODE

Channel	Frequency (MHz)	99% Bandwidth Chain 0 (MHz)	99% Bandwidth Chain 1 (MHz)
Low 1	2412	14.036	13.857
Mid 6	2437	13.669	13.658
High 11	2462	13.464	13.611
High 12	2467	13.544	13.639
High 13	2472	13.934	13.801
Worst		14.036	13.857

LOW CHANNEL 1

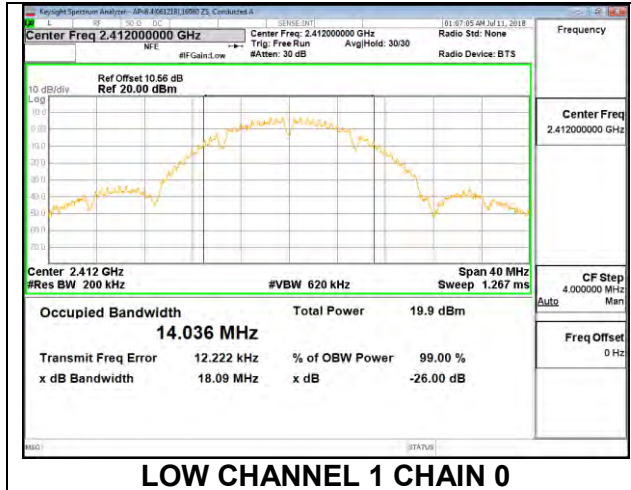

LOW CHANNEL 1 CHAIN 0

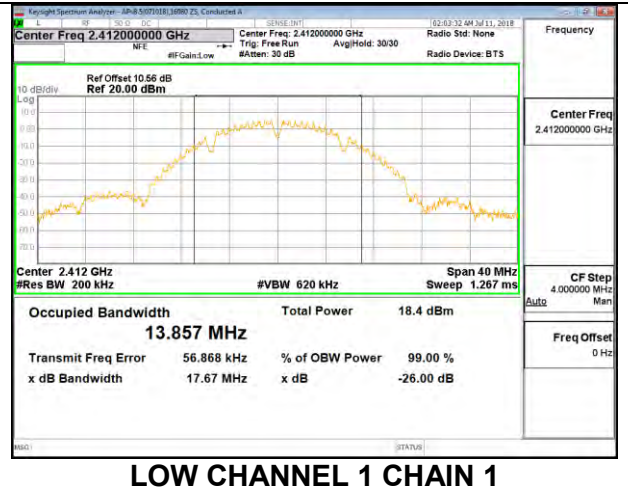

LOW CHANNEL 1 CHAIN 1

MID CHANNEL 6

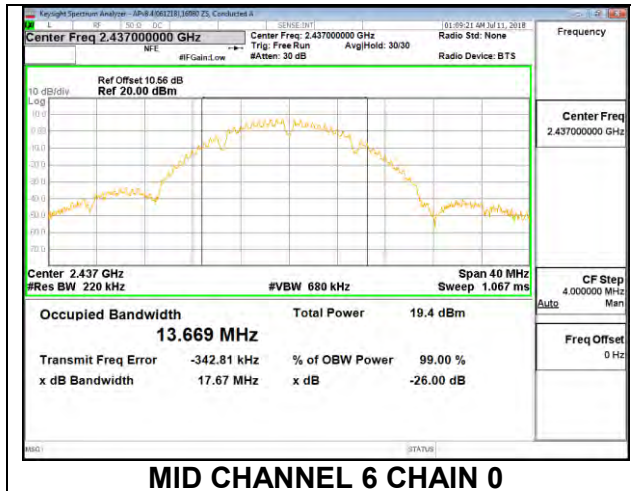

MID CHANNEL 6 CHAIN 0

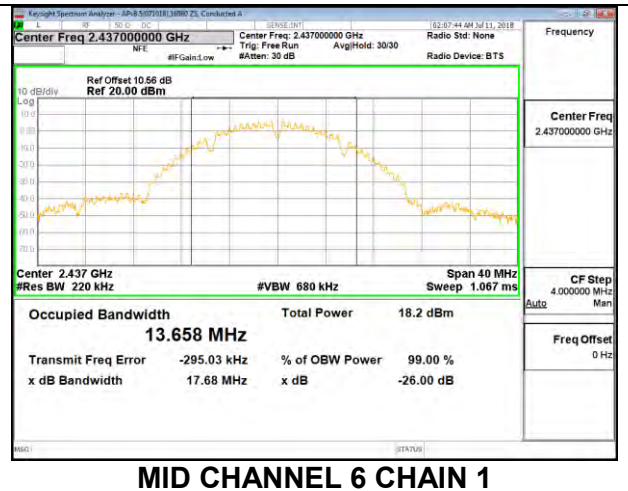

MID CHANNEL 6 CHAIN 1

HIGH CHANNEL 11

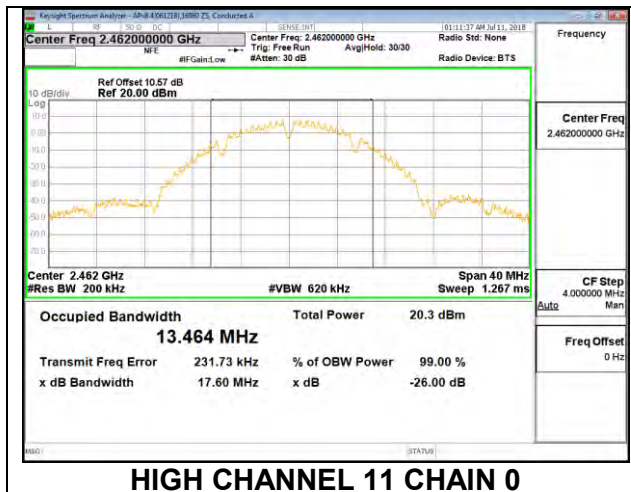

HIGH CHANNEL 11 CHAIN 0

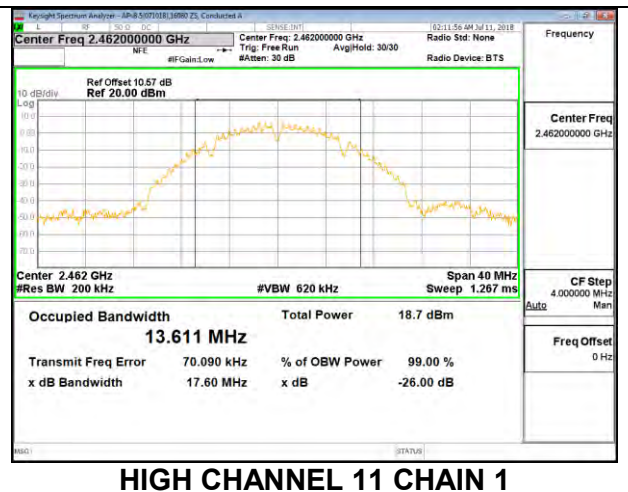

HIGH CHANNEL 11 CHAIN 1

HIGH CHANNEL 12

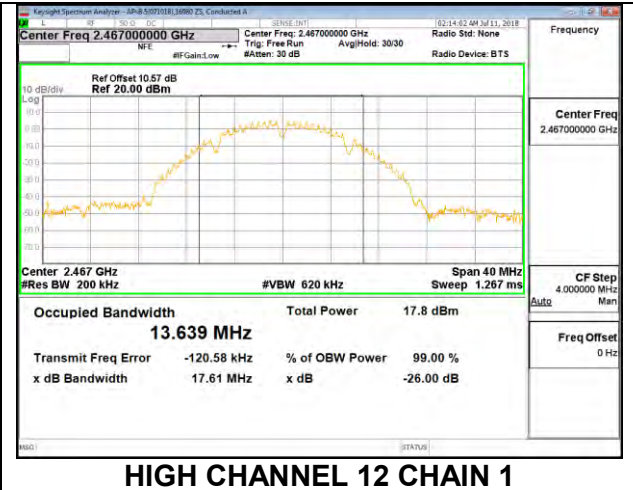
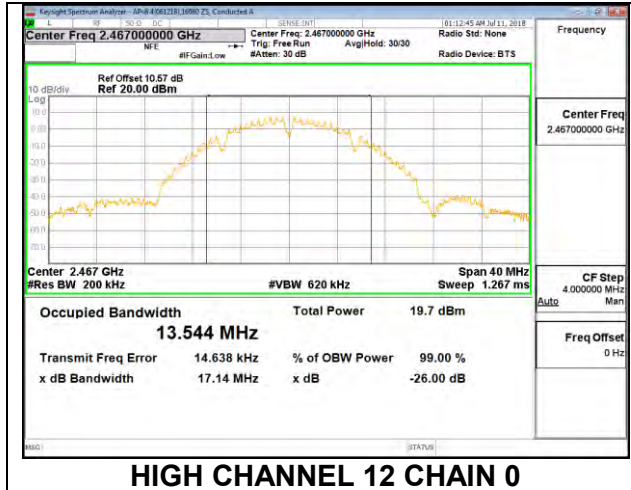

HIGH CHANNEL 13

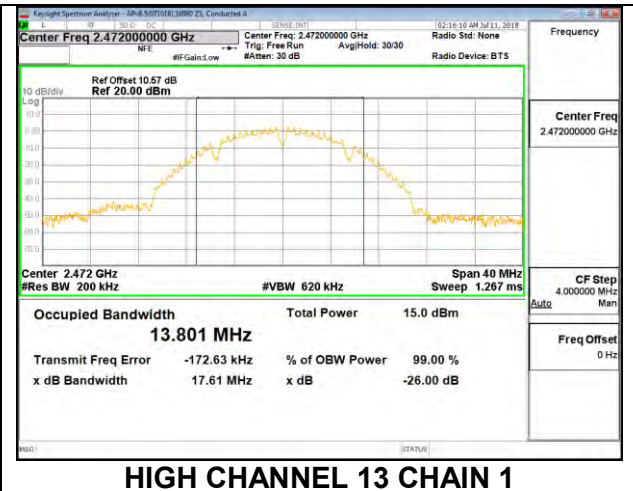
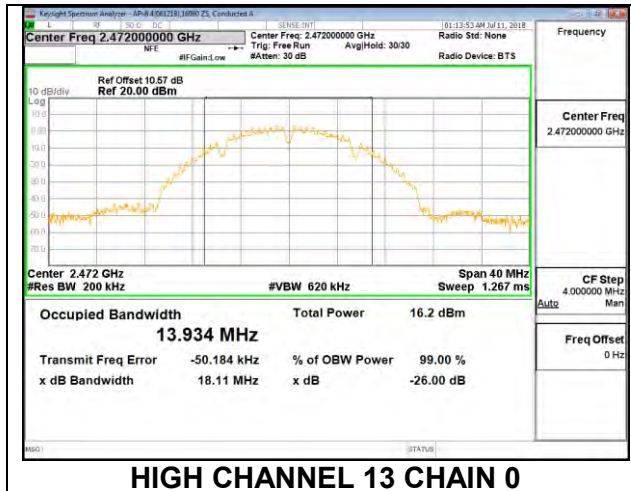

8.2.2. 802.11g MODE

2TX Antenna 1 + Antenna 2 CDD MODE

Channel	Frequency (MHz)	99% Bandwidth Chain 0 (MHz)	99% Bandwidth Chain 1 (MHz)
Low 1	2412	16.614	16.573
Low 2	2417	16.699	16.631
Mid 6	2437	16.574	16.650
High 11	2462	16.459	16.470
High 12	2467	16.459	16.505
High 13	2472	16.574	16.524
Worst		16.699	16.650

LOW CHANNEL 1

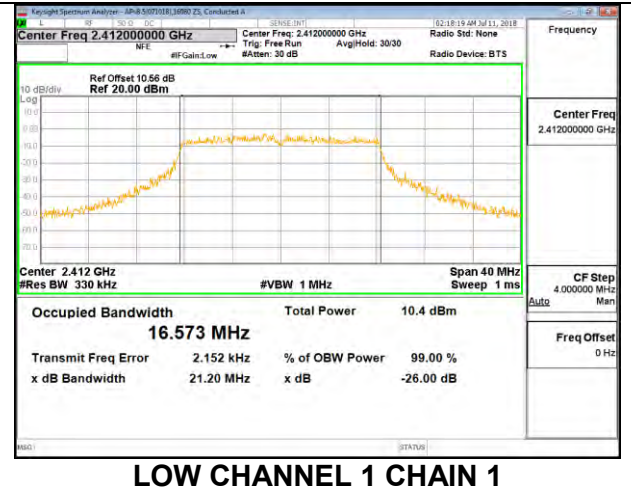
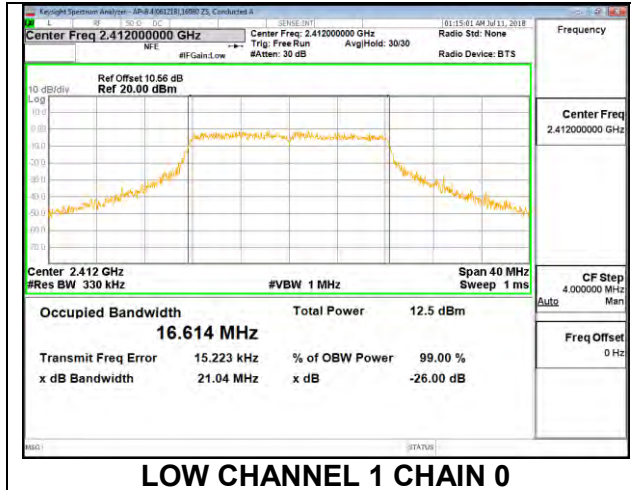

LOW CHANNEL 2

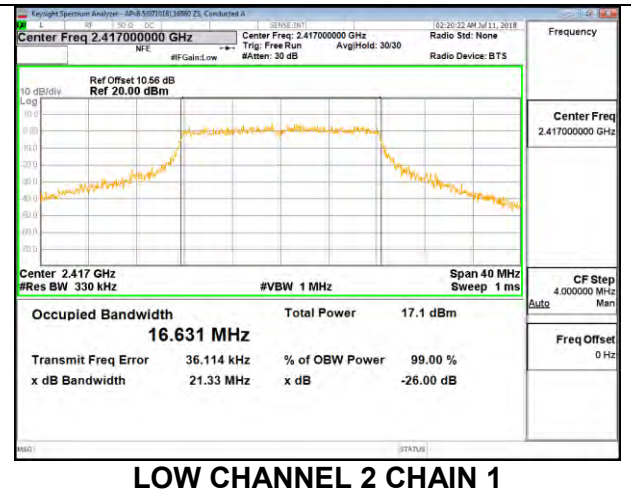
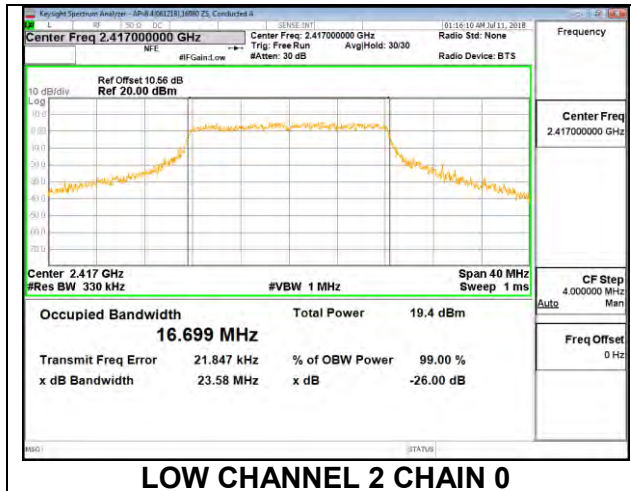

MID CHANNEL 6

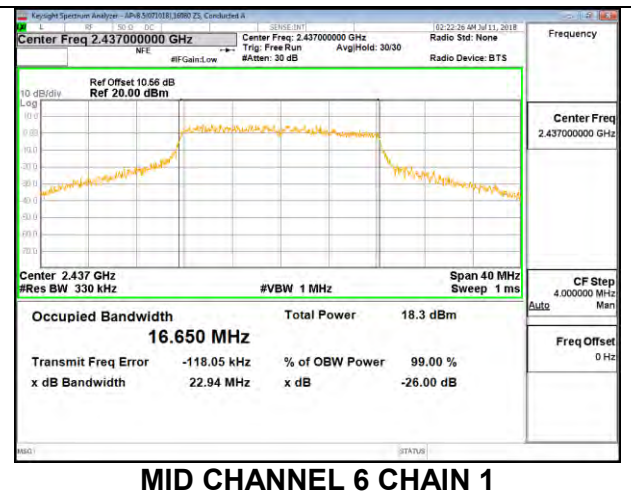
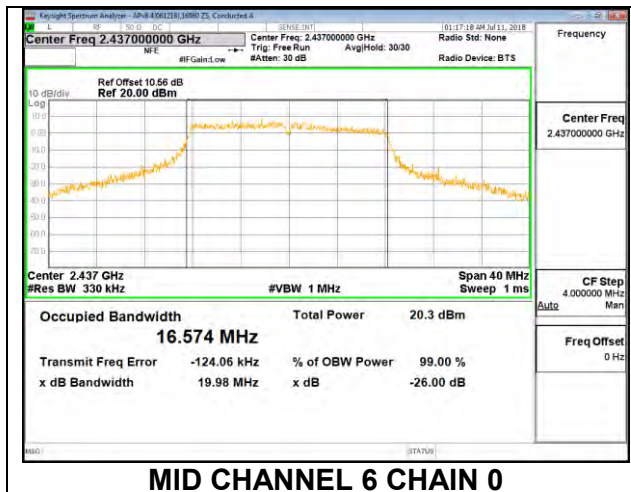

HIGH CHANNEL 11

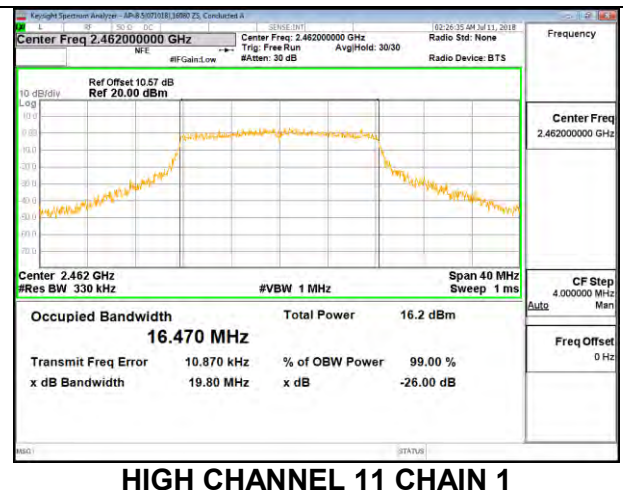
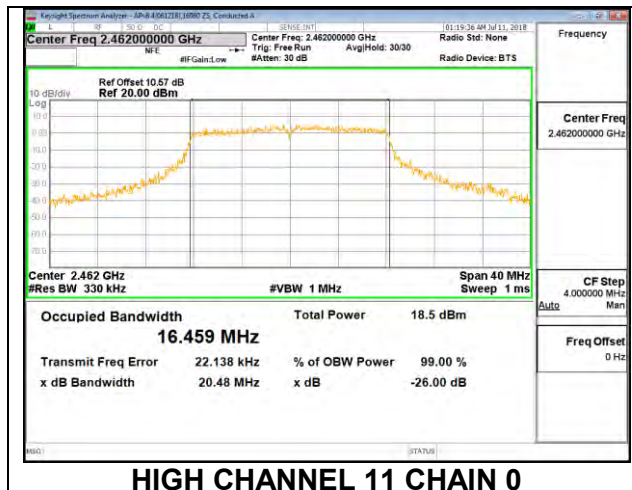

HIGH CHANNEL 12

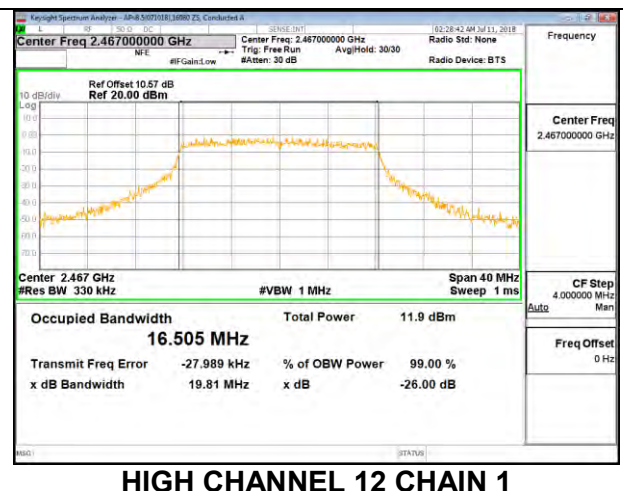
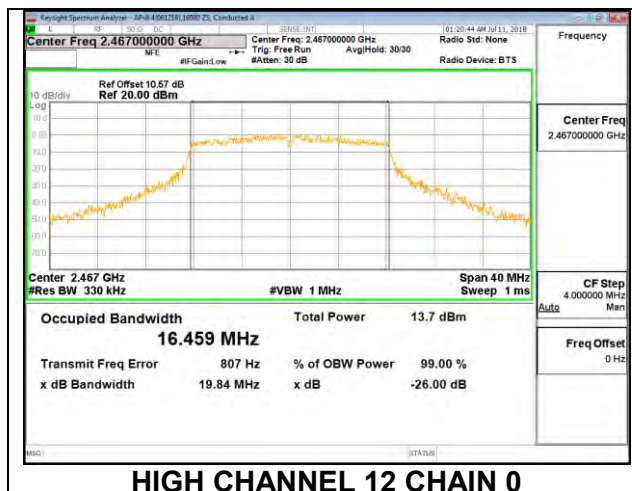

HIGH CHANNEL 13

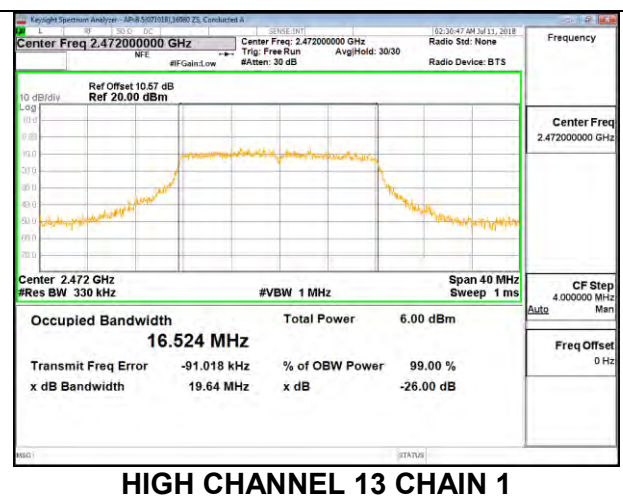
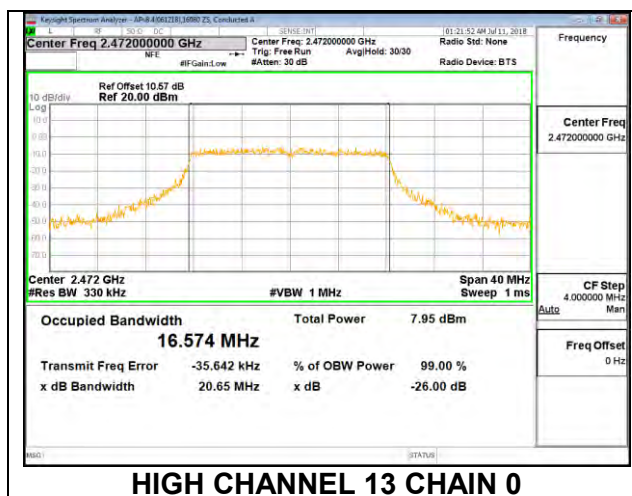

8.2.3. 802.11n HT20 MODE

2TX Antenna 1 + Antenna 2 CDD MODE

Channel	Frequency (MHz)	99% Bandwidth Chain 0 (MHz)	99% Bandwidth Chain 1 (MHz)
Low 1	2412	17.808	17.837
Low 2	2417	17.969	17.830
Mid 6	2437	17.766	17.822
High 11	2462	17.656	17.696
High 12	2467	17.654	17.641
High 13	2472	17.748	17.754
Worst		17.969	17.837

LOW CHANNEL 1

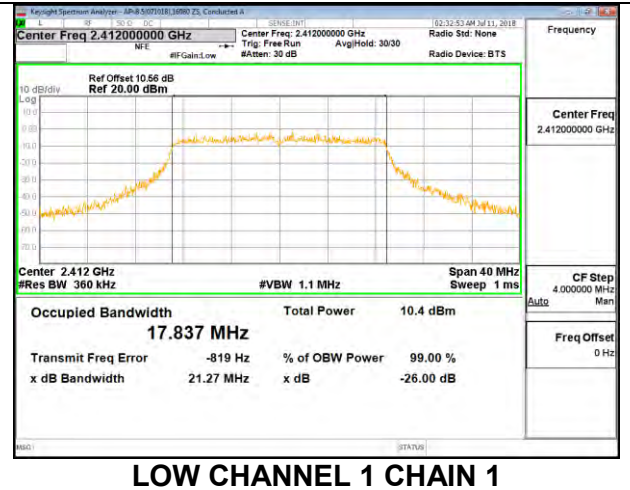
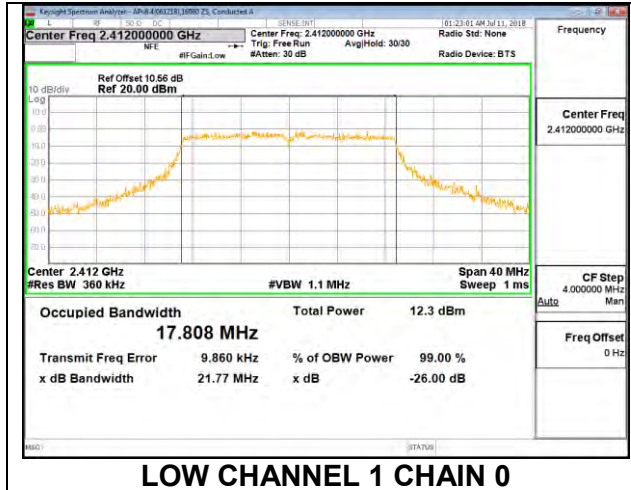

LOW CHANNEL 2

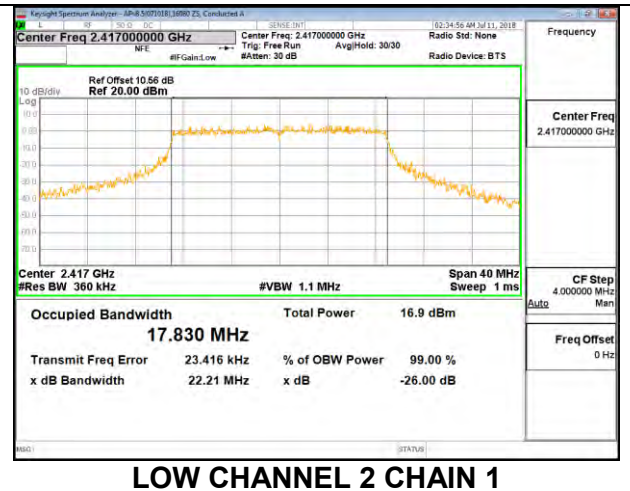
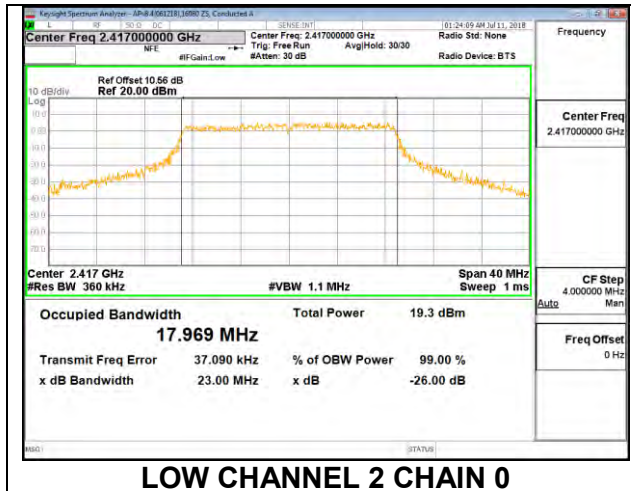

MID CHANNEL 6

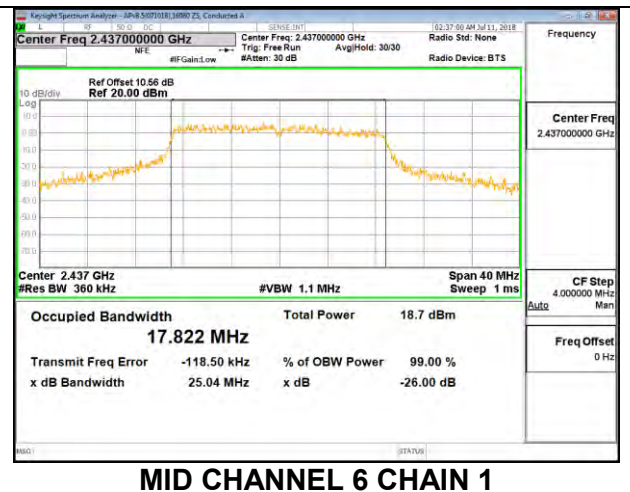
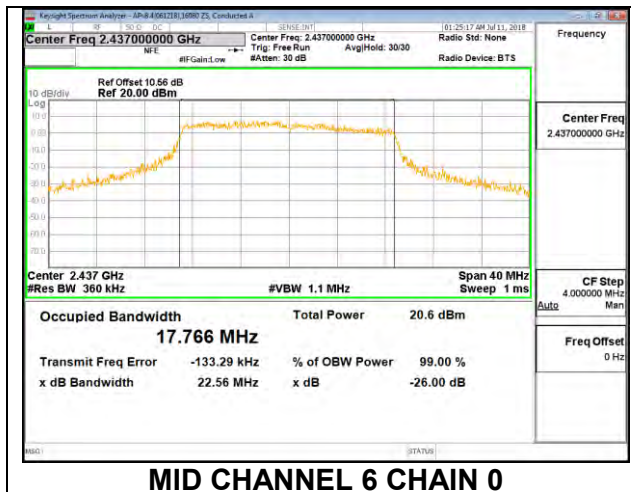

HIGH CHANNEL 11

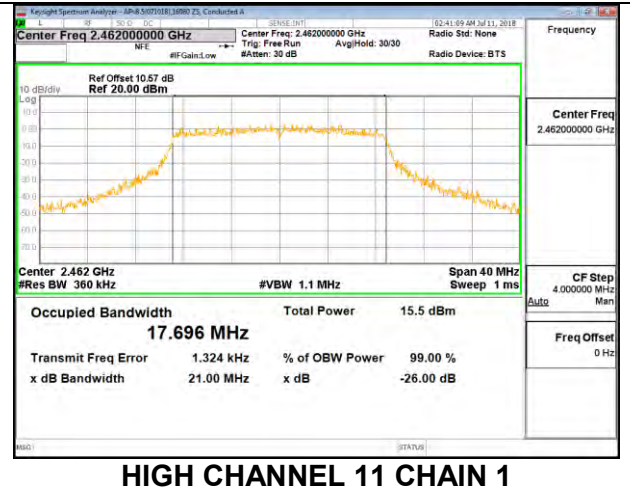
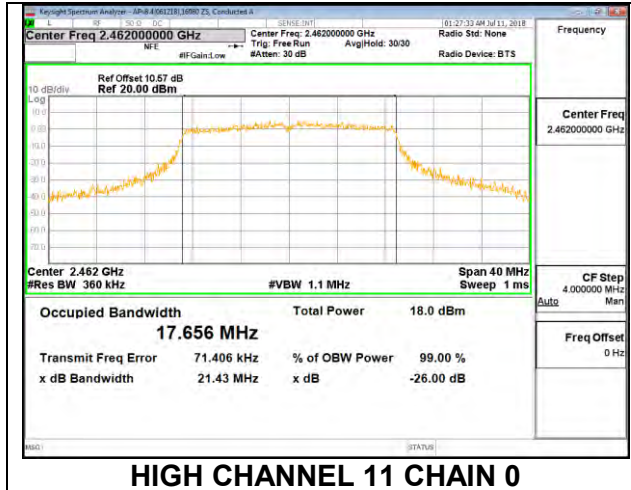

HIGH CHANNEL 12

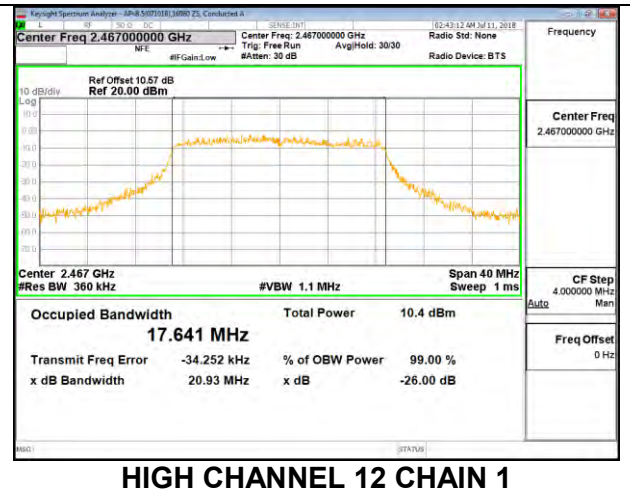
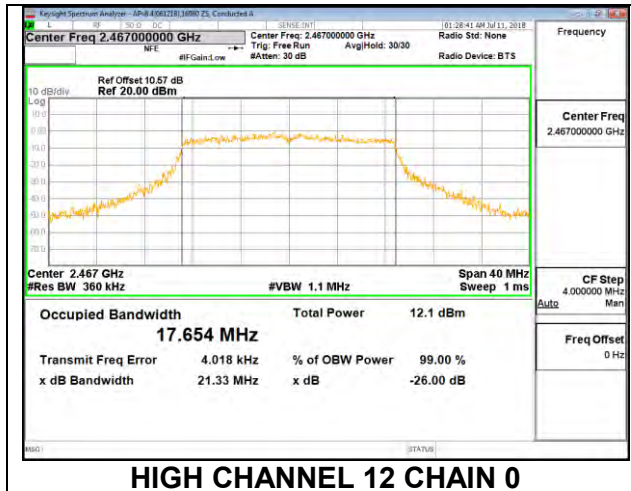

HIGH CHANNEL 13

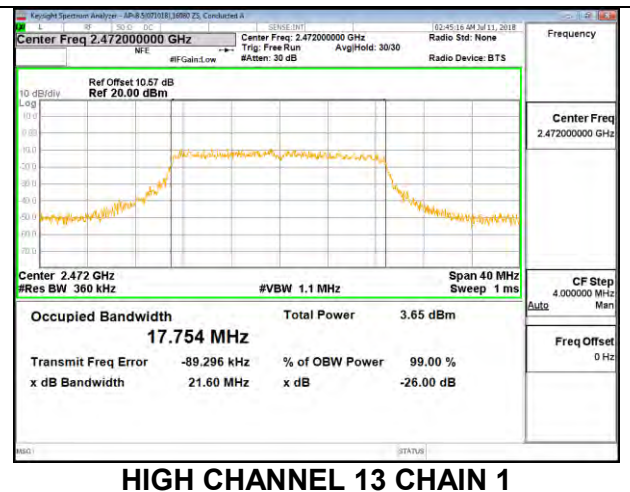
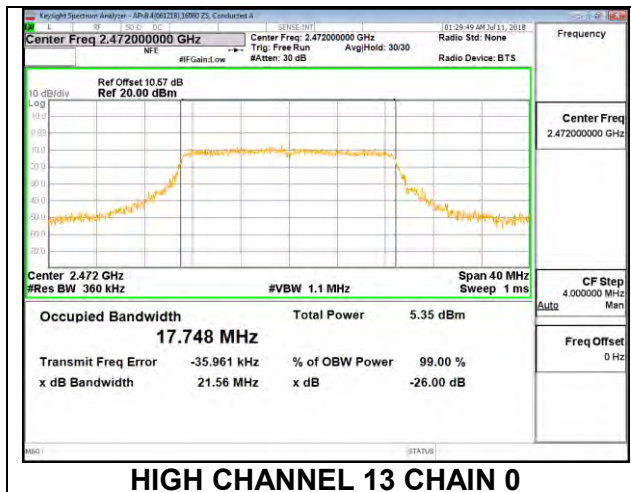

8.3. 6 dB BANDWIDTH

LIMITS

FCC §15.247 (a) (2)

The minimum 6 dB bandwidth shall be at least 500 kHz.

RESULTS

8.3.1. 802.11b MODE

2TX Antenna 1 + Antenna 2 CDD MODE

Channel	Frequency (MHz)	6 dB BW Chain 0 (MHz)	6 dB BW Chain 1 (MHz)	Minimum Limit (MHz)
Low 1	2412	8.60	8.12	0.5
Mid 6	2437	8.12	8.12	0.5
High 11	2462	8.76	8.12	0.5
High 12	2467	8.12	8.48	0.5
High 13	2472	8.04	8.52	0.5

LOW CHANNEL 1

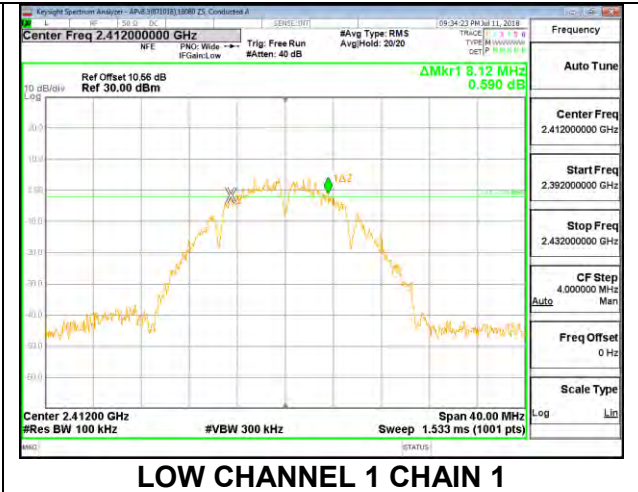
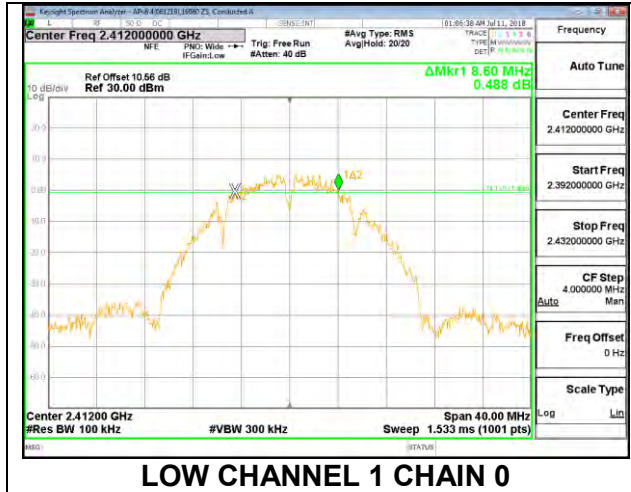

MID CHANNEL 6

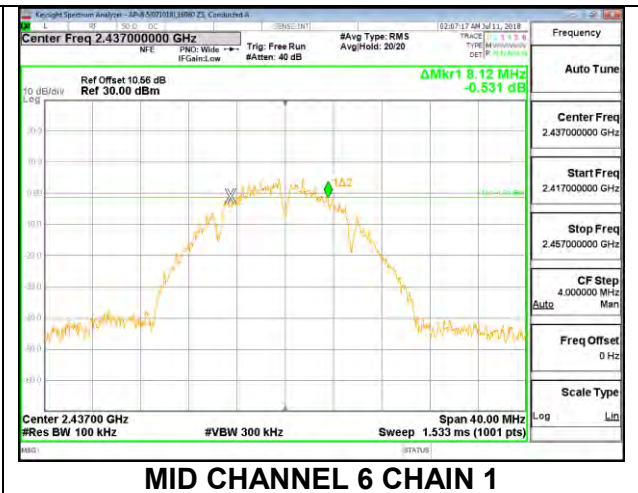
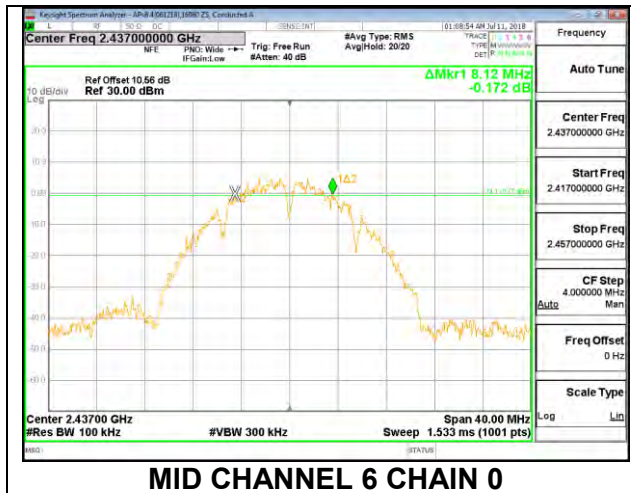

HIGH CHANNEL 11

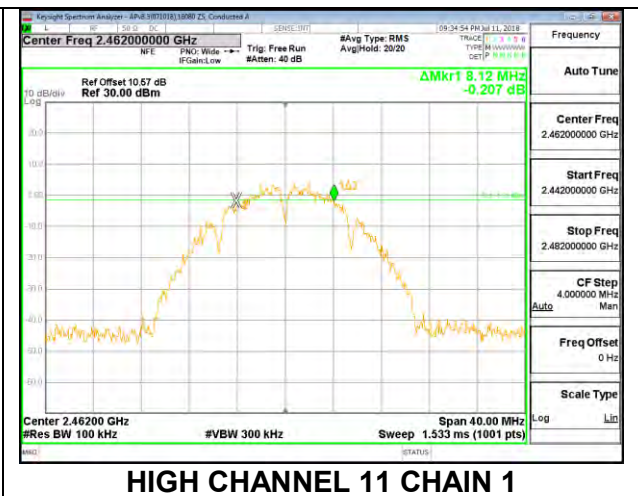
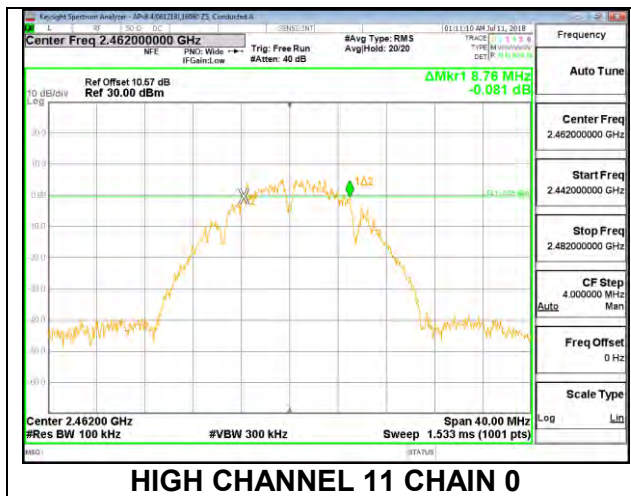

HIGH CHANNEL 12

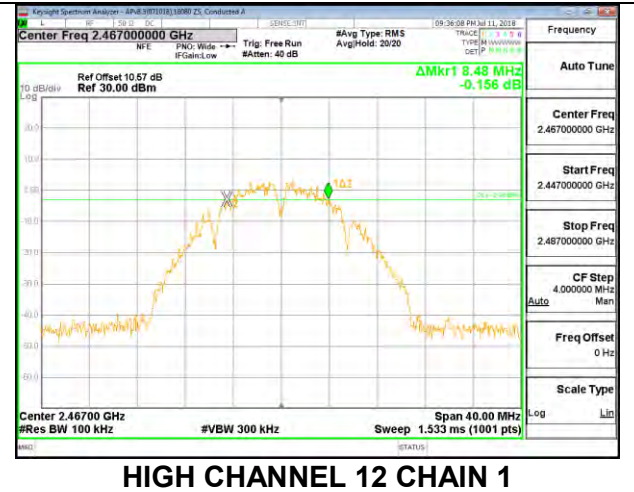
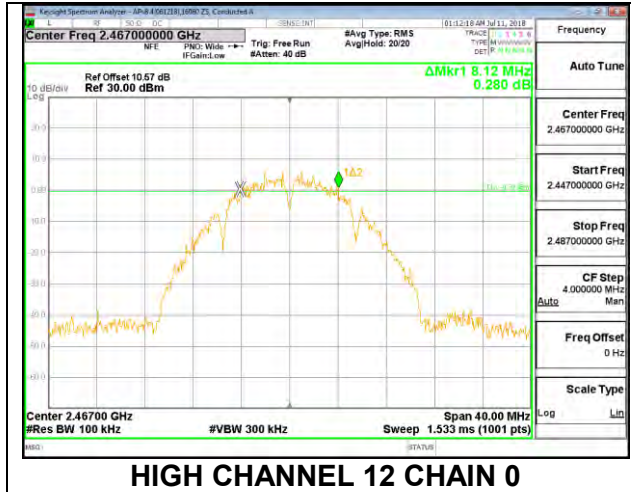

HIGH CHANNEL 13

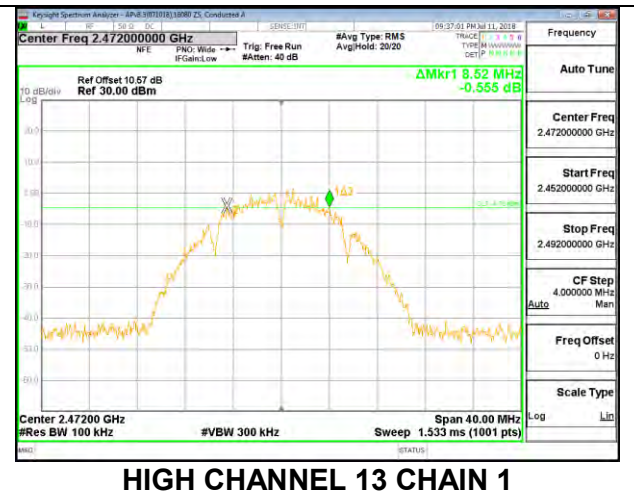
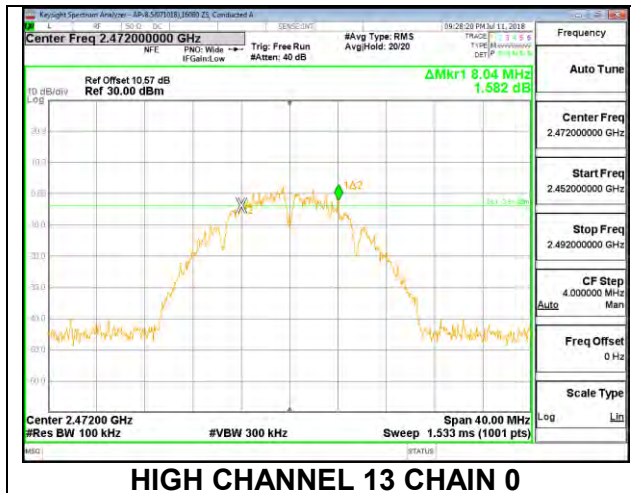

8.3.2. 802.11g MODE

2TX Antenna 1 + Antenna 2 CDD MODE

Channel	Frequency (MHz)	6 dB BW Chain 0 (MHz)	6 dB BW Chain 1 (MHz)	Minimum Limit (MHz)
Low 1	2412	16.52	16.36	0.5
Low 2	2417	16.40	16.32	0.5
Mid 6	2437	16.44	16.36	0.5
High 11	2462	16.40	16.32	0.5
High 12	2467	16.36	16.36	0.5
High 13	2472	16.48	16.40	0.5

LOW CHANNEL 1

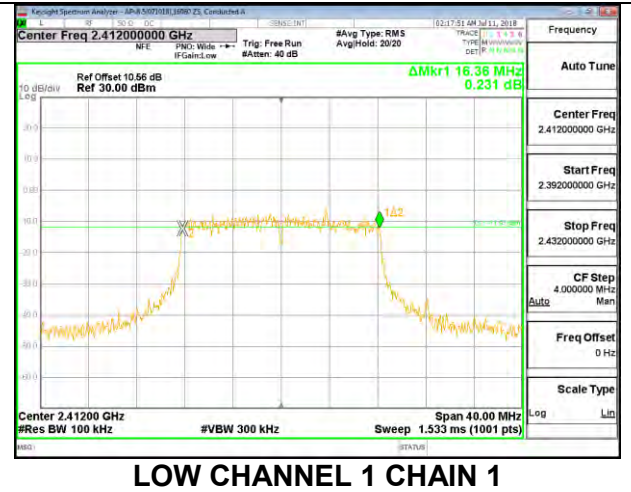
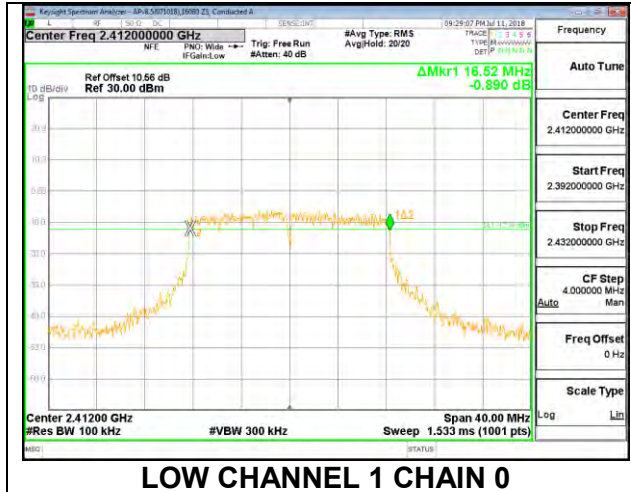

LOW CHANNEL 2

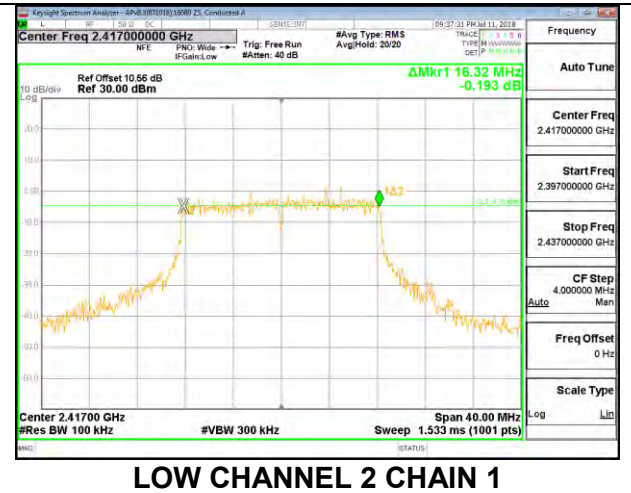
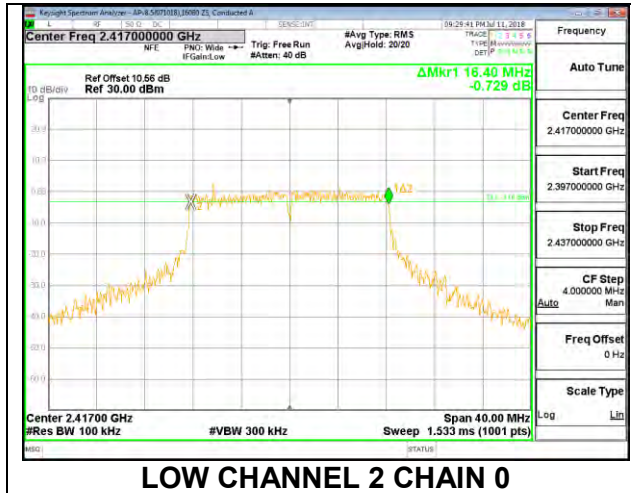

MID CHANNEL 6

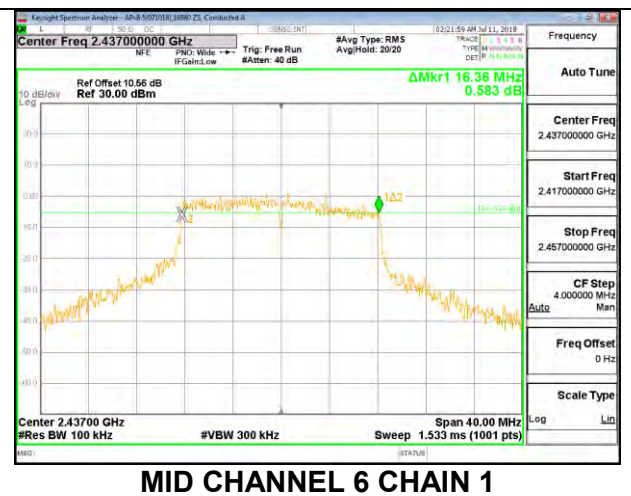
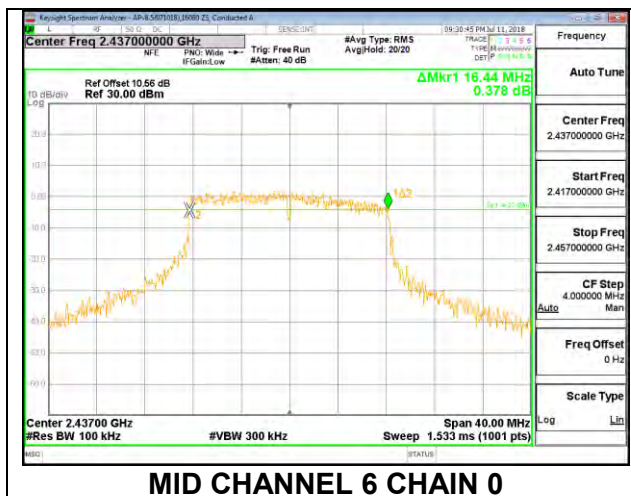

HIGH CHANNEL 11

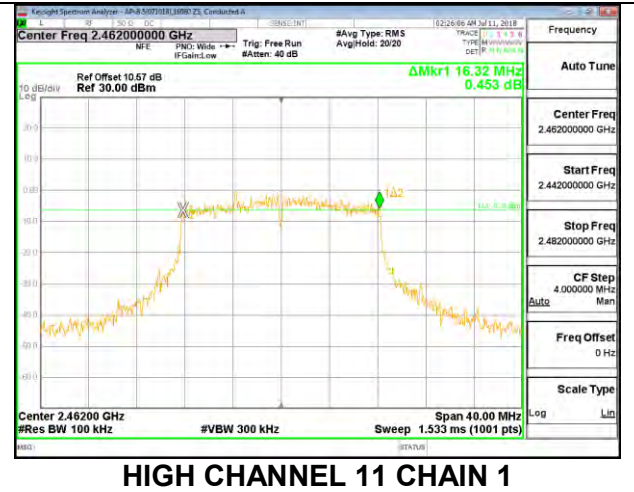
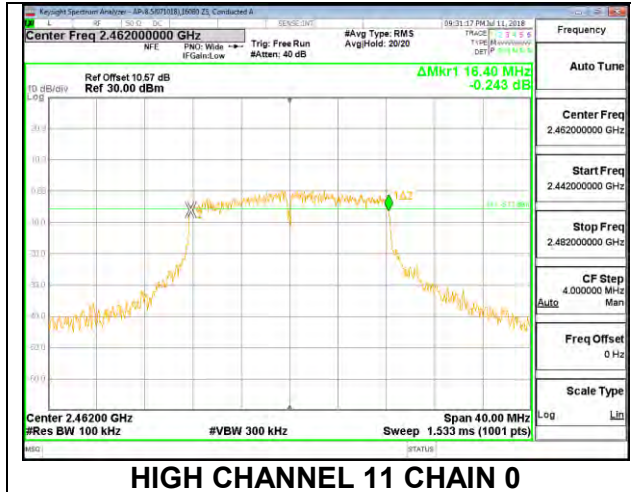

HIGH CHANNEL 12

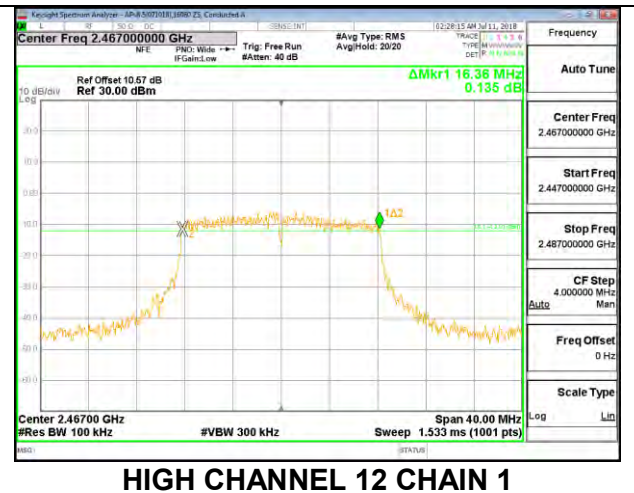
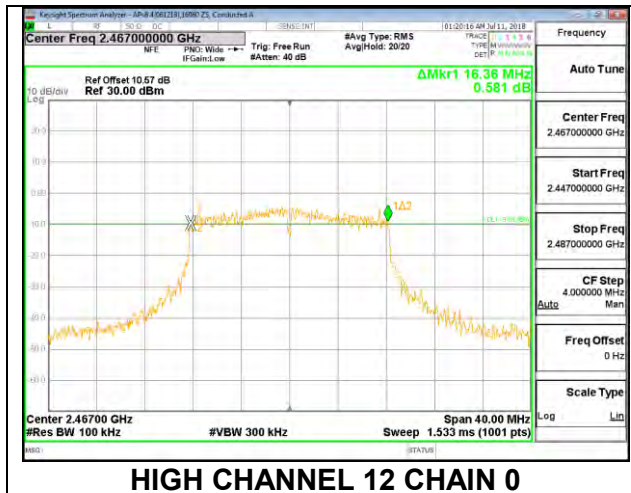

HIGH CHANNEL 13

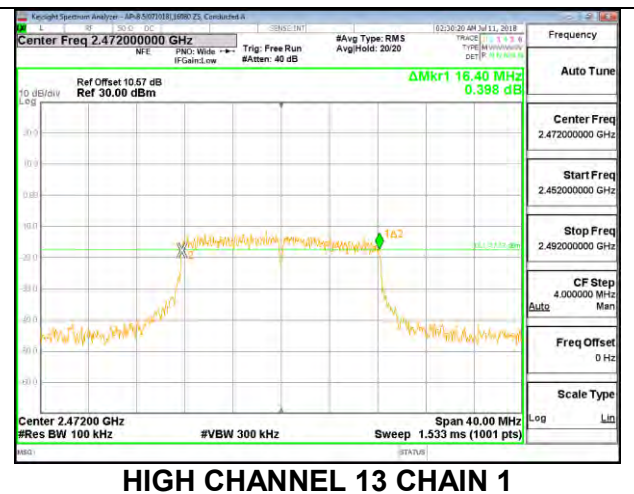
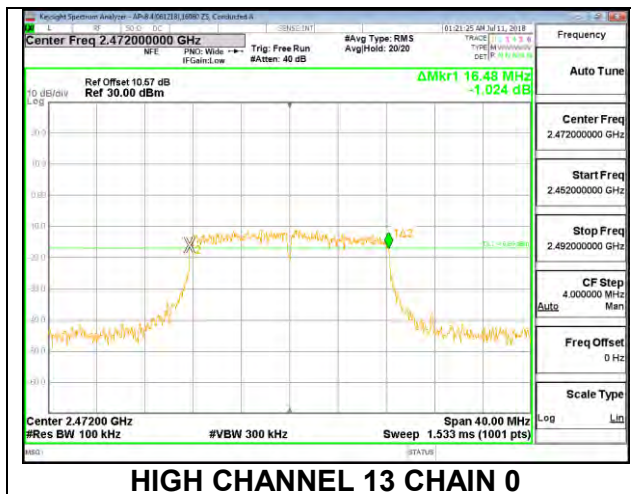

8.3.3. 802.11n HT20 MODE

2TX Antenna 1 + Antenna 2 CDD MODE

Channel	Frequency (MHz)	6 dB BW Chain 0 (MHz)	6 dB BW Chain 1 (MHz)	Minimum Limit (MHz)
Low 1	2412	17.64	17.64	0.5
Low 2	2417	17.68	17.44	0.5
Mid 6	2437	17.68	17.64	0.5
High 11	2462	17.60	17.60	0.5
High 12	2467	17.56	17.60	0.5
High 13	2472	17.60	17.72	0.5

LOW CHANNEL 1

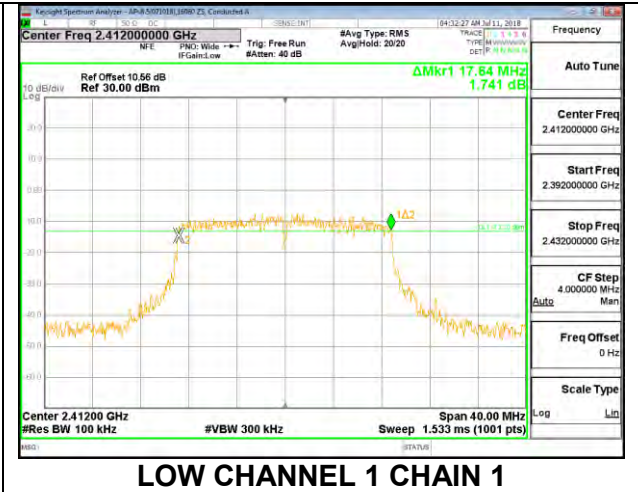
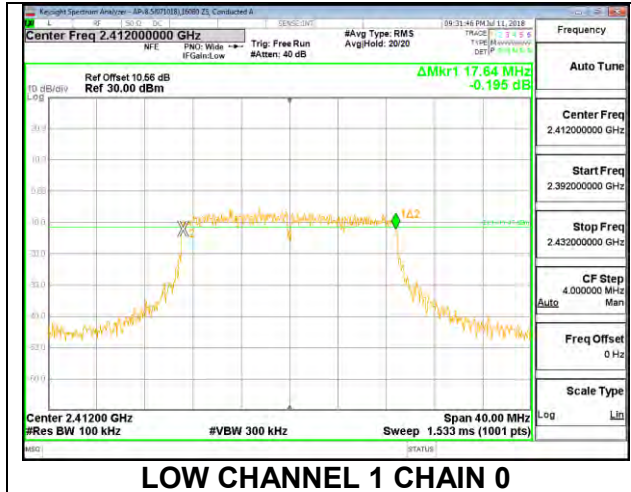

LOW CHANNEL 2

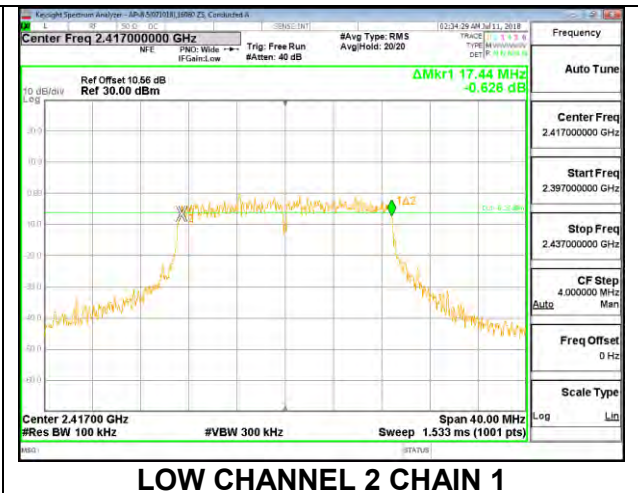
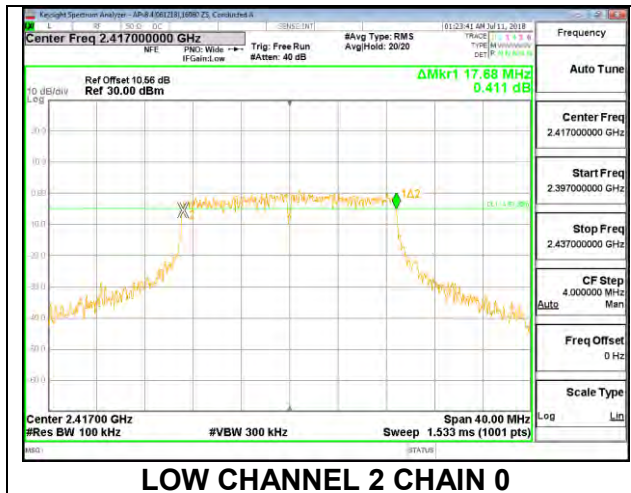

MID CHANNEL 6

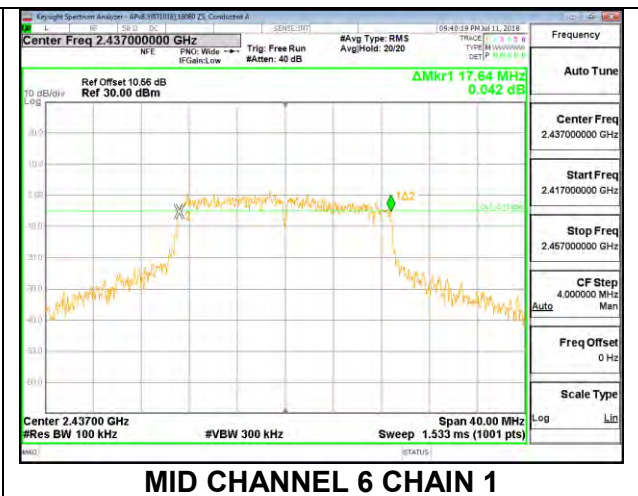
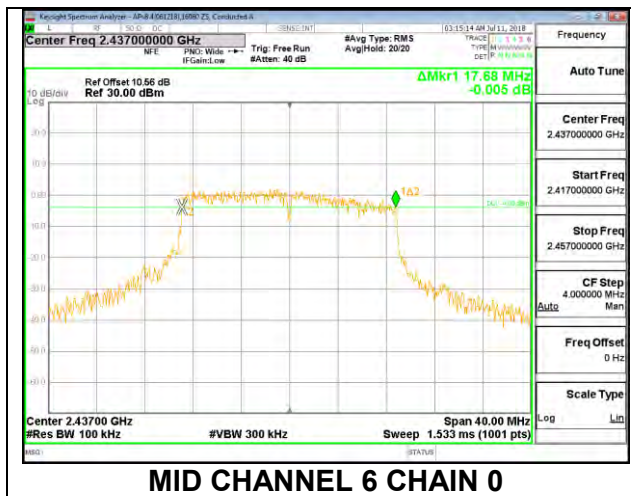

HIGH CHANNEL 11

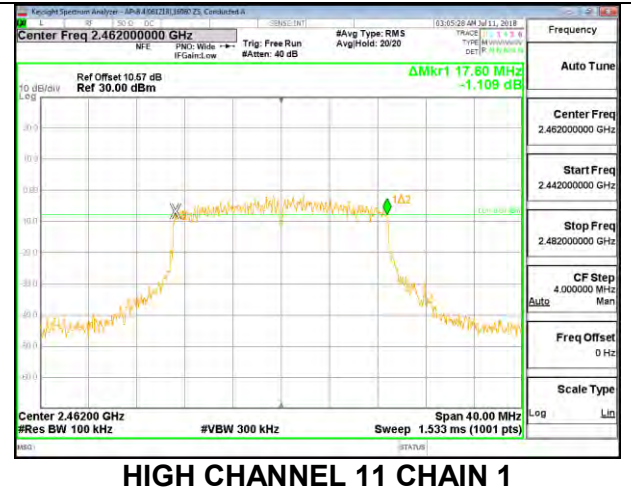
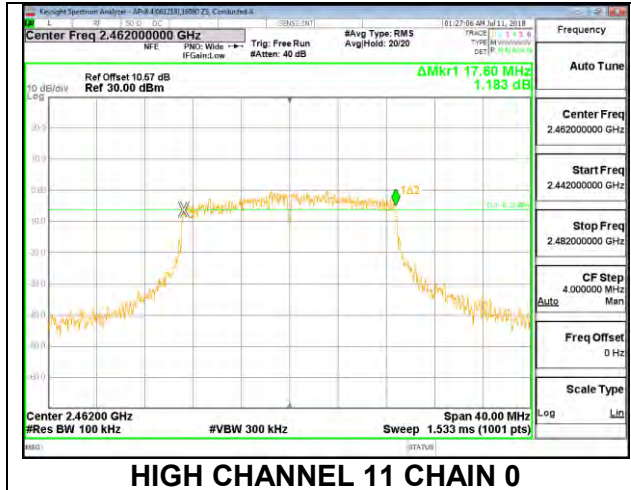

HIGH CHANNEL 12

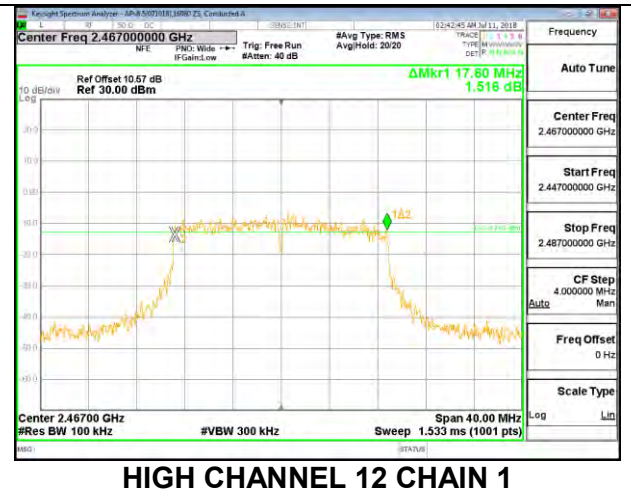
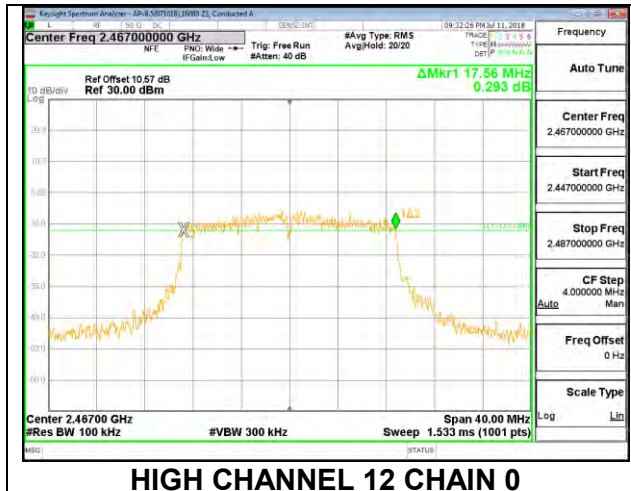

HIGH CHANNEL 13

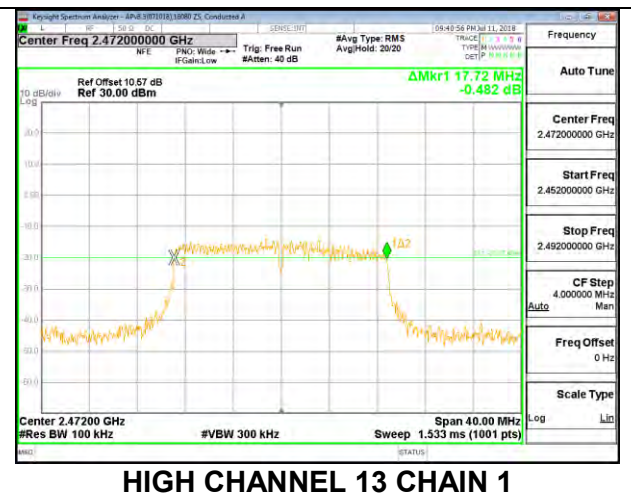
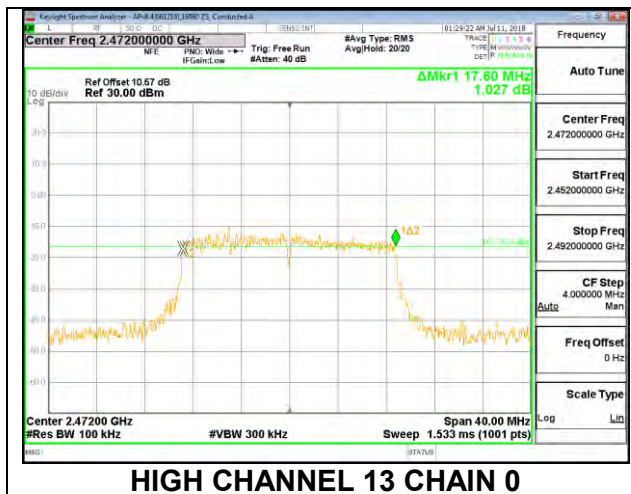

8.4. OUTPUT POWER

LIMITS

FCC §15.247 (b) (3)

For systems using digital modulation in the 902–928 MHz, 2400–2483.5 MHz, and 5725–5850 MHz bands: 1 Watt, based on the use of antennas with directional gains that do not exceed 6 dBi. If transmitting antennas of directional gain greater than 6 dBi are used, the conducted output power from the intentional radiator shall be reduced by the amount in dB that the directional gain of the antenna exceeds 6 dBi.

TEST PROCEDURE

The transmitter output is connected to a power meter. The cable assembly insertion loss was entered as an offset in the power meter to allow for a gated average reading of power.

DIRECTIONAL ANTENNA GAIN

Tx chains are uncorrelated for power and correlated for PSD due to the device supporting CDD in all MIMO modes. The directional gains are as follows:

Band (GHz)	Chain 0 Antenna Gain (dBi)	Chain 1 Antenna Gain (dBi)	Uncorrelated Chains Directional Gain (dBi)
2.4	-1.50	-10.40	-3.98

RESULTS

ID:	GE43578	Date:	7/7/2018
------------	---------	--------------	----------

8.4.1. 802.11b MODE

2TX Antenna 1 + Antenna 2 CDD MODE

Limits

Channel	Frequency (MHz)	Directional Gain (dBi)	FCC/ISED Power Limit (dBm)	ISED EIRP Limit (dBm)	Max Power (dBm)
Low 1	2412	-3.98	30.00	36	30.00
Mid 6	2437	-3.98	30.00	36	30.00
High 11	2462	-3.98	30.00	36	30.00
High 12	2467	-3.98	30.00	36	30.00
High 13	2472	-3.98	30.00	36	30.00

Results

Channel	Frequency (MHz)	Chain 0 Meas Power (dBm)	Chain 1 Meas Power (dBm)	Total Corr'd Power (dBm)	Power Limit (dBm)	Margi (dB)
Low 1	2412	15.82	14.16	18.08	30.00	-11.92
Mid 6	2437	15.94	14.47	18.28	30.00	-11.72
High 11	2462	15.66	14.52	18.14	30.00	-11.86
High 12	2467	15.15	13.74	17.51	30.00	-12.49
High 13	2472	12.28	10.78	14.60	30.00	-15.40

8.4.2. 802.11g MODE

2TX Antenna 1 + Antenna 2 CDD MODE

Limits

Channel	Frequency (MHz)	Directional Gain (dBi)	FCC/ISED Power Limit (dBm)	ISED EIRP Limit (dBm)	Max Power (dBm)
Low 1	2412	-3.98	30.00	36	30.00
Low 2	2417	-3.98	30.00	36	30.00
Mid 6	2437	-3.98	30.00	36	30.00
High 11	2462	-3.98	30.00	36	30.00
High 12	2467	-3.98	30.00	36	30.00
High 13	2472	-3.98	30.00	36	30.00

Results

Channel	Frequency (MHz)	Chain 0 Meas Power (dBm)	Chain 1 Meas Power (dBm)	Total Corr'd Power (dBm)	Power Limit (dBm)	Margi (dB)
Low 1	2412	7.97	6.03	10.12	30.00	-19.88
Low 2	2417	15.01	13.13	17.18	30.00	-12.82
Mid 6	2437	16.17	14.58	18.46	30.00	-11.54
High 11	2462	14.14	12.03	16.22	30.00	-13.78
High 12	2467	9.62	7.08	11.54	30.00	-18.46
High 13	2472	3.41	1.46	5.55	30.00	-24.45

8.4.3. 802.11n HT20 MODE

2TX Antenna 1 + Antenna 2 CDD MODE

Limits

Channel	Frequency (MHz)	Directional Gain (dBi)	FCC/ISED Power Limit (dBm)	ISED EIRP Limit (dBm)	Max Power (dBm)
Low 1	2412	-3.98	30.00	36	30.00
Low 2	2417	-3.98	30.00	36	30.00
Mid 6	2437	-3.98	30.00	36	30.00
High 11	2462	-3.98	30.00	36	30.00
High 12	2467	-3.98	30.00	36	30.00
High 13	2472	-3.98	30.00	36	30.00

Results

Channel	Frequency (MHz)	Chain 0 Meas Power (dBm)	Chain 1 Meas Power (dBm)	Total Corr'd Power (dBm)	Power Limit (dBm)	Margi (dB)
Low 1	2412	8.01	5.93	10.10	30.00	-19.90
Low 2	2417	14.96	13.01	17.10	30.00	-12.90
Mid 6	2437	16.05	14.42	18.32	30.00	-11.68
High 11	2462	13.63	11.36	15.65	30.00	-14.35
High 12	2467	8.03	6.18	10.21	30.00	-19.79
High 13	2472	1.34	-0.52	3.52	30.00	-26.48

8.5. POWER SPECTRAL DENSITY

LIMITS

FCC §15.247 (e)

The power spectral density conducted from the transmitter to the antenna shall not be greater than 8 dBm in any 3 kHz band during any time interval of continuous transmission.

RESULTS

8.5.1. 802.11b MODE

2TX Antenna 1 + Antenna 2 CDD MODE

Duty Cycle CF (dB)	0.00	Included in Calculations of Corr'd PSD
---------------------------	------	-----------------------------------------------

PSD Results

Channel	Frequency (MHz)	Chain 0 Meas (dBm/ 3kHz)	Chain 1 Meas (dBm/ 3kHz)	Total Corr'd PSD (dBm/ 3kHz)	Limit (dBm/ 3kHz)	Margin (dB)
Low 1	2412	-6.13	-7.74	-3.85	8.0	-11.9
Mid 6	2437	-6.19	-7.77	-3.90	8.0	-11.9
High 11	2462	-5.82	-7.39	-3.52	8.0	-11.5
High 12	2467	-6.46	-8.13	-4.20	8.0	-12.2
High 13	2472	-9.93	-11.45	-7.61	8.0	-15.6

LOW CHANNEL 1

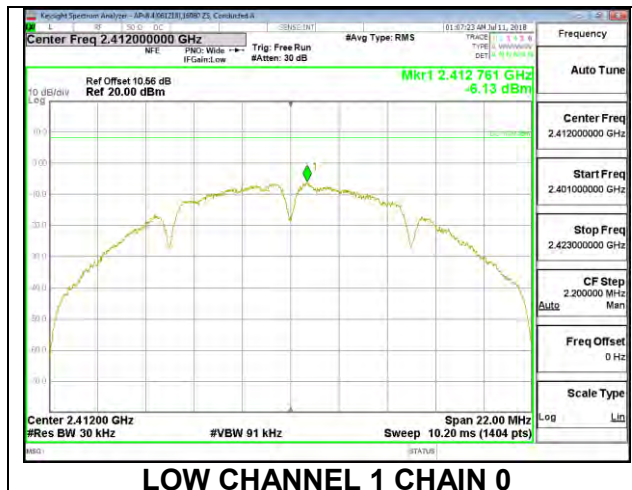

MID CHANNEL 6

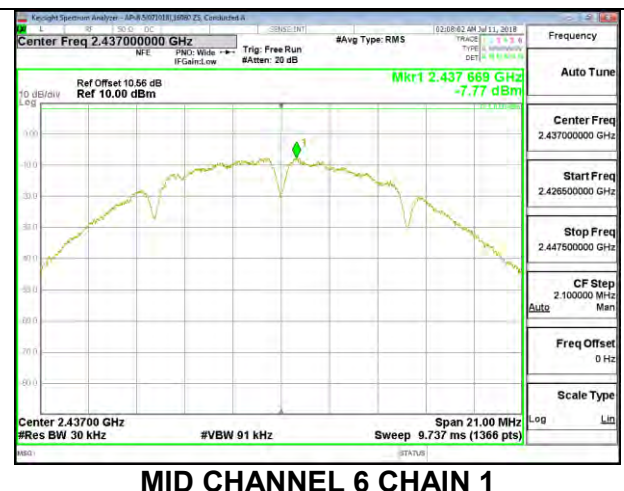
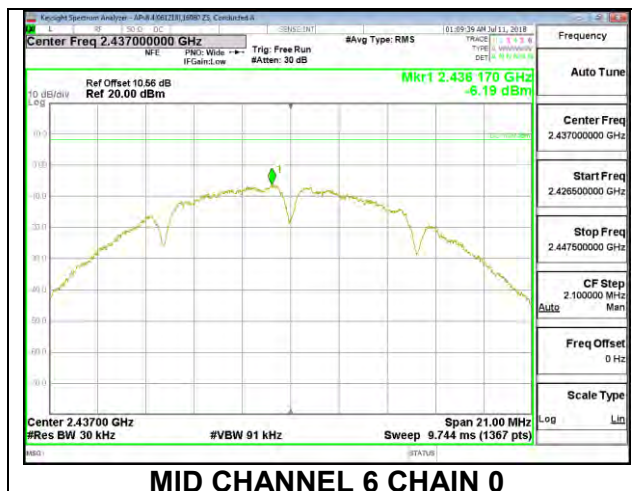

HIGH CHANNEL 11

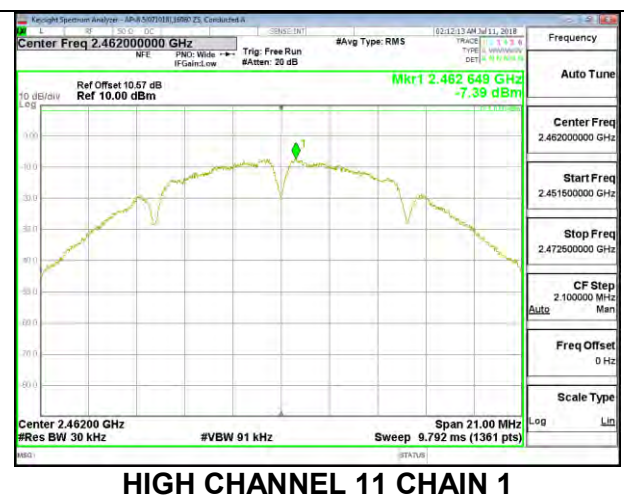
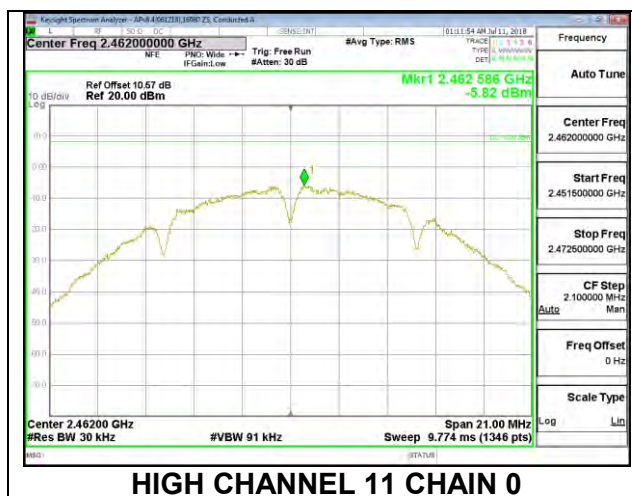

HIGH CHANNEL 12

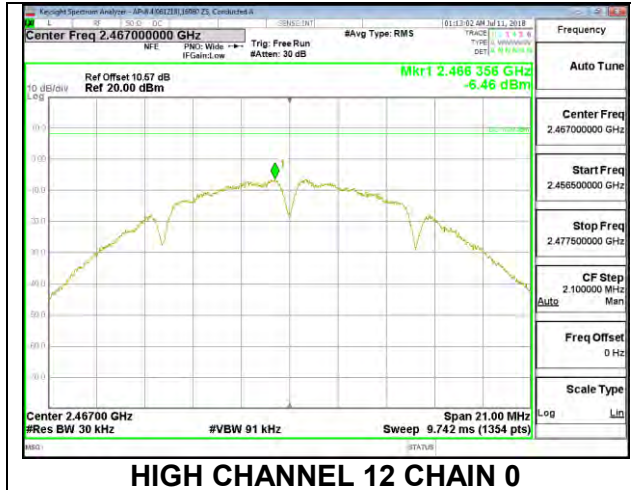

HIGH CHANNEL 13

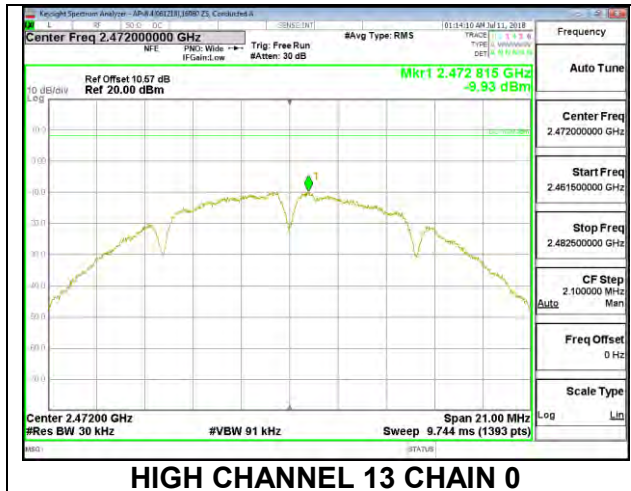

8.5.2. 802.11g MODE

2TX Antenna 1 + Antenna 2 CDD MODE

Duty Cycle CF (dB)	0.00	Included in Calculations of Corr'd PSD
---------------------------	------	-----------------------------------------------

PSD Results

Channel	Frequency (MHz)	Chain 0 Meas (dBm/ 3kHz)	Chain 1 Meas (dBm/ 3kHz)	Total Corr'd PSD (dBm/ 3kHz)	Limit (dBm/ 3kHz)	Margin (dB)
Low 1	2412	-16.11	-18.01	-13.95	8.0	-21.9
Low 2	2417	-8.82	-11.13	-6.81	8.0	-14.8
Mid 6	2437	-8.31	-10.08	-6.10	8.0	-14.1
High 11	2462	-9.25	-11.37	-7.17	8.0	-15.2
High 12	2467	-14.14	-15.88	-11.91	8.0	-19.9
High 13	2472	-20.82	-22.93	-18.74	8.0	-26.7

LOW CHANNEL 1

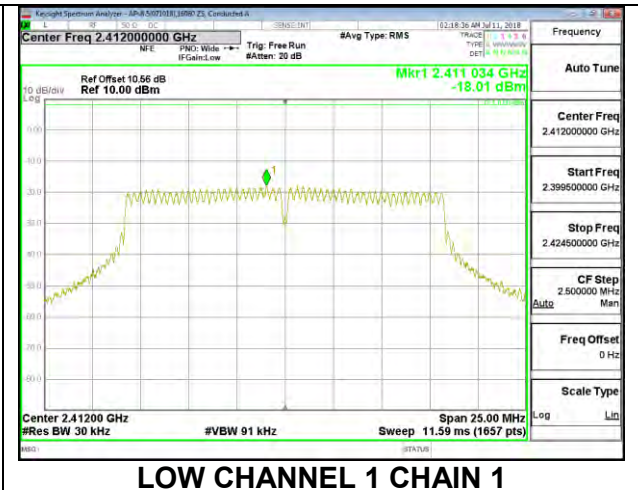
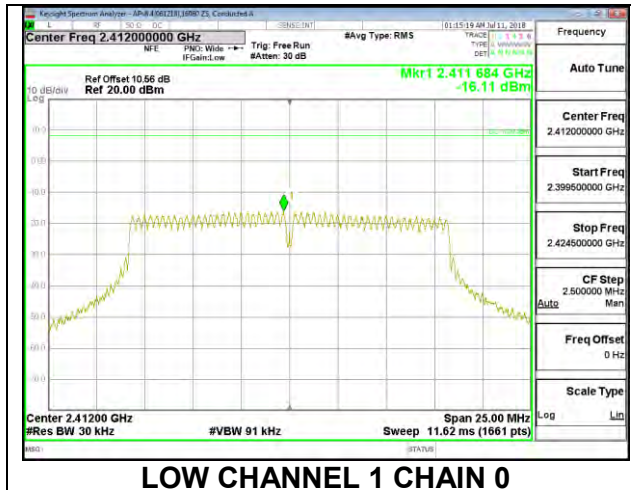

LOW CHANNEL 2

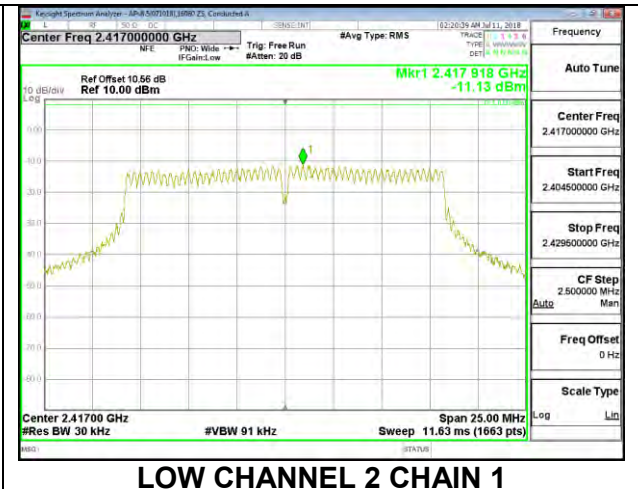
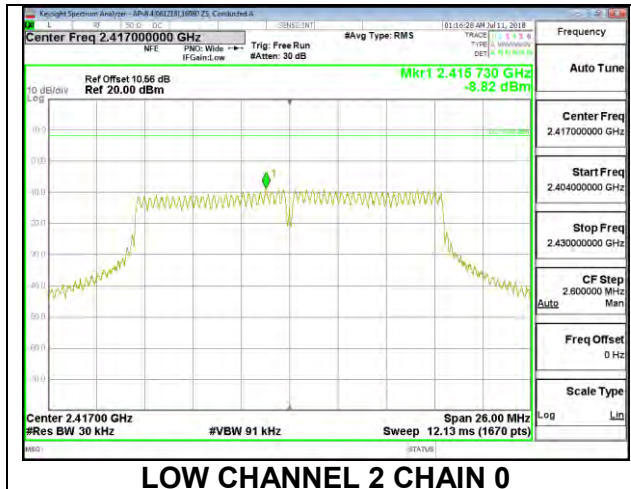

MID CHANNEL 6

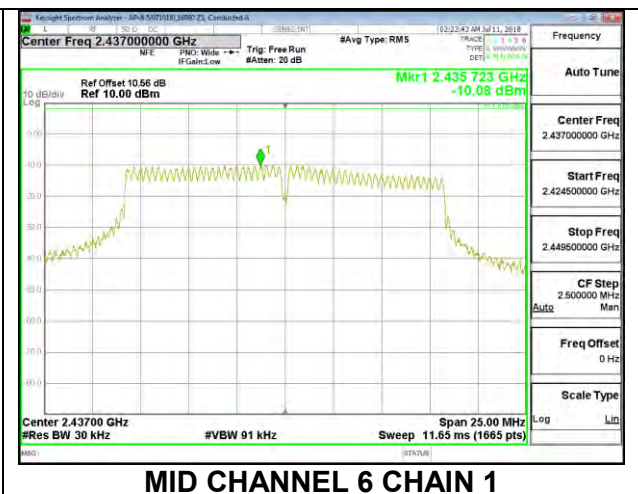
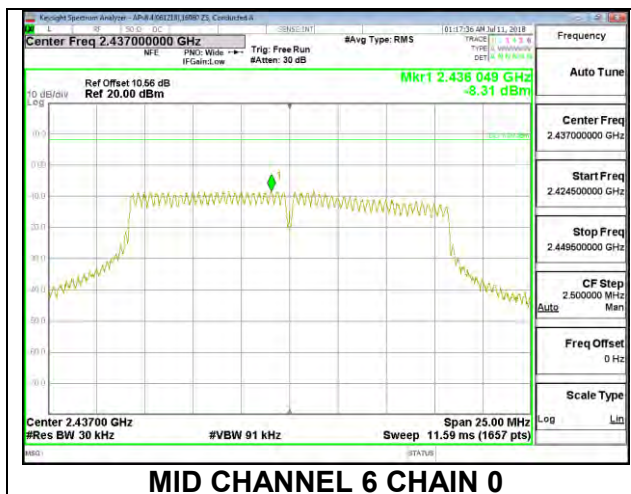

HIGH CHANNEL 11

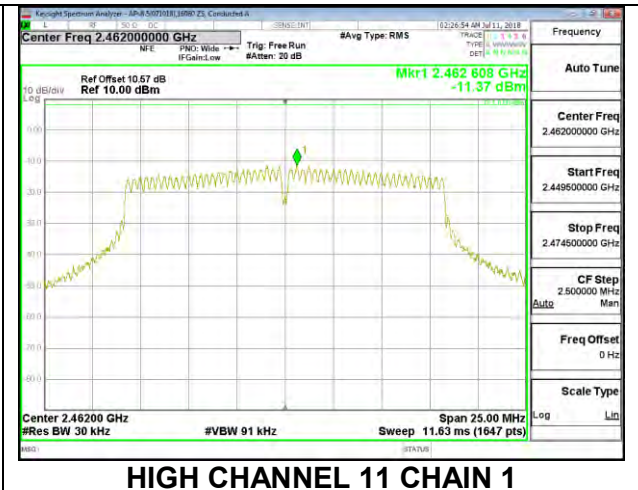
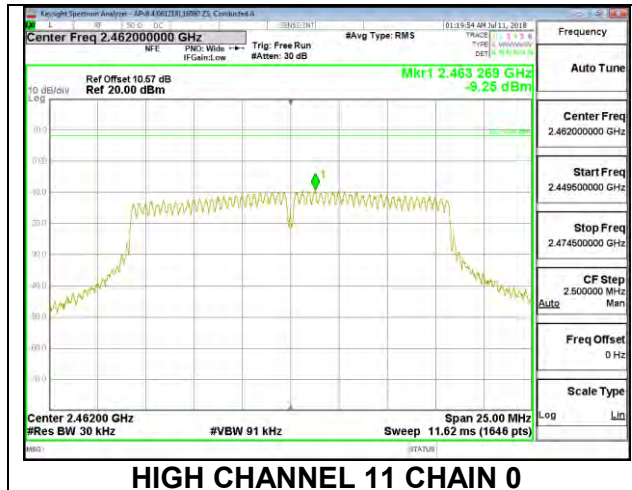

HIGH CHANNEL 12

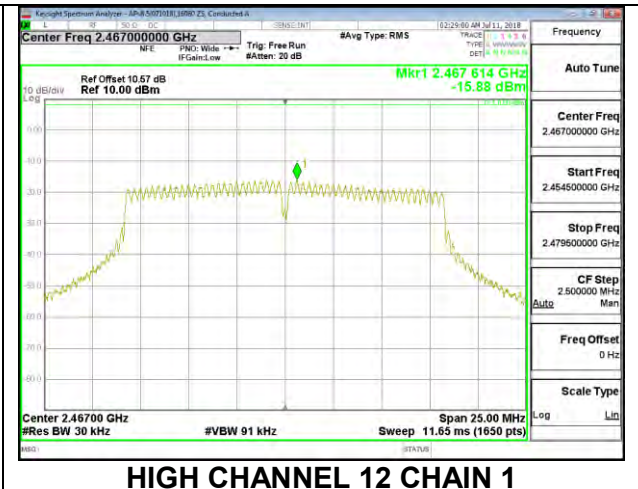
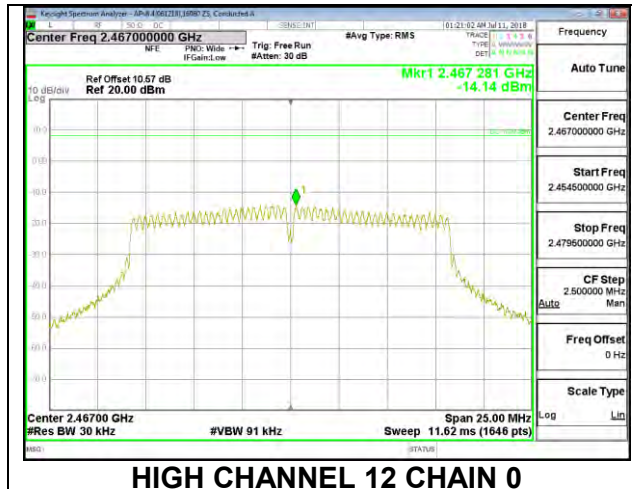

HIGH CHANNEL 13

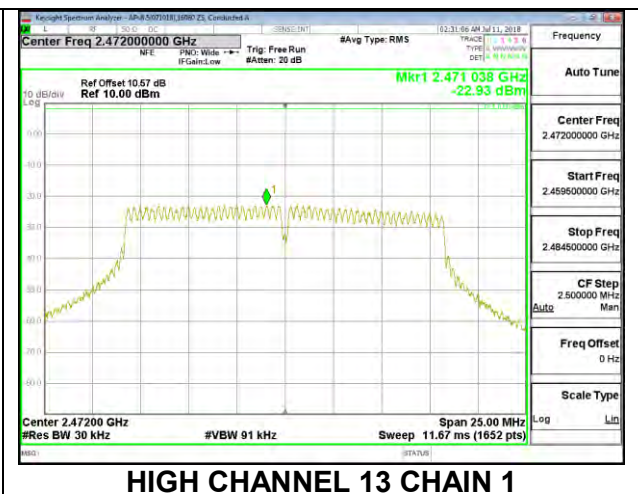
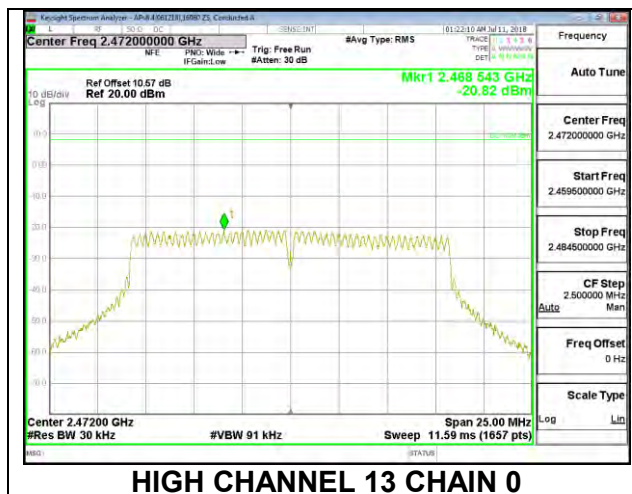

8.5.3. 802.11n HT20 MODE

2TX Antenna 1 + Antenna 2 CDD MODE

Duty Cycle CF (dB)	0.11	Included in Calculations of Corr'd PSD
---------------------------	------	-----------------------------------------------

PSD Results

Channel	Frequency (MHz)	Chain 0 Meas (dBm/ 3kHz)	Chain 1 Meas (dBm/ 3kHz)	Total Corr'd PSD (dBm/ 3kHz)	Limit (dBm/ 3kHz)	Margin (dB)
Low 1	2412	-16.38	-17.98	-13.99	8.0	-22.0
Low 2	2417	-9.14	-11.66	-7.10	8.0	-15.1
Mid 6	2437	-7.77	-9.76	-5.53	8.0	-13.5
High 11	2462	-10.30	-12.78	-8.25	8.0	-16.2
High 12	2467	-16.12	-17.84	-13.78	8.0	-21.8
High 13	2472	-22.61	-24.62	-20.38	8.0	-28.4

LOW CHANNEL 1

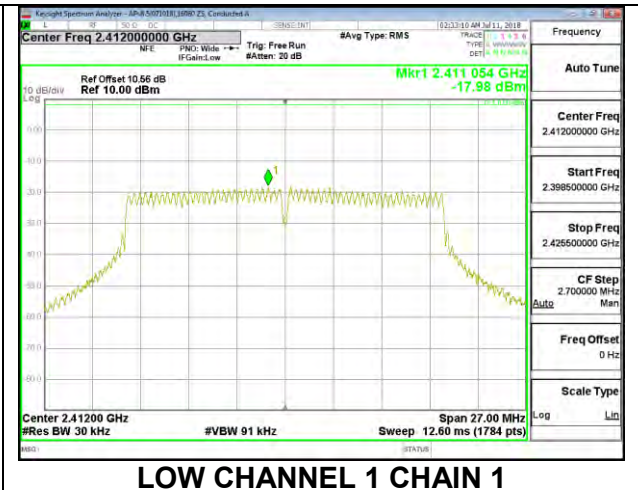
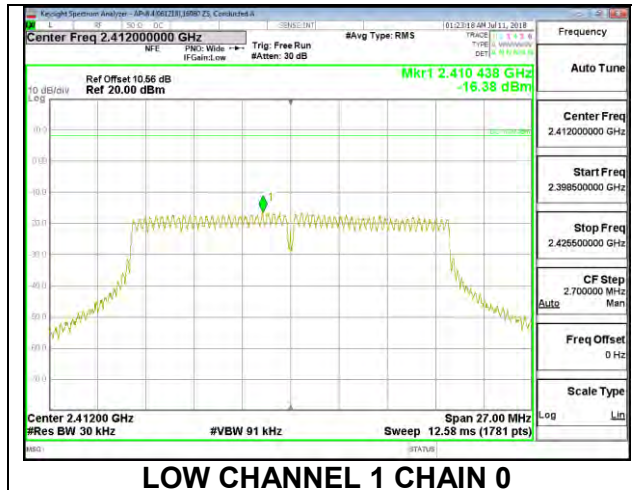

LOW CHANNEL 2

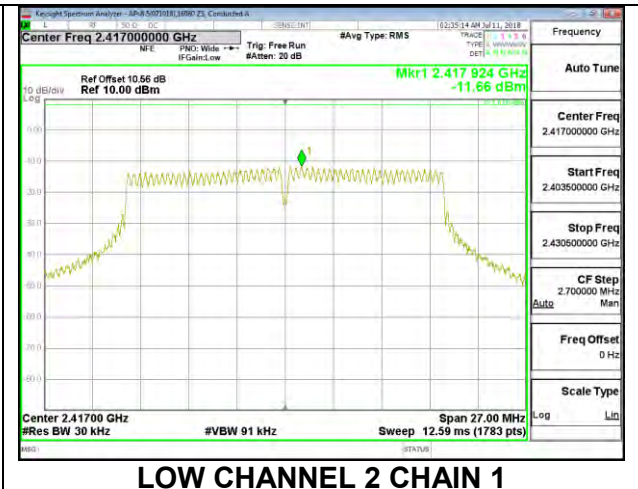
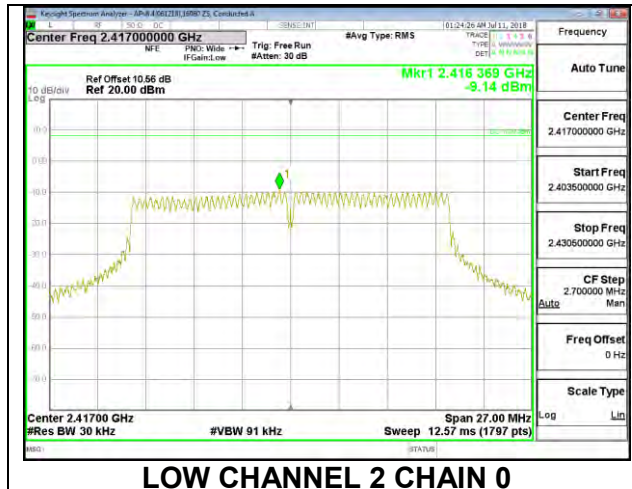

MID CHANNEL 6

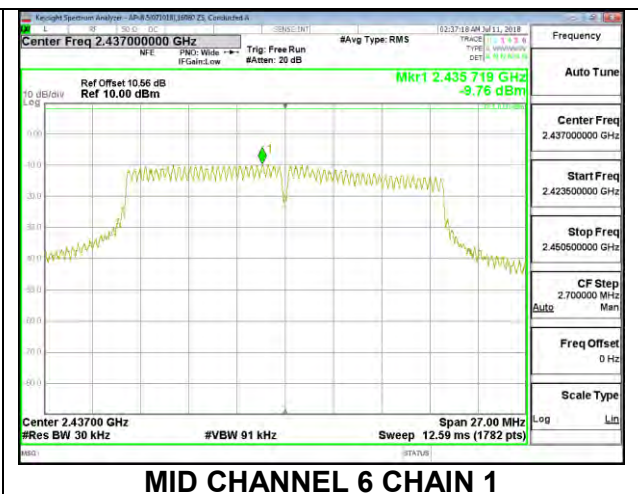
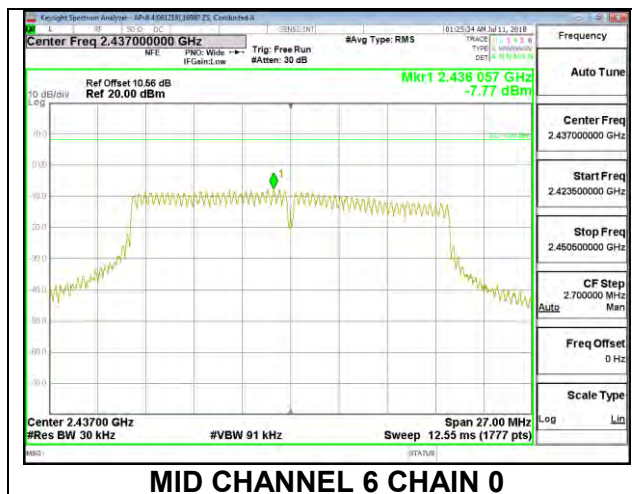

HIGH CHANNEL 11

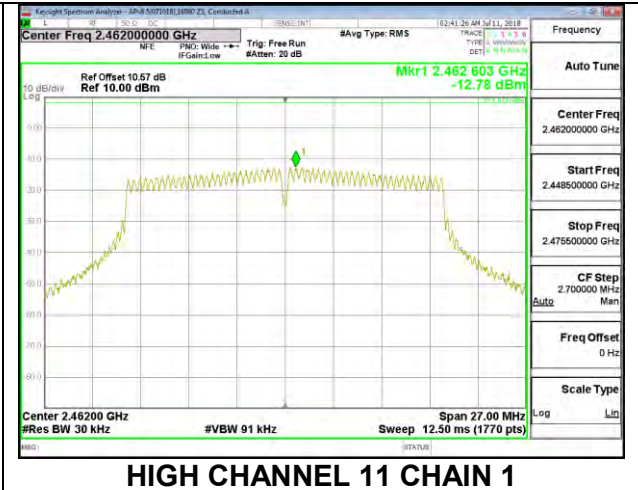
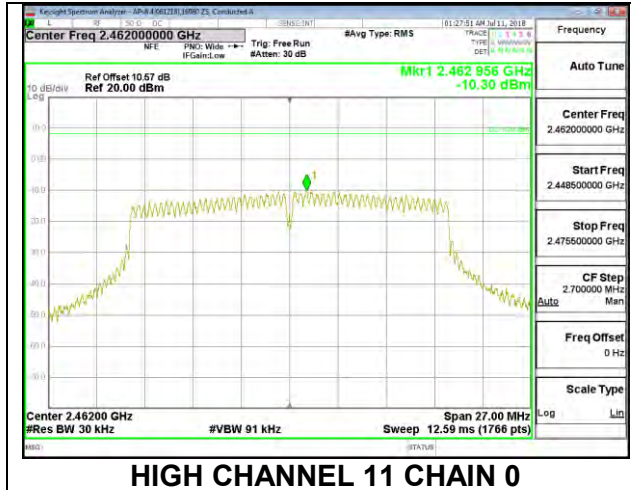

HIGH CHANNEL 12

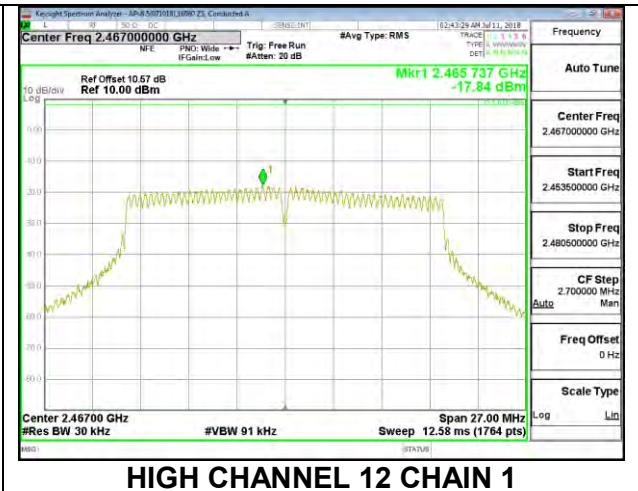
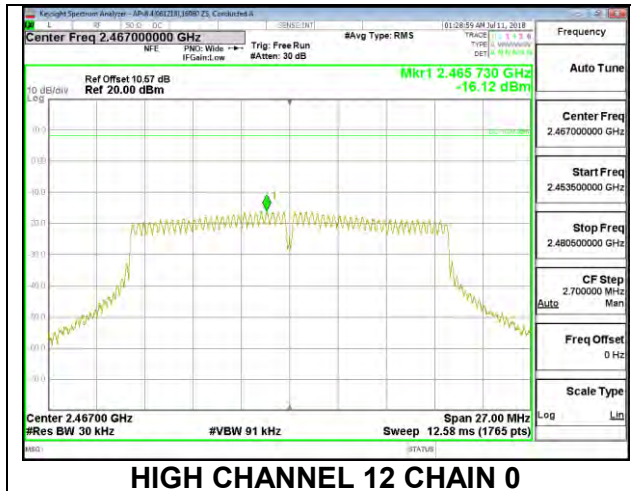

HIGH CHANNEL 13

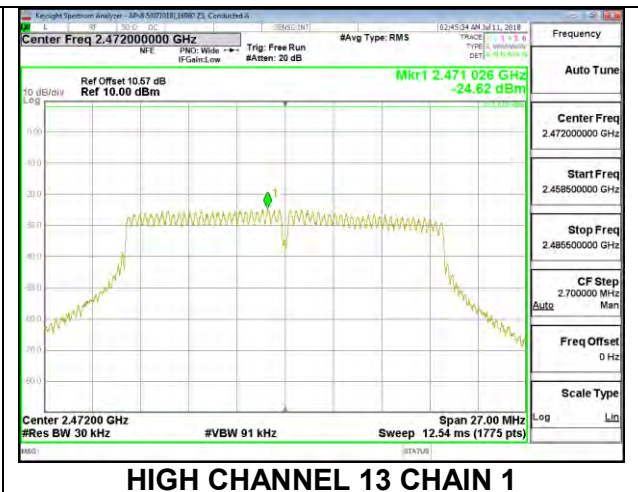
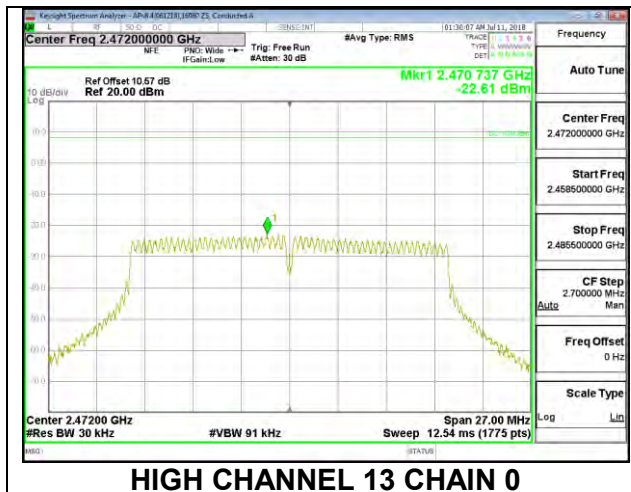

8.6. CONDUCTED SPURIOUS EMISSIONS

LIMITS

FCC §15.247 (d)

Output power was measured based on the use of peak measurement, therefore the required attenuation is 20 dB.

RESULTS

8.6.1. 802.11b MODE

2TX Antenna 1 + Antenna 2 CDD MODE

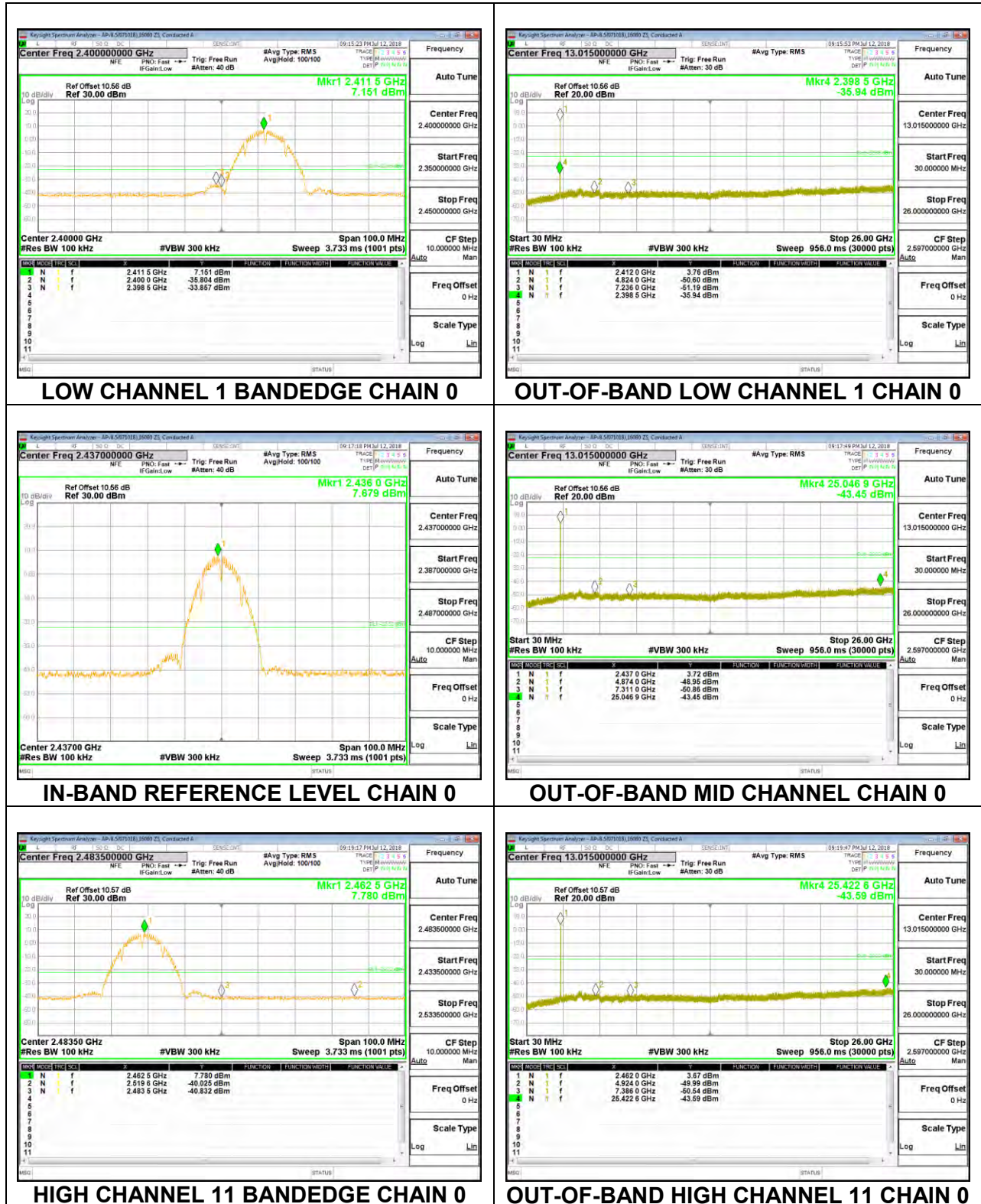

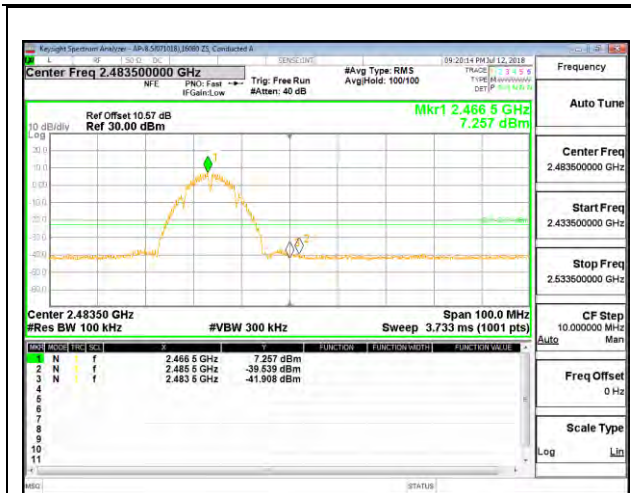

HIGH CHANNEL 12 BANDEDGE CHAIN 0

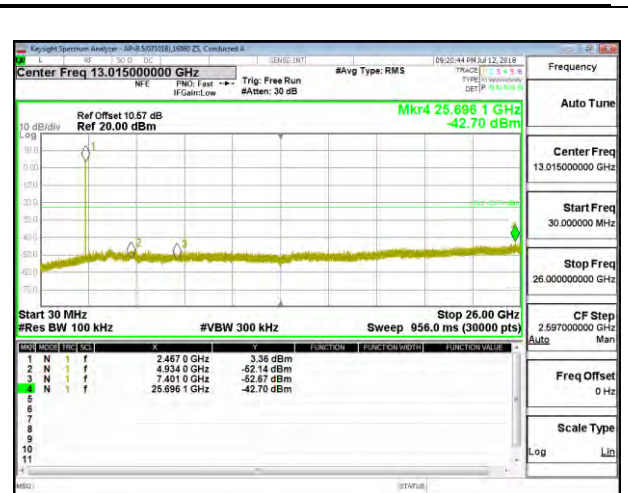

OUT-OF-BAND HIGH CHANNEL 12 CHAIN 0

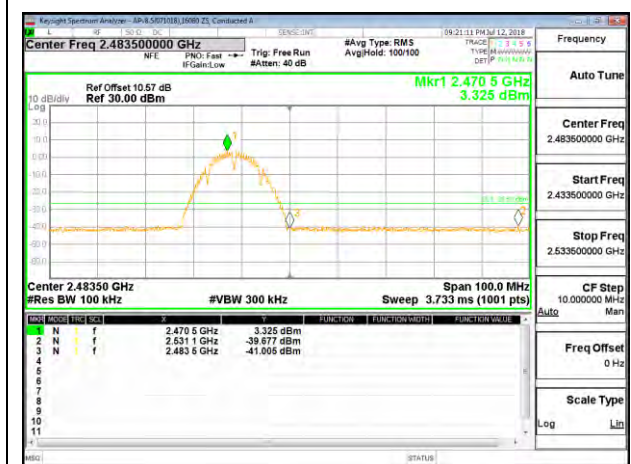

HIGH CHANNEL 13 BANDEDGE CHAIN 0



OUT-OF-BAND HIGH CHANNEL 13 CHAIN 0

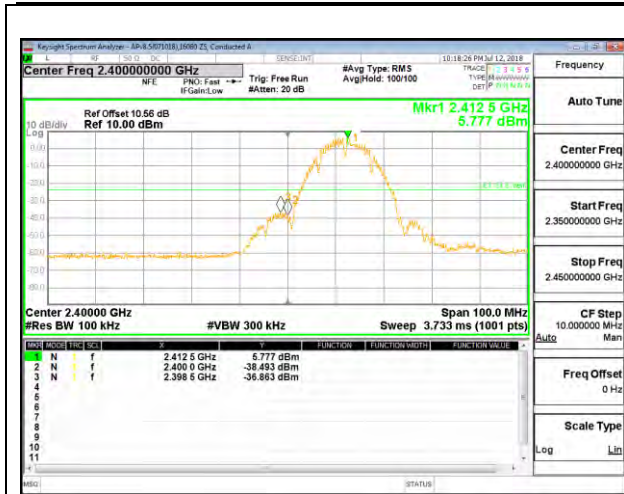

LOW CHANNEL 1 BANDEDGE CHAIN 1

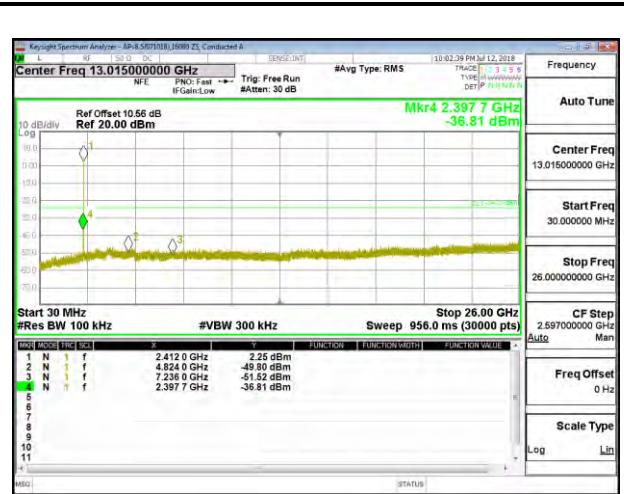

OUT-OF-BAND LOW CHANNEL 1 CHAIN 1

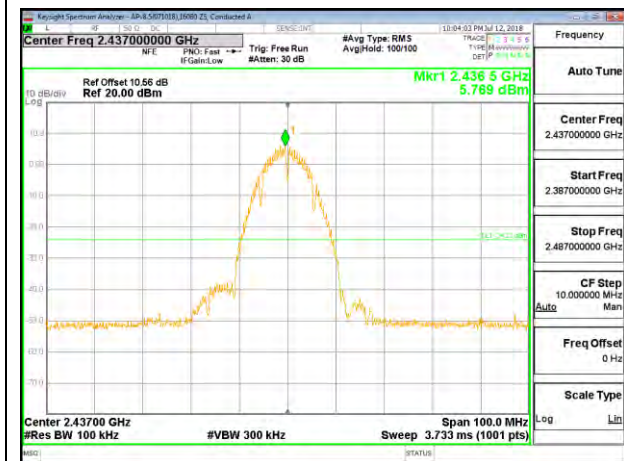

IN-BAND REFERENCE LEVEL CHAIN 1

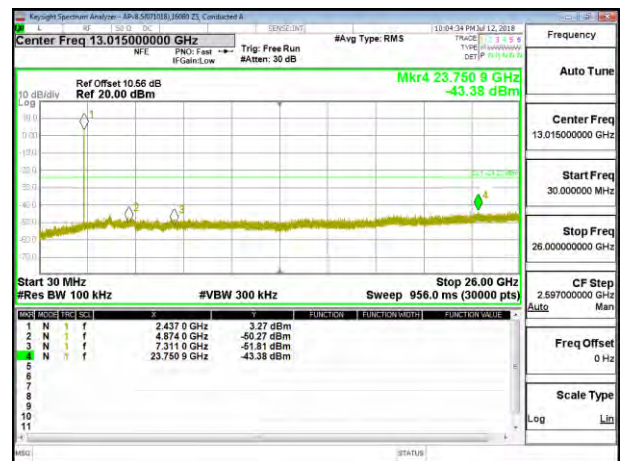

OUT-OF-BAND MID CHANNEL CHAIN 1

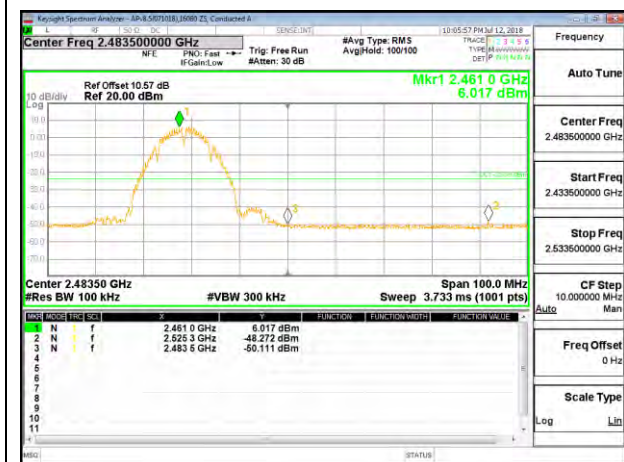

HIGH CHANNEL 11 BANDEDGE CHAIN 1

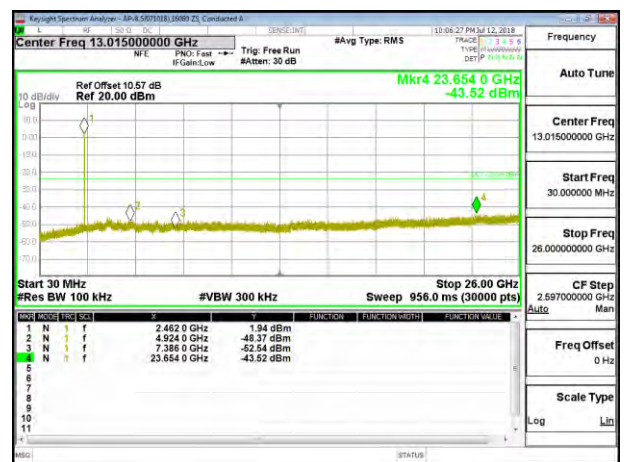

OUT-OF-BAND HIGH CHANNEL 11 CHAIN 1



HIGH CHANNEL 12 BANDEDGE CHAIN 1

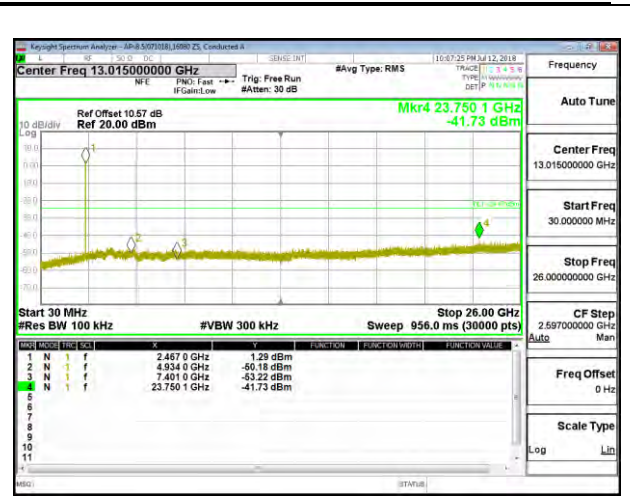

OUT-OF-BAND HIGH CHANNEL 12 CHAIN 1

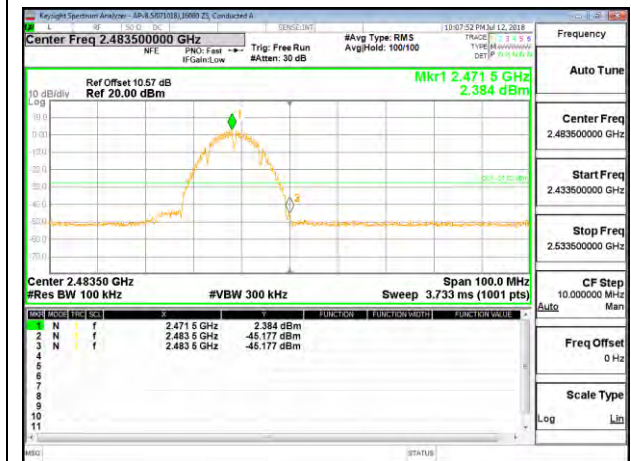

HIGH CHANNEL 13 BANDEDGE CHAIN 1

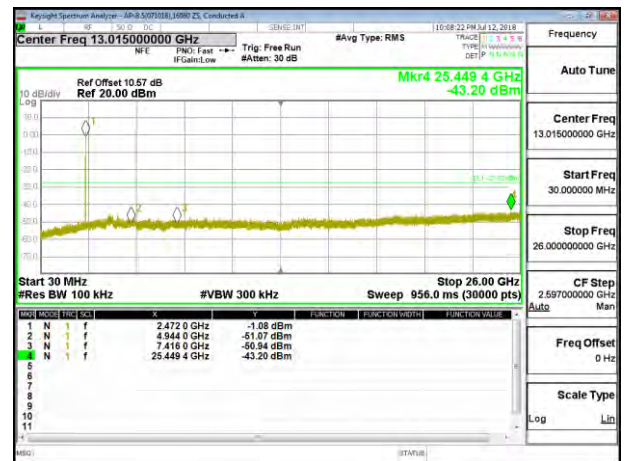

OUT-OF-BAND HIGH CHANNEL 13 CHAIN 1