



CERTIFICATION TEST REPORT

Report Number. : 12380932-E2V1

Applicant : SONY MOBILE COMMUNICATIONS, INC.
4-12-3 HIGASHI-SHINAGAWA
SHINAGAWA-KU, TOKYO, 140-0002, JAPAN

FCC ID : PY7-12644J

EUT Description : GSM/WCDMA/LTE Phone with BT, DTS/UNII a/b/g/n/ac &
NFC

Test Standard(s) : FCC 47 CFR PART 15 SUBPART C

Date Of Issue:

July 20, 2018

Prepared by:

UL Verification Services Inc.
47173 Benicia Street
Fremont, CA 94538 U.S.A.
TEL: (510) 771-1000
FAX: (510) 661-0888



NVLAP Lab code: 200065-0

REPORT REVISION HISTORY

Rev.	Issue Date	Revisions	Revised By
V1	07/20/18	Initial Issue	

TABLE OF CONTENTS

REPORT REVISION HISTORY	2
TABLE OF CONTENTS	3
1. ATTESTATION OF TEST RESULTS	5
2. TEST METHODOLOGY	6
3. FACILITIES AND ACCREDITATION	6
4. CALIBRATION AND UNCERTAINTY	7
4.1. <i>MEASURING INSTRUMENT CALIBRATION</i>	<i>7</i>
4.2. <i>SAMPLE CALCULATION</i>	<i>7</i>
4.3. <i>MEASUREMENT UNCERTAINTY.....</i>	<i>7</i>
5. EQUIPMENT UNDER TEST.....	8
5.1. <i>EUT DESCRIPTION.....</i>	<i>8</i>
5.2. <i>MAXIMUM OUTPUT POWER.....</i>	<i>8</i>
5.3. <i>DESCRIPTION OF AVAILABLE ANTENNAS.....</i>	<i>8</i>
5.4. <i>SOFTWARE AND FIRMWARE.....</i>	<i>8</i>
5.5. <i>WORST-CASE CONFIGURATION AND MODE.....</i>	<i>8</i>
5.6. <i>DESCRIPTION OF TEST SETUP.....</i>	<i>9</i>
6. TEST AND MEASUREMENT EQUIPMENT	12
7. MEASUREMENT METHODS	13
8. ANTENNA PORT TEST RESULTS	14
8.1. <i>ON TIME AND DUTY CYCLE.....</i>	<i>14</i>
8.2. <i>20 dB AND 99% BANDWIDTH</i>	<i>16</i>
8.2.1. <i>BLUETOOTH BASIC DATA RATE GFSK MODULATION</i>	<i>17</i>
8.2.2. <i>BLUETOOTH ENCHANCED DATA RATE 8PSK MODULATION</i>	<i>18</i>
8.3. <i>HOPPING FREQUENCY SEPARATION</i>	<i>19</i>
8.3.1. <i>BLUETOOTH BASIC DATA RATE GFSK MODULATION</i>	<i>20</i>
8.3.2. <i>BLUETOOTH ENCHANCED DATA RATE 8PSK MODULATION</i>	<i>21</i>
8.4. <i>NUMBER OF HOPPING CHANNELS.....</i>	<i>22</i>
8.4.1. <i>BLUETOOTH BASIC DATA RATE GFSK MODULATION</i>	<i>23</i>
8.4.2. <i>BLUETOOTH ENCHANCED DATA RATE 8PSK MODULATION</i>	<i>25</i>
8.5. <i>AVERAGE TIME OF OCCUPANCY.....</i>	<i>27</i>
8.5.1. <i>BLUETOOTH BASIC DATA RATE GFSK MODULATION</i>	<i>28</i>
8.5.2. <i>BLUETOOTH ENCHANCED DATA RATE 8PSK MODULATION</i>	<i>30</i>
8.6. <i>OUTPUT POWER.....</i>	<i>32</i>
8.6.1. <i>BLUETOOTH BASIC DATA RATE GFSK MODULATION</i>	<i>33</i>
8.6.2. <i>BLUETOOTH ENCHANCED DATA RATE 8PSK MODULATION</i>	<i>34</i>

8.7.	<i>AVERAGE POWER</i>	35
8.7.1.	BLUETOOTH BASIC DATA RATE GFSK MODULATION	36
8.7.2.	BLUETOOTH ENCHANCED DATA RATE 8PSK MODULATION	37
8.8.	<i>CONDUCTED SPURIOUS EMISSIONS</i>	38
8.8.1.	BLUETOOTH BASIC DATA RATE GFSK MODULATION	39
8.8.2.	BLUETOOTH ENCHANCED DATA RATE 8PSK MODULATION	41
9.	RADIATED TEST RESULTS	43
9.1.	<i>TRANSMITTER ABOVE 1 GHz</i>	44
9.1.1.	BLUETOOTH BASIC DATA RATE GFSK MODULATION	44
9.1.2.	BLUETOOTH ENCHANCED DATA RATE 8PSK MODULATION	54
9.2.	<i>Worst Case Below 30 MHz</i>	64
9.3.	<i>Worst Case Below 1 GHz</i>	65
9.4.	<i>Worst Case 18-26 GHz</i>	67
10.	AC POWER LINE CONDUCTED EMISSIONS	69
10.1.1.	AC Power Line Norm.....	70
11.	SETUP PHOTOS	72

1. ATTESTATION OF TEST RESULTS

COMPANY NAME: SONY MOBILE COMMUNICATIONS, INC.
4-12-3 HIGASHI-SHINAGAWA,
SHINAGAWA-KU, TOKYO, 140-0002, JAPAN

EUT DESCRIPTION: GSM/WCDMA/LTE Phone with BT, DTS/UNII a/b/g/n/ac & NFC

SERIAL NUMBER: BH93004ADB, BH93000ADB (Conducted),
BH930027D8, BH93004RD8, BH93004ND8 (Radiated)

DATE TESTED: JULY 7 – 16, 2018

APPLICABLE STANDARDS	
STANDARD	TEST RESULTS
CFR 47 Part 15 Subpart C	Complies

UL Verification Services Inc. tested the above equipment in accordance with the requirements set forth in the above standards. All indications of Pass/Fail in this report are opinions expressed by UL Verification Services Inc. based on interpretations and/or observations of test results. Measurement Uncertainties were not taken into account and are published for informational purposes only. The test results show that the equipment tested is capable of demonstrating compliance with the requirements as documented in this report.

Note: The results documented in this report apply only to the tested sample, under the conditions and modes of operation as described herein. This document may not be altered or revised in any way unless done so by UL Verification Services Inc. and all revisions are duly noted in the revisions section. Any alteration of this document not carried out by UL Verification Services Inc. will constitute fraud and shall nullify the document. This report must not be used by the client to claim product certification, approval, or endorsement by NVLAP, NIST, any agency of the Federal Government, or any agency of the U.S. government.

Approved & Released For
UL Verification Services Inc. By:

Reviewed By:



Dan Corona
CONSUMER TECHNOLOGY DIVISION
Operations Leader
UL Verification Services Inc.

Kiya Kedida
CONSUMER TECHNOLOGY DIVISION
Project Engineer
UL Verification Services Inc.

2. TEST METHODOLOGY

The tests documented in this report were performed in accordance with FCC CFR 47 Part 2, FCC CFR 47 Part 15, and ANSI C63.10-2013.

3. FACILITIES AND ACCREDITATION

The test sites and measurement facilities used to collect data are located at 47173 and 47266 Benicia Street, and 47658 Kato Road, Fremont, California, USA. Line conducted emissions are measured only at the 47173 address. The following table identifies which facilities were utilized for radiated emission measurements documented in this report. Specific facilities are also identified in the test results sections.

47173 Benicia Street	47266 Benicia Street	47658 Kato Rd.
<input checked="" type="checkbox"/> Chamber A (ISED:2324B-1)	<input type="checkbox"/> Chamber D (ISED:22541-1)	<input checked="" type="checkbox"/> Chamber K (ISED: 2324A-1)
<input checked="" type="checkbox"/> Chamber B (ISED:2324B-2)	<input type="checkbox"/> Chamber E (ISED:22541-2)	<input checked="" type="checkbox"/> Chamber L (ISED: 2324A-3)
<input type="checkbox"/> Chamber C (ISED:2324B-3)	<input type="checkbox"/> Chamber F (ISED:22541-3)	
	<input type="checkbox"/> Chamber G (ISED:22541-4)	
	<input type="checkbox"/> Chamber H (ISED:22541-5)	

The above test sites and facilities are covered under FCC Test Firm Registration # 208313. Chambers A through C are covered under ISED company address code 2324B with site numbers 2324B -1 through 2324B-3, respectively. Chambers D through H are covered under ISED company address code 22541 with site numbers 22541 -1 through 22541-5, respectively. Chambers K and L are covered under ISED company address code 2324A with site numbers 2324A-1 and 2324A-3, respectively.

UL Verification Services Inc. is accredited by NVLAP, Laboratory Code 200065-0

4. CALIBRATION AND UNCERTAINTY

4.1. MEASURING INSTRUMENT CALIBRATION

The measuring equipment utilized to perform the tests documented in this report has been calibrated in accordance with the manufacturer's recommendations, and is traceable to recognized national standards.

4.2. SAMPLE CALCULATION

Where relevant, the following sample calculation is provided:

$$\begin{aligned} \text{Field Strength (dBuV/m)} &= \text{Measured Voltage (dBuV)} + \text{Antenna Factor (dB/m)} + \\ &\text{Cable Loss (dB)} - \text{Preamp Gain (dB)} \\ 36.5 \text{ dBuV} + 18.7 \text{ dB/m} + 0.6 \text{ dB} - 26.9 \text{ dB} &= 28.9 \text{ dBuV/m} \end{aligned}$$

4.3. MEASUREMENT UNCERTAINTY

Where relevant, the following measurement uncertainty levels have been estimated for tests performed on the apparatus:

PARAMETER	UNCERTAINTY
Worst Case Conducted Disturbance, 9KHz to 0.15 MHz	3.84 dB
Worst Case Conducted Disturbance, 0.15 to 30 MHz	3.65 dB
Worst Case Radiated Disturbance, 9KHz to 30 MHz	3.15 dB
Worst Case Radiated Disturbance, 30 to 1000 MHz	5.36 dB
Worst Case Radiated Disturbance, 1000 to 18000 MHz	4.32 dB
Worst Case Radiated Disturbance, 18000 to 26000 MHz	4.45 dB
Worst Case Radiated Disturbance, 26000 to 40000 MHz	5.24 dB

Uncertainty figures are valid to a confidence level of 95%.

5. EQUIPMENT UNDER TEST

5.1. EUT DESCRIPTION

The EUT is a GSM/WCDMA/LTE Phone with BT, DTS/UNII a/b/g/n/ac & NFC.

5.2. MAXIMUM OUTPUT POWER

The transmitter has a maximum peak conducted output power as follows:

Frequency Range (MHz)	Mode	Output Power (dBm)	Output Power (mW)
2402 - 2480	Basic GFSK	11.41	13.84
2402 - 2480	Enhanced 8PSK	9.17	8.26

Note: GFSK, DQPSK, 8PSK average Power are all investigated, The GFSK & 8PSK Power are the worst case. Testing is based on these modes to showing compliance.

5.3. DESCRIPTION OF AVAILABLE ANTENNAS

The radio utilizes a loop antenna for chain 0 with maximum gain of -1.5dBi.

5.4. SOFTWARE AND FIRMWARE

The firmware installed in the EUT during testing was s_atp_0_00436_A_12_16.
The test utility software used during testing was Tera Term Ver 4.79

5.5. WORST-CASE CONFIGURATION AND MODE

Radiated emissions below 1GHz, above 18GHz, and power line conducted emission were performed with the EUT set to transmit at the channel with highest output power as worst-case scenario.

Band edge and radiated emissions between 1GHz and 18GHz were performed with the EUT set to transmit at the highest power on low, middle and high channels.

The fundamental of the EUT was investigated in three orthogonal orientations X,Y,Z, it was determined that X orientation was worst-case orientation; therefore, all final radiated testing was performed with the EUT in X orientation.

Worst-case data rates as provided by the client were:

GFSK mode: DH5
8PSK mode: 3-DH5

5.6. DESCRIPTION OF TEST SETUP

SUPPORT EQUIPMENT

Support Equipment List				
Description	Manufacturer	Model	Serial Number	FCC ID
Laptop	Lenovo	20B7S0A200	PC015REW	N/A
Desktop	Lenovo	ThinkCentre	MJ00QA59	N/A
AC Adapter	SONY	UCH20	3416W45305784	N/A
DC Power Supply	Ametek	XT 15-4	T463	N/A

I/O CABLES (CONDUCTED TEST)

I/O Cable List						
Cable No	Port	# of identical ports	Connector Type	Cable Type	Cable Length (m)	Remarks
1	Antenna	1	RF	Shielded	0.2	To spectrum Analyzer
2	USB	1	USB Type C	Shielded	1	N/A
3	DC	1	DC	Shielded	0.3	N/A

I/O CABLES (RADIATED AND CONDUCTED EMISSIONS)

I/O Cable List						
Cable No	Port	# of identical ports	Connector Type	Cable Type	Cable Length (m)	Remarks
1	USB	1	USB Type C	Shielded	3	N/A

TEST SETUP

The EUT is connected to a test laptop during the tests. Test software exercised the radio card.

CONDCUTED TEST SETUP DIAGRAM

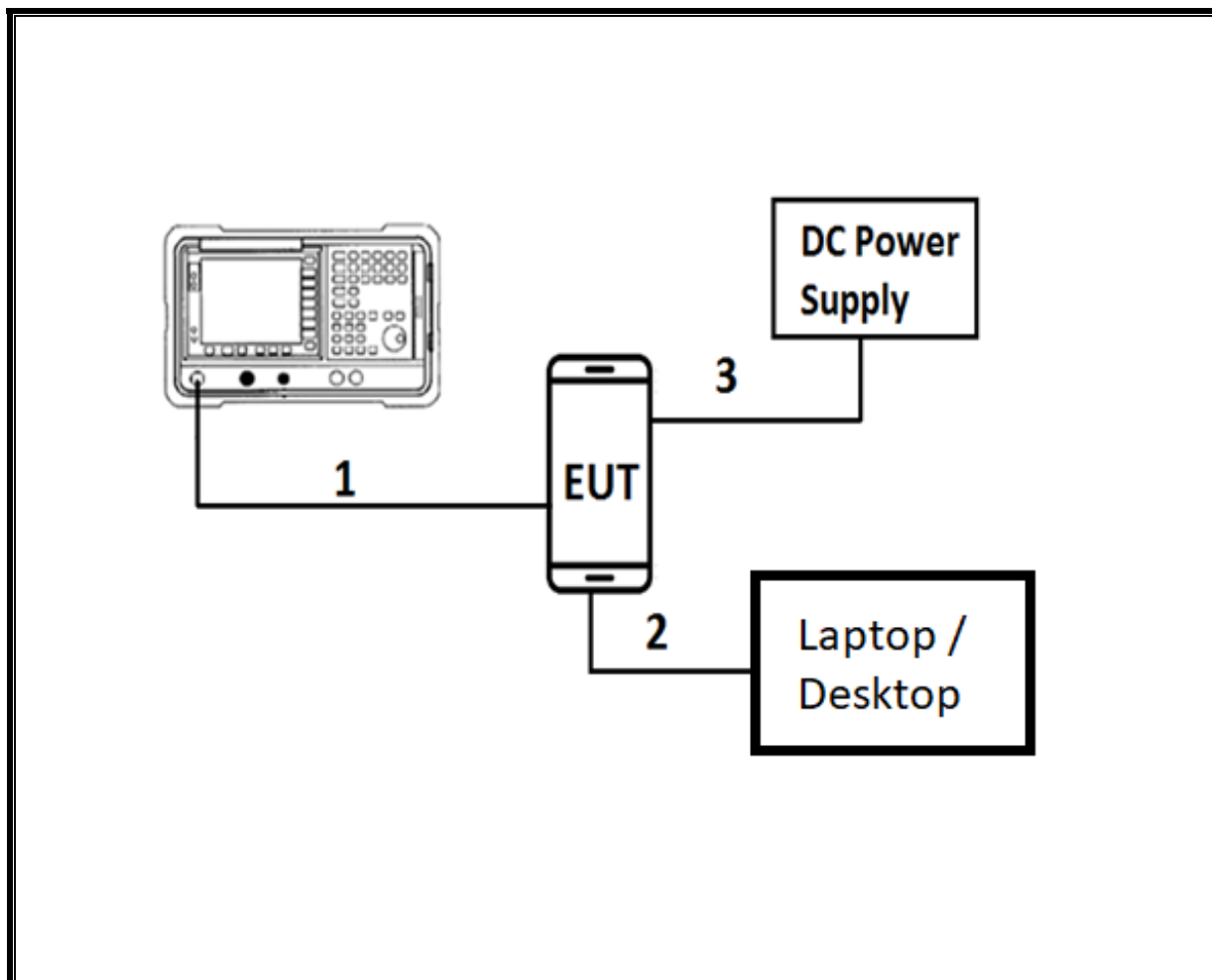

TEST SETUP

For conducted tests: the EUT was connected to a host laptop via an USB cable for parameter setting purpose such as channel, output power...etc. The test software exercises the radio.

RADIATED AND AC LINE CONDUCTED EMISSIONS SETUP DIAGRAM

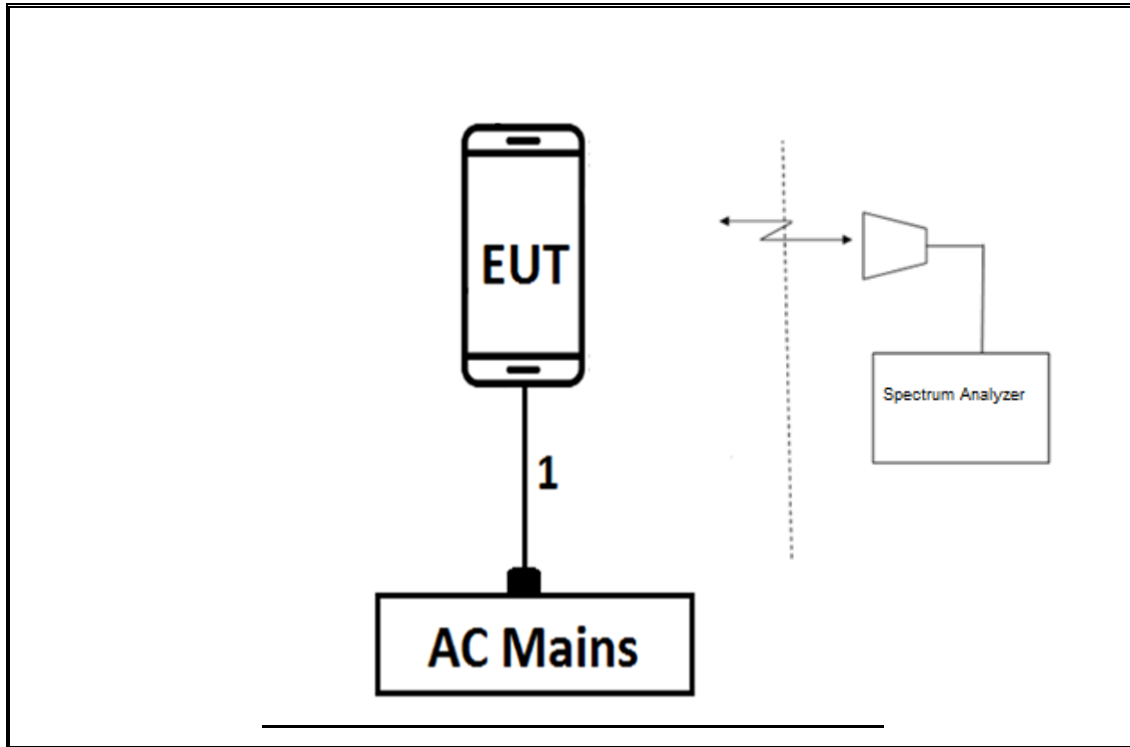

TEST SETUP

For radiated tests: All support equipment were removed after the EUT programmed. The test software exercises the radio.

6. TEST AND MEASUREMENT EQUIPMENT

The following test and measurement equipment was utilized for the tests documented in this report:

TEST EQUIPMENT LIST				
Description	Manufacturer	Model	ID Num	Cal Due
Amplifier, 100kHz to 1GHz, 32dB	Hewlet Packard	8447D	T15	08/14/2018
Antenna, Broadband Hybrid, 30MHz to 2000MHz	Sunol Sciences Corp.	JB1	T130	10/16/2018
Antenna, Horn 1-18GHz	ETS-Lindgren	3117	T344	04/30/2019
Antenna, Horn 1-18GHz	ETS-Lindgren	3117	T345	04/25/2019
Amplifier, 1 to 18GHz, 35dB	AMPLICAL	AMP1G18-35	T1569	06/03/2019
RF Amplifier	MITEQ	AFS42-00101800-25-S-42	T1165	04/23/2019
Amplifier, 1 to 7.0GHz, 20.0dB Gain minimum, 6dB NF	AMPLICAL	AMP1G7-20-27	T1563	06/03/2019
Amplifier, 1 to 8GHz, 35dB	Miteq Inc.	AMF-4D-01000800-30-29P	T1573	04/03/2019
EMI TEST RECEIVER	Rohde & Schwarz	ESW44	PRE0179367	04/25/2019
Spectrum Analyzer, PXA, 3Hz to 44GHz	Agilent (Keysight) Technologies	N9030A	T1450	02/05/2019
Spectrum Analyzer, PXA, 3Hz to 44GHz	Agilent (Keysight) Technologies	N9030A	T1113	12/21/2018
Spectrum Analyzer, PSA, 3Hz to 44GHz	Agilent (Keysight) Technologies	N9030A	T1466	04/16/2019
Spectrum Analyzer, PSA, 3Hz to 44GHz	Agilent (Keysight) Technologies	N9030A	T1454	01/08/2019
Power Meter, P-series single channel	Agilent (Keysight) Technologies	N1911A	T1271	07/17/2018
Power Sensor, P-series, 50MHz to 18GHz, Wideband	Agilent (Keysight) Technologies	N1921A	T1225	04/10/2019
Filter, HPF 3.0GHz	MICRO-TRONICS	HPM17543	T486	04/03/2019
Filter, HPF 3.0GHz	MICRO-TRONICS	HPM17543	T897	06/03/2019
Antenna, Active Loop 9kHz-30MHz	Com-Power Corp.	AL-130R	T1866	10/10/2018
18 - 26.5 GHz Horn Antenna	Seavey Division	MWH-1826/B	T89	01/18/2019
Pre-Amp 1-26.5 GHz	Agilent	8449B	T404	03/09/2019
EMI Reciever	Rohde & Schwarz	ESR	T1436	02/21/2019
L.I.S.N.	FCC INC.	FCC LISN 50/250	T1310	06/15/2019
L.I.S.N.	FCC INC.	FCC LISN 50/250	T24	03/06/2019
Thermometer - Digital	Control Company	14-650-118	PRE0177862	02/22/2019

Test Software List			
Description	Manufacturer	Model	Version
Radiated Software	UL	UL EMC	Ver 9.5, June 22, 2018
Antenna Port Software	UL	UL RF	Ver 8.4, June 12, 2018

7. MEASUREMENT METHODS

On Time and Duty Cycle: ANSI C63.10-2013 Section 11.6

Occupied BW (20dB): ANSI C63.10-2013 Section 6.9.2

Occupied BW (99%): ANSI C63.10-2013 Section 6.9.3

Carrier Frequency Separation: ANSI C63.10-2013 Section 7.8.2

Number of Hopping Frequencies: ANSI C63.10-2013 Section 7.8.3

Time of Occupancy (Dwell Time): ANSI C63.10-2013 Section 7.8.4

Peak Output Power: ANSI C63.10-2013 Section 7.8.5

Conducted Spurious Emissions: ANSI C63.10-2013 Section 7.8.8

Conducted Band-Edge: ANSI C63.10-2013 Section 6.10.4

Radiated Spurious Emissions 30-1000MHz: ANSI C63.10-2013 Section 6.3 and 6.5

Radiated Spurious Emissions above 1GHz: ANSI C63.10-2013 Section 6.3 and 6.6

Radiated Band-edge: ANSI C63.10-2013 Section 6.10.5

AC Power-line conducted emissions: ANSI C63.10-2013, Section 6.2.

8. ANTENNA PORT TEST RESULTS

8.1. ON TIME AND DUTY CYCLE

LIMITS

None; for reporting purposes only.

PROCEDURE

KDB 789033 Zero-Span Spectrum Analyzer Method.

ON TIME AND DUTY CYCLE RESULTS

Mode	ON Time B (msec)	Period (msec)	Duty Cycle x (linear)	Duty Cycle (%)	Duty Cycle Correction Factor (dB)	1/T Minimum VBW (kHz)
Bluetooth GFSK	2.901	3.749	0.774	77.4%	1.11	0.345
Bluetooth 8PSK	2.903	3.748	0.775	77.5%	1.11	0.344

DUTY CYCLE PLOTS

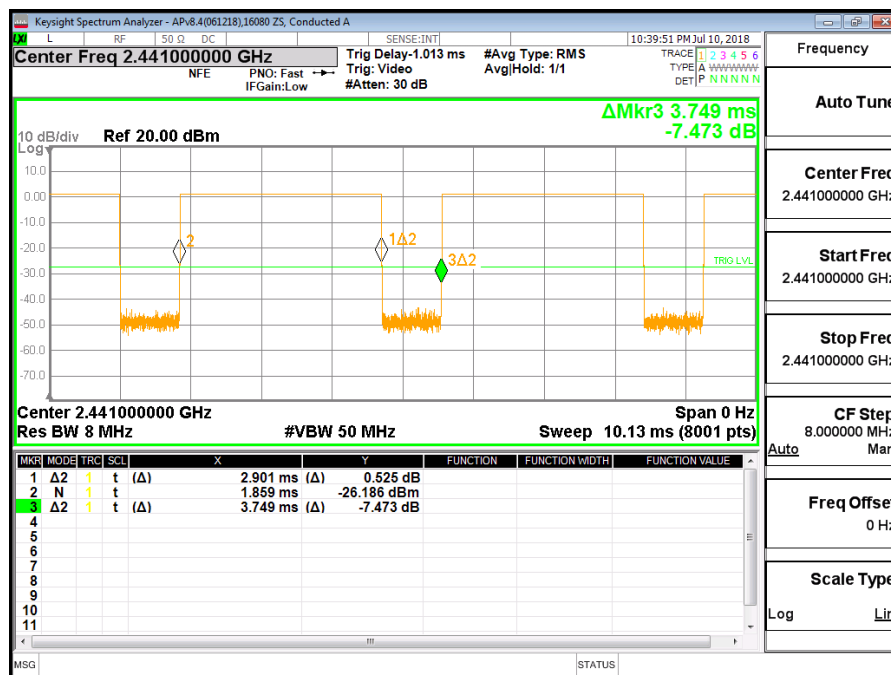

BLUETOOTH GFSK

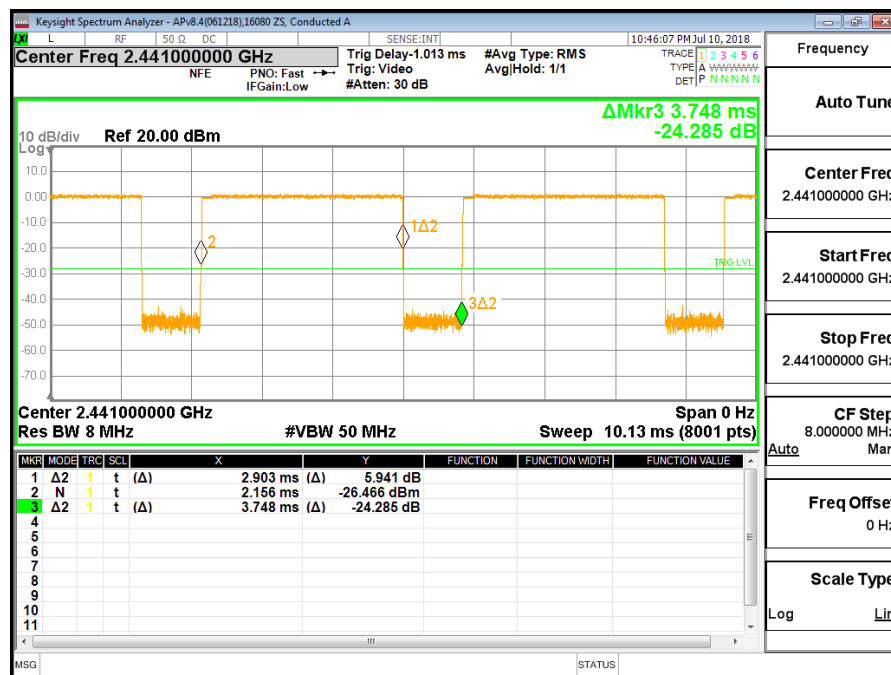

BLUETOOTH 8PSK

8.2. 20 dB AND 99% BANDWIDTH

LIMITS

None; for reporting purposes only.

TEST PROCEDURE

The transmitter output is connected to a spectrum analyzer. The RBW is set to $\geq 1\%$ of the 20 dB bandwidth. The VBW is set to \geq RBW. The sweep time is coupled.

RESULTS

8.2.1. BLUETOOTH BASIC DATA RATE GFSK MODULATION

Channel	Frequency (MHz)	20dB Bandwidth (MHz)	99% Bandwidth (MHz)
Low	2402	0.934	0.861
Mid	2441	0.941	0.872
High	2480	0.916	0.848

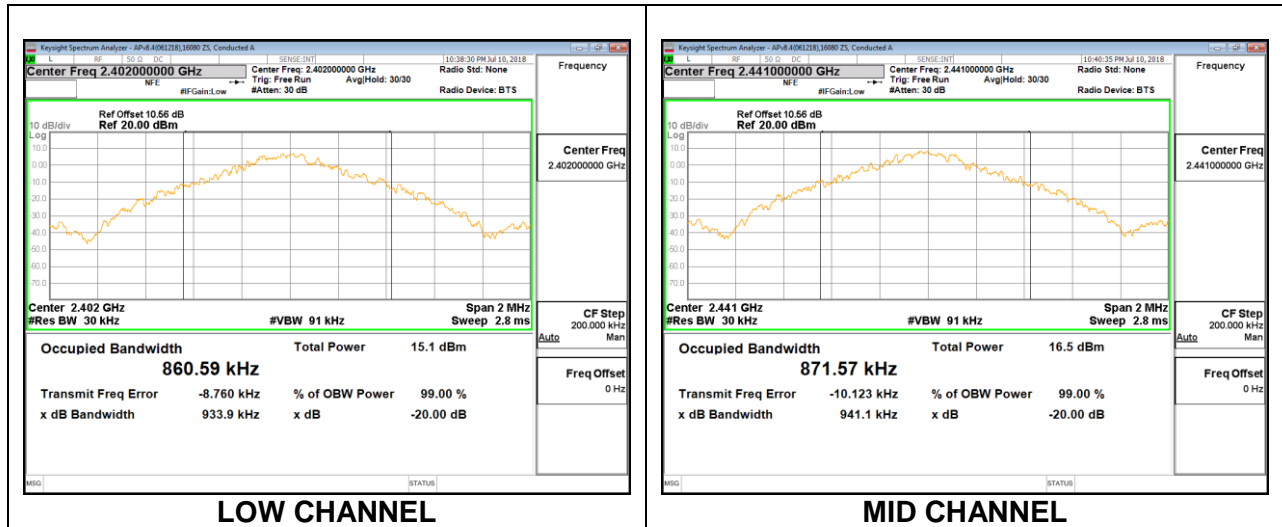

LOW CHANNEL

MID CHANNEL

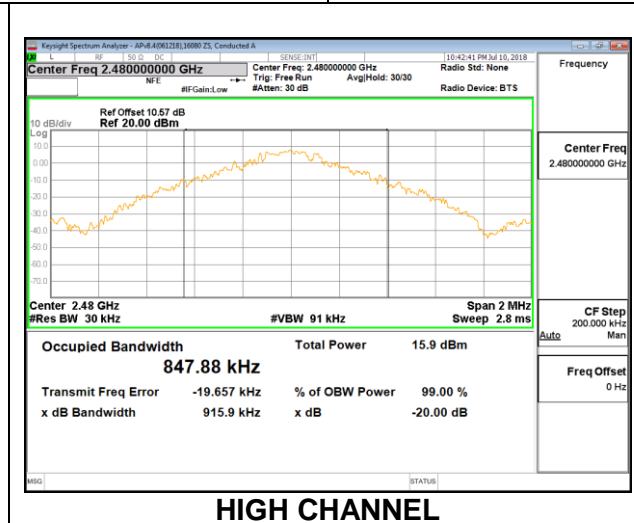

HIGH CHANNEL

8.2.2. BLUETOOTH ENCHANCED DATA RATE 8PSK MODULATION

Channel	Frequency (MHz)	20dB Bandwidth (MHz)	99% Bandwidth (MHz)
Low	2402	1.332	1.2016
Mid	2441	1.277	1.1881
High	2480	1.320	1.2058

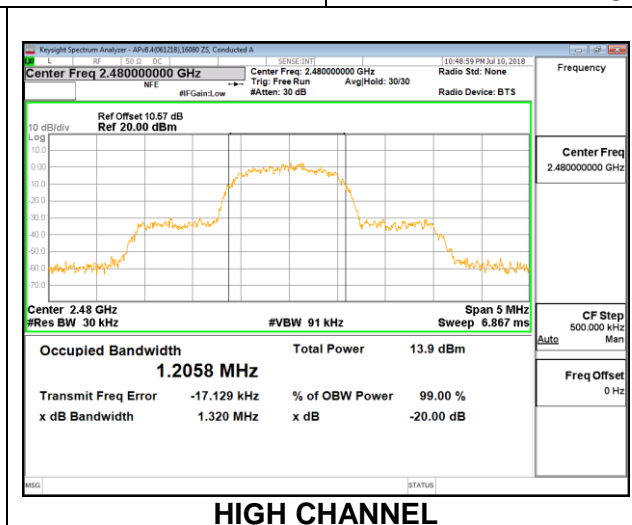
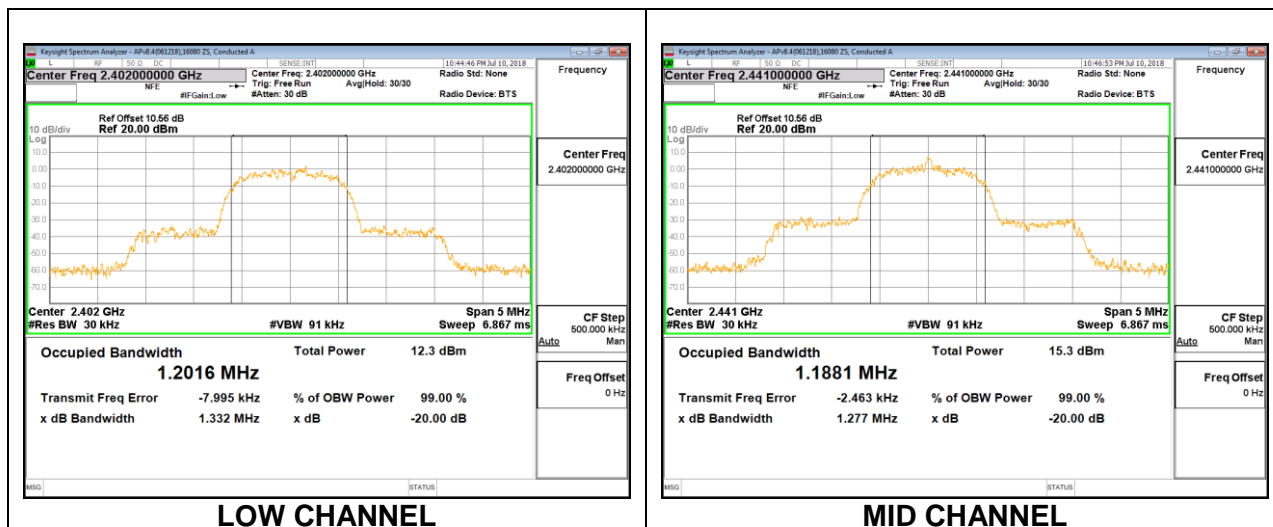

8.3. HOPPING FREQUENCY SEPARATION

LIMITS

FCC §15.247 (a) (1)

Frequency hopping systems shall have hopping channel carrier frequencies separated by a minimum of 25 kHz or the 20 dB bandwidth of the hopping channel, whichever is greater.

Alternatively, frequency hopping systems operating in the 2400-2483.5 MHz band may have hopping channel carrier frequencies that are separated by 25 kHz or two-thirds of the 20 dB bandwidth of the hopping channel, whichever is greater, provided the systems operate with an output power no greater than 125 mW.

TEST PROCEDURE

The transmitter output is connected to a spectrum analyzer. The RBW is set to 300 kHz and the VBW is set to 300 kHz. The sweep time is coupled.

RESULTS

8.3.1. BLUETOOTH BASIC DATA RATE GFSK MODULATION

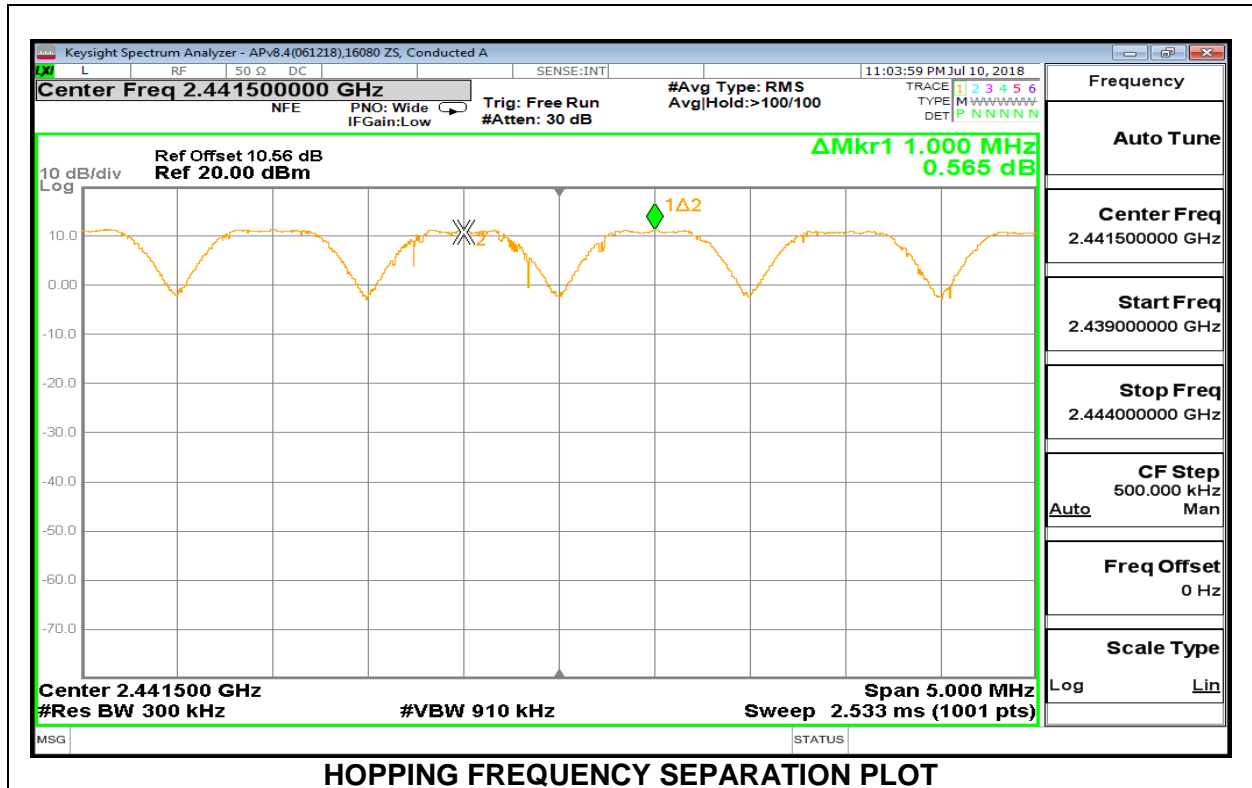

8.3.2. BLUETOOTH ENCHANCED DATA RATE 8PSK MODULATION

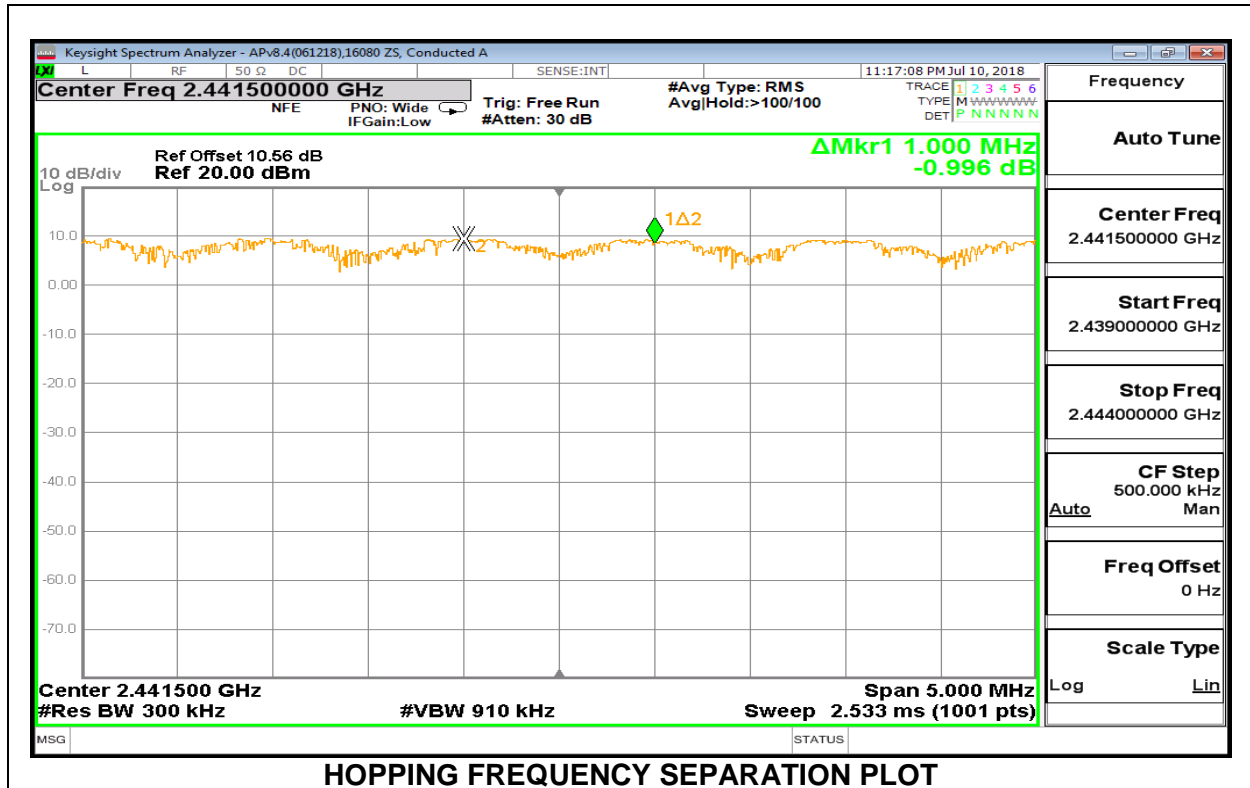

8.4. NUMBER OF HOPPING CHANNELS

LIMITS

FCC §15.247 (a) (1) (iii)

Frequency hopping systems in the 2400 – 2483.5 MHz band shall use at least 15 non-overlapping channels.

TEST PROCEDURE

The transmitter output is connected to a spectrum analyzer. The span is set to cover the entire authorized band, in either a single sweep or in multiple contiguous sweeps. The RBW is set to a maximum of 1 % of the span. The analyzer is set to Max Hold.

RESULTS

Normal Mode: 79 Channels Observed

8.4.1. BLUETOOTH BASIC DATA RATE GFSK MODULATION

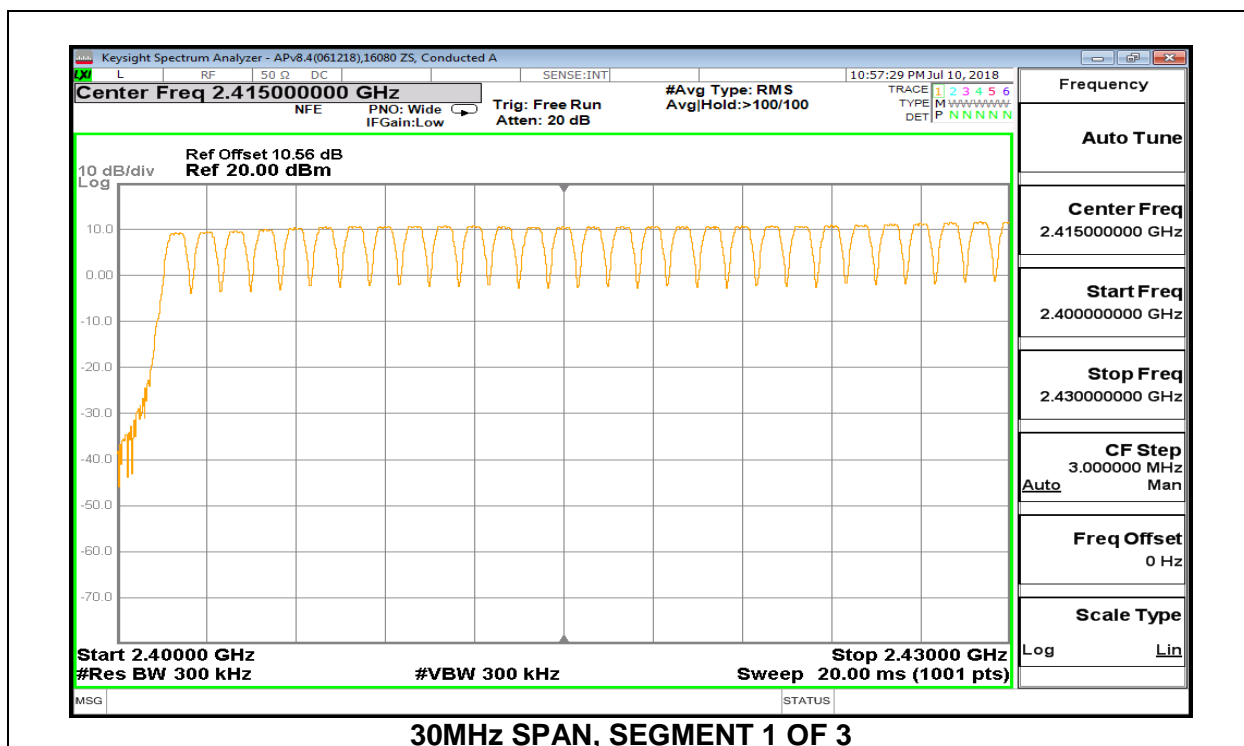
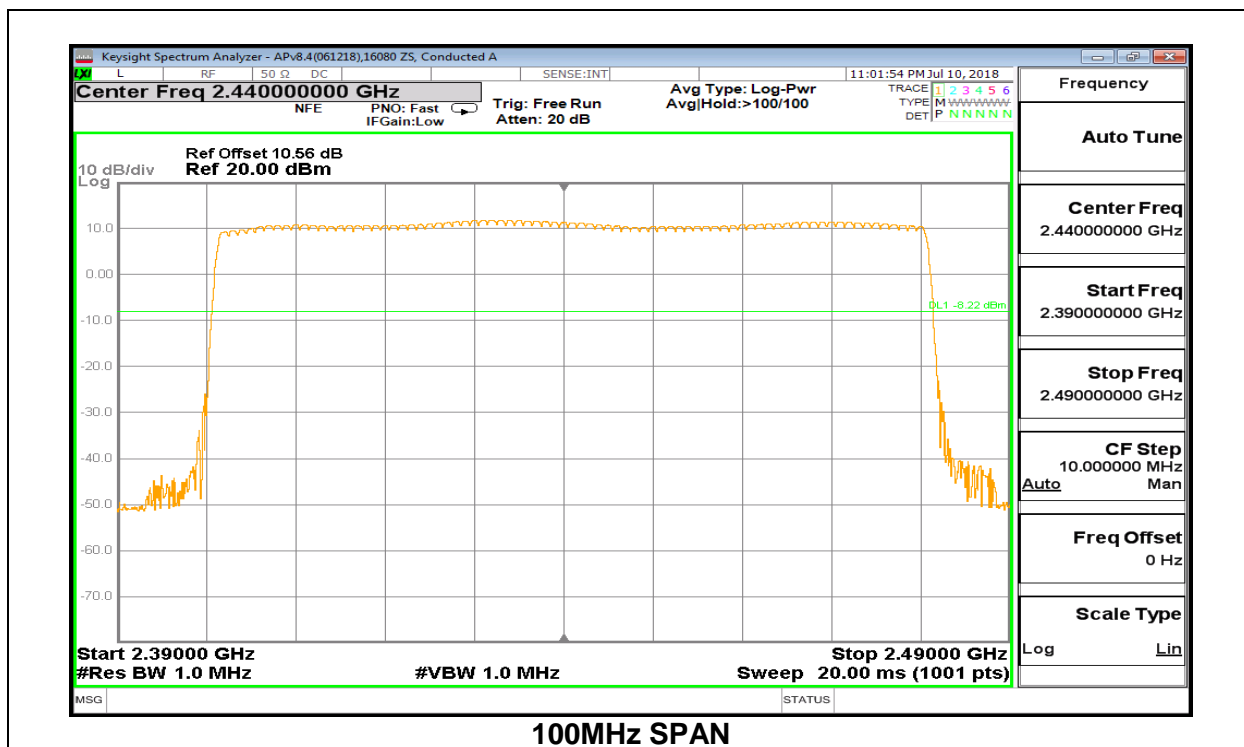

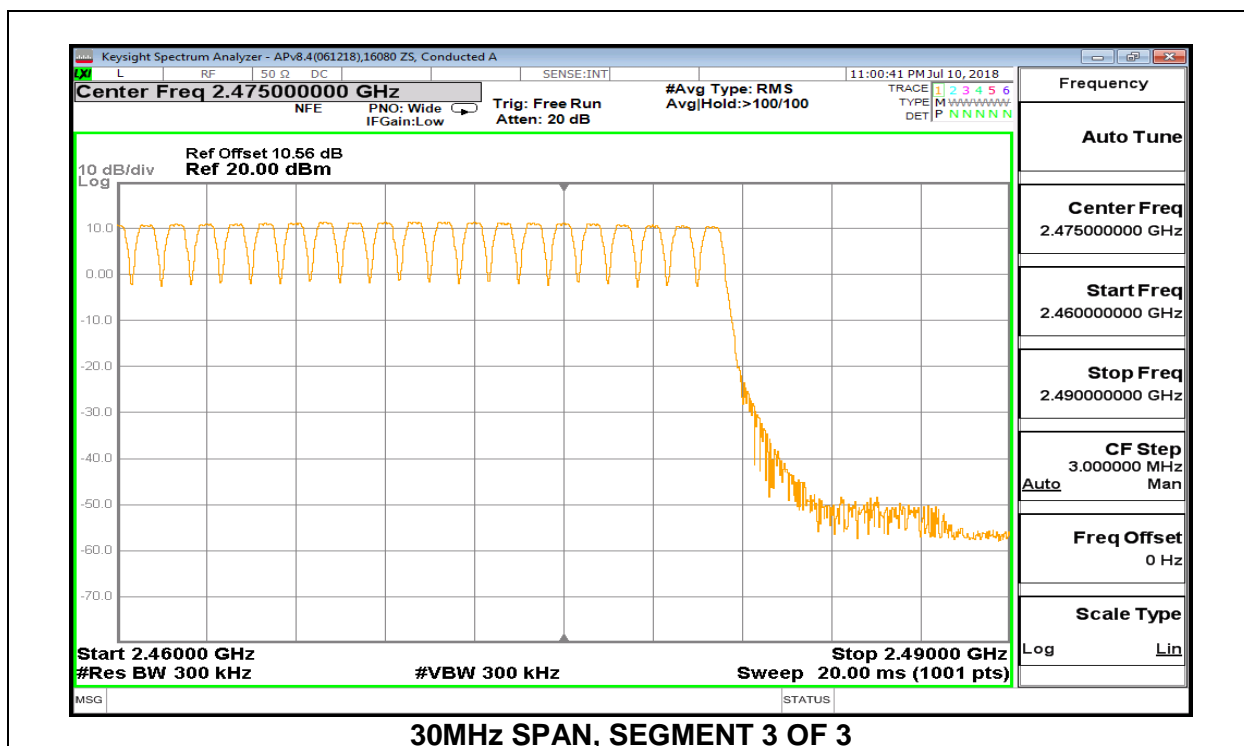
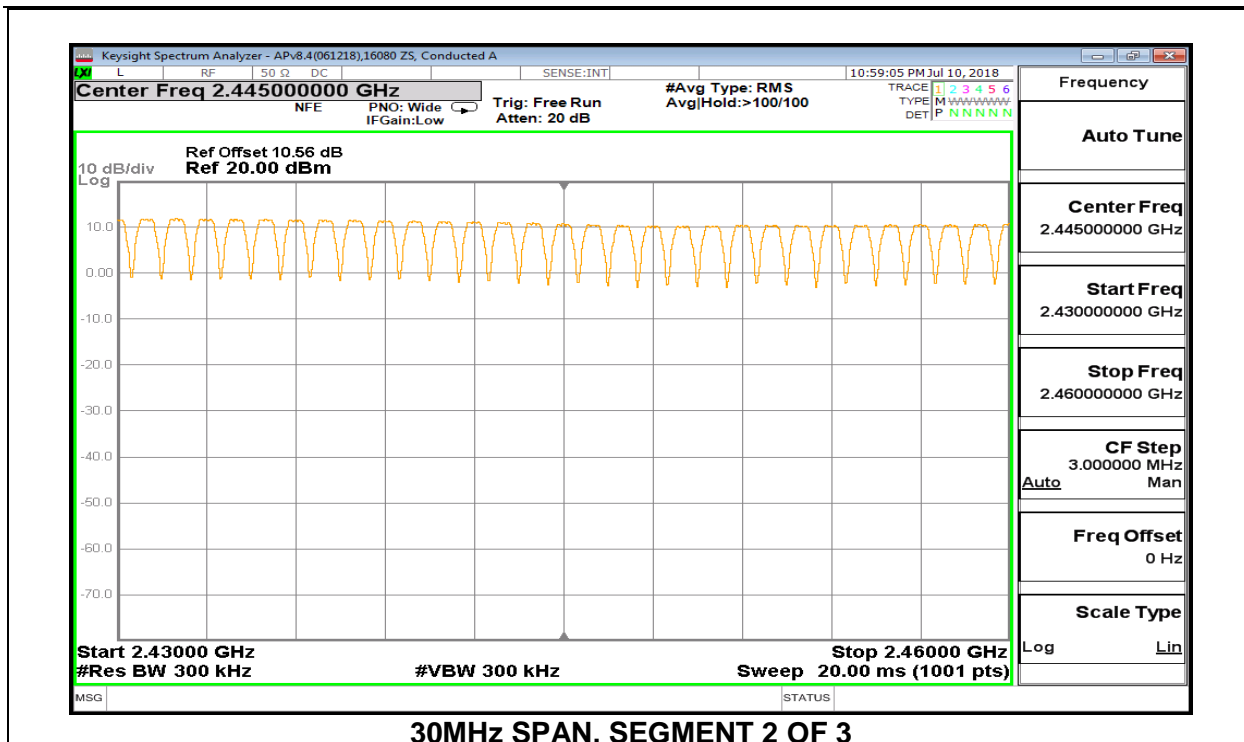

8.4.2. BLUETOOTH ENHANCED DATA RATE 8PSK MODULATION

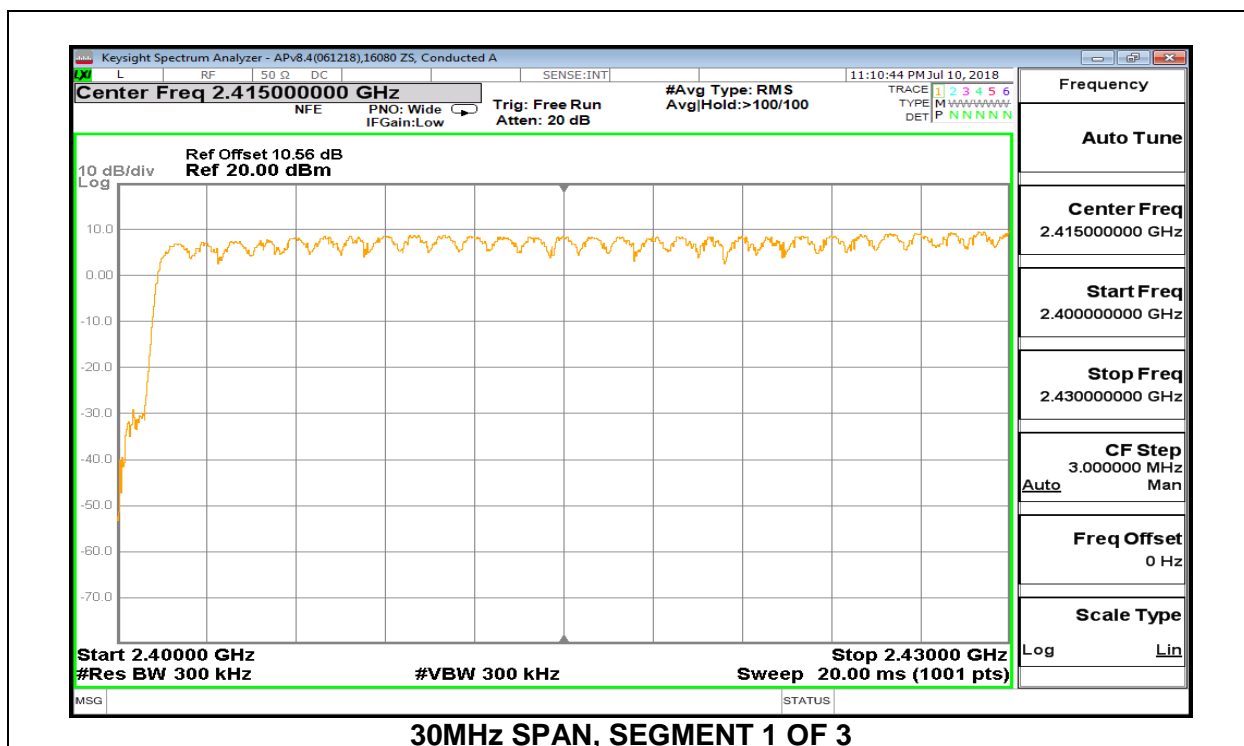
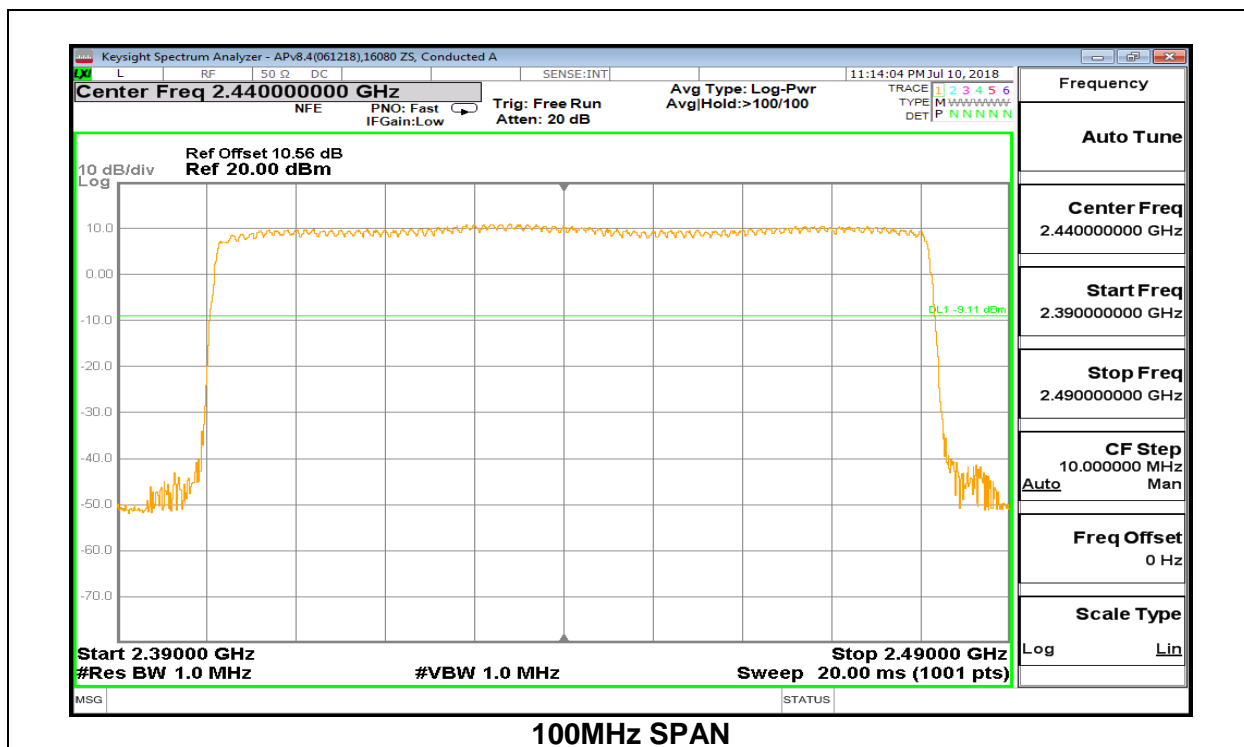

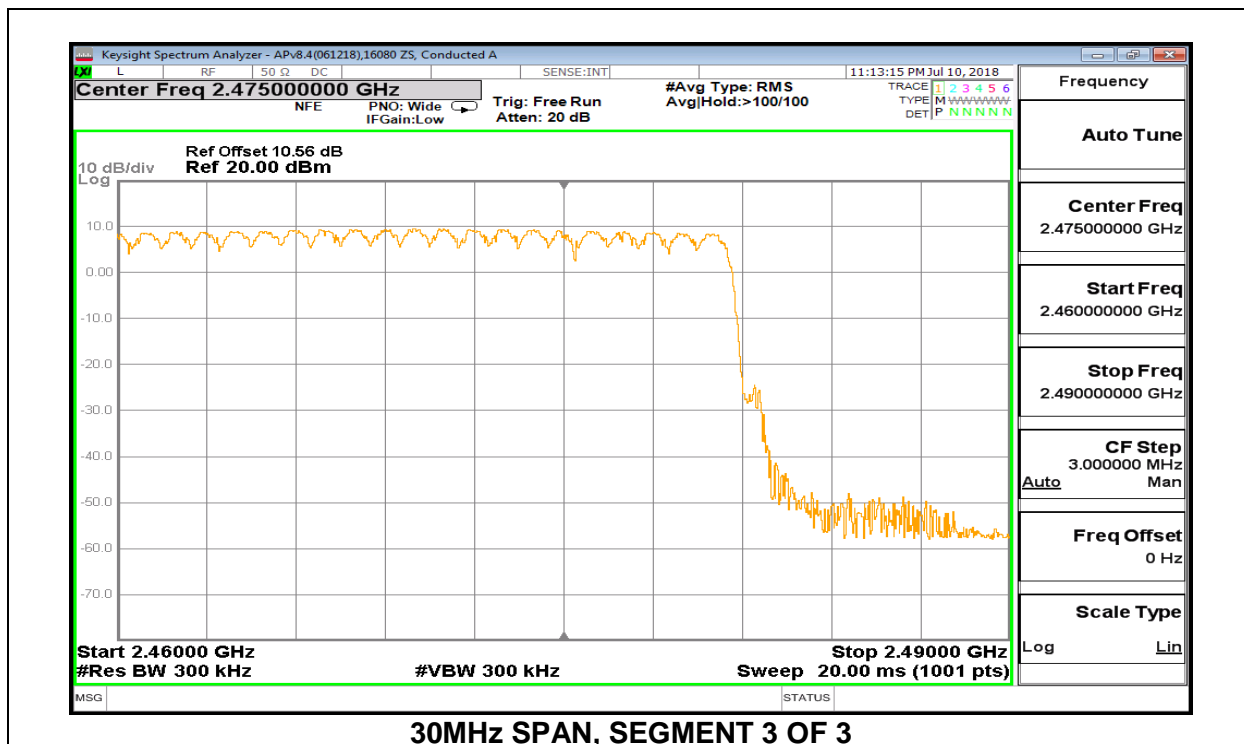
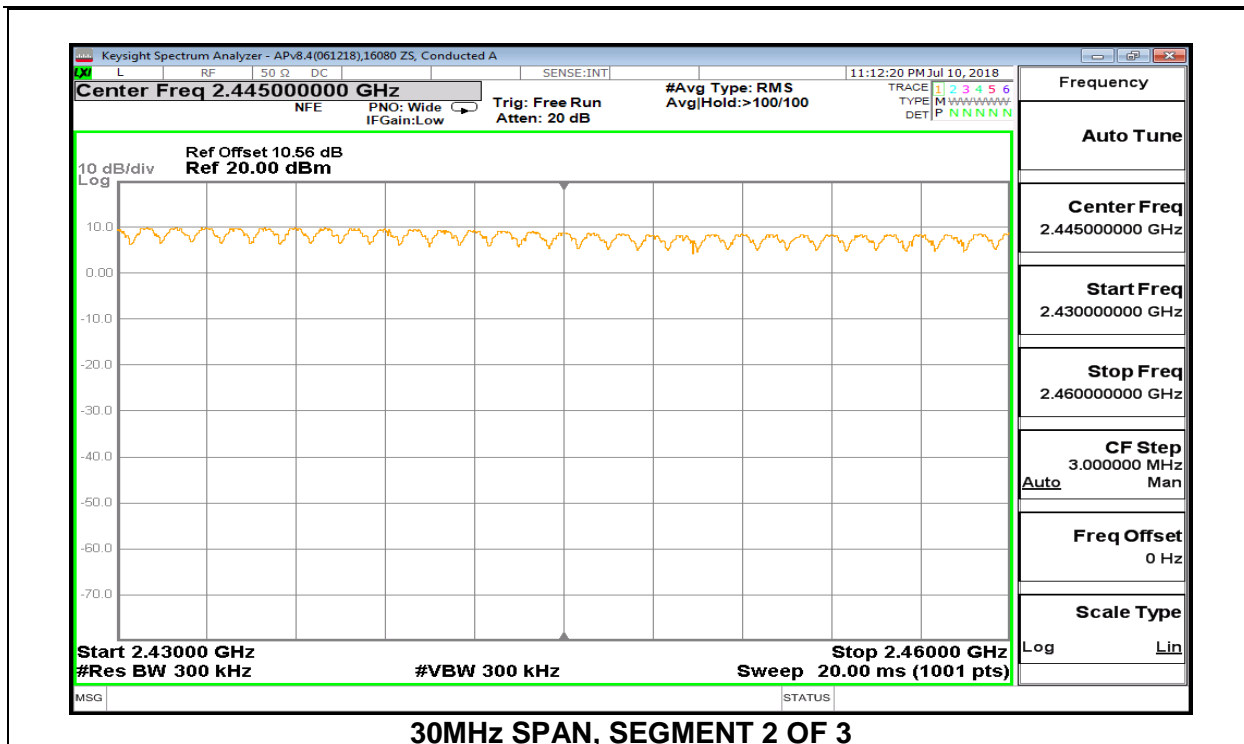

8.5. AVERAGE TIME OF OCCUPANCY

LIMITS

FCC §15.247 (a) (1) (iii)

The average time of occupancy on any channel shall not be greater than 0.4 seconds within a period of 0.4 seconds multiplied by the number of hopping channels employed.

TEST PROCEDURE

The transmitter output is connected to a spectrum analyzer. The span is set to 0 Hz, centered on a single, selected hopping channel. The width of a single pulse is measured in a fast scan. The number of pulses is measured in a 3.16 second scan, to enable resolution of each occurrence.

The average time of occupancy in the specified 3.16 second period (79 channels * 0.4 s) is equal to $10 * (\# \text{ of pulses in } 3.16 \text{ s}) * \text{ pulse width}$.

For AFH mode, the average time of occupancy in the specified 8 second period (20 channels * 0.4 seconds) is equal to $10 * (\# \text{ of pulses in } 0.8 \text{ s}) * \text{ pulse width}$.

RESULTS

8.5.1. BLUETOOTH BASIC DATA RATE GFSK MODULATION

DH Packet	Pulse Width (msec)	Number of Pulses in 3.16 seconds	Average Time of Occupancy (sec)	Limit (sec)	Margin (sec)
GFSK Normal Mode					
DH1	0.382	33	0.1261	0.4	-0.2739
DH3	1.639	16	0.2622	0.4	-0.1378
DH5	2.887	11	0.3176	0.4	-0.0824
DH Packet	Pulse Width (sec)	Number of Pulses in 0.8 seconds	Average Time of Occupancy (sec)	Limit (sec)	Margin (sec)
GFSK AFH Mode					
DH1	0.382	8.25	0.03152	0.4	-0.3685
DH3	1.639	4	0.06556	0.4	-0.3344
DH5	2.887	2.75	0.07939	0.4	-0.3206

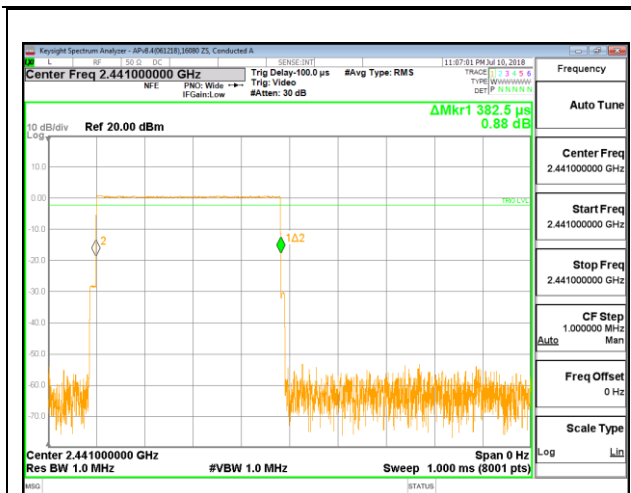

PULSE WIDTH – DH1

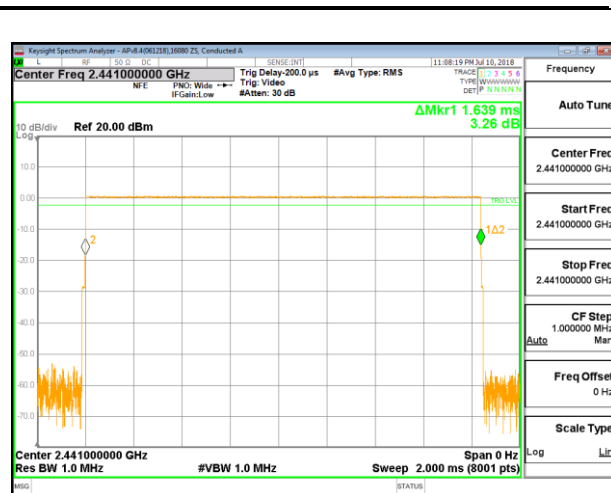

PULSE WIDTH – DH3

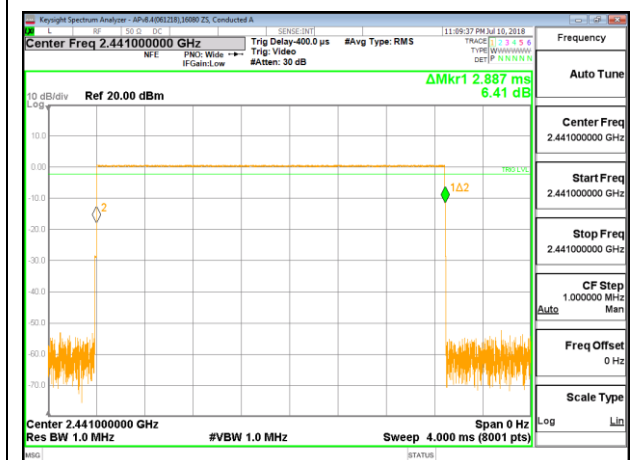

PULSE WIDTH – DH5

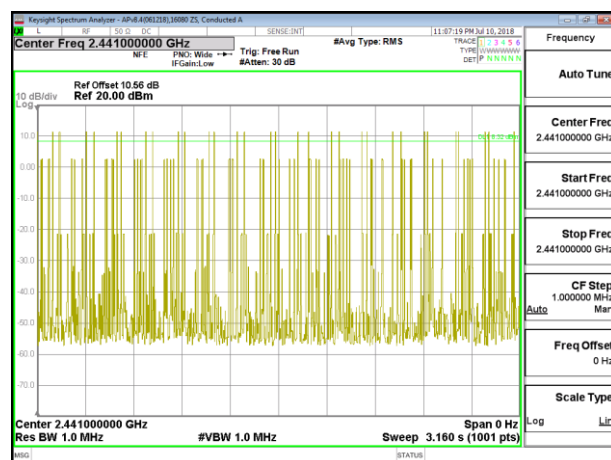

NUMBER OF PULSES IN 3.16 SECOND OBSERVATION PERIOD – DH1

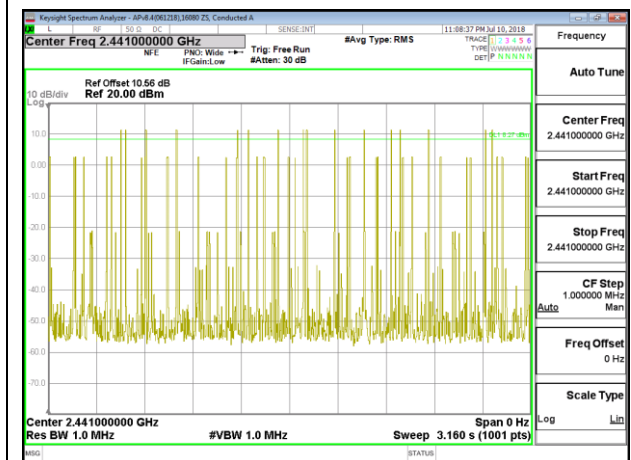

NUMBER OF PULSES IN 3.16 SECOND OBSERVATION PERIOD – DH3

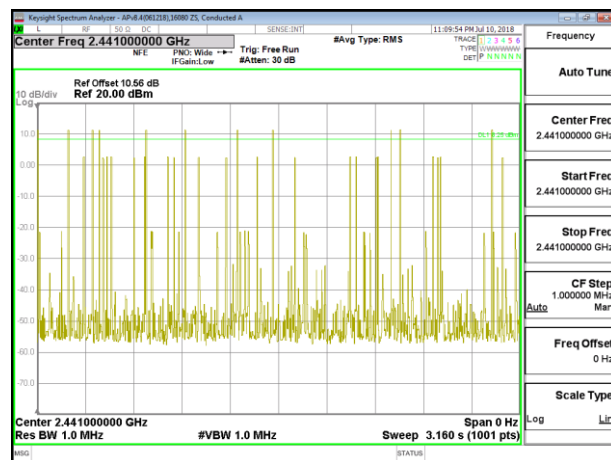

NUMBER OF PULSES IN 3.16 SECOND OBSERVATION PERIOD – DH5

8.5.2. BLUETOOTH ENHANCED DATA RATE 8PSK MODULATION

DH Packet	Pulse Width (msec)	Number of Pulses in 3.16 seconds	Average Time of Occupancy (sec)	Limit (sec)	Margin (sec)
8PSK Normal Mode					
DH1	0.389	31	0.12059	0.4	-0.27941
DH3	1.64	15	0.246	0.4	-0.154
DH5	2.89	14	0.4046	0.4	0.0046

Note: for AFH(8PSK) mode, please refer to the results of AFH(GFSK) mode; the channel selection and hopping rate are the same for both EDR and Basic Rate operation, data for Basic Rate in section 4.5.1 demonstrates compliance with channel occupancy when AFH is employed.

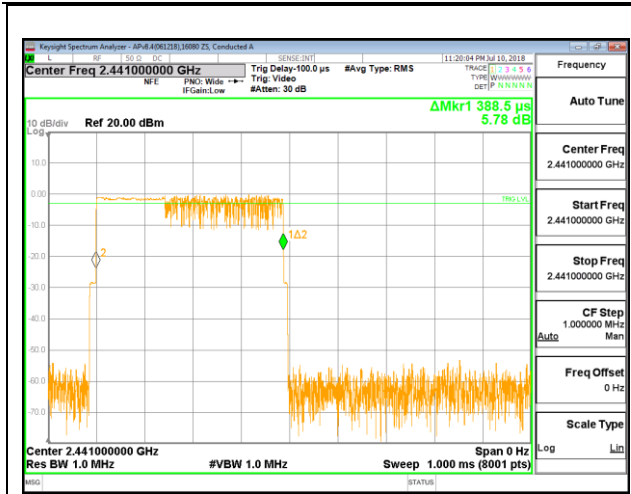

PULSE WIDTH – DH1

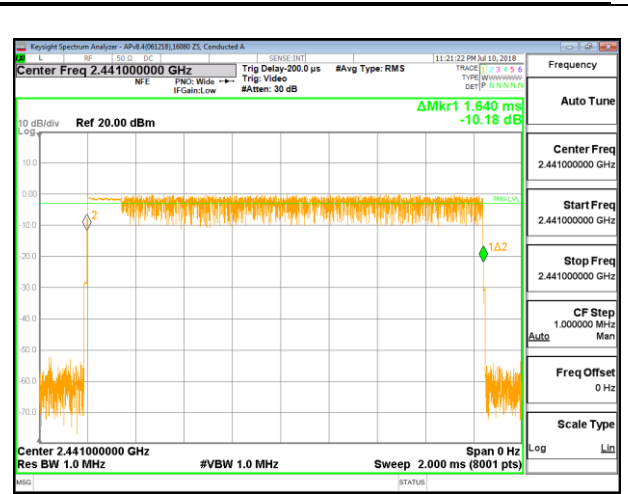

PULSE WIDTH – DH3

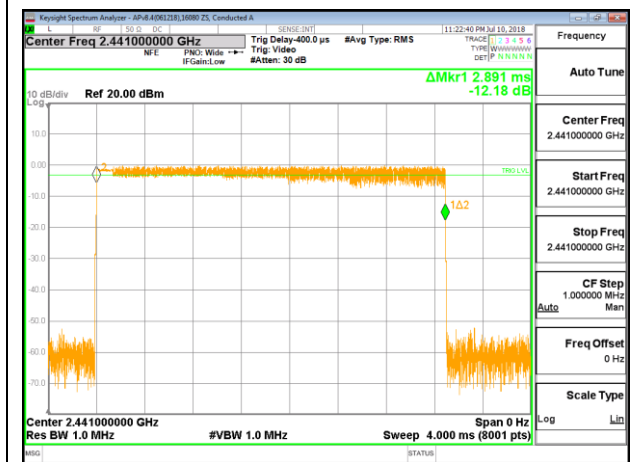

PULSE WIDTH – DH5

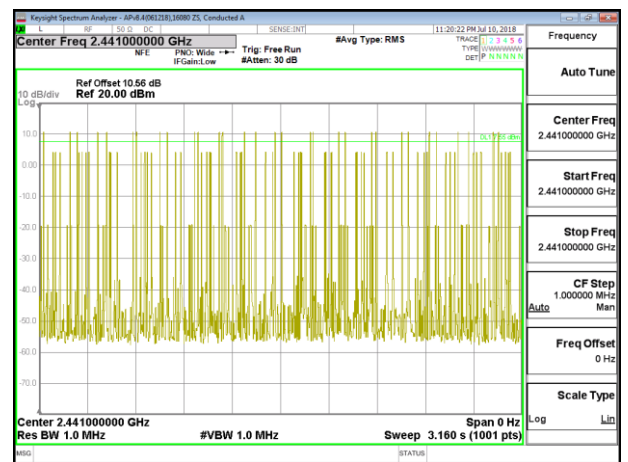

NUMBER OF PULSES IN 3.16 SECOND OBSERVATION PERIOD – DH1

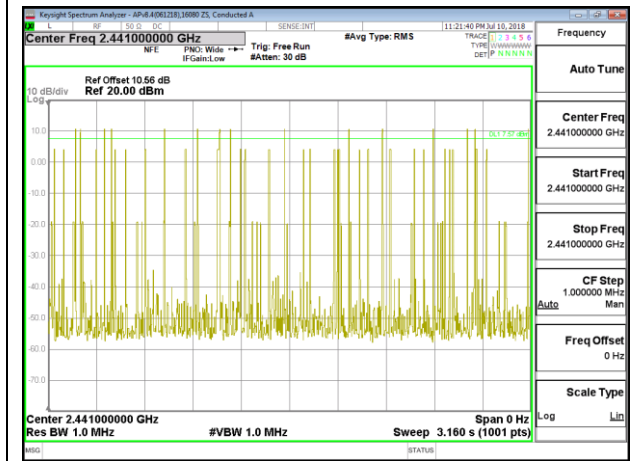

NUMBER OF PULSES IN 3.16 SECOND OBSERVATION PERIOD – DH3

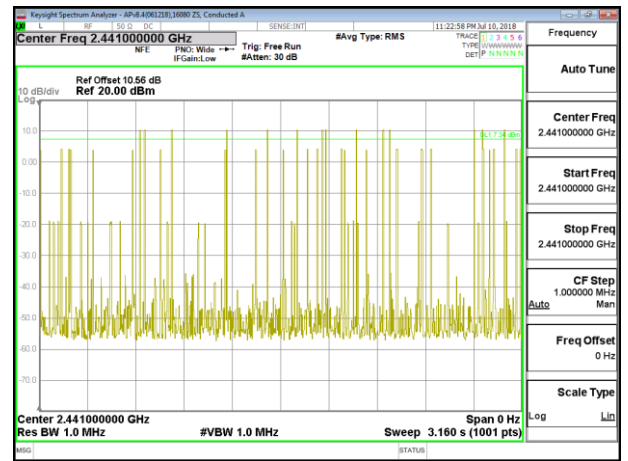

NUMBER OF PULSES IN 3.16 SECOND OBSERVATION PERIOD – DH5

8.6. OUTPUT POWER

LIMITS

§15.247 (b) (1)

The maximum antenna gain is less than 6 dBi, therefore the limit is 30 dBm. Alternatively, frequency hopping systems operating in the 2400-2483.5 MHz band may have hopping channel carrier frequencies that are separated by 25 kHz or two-thirds of the 20 dB bandwidth of the hopping channel, whichever is greater, provided the systems operate with an output power no greater than 125 mW.

TEST PROCEDURE

The transmitter output is connected to a power meter. The cable assembly insertion loss was entered as an offset in the power meter to allow for a gated peak reading of power.

RESULTS

8.6.1. BLUETOOTH BASIC DATA RATE GFSK MODULATION

Tested By:	GE43578
Date:	7/7/2018

Channel	Frequency (MHz)	Output Power (dBm)	Limit (dBm)	Margin (dB)
Low	2402	10.54	30	-19.46
Middle	2441	11.41	30	-18.59
High	2480	10.37	30	-19.63

8.6.2. BLUETOOTH ENCHANCED DATA RATE 8PSK MODULATION

Tested By:	GE43578
Date:	7/7/2018

Channel	Frequency (MHz)	Output Power (dBm)	Limit (dBm)	Margin (dB)
Low	2402	8.40	21	-12.6
Middle	2441	9.17	21	-11.83
High	2480	8.44	21	-12.56

8.7. AVERAGE POWER

LIMITS

None; for reporting purposes only

TEST PROCEDURE

The transmitter output is connected to a power meter. The cable assembly insertion loss of was entered as an offset in the power meter to allow for a gated average reading of power.

RESULTS

8.7.1. BLUETOOTH BASIC DATA RATE GFSK MODULATION

Tested By:	GE43578
Date	7/72018

Channel	Frequency (MHz)	Average Power (dBm)
Low	2402	10.43
Middle	2441	11.18
High	2480	10.27

8.7.2. BLUETOOTH ENCHANCED DATA RATE 8PSK MODULATION

Tested By:	GE43578
Date	7/7/2018

Channel	Frequency (MHz)	Average Power (dBm)
Low	2402	8.04
Middle	2441	8.78
High	2480	8.08

8.8. CONDUCTED SPURIOUS EMISSIONS

LIMITS

FCC §15.247 (d)

Limit = -20 dBc

TEST PROCEDURE

The transmitter output is connected to a spectrum analyzer. The resolution bandwidth is set to 100 kHz. The video bandwidth is set to 300 kHz.

The spectrum from 30 MHz to 26 GHz is investigated with the transmitter set to the lowest, middle, and highest channels.

The bandedges at 2.4 and 2.4835 GHz are investigated with the transmitter set to the normal hopping mode.

RESULTS

8.8.1. BLUETOOTH BASIC DATA RATE GFSK MODULATION

Antenna 1 SPURIOUS EMISSIONS, NON-HOPPING

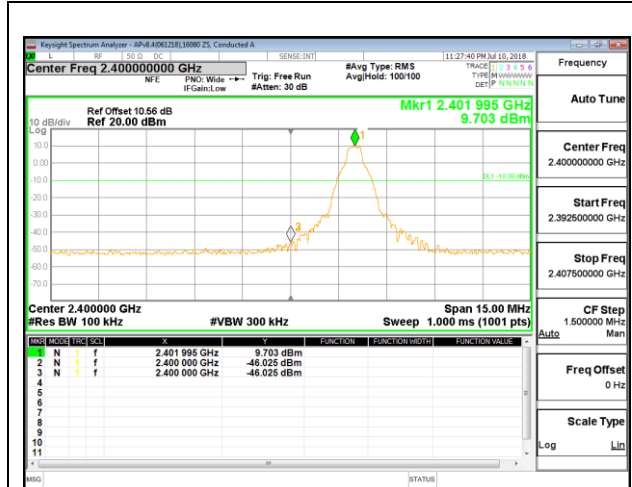

LOW CHANNEL BANDEDGE

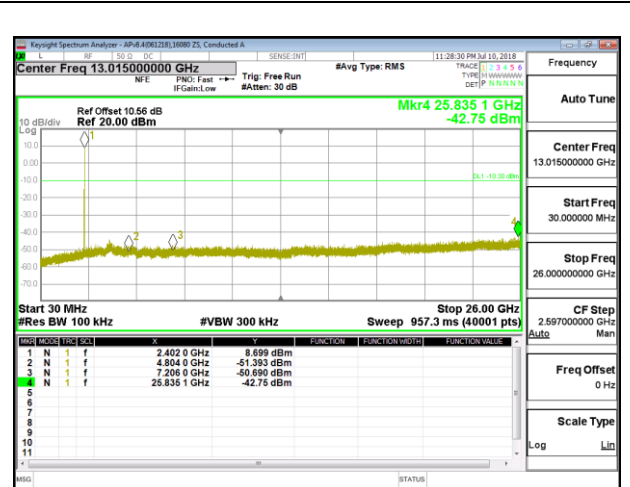

OUT-OF-BAND LOW CHANNEL

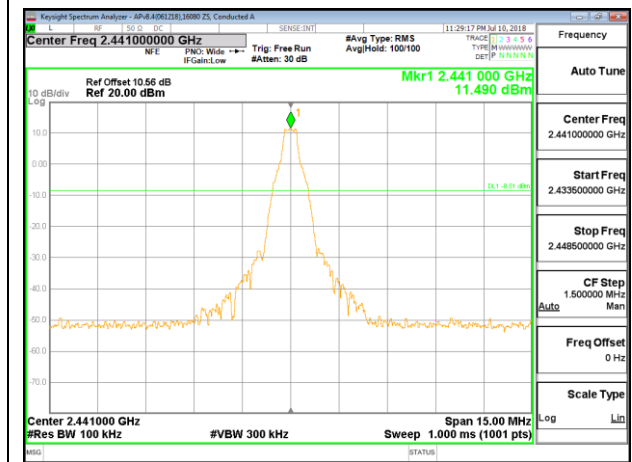

IN-BAND REFERENCE LEVEL

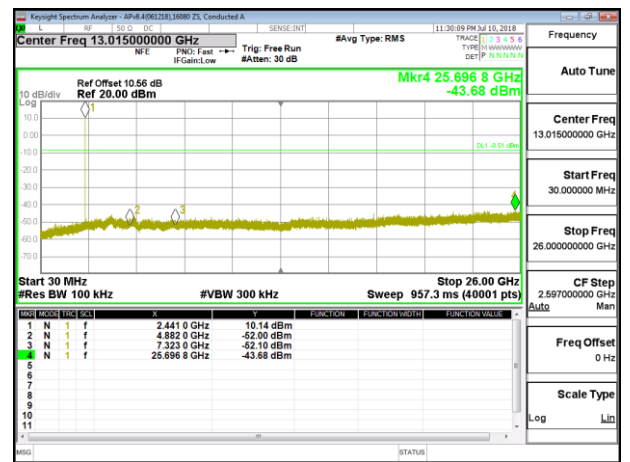

OUT-OF-BAND MID CHANNEL

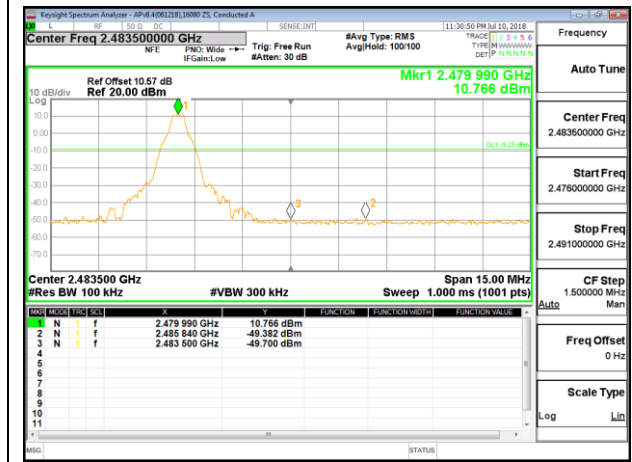

HIGH CHANNEL BANDEDGE

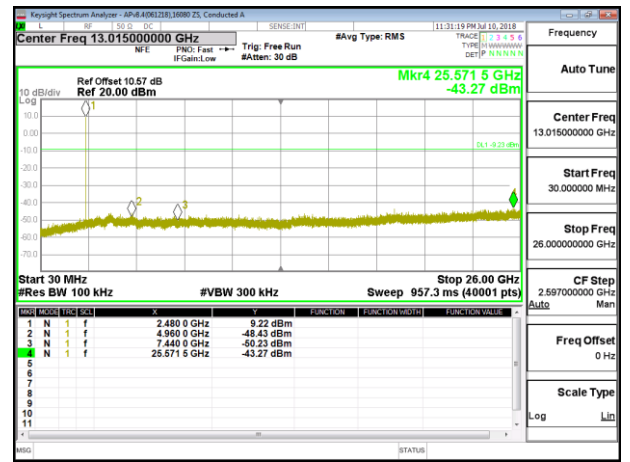

OUT-OF-BAND HIGH CHANNEL

Antenna 1 SPURIOUS BANDEDGE EMISSIONS WITH HOPPING ON

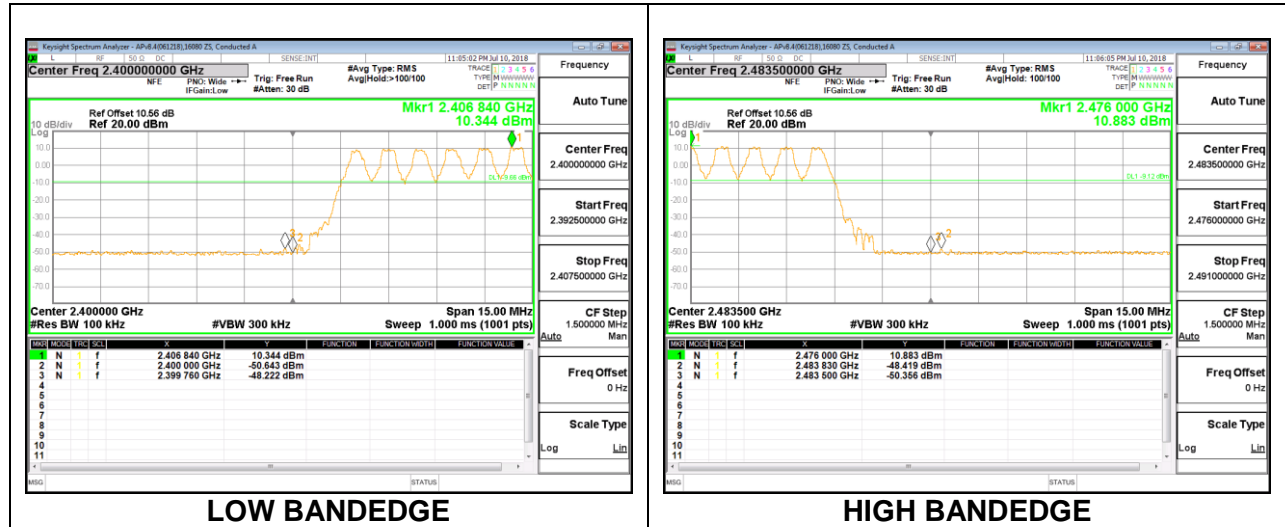

8.8.2. BLUETOOTH ENHANCED DATA RATE 8PSK MODULATION

Antenna 1 SPURIOUS EMISSIONS, NON-HOPPING

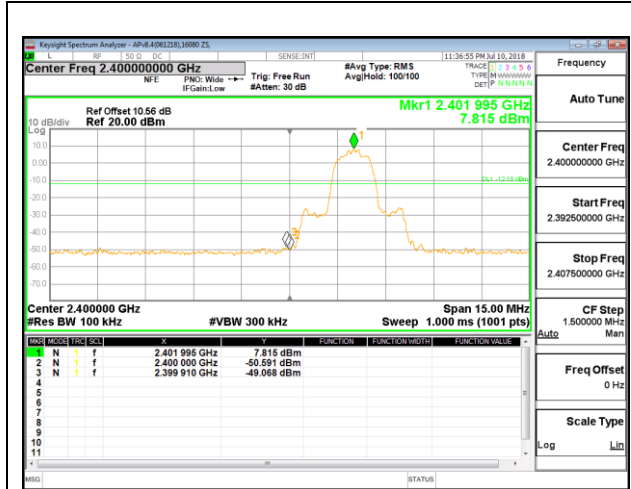

LOW CHANNEL BANDEDGE

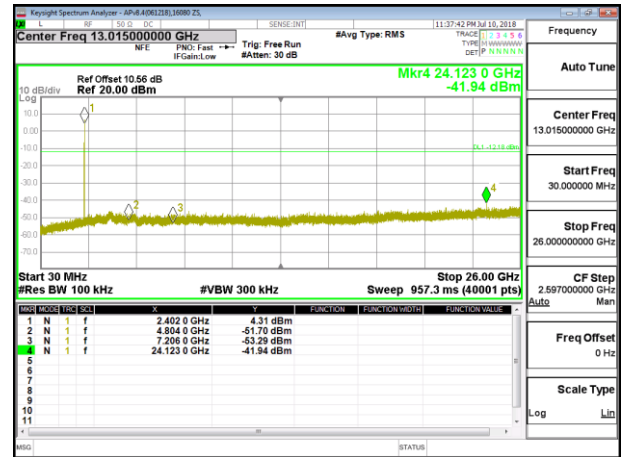

OUT-OF-BAND LOW CHANNEL

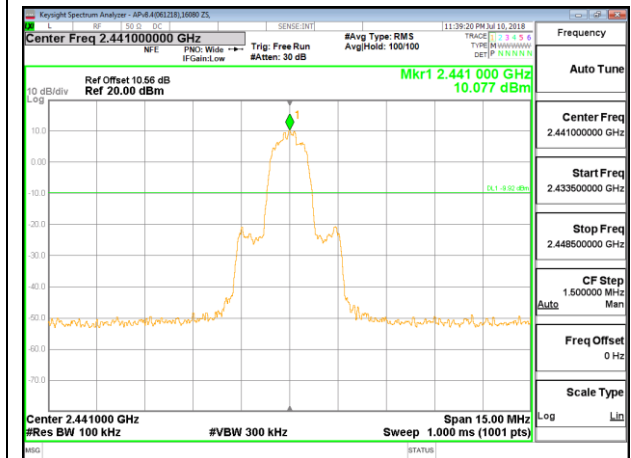

IN-BAND REFERENCE LEVEL

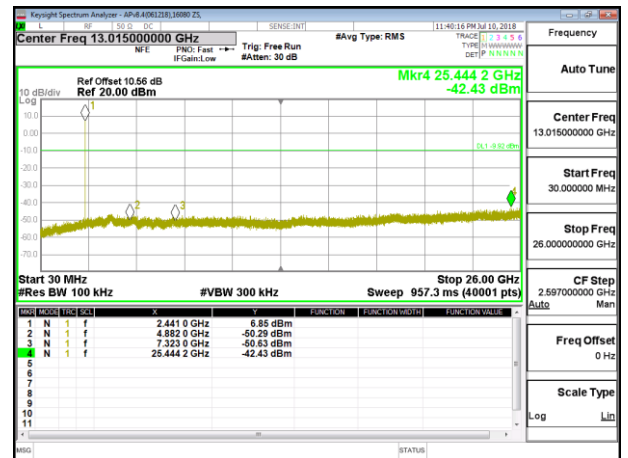

OUT-OF-BAND MID CHANNEL

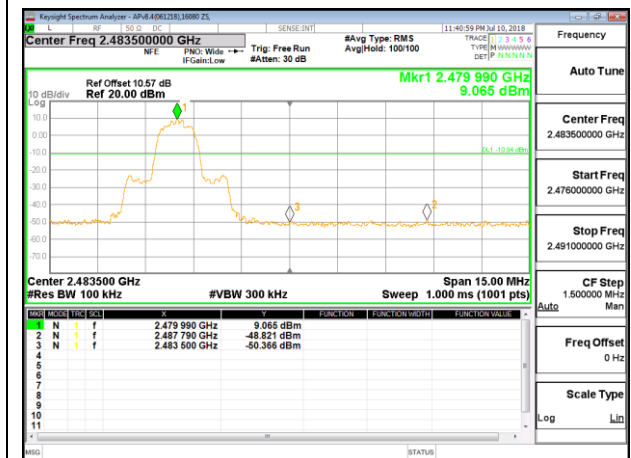

HIGH CHANNEL BANDEDGE

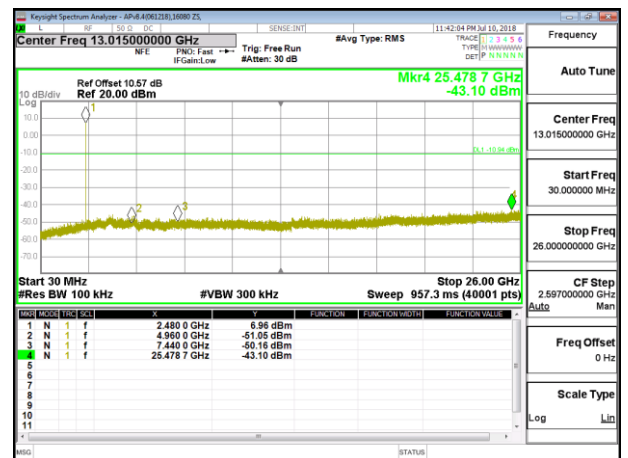

OUT-OF-BAND HIGH CHANNEL

Antenna 1 SPURIOUS BANDEDGE EMISSIONS WITH HOPPING ON

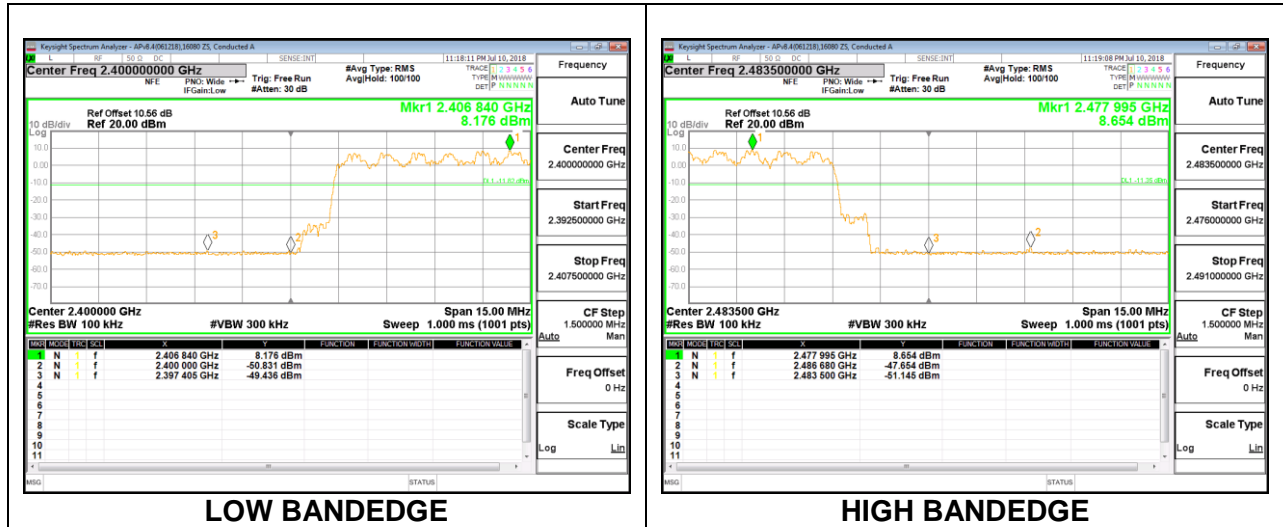

9. RADIATED TEST RESULTS

LIMITS

FCC §15.205 and §15.209

Frequency Range (MHz)	Field Strength Limit (uV/m) at 3 m	Field Strength Limit (dBuV/m) at 3 m
0.009-0.490	2400/F(kHz) @ 300 m	-
0.490-1.705	24000/F(kHz) @ 30 m	-
1.705 - 30	30 @ 30m	-
30 - 88	100	40
88 - 216	150	43.5
216 - 960	200	46
Above 960	500	54

TEST PROCEDURE

The EUT is placed on a non-conducting table 80 cm above the ground plane for measurement below 1GHz; 1.5 m above the ground plane for measurement above 1GHz. The antenna to EUT distance is 3 meters. The EUT is configured in accordance with ANSI C63.10. The EUT is set to transmit in a continuous mode.

For measurements below 1 GHz the resolution bandwidth is set to 100 kHz for peak detection measurements or 120 kHz for quasi-peak detection measurements. Peak detection is used unless otherwise noted as quasi-peak.

For pre-scans above 1 GHz the resolution bandwidth is set to 1 MHz; the video bandwidth is set to 30 KHz for peak measurements.

For measurements above 1 GHz the resolution bandwidth is set to 1 MHz, then the video bandwidth is set to 3 MHz for peak measurements and 1 MHz resolution bandwidth with 1/T (360 Hz) video bandwidth with peak detector for average measurements.

The spectrum from 1 GHz to 18 GHz is investigated with the transmitter set to the lowest, middle, and highest channels in each applicable band. Below 1GHz and above 18GHz emissions, the channel with the highest output power was tested.

The frequency range of interest is monitored at a fixed antenna height and EUT azimuth. The EUT is rotated through 360 degrees to maximize emissions received. The antenna is scanned from 1 to 4 meters above the ground plane to further maximize the emission. Measurements are made with the antenna polarized in both the vertical and the horizontal positions.

9.1. TRANSMITTER ABOVE 1 GHz

9.1.1. BLUETOOTH BASIC DATA RATE GFSK MODULATION

BANDEDGE (LOW CHANNEL)

HORIZONTAL RESULT

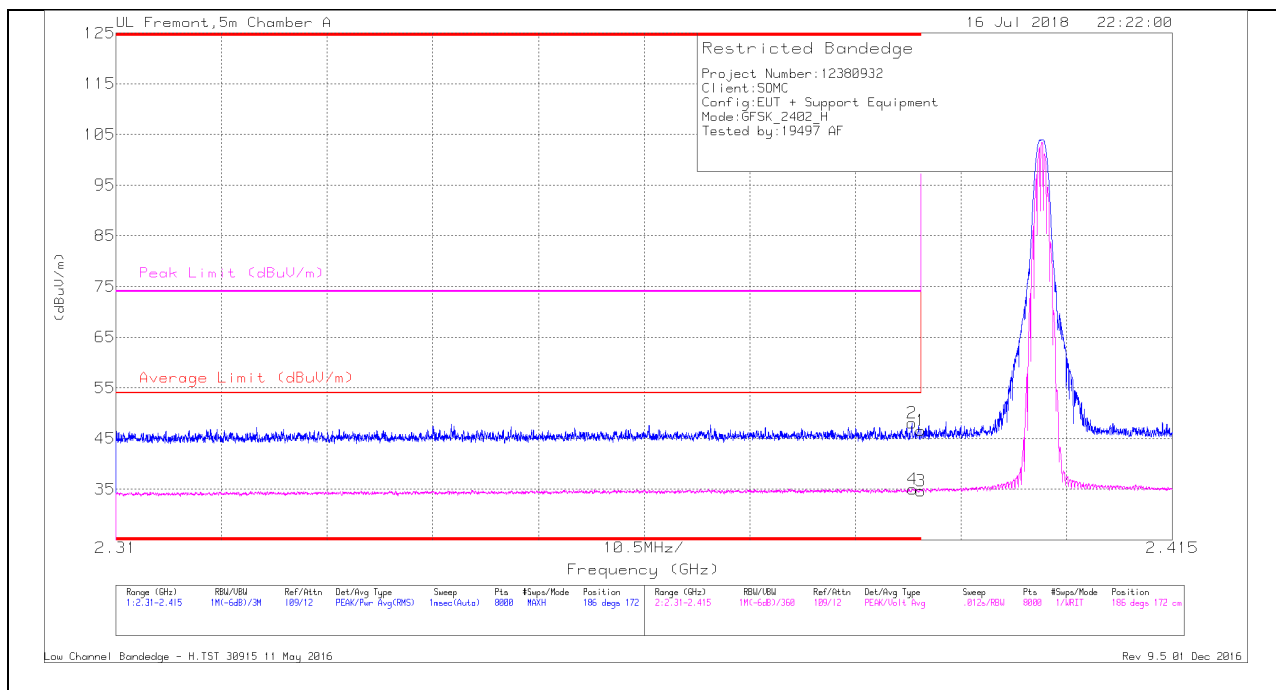

Trace Markers

Marker	Frequency (GHz)	Meter Reading (dBuV)	Det	AF T345 (dB/m)	Amp/Cbl/Filtr/Pad (dB)	Corrected Reading (dBuV/m)	Average Limit (dBuV/m)	Margin (dB)	Peak Limit (dBuV/m)	PK Margin (dB)	Azimuth (Degs)	Height (cm)	Polarity
1	* 2.39	37.81	Pk	31.8	-23	46.61	-	-	74	-27.39	186	172	H
2	* 2.389	39.24	Pk	31.8	-23	48.04	-	-	74	-25.96	186	172	H
3	* 2.39	25.9	VA1T	31.8	-23	34.7	54	-19.3	-	-	186	172	H
4	* 2.389	26.26	VA1T	31.8	-23	35.06	54	-18.94	-	-	186	172	H

* - indicates frequency in CFR47 Pt 15 Restricted Band

Pk - Peak detector

VA1T - FHSS: Linear Voltage Average VB=1/Ton where: Ton is transmit duration

VERTICAL RESULT

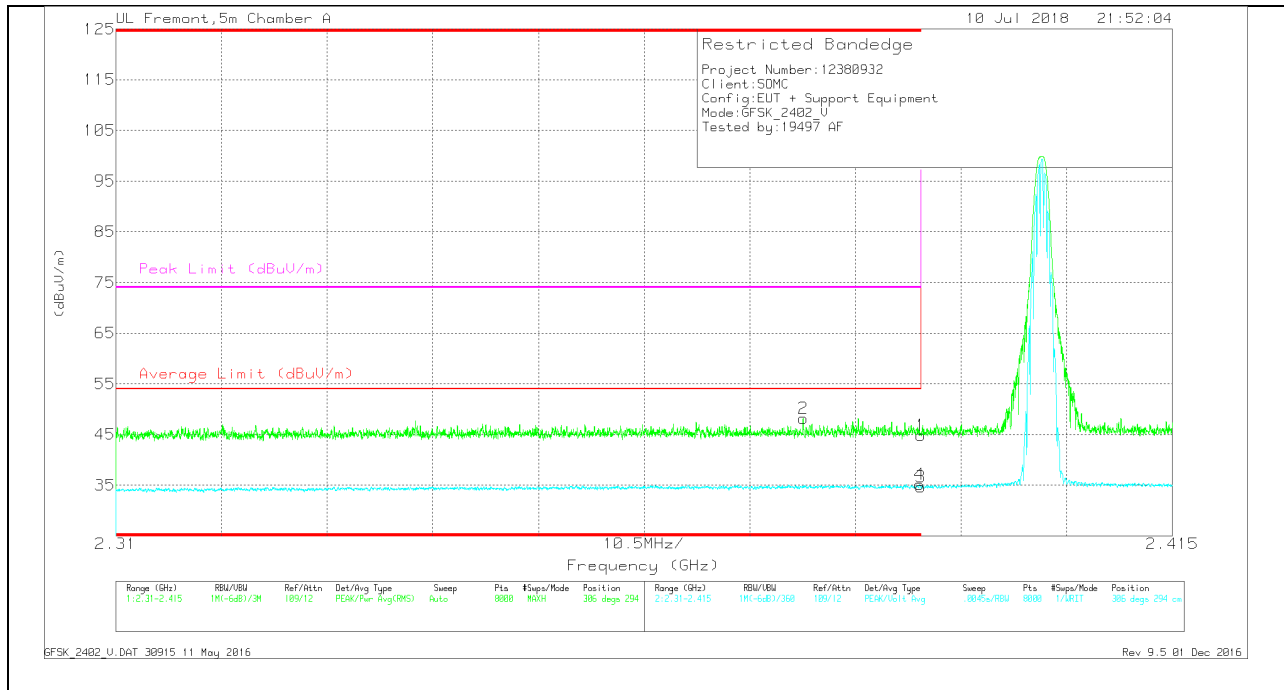

Trace Markers

Marker	Frequency (GHz)	Meter Reading (dBuV)	Det	AF T345 (dB/m)	Amp/Cb/Filtr/Pad (dB)	Corrected Reading (dBuV/m)	Average Limit (dBuV/m)	Margin (dB)	Peak Limit (dBuV/m)	PK Margin (dB)	Azimuth (Degs)	Height (cm)	Polarity
1	* 2.39	36	Pk	31.8	-23	44.8	-	-	74	-29.2	306	294	V
2	* 2.378	39.52	Pk	31.7	-23	48.22	-	-	74	-25.78	306	294	V
3	* 2.39	25.83	VA1T	31.8	-23	34.63	54	-19.37	-	-	306	294	V
4	* 2.39	26.33	VA1T	31.8	-23	35.13	54	-18.87	-	-	306	294	V

* - indicates frequency in CFR47 Pt 15 Restricted Band

Pk - Peak detector

VA1T - FHSS: Linear Voltage Average $V_B=1/T_{on}$ where: T_{on} is transmit duration

BANDEDGE (HIGH CHANNEL)

HORIZONTAL RESULT

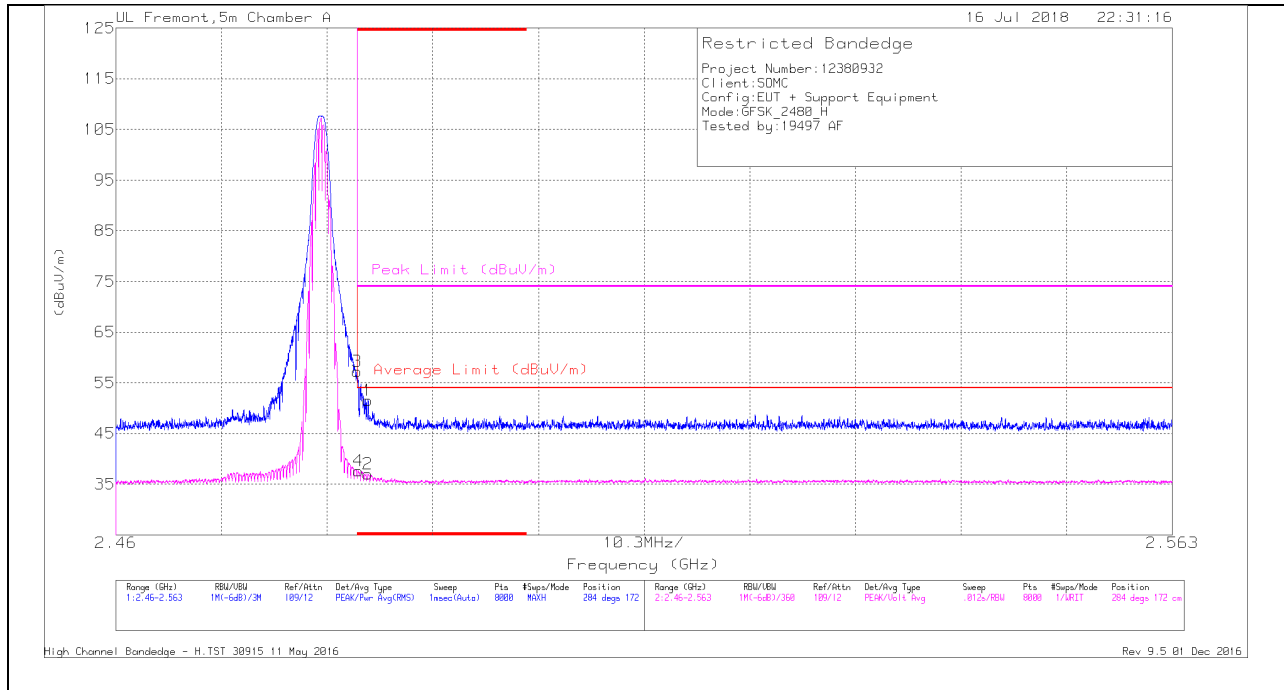

Trace Markers

Marker	Frequency (GHz)	Meter Reading (dBuV)	Det	AF T345 (dB/m)	Amp/Cbl/Filtr/Pad (dB)	Corrected Reading (dBuV/m)	Average Limit (dBuV/m)	Margin (dB)	Peak Limit (dBuV/m)	PK Margin (dB)	Azimuth (Degs)	Height (cm)	Polarity
1	* 2.485	42.17	Pk	32.3	-22.9	51.57	-	-	74	-22.43	284	172	H
3	* 2.484	47.84	Pk	32.3	-22.9	57.24	-	-	74	-16.76	284	172	H
2	* 2.485	27.55	VA1T	32.3	-22.9	36.95	54	-17.05	-	-	284	172	H
4	* 2.484	28.26	VA1T	32.3	-22.9	37.66	54	-16.34	-	-	284	172	H

* - indicates frequency in CFR47 Pt 15 Restricted Band

Pk - Peak detector

VA1T - FHSS: Linear Voltage Average VB=1/Ton where: Ton is transmit duration

VERTICAL RESULT

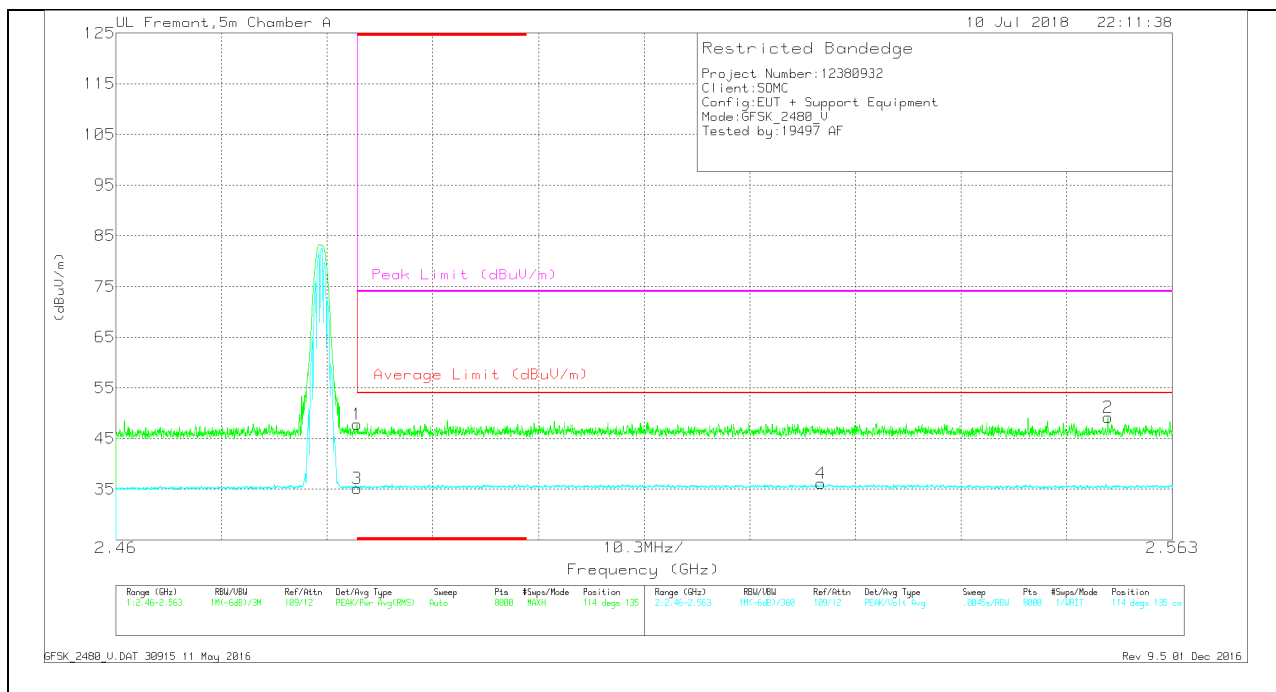

Trace Markers

Marker	Frequency (GHz)	Meter Reading (dBuV)	Det	AF T345 (dB/m)	Amp/Cbl/Filtr/Pad (dB)	Corrected Reading (dBuV/m)	Average Limit (dBuV/m)	Margin (dB)	Peak Limit (dBuV/m)	PK Margin (dB)	Azimuth (Degs)	Height (cm)	Polarity
1	* 2.484	38.37	Pk	32.3	-22.9	47.77	-	-	74	-26.23	114	135	V
3	* 2.484	25.79	VA1T	32.3	-22.9	35.19	54	-18.81	-	-	114	135	V
4	2.529	26.52	VA1T	32.4	-22.8	36.12	54	-17.88	-	-	114	135	V
2	2.557	39.65	Pk	32.3	-22.8	49.15	-	-	74	-24.85	114	135	V

* - indicates frequency in CFR47 Pt 15 Restricted Band

Pk - Peak detector

VA1T - FHSS: Linear Voltage Average $VB=1/Ton$ where: Ton is transmit duration

HARMONICS AND SPURIOUS EMISSIONS

LOW CHANNEL RESULTS

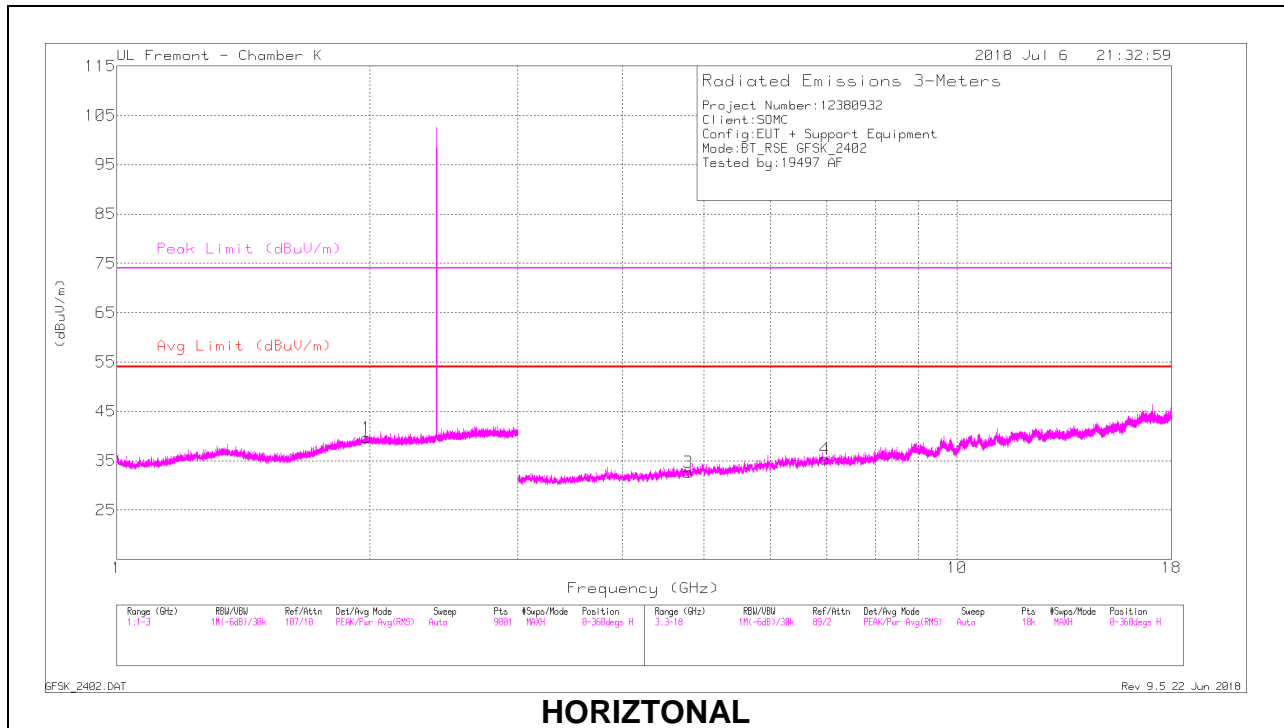

HORIZONTAL

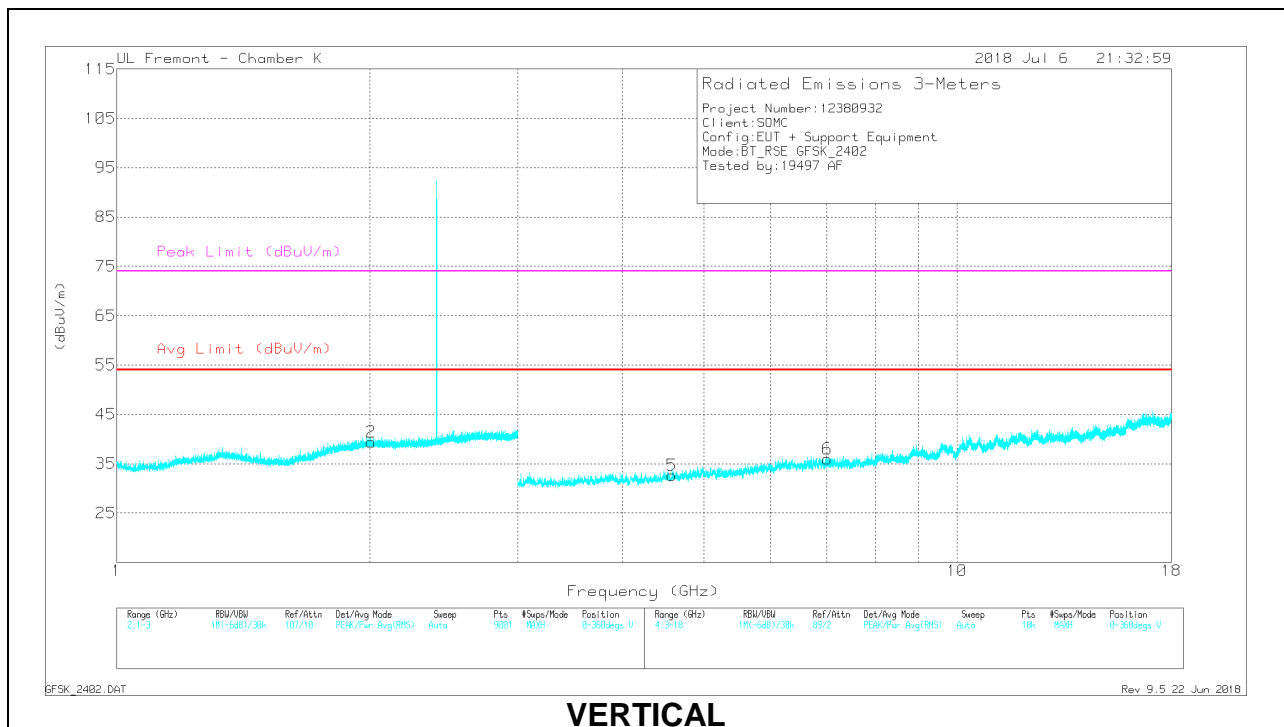

VERTICAL

RADIATED EMISSIONS

Radiated Emissions

Marker	Frequency (GHz)	Meter Reading (dBuV)	Det	AF T345 (dB/m)	Amp/Cb/Filtr/Pad (dB)	Corrected Reading (dBuV/m)	Avg Limit (dBuV/m)	Margin (dB)	Peak Limit (dBuV/m)	PK Margin (dB)	Azimuth (Degs)	Height (cm)	Polarity
1	1.983	39.95	PKFH	31.6	-23.6	47.95	-	-	-	-	321	202	H
	1.983	26.86	VA1T	31.6	-23.6	34.86	-	-	-	-	321	202	H
2	2.008	38.82	PKFH	31.7	-23.5	47.02	-	-	-	-	348	195	V
	2.007	26.78	VA1T	31.7	-23.5	34.98	-	-	-	-	348	195	V
3	* 4.791	35.82	PKFH	34.2	-28.8	41.22	-	-	74	-32.78	271	141	H
	* 4.79	22.78	VA1T	34.2	-28.8	28.18	54	-25.82	-	-	271	141	H
4	6.957	34.2	PKFH	35.7	-25.7	44.2	-	-	-	-	342	232	H
	6.959	20.61	VA1T	35.7	-25.7	30.61	-	-	-	-	342	232	H
5	* 4.576	35.26	PKFH	34	-29.4	39.86	-	-	74	-34.14	333	269	V
	* 4.577	23.36	VA1T	34	-29.3	28.06	54	-25.94	-	-	333	269	V
6	7.015	32.99	PKFH	35.7	-26	42.69	-	-	-	-	120	263	V
	7.013	21.03	VA1T	35.8	-26	30.83	-	-	-	-	120	263	V

* - indicates frequency in CFR47 Pt 15 Restricted Band

PKFH - FHSS: RB=100k/1MHz VB=3 x RB, Peak

VA1T - FHSS: Linear Voltage Average VB=1/Ton where: Ton is transmit duration

MID CHANNEL RESULTS

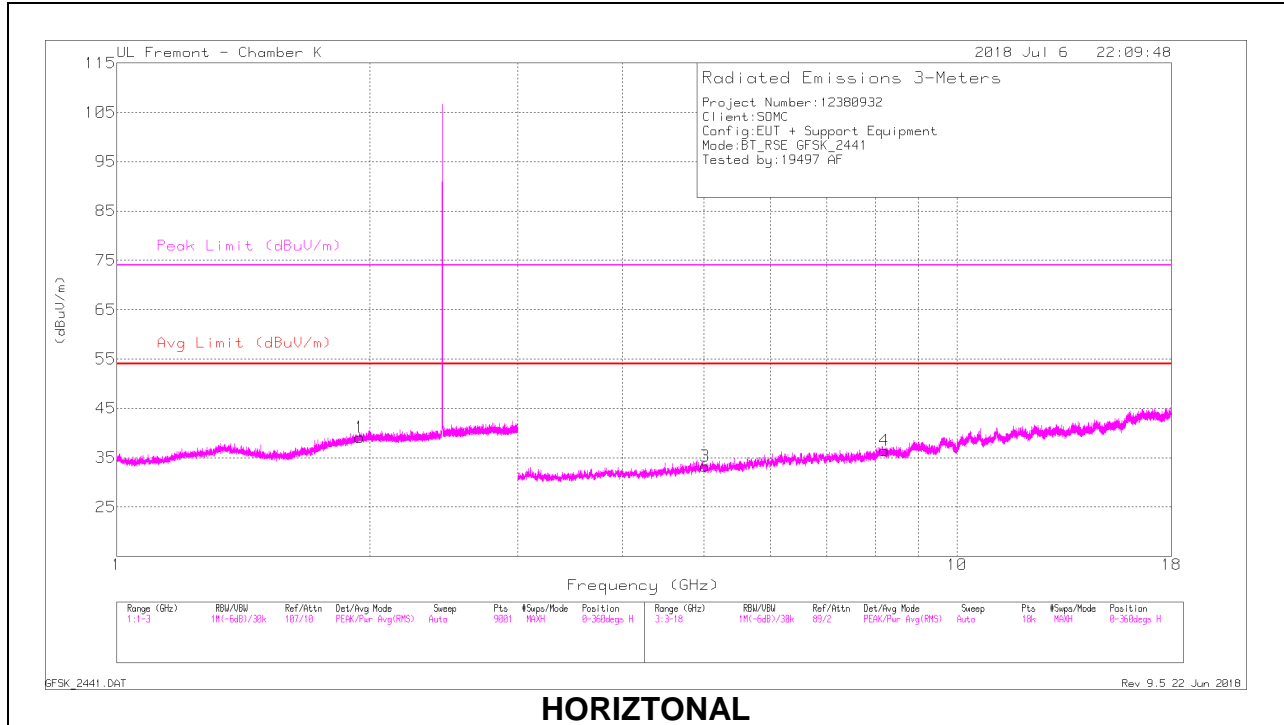

HORIZONTAL

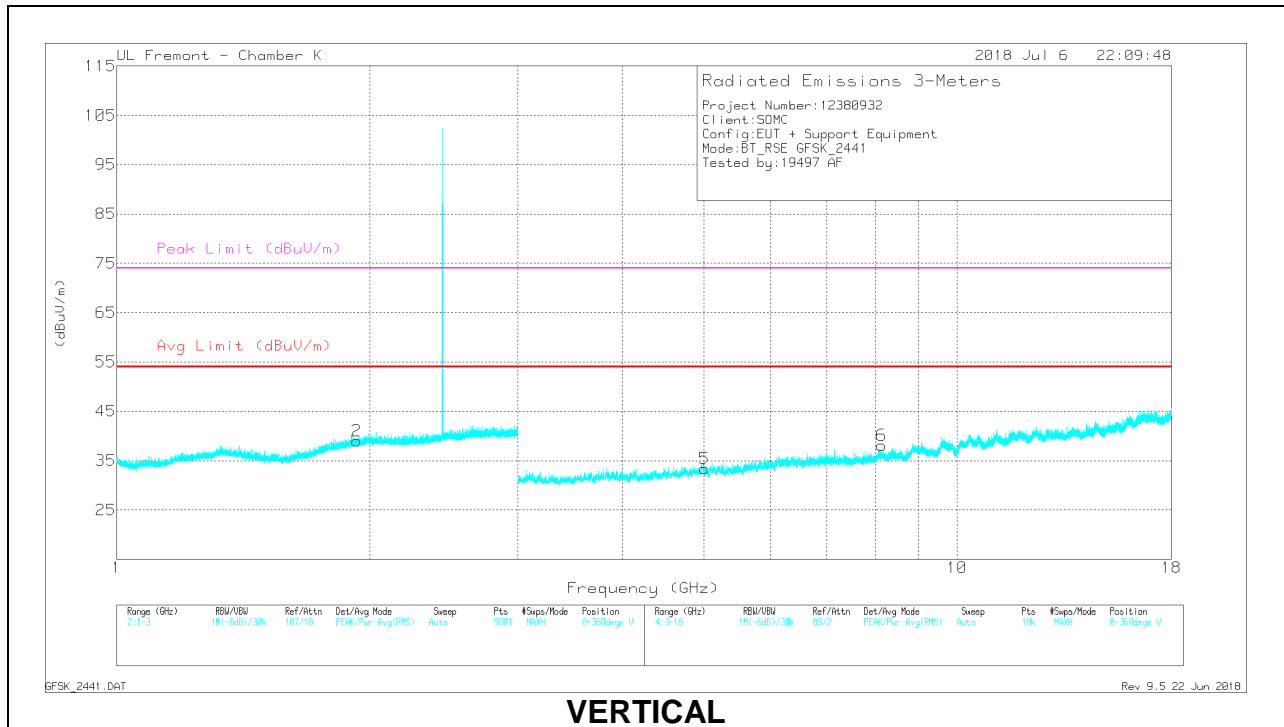

VERTICAL

RADIATED EMISSIONS

Radiated Emissions

Marker	Frequency (GHz)	Meter Reading (dBuV)	Det	AF T345 (dB/m)	Amp/Cb/Filtr/Pad (dB)	Corrected Reading (dBuV/m)	Avg Limit (dBuV/m)	Margin (dB)	Peak Limit (dBuV/m)	PK Margin (dB)	Azimuth (Degs)	Height (cm)	Polarity
1	1.948	39.53	PKFH	31.4	-23.6	47.33	-	-	-	-	93	335	H
	1.946	26.94	VA1T	31.4	-23.6	34.74	-	-	-	-	93	335	H
2	1.93	39.14	PKFH	31.3	-23.7	46.74	-	-	-	-	116	330	V
	1.93	27.02	VA1T	31.3	-23.7	34.62	-	-	-	-	116	330	V
3	* 5.013	35.88	PKFH	34.4	-28.8	41.48	-	-	74	-32.52	101	371	H
	* 5.013	23.12	VA1T	34.4	-28.9	28.62	54	-25.38	-	-	101	371	H
4	* 8.195	33.05	PKFH	35.8	-23.7	45.15	-	-	74	-28.85	11	117	H
	* 8.199	19.61	VA1T	35.8	-23.7	31.71	54	-22.29	-	-	11	117	H
5	* 5.011	36	PKFH	34.4	-28.9	41.5	-	-	74	-32.5	294	272	V
	* 5.008	23.32	VA1T	34.4	-28.9	28.82	54	-25.18	-	-	294	272	V
6	* 8.134	31.53	PKFH	35.8	-23.1	44.23	-	-	74	-29.77	321	242	V
	* 8.133	18.91	VA1T	35.8	-23.1	31.61	54	-22.39	-	-	321	242	V

* - indicates frequency in CFR47 Pt 15 Restricted Band

PKFH - FHSS: RB=100k/1MHz VB=3 x RB, Peak

VA1T - FHSS: Linear Voltage Average VB=1/Ton where: Ton is transmit duration

HIGH CHANNEL RESULTS

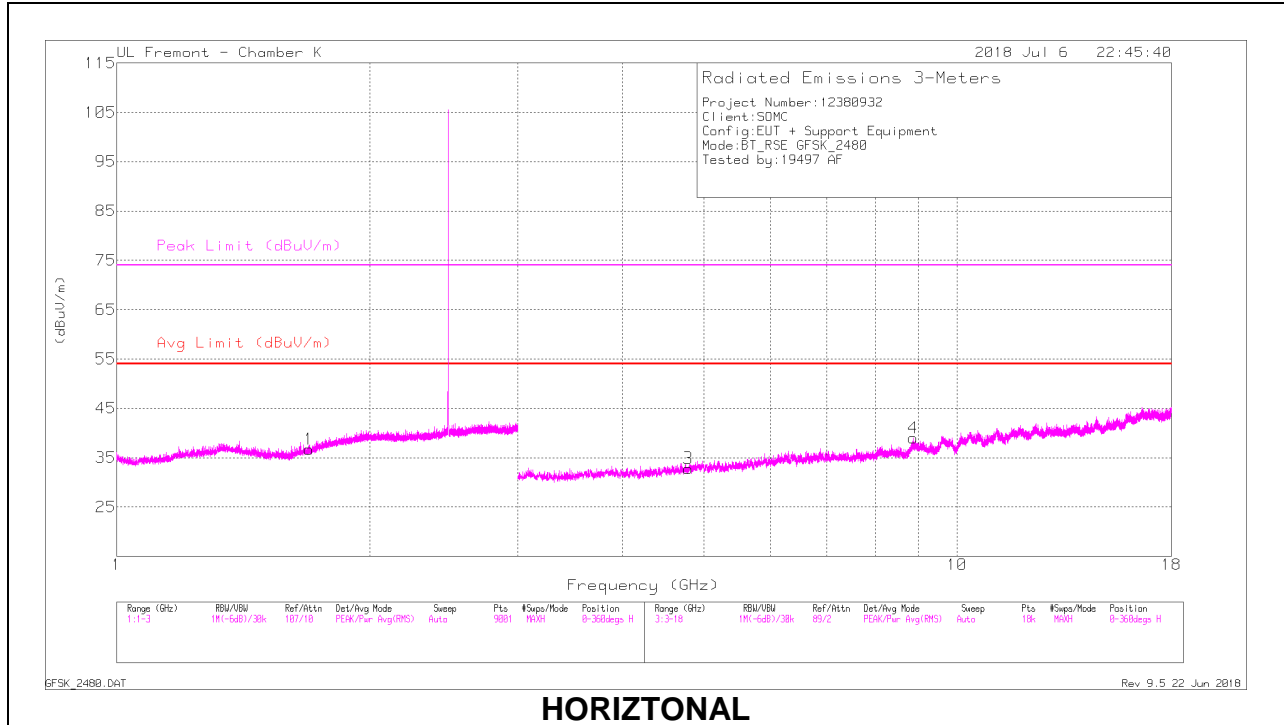

HORIZONTAL

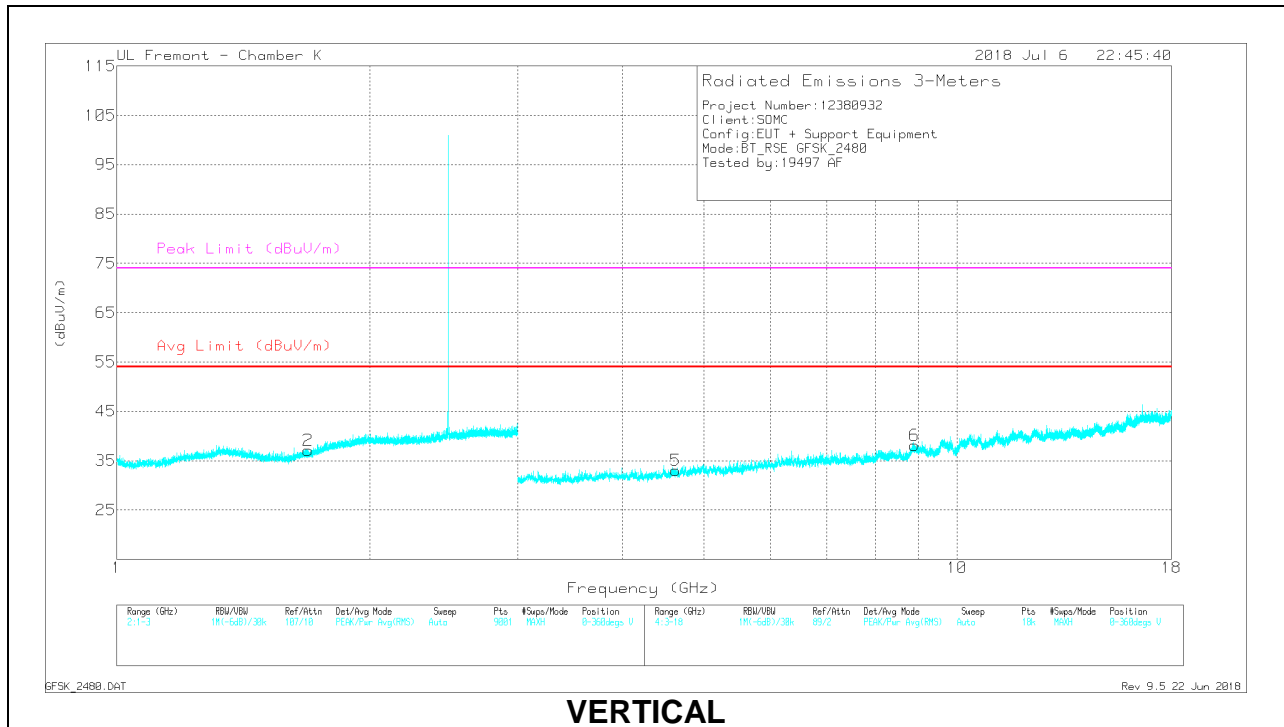

VERTICAL

RADIATED EMISSIONS

Radiated Emissions

Marker	Frequency (GHz)	Meter Reading (dBuV)	Det	AF T345 (dB/m)	Amp/Cb/Filtr/Pad (dB)	Corrected Reading (dBuV/m)	Avg Limit (dBuV/m)	Margin (dB)	Peak Limit (dBuV/m)	PK Margin (dB)	Azimuth (Degs)	Height (cm)	Polarity
1	* 1.692	40.54	PKFH	28.9	-24.1	45.34	-	-	74	-28.66	14	178	H
	* 1.693	27.35	VA1T	28.9	-24.1	32.15	54	-21.85	-	-	14	178	H
2	* 1.69	40.14	PKFH	28.9	-24.1	44.94	-	-	74	-29.06	56	379	V
	* 1.689	27.36	VA1T	28.9	-24.1	32.16	54	-21.84	-	-	56	379	V
3	* 4.792	35.98	PKFH	34.2	-28.8	41.38	-	-	74	-32.62	115	210	H
	* 4.793	22.89	VA1T	34.2	-28.8	28.29	54	-25.71	-	-	115	210	H
4	8.87	32.66	PKFH	36.2	-22	46.86	-	-	-	-	233	232	H
	8.873	18.85	VA1T	36.2	-22	33.05	-	-	-	-	233	232	H
5	* 4.629	36.42	PKFH	34	-29.3	41.12	-	-	74	-32.88	114	305	V
	* 4.625	23.58	VA1T	34	-29.3	28.28	54	-25.72	-	-	114	305	V
6	8.899	31.62	PKFH	36.2	-22.3	45.52	-	-	-	-	341	208	V
	8.9	19.15	VA1T	36.2	-22.3	33.05	-	-	-	-	341	208	V

* - indicates frequency in CFR47 Pt 15 Restricted Band

PKFH - FHSS: RB=100k/1MHz VB=3 x RB, Peak

VA1T - FHSS: Linear Voltage Average VB=1/Ton where: Ton is transmit duration

9.1.2. BLUETOOTH ENHANCED DATA RATE 8PSK MODULATION

BANDEDGE (LOW CHANNEL)

HORIZONTAL RESULT

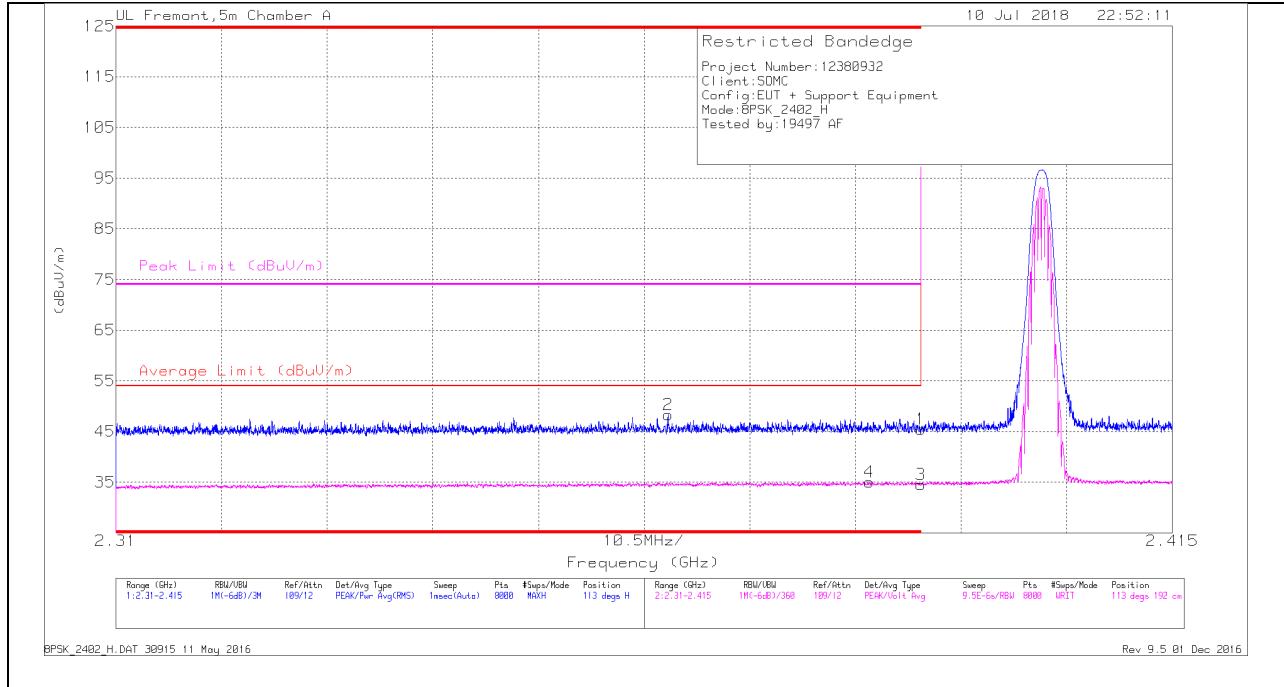

Trace Markers

Marker	Frequency (GHz)	Meter Reading (dBuV)	Det	AF T345 (dB/m)	Amp/Cbl/Filtr/Pad (dB)	Corrected Reading (dBuV/m)	Average Limit (dBuV/m)	Margin (dB)	Peak Limit (dBuV/m)	PK Margin (dB)	Azimuth (Degs)	Height (cm)	Polarity
1	* 2.39	36.62	Pk	31.8	-23	45.42	-	-	74	-28.58	113	192	H
2	* 2.365	39.66	Pk	31.6	-23	48.26	-	-	74	-25.74	113	192	H
3	* 2.39	25.67	VA1T	31.8	-23	34.47	54	-19.53	-	-	113	192	H
4	* 2.385	26.23	VA1T	31.8	-23	35.03	54	-18.97	-	-	113	192	H

* - indicates frequency in CFR47 Pt 15 Restricted Band

Pk - Peak detector

VA1T - FHSS: Linear Voltage Average $V_B=1/T_{on}$ where: T_{on} is transmit duration

VERTICAL RESULT

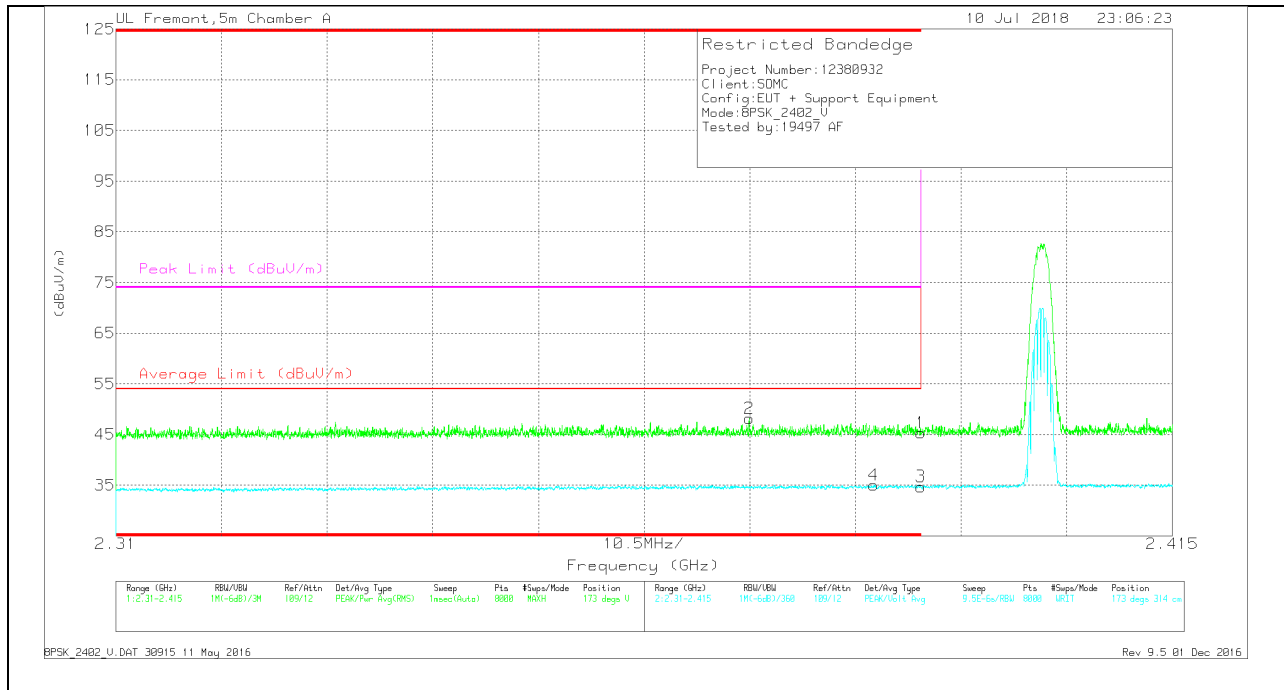

Trace Markers

Marker	Frequency (GHz)	Meter Reading (dBuV)	Det	AF T345 (dB/m)	Amp/Cb1/Filtr/Pad (dB)	Corrected Reading (dBuV/m)	Average Limit (dBuV/m)	Margin (dB)	Peak Limit (dBuV/m)	PK Margin (dB)	Azimuth (Degs)	Height (cm)	Polarity
1	* 2.39	36.5	Pk	31.8	-23	45.3	-	-	74	-28.7	173	314	V
2	* 2.373	39.49	Pk	31.7	-23	48.19	-	-	74	-25.81	173	314	V
3	* 2.39	25.91	VA1T	31.8	-23	34.71	54	-19.29	-	-	173	314	V
4	* 2.385	26.22	VA1T	31.8	-23	35.02	54	-18.98	-	-	173	314	V

* - indicates frequency in CFR47 Pt 15 Restricted Band

Pk - Peak detector

VA1T - FHSS: Linear Voltage Average VB=1/Ton where: Ton is transmit duration

BANDEDGE (HIGH CHANNEL)

HORIZONTAL RESULT

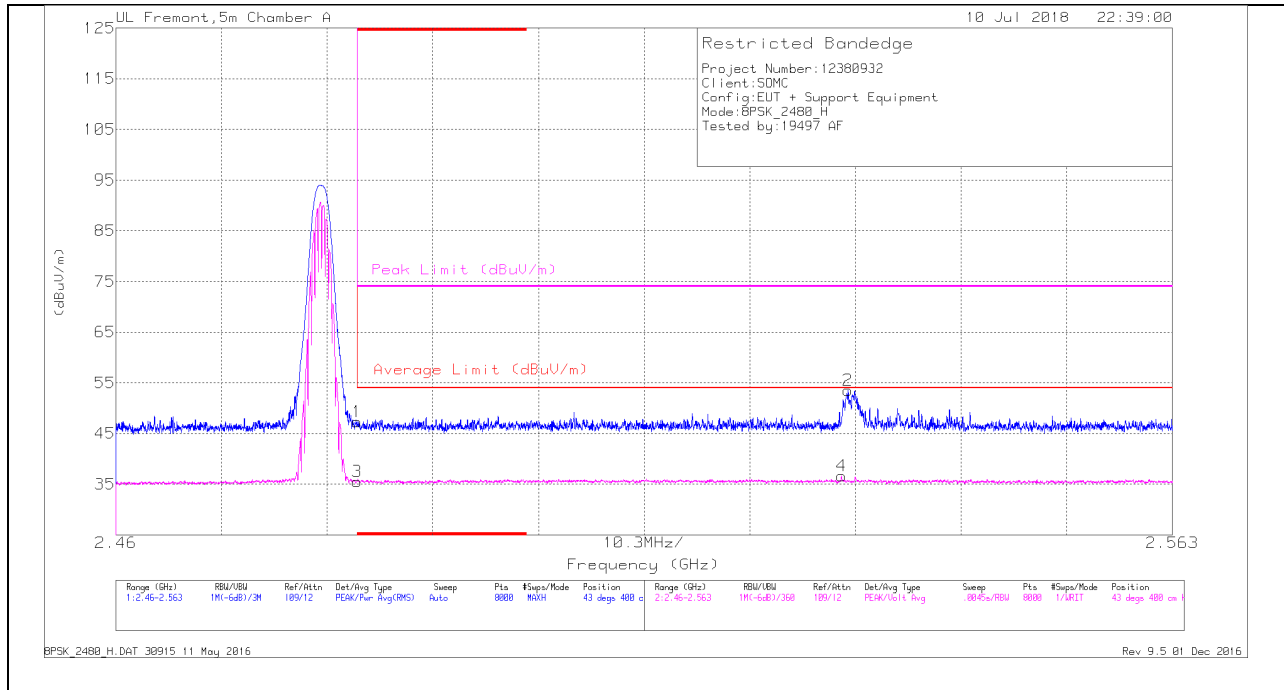

Trace Markers

Marker	Frequency (GHz)	Meter Reading (dBuV)	Det	AF T345 (dB/m)	Amp/Cbl/Filtr/Pad (dB)	Corrected Reading (dBuV/m)	Average Limit (dBuV/m)	Margin (dB)	Peak Limit (dBuV/m)	PK Margin (dB)	Azimuth (Degs)	Height (cm)	Polarity
1	* 2.484	37.86	Pk	32.3	-22.9	47.26	-	-	74	-26.74	43	400	H
3	* 2.484	26.09	VA1T	32.3	-22.9	35.49	54	-18.51	-	-	43	400	H
2	2.531	43.92	Pk	32.4	-22.8	53.52	-	-	74	-20.48	43	400	H
4	2.531	27.04	VA1T	32.4	-22.8	36.64	54	-17.36	-	-	43	400	H

* - indicates frequency in CFR47 Pt 15 Restricted Band

Pk - Peak detector

VA1T - FHSS: Linear Voltage Average VB=1/Ton where: Ton is transmit duration

VERTICAL RESULT

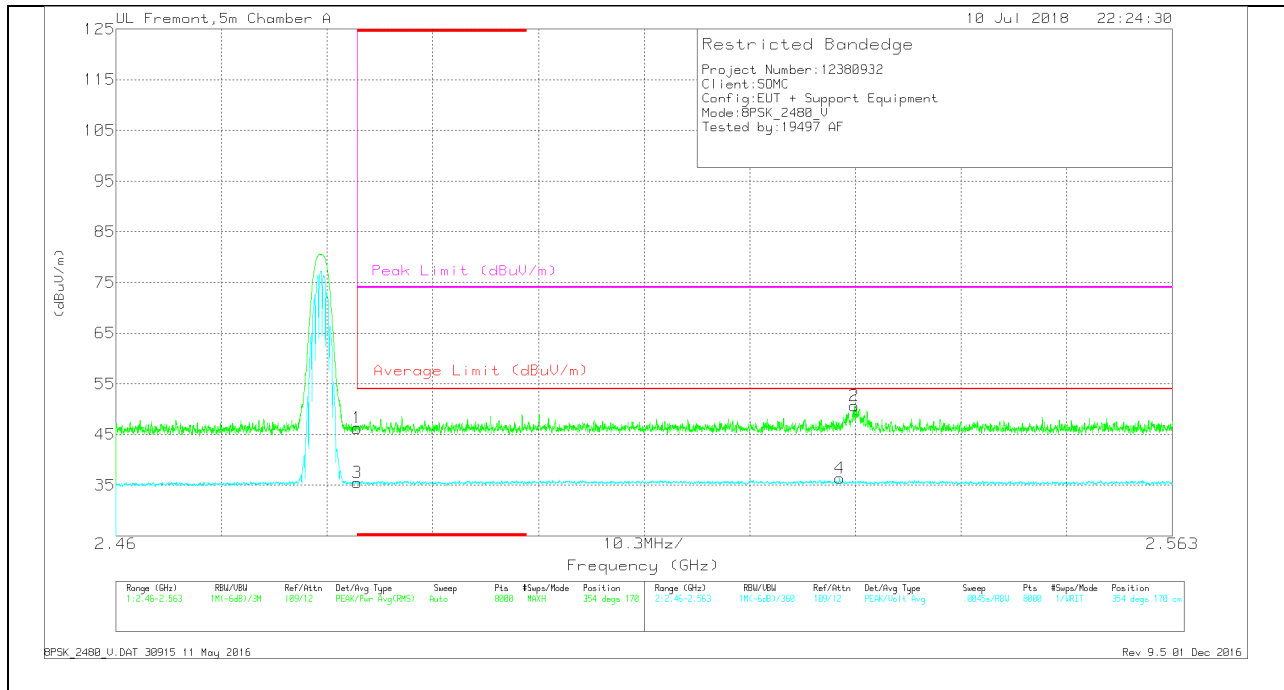

Trace Markers

Marker	Frequency (GHz)	Meter Reading (dBuV)	Det	AF T345 (dB/m)	Amp/Cbl/Filtr/Pad (dB)	Corrected Reading (dBuV/m)	Average Limit (dBuV/m)	Margin (dB)	Peak Limit (dBuV/m)	PK Margin (dB)	Azimuth (Degs)	Height (cm)	Polarity
1	* 2.484	36.86	Pk	32.3	-22.9	46.26	-	-	74	-27.74	354	170	V
3	* 2.484	26.09	VA1T	32.3	-22.9	35.49	54	-18.51	-	-	354	170	V
4	2.531	26.79	VA1T	32.4	-22.8	36.39	54	-17.61	-	-	354	170	V
2	2.532	41.09	Pk	32.4	-22.8	50.69	-	-	74	-23.31	354	170	V

* - indicates frequency in CFR47 Pt 15 Restricted Band

Pk - Peak detector

VA1T - FHSS: Linear Voltage Average $VB=1/Ton$ where: Ton is transmit duration

HARMONICS AND SPURIOUS EMISSIONS

LOW CHANNEL RESULTS

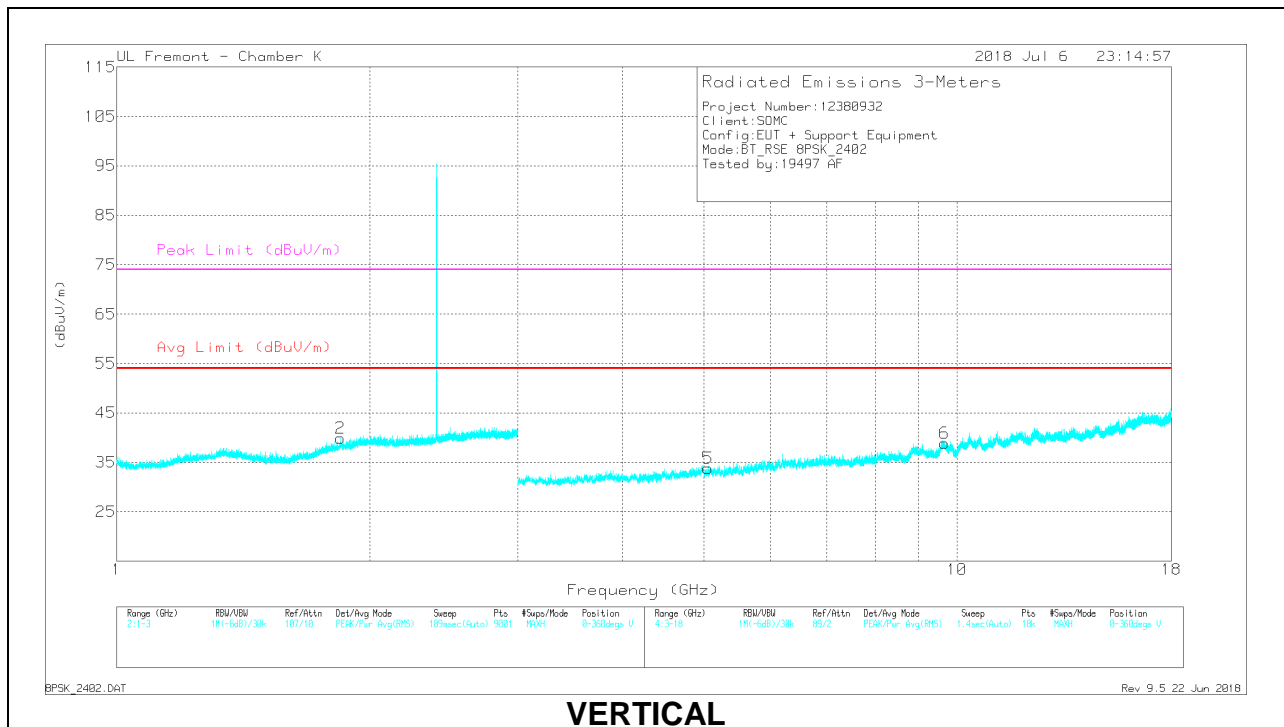
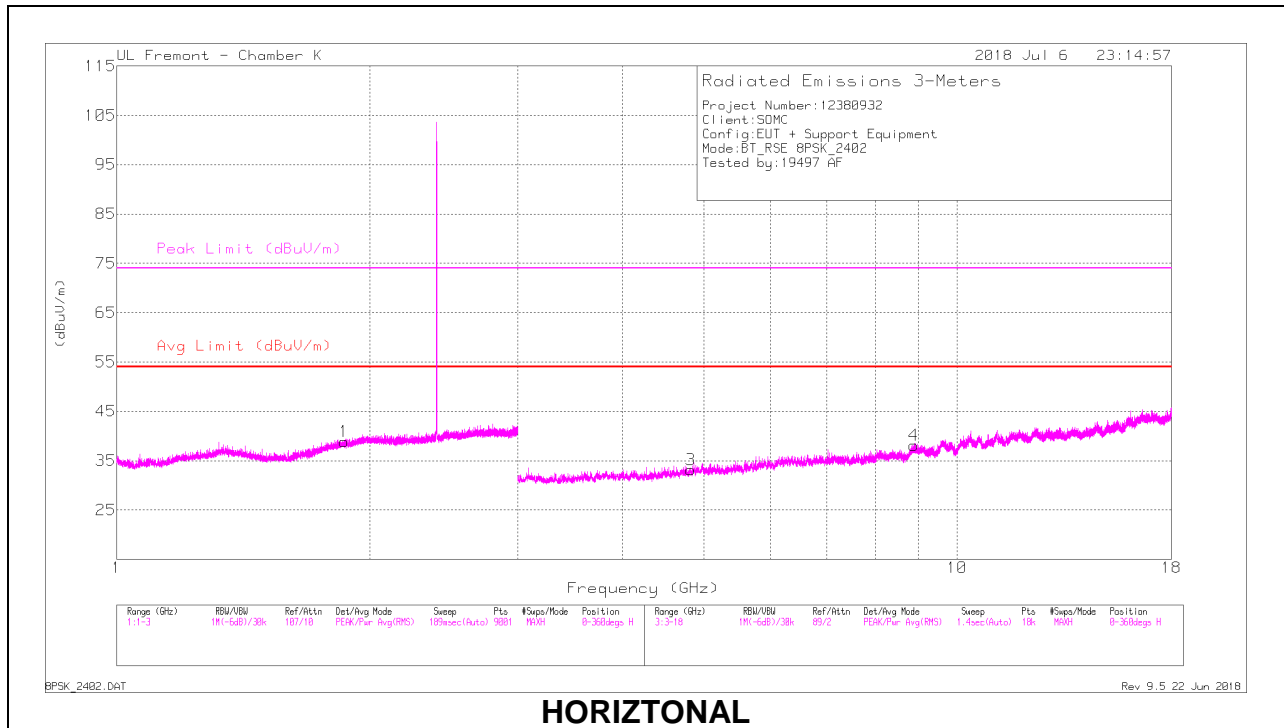

RADIATED EMISSIONS

Radiated Emissions

Marker	Frequency (GHz)	Meter Reading (dBuV)	Det	AF T345 (dB/m)	Amp/Cb/Filtr/Pad (dB)	Corrected Reading (dBuV/m)	Avg Limit (dBuV/m)	Margin (dB)	Peak Limit (dBuV/m)	PK Margin (dB)	Azimuth (Degs)	Height (cm)	Polarity
1	1.862	39.61	PKFH	30.9	-23.7	46.81	-	-	-	-	18	101	H
	1.864	27.09	VA1T	30.9	-23.7	34.29	-	-	-	-	18	101	H
2	1.848	39.67	PKFH	30.9	-23.8	46.77	-	-	-	-	162	194	V
	1.848	27.02	VA1T	30.8	-23.8	34.02	-	-	-	-	162	194	V
3	* 4.822	36.11	PKFH	34.2	-29	41.31	-	-	74	-32.69	89	329	H
	* 4.823	23.38	VA1T	34.2	-29	28.58	54	-25.42	-	-	89	329	H
4	8.882	30.83	PKFH	36.2	-22.2	44.83	-	-	-	-	316	170	H
	8.882	19.07	VA1T	36.2	-22.2	33.07	-	-	-	-	316	170	H
5	* 5.053	35.95	PKFH	34.4	-28.9	41.45	-	-	74	-32.55	183	133	V
	* 5.056	22.89	VA1T	34.4	-28.9	28.39	54	-25.61	-	-	183	133	V
6	9.67	30.49	PKFH	37	-21.2	46.29	-	-	-	-	24	164	V
	9.668	18.07	VA1T	37	-21.2	33.87	-	-	-	-	24	164	V

* - indicates frequency in CFR47 Pt 15 Restricted Band

PKFH - FHSS: RB=100k/1MHz VB=3 x RB, Peak

VA1T - FHSS: Linear Voltage Average VB=1/Ton where: Ton is transmit duration

MID CHANNEL RESULTS

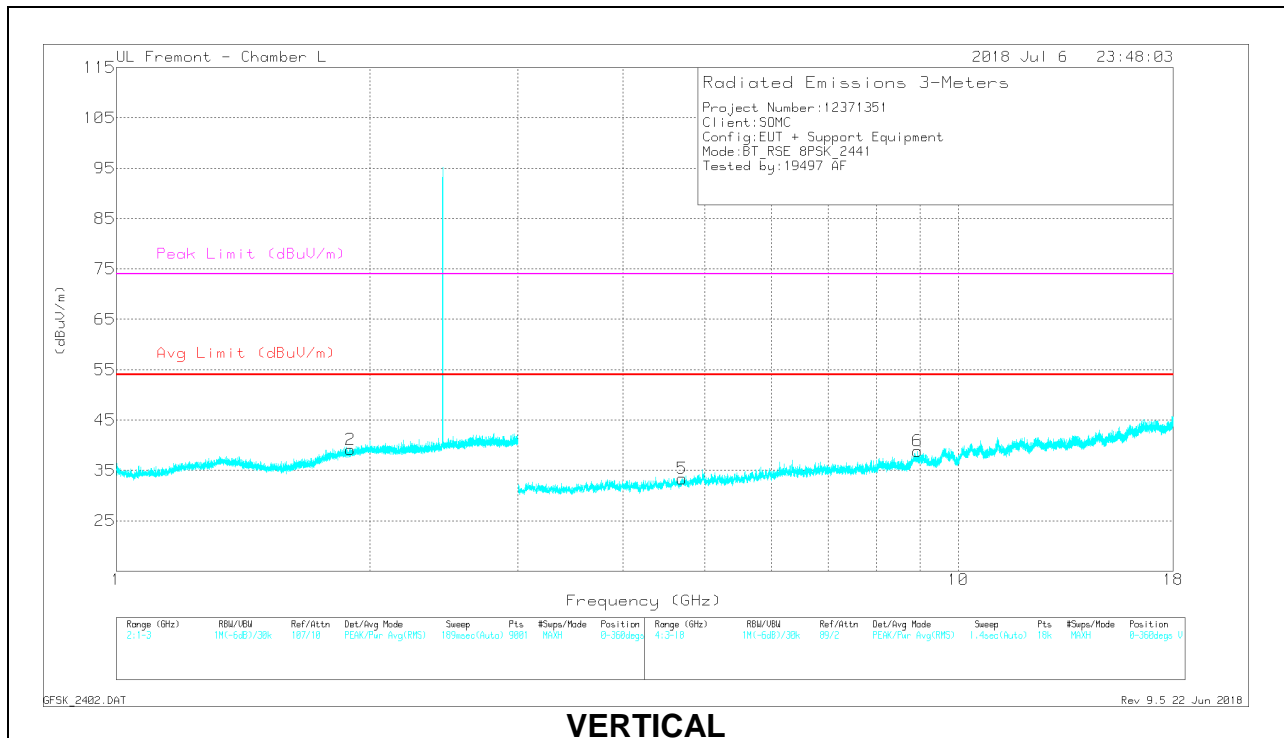
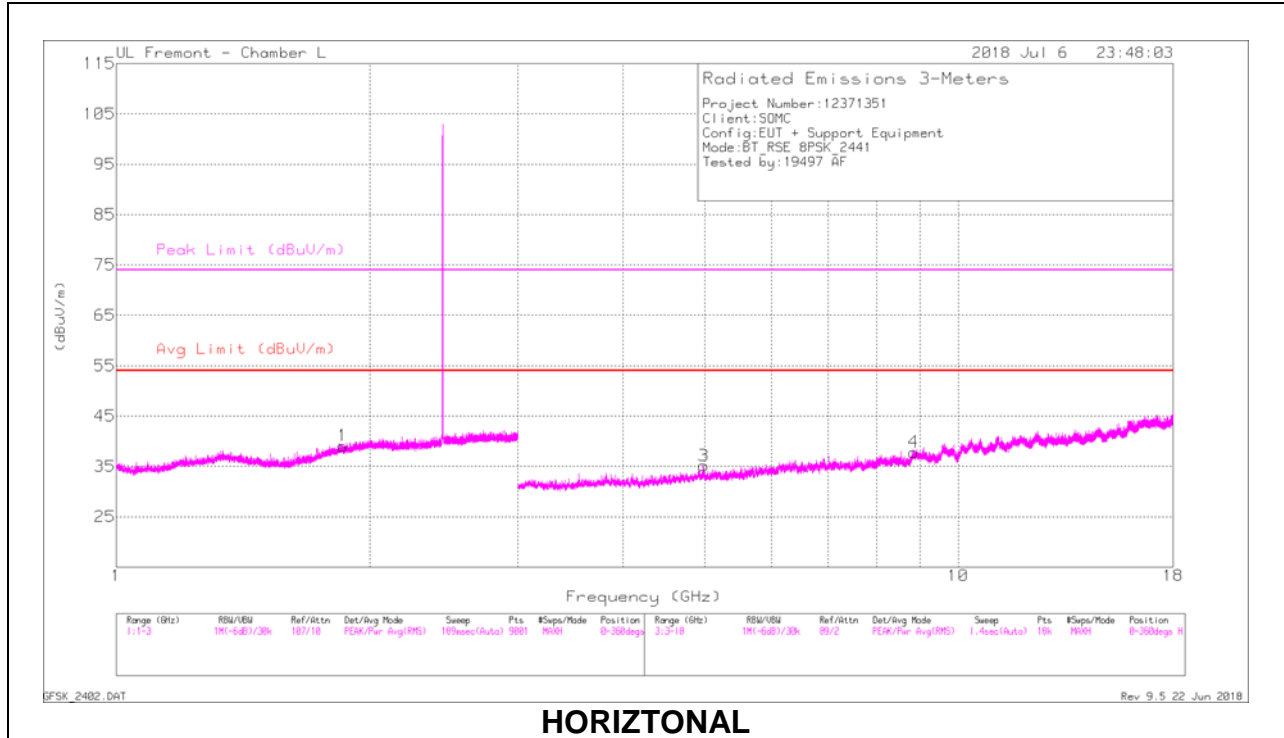

RADIATED EMISSIONS

Radiated Emissions

Marker	Frequency (GHz)	Meter Reading (dBuV)	Det	AF T345 (dB/m)	Amp/Cb/Filtr/Pad (dB)	Corrected Reading (dBuV/m)	Avg Limit (dBuV/m)	Margin (dB)	Peak Limit (dBuV/m)	PK Margin (dB)	Azimuth (Degs)	Height (cm)	Polarity
1	1.859	40.61	PKFH	30.9	-23.8	47.71	-	-	-	-	232	175	H
	1.857	27.13	VA1T	30.9	-23.8	34.23	-	-	-	-	232	175	H
2	1.899	38.95	PKFH	31	-23.7	46.25	-	-	-	-	222	159	V
	1.897	26.87	VA1T	31	-23.7	34.17	-	-	-	-	222	159	V
3	*4.987	35.09	PKFH	34.3	-28.1	41.29	-	-	74	-32.71	191	323	H
	*4.988	23.11	VA1T	34.3	-28.1	29.31	54	-24.69	-	-	191	323	H
4	8.856	31.5	PKFH	36.2	-21.8	45.9	-	-	-	-	313	321	H
	8.856	18.86	VA1T	36.2	-21.9	33.16	-	-	-	-	313	321	H
5	*4.701	35.17	PKFH	34	-28.6	40.57	-	-	74	-33.43	71	340	V
	*4.698	23.07	VA1T	34	-28.5	28.57	54	-25.43	-	-	71	340	V
6	8.948	32.72	PKFH	36.3	-22.8	46.22	-	-	-	-	90	224	V
	1.859	40.61	PKFH	30.9	-23.8	47.71	-	-	-	-	232	175	H

* - indicates frequency in CFR47 Pt 15 Restricted Band

PKFH - FHSS: RB=100k/1MHz VB=3 x RB, Peak

VA1T - FHSS: Linear Voltage Average VB=1/Ton where: Ton is transmit duration

HIGH CHANNEL RESULTS

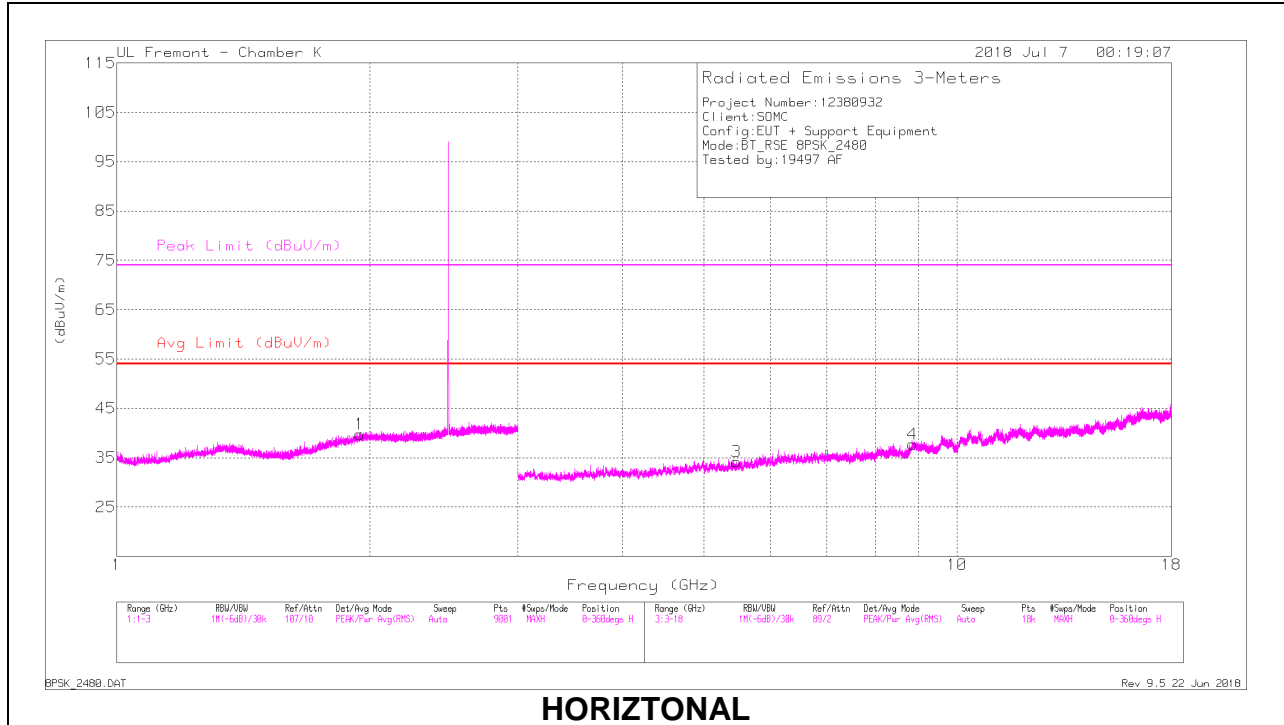

HORIZONTAL

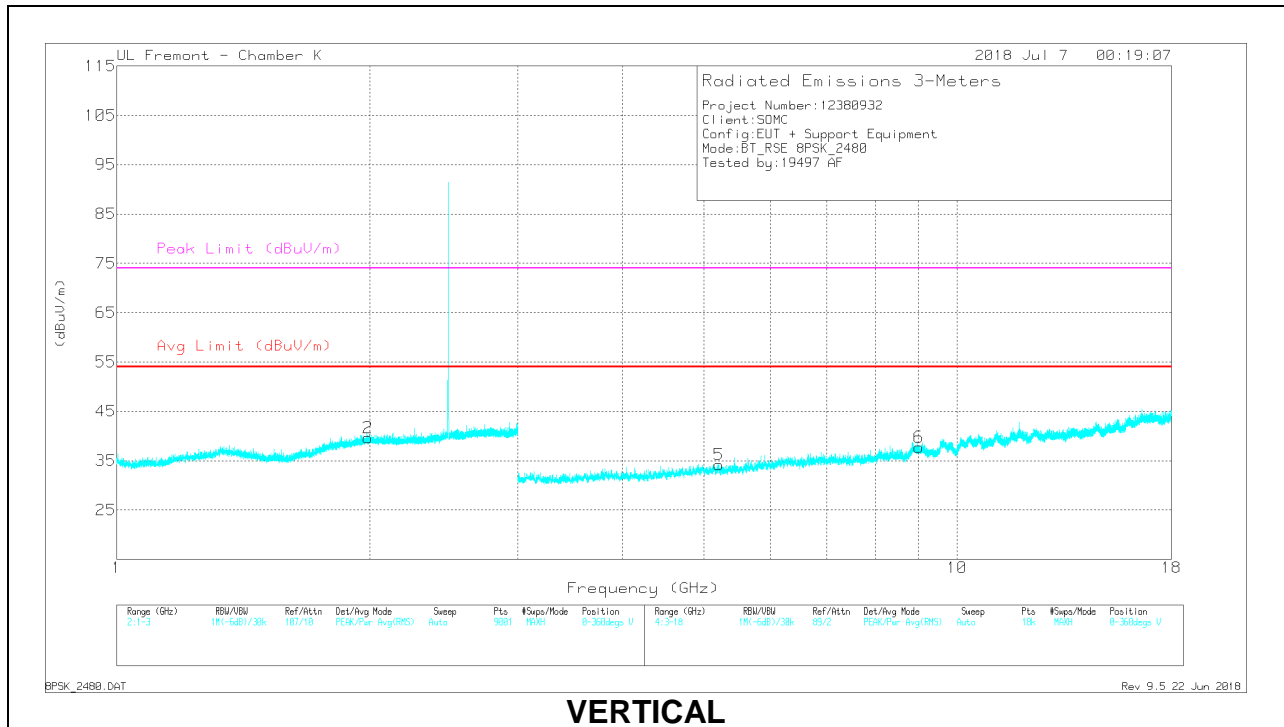

VERTICAL

RADIATED EMISSIONS

Radiated Emissions

Marker	Frequency (GHz)	Meter Reading (dBuV)	Det	AF T345 (dB/m)	Amp/Cb/Filtr/Pad (dB)	Corrected Reading (dBuV/m)	Avg Limit (dBuV/m)	Margin (dB)	Peak Limit (dBuV/m)	PK Margin (dB)	Azimuth (Degs)	Height (cm)	Polarity
1	1.945	40.17	PKFH	31.4	-23.6	47.97	-	-	-	-	86	229	H
	1.948	27.12	VA1T	31.4	-23.6	34.92	-	-	-	-	86	229	H
2	1.989	40.19	PKFH	31.6	-23.6	48.19	-	-	-	-	41	337	V
	1.989	26.99	VA1T	31.6	-23.6	34.99	-	-	-	-	41	337	V
3	5.461	34.74	PKFH	34.5	-27.4	41.84	-	-	-	-	310	182	H
	5.462	22.02	VA1T	34.5	-27.4	29.12	-	-	-	-	310	182	H
4	8.849	31.07	PKFH	36.2	-21.9	45.37	-	-	-	-	227	142	H
	8.851	18.73	VA1T	36.2	-21.9	33.03	-	-	-	-	227	142	H
5	5.207	35.39	PKFH	34.4	-27.8	41.99	-	-	-	-	328	274	V
	5.208	22.52	VA1T	34.4	-27.8	29.12	-	-	-	-	328	274	V
6	* 9.004	31.85	PKFH	36.3	-22.7	45.45	-	-	74	-28.55	111	282	V
	* 9.004	19.1	VA1T	36.3	-22.7	32.7	54	-21.3	-	-	111	282	V

* - indicates frequency in CFR47 Pt 15 Restricted Band

PKFH - FHSS: RB=100k/1MHz VB=3 x RB, Peak

VA1T - FHSS: Linear Voltage Average VB=1/Ton where: Ton is transmit duration

9.2. Worst Case Below 30 MHz

SPURIOUS EMISSIONS 9 kHz TO 30 MHz (WORST-CASE CONFIGURATION)

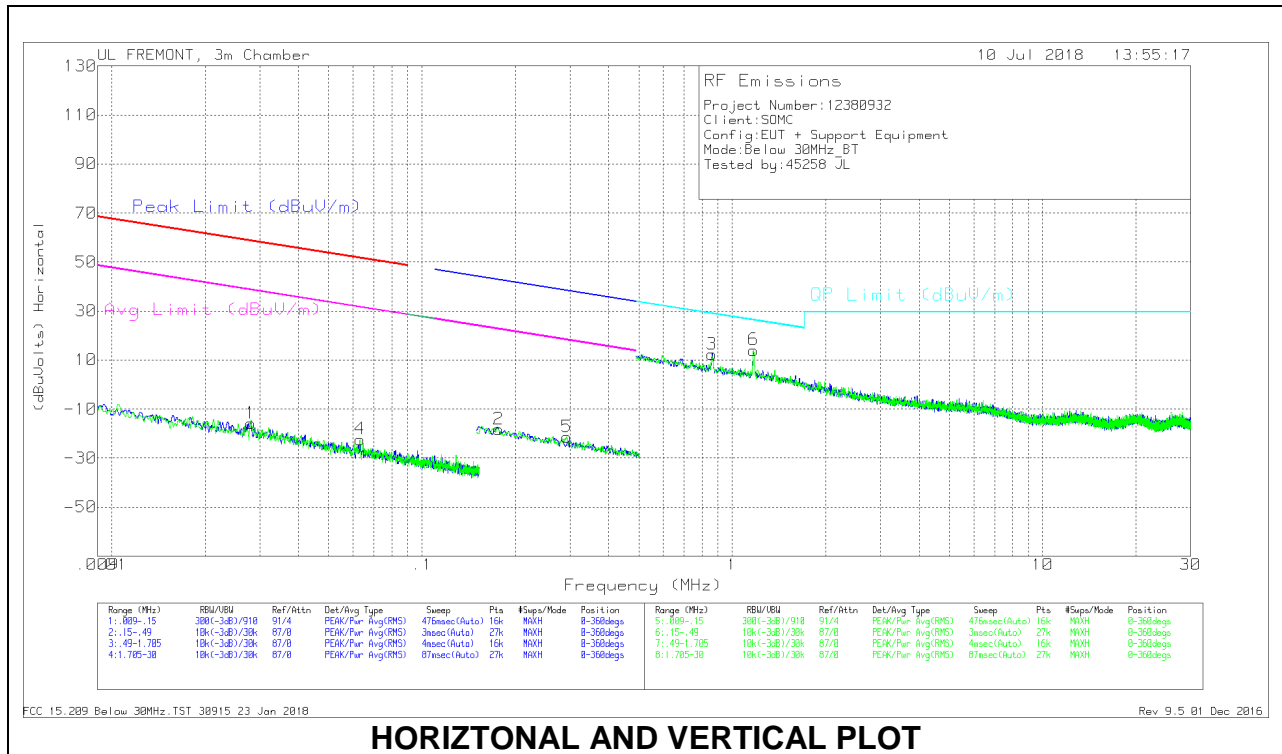

HORIZONTAL AND VERTICAL PLOT

Below 30 MHz Data

Trace Markers

Marker	Frequency (MHz)	Meter Reading (dBuV)	Det	Loop Antenna (dB/m)	Cbl (dB)	Dist Corr 300m	Corrected Reading (dBuVolts)	Peak Limit (dBuV/m)	Margin (dB)	Avg Limit (dBuV/m)	Margin (dB)	Peak Limit (dBuV/m)	Margin (dB)	Avg Limit (dBuV/m)	Margin (dB)	Azimuth (Degs)
1	.02811	47.78	Pk	15.1	1.4	-80	-15.72	58.61	-74.33	38.61	-54.33	-	-	-	-	0-360
4	.06316	42.06	Pk	14.2	1.4	-80	-22.34	51.58	-73.92	31.58	-53.92	-	-	-	-	0-360
2	.17657	46.37	Pk	13.8	1.5	-80	-18.33	-	-	-	-	42.68	-61.01	22.68	-41.01	0-360
5	.2931	43.45	Pk	13.7	1.5	-80	-21.35	-	-	-	-	38.27	-59.62	18.27	-39.62	0-360

Pk - Peak detector

Marker	Frequency (MHz)	Meter Reading (dBuV)	Det	Loop Antenna (dB/m)	Cbl (dB)	Dist Corr 30m	Corrected Reading (dBuVolts)	QP Limit (dBuV/m)	Margin (dB)	Peak Limit (dBuV/m)	Margin (dB)	Avg Limit (dBuV/m)	Margin (dB)	Azimuth (Degs)
3	.8602	36.93	Pk	14	1.5	-40	12.43	28.93	-16.5	-	-	-	-	0-360
6	1.17077	38.37	Pk	14.2	1.5	-40	14.07	26.26	-12.19	-	-	-	-	0-360

Pk - Peak detector

9.3. Worst Case Below 1 GHz

SPURIOUS EMISSIONS 30 TO 1000 MHz (WORST-CASE CONFIGURATION)

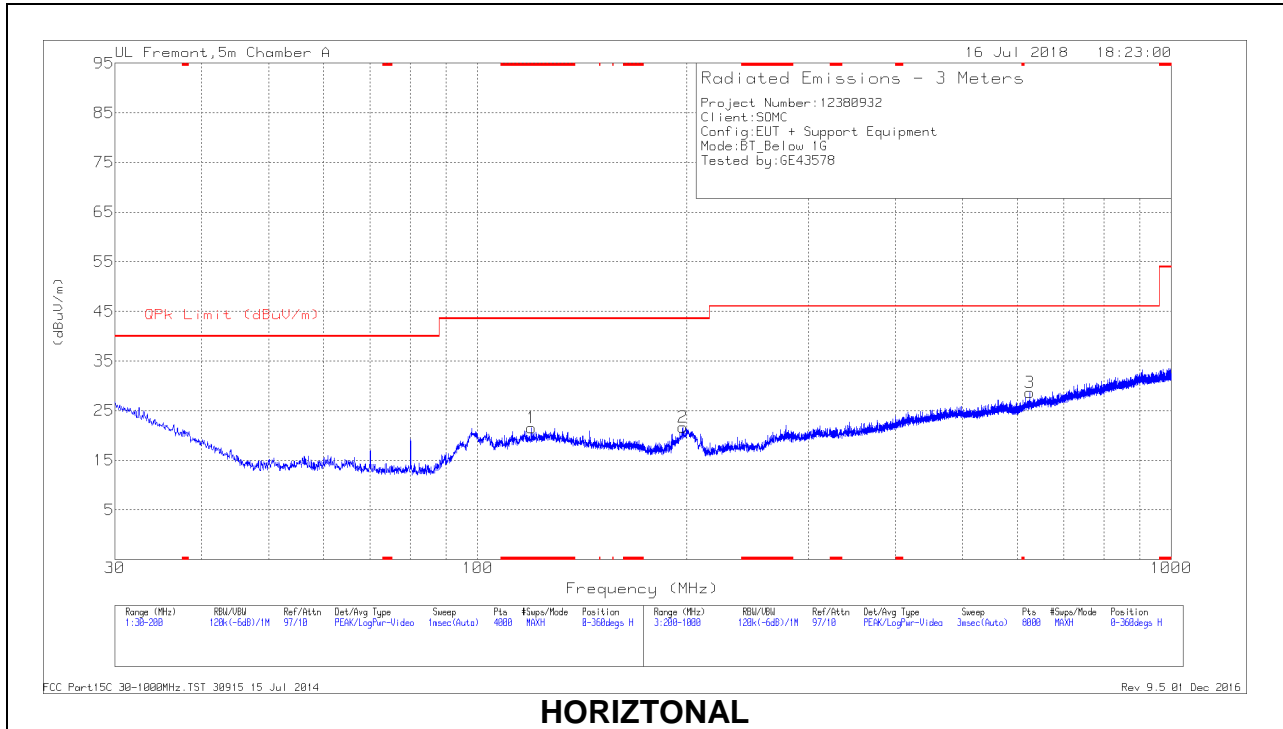

HORIZONTAL

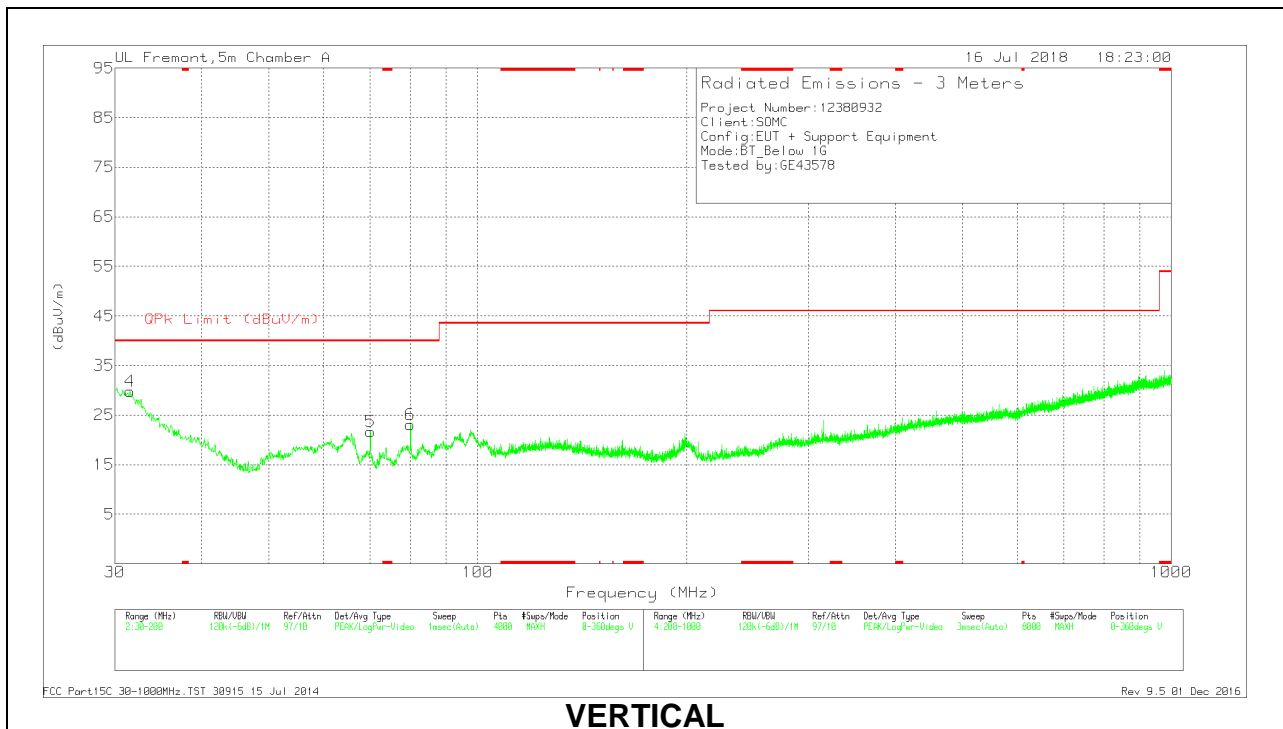

VERTICAL

Below 1GHz Data

Trace Markers

Marker	Frequency (MHz)	Meter Reading (dBuV)	Det	AFT130 (dB/m)	Amp/Cbl (dB/m)	Corrected Reading (dBuV/m)	QPk Limit (dBuV/m)	Margin (dB)	Azimuth (Degs)	Height (cm)	Polarity
1	* 119.5282	29.89	Pk	17.8	-26.2	21.49	43.52	-22.03	0-360	300	H
4	31.5304	33	Pk	24.1	-27.3	29.8	40	-10.2	0-360	100	V
5	70.0454	36.28	Pk	12.1	-26.7	21.68	40	-18.32	0-360	100	V
6	79.9929	38.18	Pk	11.5	-26.6	23.08	40	-16.92	0-360	100	V
2	197.8122	30.64	Pk	16.3	-25.3	21.64	43.52	-21.88	0-360	200	H
3	624.6552	30.21	Pk	23.3	-24.9	28.61	46.02	-17.41	0-360	101	H

* - indicates frequency in CFR47 Pt 15 Restricted Band

Pk - Peak detector

9.4. Worst Case 18-26 GHz

SPURIOUS EMISSIONS 18-26 GHz (WORST-CASE CONFIGURATION)

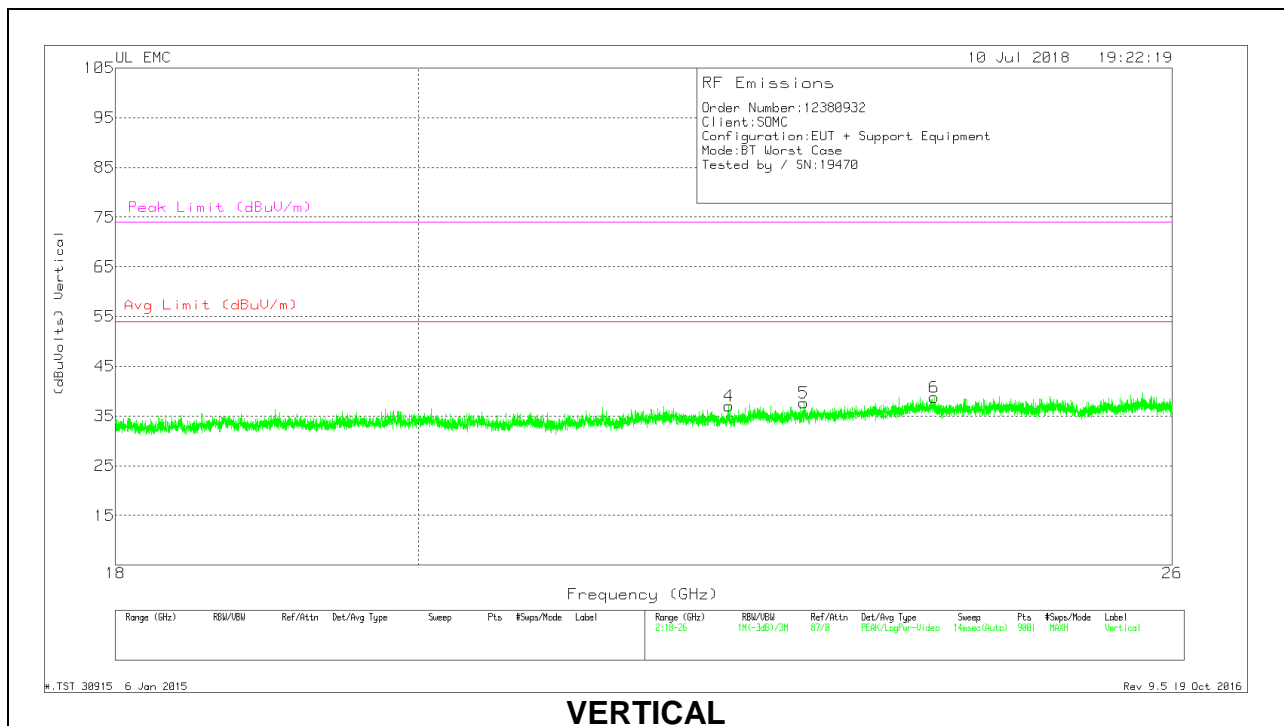
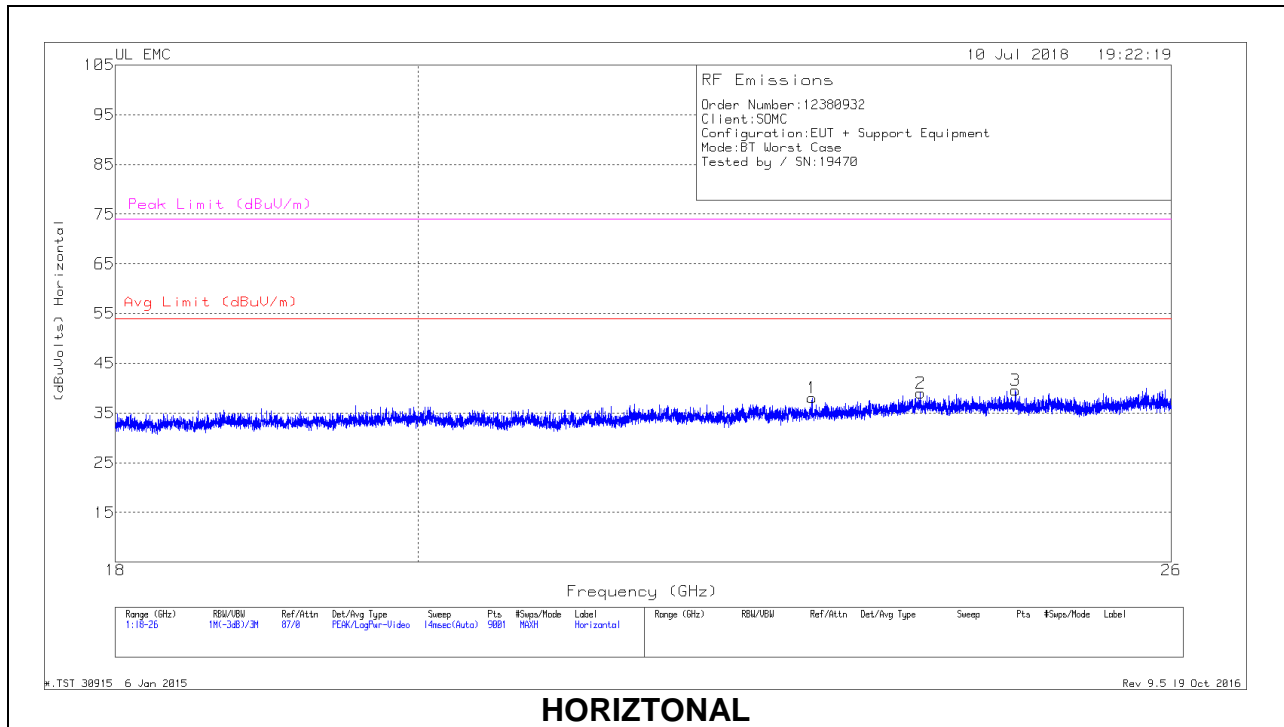

18 – 26GHz DATA

Trace Markers

Marker	Frequency (GHz)	Meter Reading (dBuV)	Det	T89 AF (dB/m)	Amp/Cbl (dB)	Dist Corr (dB)	Corrected Reading (dBuVolts)	Avg Limit (dBuV/m)	Margin (dB)	Peak Limit (dBuV/m)	PK Margin (dB)
1	22.942	39.02	Pk	33.5	-25	-9.5	38.02	54	-15.98	74	-35.98
2	23.825	39.01	Pk	33.6	-24.1	-9.5	39.01	54	-14.99	74	-34.99
3	24.626	39.37	Pk	33.9	-24.2	-9.5	39.57	54	-14.43	74	-34.43
4	22.282	38.36	Pk	32.8	-24.6	-9.5	37.06	54	-16.94	74	-36.94
5	22.873	38.75	Pk	33.4	-25	-9.5	37.65	54	-16.35	74	-36.35
6	23.932	38.94	Pk	33.4	-24.1	-9.5	38.74	54	-15.26	74	-35.26

Pk - Peak detector

10. AC POWER LINE CONDUCTED EMISSIONS

LIMITS

FCC §15.207 (a)

Frequency of Emission (MHz)	Conducted Limit (dBuV)	
	Quasi-peak	Average
0.15-0.5	66 to 56*	56 to 46*
0.5-5	56	46
5-30	60	50

*Decreases with the logarithm of the frequency.

TEST PROCEDURE

The EUT is placed on a non-conducting table 40 cm from the vertical ground plane and 80 cm above the horizontal ground plane. The EUT is configured in accordance with ANSI C63.4.

The receiver is set to a resolution bandwidth of 9 kHz. Peak detection is used unless otherwise noted as quasi-peak or average.

Line conducted data is recorded for both NEUTRAL and HOT lines.

RESULTS

10.1.1. AC Power Line Norm

LINE 1 RESULTS

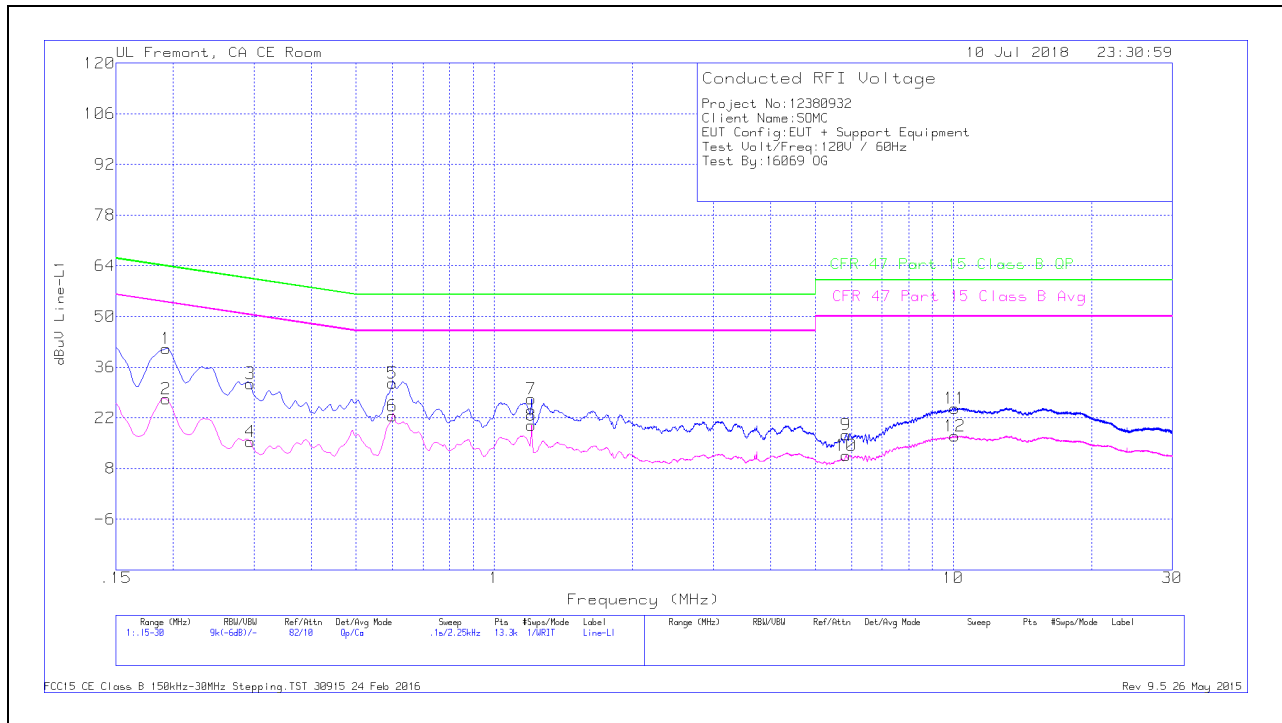

Trace Markers

Range 1: Line-L1 .15 - 30MHz											
Marker	Frequency (MHz)	Meter Reading (dBuV)	Det	LISN L1	LC Cables C1&C3	Limiter (dB)	Corrected Reading dBuV	CFR 47 Part 15 Class B QP	QP Margin (dB)	CFR 47 Part 15 Class B Avg	Av(CISPR) Margin (dB)
1	.19275	31.09	Qp	0	0	10.1	41.19	63.92	-22.73	-	-
2	.19275	17.11	Ca	0	0	10.1	27.21	-	-	53.92	-26.71
3	.294	21.38	Qp	0	0	10.1	31.48	60.41	-28.93	-	-
4	.294	5.29	Ca	0	0	10.1	15.39	-	-	50.41	-35.02
5	.6	21.44	Qp	0	0	10.1	31.54	56	-24.46	-	-
6	.6	12.47	Ca	0	0	10.1	22.57	-	-	46	-23.43
7	1.20525	17.04	Qp	0	.1	10.1	27.24	56	-28.76	-	-
8	1.20525	9.71	Ca	0	.1	10.1	19.91	-	-	46	-26.09
9	5.84025	6.86	Qp	0	.2	10.2	17.26	60	-42.74	-	-
10	5.84025	1.18	Ca	0	.2	10.2	11.58	-	-	50	-38.42
11	10.077	14.23	Qp	0	.2	10.2	24.63	60	-35.37	-	-
12	10.077	6.61	Ca	0	.2	10.2	17.01	-	-	50	-32.99

Qp - Quasi-Peak detector
 Ca - CISPR average detection

LINE 2 RESULTS

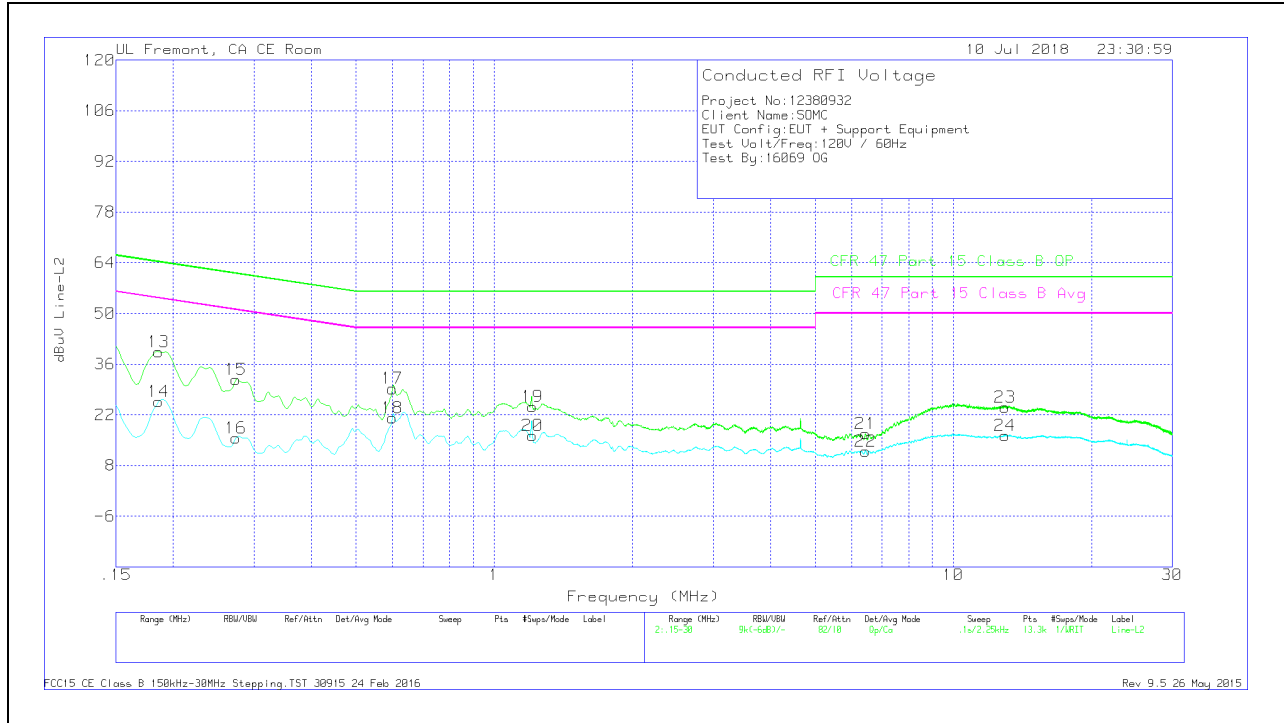

Trace Markers

Range 2: Line-L2 .15 - 30MHz											
Marker	Frequency (MHz)	Meter Reading (dBuV)	Det	LISN L2	LC Cables C2&C3	Limiter (dB)	Corrected Reading dBuV	CFR 47 Part 15 Class B QP	QP Margin (dB)	CFR 47 Part 15 Class B Avg	Av(CISPR) Margin (dB)
13	.186	29.27	Qp	0	0	10.1	39.37	64.21	-24.84	-	-
14	.186	15.49	Ca	0	0	10.1	25.59	-	-	54.21	-28.62
15	.27375	21.61	Qp	0	0	10.1	31.71	61	-29.29	-	-
16	.27375	5.43	Ca	0	0	10.1	15.53	-	-	51	-35.47
17	.6	19.13	Qp	0	0	10.1	29.23	56	-26.77	-	-
18	.6	11.12	Ca	0	0	10.1	21.22	-	-	46	-24.78
19	1.212	14.15	Qp	0	.1	10.1	24.35	56	-31.65	-	-
20	1.212	6.08	Ca	0	.1	10.1	16.28	-	-	46	-29.72
21	6.441	6.34	Qp	0	.2	10.2	16.74	60	-43.26	-	-
22	6.441	1.53	Ca	0	.2	10.2	11.93	-	-	50	-38.07
23	12.966	13.56	Qp	.1	.2	10.2	24.06	60	-35.94	-	-
24	12.966	5.8	Ca	.1	.2	10.2	16.3	-	-	50	-33.7

Qp - Quasi-Peak detector
 Ca - CISPR average detection