

FCC TEST REPORT

according to

FCC Rules and Regulations

Part 15 Subpart C

Applicant	Netgear Inc..
Address	4500 Great America Parkway Santa Clara California 95054 USA
Equipment	54 Mbps Wireless Powerline Access Point
Model No.	WGX102
FCC ID	PY3WGX102
Trade Name	Netgear

- The test result refers exclusively to the test presented test model / sample.,
- Without written approval of *Exclusive Certification Corp.* the test report shall not be reproduced except in full.

Contents

1.	Report of Measurements and Examinations.....	4
1.1.	List of Measurements and Examinations	4
1.2.	Antenna Requirements.....	5
1.3.	Test of Conducted Emission	6
1.4.	Test of Radiated Emission.....	8
1.5.	6dB Bandwidth.....	9
1.6.	Maximum Peak Output Power	9
1.7.	Band Edges Measurement	10
1.8.	Power Spectral Density	10
1.9.	Restricted Bands of Operation.....	11
1.10.	Labeling Requirement	11
1.11.	RF Exposure	12
2.	Test Configuration of Equipment under Test.....	14
2.1.	Test Mode and Test Software.....	14
2.2.	Description of Test System	14
2.3.	Connection Diagram of Test System	15
2.4.	Feature of Equipment under Test	15
2.5.	History of this test report	15
3.	General Information of Test	16
4.	Test Result and Data.....	17
4.1.	Antenna Requirement	17
4.2.	Test Result of Conducted Emission	18
4.3.	RF Portion.....	31
4.4.	6dB Bandwidth Measurement Data.....	41
4.5.	Peak Output Power Measurement Data	45
4.6.	Band Edges Measurement Data	49
4.7.	Power Spectral Density Measurement Data.....	61
4.8.	Test Result of RF Exposure Evaluation.....	65
5.	List of Measuring Equipment Used.....	66
	Appendix A. Photographs of EUT.....	A1 ~ A7

CERTIFICATE OF COMPLIANCE

according to

FCC Rules and Regulations

Part 15 Subpart C

Applicant	Netgear Inc..
Address	4500 Great America Parkway Santa Clara California 95054 USA
Equipment	54 Mbps Wireless Powerline Access Point
Model No.	WGX102
FCC ID	PY3WGX102

I HEREBY CERTIFY THAT :

The measurements shown in this test report were made in accordance with the procedures given in **ANSI C63.4**. The equipment was **passed** the test performed according to **FCC Rules and Regulations Part 15 Subpart C (2002)**. The test was carried out on Aug. 15, 2004 at *Exclusive Certification Corp.*

Signature

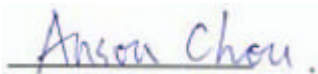

Anson Chou / Manager

1. Report of Measurements and Examinations

1.1. List of Measurements and Examinations

FCC Rule	Description of Test	Result
15.203	. Antenna Requirement	Pass
15.207	. Conducted Emission	Pass
15.209	. Radiated Emission	Pass
15.247(a)(2)	. 6dB Bandwidth	Pass
15.247(b)	. Maximum Peak Output Power	Pass
15.247(c)	. 100kHz Bandwidth of Frequency Band Edges	Pass
15.247(d)	. Power Spectral Density	Pass
1.1307 1.1310 2.1091 2.1093	. RF Exposure Compliance	Pass

Test by:

Jerry

1.2. Antenna Requirements

1.2.1. Standard Applicable

For intentional device, according to FCC 47 CFR Section 15.203, an intentional radiator shall be designed to ensure that no antenna other than that furnished by the responsible party shall be used with the device.

And according to FCC 47 CFR Section 15.247 (b), if transmitting antennas of directional gain greater than 6dBi are used, the power shall be reduced by the amount in dB that the directional gain of the antenna exceeds 6dBi.

1.3. Test of Conducted Emission

Conducted Emissions were measured from 150 kHz to 30 MHz with a bandwidth of 9 KHz on the 115 VAC power and return leads of the EUT according to the methods defined in ANSI C63.4-1992 Section 3.1. The EUT was placed on a nonmetallic stand in a shielded room 0.8 meters above the ground plane as shown in section 2.2. The interface cables and equipment positioning were varied within limits of reasonable applications to determine the position produced maximum conducted emissions.

1.3.1. Test Procedures

- a. The EUT was placed 0.4 meter from the conducting wall of the shielding room was kept at least 80 centimeters from any other grounded conducting surface.
- b. Connect EUT to the power mains through a line impedance stabilization network (LISN).
- c. All the support units are connecting to the other LISN.
- d. The LISN provides 50 ohm coupling impedance for the measuring instrument.
- e. The FCC states that a 50 ohm, 50 microhenry LISN should be used.
- f. Both sides of AC line were checked for maximum conducted interference.
- g. The frequency range from 150 kHz to 30 MHz was searched.
- h. Set the test-receiver system to Peak Detect Function and Specified Bandwidth with Maximum Hold Mode.

1.3.2. Typical Test Setup Layout of Conducted Emission

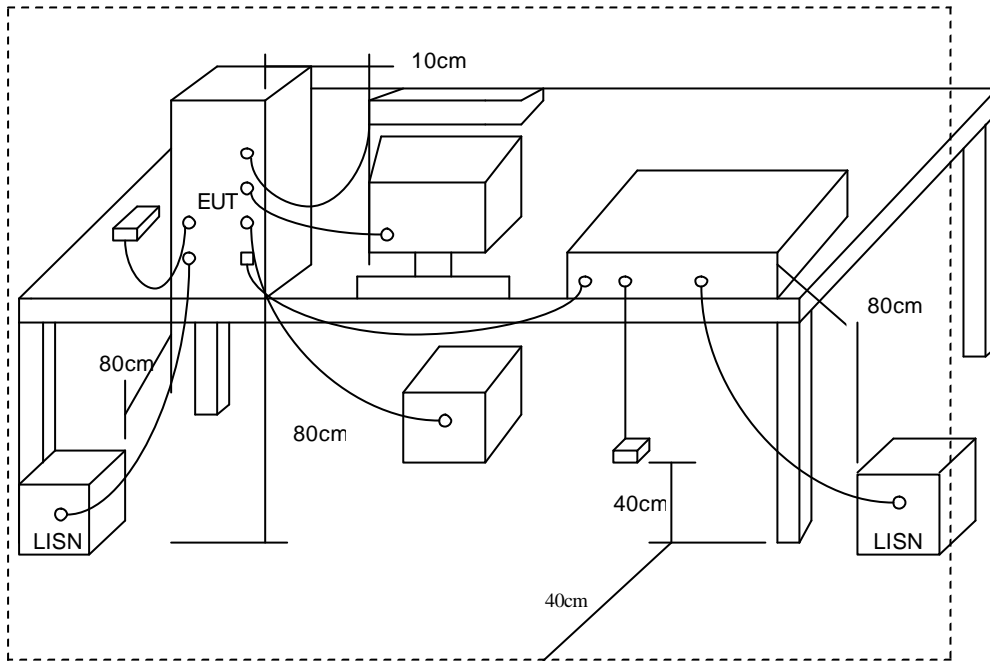

1.3.3. Conducted Emission Requirement

Except for A digital devices, for equipment that is designed to be connected to the public utility (AC) power line on any frequency voltage that is conducted back onto the AC power line on ant frequency or frequencies within the band 150KHz to 30MHz shall not exceed the limits in the following table, as measured using a 50μH/50 ohms line impedance stabilization network (LISN). Compliance with the provisions of this paragraph shall be based on the measurement of the Radio frequency voltage between each power line and ground at the power terminal. The lower limit applies at the band edges.

Frequency (MHz)	Quasi Peak (dB μ V)	Average (dB μ V)
0.15 – 0.5	66-56*	56-46*
0.5 – 5.0	56	46
5.0 – 30.0	60	50

1.4. Test of Radiated Emission

Radiated emissions from 30 MHz to 25 GHz were measured according to the methods defines in ANSI C63.4-2001. The EUT was placed, 0.8 meter above the ground plane, as shown in section 5.6.3. The interface cables and equipment positions were varied within limits of reasonable applications to determine the positions producing maximum radiated emissions

1.4.1. Test Procedures

1. The EUT was placed on a rotatable table top 0.8 meter above ground.
2. The EUT was set 3 meters from the interference receiving antenna which was mounted on the top of a variable height antenna tower.
3. The table was rotated 360 degrees to determine the position of the highest radiation.
4. The antenna is a broadband antenna and its height is varied between one meter and four meters above ground to find the maximum value of the field strength both horizontal polarization and vertical polarization of the antenna are set to make the measurement.
5. For each suspected emission the EUT was arranged to its worst case and then tune the antenna tower (from 1 M to 4 M) and turn table (from 0 degree to 360 degrees) to find the maximum reading.
6. Set the test-receiver system to Peak or CISPR quasi-peak Detect Function and specified bandwidth with Maximum Hold Mode.
7. If the emission level of the EUT in peak mode was 3 dB lower than the limit specified, then testing will be stopped and peak values of EUT will be reported, otherwise, the emissions which do not have 3 dB margin will be repeated one by one using the quasi-peak method and reported.
8. For testing above 1GHz, the emission level of the EUT in peak mode was 20dB lower than average limit (that means the emission level in peak mode also complies with the limit in average mode), then testing will be stopped and peak values of EUT will be reported, otherwise, the emissions will be measured in average mode again and reported.

1.4.2. Typical Test Setup Layout of Radiated Emission

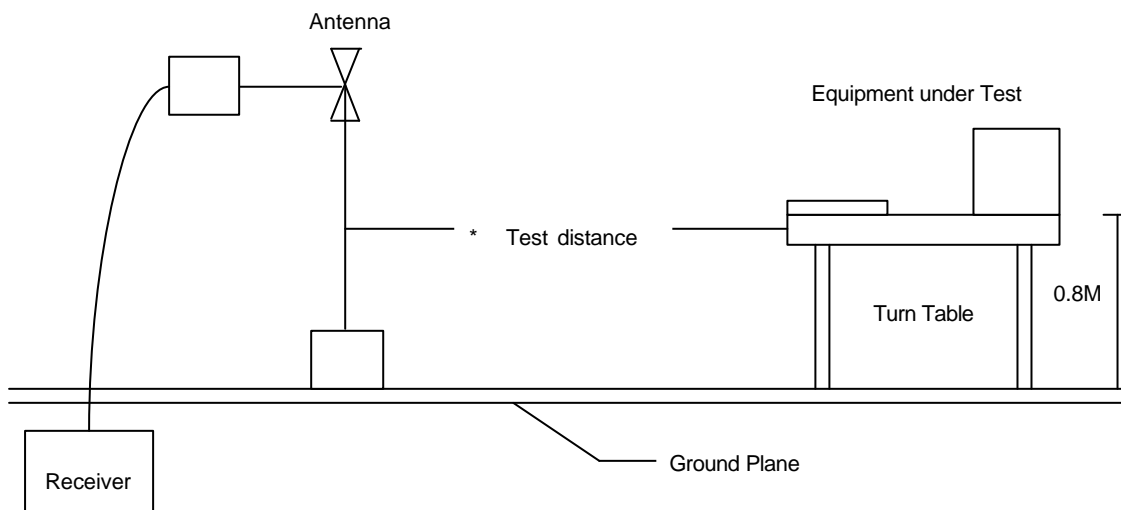

1.5. 6dB Bandwidth

1.5.1. Test Procedure :

1. The transmitter output was connected to the spectrum analyzer.
2. Set RBW of spectrum analyzer to 100 KHz and VBW to 100 KHz.
3. The 6 dB bandwidth is defined as the total spectrum the power of which is higher than peak power minus 6 dB.

1.5.2. Test Setup Layout :

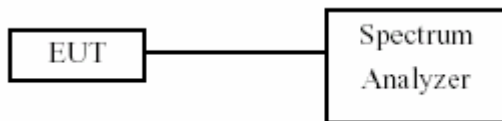

1.6. Maximum Peak Output Power

1.6.1. Test Procedure :

The antenna port (RF output) of the EUT was connected to the input (RF input) of a spectrum analyzer. Power was read directly from the spectrum analyzer and cable loss connection was added to the reading to obtain power at the EUT antenna terminal. The EUT Output Power was set to maximum to produce the worse case test result.

1.6.2. Test Setup Layout :

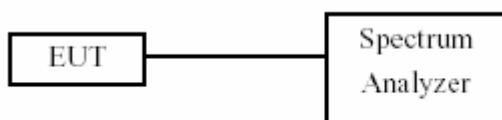

1.7. Band Edges Measurement

1.7.1. Test Procedure :

1. The transmitter output was connected to the spectrum analyzer via a low lose cable.
2. Set both RBW and VBW of spectrum analyzer to 100 KHz with convenient frequency span including 100 MHz bandwidth from band edge.
3. The band edges was measured and recorded.

1.8. Power Spectral Density

1.8.1. Test Procedure :

1. The transmitter output was connected to spectrum analyzer.
2. The spectrum analyzer' s resolution bandwidth were set at 3KHz RBW and 30KHz VBW as that of the fundamental frequency. Set the sweep time= $\text{span}/3\text{KHz}$.
3. The power spectral density was measured and recorded.
4. The Sweep time is allowed to be longer than $\text{span}/3\text{KHz}$ for a full response of the mixer in the spectrum analyzer.

1.8.2. Test Setup Layout :

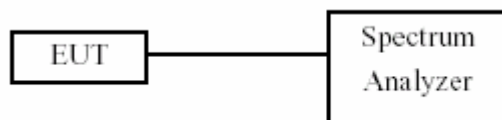

1.9. Restricted Bands of Operation

Only spurious emissions are permitted in any of the frequency bands listed below:

MHz	MHz	MHz	GHz
0.09000 – 0.11000	16.42000 – 16.42300	399.9 – 410.0	4.500 – 5.250
0.49500 – 0.505**	16.69475 – 16.69525	608.0 – 614.0	5.350 – 5.460
2.17350 – 2.19050	16.80425 – 16.80475	960.0 – 1240.0	7.250 – 7.750
4.12500 – 4.12800	25.50000 – 25.67000	1300.0 – 1427.0	8.025 – 8.500
4.17725 – 4.17775	37.50000 – 38.25000	1435.0 – 1626.5	9.000 – 9.200
4.20725 – 4.20775	73.00000 – 74.60000	1645.5 – 1646.5	9.300 – 9.500
6.21500 – 6.21800	74.80000 – 75.20000	1660.0 – 1710.0	10.600 – 12.700
6.26775 – 6.26825	108.00000 – 121.94000	1718.8 – 1722.2	13.250 – 13.400
6.31175 – 6.31225	123.00000 – 138.00000	2200.0 – 2300.0	14.470 – 14.500
8.29100 – 8.29400	149.90000 – 150.05000	2310.0 – 2390.0	15.350 – 16.200
8.36200 – 8.36600	156.52475 – 156.52525	2483.5 – 2500.0	17.700 – 21.400
8.37625 – 8.38675	156.70000 – 156.90000	2655.0 – 2900.0	22.010 – 23.120
8.41425 – 8.41475	162.01250 – 167.17000	3260.0 – 3267.0	23.600 – 24.000
12.29000 – 12.29300	167.72000 – 173.20000	3332.0 – 3339.0	31.200 – 31.800
12.51975 – 12.52025	240.00000 – 285.00000	3345.8 – 3358.0	36.430 – 36.500
12.57675 – 12.57725	322.00000 – 335.40000	3600.0 – 4400.0	Above 38.6
13.36000 – 13.41000			

** : Until February 1, 1999, this restricted band shall be 0.490-0.510 MHz

1.10. Labeling Requirement

The device shall bear the following statement in a conspicuous location on the device:

This device complies with part 15 of the FCC Rules. Operation is subject to the following two conditions: (1) This device may not cause harmful interference, and (2) this device must accept any interference received, including interference that may cause undesired operation.

1.11. RF Exposure

FCC Rules and Regulations Part 1.1307, 1.1310, 2.1091, 2.1093:

RF Exposure Compliance

1.11.1. Limit For Maximum Permissible Exposure (MPE)

(A) Limits for Occupational / Controlled Exposure

Frequency Range (MHz)	Electric Field Strength (E) (V/m)	Magnetic Field Strength (H) (A/m)	Power Density (S) (mW/ cm ²)	Averaging Time E ² , H ² or S (minutes)
0.3-3.0	614	1.63	(100)*	6
3.0-30	1842/f	4.89/f	(900/f)*	6
30-300	61.4	0.163	1.0	6
300-1500			F/300	6
1500-100,000			5	6

(B) Limits for General Population / Uncontrolled Exposure

Frequency Range (MHz)	Electric Field Strength (E) (V/m)	Magnetic Field Strength (H) (A/m)	Power Density (S) (mW/cm ²)	Averaging Time E ² , H ² or S (minutes)
0.3-1.34	614	1.63	(100)*	30
1.34-30	824/f	2.19/f	(180/f)*	30
30-300	27.5	0.073	0.2	30
300-1500			F/1500	30
1500-100,000			1.0	30

F=frequency in MHz

*Plane-wave equivalent power density

1.11.2. MPE Calculations

$$E \text{ (V/m)} = \frac{\sqrt{30 \cdot P \cdot G}}{d} \quad \text{Power Density: Pd (mW/cm}^2\text{)} = \frac{E^2}{3770}$$

E = Electric field (V/m)

P = Peak output power (W)

G = Antenna numeric gain (numeric)

d = Separation distance (m)

Because the EUT is belong to General Population/ Uncontrolled Exposure. So the Limit of Power Density is 10 W/m². We can change the formula to:

$$d = \sqrt{\frac{30 \cdot P \cdot G}{3770}}$$

1.11.3. FCC Radiation Exposure Statement

This equipment complies with FCC radiation exposure limits set forth for an uncontrolled environment. In order to avoid the possibility of exceeding the FCC radio frequency exposure limits, human proximity to the antenna shall not be less than 20cm (8 inches) during normal operation. Proposed RF exposure safety information to include in User's Manual.

2. Test Configuration of Equipment under Test

2.1. Test Mode and Test Software

The following test mode and test software was performed for conduction and radiation test:

- 802.11b (CH LO: 2412MHz) • 802.11b (CH MID: 2437MHz) • 802.11b (CH HI: 2462MHz)
- 802.11g (CH LO: 2412MHz) • 802.11g (CH MID: 2437MHz) • 802.11g (CH HI: 2462MHz)
- An executive programs, "DUTAPIDLL" Application under WIN XP.

2.2. •Description of Test System

Device	Manufacturer	Model No.	Description
PC(Remote side)	IBM	IGV	Power Cable, Unshielding 1.8 m
Monitor (Remote side)	SlimAGE	510A	Power Cable, Adapter Unshielding 1.8 m Data Cable, VGA shielding 1.35 m
Keyboard (Remote side)	IBM	KB-0225	Data Cable, PS2 shielding 1.85 m
Mouse (Remote side)	IBM	MO28VO	Data Cable, USB shielding 1.85 m
Notebook (Remote side)	IBM	R40(2723-BV1)	Power Cable, Adapter Unshielding 1.8 m
Homeplug (Remote side)	N/A	N/A	Power Cable, Unshielding 1.8 m

2.3. Connection Diagram of Test System

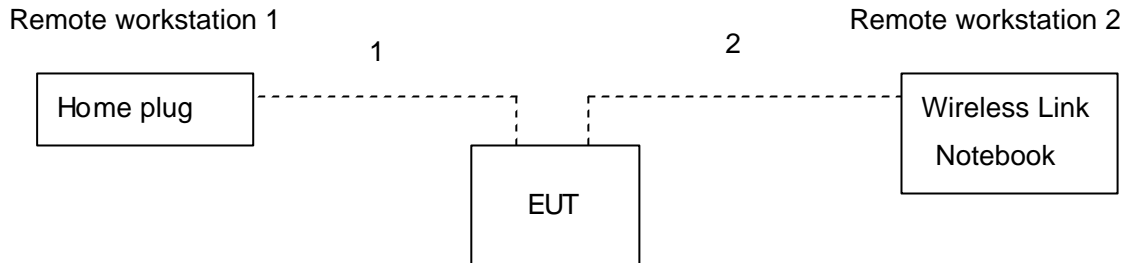

1. The TP cable is connected from remote workstation 1 to the EUT.
2. The TP cable is connected from remote workstation 2 to the EUT

2.4. Feature of Equipment under Test

- 802.11g wireless networking, with the ability to operate in 802.11g-only, or 802.11b+g modes.
- Easy, Web-based setup for installation and management.
- Content Filtering and Site Blocking Security.
- Ethernet connection to a wide area network (WAN) device, such as a cable modem or DSL modem.
- Extensive Protocol Support.
- Login capability.
- Front panel LEDs for easy monitoring of status and activity.
- Flash memory for firmware upgrades.

2.5. History of this test report

ORIGINAL.

3. General Information of Test

Test Site:	Exclusive Certification Corp. 4F-2, No. 28, Lane 78, Xing-Ai Rd. Nei-hu, Taipei City 114 Taiwan R.O.C.
Test Site Location (OATS1-SD):	No.68-1, Shihbachongsi, shihding Township, Taipei County 223, Taiwan, R.O.C.
Test Voltage:	AC 110V/ 60Hz
Test in Compliance with:	ANSI C63.4-1992 FCC Part 15 Subpart C
Frequency Range Investigated:	Conducted: from 150kHz to 30 MHz Radiation: from 30 MHz to 24620MHz
Test Distance:	1.The test distance of radiated emission above 1GHz from antenna to EUT is 3 M. 2.The test distance of radiated emission below 1GHz from antenna to EUT is 10 M.

4. Test Result and Data

4.1. Antenna Requirement

4.1.1. Antenna Construction and Directional Gain

Antenna type: Integral PIFA Antenna

Gain: +1.0 dBi.

4.2. Test Result of Conducted Emission

EUT : W6X-102
 Power : 110V 60Hz
 Test Mode : 802.11b CH LO
 Memo :

Pol/Phase : NEUTRAL
 Temperature : 25 °C
 Humidity : 58 %

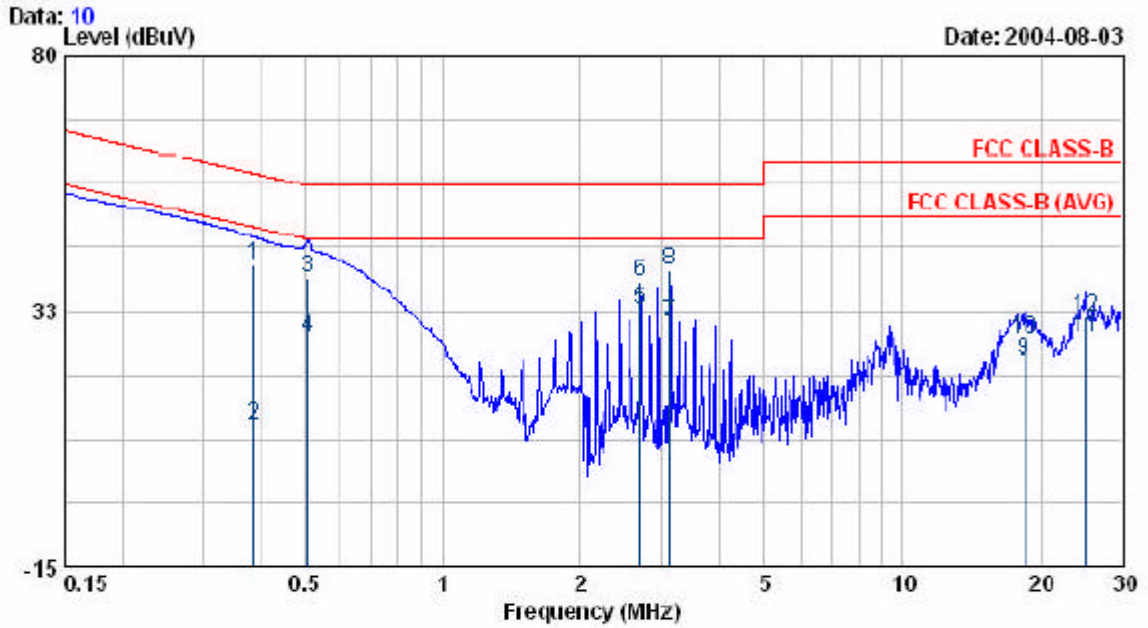

Freq	Read Level	Factor	Level	Limit	Over Limit	Remark
MHz	dBuV	dB	dBuV	dBuV	dBuV	
0.387	40.42	0.46	40.88	58.13	-17.26	QP
0.387	10.92	0.46	11.38	48.13	-36.76	AVERAGE
0.507	38.28	0.47	38.75	56.00	-17.25	QP
0.507	27.04	0.47	27.51	46.00	-18.49	AVERAGE
2.697	32.16	0.56	32.72	46.00	-13.28	AVERAGE
2.697	37.26	0.56	37.82	56.00	-18.18	QP
3.099	29.61	0.56	30.17	46.00	-15.83	AVERAGE
3.099	39.47	0.56	40.03	56.00	-15.97	QP
18.427	22.59	0.84	23.43	50.00	-26.57	AVERAGE
18.427	25.14	0.84	26.98	60.00	-33.02	QP
25.069	26.46	0.99	27.45	50.00	-22.55	AVERAGE
25.069	30.23	0.99	31.22	60.00	-28.78	QP

EUT : WGX-102
 Power : 110V 60Hz
 Test Mode : 802.11b CH LO
 Memo :

Pol/Phase : LINE
 Temperature : 25 °C
 Humidity : 58 %

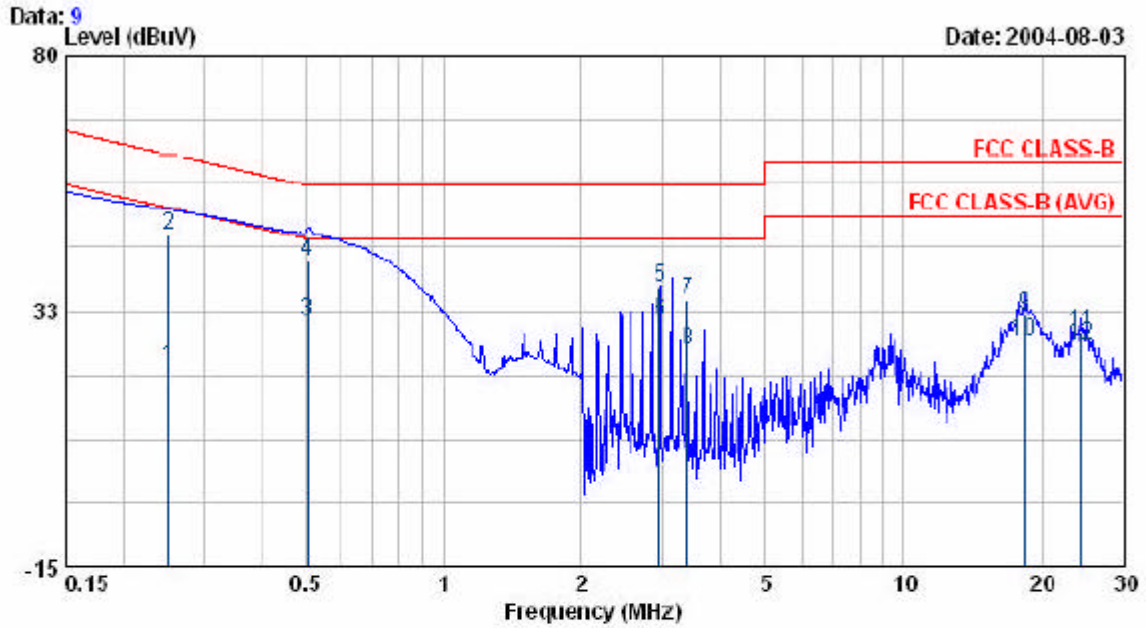

Freq	Read Level	Factor	Level	Limit	Over Limit	Remark
MHz	dBuV	dB	dBuV	dBuV	dBuV	
0.251	21.51	0.43	21.94	51.73	-29.79	AVERAGE
0.251	46.23	0.43	46.66	61.73	-15.07	QP
0.505	30.06	0.47	30.53	46.00	-15.47	AVERAGE
0.505	41.30	0.47	41.77	56.00	-14.23	QP
2.967	36.30	0.56	36.86	56.00	-19.14	QP
2.967	29.87	0.56	30.43	46.00	-15.57	AVERAGE
3.370	33.68	0.57	34.25	56.00	-21.75	QP
3.370	24.38	0.57	24.95	46.00	-21.05	AVERAGE
18.352	30.89	0.84	31.73	60.00	-28.27	QP
18.352	25.89	0.84	26.73	50.00	-23.27	AVERAGE
24.395	27.42	1.24	28.66	60.00	-31.34	QP
24.395	24.68	1.24	25.92	50.00	-24.08	AVERAGE

EUT : W6X-102
 Power : 110V 60Hz
 Test Mode : 802.11b CH MID
 Memo :

Pol/Phase : NEUTRAL
 Temperature : 25 °C
 Humidity : 58 %

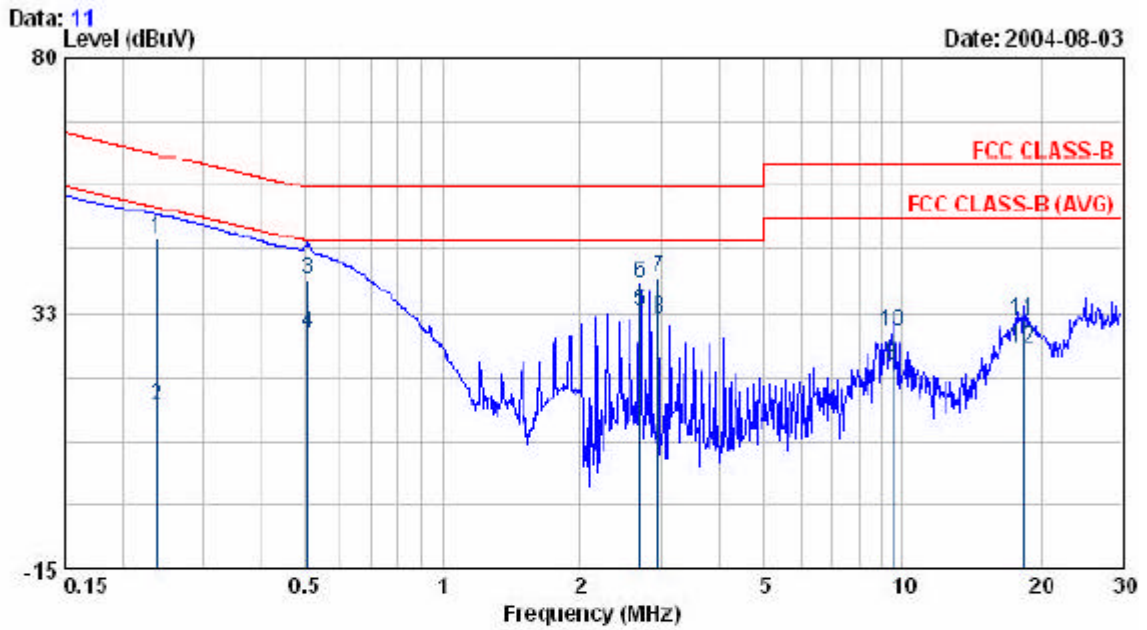

Freq	Read Level	Factor	Level	Limit	Over Limit	Remark
MHz	dBuV	dB	dBuV	dBuV	dBuV	
0.239	45.72	0.43	46.15	62.13	-15.98	QP
0.239	14.87	0.43	15.30	52.13	-36.83	AVERAGE
0.507	38.23	0.47	38.70	56.00	-17.30	QP
0.507	27.86	0.47	28.33	46.00	-17.67	AVERAGE
2.696	32.13	0.56	32.69	46.00	-13.31	AVERAGE
2.696	37.31	0.56	37.87	56.00	-18.13	QP
2.965	38.31	0.56	38.87	56.00	-17.13	QP
2.965	30.85	0.56	31.41	46.00	-14.59	AVERAGE
9.496	22.34	0.72	23.06	50.00	-26.94	AVERAGE
9.496	28.22	0.72	28.94	60.00	-31.06	QP
18.351	30.18	0.84	31.02	60.00	-28.98	QP
18.351	24.89	0.84	25.73	50.00	-24.27	AVERAGE

EUT : WGX-102
 Power : 110V 60Hz
 Test Mode : 802.11b CH MID
 Memo :

Pol/Phase : LINE
 Temperature : 25 °C
 Humidity : 58 %

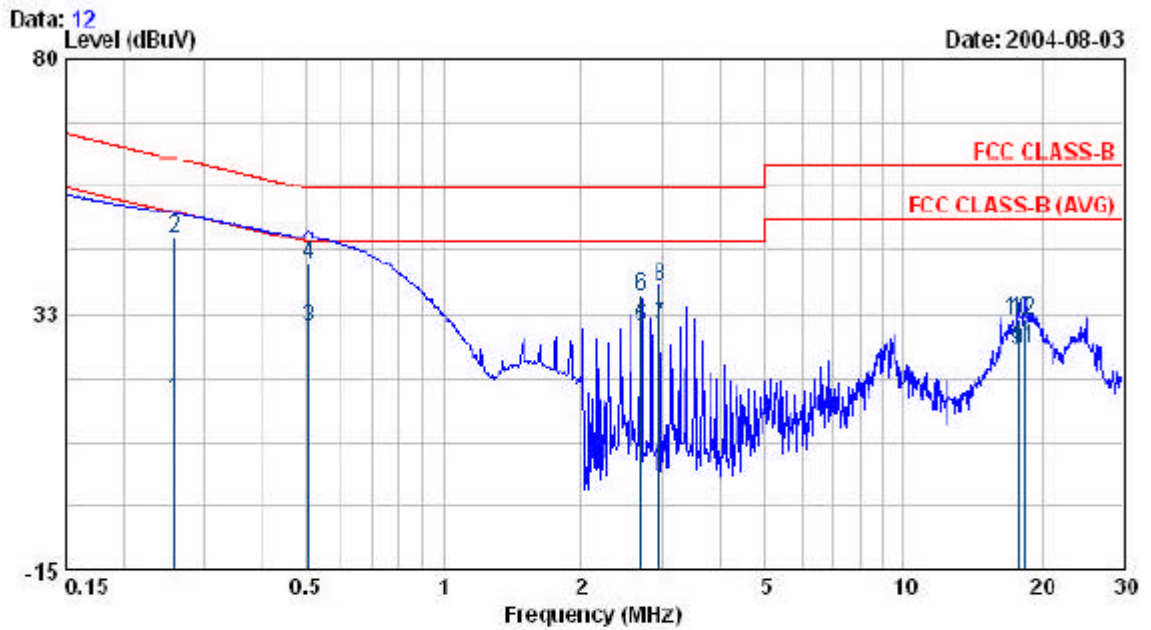

Freq	Read Level	Factor	Level	Limit	Over Limit	Remark
MHz	dBuV	dB	dBuV	dBuV	dBuV	
0.259	16.09	0.43	16.52	51.47	-34.94	AVERAGE
0.259	45.99	0.43	46.42	61.47	-15.04	QP
0.507	29.53	0.47	30.00	46.00	-16.00	AVERAGE
0.507	41.20	0.47	41.67	56.00	-14.33	QP
2.697	29.22	0.56	29.78	46.00	-16.22	AVERAGE
2.697	35.39	0.56	35.95	56.00	-20.05	QP
2.965	29.73	0.56	30.29	46.00	-15.71	AVERAGE
2.965	36.84	0.56	37.40	56.00	-18.60	QP
17.740	25.06	0.82	25.88	50.00	-24.12	AVERAGE
17.740	30.50	0.82	31.32	60.00	-28.68	QP
18.353	25.37	0.84	26.21	50.00	-23.79	AVERAGE
18.353	30.43	0.84	31.27	60.00	-28.73	QP

EUT : W6X-102
 Power : 110V 60Hz
 Test Mode : 802.11b CH HI
 Memo :

Pol/Phase : NEUTRAL
 Temperature : 25 °C
 Humidity : 58 %

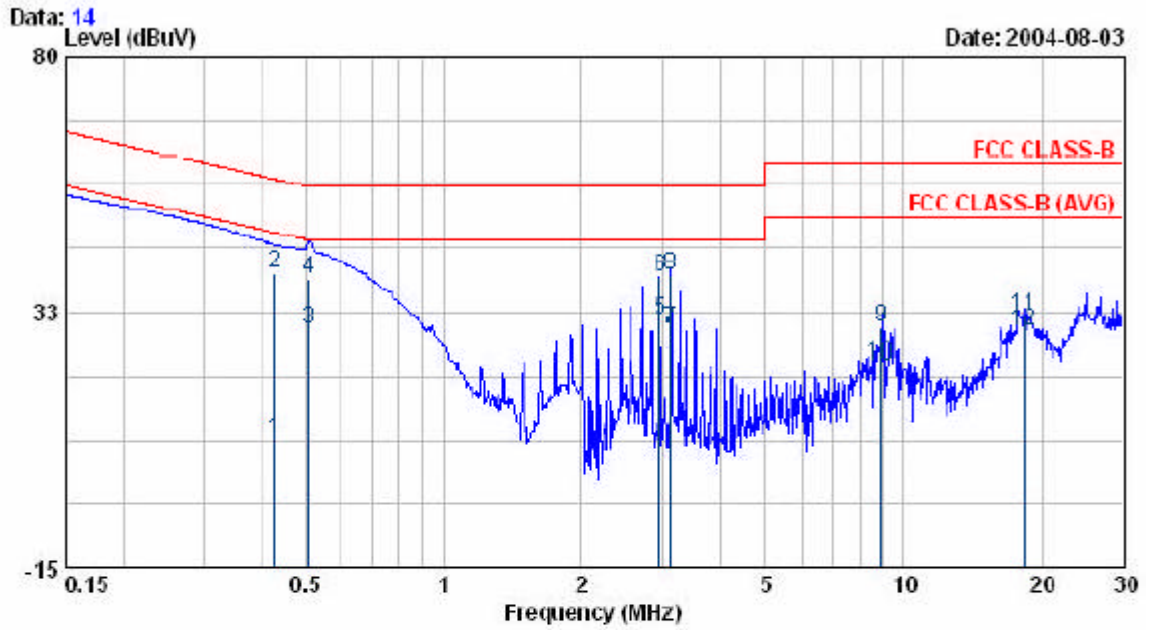

Freq	Read Level	Factor	Level	Limit	Over Limit	Remark
MHz	dBuV	dB	dBuV	dBuV	dBuV	
0.428	8.55	0.46	9.01	47.29	-38.27	AVERAGE
0.428	39.05	0.46	39.51	57.29	-17.77	QP
0.507	28.80	0.47	29.27	46.00	-16.73	AVERAGE
0.507	38.16	0.47	38.63	56.00	-17.37	QP
2.962	30.41	0.56	30.97	46.00	-15.03	AVERAGE
2.962	38.40	0.56	38.96	56.00	-17.04	QP
3.097	28.63	0.56	29.19	46.00	-16.81	AVERAGE
3.097	38.69	0.56	39.25	56.00	-16.75	QP
8.944	28.72	0.70	29.42	60.00	-30.58	QP
8.944	21.96	0.70	22.66	50.00	-27.34	AVERAGE
18.304	30.96	0.84	31.80	60.00	-28.20	QP
18.304	28.05	0.84	28.89	50.00	-21.11	AVERAGE

EUT : W6X-102
 Power : 110V 60Hz
 Test Mode : 802.11b CH HI
 Memo :

Pol/Phase : LINE
 Temperature : 25 °C
 Humidity : 58 %

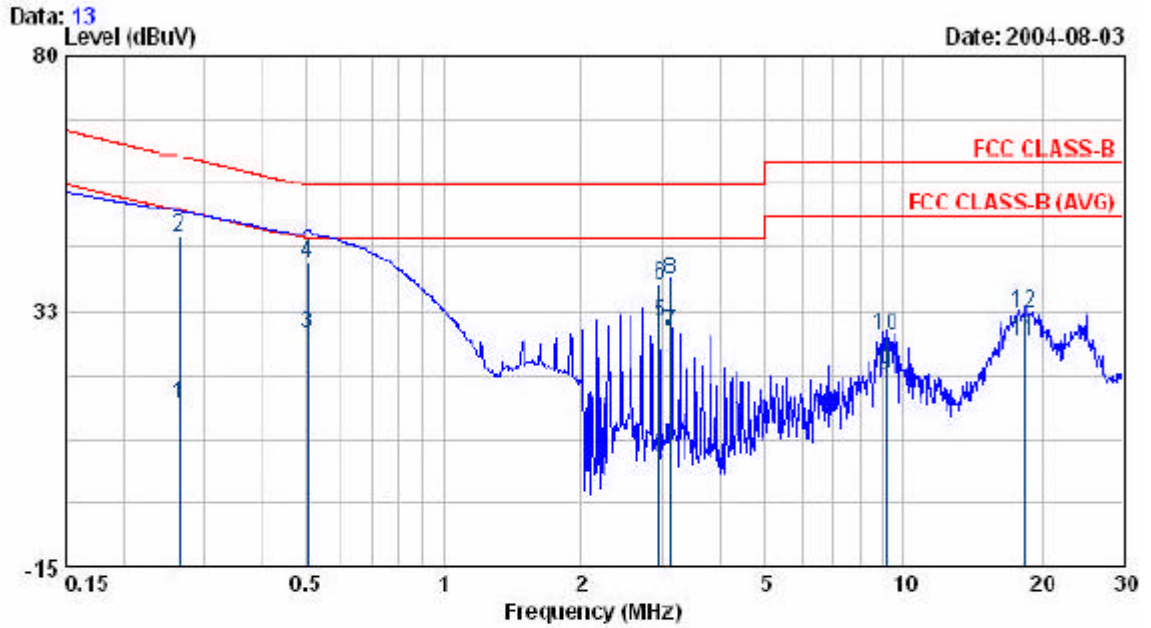

Freq	Read Level	Factor	Level	Limit	Over Limit	Remark
MHz	dBuV	dB	dBuV	dBuV	dBuV	
0.264	14.90	0.43	15.33	51.29	-35.96	AVERAGE
0.264	45.79	0.43	46.22	61.29	-15.07	QP
0.504	27.78	0.47	28.25	46.00	-17.75	AVERAGE
0.504	40.84	0.47	41.31	56.00	-14.69	QP
2.963	29.65	0.56	30.21	46.00	-15.79	AVERAGE
2.963	36.69	0.56	37.25	56.00	-18.75	QP
3.099	28.08	0.56	28.64	46.00	-17.36	AVERAGE
3.099	37.78	0.56	38.34	56.00	-17.66	QP
9.128	20.35	0.62	20.97	50.00	-29.03	AVERAGE
9.128	27.14	0.62	27.76	60.00	-32.24	QP
18.350	25.90	0.84	26.74	50.00	-23.26	AVERAGE
18.350	31.29	0.84	32.13	60.00	-27.87	QP

EUT : W0X-102
 Power : 110V 60Hz
 Test Mode : 802.11g CH LO
 Memo :

Pol/Phase : NEUTRAL
 Temperature : 25 °C
 Humidity : 58 %

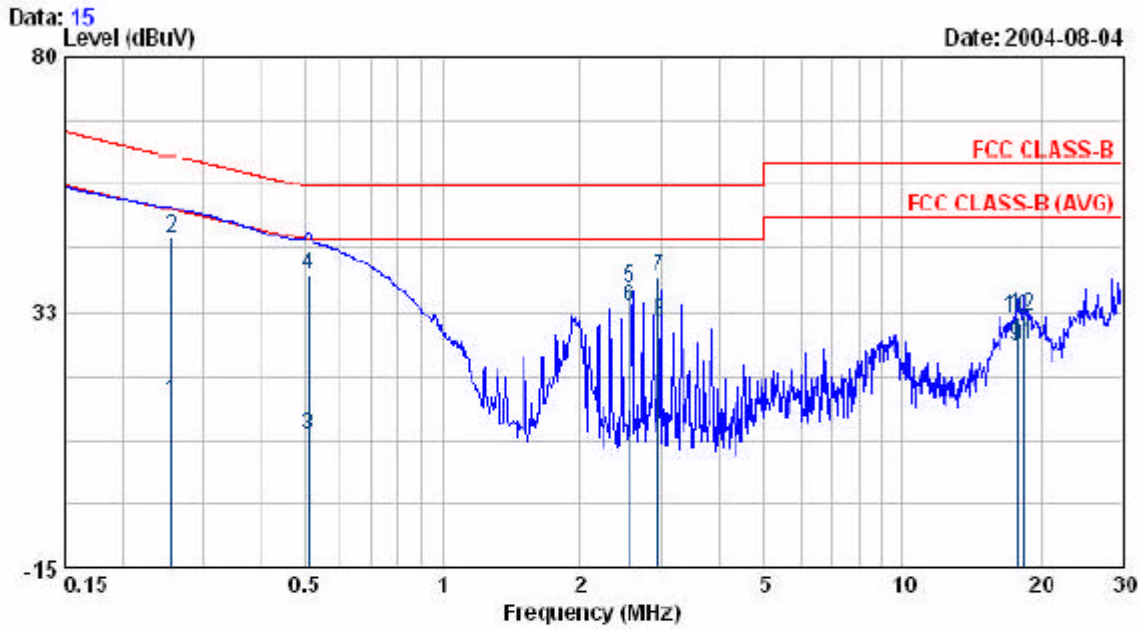

Freq	Read Level	Factor	Level	Limit	Over Limit	Remark
MHz	dBuV	dB	dBuV	dBuV	dBuV	
0.256	15.39	0.43	15.82	51.55	-35.73	AVERAGE
0.256	45.97	0.43	46.40	61.55	-15.15	QP
0.508	9.15	0.47	9.62	46.00	-36.38	AVERAGE
0.508	38.88	0.47	39.35	56.00	-16.65	QP
2.564	36.26	0.55	36.81	56.00	-19.19	QP
2.564	32.75	0.55	33.30	46.00	-12.70	AVERAGE
2.967	38.39	0.56	38.95	56.00	-17.05	QP
2.967	29.90	0.56	30.46	46.00	-15.54	AVERAGE
17.741	25.09	0.82	25.91	50.00	-24.09	AVERAGE
17.741	30.58	0.82	31.40	60.00	-28.60	QP
18.351	25.49	0.84	26.33	50.00	-23.67	AVERAGE
18.351	30.63	0.84	31.47	60.00	-28.53	QP

EUT : W6X-102
 Power : 110V 60Hz
 Test Mode : 802.11g CH L0
 Memo :

Pol/Phase : LINE
 Temperature : 25 °C
 Humidity : 58 %

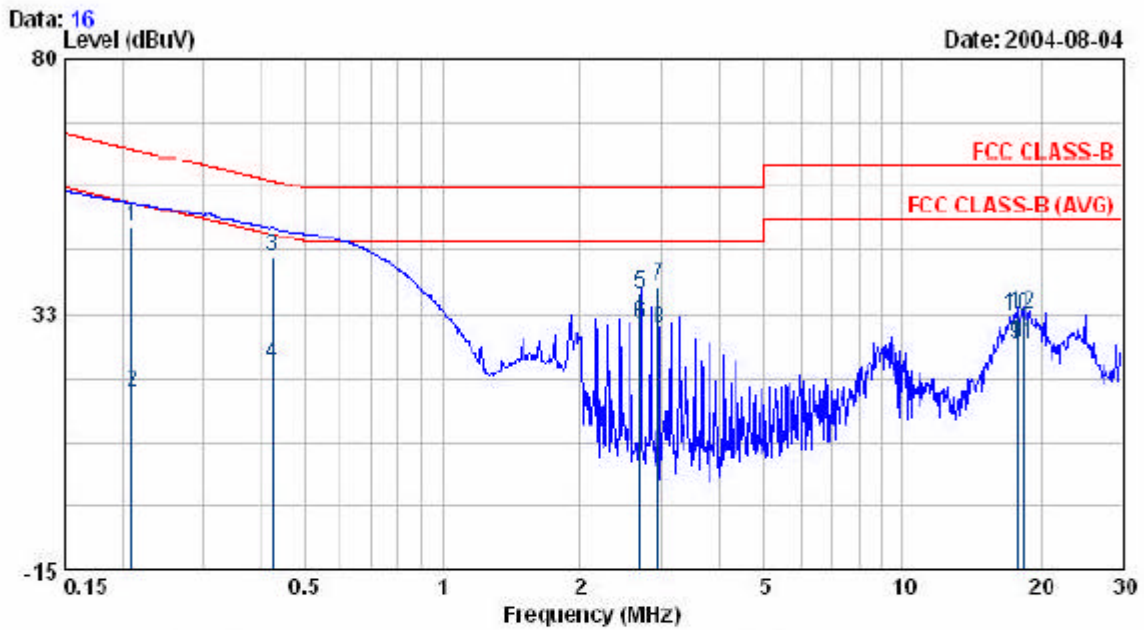

Freq	Read Level	Factor	Level	Limit	Over Limit	Remark
MHz	dBuV	dB	dBuV	dBuV	dBuV	
0.211	48.16	0.42	48.58	63.18	-14.60	QP
0.211	17.50	0.42	17.92	53.18	-35.26	AVERAGE
0.426	42.50	0.46	42.96	57.32	-14.36	QP
0.426	22.36	0.46	22.82	47.32	-24.50	AVERAGE
2.701	35.44	0.56	36.00	56.00	-20.00	QP
2.701	30.03	0.56	30.59	46.00	-15.41	AVERAGE
2.967	36.93	0.56	37.51	56.00	-18.49	QP
2.967	29.06	0.56	29.62	46.00	-16.38	AVERAGE
17.740	25.84	0.82	26.66	50.00	-23.34	AVERAGE
17.740	31.22	0.82	32.04	60.00	-27.96	QP
18.350	26.06	0.84	26.90	50.00	-23.10	AVERAGE
18.350	31.36	0.84	32.20	60.00	-27.80	QP

EUT : WGX-102
 Power : 110V 60Hz
 Test Mode : 802.11g CH MID
 Memo :

Pol/Phase : NEUTRAL
 Temperature : 25 °C
 Humidity : 58 %

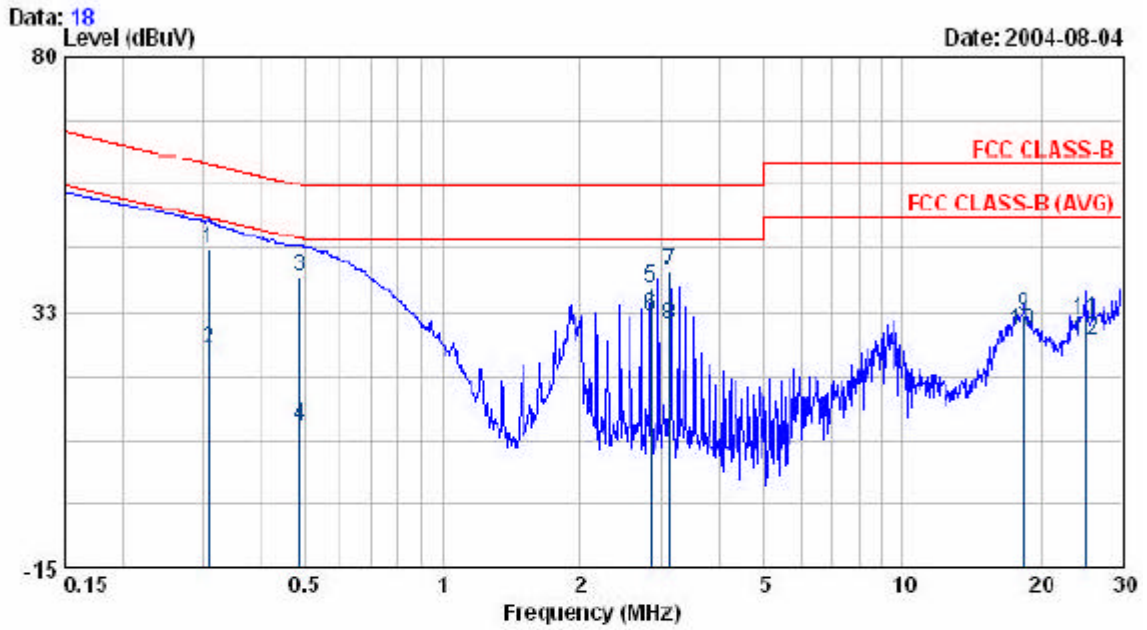

Freq	Read Level	Factor	Level	Limit	Over Limit	Remark
MHz	dBuV	dB	dBuV	dBuV	dBuV	
0.310	43.57	0.44	44.01	59.97	-15.96	QP
0.310	24.96	0.44	25.40	49.97	-24.57	AVERAGE
0.489	38.62	0.47	39.09	56.19	-17.10	QP
0.489	11.06	0.47	11.53	46.19	-34.66	AVERAGE
2.838	36.17	0.56	36.73	56.00	-19.27	QP
2.838	31.12	0.56	31.68	46.00	-14.32	AVERAGE
3.109	39.28	0.56	39.84	56.00	-16.16	QP
3.109	29.42	0.56	29.98	46.00	-16.02	AVERAGE
18.304	30.91	0.84	31.75	60.00	-28.25	QP
18.304	28.11	0.84	28.95	50.00	-21.05	AVERAGE
25.067	29.97	0.99	30.96	60.00	-29.04	QP
25.067	26.11	0.99	27.10	50.00	-22.90	AVERAGE

EUT : W6X-102
 Power : 110V 60Hz
 Test Mode : 802.11g CH MID
 Memo :
 Pol/Phase : LINE
 Temperature : 25 °C
 Humidity : 58 %

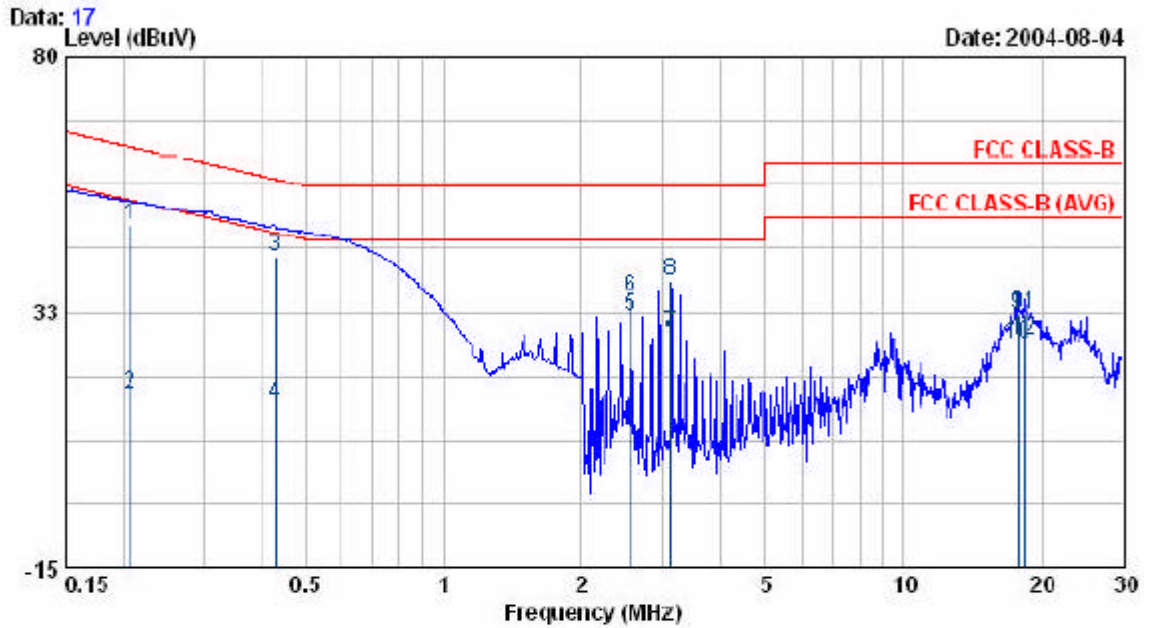

Freq	Read Level	Factor	Level	Limit	Over Limit	Remark
MHz	dBuV	dB	dBuV	dBuV	dBuV	
0.206	48.11	0.42	48.53	63.36	-14.83	QP
0.206	16.89	0.42	17.31	53.36	-36.05	AVERAGE
0.429	42.23	0.46	42.69	57.27	-14.58	QP
0.429	15.01	0.46	15.47	47.27	-31.80	AVERAGE
2.562	30.94	0.55	31.49	46.00	-14.51	AVERAGE
2.562	34.43	0.55	34.98	56.00	-21.02	QP
3.102	28.05	0.56	28.61	46.00	-17.39	AVERAGE
3.102	37.55	0.56	38.11	56.00	-17.89	QP
17.740	31.07	0.82	31.89	60.00	-28.11	QP
17.740	25.62	0.82	26.44	50.00	-23.56	AVERAGE
18.352	31.19	0.84	32.03	60.00	-27.97	QP
18.352	26.17	0.84	27.01	50.00	-22.99	AVERAGE

EUT : W6X-102
 Power : 110V 60Hz
 Test Mode : 802.11g CH HI
 Memo :

Pol/Phase : NEUTRAL
 Temperature : 25 °C
 Humidity : 58 %

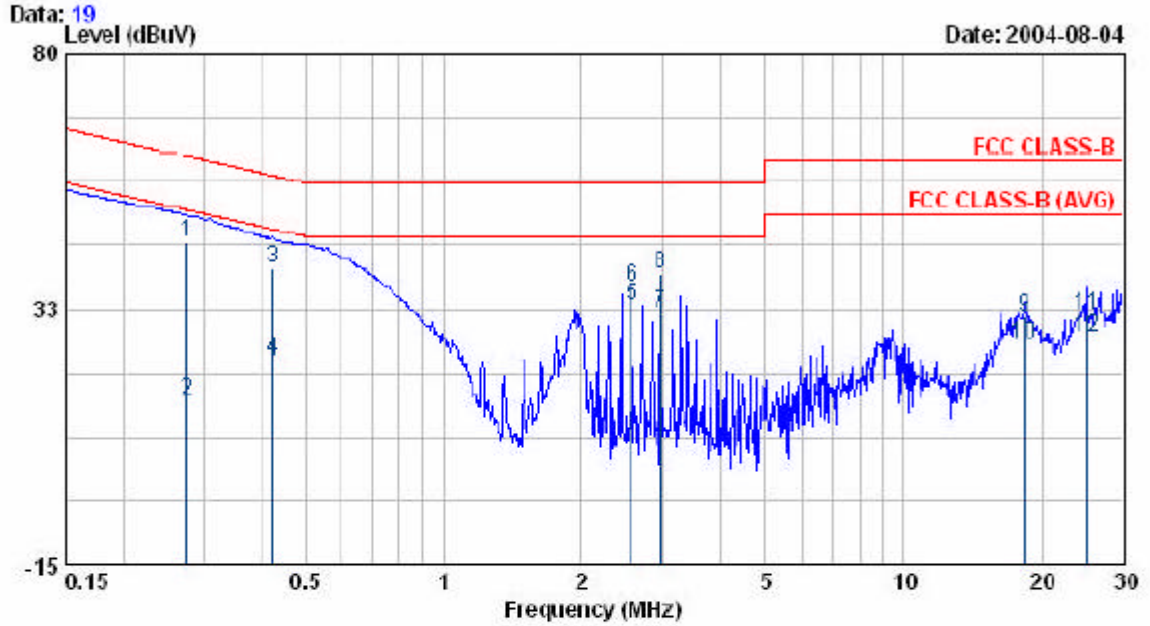

Freq	Read Level	Factor	Level	Limit	Over Limit	Remark
MHz	dBuV	dB	dBuV	dBuV	dBuV	
0.276	44.57	0.44	45.01	60.94	-15.93	QP
0.276	15.30	0.44	15.74	50.94	-35.20	AVERAGE
0.424	39.62	0.46	40.08	57.38	-17.29	QP
0.424	22.46	0.46	22.92	47.38	-24.45	AVERAGE
2.573	32.63	0.55	33.18	46.00	-12.82	AVERAGE
2.573	36.11	0.55	36.66	56.00	-19.34	QP
2.978	30.94	0.56	31.50	46.00	-14.50	AVERAGE
2.978	38.29	0.56	38.85	56.00	-17.15	QP
18.351	30.16	0.84	31.00	60.00	-29.00	QP
18.351	24.91	0.84	25.75	50.00	-24.25	AVERAGE
25.068	30.14	0.99	31.13	60.00	-28.87	QP
25.068	26.09	0.99	27.08	50.00	-22.92	AVERAGE

EUT : W6X-102
 Power : 110V 60Hz
 Test Mode : 802.11g CH HI
 Memo :

Pol/Phase : LINE
 Temperature : 25 °C
 Humidity : 58 %

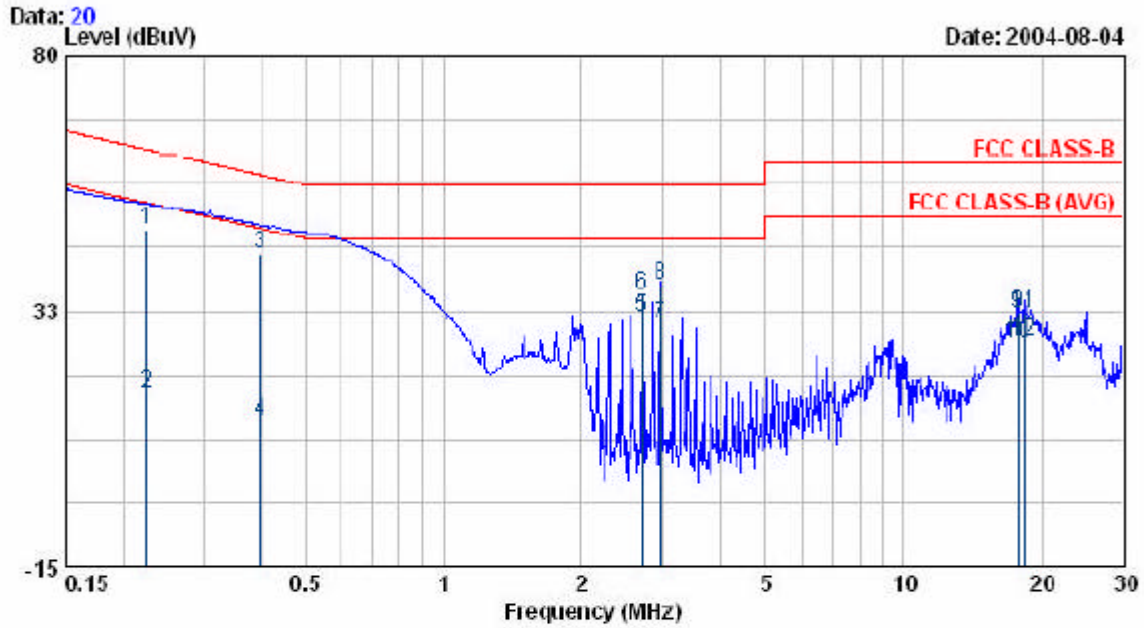

Freq	Read	Factor	Level	Limit	Over	Remark
MHz	dBuV	dB	dBuV	dBuV	dBuV	
0.224	47.35	0.42	47.77	62.65	-14.88	QP
0.224	16.87	0.42	17.29	52.65	-35.36	AVERAGE
0.397	42.70	0.46	43.16	57.92	-14.76	QP
0.397	11.82	0.46	12.28	47.92	-35.64	AVERAGE
2.712	30.63	0.56	31.19	46.00	-14.81	AVERAGE
2.712	35.00	0.56	35.56	56.00	-20.44	QP
2.981	29.18	0.56	29.74	46.00	-16.26	AVERAGE
2.981	36.62	0.56	37.18	56.00	-18.82	QP
17.740	31.12	0.82	31.94	60.00	-28.06	QP
17.740	25.59	0.82	26.41	50.00	-23.59	AVERAGE
18.351	31.17	0.84	32.01	60.00	-27.99	QP
18.351	25.98	0.84	26.82	50.00	-23.18	AVERAGE

Test by: Carol

4.2.1. Photographs of Conducted Emission Test

FRONT VIEW



REAR VIEW

