



## TEST REPORT

**Product Name** : Double 108 Mbps Wireless USB 2.0 Adapter WG111U  
**Model Number** : WG111U  
**Brand Name** : NETGEAR  
**FCC ID** : PY3WG111U

**Applicant** : Netgear Incorporated  
**Address** : 4500 Great America Parkway Santa Clara,  
CA95054 U.S.A

**Received Date** : November 15, 2004  
**Tested Date** : November 15 ~ December 14, 2004

Notes :

1. This report will be invalid if duplicated or photocopied in part.
2. This report refers only to the specimen(s) submitted to testing, and be invalid as seperately used.
3. This report is invalid without examination stamp and signature of this institute.
4. The tested specimen(s) will be preserved for thirty days from the data issued.
5. The report must not be used to claim product certification, approval, or endorsement by NVLAP, NIST, or any agency of the federal government.





**Ecom Sertech Corp.**

Rm. 258, Bldg. 17, NO.195, Sec.4 Chung Hsing Rd., ChuTugn Chen, Hsinchu, Taiwan 310, R.O.C  
TEL: 886-3-5918012 FAX: 886-3-5825720

FCC ID : PY3WG111U

Report No. : ER04-11-043FRFa

Page 2 of 84

## Test Report Certification

**Product Name** : Double 108 Mbps Wireless USB 2.0 Adapter WG111U  
**Model Number** : WG111U  
**Brand Name** : NETGEAR  
**FCC ID** : PY3WG111U  
**Applicant** : Netgear Incorporated

### Measurement Standard :

FCC 47 C.F.R. Part 15, Subpart B and Subpart E (2004)  
 ANSI C63.4 (2003)

**Tested By** : Alan Fan , Date: December 16, 2004  
 (Alan Fan)

**Approved By** : Chieh-De Tsai , Date: December 16, 2004  
 (Chieh-De Tsai, Manager)



WE HEREBY CERTIFY THAT: The measurements shown in the attachment were made in accordance with the procedures indicated, and the energy emitted by the equipment was found to be within the limits applicable. We assume full responsibility for the accuracy and completeness of these measurements and vouch for the qualifications of all persons taking them.



**TABLE OF CONTENTS**

| TITLE   | PAGE NO.  |
|---|-----------|
| <b>1. GENERAL INFORMATION .....</b>                                   | <b>5</b>  |
| 1.1 General Statement.....  | 5         |
| 1.2 General Description of EUT & Power.....                           | 5         |
| 1.3 Tested Channel .....  | 6         |
| 1.4 Description of Peripherals.....                                   | 6         |
| 1.5 EUT & Peripherals Setup Diagram.....                              | 7         |
| 1.6 EUT Operating Procedure.....                                      | 8         |
| 1.7 Description of Laboratory.....                                    | 8         |
| 1.8 SUMMARY of RESULTS .....  | 9         |
| <b>2. CONDUCTED POWERLINE TEST .....</b>                              | <b>10</b> |
| 2.1 Test Equipments .....   | 10        |
| 2.2 Test Setup .....  | 10        |
| 2.3 Conducted Power Line Emission Limit.....                          | 11        |
| 2.4 Test Procedure .....  | 11        |
| 2.5 Uncertainty of Conducted Emission .....                           | 11        |
| 2.6 Conducted RF Voltage Measurement.....                             | 12-13     |
| 2.7 Photos of Conduction Test.....                                    | 14        |
| <b>3. RADIATED EMISSION TEST .....</b>                                | <b>15</b> |
| 3.1 Test Equipments .....   | 15        |
| 3.2 Test Setup .....  | 16        |
| 3.3 Radiation Limit.....  | 17        |
| 3.4 Test Procedures.....  | 18        |
| 3.5 Uncertainty of Radiated Emission .....                            | 18        |
| 3.6 Radiated RF Noise Measurement .....                               | 19        |
| 3.6.1 Spurious Emission Below 1GHz.....                               | 19        |
| 3.6.2 Spurious Emission Outside of the 5.15 ~ 5.35GHz Band (TX).....  | 20-33     |
| 3.6.3 Radiated Bandedge Emission of 5.15 ~ 5.35GHz Band .....         | 34        |
| 3.6.4 Photo of Bandedge Measurement .....                             | 35-38     |
| 3.6.5 Spurious Emission Outside of the 5.15 ~ 5.35GHz Band (RX) ..... | 39-52     |
| 3.7 Photos of Open Site .....   | 53-55     |
| <b>4. EMISSION BANDWIDTH MEASUREMENT .....</b>                        | <b>56</b> |
| 4.1 Test Equipments .....   | 56        |
| 4.2 Test Setup .....  | 56        |
| 4.3 Test Procedure .....  | 56        |
| 4.4 Uncertainty of Conducted Emission .....                           | 56        |
| 4.5 Test Results.....   | 57        |
| 4.6 Photo of 26db Bandwidth Measurement.....                          | 58-61     |



---

**TABLE OF CONTENTS**

| TITLE  | PAGE NO.  |
|--|-----------|
| <b>5. PEAK CONDUCTED TRANSMIT POWER.....</b>                 | <b>62</b> |
| 5.1 Test Equipments .....                                    | 62        |
| 5.2 Test Setup .....   | 62        |
| 5.3 Limits of Maximum Peak Output Power .....                | 63        |
| 5.4 Test Procedure .....                                     | 63        |
| 5.5 Uncertainty of Conducted Emission .....                  | 63        |
| 5.6 Test Results.....  | 64        |
| 5.7 Photo of Peak Conducted Transmit Power Measurement ..... | 65-68     |
| <b>6. PEAK POWER DENSITY MEASUREMENT.....</b>                | <b>69</b> |
| 6.1 Test Equipments .....                                    | 69        |
| 6.2 Test Setup .....   | 69        |
| 6.3 Limits of Power Spectral Density Measurement .....       | 69        |
| 6.4 Test Procedure .....                                     | 70        |
| 6.5 Uncertainty of Conducted Emission .....                  | 70        |
| 6.6 Test Results.....  | 70        |
| 6.7 Photo of Peak Power Density Measurement.....             | 71-74     |
| <b>7. PEAK POWER EXCURSION MEASUREMENT .....</b>             | <b>75</b> |
| 7.1 Test Equipments .....                                    | 75        |
| 7.2 Test Setup .....   | 75        |
| 7.3 Limits of Band Edge Emissions Measurement .....          | 75        |
| 7.4 Test Procedure .....                                     | 75        |
| 7.5 Uncertainty of Conducted Emission .....                  | 76        |
| 7.6 Test Results.....  | 76        |
| 7.7 Photo of Peak Power Excursion Measurement.....           | 77-80     |
| <b>8. REQUIREMENT STABILITY .....</b>                        | <b>81</b> |
| 8.1 Standard Applicable.....                                 | 81        |
| 8.2 Test Setup .....   | 81        |
| 8.3 Limits of Out of Band Emissions Measurement .....        | 81        |
| 8.4 Test Procedure .....                                     | 82        |
| 8.5 Uncertainty of Conducted Emission .....                  | 82        |
| 8.6 Test Results.....  | 83        |
| <b>9. ANTENNA REQUIREMENT .....</b>                          | <b>84</b> |
| 9.1 Standard Applicable.....                                 | 84        |
| 9.2 Antenna Connected Construction .....                     | 84        |



# 1. GENERAL INFORMATION

## 1.1 General Statement

MEASUREMENT DEVIATION : Comply with standard in full

TRACEABILITY : This test result is traceable to National or International std.

## 1.2 General Description of EUT & Power

|                            |   |
|----------------------------|---|
| <b>Product Name</b>        | Double 108 Mbps Wireless USB 2.0 Adapter WG111U   |
| <b>Model Number</b>        | WG111U  |
| <b>Operating Frequency</b> | ◆IEEE 802.11a<br>USA(FCC) : 5.15GHz ~ 5.25GHz ; 5.25GHz ~ 5.35GHz;<br>5.725GHz ~ 5.825GHz ; 5.825GHz ~ 5.850GHz<br>◆IEEE 802.11b/g ISM Band<br>USA(FCC) : 2.412GHz ~ 2.462GHz (CH1 ~ CH11)  |
| <b>Channel Number</b>      | 11 channel for 802.11b/g<br>8 channel for 802.11a   |
| <b>Channel Spacing</b>     | 20MHz   |
| <b>Modulation</b>          | ◆IEEE 802.11a (OFDM) : 48/54 Mbps (QAM-64), 24/36 Mbps (QAM-64), 12/18 Mbps (QPSK), 6/9 Mbps (BPSK)<br>◆IEEE 802.11g (OFDM / DSSS) : 48/54 Mbps (QAM-64), 24/36 Mbps (QAM-16), 12/18 Mbps (QPSK) , 6/9 Mbps (BPSK) , 5.5/11 Mbps (CCK) , 2 Mbps (DQPSK) , 1 Mbps (DBPSK)<br>◆IEEE 802.11b (DSSS) : 5.5/11 Mbps (CCK) , 2 Mbps (DQPSK), 1 Mbps (DBPSK) |
| <b>Advanced Mode</b>       | Super A/G mode  |
| <b>Frequency Selection</b> | BY SOFTWARE   |
| <b>Antenna Type</b>        | Patch Antenna<br>Antenna Gain : 3.73dBi at 5GHz, -0.09dBi at 2.4GHz   |
| <b>Power Source</b>        | 5VDC (From USB interface of Notebook)   |



### 1.3 Tested Channel

The following channel were evaluated in this test report.

5.15~5.35GHz

For normal 802.11a mode

| Channel | Carrier center frequency fc (MHz) |
|---------|-----------------------------------|
| 1       | 5180                              |
| 2       | 5200                              |
| 3       | 5220                              |
| 4       | 5240                              |
| 5       | 5260                              |
| 6       | 5280                              |
| 7       | 5300                              |
| 8       | 5320                              |

For Super A mode

| Channel | Carrier center frequency fc (MHz) |
|---------|-----------------------------------|
| Low     | 5210                              |
| -----   | 5230                              |
| Middle  | 5250                              |
| -----   | 5270                              |
| High    | 5290                              |

### 1.4 Description of Peripherals

#### (1) Notebook PC

MANUFACTURER : COMPAQ CORP.  
MODEL NUMBER : N800V  
SERIAL NUMBER : 5Y33KSQZM0W4 1YR  
FCC : DOC  
INPUT POWER : 18.5VDC,65W,3.5A  
POWER CORD : Unshielded, Detachable, 1.8m

#### Adapter

MANUFACTURER : COMPAQ CORP.  
MODEL NUMBER : PPP009L  
SERIAL NUMBER : 4809673805  
INPUT POWER : 100-240VAC 50/60Hz,1.6A  
OUTPUT POWER : 18.5VDC, 65W, 3.5A

**(2) Printer**

MANUFACTURER : HP CORP.  
 MODEL NUMBER : C6431D  
 SERIAL NUMBER : CN19T6S011  
 FCC ID : DOC  
 POWER SOURCE : 100-240VAC,50/60Hz,0.7A  
 SIGNAL CABLE : Shielded , Undetachable , 1.8m

**(3) Notebook PC**

MANUFACTURER : COMPAQ CORP.  
 MODEL NUMBER : N800V  
 SERIAL NUMBER : 5Y31KSQZD1TJ 1YR  
 FCC : DOC  
 INPUT POWER : 18.5VDC,65W,3.5A  
 POWER CORD : Unshielded, Detachable, 1.8m

**Adapter**

MANUFACTURER : COMPAQ CORP.  
 MODEL NUMBER : PPP009L  
 SERIAL NUMBER : 4809672405  
 INPUT POWER : 100-240VAC 50/60Hz,1.6A  
 OUTPUT POWER : 18.5VDC, 65W, 3.5A

**1.5 EUT & Peripherals Setup Diagram**

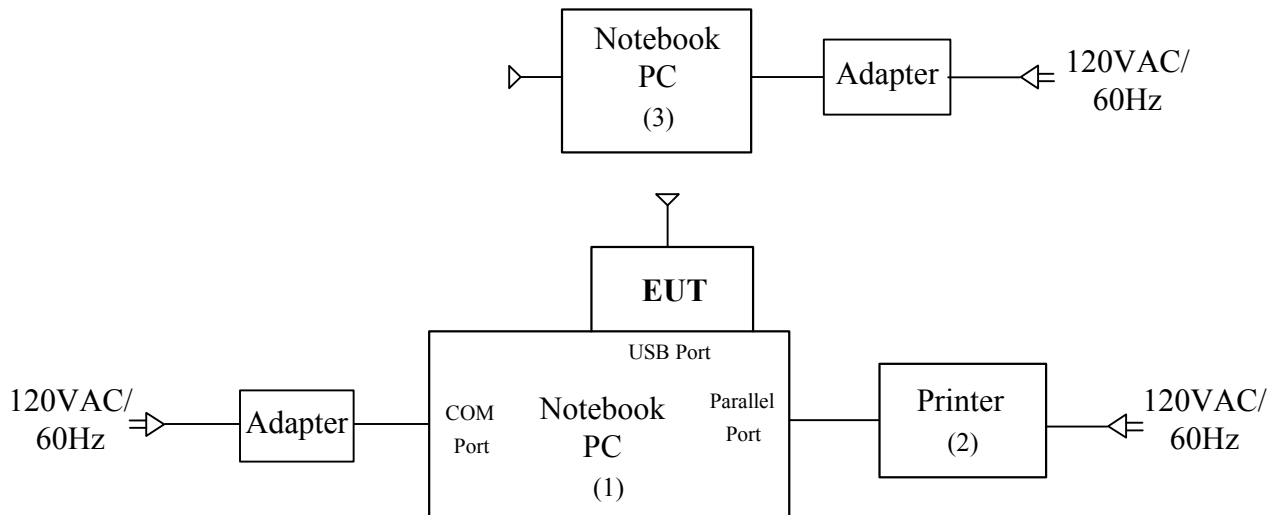

The indicated numbers (1)(2).....please refer to item 1.3



## 1.6 EUT Operating Procedure

1. Set up all computers like the setup diagram.
2. The “**Atheros Radio Test <ART> Revision 4.8 BUILD #16**” software was used for testing.
  - (1) **TX Mode :**
    - ⇒ **Tx Data Rate:54Mbps** (802.11a Mode)
    - ⇒ **Toggle output mode = TX100**
    - ⇒ **Target Power:** 802.11a Mode Channel 1 (5180MHz) = **11.5**  
 802.11a Mode Channel 4 (5240MHz) = **12.5**  
 802.11a Mode Channel 5 (5260MHz) = **12.5**  
 802.11a Mode Channel 8 (5320MHz) = **13.0**
    - ⇒ **“ b “ => Toggle turbo mode**
    - ⇒ **Target Power:** SuperA Turbo Mode Channel Low (5210MHz) = **11.0**  
 SuperA Turbo Mode Channel Middle (5250MHz) = **10.5**  
 SuperA Turbo Mode Channel High (5290MHz) = **11.5**
  - (2) **RX Mode :**
    - ⇒ **Continuous RF <R>eceive mode**
3. Notebook PC (1) ping 192.168.1.10 -t -l 5000 to EUT
4. Notebook PC (4) ping 192.168.1.20 -t -l 5000 to Notebook PC(1)
5. All of the function are under run.
6. Start test.

## 1.7 Description of Laboratory

### SITE DESCRIPTION

|                               |  |
|-------------------------------|--|
| FCC Certificate NO.           | : 90585  |
| BSMI Certificate NO.          | : SL2-IN-E-0002  |
| NVLAP Lab Code                | : 200118-0   |
| CNLA Certificate NO.          | : CNLA-ZL97018E  |
| VCCI Certificate NO.          | : R-1189, C-1250   |
| TÜV Rheinland Certificate NO. | : 10008375   |
| NAME OF SITE                  | : Ecom Sertech Corp. Hsin-Chu Lab.<br>(Spin-off from ITRI / ERSO on Apr. 01, 2003)                 |
| SITE LOCATION                 | : Rm.258, Bldg.17, NO.195 , Sec. 4, Chung Hsing Rd.,<br>Chu-Tung Chen. Hsin-Chu, Taiwan 310 R.O.C. |





### 1.8 SUMMARY of RESULTS

The items of compliance are listed below. The complete data can be found in the Tests data Sheets submitted with this report.

| General requirements for all bands |  |          |   |
|------------------------------------|--|----------|---|
| Standard Section                   | Test Item  | Result   | Comments  |
| 15.407(a)(6)                       | Peak Excursion Ratio   | Complied | < 13dB  |
| 15.407(c)                          | Automatic Discontinuation of Operation in the absence of information to transmit | Complied | Operation is discontinued in the absence of information to transmit, refer to the "Theory of Operations" for a detailed explanation |
| 15.407(g)                          | Frequency Stability  | Complied | Frequency stability is +/- 20ppm  |
| 15.207<br>15.407(b)(6)             | Conducted AC power Line  | Complied | See test results  |

| Operation in the 5.15-5.25GHz Band |                               |          |                        |
|------------------------------------|-------------------------------|----------|------------------------|
| Standard Section                   | Test Item                     | Result   | Comments               |
| 15.407 (e)                         | Indoor operation only         | Complied | Refer to user's manual |
| 15.407 (a) (1)                     | 26dB Bandwidth                | N/A      | See test results       |
| 15.407 (a) (1)                     | Output Power                  | Complied | See test results       |
| 15.407 (a) (1)                     | Power Spectral Density        | Complied | See test results       |
| 15.407 (b) (6)<br>15.209           | Spurious Emissions below 1GHz | Complied | See test results       |
| 15.407 (b) (1)                     | Spurious Emissions above 1GHz | Complied | See test results       |

| Operation in the 5.25-5.35GHz Band |                                    |          |   |
|------------------------------------|------------------------------------|----------|---|
| Standard Section                   | Test Item                          | Result   | Comments  |
| 15.407 (d)                         | Maximum Antenna Gain/ Antenna Type | Complied | Antenna Gain = <u> 3.73dBi at 5GHz </u><br>The antenna is <u> Patch type </u> |
| 15.407(a) (2)                      | Bandwidth                          | N/A      | See test results  |
| 15.407(a) (2)                      | Output Power                       | Complied | See test results  |
| 15.407(a) (2)                      | Power Spectral Density             | Complied | See test results  |
| 15.407(b) (6)<br>15.209            | Spurious Emissions below 1GHz      | Complied | See test results  |
| 15.407(b) (2)                      | Spurious Emissions above 1GHz      | Complied | See test results  |



## 2. CONDUCTED POWERLINE TEST

### 2.1 Test Equipments

The following test equipments are used during the conducted powerline tests :

| Manufacturer or Type           | Model No. | Serial No.             | Date of Calibration  | Calibration Period | Remark  |
|--------------------------------|-----------|------------------------|--|--------------------|---------|
| HP SPECTRUM ANALYZER & DISPLAY | 8594E     | 3801A05627             | April 26, 2004   | 1 Year             | PRETEST |
| SOLAR ISOLATION TRANSFORMER    | 7032-1    | N/A                    | N/A  | N/A                | FINAL   |
| EMCO L.I.S.N.                  | 3850/2    | 9311-1025<br>9401-1028 | January 08, 2004<br>For Characteristic impedance<br>May 18, 2004<br>For Insertion loss | 1 Year             | FINAL   |
| R & S TEST RECEIVER            | ESHS 30   | 838550/003             | February 11, 2004  | 1 Year             | FINAL   |
| KEENE SHIELDED ROOM            | 5983      | No.1                   | N/A  | N/A                | FINAL   |
| R & S PULSE LIMIT              | EHS3Z2    | 357.8810.52            | July 10, 2004  | 1 Year             | FINAL   |
| N TYPE COAXIAL CABLE           | -----     | -----                  | July 10, 2004  | 1 Year             | FINAL   |
| 50Ω TERMINATOR                 | -----     | -----                  | July 10, 2004  | 1 Year             | FINAL   |

### 2.2 Test Setup

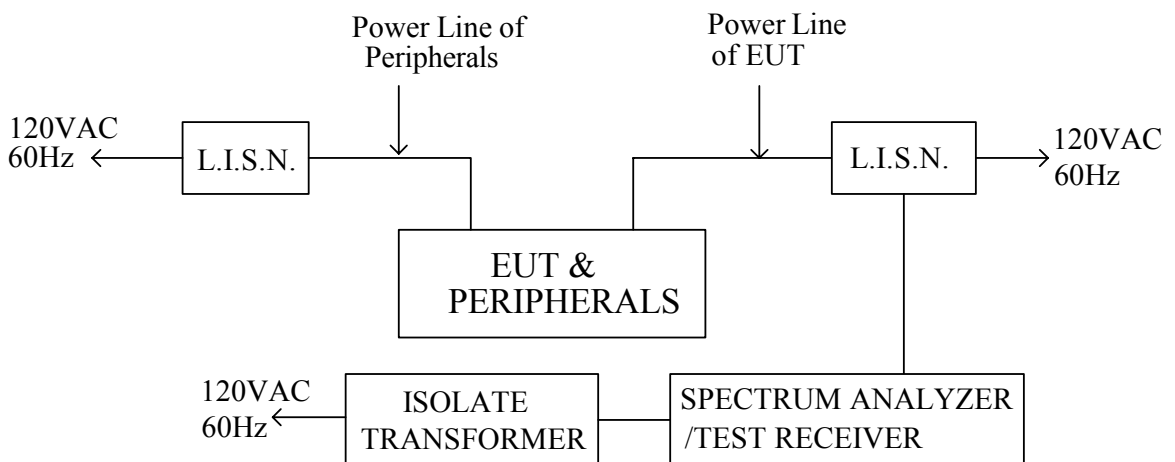



### 2.3 Conducted Power Line Emission Limit

For unintentional device, according to § 15.107(a) Line Conducted Emission Limits is as following :

| Frequency (MHz) | Maximum RF Line Voltage (dB $\mu$ v) |      |         |       |
|-----------------|--------------------------------------|------|---------|-------|
|                 | CLASS A                              |      | CLASS B |       |
|                 | Q.P.                                 | Ave. | Q.P.    | Ave.  |
| 0.15 - 0.50     | 79                                   | 66   | 66-56   | 56-46 |
| 0.50 - 5.00     | 73                                   | 60   | 56      | 46    |
| 5.00 - 30.0     | 73                                   | 60   | 60      | 50    |

For intentional device, according to § 15.207(a) Line Conducted Emission Limit is same as above table.

### 2.4 Test Procedure

The test procedure is performed in a 12ft×12ft×8ft(L×W×H) shielded room. The EUT along with its peripherals were placed on a 1.0m(W)× 1.5m(L) and 0.8m in height wooden table and the EUT was adjusted to maintain a 0.4 meter space from a vertical reference plane. The EUT was connected to power mains through a line impedance stabilization network (LISN) which provides 50 ohm coupling impedance for measuring instrument and the chasis ground was bounded to the horizontal ground plane of shielded room. All peripherals were connected to the second LISN and the chasis ground also bounded to the horizontal ground plane of shielded room. The excess power cable between the EUT and the LISN was bundled. The power cables of peripherals were unbundled. All connecting cables of EUT and peripherals were moved to find the maximum emission.

### 2.5 Uncertainty of Conducted Emission

The uncertainty of conducted emission is ±1.36dB.



## 2.6 Conducted RF Voltage Measurement

The frequency spectrum from 0.15 MHz to 30 MHz was investigated. All emissions not reported are much lower than the prescribed limits.

|                     |   |                            |             |
|---------------------|---|----------------------------|-------------|
| <b>Company</b>      | Netgear Incorporated                            | <b>Test Date</b>           | 2004/11/22  |
| <b>Product Name</b> | Double 108 Mbps Wireless USB 2.0 Adapter WG111U | <b>Test By</b>             | Alan Fan    |
| <b>Model Name</b>   | WG111U  | <b>TEMP &amp; Humidity</b> | 20.3°C, 79% |

LINE

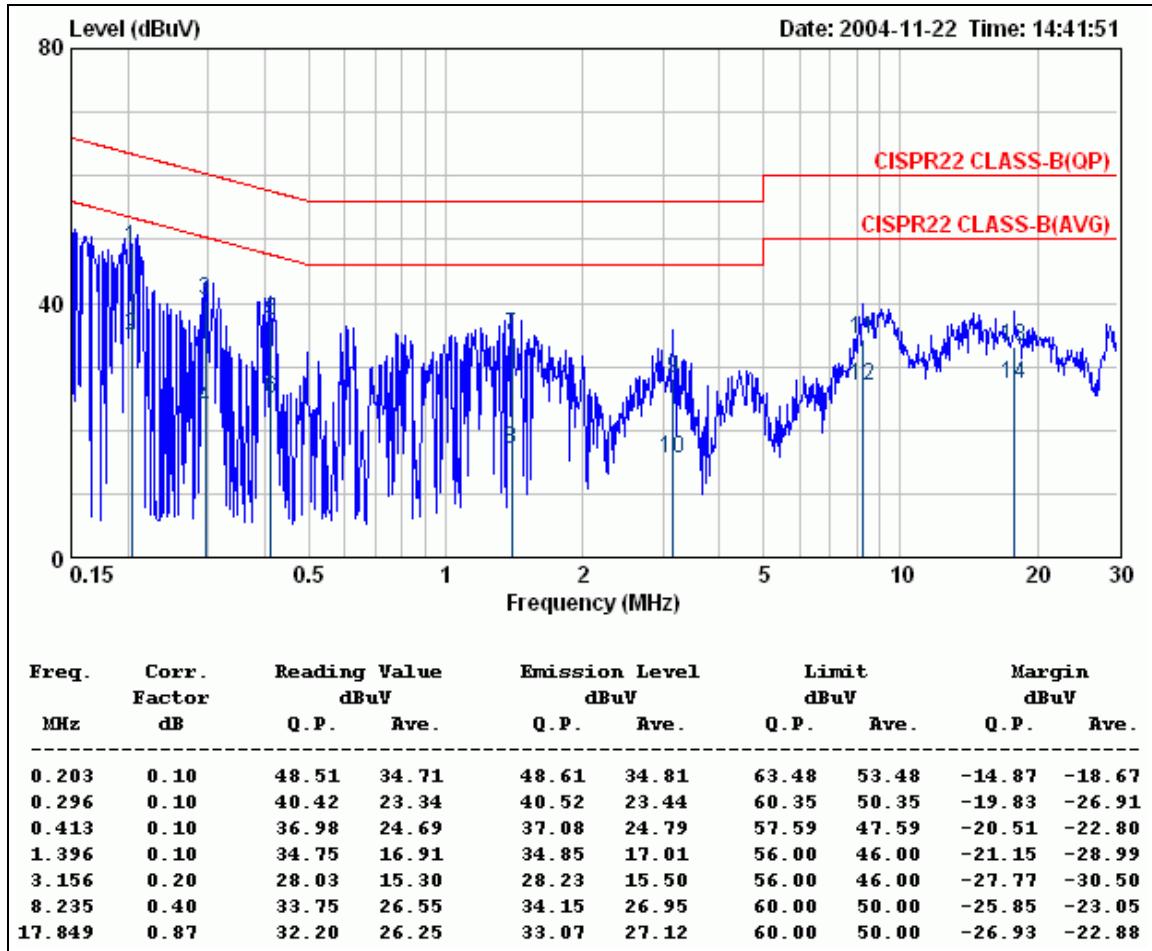

REMARKS :

1. Correction Factor = Insertion loss + cable loss
2. Margin value = Emission level – Limit value
3. The EUT can be operated in transmitting, receiveing and standby modes.  
 According to technical experiences, the power line emissions of the EUT in transmitting mode generate highest emission. The EUT was set to transmitting mode at channel 1 (5180MHz) to get the worst-case data while performing finial test.



**Ecom Sertech Corp.**

Rm. 258, Bldg. 17, NO.195, Sec.4 Chung Hsing Rd., ChuTugn Chen, Hsinchu, Taiwan 310, R.O.C  
 TEL: 886-3-5918012 FAX: 886-3-5825720

FCC ID : PY3WG111U

Report No. : ER04-11-043FRFa

Page 13 of 84

The frequency spectrum from 0.15 MHz to 30 MHz was investigated. All emissions not reported are much lower than the prescribed limits.

|                     |   |                            |             |
|---------------------|---|----------------------------|-------------|
| <b>Company</b>      | Netgear Incorporated                            | <b>Test Date</b>           | 2004/11/22  |
| <b>Product Name</b> | Double 108 Mbps Wireless USB 2.0 Adapter WG111U | <b>Test By</b>             | Alan Fan    |
| <b>Model Name</b>   | WG111U  | <b>TEMP &amp; Humidity</b> | 20.3°C, 79% |

NEUTRAL

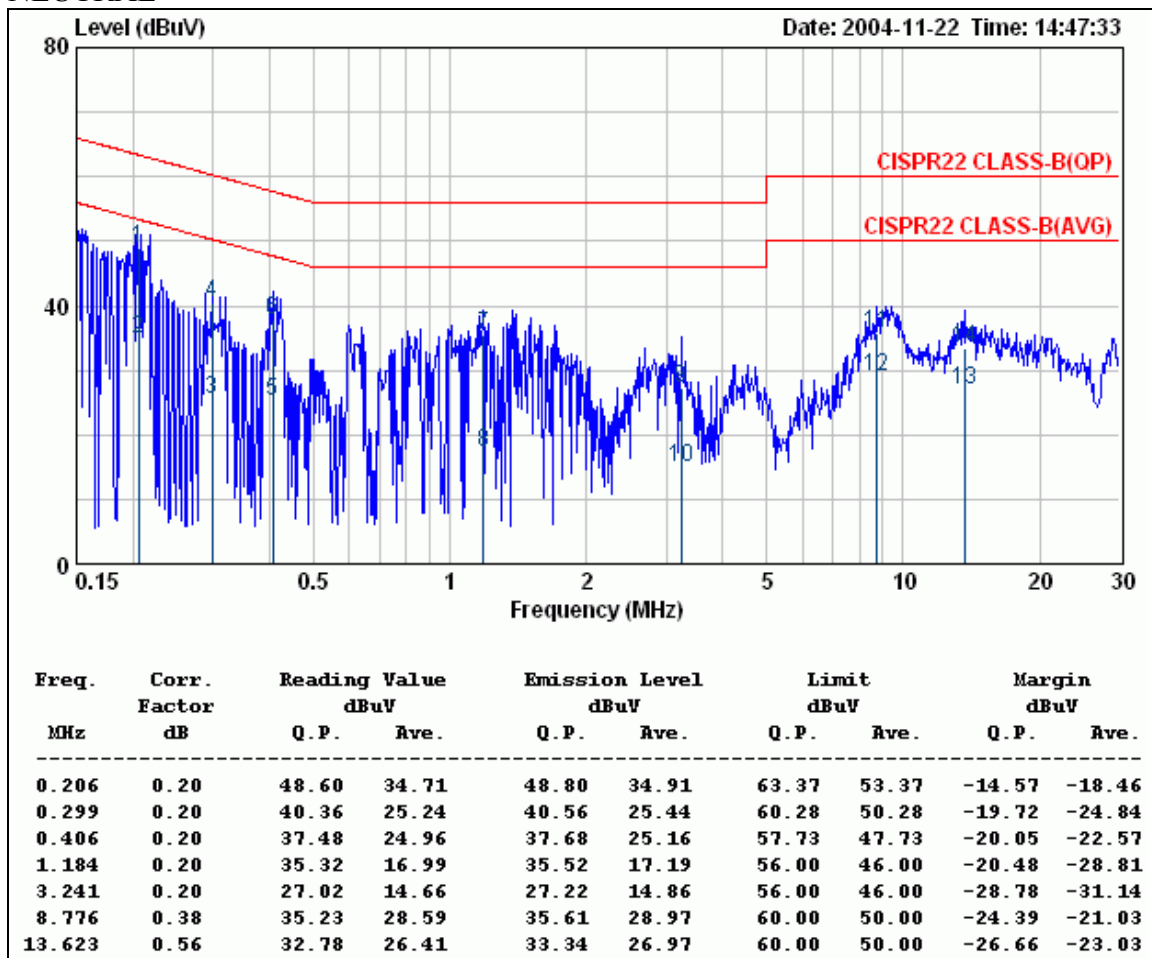

REMARKS :

1. Correction Factor = Insertion loss + cable loss
2. Margin value = Emission level – Limit value
3. The EUT can be operated in transmitting, receiveing and standby modes.  
 According to technical experiences, the power line emissions of the EUT in transmitting mode generate highest emission. The EUT was set to transmitting mode at channel 1 (5180MHz) to get the worst-case data while performing finial test.

## 2.7 Photos of Conduction Test

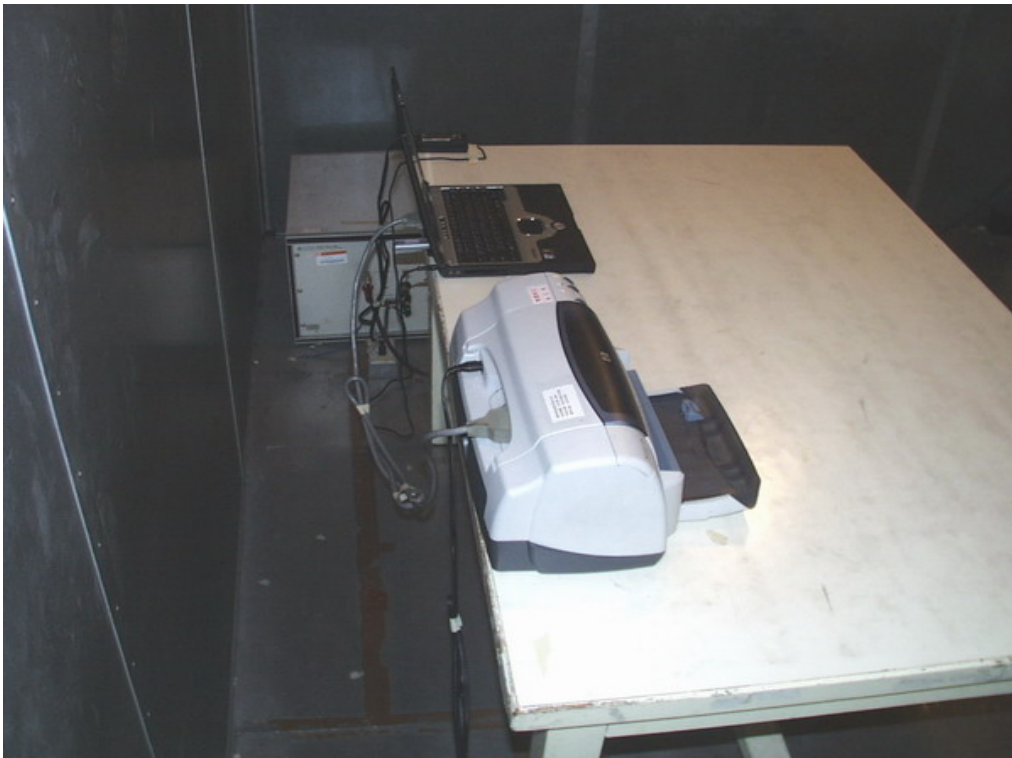



### 3. RADIATED EMISSION TEST

#### 3.1 Test Equipments

The following test equipments are utilized in making the measurements contained in this report.

| Manufacturer or Type         | Model No         | Serial No  | Date of Calibration | Calibration Period | Remark |
|------------------------------|------------------|------------|---------------------|--------------------|--------|
| CHASE BI-LOG ANTENNA         | CBL6112B         | 2421       | June 15, 2004       | 1 Year             | FINAL  |
| R/S SPECTRUM ANALYZER        | FSEK30           | 835253/002 | September 06, 2004  | 1 Year             | FINAL  |
| R/S EMI TEST RECEIVER        | ESCS30           | 83548/008  | September 05, 204   | 1 Year             | FINAL  |
| OPEN SITE                    | -----            | No.2       | May 07, 2004        | 1 Year             | FINAL  |
| N TYPE COAXIAL CABLE         | CHA9525          | 4          | June 03, 2004       | 1 Year             | FINAL  |
| Com-power Horn Antenna       | AH-118           | 10089      | April 09, 2004      | 1 Year             | FINAL  |
| HP Pre-amplifier             | 8449B            | 3008A01471 | November 24, 2004   | 1 Year             | FINAL  |
| NardaMicrowave Pre-amplifier | DBS-1840N8<br>13 | 016        | July 27, 2004       | 1 Year             | FINAL  |
| HP High pass filter          | 84300/80038      | 002        | CAL. ON USE         | 1 Year             | FINAL  |
| HP High pass filter          | 84300/80039      | 003        | CAL. ON USE         | 1 Year             | FINAL  |
| Com-Power Horn Antenna       | AH-840           | 3077       | February 25, 2004   | 1 Year             | FINAL  |

### 3.2 Test Setup

The diagram below shows the test setup that is utilized to make the measurements for emission below 1GHz.

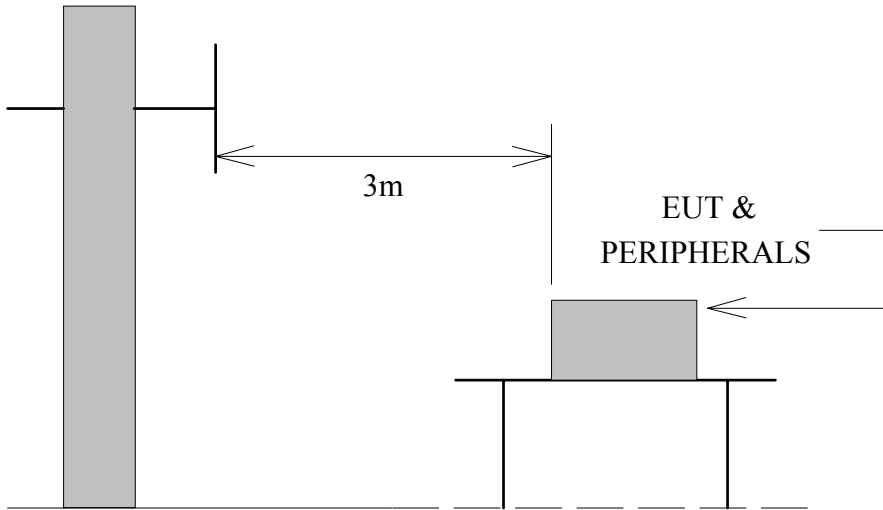

Antenna Elevation Variable

The diagram below shows the test setup that is utilized to make the measurements for emission above 1GHz.

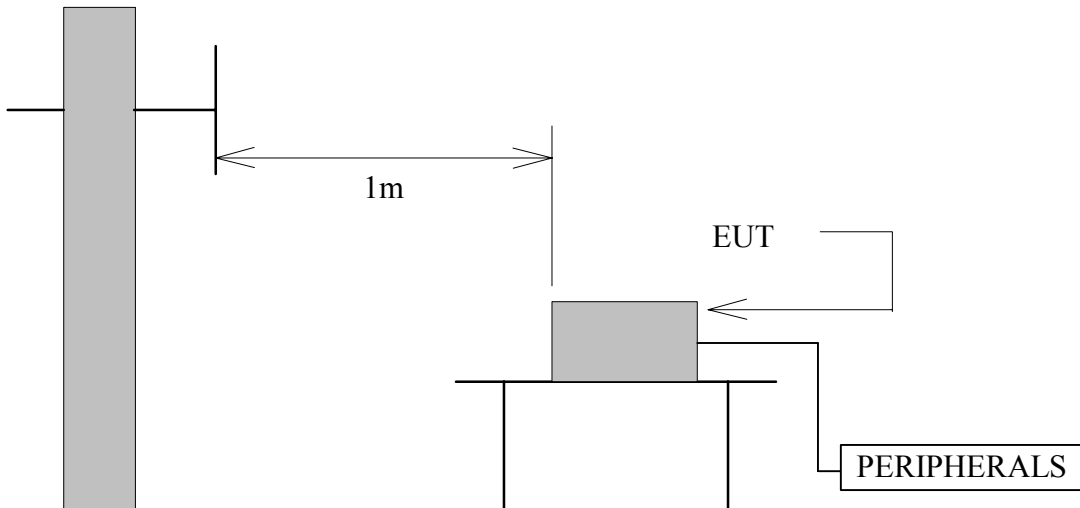

Antenna Elevation Variable





### 3.3 Radiation Limit

According to FCC Section 15.407(b) (6) (7), the unwanted emission below 1 GHz and in restricted bands should comply with the general field strength limits set forth in Section 15.209.

| Frequency (MHz) | Distance (Meters) | Radiated (dBμV/M) |
|-----------------|-------------------|-------------------|
| 30-88           | 3                 | 40.0              |
| 88-216          | 3                 | 43.5              |
| 216-960         | 3                 | 46.0              |
| Above 960       | 3                 | 54.0              |

For intentional device, according to § 15.209(a), the general requirement of field strength of radiated emissions from intentional radiators at a distance of 3 meters shall not exceed the above table.

According to FCC Section 15.407(b)(1) (2) (3) (4), the unwanted emission above 1 GHz, outside of the operating frequency band below, should exceed an EIRP of the values listed in table below.

| Operating Frequency Band (MHz) | EIRP Limit (dBm/MHz) | Equivalent Field Strength at 3m (dBμV/M) |
|--------------------------------|----------------------|--|
| 5150-5250                      | -27                  | 68.3                                     |
| 5250-5350                      | -27                  | 68.3                                     |
| 5470-5725                      | -27                  | 68.3                                     |
| 5725-5825                      | -27*                 | 68.3                                     |
|                                | -17**                | 78.3                                     |

The remark “\*” means: outside the frequency range 5715~5835MHz.

The remark “\*\*” means: within the frequency range from the band edge to 10MHz below or above the band edge, 5715~5725MHz and 5825~5835MHz.



### 3.4 Test Procedures

- a. The EUT was placed on the top of a rotating table 0.8 meters above the ground at a 10 meter open area test site. The table was rotated 360 degrees to determine the position of the highest radiation.
- b. During performing radiated emission below 1GHz, the EUT was set 3 meters away from the interference-receiving antenna, which was mounted on the top of a variable-height antenna tower. During performing radiated emission above 1GHz, the EUT was set 1 meters away from the interference-receiving antenna.
- c. The antenna is a broadband antenna, and its height is varied from one meter to four meters above the ground to determine the maximum value of the field strength. Both horizontal and vertical polarization of the antenna are set to make the measurement.
- d. For each suspected emission, the EUT was arranged to its worst case and then the antenna was tuned to heights from 1 meter to 4 meters and the table was turned from 0 degrees to 360 degrees to find the maximum reading.
- e. The test-receiver system was set to Peak Detect Function and Specified Bandwidth with Maximum Hold Mode.
- f. If the emission level of the EUT in peak mode was 10 dB lower than the limit specified, then testing could be stopped and the peak values of the EUT would be reported. Otherwise the emissions that did not have 10 dB margin would be re-tested one by one using peak, quasi-peak or average method as specified and then reported in a data sheet.

NOTE :

1. The resolution bandwidth and video bandwidth of test receiver/spectrum analyzer is 120 KHz for Peak detection (PK) and Quasi-peak detection (QP) at frequency below 1GHz.
2. The resolution bandwidth and video bandwidth of test receiver/spectrum analyzer is 1 MHz for Peak detection and frequency above 1GHz.
3. The resolution bandwidth of test receiver/spectrum analyzer is 1 MHz and the video bandwidth is 10 Hz for Average detection (AV) at frequency above 1GHz.

### 3.5 Uncertainty of Radiated Emission

The uncertainty of radiated emission is  $\pm 2.72$ dB.



### 3.6 Radiated RF Noise Measurement

#### 3.6.1 Spurious Emission Below 1GHz

The frequency spectrum from 30 MHz to 1000 MHz was investigated. All emissions not reported are much lower than the prescribed limits.

All readings are quasi-peak values.

|                     |   |                            |             |
|---------------------|---|----------------------------|-------------|
| <b>Company</b>      | Netgear Incorporated                            | <b>Test Date</b>           | 2004/11/22  |
| <b>Product Name</b> | Double 108 Mbps Wireless USB 2.0 Adapter WG111U | <b>Test By</b>             | Alan Fan    |
| <b>Model Name</b>   | WG111U  | <b>TEMP &amp; Humidity</b> | 20.0°C, 70% |

| Frequency (MHz) | Antenna Factor (dB/m) | Cable Loss (dB) | Meter Reading at 3m(dBμV) |          | Limits (dBμV/m) | Emission Level at 3m(dBμV/m) |          |
|-----------------|-----------------------|-----------------|---------------------------|----------|-----------------|------------------------------|----------|
|                 |                       |                 | Horizontal                | Vertical |                 | Horizontal                   | Vertical |
| 30.00           | 17.01                 | 0.97            | *                         | *        | 40.00           | *                            | *        |
| 200.00          | 9.80                  | 3.14            | 10.70                     | 8.90     | 43.50           | 23.64                        | 21.84    |
| 250.00          | 12.72                 | 4.01            | 4.30                      | 2.90     | 46.00           | 21.03                        | 19.63    |
| 279.99          | 13.19                 | 4.18            | 5.20                      | 2.60     | 46.00           | 22.58                        | 19.98    |
| 299.99          | 13.51                 | 4.30            | 4.90                      | 5.70     | 46.00           | 22.71                        | 23.51    |
| 400.00          | 18.41                 | 4.85            | 4.90                      | 4.80     | 46.00           | 28.16                        | 28.06    |
| 479.98          | 17.95                 | 5.12            | 6.70                      | 5.00     | 46.00           | 29.77                        | 28.07    |
| 701.99          | 19.52                 | 6.28            | 12.80                     | 17.20    | 46.00           | 38.60                        | 43.00    |
| 1000.00         | 27.43                 | 7.66            | *                         | *        | 54.00           | *                            | *        |

REMARKS :

- \* Undetectable
- Emission level (dBμV/m) = Antenna Factor (dB/m) + Cable loss (dB) + Meter Reading (dBμV).
- The EUT can be operated in transmitting, receiveing and standby modes. According to technical experiences, the emissions of the EUT in transmitting mode generate highest spurious emission below 1GHz. The EUT was set to transmitting mode at channel 1 (5180MHz) to get the worst-case data while performing finial test below 1GHz.



### 3.6.2 Spurious Emission Outside of the 5.15 ~ 5.35GHz Band (TX)

The frequency spectrum above 1 GHz for Transmitter was investigated. All emissions not reported are much lower than the prescribed limits. Readings are both peak and average values.

|                     |   |                            |             |
|---------------------|---|----------------------------|-------------|
| <b>Company</b>      | Netgear Incorporated                            | <b>Test Date</b>           | 2004/11/24  |
| <b>Product Name</b> | Double 108 Mbps Wireless USB 2.0 Adapter WG111U | <b>Test By</b>             | Alan Fan    |
| <b>Model Name</b>   | WG111U  | <b>TEMP &amp; Humidity</b> | 30.4°C, 54% |

| CH1 (5180MHz) TX |                |           |            | Measurement Distance at 1m Horizontal polarity |           |             |                |                       |             |              |                |
|------------------|----------------|-----------|------------|--|-----------|-------------|----------------|-----------------------|-------------|--------------|----------------|
| Freq. (MHz)      | Reading (dBμV) | AF (dBμV) | Cable (dB) | Pre-amp (dB)                                   | Dist (dB) | Filter (dB) | Level (dBμV/m) | Limit (dBμV/m)        | Margin (dB) | Mark (P/Q/A) | Height (Meter) |
| 3453.26          | 48.77          | 31.43     | 4.28       | 35.45  | 9.50      | 0.00        | 39.54          | 88.30                 | -48.76      | P            | 1.24           |
| 3453.26          | 42.70          | 31.43     | 4.28       | 35.45  | 9.50      | 0.00        | 33.47          | 68.30                 | -34.83      | A            | 1.24           |
| * 5149.72        | 29.60          | 35.81     | 5.33       | 0.00   | 9.50      | 0.00        | 61.24          | 74.00                 | -12.76      | P            | 1.05           |
| * 5149.72        | 15.41          | 35.81     | 5.33       | 0.00   | 9.50      | 0.00        | 47.05          | 54.00                 | -6.95       | A            | 1.05           |
| 5184.70          | 74.26          | 35.86     | 5.37       | 0.00   | 9.50      | 0.00        | 105.99         | Fundamental Frequency |             | P            | 1.00           |
| 5184.70          | 64.79          | 35.86     | 5.37       | 0.00   | 9.50      | 0.00        | 96.52          |                       |             | A            | 1.00           |
| 6906.58          | 46.99          | 39.56     | 6.56       | 35.44  | 9.50      | 2.04        | 50.22          | 88.30                 | -38.08      | P            | 1.11           |
| 6906.58          | 39.73          | 39.56     | 6.56       | 35.44  | 9.50      | 2.04        | 42.96          | 68.30                 | -25.34      | A            | 1.11           |
| 10359.49         | 67.01          | 38.93     | 8.53       | 36.21  | 9.50      | 0.54        | 69.30          | 88.30                 | -19.00      | P            | 1.00           |
| 10359.49         | 56.46          | 38.93     | 8.53       | 36.21  | 9.50      | 0.54        | 58.75          | 68.30                 | -9.55       | A            | 1.00           |
| * 15558.63       | 45.76          | 45.09     | 8.74       | 35.79  | 9.50      | 0.30        | 54.60          | 74.00                 | -19.40      | P            | 1.03           |
| * 15558.63       | 34.28          | 45.09     | 8.74       | 35.79  | 9.50      | 0.30        | 43.12          | 54.00                 | -10.88      | A            | 1.03           |
| * 20738.80       | -----          | -----     | -----      | -----  | 9.50      | 5.10        | -----          | -----                 | -----       | -----        | 1.00           |
| 25923.50         | -----          | -----     | -----      | -----  | 9.50      | 1.58        | -----          | -----                 | -----       | -----        | 1.00           |
| 31108.20         | -----          | -----     | -----      | -----  | 9.50      | 0.00        | -----          | -----                 | -----       | -----        | 1.00           |
| 36292.90         | -----          | -----     | -----      | -----  | 9.50      | 0.00        | -----          | -----                 | -----       | -----        | 1.00           |
| * 41477.60       | -----          | -----     | -----      | -----  | 9.50      | 0.00        | -----          | -----                 | -----       | -----        | 1.00           |
| * 46662.30       | -----          | -----     | -----      | -----  | 9.50      | 0.00        | -----          | -----                 | -----       | -----        | 1.00           |
| * 51847.00       | -----          | -----     | -----      | -----  | 9.50      | 0.00        | -----          | -----                 | -----       | -----        | 1.00           |

Note :

- The measurement was searched to 10th harmonic, Remark “---” means that the emissions level is too low to be measured.
- AF: Antenna Factor, Cable: Cable Loss, Pre-Amp: Preamplifier gain, Filter: High Pass Filter Insertion Loss (8.2GHz)
- Spectrum analyzer setting P(Peak): RBW=1MHz, VBW=1MHz, A(Average): RBW=1MHz, VBW=10Hz
- Remark “\*” means the Restricted band.
- Dist : correction to extra plate reading to 3m specification distance 1m measurement distance = -9.5dB
- The result basic equation calculation is as follow:  
 Level = Reading + AF + Cable - Preamp + Filter - Dist, Margin = Level - Limit
- The test limit distance is 3M limit.
- For normal 802.11a mode.



**Ecom Sertech Corp.**

Rm. 258, Bldg. 17, NO.195, Sec.4 Chung Hsing Rd., ChuTugn Chen, Hsinchu, Taiwan 310, R.O.C  
 TEL: 886-3-5918012 FAX: 886-3-5825720

FCC ID : PY3WG111U

Report No. : ER04-11-043FRFa

Page 21 of 84

The frequency spectrum above 1 GHz for Transmitter was investigated. All emissions not reported are much lower than the prescribed limits. Readings are both peak and average values.

|                     |   |                            |             |
|---------------------|---|----------------------------|-------------|
| <b>Company</b>      | Netgear Incorporated                            | <b>Test Date</b>           | 2004/11/24  |
| <b>Product Name</b> | Double 108 Mbps Wireless USB 2.0 Adapter WG111U | <b>Test By</b>             | Alan Fan    |
| <b>Model Name</b>   | WG111U  | <b>TEMP &amp; Humidity</b> | 30.4°C, 54% |

| CH1 (5180MHz) TX |                |           |            | Measurement Distance at 1m Vertical polarity |           |             |                |                       |             |              |                |
|------------------|----------------|-----------|------------|--|-----------|-------------|----------------|-----------------------|-------------|--------------|----------------|
| Freq. (MHz)      | Reading (dBμV) | AF (dBμV) | Cable (dB) | Pre-amp (dB)                                 | Dist (dB) | Filter (dB) | Level (dBμV/m) | Limit (dBμV/m)        | Margin (dB) | Mark (P/Q/A) | Height (Meter) |
| 3453.18          | 52.64          | 31.43     | 4.28       | 35.45  | 9.50      | 0.00        | 43.41          | 88.30                 | -44.89      | P            | 1.00           |
| 3453.18          | 48.51          | 31.43     | 4.28       | 35.45  | 9.50      | 0.00        | 39.28          | 68.30                 | -29.02      | A            | 1.00           |
| * 5149.72        | 28.13          | 35.81     | 5.33       | 0.00   | 9.50      | 0.00        | 59.77          | 74.00                 | -14.23      | P            | 1.00           |
| * 5149.72        | 15.41          | 35.81     | 5.33       | 0.00   | 9.50      | 0.00        | 47.05          | 54.00                 | -6.95       | A            | 1.00           |
| 5184.10          | 66.80          | 35.86     | 5.37       | 0.00   | 9.50      | 0.00        | 98.53          | Fundamental Frequency |             | P            | 1.00           |
| 5184.10          | 57.01          | 35.86     | 5.37       | 0.00   | 9.50      | 0.00        | 88.74          |                       |             | A            | 1.00           |
| 6906.76          | 48.63          | 39.56     | 6.56       | 35.44  | 9.50      | 0.00        | 49.82          | 88.30                 | -38.48      | P            | 1.00           |
| 6906.76          | 41.43          | 39.56     | 6.56       | 35.44  | 9.50      | 0.00        | 42.62          | 68.30                 | -25.68      | A            | 1.00           |
| 10359.55         | 66.70          | 38.93     | 8.53       | 36.21  | 9.50      | 0.54        | 68.99          | 88.30                 | -19.31      | P            | 1.11           |
| 10359.55         | 55.94          | 38.93     | 8.53       | 36.21  | 9.50      | 0.54        | 58.23          | 68.30                 | -10.07      | A            | 1.11           |
| * 15536.09       | 46.01          | 45.17     | 8.72       | 35.75  | 9.50      | 0.30        | 54.95          | 74.00                 | -19.05      | P            | 1.00           |
| * 15536.09       | 33.94          | 45.17     | 8.72       | 35.75  | 9.50      | 0.30        | 42.88          | 54.00                 | -11.12      | A            | 1.00           |
| * 20736.40       | -----          | -----     | -----      | -----  | 9.50      | 5.09        | -----          | -----                 | -----       | -----        | 1.00           |
| 25920.50         | -----          | -----     | -----      | -----  | 9.50      | 1.58        | -----          | -----                 | -----       | -----        | 1.00           |
| 31104.60         | -----          | -----     | -----      | -----  | 9.50      | 0.00        | -----          | -----                 | -----       | -----        | 1.00           |
| 36288.70         | -----          | -----     | -----      | -----  | 9.50      | 0.00        | -----          | -----                 | -----       | -----        | 1.00           |
| * 41472.80       | -----          | -----     | -----      | -----  | 9.50      | 0.00        | -----          | -----                 | -----       | -----        | 1.00           |
| * 46656.90       | -----          | -----     | -----      | -----  | 9.50      | 0.00        | -----          | -----                 | -----       | -----        | 1.00           |
| * 51841.00       | -----          | -----     | -----      | -----  | 9.50      | 0.00        | -----          | -----                 | -----       | -----        | 1.00           |

- Note :
- The measurement was searched to 10th harmonic, Remark “---” means that the emissions level is too low to be measured.
  - AF: Antenna Factor, Cable: Cable Loss, Pre-Amp: Preamplifier gain, Filter: High Pass Filter Insertion Loss (8.2GHz)
  - Spectrum analyzer setting P(Peak): RBW=1MHz, VBW=1MHz, A(Average): RBW=1MHz, VBW=10Hz
  - Remark “\*” means the Restricted band.
  - Dist : correction to extra plate reading to 3m specification distance 1m measurement distance = -9.5dB
  - The result basic equation calculation is as follow:  
 $Level = Reading + AF + Cable - Preamp + Filter - Dist$ ,  $Margin = Level - Limit$
  - The test limit distance is 3M limit.
  - For normal 802.11a mode.



# Ecom Sertech Corp.

Rm. 258, Bldg. 17, NO.195, Sec.4 Chung Hsing Rd., ChuTugn Chen, Hsinchu, Taiwan 310, R.O.C  
 TEL: 886-3-5918012 FAX: 886-3-5825720

FCC ID : PY3WG111U

Report No. : ER04-11-043FRFa

Page 22 of 84

The frequency spectrum above 1 GHz for Transmitter was investigated. All emissions not reported are much lower than the prescribed limits. Readings are both peak and average values.

|                     |   |                            |             |
|---------------------|---|----------------------------|-------------|
| <b>Company</b>      | Netgear Incorporated                            | <b>Test Date</b>           | 2004/11/24  |
| <b>Product Name</b> | Double 108 Mbps Wireless USB 2.0 Adapter WG111U | <b>Test By</b>             | Alan Fan    |
| <b>Model Name</b>   | WG111U  | <b>TEMP &amp; Humidity</b> | 30.4°C, 54% |

| CH4 (5240MHz) TX |                |           |            | Measurement Distance at 1m Horizontal polarity |           |             |                |                |             |              |                |
|------------------|----------------|-----------|------------|--|-----------|-------------|----------------|----------------|-------------|--------------|----------------|
| Freq. (MHz)      | Reading (dBμV) | AF (dBμV) | Cable (dB) | Pre-amp (dB)                                   | Dist (dB) | Filter (dB) | Level (dBμV/m) | Limit (dBμV/m) | Margin (dB) | Mark (P/Q/A) | Height (Meter) |
| 3493.33          | 49.43          | 31.40     | 4.32       | 35.41  | 9.50      | 0.00        | 40.25          | 88.30          | -48.05      | P            | 1.20           |
| 3493.33          | 43.85          | 31.40     | 4.32       | 35.41  | 9.50      | 0.00        | 34.67          | 68.30          | -33.63      | A            | 1.20           |
| 6986.55          | 48.93          | 39.85     | 6.58       | 35.66  | 9.50      | 0.00        | 50.20          | 88.30          | -38.10      | P            | 1.08           |
| 6986.55          | 43.35          | 39.85     | 6.58       | 35.66  | 9.50      | 0.00        | 44.62          | 68.30          | -23.68      | A            | 1.08           |
| 10479.45         | 63.44          | 39.08     | 8.56       | 35.95  | 9.50      | 0.59        | 66.23          | 88.30          | -22.07      | P            | 1.00           |
| 10479.45         | 52.23          | 39.08     | 8.56       | 35.95  | 9.50      | 0.59        | 55.02          | 68.30          | -13.28      | A            | 1.00           |
| * 15720.00       | 45.81          | 44.51     | 8.84       | 36.03  | 9.50      | 0.30        | 53.92          | 74.00          | -20.08      | P            | 1.00           |
| * 15720.00       | 34.48          | 44.51     | 8.84       | 36.03  | 9.50      | 0.30        | 42.59          | 54.00          | -11.41      | A            | 1.00           |
| * 20958.90       | -----          | -----     | -----      | -----  | 9.50      | 5.82        | -----          | -----          | -----       | -----        | 1.00           |
| 26198.63         | -----          | -----     | -----      | -----  | 9.50      | 1.80        | -----          | -----          | -----       | -----        | 1.00           |
| * 31438.35       | -----          | -----     | -----      | -----  | 9.50      | 0.00        | -----          | -----          | -----       | -----        | 1.00           |
| 36678.08         | -----          | -----     | -----      | -----  | 9.50      | 0.00        | -----          | -----          | -----       | -----        | 1.00           |
| * 41917.80       | -----          | -----     | -----      | -----  | 9.50      | 0.00        | -----          | -----          | -----       | -----        | 1.00           |
| * 47157.53       | -----          | -----     | -----      | -----  | 9.50      | 0.00        | -----          | -----          | -----       | -----        | 1.00           |
| * 52397.25       | -----          | -----     | -----      | -----  | 9.50      | 0.00        | -----          | -----          | -----       | -----        | 1.00           |

Note :

- The measurement was searched to 10th harmonic, Remark “---” means that the emissions level is too low to be measured.
- AF: Antenna Factor, Cable: Cable Loss, Pre-Amp: Preamplifier gain, Filter: High Pass Filter Insertion Loss (8.2GHz)
- Spectrum analyzer setting P(Peak): RBW=1MHz, VBW=1MHz, A(Average): RBW=1MHz, VBW=10Hz
- Remark “\*” means the Restricted band.
- Dist : correction to extra plate reading to 3m specification distance 1m measurement distance = -9.5dB
- The result basic equation calculation is as follow:  
 $Level = Reading + AF + Cable - Preamp + Filter - Dist$ ,  $Margin = Level - Limit$
- The test limit distance is 3M limit.
- For normal 802.11a mode.



**Ecom Sertech Corp.**

Rm. 258, Bldg. 17, NO.195, Sec.4 Chung Hsing Rd., ChuTugn Chen, Hsinchu, Taiwan 310, R.O.C  
 TEL: 886-3-5918012 FAX: 886-3-5825720

FCC ID : PY3WG111U

Report No. : ER04-11-043FRFa

Page 23 of 84

The frequency spectrum above 1 GHz for Transmitter was investigated. All emissions not reported are much lower than the prescribed limits. Readings are both peak and average values.

|                     |   |                            |             |
|---------------------|---|----------------------------|-------------|
| <b>Company</b>      | Netgear Incorporated                            | <b>Test Date</b>           | 2004/11/24  |
| <b>Product Name</b> | Double 108 Mbps Wireless USB 2.0 Adapter WG111U | <b>Test By</b>             | Alan Fan    |
| <b>Model Name</b>   | WG111U  | <b>TEMP &amp; Humidity</b> | 30.4°C, 54% |

| CH4 (5240MHz) TX |                |           |            | Measurement Distance at 1m Vertical polarity |           |             |                |                |             |              |                |
|------------------|----------------|-----------|------------|--|-----------|-------------|----------------|----------------|-------------|--------------|----------------|
| Freq. (MHz)      | Reading (dBμV) | AF (dBμV) | Cable (dB) | Pre-amp (dB)                                 | Dist (dB) | Filter (dB) | Level (dBμV/m) | Limit (dBμV/m) | Margin (dB) | Mark (P/Q/A) | Height (Meter) |
| 3493.25          | 52.09          | 31.40     | 4.32       | 35.41  | 9.50      | 0.00        | 42.91          | 88.30          | -45.39      | P            | 1.13           |
| 3493.25          | 48.16          | 31.40     | 4.32       | 35.41  | 9.50      | 0.00        | 38.98          | 68.30          | -29.32      | A            | 1.13           |
| 6986.69          | 47.63          | 39.85     | 6.58       | 35.66  | 9.50      | 0.00        | 48.90          | 88.30          | -39.40      | P            | 1.14           |
| 6986.69          | 41.52          | 39.85     | 6.58       | 35.66  | 9.50      | 0.00        | 42.79          | 68.30          | -25.51      | A            | 1.14           |
| 10480.00         | 59.36          | 39.08     | 8.56       | 35.94  | 9.50      | 0.59        | 62.15          | 88.30          | -26.15      | P            | 1.00           |
| 10480.00         | 48.40          | 39.08     | 8.56       | 35.94  | 9.50      | 0.59        | 51.19          | 68.30          | -17.11      | A            | 1.00           |
| * 15720.00       | 46.48          | 44.51     | 8.84       | 36.03  | 9.50      | 0.30        | 54.59          | 74.00          | -19.41      | P            | 1.00           |
| * 15720.00       | 35.34          | 44.51     | 8.84       | 36.03  | 9.50      | 0.30        | 43.45          | 54.00          | -10.55      | A            | 1.00           |
| * 20960.00       | -----          | -----     | -----      | -----  | 9.50      | 5.82        | -----          | -----          | -----       | -----        | 1.00           |
| 26200.00         | -----          | -----     | -----      | -----  | 9.50      | 1.80        | -----          | -----          | -----       | -----        | 1.00           |
| * 31440.00       | -----          | -----     | -----      | -----  | 9.50      | 0.00        | -----          | -----          | -----       | -----        | 1.00           |
| 36680.00         | -----          | -----     | -----      | -----  | 9.50      | 0.00        | -----          | -----          | -----       | -----        | 1.00           |
| * 41920.00       | -----          | -----     | -----      | -----  | 9.50      | 0.00        | -----          | -----          | -----       | -----        | 1.00           |
| * 47160.00       | -----          | -----     | -----      | -----  | 9.50      | 0.00        | -----          | -----          | -----       | -----        | 1.00           |
| * 52400.00       | -----          | -----     | -----      | -----  | 9.50      | 0.00        | -----          | -----          | -----       | -----        | 1.00           |

Note :

- The measurement was searched to 10th harmonic, Remark “---” means that the emissions level is too low to be measured.
- AF: Antenna Factor, Cable: Cable Loss, Pre-Amp: Preamplifier gain, Filter: High Pass Filter Insertion Loss (8.2GHz)
- Spectrum analyzer setting P(Peak): RBW=1MHz, VBW=1MHz, A(Average): RBW=1MHz, VBW=10Hz
- Remark “\*” means the Restricted band.
- Dist : correction to extra plate reading to 3m specification distance 1m measurement distance = -9.5dB
- The result basic equation calculation is as follow:  
 Level = Reading + AF + Cable - Preamp + Filter - Dist, Margin = Level - Limit
- The test limit distance is 3M limit.
- For normal 802.11a mode.



**Ecom Sertech Corp.**

Rm. 258, Bldg. 17, NO.195, Sec.4 Chung Hsing Rd., ChuTugn Chen, Hsinchu, Taiwan 310, R.O.C  
 TEL: 886-3-5918012 FAX: 886-3-5825720

FCC ID : PY3WG111U

Report No. : ER04-11-043FRFa

Page 24 of 84

The frequency spectrum above 1 GHz for Transmitter was investigated. All emissions not reported are much lower than the prescribed limits. Readings are both peak and average values.

|                     |   |                            |             |
|---------------------|---|----------------------------|-------------|
| <b>Company</b>      | Netgear Incorporated                            | <b>Test Date</b>           | 2004/11/24  |
| <b>Product Name</b> | Double 108 Mbps Wireless USB 2.0 Adapter WG111U | <b>Test By</b>             | Alan Fan    |
| <b>Model Name</b>   | WG111U  | <b>TEMP &amp; Humidity</b> | 30.4°C, 54% |

| CH5 (5260MHz) TX |                |           |            | Measurement Distance at 1m Horizontal polarity |           |             |                |                |             |              |                |
|------------------|----------------|-----------|------------|--|-----------|-------------|----------------|----------------|-------------|--------------|----------------|
| Freq. (MHz)      | Reading (dBμV) | AF (dBμV) | Cable (dB) | Pre-amp (dB)                                   | Dist (dB) | Filter (dB) | Level (dBμV/m) | Limit (dBμV/m) | Margin (dB) | Mark (P/Q/A) | Height (Meter) |
| 3506.60          | 50.16          | 31.42     | 4.34       | 35.39  | 9.50      | 0.00        | 41.02          | 88.30          | -47.28      | P            | 1.22           |
| 3506.60          | 44.83          | 31.42     | 4.34       | 35.39  | 9.50      | 0.00        | 35.69          | 68.30          | -32.61      | A            | 1.22           |
| 7012.97          | 49.65          | 39.89     | 6.59       | 35.70  | 9.50      | 0.00        | 50.94          | 88.30          | -37.36      | P            | 1.10           |
| 7012.97          | 44.42          | 39.89     | 6.59       | 35.70  | 9.50      | 0.00        | 45.71          | 68.30          | -22.59      | A            | 1.10           |
| 10518.41         | 61.49          | 39.12     | 8.58       | 35.90  | 9.50      | 0.63        | 64.41          | 88.30          | -23.89      | P            | 1.08           |
| 10518.41         | 50.92          | 39.12     | 8.58       | 35.90  | 9.50      | 0.63        | 53.84          | 68.30          | -14.46      | A            | 1.08           |
| * 15781.17       | 45.25          | 44.29     | 8.87       | 36.12  | 9.50      | 0.30        | 53.09          | 74.00          | -20.91      | P            | 1.17           |
| * 15781.17       | 34.58          | 44.29     | 8.87       | 36.12  | 9.50      | 0.30        | 42.42          | 54.00          | -11.58      | A            | 1.17           |
| * 21036.82       | -----          | -----     | -----      | -----  | 9.50      | 5.58        | -----          | -----          | -----       | -----        | 1.00           |
| 26296.03         | -----          | -----     | -----      | -----  | 9.50      | 1.90        | -----          | -----          | -----       | -----        | 1.00           |
| * 31555.23       | -----          | -----     | -----      | -----  | 9.50      | 0.00        | -----          | -----          | -----       | -----        | 1.00           |
| 36814.44         | -----          | -----     | -----      | -----  | 9.50      | 0.00        | -----          | -----          | -----       | -----        | 1.00           |
| * 42073.64       | -----          | -----     | -----      | -----  | 9.50      | 0.00        | -----          | -----          | -----       | -----        | 1.00           |
| * 47332.85       | -----          | -----     | -----      | -----  | 9.50      | 0.00        | -----          | -----          | -----       | -----        | 1.00           |
| * 52592.05       | -----          | -----     | -----      | -----  | 9.50      | 0.00        | -----          | -----          | -----       | -----        | 1.00           |

Note :

- The measurement was searched to 10th harmonic, Remark “---” means that the emissions level is too low to be measured.
- AF: Antenna Factor, Cable: Cable Loss, Pre-Amp: Preamplifier gain, Filter: High Pass Filter Insertion Loss (8.2GHz)
- Spectrum analyzer setting P(Peak): RBW=1MHz, VBW=1MHz, A(Average): RBW=1MHz, VBW=10Hz
- Remark “\*” means the Restricted band.
- Dist : correction to extra plate reading to 3m specification distance 1m measurement distance = -9.5dB
- The result basic equation calculation is as follow:  
 Level = Reading + AF + Cable - Preamp + Filter - Dist, Margin = Level - Limit
- The test limit distance is 3M limit.
- For normal 802.11a mode.





**Ecom Sertech Corp.**

Rm. 258, Bldg. 17, NO.195, Sec.4 Chung Hsing Rd., ChuTugn Chen, Hsinchu, Taiwan 310, R.O.C  
 TEL: 886-3-5918012 FAX: 886-3-5825720

FCC ID : PY3WG111U

Report No. : ER04-11-043FRFa

Page 25 of 84

The frequency spectrum above 1 GHz for Transmitter was investigated. All emissions not reported are much lower than the prescribed limits. Readings are both peak and average values.

|                     |   |                            |             |
|---------------------|---|----------------------------|-------------|
| <b>Company</b>      | Netgear Incorporated                            | <b>Test Date</b>           | 2004/11/24  |
| <b>Product Name</b> | Double 108 Mbps Wireless USB 2.0 Adapter WG111U | <b>Test By</b>             | Alan Fan    |
| <b>Model Name</b>   | WG111U  | <b>TEMP &amp; Humidity</b> | 30.4°C, 54% |

| CH5 (5260MHz) TX |                |           |            | Measurement Distance at 1m Vertical polarity |           |             |                |                |             |              |                |
|------------------|----------------|-----------|------------|--|-----------|-------------|----------------|----------------|-------------|--------------|----------------|
| Freq. (MHz)      | Reading (dBμV) | AF (dBμV) | Cable (dB) | Pre-amp (dB)                                 | Dist (dB) | Filter (dB) | Level (dBμV/m) | Limit (dBμV/m) | Margin (dB) | Mark (P/Q/A) | Height (Meter) |
| 3506.70          | 51.96          | 31.42     | 4.34       | 35.39  | 9.50      | 0.00        | 42.82          | 88.30          | -45.48      | P            | 1.00           |
| 3506.70          | 47.95          | 31.42     | 4.34       | 35.39  | 9.50      | 0.00        | 38.81          | 68.30          | -29.49      | A            | 1.00           |
| 7013.18          | 48.58          | 39.89     | 6.59       | 35.70  | 9.50      | 0.00        | 49.87          | 88.30          | -38.43      | P            | 1.12           |
| 7013.18          | 42.50          | 39.89     | 6.59       | 35.70  | 9.50      | 0.00        | 43.79          | 68.30          | -24.51      | A            | 1.12           |
| 10519.67         | 60.81          | 39.12     | 8.58       | 35.90  | 9.50      | 0.63        | 63.74          | 88.30          | -24.56      | P            | 1.11           |
| 10519.67         | 50.04          | 39.12     | 8.58       | 35.90  | 9.50      | 0.63        | 52.97          | 68.30          | -15.33      | A            | 1.11           |
| * 15778.02       | 45.46          | 44.30     | 8.87       | 36.12  | 9.50      | 0.30        | 53.31          | 74.00          | -20.69      | P            | 1.16           |
| * 15778.02       | 34.44          | 44.30     | 8.87       | 36.12  | 9.50      | 0.30        | 42.29          | 54.00          | -11.71      | A            | 1.16           |
| * 21039.34       | -----          | -----     | -----      | -----  | 9.50      | 5.55        | -----          | -----          | -----       | -----        | 1.00           |
| 26299.18         | -----          | -----     | -----      | -----  | 9.50      | 1.90        | -----          | -----          | -----       | -----        | 1.00           |
| * 31559.01       | -----          | -----     | -----      | -----  | 9.50      | 0.00        | -----          | -----          | -----       | -----        | 1.00           |
| 36818.85         | -----          | -----     | -----      | -----  | 9.50      | 0.00        | -----          | -----          | -----       | -----        | 1.00           |
| * 42078.68       | -----          | -----     | -----      | -----  | 9.50      | 0.00        | -----          | -----          | -----       | -----        | 1.00           |
| * 47338.52       | -----          | -----     | -----      | -----  | 9.50      | 0.00        | -----          | -----          | -----       | -----        | 1.00           |
| * 52598.35       | -----          | -----     | -----      | -----  | 9.50      | 0.00        | -----          | -----          | -----       | -----        | 1.00           |

Note :

- The measurement was searched to 10th harmonic, Remark “---” means that the emissions level is too low to be measured.
- AF: Antenna Factor, Cable: Cable Loss, Pre-Amp: Preamplifier gain, Filter: High Pass Filter Insertion Loss (8.2GHz)
- Spectrum analyzer setting P(Peak): RBW=1MHz, VBW=1MHz, A(Average): RBW=1MHz, VBW=10Hz
- Remark “\*” means the Restricted band.
- Dist : correction to extra plate reading to 3m specification distance 1m measurement distance = -9.5dB
- The result basic equation calculation is as follow:  
 Level = Reading + AF + Cable - Preamp + Filter - Dist, Margin = Level - Limit
- The test limit distance is 3M limit.
- For normal 802.11a mode.



**Ecom Sertech Corp.**

Rm. 258, Bldg. 17, NO.195, Sec.4 Chung Hsing Rd., ChuTugn Chen, Hsinchu, Taiwan 310, R.O.C  
 TEL: 886-3-5918012 FAX: 886-3-5825720

FCC ID : PY3WG111U

Report No. : ER04-11-043FRFa

Page 26 of 84

The frequency spectrum above 1 GHz for Transmitter was investigated. All emissions not reported are much lower than the prescribed limits. Readings are both peak and average values.

|                     |   |                            |             |
|---------------------|---|----------------------------|-------------|
| <b>Company</b>      | Netgear Incorporated                            | <b>Test Date</b>           | 2004/11/24  |
| <b>Product Name</b> | Double 108 Mbps Wireless USB 2.0 Adapter WG111U | <b>Test By</b>             | Alan Fan    |
| <b>Model Name</b>   | WG111U  | <b>TEMP &amp; Humidity</b> | 30.4°C, 54% |

| CH8 (5320MHz) TX |                |           |            | Measurement Distance at 1m Horizontal polarity |           |             |                |                       |             |              |                |
|------------------|----------------|-----------|------------|--|-----------|-------------|----------------|-----------------------|-------------|--------------|----------------|
| Freq. (MHz)      | Reading (dBμV) | AF (dBμV) | Cable (dB) | Pre-amp (dB)                                   | Dist (dB) | Filter (dB) | Level (dBμV/m) | Limit (dBμV/m)        | Margin (dB) | Mark (P/Q/A) | Height (Meter) |
| 3546.61          | 50.95          | 31.51     | 4.38       | 35.35  | 9.50      | 0.00        | 41.98          | 88.30                 | -46.32      | P            | 1.21           |
| 3546.61          | 45.87          | 31.51     | 4.38       | 35.35  | 9.50      | 0.00        | 36.90          | 68.30                 | -31.40      | A            | 1.21           |
| 5320.00          | 66.18          | 36.05     | 5.54       | 0.00   | 9.50      | 0.00        | 98.27          | Fundamental Frequency |             | P            | 1.11           |
| 5320.00          | 56.78          | 36.05     | 5.54       | 0.00   | 9.50      | 0.00        | 88.87          |                       |             | A            | 1.11           |
| * 5351.87        | 27.61          | 36.09     | 5.58       | 0.00   | 9.50      | 0.00        | 59.79          | 74.00                 | -14.21      | P            | 1.11           |
| * 5351.87        | 15.41          | 36.09     | 5.58       | 0.00   | 9.50      | 0.00        | 47.59          | 54.00                 | -6.41       | A            | 1.11           |
| 7093.04          | 50.42          | 39.86     | 6.64       | 35.68  | 9.50      | 0.00        | 51.74          | 88.30                 | -36.56      | P            | 1.08           |
| 7093.04          | 45.93          | 39.86     | 6.64       | 35.68  | 9.50      | 0.00        | 47.25          | 68.30                 | -21.05      | A            | 1.08           |
| * 10635.45       | 48.53          | 39.26     | 8.61       | 35.90  | 9.50      | 0.79        | 51.79          | 74.00                 | -22.21      | P            | 1.02           |
| * 10635.45       | 37.96          | 39.26     | 8.61       | 35.90  | 9.50      | 0.79        | 41.22          | 54.00                 | -12.78      | A            | 1.02           |
| * 15954.36       | 50.16          | 43.66     | 8.98       | 36.38  | 9.50      | 0.30        | 57.22          | 74.00                 | -16.78      | P            | 1.00           |
| * 15954.36       | 39.39          | 43.66     | 8.98       | 36.38  | 9.50      | 0.30        | 46.45          | 54.00                 | -7.55       | A            | 1.00           |
| * 21280.00       | -----          | -----     | -----      | -----  | 9.50      | 3.12        | -----          | -----                 | -----       | -----        | 1.00           |
| 26600.00         | -----          | -----     | -----      | -----  | 9.50      | 2.14        | -----          | -----                 | -----       | -----        | 1.00           |
| 31920.00         | -----          | -----     | -----      | -----  | 9.50      | 0.00        | -----          | -----                 | -----       | -----        | 1.00           |
| 37240.00         | -----          | -----     | -----      | -----  | 9.50      | 0.00        | -----          | -----                 | -----       | -----        | 1.00           |
| * 42560.00       | -----          | -----     | -----      | -----  | 9.50      | 0.00        | -----          | -----                 | -----       | -----        | 1.00           |
| * 47880.00       | -----          | -----     | -----      | -----  | 9.50      | 0.00        | -----          | -----                 | -----       | -----        | 1.00           |
| * 53200.00       | -----          | -----     | -----      | -----  | 9.50      | 0.00        | -----          | -----                 | -----       | -----        | 1.00           |

Note :

- The measurement was searched to 10th harmonic, Remark “---” means that the emissions level is too low to be measured.
- AF: Antenna Factor, Cable: Cable Loss, Pre-Amp: Preamplifier gain, Filter: High Pass Filter Insertion Loss (8.2GHz)
- Spectrum analyzer setting P(Peak): RBW=1MHz, VBW=1MHz, A(Average): RBW=1MHz, VBW=10Hz
- Remark “\*” means the Restricted band.
- Dist : correction to extra plate reading to 3m specification distance 1m measurement distance = -9.5dB
- The result basic equation calculation is as follow:  
 $Level = Reading + AF + Cable - Preamp + Filter - Dist$ ,  $Margin = Level - Limit$
- The test limit distance is 3M limit.
- For normal 802.11a mode.



**Ecom Sertech Corp.**

Rm. 258, Bldg. 17, NO.195, Sec.4 Chung Hsing Rd., ChuTugn Chen, Hsinchu, Taiwan 310, R.O.C  
 TEL: 886-3-5918012 FAX: 886-3-5825720

FCC ID : PY3WG111U

Report No. : ER04-11-043FRFa

Page 27 of 84

The frequency spectrum above 1 GHz for Transmitter was investigated. All emissions not reported are much lower than the prescribed limits. Readings are both peak and average values.

|                     |   |                            |             |
|---------------------|---|----------------------------|-------------|
| <b>Company</b>      | Netgear Incorporated                            | <b>Test Date</b>           | 2004/11/24  |
| <b>Product Name</b> | Double 108 Mbps Wireless USB 2.0 Adapter WG111U | <b>Test By</b>             | Alan Fan    |
| <b>Model Name</b>   | WG111U  | <b>TEMP &amp; Humidity</b> | 30.4°C, 54% |

| CH8 (5320MHz) TX |                |           |            | Measurement Distance at 1m Vertical polarity |           |             |                |                       |             |              |                |
|------------------|----------------|-----------|------------|--|-----------|-------------|----------------|-----------------------|-------------|--------------|----------------|
| Freq. (MHz)      | Reading (dBμV) | AF (dBμV) | Cable (dB) | Pre-amp (dB)                                 | Dist (dB) | Filter (dB) | Level (dBμV/m) | Limit (dBμV/m)        | Margin (dB) | Mark (P/Q/A) | Height (Meter) |
| 3546.47          | 50.15          | 31.51     | 4.38       | 35.35  | 9.50      | 0.00        | 41.18          | 88.30                 | -47.12      | P            | 1.09           |
| 3546.47          | 45.46          | 31.51     | 4.38       | 35.35  | 9.50      | 0.00        | 36.49          | 68.30                 | -31.81      | A            | 1.09           |
| 5315.89          | 66.76          | 36.04     | 5.54       | 0.00   | 9.50      | 0.00        | 98.84          | Fundamental Frequency |             | P            | 1.10           |
| 5315.89          | 57.60          | 36.04     | 5.54       | 0.00   | 9.50      | 0.00        | 89.68          |                       |             | A            | 1.10           |
| * 5351.87        | 28.22          | 36.09     | 5.58       | 0.00   | 9.50      | 0.00        | 60.40          | 74.00                 | -13.60      | P            | 1.10           |
| * 5351.87        | 15.41          | 36.09     | 5.58       | 0.00   | 9.50      | 0.00        | 47.59          | 54.00                 | -6.41       | A            | 1.10           |
| 7093.19          | 49.00          | 39.86     | 6.64       | 35.68  | 9.50      | 0.00        | 50.32          | 88.30                 | -37.98      | P            | 1.12           |
| 7093.19          | 43.23          | 39.86     | 6.64       | 35.68  | 9.50      | 0.00        | 44.55          | 68.30                 | -23.75      | A            | 1.12           |
| * 10640.55       | 48.98          | 39.27     | 8.61       | 35.90  | 9.50      | 0.80        | 52.26          | 74.00                 | -21.74      | P            | 1.00           |
| * 10640.55       | 37.42          | 39.27     | 8.61       | 35.90  | 9.50      | 0.80        | 40.70          | 54.00                 | -13.30      | A            | 1.00           |
| * 15960.02       | 50.65          | 43.64     | 8.99       | 36.39  | 9.50      | 0.30        | 57.69          | 74.00                 | -16.31      | P            | 1.00           |
| * 15960.02       | 39.90          | 43.64     | 8.99       | 36.39  | 9.50      | 0.30        | 46.94          | 54.00                 | -7.06       | A            | 1.00           |
| * 21263.56       | -----          | -----     | -----      | -----  | 9.50      | 3.29        | -----          | -----                 | -----       | -----        | 1.00           |
| 26579.45         | -----          | -----     | -----      | -----  | 9.50      | 2.13        | -----          | -----                 | -----       | -----        | 1.00           |
| 31895.34         | -----          | -----     | -----      | -----  | 9.50      | 0.00        | -----          | -----                 | -----       | -----        | 1.00           |
| 37211.23         | -----          | -----     | -----      | -----  | 9.50      | 0.00        | -----          | -----                 | -----       | -----        | 1.00           |
| * 42527.12       | -----          | -----     | -----      | -----  | 9.50      | 0.00        | -----          | -----                 | -----       | -----        | 1.00           |
| * 47843.01       | -----          | -----     | -----      | -----  | 9.50      | 0.00        | -----          | -----                 | -----       | -----        | 1.00           |
| * 53158.90       | -----          | -----     | -----      | -----  | 9.50      | 0.00        | -----          | -----                 | -----       | -----        | 1.00           |

Note :

- The measurement was searched to 10th harmonic, Remark “---” means that the emissions level is too low to be measured.
- AF: Antenna Factor, Cable: Cable Loss, Pre-Amp: Preamplifier gain, Filter: High Pass Filter Insertion Loss (8.2GHz)
- Spectrum analyzer setting P(Peak): RBW=1MHz, VBW=1MHz, A(Average): RBW=1MHz, VBW=10Hz
- Remark “\*” means the Restricted band.
- Dist : correction to extra plate reading to 3m specification distance 1m measurement distance = -9.5dB
- The result basic equation calculation is as follow:  
 Level = Reading + AF + Cable - Preamp + Filter - Dist, Margin = Level - Limit
- The test limit distance is 3M limit.
- For normal 802.11a mode.



**Ecom Sertech Corp.**

Rm. 258, Bldg. 17, NO.195, Sec.4 Chung Hsing Rd., ChuTugn Chen, Hsinchu, Taiwan 310, R.O.C  
 TEL: 886-3-5918012 FAX: 886-3-5825720

FCC ID : PY3WG111U

Report No. : ER04-11-043FRFa

Page 28 of 84

The frequency spectrum above 1 GHz for Transmitter was investigated. All emissions not reported are much lower than the prescribed limits. Readings are both peak and average values.

|                     |   |                            |             |
|---------------------|---|----------------------------|-------------|
| <b>Company</b>      | Netgear Incorporated                            | <b>Test Date</b>           | 2004/12/12  |
| <b>Product Name</b> | Double 108 Mbps Wireless USB 2.0 Adapter WG111U | <b>Test By</b>             | Alan Fan    |
| <b>Model Name</b>   | WG111U  | <b>TEMP &amp; Humidity</b> | 21.1°C, 83% |

| Low (5210MHz) TX |                |           |            | Measurement Distance at 1m Horizontal polarity |           |             |                |                       |             |              |                |
|------------------|----------------|-----------|------------|--|-----------|-------------|----------------|-----------------------|-------------|--------------|----------------|
| Freq. (MHz)      | Reading (dBμV) | AF (dBμV) | Cable (dB) | Pre-amp (dB)                                   | Dist (dB) | Filter (dB) | Level (dBμV/m) | Limit (dBμV/m)        | Margin (dB) | Mark (P/Q/A) | Height (Meter) |
| 3473.28          | 47.15          | 31.42     | 4.30       | 35.43  | 9.50      | 0.00        | 37.94          | 88.30                 | -50.36      | P            | 1.28           |
| 3473.28          | 41.31          | 31.42     | 4.30       | 35.43  | 9.50      | 0.00        | 32.10          | 68.30                 | -36.20      | A            | 1.28           |
| * 5149.72        | 26.61          | 35.81     | 5.33       | 0.00   | 9.50      | 0.00        | 58.25          | 74.00                 | -15.75      | P            | 1.05           |
| * 5149.72        | 15.41          | 35.81     | 5.33       | 0.00   | 9.50      | 0.00        | 47.05          | 54.00                 | -6.95       | A            | 1.05           |
| 5207.85          | 67.83          | 35.89     | 5.40       | 0.00   | 9.50      | 0.00        | 99.62          | Fundamental Frequency |             | P            | 1.00           |
| 5207.85          | 58.95          | 35.89     | 5.40       | 0.00   | 9.50      | 0.00        | 90.74          |                       |             | A            | 1.00           |
| 6946.69          | 45.72          | 39.71     | 6.57       | 35.55  | 9.50      | 2.02        | 48.97          | 88.30                 | -39.33      | P            | 1.13           |
| 6946.69          | 38.71          | 39.71     | 6.57       | 35.55  | 9.50      | 2.02        | 41.96          | 68.30                 | -26.34      | A            | 1.13           |
| 10416.69         | 64.31          | 39.00     | 8.55       | 36.08  | 9.50      | 0.57        | 66.84          | 88.30                 | -21.46      | P            | 1.02           |
| 10416.69         | 52.61          | 39.00     | 8.55       | 36.08  | 9.50      | 0.57        | 55.14          | 68.30                 | -13.16      | A            | 1.02           |
| * 15629.97       | 45.21          | 44.83     | 8.78       | 35.89  | 9.50      | 0.30        | 53.73          | 74.00                 | -20.27      | P            | 1.00           |
| * 15629.97       | 34.02          | 44.83     | 8.78       | 35.89  | 9.50      | 0.30        | 42.54          | 54.00                 | -11.46      | A            | 1.00           |
| * 20831.40       | -----          | -----     | -----      | -----  | 9.50      | 5.40        | -----          | -----                 | -----       | -----        | 1.00           |
| 26039.25         | -----          | -----     | -----      | -----  | 9.50      | 1.64        | -----          | -----                 | -----       | -----        | 1.00           |
| * 31247.10       | -----          | -----     | -----      | -----  | 9.50      | 0.00        | -----          | -----                 | -----       | -----        | 1.00           |
| * 36454.95       | -----          | -----     | -----      | -----  | 9.50      | 0.00        | -----          | -----                 | -----       | -----        | 1.00           |
| * 41662.80       | -----          | -----     | -----      | -----  | 9.50      | 0.00        | -----          | -----                 | -----       | -----        | 1.00           |
| * 46870.65       | -----          | -----     | -----      | -----  | 9.50      | 0.00        | -----          | -----                 | -----       | -----        | 1.00           |
| * 52078.50       | -----          | -----     | -----      | -----  | 9.50      | 0.00        | -----          | -----                 | -----       | -----        | 1.00           |

Note :

- The measurement was searched to 10th harmonic, Remark “----” means that the emissions level is too low to be measured.
- AF: Antenna Factor, Cable: Cable Loss, Pre-Amp: Preamplifier gain, Filter: High Pass Filter Insertion Loss (8.2GHz)
- Spectrum analyzer setting P(Peak): RBW=1MHz, VBW=1MHz, A(Average): RBW=1MHz, VBW=10Hz
- Remark “\*” means the Restricted band.
- Dist : correction to extra plate reading to 3m specification distance 1m measurement distance = -9.5dB
- The result basic equation calculation is as follow:  
 Level = Reading + AF + Cable - Preamp + Filter - Dist, Margin = Level - Limit
- The test limit distance is 3M limit.
- For Super A mode.



**Ecom Sertech Corp.**

Rm. 258, Bldg. 17, NO.195, Sec.4 Chung Hsing Rd., ChuTugn Chen, Hsinchu, Taiwan 310, R.O.C  
 TEL: 886-3-5918012 FAX: 886-3-5825720

FCC ID : PY3WG111U

Report No. : ER04-11-043FRFa

Page 29 of 84

The frequency spectrum above 1 GHz for Transmitter was investigated. All emissions not reported are much lower than the prescribed limits. Readings are both peak and average values.

|                     |   |                            |             |
|---------------------|---|----------------------------|-------------|
| <b>Company</b>      | Netgear Incorporated                            | <b>Test Date</b>           | 2004/12/12  |
| <b>Product Name</b> | Double 108 Mbps Wireless USB 2.0 Adapter WG111U | <b>Test By</b>             | Alan Fan    |
| <b>Model Name</b>   | WG111U  | <b>TEMP &amp; Humidity</b> | 21.1°C, 83% |

| Low (5210MHz) TX |                |           |            | Measurement Distance at 1m Vertical polarity |           |             |                |                       |             |              |                |
|------------------|----------------|-----------|------------|--|-----------|-------------|----------------|-----------------------|-------------|--------------|----------------|
| Freq. (MHz)      | Reading (dBμV) | AF (dBμV) | Cable (dB) | Pre-amp (dB)                                 | Dist (dB) | Filter (dB) | Level (dBμV/m) | Limit (dBμV/m)        | Margin (dB) | Mark (P/Q/A) | Height (Meter) |
| 3473.25          | 50.37          | 31.42     | 4.30       | 35.43  | 9.50      | 0.00        | 41.16          | 88.30                 | -47.14      | P            | 1.00           |
| 3473.25          | 46.71          | 31.42     | 4.30       | 35.43  | 9.50      | 0.00        | 37.50          | 68.30                 | -30.80      | A            | 1.00           |
| * 5149.72        | 27.82          | 35.81     | 5.33       | 0.00   | 9.50      | 0.00        | 59.46          | 74.00                 | -14.54      | P            | 1.13           |
| * 5149.72        | 15.41          | 35.81     | 5.33       | 0.00   | 9.50      | 0.00        | 47.05          | 54.00                 | -6.95       | A            | 1.13           |
| 5210.80          | 61.89          | 35.90     | 5.41       | 0.00   | 9.50      | 0.00        | 93.69          | Fundamental Frequency |             | P            | 1.00           |
| 5210.80          | 53.32          | 35.90     | 5.41       | 0.00   | 9.50      | 0.00        | 85.12          |                       |             | A            | 1.00           |
| 6946.59          | 46.72          | 39.71     | 6.57       | 35.55  | 9.50      | 0.00        | 47.95          | 88.30                 | -40.35      | P            | 1.00           |
| 6946.59          | 40.34          | 39.71     | 6.57       | 35.55  | 9.50      | 0.00        | 41.57          | 68.30                 | -26.73      | A            | 1.00           |
| 10416.59         | 61.04          | 39.00     | 8.54       | 36.08  | 9.50      | 0.57        | 63.57          | 88.30                 | -24.73      | P            | 1.09           |
| 10416.59         | 49.74          | 39.00     | 8.54       | 36.08  | 9.50      | 0.57        | 52.27          | 68.30                 | -16.03      | A            | 1.09           |
| * 15629.98       | 45.03          | 44.83     | 8.78       | 35.89  | 9.50      | 0.30        | 53.55          | 74.00                 | -20.45      | P            | 1.00           |
| * 15629.98       | 32.88          | 44.83     | 8.78       | 35.89  | 9.50      | 0.30        | 41.40          | 54.00                 | -12.60      | A            | 1.00           |
| * 20843.20       | -----          | -----     | -----      | -----  | 9.50      | 5.44        | -----          | -----                 | -----       | -----        | 1.00           |
| 26054.00         | -----          | -----     | -----      | -----  | 9.50      | 1.65        | -----          | -----                 | -----       | -----        | 1.00           |
| * 31264.80       | -----          | -----     | -----      | -----  | 9.50      | 0.00        | -----          | -----                 | -----       | -----        | 1.00           |
| * 36475.60       | -----          | -----     | -----      | -----  | 9.50      | 0.00        | -----          | -----                 | -----       | -----        | 1.00           |
| * 41686.40       | -----          | -----     | -----      | -----  | 9.50      | 0.00        | -----          | -----                 | -----       | -----        | 1.00           |
| * 46897.20       | -----          | -----     | -----      | -----  | 9.50      | 0.00        | -----          | -----                 | -----       | -----        | 1.00           |
| * 52108.00       | -----          | -----     | -----      | -----  | 9.50      | 0.00        | -----          | -----                 | -----       | -----        | 1.00           |

- Note :
- The measurement was searched to 10th harmonic, Remark “---” means that the emissions level is too low to be measured.
  - AF: Antenna Factor, Cable: Cable Loss, Pre-Amp: Preamplifier gain, Filter: High Pass Filter Insertion Loss (8.2GHz)
  - Spectrum analyzer setting P(Peak): RBW=1MHz, VBW=1MHz, A(Average): RBW=1MHz, VBW=10Hz
  - Remark “\*” means the Restricted band.
  - Dist : correction to extra plate reading to 3m specification distance 1m measurement distance = -9.5dB
  - The result basic equation calculation is as follow:  
 $Level = Reading + AF + Cable - Preamp + Filter - Dist$ ,  $Margin = Level - Limit$
  - The test limit distance is 3M limit.
  - For Super A mode.



**Ecom Sertech Corp.**

Rm. 258, Bldg. 17, NO.195, Sec.4 Chung Hsing Rd., ChuTugn Chen, Hsinchu, Taiwan 310, R.O.C  
 TEL: 886-3-5918012 FAX: 886-3-5825720

FCC ID : PY3WG111U

Report No. : ER04-11-043FRFa

Page 30 of 84

The frequency spectrum above 1 GHz for Transmitter was investigated. All emissions not reported are much lower than the prescribed limits. Readings are both peak and average values.

|                     |   |                            |             |
|---------------------|---|----------------------------|-------------|
| <b>Company</b>      | Netgear Incorporated                            | <b>Test Date</b>           | 2004/12/12  |
| <b>Product Name</b> | Double 108 Mbps Wireless USB 2.0 Adapter WG111U | <b>Test By</b>             | Alan Fan    |
| <b>Model Name</b>   | WG111U  | <b>TEMP &amp; Humidity</b> | 21.1°C, 83% |

| Middle (5250MHz) TX |                |           |            | Measurement Distance at 1m Horizontal polarity |           |             |                |                |             |              |                |
|---------------------|----------------|-----------|------------|--|-----------|-------------|----------------|----------------|-------------|--------------|----------------|
| Freq. (MHz)         | Reading (dBμV) | AF (dBμV) | Cable (dB) | Pre-amp (dB)                                   | Dist (dB) | Filter (dB) | Level (dBμV/m) | Limit (dBμV/m) | Margin (dB) | Mark (P/Q/A) | Height (Meter) |
| 3499.95             | 48.98          | 31.40     | 4.33       | 35.40  | 9.50      | 0.00        | 39.81          | 88.30          | -48.49      | P            | 1.25           |
| 3499.95             | 42.85          | 31.40     | 4.33       | 35.40  | 9.50      | 0.00        | 33.68          | 68.30          | -34.62      | A            | 1.25           |
| 6999.81             | 47.26          | 39.90     | 6.58       | 35.70  | 9.50      | 0.00        | 48.54          | 88.30          | -39.76      | P            | 1.08           |
| 6999.81             | 40.92          | 39.90     | 6.58       | 35.70  | 9.50      | 0.00        | 42.20          | 68.30          | -26.10      | A            | 1.08           |
| 10497.50            | 61.06          | 39.10     | 8.57       | 35.91  | 9.50      | 0.60        | 63.92          | 88.30          | -24.38      | P            | 1.03           |
| 10497.50            | 50.63          | 39.10     | 8.57       | 35.91  | 9.50      | 0.60        | 53.49          | 68.30          | -14.81      | A            | 1.03           |
| * 15749.49          | 44.39          | 44.40     | 8.85       | 36.07  | 9.50      | 0.30        | 52.37          | 74.00          | -21.63      | P            | 1.00           |
| * 15749.49          | 33.84          | 44.40     | 8.85       | 36.07  | 9.50      | 0.30        | 41.82          | 54.00          | -12.18      | A            | 1.00           |
| * 20995.00          | -----          | -----     | -----      | -----  | 9.50      | 5.93        | -----          | -----          | -----       | -----        | 1.00           |
| 26243.75            | -----          | -----     | -----      | -----  | 9.50      | 1.84        | -----          | -----          | -----       | -----        | 1.00           |
| * 31492.50          | -----          | -----     | -----      | -----  | 9.50      | 0.00        | -----          | -----          | -----       | -----        | 1.00           |
| 36741.25            | -----          | -----     | -----      | -----  | 9.50      | 0.00        | -----          | -----          | -----       | -----        | 1.00           |
| * 41990.00          | -----          | -----     | -----      | -----  | 9.50      | 0.00        | -----          | -----          | -----       | -----        | 1.00           |
| * 47238.75          | -----          | -----     | -----      | -----  | 9.50      | 0.00        | -----          | -----          | -----       | -----        | 1.00           |
| * 52487.50          | -----          | -----     | -----      | -----  | 9.50      | 0.00        | -----          | -----          | -----       | -----        | 1.00           |

Note :

- The measurement was searched to 10th harmonic, Remark “---” means that the emissions level is too low to be measured.
- AF: Antenna Factor, Cable: Cable Loss, Pre-Amp: Preamplifier gain, Filter: High Pass Filter Insertion Loss (8.2GHz)
- Spectrum analyzer setting P(Peak): RBW=1MHz, VBW=1MHz, A(Average): RBW=1MHz, VBW=10Hz
- Remark “\*” means the Restricted band.
- Dist : correction to extra plate reading to 3m specification distance 1m measurement distance = -9.5dB
- The result basic equation calculation is as follow:  
 Level = Reading + AF + Cable - Preamp + Filter - Dist, Margin = Level - Limit
- The test limit distance is 3M limit.
- For Super A mode.



**Ecom Sertech Corp.**

Rm. 258, Bldg. 17, NO.195, Sec.4 Chung Hsing Rd., ChuTugn Chen, Hsinchu, Taiwan 310, R.O.C  
 TEL: 886-3-5918012 FAX: 886-3-5825720

FCC ID : PY3WG111U

Report No. : ER04-11-043FRFa

Page  31  of  84

The frequency spectrum above 1 GHz for Transmitter was investigated. All emissions not reported are much lower than the prescribed limits. Readings are both peak and average values.

|                     |   |                            |             |
|---------------------|---|----------------------------|-------------|
| <b>Company</b>      | Netgear Incorporated                            | <b>Test Date</b>           | 2004/12/12  |
| <b>Product Name</b> | Double 108 Mbps Wireless USB 2.0 Adapter WG111U | <b>Test By</b>             | Alan Fan    |
| <b>Model Name</b>   | WG111U  | <b>TEMP &amp; Humidity</b> | 21.1°C, 83% |

| Middle (5250MHz) TX |                |           |            | Measurement Distance at 1m Vertical polarity |           |             |                |                |             |              |                |
|---------------------|----------------|-----------|------------|--|-----------|-------------|----------------|----------------|-------------|--------------|----------------|
| Freq. (MHz)         | Reading (dBμV) | AF (dBμV) | Cable (dB) | Pre-amp (dB)                                 | Dist (dB) | Filter (dB) | Level (dBμV/m) | Limit (dBμV/m) | Margin (dB) | Mark (P/Q/A) | Height (Meter) |
| 3499.97             | 50.84          | 31.40     | 4.33       | 35.40  | 9.50      | 0.00        | 41.67          | 88.30          | -46.63      | P            | 1.10           |
| 3499.97             | 46.12          | 31.40     | 4.33       | 35.40  | 9.50      | 0.00        | 36.95          | 68.30          | -31.35      | A            | 1.10           |
| 6999.95             | 47.12          | 39.90     | 6.58       | 35.70  | 9.50      | 0.00        | 48.40          | 88.30          | -39.90      | P            | 1.12           |
| 6999.95             | 40.88          | 39.90     | 6.58       | 35.70  | 9.50      | 0.00        | 42.16          | 68.30          | -26.14      | A            | 1.12           |
| 10495.89            | 56.87          | 39.10     | 8.57       | 35.91  | 9.50      | 0.60        | 59.72          | 88.30          | -28.58      | P            | 1.00           |
| 10495.89            | 46.26          | 39.10     | 8.57       | 35.91  | 9.50      | 0.60        | 49.11          | 68.30          | -19.19      | A            | 1.00           |
| * 15750.01          | 45.25          | 44.40     | 8.86       | 36.08  | 9.50      | 0.30        | 53.23          | 74.00          | -20.77      | P            | 1.00           |
| * 15750.01          | 32.58          | 44.40     | 8.86       | 36.08  | 9.50      | 0.30        | 40.56          | 54.00          | -13.44      | A            | 1.00           |
| * 20991.78          | -----          | -----     | -----      | -----  | 0.00      | 5.92        | -----          | -----          | -----       | -----        | 1.00           |
| 26239.73            | -----          | -----     | -----      | -----  | 0.00      | 1.84        | -----          | -----          | -----       | -----        | 1.00           |
| * 31487.67          | -----          | -----     | -----      | -----  | 0.00      | 0.00        | -----          | -----          | -----       | -----        | 1.00           |
| 36735.62            | -----          | -----     | -----      | -----  | 0.00      | 0.00        | -----          | -----          | -----       | -----        | 1.00           |
| * 41983.56          | -----          | -----     | -----      | -----  | 0.00      | 0.00        | -----          | -----          | -----       | -----        | 1.00           |
| * 47231.51          | -----          | -----     | -----      | -----  | 0.00      | 0.00        | -----          | -----          | -----       | -----        | 1.00           |
| * 52479.45          | -----          | -----     | -----      | -----  | 0.00      | 0.00        | -----          | -----          | -----       | -----        | 1.00           |

Note :

- The measurement was searched to 10th harmonic, Remark “---” means that the emissions level is too low to be measured.
- AF: Antenna Factor, Cable: Cable Loss, Pre-Amp: Preamplifier gain, Filter: High Pass Filter Insertion Loss (8.2GHz)
- Spectrum analyzer setting P(Peak): RBW=1MHz, VBW=1MHz, A(Average): RBW=1MHz, VBW=10Hz
- Remark “\*” means the Restricted band.
- Dist : correction to extra plate reading to 3m specification distance 1m measurement distance = -9.5dB
- The result basic equation calculation is as follow:  
 Level = Reading + AF + Cable - Preamp + Filter - Dist, Margin = Level - Limit
- The test limit distance is 3M limit.
- For Super A mode.



**Ecom Sertech Corp.**

Rm. 258, Bldg. 17, NO.195, Sec.4 Chung Hsing Rd., ChuTugn Chen, Hsinchu, Taiwan 310, R.O.C  
 TEL: 886-3-5918012 FAX: 886-3-5825720

FCC ID : PY3WG111U

Report No. : ER04-11-043FRFa

Page 32 of 84

The frequency spectrum above 1 GHz for Transmitter was investigated. All emissions not reported are much lower than the prescribed limits. Readings are both peak and average values.

|                     |   |                            |             |
|---------------------|---|----------------------------|-------------|
| <b>Company</b>      | Netgear Incorporated                            | <b>Test Date</b>           | 2004/12/12  |
| <b>Product Name</b> | Double 108 Mbps Wireless USB 2.0 Adapter WG111U | <b>Test By</b>             | Alan Fan    |
| <b>Model Name</b>   | WG111U  | <b>TEMP &amp; Humidity</b> | 21.1°C, 83% |

| High (5290MHz) TX |                |           |            | Measurement Distance at 1m Horizontal polarity |           |             |                |                       |             |              |                |
|-------------------|----------------|-----------|------------|--|-----------|-------------|----------------|-----------------------|-------------|--------------|----------------|
| Freq. (MHz)       | Reading (dBμV) | AF (dBμV) | Cable (dB) | Pre-amp (dB)                                   | Dist (dB) | Filter (dB) | Level (dBμV/m) | Limit (dBμV/m)        | Margin (dB) | Mark (P/Q/A) | Height (Meter) |
| 3526.57           | 48.63          | 31.46     | 4.36       | 35.37  | 9.50      | 0.00        | 39.58          | 88.30                 | -48.72      | P            | 1.22           |
| 3526.57           | 43.00          | 31.46     | 4.36       | 35.37  | 9.50      | 0.00        | 33.95          | 68.30                 | -34.35      | A            | 1.22           |
| 5291.60           | 72.81          | 36.01     | 5.51       | 0.00   | 9.50      | 0.00        | 104.83         | Fundamental Frequency |             | P            | 1.11           |
| 5291.60           | 63.39          | 36.01     | 5.51       | 0.00   | 9.50      | 0.00        | 95.41          |                       |             | A            | 1.11           |
| * 5351.87         | 27.90          | 36.09     | 5.58       | 0.00   | 9.50      | 0.00        | 60.08          | 74.00                 | -13.92      | P            | 1.11           |
| * 5351.87         | 15.41          | 36.09     | 5.58       | 0.00   | 9.50      | 0.00        | 47.59          | 54.00                 | -6.41       | A            | 1.11           |
| 7053.17           | 47.63          | 39.88     | 6.62       | 35.69  | 9.50      | 0.00        | 48.94          | 88.30                 | -39.36      | P            | 1.04           |
| 7053.17           | 41.00          | 39.88     | 6.62       | 35.69  | 9.50      | 0.00        | 42.31          | 68.30                 | -25.99      | A            | 1.04           |
| 10582.10          | 60.27          | 39.20     | 8.59       | 35.90  | 9.50      | 0.71        | 63.38          | 88.30                 | -24.92      | P            | 1.02           |
| 10582.10          | 48.05          | 39.20     | 8.59       | 35.90  | 9.50      | 0.71        | 51.16          | 68.30                 | -17.14      | A            | 1.02           |
| * 15869.97        | 44.96          | 43.97     | 8.93       | 36.25  | 9.50      | 0.30        | 52.40          | 74.00                 | -21.60      | P            | 1.00           |
| * 15869.97        | 33.27          | 43.97     | 8.93       | 36.25  | 9.50      | 0.30        | 40.71          | 54.00                 | -13.29      | A            | 1.00           |
| * 21166.40        | -----          | -----     | -----      | -----  | 9.50      | 4.27        | -----          | -----                 | -----       | -----        | 1.00           |
| 26458.00          | -----          | -----     | -----      | -----  | 9.50      | 2.06        | -----          | -----                 | -----       | -----        | 1.00           |
| * 31749.60        | -----          | -----     | -----      | -----  | 9.50      | 0.00        | -----          | -----                 | -----       | -----        | 1.00           |
| 37041.20          | -----          | -----     | -----      | -----  | 9.50      | 0.00        | -----          | -----                 | -----       | -----        | 1.00           |
| * 42332.80        | -----          | -----     | -----      | -----  | 9.50      | 0.00        | -----          | -----                 | -----       | -----        | 1.00           |
| * 47624.40        | -----          | -----     | -----      | -----  | 9.50      | 0.00        | -----          | -----                 | -----       | -----        | 1.00           |
| * 52916.00        | -----          | -----     | -----      | -----  | 9.50      | 0.00        | -----          | -----                 | -----       | -----        | 1.00           |

Note :

- The measurement was searched to 10th harmonic, Remark “---” means that the emissions level is too low to be measured.
- AF: Antenna Factor, Cable: Cable Loss, Pre-Amp: Preamplifier gain, Filter: High Pass Filter Insertion Loss (8.2GHz)
- Spectrum analyzer setting P(Peak): RBW=1MHz, VBW=1MHz, A(Average): RBW=1MHz, VBW=10Hz
- Remark “\*” means the Restricted band.
- Dist : correction to extra plate reading to 3m specification distance 1m measurement distance = -9.5dB
- The result basic equation calculation is as follow:  
 Level = Reading + AF + Cable - Preamp + Filter - Dist, Margin = Level - Limit
- The test limit distance is 3M limit.
- For Super A mode.





**Ecom Sertech Corp.**

Rm. 258, Bldg. 17, NO.195, Sec.4 Chung Hsing Rd., ChuTugn Chen, Hsinchu, Taiwan 310, R.O.C  
 TEL: 886-3-5918012 FAX: 886-3-5825720

FCC ID : PY3WG111U

Report No. : ER04-11-043FRFa

Page 33 of 84

The frequency spectrum above 1 GHz for Transmitter was investigated. All emissions not reported are much lower than the prescribed limits. Readings are both peak and average values.

|                     |   |                            |             |
|---------------------|---|----------------------------|-------------|
| <b>Company</b>      | Netgear Incorporated                            | <b>Test Date</b>           | 2004/12/12  |
| <b>Product Name</b> | Double 108 Mbps Wireless USB 2.0 Adapter WG111U | <b>Test By</b>             | Alan Fan    |
| <b>Model Name</b>   | WG111U  | <b>TEMP &amp; Humidity</b> | 21.1°C, 83% |

| High (5290MHz) TX |                |           |            | Measurement Distance at 1m Vertical polarity |           |             |                |                       |             |              |                |
|-------------------|----------------|-----------|------------|--|-----------|-------------|----------------|-----------------------|-------------|--------------|----------------|
| Freq. (MHz)       | Reading (dBμV) | AF (dBμV) | Cable (dB) | Pre-amp (dB)                                 | Dist (dB) | Filter (dB) | Level (dBμV/m) | Limit (dBμV/m)        | Margin (dB) | Mark (P/Q/A) | Height (Meter) |
| 3526.59           | 50.86          | 31.46     | 4.36       | 35.37  | 9.50      | 0.00        | 41.81          | 88.30                 | -46.49      | P            | 1.09           |
| 3526.59           | 46.68          | 31.46     | 4.36       | 35.37  | 9.50      | 0.00        | 37.63          | 68.30                 | -30.67      | A            | 1.09           |
| 5287.19           | 63.00          | 36.00     | 5.50       | 0.00   | 9.50      | 0.00        | 95.00          | Fundamental Frequency |             | P            | 1.10           |
| 5287.19           | 53.52          | 36.00     | 5.50       | 0.00   | 9.50      | 0.00        | 85.52          |                       |             | A            | 1.10           |
| * 5351.87         | 27.57          | 36.09     | 5.58       | 0.00   | 9.50      | 0.00        | 59.75          | 74.00                 | -14.25      | P            | 1.13           |
| * 5351.87         | 15.41          | 36.09     | 5.58       | 0.00   | 9.50      | 0.00        | 47.59          | 54.00                 | -6.41       | A            | 1.13           |
| 7053.13           | 47.62          | 39.88     | 6.62       | 35.69  | 9.50      | 0.00        | 48.93          | 88.30                 | -39.37      | P            | 1.09           |
| 7053.13           | 40.48          | 39.88     | 6.62       | 35.69  | 9.50      | 0.00        | 41.79          | 68.30                 | -26.51      | A            | 1.09           |
| 10581.79          | 54.35          | 39.20     | 8.59       | 35.90  | 9.50      | 0.71        | 57.46          | 88.30                 | -30.84      | P            | 1.04           |
| 10581.79          | 42.59          | 39.20     | 8.59       | 35.90  | 9.50      | 0.71        | 45.70          | 68.30                 | -22.60      | A            | 1.04           |
| * 15869.98        | 45.20          | 43.97     | 8.93       | 36.25  | 9.50      | 0.30        | 52.64          | 74.00                 | -21.36      | P            | 1.00           |
| * 15869.98        | 33.29          | 43.97     | 8.93       | 36.25  | 9.50      | 0.30        | 40.73          | 54.00                 | -13.27      | A            | 1.00           |
| * 21148.76        | -----          | -----     | -----      | -----  | 9.50      | 4.45        | -----          | -----                 | -----       | -----        | 1.00           |
| 26435.95          | -----          | -----     | -----      | -----  | 9.50      | 2.04        | -----          | -----                 | -----       | -----        | 1.00           |
| * 31723.14        | -----          | -----     | -----      | -----  | 9.50      | 0.00        | -----          | -----                 | -----       | -----        | 1.00           |
| 37010.33          | -----          | -----     | -----      | -----  | 9.50      | 0.00        | -----          | -----                 | -----       | -----        | 1.00           |
| * 42297.52        | -----          | -----     | -----      | -----  | 9.50      | 0.00        | -----          | -----                 | -----       | -----        | 1.00           |
| * 47584.71        | -----          | -----     | -----      | -----  | 9.50      | 0.00        | -----          | -----                 | -----       | -----        | 1.00           |
| * 52871.90        | -----          | -----     | -----      | -----  | 9.50      | 0.00        | -----          | -----                 | -----       | -----        | 1.00           |

Note :

- The measurement was searched to 10th harmonic, Remark “---” means that the emissions level is too low to be measured.
- AF: Antenna Factor, Cable: Cable Loss, Pre-Amp: Preamplifier gain, Filter: High Pass Filter Insertion Loss (8.2GHz)
- Spectrum analyzer setting P(Peak): RBW=1MHz, VBW=1MHz, A(Average): RBW=1MHz, VBW=10Hz
- Remark “\*” means the Restricted band.
- Dist : correction to extra plate reading to 3m specification distance 1m measurement distance = -9.5dB
- The result basic equation calculation is as follow:  
 Level = Reading + AF + Cable - Preamp + Filter - Dist, Margin = Level - Limit
- The test limit distance is 3M limit.
- For Super A mode.



### 3.6.3 Radiated Bandedge Emission of 5.15 ~ 5.35GHz Band

The measured radiated band edge emissions are listed below :

|                     |   |                            |             |
|---------------------|---|----------------------------|-------------|
| <b>Company</b>      | Netgear Incorporated                            | <b>Test Date</b>           | 2004/12/13  |
| <b>Product Name</b> | Double 108 Mbps Wireless USB 2.0 Adapter WG111U | <b>Test By</b>             | Alan Fan    |
| <b>Model Name</b>   | WG111U  | <b>TEMP &amp; Humidity</b> | 21.1°C, 63% |

For normal 802.11a mode

| Band edge Frequency (MHz) |    | Measured radiated band edge field strength (dBuV/m) |          | Radiated band edge field strength limit (dBuV/m) |          | Test result |
|---------------------------|----|---|----------|--|----------|-------------|
|                           |    | Horizontal  | Vertical | Horizontal                                       | Vertical |             |
| 5150.00                   | PK | 64.72   | 57.26    | 74.00  | 74.00    | PASS        |
|                           | AV | 42.97   | 35.19    | 54.00  | 54.00    |             |
| 5350.00                   | PK | 47.75   | 48.32    | 74.00  | 74.00    | PASS        |
|                           | AV | 32.92   | 33.73    | 54.00  | 54.00    |             |

For Super A mode

| Band edge Frequency (MHz) |    | Measured radiated band edge field strength (dBuV/m) |          | Radiated band edge field strength limit (dBuV/m) |          | Test result |
|---------------------------|----|---|----------|--|----------|-------------|
|                           |    | Horizontal  | Vertical | Horizontal                                       | Vertical |             |
| 5150.00                   | PK | 55.63   | 49.70    | 74.00  | 74.00    | PASS        |
|                           | AV | 38.75   | 33.13    | 54.00  | 54.00    |             |
| 5350.00                   | PK | 58.60   | 48.77    | 74.00  | 74.00    | PASS        |
|                           | AV | 42.65   | 32.76    | 54.00  | 54.00    |             |

Note :

1. Radiated band edge field strength is measured with FCC recommended mark-delta method.
2. Measured radiated band edge field strength Test Results = Radiated fundamental emission field strength - DELTA.
3. DELTA = Relative measurement between conducted measured peak level of fundamental emission and relevant band edge emission. Please refer to 7.7 photo of Band Edge Measurement.



### 3.6.4 Photo of Bandedge Measurement

In 5.15 ~ 5.35GHz Band  
For normal 802.11a mode  
Carrier Frequency : 5180MHz

Marker 2 [T1] RBW 1 MHz RF Att 30 dB  
Ref Lvl 75.00 dBμV VBW 1 MHz  
127 dBμV 5.15000000 GHz SWT 5 ms Unit dBμV

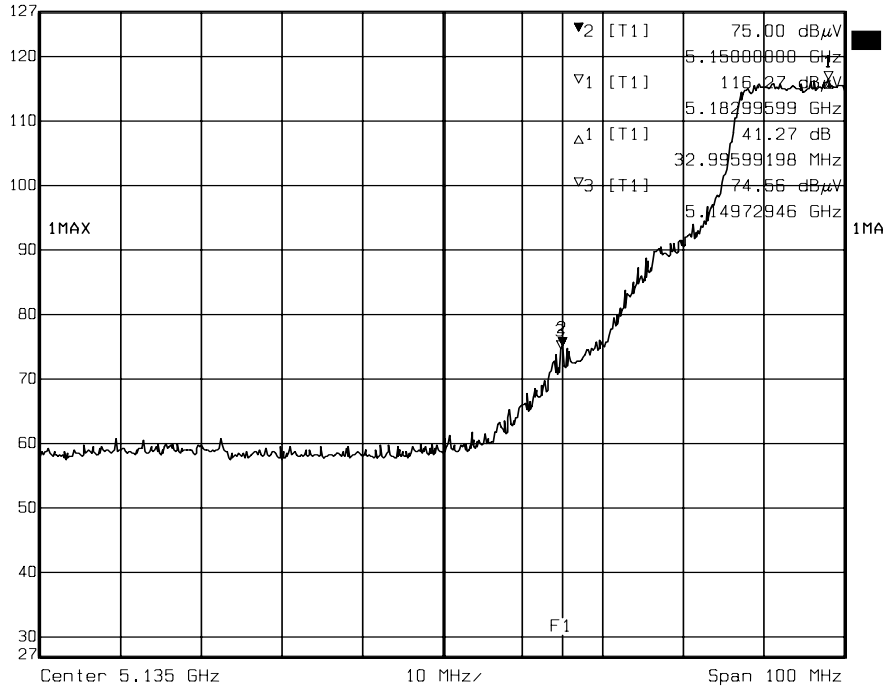

Date: 25.NOV.2004 17:00:40

Lower Band edge (Peak)

Marker 2 [T1] RBW 1 MHz RF Att 30 dB  
Ref Lvl 50.84 dBμV VBW 10 Hz  
127 dBμV 5.15000000 GHz SWT 25 s Unit dBμV

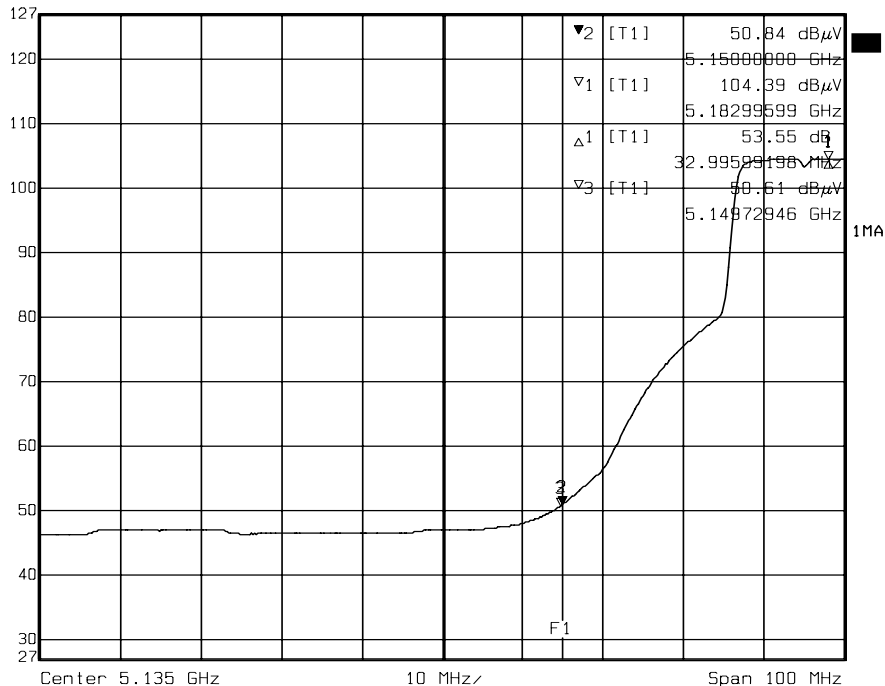

Date: 25.NOV.2004 17:01:47

Lower Band edge (Average)



**Carrier Frequency : 5320MHz**

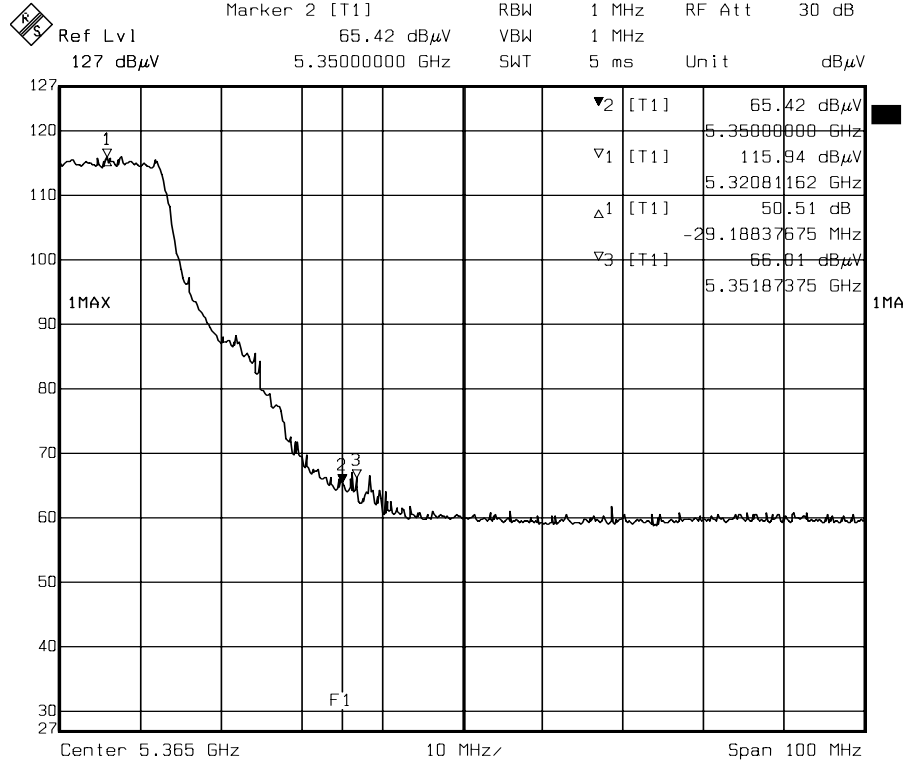

Date: 25.NOV.2004 17:08:03

**Higher Band edge (Peak)**

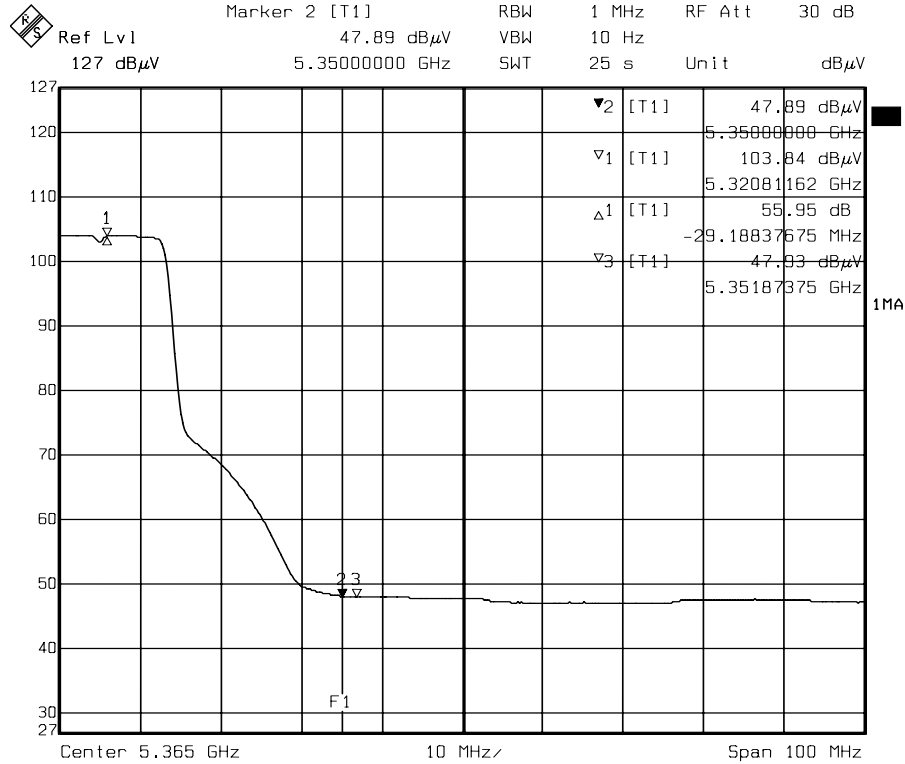

Date: 25.NOV.2004 17:09:32

**Higher Band edge (Average)**



**For Super A mode**  
**Carrier Frequency : 5210MHz**

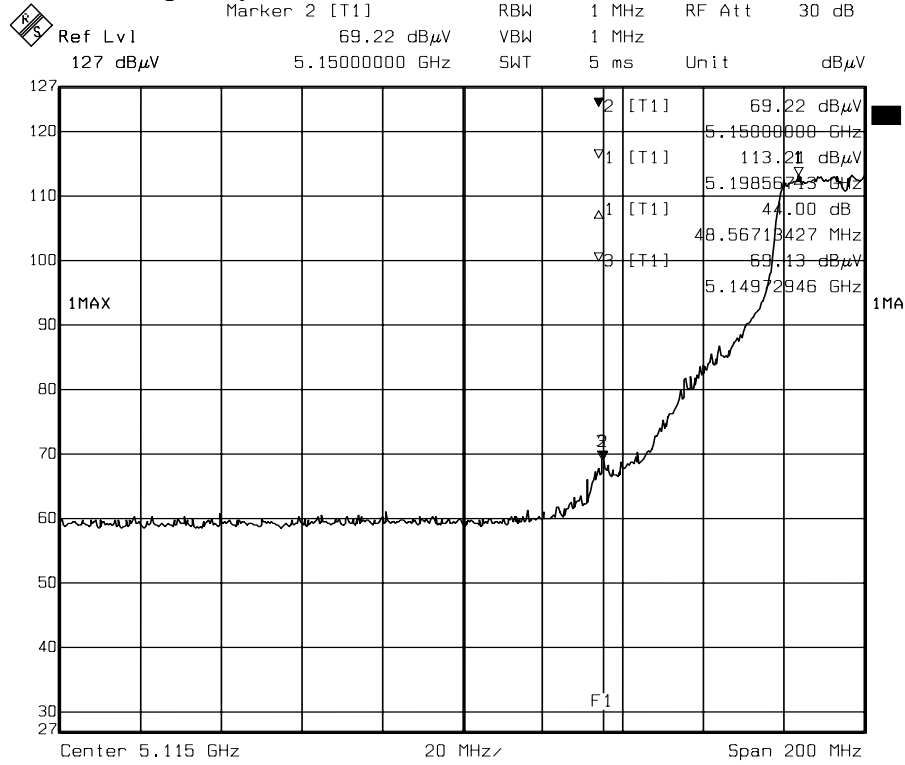

Date: 12.DEC.2004 09:48:56

Lower Band edge (Peak)

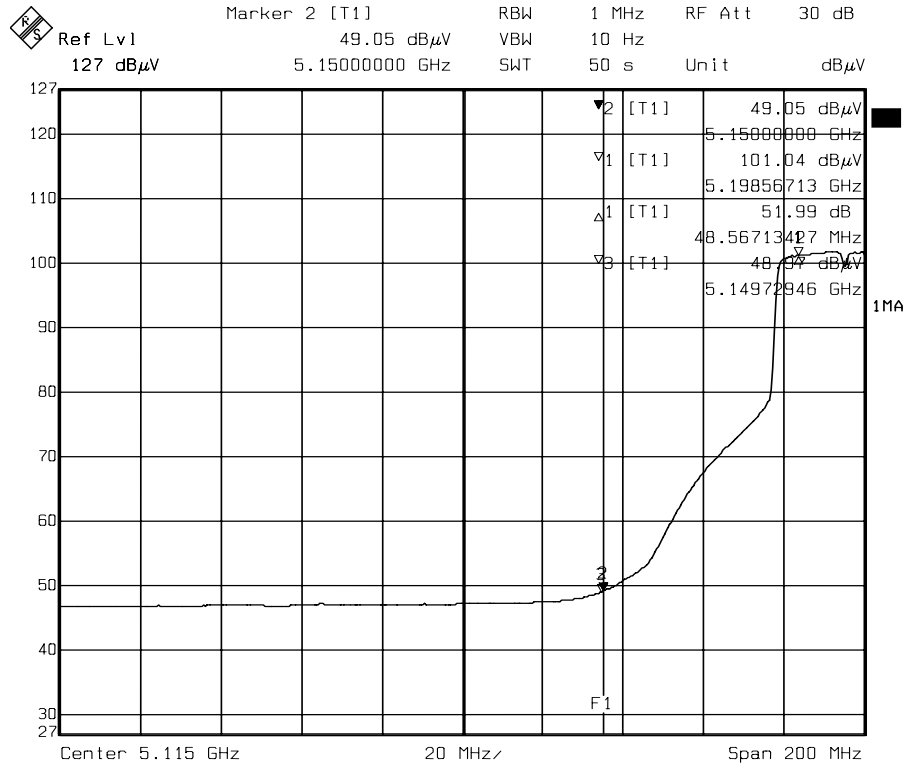

Date: 12.DEC.2004 09:50:50

Lower Band edge (Average)



**Carrier Frequency : 5290MHz**

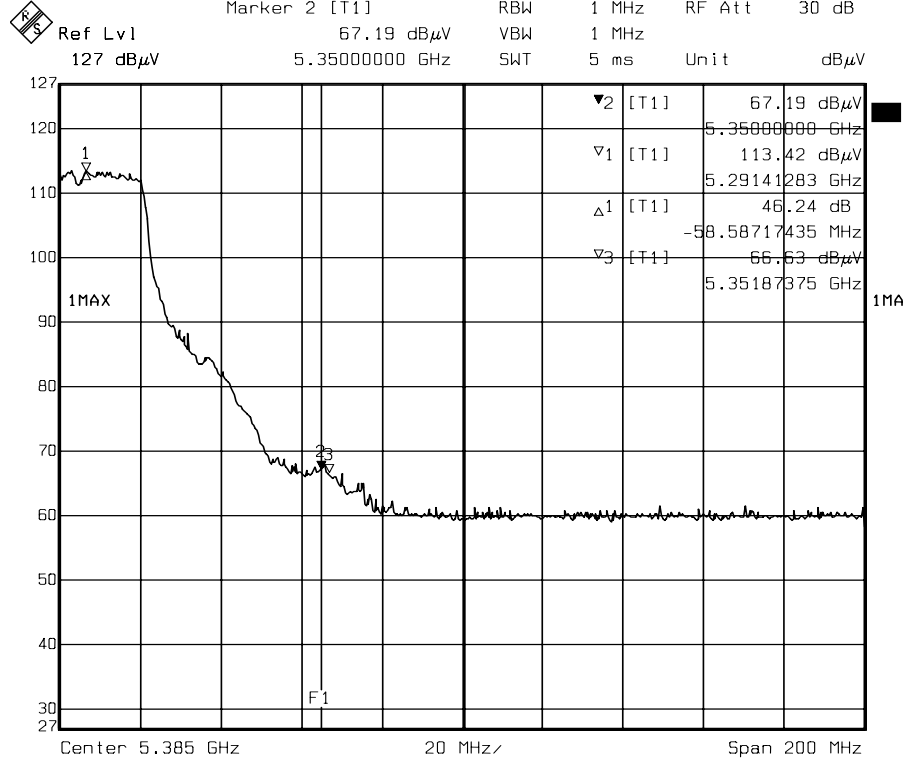

Date: 12.DEC.2004 09:59:39

**Higher Band edge (Peak)**

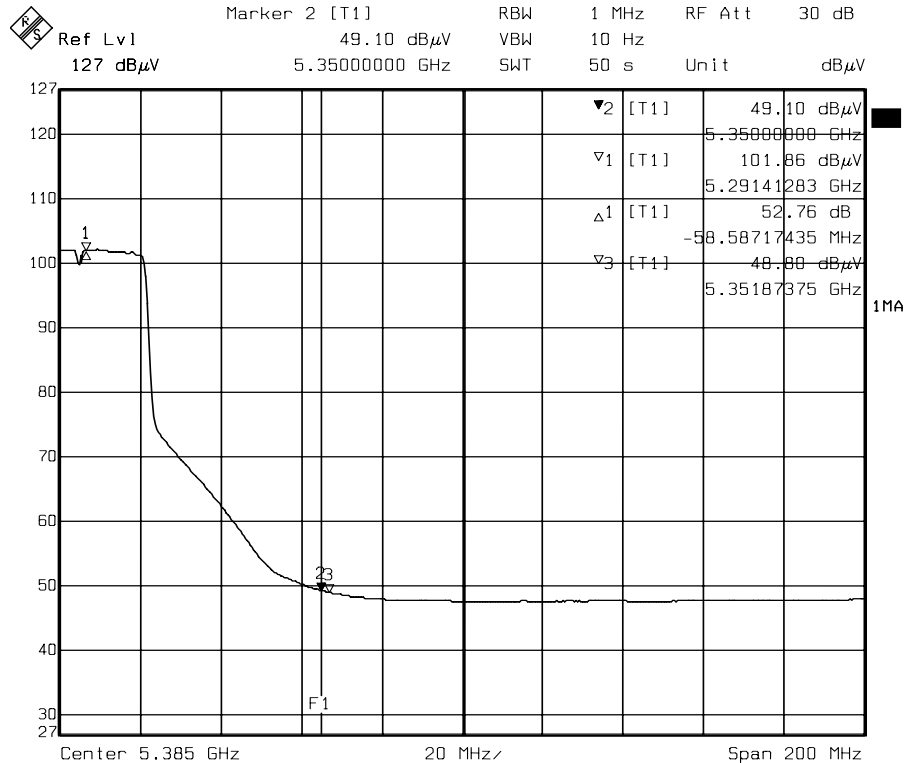

Date: 12.DEC.2004 10:01:38

**Higher Band edge (Average)**



### 3.6.5 Spurious Emission Outside of the 5.15 ~ 5.35GHz Band (RX)

The frequency spectrum above 1 GHz for Receiver was investigated. All emissions not reported are much lower than the prescribed limits. Readings are both peak and average values.

|                     |   |                            |             |
|---------------------|---|----------------------------|-------------|
| <b>Company</b>      | Netgear Incorporated                            | <b>Test Date</b>           | 2004/11/25  |
| <b>Product Name</b> | Double 108 Mbps Wireless USB 2.0 Adapter WG111U | <b>Test By</b>             | Alan Fan    |
| <b>Model Name</b>   | WG111U  | <b>TEMP &amp; Humidity</b> | 32.4°C, 51% |

| CH1 (5180MHz) RX |                |           |            | Measurement Distance at 1m Horizontal polarity |           |             |                |                |             |              |                |
|------------------|----------------|-----------|------------|--|-----------|-------------|----------------|----------------|-------------|--------------|----------------|
| Freq. (MHz)      | Reading (dBµV) | AF (dBµV) | Cable (dB) | Pre-amp (dB)                                   | Dist (dB) | Filter (dB) | Level (dBµV/m) | Limit (dBµV/m) | Margin (dB) | Mark (P/Q/A) | Height (Meter) |
| 1726.19          | 45.44          | 29.95     | 3.12       | 35.46  | 9.50      | 0.00        | 33.55          | 74.00          | -40.45      | P            | 1.03           |
| 1726.19          | 32.59          | 29.95     | 3.12       | 35.46  | 9.50      | 0.00        | 20.70          | 54.00          | -33.30      | A            | 1.03           |
| 3453.18          | 47.07          | 31.43     | 4.28       | 35.45  | 9.50      | 0.00        | 37.84          | 74.00          | -36.16      | P            | 1.12           |
| 3453.18          | 40.62          | 31.43     | 4.28       | 35.45  | 9.50      | 0.00        | 31.39          | 54.00          | -22.61      | A            | 1.12           |
| 6906.35          | 46.52          | 39.56     | 6.56       | 35.44  | 9.50      | 0.00        | 47.71          | 74.00          | -26.29      | P            | 1.16           |
| 6906.35          | 40.19          | 39.56     | 6.56       | 35.44  | 9.50      | 0.00        | 41.38          | 54.00          | -12.62      | A            | 1.16           |

1. AF: Antenna Factor, Cable: Cable Loss, Pre-Amp: Preamplifier gain.
2. Spectrum analyzer setting P(Peak): RBW=1MHz, VBW=1MHz, A(Average): RBW=1MHz, VBW=10Hz
3. Dist : correction to extra plate reading to 3m specification distance 1m measurement distance = -9.5dB
4. The result basic equation calculation as follow :  
Level = Reading + AF + Cable – Preamp + Filter – Dist, Margin = Level – Limit
5. The test limit is 3M limit.
6. The frequency was searched to 30GHz.
7. The other emission levels were very low against the limit.
8. For normal 802.11a mode.



# Ecom Sertech Corp.

Rm. 258, Bldg. 17, NO.195, Sec.4 Chung Hsing Rd., ChuTugn Chen, Hsinchu, Taiwan 310, R.O.C  
TEL: 886-3-5918012 FAX: 886-3-5825720

FCC ID : PY3WG111U

Report No. : ER04-11-043FRFa

Page 40 of 84

The frequency spectrum above 1 GHz for Receiver was investigated. All emissions not reported are much lower than the prescribed limits. Readings are both peak and average values.

|                     |   |                            |             |
|---------------------|---|----------------------------|-------------|
| <b>Company</b>      | Netgear Incorporated                            | <b>Test Date</b>           | 2004/11/25  |
| <b>Product Name</b> | Double 108 Mbps Wireless USB 2.0 Adapter WG111U | <b>Test By</b>             | Alan Fan    |
| <b>Model Name</b>   | WG111U  | <b>TEMP &amp; Humidity</b> | 32.4°C, 51% |

| CH1 (5180MHz) RX |                |           |            | Measurement Distance at 1m Vertical polarity |           |             |                |                |             |              |                |
|------------------|----------------|-----------|------------|--|-----------|-------------|----------------|----------------|-------------|--------------|----------------|
| Freq. (MHz)      | Reading (dBμV) | AF (dBμV) | Cable (dB) | Pre-amp (dB)                                 | Dist (dB) | Filter (dB) | Level (dBμV/m) | Limit (dBμV/m) | Margin (dB) | Mark (P/Q/A) | Height (Meter) |
| 1726.65          | 44.73          | 29.96     | 3.12       | 35.46  | 9.50      | 0.00        | 32.85          | 74.00          | -41.15      | P            | 1.00           |
| 1726.65          | 33.77          | 29.96     | 3.12       | 35.46  | 9.50      | 0.00        | 21.89          | 54.00          | -32.11      | A            | 1.00           |
| 3453.30          | 47.95          | 31.43     | 4.28       | 35.45  | 9.50      | 0.00        | 38.72          | 74.00          | -35.28      | P            | 1.15           |
| 3453.30          | 42.10          | 31.43     | 4.28       | 35.45  | 9.50      | 0.00        | 32.87          | 54.00          | -21.13      | A            | 1.15           |
| 6906.51          | 47.52          | 39.56     | 6.56       | 35.44  | 9.50      | 0.00        | 48.71          | 74.00          | -25.29      | P            | 1.10           |
| 6906.51          | 42.32          | 39.56     | 6.56       | 35.44  | 9.50      | 0.00        | 43.51          | 54.00          | -10.49      | A            | 1.10           |

1. AF: Antenna Factor, Cable: Cable Loss, Pre-Amp: Preamplifier gain.
2. Spectrum analyzer setting P(Peak): RBW=1MHz, VBW=1MHz, A(Average): RBW=1MHz, VBW=10Hz
3. Dist : correction to extra plate reading to 3m specification distance 1m measurement distance = -9.5dB
4. The result basic equation calculation as follow :  
Level = Reading + AF + Cable - Preamp + Filter - Dist, Margin = Level - Limit
5. The test limit is 3M limit.
6. The frequency was searched to 30GHz.
7. The other emission levels were very low against the limit.
8. For normal 802.11a mode.





# Ecom Sertech Corp.

Rm. 258, Bldg. 17, NO.195, Sec.4 Chung Hsing Rd., ChuTugn Chen, Hsinchu, Taiwan 310, R.O.C  
TEL: 886-3-5918012 FAX: 886-3-5825720

FCC ID : PY3WG111U

Report No. : ER04-11-043FRFa

Page 41 of 84

The frequency spectrum above 1 GHz for Receiver was investigated. All emissions not reported are much lower than the prescribed limits. Readings are both peak and average values.

|                     |   |                            |             |
|---------------------|---|----------------------------|-------------|
| <b>Company</b>      | Netgear Incorporated                            | <b>Test Date</b>           | 2004/11/25  |
| <b>Product Name</b> | Double 108 Mbps Wireless USB 2.0 Adapter WG111U | <b>Test By</b>             | Alan Fan    |
| <b>Model Name</b>   | WG111U  | <b>TEMP &amp; Humidity</b> | 32.4°C, 51% |

| CH4 (5240MHz) RX |                |           |            | Measurement Distance at 1m Horizontal polarity |           |             |                |                |             |              |                |
|------------------|----------------|-----------|------------|--|-----------|-------------|----------------|----------------|-------------|--------------|----------------|
| Freq. (MHz)      | Reading (dBμV) | AF (dBμV) | Cable (dB) | Pre-amp (dB)                                   | Dist (dB) | Filter (dB) | Level (dBμV/m) | Limit (dBμV/m) | Margin (dB) | Mark (P/Q/A) | Height (Meter) |
| 1746.50          | 44.23          | 30.12     | 3.14       | 35.45  | 9.50      | 0.00        | 32.54          | 74.00          | -41.46      | P            | 1.00           |
| 1746.50          | 32.89          | 30.12     | 3.14       | 35.45  | 9.50      | 0.00        | 21.20          | 54.00          | -32.80      | A            | 1.00           |
| 3493.13          | 47.10          | 31.40     | 4.32       | 35.41  | 9.50      | 0.00        | 37.92          | 74.00          | -36.08      | P            | 1.18           |
| 3493.13          | 39.76          | 31.40     | 4.32       | 35.41  | 9.50      | 0.00        | 30.58          | 54.00          | -23.42      | A            | 1.18           |
| 6986.41          | 46.89          | 39.85     | 6.58       | 35.66  | 9.50      | 0.00        | 48.16          | 74.00          | -25.84      | P            | 1.14           |
| 6986.41          | 38.88          | 39.85     | 6.58       | 35.66  | 9.50      | 0.00        | 40.15          | 54.00          | -13.85      | A            | 1.14           |

1. AF: Antenna Factor, Cable: Cable Loss, Pre-Amp: Preamplifier gain.
2. Spectrum analyzer setting P(Peak): RBW=1MHz, VBW=1MHz, A(Average): RBW=1MHz, VBW=10Hz
3. Dist : correction to extra plate reading to 3m specification distance 1m measurement distance = -9.5dB
4. The result basic equation calculation as follow :  
Level = Reading + AF + Cable - Preamp + Filter - Dist, Margin = Level - Limit
5. The test limit is 3M limit.
6. The frequency was searched to 30GHz.
7. The other emission levels were very low against the limit.
8. For normal 802.11a mode.



# Ecom Sertech Corp.

Rm. 258, Bldg. 17, NO.195, Sec.4 Chung Hsing Rd., ChuTugn Chen, Hsinchu, Taiwan 310, R.O.C  
TEL: 886-3-5918012 FAX: 886-3-5825720

FCC ID : PY3WG111U

Report No. : ER04-11-043FRFa

Page 42 of 84

The frequency spectrum above 1 GHz for Receiver was investigated. All emissions not reported are much lower than the prescribed limits. Readings are both peak and average values.

|                     |   |                            |             |
|---------------------|---|----------------------------|-------------|
| <b>Company</b>      | Netgear Incorporated                            | <b>Test Date</b>           | 2004/11/25  |
| <b>Product Name</b> | Double 108 Mbps Wireless USB 2.0 Adapter WG111U | <b>Test By</b>             | Alan Fan    |
| <b>Model Name</b>   | WG111U  | <b>TEMP &amp; Humidity</b> | 32.4°C, 51% |

| CH4 (5240MHz) RX |                |           |            | Measurement Distance at 1m Vertical polarity |           |             |                |                |             |              |                |
|------------------|----------------|-----------|------------|--|-----------|-------------|----------------|----------------|-------------|--------------|----------------|
| Freq. (MHz)      | Reading (dBμV) | AF (dBμV) | Cable (dB) | Pre-amp (dB)                                 | Dist (dB) | Filter (dB) | Level (dBμV/m) | Limit (dBμV/m) | Margin (dB) | Mark (P/Q/A) | Height (Meter) |
| 1746.42          | 45.78          | 30.12     | 3.14       | 35.45  | 9.50      | 0.00        | 34.09          | 74.00          | -39.91      | P            | 1.01           |
| 1746.42          | 33.89          | 30.12     | 3.14       | 35.45  | 9.50      | 0.00        | 22.20          | 54.00          | -31.80      | A            | 1.01           |
| 3493.20          | 48.14          | 31.40     | 4.32       | 35.41  | 9.50      | 0.00        | 38.96          | 74.00          | -35.04      | P            | 1.17           |
| 3493.20          | 41.50          | 31.40     | 4.32       | 35.41  | 9.50      | 0.00        | 32.32          | 54.00          | -21.68      | A            | 1.17           |
| 6986.46          | 47.82          | 39.85     | 6.58       | 35.66  | 9.50      | 0.00        | 49.09          | 74.00          | -24.91      | P            | 1.15           |
| 6986.46          | 41.90          | 39.85     | 6.58       | 35.66  | 9.50      | 0.00        | 43.17          | 54.00          | -10.83      | A            | 1.15           |

1. AF: Antenna Factor, Cable: Cable Loss, Pre-Amp: Preamplifier gain.
2. Spectrum analyzer setting P(Peak): RBW=1MHz, VBW=1MHz, A(Average): RBW=1MHz, VBW=10Hz
3. Dist : correction to extra plate reading to 3m specification distance 1m measurement distance = -9.5dB
4. The result basic equation calculation as follow :  
Level = Reading + AF + Cable - Preamp + Filter - Dist, Margin = Level - Limit
5. The test limit is 3M limit.
6. The frequency was searched to 30GHz.
7. The other emission levels were very low against the limit.
8. For normal 802.11a mode.



**Ecom Sertech Corp.**

Rm. 258, Bldg. 17, NO.195, Sec.4 Chung Hsing Rd., ChuTugn Chen, Hsinchu, Taiwan 310, R.O.C  
 TEL: 886-3-5918012 FAX: 886-3-5825720

FCC ID : PY3WG111U  
 Report No. : ER04-11-043FRFa  
 Page 43 of 84

The frequency spectrum above 1 GHz for Receiver was investigated. All emissions not reported are much lower than the prescribed limits. Readings are both peak and average values.

|                     |   |                            |             |
|---------------------|---|----------------------------|-------------|
| <b>Company</b>      | Netgear Incorporated                            | <b>Test Date</b>           | 2004/11/25  |
| <b>Product Name</b> | Double 108 Mbps Wireless USB 2.0 Adapter WG111U | <b>Test By</b>             | Alan Fan    |
| <b>Model Name</b>   | WG111U  | <b>TEMP &amp; Humidity</b> | 32.4°C, 51% |

| CH5 (5260MHz) RX |                |           |            | Measurement Distance at 1m Horizontal polarity |           |             |                |                |             |              |                |
|------------------|----------------|-----------|------------|--|-----------|-------------|----------------|----------------|-------------|--------------|----------------|
| Freq. (MHz)      | Reading (dBμV) | AF (dBμV) | Cable (dB) | Pre-amp (dB)                                   | Dist (dB) | Filter (dB) | Level (dBμV/m) | Limit (dBμV/m) | Margin (dB) | Mark (P/Q/A) | Height (Meter) |
| 1753.20          | 44.98          | 30.18     | 3.15       | 35.45  | 9.50      | 0.00        | 33.36          | 74.00          | -40.64      | P            | 1.00           |
| 1753.20          | 33.40          | 30.18     | 3.15       | 35.45  | 9.50      | 0.00        | 21.78          | 54.00          | -32.22      | A            | 1.00           |
| 3506.59          | 46.75          | 31.42     | 4.34       | 35.39  | 9.50      | 0.00        | 37.61          | 74.00          | -36.39      | P            | 1.29           |
| 3506.59          | 39.04          | 31.42     | 4.34       | 35.39  | 9.50      | 0.00        | 29.90          | 54.00          | -24.10      | A            | 1.29           |
| 7013.05          | 47.08          | 39.89     | 6.59       | 35.70  | 9.50      | 0.00        | 48.37          | 74.00          | -25.63      | P            | 1.12           |
| 7013.05          | 40.02          | 39.89     | 6.59       | 35.70  | 9.50      | 0.00        | 41.31          | 54.00          | -12.69      | A            | 1.12           |

1. AF: Antenna Factor, Cable: Cable Loss, Pre-Amp: Preamplifier gain.
2. Spectrum analyzer setting P(Peak): RBW=1MHz, VBW=1MHz, A(Average): RBW=1MHz, VBW=10Hz
3. Dist : correction to extra plate reading to 3m specification distance 1m measurement distance = -9.5dB
4. The result basic equation calculation as follow :  

$$\text{Level} = \text{Reading} + \text{AF} + \text{Cable} - \text{Preamp} + \text{Filter} - \text{Dist}, \text{Margin} = \text{Level} - \text{Limit}$$
5. The test limit is 3M limit.
6. The frequency was searched to 30GHz.
7. The other emission levels were very low against the limit.
8. For normal 802.11a mode.



**Ecom Sertech Corp.**

Rm. 258, Bldg. 17, NO.195, Sec.4 Chung Hsing Rd., ChuTugn Chen, Hsinchu, Taiwan 310, R.O.C  
 TEL: 886-3-5918012 FAX: 886-3-5825720

FCC ID : PY3WG111U  
 Report No. : ER04-11-043FRFa  
 Page 44 of 84

The frequency spectrum above 1 GHz for Receiver was investigated. All emissions not reported are much lower than the prescribed limits. Readings are both peak and average values.

|                     |   |                            |             |
|---------------------|---|----------------------------|-------------|
| <b>Company</b>      | Netgear Incorporated                            | <b>Test Date</b>           | 2004/11/25  |
| <b>Product Name</b> | Double 108 Mbps Wireless USB 2.0 Adapter WG111U | <b>Test By</b>             | Alan Fan    |
| <b>Model Name</b>   | WG111U  | <b>TEMP &amp; Humidity</b> | 32.4°C, 51% |

| CH5 (5260MHz) RX |                |           |            | Measurement Distance at 1m Vertical polarity |           |             |                |                |             |              |                |
|------------------|----------------|-----------|------------|--|-----------|-------------|----------------|----------------|-------------|--------------|----------------|
| Freq. (MHz)      | Reading (dBμV) | AF (dBμV) | Cable (dB) | Pre-amp (dB)                                 | Dist (dB) | Filter (dB) | Level (dBμV/m) | Limit (dBμV/m) | Margin (dB) | Mark (P/Q/A) | Height (Meter) |
| 1753.29          | 43.89          | 30.18     | 3.15       | 35.45  | 9.50      | 0.00        | 32.27          | 74.00          | -41.73      | P            | 1.00           |
| 1753.29          | 32.59          | 30.18     | 3.15       | 35.45  | 9.50      | 0.00        | 20.97          | 54.00          | -33.03      | A            | 1.00           |
| 3506.44          | 47.31          | 31.42     | 4.34       | 35.39  | 9.50      | 0.00        | 38.17          | 74.00          | -35.83      | P            | 1.05           |
| 3506.44          | 40.74          | 31.42     | 4.34       | 35.39  | 9.50      | 0.00        | 31.60          | 54.00          | -22.40      | A            | 1.05           |
| 7013.10          | 48.02          | 39.89     | 6.59       | 35.70  | 9.50      | 0.00        | 49.31          | 74.00          | -24.69      | P            | 1.17           |
| 7013.10          | 42.19          | 39.89     | 6.59       | 35.70  | 9.50      | 0.00        | 43.48          | 54.00          | -10.52      | A            | 1.17           |

1. AF: Antenna Factor, Cable: Cable Loss, Pre-Amp: Preamplifier gain.
2. Spectrum analyzer setting P(Peak): RBW=1MHz, VBW=1MHz, A(Average): RBW=1MHz, VBW=10Hz
3. Dist : correction to extra plate reading to 3m specification distance 1m measurement distance = -9.5dB
4. The result basic equation calculation as follow :  
 $Level = Reading + AF + Cable - Preamp + Filter - Dist, Margin = Level - Limit$
5. The test limit is 3M limit.
6. The frequency was searched to 30GHz.
7. The other emission levels were very low against the limit.
8. For normal 802.11a mode.



# Ecom Sertech Corp.

Rm. 258, Bldg. 17, NO.195, Sec.4 Chung Hsing Rd., ChuTugn Chen, Hsinchu, Taiwan 310, R.O.C  
TEL: 886-3-5918012 FAX: 886-3-5825720

FCC ID : PY3WG111U

Report No. : ER04-11-043FRFa

Page 45 of 84

The frequency spectrum above 1 GHz for Receiver was investigated. All emissions not reported are much lower than the prescribed limits. Readings are both peak and average values.

|                     |   |                            |             |
|---------------------|---|----------------------------|-------------|
| <b>Company</b>      | Netgear Incorporated                            | <b>Test Date</b>           | 2004/11/25  |
| <b>Product Name</b> | Double 108 Mbps Wireless USB 2.0 Adapter WG111U | <b>Test By</b>             | Alan Fan    |
| <b>Model Name</b>   | WG111U  | <b>TEMP &amp; Humidity</b> | 32.4°C, 51% |

| CH8 (5320MHz) RX |                |           |            | Measurement Distance at 1m Horizontal polarity |           |             |                |                |             |              |                |
|------------------|----------------|-----------|------------|--|-----------|-------------|----------------|----------------|-------------|--------------|----------------|
| Freq. (MHz)      | Reading (dBμV) | AF (dBμV) | Cable (dB) | Pre-amp (dB)                                   | Dist (dB) | Filter (dB) | Level (dBμV/m) | Limit (dBμV/m) | Margin (dB) | Mark (P/Q/A) | Height (Meter) |
| 1773.23          | 45.20          | 30.34     | 3.17       | 35.44  | 9.50      | 0.00        | 33.77          | 74.00          | -40.23      | P            | 1.02           |
| 1773.23          | 34.20          | 30.34     | 3.17       | 35.44  | 9.50      | 0.00        | 22.77          | 54.00          | -31.23      | A            | 1.02           |
| 3546.50          | 47.27          | 31.51     | 4.38       | 35.35  | 9.50      | 0.00        | 38.30          | 74.00          | -35.70      | P            | 1.21           |
| 3546.50          | 39.10          | 31.51     | 4.38       | 35.35  | 9.50      | 0.00        | 30.13          | 54.00          | -23.87      | A            | 1.21           |
| 7093.04          | 44.77          | 39.86     | 6.64       | 35.68  | 9.50      | 0.00        | 46.09          | 74.00          | -27.91      | P            | 1.00           |
| 7093.04          | 37.30          | 39.86     | 6.64       | 35.68  | 9.50      | 0.00        | 38.62          | 54.00          | -15.38      | A            | 1.00           |

1. AF: Antenna Factor, Cable: Cable Loss, Pre-Amp: Preamplifier gain.
2. Spectrum analyzer setting P(Peak): RBW=1MHz, VBW=1MHz, A(Average): RBW=1MHz, VBW=10Hz
3. Dist : correction to extra plate reading to 3m specification distance 1m measurement distance = -9.5dB
4. The result basic equation calculation as follow :  
Level = Reading + AF + Cable - Preamp + Filter - Dist, Margin = Level - Limit
5. The test limit is 3M limit.
6. The frequency was searched to 30GHz.
7. The other emission levels were very low against the limit.
8. For normal 802.11a mode.



# Ecom Sertech Corp.

Rm. 258, Bldg. 17, NO.195, Sec.4 Chung Hsing Rd., ChuTugn Chen, Hsinchu, Taiwan 310, R.O.C  
TEL: 886-3-5918012 FAX: 886-3-5825720

FCC ID : PY3WG111U

Report No. : ER04-11-043FRFa

Page 46 of 84

The frequency spectrum above 1 GHz for Receiver was investigated. All emissions not reported are much lower than the prescribed limits. Readings are both peak and average values.

|                     |   |                            |             |
|---------------------|---|----------------------------|-------------|
| <b>Company</b>      | Netgear Incorporated                            | <b>Test Date</b>           | 2004/11/25  |
| <b>Product Name</b> | Double 108 Mbps Wireless USB 2.0 Adapter WG111U | <b>Test By</b>             | Alan Fan    |
| <b>Model Name</b>   | WG111U  | <b>TEMP &amp; Humidity</b> | 32.4°C, 51% |

| CH8 (5320MHz) RX |                |           |            | Measurement Distance at 1m Vertical polarity |           |             |                |                |             |              |                |
|------------------|----------------|-----------|------------|--|-----------|-------------|----------------|----------------|-------------|--------------|----------------|
| Freq. (MHz)      | Reading (dBμV) | AF (dBμV) | Cable (dB) | Pre-amp (dB)                                 | Dist (dB) | Filter (dB) | Level (dBμV/m) | Limit (dBμV/m) | Margin (dB) | Mark (P/Q/A) | Height (Meter) |
| 1773.29          | 43.80          | 30.34     | 3.17       | 35.44  | 9.50      | 0.00        | 32.37          | 74.00          | -41.63      | P            | 1.00           |
| 1773.29          | 33.65          | 30.34     | 3.17       | 35.44  | 9.50      | 0.00        | 22.22          | 54.00          | -31.78      | A            | 1.00           |
| 3546.50          | 46.70          | 31.51     | 4.38       | 35.35  | 9.50      | 0.00        | 37.73          | 74.00          | -36.27      | P            | 1.00           |
| 3546.50          | 39.01          | 31.51     | 4.38       | 35.35  | 9.50      | 0.00        | 30.04          | 54.00          | -23.96      | A            | 1.00           |
| 7093.03          | 46.54          | 39.86     | 6.64       | 35.68  | 9.50      | 0.00        | 47.86          | 74.00          | -26.14      | P            | 1.15           |
| 7093.03          | 39.52          | 39.86     | 6.64       | 35.68  | 9.50      | 0.00        | 40.84          | 54.00          | -13.16      | A            | 1.15           |

1. AF: Antenna Factor, Cable: Cable Loss, Pre-Amp: Preamplifier gain.
2. Spectrum analyzer setting P(Peak): RBW=1MHz, VBW=1MHz, A(Average): RBW=1MHz, VBW=10Hz
3. Dist : correction to extra plate reading to 3m specification distance 1m measurement distance = -9.5dB
4. The result basic equation calculation as follow :  
Level = Reading + AF + Cable - Preamp + Filter - Dist, Margin = Level - Limit
5. The test limit is 3M limit.
6. The frequency was searched to 30GHz.
7. The other emission levels were very low against the limit.
8. For normal 802.11a mode.



**Ecom Sertech Corp.**

Rm. 258, Bldg. 17, NO.195, Sec.4 Chung Hsing Rd., ChuTugn Chen, Hsinchu, Taiwan 310, R.O.C  
 TEL: 886-3-5918012 FAX: 886-3-5825720

FCC ID : PY3WG111U  
 Report No. : ER04-11-043FRFa  
 Page 47 of 84

The frequency spectrum above 1 GHz for Receiver was investigated. All emissions not reported are much lower than the prescribed limits. Readings are both peak and average values.

|                     |   |                            |             |
|---------------------|---|----------------------------|-------------|
| <b>Company</b>      | Netgear Incorporated                            | <b>Test Date</b>           | 2004/12/12  |
| <b>Product Name</b> | Double 108 Mbps Wireless USB 2.0 Adapter WG111U | <b>Test By</b>             | Alan Fan    |
| <b>Model Name</b>   | WG111U  | <b>TEMP &amp; Humidity</b> | 21.2°C, 83% |

| Low (5210MHz) RX |                |           |            | Measurement Distance at 1m Horizontal polarity |           |             |                |                |             |              |                |
|------------------|----------------|-----------|------------|--|-----------|-------------|----------------|----------------|-------------|--------------|----------------|
| Freq. (MHz)      | Reading (dBμV) | AF (dBμV) | Cable (dB) | Pre-amp (dB)                                   | Dist (dB) | Filter (dB) | Level (dBμV/m) | Limit (dBμV/m) | Margin (dB) | Mark (P/Q/A) | Height (Meter) |
| 1736.20          | 46.12          | 30.04     | 3.13       | 35.46  | 9.50      | 0.00        | 34.33          | 74.00          | -39.67      | P            | 1.05           |
| 1736.20          | 33.02          | 30.04     | 3.13       | 35.46  | 9.50      | 0.00        | 21.23          | 54.00          | -32.77      | A            | 1.05           |
| 3473.41          | 48.95          | 31.42     | 4.30       | 35.43  | 9.50      | 0.00        | 39.74          | 74.00          | -34.26      | P            | 1.15           |
| 3473.41          | 41.20          | 31.42     | 4.30       | 35.43  | 9.50      | 0.00        | 31.99          | 54.00          | -22.01      | A            | 1.15           |
| 6946.75          | 47.00          | 39.71     | 6.57       | 35.55  | 9.50      | 0.00        | 48.23          | 74.00          | -25.77      | P            | 1.13           |
| 6946.75          | 39.98          | 39.71     | 6.57       | 35.55  | 9.50      | 0.00        | 41.21          | 54.00          | -12.79      | A            | 1.13           |

1. AF: Antenna Factor, Cable: Cable Loss, Pre-Amp: Preamplifier gain.
2. Spectrum analyzer setting P(Peak): RBW=1MHz, VBW=1MHz, A(Average): RBW=1MHz, VBW=10Hz
3. Dist : correction to extra plate reading to 3m specification distance 1m measurement distance = -9.5dB
4. The result basic equation calculation as follow :  

$$\text{Level} = \text{Reading} + \text{AF} + \text{Cable} - \text{Preamp} + \text{Filter} - \text{Dist}, \text{Margin} = \text{Level} - \text{Limit}$$
5. The test limit is 3M limit.
6. The frequency was searched to 30GHz.
7. The other emission levels were very low against the limit.
8. For Super A mode.



# Ecom Sertech Corp.

Rm. 258, Bldg. 17, NO.195, Sec.4 Chung Hsing Rd., ChuTugn Chen, Hsinchu, Taiwan 310, R.O.C  
TEL: 886-3-5918012 FAX: 886-3-5825720

FCC ID : PY3WG111U

Report No. : ER04-11-043FRFa

Page 48 of 84

The frequency spectrum above 1 GHz for Receiver was investigated. All emissions not reported are much lower than the prescribed limits. Readings are both peak and average values.

|                     |   |                            |             |
|---------------------|---|----------------------------|-------------|
| <b>Company</b>      | Netgear Incorporated                            | <b>Test Date</b>           | 2004/12/12  |
| <b>Product Name</b> | Double 108 Mbps Wireless USB 2.0 Adapter WG111U | <b>Test By</b>             | Alan Fan    |
| <b>Model Name</b>   | WG111U  | <b>TEMP &amp; Humidity</b> | 21.2°C, 83% |

| Low (5210MHz) RX |                |           |            | Measurement Distance at 1m Vertical polarity |           |             |                |                |             |              |                |
|------------------|----------------|-----------|------------|--|-----------|-------------|----------------|----------------|-------------|--------------|----------------|
| Freq. (MHz)      | Reading (dBμV) | AF (dBμV) | Cable (dB) | Pre-amp (dB)                                 | Dist (dB) | Filter (dB) | Level (dBμV/m) | Limit (dBμV/m) | Margin (dB) | Mark (P/Q/A) | Height (Meter) |
| 1736.19          | 45.12          | 30.04     | 3.13       | 35.46  | 9.50      | 0.00        | 33.33          | 74.00          | -40.67      | P            | 1.01           |
| 1736.19          | 34.01          | 30.04     | 3.13       | 35.46  | 9.50      | 0.00        | 22.22          | 54.00          | -31.78      | A            | 1.01           |
| 3473.50          | 48.56          | 31.42     | 4.30       | 35.43  | 9.50      | 0.00        | 39.35          | 74.00          | -34.65      | P            | 1.18           |
| 3473.50          | 41.87          | 31.42     | 4.30       | 35.43  | 9.50      | 0.00        | 32.66          | 54.00          | -21.34      | A            | 1.18           |
| 6946.62          | 46.52          | 39.71     | 6.57       | 35.55  | 9.50      | 0.00        | 47.75          | 74.00          | -26.25      | P            | 1.12           |
| 6946.62          | 41.74          | 39.71     | 6.57       | 35.55  | 9.50      | 0.00        | 42.97          | 54.00          | -11.03      | A            | 1.12           |

1. AF: Antenna Factor, Cable: Cable Loss, Pre-Amp: Preamplifier gain.
2. Spectrum analyzer setting P(Peak): RBW=1MHz, VBW=1MHz, A(Average): RBW=1MHz, VBW=10Hz
3. Dist : correction to extra plate reading to 3m specification distance 1m measurement distance = -9.5dB
4. The result basic equation calculation as follow :  
Level = Reading + AF + Cable - Preamp + Filter - Dist, Margin = Level - Limit
5. The test limit is 3M limit.
6. The frequency was searched to 30GHz.
7. The other emission levels were very low against the limit.
8. For Super A mode.





# Ecom Sertech Corp.

Rm. 258, Bldg. 17, NO.195, Sec.4 Chung Hsing Rd., ChuTugn Chen, Hsinchu, Taiwan 310, R.O.C  
TEL: 886-3-5918012 FAX: 886-3-5825720

FCC ID : PY3WG111U

Report No. : ER04-11-043FRFa

Page 49 of 84

The frequency spectrum above 1 GHz for Receiver was investigated. All emissions not reported are much lower than the prescribed limits. Readings are both peak and average values.

|                     |   |                            |             |
|---------------------|---|----------------------------|-------------|
| <b>Company</b>      | Netgear Incorporated                            | <b>Test Date</b>           | 2004/12/12  |
| <b>Product Name</b> | Double 108 Mbps Wireless USB 2.0 Adapter WG111U | <b>Test By</b>             | Alan Fan    |
| <b>Model Name</b>   | WG111U  | <b>TEMP &amp; Humidity</b> | 21.2°C, 83% |

| Middle (5250MHz) RX |                |           |            | Measurement Distance at 1m Horizontal polarity |           |             |                |                |             |              |                |
|---------------------|----------------|-----------|------------|--|-----------|-------------|----------------|----------------|-------------|--------------|----------------|
| Freq. (MHz)         | Reading (dBμV) | AF (dBμV) | Cable (dB) | Pre-amp (dB)                                   | Dist (dB) | Filter (dB) | Level (dBμV/m) | Limit (dBμV/m) | Margin (dB) | Mark (P/Q/A) | Height (Meter) |
| 1749.85             | 45.74          | 30.15     | 3.14       | 35.45  | 9.50      | 0.00        | 34.08          | 74.00          | -39.92      | P            | 1.11           |
| 1749.85             | 33.12          | 30.15     | 3.14       | 35.45  | 9.50      | 0.00        | 21.46          | 54.00          | -32.54      | A            | 1.11           |
| 3499.99             | 46.84          | 31.40     | 4.33       | 35.40  | 9.50      | 0.00        | 37.67          | 74.00          | -36.33      | P            | 1.18           |
| 3499.99             | 40.57          | 31.40     | 4.33       | 35.40  | 9.50      | 0.00        | 31.40          | 54.00          | -22.60      | A            | 1.18           |
| 6999.94             | 48.12          | 39.90     | 6.58       | 35.70  | 9.50      | 0.00        | 49.40          | 74.00          | -24.60      | P            | 1.16           |
| 6999.94             | 40.32          | 39.90     | 6.58       | 35.70  | 9.50      | 0.00        | 41.60          | 54.00          | -12.40      | A            | 1.16           |

1. AF: Antenna Factor, Cable: Cable Loss, Pre-Amp: Preamplifier gain.
2. Spectrum analyzer setting P(Peak): RBW=1MHz, VBW=1MHz, A(Average): RBW=1MHz, VBW=10Hz
3. Dist : correction to extra plate reading to 3m specification distance 1m measurement distance = -9.5dB
4. The result basic equation calculation as follow :  
Level = Reading + AF + Cable - Preamp + Filter - Dist, Margin = Level - Limit
5. The test limit is 3M limit.
6. The frequency was searched to 30GHz.
7. The other emission levels were very low against the limit.
8. For Super A mode.



# Ecom Sertech Corp.

Rm. 258, Bldg. 17, NO.195, Sec.4 Chung Hsing Rd., ChuTugn Chen, Hsinchu, Taiwan 310, R.O.C  
TEL: 886-3-5918012 FAX: 886-3-5825720

FCC ID : PY3WG111U

Report No. : ER04-11-043FRFa

Page 50 of 84

The frequency spectrum above 1 GHz for Receiver was investigated. All emissions not reported are much lower than the prescribed limits. Readings are both peak and average values.

|                     |   |                            |             |
|---------------------|---|----------------------------|-------------|
| <b>Company</b>      | Netgear Incorporated                            | <b>Test Date</b>           | 2004/12/12  |
| <b>Product Name</b> | Double 108 Mbps Wireless USB 2.0 Adapter WG111U | <b>Test By</b>             | Alan Fan    |
| <b>Model Name</b>   | WG111U  | <b>TEMP &amp; Humidity</b> | 21.2°C, 83% |

| Middle (5240MHz) RX |                |           |            | Measurement Distance at 1m Vertical polarity |           |             |                |                |             |              |                |
|---------------------|----------------|-----------|------------|--|-----------|-------------|----------------|----------------|-------------|--------------|----------------|
| Freq. (MHz)         | Reading (dBμV) | AF (dBμV) | Cable (dB) | Pre-amp (dB)                                 | Dist (dB) | Filter (dB) | Level (dBμV/m) | Limit (dBμV/m) | Margin (dB) | Mark (P/Q/A) | Height (Meter) |
| 1749.95             | 45.23          | 30.15     | 3.14       | 35.45  | 9.50      | 0.00        | 33.57          | 74.00          | -40.43      | P            | 1.03           |
| 1749.95             | 33.11          | 30.15     | 3.14       | 35.45  | 9.50      | 0.00        | 21.45          | 54.00          | -32.55      | A            | 1.03           |
| 3500.02             | 49.68          | 31.40     | 4.33       | 35.40  | 9.50      | 0.00        | 40.51          | 74.00          | -33.49      | P            | 1.15           |
| 3500.02             | 41.56          | 31.40     | 4.33       | 35.40  | 9.50      | 0.00        | 32.39          | 54.00          | -21.61      | A            | 1.15           |
| 6999.58             | 48.89          | 39.90     | 6.58       | 35.70  | 9.50      | 0.00        | 50.17          | 74.00          | -23.83      | P            | 1.10           |
| 6999.58             | 43.28          | 39.90     | 6.58       | 35.70  | 9.50      | 0.00        | 44.56          | 54.00          | -9.44       | A            | 1.10           |

1. AF: Antenna Factor, Cable: Cable Loss, Pre-Amp: Preamplifier gain.
2. Spectrum analyzer setting P(Peak): RBW=1MHz, VBW=1MHz, A(Average): RBW=1MHz, VBW=10Hz
3. Dist : correction to extra plate reading to 3m specification distance 1m measurement distance = -9.5dB
4. The result basic equation calculation as follow :  
Level = Reading + AF + Cable - Preamp + Filter - Dist, Margin = Level - Limit
5. The test limit is 3M limit.
6. The frequency was searched to 30GHz.
7. The other emission levels were very low against the limit.
8. For Super A mode.



# Ecom Sertech Corp.

Rm. 258, Bldg. 17, NO.195, Sec.4 Chung Hsing Rd., ChuTugn Chen, Hsinchu, Taiwan 310, R.O.C  
TEL: 886-3-5918012 FAX: 886-3-5825720

FCC ID : PY3WG111U

Report No. : ER04-11-043FRFa

Page 51 of 84

The frequency spectrum above 1 GHz for Receiver was investigated. All emissions not reported are much lower than the prescribed limits. Readings are both peak and average values.

|                     |   |                            |             |
|---------------------|---|----------------------------|-------------|
| <b>Company</b>      | Netgear Incorporated                            | <b>Test Date</b>           | 2004/12/12  |
| <b>Product Name</b> | Double 108 Mbps Wireless USB 2.0 Adapter WG111U | <b>Test By</b>             | Alan Fan    |
| <b>Model Name</b>   | WG111U  | <b>TEMP &amp; Humidity</b> | 21.2°C, 83% |

| High (5290MHz) RX |                |           |            | Measurement Distance at 1m Horizontal polarity |           |             |                |                |             |              |                |
|-------------------|----------------|-----------|------------|--|-----------|-------------|----------------|----------------|-------------|--------------|----------------|
| Freq. (MHz)       | Reading (dBμV) | AF (dBμV) | Cable (dB) | Pre-amp (dB)                                   | Dist (dB) | Filter (dB) | Level (dBμV/m) | Limit (dBμV/m) | Margin (dB) | Mark (P/Q/A) | Height (Meter) |
| 1763.25           | 44.23          | 30.26     | 3.16       | 35.44  | 9.50      | 0.00        | 32.71          | 74.00          | -41.29      | P            | 1.00           |
| 1763.25           | 33.87          | 30.26     | 3.16       | 35.44  | 9.50      | 0.00        | 22.35          | 54.00          | -31.65      | A            | 1.00           |
| 3526.41           | 49.52          | 31.46     | 4.36       | 35.37  | 9.50      | 0.00        | 40.47          | 74.00          | -33.53      | P            | 1.19           |
| 3526.41           | 41.23          | 31.46     | 4.36       | 35.37  | 9.50      | 0.00        | 32.18          | 54.00          | -21.82      | A            | 1.19           |
| 7052.98           | 45.23          | 39.88     | 6.62       | 35.69  | 9.50      | 0.00        | 46.54          | 74.00          | -27.46      | P            | 1.03           |
| 7052.98           | 38.12          | 39.88     | 6.62       | 35.69  | 9.50      | 0.00        | 39.43          | 54.00          | -14.57      | A            | 1.03           |

1. AF: Antenna Factor, Cable: Cable Loss, Pre-Amp: Preamplifier gain.
2. Spectrum analyzer setting P(Peak): RBW=1MHz, VBW=1MHz, A(Average): RBW=1MHz, VBW=10Hz
3. Dist : correction to extra plate reading to 3m specification distance 1m measurement distance = -9.5dB
4. The result basic equation calculation as follow :  
Level = Reading + AF + Cable - Preamp + Filter - Dist, Margin = Level - Limit
5. The test limit is 3M limit.
6. The frequency was searched to 30GHz.
7. The other emission levels were very low against the limit.
8. For Super A mode.



**Ecom Sertech Corp.**

Rm. 258, Bldg. 17, NO.195, Sec.4 Chung Hsing Rd., ChuTugn Chen, Hsinchu, Taiwan 310, R.O.C  
 TEL: 886-3-5918012 FAX: 886-3-5825720

FCC ID : PY3WG111U  
 Report No. : ER04-11-043FRFa  
 Page 52 of 84

The frequency spectrum above 1 GHz for Receiver was investigated. All emissions not reported are much lower than the prescribed limits. Readings are both peak and average values.

|                     |   |                            |             |
|---------------------|---|----------------------------|-------------|
| <b>Company</b>      | Netgear Incorporated                            | <b>Test Date</b>           | 2004/12/12  |
| <b>Product Name</b> | Double 108 Mbps Wireless USB 2.0 Adapter WG111U | <b>Test By</b>             | Alan Fan    |
| <b>Model Name</b>   | WG111U  | <b>TEMP &amp; Humidity</b> | 21.2°C, 83% |

| High (5290MHz) RX |                |           |            | Measurement Distance at 1m Vertical polarity |           |             |                |                |             |              |                |
|-------------------|----------------|-----------|------------|--|-----------|-------------|----------------|----------------|-------------|--------------|----------------|
| Freq. (MHz)       | Reading (dBμV) | AF (dBμV) | Cable (dB) | Pre-amp (dB)                                 | Dist (dB) | Filter (dB) | Level (dBμV/m) | Limit (dBμV/m) | Margin (dB) | Mark (P/Q/A) | Height (Meter) |
| 1763.30           | 45.12          | 30.26     | 3.16       | 35.44  | 9.50      | 0.00        | 33.60          | 74.00          | -40.40      | P            | 1.05           |
| 1763.30           | 34.14          | 30.26     | 3.16       | 35.44  | 9.50      | 0.00        | 22.62          | 54.00          | -31.38      | A            | 1.05           |
| 3526.62           | 47.56          | 31.46     | 4.36       | 35.37  | 9.50      | 0.00        | 38.51          | 74.00          | -35.49      | P            | 1.08           |
| 3526.62           | 40.11          | 31.46     | 4.36       | 35.37  | 9.50      | 0.00        | 31.06          | 54.00          | -22.94      | A            | 1.08           |
| 7053.15           | 47.12          | 39.88     | 6.62       | 35.69  | 9.50      | 0.00        | 48.43          | 74.00          | -25.57      | P            | 1.16           |
| 7053.15           | 40.03          | 39.88     | 6.62       | 35.69  | 9.50      | 0.00        | 41.34          | 54.00          | -12.66      | A            | 1.16           |

1. AF: Antenna Factor, Cable: Cable Loss, Pre-Amp: Preamplifier gain.
2. Spectrum analyzer setting P(Peak): RBW=1MHz, VBW=1MHz, A(Average): RBW=1MHz, VBW=10Hz
3. Dist : correction to extra plate reading to 3m specification distance 1m measurement distance = -9.5dB
4. The result basic equation calculation as follow :  
 $Level = Reading + AF + Cable - Preamp + Filter - Dist, Margin = Level - Limit$
5. The test limit is 3M limit.
6. The frequency was searched to 30GHz.
7. The other emission levels were very low against the limit.
8. For Super A mode.

### 3.7 Photos of Open Site





**Ecom Sertech Corp.**

Rm. 258, Bldg. 17, NO.195, Sec.4 Chung Hsing Rd., ChuTugn Chen, Hsinchu, Taiwan 310, R.O.C  
TEL: 886-3-5918012 FAX: 886-3-5825720

FCC ID : PY3WG111U

Report No. : ER04-11-043FRFa

Page 54 of 84





**Ecom Sertech Corp.**

Rm. 258, Bldg. 17, NO.195, Sec.4 Chung Hsing Rd., ChuTugn Chen, Hsinchu, Taiwan 310, R.O.C  
TEL: 886-3-5918012 FAX: 886-3-5825720

FCC ID : PY3WG111U

Report No. : ER04-11-043FRFa

Page 55 of 84

---





## 4. EMISSION BANDWIDTH MEASUREMENT

### 4.1 Test Equipments

| Description & Manufacturer        | Model No. | Serial No. | Date Of Calibration | Calibration Period |
|-----------------------------------|-----------|------------|---------------------|--------------------|
| ROHDE & SCHWARZ SPECTRUM ANALYZER | FSEK30    | 835253/002 | September 06, 2004  | 1 Year             |

Note :

1. The measurement uncertainty is less than +/- 2.6dB, which is calculated as per the NAMAS document NIS81.
2. The calibration interval of the above test instruments is 12 months and the calibrations are traceable to NML/ROC and NIST/USA.

### 4.2 Test Setup

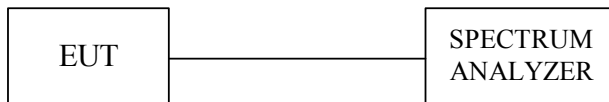

### 4.3 Test Procedure

- A. The transmitter output was connected to the spectrum analyzer.
- B. The bandwidth of the fundamental frequency was measured by spectrum analyzer with 300KHz RBW and 1MHz VBW.
- C. The 26dB bandwidth is defined as the total spectrum the power of which is higher than peak power minus 26dB.
- D. The measured Emission Bandwidth, B, is the 26dB bandwidth.

### 4.4 Uncertainty of Conducted Emission

The uncertainty of conducted emission is  $\pm 200\text{KHz}$ .





### 4.5 Test Results

|                     |   |                            |             |
|---------------------|---|----------------------------|-------------|
| <b>Company</b>      | Netgear Incorporated                            | <b>Test Date</b>           | 2004/12/13  |
| <b>Product Name</b> | Double 108 Mbps Wireless USB 2.0 Adapter WG111U | <b>Test By</b>             | Alan Fan    |
| <b>Model Name</b>   | WG111U  | <b>TEMP &amp; Humidity</b> | 21.1°C, 63% |

In 5.15 ~ 5.35 GHz Band  
For normal 802.11a mode

| <b>Channel</b> | <b>Channel Frequency (MHz)</b> | <b>26dB Bandwidth (MHz)</b> | <b>Pass / Fail</b> |
|----------------|--------------------------------|-----------------------------|--------------------|
| 1              | 5180                           | 25.45                       | PASS               |
| 4              | 5240                           | 26.35                       | PASS               |
| 5              | 5260                           | 26.85                       | PASS               |
| 8              | 5320                           | 25.05                       | PASS               |

For Super A mode

| <b>Channel</b> | <b>Channel Frequency (MHz)</b> | <b>26dB Bandwidth (MHz)</b> | <b>Pass / Fail</b> |
|----------------|--------------------------------|-----------------------------|--------------------|
| Low            | 5210                           | 49.50                       | PASS               |
| Middle         | 5250                           | 48.10                       | PASS               |
| High           | 5290                           | 47.50                       | PASS               |



### 4.6 Photo of 26db Bandwidth Measurement

#### In 5.15 ~ 5.35 GHz Band For normal 802.11a mode

|                |                 |     |         |        |            |
|----------------|-----------------|-----|---------|--------|------------|
|                | Delta 1 [T1]    | RBW | 300 kHz | RF Att | 30 dB      |
| Ref Lvl        | 0.19 dB         | VBW | 1 MHz   |        |            |
| 127 dB $\mu$ V | 25.45090180 MHz | SWT | 5 ms    | Unit   | dB $\mu$ V |

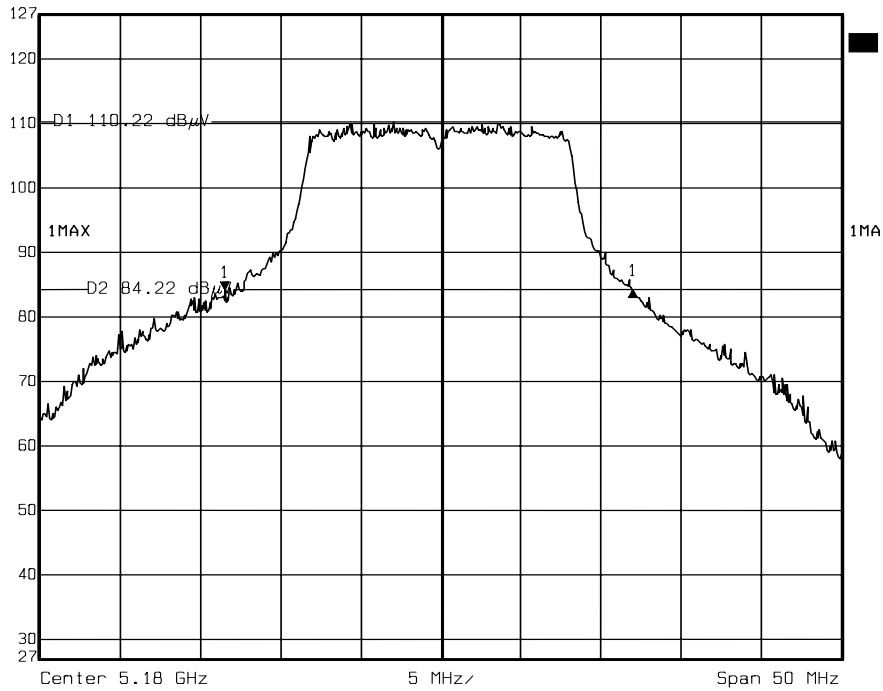

Date: 25.NOV.2004 15:47:45

Channel 1

|                |                 |     |         |        |            |
|----------------|-----------------|-----|---------|--------|------------|
|                | Delta 1 [T1]    | RBW | 300 kHz | RF Att | 30 dB      |
| Ref Lvl        | 0.84 dB         | VBW | 1 MHz   |        |            |
| 127 dB $\mu$ V | 26.35270541 MHz | SWT | 5 ms    | Unit   | dB $\mu$ V |

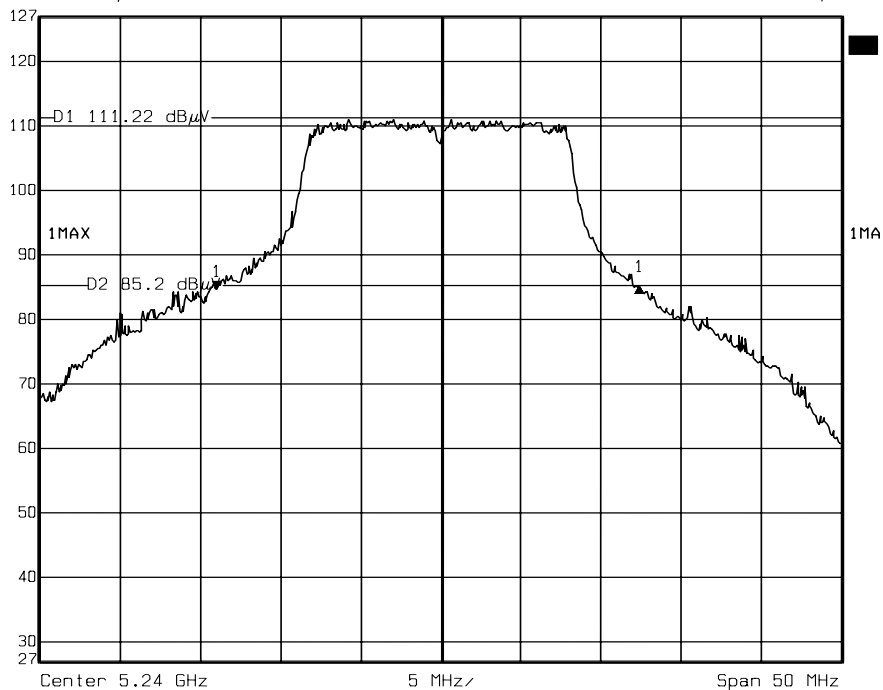

Date: 25.NOV.2004 15:50:01

Channel 4



# Ecom Sertech Corp.

Rm. 258, Bldg. 17, NO.195, Sec.4 Chung Hsing Rd., ChuTugn Chen, Hsinchu, Taiwan 310, R.O.C  
TEL: 886-3-5918012 FAX: 886-3-5825720

FCC ID : PY3WG111U

Report No. : ER04-11-043FRFa

Page 59 of 84

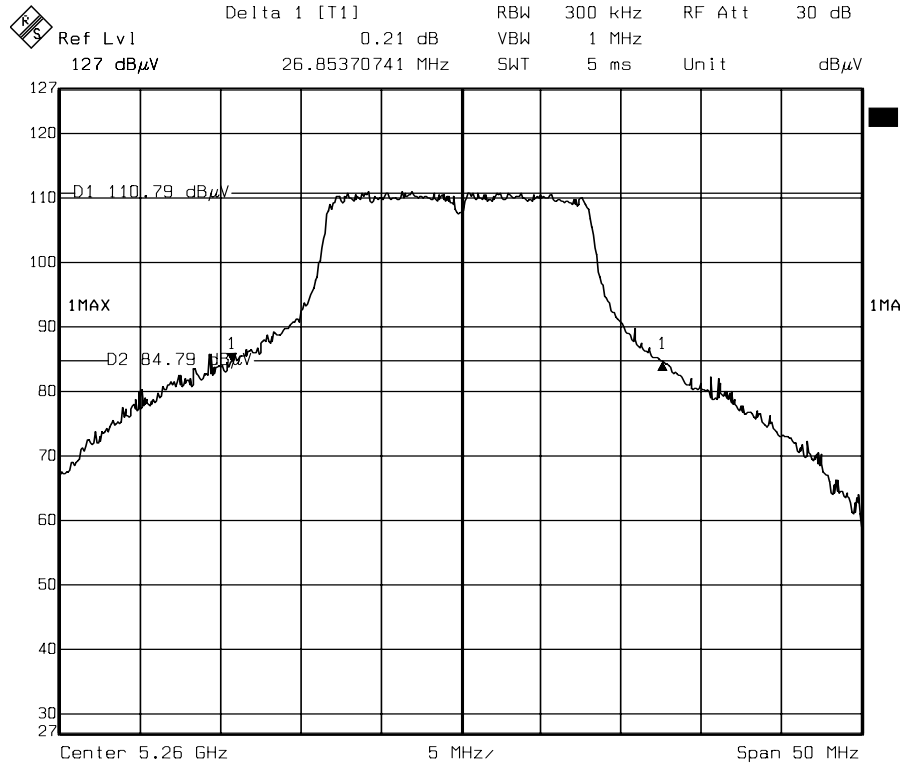

Date: 25.NOV.2004 15:54:39

## Channel 5

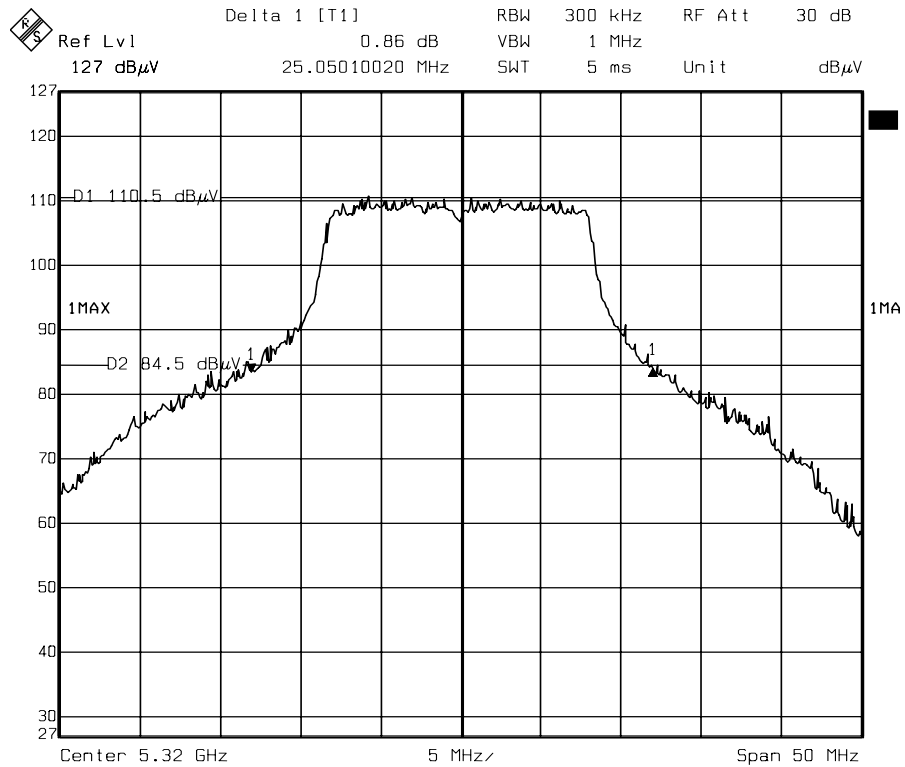

Date: 25.NOV.2004 15:56:20

## Channel 8



For Super A mode

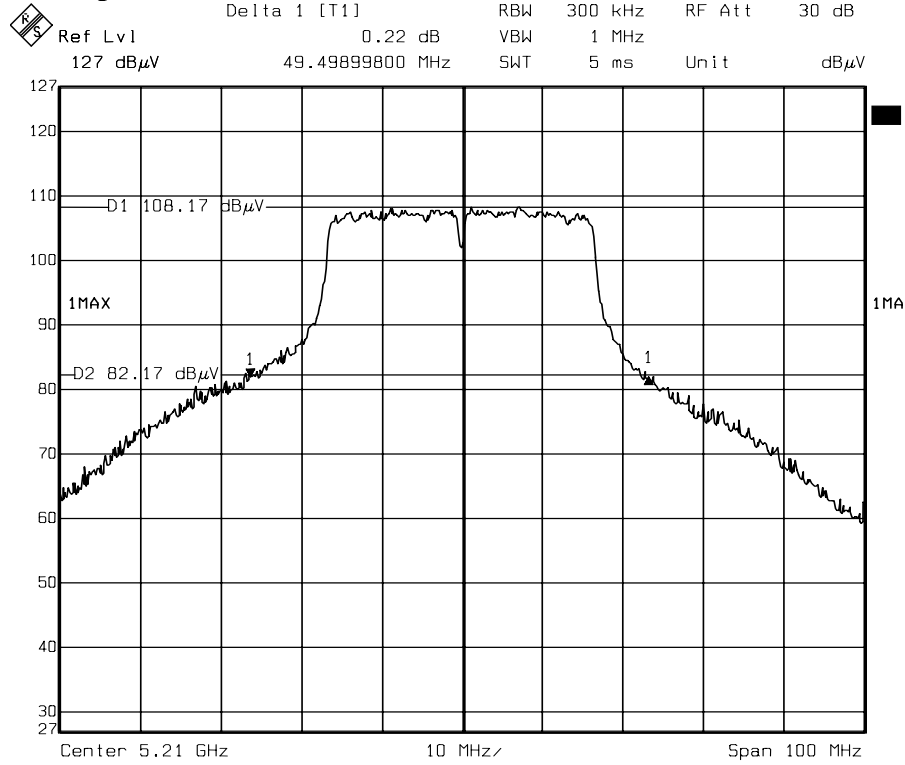

Date: 12.DEC.2004 09:36:20

Channel Low

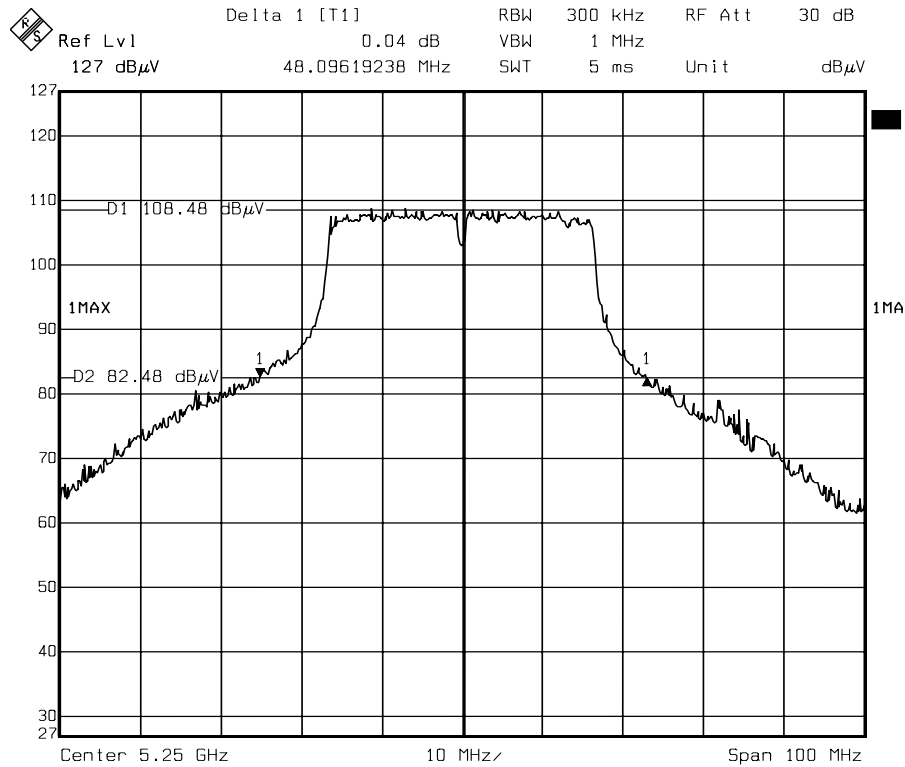

Date: 12.DEC.2004 07:04:29

Channel Middle



# Ecom Sertech Corp.

Rm. 258, Bldg. 17, NO.195, Sec.4 Chung Hsing Rd., ChuTugn Chen, Hsinchu, Taiwan 310, R.O.C  
TEL: 886-3-5918012 FAX: 886-3-5825720

FCC ID : PY3WG111U

Report No. : ER04-11-043FRFa

Page 61 of 84

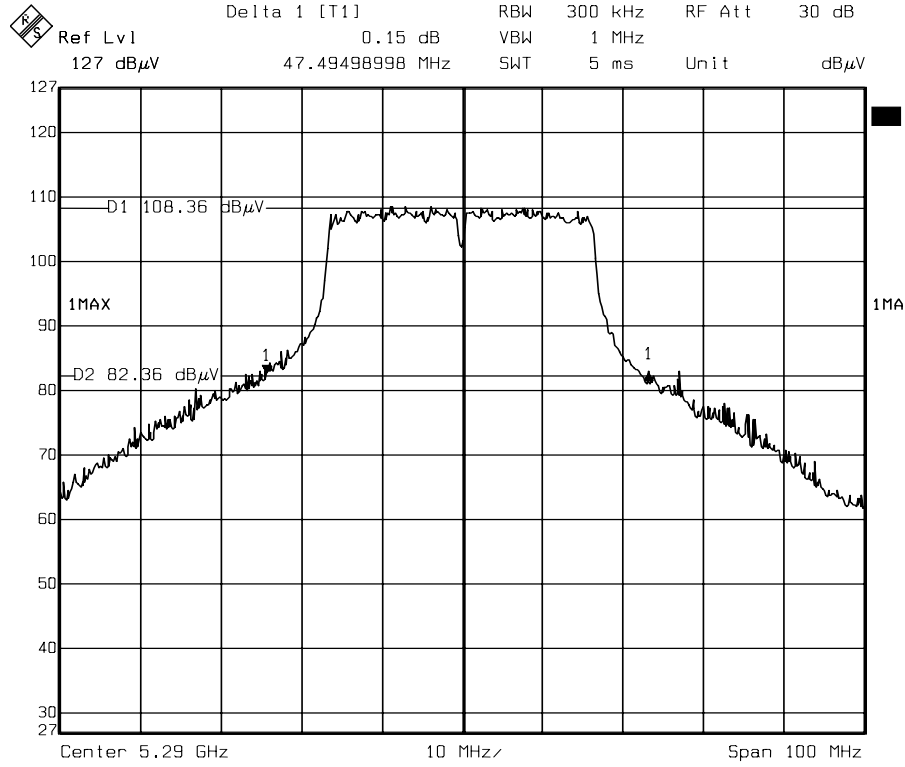

Channel High



## 5. PEAK CONDUCTED TRANSMIT POWER

### 5.1 Test Equipments

| Description & Manufacturer           | Model No. | Serial No. | Date Of Calibration   | Calibration Period |
|--------------------------------------|-----------|------------|-----------------------|--------------------|
| ROHDE & SCHWARZ<br>SPECTRUM ANALYZER | FSEK30    | 835253/002 | September 06,<br>2004 | 1 Year             |

Note :

1. The measurement uncertainty is less than +/- 2.6dB, which is calculated as per the NAMAS document NIS81.
2. The calibration interval of the above test instruments is 12 months and the calibrations are traceable to NML/ROC and NIST/USA.

### 5.2 Test Setup

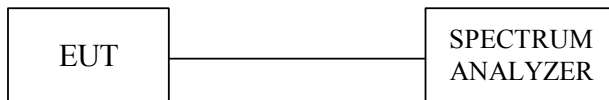



### 5.3 Limits of Maximum Peak Output Power

| Channel Frequency Band | FCC Output Power Limit (dBm) |
|------------------------|------------------------------|
| 5.15 ~ 5.25GHz Band    | 17 or 4+10logB               |
| 5.25 ~ 5.35GHz Band    | 24 or 11+10logB              |
| 5.47 ~ 5.725GHz Band   | 24 or 11+10logB              |
| 5.725 ~ 5.825GHz Band  | 30 or 17+10logB              |

For 5.15 ~ 5.25GHz band, If transmitting antennas of directional gain greater than 6 dBi are used, both the peak transmit power and the peak power spectral density shall be reduced by the amount in dB that the directional gain of the antenna exceeds 6 dBi.

For 5.25 ~ 5.35GHz and 5.47 ~ 5.725GHz, if transmitting antennas of directional gain greater than 6 dBi are used, both the peak transmit power and the peak power spectral density shall be reduced by the amount in dB that the directional gain of the antenna exceeds 6 dBi.

For 5.725 ~ 5.825GHz band, if transmitting antennas of directional gain greater than 6 dBi are used, both the peak transmit power and the peak power spectral density shall be reduced by the amount in dB that the directional gain of the antenna exceeds 6 dBi. However, fixed point-to-point U-NII devices operating in this band may employ transmitting antennas with directional gain up to 23 dBi without any corresponding reduction in the transmitter peak output power or peak power spectral density. For fixed, point-to-point U-NII transmitters that employ a directional antenna gain greater than 23 dBi, a 1 dB reduction in peak transmitter power and peak power spectral density for each 1 dB of antenna gain in excess of 23 dBi would be required.

### 5.4 Test Procedure

1. Set span to encompass the entire emission bandwidth (EBW) of the signal.  
Set RBW = 1 MHz.  
Set VBW=1 MHz.
2. Use sample detector mode if bin width (i.e., span/number of points in spectrum display) < 0.5 RBW. Otherwise use peak detector mode.
3. Transmitter must operate at full control power for entire sweep of every sweep.
4. If the device transmits continuously, with no off intervals or reduced power intervals, the trigger may be set to “free run”.
5. Trace average 100 traces in power averaging mode.
6. Compute power by integrating the spectrum across the 26 dB EBW of the signal

### 5.5 Uncertainty of Conducted Emission

The uncertainty of conducted emission is  $\pm 1.82$ dB.



## Ecom Sertech Corp.

Rm. 258, Bldg. 17, NO.195, Sec.4 Chung Hsing Rd., ChuTugn Chen, Hsinchu, Taiwan 310, R.O.C  
TEL: 886-3-5918012 FAX: 886-3-5825720

FCC ID : PY3WG111U

Report No. : ER04-11-043FRFa

Page 64 of 84

### 5.6 Test Results

|                     |   |                            |             |
|---------------------|---|----------------------------|-------------|
| <b>Company</b>      | Netgear Incorporated                            | <b>Test Date</b>           | 2004/12/13  |
| <b>Product Name</b> | Double 108 Mbps Wireless USB 2.0 Adapter WG111U | <b>Test By</b>             | Alan Fan    |
| <b>Model Name</b>   | WG111U  | <b>TEMP &amp; Humidity</b> | 21.1°C, 63% |

In 5.15 ~ 5.35 GHz Band

For normal 802.11a mode

Cable loss = 0.5dB

| Channel | Channel Frequency (MHz) | 26dB Bandwidth (MHz) | Output Power (dBm) | FCC Output Power Limit (dBm) | Pass / Fail |
|---------|-------------------------|----------------------|--------------------|------------------------------|-------------|
| 1       | 5180                    | 25.45                | 16.01              | 17                           | PASS        |
| 4       | 5240                    | 26.35                | 16.20              | 17                           | PASS        |
| 5       | 5260                    | 26.85                | 16.19              | 24                           | PASS        |
| 8       | 5320                    | 25.05                | 16.37              | 24                           | PASS        |

For Super A mode

Cable loss = 0.5dB

| Channel | Channel Frequency (MHz) | 26dB Bandwidth (MHz) | Output Power (dBm) | FCC Output Power Limit (dBm) | Pass / Fail |
|---------|-------------------------|----------------------|--------------------|------------------------------|-------------|
| Low     | 5210                    | 49.50                | 16.30              | 17                           | PASS        |
| Middle  | 5250                    | 48.10                | 15.84              | 17                           | PASS        |
| High    | 5290                    | 47.50                | 16.06              | 24                           | PASS        |





### 5.7 Photo of Peak Conducted Transmit Power Measurement

In 5.15 ~ 5.35 GHz Band  
For normal 802.11a mode

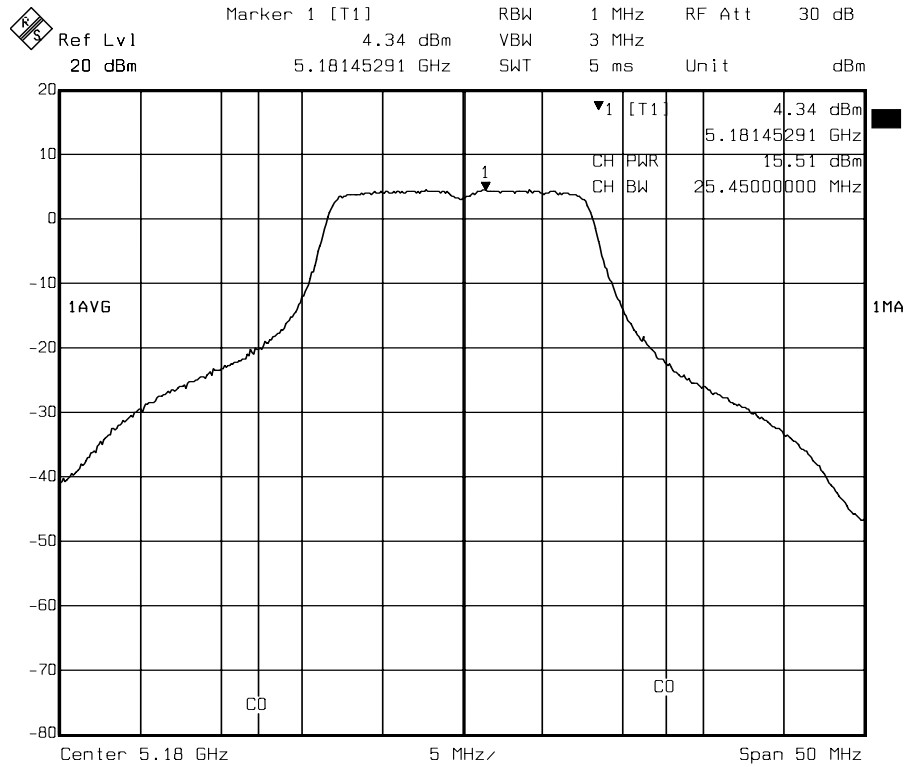

Channel 1

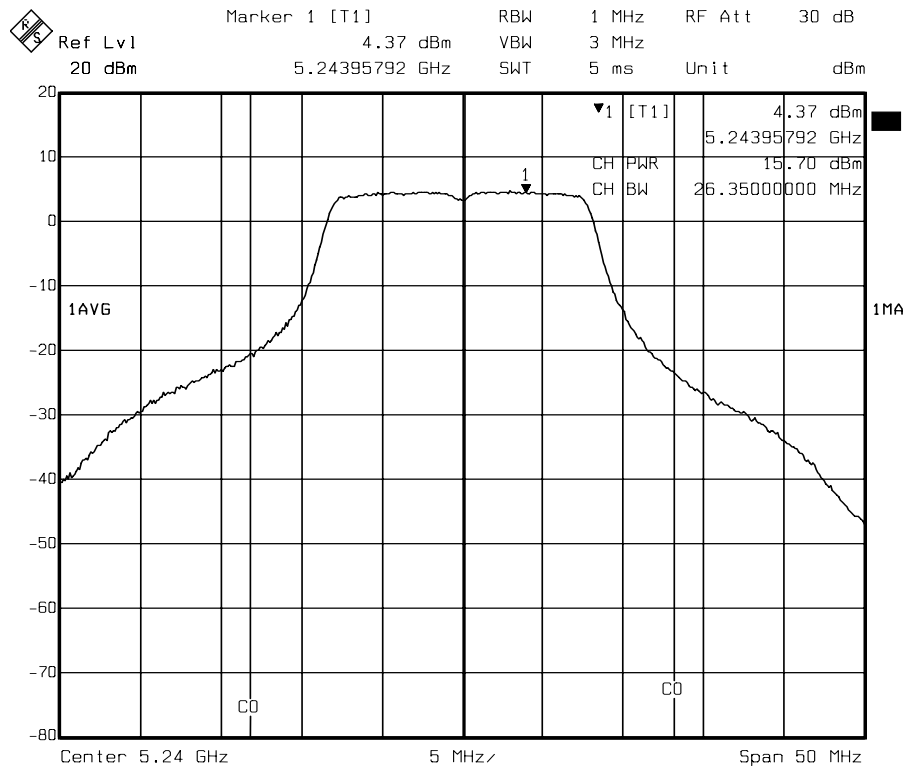

Channel 4



# Ecom Sertech Corp.

Rm. 258, Bldg. 17, NO.195, Sec.4 Chung Hsing Rd., ChuTugn Chen, Hsinchu, Taiwan 310, R.O.C  
TEL: 886-3-5918012 FAX: 886-3-5825720

FCC ID : PY3WG111U

Report No. : ER04-11-043FRFa

Page 66 of 84

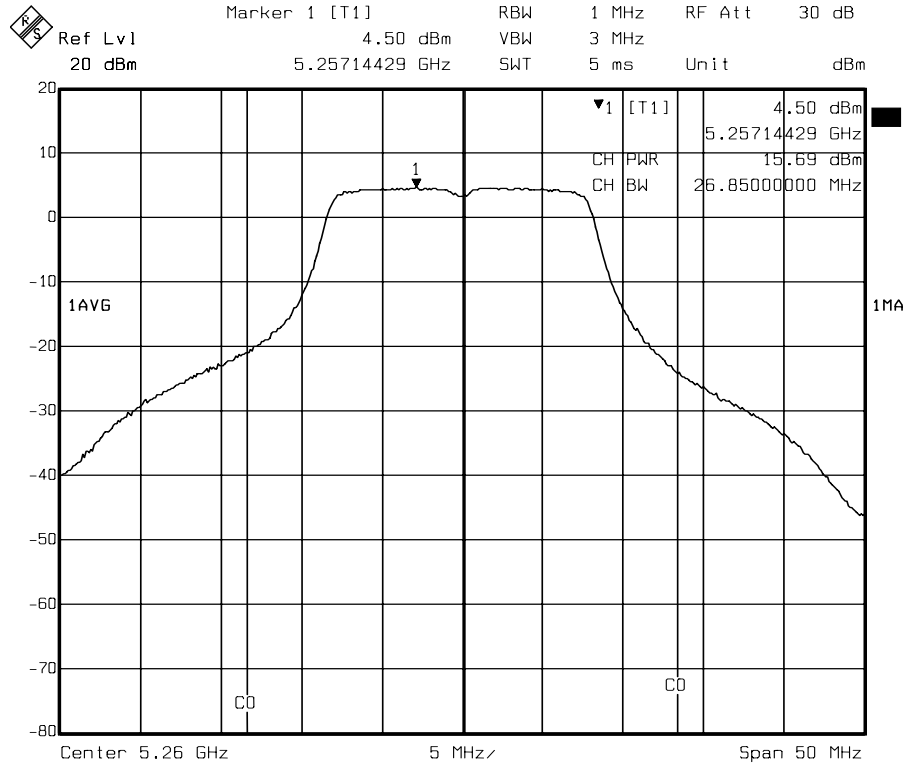

Date: 04.DEC.2004 14:42:31

## Channel 5

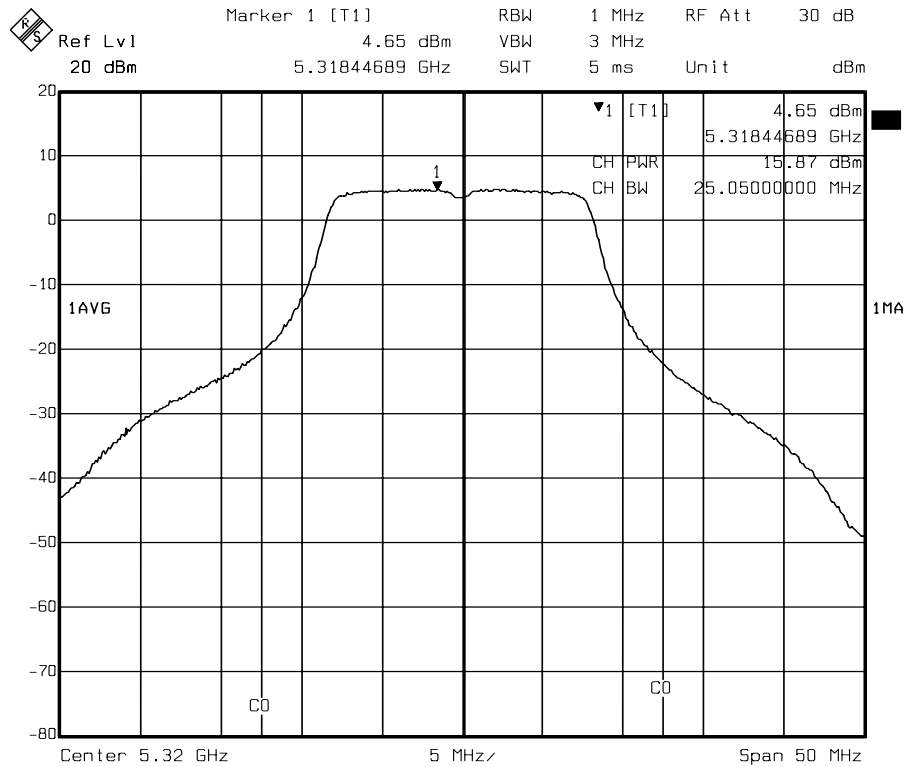

Date: 04.DEC.2004 14:49:00

## Channel 8



# Ecom Sertech Corp.

Rm. 258, Bldg. 17, NO.195, Sec.4 Chung Hsing Rd., ChuTugn Chen, Hsinchu, Taiwan 310, R.O.C  
TEL: 886-3-5918012 FAX: 886-3-5825720

FCC ID : PY3WG111U

Report No. : ER04-11-043FRFa

Page 67 of 84

## For Super A mode

Marker 1 [T1] RBW 1 MHz RF Att 30 dB  
Ref Lvl 1.66 dBm VBW 3 MHz  
20 dBm 5.20609218 GHz SWT 5 ms Unit dBm

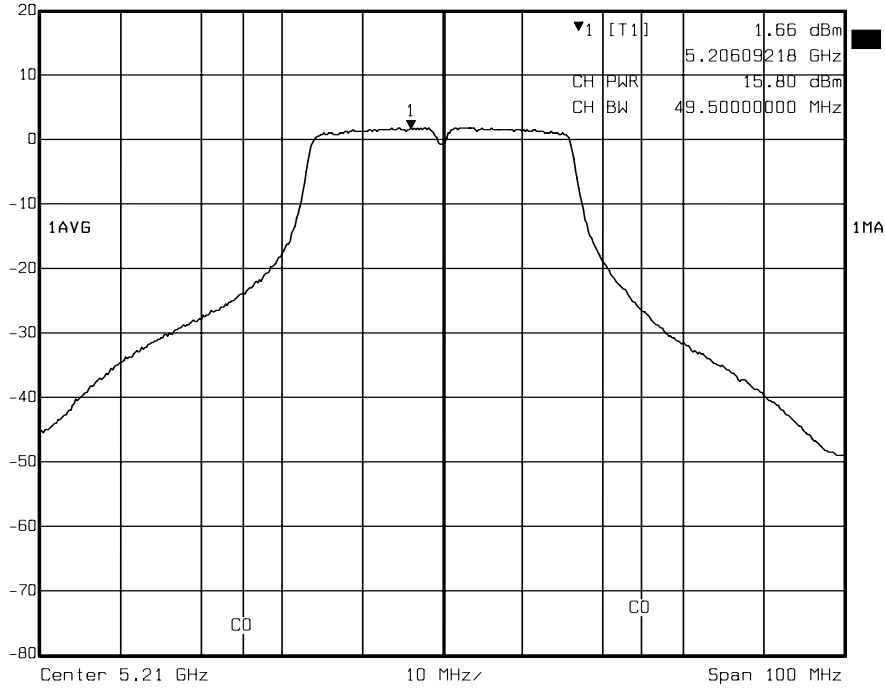

Date: 12.DEC.2004 10:51:29

### Channel Low

Marker 1 [T1] RBW 1 MHz RF Att 30 dB  
Ref Lvl 1.25 dBm VBW 3 MHz  
20 dBm 5.25350701 GHz SWT 5 ms Unit dBm

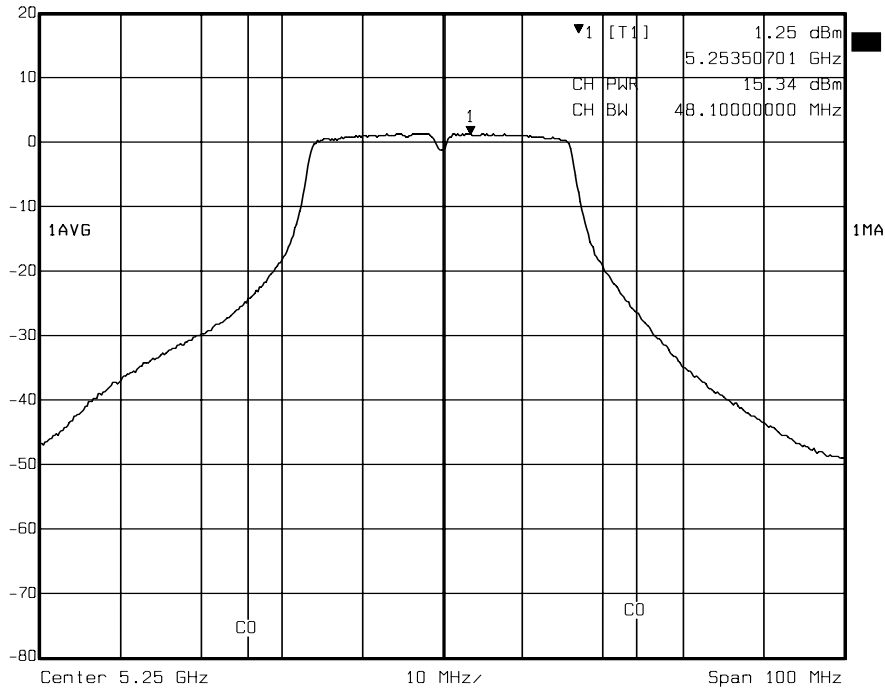

Date: 12.DEC.2004 10:55:56

### Channel Middle



# Ecom Sertech Corp.

Rm. 258, Bldg. 17, NO.195, Sec.4 Chung Hsing Rd., ChuTugn Chen, Hsinchu, Taiwan 310, R.O.C  
TEL: 886-3-5918012 FAX: 886-3-5825720

FCC ID : PY3WG111U

Report No. : ER04-11-043FRFa

Page 68 of 84

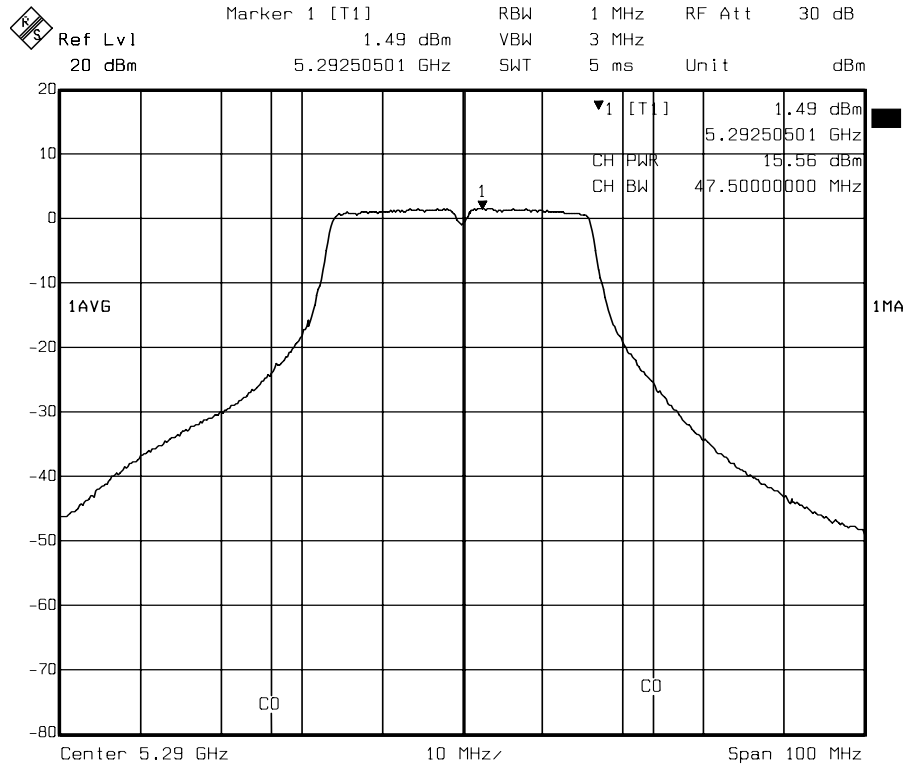

Date: 12.DEC.2004 10:59:03

Channel High



## 6. PEAK POWER DENSITY MEASUREMENT

### 6.1 Test Equipments

| Description & Manufacturer        | Model No. | Serial No. | Date Of Calibration | Calibration Period |
|-----------------------------------|-----------|------------|---------------------|--------------------|
| ROHDE & SCHWARZ SPECTRUM ANALYZER | FSEK30    | 835253/002 | September 06, 2004  | 1 Year             |

Note :

1. The measurement uncertainty is less than +/- 2.6dB, which is calculated as per the NAMAS document NIS81.
2. The calibration interval of the above test instruments is 12 months and the calibrations are traceable to NML/ROC and NIST/USA.

### 6.2 Test Setup

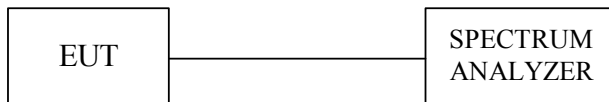

### 6.3 Limits of Power Spectral Density Measurement

| Channel Frequency Band | FCC Peak Power Spectrum density Limit (dBm) |
|------------------------|---|
| 5.15 ~ 5.25GHz Band    | 4 dBm/MHz                                   |
| 5.25 ~ 5.35GHz Band    | 11dBm/MHz                                   |
| 5.47 ~ 5.725GHz Band   | 11 dBm/MHz                                  |
| 5.725 ~ 5.825GHz Band  | 17 dBm/MHz                                  |



### 6.4 Test Procedure

The transmitter output was connected to the spectrum analyzer through an attenuator, the bandwidth of the fundamental frequency was measured with the spectrum analyzer using 1MHz RBW and 3MHz VBW. The power spectral density was measured and recorded.

### 6.5 Uncertainty of Conducted Emission

The uncertainty of conducted emission is  $\pm 1.82$ dB.

### 6.6 Test Results

|                     |   |                            |             |
|---------------------|---|----------------------------|-------------|
| <b>Company</b>      | Netgear Incorporated                            | <b>Test Date</b>           | 2004/12/13  |
| <b>Product Name</b> | Double 108 Mbps Wireless USB 2.0 Adapter WG111U | <b>Test By</b>             | Alan Fan    |
| <b>Model Name</b>   | WG111U  | <b>TEMP &amp; Humidity</b> | 21.1°C, 63% |

In 5.15 ~ 5.35 GHz Band  
For normal 802.11a mode

Cable loss = 0.5dB

| Channel | Channel Frequency (MHz) | 26dB Bandwidth (MHz) | Peak Power Spectrum density (dBm) | FCC Peak Power Spectrum density Limit (dBm) | Pass / Fail |
|---------|-------------------------|----------------------|-----------------------------------|---|-------------|
| 1       | 5180                    | 25.45                | -2.06                             | 4 dBm/MHz                                   | PASS        |
| 4       | 5240                    | 26.35                | -2.37                             | 4 dBm/MHz                                   | PASS        |
| 5       | 5260                    | 26.85                | -1.41                             | 11 dBm/MHz                                  | PASS        |
| 8       | 5320                    | 25.05                | -2.41                             | 17 dBm/MHz                                  | PASS        |

For Super A mode

Cable loss = 0.5dB

| Channel | Channel Frequency (MHz) | 26dB Bandwidth (MHz) | Peak Power Spectrum density (dBm) | FCC Peak Power Spectrum density Limit (dBm) | Pass / Fail |
|---------|-------------------------|----------------------|-----------------------------------|---|-------------|
| Low     | 5210                    | 49.50                | -3.36                             | 4 dBm/MHz                                   | PASS        |
| Middle  | 5250                    | 48.10                | -3.06                             | 4 dBm/MHz                                   | PASS        |
| High    | 5290                    | 47.50                | -4.03                             | 11 dBm/MHz                                  | PASS        |

Note : Peak Power spectrum density test result = peak power spectrum density reading + cable loss.



### 6.7 Photo of Peak Power Density Measurement

In 5.15 ~ 5.35GHz Band  
For normal 802.11a mode

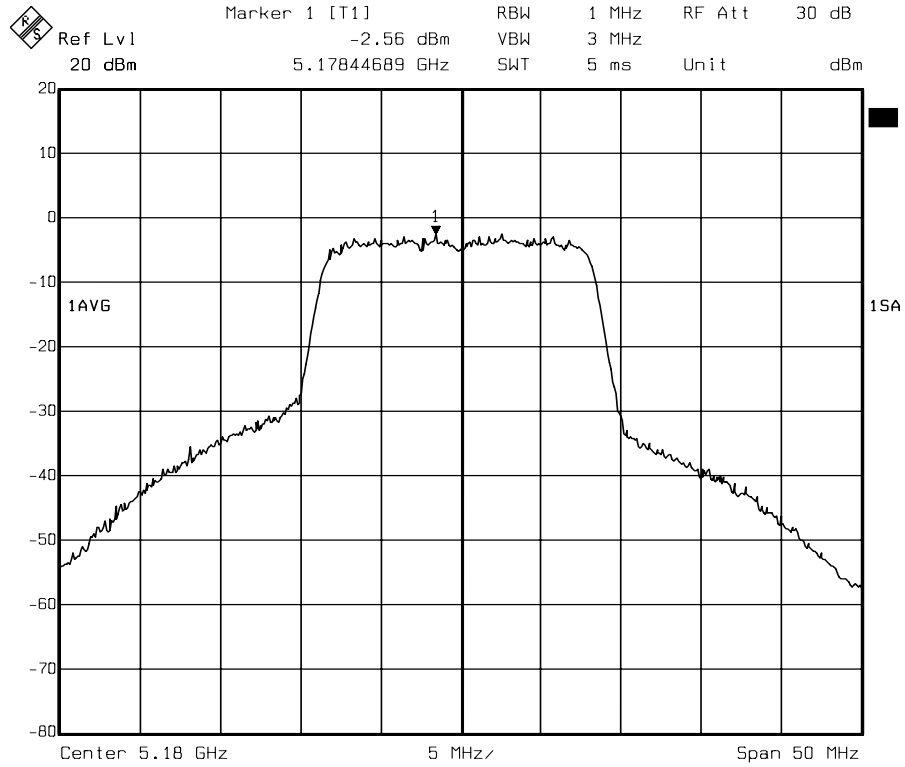

Date: 27.NOV.2004 12:27:10

Channel 1

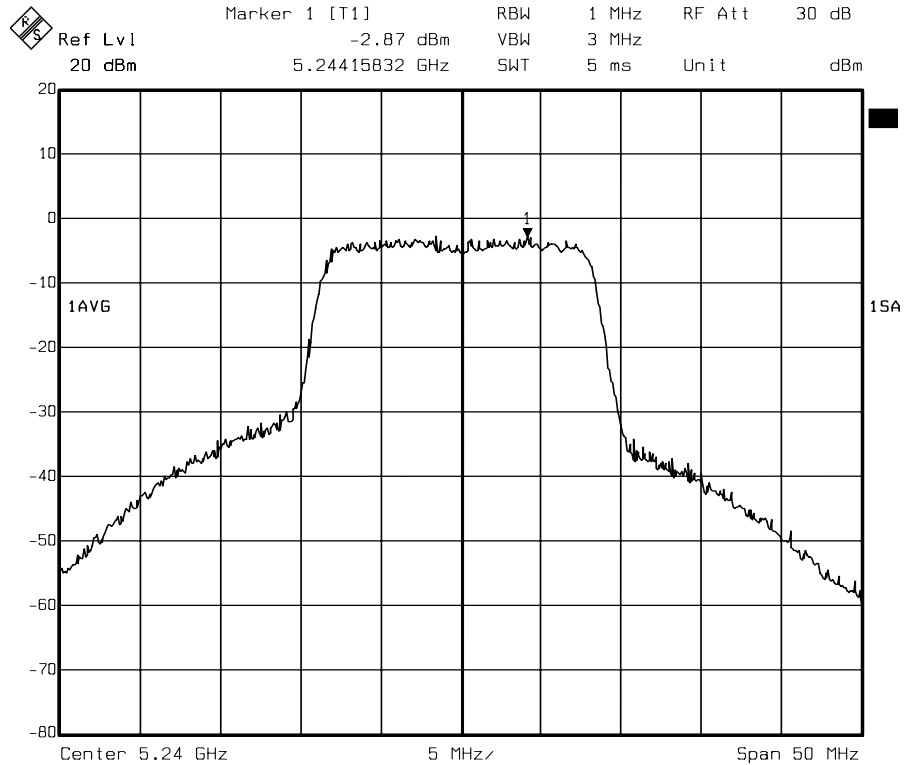

Date: 27.NOV.2004 12:31:53

Channel 4



# Ecom Sertech Corp.

Rm. 258, Bldg. 17, NO.195, Sec.4 Chung Hsing Rd., ChuTugn Chen, Hsinchu, Taiwan 310, R.O.C  
TEL: 886-3-5918012 FAX: 886-3-5825720

FCC ID : PY3WG111U

Report No. : ER04-11-043FRFa

Page 72 of 84

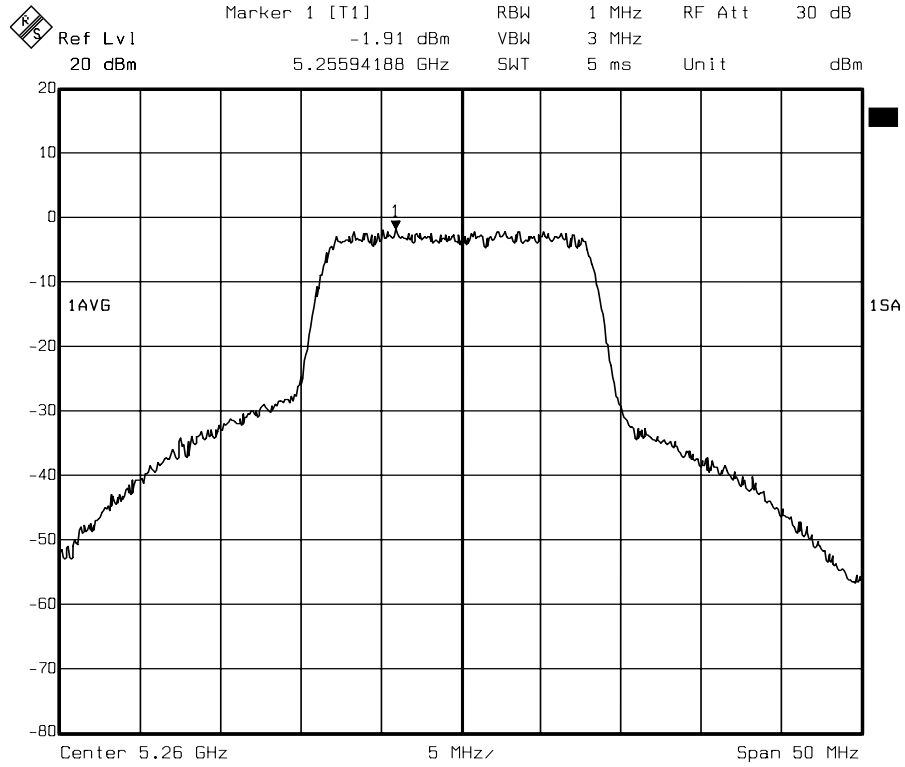

Date: 27.NOV.2004 12:35:32

## Channel 5

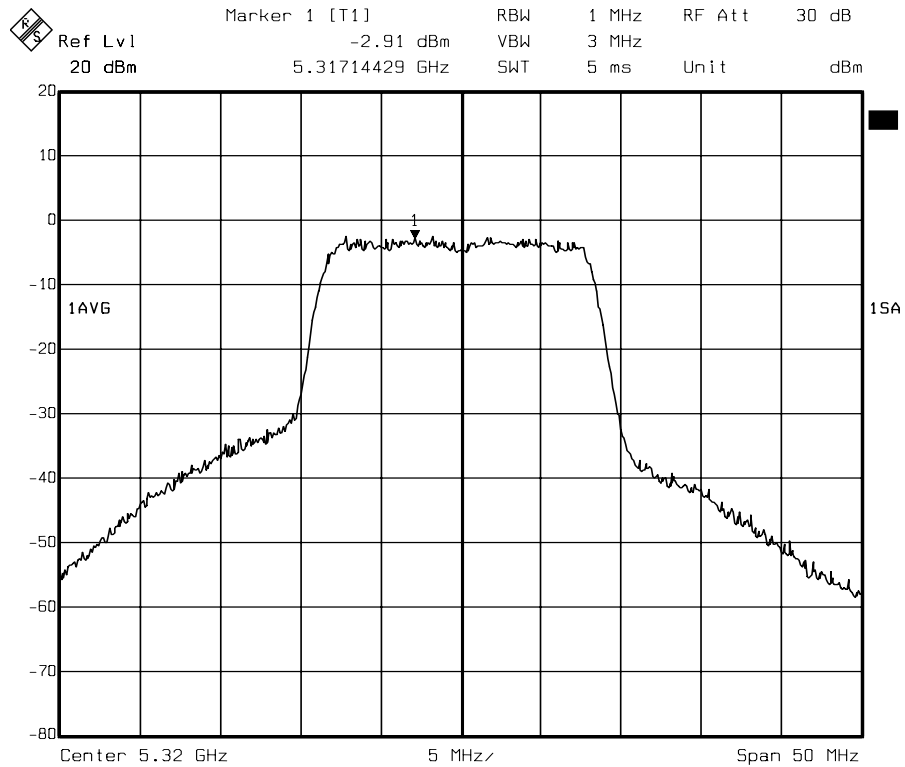

Date: 27.NOV.2004 12:37:02

## Channel 8





# Ecom Sertech Corp.

Rm. 258, Bldg. 17, NO.195, Sec.4 Chung Hsing Rd., ChuTugn Chen, Hsinchu, Taiwan 310, R.O.C  
TEL: 886-3-5918012 FAX: 886-3-5825720

FCC ID : PY3WG111U

Report No. : ER04-11-043FRFa

Page 73 of 84

## For Super A mode

Marker 1 [T1] RBW 1 MHz RF Att 30 dB  
Ref Lvl -3.88 dBm VBW 3 MHz  
20 dBm 5.20549098 GHz SWT 5 ms Unit dBm

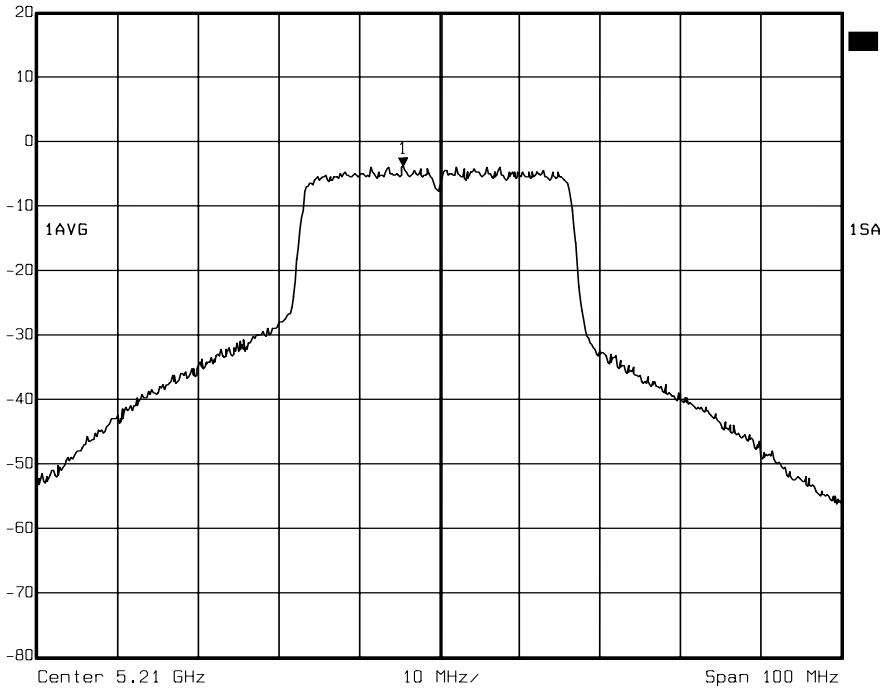

Date: 12.DEC.2004 10:14:28

### Channel Low

Marker 1 [T1] RBW 1 MHz RF Att 30 dB  
Ref Lvl -3.58 dBm VBW 3 MHz  
20 dBm 5.25170341 GHz SWT 5 ms Unit dBm

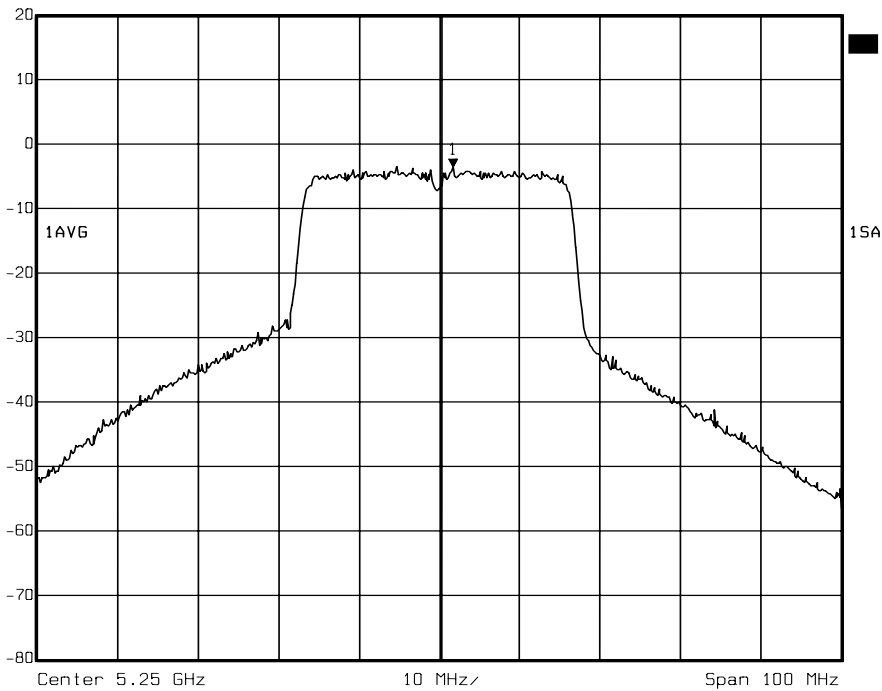

Date: 12.DEC.2004 10:13:44

### Channel Middle



# Ecom Sertech Corp.

Rm. 258, Bldg. 17, NO.195, Sec.4 Chung Hsing Rd., ChuTugn Chen, Hsinchu, Taiwan 310, R.O.C  
TEL: 886-3-5918012 FAX: 886-3-5825720

FCC ID : PY3WG111U

Report No. : ER04-11-043FRFa

Page 74 of 84

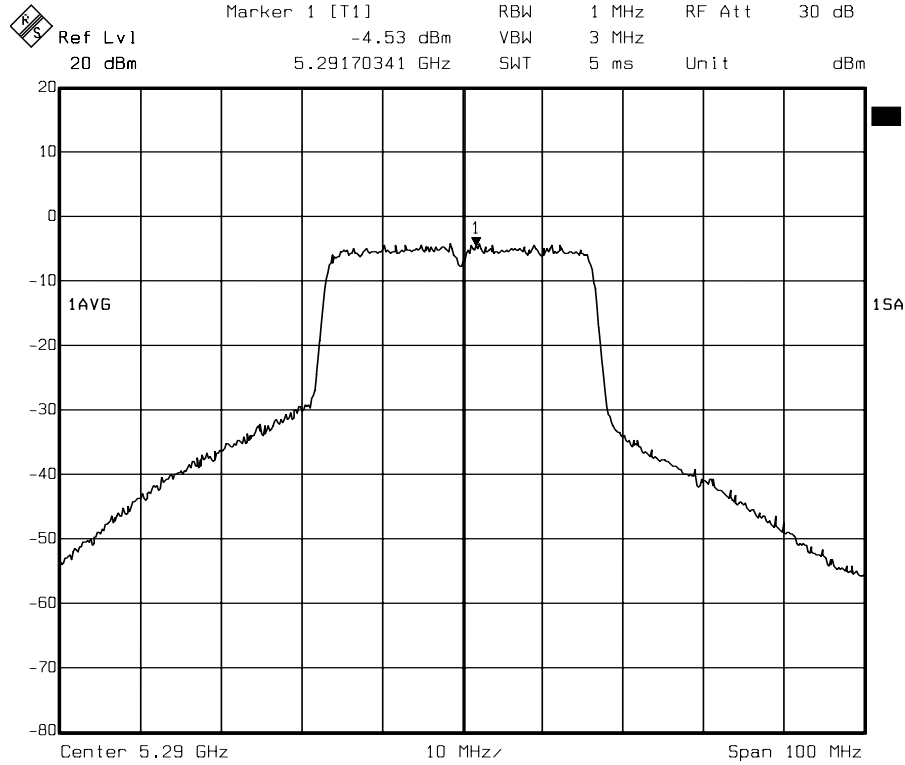

Date: 12.DEC.2004 10:12:56

Channel High



## 7. PEAK POWER EXCURSION MEASUREMENT

### 7.1 Test Equipments

| Description & Manufacturer        | Model No. | Serial No. | Date Of Calibration | Calibration Period |
|-----------------------------------|-----------|------------|---------------------|--------------------|
| ROHDE & SCHWARZ SPECTRUM ANALYZER | FSEK30    | 835253/002 | September 06, 2004  | 1 Year             |

Note :

1. The measurement uncertainty is less than +/- 2.6dB, which is calculated as per the NAMAS document NIS81.
2. The calibration interval of the above test instruments is 12 months and the calibrations are traceable to NML/ROC and NIST/USA.

### 7.2 Test Setup



### 7.3 Limits of Band Edge Emissions Measurement

The largest distance between the two traces described in test procedure must be fewer than 13dB. For all frequencies across the emission bandwidth.

| Channel Frequency Band | (dBm) |
|------------------------|-------|
| 5.15 ~ 5.25GHz Band    | 13 dB |
| 5.25 ~ 5.35GHz Band    | 13dB  |
| 5.47 ~ 5.725GHz Band   | 13 dB |
| 5.725 ~ 5.825GHz Band  | 13 dB |

### 7.4 Test Procedure

- Set the spectrum to view the entire emission bandwidth.
- Measure trace 1:
- Set RBW=1MHz, VBW ≥ 3MHz with peak detector and Max-hold setting.
- Measure trace2:
- Set RBW=1MHz, VBW ≥ 30kHz with peak detector and Max-hold setting
- Plot the result of the two traces and mark the largest distance between the two trace.



## Ecom Sertech Corp.

Rm. 258, Bldg. 17, NO.195, Sec.4 Chung Hsing Rd., ChuTugn Chen, Hsinchu, Taiwan 310, R.O.C  
TEL: 886-3-5918012 FAX: 886-3-5825720

FCC ID : PY3WG111U

Report No. : ER04-11-043FRFa

Page 76 of 84

### 7.5 Uncertainty of Conducted Emission

The uncertainty of conducted emission is  $\pm 1.82$ dB.

### 7.6 Test Results

|                     |   |                            |             |
|---------------------|---|----------------------------|-------------|
| <b>Company</b>      | Netgear Incorporated                            | <b>Test Date</b>           | 2004/12/13  |
| <b>Product Name</b> | Double 108 Mbps Wireless USB 2.0 Adapter WG111U | <b>Test By</b>             | Alan Fan    |
| <b>Model Name</b>   | WG111U  | <b>TEMP &amp; Humidity</b> | 21.1°C, 63% |

In 5.15 ~ 5.35GHz Band  
For normal 802.11a mode

| Channel | Channel Frequency (MHz) | Largest distance between trace 1 and trace 2 (dB) | FCC Peak Excursion Limit (dBm) | Pass / Fail |
|---------|-------------------------|---|--------------------------------|-------------|
| 1       | 5180                    | 9.04  | < 13                           | PASS        |
| 4       | 5240                    | 9.53  | < 13                           | PASS        |
| 5       | 5260                    | 9.35  | < 13                           | PASS        |
| 8       | 5320                    | 9.58  | < 13                           | PASS        |

For Super A mode

| Channel | Channel Frequency (MHz) | Largest distance between trace 1 and trace 2 (dB) | FCC Peak Excursion Limit (dBm) | Pass / Fail |
|---------|-------------------------|---|--------------------------------|-------------|
| Low     | 5210                    | 9.66  | < 13                           | PASS        |
| Middle  | 5250                    | 9.69  | < 13                           | PASS        |
| High    | 5290                    | 9.46  | < 13                           | PASS        |



### 7.7 Photo of Peak Power Excursion Measurement

In 5.15 ~ 5.35 GHz Band  
For normal 802.11a mode

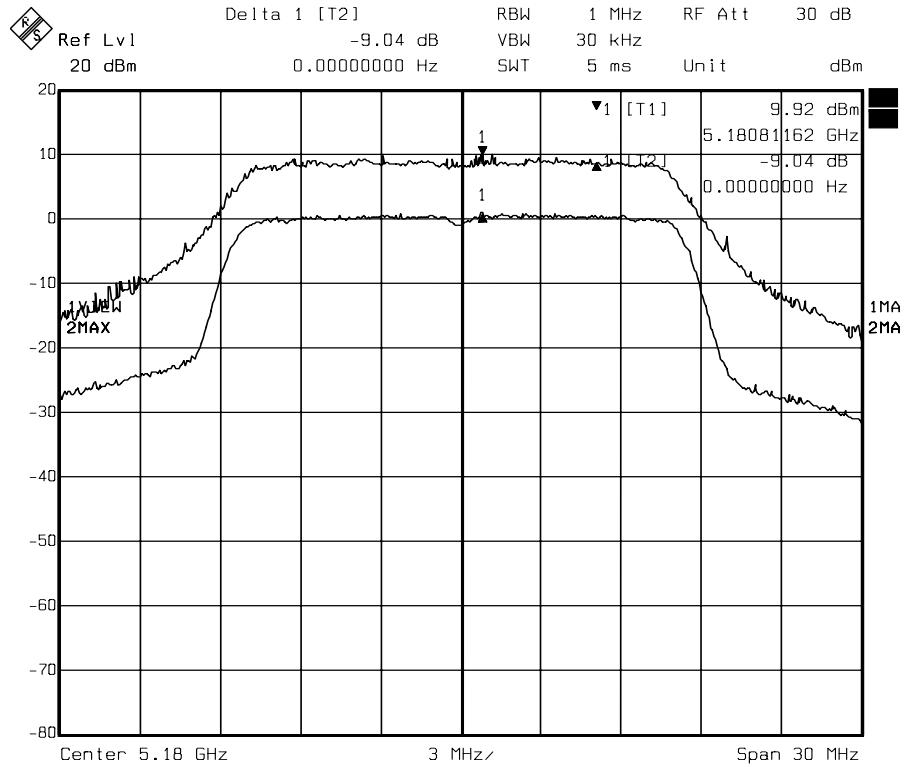

Channel 1

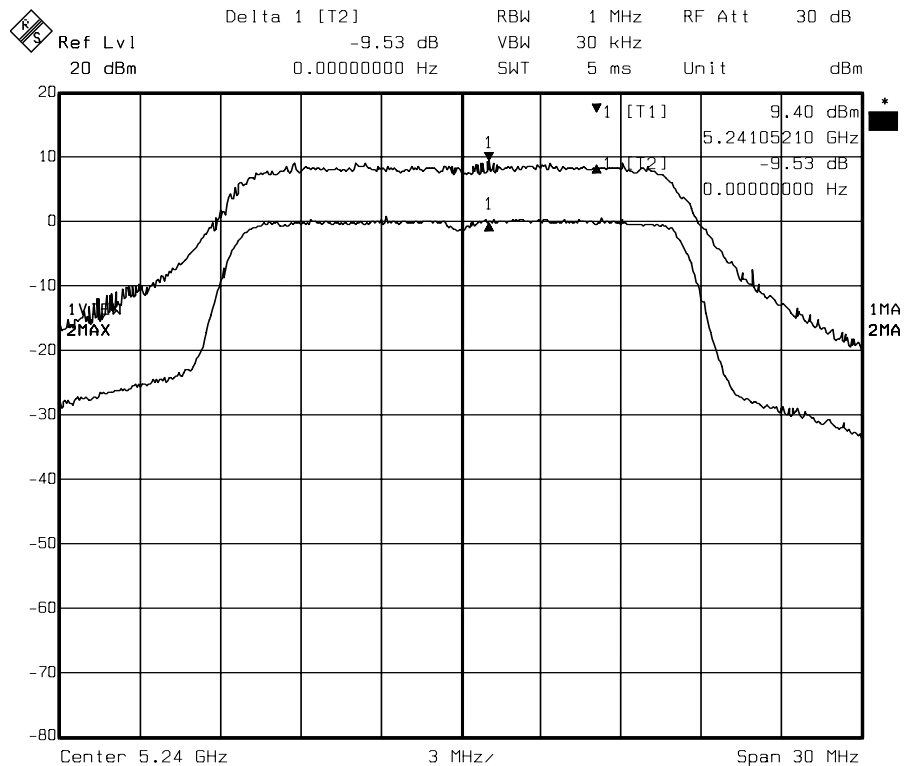

Channel 4



**Ecom Sertech Corp.**

Rm. 258, Bldg. 17, NO.195, Sec.4 Chung Hsing Rd., ChuTugn Chen, Hsinchu, Taiwan 310, R.O.C  
 TEL: 886-3-5918012 FAX: 886-3-5825720

FCC ID : PY3WG111U

Report No. : ER04-11-043FRFa

Page 78 of 84

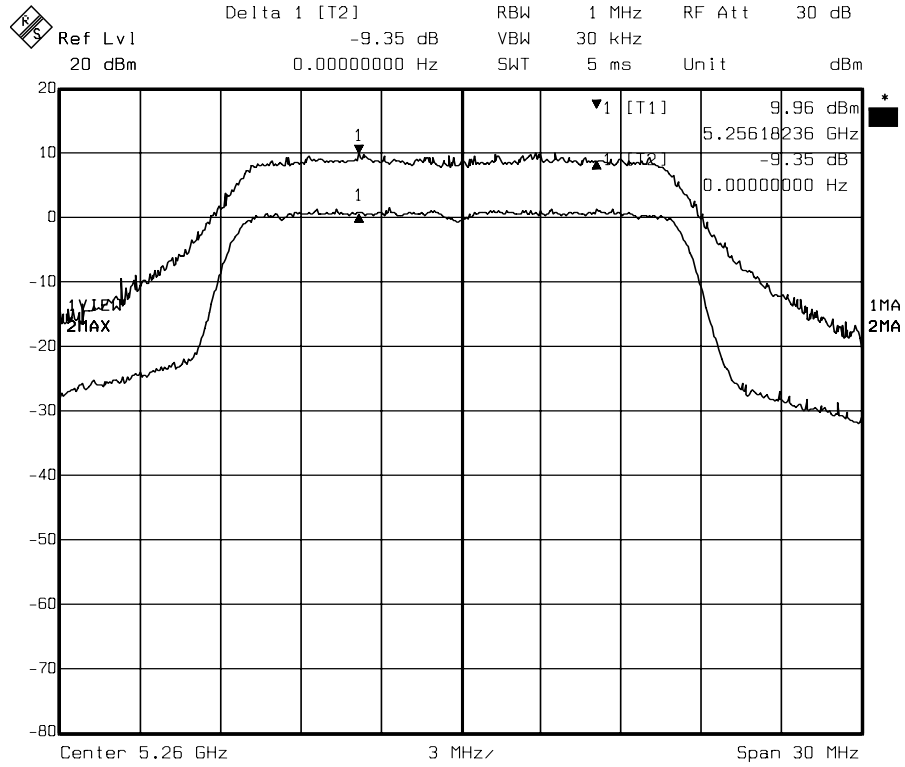

Date: 27.NOV.2004 13:10:18

**Channel 5**

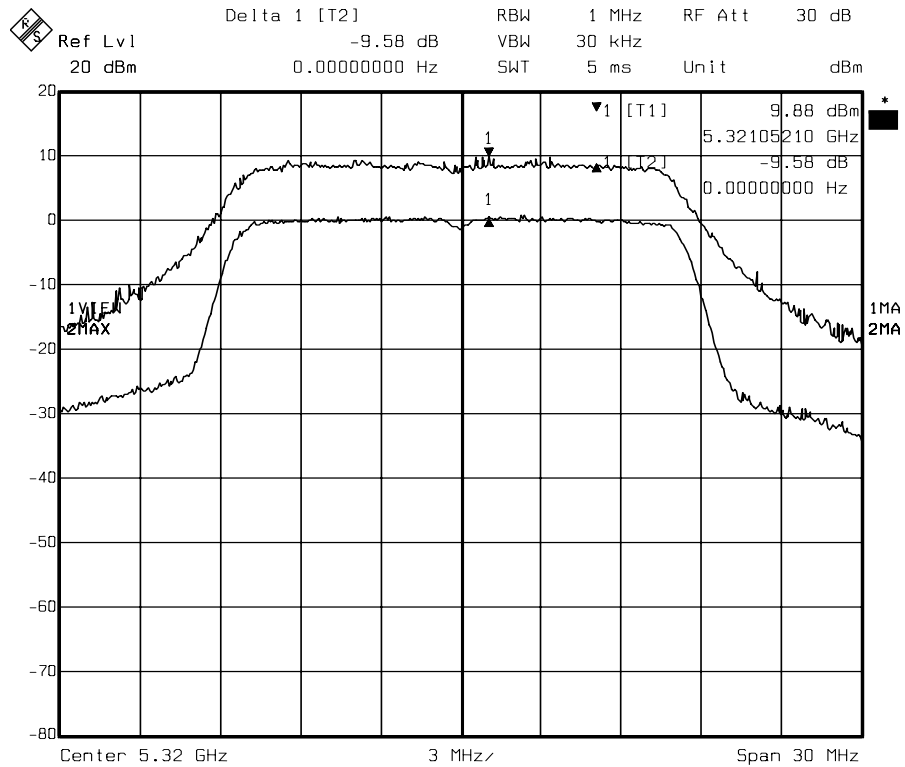

Date: 27.NOV.2004 13:06:57

**Channel 8**



For Super A mode

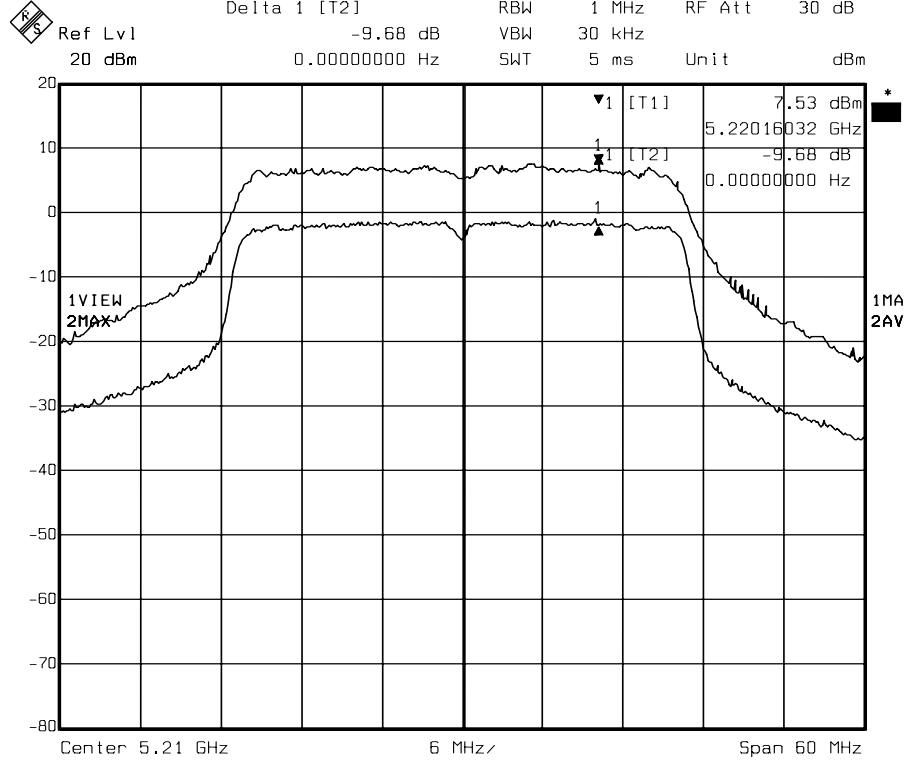

Date: 12.DEC.2004 10:32:04

Channel Low

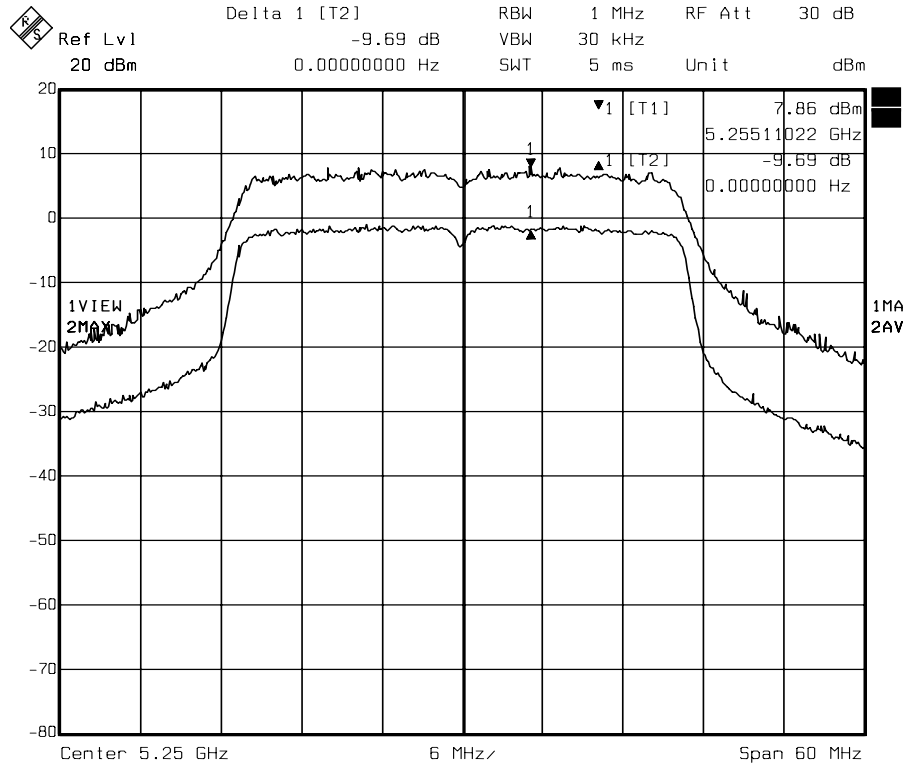

Date: 12.DEC.2004 10:35:01

Channel Middle



# Ecom Sertech Corp.

Rm. 258, Bldg. 17, NO.195, Sec.4 Chung Hsing Rd., ChuTugn Chen, Hsinchu, Taiwan 310, R.O.C  
TEL: 886-3-5918012 FAX: 886-3-5825720

FCC ID : PY3WG111U

Report No. : ER04-11-043FRFa

Page 80 of 84

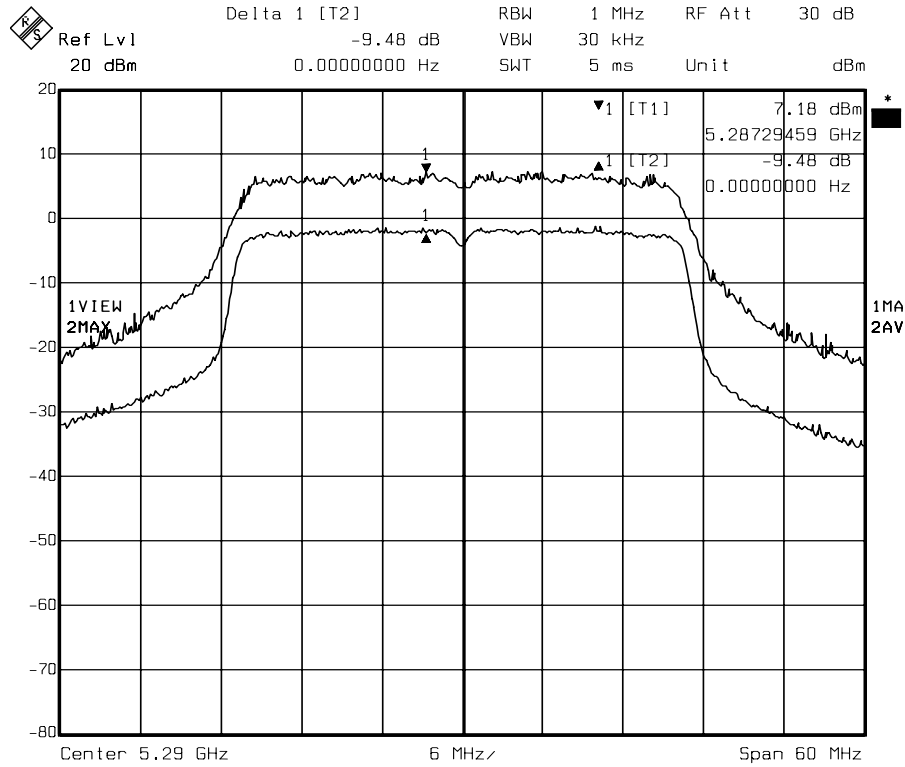

Date: 12.DEC.2004 10:38:28

Channel High



## 8. REQUIREMENT STABILITY

### 8.1 Standard Applicable

| Description & Manufacturer | Model No. | Serial No. | Date Of Calibration | Calibration Period |
|----------------------------|-----------|------------|---------------------|--------------------|
| HP SPECTRUM ANALYZER       | 8595E     | 3829U01362 | July 30, 2004       | 1 Year             |

Note :

1. The measurement uncertainty is less than +/- 2.6dB, which is calculated as per the NAMAS document NIS81.
2. The calibration interval of the above test instruments is 12 months and the calibrations are traceable to NML/ROC and NIST/USA.

### 8.2 Test Setup

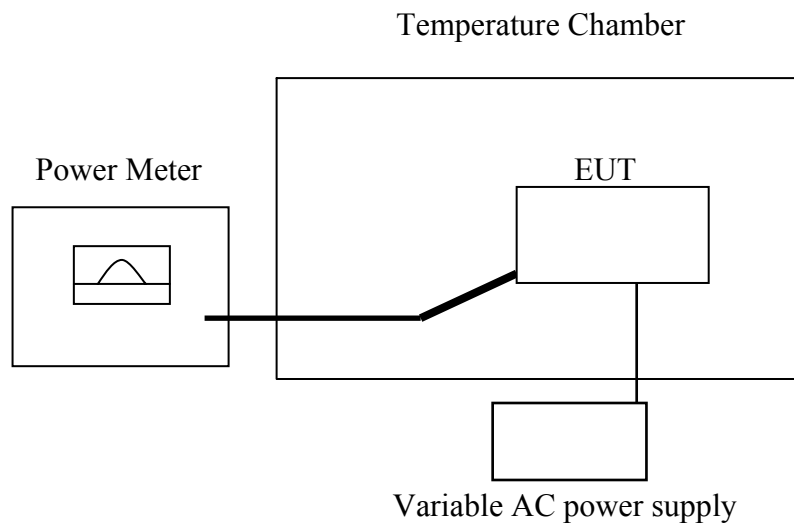

### 8.3 Limits of Out of Band Emissions Measurement

The frequency tolerance of the carrier signal shall be maintained within +/- 20ppm of the operating frequency over a temperature variation of 0 to 50 °C at normal supply voltage, and for a variation in the primary supply voltage from 85% to 115% of the rated supply voltage at a temperature of 25 °C at normal.



## **8.4 Test Procedure**

1. The EUT was placed inside a temperature test chamber and powered by AC voltage supply.
2. Turn the EUT on and connect the RF output port to a spectrum analyzer.
3. Set the temperature in chamber to the declared highest temperature.
4. Wait approximately 30 min to make sure the temperature of the chamber is stabilized.
5. Measure and record the center frequency of carrier at 85% to 115% nominal supplied voltage.
6. Repeat step 4 and 5 with the temperature of chamber is set to the normal temperature, 25°C.
7. Repeat step 4 and 5 with the temperature of chamber is set to the lowest temperature.

## **8.5 Uncertainty of Conducted Emission**

The uncertainty of conducted emission is  $\pm 1.82\text{dB}$ .



**8.6 Test Results**

| TEST CONDITIONS          |                           | Operating Frequency (MHz) 5180MHz |                            |             |             |
|--------------------------|---------------------------|-----------------------------------|----------------------------|-------------|-------------|
|                          |                           | Measured Frequency (MHz)          | Frequency Difference (KHz) | Limit (KHz) | Test Result |
| T <sub>min</sub> ( 0°C)  | V <sub>min</sub> ( 102 )V | 5180.02806                        | 28.0600                    | ±103.6      | PASS        |
|                          | V <sub>nom</sub> ( 120 )V | 5180.02806                        | 28.0600                    | ±103.6      | PASS        |
|                          | V <sub>max</sub> ( 138 )V | 5180.02806                        | 28.0600                    | ±103.6      | PASS        |
| T <sub>nom</sub> ( 25°C) | V <sub>min</sub> ( 102 )V | 5179.93186                        | -68.1400                   | ±103.6      | PASS        |
|                          | V <sub>nom</sub> ( 120 )V | 5179.93988                        | -60.1200                   | ±103.6      | PASS        |
|                          | V <sub>max</sub> ( 138 )V | 5179.93186                        | -68.1400                   | ±103.6      | PASS        |
| T <sub>max</sub> ( 50°C) | V <sub>min</sub> ( 102 )V | 5179.93988                        | -60.1200                   | ±103.6      | PASS        |
|                          | V <sub>nom</sub> ( 120 )V | 5179.91583                        | -84.1700                   | ±103.6      | PASS        |
|                          | V <sub>max</sub> ( 138 )V | 5179.93988                        | -60.1200                   | ±103.6      | PASS        |

| TEST CONDITIONS          |                           | Operating Frequency (MHz) 5320MHz |                            |             |             |
|--------------------------|---------------------------|-----------------------------------|----------------------------|-------------|-------------|
|                          |                           | Measured Frequency (MHz)          | Frequency Difference (KHz) | Limit (KHz) | Test Result |
| T <sub>min</sub> ( 0°C)  | V <sub>min</sub> ( 102 )V | 5320.03607                        | 36.0700                    | ±106.4      | PASS        |
|                          | V <sub>nom</sub> ( 120 )V | 5320.02004                        | 20.0400                    | ±106.4      | PASS        |
|                          | V <sub>max</sub> ( 138 )V | 5320.03607                        | 36.0700                    | ±106.4      | PASS        |
| T <sub>nom</sub> ( 25°C) | V <sub>min</sub> ( 102 )V | 5319.96393                        | -36.0700                   | ±106.4      | PASS        |
|                          | V <sub>nom</sub> ( 120 )V | 5319.96393                        | -36.0700                   | ±106.4      | PASS        |
|                          | V <sub>max</sub> ( 138 )V | 5319.96393                        | -36.0700                   | ±106.4      | PASS        |
| T <sub>max</sub> ( 50°C) | V <sub>min</sub> ( 102 )V | 5319.93186                        | -68.1400                   | ±106.4      | PASS        |
|                          | V <sub>nom</sub> ( 120 )V | 5319.93988                        | -60.1200                   | ±106.4      | PASS        |
|                          | V <sub>max</sub> ( 138 )V | 5319.95591                        | -44.0900                   | ±106.4      | PASS        |



---

## 9. ANTENNA REQUIREMENT

### 9.1 Standard Applicable

For intentional device, according to FCC 47 CFR Section 15.203, an intentional radiator shall be designed to ensure that no antenna other than that furnished by the responsible party shall be used with the device.

And according to FCC 47 CFR Section 15.407 (d), Any U-NII device that operates in the 5.15 ~ 5.25GHz band shall use a transmitting antenna that is an integral part of the device. If transmitting antennas of directional gain greater than 6 dBi are used, both the peak transmit power and the peak power spectral density shall be reduced by the amount in dB that the directional gain of the antenna exceeds 6 dBi.

For 5.25 ~ 5.35GHz and 5.47 ~ 5.725GHz, if transmitting antennas of directional gain greater than 6 dBi are used, both the peak transmit power and the peak power spectral density shall be reduced by the amount in dB that the directional gain of the antenna exceeds 6 dBi.

For 5.725 ~ 5.825GHz band, if transmitting antennas of directional gain greater than 6 dBi are used, both the peak transmit power and the peak power spectral density shall be reduced by the amount in dB that the directional gain of the antenna exceeds 6 dBi. However, fixed point-to-point U-NII devices operating in this band may employ transmitting antennas with directional gain up to 23 dBi without any corresponding reduction in the transmitter peak output power or peak power spectral density. For fixed, point-to-point U-NII transmitters that employ a directional antenna gain greater than 23 dBi, a 1 dB reduction in peak transmitter power and peak power spectral density for each 1 dB of antenna gain in excess of 23 dBi would be required.

### 9.2 Antenna Connected Construction

The antenna used for this product is Patch antenna . The antenna is soldered on PCB and the peak Gain of this antenna is only 3.73dBi at 5GHz, -0.09dBi at 2.4GHz.