

FCC TEST REPORT

for

47 CFR, Part 15, Subpart C

Equipment : Cable/DSL Wireless Router with 4 port 10/100 Mbps switch

Model No. : MR814

FCC ID : PY3MR814V2

Filing Type : Certification

Applicant : **NETGEAR Inc.**
4500 Great America Parkway, Santa Clara, CA 95054,
U.S.A.

- The test result refers exclusively to the test presented test model / sample.
- Without written approval of SPORTON International Inc., the test report shall not be reproduced except in full.
- **Certificate or Test Report must not be used by the applicant to claim the product in this test report endorsement by NVLAP or any agency of U.S. government.**

SPORTON International Inc.

6F, No.106, Sec. 1, Hsin Tai Wu Rd., Hsi Chih, Taipei Hsien, Taiwan, R.O.C.

SPORTON International Inc.

TEL : 886-2-2696-2468

FAX : 886-2-2696-2255

Table of Contents

History of this test report	ii
CERTIFICATE OF COMPLIANCE.....	1
1. General Description of Equipment under Test.....	2
1.1. Applicant.....	2
1.2. Manufacturer	2
1.3. Basic Description of Equipment under Test	2
1.4. Feature of Equipment under Test	3
2. Test Configuration of Equipment under Test.....	4
2.1. Test Manner	4
2.2. Description of Test System	4
2.3. Connection Diagram of Test System	6
3. Operation of Equipment under Test	7
4. General Information of Test.....	8
4.1. Test Voltage	8
4.2. Standard for Methods of Measurement.....	8
4.3. Test in Compliance with	8
4.4. Frequency Range Investigated	8
4.5. Test Distance	8
5. Report of Measurements and Examinations	9
5.1. List of Measurements and Examinations	9
5.2. 6dB Bandwidth	10
5.3. Peak Output Power	14
5.4. Power Spectral Density	15
5.5. Test of Conducted Emission	19
5.6. Test of Radiated Emission	23
5.7. Band Edges Measurement.....	32
5.8. Antenna Requirements	35
5.9. RF Exposure	36
6. EMI Suppression Component List.....	38
7. Antenna Factor & Cable Loss	39
8. List of Measuring Equipments Used	41
9. Uncertainty of Test Site	42

CERTIFICATE OF COMPLIANCE

for

47 CFR, Part 15, Subpart C

Equipment : Cable/DSL Wireless Router with 4 port 10/100 Mbps switch

Model No. : MR814

FCC ID : PY3MR814V2

Filing Type : Certification

Applicant : **NETGEAR Inc.**
4500 Great America Parkway, Santa Clara, CA 95054,
U.S.A.

I **HEREBY** CERTIFY THAT :

The measurements shown in this test report were made in accordance with the procedures given in **ANSI C63.4 - 1992** and the equipment under test was **passed** all test items required in FCC Part 15 subpart C, relative to the equipment under test. Testing was carried out on Jan. 17, 2003 at **SPORTON International Inc.** LAB.

K. J. Lin Mar. 10, 2003

K. J. Lin
Manager

SPORTON International Inc.

6F, No.106, Sec. 1, Hsin Tai Wu Rd., Hsi Chih, Taipei Hsien, Taiwan, R.O.C.

1. General Description of Equipment under Test

1.1. Applicant

NETGEAR Inc.
4500 Great America Parkway, Santa Clara, CA 95054, U.S.A.

1.2. Manufacturer

Same as 1.1

1.3. Basic Description of Equipment under Test

Equipment	: Cable/DSL Wireless Router with 4 port 10/100 Mbps switch
Model No.	: MR814
FCC ID	: PY3MR814V2
Trade Name	: NETGEAR
TP Cable	: Shielded, 1.8m
TP Cable	: Non-Shielded, 3m
Power Supply Type	: Linear
AC Power Input	: Wall-Mount, 2pin
DC Power Cable	: Non-Shielded, 1.8m

1.4. Feature of Equipment under Test

Product Feature & Specification				
1. Host/Radio Interface	DSSS			
2. Type of Modulation	CCK, DBPSK, DQPSK			
3. Number of Channels	USA/Canada: 11	V	European: 13	V
	Japan: 13, 14		Other:	
4. Frequency Band	2400MHz~2483.5MHz			
5. Carrier Frequency of each channel	2412MHz+(n-1)5MHz, n=Channel NO.			
6. Bandwidth of each channel	11 MHz			
7. Antenna of Maximum Output Power	Typical Transmit Power: 20 dBm			
8. IF & L.O. frequency	IF: 374 MHz, L.O.: 2038~2098MHz			
9. Type of Antenna Connector	Undetachable			
10. Type of Antenna	1/4 Dipole			
11. Antenna Gain (Peak)	2 dBi			
12. Function Type	Transmitter		Transceiver	V
13. Power Rating (DC/AC , Voltage)	Input : AC 100V~240V, Output : DC 7.5 V@ 1A			
14. Duty Cycle	100% (During the test)			
15. Basic function of product	Wireless router			
16. Temperature Range (Operating)	0 ~40			
17. Humidity	10%~90%			

2. Test Configuration of Equipment under Test

2.1. Test Manner

- a. The EUT has been associated with personal computer and peripherals pursuant to ANSI C63.4-1992 and configuration operated in a manner, which tended to maximize its emission characteristics in a typical application.
- b. The complete test system included remote workstation, HP PC, REALsync Monitor, LOGITECH PS/2 Keyboard, LOGITECH PS/2 Mouse, HP Printer, ACEEX Modem and EUT for EMI test. The remote workstation included HP PC, REALsync Monitor, LOGITECH PS/2 Keyboard and LOGITECH PS/2 Mouse.
- c. The EUT can operate on eleven channels from 2412.0MHz to 2462.0MHz. (as listed in section 1.4). According to 15.31(m), three channels (one near top, one near middle and one near bottom) were performed as following:
Mode 1: 2412MHz (Channel 1)
Mode 2: 2437MHz (Channel 6)
Mode 3: 2462MHz (Channel 11)
- d. Frequency range investigated: conduction 150 KHz to 30 MHz, radiation 30 MHz to 25000MHz.

2.2. Description of Test System

Support Unit 1. -- Personal Computer (HP) – for local and remote workstation

FCC ID	: N/A
Model No.	: VECTRAC VL420 DT
Power Supply Type	: Switching
Power Cord	: Non-Shielded
Serial No.	: SP0037
Remark	: This support device was tested to comply with FCC standards and authorized under a declaration of conformity.

Support Unit 2. -- Monitor (REALsync) – for local and remote workstation

FCC ID	: N/A
Model No.	: DJ72
Power Supply Type	: Switching
Power Cord	: Non-Shielded
Serial No.	: SP0051
Data Cable	: Shielded, 1.7m
Remark	: This support device was tested to comply with FCC standards and authorized under a declaration of conformity.

Support Unit 3. -- PS/2 Keyboard (LOGITECH) – for local and remote workstation

FCC ID : N/A
Model No. : Y-SJ17
Serial No. : SP0054
Data Cable : Shielded, 360 degree via metal backshells, 1.7m
Remark : This support device was tested to comply with FCC standards and authorized under a declaration of conformity.

Support Unit 4. – PS/2 Mouse (LOGITECH) – for local and remote workstation

FCC ID : DZL211029
Model No. : M-S34
Serial No. : SP0041
Data Cable : Shielded, 1.7m

Support Unit 5. -- Printer (HP) – for local workstation

FCC ID : B94C2642X
Model No. : DJ 400
Power Supply Type : Linear
Power Cord : Non-Shielded
Serial No. : SP0048
Data Cable : Shielded, 360 degree via metal backshells, 1.35m

Support Unit 6. -- Modem (ACEEX) – for local workstation

FCC ID : IFAXDM1414
Model No. : DM1414
Power Supply Type : Linear
Power Cord : Non-Shielded
Serial No. : SP0015
Data Cable : Shielded, 1.15m

2.3. Connection Diagram of Test System

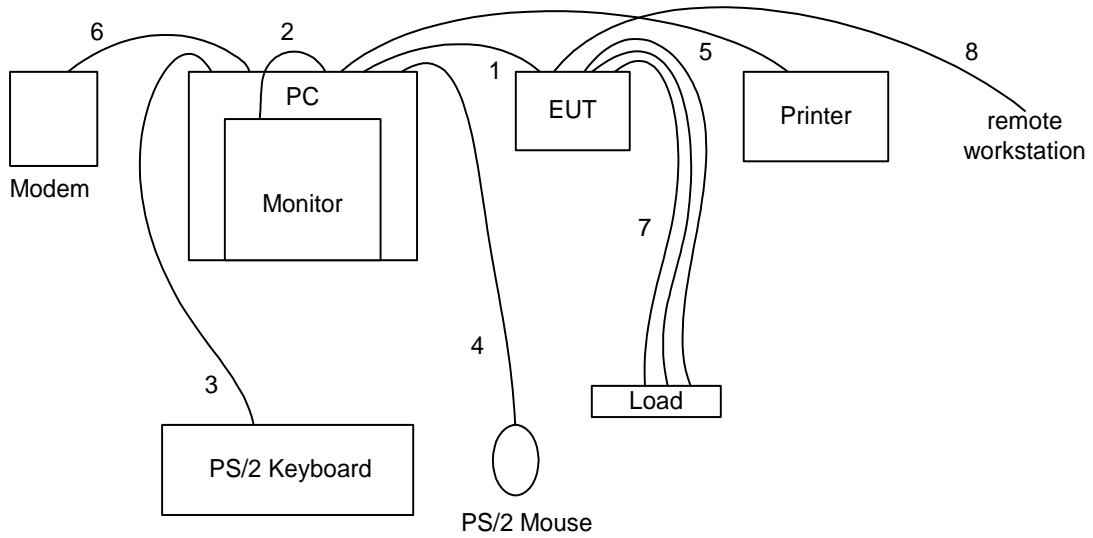

- 1. The TP cable is connected from PC to the EUT
- 2. The I/O cable is connected from PC to the support unit 2
- 3. The I/O cable is connected from PC to the support unit 3.
- 4. The I/O cable is connected from PC to the support unit 4
- 5. The I/O cable is connected from PC to the support unit 5
- 6. The I/O cable is connected from PC to the support unit 6
- 7. These are loop-back TP cables.
- 8. The TP cable is connected from EUT to the remote workstation.

3. Operation of Equipment under Test

An executive program, EMCTEST.EXE under WIN 2000, which generates a complete line of continuously repeating " H" pattern was used as the test software.

The program was executed as follows:

- a. Turn on the power of all equipment.
- b. The PC reads the test program from the hard disk drive and runs it.
- c. The PC sends " H" messages to the monitor, and the monitor displays " H" patterns on the screen.
- d. The PC sends " H" messages to the printer, then the printer prints them on the paper.
- e. The PC sends " H" messages to the internal Hard Disk, and the Hard Disk reads and writes the message.
- f. Repeat the steps from c to e.

At the same time, "Winft" was executed to keep transmitting signals at fixed frequency.

4. General Information of Test

Test Site Location : No. 52, Hwa Ya 1st Rd., Hwa Ya Technology Park,
Kwei-Shan Hsiag, Tao Yuan Hsien, Taiwan, R.O.C.
TEL : 886-3-327-3456
FAX : 886-3-318-0055
Test Site No : CO01-HY, 03CH03-HY

4.1. Test Voltage

115V/60Hz

4.2. Standard for Methods of Measurement

ANSI C63.4-1992

4.3. Test in Compliance with

FCC Part 15, Subpart C

4.4. Frequency Range Investigated

- a. Conduction: from 150 KHz to 30 MHz
- b. Radiation: from 30 MHz to 25000MHz

4.5. Test Distance

The test distance of radiated emission from antenna to EUT is 3 M.

5. Report of Measurements and Examinations

5.1. List of Measurements and Examinations

FCC Rule	Description of Test	Result
15.207	Conducted Emission	Pass
<u>15.247(a)(2)</u>	6dB Bandwidth	Pass
<u>15.247(b)</u>	Maximum Peak Output Power	Pass
15.209	Radiated Emission	Pass
<u>15.247(c)</u>	100kHz Bandwidth of Frequency Band Edges	Pass
<u>15.247(d)</u>	Power Spectral Density	Pass
<u>15.203</u>	Antenna Requirement	Pass
1.1307 1.1310 2.1091 2.1093	RF Exposure Compliance	Pass

5.2. 6dB Bandwidth

5.2.1. Measuring Instruments :

As described in chapter 6 of this test report.

5.2.2. Test Procedure :

1. The transmitter output was connected to the spectrum analyzer through an attenuator.
2. Set RBW of spectrum analyzer to 100KHz and VBW to 100KHz.
3. The 6 dB bandwidth is defined as the total spectrum the power of which is higher than peak power minus 6 dB.

5.2.3. Test Setup Layout :

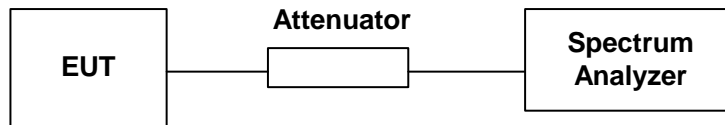

5.2.4. Test Result : The spectrum analyzer plots are attached as below

- Temperature : 21°C
- Relative Humidity : 60.5 %

Channel	Frequency (MHz)	6dB Emission bandwidth (MHz)	Limits (MHz)	Plot Ref. No.
1	2412	8.760	0.5	1
6	2437	8.840	0.5	2
11	2462	8.200	0.5	3

Plot1(Channel 1) :

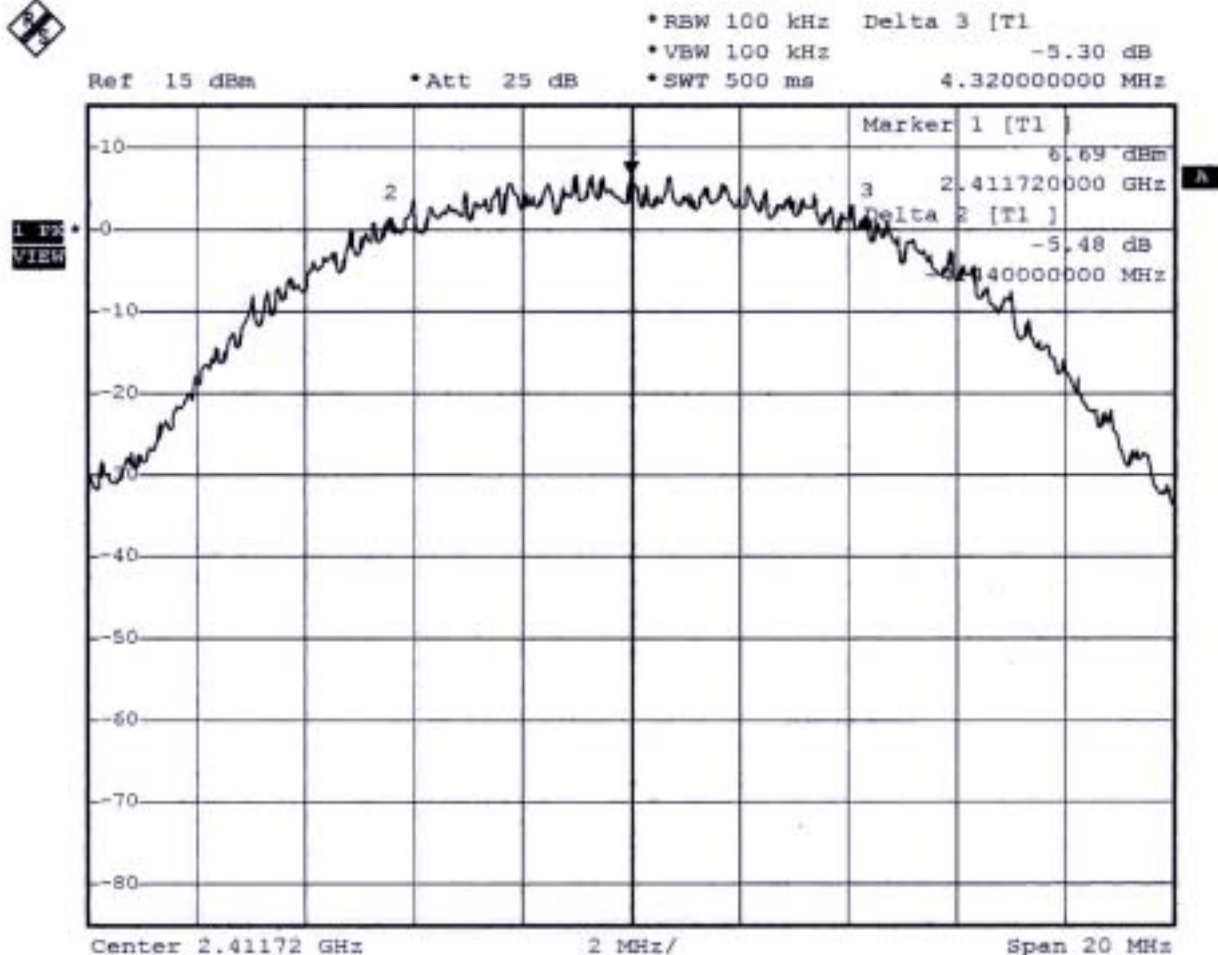

Date: 15.JAN.2003 22:07:43

Plot2(Channel 6) :

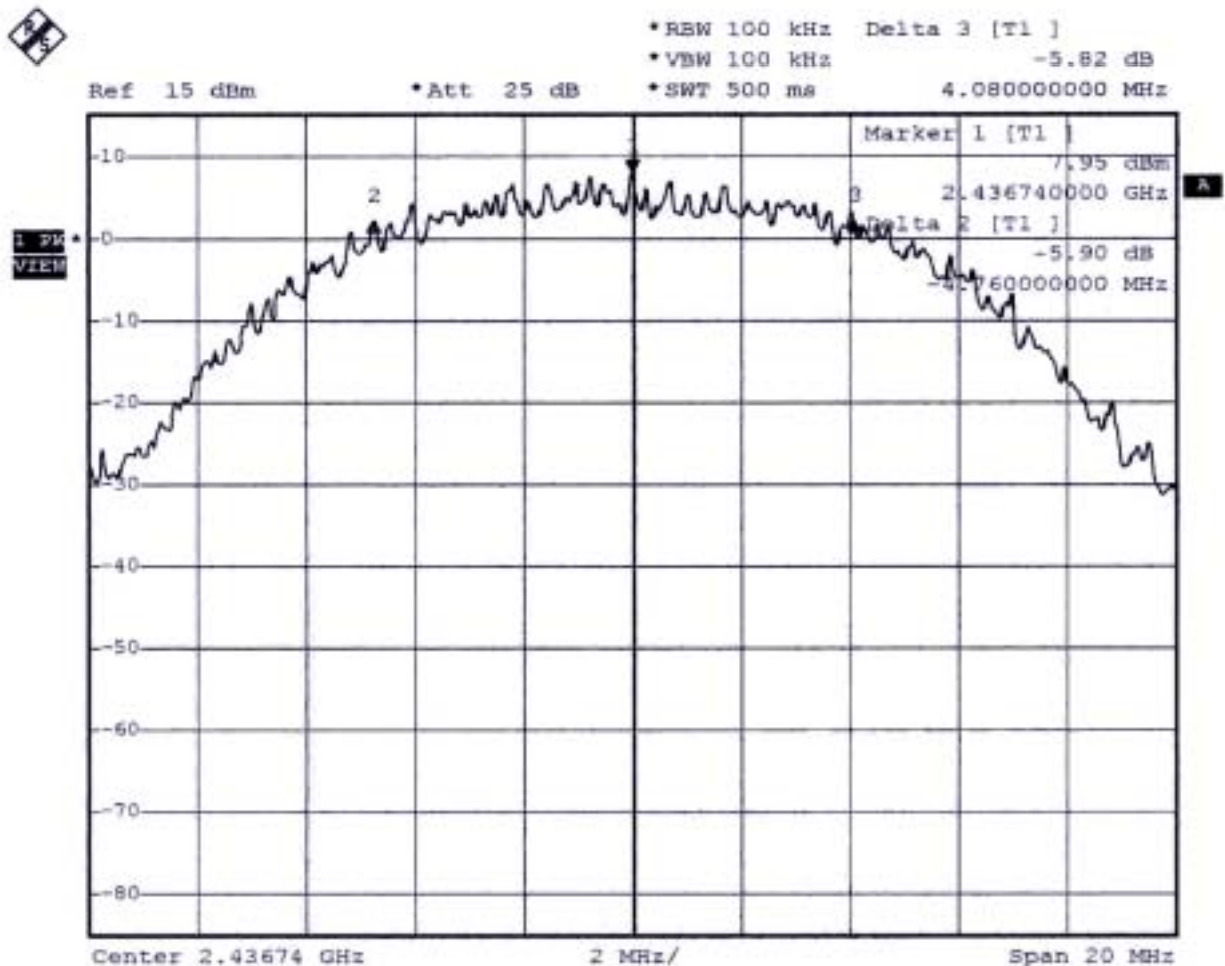

Date: 15.JAN.2003 22:14:56

Plot3(Channel 11) :

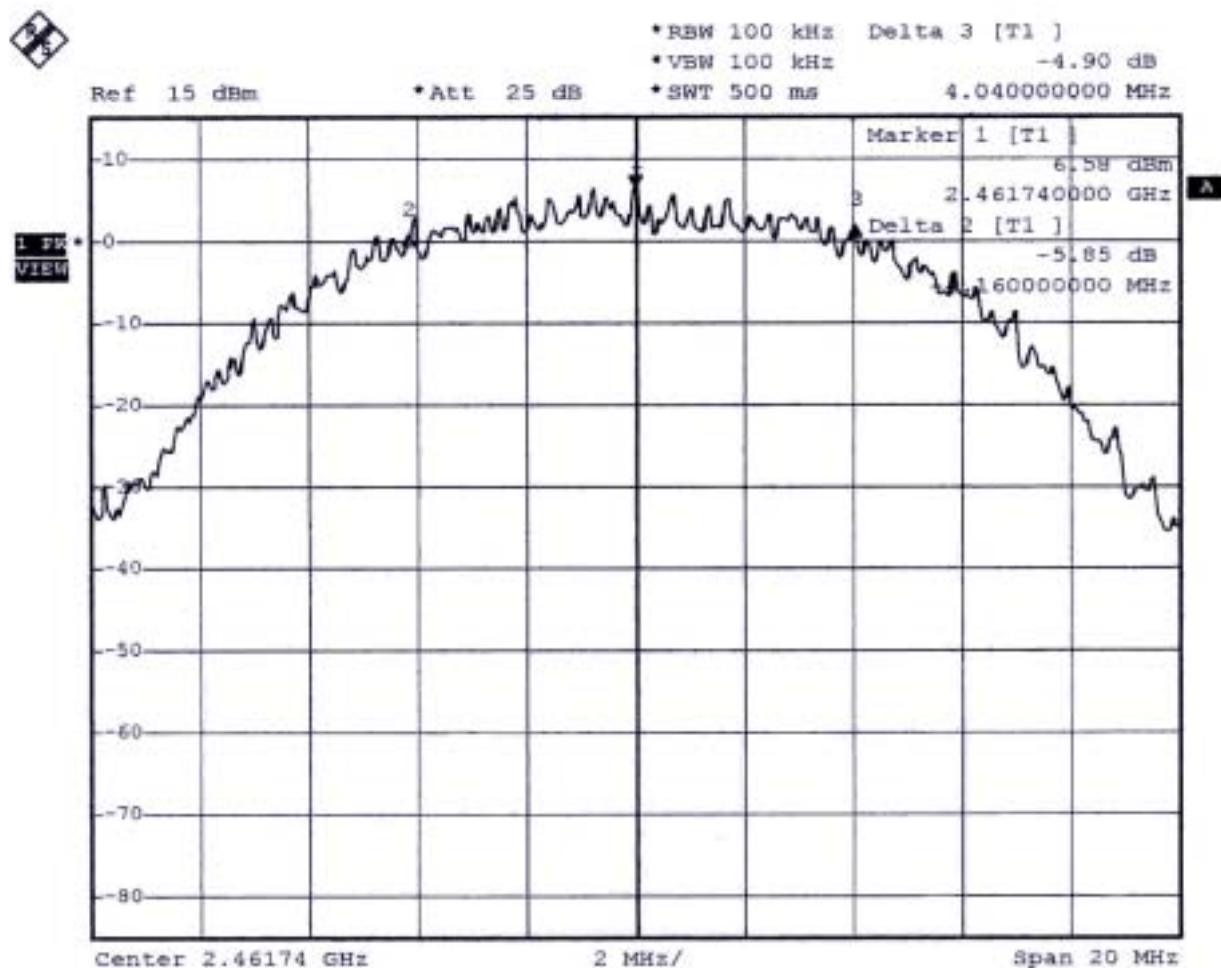

Date: 15.JAN.2003 22:18:57

Comments : 6dB Emission bandwidth>500kHz

5.3. Peak Output Power

5.3.1. Measuring Instruments :

As described in chapter 6 of this test report.

5.3.2. Test Procedure :

The antenna port (RF output) of the EUT was connected to the input (RF input) of a power meter. Power was read directly from the meter and cable loss connection was added to the reading to obtain power at the EUT antenna terminal. The EUT Output Power was set to maximum to produce the worse case test result.

5.3.3. Test Setup Layout :

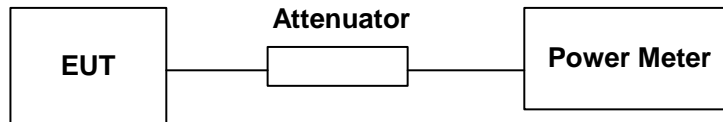

5.3.4. Test Result : See spectrum analyzer plots below

- Temperature : 21°C
- Relative Humidity : 60.5 %
- Antenna Gain: 2 dBi

Channel	Frequency (MHz)	Measured Output Power (mWatt)	Measured Output Power (dBm)	Limits (Watt/dBm)
1	2412	207.49	23.17	1W/30 dBm
6	2437	172.98	22.38	1W/30 dBm
11	2462	169.43	22.29	1W/30 dBm

-
- Comments : Maximum Peak Output Power < 30dBm (1Watt)

5.4. Power Spectral Density

5.4.1. Measuring Instruments :

As described in chapter 6 of this test report.

5.4.2. Test Procedure :

1. The transmitter output was connected to spectrum analyzer through an attenuator.
2. The spectrum analyzer's resolution bandwidth were set at 3KHz RBW and 30KHz VBW as that of the fundamental frequency. Set the sweep time=span/3KHz.
3. The power spectral density was measured and recorded.
4. The Sweep time is allowed to be longer than span/3KHz for a full response of the mixer in the spectrum analyzer.

5.4.3. Test Setup Layout :

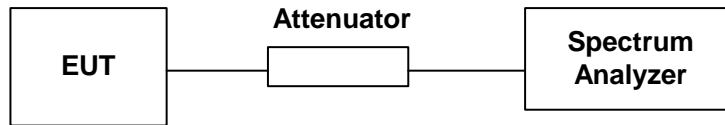

5.4.4. Test Result : See spectrum analyzer plots below

- Temperature : 21°C
- Relative Humidity : 60.5 %

Channel	Frequency (MHz)	Power Spectral Density (dBm)	Limits (dBm)	Plot Ref. No.
1	2412	-6.78	8	1
6	2437	-7.29	8	2
11	2462	-9.47	8	3

Plot1(Channel 1):

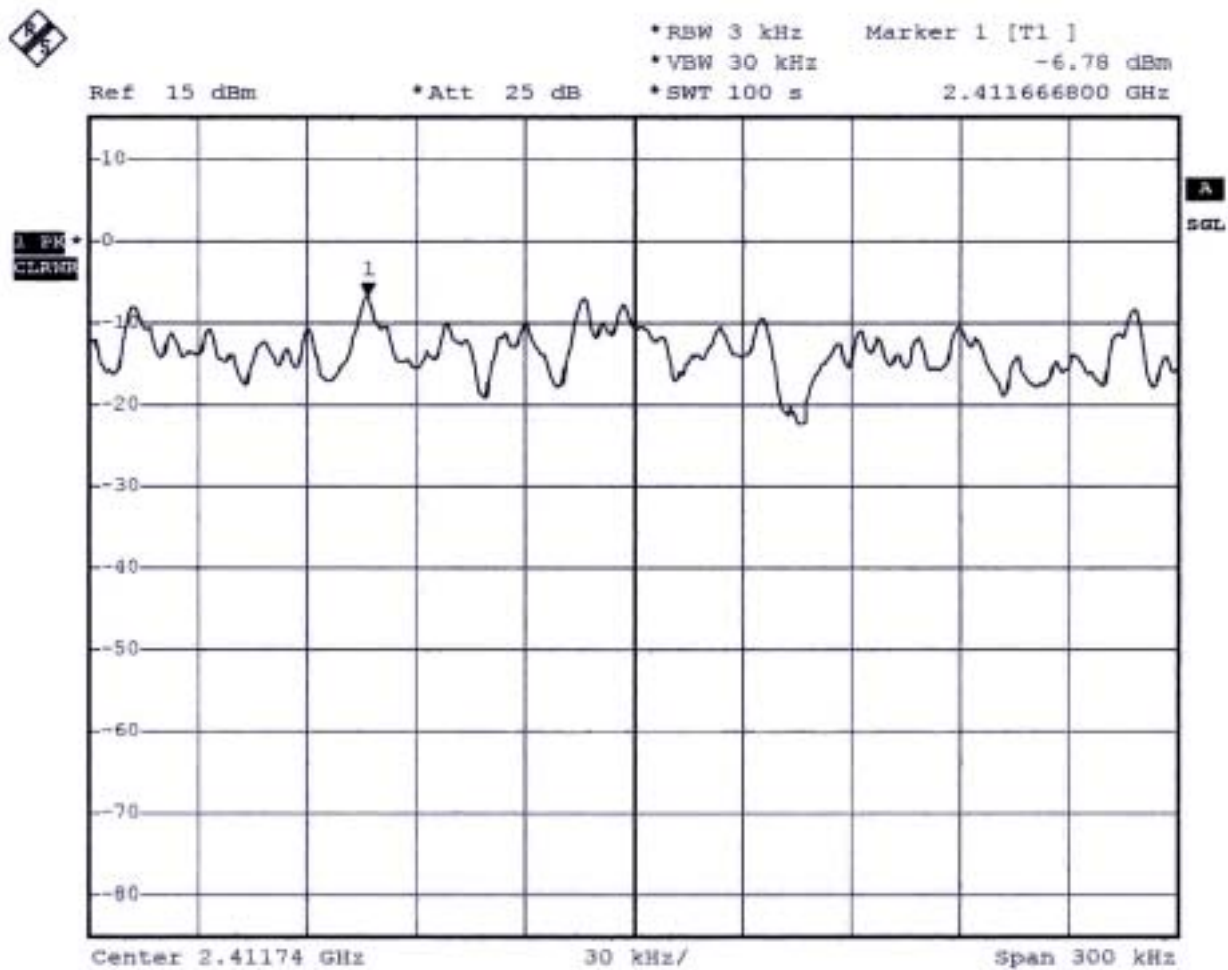

Date: 15.JAN.2003 22:13:30

Plot2(Channel 6):

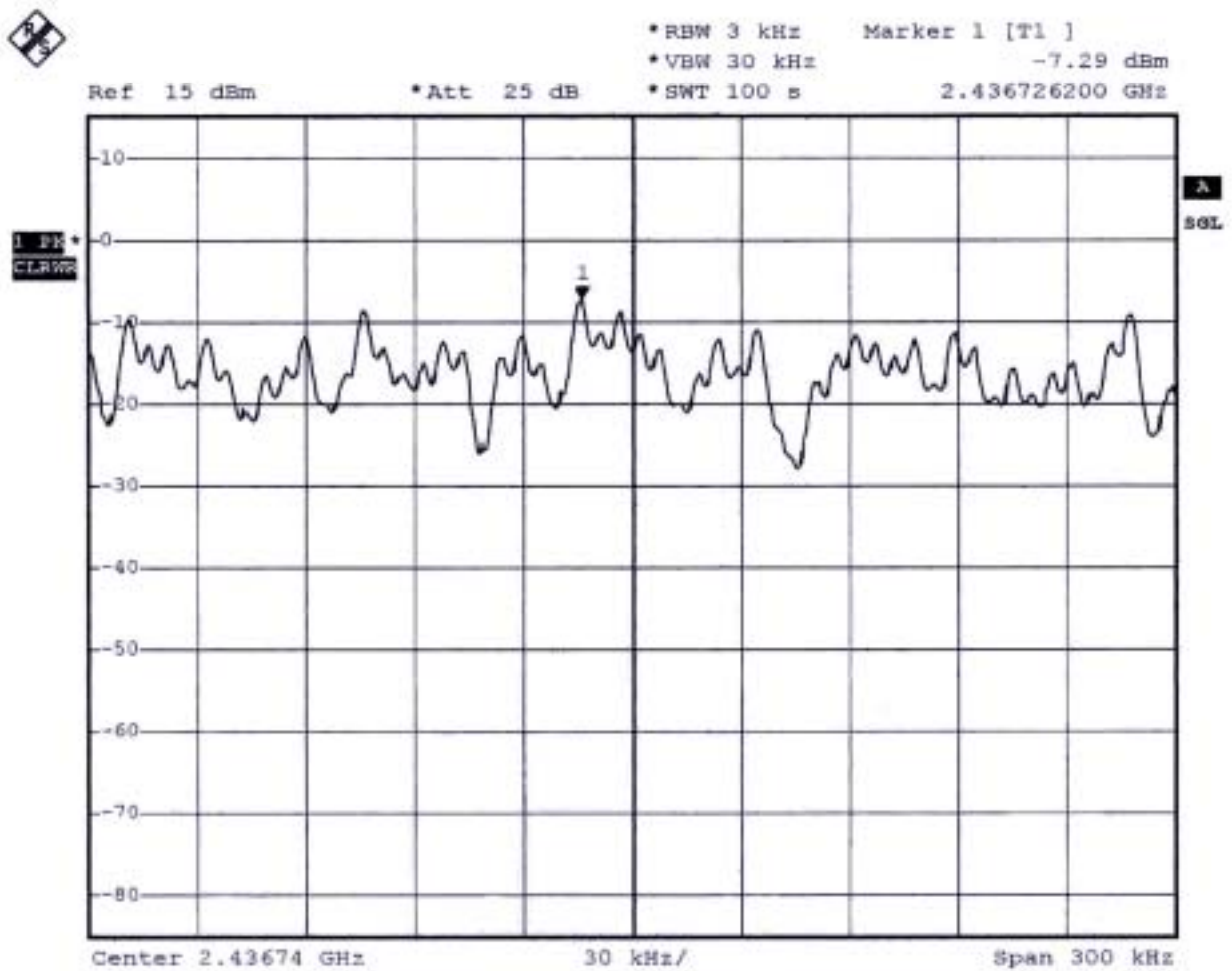

Date: 15.JAN.2003 22:17:31

Plot3(Channel 11):

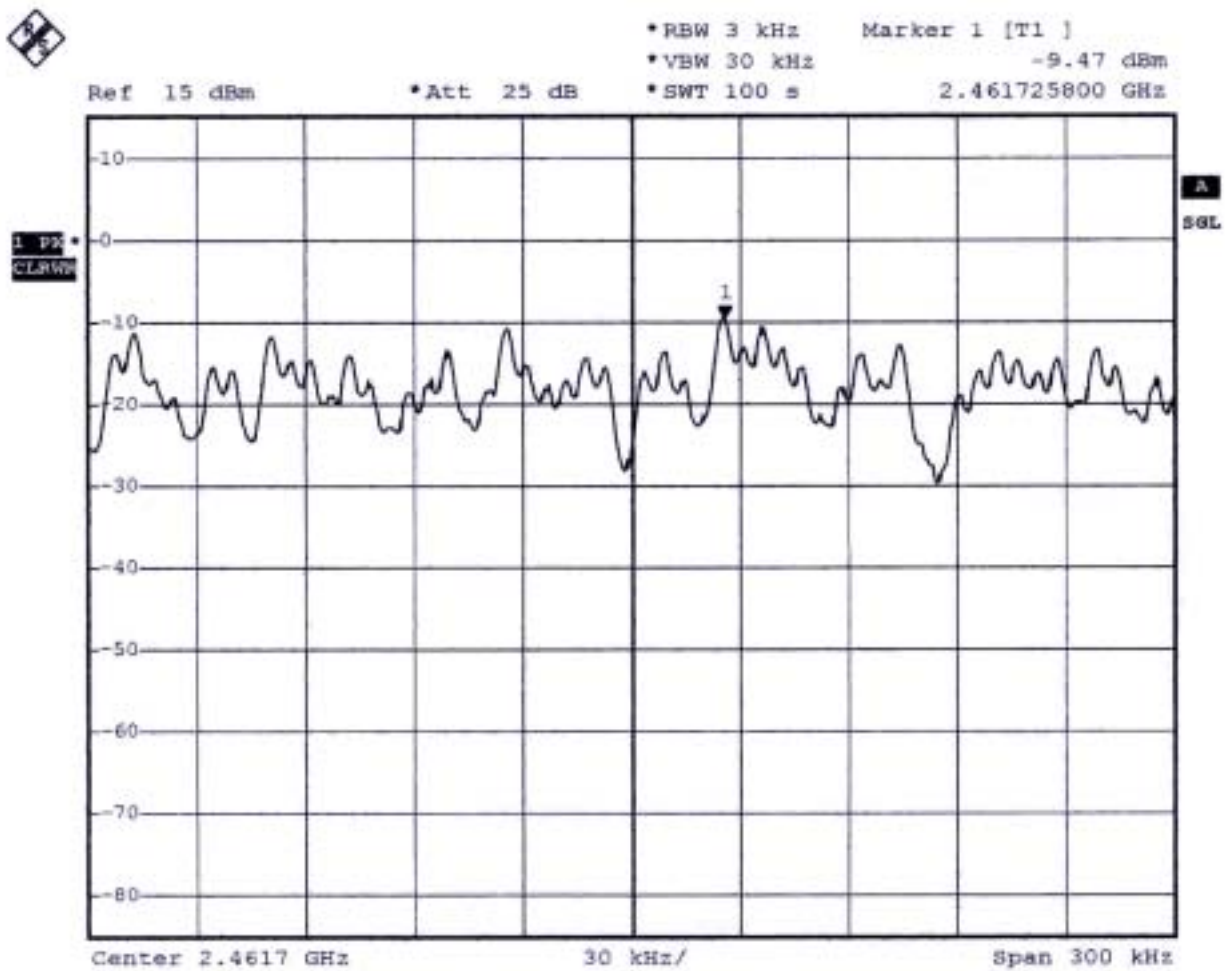

Date: 15.JAN.2003 22:22:34

5.5. Test of Conducted Emission

Conducted Emissions were measured from 150 KHz to 30 MHz with a bandwidth of 9 KHz and return leads of the EUT according to the methods defined in ANSI C63.4-1992 Section 3.1. The EUT was placed on a nonmetallic stand in a shielded room 0.8 meters above the ground plane. The interface cables and equipment positioning were varied within limits of reasonable applications to determine the position produced maximum conducted emissions.

5.5.1. Major Measuring Instruments :

● Test Receiver	(R&S ESCS 30)
Attenuation	10 dB
Start Frequency	0.15 MHz
Stop Frequency	30 MHz
IF Bandwidth	9 KHz

5.5.2. Test Procedures :

- a. The EUT was placed 0.4 meter from the conducting wall of the shielding room was kept at least 80 centimeters from any other grounded conducting surface.
- b. Connect EUT to the power mains through a line impedance stabilization network (LISN).
- c. All the support units are connect to the other LISN.
- d. The LISN provides 50 ohm coupling impedance for the measuring instrument.
- e. The FCC states that a 50 ohm, 50 microhenry LISN should be used.
- f. Both sides of AC line were checked for maximum conducted interference.
- g. The frequency range from 150 KHz to 30 MHz was searched.
- h. Set the test-receiver system to Peak Detect Function and Specified Bandwidth with Maximum Hold Mode.

5.5.3. Test Result of Conducted Emission :

- Test Mode: Mode 1
- Frequency Range of Test: from 150KHz to 30 MHz
- 6dB Bandwidth: 9KHz
- Temperature: 23.5°C
- Relative Humidity: 57 %
- Test Date: Jan. 17, 2003

The test was passed at the minimum margin that marked under gray area in the following table

Frequency (MHz)	Line or Neutral	Meter Reading		Limits		Margin	
		Q.P. (dBuV)	A.V. (dBuV)	Q.P. (dBuV)	A.V. (dBuV)	Q.P. (dB)	A.V. (dB)
0.162	L	46.49	21.50	65.36	55.36	-18.87	-33.86
0.178	L	46.59	18.88	64.58	54.58	-17.99	-35.70
0.243	L	42.85	15.83	61.99	51.99	-19.14	-36.16
0.489	L	37.28	12.36	56.18	46.18	-18.90	-33.82
5.870	L	30.00	24.28	60.00	50.00	-30.00	-25.72
21.600	L	36.28	28.71	60.00	50.00	-23.72	-21.29
0.184	N	46.89	19.07	64.30	54.30	-17.41	-35.23
0.273	N	42.59	15.68	61.03	51.03	-18.44	-35.35
0.384	N	40.93	14.95	58.19	48.19	-17.26	-33.24
0.589	N	38.92	13.31	56.00	46.00	-17.08	-32.69
6.420	N	35.03	29.86	60.00	50.00	-24.97	-20.14
11.560	N	23.79	18.55	60.00	50.00	-36.21	-31.45

Test Engineer : 
 John Huang

- Test Mode: Mode 2
- Frequency Range of Test: from 150KHz to 30 MHz
- 6dB Bandwidth: 9KHz
- Temperature: 23.5°C
- Relative Humidity: 57 %
- Test Date: Jan. 17, 2003

The test was passed at the minimum margin that marked under gray area in the following table

Frequency (MHz)	Line or Neutral	Meter Reading		Limits		Margin	
		Q.P. (dBuV)	A.V. (dBuV)	Q.P. (dBuV)	A.V. (dBuV)	Q.P. (dB)	A.V. (dB)
0.163	L	46.51	21.50	65.31	55.31	-18.80	-33.81
0.187	L	46.31	18.64	64.17	54.17	-17.86	-35.53
0.323	L	40.51	14.44	59.63	49.63	-19.12	-35.19
0.476	L	37.52	12.33	56.41	46.41	-18.89	-34.08
0.661	L	33.80	9.95	56.00	46.00	-22.20	-36.05
21.150	L	36.77	30.09	60.00	50.00	-23.23	-19.91
0.182	N	46.99	19.29	64.39	54.39	-17.40	-35.10
0.346	N	41.49	15.83	59.06	49.06	-17.57	-33.23
0.415	N	40.52	14.95	57.55	47.55	-17.03	-32.60
0.568	N	39.12	13.35	56.00	46.00	-16.88	-32.65
0.630	N	38.53	12.36	56.00	46.00	-17.47	-33.64
4.891	N	32.17	24.35	56.00	46.00	-23.83	-21.65

Test Engineer :



John Huang

- Test Mode: Mode 3
- Frequency Range of Test: from 150KHz to 30 MHz
- 6dB Bandwidth: 9KHz
- Temperature: 23.5°C
- Relative Humidity: 57 %
- Test Date: Jan. 17, 2003

The test was passed at the minimum margin that marked under gray area in the following table

Frequency (MHz)	Line or Neutral	Meter Reading		Limits		Margin	
		Q.P. (dBuV)	A.V. (dBuV)	Q.P. (dBuV)	A.V. (dBuV)	Q.P. (dB)	A.V. (dB)
0.178	L	46.65	18.96	64.58	54.58	-17.93	-35.62
0.255	L	42.37	15.44	61.59	51.59	-19.22	-36.15
0.323	L	40.55	14.50	59.63	49.63	-19.08	-35.13
0.500	L	37.12	12.19	56.00	46.00	-18.88	-33.81
0.598	L	35.31	10.83	56.00	46.00	-20.69	-35.17
21.600	L	36.42	29.13	60.00	50.00	-23.58	-20.87
0.176	N	47.12	19.37	64.67	54.67	-17.55	-35.30
0.315	N	41.89	15.45	59.84	49.84	-17.95	-34.39
0.393	N	40.86	15.06	58.00	48.00	-17.14	-32.94
0.592	N	38.96	13.24	56.00	46.00	-17.04	-32.76
5.710	N	33.75	27.19	60.00	50.00	-26.25	-22.81
21.260	N	36.63	29.94	60.00	50.00	-23.37	-20.06

Test Engineer : John
 John Huang

5.6. Test of Radiated Emission

Radiated emissions from 30 MHz to 25 GHz were measured according to the methods defines in ANSI C63.4-1992. The EUT was placed on a nonmetallic stand in the open-field site, 0.8 meter above the ground plane, as shown in section 4.6.3. The interface cables and equipment positions were varied within limits of reasonable applications to determine the positions producing maximum radiated emissions

5.6.1. Major Measuring Instruments

- from 30MHz to 1GHz
 - Amplifier (HP 8447D)
 - RF Gain 30 dB
 - Signal Input 100 KHz to 1.3 GHz
 - Spectrum Analyzer (R&S FSP)
 - Attenuation 10 dB
 - Start Frequency 30 MHz
 - Stop Frequency 1000 MHz
 - Resolution Bandwidth 120 KHz
 - Signal Input 9 KHz to 7 GHz

- above 1GHz
 - Spectrum analyzer (R&S FSP40)
 - Attenuation 10 dB
 - Start Frequency 1 GHz
 - Stop Frequency 25 GHz
 - Resolution Bandwidth 1 MHz
 - Video Bandwidth 1 MHz
 - Signal Input 9 KHz to 40 GHz
 - Amplifier (MITEQ AFS44)
 - RF Gain 40 dB
 - Signal Input 100 MHz to 26.5GHz

5.6.2. Test Procedures

1. The EUT was placed on a rotatable table top 0.8 meter above ground.
2. The EUT was set 3 meters from the interference receiving antenna which was mounted on the top of a variable height antenna tower.
3. The table was rotated 360 degrees to determine the position of the highest radiation.
4. The antenna is a broadband antenna and its height is varied between one meter and four meters above ground to find the maximum value of the field strength both horizontal polarization and vertical polarization of the antenna are set to make the measurement.
5. For each suspected emission the EUT was arranged to its worst case and then tune the antenna tower (from 1 M to 4 M) and turn table (from 0 degree to 360 degrees) to find the maximum reading.
6. Set the test-receiver system to Peak or CISPR quasi-peak Detect Function and specified bandwidth with Maximum Hold Mode.
7. If the emission level of the EUT in peak mode was 3 dB lower than the limit specified, then testing will be stopped and peak values of EUT will be reported, otherwise, the emissions which do not have 3 dB margin will be repeated one by one using the quasi-peak method and reported.
8. For testing above 1GHz, the emission level of the EUT in peak mode was 20dB lower than average limit (that means the emission level in peak mode also complies with the limit in average mode), then testing will be stopped and peak values of EUT will be reported, otherwise, the emissions will be measured in average mode again and reported.

5.6.3. Typical Test Setup Layout of Radiated Emission

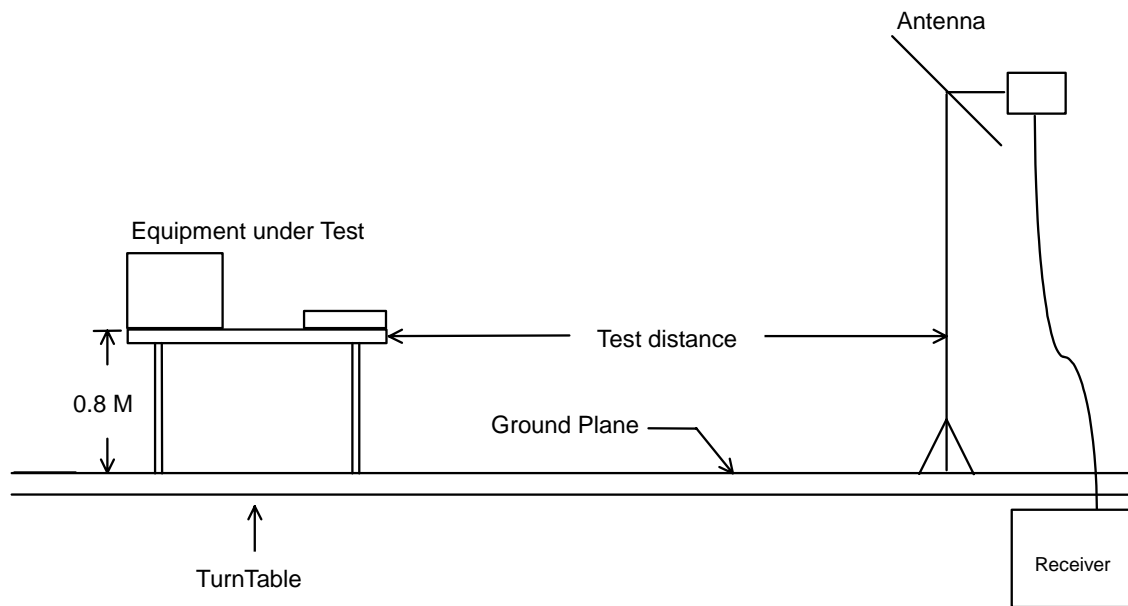

5.6.4. Test Result of Radiated Emission

- Test Mode: Mode 1
- Test Distance: 3 M
- Temperature: 21 °C
- Relative Humidity: 60.5 %
- Test Date: Jan. 10, 2003
- Emission level (dBuV/m) = 20 log Emission level (uV/m)
- Corrected Reading: Antenna Factor + Cable Loss + Reading = Emission

The test was passed at the minimum margin that marked under gray area in the following table, and its antenna height is 1 m, turn table degree is 75 °

■ Spurious Emission

- For 30MHz to 1GHz

Frequency (MHz)	Antenna Polarity	Cable Factor	Reading Loss	Limits (dBuV)	Emission (dBuV/m)	Level (uV/m)	Margin (dB)	Detect Mode		
250.050	H	11.85	3.14	25.84	46.00	199.53	40.83	110.03	-5.17	Peak
264.090	H	11.71	3.26	27.06	46.00	199.53	42.03	126.33	-3.97	Peak
650.000	H	17.64	5.82	18.04	46.00	199.53	41.50	118.85	-4.50	Peak
39.450	V	11.11	1.18	24.67	40.00	100.00	36.96	70.47	-3.04	Peak
250.050	V	11.85	3.14	25.97	46.00	199.53	40.96	111.69	-5.04	Peak
264.090	V	11.71	3.26	26.62	46.00	199.53	41.59	120.09	-4.41	Peak

- For above 1GHz

Frequency (MHz)	Antenna Polarity	Cable Factor	Reading Loss	Limits (dBuV)	Emission (dBuV/m)	Level (uV/m)	Margin (dB)	Detect Mode		
2374.000	V	30.61	5.15	9.98	74.00	5011.87	45.74	193.64	-28.26	Peak
2462.000	V	30.53	5.25	9.86	74.00	5011.87	45.64	191.43	-28.36	Peak
2550.000	V	30.48	5.35	9.62	74.00	5011.87	45.45	187.28	-28.55	Peak

■ Field strength of fundamental and harmonics

Frequency (MHz)	Antenna Polarity	Cable Factor	Reading Loss	Limits (dBuV)	Emission (dBuV/m)	Level (uV/m)	Margin (dB)	Detect Mode	
2412.000	H	30.58	5.20	52.79	-	-	88.57	26822.55	Peak
2412.000	H	30.58	5.20	39.29	-	-	75.07	5668.92	A.V.
2412.000	V	30.58	5.20	66.30	-	-	102.08	127057.41	Peak
2412.000	V	30.58	5.20	52.80	-	-	88.58	26853.44	A.V.
4824.000	V/H						-		Peak, A.V.
7236.000	V/H						-		Peak, A.V.
9648.000	V/H						-		Peak, A.V.
12060.000	V/H						-		Peak, A.V.
14472.000	V/H						-		Peak, A.V.
16884.000	V/H						-		Peak, A.V.
19296.000	V/H						-		Peak, A.V.
21708.000	V/H						-		Peak, A.V.
24120.000	V/H						-		Peak, A.V.

Remark: The emission emitted by the EUT is too low to be measured except the emission listed above

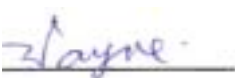
Test Engineer : 
Wayne Hsu

- Test Mode: Mode 2
- Test Distance: 3 M
- Temperature: 21 °C
- Relative Humidity: 60.5 %
- Test Date: Jan. 10, 2003
- Emission level (dBuV/m) = 20 log Emission level (uV/m)
- Corrected Reading: Antenna Factor + Cable Loss + Reading = Emission

The test was passed at the minimum margin that marked under gray area in the following table, and its antenna height is 1 m, turn table degree is 83 °

- Spurious Emission
 - For 30MHz to 1GHz

Frequency (MHz)	Antenna Polarity	Cable Factor	Reading Loss	Limits (dBuV)	Emission (dBuV/m)	Level (uV/m)	Margin (dB)	Detect Mode		
253.290	H	11.82	3.17	25.69	46.00	199.53	40.68	108.14	-5.32	Peak
439.300	H	15.18	4.22	21.18	46.00	199.53	40.58	106.91	-5.42	Peak
792.100	H	18.73	6.44	15.46	46.00	199.53	40.63	107.52	-5.37	Peak
40.530	V	10.98	1.19	23.22	40.00	100.00	35.39	58.82	-4.61	Peak
250.050	V	11.85	3.14	25.91	46.00	199.53	40.90	110.92	-5.10	Peak
264.090	V	11.71	3.26	26.27	46.00	199.53	41.24	115.35	-4.76	Peak

- For above 1GHz

Frequency (MHz)	Antenna Polarity	Cable Factor	Reading Loss	Limits (dBuV)	Emission (dBuV/m)	Level (uV/m)	Margin (dB)	Detect Mode		
4598.000	H	32.92	7.39	5.92	74.00	5011.87	46.23	204.88	-27.77	Peak
2388.000	V	30.60	5.17	5.86	74.00	5011.87	41.63	120.64	-32.37	Peak
4876.000	V	33.76	7.49	6.22	74.00	5011.87	47.47	236.32	-26.53	Peak

■ Field strength of fundamental and harmonics

Frequency (MHz)	Antenna Polarity	Cable Factor	Reading Loss	Limits (dBuV)	Emission (dBuV/m)	Level (uV/m)	Margin (dB)	Detect Mode	
2438.000	H	30.55	5.23	50.63	-	-	86.41	20917.03	Peak
2438.000	H	30.55	5.23	47.09	-	-	82.87	13915.54	A.V.
2438.000	V	30.55	5.23	59.49	-	-	95.27	58009.62	Peak
2438.000	V	30.55	5.23	45.99	-	-	81.77	12260.27	A.V.
4876.000	V/H						-		Peak, A.V.
7314.000	V/H						-		Peak, A.V.
9752.000	V/H						-		Peak, A.V.
12190.000	V/H						-		Peak, A.V.
14628.000	V/H						-		Peak, A.V.
17066.000	V/H						-		Peak, A.V.
19504.000	V/H						-		Peak, A.V.
21942.000	V/H						-		Peak, A.V.
24380.000	V/H						-		Peak, A.V.

Remark: The emission emitted by the EUT is too low to be measured except the emission listed above

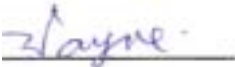
Test Engineer : 
Wayne Hsu

- Test Mode: Mode 3
- Test Distance: 3 M
- Temperature: 21 °C
- Relative Humidity: 60.5 %
- Test Date: Jan. 10, 2003
- Emission level (dBuV/m) = 20 log Emission level (uV/m)
- Corrected Reading: Antenna Factor + Cable Loss + Reading = Emission

The test was passed at the minimum margin that marked under gray area in the following table, and its antenna height is 1 m, turn table degree is 105 °

■ Spurious Emission

- For 30MHz to 1GHz

Frequency (MHz)	Antenna Polarity	Cable Factor	Reading Loss	Limits (dBuV)	Emission (dBuV/m)	Level (uV/m)	Margin (dB)	Detect Mode		
253.290	H	11.82	3.17	25.27	46.00	199.53	40.26	103.04	-5.74	Peak
439.300	H	15.18	4.22	21.37	46.00	199.53	40.77	109.27	-5.23	Peak
792.100	H	18.73	6.44	15.35	46.00	199.53	40.52	106.17	-5.48	Peak
40.530	V	10.98	1.19	23.34	40.00	100.00	35.51	59.63	-4.49	Peak
250.050	V	11.85	3.14	25.72	46.00	199.53	40.71	108.52	-5.29	Peak
264.090	V	11.71	3.26	25.42	46.00	199.53	40.39	104.59	-5.61	Peak

- For above 1GHz

Frequency (MHz)	Antenna Polarity	Cable Factor	Reading Loss	Limits (dBuV)	Emission (dBuV/m)	Level (uV/m)	Margin (dB)	Detect Mode		
2404.000	H	30.58	5.19	5.19	74.00	5011.87	40.96	111.69	-33.04	Peak
2750.000	H	30.40	5.58	5.06	74.00	5011.87	41.04	112.72	-32.96	Peak
2374.000	V	30.61	5.15	6.06	74.00	5011.87	41.82	123.31	-32.18	Peak
4922.000	V	33.90	7.51	5.88	74.00	5011.87	47.29	231.47	-26.71	Peak

■ Field strength of fundamental and harmonics

Frequency (MHz)	Antenna Polarity	Cable Factor (dB/m)	Cable Loss (dB)	Reading (dBuV)	Limits (dBuV/m)	Emission (uV/m)	Level (dBuV/m)	Margin (uV/m)	Detect (dB)	Mode
2462.000	H	30.53	5.25	38.52	-	-	74.30	5188.00		Peak
2462.000	H	30.53	5.25	52.02	-	-	87.80	24547.09		A.V.
2462.000	V	30.53	5.25	61.38	-	-	97.16	72110.75		Peak
2462.000	V	30.53	5.25	47.88	-	-	83.66	15240.53		A.V.
4924.000	V/H						-			Peak, A.V.
7386.000	V/H						-			Peak, A.V.
9848.000	V/H						-			Peak, A.V.
12310.000	V/H						-			Peak, A.V.
14772.000	V/H						-			Peak, A.V.
17234.000	V/H						-			Peak, A.V.
19696.000	V/H						-			Peak, A.V.
22158.000	V/H						-			Peak, A.V.
24620.000	V/H						-			Peak, A.V.

Remark: The emission emitted by the EUT is too low to be measured except the emission listed above

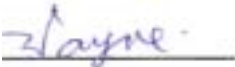
Test Engineer : 
Wayne Hsu

5.7. Band Edges Measurement

5.7.1. Measuring Instruments :

As described in chapter 6 of this test report.

5.7.2. Test Procedure :

1. The transmitter output was connected to the spectrum analyzer via a low lose cable.
2. Set both RBW and VBW of spectrum analyzer to 100KHz with convenient frequency span including 100 KHz bandwidth from band edge.
3. The band edges was measured and recorded.

5.7.3. Test Result :

- Test Result in lower band (Channel 1) : PASS
- Test Result in higher band(Channel 11) : PASS

5.7.4. Note on Band edge Emission

The band edge emission plot on page 37. shows 45.10dB delta between carrier maximum power and local maximum emission in the restricted band (2.4835GHz).

Polarity	The emission of carrier power strength (dB μ V/m)	The maximum field strength in restrict band (dB μ V/m)	Limit (dB μ V/m)	Margin (dB)	Result
H	87.80	26.08	74.00	-47.92	Peak
H	74.30	12.58	54.00	-41.42	Average
V	97.16	35.44	74.00	-38.56	Peak
V	83.66	21.94	54.00	-32.06	Average

* The maximum field strength in restricted band is the emission of carrier power strength subtract to the delta between carrier maximum power and local maximum emission in the restricted band.

The spectrum analyzer plots are attached as below :

Plot1 (Channel 1) :

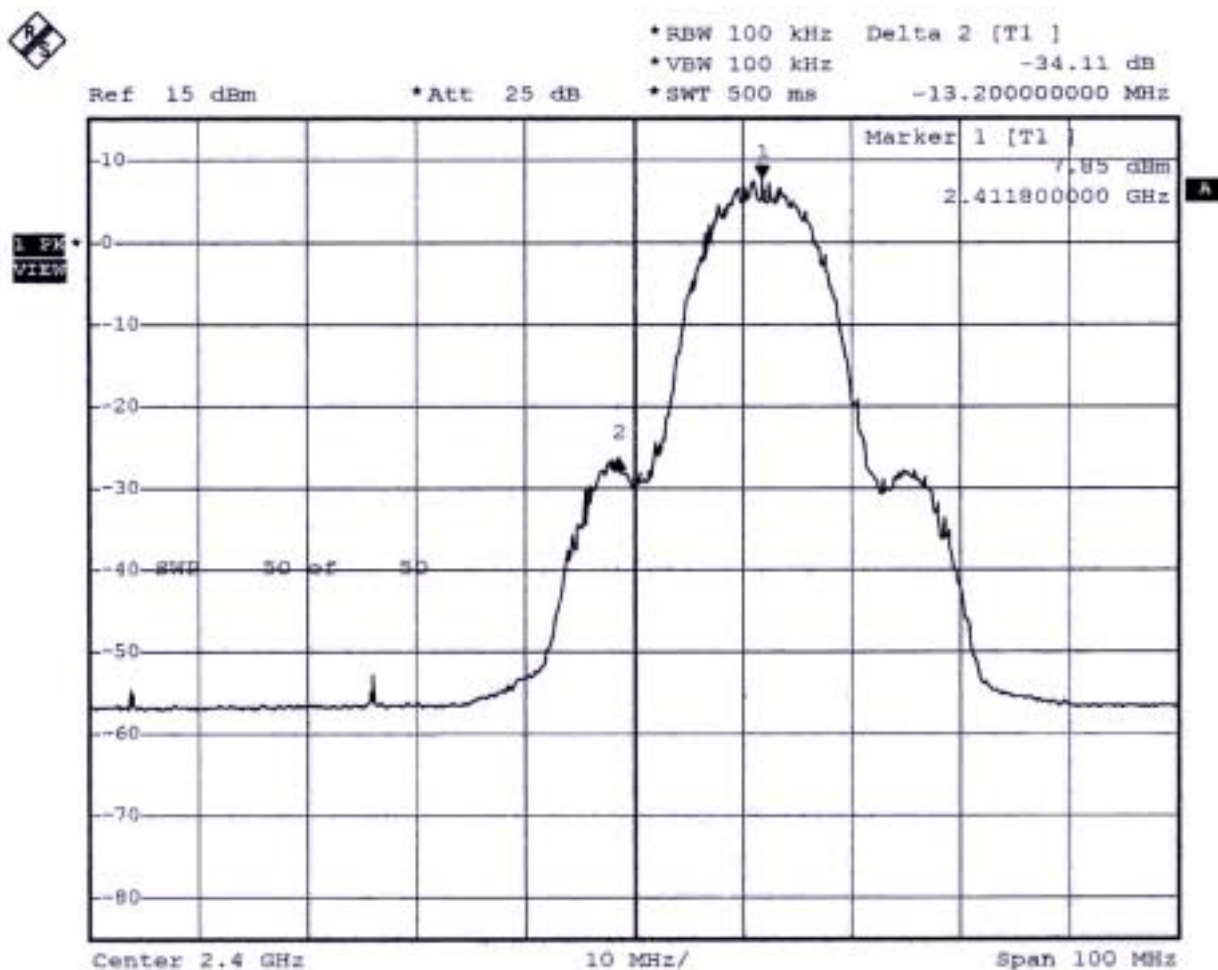

Date: 15.JAN.2003 22:10:51

Plot2 (Channel 11) :

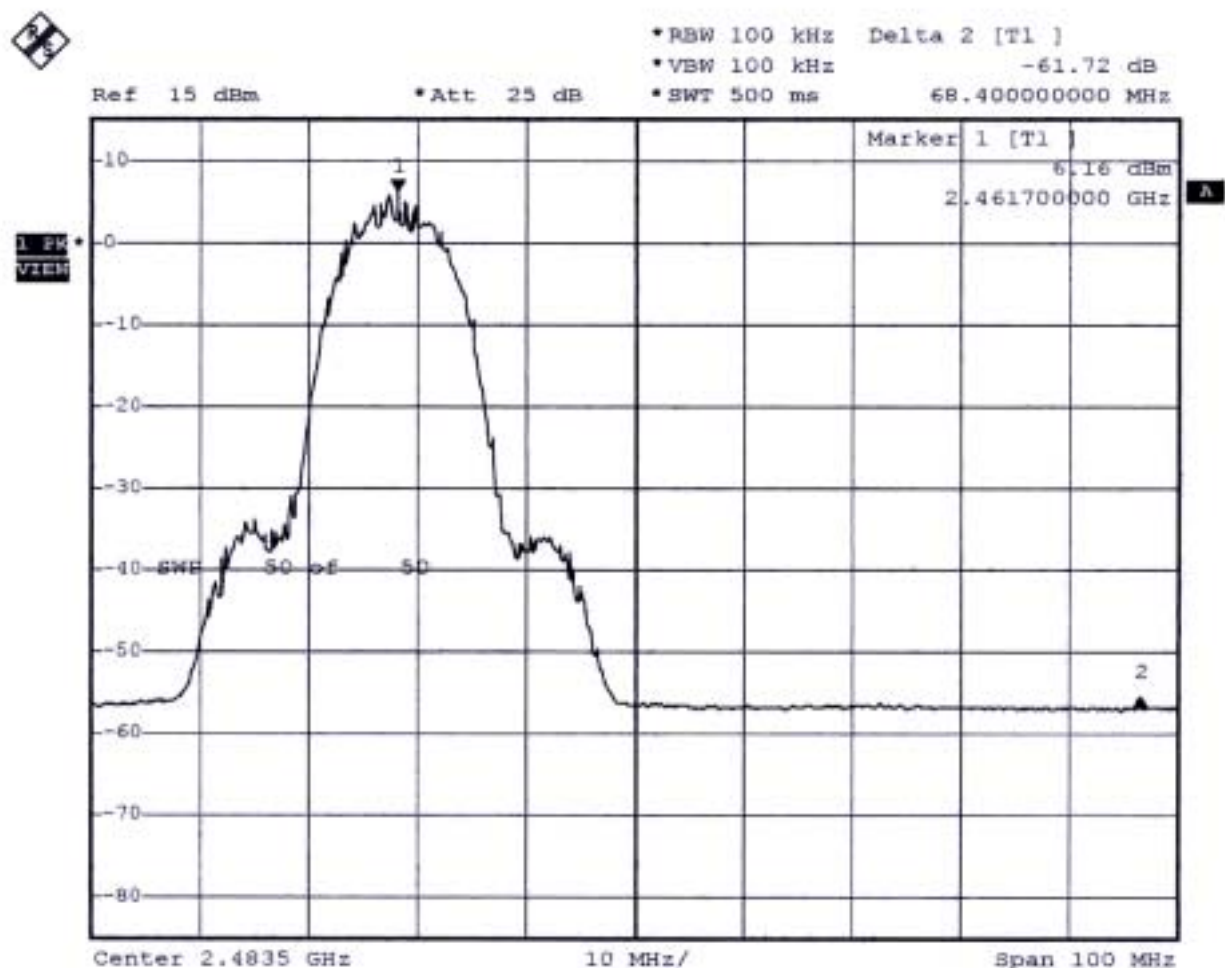

Date: 15.JAN.2003 22:20:20

Comments : All emissions in any 100kHz bandwidth outside the band edge are attenuated more then 20dB from the carrier.

5.8. Antenna Requirements

5.8.1. Antenna Connected Construction

The EUT use a permanently undetachable antenna. It is considered meet antenna requirement of FCC.

The coaxial cable of the antenna is fixed to the antenna.

The antenna used in this product is a dipole antenna.

5.8.2. Standard Applicable

For intentional device, according to FCC 47 CFR Section 15.203, an intentional radiator shall be designed to ensure that no antenna other than that furnished by the responsible party shall be used with the device.

And according to FCC 47 CFR Section 15.247 (b), if transmitting antennas of directional gain greater than 6dBi are used, the power shall be reduced by the amount in dB that the directional gain of the antenna exceeds 6dBi.

5.9. RF Exposure

FCC Rules and Regulations Part 1.1307,1.1310,2.1091,2.1093:

RF Exposure Compliance

5.9.1. Limit For Maximum Permissible Exposure (MPE)

(A) Limits for Occupational / Controlled Exposure

Frequency Range (MHz)	Electric Field Strength (E) (V/m)	Magnetic Field Strength (H) (A/m)	Power Density (S) (mW/ cm ²)	Averaging Time E ² , H ² or S (minutes)
0.3-3.0	614	1.63	(100)*	6
3.0-30	1842/f	4.89/f	(900/f)*	6
30-300	61.4	0.163	1.0	6
300-1500			F/300	6
1500-100,000			5	6

(B) Limits for General Population / Uncontrolled Exposure

Frequency Range (MHz)	Electric Field Strength (E) (V/m)	Magnetic Field Strength (H) (A/m)	Power Density (S) (mW/cm ²)	Averaging Time E ² , H ² or S (minutes)
0.3-1.34	614	1.63	(100)*	30
1.34-30	824/f	2.19/f	(180/f)*	30
30-300	27.5	0.073	0.2	30
300-1500			F/1500	30
1500-100,000			1.0	30

F=frequency in MHz

*Plane-wave equivalent power density

5.9.2. MPE Calculations

$$E \text{ (V/m)} = \frac{\sqrt{30 \times P \times G}}{d} \quad \text{Power Density: } Pd \text{ (mW/cm}^2\text{)} = \frac{E^2}{3770}$$

- E = Electric field (V/m)
- P = Peak output power (mW)
- G = Antenna numeric gain (numeric)
- d = Separation distance (m)

Because the EUT is belong to General Population/ Uncontrolled Exposure. So the Limit of Power Density is 1.0 mW/cm². We can change the formula to:

$$d = \sqrt{\frac{30 \times P \times G}{3770}}$$

Channel NO.	Antenna Gain (dBi)	Antenna Gain (numeric)	Peak Output Power (dBm)	Peak Output Power (mW)	Calculated RF Exposure Separation Distance (cm)	Minimum RF Exposure Separation Distance (cm)
Channel 1	2.00	1.58	23.17	207.49	5.1	20
Channel 6	2.00	1.58	22.38	172.98	4.7	20
Channel 11	2.00	1.58	22.29	169.43	4.6	20

5.9.3. FCC Radiation Exposure Statement

This equipment complies with FCC radiation exposure limits set forth for an uncontrolled environment. In order to avoid the possibility of exceeding the FCC radio frequency exposure limits, human proximity to the antenna shall not be less than 20cm (8 inches) during normal operation. Proposed RF exposure safety information to include in User's Manual.

6. EMI Suppression Component List

No EMI suppression components.

7. Antenna Factor & Cable Loss

- from 30MHz to 1GHz

Frequency (MHz)	Antenna Factor (dB)	Cable Loss (dB)
30	15.35	1.00
35	13.63	1.08
40	11.11	1.18
45	10.59	1.24
50	6.47	1.30
55	5.83	1.38
60	5.18	1.44
65	4.81	1.52
70	4.43	1.59
75	5.10	1.68
80	5.91	1.75
85	7.33	1.77
90	8.74	1.83
95	9.05	1.85
100	9.36	1.90
110	9.65	2.01
120	9.97	2.06
130	10.51	2.16
140	10.32	2.24
150	9.42	2.34
160	8.09	2.42
170	7.43	2.56
180	7.60	2.62
190	7.43	2.67
200	7.26	2.76
220	9.11	2.92
240	10.88	3.09
260	11.75	3.23
280	11.55	3.38
300	11.36	3.51
320	12.03	3.63
340	12.69	3.73
360	13.33	4.03
380	14.00	4.00
400	14.63	4.09
450	15.33	4.31
500	16.03	4.64
550	16.65	5.09
600	17.29	5.49
650	17.64	5.82
700	18.00	5.94
750	18.39	6.16
800	18.79	6.58
850	19.10	6.72
900	19.42	6.81
950	19.58	7.10
1000	19.75	7.41

- above 1GHz

Frequency (MHz)	Antenna Factor (dB)	Cable Loss (dB)
1000	24.30	3.89
2000	31.10	5.41
3000	29.60	6.92
4000	30.80	8.24
5000	34.20	9.22

8. List of Measuring Equipments Used

Instrument	Manufacturer	Model No.	Serial No.	Characteristics	Calibration Date	Remark
EMC Receiver	R&S	ESCS 30	100132	9 KHz – 2.75 GHz	Jun. 03, 2002	Conduction (CO01-HY)
LISN	MessTec	NNB-2/16Z	2001-008	9 KHz – 30 MHz	Apr. 30, 2002	Conduction (CO01-HY)
LISN (Support Unit)	MessTec	NNB-2/16Z	2001-009	9 KHz – 30 MHz	Apr. 30, 2002	Conduction (CO01-HY)
EMI Filter	LINDGREN	LRE-2060	1004	< 450 Hz	N/A	Conduction (CO01-HY)
EMI Filter	LINDGREN	N6006	201052	0 ~ 60 Hz	N/A	Conduction (CO01-HY)
Spectrum analyzer	R&S	FSP	100004/040	9KHZ~40GHZ	Aug. 07, 2002	Radiation (03CH03-HY)
Amplifier	HP	8447D	2944A09072	100KHz – 1.3GHz	Oct. 21, 2002	Radiation (03CH03-HY)
Bilog Antenna	SCHAFFNER	CBL6112B	2687	30MHz –2GHz	Dec. 21, 2002	Radiation (03CH03-HY)
Turn Table	HD	DS 420	420/650/00	0 ~ 360 degree	N/A	Radiation (03CH03-HY)
Antenna Mast	HD	MA 240	240/560/00	1 m - 4 m	N/A	Radiation (03CH03-HY)
Half-wave dipole antenna	R&S	HZ12 HZ13	83924403 83924503	30MHz - 1GHz	Sep. 23, 2002	Radiation (03CH03-HY)
Horn Antenna	COM-POWER	AH-118	10094	1GHz – 18GHz	Apr. 09, 2002	Radiation
Spectrum analyzer	R&S	FSP40	100004/040	9KHZ~40GHZ	Aug. 07, 2002	Radiation
Amplifier	MITEQ	AFS44	879981	100MHz~26.5GHz	Aug. 12, 2002	Radiation

Calibration Interval of instruments listed above is one year.

9. Uncertainty of Test Site

Uncertainty of Radiated Emission Measurement

Contribution	Probability Distribution	3m
Antenna factor calibration	normal(k=2)	±1
cable loss calibration	normal(k=2)	±0.3
RCV/SPA specification	rectangular	±2
Antenna Directivity	rectangular	±3
Antenna Factor V.S. Height	rectangular	±2
Antenna Factor Interpolation for Frequency	rectangular	±0.25
site imperfection	rectangular	±2
Mismatch Receiver VSWR $\Gamma_1=0.09$ Antenna VSWR $\Gamma_2=0.67$ Uncertainty= $20\log(1-\Gamma_1*\Gamma_2)$	U-shaped	±0.54
combined standard uncertainty $U_e(y)$	normal	±2.7
Measuring uncertainty for a level of confidence of 95% $U=2U_e(y)$	normal (k=2)	±5.4

$U = \{((1/2)^2+(0.3/2)^2+(2^2+0.5^2+2^2+0.25^2+2^2)/3+(0.54)^2/2)\}^{1/2}=2.2$ for 10m test distance

$U = \{((1/2)^2+(0.3/2)^2+(2^2+3^2+2^2+0.25^2+2^2)/3+(0.54)^2/2)\}^{1/2}=2.7$ for 3m test distance

Uncertainty of Conducted Emission Measurement

Contribution	Probability Distribution	150KHz – 30MHz
Cable and I/P attenuator calibration	normal(k=2)	±0.3
RCV/SPA specification	rectangular	±2
LISN coupling specification	rectangular	±1.5
Transducer factor frequency interpolation	rectangular	±0.2
Mismatch Receiver VSWR $\Gamma_1=0.09$ LISN VSWR $\Gamma_2=0.33$ Uncertainty= $20\log(1-\Gamma_1*\Gamma_2)$	U-shaped	0.2
combined standard uncertainty $U_e(y)$	normal	±1.66
Measuring uncertainty for a level of confidence of 95% $U=2U_e(y)$	normal (k=2)	±3.32

$U = \{(0.3/2)^2 + (2^2+1.5^2+0.2^2)/3+(0.2)^2/2\}^{1/2}=1.66$