



FCC ID: PY3MP115
Issued on Dec. 16, 2004

Report No.: FR4N2203

FCC TEST REPORT

CATEGORY : Fixed
PRODUCT NAME : Wireless Digital Media Player
FCC ID. : PY3MP115
FILING TYPE : Certification
BRAND NAME : NETGEAR
MODEL NAME : MP115
APPLICANT : **NETGEAR**
4500, GREAT AMERICA PARKWAY, SANTA CLARA, CA
95054
MANUFACTURER : **Delta Electronics, Inc.**
252, Shang Ying Road, Kuei San Taoyuan Hsien 333,
Taiwan, R.O.C.
ISSUED BY : **SPORTON INTERNATIONAL INC.**
6F, No. 106, Sec. 1, Hsin Tai Wu Rd., His Chih, Taipei Hsien,
Taiwan, R.O.C.

Statements:

The test result in this report refers exclusively to the presented test model / sample.

Without written approval of SPORTON International Inc., the test report shall not be reproduced except in full.

Certificate or Test Report could not be used by the applicant to claim the product endorsement by CNLA, NVLAP or any agency of U.S. government.

The test equipment used to perform the test are calibrated and traceable to NML/ROC or NIST/USA.



Lab Code: 200079-0

SPORTON International Inc.

TEL : 886-2-2696-2468

FAX : 886-2-2696-2255



Table of Contents

HISTORY OF THIS TEST REPORT..... II

CERTIFICATE OF COMPLIANCE III

1. GENERAL DESCRIPTION OF EQUIPMENT UNDER TEST 1

1.1. Applicant 1

1.2. Manufacturer 1

1.3. Basic Description of Equipment under Test 1

1.4. Features of Equipment under Test 1

1.5. Antenna Description 2

1.6. Table for Carrier Frequencies 2

2. TEST CONFIGURATION OF THE EQUIPMENT UNDER TEST 3

2.1. Connection Diagram of Test System 3

2.2. The Test Mode Description 3

2.3. Description of Test Supporting Units 3

3. GENERAL INFORMATION OF TEST 4

3.1. Test Facility 4

3.2. Test Conditions 4

3.3. Standards for Methods of Measurement 4

3.4. DoC Statement 4

3.5. Frequency Range Investigated 4

3.6. Test Distance 4

3.7. Test Software 4

4. LIST OF MEASUREMENTS 5

4.1. Summary of the Test Results 5

5. TEST RESULT 6

5.1. Test of 6dB Spectrum Bandwidth 6

5.2. Test of Maximum Conducted Output Power 11

5.3. Test of Peak Power Spectral Density 13

5.4. Test of Band Edges Emission 18

5.5. Test of AC Power Line Conducted Emission 23

5.6. Test of Spurious Radiated Emission 30

5.7. Antenna Requirements 40

5.8. RF Exposure 41

6. LIST OF MEASURING EQUIPMENTS USED 43

APPENDIX A. PHOTOGRAPHS OF EUT..... A1 ~ A25



CERTIFICATE OF COMPLIANCE

with

47 CFR FCC Part 15 Subpart C (Section 15.247)

PRODUCT NAME : Wireless Digital Media Player

BRAND NAME : NETGEAR

MODEL NAME : MP115

APPLICANT : **NETGEAR**

4500, GREAT AMERICA PARKWAY, SANTA CLARA, CA
95054

MANUFACTURER : **Delta Electronics, Inc.**

252, Shang Ying Road, Kuei San Taoyuan Hsien 333,
Taiwan, R.O.C.

I **HEREBY** CERTIFY THAT:

The measurements shown in this test report were made in accordance with the procedures given in ANSI C63.4 - 2003 and all test are performed according to 47 CFR FCC Part 15. Testing was carried out on Dec. 16, 2004 at SPORTON International Inc. LAB.

A handwritten signature in blue ink, appearing to read 'Alan Lane', is written over a horizontal line.

Dr. Alan Lane

Vice General Manager
SPORTON International Inc.



1. General Description of Equipment under Test

1.1. Applicant

NETGEAR

4500, GREAT AMERICA PARKWAY, SANTA CLARA, CA 95054

1.2. Manufacturer

Delta Electronics, Inc.

252, Shang Ying Road, Kuei San Taoyuan Hsien 333, Taiwan, R.O.C.

1.3. Basic Description of Equipment under Test

This product is a Wireless Digital Media Player with 802.11b/g wireless solution. The technical data has been listed on section " Features of Equipment under Test ".

1.4. Features of Equipment under Test

Items	Description
Type of Modulation	DSSS (CCK / DQPSK / DBPSK) OFDM (16QAM / 64QAM / DQPSK / DBPSK)
Number of Channels	11
Frequency Band	2400MHz ~ 2483.5MHz
Carrier Frequency	See section 1.6 for details
Data Rate	CCK : 1, 2, 5.5, 11Mbps OFDM : 54, 48,36, 24,18,12, 6Mbps
Channel Bandwidth	15MHz (802.11b), 18MHz (802.11g)
Max. Conducted Output Power	CCK : 17.10 dBm ; BPSK : 17.20 dBm Turbo: 16.40 dBm
Antenna Type	See section 1.5 for details
Testing Duty Cycle	100.00%
Power Rating (DC/AC, Voltage)	110 VAC from power adapter
Test Power Source	110.00V AC
Temperature Range (Operating)	-10 ~ 55 °C



1.5. Antenna Description

No.	Antenna Type	Gain (dBi)
1	External non-detachable Monopole Antenna	2.00

1.6. Table for Carrier Frequencies

Channel	Frequency	Channel	Frequency	Channel	Frequency	Channel	Frequency
01	2412 MHz	05	2432 MHz	09	2452 MHz	-	-
02	2417 MHz	06	2437 MHz	10	2457 MHz	-	-
03	2422 MHz	07	2442 MHz	11	2462 MHz	-	-
04	2427 MHz	08	2447 MHz	-	-	-	-

2. Test Configuration of the Equipment under Test

2.1. Connection Diagram of Test System

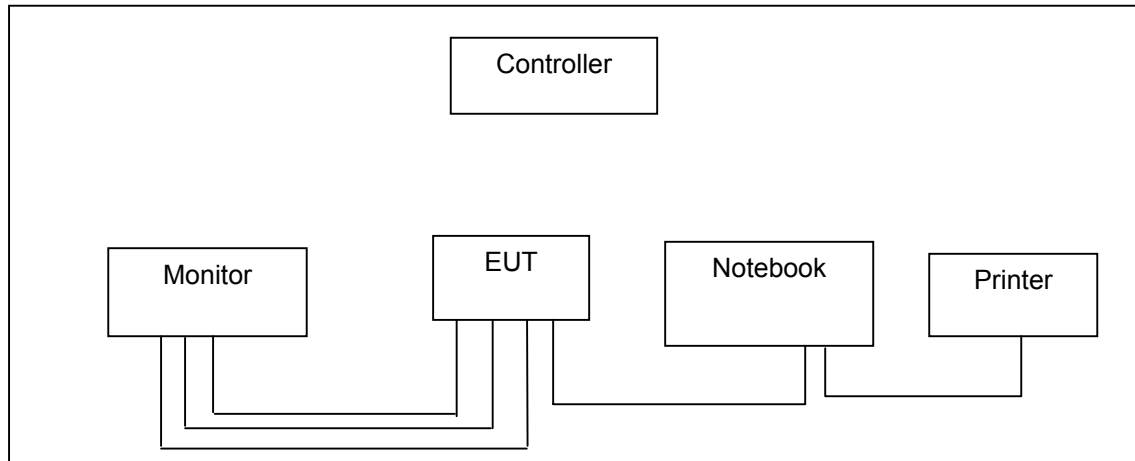

2.2. The Test Mode Description

For DSSS modulation, CCK is the worst case on all test items.

For OFDM modulation, BPSK is the worst case on all test items.

For OFDM modulation, turbo mode for channel 06 was executed in the test report.

Spurious emission below 1GHz is independent of channel selection, so only channel 11 with BPSK modulation was tested.

AC conduction emission is independent of channel selection, so only channel 11 with BPSK modulation was tested. There is 1 LAN port (RJ45) on the EUT, so there are 2 test modes for conduction testing, including LAN PORT link mode and WIRELESS link mode.

2.3. Description of Test Supporting Units

Support unit	Brand	Model No.	Serial No.	FCC ID	Data cable (m)
Notebook	COMPAQ	PRESARIO 1500	SP0004	DoC	-
Printer	EPSON	Stylus Color 680	SP0016	DoC	1.35
Trinitron Color Video	SONY	TVM-14L2	-	DoC	1.7



3. General Information of Test

3.1. Test Facility

Test Site Location : No. 52, Hwa Ya 1st Rd., Hwa Ya Technology Park, Kwei-Shan Hsiag, Tao Yuan Hsien, Taiwan, R.O.C.
TEL 886-3-327-3456
FAX 886-3-318-0055

Test Site No : CO04-HY / 03CH03-HY / TH01-HY

3.2. Test Conditions

Normal Voltage : 110.00V (power adapter)
Extreme Voltages : 100~240 V (power adapter)
Normal Temperature : 20°C
Extreme Temperature : -10 °C and 55 °C

3.3. Standards for Methods of Measurement

Here is the list of the standards followed in this test report.

ANSI C63.4-2003
47 CFR Part 15 Subpart C (Section 15.247)

3.4. DoC Statement

This EUT is also classified as a device of computer peripheral Class B which DoC has to be followed. It has been verified according to the rule of 47 CFR part 15 Subpart B, and found that all the requirements has been fulfilled.

3.5. Frequency Range Investigated

Radiated emission test: from 30 MHz to 10th carrier harmonic

3.6. Test Distance

The test distance of radiated emission (30MHz~1GHz) test from antenna to EUT is 3 M.
The test distance of radiated emission (1GHz~10th carrier harmonic) test from antenna to EUT is 3 M.

3.7. Test Software

During testing, Channel & Power Controlling Software: This was provided by the manufacturer and is able to let the test engineer select the operating channel as well as the RF output power. The parameters for channel selection is trying to offer the test engineer the ability to fix the operating channel for testing, both normal data and continuously transmitting modes are allowed, and that for RF output power selection is for the setting of RF output power expected by the customer and is going to be fixed on the firmware of the final end product.



4. List of Measurements

4.1. Summary of the Test Results

Applied Standard: 47 CFR Part 15 and Part 2			
Paragraph	FCC Rule	Description of Test	Result
5.1	15.247	6dB Spectrum Bandwidth	Pass
5.2	15.247	Maximum Conducted Output Power	Pass
5.3	15.247	Peak Power Spectral Density	Pass
5.4	15.247	Band Edges Emission	Pass
0	15.207	AC Power Line Conducted Emission	Pass
5.6	15.209/15.247	Spurious Radiated Emission	Pass
5.7	15.203/15.247	Antenna Requirement	Pass
5.8	2.1091	Maximum Permissible Exposure	Pass

5. Test Result

5.1. Test of 6dB Spectrum Bandwidth

5.1.1. Measuring Instruments

Item 18 of the table is on section 6.

5.1.2. Test Procedures

1. The transmitter output was connected to the spectrum analyzer through an attenuator.
2. Set RBW of spectrum analyzer to 100KHz and VBW to 100KHz.
3. The spectrum width with level higher than 6dB below the peak level.
4. Repeat above 1~3 points for the middle and highest channel of the EUT.

5.1.3. Test Setup Layout

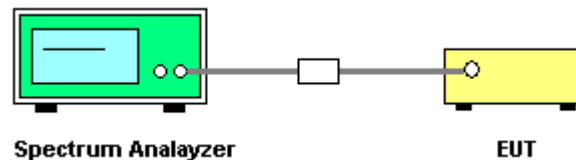

5.1.4. Test Result: See spectrum analyzer plots below

- Temperature: 23°C
- Relative Humidity: 51%
- Duty Cycle of the Equipment During the Test: 100.00%
- Test Engineer: Sam Lee

Modulation Type	Channel No.	Frequency (MHz)	6dB Bandwidth (MHz)	Min. Limit (MHz)
11b CCK	01	2412 MHz	11.76	0.5
11b CCK	06	2437 MHz	12.00	0.5
11b CCK	11	2462 MHz	12.00	0.5
11g BPSK	01	2412 MHz	16.44	0.5
11g BPSK	06	2437 MHz	16.40	0.5
11g BPSK	11	2462 MHz	16.44	0.5

Test Mode: Turbo Mode

Modulation Type	Channel No.	Frequency (MHz)	6dB Bandwidth (MHz)	Min. Limit (MHz)
BPSK	06	2437 MHz	31.44	0.5



Modulation Type: CCK (Channel 01) :

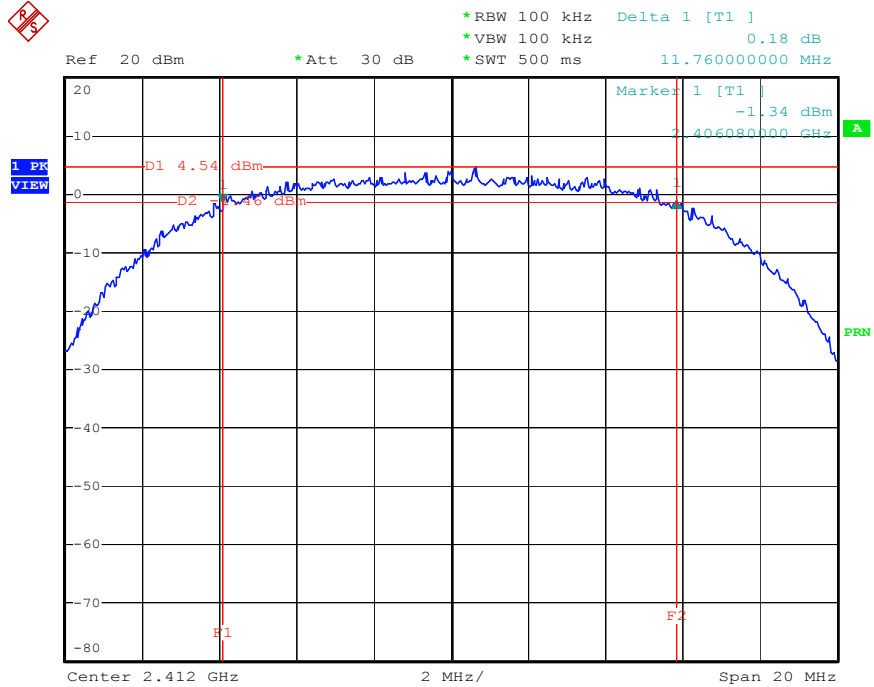

Date: 16.DEC.2004 20:53:44

Modulation Type: CCK (Channel 06) :

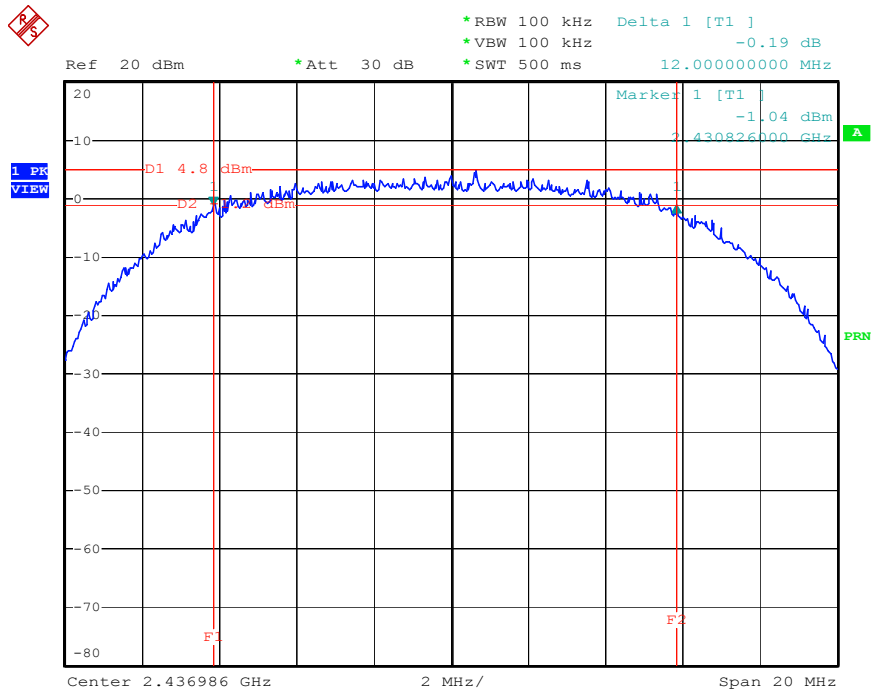

Date: 16.DEC.2004 21:00:00



Modulation Type: CCK (Channel 11) :

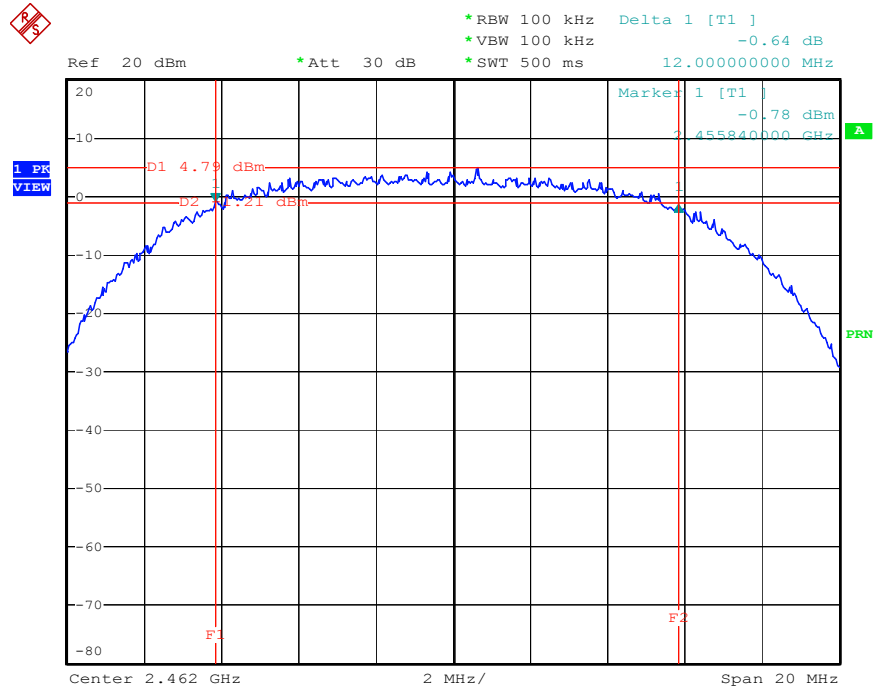



Modulation Type: BPSK (Channel 01) :

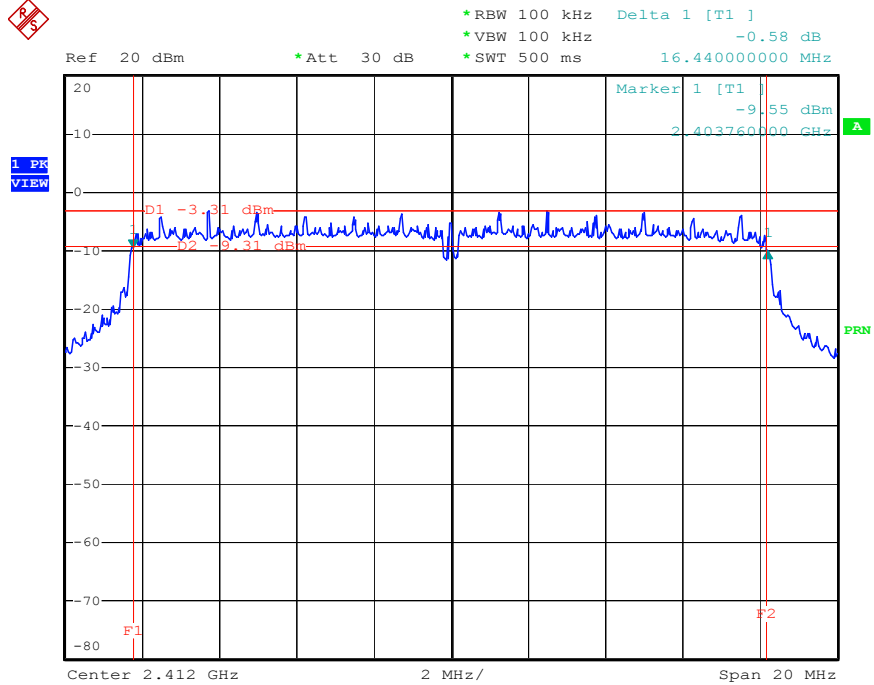

Date: 16.DEC.2004 21:21:19

Modulation Type: BPSK (Channel 06) :

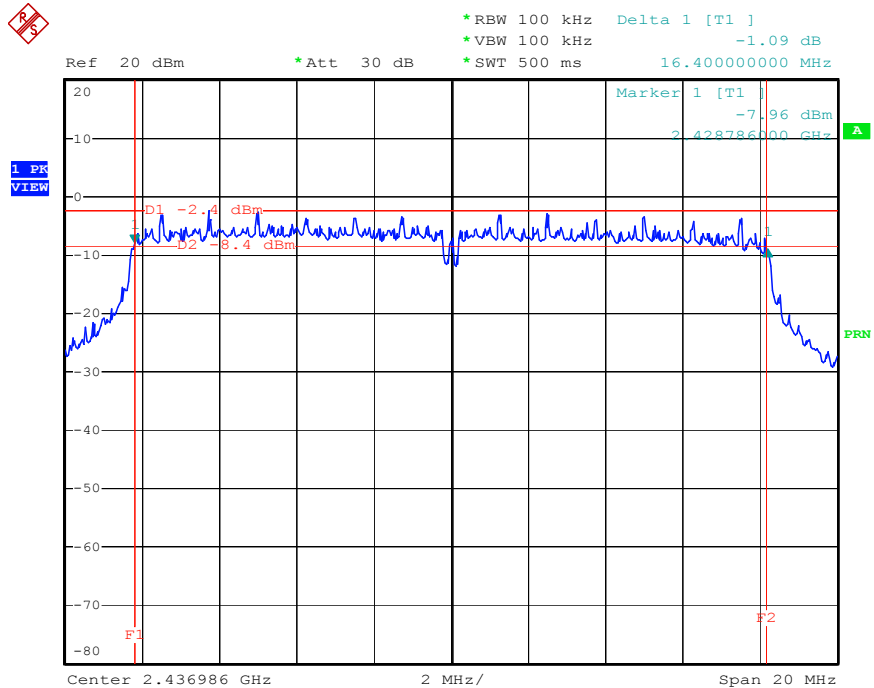

Date: 16.DEC.2004 21:27:03



Modulation Type: BPSK (Channel 11) :

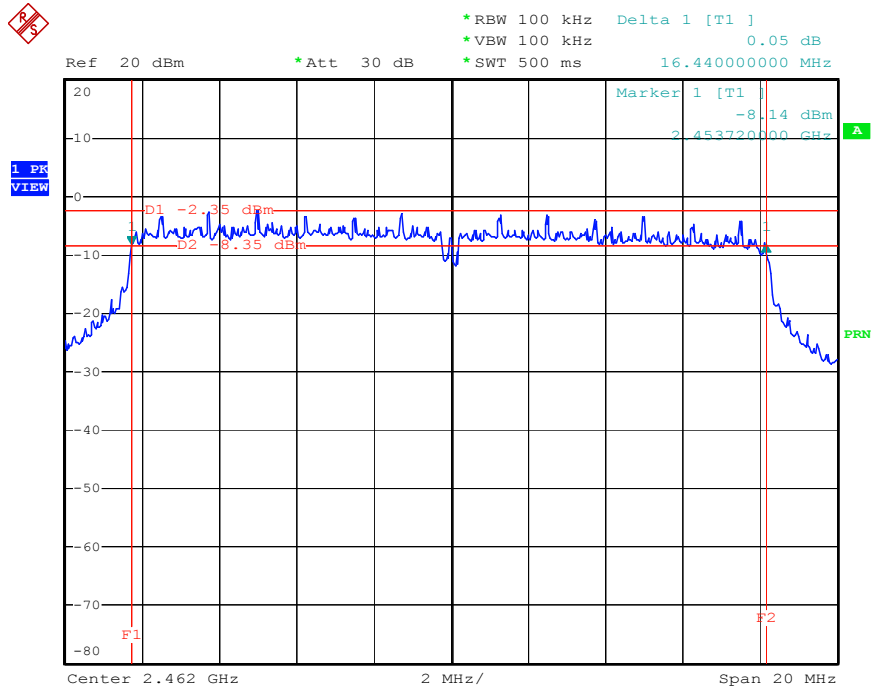

Date: 16.DEC.2004 21:28:56

Turbo Mode- Modulation Type: BPSK (Channel 06) :

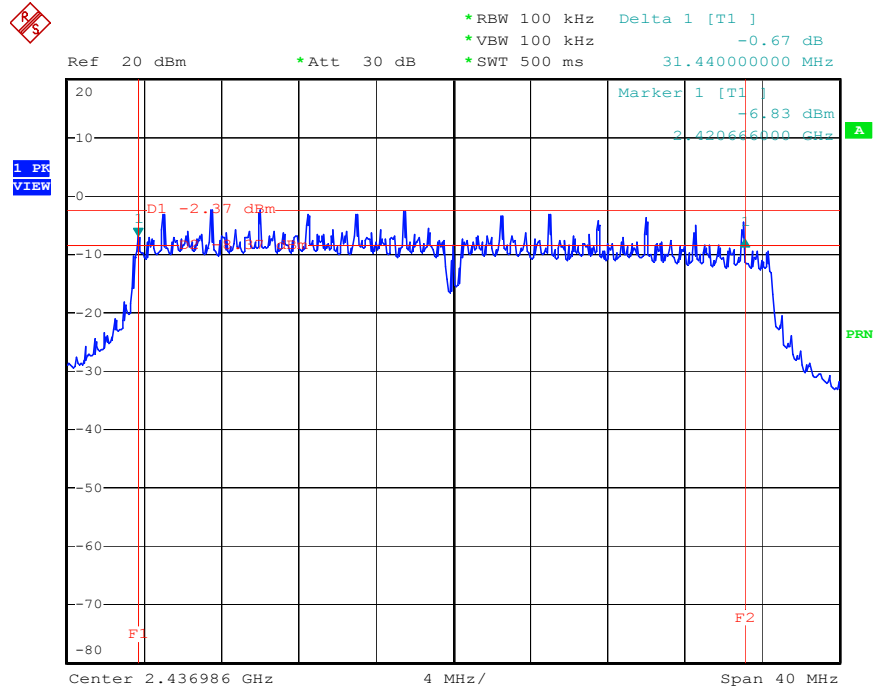

Date: 16.DEC.2004 21:44:16

5.2. Test of Maximum Conducted Output Power

5.2.1. Measuring Instruments

Item 18 of the table is on section 6.

5.2.2. Test Procedures

1. According to FCC DA 02-2138 test procedure, EUT connected to spectrum analyzer. Then used the channel power function of spectrum analyzer and calculated total average power with more than 26dB bandwidth.
2. Repeated the 1 for the middle and highest channel of the EUT.

5.2.3. Test Setup Layout

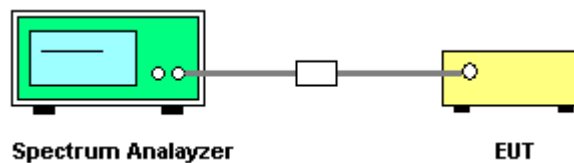

5.2.4. Test Result of Conducted Power

- Temperature: 23°C
- Relative Humidity: 51%
- Duty Cycle of the Equipment During the Test: 100.00%
- Test Engineer: Sam Lee

Modulation Type	Channel No.	Frequency (MHz)	Output Power (dBm)	Limits (dBm)
11b CCK	01	2412 MHz	16.40	30
11b CCK	06	2437 MHz	16.70	30
11b CCK	11	2462 MHz	16.60	30
11g BPSK	01	2412 MHz	17.10	30
11g BPSK	06	2437 MHz	17.20	30
11g BPSK	11	2462 MHz	17.10	30

The max output power : CCK modulation is 17.10 dBm. BPSK modulation is 17.20 dBm.

Test Mode: Turbo Mode

Modulation Type	Channel No.	Frequency (MHz)	Output Power (dBm)	Limits (dBm)
BPSK	06	2437 MHz	16.40	30



5.2.5. Test Result of EIRP Power

- Temperature: 23°C
- Relative Humidity: 51%
- Duty Cycle of the Equipment During the Test: 100.00%
- Test Engineer: Sam Lee

Antenna No.	Gain (dBi)	Modulation Type	Channel No.	Frequency (MHz)	Power (dBm)	Limits (dBm)
1	2.00	11b CCK	01	2412 MHz	18.40	36
1	2.00	11b CCK	06	2437 MHz	18.70	36
1	2.00	11b CCK	11	2462 MHz	18.60	36
1	2.00	11g BPSK	01	2412 MHz	19.10	36
1	2.00	11g BPSK	06	2437 MHz	19.20	36
1	2.00	11g BPSK	11	2462 MHz	19.10	36

Test Mode: Turbo Mode

Antenna No.	Gain (dBi)	Modulation Type	Channel No.	Frequency (MHz)	Power (dBm)	Limits (dBm)
1	2.00	BPSK	01	2437 MHz	18.40	36

5.3. Test of Peak Power Spectral Density

5.3.1. Measuring Instruments

Item 18 of the table is on section 6.

5.3.2. Test Procedures

1. The transmitter output is connected to the spectrum analyzer through an attenuator.
2. Set RBW of spectrum analyzer to 3kHz and VBW to 30kHz.
3. Mark the frequency with maximum peak power as the center of the display of the spectrum
4. Set the span to 1.5MHz and the sweep time to 500s and record the maximum peak value.
5. Repeated the 1~4 for the middle and highest channel of the EUT.

5.3.3. Test Setup Layout

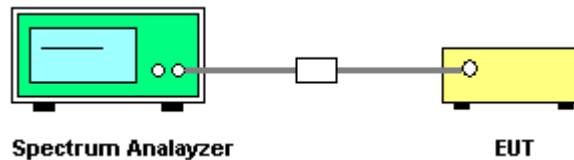

5.3.4. Test Result: See spectrum analyzer plots below

- Temperature: 23°C
- Relative Humidity: 51%
- Duty Cycle of the Equipment During the Test: 100.00%
- Test Engineer: Sam Lee

Modulation Type	Channel No.	Frequency (MHz)	Power Density (dBm)	Limits (dBm)
11b CCK	01	2412 MHz	-6.59	8
11b CCK	06	2437 MHz	-5.73	8
11b CCK	11	2462 MHz	-6.52	8
11g BPSK	01	2412 MHz	-8.38	8
11g BPSK	06	2437 MHz	-11.38	8
11g BPSK	11	2462 MHz	-11.62	8

Test Mode: Turbo Mode

Modulation Type	Channel No.	Frequency (MHz)	Power Density (dBm)	Limits (dBm)
BPSK	06	2437 MHz	-11062	8



Modulation Type: CCK (Channel 01) :

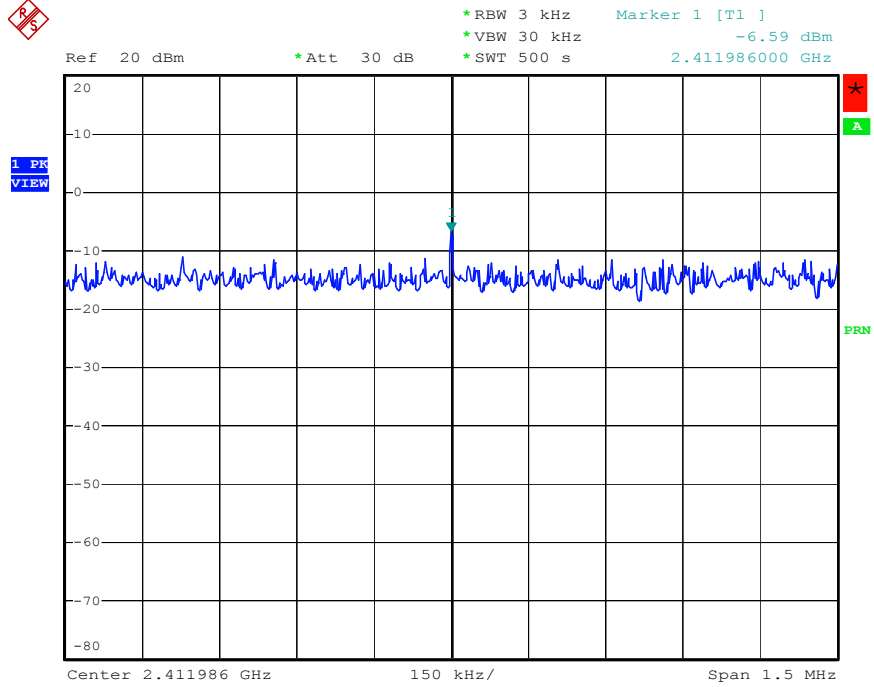

Date: 16.DEC.2004 20:56:16

Modulation Type: CCK (Channel 06) :

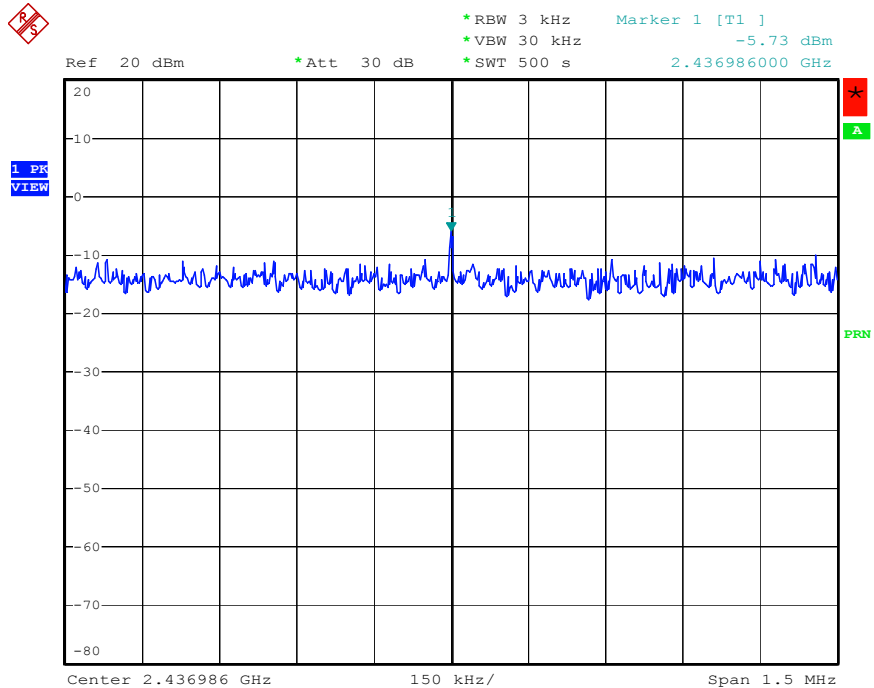

Date: 16.DEC.2004 20:58:31



Modulation Type: CCK (Channel 11) :

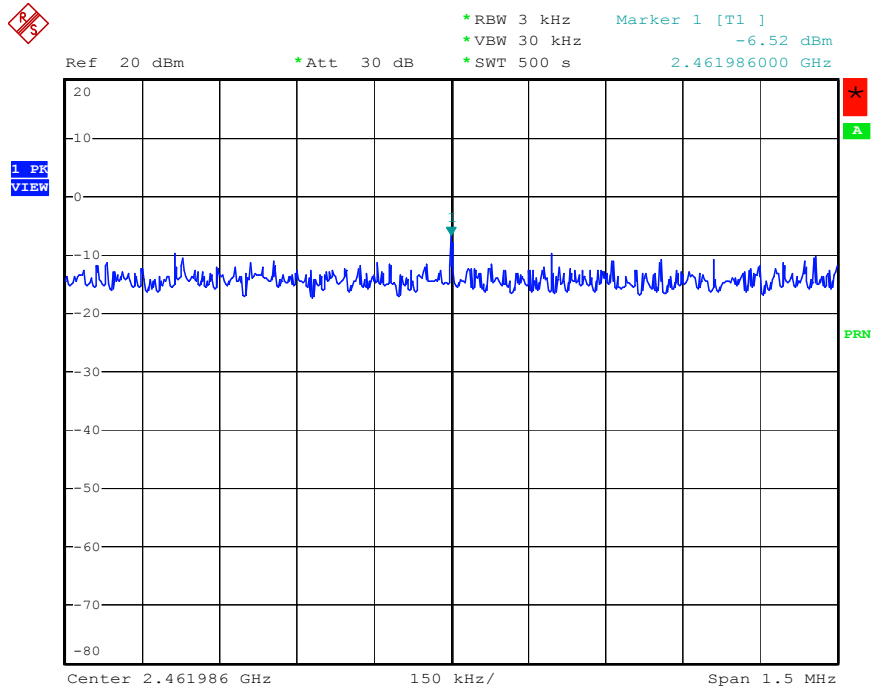

Date: 16.DEC.2004 21:05:58



Modulation Type: BPSK (Channel 01) :

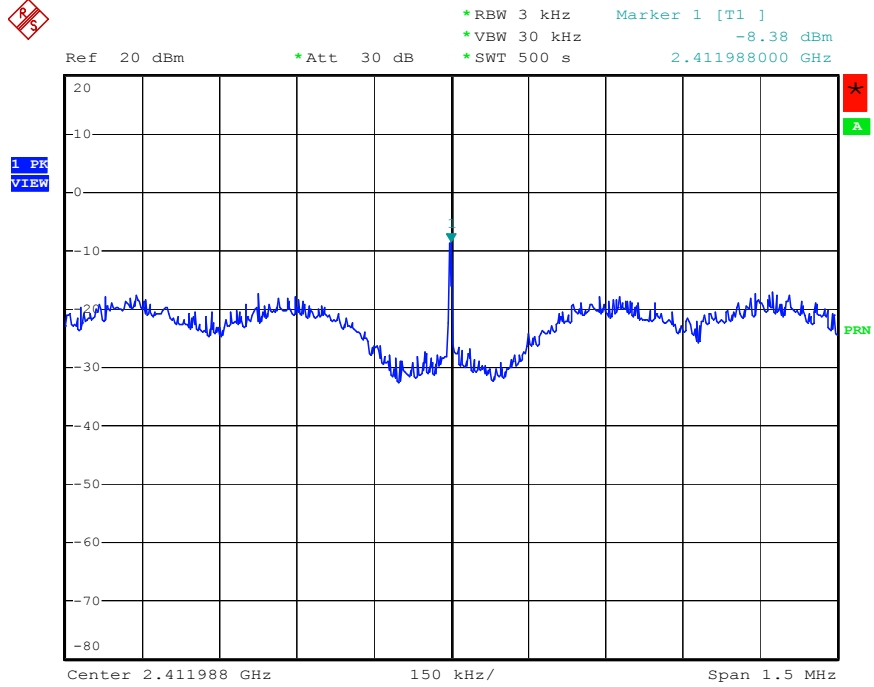

Date: 16.DEC.2004 21:22:32

Modulation Type: BPSK (Channel 06) :

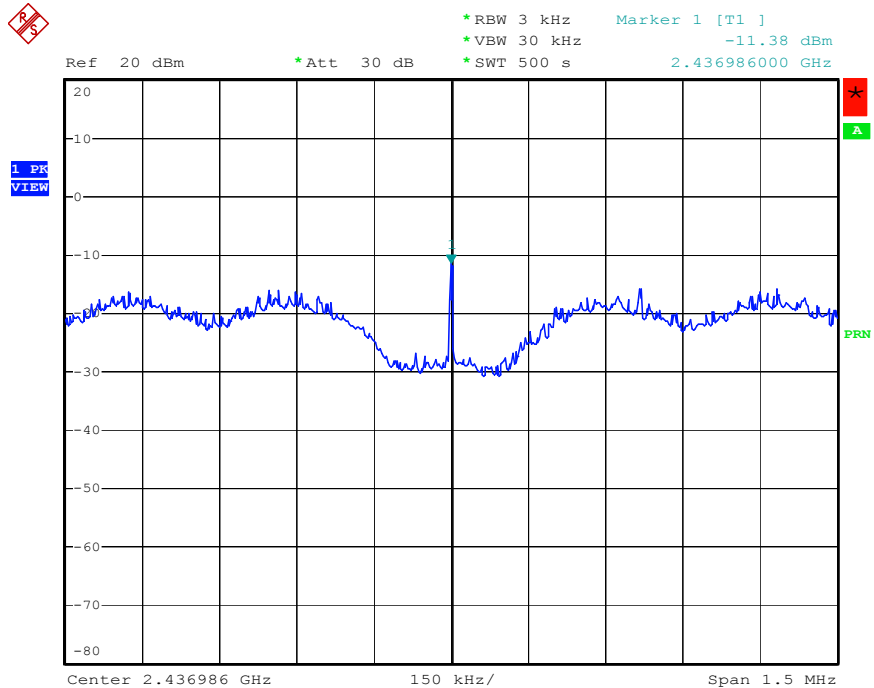

Date: 16.DEC.2004 21:25:39



Modulation Type: BPSK (Channel 11) :

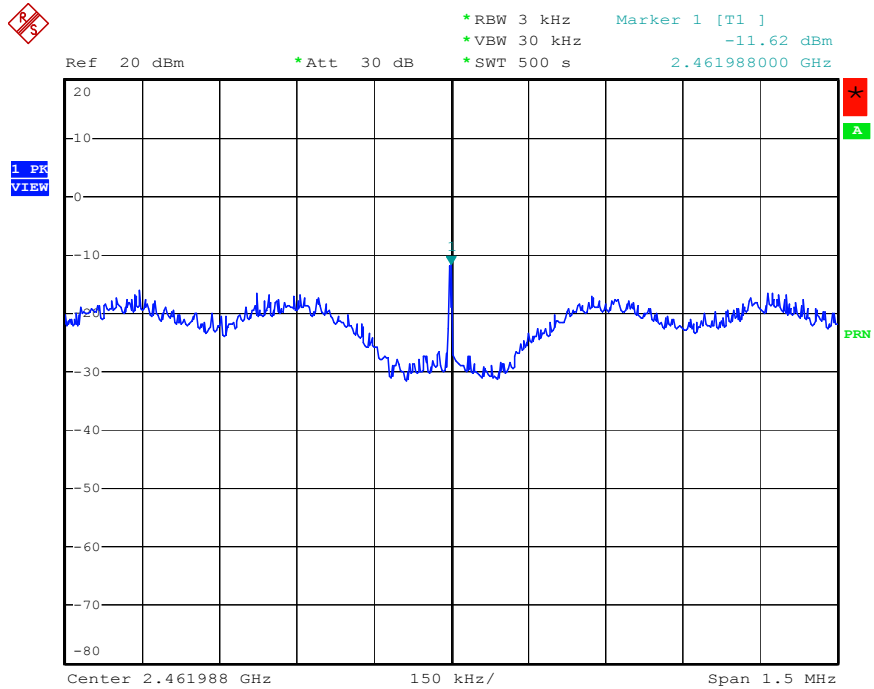

Date: 16.DEC.2004 21:32:14

Turbo Mode- Modulation Type: BPSK (Channel06) :

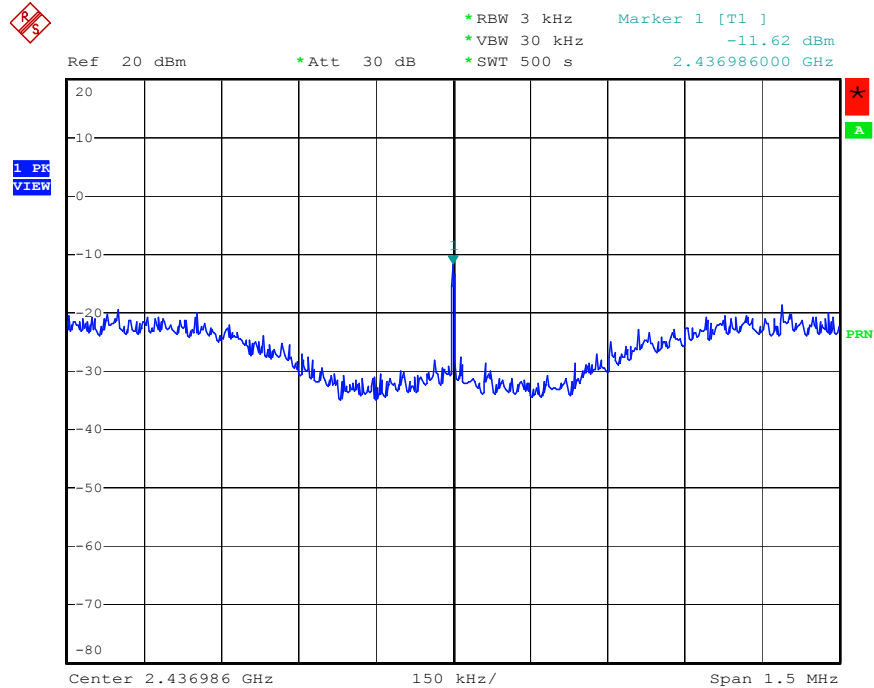

Date: 16.DEC.2004 21:42:21

5.4. Test of Band Edges Emission

5.4.1. Measuring Instruments

Item 6~18 of the table is on section 6.

5.4.2. Test Procedures

Conducted Measurement

1. The transmitter is set to the lowest channel.
2. The transmitter output was connected to the spectrum analyzer via a cable and cable loss is used as the offset of the spectrum analyzer.
3. Set both RBW and VBW of spectrum analyzer to 100KHz with convenient frequency span including 100MHz bandwidth from lower band edge.
4. The lowest band edges emission was measured and recorded.
5. The transmitter set to the highest channel and repeated 2~4.

Radiated Measurement

1. Configure the EUT according to ANSI C63.4.
2. The turn table was rotated by 360 degrees to determine the position of the highest radiation.
3. The height of the broadband receiving antenna was varied between one meter and four meters above ground to find the maximum emission field strength of both horizontal and vertical polarization.
4. For band edge emission, the antenna tower was scan (from 1 M to 4 M) and then the turn table was rotated (from 0 degree to 360 degrees) to find the maximum reading.
5. For band edge emission, use 10Hz VBW and 1MHz RBW for reading under AV and use 1MHz VBW and 1 MHz RBW for reading under PK.

5.4.3. Test Setup

Radiated Method

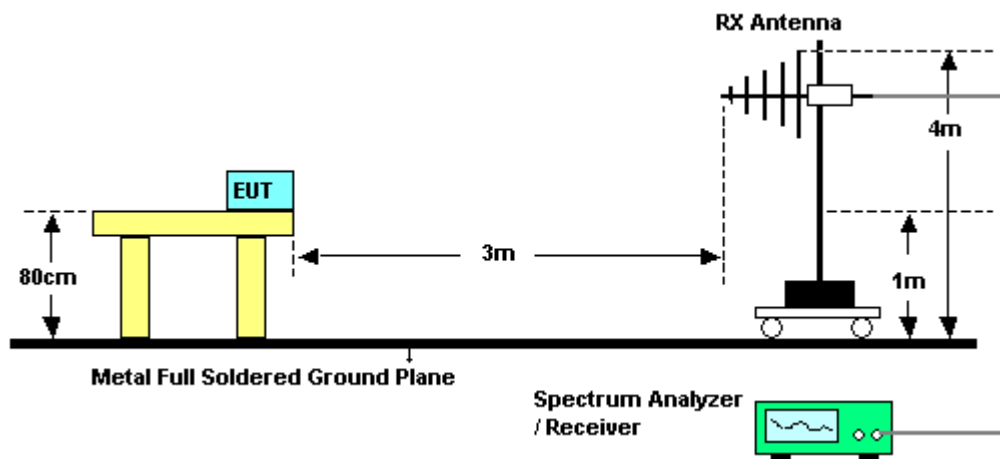

Conducted Method

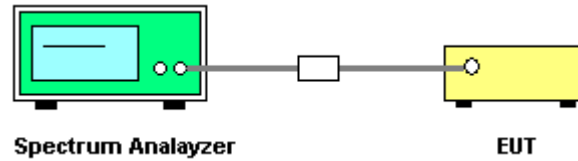

5.4.4. Test Result

Temperature: 23°C

Relative Humidity: 51%

Duty Cycle of the Equipment During the Test: 100.00%

Test Engineer: Sam Lee

Modulation Type	Test Channel	Freq. (MHz)	Level* (dBuV/m)	Margin (dB)	Limit (dBuV/m)	Trace (PK/AV)
11b CCK	01	2359.78	60.23	-13.77	74	PK
11b CCK	01	2359.78	51.7	-2.30	54	AV
11b CCK	11	2483.66	55.2	-18.80	74	PK
11b CCK	11	2483.66	43.75	-10.25	54	AV
11g BPSK	01	2384.86	66.09	-7.91	74	PK
11g BPSK	01	2384.86	46.88	-7.12	54	AV
11g BPSK	11	2483.85	57.29	-16.71	74	PK
11g BPSK	11	2483.85	43.27	-10.73	54	AV

Level* : The max field strength in the restricted bands.

Test Mode: Turbo Mode

Modulation Type	Test Channel	Freq. (MHz)	Level* (dBuV/m)	Margin (dB)	Limit (dBuV/m)	Trace (PK/AV)
BPSK	06	2387.90	63.27	-10.73	74	PK
BPSK	06	2387.90	45.83	-8.17	54	AV
BPSK	06	2486.89	55.24	-18.76	74	PK
BPSK	06	2486.89	43.09	-10.91	54	AV



Modulation Type: CCK (Channel 01) :

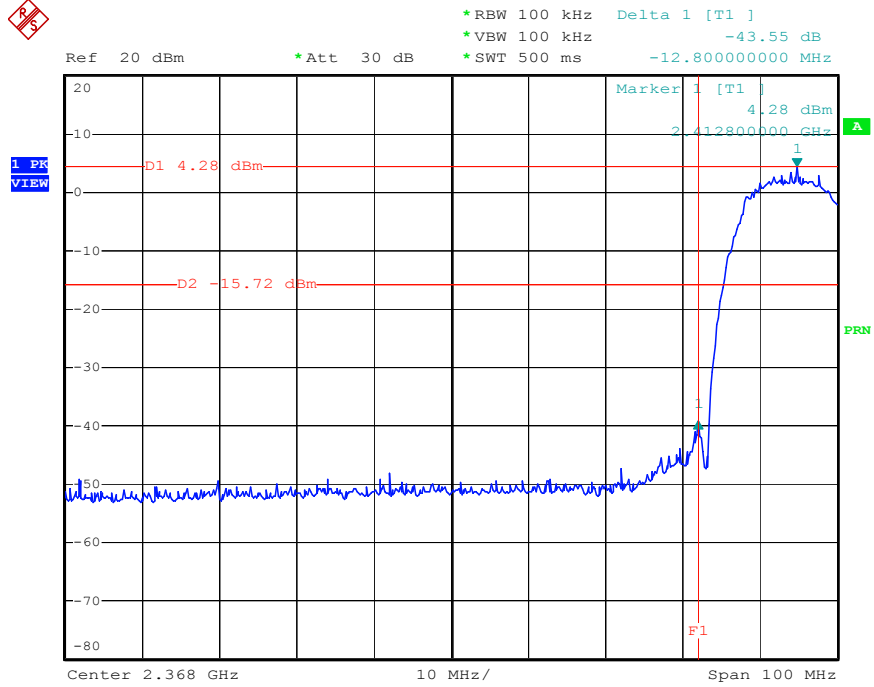

Date: 16.DEC.2004 20:54:56

Modulation Type: CCK (Channel 11) :

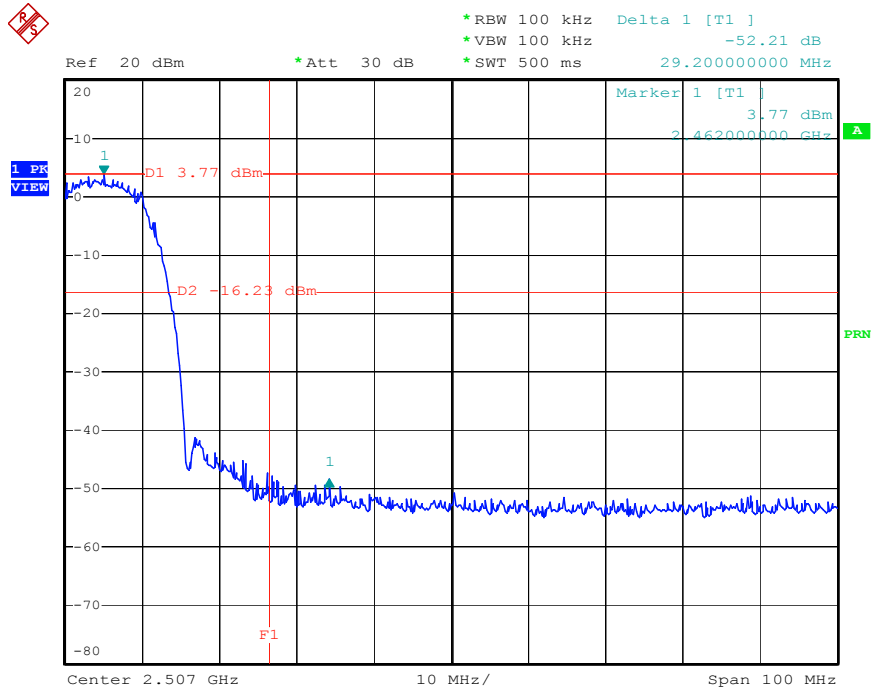

Date: 16.DEC.2004 21:04:50



Modulation Type: BPSK (Channel 01) :

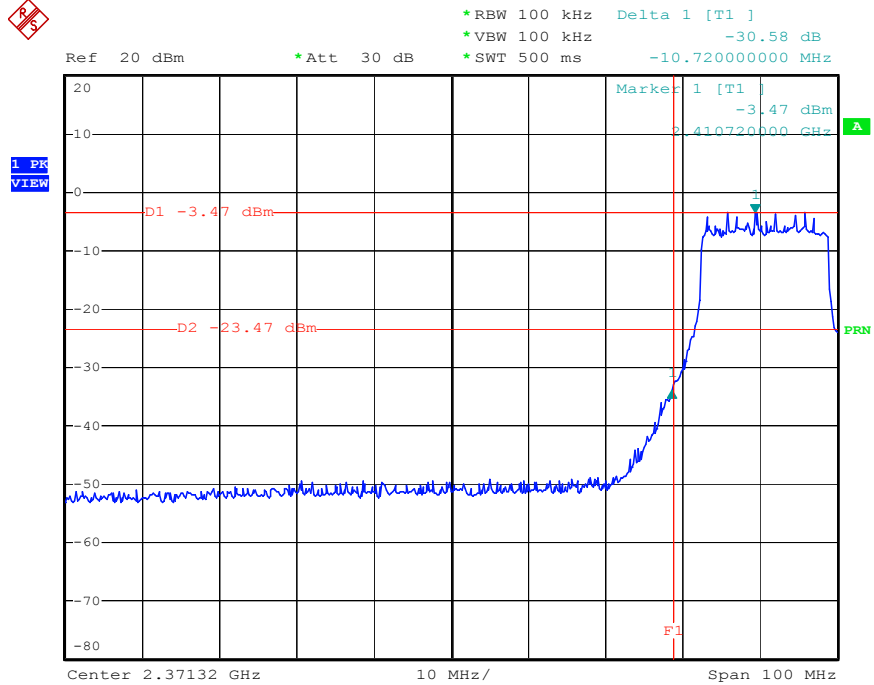

Date: 16.DEC.2004 21:19:26

Modulation Type: BPSK (Channel 11) :

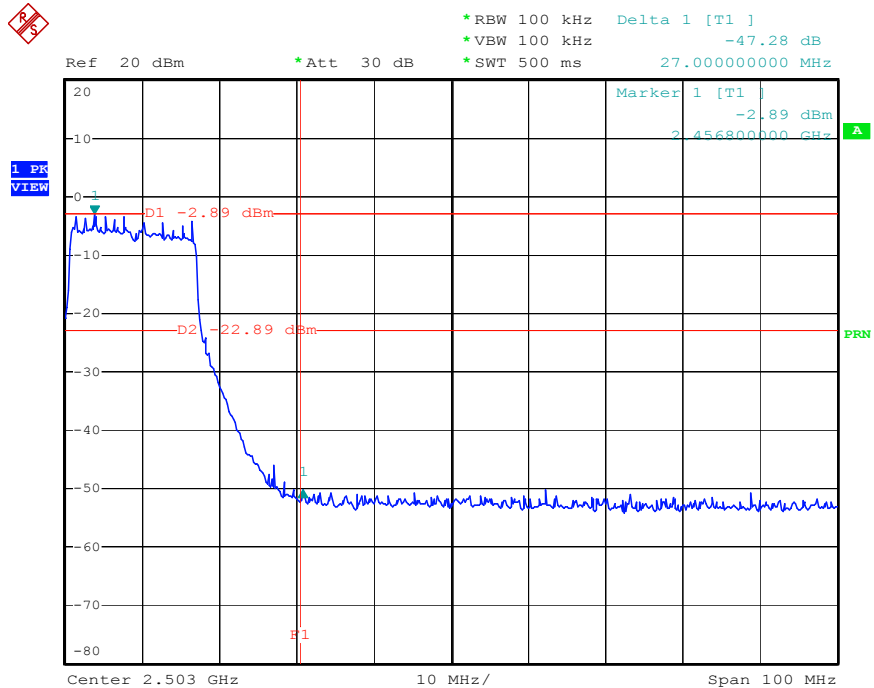

Date: 16.DEC.2004 21:30:50



Turbo Mode- Modulation Type: BPSK (Channel 06) :

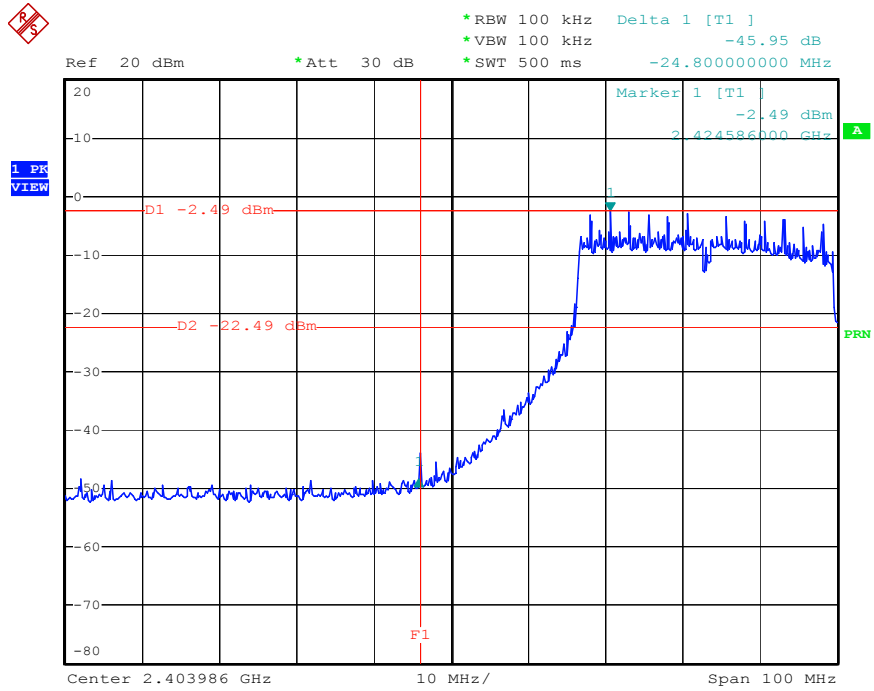

Date: 16.DEC.2004 21:45:30

Turbo Mode- Modulation Type: BPSK (Channel 06) :

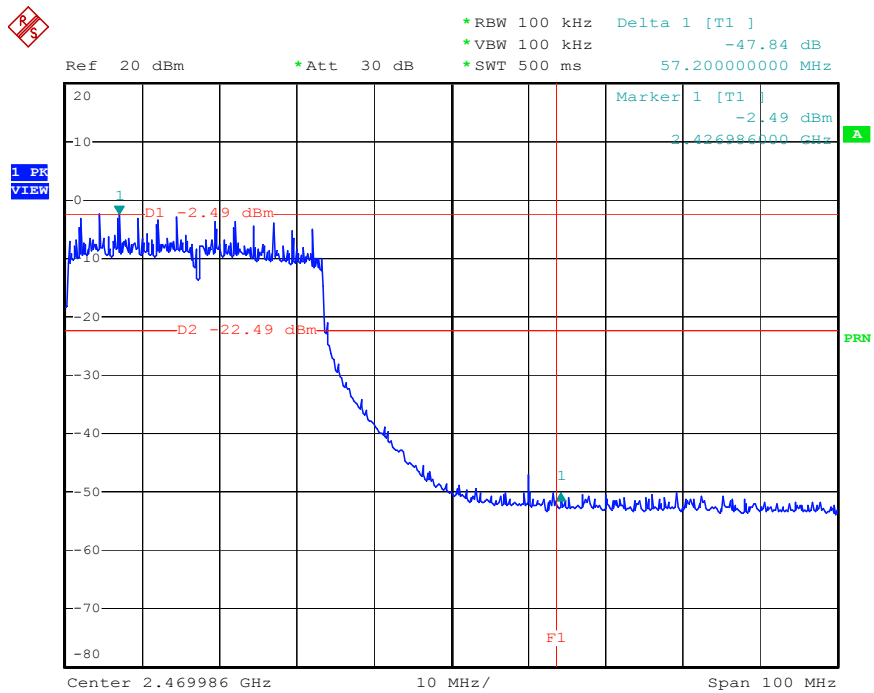

Date: 16.DEC.2004 21:46:21

5.5. Test of AC Power Line Conducted Emission

5.5.1. Measuring Instruments

Please reference item 1~5 in chapter 6 for the instruments used for testing.

5.5.2. Test Procedures

1. Configure the EUT according to ANSI C63.4.
2. The EUT has to be placed 0.4 meter far from the conducting wall of the shielding room and at least 80 centimeters from any other grounded conducting surface.
3. Connect EUT to the power mains through a line impedance stabilization network (LISN)
4. All the support units are connected to the other LISNs. The LISN should provides 50uH/50ohms coupling impedance.
5. The frequency range from 150 KHz to 30 MHz was searched.
6. Use the Channel & Power Controlling software to make the EUT working on selected channel and expected output power, then use the "H" Patter Generator software to make the supporting equipments stay on working condition.
7. Set the test-receiver system to Peak Detect Function and Specified Bandwidth with Maximum Hold Mode.
8. The measurement has to be done between each power line and ground at the power terminal for each RF channel. Only one RF channel has to be investigated since this test is independent with the RF channel selection.

5.5.3. Test Setup Layout

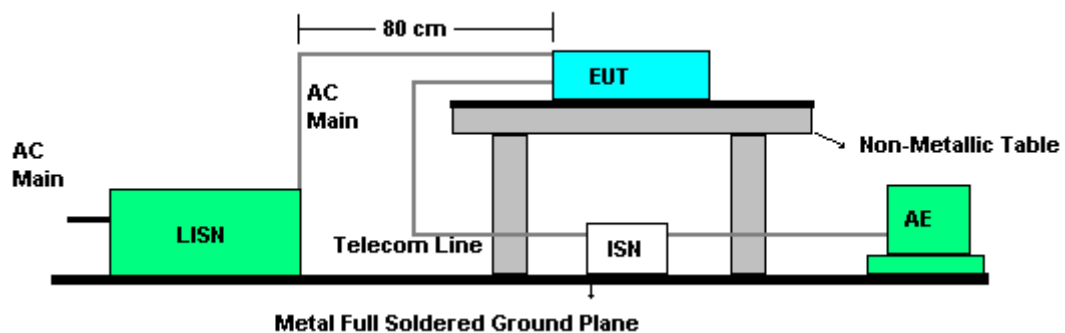



5.5.4. Test Result of Conducted Emission

- Test Mode: LAN PORT
- Temperature: 23°C
- Relative Humidity: 51%
- Test Engineer: Sky Wu

Line to Ground

Frequency (MHz)	Level (dBUV)	Over Limit (dB)	Limit Line (dBUV)	Read Level (dBUV)	LISN Factor (dB)	Cable Loss (dB)	Remark
0.21	42.26	-20.60	62	42.13	0.1	0.03	QP
0.21	39.38	-13.48	52	39.25	0.1	0.03	Average
0.54	33.99	-22.01	56	33.74	0.1	0.15	QP
0.54	26.34	-19.66	46	26.09	0.1	0.15	Average
0.99	32.15	-23.85	56	31.61	0.1	0.44	QP
0.99	20.77	-25.23	46	20.23	0.1	0.44	Average
1.86	33.52	-22.48	56	33.36	0.1	0.06	QP
1.86	15.86	-30.14	46	15.70	0.1	0.06	Average
12.80	43.53	-16.47	60	42.49	0.2	0.84	QP
12.80	43.00	-7.00	50	41.96	0.2	0.84	Average
19.70	44.78	-15.22	60	44.27	0.3	0.21	QP
19.70	44.16	-5.84	50	43.65	0.3	0.21	Average



Neutral to Ground

Frequency (MHz)	Level (dBuV)	Over Limit (dB)	Limit Line (dBuV)	Read Level (dBuV)	LISN Factor (dB)	Cable Loss (dB)	Remark
0.22	40.73	-12.05	52	40.60	0.1	0.03	Average
0.22	45.57	-17.21	62	45.44	0.1	0.03	QP
0.54	31.62	-24.38	56	31.37	0.1	0.15	QP
0.54	23.13	-22.87	46	22.88	0.1	0.15	Average
0.87	20.80	-25.2	46	20.22	0.1	0.48	Average
0.87	34.05	-21.95	56	33.47	0.1	0.48	QP
1.21	34.69	-21.31	56	34.27	0.1	0.32	QP
1.21	21.58	-24.42	46	21.16	0.1	0.32	Average
12.80	43.81	-16.19	60	42.77	0.2	0.84	QP
12.80	43.21	-6.79	50	42.17	0.2	0.84	Average
17.69	47.67	-12.33	60	47.24	0.2	0.17	QP
17.69	47.34	-2.66	50	46.91	0.2	0.17	Average



- Test Mode: WIRELESS Link
- Temperature: 23°C
- Relative Humidity: 51%
- Test Engineer: Sky Wu

Line to Ground

Frequency (MHz)	Level (dBuV)	Over Limit (dB)	Limit Line (dBuV)	Read Level (dBuV)	LISN Factor (dB)	Cable Loss (dB)	Remark
0.22	40.23	-22.31	62	40.09	0.1	0.04	QP
0.22	37.54	-15.00	52	37.40	0.1	0.04	Average
0.45	33.73	-23.04	56	33.60	0.1	0.03	QP
0.45	27.42	-19.35	46	27.29	0.1	0.03	Average
1.24	37.42	-18.58	56	37.01	0.1	0.31	QP
1.24	23.76	-22.24	46	23.35	0.1	0.31	Average
1.60	33.13	-22.87	56	32.88	0.1	0.15	QP
1.60	16.45	-29.55	46	16.20	0.1	0.15	Average
7.89	31.63	-28.37	60	31.37	0.2	0.06	QP
7.89	16.71	-33.29	50	16.45	0.2	0.06	Average
21.26	25.91	-24.09	50	25.40	0.3	0.21	Average
21.26	34.7	-25.30	60	34.19	0.3	0.21	QP



Neutral to Ground

Frequency (MHz)	Level (dBuV)	Over Limit (dB)	Limit Line (dBuV)	Read Level (dBuV)	LISN Factor (dB)	Cable Loss (dB)	Remark
0.22	44.89	-17.63	62	44.75	0.1	0.04	QP
0.22	39.07	-13.45	52	38.93	0.1	0.04	Average
0.57	33.16	-22.84	56	32.84	0.1	0.22	QP
0.57	21.85	-24.15	46	21.53	0.1	0.22	Average
1.24	36.55	-19.45	56	36.14	0.1	0.31	QP
1.24	22.90	-23.10	46	22.49	0.1	0.31	Average
7.61	31.50	-28.5	60	31.27	0.1	0.06	QP
7.61	14.92	-35.08	50	14.69	0.1	0.06	Average
13.13	34.04	-25.96	60	32.96	0.2	0.88	QP
13.13	23.23	-26.77	50	22.15	0.2	0.88	Average
21.04	34.78	-25.22	60	34.24	0.3	0.21	QP
21.04	26.09	-23.91	50	25.55	0.3	0.21	Average

5.5.5. Photographs of Conducted Emission Test Configuration

LAN PORT

FRONT VIEW



REAR VIEW

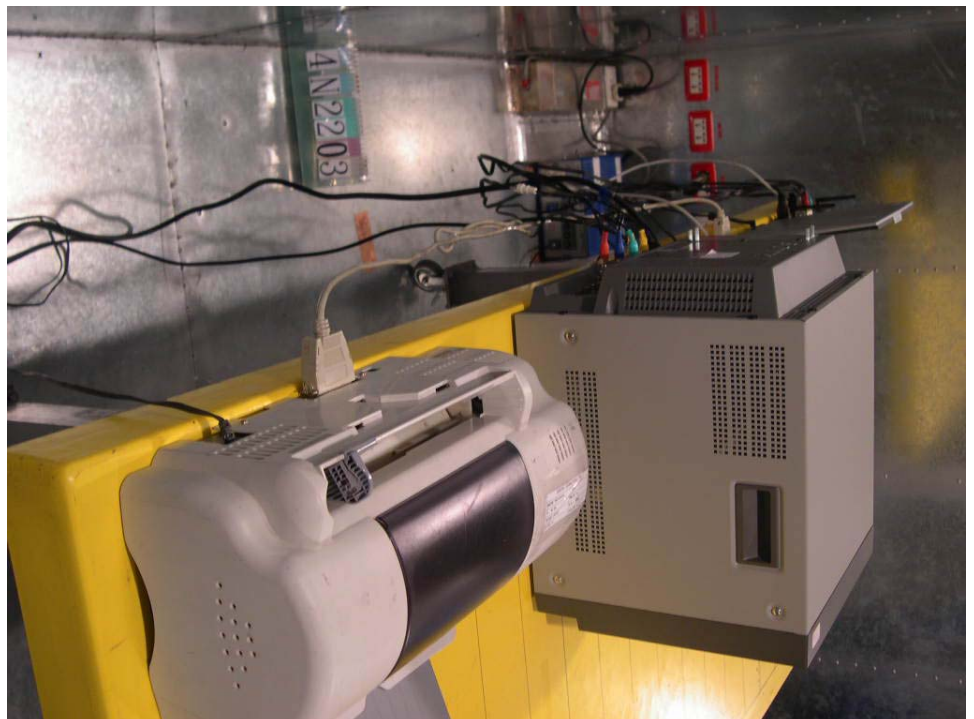

WIRELESS Link

FRONT VIEW



REAR VIEW



5.6. Test of Spurious Radiated Emission

5.6.1. Measuring Instruments

Please reference item 6~17 in chapter 6 for the instruments used for testing.

5.6.2. Test Procedures

1. Configure the EUT according to ANSI C63.4.
2. The EUT was placed on the top of the turn table 0.8 meter above ground.
3. The phase center of the receiving antenna mounted on the top of a height-variable antenna tower was placed 3 meters far away from the turn table.
4. Power on the EUT and all the supporting units.
5. The turn table was rotated by 360 degrees to determine the position of the highest radiation.
6. The height of the broadband receiving antenna was varied between one meter and four meters above ground to find the maximum emission field strength of both horizontal and vertical polarization.
7. For each suspected emission, the antenna tower was scan (from 1 M to 4 M) and then the turn table was rotated (from 0 degree to 360 degrees) to find the maximum reading.
8. Set the test-receiver system to Peak or CISPR quasi-peak Detect Function with specified bandwidth under Maximum Hold Mode.
9. For emission above 1GHz, use 1MHz VBW and RBW for peak reading. Then 1MHz RBW and 10Hz VBW for average reading in spectrum analyzer.
10. If the emission level of the EUT in peak mode was 3 dB lower than the average limit specified, then testing will be stopped and peak values of EUT will be reported, otherwise, the emissions which do not have 3 dB margin will be repeated one by one using the quasi-peak method for below 1GHz and average method for above the 1GHz. the reported.
11. For testing above 1GHz, the emission level of the EUT in peak mode was 20dB higher than average limit (that means the emission level in peak mode also complies with the limit in average mode), then testing will be stopped and peak values of EUT will be reported, otherwise, the emissions will be measured in average mode again and reported.

5.6.3. Test Setup Layout

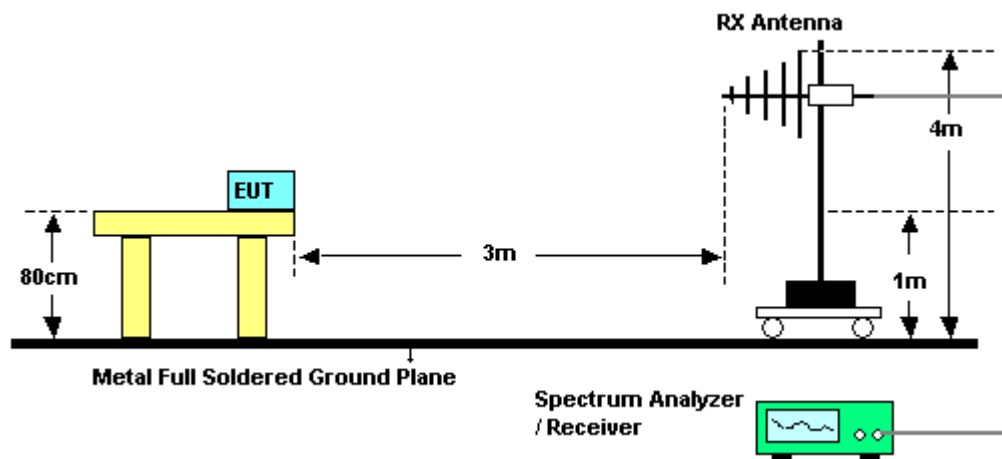



5.6.4. Test Results for CH 11 / 2462 MHz (for emission below 1GHz)

- Modulation Type: 11g BPSK
- Temperature: 23°C
- Relative Humidity: 51%
- Duty Cycle of the Equipment During the Test: 100.00%
- Test Engineer: Ted Chiu

(A) Polarization: Horizontal

	Freq	Level	Over Limit	Limit Line	Read Level	Probe Factor	Cable Loss	Preamp Factor	Remark	Ant Pos	Table Pos
	MHz	dBuV/m	dB	dBuV/m	dBuV	dB	dB	dB		cm	deg
1	44.790	27.36	-12.64	40.00	41.35	12.41	1.15	27.55	Peak	---	---
2	67.230	27.96	-12.04	40.00	44.05	9.99	1.38	27.46	Peak	---	---
3	143.220	27.08	-16.42	43.50	39.72	12.36	2.11	27.11	Peak	---	---
1	400.800	35.17	-10.83	46.00	42.61	16.79	3.47	27.70	Peak	---	---
2	700.800	34.17	-11.83	46.00	36.90	20.71	4.66	28.10	Peak	---	---
3	804.000	36.01	-9.99	46.00	36.67	21.89	5.13	27.68	Peak	---	---

(B) Polarization: Vertical

	Freq	Level	Over Limit	Limit Line	Read Level	Probe Factor	Cable Loss	Preamp Factor	Remark	Ant Pos	Table Pos
	MHz	dBuV/m	dB	dBuV/m	dBuV	dB	dB	dB		cm	deg
1 !	43.430	39.43	-0.57	40.00	53.38	12.46	1.13	27.54	QP	---	---
2 !	67.740	35.24	-4.76	40.00	51.35	9.96	1.39	27.46	QP	---	---
3 !	79.470	35.74	-4.26	40.00	52.04	9.52	1.54	27.36	Peak	---	---
1	400.800	34.51	-11.49	46.00	41.95	16.79	3.47	27.70	Peak	---	---
2	700.800	34.15	-11.85	46.00	36.88	20.71	4.66	28.10	Peak	---	---
3	804.000	35.85	-10.15	46.00	36.51	21.89	5.13	27.68	Peak	---	---

Note:

Emission level (dBuV/m) = 20 log Emission level (uV/m)

Corrected Reading: Probe Factor + Cable Loss + Read Level - Preamp Factor = Level



5.6.5. Test Results for CH 01 / 2412 MHz (for emission above 1GHz)

- Modulation Type: 11b CCK
- Temperature: 23°C
- Relative Humidity: 51%
- Duty Cycle of the Equipment During the Test: 100.00%
- Test Engineer: Ted Chiu

(A) Polarization: Horizontal

	Freq	Level	Over Limit	Limit Line	Read Level	Probe Factor	Cable Loss	Preamp Factor	Remark	Ant Pos	Table Pos
	MHz	dBuV/m	dB	dBuV/m	dBuV	dB	dB	dB		cm	deg
1	2688.000	49.46	-24.54	74.00	57.91	29.09	1.98	39.52	Peak	---	---
2	3972.000	43.24	-30.76	74.00	48.91	32.46	1.28	39.41	Peak	---	---
3	7648.000	50.73	-23.27	74.00	50.20	36.75	3.13	39.35	Peak	---	---

(B) Polarization: Vertical

	Freq	Level	Over Limit	Limit Line	Read Level	Probe Factor	Cable Loss	Preamp Factor	Remark	Ant Pos	Table Pos
	MHz	dBuV/m	dB	dBuV/m	dBuV	dB	dB	dB		cm	deg
1	2688.000	54.73	-19.27	74.00	63.18	29.09	1.98	39.52	Peak	---	---
2	2688.000	50.70	-3.30	54.00	59.15	29.09	1.98	39.52	Average	---	---
3	3968.000	43.25	-30.75	74.00	48.92	32.46	1.28	39.41	Peak	---	---
4	7156.000	47.50	-26.50	74.00	48.67	35.51	2.82	39.50	Peak	---	---

Note:

Emission level (dBuV/m) = 20 log Emission level (uV/m)

Corrected Reading: Probe Factor + Cable Loss + Read Level - Preamp Factor = Level



- Modulation Type: 11g BPSK
- Temperature: 23°C
- Relative Humidity: 51%
- Duty Cycle of the Equipment During the Test: 100.00%
- Test Engineer: Ted Chiu

(A) Polarization: Horizontal

	Freq	Level	Over Limit	Limit Line	Read Level	Probe Factor	Cable Loss	Preamp Factor	Remark	Ant Pos	Table Pos
	MHz	dBuV/m	dB	dBuV/m	dBuV	dB	dB	dB		cm	deg
1	2688.000	48.83	-25.17	74.00	57.28	29.09	1.98	39.52	Peak	---	---
2	3712.000	43.94	-30.06	74.00	49.57	31.78	1.73	39.14	Peak	---	---
3	7704.000	48.65	-25.35	74.00	48.16	36.80	3.03	39.34	Peak	---	---

(B) Polarization: Vertical

	Freq	Level	Over Limit	Limit Line	Read Level	Probe Factor	Cable Loss	Preamp Factor	Remark	Ant Pos	Table Pos
	MHz	dBuV/m	dB	dBuV/m	dBuV	dB	dB	dB		cm	deg
1	2688.000	53.34	-20.66	74.00	61.79	29.09	1.98	39.52	Peak	---	---
2	2688.000	52.82	-1.18	54.00	61.27	29.09	1.98	39.52	Average	---	---
3	4828.000	45.56	-28.44	74.00	50.21	33.02	2.47	40.14	Peak	---	---
4	7336.000	47.72	-26.28	74.00	48.07	36.13	2.97	39.45	Peak	---	---

Note:

Emission level (dBuV/m) = 20 log Emission level (uV/m)

Corrected Reading: Probe Factor + Cable Loss + Read Level - Preamp Factor = Level



5.6.6. Test Results for CH 06 / 2437 MHz (for emission above 1GHz)

- Modulation Type: 11b CCK
- Temperature: 23°C
- Relative Humidity: 51%
- Duty Cycle of the Equipment During the Test: 100.00%
- Test Engineer: Ted Chiu

(A) Polarization: Horizontal

	Freq	Level	Over Limit	Limit Line	Read Level	Probe Factor	Cable Loss	Preamp Factor	Remark	Ant Pos	Table Pos
	MHz	dBuV/m	dB	dBuV/m	dBuV	dB	dB	dB		cm	deg
1	2688.000	48.26	-25.74	74.00	56.71	29.09	1.98	39.52	Peak	---	---
2	3924.000	42.01	-31.99	74.00	48.86	32.32	0.19	39.36	Peak	---	---
3	7172.000	46.88	-27.12	74.00	48.05	35.62	2.71	39.50	Peak	---	---

(B) Polarization: Vertical

	Freq	Level	Over Limit	Limit Line	Read Level	Probe Factor	Cable Loss	Preamp Factor	Remark	Ant Pos	Table Pos
	MHz	dBuV/m	dB	dBuV/m	dBuV	dB	dB	dB		cm	deg
1	2688.000	53.98	-20.02	74.00	62.43	29.09	1.98	39.52	Peak	---	---
2	2688.000	50.99	-3.01	54.00	59.44	29.09	1.98	39.52	Average	---	---
3	3968.000	43.30	-30.70	74.00	48.97	32.46	1.28	39.41	Peak	---	---
4	7604.000	49.61	-24.39	74.00	49.32	36.70	2.96	39.37	Peak	---	---

Note:

Emission level (dBuV/m) = 20 log Emission level (uV/m)

Corrected Reading: Probe Factor + Cable Loss + Read Level - Preamp Factor = Level



- Modulation Type: 11g BPSK
- Temperature: 23°C
- Relative Humidity: 51%
- Duty Cycle of the Equipment During the Test: 100.00%
- Test Engineer: Ted Chiu

(A) Polarization: Horizontal

	Freq	Level	Over Limit	Limit Line	Read Level	Probe Factor	Cable Loss	Preamp Factor	Remark	Ant Pos	Table Pos
	MHz	dBuV/m	dB	dBuV/m	dBuV	dB	dB	dB		cm	deg
1	2688.000	48.70	-25.30	74.00	57.15	29.09	1.98	39.52	Peak	---	---
2	3972.000	43.42	-30.58	74.00	49.09	32.46	1.28	39.41	Peak	---	---
3	7640.000	49.17	-24.83	74.00	48.64	36.75	3.13	39.35	Peak	---	---

(B) Polarization: Vertical

	Freq	Level	Over Limit	Limit Line	Read Level	Probe Factor	Cable Loss	Preamp Factor	Remark	Ant Pos	Table Pos
	MHz	dBuV/m	dB	dBuV/m	dBuV	dB	dB	dB		cm	deg
1	2688.000	53.56	-20.44	74.00	62.01	29.09	1.98	39.52	Peak	---	---
2	2688.000	52.27	-1.73	54.00	60.72	29.09	1.98	39.52	Average	---	---
3	4876.000	47.58	-26.42	74.00	52.10	33.11	2.51	40.14	Peak	---	---
4	7112.000	47.16	-26.84	74.00	48.21	35.46	3.00	39.51	Peak	---	---

Note:

Emission level (dBuV/m) = 20 log Emission level (uV/m)

Corrected Reading: Probe Factor + Cable Loss + Read Level - Preamp Factor = Level



5.6.7. Test Results for CH 11 / 2462 MHz (for emission above 1GHz)

- Modulation Type: 11b CCK
- Temperature: 23°C
- Relative Humidity: 51%
- Duty Cycle of the Equipment During the Test: 100.00%
- Test Engineer: Ted Chiu

(A) Polarization: Horizontal

	Freq	Level	Over Limit	Limit Line	Read Level	Probe Factor	Cable Loss	Preamp Factor	Remark	Ant Pos	Table Pos
	MHz	dBuV/m	dB	dBuV/m	dBuV	dB	dB	dB		cm	deg
1	2688.000	48.25	-25.75	74.00	56.70	29.09	1.98	39.52	Peak	---	---
2	3980.000	43.64	-30.36	74.00	49.31	32.46	1.28	39.41	Peak	---	---
3	7240.000	48.93	-25.07	74.00	49.74	35.82	2.84	39.47	Peak	---	---

(B) Polarization: Vertical

	Freq	Level	Over Limit	Limit Line	Read Level	Probe Factor	Cable Loss	Preamp Factor	Remark	Ant Pos	Table Pos
	MHz	dBuV/m	dB	dBuV/m	dBuV	dB	dB	dB		cm	deg
1	2688.000	53.51	-20.49	74.00	61.96	29.09	1.98	39.52	Peak	---	---
2	2688.000	50.85	-3.15	54.00	59.30	29.09	1.98	39.52	Average	---	---
3	4928.000	45.33	-28.67	74.00	49.80	33.21	2.47	40.15	Peak	---	---
4	7152.000	46.70	-27.30	74.00	47.87	35.51	2.82	39.50	Peak	---	---

Note:

Emission level (dBuV/m) = 20 log Emission level (uV/m)

Corrected Reading: Probe Factor + Cable Loss + Read Level - Preamp Factor = Level



- Modulation Type: 11g BPSK
- Temperature: 23°C
- Relative Humidity: 51%
- Duty Cycle of the Equipment During the Test: 100.00%
- Test Engineer: Ted Chiu

(A) Polarization: Horizontal

	Freq	Level	Over Limit	Limit Line	Read Level	Probe Factor	Cable Loss	Preamp Factor	Remark	Ant Pos	Table Pos
	MHz	dBuV/m	dB	dBuV/m	dBuV	dB	dB	dB		cm	deg
1	2688.000	48.64	-25.36	74.00	57.09	29.09	1.98	39.52	Peak	---	---
2	6436.000	46.51	-27.49	74.00	49.12	34.27	2.84	39.72	Peak	---	---
3	7192.000	47.64	-26.36	74.00	48.85	35.67	2.61	39.49	Peak	---	---

(B) Polarization: Vertical

	Freq	Level	Over Limit	Limit Line	Read Level	Probe Factor	Cable Loss	Preamp Factor	Remark	Ant Pos	Table Pos
	MHz	dBuV/m	dB	dBuV/m	dBuV	dB	dB	dB		cm	deg
1	2688.000	54.06	-19.94	74.00	62.51	29.09	1.98	39.52	Peak	---	---
2	2688.000	52.90	-1.10	54.00	61.35	29.09	1.98	39.52	Average	---	---
3	4924.000	47.53	-26.47	74.00	52.00	33.21	2.47	40.15	Peak	---	---
4	7252.000	47.34	-26.66	74.00	48.15	35.82	2.84	39.47	Peak	---	---

Note:

Emission level (dBuV/m) = 20 log Emission level (uV/m)

Corrected Reading: Probe Factor + Cable Loss + Read Level - Preamp Factor = Level



5.6.8. Test Results for CH 06 / 2437 MHz (for emission above 1GHz)

- Test Mode: Turbo Mode
- Modulation Type: OFDM BPSK
- Temperature: 23°C
- Relative Humidity: 51%
- Duty Cycle of the Equipment During the Test: 100.00%
- Test Engineer: Ted Chiu

(A) Polarization: Horizontal

	Freq	Level	Over Limit	Limit Line	Read Level	Probe Factor	Cable Loss	Preamp Factor	Remark	Ant Pos	Table Pos
	MHz	dBuV/m	dB	dBuV/m	dBuV	dB	dB	dB		cm	deg
1	2688.000	49.17	-24.83	74.00	57.62	29.09	1.98	39.52	Peak	---	---
2	4604.000	42.79	-31.21	74.00	47.98	32.59	2.35	40.13	Peak	---	---
3	7268.000	47.97	-26.03	74.00	48.49	35.88	3.07	39.47	Peak	---	---

(B) Polarization: Vertical

	Freq	Level	Over Limit	Limit Line	Read Level	Probe Factor	Cable Loss	Preamp Factor	Remark	Ant Pos	Table Pos
	MHz	dBuV/m	dB	dBuV/m	dBuV	dB	dB	dB		cm	deg
1	2688.000	53.27	-20.73	74.00	61.72	29.09	1.98	39.52	Peak	---	---
2	2688.000	51.63	-2.37	54.00	60.08	29.09	1.98	39.52	Average	---	---
3	4868.000	44.63	-29.37	74.00	49.17	33.05	2.55	40.14	Peak	---	---
4	7196.000	47.83	-26.17	74.00	49.04	35.67	2.61	39.49	Peak	---	---

Note:

Emission level (dBuV/m) = 20 log Emission level (uV/m)

Corrected Reading: Probe Factor + Cable Loss + Read Level - Preamp Factor = Level

5.6.9. Photographs of Radiated Emission Test Configuration

FRONT VIEW

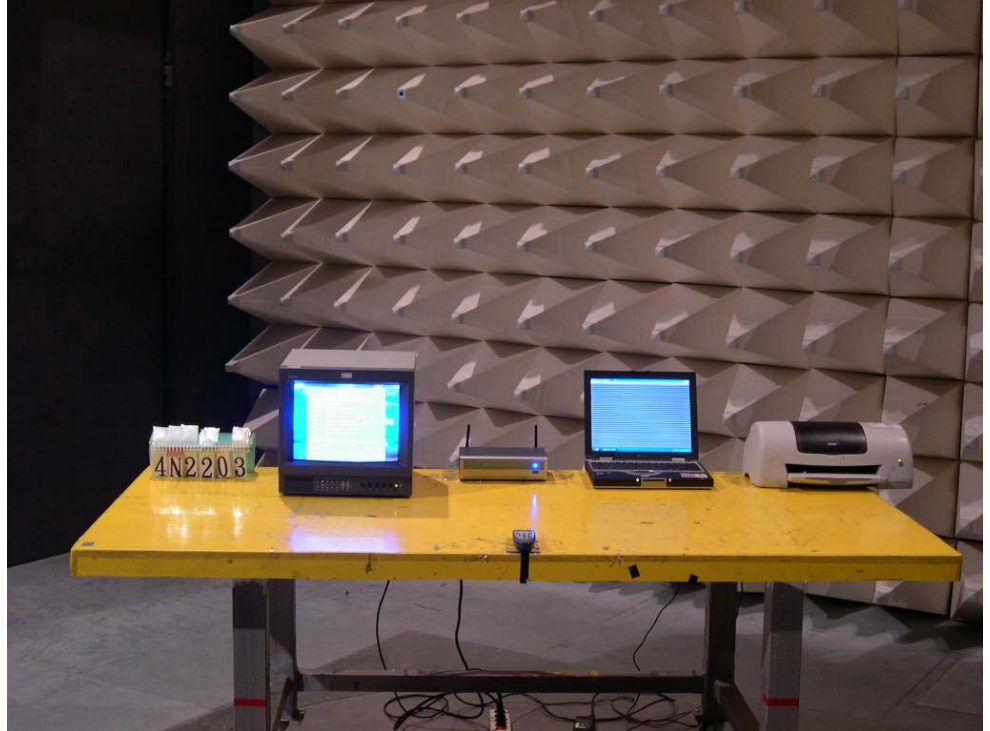

REAR VIEW

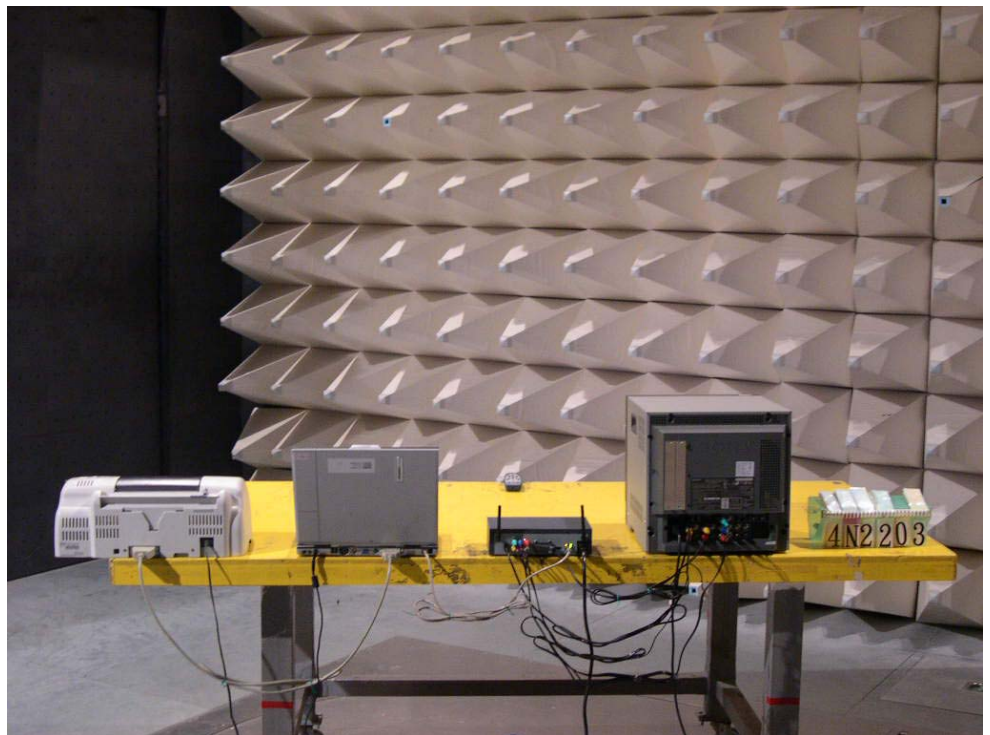



5.7. Antenna Requirements

5.7.1. Standard Applicable

47 CFR Part15 Section 15.203:

An intentional radiator shall be designed to ensure that no antenna other than that furnished by the responsible party shall be used with the device.

47 CFR Part15 Section 15.247 (b):

If transmitting antennas of directional gain greater than 6 dBi are used, the peak output power from the intentional radiator shall be reduced by the amount in dB that the directional gain of the antenna exceeds 6 dBi.

If the intentional radiator is used exclusively for fixed, point-to-point operations may employ transmitting antennas with directional gain greater than 6 dBi provided the maximum peak output power of the intentional radiator is reduced by 1 dB for every 3 dB that the directional gain of the antenna exceeds 6 dBi.

5.7.2. Antenna Connected Construction

There is no antenna connector for monopole antenna.



5.8. RF Exposure

5.8.1. Limit For Maximum Permissible Exposure (MPE)

This product can be classified as mobile device, so the 20cm separation distance warning is required. In this section, the power density at 20cm location is calculated to examine if it is lower than the limit.

(A) Limits for Occupational / Controlled Exposure

Frequency Range (MHz)	Electric Field Strength (E) (V/m)	Magnetic Field Strength (H) (A/m)	Power Density (S) (mW/ cm ²)	Averaging Time E ² , H ² or S (minutes)
0.3-3.0	614	1.63	(100)*	6
3.0-30	1842 / f	4.89 / f	(900 / f)*	6
30-300	61.4	0.163	1.0	6
300-1500			F/300	6
1500-100,000			5	6

(B) Limits for General Population / Uncontrolled Exposure

Frequency Range (MHz)	Electric Field Strength (E) (V/m)	Magnetic Field Strength (H) (A/m)	Power Density (S) (mW/cm ²)	Averaging Time E ² , H ² or S (minutes)
0.3-1.34	614	1.63	(100)*	30
1.34-30	824/f	2.19/f	(180/f)*	30
30-300	27.5	0.073	0.2	30
300-1500			F/1500	30
1500-100,000			1.0	30

F = frequency in MHz

*Plane-wave equivalent power density

5.8.2. MPE Calculation Method

$$E \text{ (V/m)} = \frac{\sqrt{30 \times P \times G}}{d} \qquad \text{Power Density: } Pd \text{ (mW/cm}^2\text{)} = \frac{E^2}{377}$$

E = Electric field (V/m)

P = Peak RF output power (mW)

G = EUT Antenna numeric gain (numeric)

d = Separation distance between radiator and human body (m)

The formula can be changed to

$$Pd = \frac{30 \times P \times G}{377 \times d^2}$$

From the peak EUT RF output power, the minimum mobile separation distance, d=20cm, as well as the gain



of the used antenna, the RF power density can be obtained.

5.8.3. Calculated Result and Limit

- Modulation Type: CCK
- Temperature: 23°C
- Relative Humidity: 51%
- Duty Cycle of the Equipment During the Test: 100.00%
- Test Engineer: Ted Chiu

Channel No.	Antenna Gain (dBi)	Antenna Gain (numeric)	Peak Output Power (dBm)	Peak Output Power (mW)	Power Density (S) (mW/cm ²)	Limit of Power Density (S) (mW/cm ²)
01	2.00	1.58	16.40	43.65	0.0137	1
06	2.00	1.58	16.70	46.77	0.0147	1
11	2.00	1.58	16.60	45.71	0.0144	1

- Modulation Type: BPSK
- Temperature: 23°C
- Relative Humidity: 51%
- Duty Cycle of the Equipment During the Test: 100.00%
- Test Engineer: Ted Chiu

Channel No.	Antenna Gain (dBi)	Antenna Gain (numeric)	Peak Output Power (dBm)	Peak Output Power (mW)	Power Density (S) (mW/cm ²)	Limit of Power Density (S) (mW/cm ²)
01	2.00	1.58	17.10	51.29	0.0161	1
06	2.00	1.58	17.20	52.48	0.0165	1
11	2.00	1.58	17.10	51.29	0.0161	1

- Test Mode: Turbo Mode
- Modulation Type: BPSK
- Temperature: 23°C
- Relative Humidity: 51%
- Duty Cycle of the Equipment During the Test: 100.00%
- Test Engineer: Ted Chiu

Channel No.	Antenna Gain (dBi)	Antenna Gain (numeric)	Peak Output Power (dBm)	Peak Output Power (mW)	Power Density (S) (mW/cm ²)	Limit of Power Density (S) (mW/cm ²)
01	2.00	1.58	16.40	43.65	0.0137	1



6. List of Measuring Equipments Used

Items	Instrument	Manufacturer	Model No.	Serial No.	Characteristics	Calibration Date	Remark
1	EMC Receiver	R&S	ESCS 30	100174	9 KHz – 2.75 GHz	Feb. 16, 2004	Conduction (CO04-HY)
2	LISN	MessTec	NNB-2/16Z	2001/004	9 KHz – 30 MHz	Jun. 09, 2004	Conduction (CO04-HY)
3	LISN (Support Unit)	MessTec	NNB-2/16Z	99041	9 KHz – 30 MHz	Apr. 27, 2004	Conduction (CO04-HY)
4	EMI Filter	LINDGREN	LRE-2030	2651	< 450 Hz	N/A	Conduction (CO04-HY)
5	RF Cable-CON	UTIFLEX	3102-26886-4	CB044	9KHz~30MHz	Apr. 21, 2004	Conduction (CO04-HY)
6	3m Semi Anechoic Chamber	SIDT FRANKONIA	SAC-3M	03CH03-HY	30MHz~1GHz 3m	Jun. 21, 2004	Radiation (03CH03-HY)
7	Spectrum analyzer	R&S	FSP40	100004	9KHZ~40GHz	Aug. 31, 2004	Radiation (03CH03-HY)
8	Amplifier	HP	8447D	2944A09072	100KHz – 1.3GHz	Nov. 04, 2004	Radiation (03CH03-HY)
9	Biconical Antenna	SCHWARZBECK	VHBB 9124	301	30MHz –200MHz	Jul. 28, 2004	Radiation (03CH03-HY)
10	Log Antenna	SCHWARZBECK	VUSLP 9111	221	200MHz -1GHz	Jul. 28, 2004	Radiation (03CH03-HY)
11	RF Cable-R03m	Jye Bao	RG142	CB021	30MHz~1GHz	Dec. 02, 2004	Radiation (03CH03-HY)
12	Amplifier	MITEQ	AFS44	849984	100MHz~26.5GHz	Mar. 26, 2004	Radiation (03CH03-HY)
13	Horn Antenna	EMCO	3115	6741	1GHz – 18GHz	Apr. 07, 2004	Radiation (03CH03-HY)
14	Turn Table	HD	DS 420	420/650/00	0 ~ 360 degree	N/A	Radiation (03CH03-HY)
15	Antenna Mast	HD	MA 240	240/560/00	1 m - 4 m	N/A	Radiation (03CH03-HY)
16	Horn Antenna	Schwarzbeck	BBHA9170	154	18GHz~40GHz	Jun. 09, 2004	Radiation (03CH03-HY)
17	RF Cable-HIGH	Jye Bao	RG142	CB030-HIGH	1GHz~29.5GHz	Dec. 04, 2004	Radiation (03CH03-HY)

※ Calibration Interval of instruments listed above is one year.



Items	Instrument	Manufacturer	Model No.	Serial No.	Characteristics	Calibration Date	Remark
18	Spectrum analyzer	R&S	FSP7	838858/014	9KHZ~7GHZ	Sep. 02, 2004	Conducted (TH01-HY)
19	Power meter	R&S	NRVS	100444	DC~40GHz	Jun. 15, 2004	Conducted (TH01-HY)
20	Power sensor	R&S	NRV-Z55	100049	DC~40GHz	Jun. 15, 2004	Conducted (TH01-HY)
21	Power Sensor	R&S	NRV-Z32	100057	30MHz-6GHz	Jun. 15, 2004	Conducted (TH01-HY)
22	AC power source	HPC	HPA-500W	HPA-9100024	AC 0~300V	Jun. 16, 2004	Conducted (TH01-HY)
23	AC power source	G.W.	GPC-6030D	C671845	DC 1V~60V	Nov. 05, 2004	Conducted (TH01-HY)
24	Temp. and Humidity Chamber	KSON	THS-C3L	612	N/A	Sep. 30	Conducted (TH01-HY)
25	RF CABLE-1m	Jye Bao	RG142	CB034-1m	20MHz~7GHz	Jan. 01, 2004	Conducted (TH01-HY)
26	RF CABLE-2m	Jye Bao	RG142	CB035-2m	20MHz~1GHz	Jan. 01, 2004	Conducted (TH01-HY)

※ Calibration Interval of instruments listed above is one year.