



# A Test Lab Techno Corp.

Changan Lab : No. 140 -1, Changan Street, Bade City, Taoyuan County, Taiwan R.O.C.

Tel : 886-3-271-0188 / Fax : 886-3-271-0190



## SAR EVALUATION REPORT

Test Report No.	: 1412FS14
Applicant	: Netgear Inc.
Product Type	: Mobile Hot Spot
Trade Name	: Netgear
Model Number	: AC779S-200
Date of Received	: Nov. 19, 2014
Test Period	: Nov. 26, 2014 ~ Jan. 16, 2015
Date of Issued	: Jan. 19, 2015
Test Environment	: Ambient Temperature : $22 \pm 2$ ° C Relative Humidity : 40 - 70 %
Standard	: KDB 865664 D01 SAR Measurement 100 MHz to 6 GHz v01r03 KDB 865664 D02 RF Exposure Reporting v01r01 ANSI/IEEE C95.1-1999 IEEE Std. 1528-2013 IEEE Std. 1528a-2005 KDB 447498 D01 KDB 248227 D01 KDB 941225 D01 / D05 / D06 47 CFR Part §2.1093;
Test Lab Location	: Chang-an Lab



1. The test operations have to be performed with cautious behavior, the test results are as attached.
2. The test results are under chamber environment of A Test Lab Techno Corp. A Test Lab Techno Corp. does not assume responsibility for any conclusions and generalizations drawn from the test results with regard to other specimens or samples.
3. The measurement report has to be written approval of A Test Lab Techno Corp. It may only be reproduced or published in full. This report shall not be reproduced except in full, without the written approval of A Test Lab Techno Corp. The test results in the report only apply to the tested sample.

Approved By : Bill Hu  
(Bill Hu)

Tested By : Sky Chou  
(Sky Chou)



# Contents

1. Summary of Maximum Reported SAR Value .....	4
2. Description of Equipment under Test (EUT) .....	5
3. Introduction.....	6
3.1 SAR Definition .....	6
4. SAR Measurement Setup .....	7
4.1 DASY E-Field Probe System.....	8
4.2 Data Acquisition Electronic (DAE) System.....	11
4.3 Robot.....	11
4.4 Measurement Server.....	11
4.5 Device Holder.....	12
4.6 Phantom - SAM v4.0 .....	12
4.7 Oval Flat Phantom - ELI 4.0.....	13
4.8 Data Storage and Evaluation.....	13
5. Tissue Simulating Liquids.....	16
5.1 Ingredients.....	17
5.2 Recipes.....	17
5.3 Liquid Depth .....	18
6. SAR Testing with RF Transmitters .....	19
6.1 SAR Testing with WCDMA Transmitters .....	19
6.2 SAR Testing with HSDPA Transmitters .....	19
6.3 SAR Testing with LTE-FDD Transmitters .....	22
6.4 LTE Frequency range and channel bandwidth.....	22
6.5 Power reduction .....	24
6.6 SAR Testing with 802.11 Transmitters.....	25
6.7 General Device Setup .....	25
6.8 Conducted Power.....	27
6.9 Antenna location.....	48
6.10 Stand-alone SAR Evaluate.....	50
6.11 Simultaneous Transmitting Evaluate.....	52
6.12 SAR test reduction according to KDB .....	55
7. System Verification and Validation .....	56
7.1 Symmetric Dipoles for System Verification .....	56
7.2 Liquid Parameters .....	57
7.3 Verification Summary .....	59
7.4 Validation Summary .....	60
8. Test Equipment List.....	61
9. Measurement Uncertainty .....	62



10. Measurement Procedure.....	64
10.1 Spatial Peak SAR Evaluation .....	64
10.2 Area & Zoom Scan Procedures .....	65
10.3 Volume Scan Procedures.....	65
10.4 SAR Averaged Methods .....	65
10.5 Power Drift Monitoring.....	65
11. SAR Test Results Summary .....	66
11.1 Head Measurement SAR .....	66
11.2 Body Measurement SAR.....	66
11.3 Hot-spot mode Measurement SAR .....	66
11.4 Extremity Measurement SAR.....	71
11.5 SAR Measurement Variability.....	71
11.6 Std. C95.1-1999 RF Exposure Limit.....	72
12. Conclusion.....	73
13. References .....	73
14. SAR Measurement Guidance .....	74
Appendix A - System Performance Check.....	75
Appendix B - SAR Measurement Data .....	84
Appendix C - Calibration.....	183



**1. Summary of Maximum Reported SAR Value**

Band	Max. Reported Body SAR1g (W/Kg)
WCDMA Band II	1.189
WCDMA Band V	0.780
LTE Band 2 (QPSK)	1.422
LTE Band 4 (QPSK)	1.442
LTE Band 5 (QPSK)	0.726
LTE Band 17 (QPSK)	1.148
2.4 G WLAN	0.048
Simultaneous Transmission	1.490

Note: The SAR limit (Head & Body: SAR1g 1.6 W/kg) for general population / uncontrolled exposure is specified in ANSI/IEEE C95.1-1991.



## 2. Description of Equipment under Test (EUT)

Applicant	Netgear Inc.		
Applicant Address	350 East Plumeria Drive, San Jose, CA 95134		
Manufacture	Netgear Inc.		
Manufacture Address	Suite 168 – 10760 Shellbridge Way, Richmond, BC Canada V6X 3H1		
Product Type	Mobile Hot Spot		
Trade Name	Netgear		
Model Number	AC779S-200		
IMEI No.	014260000002034		
Hardware Version	REV.2		
Software Version	FXC9X15B_45.00.03.01_MFG		
FCC ID	PY3AC779S		
RF Function	WCDMA(RMC 12.2K) / HSDPA / HSUPA Band II WCDMA(RMC 12.2K) / HSDPA / HSUPA Band V LTE Band 2 / Band 4 / Band 5 / Band 17 IEEE 802.11b / 802.11g / 802.11n (2.4GHz) 20MHz IEEE 802.11n (2.4GHz) 40MHz		
Tx Frequency	Band	Operate Frequency (MHz)	
	WCDMA(RMC 12.2K) / HSDPA / HSUPA Band II	1852.4 - 1907.6	
	WCDMA (RMC 12.2K) / HSDPA / HSUPA Band V	826.4 - 846.6	
	LTE Band 2 (BW 1.4, 3, 5, 10, 15, 20 MHz)	1850.7 – 1909.3	
	LTE Band 4 (BW 1.4, 3, 5, 10, 15, 20 MHz)	1710.7 - 1754.3	
	LTE Band 5 (BW 1.4, 3, 5, 10 MHz)	824.7 – 848.3	
	LTE Band 17 (BW 5, 10 MHz)	706.5 – 713.5	
	IEEE 802.11b / 802.11g / 802.11n (2.4GHz) 20MHz	2412 - 2462	
	IEEE 802.11n (2.4GHz) 40MHz	2422 - 2452	
RF Conducted Power (Avg.)	Band	Power	
		W	dBm
	WCDMA(RMC 12.2K) / HSDPA / HSUPA Band II	0.190	22.79
	WCDMA (RMC 12.2K) / HSDPA / HSUPA Band V	0.212	23.26
	LTE Band 2	0.191	22.80
	LTE Band 4	0.173	22.37
	LTE Band 5	0.214	23.30
	LTE Band 17	0.247	23.93
	IEEE 802.11b	0.010	9.85
	IEEE 802.11g	0.009	9.70
	IEEE 802.11n (2.4GHz) 20MHz	0.010	9.93
IEEE 802.11n (2.4GHz) 40MHz	0.009	9.38	
Antenna Type	FPC Antenna		
Device Category	Portable Device		
RF Exposure Environment	General Population / Uncontrolled		
Application Type	Certification		

This wireless portable device has been shown to be capable of compliance for localized specific absorption rate (SAR) for uncontrolled environment / general population exposure limits specified in Standard C95.1-1999 and had been tested in accordance with the measurement procedures specified in IEEE Std. 1528-2013 and IEEE Std. 1528a-2005.

### 3. Introduction

The A Test Lab Techno Corp. has performed measurements of the maximum potential exposure to the user of **Netgear Inc. Trade Name : Netgear Model(s) : AC779S-200**. The test procedures, as described in American National Standards, Institute C95.1-1999 [ 1 ] were employed and they specify the maximum exposure limit of 1.6mW/g as averaged over any 1 gram of tissue for portable devices being used within 20cm between user and EUT in the uncontrolled environment. A description of the product and operating configuration, detailed summary of the test results, methodology and procedures used in the equipment used are included within this test report.

#### 3.1 SAR Definition

Specific Absorption Rate (SAR) is defined as the time derivative (rate) of the incremental energy (dw) absorbed by (dissipated in) an incremental mass (dm) contained in a volume element (dv) of a given density ( $\rho$ ). It is also defined as the rate of RF energy absorption per unit mass at a point in an absorbing body (see Figure 2).

$$\text{SAR} = \frac{d}{dt} \left( \frac{dw}{dm} \right) = \frac{d}{dt} \left( \frac{dw}{\rho dv} \right)$$

Figure 2. SAR Mathematical Equation

SAR is expressed in units of Watts per kilogram (W/kg)

$$\text{SAR} = \frac{\sigma E^2}{\rho}$$

Where :

- $\sigma$  = conductivity of the tissue (S/m)
- $\rho$  = mass density of the tissue (kg/m<sup>3</sup>)
- $E$  = RMS electric field strength (V/m)

\* Note :

The primary factors that control rate of energy absorption were found to be the wavelength of the incident field in relations to the dimensions and geometry of the irradiated organism, the orientation of the organism in relation to the polarity of field vectors, the presence of reflecting surfaces, and whether conductive contact is made by the organism with a ground plane [ 2 ]

## 4. SAR Measurement Setup

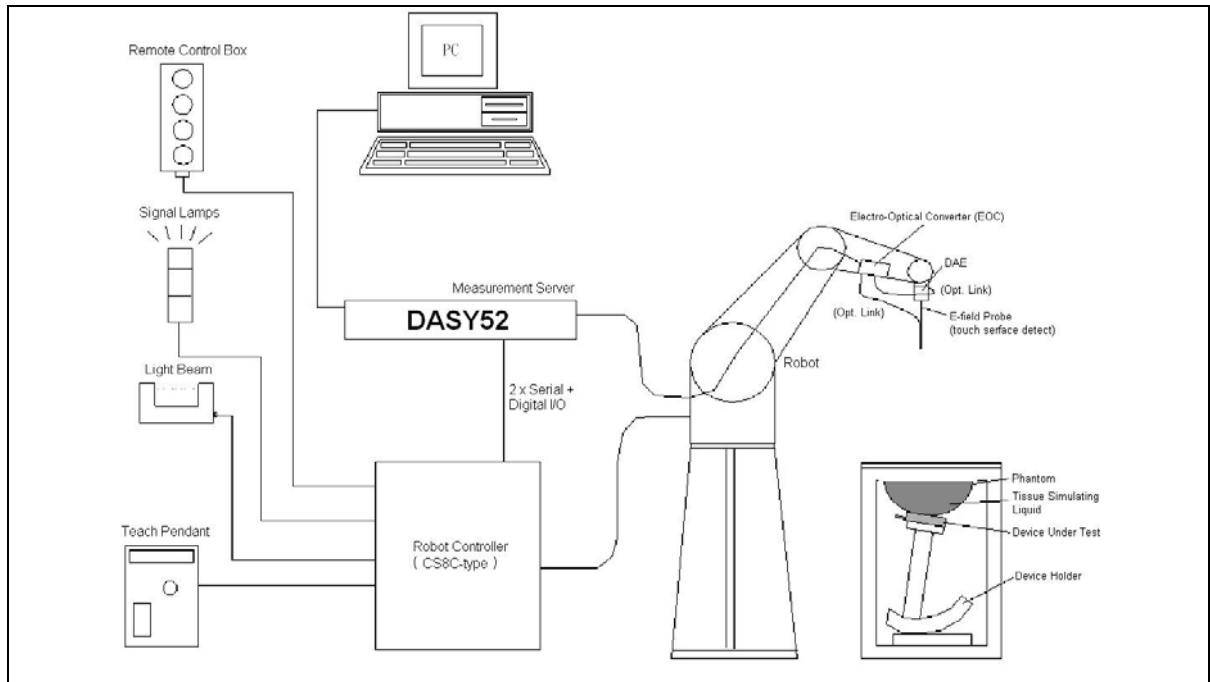

The DASY52 system for performing compliance tests consists of the following items:

1. A standard high precision 6-axis robot (Stäubli TX family) with controller, teach pendant and software. An arm extension for accommodating the data acquisition electronics (DAE).
2. A dosimetric probe, i.e., an isotropic E-field probe optimized and calibrated for usage in tissue simulating liquid. The probe is equipped with an optical surface detector system.
3. A data acquisition electronics (DAE) which performs the signal amplification, signal multiplexing, AD-conversion, offset measurements, mechanical surface detection, collision detection, etc. The unit is battery powered with standard or rechargeable batteries. The signal is optically transmitted to the EOC.
4. The function of the measurement server is to perform the time critical tasks such as signal filtering, control of the robot operation and fast movement interrupts.
5. A probe alignment unit which improves the (absolute) accuracy of the probe positioning.
6. A computer operating Windows 2000 or Windows XP.
7. DASY52 software.
8. Remote controls with teach pendant and additional circuitry for robot safety such as warning lamps, etc.
9. The SAM twin phantom enabling testing left-hand and right-hand usage.
10. The device holder for handheld mobile phones.
11. Tissue simulating liquid mixed according to the given recipes.
12. Validation dipole kits allowing validating the proper functioning of the system.



## 4.1 DASYS E-Field Probe System

The SAR measurements were conducted with the dosimetric probe (manufactured by SPEAG), designed in the classical triangular configuration [ 3 ] and optimized for dosimetric evaluation. The probe is constructed using the thick film technique; with printed resistive lines on ceramic substrates. The probe is equipped with an optical multi-fiber line ending at the front of the probe tip. It is connected to the EOC box on the robot arm and provides an automatic detection of the phantom surface. Half of the fibers are connected to a pulsed infrared transmitter, the other half to a synchronized receiver. As the probe approaches the surface, the reflection from the surface produces a coupling from the transmitting to the receiving fibers. This reflection increases first during the approach, reaches maximum and then decreases. If the probe is flatly touching the surface, the coupling is zero. The distance of the coupling maximum to the surface is independent of the surface reflectivity and largely independent of the surface to probe angle. The DASYS software reads the reflection during a software approach and looks for the maximum using a 2nd order fitting. The approach is stopped when reaching the maximum.



#### 4.1.1 E-Field Probe Specification

Construction	Symmetrical design with triangular core Built-in optical fiber for surface detection System Built-in shielding against static charges PEEK enclosure material (resistant to organic solvents, e.q., glycol)
Calibration	In air from 10 MHz to 6 GHz In brain and muscle simulating tissue at frequencies of 750MHz, 835MHz, 1750MHz, 1900MHz and 2450MHz (accuracy $\pm 8\%$ ) Calibration for other liquids and frequencies upon request
Frequency	$\pm 0.2$ dB (30 MHz to 6 GHz)
Directivity	$\pm 0.3$ dB in brain tissue (rotation around probe axis) $\pm 0.5$ dB in brain tissue (rotation normal probe axis) Dynamic Range 10 $\mu$ W/g to > 100mW/g; Linearity: $\pm 0.2$ dB
Dimensions	Overall length: 337mm Tip length: 9mm Body diameter: 10mm Tip diameter: 2.5mm Distance from probe tip to dipole centers: 1.0mm
Application	General dosimetry up to 6GHz Compliance tests of mobile phones Fast automatic scanning in arbitrary phantoms



Figure 3. E-field Probe



Figure 4. Probe setup on robot



#### 4.1.2 E-Field Probe Calibration process

##### Dosimetric Assessment Procedure

Each E-Probe/Probe Amplifier combination has unique calibration parameters. A TEM cell calibration procedure is conducted to determine the proper amplifier settings to enter in the probe parameters. The amplifier settings are determined for a given frequency by subjecting the probe to a known E-field density (1 mW/cm<sup>2</sup>) using an RF Signal generator, TEM cell, and RF Power Meter.

##### Free Space Assessment

The free space E-field from amplified probe outputs is determined in a test chamber. This calibration can be performed in a TEM cell if the frequency is below 1 GHz and in a waveguide or other methodologies above 1 GHz for free space. For the free space calibration, the probe is placed in the volumetric center of the cavity and at the proper orientation with the field. The probe is rotated 360 degrees until the three channels show the maximum reading. The power density readings equates to 1 mW/cm<sup>2</sup>.

##### Temperature Assessment

E-field temperature correlation calibration is performed in a flat phantom filled with the appropriate simulated head tissue. The E-field in the medium correlates with the temperature rise in the dielectric medium. For temperature correlation calibration a RF transparent thermistor-based temperature probe is used in conjunction with the E-field probe.

$$\text{SAR} = C \frac{\Delta T}{\Delta t}$$

Where :

$\Delta t$  = Exposure time (30 seconds),

C = Heat capacity of tissue (head or body),

$\Delta T$  = Temperature increase due to RF exposure.

$$\text{Or } \text{SAR} = \frac{|E|^2 \sigma}{\rho}$$

Where :

$\sigma$  = Simulated tissue conductivity,

$\rho$  = Tissue density (kg/m<sup>3</sup>).



## 4.2 Data Acquisition Electronic (DAE) System

### Cell Controller

Processor : Intel Core(TM)2 CPU  
Clock Speed : @ 1.86GHz  
Operating System : Windows XP Professional

### Data Converter

Features : Signal Amplifier, multiplexer, A/D converter, and control logic  
Software : DASY52 v52.8 (7) & SEMCAD X Version 14.6.10 (7164)  
Connecting Lines : Optical downlink for data and status info  
Optical uplink for commands and clock

## 4.3 Robot

Positioner : Stäubli Unimation Corp. Robot Model: TX90XL  
Repeatability :  $\pm 0.02$  mm  
No. of Axis : 6

## 4.4 Measurement Server

Processor : PC/104 with a 400MHz intel ULV Celeron  
I/O-board : Link to DAE4 (or DAE3)  
16-bit A/D converter for surface detection system  
Digital I/O interface  
Serial link to robot  
Direct emergency stop output for robot

#### 4.5 Device Holder

The DASY device holder is constructed of low-loss POM material having the following dielectric parameters: relative permittivity  $\epsilon=3$  and loss tangent  $\delta=0.02$ . The amount of dielectric material has been reduced in the closest vicinity of the device, since measurements have suggested that the influence of the clamp on the test results could thus be lowered.

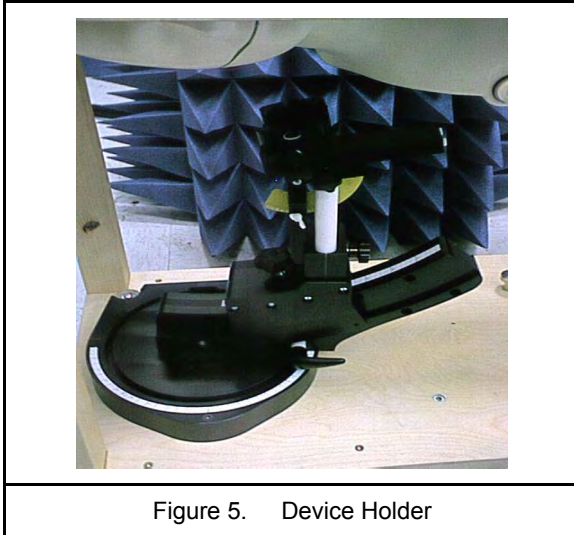

#### 4.6 Phantom - SAM v4.0

The shell corresponds to the specifications of the Specific Anthropomorphic Mannequin (SAM) phantom defined in IEEE 1528 and IEC 62209. It enables the dosimetric evaluation of left and right hand phone usage as well as body mounted usage at the flat phantom region. A cover prevents evaporation of the liquid. Reference markings on the phantom allow the complete setup of all predefined phantom positions and measurement grids by manually teaching three points with the robot.

Shell Thickness	2 ±0.2 mm
Filling Volume	Approx. 25 liters
Dimensions	1000x500 mm (LxW)
Table 1. Specification of SAM v4.0	



Figure 6. SAM Twin Phantom

## 4.7 Oval Flat Phantom - ELI 4.0

The shell corresponds to the specifications of the Specific Anthropomorphic Mannequin (Oval Flat) phantom defined in IEEE 1528-2013, IEEE Std. 1528a-2005, CENELEC 50361 and IEC 62209. It enables the dosimetric evaluation of wireless portable device usage as well as body mounted usage at the flat phantom region. A cover prevents evaporation of the liquid. Reference markings on the phantom allow the complete setup of all predefined phantom positions and measurement grids by manually teaching three points with the robot.

Shell Thickness	2 ±0.2 mm
Filling Volume	Approx. 30 liters
Dimensions	190×600×400 mm (H×L×W)
Table 2. Specification of ELI 4.0	

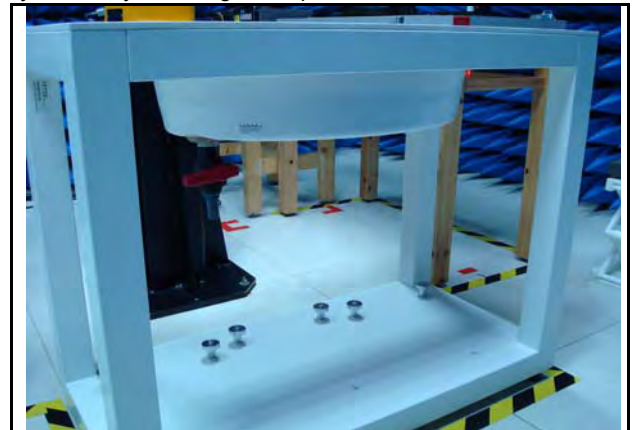

Figure 7. Oval Flat Phantom

## 4.8 Data Storage and Evaluation

### 4.8.1 Data Storage

The DASY software stores the assessed data from the data acquisition electronics as raw data (in microvolt readings from the probe sensors), together with all the necessary software parameters for the data evaluation (probe calibration data, liquid parameters and device frequency and modulation data) in measurement files with the extension DA4 or DA5. The post processing software evaluates the desired unit and format for output each time the data is visualized or exported. This allows verification of the complete software setup even after the measurement and allows correction of erroneous parameter settings. For example, if a measurement has been performed with an incorrect crest factor parameter in the device setup, the parameter can be corrected afterwards and the data can be reevaluated.



#### 4.8.2 Data Evaluation

The DASY post processing software (SEMCAD) automatically executes the following procedures to calculate the field units from the microvolt readings at the probe connector. The parameters used in the evaluation are stored in the configuration modules of the software :

- Probe parameters : - Sensitivity  $Norm_i, ai0, ai1, ai2$   
- Conversion factor  $ConvFi$   
- Diode compression point  $dcp_i$
- Device parameters : - Frequency  $f$   
- Crest factor  $cf$
- Media parameters : - Conductivity  $\sigma$   
- Density  $\rho$

These parameters must be set correctly in the software. They can be found in the component documents or they can be imported into the software from the configuration files issued for the DASY components. In the direct measuring mode of the multimeter option, the parameters of the actual system setup are used. In the scan visualization and export modes, the parameters stored in the corresponding document files are used.

The first step of the evaluation is a linearization of the filtered input signal to account for the compression characteristics of the detector diode. The compensation depends on the input signal, the diode type and the DC-transmission factor from the diode to the evaluation electronics. If the exciting field is pulsed, the crest factor of the signal must be known to correctly compensate for peak power. The formula for each channel can be given as :

$$V_i = U_i + U_i^2 \cdot \frac{cf}{dcp_i}$$

- With  $V_i$  = compensated signal of channel i (i = x, y, z)  
 $U_i$  = input signal of channel i (i = x, y, z)  
 $cf$  = crest factor of exciting field (DASY parameter)  
 $dcp_i$  = diode compression point (DASY parameter)

From the compensated input signals the primary field data for each channel can be evaluated :

E-field probes : 
$$E_i = \sqrt{\frac{V_i}{Norm_i \cdot ConvF}}$$



$$H_i = \sqrt{V_i} \cdot \frac{a_{i0} + a_{i1}f + a_{i2}f^2}{f}$$

H-field probes :

- with  $V_i$  = compensated signal of channel i (i = x, y, z)  
 $Norm_i$  = sensor sensitivity of channel i (i = x, y, z)  
 $\mu V/(V/m)^2$  for E-field Probes  
 $ConvF$  = sensitivity enhancement in solution  
 $a_{ij}$  = sensor sensitivity factors for H-field probes  
 $f$  = carrier frequency [GHz]  
 $E_i$  = electric field strength of channel i in V/m  
 $H_i$  = magnetic field strength of channel i in A/m

The RSS value of the field components gives the total field strength (Hermitian magnitude) :

$$E_{tot} = \sqrt{E_x^2 + E_y^2 + E_z^2}$$

The primary field data are used to calculate the derived field units.

$$SAR = E_{tot}^2 \cdot \frac{\sigma}{\rho \cdot 1000}$$

- with  $SAR$  = local specific absorption rate in mW/g  
 $E_{tot}$  = total field strength in V/m  
 $\sigma$  = conductivity in [mho/m] or [Siemens/m]  
 $\rho$  = equivalent tissue density in g/cm<sup>3</sup>

\* Note : That the density is set to 1, to account for actual head tissue density rather than the density of the tissue simulating liquid.

The power flow density is calculated assuming the excitation field to be a free space field.

$$P_{pwe} = \frac{E_{tot}^2}{3770} \quad \text{or} \quad P_{pwe} = \frac{H_{tot}^2}{37.7}$$

- with  $P_{pwe}$  = equivalent power density of a plane wave in mW/cm<sup>2</sup>  
 $E_{tot}$  = total electric field strength in V/m  
 $H_{tot}$  = total magnetic field strength in A/m



## 5. Tissue Simulating Liquids

The mixture is calibrated to obtain proper dielectric constant (permittivity) and conductivity of the tissue.

The dielectric parameters of the liquids were verified prior to the SAR evaluation using an 85070C Dielectric Probe Kit and an E5071B Network Analyzer.

### IEEE SCC-34/SC-2 in 1528 recommended Tissue Dielectric Parameters

The head tissue dielectric parameters recommended by the IEEE SCC-34/SC-2 in 1528 have been incorporated in the following table. These head parameters are derived from planar layer models simulating the highest expected SAR for the dielectric properties and tissue thickness variations in human head. Other head and body tissue parameters that have not been specified in 1528 are derived from the tissue dielectric parameters computed from the 4-Cole-Cole equation and extrapolated according to the head parameter specified in 1528.

Target Frequency	Head		Body	
(MHz)	$\epsilon_r$	$\sigma$ (S/m)	$\epsilon_r$	$\sigma$ (S/m)
150	52.3	0.76	61.9	0.80
300	45.3	0.87	58.2	0.92
450	43.5	0.87	56.7	0.94
835	41.5	0.90	55.2	0.97
900	41.5	0.97	55.0	1.05
915	41.5	0.98	55.0	1.06
1450	40.5	1.20	54.0	1.30
1610	40.3	1.29	53.8	1.40
1800 - 2000	40.0	1.40	53.3	1.52
2450	39.2	1.80	52.7	1.95
3000	38.5	2.40	52.0	2.73
5800	35.3	5.27	48.2	6.00
( $\epsilon_r$ = relative permittivity, $\sigma$ = conductivity and $\rho = 1000$ kg/m <sup>3</sup> )				

Table 3. Tissue dielectric parameters for head and body phantoms





## 5.1 Ingredients

The following ingredients are used:

- Water: deionized water (pure H<sub>2</sub>O), resistivity ≥ 16 M Ω -as basis for the liquid
- Sugar: refined white sugar (typically 99.7 % sucrose, available as crystal sugar in food shops)  
-to reduce relative permittivity
- Salt: pure NaCl -to increase conductivity
- Cellulose: Hydroxyethyl-cellulose, medium viscosity (75-125 mPa.s, 2% in water, 20 °C), CAS # 54290 -to increase viscosity and to keep sugar in solution.
- Preservative: Preventol D-7 Bayer AG, D-51368 Leverkusen, CAS # 55965-84-9 -to prevent the spread of bacteria and molds
- DGBE: Diethylenglycol-monobutyl ether (DGBE), Fluka Chemie GmbH, CAS # 112-34-5 -to reduce relative permittivity

## 5.2 Recipes

The following tables give the recipes for tissue simulating liquids to be used in different frequency bands.

Note: The goal dielectric parameters (at 22 °C) must be achieved within a tolerance of ±5% for ε and ±5% for σ.

Ingredients (% by weight)	Frequency (MHz)											
	750		835		1750		1900		2450		2600	
Tissue Type	Head	Body	Head	Body	Head	Body	Head	Body	Head	Body	Head	Body
Water	39.28	51.30	41.45	52.40	54.50	40.20	54.90	40.40	62.70	73.20	60.30	71.40
Salt (NaCl)	1.47	1.42	1.45	1.50	0.17	0.49	0.18	0.50	0.50	0.10	0.60	0.20
Sugar	58.15	46.18	56.00	45.00	0.00	0.00	0.00	0.00	0.00	0.00	0.00	0.00
HEC	1.00	1.00	1.00	1.00	0.00	0.00	0.00	0.00	0.00	0.00	0.00	0.00
Bactericide	0.10	0.10	0.10	0.10	0.00	0.00	0.00	0.00	0.00	0.00	0.00	0.00
Triton X-100	0.00	0.00	0.00	0.00	0.00	0.00	0.00	0.00	0.00	0.00	0.00	0.00
DGBE	0.00	0.00	0.00	0.00	45.33	59.31	44.92	59.10	36.80	26.70	39.10	28.40
Dielectric Constant	41.88	54.60	42.54	56.10	40.10	53.60	39.90	54.00	39.80	52.50	39.80	52.50
Conductivity (S/m)	0.90	0.97	0.91	0.95	1.39	1.49	1.42	1.45	1.88	1.78	1.88	1.78

Salt: 99% Pure Sodium Chloride

Sugar: 98% Pure Sucrose

Water: De-ionized, 16 M Ω<sup>+</sup> resistivity

HEC: Hydroxyethyl Cellulose

DGBE: 99% Di(ethylene glycol) butyl ether, [2-(2-butoxyethoxy)ethanol]

Triton X-100 (ultra pure): Polyethylene glycol mono [4-(1,1, 3, 3-tetramethylbutyl)phenyl]ether

### 5.3 Liquid Depth

According to KDB865664 ,the depth of tissue-equivalent liquid in a phantom must be  $\geq 15.0$  cm with  $\leq \pm 0.5$  cm variation for SAR measurements  $\leq 3$  GHz and  $\geq 10.0$  cm with  $\leq \pm 0.5$  cm variation for measurements  $> 3$  GHz.

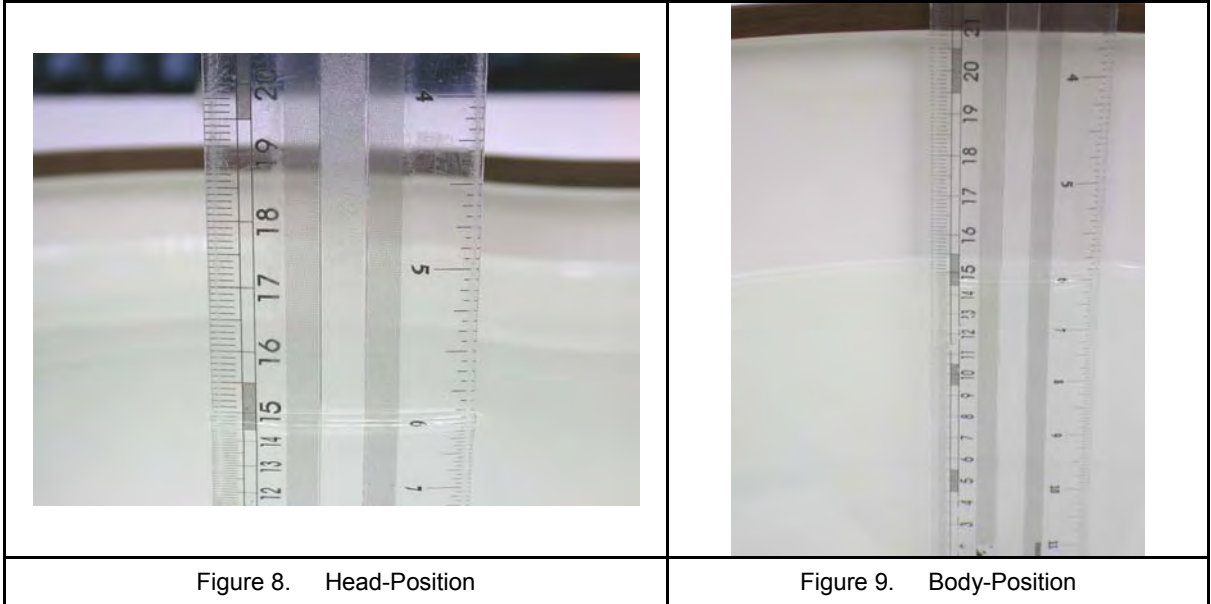



## 6. SAR Testing with RF Transmitters

### 6.1 SAR Testing with WCDMA Transmitters

Configure the basestation to support all WCDMA tests in respect to the 3GPP 34.121. Measure the power at Ch4132, 4183 and 4233 for US cell; Ch9262, 9400 and 9538 for US PCS Band.

- Step 1: set a Test Mode 1 loop back with a 12.2kbps Reference Measurement Channel (RMC).
- Step 2: set and send continuously up power control commands to the device.
- Step 3: measure the power at the device antenna connector using the power meter with average detector and test SAR

### 6.2 SAR Testing with HSDPA Transmitters

#### HSDPA Date Devices setup for SAR Measurement

HSDPA should be configured according to the UE category of a test device. The number of HS-DSCH/HS-PDSCHs, HARQ processes, minimum inter-TTI interval, transport block sizes and RV coding sequence are defined by the H-set. To maintain a consistent test configuration and stable transmission conditions, QPSK is used in the H-set for SAR testing. HS-DPCCH should be configured with a CQI feedback cycle of 4 ms with a CQI repetition factor of 2 to maintain a constant rate of active CQI slots. DPCCH and DPDCH gain factors ( $\beta_c$ ,  $\beta_d$ ), and HS-DPCCH power offset parameters ( $\Delta_{ACK}$ ,  $\Delta_{NACK}$ ,  $\Delta_{CQI}$ ) should be set according to values indicated in the Table below. The CQI value is determined by the UE category, transport block size, number of HS-PDSCHs and modulation used in the H-set.

Setup for Release 5 HSDPA							
Sub-test	$\beta_c$	$\beta_d$	$\beta_d$ (SF)	$\beta_c/\beta_d$	$\beta_{hs}^{(1,2)}$	CM <sup>(3)</sup> (dB)	MRP <sup>(3)</sup> (dB)
1	2/15	15/15	64	2/15	4/15	0.0	0.0
2	12/15(4)	15/15(4)	64	12/15(4)	24/15	1.0	0.0
3	15/15	8/15	64	15/8	30/15	1.5	0.5
4	15/15	4/15	64	15/4	30/15	1.5	0.5

Note

1.  $\Delta_{ACK}$ ,  $\Delta_{NACK}$  and  $\Delta_{CQI} = 8 \Leftrightarrow A_{hs} = \beta_{hs}/\beta_c = 30/15 \Leftrightarrow \beta_{hs} = 30/15 * \beta_c$
2. For the HS-DPCCH power mask requirement test in clause 5.2C, 5.7A, and the Error Vector Magnitude (EVM) with HS-DPCCH test in clause 5.13.1A and HSDPA EVM with phase discontinuity in clause 5.13.1AA,  $\Delta_{ACK}$  and  $\Delta_{NACK} = 30/15$  with  $\beta_{hs} = 30/15 * \beta_c$  and  $\Delta_{CQI} = 24/15$  with  $\beta_{hs} = 24/15 * \beta_c$
3. CM = 1 for  $\beta_c/\beta_d = 12/15$ ,  $\beta_{hs}/\beta_c = 24/15$ . For all other combinations of DPDCH, DPCCH and HS-DPCCH the MPR is based on the relative CM difference. This is applicable for only UEs that support HSDPA in release 6 and later releases.
4. For subtest 2 the  $\beta_c/\beta_d$  ratio of 12/15 for the TFC during the measurement period (TF1, TF0) is achieved by setting the signaled gain factors for the reference TFC (TF1, TF1) to  $\beta_c = 11/15$  and  $\beta_d = 15/15$ .



### **HSPA Data Devices setup for SAR Measurement.**

The following procedures are applicable to HSPA (HSUPA/HSDPA) data devices operating under 3GPP Release 6. Body exposure conditions generally apply to these devices, including handsets and data modems operating in various electronic devices. HSUPA operates in conjunction with WCDMA and HSDPA. SAR is initially measured in WCDMA test configurations without HSPA. The default test configuration is to establish a radio link between the DUT and a communication test set to configure a 12.2 kbps RMC (reference measurement channel) in Test Loop Mode 1. SAR for HSPA is selectively measured with HS-DPCCH, EDPCCH and E-DPDCH, all enabled, along with a 12.2 kbps RMC using the highest SAR configuration in WCDMA with 12.2 kbps RMC only. An FRC is configured according to HSDPCCH Sub-test 1 using H-set 1 and QPSK. HSPA is configured according to E-DCH Subtest 5 requirements. SAR for other HSPA sub-test configurations is also confirmed selectively according to output power, exposure conditions and E-DCH UE Category. Maximum output power is verified according to procedures in applicable versions of 3GPP TS 34.121 and SAR must be measured according to these maximum output conditions. The UE Categories for HSDPCCH and HSPA should be clearly identified in the SAR report. The following procedures are applicable only if Maximum Power Reduction (MPR) is implemented according to Cubic Metric (CM) requirements.

When voice transmission and head exposure conditions are applicable to a WCDMA/HSPA data device, head exposure is measured according to the 'Head SAR Measurements' procedures in the 'WCDMA Handsets' section of this document. SAR for body exposure configurations are measured according to the 'Body SAR Measurements' procedures in the 'WCDMA Handsets' section of this document. In addition, body SAR is also measured for HSPA when the maximum average output of each RF channel with HSPA active is at least ¼ dB higher than that measured without HSPA using 12.2 kbps RMC or the maximum SAR for 12.2 kbps RMC is above 75% of the SAR limit. Body SAR for HSPA is measured with E-DCH Sub-test 5, using H-Set 1 and QPSK for FRC and a 12.2 kbps RMC configured in Test Loop Mode 1 with power control algorithm 2, according to the highest body SAR configuration in 12.2 kbps RMC without HSPA. When VOIP is applicable for head exposure, SAR is not required when the maximum output of each RF channel with HSPA is less than ¼ dB higher than that measured using 12.2 kbps RMC; otherwise, the same HSPA configuration used for body measurements should be used to test for head exposure.

Due to inner loop power control requirements in HSPA, a commercial communication test set should be used for the output power and SAR tests. The 12.2 kbps RMC, FRC H-set 1 and E-DCH configurations for HSPA should be configured according to the  $\beta$  values indicated below as well as other applicable procedures described in the 'WCDMA Handset' and 'Release 5 HSDPA Data Devices' sections of this document.



The highest body SAR measured in Antenna Extended & Retracted configurations on a channel in 12.2 kbps RMC. The possible channels are the High, Middle & Low channel. Contact the FCC Laboratory for test and approval requirements if the maximum output power measured in E-DCH Sub-test 2 - 4 is higher than Sub-test 5.

Setup for Release 6 HSPA / Release 7 HSPA+													
Sub-test	$\beta_c$	$\beta_d$	$\beta_d$ (SF)	$\beta_c/\beta_d$	$\beta_{hs}^{(1)}$	$\beta_{ec}$	$\beta_{ed}$	Bed (SF)	Bed (codes)	CM <sup>(2)</sup> (dB)	MPR (dB)	AG <sup>(4)</sup> Index	E-TFCI
1	11/15 <sup>(3)</sup>	15/15 <sup>(3)</sup>	64	11/15 <sup>(3)</sup>	22/15	209/225	1039/225	4	1	1.0	0.0	20	75
2	6/15	15/15	64	6/15	12/15	12/15	94/75	4	1	3.0	2.0	12	67
3	15/15	9/15	64	15/9	30/15	30/15	$\beta_{ed1}$ : 47/15 $\beta_{ed2}$ : 47/15	4	2	2.0	1.0	15	92
4	2/15	15/15	64	2/15	4/15	2/15	56/75	4	1	3.0	2.0	17	71
5	15/15 <sup>(4)</sup>	15/15 <sup>(4)</sup>	64	15/15 <sup>(4)</sup>	30/15	24/15	134/15	4	1	1.0	0.0	21	81

Note

- $\Delta_{ACK}$ ,  $\Delta_{NACK}$  and  $\Delta_{CQI} = 8 \Leftrightarrow A_{hs} = \beta_{hs}/\beta_c = 30/15 \Leftrightarrow \beta_{hs} = 30/15 * \beta_c$ .
- CM = 1 for  $\beta_c/\beta_d = 12/15$ ,  $\beta_{hs}/\beta_c = 24/15$ . For all other combinations of DPDCH, DPCCH, HS-DPCCH, E-DPDCH and E-DPCCH the MPR is based on the relative CM difference.
- For subtest 1 the  $\beta_c/\beta_d$  ratio of 11/15 for the TFC during the measurement period (TF1, TF0) is achieved by setting the signaled gain factors for the reference TFC (TF1, TF1) to  $\beta_c = 10/15$  and  $\beta_d = 15/15$ .
- For subtest 5 the  $\beta_c/\beta_d$  ratio of 15/15 for the TFC during the measurement period (TF1, TF0) is achieved by setting the signaled gain factors for the reference TFC (TF1, TF1) to  $\beta_c = 14/15$  and  $\beta_d = 15/15$ .
- Testing UE using E-DPDCH Physical Layer category 1 Sub-test 3 is not required according to TS 25.306 Table 5.1g.
- $\beta_{ed}$  can not be set directly; it is set by Absolute Grant Value.



### 6.3 SAR Testing with LTE-FDD Transmitters

All SAR measurements for LTE were performed using the Anritsu MT8820C. A closed loop power control setting allowed the UE to transmit at the maximum output power during the SAR measurements. Configure the basestation to support LTE tests in respect to the 3GPP 36.521-1, and set ch , RB allocation number , RB allocation offset , and send continuously Up power control commands to the device.

MPR was enabled for this device. A-MPR was disabled for all SAR test measurements.

### 6.4 LTE Frequency range and channel bandwidth

Channel bandwidth support:

Band	BW (MHz)					
	1.4	3	5	10	15	20
LTE Band 2	V	V	V	V	V	V
LTE Band 4	V	V	V	V	V	V
LTE Band 5	V	V	V	V		
LTE Band 17			V	V		

LTE Band	Bandwidth (MHz)	Test frequency ID	N <sub>UL</sub>	Frequency of Uplink (MHz)
LTE Band 2	1.4	Low Range	18607	1850.7
		Mid Range	18900	1880.0
		High Range	19193	1909.3
	3	Low Range	18615	1851.5
		Mid Range	18900	1880.0
		High Range	19185	1908.5
	5	Low Range	18625	1852.5
		Mid Range	18900	1880.0
		High Range	19175	1907.5
	10	Low Range	18650	1855.0
		Mid Range	18900	1880.0
		High Range	19150	1905.0
	15	Low Range	18675	1857.5
		Mid Range	18900	1880.0
		High Range	19125	1902.5
20	Low Range	18700	1860.0	
	Mid Range	18900	1880.0	
	High Range	19100	1900.0	



LTE Band	Bandwidth (MHz)	Test frequency ID	N <sub>UL</sub>	Frequency of Uplink (MHz)
LTE Band 4	1.4	Low Range	19957	1710.7
		Mid Range	20175	1732.5
		High Range	20393	1754.3
	3	Low Range	19965	1711.5
		Mid Range	20175	1732.5
		High Range	20385	1753.5
	5	Low Range	19975	1712.5
		Mid Range	20175	1732.5
		High Range	20375	1752.5
	10	Low Range	20000	1715.0
		Mid Range	20175	1732.5
		High Range	20350	1750.0
	15	Low Range	20025	1717.5
		Mid Range	20175	1732.5
		High Range	20325	1747.5
20	Low Range	20050	1720.0	
	Mid Range	20175	1732.5	
	High Range	20300	1745.0	
LTE Band 5	1.4	Low Range	20407	824.7
		Mid Range	20525	836.5
		High Range	20643	848.3
	3	Low Range	20415	825.5
		Mid Range	20525	836.5
		High Range	20635	847.5
	5	Low Range	20425	826.5
		Mid Range	20525	836.5
		High Range	20625	846.5
10	Low Range	20450	829.0	
	Mid Range	20525	836.5	
	High Range	20600	844.0	
LTE Band 17	5	Low Range	23755	706.5
		Mid Range	23790	710.0
		High Range	23825	713.5
	10	Low Range	23780	709.0
		Mid Range	23790	710.0
		High Range	23800	711.0



#### 6.4.1 Maximum power reduction (MPR)

Identify the LTE voice/data requirements in each operating mode and exposure condition with respect to head and body test configurations, antenna locations, handset flip-cover or slide positions, antenna diversity conditions etc.

The voice and data transmission:

- ◆ Data only device.

Identify if Maximum Power Reduction (MPR) is optional or mandatory, i.e. built-in by design:

- ◆ Maximum Power Reduction (MPR) is mandatory, i.e. built-in by design.
- ◆ A-MPR (additional MPR) must be disabled
- ◆ A-MPR was disabled during testing.

Maximum Power Reduction (MPR) for Power Class 3							
Channel bandwidth / Transmission bandwidth configuration (RB)							
Modulation	1.4 MHz	3 MHz	5 MHz	10 MHz	15 MHz	20MHz	MPR (dB)
QPSK	> 5	> 4	> 8	> 12	> 16	> 18	≤ 1
16 QAM	≤ 5	≤ 4	≤ 8	≤ 12	≤ 16	≤ 18	≤ 1
16 QAM	> 5	> 4	> 8	> 12	> 16	> 18	≤ 2

#### 6.5 Power reduction

No power reduction issue.





## 6.6 SAR Testing with 802.11 Transmitters

Normal network operating configurations are not suitable for measuring the SAR of 802.11 b/g transmitters. Unpredictable fluctuations in network traffic and antenna diversity conditions can introduce undesirable variations in SAR results. The SAR for these devices should be measured using chipset based test mode software to ensure the results are consistent and reliable.

## 6.7 General Device Setup

Chipset based test mode software is hardware dependent and generally varies among manufacturers. The device operating parameters established in test mode for SAR measurements must be identical to those programmed in production units, including output power levels, amplifier gain settings and other RF performance tuning parameters. The test frequencies should correspond to actual channel frequencies defined for domestic use. SAR for devices with switched diversity should be measured with only one antenna transmitting at a time during each SAR measurement, according to a fixed modulation and data rate. The same data pattern should be used for all measurements.

### Frequency Channel Configurations

802.11 a/b/g and 4.9 GHz operating modes are tested independently according to the service requirements in each frequency band. 802.11 b/g modes are tested on channels 1, 6 and 11. 802.11a is tested for UNII operations on channels 36 and 48 in the 5.15-5.25 GHz band; channels 52 and 64 in the 5.25-5.35 GHz band; channels 104, 116, 124 and 136 in the 5.470-5.725 GHz band; and channels 149 and 161 in the 5.8 GHz band. When 5.8 GHz §15.247 is also available, channels 149, 157 and 165 should be tested instead of the UNII channels. 4.9 GHz is tested on channels 1, 10 and 5 or 6, whichever has the higher output power, for 5 MHz channels; channels 11, 15 and 19 for 10 MHz channels; and channels 21 and 25 for 20 MHz channels. These are referred to as the “default test channels”. 802.11g mode was evaluated only if the output power was 0.25 dB higher than the 802.11b mode.



IEEE 802.11 Test Channels per FCC Requirement								
Mode	GHz	Channel	Turbo Channel	Default Test "Channels"				
				§15.247		UNII		
				802.11b	802.11g			
IEEE 802.11 b/g	2412	1 <sup>#</sup>		✓	▽			
	2437	6	6	✓	▽			
	2462	11 <sup>#</sup>		✓	▽			
IEEE 802.11a	UNII	5.18	36				✓	
		5.20	40	42 (5.21 GHz)				*
		5.22	44					*
		5.24	48	50 (5.25 GHz)			✓	
		5.26	52				✓	
		5.28	56	58 (5.29 GHz)				*
		5.30	60					*
		5.32	64				✓	
		5.500	100	Unknown				*
		5.520	104				✓	
		5.540	108					*
		5.560	112					*
		5.580	116				✓	
		5.660	132					*
		5.680	136				✓	
		5.700	140					*
	UNII or §15.247	5.745	149		✓		✓	
		5.765	153	152 (5.76 GHz)		*		*
		5.785	157		✓			*
		5.805	161	160 (5.80 GHz)		*	✓	
§15.247	5.825	165		✓				

✓ = "default test channels"

\* = possible 802.11a channels with maximum average output > the "default test channels"

▽ = possible 802.11g channels with maximum average output ¼ dB ≥ the "default test channels"

# = when output power is reduced for channel 1 and/or 11 to meet restricted band requirements the



## 6.8 Conducted Power

Band	Modulation	Sub-test	CH	Frequency (MHz)	Burst Average Power (dBm)
WCDMA Band II	RMC12.2K	---	Lowest	1852.4	22.78
			Middle	1880.0	<b>22.79</b>
			Highest	1907.6	22.53
HSDPA Band II	QPSK	1	Lowest	1852.4	21.90
			Middle	1880.0	21.90
			Highest	1907.6	21.65
		2	Lowest	1852.4	21.86
			Middle	1880.0	21.87
			Highest	1907.6	21.61
		3	Lowest	1852.4	21.40
			Middle	1880.0	21.41
			Highest	1907.6	21.17
		4	Lowest	1852.4	21.38
			Middle	1880.0	21.37
			Highest	1907.6	21.14
HSUPA Band II	QPSK	1	Lowest	1852.4	21.30
			Middle	1880.0	21.32
			Highest	1907.6	21.06
		2	Lowest	1852.4	19.32
			Middle	1880.0	19.35
			Highest	1907.6	19.07
		3	Lowest	1852.4	20.33
			Middle	1880.0	20.35
			Highest	1907.6	20.07
		4	Lowest	1852.4	19.27
			Middle	1880.0	19.31
			Highest	1907.6	19.06
		5	Lowest	1852.4	21.27
			Middle	1880.0	21.30
			Highest	1907.6	21.02



Band	Modulation	Sub-test	CH	Frequency (MHz)	Burst Average Power (dBm)
WCDMA Band V	RMC12.2K	---	Lowest	826.4	23.21
			Middle	836.6	23.11
			Highest	846.6	<b>23.26</b>
HSDPA Band V	QPSK	1	Lowest	826.4	22.34
			Middle	836.6	22.22
			Highest	846.6	22.38
		2	Lowest	826.4	22.31
			Middle	836.6	22.20
			Highest	846.6	22.34
		3	Lowest	826.4	21.86
			Middle	836.6	21.73
			Highest	846.6	21.91
		4	Lowest	826.4	21.83
			Middle	836.6	21.70
			Highest	846.6	21.88
HSUPA Band V	QPSK	1	Lowest	826.4	22.09
			Middle	836.6	22.01
			Highest	846.6	22.16
		2	Lowest	826.4	20.11
			Middle	836.6	20.04
			Highest	846.6	20.17
		3	Lowest	826.4	21.11
			Middle	836.6	21.04
			Highest	846.6	21.17
		4	Lowest	826.4	20.08
			Middle	836.6	19.99
			Highest	846.6	20.13
		5	Lowest	826.4	22.05
			Middle	836.6	21.98
			Highest	846.6	22.14



Band	Channel Bandwidth	Modulation	Channel	Frequency (MHz)	RB Configuration		Burst Average Power (dBm)
					Size	Offset	
LTE Band 2	1.4 MHz	QPSK	18607	1850.7	1	0	22.52
					1	2	22.45
					1	5	22.39
					3	0	22.57
					3	1	22.55
					3	3	22.42
			6	0	21.44		
			1	0	22.60		
			1	2	22.63		
			1	5	22.62		
			3	0	22.63		
			3	1	22.59		
			3	3	22.56		
			6	0	21.63		
			1	0	22.22		
			1	2	22.24		
			1	5	22.27		
			3	0	22.19		
		3	1	22.23			
		3	3	22.26			
		6	0	21.27			
		1	0	21.57			
		1	2	21.51			
		1	5	21.53			
		3	0	21.46			
		3	1	21.43			
		3	3	21.46			
		6	0	20.53			
		1	0	21.59			
		1	2	21.55			
		1	5	21.56			
		3	0	21.58			
		3	1	21.62			
		3	3	21.60			
		6	0	20.70			
		1	0	21.53			
1	2	21.57					
1	5	21.52					
3	0	21.23					
3	1	21.20					
3	3	21.24					
6	0	20.53					



Band	Channel Bandwidth	Modulation	Channel	Frequency (MHz)	RB Configuration		Burst Average Power (dBm)		
					Size	Offset			
LTE Band 2	3MHz	QPSK	18615	1851.5	1	0	22.39		
					1	7	22.28		
					1	14	22.23		
					8	0	21.36		
					8	3	21.36		
					8	7	21.30		
			15	0	21.29				
			1	0	22.47				
			1	7	22.51				
			1	14	22.50				
			8	0	21.55				
			8	3	21.54				
			8	7	21.58				
			15	0	21.56				
			1	0	22.04				
			1	7	22.10				
			1	14	22.21				
			8	0	21.08				
		8	3	21.07					
		8	7	21.13					
		15	0	21.06					
		1	0	21.31					
		1	7	21.25					
		1	14	21.17					
		8	0	20.25					
		8	3	20.22					
		8	7	20.20					
		15	0	20.27					
		1	0	21.42					
		1	7	21.46					
		1	14	21.51					
		8	0	20.51					
		8	3	20.52					
		8	7	20.54					
		15	0	20.60					
		1	0	21.01					
		1	7	21.07					
		1	14	21.08					
		8	0	20.06					
		8	3	20.05					
		8	7	20.05					
		15	0	20.17					
		16QAM	18615	1851.5	18615	1851.5	1	0	21.31
							1	7	21.25
							1	14	21.17
							8	0	20.25
							8	3	20.22
							8	7	20.20
15	0		20.27						
1	0		21.42						
1	7		21.46						
1	14		21.51						
8	0		20.51						
8	3		20.52						
8	7		20.54						
15	0		20.60						
1	0		21.01						
1	7		21.07						
1	14		21.08						
8	0		20.06						
8	3	20.05							
8	7	20.05							
15	0	20.17							



Band	Channel Bandwidth	Modulation	Channel	Frequency (MHz)	RB Configuration		Burst Average Power (dBm)
					Size	Offset	
LTE Band 2	5MHz	QPSK	18625	1852.5	1	0	22.40
					1	12	22.26
					1	24	22.18
					12	0	21.33
					12	6	21.31
					12	13	21.26
			25	0	21.21		
			1	0	22.43		
			1	12	22.52		
			1	24	22.53		
			12	0	21.54		
			12	6	21.53		
			12	13	21.53		
			25	0	21.48		
			1	0	22.06		
			1	12	22.08		
			1	24	22.25		
			12	0	21.05		
		12	6	21.03			
		12	13	21.07			
		25	0	21.00			
		1	0	21.42			
		1	12	21.21			
		1	24	21.15			
		12	0	20.33			
		12	6	20.27			
		12	13	20.22			
		25	0	20.17			
		1	0	21.42			
		1	12	21.48			
		1	24	21.52			
		12	0	20.58			
		12	6	20.63			
		12	13	20.68			
		25	0	20.55			
		1	0	21.01			
1	12	21.05					
1	24	21.17					
12	0	20.13					
12	6	20.16					
12	11	20.18					
25	0	20.04					



Band	Channel Bandwidth	Modulation	Channel	Frequency (MHz)	RB Configuration		Burst Average Power (dBm)
					Size	Offset	
LTE Band 2	10MHz	QPSK	18650	1855.0	1	0	22.34
					1	24	22.16
					1	49	22.18
					25	0	21.18
					25	12	21.11
					25	25	21.15
			50	0	21.09		
			1	0	22.34		
			1	24	22.48		
			1	49	22.45		
			25	0	21.45		
			25	12	21.44		
			25	25	21.56		
			50	0	21.40		
			1	0	22.05		
			1	24	22.01		
			1	49	22.18		
			25	0	21.04		
		25	12	21.04			
		25	25	21.05			
		50	0	20.96			
		1	0	21.38			
		1	24	21.13			
		1	49	21.13			
		25	0	20.14			
		25	12	20.07			
		25	25	20.04			
		50	0	20.06			
		1	0	21.38			
		1	24	21.47			
		1	49	21.39			
		25	0	20.46			
		25	12	20.49			
		25	25	20.59			
		50	0	20.45			
		1	0	21.08			
1	24	21.01					
1	49	21.15					
25	0	20.07					
25	12	20.07					
25	25	20.08					
50	0	20.01					





Band	Channel Bandwidth	Modulation	Channel	Frequency (MHz)	RB Configuration		Burst Average Power (dBm)
					Size	Offset	
LTE Band 2	15MHz	QPSK	18675	1857.5	1	0	22.41
					1	37	22.18
					1	74	22.35
					36	0	21.23
					36	19	21.17
					36	39	21.20
			18900	1880	75	0	21.14
					1	0	22.69
					1	37	22.54
					1	74	22.48
					36	0	21.37
					36	19	21.53
			19125	1902.5	36	39	21.50
					75	0	21.44
					1	0	22.29
					1	37	22.14
					1	74	22.30
					36	0	21.06
		16QAM	18675	1857.5	36	19	21.03
					36	39	21.08
					75	0	20.99
					1	0	21.37
					1	37	21.17
					1	74	21.36
			18900	1880	36	0	20.16
					36	19	20.14
					36	39	20.20
					75	0	20.12
					1	0	21.59
					1	37	21.53
			19125	1902.5	1	74	21.38
					36	0	20.48
					36	19	20.62
					36	39	20.64
					75	0	20.49
					1	0	21.25
19125	1902.5	1	37	21.05			
		1	74	21.25			
		36	0	20.19			
		36	19	20.10			
		36	39	20.11			
		75	0	20.07			



Band	Channel Bandwidth	Modulation	Channel	Frequency (MHz)	RB Configuration		Burst Average Power (dBm)
					Size	Offset	
LTE Band 2	20MHz	QPSK	18700	1860	1	0	22.38
					1	49	22.20
					1	99	<b>22.80</b>
					50	0	21.16
					50	25	21.11
					50	50	21.25
			100	0	21.27		
			1	0	22.72		
			1	49	22.54		
			1	99	22.48		
			50	0	21.48		
			50	25	21.50		
			50	50	21.55		
			100	0	21.43		
			1	0	22.41		
			1	49	22.15		
			1	99	22.22		
			50	0	21.17		
		50	25	21.03			
		50	50	21.03			
		100	0	21.05			
		1	0	21.44			
		1	49	21.22			
		1	99	21.74			
		50	0	20.12			
		50	25	20.10			
		50	50	20.26			
		100	0	20.15			
		1	0	21.79			
		1	49	21.57			
		1	99	21.48			
		50	0	20.47			
		50	25	20.52			
		50	50	20.58			
		100	0	20.51			
		1	0	21.46			
1	49	21.13					
1	99	21.19					
50	0	20.24					
50	25	20.07					
50	50	20.04					
100	0	20.20					



Band	Channel Bandwidth	Modulation	Channel	Frequency (MHz)	RB Configuration		Burst Average Power (dBm)
					Size	Offset	
LTE Band 4	1.4MHz	QPSK	19957	1710.7	1	0	21.96
					1	2	22.01
					1	5	22.02
					3	0	21.99
					3	1	22.03
					3	3	22.03
			6	0	21.07		
			1	0	22.16		
			1	2	22.18		
			1	5	22.21		
			3	0	22.20		
			3	1	22.23		
			3	3	22.20		
			6	0	21.23		
			1	0	22.06		
			1	2	22.07		
			1	5	22.05		
			3	0	22.08		
		3	1	22.05			
		3	3	22.01			
		6	0	21.08			
		1	0	21.57			
		1	2	21.55			
		1	5	21.55			
		3	0	21.06			
		3	1	21.03			
		3	3	21.10			
		6	0	20.56			
		1	0	21.12			
		1	2	21.20			
		1	5	21.17			
		3	0	21.26			
		3	1	21.23			
		3	3	21.23			
		6	0	20.27			
		1	0	21.52			
1	2	21.55					
1	5	21.53					
3	0	21.10					
3	1	21.09					
3	3	21.06					
6	0	20.52					



Band	Channel Bandwidth	Modulation	Channel	Frequency (MHz)	RB Configuration		Burst Average Power (dBm)
					Size	Offset	
LTE Band 4	3MHz	QPSK	19965	1711.5	1	0	21.98
					1	7	22.01
					1	14	22.05
					8	0	21.03
					8	3	21.07
					8	7	21.12
			15	0	21.05		
			1	0	22.17		
			1	7	22.20		
			1	14	22.19		
			8	0	21.26		
			8	3	21.25		
			8	7	21.20		
			15	0	21.17		
			1	0	22.09		
			1	7	22.04		
			1	14	22.03		
			8	0	21.08		
		8	3	21.05			
		8	7	21.09			
		15	0	21.10			
		1	0	21.00			
		1	7	21.03			
		1	14	21.10			
		8	0	19.98			
		8	3	19.98			
		8	7	19.98			
		15	0	20.07			
		1	0	21.17			
		1	7	21.17			
		1	14	21.18			
		8	0	20.17			
		8	3	20.19			
		8	7	20.18			
		15	0	20.23			
		1	0	21.10			
1	7	21.05					
1	14	21.01					
8	0	20.07					
8	3	20.02					
8	7	19.98					
15	0	20.08					



Band	Channel Bandwidth	Modulation	Channel	Frequency (MHz)	RB Configuration		Burst Average Power (dBm)
					Size	Offset	
LTE Band 4	5MHz	QPSK	19975	1712.5	1	0	21.97
					1	12	22.06
					1	24	22.14
					12	0	21.07
					12	6	21.14
					12	13	21.11
			25	0	21.11		
			1	0	22.13		
			1	12	22.15		
			1	24	22.21		
			12	0	21.20		
			12	6	21.28		
			12	13	21.27		
			25	0	21.24		
			1	0	22.03		
			1	12	22.06		
			1	24	21.96		
			12	0	21.20		
		12	6	21.16			
		12	13	21.08			
		25	0	21.02			
		1	0	20.99			
		1	12	21.06			
		1	24	21.18			
		12	0	20.07			
		12	6	20.14			
		12	13	20.13			
		25	0	20.01			
		1	0	21.16			
		1	12	21.18			
		1	24	21.23			
		12	0	20.25			
		12	6	20.26			
		12	13	20.25			
		25	0	20.21			
		1	0	21.03			
1	12	21.08					
1	24	20.97					
12	0	20.17					
12	6	20.17					
12	11	20.08					
25	0	20.09					



Band	Channel Bandwidth	Modulation	Channel	Frequency (MHz)	RB Configuration		Burst Average Power (dBm)
					Size	Offset	
LTE Band 4	10MHz	QPSK	20000	1715.0	1	0	21.96
					1	24	22.15
					1	49	22.16
					25	0	21.10
					25	12	21.16
					25	25	21.23
			50	0	21.11		
			1	0	22.12		
			1	24	22.18		
			1	49	22.11		
			25	0	21.15		
			25	12	21.24		
			25	25	21.26		
			50	0	21.10		
			1	0	22.04		
			1	24	22.03		
			1	49	22.00		
			25	0	21.12		
		25	12	21.11			
		25	25	21.06			
		50	0	20.97			
		1	0	21.04			
		1	24	21.22			
		1	49	21.24			
		25	0	20.03			
		25	12	20.16			
		25	25	20.21			
		50	0	20.08			
		1	0	21.10			
		1	24	21.21			
		1	49	21.08			
		25	0	20.13			
		25	12	20.21			
		25	25	20.23			
		50	0	20.15			
		1	0	21.03			
1	24	21.00					
1	49	20.99					
25	0	20.11					
25	12	20.12					
25	25	20.11					
50	0	19.97					



Band	Channel Bandwidth	Modulation	Channel	Frequency (MHz)	RB Configuration		Burst Average Power (dBm)
					Size	Offset	
LTE Band 4	15MHz	QPSK	20025	1717.5	1	0	22.03
					1	37	22.11
					1	74	22.14
					36	0	21.05
					36	19	21.19
					36	39	21.19
			20175	1732.5	75	0	21.12
					1	0	22.16
					1	37	22.17
					1	74	22.13
					36	0	21.13
					36	19	21.08
			20325	1747.5	36	39	21.15
					75	0	21.11
					1	0	22.19
					1	37	22.12
					1	74	22.00
					36	0	21.14
		16QAM	20025	1717.5	36	19	20.99
					36	39	21.05
					75	0	20.96
					1	0	21.04
					1	37	21.17
					1	74	21.18
			20175	1732.5	36	0	20.10
					36	19	20.21
					36	39	20.13
					75	0	20.01
					1	0	21.19
					1	37	21.20
			20325	1747.5	1	74	21.08
					36	0	20.11
					36	19	20.15
					36	39	20.19
					75	0	20.07
					1	0	21.15
20025	1717.5	1	37	21.13			
		1	74	20.97			
		36	0	20.11			
		36	19	20.04			
		36	39	20.07			
		75	0	20.01			



Band	Channel Bandwidth	Modulation	Channel	Frequency (MHz)	RB Configuration		Burst Average Power (dBm)
					Size	Offset	
LTE Band 4	20MHz	QPSK	20050	1720.0	1	0	22.17
					1	49	<b>22.37</b>
					1	99	22.21
					50	0	21.30
					50	25	21.30
					50	50	21.32
			100	0	21.23		
			1	0	22.36		
			1	49	22.34		
			1	99	22.23		
			50	0	21.36		
			50	25	21.32		
			50	50	21.28		
			100	0	21.33		
			1	0	22.31		
			1	49	22.17		
			1	99	22.11		
			50	0	21.34		
		50	25	21.20			
		50	50	21.09			
		100	0	21.14			
		1	0	21.25			
		1	49	21.43			
		1	99	21.25			
		50	0	20.27			
		50	25	20.28			
		50	50	20.30			
		100	0	20.22			
		1	0	21.40			
		1	49	21.34			
		1	99	21.28			
		50	0	20.33			
		50	25	20.27			
		50	50	20.35			
		100	0	20.28			
		1	0	21.39			
1	49	21.18					
1	99	21.12					
50	0	20.28					
50	25	20.19					
50	50	20.07					
100	0	20.21					





Band	Channel Bandwidth	Modulation	Channel	Frequency (MHz)	RB Configuration		Burst Average Power (dBm)
					Size	Offset	
LTE Band 5	1.4MHz	QPSK	20407	824.7	1	0	22.93
					1	2	22.94
					1	5	23.05
					3	0	22.93
					3	1	23.00
					3	3	22.94
			6	0	22.03		
			1	0	23.02		
			1	2	22.97		
			1	5	22.99		
			3	0	23.03		
			3	1	23.02		
			3	3	23.00		
			6	0	22.08		
			1	0	23.28		
			1	2	23.20		
			1	5	23.15		
			3	0	23.23		
		3	1	23.27			
		3	3	23.16			
		6	0	22.35			
		1	0	21.99			
		1	2	21.91			
		1	5	21.94			
		3	0	21.96			
		3	1	22.02			
		3	3	22.01			
		6	0	21.12			
		1	0	22.03			
		1	2	22.02			
		1	5	22.01			
		3	0	22.09			
		3	1	22.08			
		3	3	22.12			
		6	0	21.12			
		1	0	22.24			
1	2	22.23					
1	5	22.16					
3	0	22.32					
3	1	22.23					
3	3	22.25					
6	0	21.34					



Band	Channel Bandwidth	Modulation	Channel	Frequency (MHz)	RB Configuration		Burst Average Power (dBm)
					Size	Offset	
LTE Band 5	3MHz	QPSK	20415	825.5	1	0	23.08
					1	7	23.05
					1	14	22.99
					8	0	21.99
					8	3	22.14
					8	7	21.95
			15	0	22.00		
			1	0	23.09		
			1	7	23.03		
			1	14	23.08		
			8	0	22.11		
			8	3	22.09		
			8	7	22.10		
			15	0	22.04		
			1	0	<b>23.30</b>		
			1	7	23.29		
			1	14	23.21		
			8	0	22.31		
		8	3	22.19			
		8	7	22.32			
		15	0	22.19			
		1	0	21.94			
		1	7	21.01			
		1	14	21.89			
		8	0	21.01			
		8	3	21.11			
		8	7	21.01			
		15	0	21.06			
		1	0	22.06			
		1	7	22.05			
		1	14	22.04			
		8	0	21.03			
		8	3	21.02			
		8	7	21.06			
		15	0	21.08			
		1	0	22.26			
		1	7	22.17			
		1	14	22.19			
		8	0	21.14			
		8	3	21.19			
		8	7	21.20			
		15	0	21.24			



Band	Channel Bandwidth	Modulation	Channel	Frequency (MHz)	RB Configuration		Burst Average Power (dBm)
					Size	Offset	
LTE Band 5	5MHz	QPSK	20425	826.5	1	0	23.03
					1	12	22.90
					1	24	22.99
					12	0	22.10
					12	6	21.92
					12	13	21.90
			20525	836.5	25	0	21.82
					1	0	23.10
					1	12	23.03
					1	24	23.07
					12	0	22.09
					12	6	22.08
			20625	846.5	12	13	22.01
					25	0	22.01
					1	0	23.26
					1	12	23.12
					1	24	23.18
					12	0	22.23
		16QAM	20425	826.5	12	6	22.27
					12	13	22.29
					25	0	22.18
					1	0	21.93
					1	12	21.85
					1	24	21.88
			20525	836.5	12	0	21.17
					12	6	21.04
					12	13	20.97
					25	0	20.92
					1	0	22.07
					1	12	22.04
			20625	846.5	1	24	22.06
					12	0	21.08
					12	6	21.09
					12	13	21.08
					25	0	21.00
					1	0	22.22
20625	846.5	1	12	22.03			
		1	24	22.15			
		12	0	21.27			
		12	6	21.30			
		12	13	21.35			
		25	0	21.18			



Band	Channel Bandwidth	Modulation	Channel	Frequency (MHz)	RB Configuration		Burst Average Power (dBm)
					Size	Offset	
LTE Band 5	10MHz	QPSK	20450	829.0	1	0	23.06
					1	24	22.93
					1	49	22.96
					25	0	21.95
					25	12	21.79
					25	25	21.90
			50	0	21.83		
			1	0	23.09		
			1	24	23.01		
			1	49	23.08		
			25	0	21.96		
			25	12	21.96		
			25	25	22.00		
			50	0	21.81		
			1	0	23.22		
			1	24	23.07		
			1	49	23.13		
			25	0	22.13		
		25	12	22.11			
		25	25	22.12			
		50	0	21.98			
		1	0	22.03			
		1	24	21.91			
		1	49	21.92			
		25	0	20.98			
		25	12	20.92			
		25	25	20.93			
		50	0	20.88			
		1	0	22.11			
		1	24	21.99			
		1	49	22.04			
		25	0	21.00			
		25	12	21.00			
		25	25	20.97			
		50	0	20.92			
		1	0	22.16			
1	24	22.15					
1	49	22.14					
25	0	21.13					
25	12	21.07					
25	25	21.19					
50	0	21.06					



Band	Channel Bandwidth	Modulation	Channel	Frequency (MHz)	RB Configuration		Burst Average Power (dBm)
					Size	Offset	
LTE Band 17	5MHz	QPSK	23755	706.5	1	0	23.89
					1	12	23.80
					1	24	23.88
					12	0	22.89
					12	6	22.90
					12	13	22.81
			25	0	22.66		
			1	0	23.84		
			1	12	23.79		
			1	24	23.78		
			12	0	22.76		
			12	6	22.84		
			12	13	22.79		
			25	0	22.75		
			1	0	23.79		
			1	12	23.74		
			1	24	23.66		
			12	0	22.75		
		12	6	22.72			
		12	13	22.63			
		25	0	22.67			
		1	0	22.84			
		1	12	22.79			
		1	24	22.78			
		12	0	21.86			
		12	6	21.88			
		12	13	21.79			
		25	0	21.72			
		1	0	22.85			
		1	12	22.79			
		1	24	22.77			
		12	0	21.84			
		12	6	21.87			
		12	13	21.82			
		25	0	21.77			
		1	0	22.76			
1	12	22.75					
1	24	22.66					
12	0	21.79					
12	6	21.80					
12	13	21.73					
25	0	21.64					



Band	Channel Bandwidth	Modulation	Channel	Frequency (MHz)	RB Configuration		Burst Average Power (dBm)
					Size	Offset	
LTE Band 17	10MHz	QPSK	23780	709.0	1	0	<b>23.93</b>
					1	24	23.89
					1	49	23.91
					25	0	22.74
					25	12	22.76
					25	25	22.73
			50	0	22.61		
			1	0	23.87		
			1	24	23.82		
			1	49	23.80		
			25	0	22.70		
			25	12	22.79		
			25	25	22.77		
			50	0	22.65		
			1	0	23.78		
			1	24	23.75		
			1	49	23.72		
			25	0	22.64		
		25	12	22.73			
		25	25	22.69			
		50	0	22.55			
		1	0	22.77			
		1	24	22.74			
		1	49	22.72			
		25	0	21.66			
		25	12	21.67			
		25	25	21.70			
		50	0	21.53			
		1	0	22.75			
		1	24	22.70			
		1	49	22.69			
		25	0	21.60			
		25	12	21.69			
		25	25	21.75			
		50	0	21.53			
		1	0	22.73			
1	24	22.71					
1	49	22.62					
25	0	21.66					
25	12	21.71					
25	25	21.65					
50	0	21.53					



Band	Data Rate	CH	Frequency (MHz)	Average Power (dBm)
IEEE 802.11b	1M	1	2412.0	<b>9.85</b>
		6	2437.0	9.66
		11	2462.0	9.64
	2M	6	2437.0	9.61
	5.5M	6	2437.0	9.60
IEEE 802.11g	6M	1	2412.0	9.59
		6	2437.0	9.40
		11	2462.0	<b>9.70</b>
	9M	6	2437.0	9.31
	12M	6	2437.0	9.30
	18M	6	2437.0	9.24
	24M	6	2437.0	9.33
	36M	6	2437.0	9.25
	48M	6	2437.0	9.22
	54M	6	2437.0	9.23
IEEE 802.11n 20MHz (2.4 GHz)	6.5M	1	2412.0	9.89
		6	2437.0	<b>9.93</b>
		11	2462.0	9.75
	13M	6	2437.0	9.85
	19.5M	6	2437.0	9.78
	26M	6	2437.0	9.79
	39M	6	2437.0	9.82
	52M	6	2437.0	9.75
	58.5M	6	2437.0	9.71
	65M	6	2437.0	9.75
IEEE 802.11n 40MHz (2.4 GHz)	13.5M	3	2422.0	9.23
		6	2437.0	<b>9.38</b>
		9	2452.0	9.17
	27M	6	2437.0	9.31
	40.5M	6	2437.0	9.23
	54M	6	2437.0	9.27
	81M	6	2437.0	9.18
	108M	6	2437.0	9.21
	121.5M	6	2437.0	9.23
135M	6	2437.0	9.29	

## 6.9 Antenna location

Antenna-User			
Distance of WWAN to edge		Distance of WLAN to edge	
WWAN to Side 1	2.1 mm	WLAN to Side 1	1.9 mm
WWAN to Side 2	3.4 mm	WLAN to Side 2	10.6 mm
WWAN to Side 3	11.2 mm	WLAN to Side 3	2.5 mm
WWAN to Side 4	10.4 mm	WLAN to Side 4	59.0 mm
WWAN to Side 5	3.5 mm	WLAN to Side 5	24.4 mm
WWAN to Side 6	91.0 mm	WLAN to Side 6	56.4 mm
Antenna-Antenna			
Antenna account		Distance (mm)	
WWAN to WLAN		3.1	

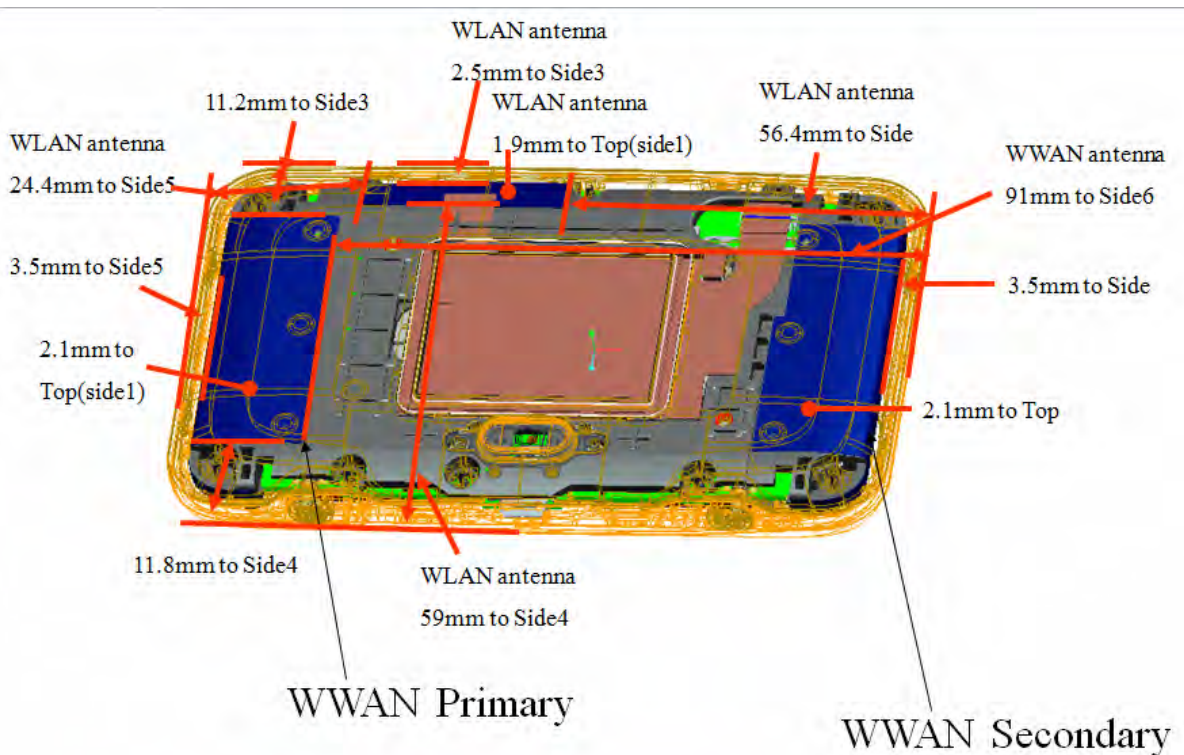

## Top side of Device



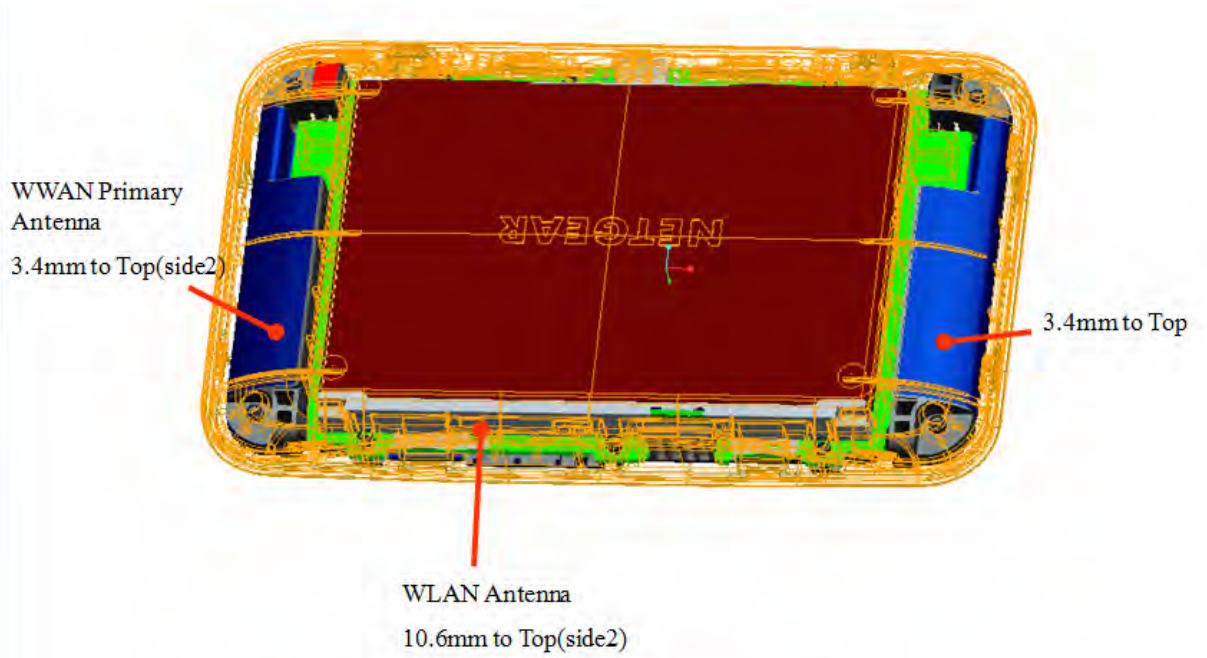

## Bottom side of Device



## 6.10 Stand-alone SAR Evaluate

Transmitter and antenna implementation as below:

Band	WWAN Main antenna	WLAN antenna
WWAN	V	X
WLAN	X	V

Stand-alone transmission configurations as below:

Band	Side 1	Side 2	Side 3	Side 4	Side 5	Side 6
WCDMA/HSDPA/HSUPA Band II	V	V	V	V	V	-
WCDMA/HSDPA/HSUPA Band V	V	V	V	V	V	-
LTE Band 2	V	V	V	V	V	-
LTE Band 4	V	V	V	V	V	-
LTE Band 5	V	V	V	V	V	-
LTE Band 17	V	V	V	V	V	-
IEEE 802.11b	V	-	V	-	-	-

Note: The "-" on behalf of Stand-alone SAR is not required (Refer to KDB447498 D01v05r02 4.3.1 for the Standalone SAR test exclusion considerations)

Antenna	Side	Band	Channel	Power (dBm)	Frequency (GHz)	Distance (mm)	Power (mW)	Result	Limit	Exclusion Considerations SAR <sup>19</sup>
WWAN	1	WCDMA Band II	9400	23.0	1.880	5.0	200	54.80	3	SAR is required
		WCDMA Band V	4233	24.0	0.847	5.0	251	46.20	3	SAR is required
		LTE Band 2	18700	23.5	1.860	5.0	224	61.10	3	SAR is required
		LTE Band 4	20050	23.0	1.720	5.0	200	52.50	3	SAR is required
		LTE Band 5	20600	24.0	0.844	5.0	251	46.10	3	SAR is required
		LTE Band 17	23780	24.0	0.709	5.0	251	42.30	3	SAR is required
WLAN		IEEE 802.11b	1	10.0	2.412	5.0	10	3.10	3	SAR is required
WWAN	2	WCDMA Band II	9400	23.0	1.880	5.0	200	54.80	3	SAR is required
		WCDMA Band V	4233	24.0	0.847	5.0	251	46.20	3	SAR is required
		LTE Band 2	18700	23.5	1.860	5.0	224	61.10	3	SAR is required
		LTE Band 4	20050	23.0	1.720	5.0	200	52.50	3	SAR is required
		LTE Band 5	20600	24.0	0.844	5.0	251	46.10	3	SAR is required
		LTE Band 17	23780	24.0	0.709	5.0	251	42.30	3	SAR is required
WLAN		IEEE 802.11b	1	10.0	2.412	10.6	10	1.50	3	SAR is not required



Antenna	Side	Band	Channel	Power (dBm)	Frequency (GHz)	Distance (mm)	Power (mW)	Result	Limit	Exclusion Considerations SAR <sup>19</sup>
WWAN	3	WCDMA Band II	9400	23.0	1.880	11.2	200	24.50	3	SAR is required
		WCDMA Band V	4233	24.0	0.847	11.2	251	20.60	3	SAR is required
		LTE Band 2	18700	23.5	1.860	11.2	224	27.30	3	SAR is required
		LTE Band 4	20050	23.0	1.720	11.2	200	23.40	3	SAR is required
		LTE Band 5	20600	24.0	0.844	11.2	251	20.60	3	SAR is required
		LTE Band 17	23780	24.0	0.709	11.2	251	18.90	3	SAR is required
WLAN		IEEE 802.11b	1	10.0	2.412	5.0	10	3.10	3	SAR is required
WWAN	4	WCDMA Band II	9400	23.0	1.880	10.4	200	26.40	3	SAR is required
		WCDMA Band V	4233	24.0	0.847	10.4	251	22.20	3	SAR is required
		LTE Band 2	18700	23.5	1.860	10.4	224	29.40	3	SAR is required
		LTE Band 4	20050	23.0	1.720	10.4	200	25.20	3	SAR is required
		LTE Band 5	20600	24.0	0.844	10.4	251	22.20	3	SAR is required
		LTE Band 17	23780	24.0	0.709	10.4	251	20.30	3	SAR is required
WWAN	5	WCDMA Band II	9400	23.0	1.880	5.0	200	54.80	3	SAR is required
		WCDMA Band V	4233	24.0	0.847	5.0	251	46.20	3	SAR is required
		LTE Band 2	18700	23.5	1.860	5.0	224	61.10	3	SAR is required
		LTE Band 4	20050	23.0	1.720	5.0	200	52.50	3	SAR is required
		LTE Band 5	20600	24.0	0.844	5.0	251	46.10	3	SAR is required
		LTE Band 17	23780	24.0	0.709	5.0	251	42.30	3	SAR is required
WLAN		IEEE 802.11b	1	10.0	2.412	24.4	10	0.60	3	SAR is not required

Antenna	Side	Band	Channel	Power (dBm)	Frequency (GHz)	Distance (mm)	Power (mW)	Power Thresholds (mW)	Exclusion Considerations SAR <sup>19</sup>
								SAR <sup>19</sup>	
WLAN	4	IEEE 802.11b	1	10.0	2.412	59.0	10	187	SAR is not required
WWAN	6	WCDMA Band II	9400	23.0	1.880	91.0	200	519	SAR is not required
		WCDMA Band V	4233	24.0	0.847	91.0	251	394	SAR is not required
		LTE Band 2	18700	23.5	1.860	91.0	224	520	SAR is not required
		LTE Band 4	20050	23.0	1.720	91.0	200	524	SAR is not required
		LTE Band 5	20600	24.0	0.844	91.0	251	394	SAR is not required
		LTE Band 17	23780	24.0	0.709	91.0	251	372	SAR is not required
WLAN		IEEE 802.11b	1	10.0	2.412	56.4	10	161	SAR is not required



## 6.11 Simultaneous Transmitting Evaluate

Simultaneous transmission configurations as below:

Condition	Side	Frequency Band	
		WWAN Antenna	WLAN Antenna
1	1	V	V
2	2	V	V
3	3	V	V
4	4	V	V
5	5	V	V
6	6	V	V

### 6.11.1 Estimated SAR

Estimated SAR for test separation distances  $\leq 50$  mm:

Antenna	Side	Band	Channel	Power-Tune up (dBm)	Frequency (GHz)	Distance (mm)	Power (mW)	Estimated SAR (mW/g)
								SAR <sup>1g</sup>
WLAN	2	IEEE 802.11b	1	10	2.412	11	10	0.188
	5	IEEE 802.11b	1	10	2.412	24	10	0.086

Estimated SAR for test separation distances  $> 50$  mm:

Antenna	Side	Band	Estimated SAR (mW/g)
			SAR <sup>1g</sup>
WLAN	4	IEEE 802.11b	0.4
WWAN	6	WCDMA Band II	0.4
		WCDMA Band V	0.4
		LTE Band 2	0.4
		LTE Band 4	0.4
		LTE Band 5	0.4
		LTE Band 17	0.4
WLAN		IEEE 802.11b	0.4



### 6.11.2 Sum of 1-g SAR of all simultaneously transmitting

When the sum of 1-g SAR of all simultaneously transmitting antennas in and operating mode and exposure condition combination is within the SAR limit, SAR test exclusion applies to that simultaneous transmission configuration.

Sum of 1-g SAR of summary as below:

Phantom Position		Spacing (mm)	ASSY	WWAN		WLAN		$\Sigma$ SAR <sup>1g</sup> (W/Kg)	Event
				Band	SAR <sup>1g</sup> (W/Kg)	Band	SAR <sup>1g</sup> (W/Kg)		
Flat	Side 1	10	N/A	WCDMA Band II	1.189	IEEE 802.11b	0.048	1.237	<1.6
		10	N/A	WCDMA Band V	0.780	IEEE 802.11b	0.048	0.828	<1.6
		10	N/A	LTE Band 2	1.422	IEEE 802.11b	0.048	1.470	<1.6
		10	N/A	LTE Band 4	1.442	IEEE 802.11b	0.048	1.490	<1.6
		10	N/A	LTE Band 5	0.726	IEEE 802.11b	0.048	0.774	<1.6
		10	N/A	LTE Band 17	1.148	IEEE 802.11b	0.048	1.196	<1.6
Flat	Side 2	10	N/A	WCDMA Band II	0.832	WLAN	*0.188	1.020	<1.6
		10	N/A	WCDMA Band V	0.696	WLAN	*0.188	0.884	<1.6
		10	N/A	LTE Band 2	0.998	WLAN	*0.188	1.186	<1.6
		10	N/A	LTE Band 4	0.743	WLAN	*0.188	0.931	<1.6
		10	N/A	LTE Band 5	0.661	WLAN	*0.188	0.849	<1.6
		10	N/A	LTE Band 17	1.103	WLAN	*0.188	1.291	<1.6
Flat	Side 3	10	N/A	WCDMA Band II	0.132	WLAN	0.032	0.164	<1.6
		10	N/A	WCDMA Band V	0.273	WLAN	0.032	0.305	<1.6
		10	N/A	LTE Band 2	0.140	WLAN	0.032	0.172	<1.6
		10	N/A	LTE Band 4	0.028	WLAN	0.032	0.060	<1.6
		10	N/A	LTE Band 5	0.269	WLAN	0.032	0.301	<1.6
		10	N/A	LTE Band 17	0.379	WLAN	0.032	0.411	<1.6
Flat	Side 4	10	N/A	WCDMA Band II	0.571	WLAN	**0.4	0.971	<1.6
		10	N/A	WCDMA Band V	0.270	WLAN	**0.4	0.670	<1.6
		10	N/A	LTE Band 2	0.654	WLAN	**0.4	1.054	<1.6
		10	N/A	LTE Band 4	0.536	WLAN	**0.4	0.936	<1.6
		10	N/A	LTE Band 5	0.264	WLAN	**0.4	0.664	<1.6
		10	N/A	LTE Band 17	0.593	WLAN	**0.4	0.993	<1.6

\*=Estimated SAR



Phantom Position		Spacing (mm)	ASSY	WWAN		WLAN		$\Sigma$ SAR <sup>1g</sup> (W/Kg)	Event
				Band	SAR <sup>1g</sup> (W/Kg)	Band	SAR <sup>1g</sup> (W/Kg)		
Flat	Side 5	10	N/A	WCDMA Band II	1.178	WLAN	*0.086	1.264	<1.6
		10	N/A	WCDMA Band V	0.151	WLAN	*0.086	0.237	<1.6
		10	N/A	LTE Band 2	1.316	WLAN	*0.086	1.402	<1.6
		10	N/A	LTE Band 4	1.194	WLAN	*0.086	1.280	<1.6
		10	N/A	LTE Band 5	0.153	WLAN	*0.086	0.239	<1.6
		10	N/A	LTE Band 17	0.135	WLAN	*0.086	0.221	<1.6
Flat	Side 6	10	N/A	WCDMA Band II	**0.4	WLAN	**0.4	0.800	<1.6
		10	N/A	WCDMA Band V	**0.4	WLAN	**0.4	0.800	<1.6
		10	N/A	LTE Band 2	**0.4	WLAN	**0.4	0.800	<1.6
		10	N/A	LTE Band 4	**0.4	WLAN	**0.4	0.800	<1.6
		10	N/A	LTE Band 5	**0.4	WLAN	**0.4	0.800	<1.6
		10	N/A	LTE Band 17	**0.4	WLAN	**0.4	0.800	<1.6

\*=Estimated SAR

### 6.11.3 SAR to peak location separation ratio (SPLSR)

When the sum of SAR is larger than the limit, SAR test exclusion is determined by the SAR to peak location separation ratio. The ratio is determined by  $(SAR1 + SAR2)^{1.5}/R_i$ , rounded to two decimal digits, and must be  $\leq 0.04$  for all antenna pairs in the configuration to qualify for 1-g SAR test exclusion.

**All of sum of SAR < 1.6 W/Kg, therefore SPLSR is not required.**



## 6.12 SAR test reduction according to KDB

General:

- The test data reported are the worst-case SAR value with the position set in a typical configuration. Test procedures used were according to FCC, Supplement C [June 2001], IEEE1528-2013 and IEEE Std. 1528a-2005.
- All modes of operation were investigated, and worst-case results are reported.
- Tissue parameters and temperatures are listed on the SAR plots.
- Batteries are fully charged for all readings.
- When the Channel's SAR 1g of maximum conducted power is > 0.8 mW/g, low, middle and high channel are supposed to be tested.

KDB 447498:

- The test data reported are the worst-case SAR value with the position set in a typical configuration. Test procedures used were according to IEEE1528-2013 and IEEE Std. 1528a-2005.

KDB 865664:

- Repeated measurement is not required when the original highest measured SAR is < 0.80 W/kg.
- When the original highest measured SAR is  $\geq 0.80$  W/kg, repeat that measurement once.
- Perform a second repeated measurement only if the ratio of largest to smallest SAR for the original and first repeated measurements is > 1.20 or when the original or repeated measurement is  $\geq 1.45$  W/kg.
- Perform a third repeated measurement only if the original, first or second repeated measurement is  $\geq 1.5$  W/kg and the ratio of largest to smallest SAR for the original, first and second repeated measurements is > 1.20.

KDB 941225:

- When HSDPA & (HSUPA / HSPA+ uplink with QPSK) power are not more than WCDMA 12.2K RMC 0.25dB and the SAR value of WCDMA BII/BV<1.2 mW/g, therefore HSDPA & HSUPA / HSPA+ Stand-alone SAR is not required.
- When the reported SAR is  $\leq 0.8$  W/kg, testing of the remaining RB offset configurations and required test channels is not required for 1 RB allocation, otherwise, SAR is required for the remaining required test channels and only for the RB offset configuration with the highest output power for that channel.
- For QPSK with 100% RB allocation, SAR is not required when the highest maximum output power for 100 % RB allocation is less than the highest maximum output power in 50% and 1 RB allocations and the highest reported SAR for 1 RB and 50% RB allocation in 5.2.1 and 5.2.2 are  $\leq 0.8$  W/kg. Otherwise, SAR is measured for the highest output power channel and if the reported SAR is > 1.45 W/kg, the remaining required test channels must also be tested.
- SAR is required only when the highest maximum output power for the configuration in the higher order modulation is >  $\frac{1}{2}$  dB higher than the same configuration in QPSK or when the reported SAR for the QPSK configuration is > 1.45 W/kg.
- For smaller channel bandwidth SAR when the highest maximum output power of a configuration requiring testing in the smaller channel bandwidth is >  $\frac{1}{2}$  dB higher than the equivalent channel configurations in the largest channel bandwidth configuration or the reported SAR of a configuration for the largest channel bandwidth is > 1.45 W/kg.
- SAR must be measured for all sides and surfaces with a transmitting antenna located within 25 mm from that surface or edge.

KDB 248227:

- If the conducted power of (802.11g and 802.11n) are higher than 802.11b 0.25dB,(802.11g and 802.11n) are supposed to be tested.

## 7. System Verification and Validation

### 7.1 Symmetric Dipoles for System Verification

Construction	Symmetrical dipole with 1/4 balun enables measurement of feed point impedance with NWA matched for use near flat phantoms filled with head simulating solutions Includes distance holder and tripod adaptor Calibration Calibrated SAR value for specified position and input power at the flat phantom in head simulating solutions.
Frequency	750, 835, 1750, 1900 and 2450 MHz
Return Loss	> 20 dB at specified verification position
Power Capability	> 100 W (f < 1GHz); > 40 W (f > 1GHz)
Options	Dipoles for other frequencies or solutions and other calibration conditions are available upon request
Dimensions	D750V2: dipole length 177 mm; overall height 300 mm D835V2: dipole length 161 mm; overall height 340 mm D1750V2: dipole length 75.2 mm; overall height 301.5 mm D1900V2: dipole length 67.7 mm; overall height 300 mm D2450V2: dipole length 51.5 mm; overall height 300 mm

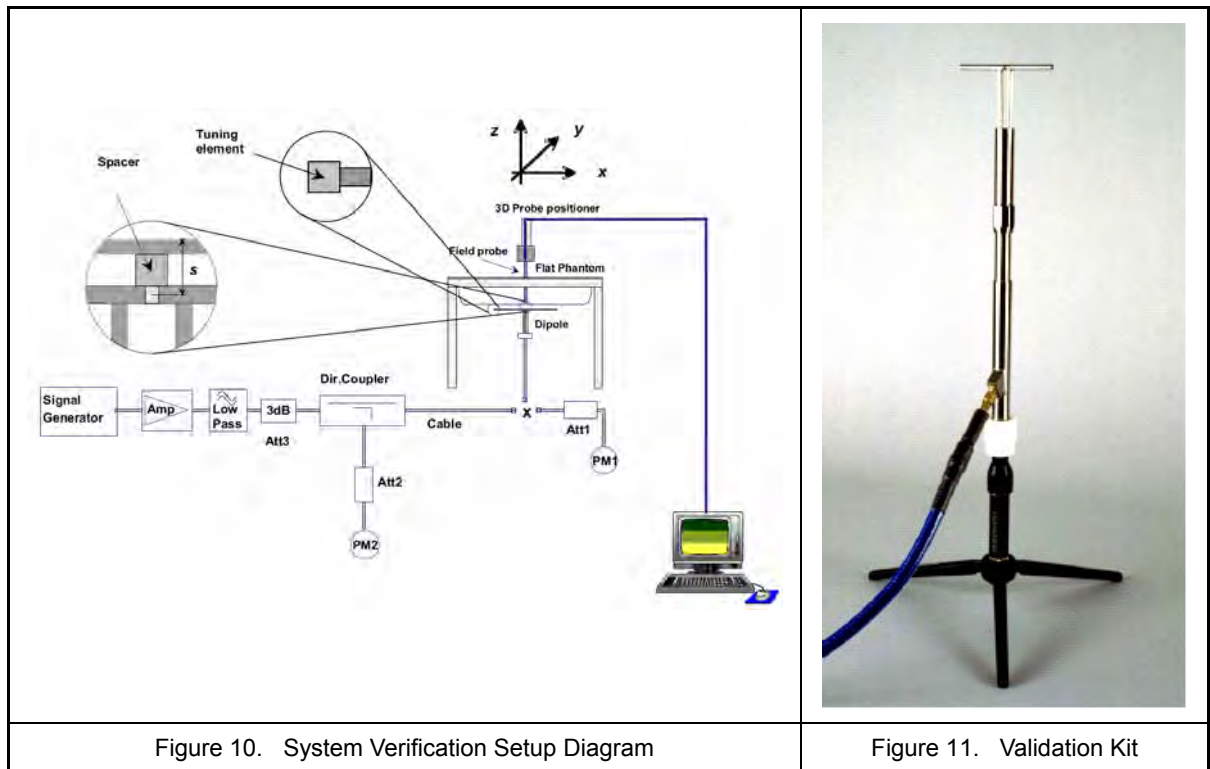

Figure 10. System Verification Setup Diagram

Figure 11. Validation Kit





## 7.2 Liquid Parameters

Liquid Verify								
Ambient Temperature : 22 ± 2 °C ; Relative Humidity : 40 -70%								
Liquid Type	Frequency	Temp (°C)	Parameters	Target Value	Measured Value	Deviation (%)	Limit (%)	Measured Date
750MHz (Body)	698MHz	22.0	$\epsilon_r$	55.73	54.00	-3.10%	± 5	2014/12/01
			$\sigma$	0.959	0.930	-3.02%	± 5	
	730MHz	22.0	$\epsilon_r$	55.61	53.46	-3.87%	± 5	
			$\sigma$	0.962	0.976	1.46%	± 5	
	750MHz	22.0	$\epsilon_r$	55.53	53.56	-3.55%	± 5	
			$\sigma$	0.963	1.010	4.88%	± 5	
835MHz (Body)	820MHz	22.0	$\epsilon_r$	55.26	55.33	0.13%	± 5	2014/11/28
			$\sigma$	0.969	0.973	0.41%	± 5	
	835MHz	22.0	$\epsilon_r$	55.20	55.29	0.16%	± 5	
			$\sigma$	0.970	0.990	2.06%	± 5	
	850MHz	22.0	$\epsilon_r$	55.15	55.28	0.24%	± 5	
			$\sigma$	0.988	1.011	2.33%	± 5	
1750MHz (Body)	1700MHz	22.0	$\epsilon_r$	53.56	54.40	1.57%	± 5	2014/11/27
			$\sigma$	1.457	1.492	2.40%	± 5	
	1750MHz	22.0	$\epsilon_r$	53.43	54.29	1.61%	± 5	
			$\sigma$	1.488	1.532	2.96%	± 5	
	1760MHz	22.0	$\epsilon_r$	53.41	54.29	1.65%	± 5	
			$\sigma$	1.495	1.540	3.01%	± 5	
1750MHz (Body)	1700MHz	22.0	$\epsilon_r$	53.56	54.40	1.57%	± 5	2014/12/16
			$\sigma$	1.457	1.492	2.40%	± 5	
	1750MHz	22.0	$\epsilon_r$	53.43	54.29	1.61%	± 5	
			$\sigma$	1.488	1.532	2.96%	± 5	
	1760MHz	22.0	$\epsilon_r$	53.41	54.29	1.65%	± 5	
			$\sigma$	1.495	1.540	3.01%	± 5	
1900MHz (Body)	1850MHz	22.0	$\epsilon_r$	53.30	51.82	-2.78%	± 5	2014/11/26
			$\sigma$	1.520	1.463	-3.75%	± 5	
	1900MHz	22.0	$\epsilon_r$	53.30	51.63	-3.13%	± 5	
			$\sigma$	1.520	1.511	-0.59%	± 5	
	1950MHz	22.0	$\epsilon_r$	53.30	51.70	-3.00%	± 5	
			$\sigma$	1.520	1.570	3.29%	± 5	

Table 4. Measured Tissue dielectric parameters for body phantoms -1



Liquid Verify								
Ambient Temperature : 22 ± 2 °C ; Relative Humidity : 40 -70%								
Liquid Type	Frequency	Temp (°C)	Parameters	Target Value	Measured Value	Deviation (%)	Limit (%)	Measured Date
1900MHz (Body)	1850MHz	22.0	$\epsilon_r$	53.30	51.82	-2.78%	± 5	2014/11/27
			$\sigma$	1.520	1.463	-3.75%	± 5	
	1900MHz	22.0	$\epsilon_r$	53.30	51.63	-3.13%	± 5	
			$\sigma$	1.520	1.511	-0.59%	± 5	
	1950MHz	22.0	$\epsilon_r$	53.30	51.70	-3.00%	± 5	
			$\sigma$	1.520	1.570	3.29%	± 5	
1900MHz (Body)	1850MHz	22.0	$\epsilon_r$	53.30	51.82	-2.78%	± 5	2014/12/16
			$\sigma$	1.520	1.463	-3.75%	± 5	
	1900MHz	22.0	$\epsilon_r$	53.30	51.63	-3.13%	± 5	
			$\sigma$	1.520	1.511	-0.59%	± 5	
	1950MHz	22.0	$\epsilon_r$	53.30	51.70	-3.00%	± 5	
			$\sigma$	1.520	1.570	3.29%	± 5	
1900MHz (Body)	1850MHz	22.0	$\epsilon_r$	53.30	51.82	-2.78%	± 5	2015/01/16
			$\sigma$	1.520	1.463	-3.75%	± 5	
	1900MHz	22.0	$\epsilon_r$	53.30	51.63	-3.13%	± 5	
			$\sigma$	1.520	1.511	-0.59%	± 5	
	1950MHz	22.0	$\epsilon_r$	53.30	51.70	-3.00%	± 5	
			$\sigma$	1.520	1.570	3.29%	± 5	
2450MHz (Body)	2400MHz	22.0	$\epsilon_r$	52.77	54.02	2.37%	± 5	2014/12/05
			$\sigma$	1.902	1.881	-1.10%	± 5	
	2450MHz	22.0	$\epsilon_r$	52.70	54.46	3.34%	± 5	
			$\sigma$	1.950	1.980	1.54%	± 5	
	2500MHz	22.0	$\epsilon_r$	52.64	53.61	1.84%	± 5	
			$\sigma$	2.021	2.016	-0.25%	± 5	

Table 5. Measured Tissue dielectric parameters for body phantoms -2



### 7.3 Verification Summary

Prior to the assessment, the system validation kit was used to test whether the system was operating within its specifications of  $\pm 7\%$ . The verification was performed at 750, 835, 1750, 1900 and 2450MHz.

Mixture Type	Frequency (MHz)	Power	SAR <sub>1g</sub> (W/Kg)	SAR <sub>10g</sub> (W/Kg)	Drift (dB)	Difference percentage		Probe Model / Serial No.	Dipole Model / Serial No.	1W Target		Date
						1g	10g			SAR <sub>1g</sub> (W/Kg)	SAR <sub>10g</sub> (W/Kg)	
Body	750	250 mW	2.21	1.46	-0.07	2.20%	3.20%	EX3DV4 SN:3977	D750V3 SN:1004	8.65	5.66	Dec. 01, 2014
		Normalize to 1 Watt	8.84	5.84								
Body	835	250 mW	2.43	1.61	0.1	2.30%	2.70%	EX3DV4 SN:3977	D835V2 SN:4d082	9.50	6.27	Nov. 28, 2014
		Normalize to 1 Watt	9.72	6.44								
Body	1750	250 mW	9.38	4.91	0.06	-1.00%	-3.70%	EX3DV4 SN:3977	D1750V2 SN:1023	37.90	20.40	Nov. 27, 2014
		Normalize to 1 Watt	37.52	19.64								
Body	1750	250 mW	9.3	4.86	0.05	-1.80%	-4.70%	EX3DV4 SN:3977	D1750V2 SN:1023	37.90	20.40	Dec. 16, 2014
		Normalize to 1 Watt	37.20	19.44								
Body	1900	250 mW	10.1	5.26	0	0.00%	-2.10%	EX3DV4 SN:3977	D1900V2 SN:5d111	40.40	21.50	Nov. 26, 2014
		Normalize to 1 Watt	40.40	21.04								
Body	1900	250 mW	9.97	5.24	-0.1	-1.30%	-2.50%	EX3DV4 SN:3977	D1900V2 SN:5d111	40.40	21.50	Nov. 27, 2014
		Normalize to 1 Watt	39.88	20.96								
Body	1900	250 mW	10.2	5.29	0.05	1.00%	-1.60%	EX3DV4 SN:3977	D1900V2 SN:5d111	40.40	21.50	Dec. 16, 2014
		Normalize to 1 Watt	40.80	21.16								
Body	1900	250 mW	10.10	5.20	0.04	0.00%	-3.30%	EX3DV4 SN:3977	D1900V2 SN:5d111	40.40	21.50	Jan. 16, 2015
		Normalize to 1 Watt	40.40	20.80								
Body	2450	250 mW	13	6	0.01	3.40%	2.10%	EX3DV4 SN:3977	D2450V2 SN:712	50.30	23.50	Dec. 05, 2014
		Normalize to 1 Watt	52.00	24.00								



## 7.4 Validation Summary

Per FCC KDB 865664 D02v01r01, SAR system validation status should be documented to confirm measurement accuracy. The SAR systems (including SAR probes, system components and software versions) used for this device were validated against its performance specifications prior to the SAR measurements. Reference dipoles were used with the required tissue- equivalent media for system validation, according to the procedures outlined in IEEE 1528-2013 and FCC KDB 865664 D01v01r03. Since SAR probe calibrations are frequency dependent, each probe calibration point was validated at a frequency within the valid frequency range of the probe calibration point, using the system that normally operates with the probe for routine SAR measurements and according to the required tissue-equivalent media.

A tabulated summary of the system validation status including the validation date(s), measurement frequencies, SAR probes and tissue dielectric parameters as below.

Probe Type Model / Serial No.	Prob Cal. Point (MHz)	Head / Body	Cond.	Perm.	CW Validation			Mod. Validation			Date
			$\epsilon_r$	$\sigma$	Sensitivity	Probe	Probe	Mod. Type	Duty Factor	PAR	
						Linearity	Isotropy				
EX3DV4 SN:3977	750	Body	53.56	1.010	Pass	Pass	Pass	GMSK	Pass	N/A	Dec. 01, 2014
EX3DV4 SN:3977	835	Body	55.29	0.990	Pass	Pass	Pass	GMSK	Pass	N/A	Nov. 28, 2014
EX3DV4 SN:3977	1750	Body	54.29	1.532	Pass	Pass	Pass	GMSK	Pass	N/A	Nov. 27, 2014
EX3DV4 SN:3977	1750	Body	54.29	1.532	Pass	Pass	Pass	GMSK	Pass	N/A	Dec. 16, 2014
EX3DV4 SN:3977	1900	Body	51.63	1.511	Pass	Pass	Pass	GMSK	Pass	N/A	Nov. 26, 2014
EX3DV4 SN:3977	1900	Body	51.63	1.511	Pass	Pass	Pass	GMSK	Pass	N/A	Nov. 27, 2014
EX3DV4 SN:3977	1900	Body	51.63	1.511	Pass	Pass	Pass	GMSK	Pass	N/A	Dec. 16, 2014
EX3DV4 SN:3977	1900	Body	51.63	1.511	Pass	Pass	Pass	GMSK	Pass	N/A	Jan. 16, 2015
EX3DV4 SN:3977	2450	Body	54.46	1.980	Pass	Pass	Pass	OFDM	N/A	Pass	Dec. 05, 2014



## 8. Test Equipment List

Manufacturer	Name of Equipment	Type/Model	Serial Number	Calibration	
				Last Cal.	Due Date
SPEAG	750MHz System Validation Kit	D750V2	1004	Jan. 28, 2014	Jan. 28, 2015
SPEAG	835MHz System Validation Kit	D835V2	4d082	Jul. 23, 2014	Jul. 23, 2015
SPEAG	1750MHz System Validation Kit	D1750V2	1023	Jun. 17, 2014	Jun. 17, 2015
SPEAG	1900MHz System Validation Kit	D1900V2	5d111	Jul. 23, 2014	Jul. 23, 2015
SPEAG	2450MHz System Validation Kit	D2450V2	712	Mar. 04, 2014	Mar. 04, 2015
SPEAG	Dosimetric E-Field Probe	EX3DV4	3977	Feb. 17, 2014	Feb. 17, 2015
SPEAG	Data Acquisition Electronics	DAE4	712	Mar. 04, 2014	Mar. 04, 2015
SPEAG	Device Holder	N/A	N/A	NCR	
SPEAG	Measurement Server	SE UMS 011 AA	1025	NCR	
SPEAG	Phantom	SAM V4.0	TP-1133	NCR	
SPEAG	Robot	Staubli TX90XL	F07/564ZA1/C/01	NCR	
SPEAG	Software	DASY52 V52.8 (7)	N/A	NCR	
SPEAG	Software	SEMCAD X V14.6.10 (7164)	N/A	NCR	
Agilent	Dielectric Probe Kit	85070C	US99360094	NCR	
Agilent	ENA Series Network Analyzer	E5071B	MY42404655	Apr. 10, 2014	Apr. 10, 2015
R&S	Power Sensor	NRP-Z22	100179	May 20, 2014	May 20, 2015
Agilent	MXF-G-B RF Vector Signal Generator	N5182B	MY53050382	May 30, 2014	May 30, 2015
Agilent	Dual Directional Coupler	778D	50334	NCR	
Mini-Circuits	Power Amplifier	ZHL-42W-SMA	D111103#5	NCR	
Mini-Circuits	Power Amplifier	ZVE-8G-SMA	D042005 671800514	NCR	
Aisi	Attenuator	IEAT 3dB	N/A	NCR	

Table 6. Test Equipment List



## 9. **Measurement Uncertainty**

Measurement uncertainties in SAR measurements are difficult to quantify due to several variables including biological, physiological, and environmental. However, we estimate the measurement uncertainties in SAR to be less than  $\pm 19.62\%$  [ 8 ] . The frequency range of the measurement uncertainty is 750 ~ 5800MHz  $\pm 10.1\%$

According to Std. C95.3 [ 9 ] , the overall uncertainties are difficult to assess and will vary with the type of meter and usage situation. However, accuracy's of  $\pm 1$  to 3 dB can be expected in practice, with greater uncertainties in near-field situations and at higher frequencies (shorter wavelengths), or areas where large reflecting objects are present. Under optimum measurement conditions, SAR measurement uncertainties of at least  $\pm 2$ dB can be expected.



Item	Uncertainty Component	Uncertainty Value	Prob. Dist	Div.	$c_i$ (1g)	$c_i$ (10g)	Std. Unc. (1-g)	Std. Unc. (10-g)	$V_i$ or $V_{eff}$
Measurement System									
u1	Probe Calibration ( $k=1$ )	$\pm 5.05\%$	Normal	1	1	1	$\pm 5.05\%$	$\pm 5.05\%$	$\infty$
u2	Probe Isotropy	$\pm 7.6\%$	Rectangular	$\sqrt{3}$	0.7	0.7	$\pm 3.1\%$	$\pm 3.1\%$	$\infty$
u3	Boundary Effect	$\pm 1.0\%$	Rectangular	$\sqrt{3}$	1	1	$\pm 0.6\%$	$\pm 0.6\%$	$\infty$
u4	Linearity	$\pm 4.7\%$	Rectangular	$\sqrt{3}$	1	1	$\pm 2.7\%$	$\pm 2.7\%$	$\infty$
u5	System Detection Limit	$\pm 1.0\%$	Rectangular	$\sqrt{3}$	1	1	$\pm 0.58\%$	$\pm 0.58\%$	$\infty$
u6	Readout Electronics	$\pm 0.3\%$	Normal	1	1	1	$\pm 0.3\%$	$\pm 0.3\%$	$\infty$
u7	Response Time	$\pm 0.8\%$	Rectangular	$\sqrt{3}$	1	1	$\pm 0.5\%$	$\pm 0.5\%$	$\infty$
u8	Integration Time	$\pm 2.6\%$	Rectangular	$\sqrt{3}$	1	1	$\pm 1.5\%$	$\pm 1.5\%$	$\infty$
u9	RF Ambient Conditions	$\pm 0\%$	Rectangular	$\sqrt{3}$	1	1	$\pm 0\%$	$\pm 0\%$	$\infty$
u10	RF Ambient Reflections	$\pm 0\%$	Rectangular	$\sqrt{3}$	1	1	$\pm 0\%$	$\pm 0\%$	$\infty$
u11	Probe Positioner Mechanical Tolerance	$\pm 0.4\%$	Rectangular	$\sqrt{3}$	1	1	$\pm 0.2\%$	$\pm 0.2\%$	$\infty$
u12	Probe Positioning with respect to Phantom Shell	$\pm 2.9\%$	Rectangular	$\sqrt{3}$	1	1	$\pm 1.7\%$	$\pm 1.7\%$	$\infty$
u13	Extrapolation, interpolation and integration Algorithms for Max. SAR Evaluation	$\pm 1.0\%$	Rectangular	$\sqrt{3}$	1	1	$\pm 0.6\%$	$\pm 0.6\%$	$\infty$
Test sample Related									
u14	Test sample Positioning	$\pm 3.6\%$	Normal	1	1	1	$\pm 3.6\%$	$\pm 3.6\%$	89
u15	Device Holder Uncertainty	$\pm 3.5\%$	Normal	1	1	1	$\pm 3.5\%$	$\pm 3.5\%$	5
u16	Output Power Variation - SAR drift measurement	$\pm 5.0\%$	Rectangular	$\sqrt{3}$	1	1	$\pm 2.9\%$	$\pm 2.9\%$	$\infty$
Phantom and Tissue Parameters									
u17	Phantom Uncertainty ( shape and thickness tolerances)	$\pm 4.0\%$	Rectangular	$\sqrt{3}$	1	1	$\pm 2.3\%$	$\pm 2.3\%$	$\infty$
u18	Liquid Conductivity - deviation from target values	$\pm 5.0\%$	Rectangular	$\sqrt{3}$	0.64	0.43	$\pm 1.8\%$	$\pm 1.2\%$	$\infty$
u19	Liquid Conductivity - measurement uncertainty	$\pm 1.93\%$	Normal	1	0.64	0.43	$\pm 1.24\%$	$\pm 0.83\%$	69
u20	Liquid Permittivity - deviation from target values	$\pm 5.0\%$	Rectangular	$\sqrt{3}$	0.6	0.49	$\pm 1.7\%$	$\pm 1.4\%$	$\infty$
u21	Liquid Permittivity - measurement uncertainty	$\pm 1.4\%$	Normal	1	0.6	0.49	$\pm 0.84\%$	$\pm 1.69\%$	69
Combined standard uncertainty			RSS				$\pm 9.81\%$	$\pm 9.62\%$	313
Expanded uncertainty (95% CONFIDENCE LEVEL )			$k=2$				$\pm 19.62\%$	$\pm 19.24\%$	

Table 7. Uncertainty Budget of DASY



## 10. Measurement Procedure

The measurement procedures are as follows:

1. For WLAN function, engineering testing software installed on Notebook can provide continuous transmitting signal.
2. Measure output power through RF cable and power meter
3. Set scan area, grid size and other setting on the DASY software
4. Find out the largest SAR result on these testing positions of each band
5. Measure SAR results for other channels in worst SAR testing position if the SAR of highest power channel is larger than 0.8 W/kg

According to the test standard, the recommended procedure for assessing the peak spatial-average SAR value consists of the following steps:

1. Power reference measurement
2. Area scan
3. Zoom scan
4. Power drift measurement

### 10.1 Spatial Peak SAR Evaluation

The procedure for spatial peak SAR evaluation has been implemented according to the test standard. It can be conducted for 1g and 10g, as well as for user-specific masses. The DASY software includes all numerical procedures necessary to evaluate the spatial peak SAR value.

The base for the evaluation is a "cube" measurement. The measured volume must include the 1g and 10g cubes with the highest averaged SAR values. For that purpose, the center of the measured volume is aligned to the interpolated peak SAR value of a previously performed area scan.

The entire evaluation of the spatial peak values is performed within the post-processing engine (SEMCAD). The system always gives the maximum values for the 1g and 10g cubes. The algorithm to find the cube with highest averaged SAR is divided into the following stages

1. Extraction of the measured data (grid and values) from the Zoom Scan
2. Calculation of the SAR value at every measurement point based on all stored data (A/D values and measurement parameters)
3. Generation of a high-resolution mesh within the measured volume
4. Interpolation of all measured values from the measurement grid to the high-resolution grid
5. Extrapolation of the entire 3-D field distribution to the phantom surface over the distance from sensor to surface
6. Calculation of the averaged SAR within masses of 1g and 10g





## 10.2 Area & Zoom Scan Procedures

First Area Scan is used to locate the approximate location(s) of the local peak SAR value(s). The measurement grid within an Area Scan is defined by the grid extent, grid step size and grid offset. Next, in order to determine the EM field distribution in a three-dimensional spatial extension, Zoom Scan is required. The Zoom Scan measures points and step size follow as below. The Zoom Scan is performed around the highest E-field value to determine the averaged SAR-distribution over 10 g.

Grid Type	Frequency		Step size (mm)			X*Y*Z (Point)	Cube size			Step size		
			X	Y	Z		X	Y	Z	X	Y	Z
uniform grid	≤ 3GHz	≤ 2GHz	≤ 8	≤ 8	≤ 5	5*5*7	32	32	30	8	8	5
		2G - 3G	≤ 5	≤ 5	≤ 5	7*7*7	30	30	30	5	5	5
	3 - 6GHz	3 - 4GHz	≤ 5	≤ 5	≤ 4	7*7*8	30	30	28	5	5	4
		4 - 5GHz	≤ 4	≤ 4	≤ 3	8*8*10	28	28	27	4	4	3
		5 - 6GHz	≤ 4	≤ 4	≤ 2	8*8*12	28	28	22	4	4	2

(Our measure settings are refer KDB Publication 865664 D01v01r03)

## 10.3 Volume Scan Procedures

The volume scan is used for assess overlapping SAR distributions for antennas transmitting in different frequency bands. It is equivalent to an oversized zoom scan used in standalone measurements. The measurement volume will be used to enclose all the simultaneous transmitting antennas. For antennas transmitting simultaneously in different frequency bands, the volume scan is measured separately in each frequency band. In order to sum correctly to compute the 1g aggregate SAR, the DUT remain in the same test position for all measurements and all volume scan use the same spatial resolution and grid spacing. When all volume scan were completed, the software, SEMCAD postprocessor can combine and subsequently superpose these measurement data to calculating the multiband SAR.

## 10.4 SAR Averaged Methods

In DASYS, the interpolation and extrapolation are both based on the modified Quadratic Shepard's method. The interpolation scheme combines a least-square fitted function method and a weighted average method which are the two basic types of computational interpolation and approximation. Extrapolation routines are used to obtain SAR values between the lowest measurement points and the inner phantom surface. The extrapolation distance is determined by the surface detection distance and the probe sensor offset. The uncertainty increases with the extrapolation distance. To keep the uncertainty within 1% for the 1 g and 10 g cubes, the extrapolation distance should not be larger than 5 mm.

## 10.5 Power Drift Monitoring

All SAR testing is under the DUT install full charged battery and transmit maximum output power. In DASYS measurement software, the power reference measurement and power drift measurement procedures are used for monitoring the power drift of DUT during SAR test. Both these procedures measure the field at a specified reference position before and after the SAR testing. The software will calculate the field difference in dB. If the power drift more than 5%, the SAR will be retested.



## 11. SAR Test Results Summary

### 11.1 Head Measurement SAR

Evaluated head SAR is not available.

### 11.2 Body Measurement SAR

Evaluated body SAR refers to Hot-spot mode measurement results.

### 11.3 Hot-spot mode Measurement SAR

Index.	Position	Band	Ch.	Data Rate or Sub-Test	Side to Phantom	Spacing (mm)	SAR <sub>1g</sub> (W/Kg)	Power Drift	Burst Avg Power	Max tune-up	Reported SAR <sub>1g</sub> (W/Kg)
#25	Flat	WCDMA Band II	9262	RMC12.2K	1	10	1.130	-0.02	22.78	23	1.189
#31	Flat		9262	RMC12.2K	5	10	1.120	0.03	22.78	23	1.178
#101	Flat		9262	RMC12.2K	2	10	0.742	-0.04	22.78	23	0.781
#24	Flat		9400	RMC12.2K	1	10	1.110	0.01	22.79	23	1.165
#27	Flat		9400	RMC12.2K	2	10	0.772	-0.07	22.79	23	0.810
#28	Flat		9400	RMC12.2K	3	10	0.126	0.03	22.79	23	0.132
#29	Flat		9400	RMC12.2K	4	10	0.544	-0.02	22.79	23	0.571
#30	Flat		9400	RMC12.2K	5	10	1.080	0.00	22.79	23	1.134
#26	Flat		9538	RMC12.2K	1	10	1.030	0.04	22.53	23	1.148
#32	Flat		9538	RMC12.2K	5	10	0.976	-0.03	22.53	23	1.088
#102	Flat		9538	RMC12.2K	2	10	0.747	-0.02	22.53	23	0.832
#56	Flat	WCDMA Band V	4233	RMC12.2K	1	10	0.658	-0.03	23.26	24	0.780
#57	Flat		4233	RMC12.2K	2	10	0.587	-0.03	23.26	24	0.696
#58	Flat		4233	RMC12.2K	3	10	0.230	-0.06	23.26	24	0.273
#59	Flat		4233	RMC12.2K	4	10	0.228	-0.05	23.26	24	0.270
#60	Flat		4233	RMC12.2K	5	10	0.127	-0.07	23.26	24	0.151

- Note: 1. According KDB 447498 D01 V05r02 section 4.1.4, the "Reported" explanation as below:  
 "When SAR or MPE is measured at or scaled to the maximum tune-up tolerance limit, the results are referred to as reported."
2. If the Channel's Reported SAR<sub>1g</sub> of maximum conducted power is > 0.8 W/Kg, low, middle and high channel are supposed to be tested.(3G/LTE/WLAN)
3. HSDPA & (HSUPA HSPA+\_QPSK UP Link) power are not more than WCDMA BII/BV 0.25dB and the SAR value of WCDMA BII/BV<1.2 W/kg ,therefore HSDPA & HSUPA Stand-alone SAR is not required.



Index.	Position	Band	Ch.	BW (MHz)	Modulation	RB		Side to Phantom	Spacing (mm)	SAR <sub>1g</sub> (W/Kg)	Power Drift	Burst Avg Power	Max tune-up	Reported SAR <sub>1g</sub>
						Size	Offset							
#1	Flat	LTE Band 2	18700	20	QPSK	1	99	1	10	1.210	0.07	22.80	23.5	1.422
#8	Flat		18700	20	QPSK	1	99	2	10	0.802	-0.08	22.80	23.5	0.942
#14	Flat		18700	20	QPSK	1	99	3	10	0.119	-0.01	22.80	23.5	0.140
#15	Flat		18700	20	QPSK	1	99	4	10	0.557	0.06	22.80	23.5	0.654
#18	Flat		18700	20	QPSK	1	99	5	10	1.060	-0.05	22.80	23.5	1.245
#2	Flat		18900	20	QPSK	1	0	1	10	1.150	0.18	22.72	23.5	1.376
#9	Flat		18900	20	QPSK	1	0	2	10	0.834	-0.02	22.72	23.5	0.998
#19	Flat		18900	20	QPSK	1	0	5	10	1.100	0.08	22.72	23.5	1.316
#3	Flat		19100	20	QPSK	1	0	1	10	0.977	0.04	22.41	23.5	1.256
#10	Flat		19100	20	QPSK	1	0	2	10	0.703	0.01	22.41	23.5	0.904
#20	Flat		19100	20	QPSK	1	0	5	10	0.908	0.09	22.41	23.5	1.167
#5	Flat		18700	20	QPSK	50	50	1	10	0.854	0.06	21.25	22.0	1.015
#92	Flat		18700	20	QPSK	50	50	5	10	0.822	0.02	21.25	22.0	0.977
#4	Flat		18900	20	QPSK	50	50	1	10	0.788	-0.04	21.55	22.0	0.874
#11	Flat		18900	20	QPSK	50	50	2	10	0.549	0.03	21.55	22.0	0.609
#13	Flat		18900	20	QPSK	50	50	3	10	0.086	-0.04	21.55	22.0	0.095
#16	Flat		18900	20	QPSK	50	50	4	10	0.404	0.05	21.55	22.0	0.448
#17	Flat		18900	20	QPSK	50	50	5	10	0.722	0.05	21.55	22.0	0.801
#6	Flat		19100	20	QPSK	50	0	1	10	0.703	-0.03	21.17	22.0	0.851
#93	Flat		19100	20	QPSK	50	0	5	10	0.660	-0.01	21.17	22.0	0.799
#7	Flat		18900	20	QPSK	100	0	1	10	0.821	0.06	21.43	21.5	0.834
#12	Flat	18900	20	QPSK	100	0	2	10	0.594	-0.03	21.43	21.5	0.604	
#21	Flat	18900	20	QPSK	100	0	5	10	0.739	0.06	21.43	21.5	0.751	

- Note: 1. According KDB 447498 D01 V05r02 section 4.1.4, the "Reported" explanation as below:  
 "When SAR or MPE is measured at or scaled to the maximum tune-up tolerance limit, the results are referred to as reported."
2. If the Channel's Reported SAR<sub>1g</sub> of maximum conducted power is > 0.8 W/Kg, low, middle and high channel are supposed to be tested.(3G/LTE/WLAN)
  3. When the highest reported SAR for 1 RB and 50% RB allocation are > 0.8 W/kg,SAR is measured for the highest output power channel in 100%RB.
  4. Start with the largest channel bandwidth and measure SAR for QPSK with 1 RB allocation, using the RB offset and required test channel combination with the highest maximum output power for RB offsets at the upper edge,middle and lower edge of each required test channel.



Index.	Position	Band	Ch.	BW (MHz)	Modulation	RB		Side to Phantom	Spacing (mm)	SAR <sub>1g</sub> (W/Kg)	Power Drift	Burst Avg Power	Max tune-up	Reported SAR <sub>1g</sub>
						Size	Offset							
#34	Flat	LTE Band 4	20050	20	QPSK	1	49	1	10	1.210	0.04	22.37	23.0	1.399
#42	Flat		20050	20	QPSK	1	49	2	10	0.643	0.03	22.37	23.0	0.743
#43	Flat		20050	20	QPSK	1	49	3	10	0.024	-0.01	22.37	23.0	0.028
#46	Flat		20050	20	QPSK	1	49	4	10	0.464	0.08	22.37	23.0	0.536
#47	Flat		20050	20	QPSK	1	49	5	10	1.010	0.07	22.37	23.0	1.168
#35	Flat		20175	20	QPSK	1	0	1	10	1.240	-0.02	22.36	23.0	1.437
#48	Flat		20175	20	QPSK	1	0	5	10	1.030	0.05	22.36	23.0	1.194
#36	Flat		20300	20	QPSK	1	0	1	10	1.230	-0.03	22.31	23.0	1.442
#49	Flat		20300	20	QPSK	1	0	5	10	1.000	0.05	22.31	23.0	1.172
#38	Flat		20050	20	QPSK	50	50	1	10	0.949	0.05	21.32	21.5	0.989
#51	Flat		20050	20	QPSK	50	50	5	10	0.766	0.05	21.32	21.5	0.798
#37	Flat		20175	20	QPSK	50	0	1	10	0.941	-0.10	21.36	21.5	0.972
#41	Flat		20175	20	QPSK	50	0	2	10	0.491	-0.04	21.36	21.5	0.507
#44	Flat		20175	20	QPSK	50	0	3	10	0.023	-0.06	21.36	21.5	0.024
#45	Flat		20175	20	QPSK	50	0	4	10	0.341	0.07	21.36	21.5	0.352
#50	Flat		20175	20	QPSK	50	0	5	10	0.771	0.07	21.36	21.5	0.796
#39	Flat		20300	20	QPSK	50	0	1	10	0.945	0.08	21.34	21.5	0.980
#52	Flat		20300	20	QPSK	50	0	5	10	0.764	0.15	21.34	21.5	0.793
#40	Flat		20175	20	QPSK	100	0	1	10	0.908	0.04	21.33	21.5	0.944
#53	Flat		20175	20	QPSK	100	0	5	10	0.770	0.03	21.33	21.5	0.801
#61	Flat	LTE Band 5	20600	10	QPSK	1	0	1	10	0.607	0.04	23.22	24.0	0.726
#62	Flat		20600	10	QPSK	1	0	2	10	0.552	0.08	23.22	24.0	0.661
#66	Flat		20600	10	QPSK	1	0	3	10	0.225	-0.14	23.22	24.0	0.269
#67	Flat		20600	10	QPSK	1	0	4	10	0.221	0.03	23.22	24.0	0.264
#70	Flat		20600	10	QPSK	1	0	5	10	0.128	-0.17	23.22	24.0	0.153

- Note: 1. According KDB 447498 D01 V05r02 section 4.1.4, the "Reported" explanation as below:  
 "When SAR or MPE is measured at or scaled to the maximum tune-up tolerance limit, the results are referred to as reported."
2. If the Channel's Reported SAR 1g of maximum conducted power is > 0.8 W/Kg, low, middle and high channel are supposed to be tested.(3G/LTE/WLAN)
  3. When the highest reported SAR for 1 RB and 50% RB allocation are > 0.8 W/kg,SAR is measured for the highest output power channel in 100%RB.
  4. Start with the largest channel bandwidth and measure SAR for QPSK with 1 RB allocation, using the RB offset and required test channel combination with the highest maximum output power for RB offsets at the upper edge,middle and lower edge of each required test channel.



Index.	Position	Band	Ch.	BW (MHz)	Modulation	RB		Side to Phantom	Spacing (mm)	SAR <sub>1g</sub> (W/Kg)	Power Drift	Burst Avg Power	Max tune-up	Reported SAR <sub>1g</sub>
						Size	Offset							
#64	Flat	LTE Band 5	20600	10	QPSK	25	0	1	10	0.511	-0.04	22.13	22.5	0.556
#63	Flat		20600	10	QPSK	25	0	2	10	0.444	0.01	22.13	22.5	0.483
#65	Flat		20600	10	QPSK	25	0	3	10	0.179	-0.02	22.13	22.5	0.195
#68	Flat		20600	10	QPSK	25	0	4	10	0.176	0.01	22.13	22.5	0.192
#69	Flat		20600	10	QPSK	25	0	5	10	0.101	-0.12	22.13	22.5	0.110
#71	Flat	LTE Band 17	23780	10	QPSK	1	0	1	10	1.130	-0.06	23.93	24.0	1.148
#78	Flat		23780	10	QPSK	1	0	2	10	1.070	-0.03	23.93	24.0	1.087
#86	Flat		23780	10	QPSK	1	0	3	10	0.373	-0.04	23.93	24.0	0.379
#87	Flat		23780	10	QPSK	1	0	4	10	0.584	0.02	23.93	24.0	0.593
#90	Flat		23780	10	QPSK	1	0	5	10	0.133	0.10	23.93	24.0	0.135
#72	Flat		23790	10	QPSK	1	0	1	10	1.110	-0.07	23.87	24.0	1.144
#79	Flat		23790	10	QPSK	1	0	2	10	1.070	-0.06	23.87	24.0	1.103
#73	Flat		23800	10	QPSK	1	0	1	10	1.070	-0.05	23.78	24.0	1.126
#80	Flat		23800	10	QPSK	1	0	2	10	1.030	-0.01	23.78	24.0	1.084
#75	Flat		23780	10	QPSK	25	12	1	10	0.853	-0.05	22.76	23.0	0.901
#82	Flat		23780	10	QPSK	25	12	2	10	0.809	0.02	22.76	23.0	0.855
#74	Flat		23790	10	QPSK	25	12	1	10	0.851	-0.09	22.79	23.0	0.893
#81	Flat		23790	10	QPSK	25	12	2	10	0.819	0.05	22.79	23.0	0.860
#85	Flat		23790	10	QPSK	25	12	3	10	0.288	0.03	22.79	23.0	0.302
#88	Flat		23790	10	QPSK	25	12	4	10	0.452	0.00	22.79	23.0	0.474
#89	Flat		23790	10	QPSK	25	12	5	10	0.102	0.06	22.79	23.0	0.107
#76	Flat		23800	10	QPSK	25	12	1	10	0.853	0.02	22.73	23.0	0.908
#83	Flat		23800	10	QPSK	25	12	2	10	0.823	0.02	22.73	23.0	0.876
#77	Flat		23790	10	QPSK	50	0	1	10	0.818	-0.13	22.65	23.0	0.887
#84	Flat		23790	10	QPSK	50	0	2	10	0.790	-0.07	22.65	23.0	0.856

- Note: 1. According KDB 447498 D01 V05r02 section 4.1.4, the "Reported" explanation as below:  
 "When SAR or MPE is measured at or scaled to the maximum tune-up tolerance limit, the results are referred to as reported."
2. If the Channel's Reported SAR 1g of maximum conducted power is > 0.8 W/Kg, low, middle and high channel are supposed to be tested.(3G/LTE/WLAN)
  3. When the highest reported SAR for 1 RB and 50% RB allocation are > 0.8 W/kg,SAR is measured for the highest output power channel in 100%RB.
  4. Start with the largest channel bandwidth and measure SAR for QPSK with 1 RB allocation, using the RB offset and required test channel combination with the highest maximum output power for RB offsets at the upper edge,middle and lower edge of each required test channel.



Index.	Position	Band	Ch.	Data Rate or Sub-Test	Side to Phantom	Spacing (mm)	SAR <sub>1g</sub> (W/Kg)	Power Drift	Burst Avg Power	Max tune-up	Reported SAR <sub>1g</sub>
#94	Flat	IEEE 802.11b	1	1M	1	10	0.046	-0.09	9.85	10	<b>0.048</b>
#95	Flat		1	1M	3	10	0.031	0.01	9.85	10	<b>0.032</b>

- Note: 1. According KDB 447498 D01 V05r02 section 4.1.4, the "Reported" explanation as below:  
 "When SAR or MPE is measured at or scaled to the maximum tune-up tolerance limit, the results are referred to as reported."
- The conducted power of (IEEE 802.11g / IEEE 802.11n) are not higher than IEEE 802.11b 0.25dB, (IEEE 802.11g / IEEE 802.11n) are not supposed to be tested.
  - If the Channel's Reported SAR 1g of maximum conducted power is > 0.8 W/Kg, low, middle and high channel are supposed to be tested.(3G/LTE/WLAN)



## 11.4 Extremity Measurement SAR

Evaluated extremity SAR is not available.

## 11.5 SAR Measurement Variability

Detailed evaluations please refer KDB 865664 on "SAR test reduction according to KDB" section.

Index.	Position	Band	Ch.	Test Mode or Sub-Test	Side to Phantom	Spacing (mm)	Number of times	SAR <sub>1g</sub> (W/Kg)	Power Drift	Burst Avg Power	Max tune-up	Reported SAR <sub>1g</sub> (W/Kg)	Repeated measurement Ratio
#33	Flat	WCDMA Band II	9400	RMC12.2K	1	10	1	1.07	0.03	23.83	24	1.113	1.05 < 1.2

Note: 1. According KDB 447498 D01 V05r02 section 4.1.4, the "Reported" explanation as below:

"When SAR or MPE is measured at or scaled to the maximum tune-up tolerance limit, the results are referred to as reported."

2. The original highest measured Reported SAR 1g is  $\geq 0.80$  W/kg, repeat that measurement once.

Index.	Position	Band	Ch.	BW (MHz)	RB Size	RB Offset	Side to Phantom	Spacing (mm)	Number of times	SAR <sub>1g</sub> (W/Kg)	Power Drift	Burst Avg Power	Max tune-up	Reported SAR <sub>1g</sub> (W/Kg)	Repeated measurement Ratio
#22	Flat	LTE Band 2 (QPSK)	18700	1	99	1	1	10	1	1.16	0.17	22.80	23.5	1.363	1.04 < 1.2
#23	Flat	LTE Band 2 (QPSK)	18700	1	99	1	1	10	2	1.19	-0.06	22.80	23.5	1.398	1.02 < 1.2
#100	Flat	LTE Band 2 (QPSK)	18700	1	99	1	1	10	3	1.12	-0.04	22.80	23.5	1.316	1.08 < 1.2
#54	Flat	LTE Band 4 (QPSK)	20300	1	0	1	1	10	1	1.14	0.14	22.31	23.0	1.336	1.08 < 1.2
#55	Flat	LTE Band 4 (QPSK)	20300	1	0	1	1	10	2	1.15	0.04	22.31	23.0	1.348	1.07 < 1.2
#99	Flat	LTE Band 4 (QPSK)	20300	1	0	1	1	10	3	1.13	-0.14	22.31	23.0	1.325	1.09 < 1.2
#91	Flat	LTE Band 17 (QPSK)	23780	1	0	1	1	10	1	1.18	-0.04	23.93	24.0	1.199	1.04 < 1.2

Note: 1. According KDB 447498 D01 V05r02 section 4.1.4, the "Reported" explanation as below:

"When SAR or MPE is measured at or scaled to the maximum tune-up tolerance limit, the results are referred to as reported."

2. The original highest measured Reported SAR 1g is  $\geq 0.80$  W/kg, repeat that measurement once.

3. The original highest measured Reported SAR 1g is  $\geq 1.2$  W/kg, repeat that measurement twice.

4. The original highest measured Reported SAR 1g is  $\geq 1.4$  W/kg, repeat that measurement three times.



## 11.6 Std. C95.1-1999 RF Exposure Limit

Human Exposure	Population Uncontrolled Exposure ( W/kg ) or (mW/g)	Occupational Controlled Exposure ( W/kg ) or (mW/g)
Spatial Peak SAR* (head)	1.60	8.00
Spatial Peak SAR** (Whole Body)	0.08	0.40
Spatial Peak SAR*** (Partial-Body)	1.60	8.00
Spatial Peak SAR**** (Hands / Feet / Ankle / Wrist )	4.00	20.00

Table 8. Safety Limits for Partial Body Exposure

### Notes :

- \* The Spatial Peak value of the SAR averaged over any 1 gram of tissue.  
( defined as a tissue volume in the shape of a cube ) and over the appropriate averaging time.
- \*\* The Spatial Average value of the SAR averaged over the whole – body.
- \*\*\* The Spatial Average value of the SAR averaged over the partial – body.
- \*\*\*\* The Spatial Peak value of the SAR averaged over any 10 grams of tissue.  
( defined as a tissue volume in the shape of a cube ) and over the appropriate averaging time.

**Population / Uncontrolled Environments** : are defined as locations where there is the exposure of individuals who have no knowledge or control of their exposure.

**Occupational / Controlled Environments** : are defined as locations where there is exposure that may be incurred by persons who are aware of the potential for exposure, (i.e. as a result of employment or occupation).



## 12. Conclusion

The SAR test values found for the portable mobile phone **Netgear Inc. Trade Name : Netgear Model(s) : AC779S-200** is below the maximum recommended level of 1.6 W/kg (mW/g).

## 13. References

- [1] Std. C95.1-1999, "American National Standard safety levels with respect to human exposure to radio frequency electromagnetic fields, 300KHz to 100GHz", New York.
- [2] NCRP, National Council on Radiation Protection and Measurements, "Biological Effects and Exposure Criteria for Radio frequency Electromagnetic Fields", NCRP report NO. 86, 1986.
- [3] T. Schmid, O. Egger, and N. Kuster, "Automatic E-field scanning system for dosimetric assessments", IEEE Transactions on Microwave Theory and Techniques, vol. 44, pp, 105-113, Jan. 1996.
- [4] K. Pokovi<sup>c</sup>, T. Schmid, and N. Kuster, "Robust setup for precise calibration of E-field probes in tissue simulating liquids at mobile communications frequency", in ICECOM'97, Dubrovnik, October 15-17, 1997, pp.120-124.
- [5] K. Pokovi<sup>c</sup>, T. Schmid, and N. Kuster, "E-field probe with improved isotropy in brain simulating liquids", in Proceedings of the ELMAR, Zadar, Croatia, 23-25 June, 1996, pp.172-175.
- [6] N. Kuster, and Q. Balzano, "Energy absorption mechanism by biological bodies in the near field of dipole antennas above 300MHz", IEEE Transaction on Vehicular Technology, vol. 41, no. 1, Feb. 1992, pp. 17-23.
- [7] Robert J. Renka, "Multivariate Interpolation Of Large Sets Of Scattered Data", University of North Texas ACM Transactions on Mathematical Software, vol. 14, no. 2, June 1988 , pp. 139-148.
- [8] N. Kuster, R. Kastle, T. Schmid, Dosimetric evaluation of mobile communications equipment with known precision, IEEE Transaction on Communications, vol. E80-B, no. 5, May 1997, pp. 645-652.
- [9] Std. C95.3-1991, "IEEE Recommended Practice for the Measurement of Potentially Hazardous Electromagnetic Fields – RF and Microwave, New York: IEEE, Aug. 1992.
- [10] CENELEC CLC/SC111B, European Prestandard (prENV 50166-2), Human Exposure to Electromagnetic Fields High-frequency: 10KHz-300GHz, Jan. 1995.
- [11] IEEE Std 1528™-2013 - IEEE Recommended Practice for Determining the Peak Spatial-Average Specific Absorption Rate (SAR) in the Human Head From Wireless Communications Devices: Measurement Techniques
- [12] IEEE Std 1528a™-2005 (Amendment to IEEE Std 1528™-2013), IEEE Recommended Practice for Determining the Peak Spatial-Average Specific Absorption Rate (SAR) in the Human Head from Wireless Communications Devices: Measurement Techniques



## **14. SAR Measurement Guidance**

- [1] KDB 865664 D01 SAR measurement 100 MHz to 6 GHz v01r03
- [2] KDB 447498 D01 General RF Exposure Guidance v05r02
- [3] KDB 248227 D01 SAR meas for 802 11 a b g v01r02.
- [4] KDB 941225 D01 3G SAR Procedures v03
- [5] KDB 941225 D05 SAR for LTE Devices v02r03
- [6] KDB 941225 D06 Hotspot Mode v02



## Appendix A - System Performance Check

Test Laboratory: A Test Lab Techno Corp.

Date: 2014/12/1 Time: PM 01:38:20

### System Performance Check at 750MHz\_20141201\_Body

**DUT: Dipole 750 MHz; Type: D750V3; Serial: D750V3 - SN:1004**

Communication System: UID 0, CW (0); Frequency: 750 MHz; Duty Cycle: 1:1

Medium parameters used:  $f = 750 \text{ MHz}$ ;  $\sigma = 1.01 \text{ S/m}$ ;  $\epsilon_r = 53.557$ ;  $\rho = 1000 \text{ kg/m}^3$

Phantom section: Flat Section

Measurement Standard: DASYS5 (IEEE/IEC/ANSI C63.19-2011)

DASY Configuration:

- Area Scan setting - Find Secondary Maximum Within: 2.0dB and with a peak SAR value greater than 0.5 W/Kg
- Probe: EX3DV4 - SN3977; ConvF(9.78, 9.78, 9.78); Calibrated: 2014/2/17;
- Sensor-Surface: 2mm (Mechanical Surface Detection)
- Electronics: DAE4 Sn779; Calibrated: 2014/2/25
- Phantom: ELI v5.0; Type: QDOVA002AA; Serial: TP:1133
- Measurement SW: DASYS52, Version 52.8 (7); SEMCAD X Version 14.6.10 (7164)

### System Performance Check at 750MHz/Area Scan (61x121x1):

Interpolated grid:  $dx=1.500 \text{ mm}$ ,  $dy=1.500 \text{ mm}$

Maximum value of SAR (interpolated) = 2.78 W/kg

### System Performance Check at 750MHz/Zoom Scan (7x7x7)/Cube 0:

Measurement grid:  $dx=5\text{mm}$ ,  $dy=5\text{mm}$ ,  $dz=5\text{mm}$

Reference Value = 53.387 V/m; Power Drift = -0.07 dB

Peak SAR (extrapolated) = 3.26 W/kg

**SAR(1 g) = 2.21 W/kg; SAR(10 g) = 1.46 W/kg**

Maximum value of SAR (measured) = 2.79 W/kg

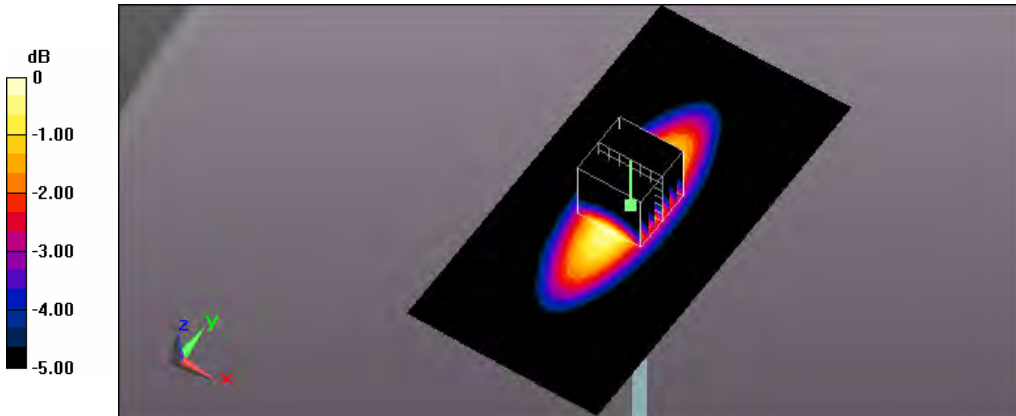

0 dB = 2.79 W/kg = 4.46 dBW/kg

Test Laboratory: A Test Lab Techno Corp.  
 Date: 2014/11/28 Time: AM 11:23:30

**System Performance Check at 835MHz\_20141128\_Body**

**DUT: Dipole 835 MHz; Type: D835V2; Serial: D835V2 - SN:4d082**

Communication System: UID 0, CW (0); Frequency: 835 MHz; Duty Cycle: 1:1

Medium parameters used:  $f = 835 \text{ MHz}$ ;  $\sigma = 0.99 \text{ S/m}$ ;  $\epsilon_r = 55.294$ ;  $\rho = 1000 \text{ kg/m}^3$

Phantom section: Flat Section

Measurement Standard: DASYS5 (IEEE/IEC/ANSI C63.19-2011)

DASY Configuration:

- Area Scan setting - Find Secondary Maximum Within: 2.0dB and with a peak SAR value greater than 0.5 W/Kg
- Probe: EX3DV4 - SN3977; ConvF(9.74, 9.74, 9.74); Calibrated: 2014/2/17;
- Sensor-Surface: 2mm (Mechanical Surface Detection)
- Electronics: DAE4 Sn779; Calibrated: 2014/2/25
- Phantom: ELI v5.0; Type: QDOVA002AA; Serial: TP:1133
- Measurement SW: DASYS52, Version 52.8 (7); SEMCAD X Version 14.6.10 (7164)

**System Performance Check at 835MHz/Area Scan (61x121x1):**

Interpolated grid:  $dx=1.500 \text{ mm}$ ,  $dy=1.500 \text{ mm}$

Maximum value of SAR (interpolated) = 3.15 W/kg

**System Performance Check at 835MHz/Zoom Scan (7x7x7)/Cube 0:**

Measurement grid:  $dx=5\text{mm}$ ,  $dy=5\text{mm}$ ,  $dz=5\text{mm}$

Reference Value = 55.157 V/m; Power Drift = 0.10 dB

Peak SAR (extrapolated) = 3.55 W/kg

**SAR(1 g) = 2.43 W/kg; SAR(10 g) = 1.61 W/kg**

Maximum value of SAR (measured) = 3.04 W/kg

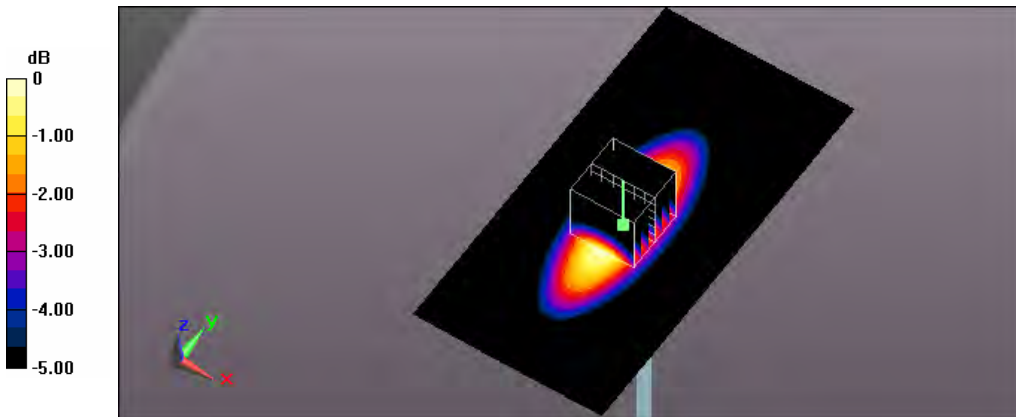

0 dB = 3.04 W/kg = 4.83 dBW/kg

Test Laboratory: A Test Lab Techno Corp.  
 Date: 2014/11/27 Time: PM 05:12:41

**System Performance Check at 1750MHz\_20141127\_Body**

**DUT: Dipole D1750V2\_SN1023; Type: D1750V2; Serial: D1750V2 - SN:1023**

Communication System: UID 0, CW (0); Frequency: 1750 MHz; Duty Cycle: 1:1

Medium parameters used:  $f = 1750 \text{ MHz}$ ;  $\sigma = 1.532 \text{ S/m}$ ;  $\epsilon_r = 54.292$ ;  $\rho = 1000 \text{ kg/m}^3$

Phantom section: Flat Section

Measurement Standard: DASY5 (IEEE/IEC/ANSI C63.19-2011)

DASY Configuration:

- Area Scan setting - Find Secondary Maximum Within: 2.0dB and with a peak SAR value greater than 0.5 W/Kg
- Probe: EX3DV4 - SN3977; ConvF(7.69, 7.69, 7.69); Calibrated: 2014/2/17;
- Sensor-Surface: 2mm (Mechanical Surface Detection)
- Electronics: DAE4 Sn779; Calibrated: 2014/2/25
- Phantom: ELI v5.0; Type: QDOVA002AA; Serial: TP:1133
- Measurement SW: DASY52, Version 52.8 (7); SEMCAD X Version 14.6.10 (7164)

**System Performance Check at 1750MHz/Area Scan (61x61x1):**

Interpolated grid:  $dx=1.500 \text{ mm}$ ,  $dy=1.500 \text{ mm}$

Maximum value of SAR (interpolated) = 14.5 W/kg

**System Performance Check at 1750MHz/Zoom Scan (7x7x7)/Cube 0:**

Measurement grid:  $dx=5\text{mm}$ ,  $dy=5\text{mm}$ ,  $dz=5\text{mm}$

Reference Value = 89.344 V/m; Power Drift = 0.06 dB

Peak SAR (extrapolated) = 16.7 W/kg

**SAR(1 g) = 9.38 W/kg; SAR(10 g) = 4.91 W/kg**

Maximum value of SAR (measured) = 13.4 W/kg

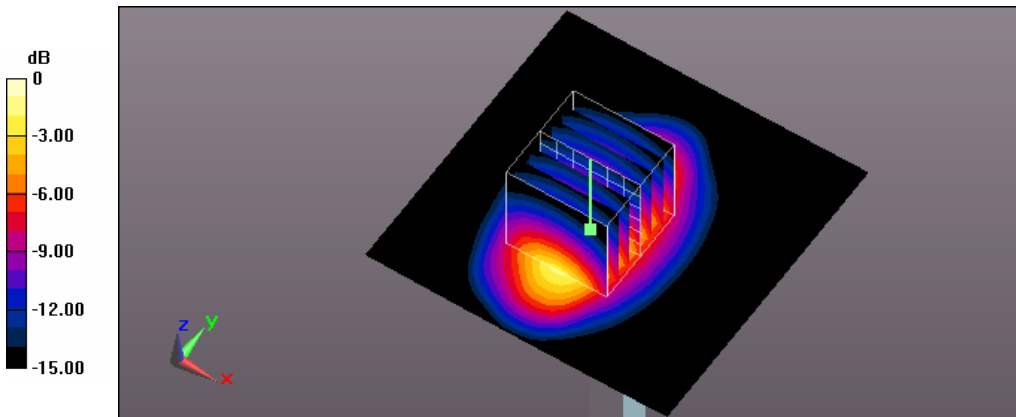

0 dB = 13.4 W/kg = 11.27 dBW/kg

Test Laboratory: A Test Lab Techno Corp.  
 Date: 2014/12/16 Time: PM 08:16:56

**System Performance Check at 1750MHz\_20141216\_Body**

**DUT: Dipole D1750V2\_SN1023; Type: D1750V2; Serial: D1750V2 - SN:1023**

Communication System: UID 0, CW (0); Frequency: 1750 MHz; Duty Cycle: 1:1

Medium parameters used:  $f = 1750 \text{ MHz}$ ;  $\sigma = 1.532 \text{ S/m}$ ;  $\epsilon_r = 54.292$ ;  $\rho = 1000 \text{ kg/m}^3$

Phantom section: Flat Section

Measurement Standard: DASY5 (IEEE/IEC/ANSI C63.19-2011)

DASY Configuration:

- Area Scan setting - Find Secondary Maximum Within: 2.0dB and with a peak SAR value greater than 0.5 W/Kg
- Probe: EX3DV4 - SN3977; ConvF(7.69, 7.69, 7.69); Calibrated: 2014/2/17;
- Sensor-Surface: 2mm (Mechanical Surface Detection)
- Electronics: DAE4 Sn779; Calibrated: 2014/2/25
- Phantom: ELI v5.0; Type: QDOVA002AA; Serial: TP:1133
- Measurement SW: DASY52, Version 52.8 (7); SEMCAD X Version 14.6.10 (7164)

**System Performance Check at 1750MHz/Area Scan (61x61x1):**

Interpolated grid:  $dx=1.500 \text{ mm}$ ,  $dy=1.500 \text{ mm}$

Maximum value of SAR (interpolated) = 13.2 W/kg

**System Performance Check at 1750MHz/Zoom Scan (7x7x7)/Cube 0:**

Measurement grid:  $dx=5\text{mm}$ ,  $dy=5\text{mm}$ ,  $dz=5\text{mm}$

Reference Value = 93.441 V/m; Power Drift = 0.05 dB

Peak SAR (extrapolated) = 16.7 W/kg

**SAR(1 g) = 9.3 W/kg; SAR(10 g) = 4.86 W/kg**

Maximum value of SAR (measured) = 13.3 W/kg

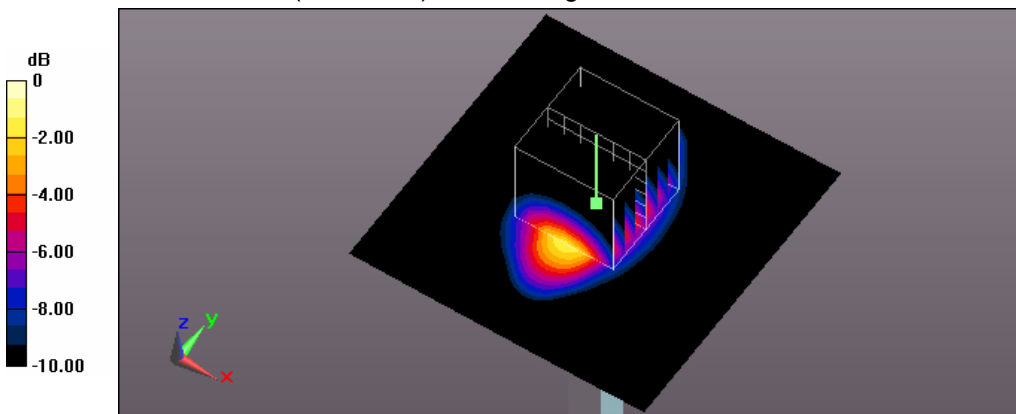

0 dB = 13.3 W/kg = 11.24 dBW/kg

Test Laboratory: A Test Lab Techno Corp.  
 Date: 2014/11/26 Time: PM 02:20:21

**System Performance Check at 1900MHz\_20141126\_Body**

**DUT: Dipole D1900V2\_SN5d111; Type: D1900V2; Serial: D1900V2 - SN:5d111**

Communication System: UID 0, CW (0); Frequency: 1900 MHz; Duty Cycle: 1:1

Medium parameters used:  $f = 1900 \text{ MHz}$ ;  $\sigma = 1.511 \text{ S/m}$ ;  $\epsilon_r = 51.635$ ;  $\rho = 1000 \text{ kg/m}^3$

Phantom section: Flat Section

Measurement Standard: DASY5 (IEEE/IEC/ANSI C63.19-2011)

DASY Configuration:

- Area Scan setting - Find Secondary Maximum Within: 2.0dB and with a peak SAR value greater than 0.5 W/Kg
- Probe: EX3DV4 - SN3977; ConvF(7.37, 7.37, 7.37); Calibrated: 2014/2/17;
- Sensor-Surface: 2mm (Mechanical Surface Detection)
- Electronics: DAE4 Sn779; Calibrated: 2014/2/25
- Phantom: ELI v5.0; Type: QDOVA002AA; Serial: TP:1133
- Measurement SW: DASY52, Version 52.8 (7); SEMCAD X Version 14.6.10 (7164)

**System Performance Check at 1900MHz/Area Scan (61x61x1):**

Interpolated grid:  $dx=1.500 \text{ mm}$ ,  $dy=1.500 \text{ mm}$

Maximum value of SAR (interpolated) = 15.3 W/kg

**System Performance Check at 1900MHz/Zoom Scan (7x7x7)/Cube 0:**

Measurement grid:  $dx=5\text{mm}$ ,  $dy=5\text{mm}$ ,  $dz=5\text{mm}$

Reference Value = 96.908 V/m; Power Drift = 0.00 dB

Peak SAR (extrapolated) = 18.1 W/kg

**SAR(1 g) = 10.1 W/kg; SAR(10 g) = 5.26 W/kg**

Maximum value of SAR (measured) = 14.4 W/kg

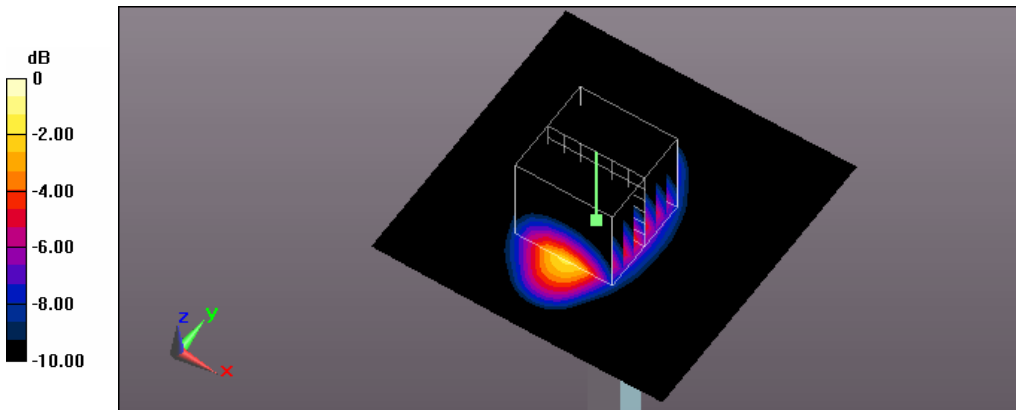

0 dB = 14.4 W/kg = 11.58 dBW/kg

Test Laboratory: A Test Lab Techno Corp.  
 Date: 2014/11/27 Time: PM 02:26:48

**System Performance Check at 1900MHz\_20141127\_Body**

**DUT: Dipole D1900V2\_SN5d111; Type: D1900V2; Serial: D1900V2 - SN:5d111**

Communication System: UID 0, CW (0); Frequency: 1900 MHz; Duty Cycle: 1:1

Medium parameters used:  $f = 1900 \text{ MHz}$ ;  $\sigma = 1.511 \text{ S/m}$ ;  $\epsilon_r = 51.635$ ;  $\rho = 1000 \text{ kg/m}^3$

Phantom section: Flat Section

Measurement Standard: DASY5 (IEEE/IEC/ANSI C63.19-2011)

DASY Configuration:

- Area Scan setting - Find Secondary Maximum Within: 2.0dB and with a peak SAR value greater than 0.5 W/Kg
- Probe: EX3DV4 - SN3977; ConvF(7.37, 7.37, 7.37); Calibrated: 2014/2/17;
- Sensor-Surface: 2mm (Mechanical Surface Detection)
- Electronics: DAE4 Sn779; Calibrated: 2014/2/25
- Phantom: ELI v5.0; Type: QDOVA002AA; Serial: TP:1133
- Measurement SW: DASY52, Version 52.8 (7); SEMCAD X Version 14.6.10 (7164)

**System Performance Check at 1900MHz/Area Scan (61x61x1):**

Interpolated grid:  $dx=1.500 \text{ mm}$ ,  $dy=1.500 \text{ mm}$

Maximum value of SAR (interpolated) = 15.7 W/kg

**System Performance Check at 1900MHz/Zoom Scan (7x7x7)/Cube 0:**

Measurement grid:  $dx=5\text{mm}$ ,  $dy=5\text{mm}$ ,  $dz=5\text{mm}$

Reference Value = 98.058 V/m; Power Drift = -0.10 dB

Peak SAR (extrapolated) = 17.8 W/kg

**SAR(1 g) = 9.97 W/kg; SAR(10 g) = 5.24 W/kg**

Maximum value of SAR (measured) = 14.1 W/kg

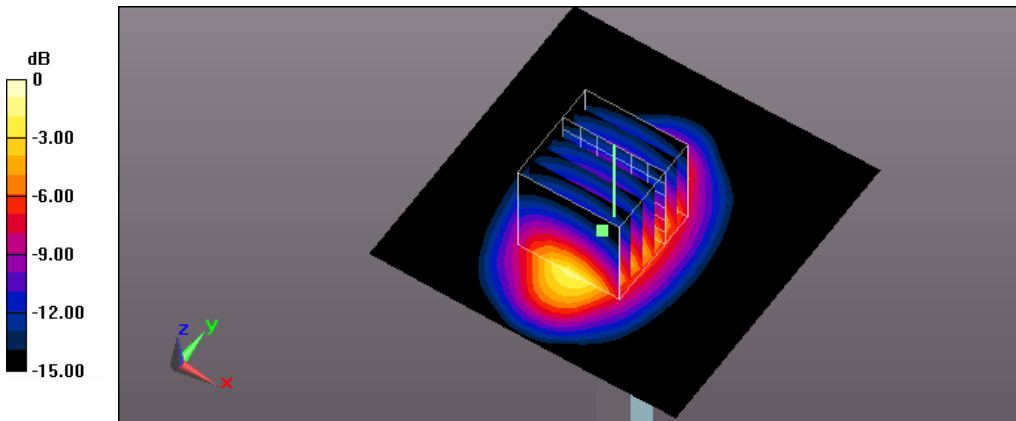

0 dB = 14.1 W/kg = 11.49 dBW/kg



Test Laboratory: A Test Lab Techno Corp.  
 Date: 2014/12/16 Time: PM 07:07:32

**System Performance Check at 1900MHz\_20141216\_Body**

**DUT: Dipole D1900V2\_SN5d111; Type: D1900V2; Serial: D1900V2 - SN:5d111**

Communication System: UID 0, CW (0); Frequency: 1900 MHz; Duty Cycle: 1:1

Medium parameters used:  $f = 1900 \text{ MHz}$ ;  $\sigma = 1.511 \text{ S/m}$ ;  $\epsilon_r = 51.635$ ;  $\rho = 1000 \text{ kg/m}^3$

Phantom section: Flat Section

Measurement Standard: DASY5 (IEEE/IEC/ANSI C63.19-2011)

DASY Configuration:

- Area Scan setting - Find Secondary Maximum Within: 2.0dB and with a peak SAR value greater than 0.5 W/Kg
- Probe: EX3DV4 - SN3977; ConvF(7.37, 7.37, 7.37); Calibrated: 2014/2/17;
- Sensor-Surface: 2mm (Mechanical Surface Detection)
- Electronics: DAE4 Sn779; Calibrated: 2014/2/25
- Phantom: ELI v5.0; Type: QDOVA002AA; Serial: TP:1133
- Measurement SW: DASY52, Version 52.8 (7); SEMCAD X Version 14.6.10 (7164)

**System Performance Check at 1900MHz/Area Scan (61x61x1):**

Interpolated grid:  $dx=1.500 \text{ mm}$ ,  $dy=1.500 \text{ mm}$

Maximum value of SAR (interpolated) = 14.6 W/kg

**System Performance Check at 1900MHz/Zoom Scan (7x7x7)/Cube 0:**

Measurement grid:  $dx=5\text{mm}$ ,  $dy=5\text{mm}$ ,  $dz=5\text{mm}$

Reference Value = 99.075 V/m; Power Drift = 0.05 dB

Peak SAR (extrapolated) = 18.5 W/kg

**SAR(1 g) = 10.2 W/kg; SAR(10 g) = 5.29 W/kg**

Maximum value of SAR (measured) = 14.6 W/kg

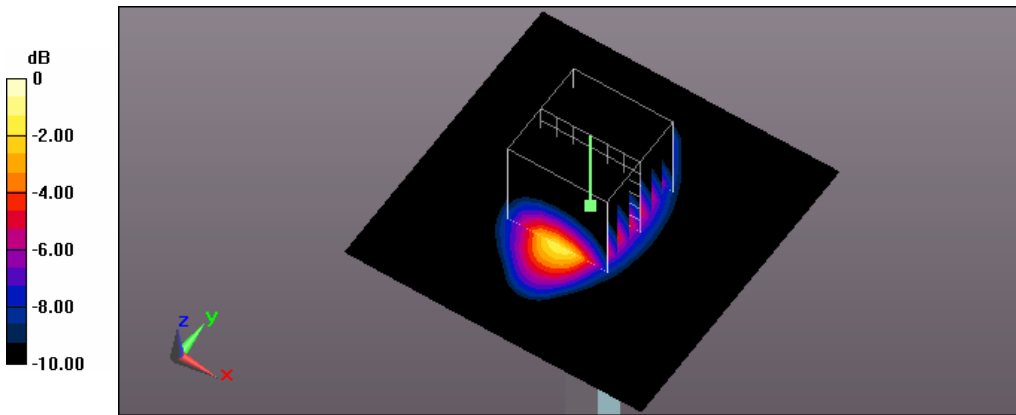

0 dB = 14.6 W/kg = 11.64 dBW/kg

Test Laboratory: A Test Lab Techno Corp.  
 Date: 2015/1/16 Time: PM 02:01:30

**System Performance Check at 1900MHz\_20150116\_Body**

**DUT: Dipole D1900V2\_SN5d111; Type: D1900V2; Serial: D1900V2 - SN:5d111**

Communication System: UID 0, CW (0); Frequency: 1900 MHz; Duty Cycle: 1:1

Medium parameters used:  $f = 1900 \text{ MHz}$ ;  $\sigma = 1.511 \text{ S/m}$ ;  $\epsilon_r = 51.635$ ;  $\rho = 1000 \text{ kg/m}^3$

Phantom section: Flat Section

Measurement Standard: DASYS (IEEE/IEC/ANSI C63.19-2011)

DASY Configuration:

- Area Scan setting - Find Secondary Maximum Within: 2.0dB and with a peak SAR value greater than 0.5 W/Kg
- Probe: EX3DV4 - SN3977; ConvF(7.37, 7.37, 7.37); Calibrated: 2014/2/17;
- Sensor-Surface: 2mm (Mechanical Surface Detection)
- Electronics: DAE4 Sn779; Calibrated: 2014/2/25
- Phantom: ELI v5.0; Type: QDOVA002AA; Serial: TP:1133
- Measurement SW: DASYS2, Version 52.8 (7); SEMCAD X Version 14.6.10 (7164)

**System Performance Check at 1900MHz/Area Scan (61x61x1):**

Interpolated grid:  $dx=1.500 \text{ mm}$ ,  $dy=1.500 \text{ mm}$

Maximum value of SAR (interpolated) = 14.4 W/kg

**System Performance Check at 1900MHz/Zoom Scan (7x7x7)/Cube 0:**

Measurement grid:  $dx=5\text{mm}$ ,  $dy=5\text{mm}$ ,  $dz=5\text{mm}$

Reference Value = 98.532 V/m; Power Drift = 0.04 dB

Peak SAR (extrapolated) = 18.4 W/kg

**SAR(1 g) = 10.1 W/kg; SAR(10 g) = 5.2 W/kg**

Maximum value of SAR (measured) = 14.5 W/kg

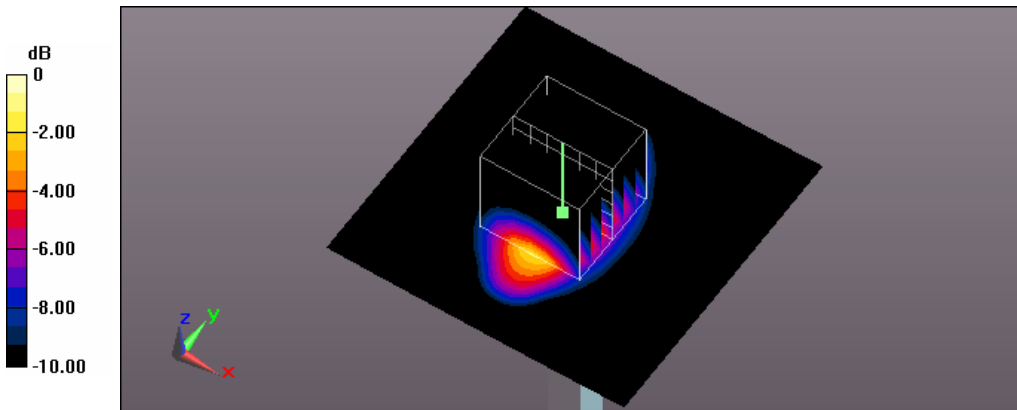

0 dB = 14.5 W/kg = 11.61 dBW/kg

Test Laboratory: A Test Lab Techno Corp.  
 Date: 2014/12/5 Time: PM 03:00:13

**System Performance Check at 2450MHz\_20141205\_Body**

**DUT: Dipole 2450 MHz; Type: D2450V2; Serial: D2450V2 - SN:712**

Communication System: UID 0, CW (0); Frequency: 2450 MHz; Duty Cycle: 1:1

Medium parameters used:  $f = 2450 \text{ MHz}$ ;  $\sigma = 1.98 \text{ S/m}$ ;  $\epsilon_r = 54.458$ ;  $\rho = 1000 \text{ kg/m}^3$

Phantom section: Flat Section

Measurement Standard: DASY5 (IEEE/IEC/ANSI C63.19-2011)

DASY Configuration:

- Area Scan setting - Find Secondary Maximum Within: 2.0dB and with a peak SAR value greater than 0.5 W/Kg
- Probe: EX3DV4 - SN3977; ConvF(6.97, 6.97, 6.97); Calibrated: 2014/2/17;
- Sensor-Surface: 2mm (Mechanical Surface Detection)
- Electronics: DAE4 Sn779; Calibrated: 2014/2/25
- Phantom: ELI v5.0; Type: QDOVA002AA; Serial: TP:1133
- Measurement SW: DASY52, Version 52.8 (7); SEMCAD X Version 14.6.10 (7164)

**System Performance Check at 2450MHz/Area Scan (61x61x1):**

Interpolated grid:  $dx=1.500 \text{ mm}$ ,  $dy=1.500 \text{ mm}$

Maximum value of SAR (interpolated) = 19.9 W/kg

**System Performance Check at 2450MHz/Zoom Scan (7x7x7)/Cube 0:**

Measurement grid:  $dx=5\text{mm}$ ,  $dy=5\text{mm}$ ,  $dz=5\text{mm}$

Reference Value = 100.6 V/m; Power Drift = 0.01 dB

Peak SAR (extrapolated) = 27.0 W/kg

**SAR(1 g) = 13 W/kg; SAR(10 g) = 6 W/kg**

Maximum value of SAR (measured) = 20.0 W/kg

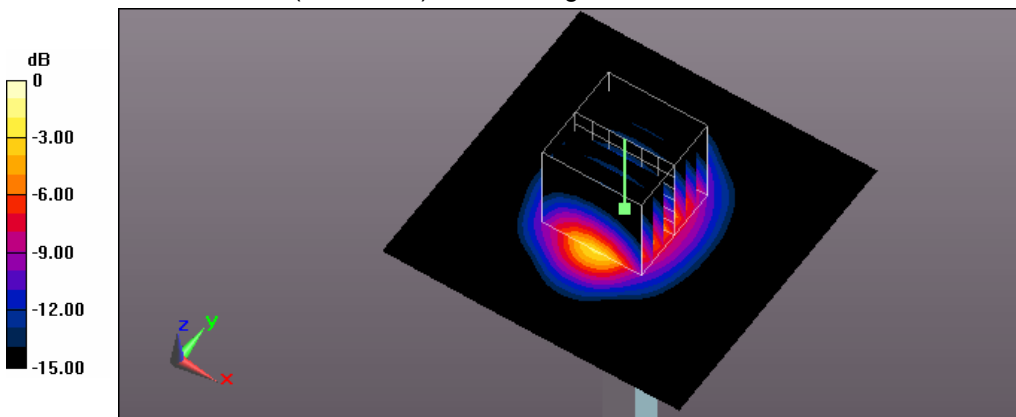

0 dB = 20.0 W/kg = 13.01 dBW/kg

## Appendix B - SAR Measurement Data

Test Laboratory: A Test Lab Techno Corp.

Date: 2015/1/16 Time: PM 03:52:55

**25\_Flat\_WCDMA BandII CH9262\_side 1 surface to phantom 10mm**

**DUT: AC779S-200; Type: Mobile Hot Spot; Serial: 01426000002034**

Communication System: UID 0, WCDMA Band II (0); Frequency: 1852.4 MHz; Duty Cycle: 1:1

Medium parameters used (interpolated):  $f = 1852.4$  MHz;  $\sigma = 1.465$  S/m;  $\epsilon_r = 51.822$ ;  $\rho = 1000$  kg/m<sup>3</sup>

Phantom section: Flat Section

Measurement Standard: DASYS5 (IEEE/IEC/ANSI C63.19-2011)

DASY Configuration:

- Area Scan setting - Find Secondary Maximum Within: 2.0dB and with a peak SAR value greater than 0.5 W/Kg
- Probe: EX3DV4 - SN3977; ConvF(7.37, 7.37, 7.37); Calibrated: 2014/2/17;
- Sensor-Surface: 2mm (Mechanical Surface Detection)
- Electronics: DAE4 Sn779; Calibrated: 2014/2/25
- Phantom: ELI v5.0; Type: QDOVA002AA; Serial: TP:1133
- Measurement SW: DASYS5, Version 52.8 (7); SEMCAD X Version 14.6.10 (7164)

### Flat/Area Scan (81x121x1):

Interpolated grid: dx=1.500 mm, dy=1.500 mm

Maximum value of SAR (interpolated) = 1.57 W/kg

### Flat/Zoom Scan (5x5x7)/Cube 0:

Measurement grid: dx=8mm, dy=8mm, dz=5mm

Reference Value = 12.409 V/m; Power Drift = -0.02 dB

Peak SAR (extrapolated) = 1.93 W/kg

**SAR(1 g) = 1.13 W/kg; SAR(10 g) = 0.635 W/kg**

Maximum value of SAR (measured) = 1.54 W/kg

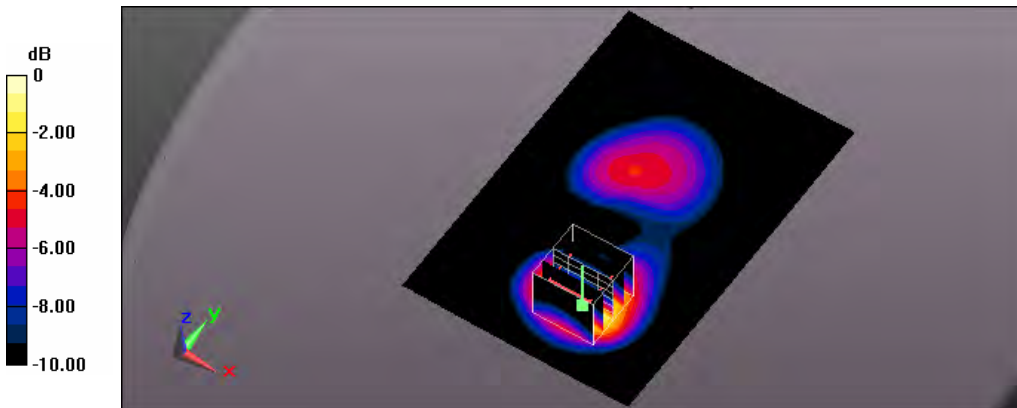

0 dB = 1.54 W/kg = 1.88 dBW/kg

Test Laboratory: A Test Lab Techno Corp.

Date: 2015/1/16 Time: PM 09:40:28

**31\_Flat\_WCDMA BandII CH9262\_side 5 surface to phantom 10mm**

**DUT: AC779S-200; Type: Mobile Hot Spot; Serial: 01426000002034**

Communication System: UID 0, WCDMA Band II (0); Frequency: 1852.4 MHz; Duty Cycle: 1:1

Medium parameters used (interpolated):  $f = 1852.4$  MHz;  $\sigma = 1.465$  S/m;  $\epsilon_r = 51.822$ ;  $\rho = 1000$  kg/m<sup>3</sup>

Phantom section: Flat Section

Measurement Standard: DASYS (IEEE/IEC/ANSI C63.19-2011)

DASY Configuration:

- Area Scan setting - Find Secondary Maximum Within: 2.0dB and with a peak SAR value greater than 0.5 W/Kg
- Probe: EX3DV4 - SN3977; ConvF(7.37, 7.37, 7.37); Calibrated: 2014/2/17;
- Sensor-Surface: 2mm (Mechanical Surface Detection)
- Electronics: DAE4 Sn779; Calibrated: 2014/2/25
- Phantom: ELI v5.0; Type: QDOVA002AA; Serial: TP:1133
- Measurement SW: DASYS2, Version 52.8 (7); SEMCAD X Version 14.6.10 (7164)

**Flat/Area Scan (61x101x1):**

Interpolated grid: dx=1.500 mm, dy=1.500 mm

Maximum value of SAR (interpolated) = 1.63 W/kg

**Flat/Zoom Scan (5x5x7)/Cube 0:**

Measurement grid: dx=8mm, dy=8mm, dz=5mm

Reference Value = 29.017 V/m; Power Drift = 0.03 dB

Peak SAR (extrapolated) = 1.87 W/kg

**SAR(1 g) = 1.12 W/kg; SAR(10 g) = 0.623 W/kg**

Maximum value of SAR (measured) = 1.50 W/kg

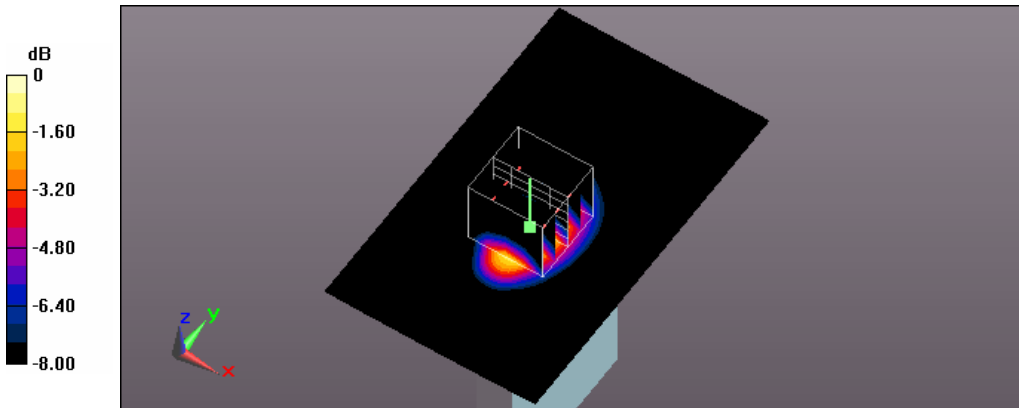

0 dB = 1.50 W/kg = 1.76 dBW/kg

Test Laboratory: A Test Lab Techno Corp.

Date: 2015/1/16 Time: PM 06:22:53

**101\_Flat\_WCDMA BandII CH9262\_side 2 surface to phantom 10mm**

**DUT: AC779S-200; Type: Mobile Hot Spot; Serial: 01426000002034**

Communication System: UID 0, WCDMA Band II (0); Frequency: 1852.4 MHz; Duty Cycle: 1:1

Medium parameters used (interpolated):  $f = 1852.4$  MHz;  $\sigma = 1.465$  S/m;  $\epsilon_r = 51.822$ ;  $\rho = 1000$  kg/m<sup>3</sup>

Phantom section: Flat Section

Measurement Standard: DASYS (IEEE/IEC/ANSI C63.19-2011)

DASY Configuration:

- Area Scan setting - Find Secondary Maximum Within: 2.0dB and with a peak SAR value greater than 0.5 W/Kg
- Probe: EX3DV4 - SN3977; ConvF(7.37, 7.37, 7.37); Calibrated: 2014/2/17;
- Sensor-Surface: 2mm (Mechanical Surface Detection)
- Electronics: DAE4 Sn779; Calibrated: 2014/2/25
- Phantom: ELI v5.0; Type: QDOVA002AA; Serial: TP:1133
- Measurement SW: DASYS2, Version 52.8 (7); SEMCAD X Version 14.6.10 (7164)

**Flat/Area Scan (81x121x1):**

Interpolated grid: dx=1.500 mm, dy=1.500 mm

Maximum value of SAR (interpolated) = 1.04 W/kg

**Flat/Zoom Scan (5x5x7)/Cube 0:**

Measurement grid: dx=8mm, dy=8mm, dz=5mm

Reference Value = 17.772 V/m; Power Drift = -0.04 dB

Peak SAR (extrapolated) = 1.23 W/kg

**SAR(1 g) = 0.742 W/kg; SAR(10 g) = 0.436 W/kg**

Maximum value of SAR (measured) = 1.00 W/kg

**Flat/Zoom Scan (5x5x7)/Cube 1:**

Measurement grid: dx=8mm, dy=8mm, dz=5mm

Reference Value = 17.772 V/m; Power Drift = -0.04 dB

Peak SAR (extrapolated) = 0.755 W/kg

**SAR(1 g) = 0.502 W/kg; SAR(10 g) = 0.323 W/kg**

Maximum value of SAR (measured) = 0.634 W/kg

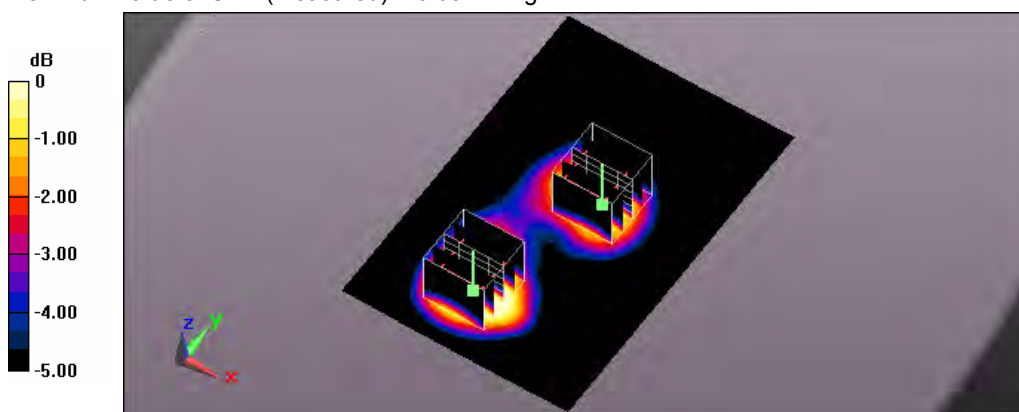

0 dB = 0.634 W/kg = -1.98 dBW/kg

Test Laboratory: A Test Lab Techno Corp.

Date: 2015/1/16 Time: PM 03:19:11

**24\_Flat\_WCDMA BandII CH9400\_side 1 surface to phantom 10mm**

**DUT: AC779S-200; Type: Mobile Hot Spot; Serial: 01426000002034**

Communication System: UID 0, WCDMA Band II (0); Frequency: 1880 MHz; Duty Cycle: 1:1

Medium parameters used:  $f = 1880 \text{ MHz}$ ;  $\sigma = 1.487 \text{ S/m}$ ;  $\epsilon_r = 51.76$ ;  $\rho = 1000 \text{ kg/m}^3$

Phantom section: Flat Section

Measurement Standard: DASYS (IEEE/IEC/ANSI C63.19-2011)

DASY Configuration:

- Area Scan setting - Find Secondary Maximum Within: 2.0dB and with a peak SAR value greater than 0.5 W/Kg
- Probe: EX3DV4 - SN3977; ConvF(7.37, 7.37, 7.37); Calibrated: 2014/2/17;
- Sensor-Surface: 2mm (Mechanical Surface Detection)
- Electronics: DAE4 Sn779; Calibrated: 2014/2/25
- Phantom: ELI v5.0; Type: QDOVA002AA; Serial: TP:1133
- Measurement SW: DASYS2, Version 52.8 (7); SEMCAD X Version 14.6.10 (7164)

**Flat/Area Scan (81x121x1):**

Interpolated grid:  $dx=1.500 \text{ mm}$ ,  $dy=1.500 \text{ mm}$

Maximum value of SAR (interpolated) = 1.53 W/kg

**Flat/Zoom Scan (5x5x7)/Cube 0:**

Measurement grid:  $dx=8\text{mm}$ ,  $dy=8\text{mm}$ ,  $dz=5\text{mm}$

Reference Value = 12.286 V/m; Power Drift = 0.01 dB

Peak SAR (extrapolated) = 1.91 W/kg

**SAR(1 g) = 1.11 W/kg; SAR(10 g) = 0.630 W/kg**

Maximum value of SAR (measured) = 1.53 W/kg

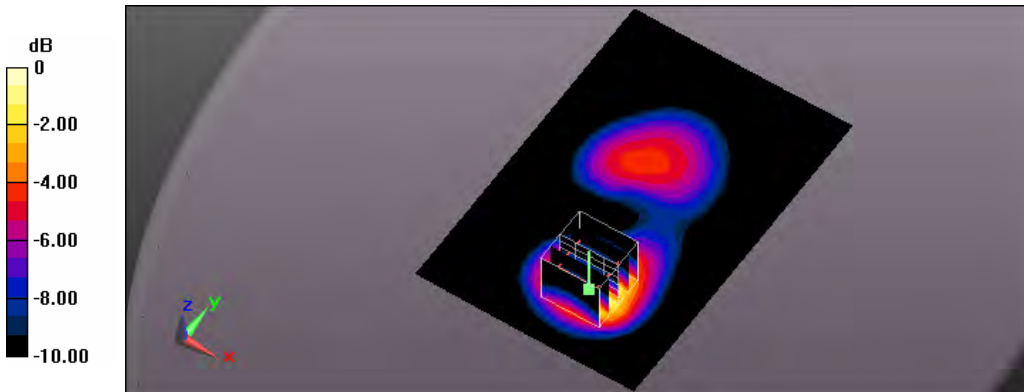

0 dB = 1.53 W/kg = 1.85 dBW/kg

Test Laboratory: A Test Lab Techno Corp.

Date: 2015/1/16 Time: PM 05:38:10

**27 Flat\_WCDMA BandII CH9400\_side 2 surface to phantom 10mm**

**DUT: AC779S-200; Type: Mobile Hot Spot; Serial: 01426000002034**

Communication System: UID 0, WCDMA Band II (0); Frequency: 1880 MHz; Duty Cycle: 1:1

Medium parameters used:  $f = 1880 \text{ MHz}$ ;  $\sigma = 1.487 \text{ S/m}$ ;  $\epsilon_r = 51.76$ ;  $\rho = 1000 \text{ kg/m}^3$

Phantom section: Flat Section

Measurement Standard: DASYS (IEEE/IEC/ANSI C63.19-2011)

DASY Configuration:

- Area Scan setting - Find Secondary Maximum Within: 2.0dB and with a peak SAR value greater than 0.5 W/Kg
- Probe: EX3DV4 - SN3977; ConvF(7.37, 7.37, 7.37); Calibrated: 2014/2/17;
- Sensor-Surface: 2mm (Mechanical Surface Detection)
- Electronics: DAE4 Sn779; Calibrated: 2014/2/25
- Phantom: ELI v5.0; Type: QDOVA002AA; Serial: TP:1133
- Measurement SW: DASYS2, Version 52.8 (7); SEMCAD X Version 14.6.10 (7164)

**Flat/Area Scan (81x121x1):**

Interpolated grid:  $dx=1.500 \text{ mm}$ ,  $dy=1.500 \text{ mm}$

Maximum value of SAR (interpolated) = 1.06 W/kg

**Flat/Zoom Scan (5x5x7)/Cube 0:**

Measurement grid:  $dx=8\text{mm}$ ,  $dy=8\text{mm}$ ,  $dz=5\text{mm}$

Reference Value = 16.171 V/m; Power Drift = -0.07 dB

Peak SAR (extrapolated) = 1.29 W/kg

**SAR(1 g) = 0.772 W/kg; SAR(10 g) = 0.458 W/kg**

Maximum value of SAR (measured) = 1.04 W/kg

**Flat/Zoom Scan (5x5x7)/Cube 1:**

Measurement grid:  $dx=8\text{mm}$ ,  $dy=8\text{mm}$ ,  $dz=5\text{mm}$

Reference Value = 16.171 V/m; Power Drift = -0.07 dB

Peak SAR (extrapolated) = 0.847 W/kg

**SAR(1 g) = 0.557 W/kg; SAR(10 g) = 0.355 W/kg**

Maximum value of SAR (measured) = 0.710 W/kg

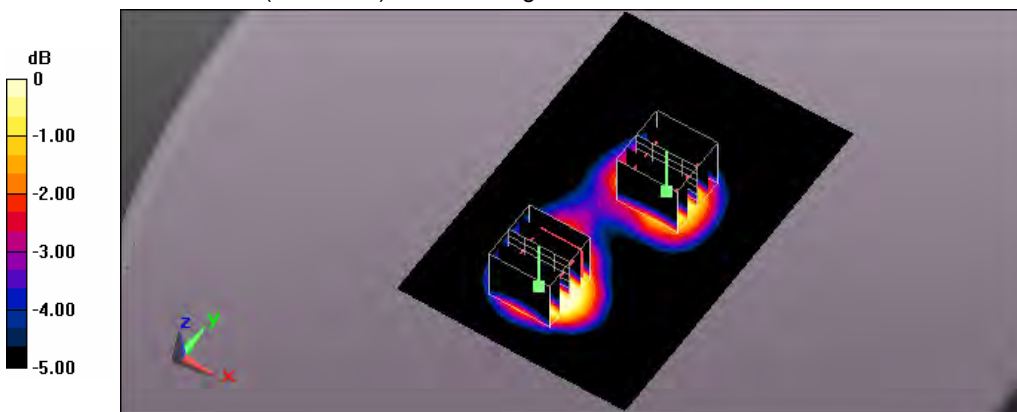

0 dB = 0.710 W/kg = -1.49 dBW/kg



Test Laboratory: A Test Lab Techno Corp.

Date: 2015/1/16 Time: PM 07:40:18

**28 Flat\_WCDMA BandII CH9400\_side 3 surface to phantom 10mm**

**DUT: AC779S-200; Type: Mobile Hot Spot; Serial: 01426000002034**

Communication System: UID 0, WCDMA Band II (0); Frequency: 1880 MHz; Duty Cycle: 1:1

Medium parameters used:  $f = 1880 \text{ MHz}$ ;  $\sigma = 1.487 \text{ S/m}$ ;  $\epsilon_r = 51.76$ ;  $\rho = 1000 \text{ kg/m}^3$

Phantom section: Flat Section

Measurement Standard: DASYS (IEEE/IEC/ANSI C63.19-2011)

DASY Configuration:

- Area Scan setting - Find Secondary Maximum Within: 2.0dB and with a peak SAR value greater than 0.5 W/Kg
- Probe: EX3DV4 - SN3977; ConvF(7.37, 7.37, 7.37); Calibrated: 2014/2/17;
- Sensor-Surface: 2mm (Mechanical Surface Detection)
- Electronics: DAE4 Sn779; Calibrated: 2014/2/25
- Phantom: ELI v5.0; Type: QDOVA002AA; Serial: TP:1133
- Measurement SW: DASYS2, Version 52.8 (7); SEMCAD X Version 14.6.10 (7164)

**Flat/Area Scan (61x111x1):**

Interpolated grid:  $dx=1.500 \text{ mm}$ ,  $dy=1.500 \text{ mm}$

Maximum value of SAR (interpolated) = 0.174 W/kg

**Flat/Zoom Scan (5x5x7)/Cube 0:**

Measurement grid:  $dx=8\text{mm}$ ,  $dy=8\text{mm}$ ,  $dz=5\text{mm}$

Reference Value = 10.554 V/m; Power Drift = 0.03 dB

Peak SAR (extrapolated) = 0.198 W/kg

**SAR(1 g) = 0.126 W/kg; SAR(10 g) = 0.076 W/kg**

Maximum value of SAR (measured) = 0.162 W/kg

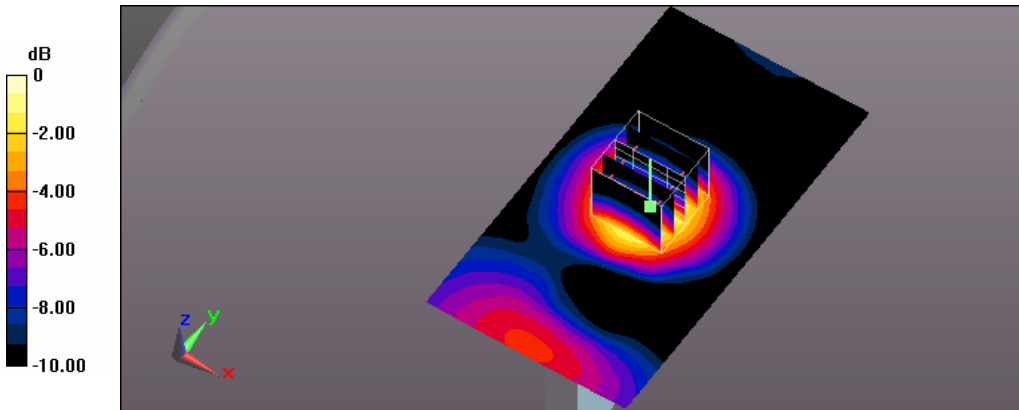

0 dB = 0.162 W/kg = -7.90 dBW/kg

Test Laboratory: A Test Lab Techno Corp.

Date: 2015/1/16 Time: PM 08:24:05

**29 Flat\_WCDMA BandII CH9400\_side 4 surface to phantom 10mm**

**DUT: AC779S-200; Type: Mobile Hot Spot; Serial: 01426000002034**

Communication System: UID 0, WCDMA Band II (0); Frequency: 1880 MHz; Duty Cycle: 1:1

Medium parameters used:  $f = 1880 \text{ MHz}$ ;  $\sigma = 1.487 \text{ S/m}$ ;  $\epsilon_r = 51.76$ ;  $\rho = 1000 \text{ kg/m}^3$

Phantom section: Flat Section

Measurement Standard: DASYS (IEEE/IEC/ANSI C63.19-2011)

DASY Configuration:

- Area Scan setting - Find Secondary Maximum Within: 2.0dB and with a peak SAR value greater than 0.5 W/Kg
- Probe: EX3DV4 - SN3977; ConvF(7.37, 7.37, 7.37); Calibrated: 2014/2/17;
- Sensor-Surface: 2mm (Mechanical Surface Detection)
- Electronics: DAE4 Sn779; Calibrated: 2014/2/25
- Phantom: ELI v5.0; Type: QDOVA002AA; Serial: TP:1133
- Measurement SW: DASYS2, Version 52.8 (7); SEMCAD X Version 14.6.10 (7164)

**Flat/Area Scan (61x111x1):**

Interpolated grid:  $dx=1.500 \text{ mm}$ ,  $dy=1.500 \text{ mm}$

Maximum value of SAR (interpolated) = 0.722 W/kg

**Flat/Zoom Scan (5x5x7)/Cube 0:**

Measurement grid:  $dx=8\text{mm}$ ,  $dy=8\text{mm}$ ,  $dz=5\text{mm}$

Reference Value = 19.151 V/m; Power Drift = -0.02 dB

Peak SAR (extrapolated) = 0.878 W/kg

**SAR(1 g) = 0.544 W/kg; SAR(10 g) = 0.322 W/kg**

Maximum value of SAR (measured) = 0.714 W/kg

**Flat/Zoom Scan (5x5x7)/Cube 1:**

Measurement grid:  $dx=8\text{mm}$ ,  $dy=8\text{mm}$ ,  $dz=5\text{mm}$

Reference Value = 19.151 V/m; Power Drift = -0.02 dB

Peak SAR (extrapolated) = 0.664 W/kg

**SAR(1 g) = 0.404 W/kg; SAR(10 g) = 0.249 W/kg**

Maximum value of SAR (measured) = 0.547 W/kg

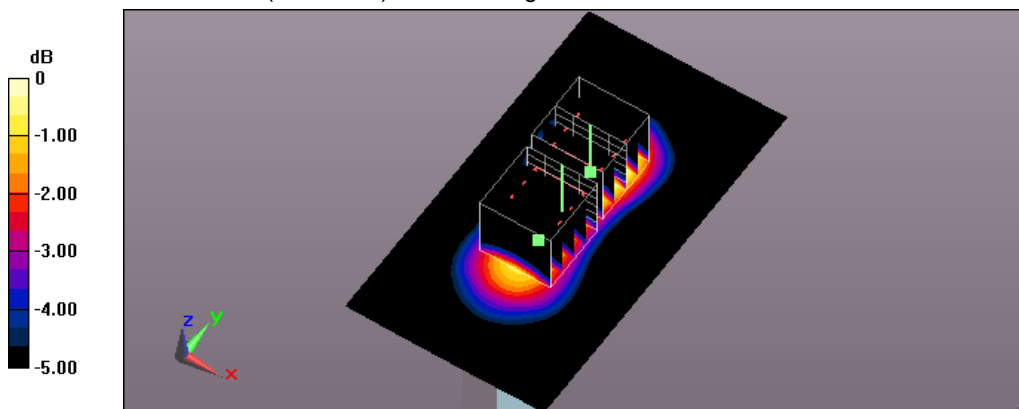

0 dB = 0.547 W/kg = -2.62 dBW/kg

Test Laboratory: A Test Lab Techno Corp.

Date: 2015/1/16 Time: PM 09:21:15

**30\_Flat\_WCDMA BandII CH9400\_side 5 surface to phantom 10mm**

**DUT: AC779S-200; Type: Mobile Hot Spot; Serial: 01426000002034**

Communication System: UID 0, WCDMA Band II (0); Frequency: 1880 MHz; Duty Cycle: 1:1

Medium parameters used:  $f = 1880 \text{ MHz}$ ;  $\sigma = 1.487 \text{ S/m}$ ;  $\epsilon_r = 51.76$ ;  $\rho = 1000 \text{ kg/m}^3$

Phantom section: Flat Section

Measurement Standard: DASY5 (IEEE/IEC/ANSI C63.19-2011)

DASY Configuration:

- Area Scan setting - Find Secondary Maximum Within: 2.0dB and with a peak SAR value greater than 0.5 W/Kg
- Probe: EX3DV4 - SN3977; ConvF(7.37, 7.37, 7.37); Calibrated: 2014/2/17;
- Sensor-Surface: 2mm (Mechanical Surface Detection)
- Electronics: DAE4 Sn779; Calibrated: 2014/2/25
- Phantom: ELI v5.0; Type: QDOVA002AA; Serial: TP:1133
- Measurement SW: DASY52, Version 52.8 (7); SEMCAD X Version 14.6.10 (7164)

**Flat/Area Scan (61x101x1):**

Interpolated grid:  $dx=1.500 \text{ mm}$ ,  $dy=1.500 \text{ mm}$

Maximum value of SAR (interpolated) = 1.56 W/kg

**Flat/Zoom Scan (5x5x7)/Cube 0:**

Measurement grid:  $dx=8\text{mm}$ ,  $dy=8\text{mm}$ ,  $dz=5\text{mm}$

Reference Value = 28.917 V/m; Power Drift = 0.00 dB

Peak SAR (extrapolated) = 1.84 W/kg

**SAR(1 g) = 1.08 W/kg; SAR(10 g) = 0.597 W/kg**

Maximum value of SAR (measured) = 1.48 W/kg

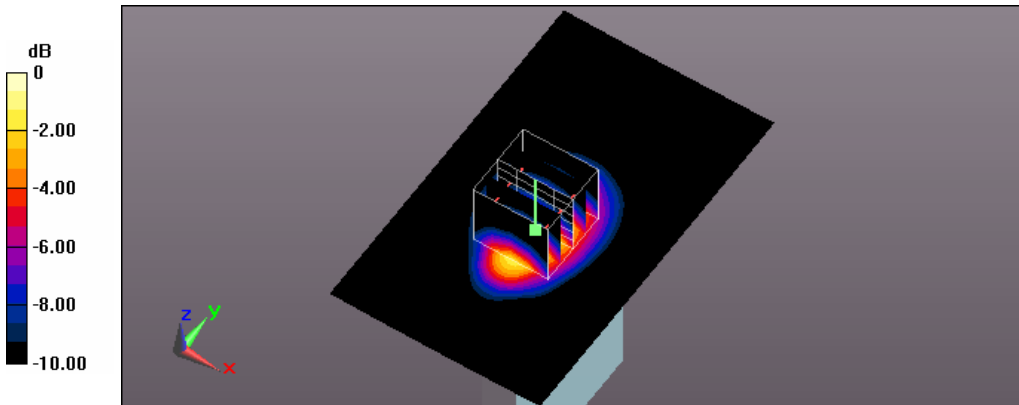

0 dB = 1.48 W/kg = 1.70 dBW/kg

Test Laboratory: A Test Lab Techno Corp.

Date: 2015/1/16 Time: PM 04:16:17

**26 Flat\_WCDMA BandII CH9538\_side 1 surface to phantom 10mm**

**DUT: AC779S-200; Type: Mobile Hot Spot; Serial: 01426000002034**

Communication System: UID 0, WCDMA Band II (0); Frequency: 1907.6 MHz; Duty Cycle: 1:1

Medium parameters used:  $f = 1908 \text{ MHz}$ ;  $\sigma = 1.521 \text{ S/m}$ ;  $\epsilon_r = 51.611$ ;  $\rho = 1000 \text{ kg/m}^3$

Phantom section: Flat Section

Measurement Standard: DASYS (IEEE/IEC/ANSI C63.19-2011)

DASY Configuration:

- Area Scan setting - Find Secondary Maximum Within: 2.0dB and with a peak SAR value greater than 0.5 W/Kg
- Probe: EX3DV4 - SN3977; ConvF(7.37, 7.37, 7.37); Calibrated: 2014/2/17;
- Sensor-Surface: 2mm (Mechanical Surface Detection)
- Electronics: DAE4 Sn779; Calibrated: 2014/2/25
- Phantom: ELI v5.0; Type: QDOVA002AA; Serial: TP:1133
- Measurement SW: DASYS2, Version 52.8 (7); SEMCAD X Version 14.6.10 (7164)

**Flat/Area Scan (81x121x1):**

Interpolated grid:  $dx=1.500 \text{ mm}$ ,  $dy=1.500 \text{ mm}$

Maximum value of SAR (interpolated) = 1.42 W/kg

**Flat/Zoom Scan (5x5x7)/Cube 0:**

Measurement grid:  $dx=8\text{mm}$ ,  $dy=8\text{mm}$ ,  $dz=5\text{mm}$

Reference Value = 11.970 V/m; Power Drift = 0.04 dB

Peak SAR (extrapolated) = 1.77 W/kg

**SAR(1 g) = 1.03 W/kg; SAR(10 g) = 0.593 W/kg**

Maximum value of SAR (measured) = 1.41 W/kg

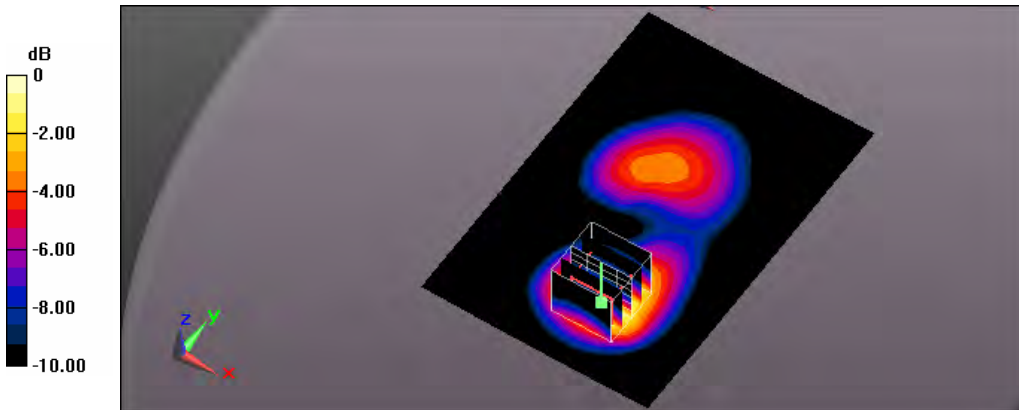

0 dB = 1.41 W/kg = 1.49 dBW/kg

Test Laboratory: A Test Lab Techno Corp.

Date: 2015/1/16 Time: PM 09:58:19

**32 Flat\_WCDMA BandII CH9538\_side 5 surface to phantom 10mm**

**DUT: AC779S-200; Type: Mobile Hot Spot; Serial: 01426000002034**

Communication System: UID 0, WCDMA Band II (0); Frequency: 1907.6 MHz; Duty Cycle: 1:1

Medium parameters used:  $f = 1908 \text{ MHz}$ ;  $\sigma = 1.521 \text{ S/m}$ ;  $\epsilon_r = 51.611$ ;  $\rho = 1000 \text{ kg/m}^3$

Phantom section: Flat Section

Measurement Standard: DASYS (IEEE/IEC/ANSI C63.19-2011)

DASY Configuration:

- Area Scan setting - Find Secondary Maximum Within: 2.0dB and with a peak SAR value greater than 0.5 W/Kg
- Probe: EX3DV4 - SN3977; ConvF(7.37, 7.37, 7.37); Calibrated: 2014/2/17;
- Sensor-Surface: 2mm (Mechanical Surface Detection)
- Electronics: DAE4 Sn779; Calibrated: 2014/2/25
- Phantom: ELI v5.0; Type: QDOVA002AA; Serial: TP:1133
- Measurement SW: DASYS2, Version 52.8 (7); SEMCAD X Version 14.6.10 (7164)

**Flat/Area Scan (61x101x1):**

Interpolated grid:  $dx=1.500 \text{ mm}$ ,  $dy=1.500 \text{ mm}$

Maximum value of SAR (interpolated) = 1.41 W/kg

**Flat/Zoom Scan (5x5x7)/Cube 0:**

Measurement grid:  $dx=8\text{mm}$ ,  $dy=8\text{mm}$ ,  $dz=5\text{mm}$

Reference Value = 27.497 V/m; Power Drift = -0.03 dB

Peak SAR (extrapolated) = 1.66 W/kg

**SAR(1 g) = 0.976 W/kg; SAR(10 g) = 0.538 W/kg**

Maximum value of SAR (measured) = 1.33 W/kg

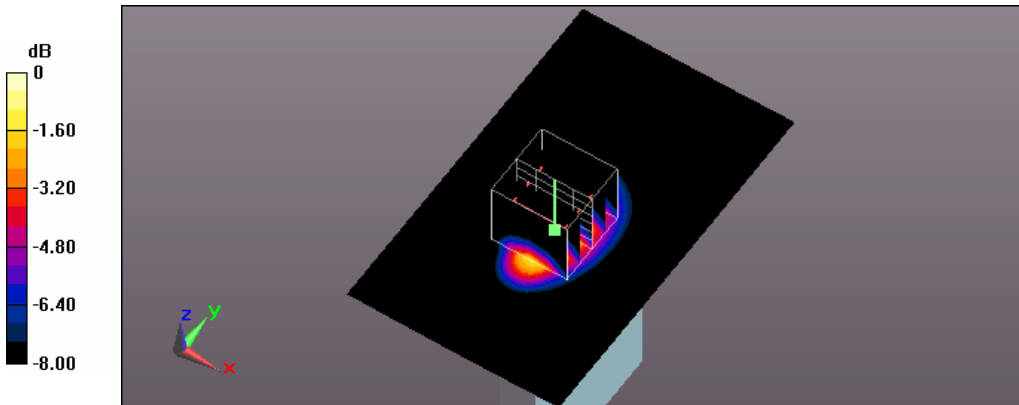

0 dB = 1.33 W/kg = 1.24 dBW/kg

Test Laboratory: A Test Lab Techno Corp.

Date: 2015/1/16 Time: PM 06:59:32

**102\_Flat\_WCDMA BandII CH9538\_side 2 surface to phantom 10mm**

**DUT: AC779S-200; Type: Mobile Hot Spot; Serial: 01426000002034**

Communication System: UID 0, WCDMA Band II (0); Frequency: 1907.6 MHz; Duty Cycle: 1:1

Medium parameters used:  $f = 1908 \text{ MHz}$ ;  $\sigma = 1.521 \text{ S/m}$ ;  $\epsilon_r = 51.611$ ;  $\rho = 1000 \text{ kg/m}^3$

Phantom section: Flat Section

Measurement Standard: DASYS (IEEE/IEC/ANSI C63.19-2011)

DASY Configuration:

- Area Scan setting - Find Secondary Maximum Within: 2.0dB and with a peak SAR value greater than 0.5 W/Kg
- Probe: EX3DV4 - SN3977; ConvF(7.37, 7.37, 7.37); Calibrated: 2014/2/17;
- Sensor-Surface: 2mm (Mechanical Surface Detection)
- Electronics: DAE4 Sn779; Calibrated: 2014/2/25
- Phantom: ELI v5.0; Type: QDOVA002AA; Serial: TP:1133
- Measurement SW: DASYS2, Version 52.8 (7); SEMCAD X Version 14.6.10 (7164)

**Flat/Area Scan (81x121x1):**

Interpolated grid:  $dx=1.500 \text{ mm}$ ,  $dy=1.500 \text{ mm}$

Maximum value of SAR (interpolated) = 1.08 W/kg

**Flat/Zoom Scan (5x5x7)/Cube 0:**

Measurement grid:  $dx=8\text{mm}$ ,  $dy=8\text{mm}$ ,  $dz=5\text{mm}$

Reference Value = 17.523 V/m; Power Drift = -0.02 dB

Peak SAR (extrapolated) = 1.24 W/kg

**SAR(1 g) = 0.747 W/kg; SAR(10 g) = 0.451 W/kg**

Maximum value of SAR (measured) = 0.999 W/kg

**Flat/Zoom Scan (5x5x7)/Cube 1:**

Measurement grid:  $dx=8\text{mm}$ ,  $dy=8\text{mm}$ ,  $dz=5\text{mm}$

Reference Value = 17.523 V/m; Power Drift = -0.02 dB

Peak SAR (extrapolated) = 0.866 W/kg

**SAR(1 g) = 0.564 W/kg; SAR(10 g) = 0.356 W/kg**

Maximum value of SAR (measured) = 0.720 W/kg

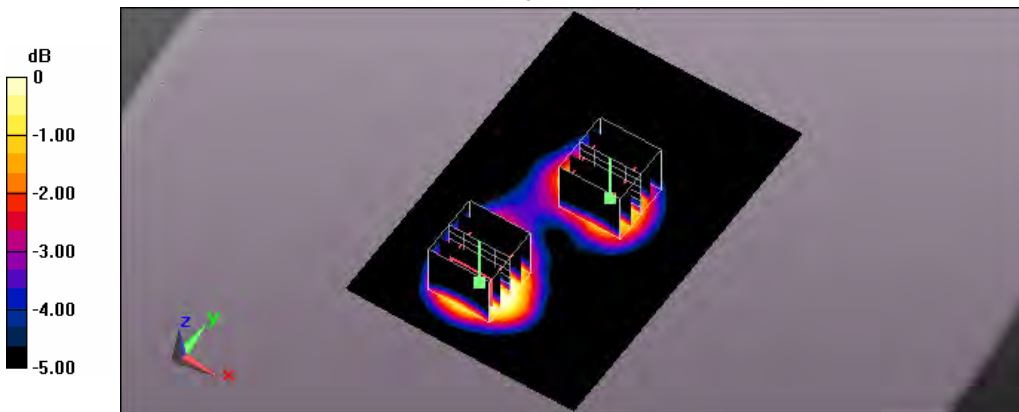

0 dB = 0.720 W/kg = -1.43 dBW/kg

Test Laboratory: A Test Lab Techno Corp.

Date: 2014/11/28 Time: PM 12:06:04

**56 Flat WCDMA Band V CH4233\_side 1 surface to phantom 10mm**

**DUT: AC779S-200; Type: Mobile Hot Spot; Serial: 01426000002034**

Communication System: UID 0, WCDMA Band V (0); Frequency: 846.6 MHz; Duty Cycle: 1:1

Medium parameters used:  $f = 847 \text{ MHz}$ ;  $\sigma = 1.006 \text{ S/m}$ ;  $\epsilon_r = 55.296$ ;  $\rho = 1000 \text{ kg/m}^3$

Phantom section: Flat Section

Measurement Standard: DASYS (IEEE/IEC/ANSI C63.19-2011)

DASY Configuration:

- Area Scan setting - Find Secondary Maximum Within: 2.0dB and with a peak SAR value greater than 0.5 W/Kg
- Probe: EX3DV4 - SN3977; ConvF(9.74, 9.74, 9.74); Calibrated: 2014/2/17;
- Sensor-Surface: 2mm (Mechanical Surface Detection)
- Electronics: DAE4 Sn779; Calibrated: 2014/2/25
- Phantom: ELI v5.0; Type: QDOVA002AA; Serial: TP:1133
- Measurement SW: DASYS2, Version 52.8 (7); SEMCAD X Version 14.6.10 (7164)

**Flat/Area Scan (81x121x1):**

Interpolated grid:  $dx=1.500 \text{ mm}$ ,  $dy=1.500 \text{ mm}$

Maximum value of SAR (interpolated) = 0.822 W/kg

**Flat/Zoom Scan (5x5x7)/Cube 0:**

Measurement grid:  $dx=8\text{mm}$ ,  $dy=8\text{mm}$ ,  $dz=5\text{mm}$

Reference Value = 20.670 V/m; Power Drift = -0.03 dB

Peak SAR (extrapolated) = 0.944 W/kg

**SAR(1 g) = 0.658 W/kg; SAR(10 g) = 0.451 W/kg**

Maximum value of SAR (measured) = 0.816 W/kg

**Flat/Zoom Scan (5x5x7)/Cube 1:**

Measurement grid:  $dx=8\text{mm}$ ,  $dy=8\text{mm}$ ,  $dz=5\text{mm}$

Reference Value = 20.670 V/m; Power Drift = -0.03 dB

Peak SAR (extrapolated) = 0.914 W/kg

**SAR(1 g) = 0.533 W/kg; SAR(10 g) = 0.330 W/kg**

Maximum value of SAR (measured) = 0.762 W/kg

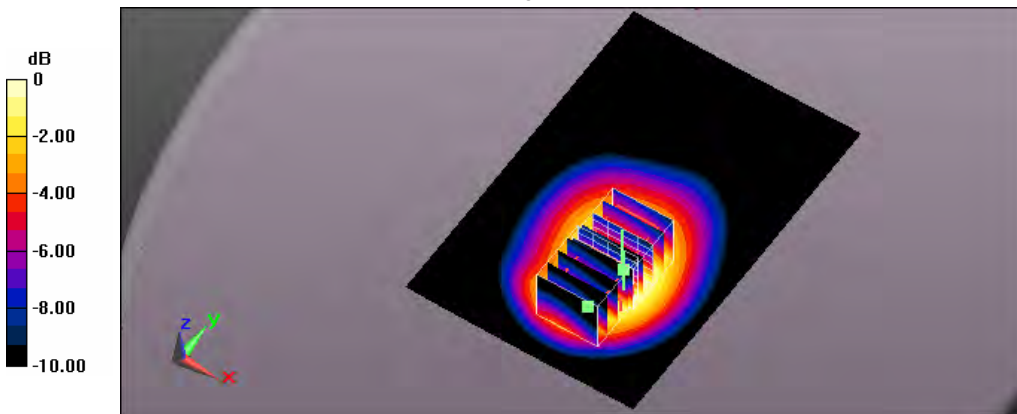

0 dB = 0.762 W/kg = -1.18 dBW/kg

Test Laboratory: A Test Lab Techno Corp.

Date: 2014/11/28 Time: PM 01:14:18

**57\_Flat\_WCDMA BandV CH4233\_side 2 surface to phantom 10mm**

**DUT: AC779S-200; Type: Mobile Hot Spot; Serial: 01426000002034**

Communication System: UID 0, WCDMA Band V (0); Frequency: 846.6 MHz; Duty Cycle: 1:1

Medium parameters used:  $f = 847 \text{ MHz}$ ;  $\sigma = 1.006 \text{ S/m}$ ;  $\epsilon_r = 55.296$ ;  $\rho = 1000 \text{ kg/m}^3$

Phantom section: Flat Section

Measurement Standard: DASYS (IEEE/IEC/ANSI C63.19-2011)

DASY Configuration:

- Area Scan setting - Find Secondary Maximum Within: 2.0dB and with a peak SAR value greater than 0.5 W/Kg
- Probe: EX3DV4 - SN3977; ConvF(9.74, 9.74, 9.74); Calibrated: 2014/2/17;
- Sensor-Surface: 2mm (Mechanical Surface Detection)
- Electronics: DAE4 Sn779; Calibrated: 2014/2/25
- Phantom: ELI v5.0; Type: QDOVA002AA; Serial: TP:1133
- Measurement SW: DASYS2, Version 52.8 (7); SEMCAD X Version 14.6.10 (7164)

**Flat/Area Scan (81x121x1):**

Interpolated grid:  $dx=1.500 \text{ mm}$ ,  $dy=1.500 \text{ mm}$

Maximum value of SAR (interpolated) = 0.719 W/kg

**Flat/Zoom Scan (5x5x7)/Cube 0:**

Measurement grid:  $dx=8\text{mm}$ ,  $dy=8\text{mm}$ ,  $dz=5\text{mm}$

Reference Value = 20.051 V/m; Power Drift = -0.03 dB

Peak SAR (extrapolated) = 0.813 W/kg

**SAR(1 g) = 0.587 W/kg; SAR(10 g) = 0.411 W/kg**

Maximum value of SAR (measured) = 0.713 W/kg

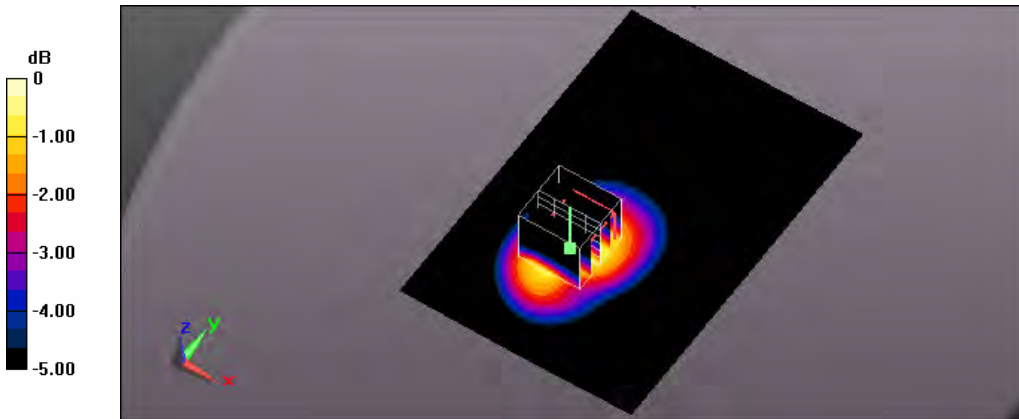

0 dB = 0.713 W/kg = -1.47 dBW/kg



Test Laboratory: A Test Lab Techno Corp.

Date: 2014/11/28 Time: PM 01:49:33

**58 Flat\_WCDMA BandV CH4233\_side 3 surface to phantom 10mm**

**DUT: AC779S-200; Type: Mobile Hot Spot; Serial: 01426000002034**

Communication System: UID 0, WCDMA Band V (0); Frequency: 846.6 MHz; Duty Cycle: 1:1

Medium parameters used:  $f = 847 \text{ MHz}$ ;  $\sigma = 1.006 \text{ S/m}$ ;  $\epsilon_r = 55.296$ ;  $\rho = 1000 \text{ kg/m}^3$

Phantom section: Flat Section

Measurement Standard: DASY5 (IEEE/IEC/ANSI C63.19-2011)

DASY Configuration:

- Area Scan setting - Find Secondary Maximum Within: 2.0dB and with a peak SAR value greater than 0.5 W/Kg
- Probe: EX3DV4 - SN3977; ConvF(9.74, 9.74, 9.74); Calibrated: 2014/2/17;
- Sensor-Surface: 2mm (Mechanical Surface Detection)
- Electronics: DAE4 Sn779; Calibrated: 2014/2/25
- Phantom: ELI v5.0; Type: QDOVA002AA; Serial: TP:1133
- Measurement SW: DASY52, Version 52.8 (7); SEMCAD X Version 14.6.10 (7164)

**Flat/Area Scan (61x111x1):**

Interpolated grid:  $dx=1.500 \text{ mm}$ ,  $dy=1.500 \text{ mm}$

Maximum value of SAR (interpolated) = 0.277 W/kg

**Flat/Zoom Scan (5x5x7)/Cube 0:**

Measurement grid:  $dx=8\text{mm}$ ,  $dy=8\text{mm}$ ,  $dz=5\text{mm}$

Reference Value = 14.927 V/m; Power Drift = -0.06 dB

Peak SAR (extrapolated) = 0.310 W/kg

**SAR(1 g) = 0.230 W/kg; SAR(10 g) = 0.164 W/kg**

Maximum value of SAR (measured) = 0.275 W/kg

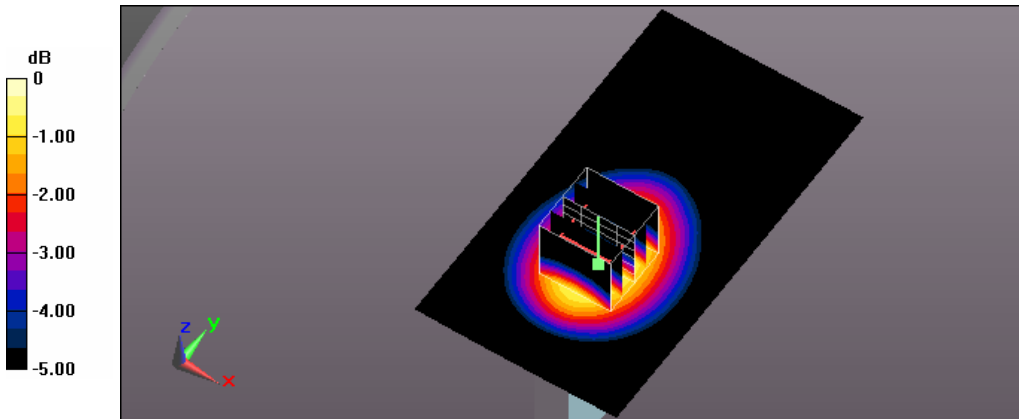

0 dB = 0.275 W/kg = -5.61 dBW/kg

Test Laboratory: A Test Lab Techno Corp.

Date: 2014/11/28 Time: PM 02:15:45

**59\_Flat\_WCDMA BandV CH4233\_side 4 surface to phantom 10mm**

**DUT: AC779S-200; Type: Mobile Hot Spot; Serial: 01426000002034**

Communication System: UID 0, WCDMA Band V (0); Frequency: 846.6 MHz; Duty Cycle: 1:1

Medium parameters used:  $f = 847 \text{ MHz}$ ;  $\sigma = 1.006 \text{ S/m}$ ;  $\epsilon_r = 55.296$ ;  $\rho = 1000 \text{ kg/m}^3$

Phantom section: Flat Section

Measurement Standard: DASY5 (IEEE/IEC/ANSI C63.19-2011)

DASY Configuration:

- Area Scan setting - Find Secondary Maximum Within: 2.0dB and with a peak SAR value greater than 0.5 W/Kg
- Probe: EX3DV4 - SN3977; ConvF(9.74, 9.74, 9.74); Calibrated: 2014/2/17;
- Sensor-Surface: 2mm (Mechanical Surface Detection)
- Electronics: DAE4 Sn779; Calibrated: 2014/2/25
- Phantom: ELI v5.0; Type: QDOVA002AA; Serial: TP:1133
- Measurement SW: DASY52, Version 52.8 (7); SEMCAD X Version 14.6.10 (7164)

**Flat/Area Scan (61x111x1):**

Interpolated grid:  $dx=1.500 \text{ mm}$ ,  $dy=1.500 \text{ mm}$

Maximum value of SAR (interpolated) = 0.278 W/kg

**Flat/Zoom Scan (5x5x7)/Cube 0:**

Measurement grid:  $dx=8\text{mm}$ ,  $dy=8\text{mm}$ ,  $dz=5\text{mm}$

Reference Value = 16.647 V/m; Power Drift = -0.05 dB

Peak SAR (extrapolated) = 0.324 W/kg

**SAR(1 g) = 0.228 W/kg; SAR(10 g) = 0.155 W/kg**

Maximum value of SAR (measured) = 0.280 W/kg

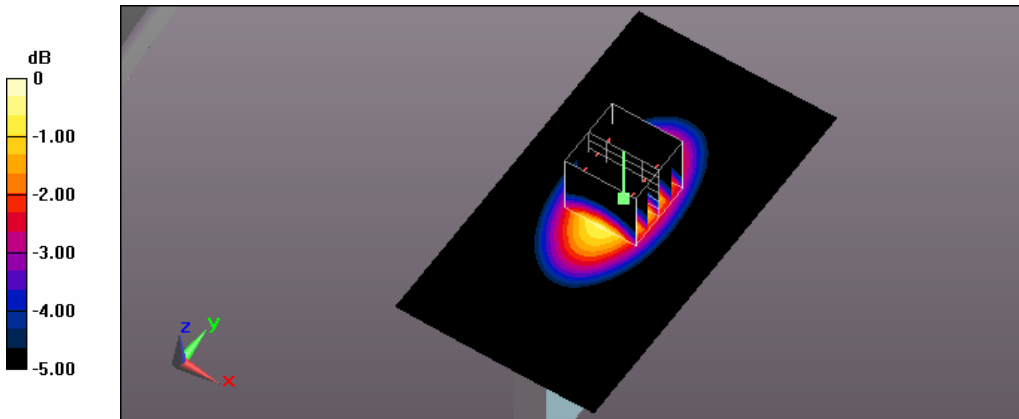

0 dB = 0.280 W/kg = -5.53 dBW/kg

Test Laboratory: A Test Lab Techno Corp.

Date: 2014/11/28 Time: PM 02:43:49

**60\_Flat\_WCDMA BandV CH4233\_side 5 surface to phantom 10mm**

**DUT: AC779S-200; Type: Mobile Hot Spot; Serial: 01426000002034**

Communication System: UID 0, WCDMA Band V (0); Frequency: 846.6 MHz; Duty Cycle: 1:1

Medium parameters used:  $f = 847 \text{ MHz}$ ;  $\sigma = 1.006 \text{ S/m}$ ;  $\epsilon_r = 55.296$ ;  $\rho = 1000 \text{ kg/m}^3$

Phantom section: Flat Section

Measurement Standard: DASYS (IEEE/IEC/ANSI C63.19-2011)

DASY Configuration:

- Area Scan setting - Find Secondary Maximum Within: 2.0dB and with a peak SAR value greater than 0.5 W/Kg
- Probe: EX3DV4 - SN3977; ConvF(9.74, 9.74, 9.74); Calibrated: 2014/2/17;
- Sensor-Surface: 2mm (Mechanical Surface Detection)
- Electronics: DAE4 Sn779; Calibrated: 2014/2/25
- Phantom: ELI v5.0; Type: QDOVA002AA; Serial: TP:1133
- Measurement SW: DASYS2, Version 52.8 (7); SEMCAD X Version 14.6.10 (7164)

**Flat/Area Scan (61x101x1):**

Interpolated grid:  $dx=1.500 \text{ mm}$ ,  $dy=1.500 \text{ mm}$

Maximum value of SAR (interpolated) = 0.172 W/kg

**Flat/Zoom Scan (5x5x7)/Cube 0:**

Measurement grid:  $dx=8\text{mm}$ ,  $dy=8\text{mm}$ ,  $dz=5\text{mm}$

Reference Value = 11.819 V/m; Power Drift = -0.07 dB

Peak SAR (extrapolated) = 0.206 W/kg

**SAR(1 g) = 0.127 W/kg; SAR(10 g) = 0.076 W/kg**

Maximum value of SAR (measured) = 0.169 W/kg

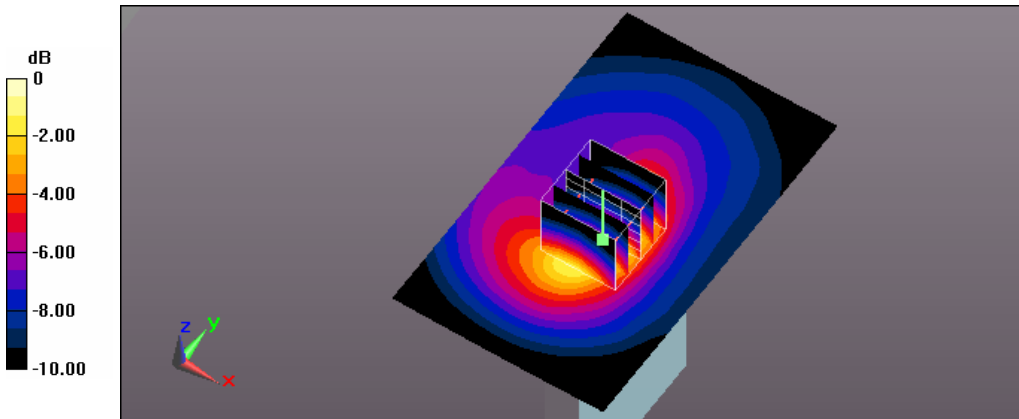

0 dB = 0.169 W/kg = -7.72 dBW/kg

Test Laboratory: A Test Lab Techno Corp.

Date: 2014/11/27 Time: PM 04:16:44

**33 Flat\_WCDMA BandII CH9400\_original #24\_side 1 surface to phantom 10mm\_measurement onece  
DUT: AC779S-200; Type: Mobile Hot Spot; Serial: 01426000002034**

Communication System: UID 0, WCDMA Band II (0); Frequency: 1880 MHz; Duty Cycle: 1:1

Medium parameters used:  $f = 1880 \text{ MHz}$ ;  $\sigma = 1.458 \text{ S/m}$ ;  $\epsilon_r = 52.636$ ;  $\rho = 1000 \text{ kg/m}^3$

Phantom section: Flat Section

Measurement Standard: DASYS (IEEE/IEC/ANSI C63.19-2011)

DASY Configuration:

- Area Scan setting - Find Secondary Maximum Within: 2.0dB and with a peak SAR value greater than 0.5 W/Kg
- Probe: EX3DV4 - SN3977; ConvF(7.37, 7.37, 7.37); Calibrated: 2014/2/17;
- Sensor-Surface: 2mm (Mechanical Surface Detection)
- Electronics: DAE4 Sn779; Calibrated: 2014/2/25
- Phantom: ELI v5.0; Type: QDOVA002AA; Serial: TP:1133
- Measurement SW: DASYS2, Version 52.8 (7); SEMCAD X Version 14.6.10 (7164)

**Flat/Area Scan (81x121x1):**

Interpolated grid:  $dx=1.500 \text{ mm}$ ,  $dy=1.500 \text{ mm}$

Maximum value of SAR (interpolated) = 1.48 W/kg

**Flat/Zoom Scan (5x5x7)/Cube 0:**

Measurement grid:  $dx=8\text{mm}$ ,  $dy=8\text{mm}$ ,  $dz=5\text{mm}$

Reference Value = 16.851 V/m; Power Drift = 0.03 dB

Peak SAR (extrapolated) = 1.82 W/kg

**SAR(1 g) = 1.07 W/kg; SAR(10 g) = 0.597 W/kg**

Maximum value of SAR (measured) = 1.45 W/kg

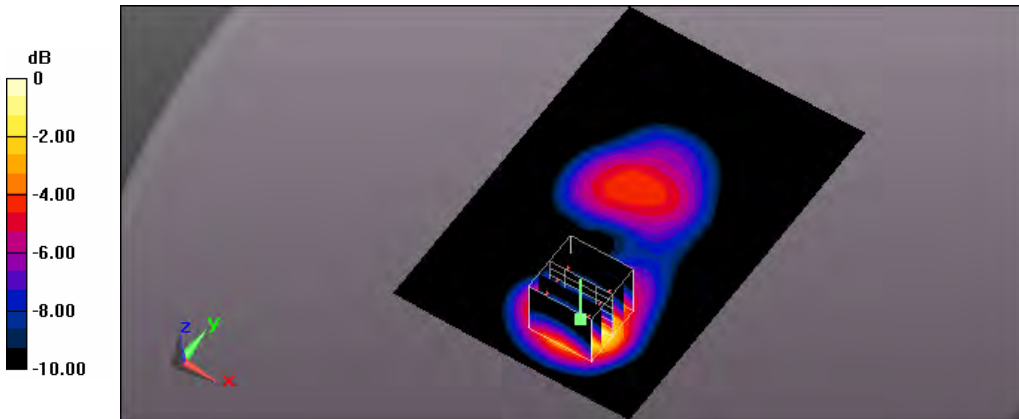

0 dB = 1.45 W/kg = 1.61 dBW/kg

Test Laboratory: A Test Lab Techno Corp.

Date: 2014/11/26 Time: PM 03:40:36

**1\_Flat\_LTE Band2 BW 20M CH18700\_QPSK with 1 RB Size 99 RB Offset side 1 surface to phantom 10mm**

**DUT: AC779S-200; Type: Mobile Hot Spot; Serial: 01426000002034**

Communication System: UID 0, Generic LTE (0); Frequency: 1860 MHz; Duty Cycle: 1:1

Medium parameters used:  $f = 1860$  MHz;  $\sigma = 1.472$  S/m;  $\epsilon_r = 51.827$ ;  $\rho = 1000$  kg/m<sup>3</sup>

Phantom section: Flat Section

Measurement Standard: DASY5 (IEEE/IEC/ANSI C63.19-2011)

DASY Configuration:

- Area Scan setting - Find Secondary Maximum Within: 2.0dB and with a peak SAR value greater than 0.5 W/Kg
- Probe: EX3DV4 - SN3977; ConvF(7.37, 7.37, 7.37); Calibrated: 2014/2/17;
- Sensor-Surface: 2mm (Mechanical Surface Detection)
- Electronics: DAE4 Sn779; Calibrated: 2014/2/25
- Phantom: ELI v5.0; Type: QDOVA002AA; Serial: TP:1133
- Measurement SW: DASY52, Version 52.8 (7); SEMCAD X Version 14.6.10 (7164)

**Flat/Area Scan (81x121x1):**

Interpolated grid: dx=1.500 mm, dy=1.500 mm

Maximum value of SAR (interpolated) = 1.72 W/kg

**Flat/Zoom Scan (5x5x7)/Cube 0:**

Measurement grid: dx=8mm, dy=8mm, dz=5mm

Reference Value = 16.551 V/m; Power Drift = 0.07 dB

Peak SAR (extrapolated) = 2.06 W/kg

**SAR(1 g) = 1.21 W/kg; SAR(10 g) = 0.677 W/kg**

Maximum value of SAR (measured) = 1.66 W/kg

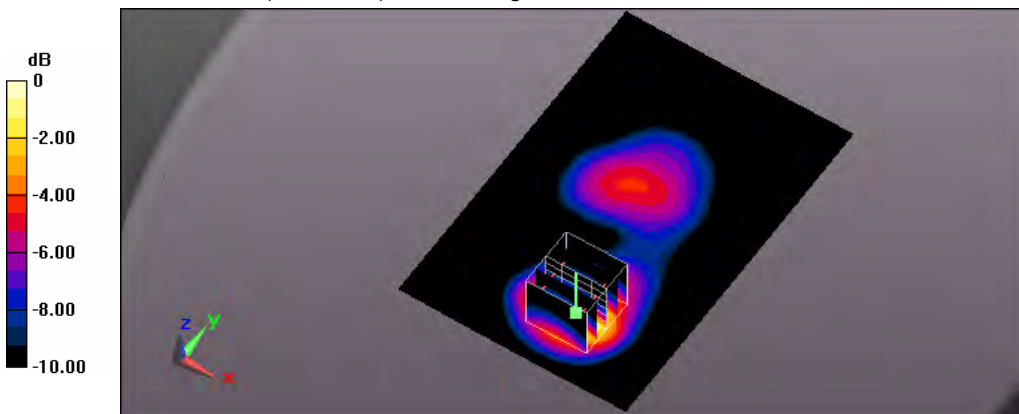

0 dB = 1.66 W/kg = 2.20 dBW/kg

Test Laboratory: A Test Lab Techno Corp.

Date: 2014/11/26 Time: PM 06:38:46

**8\_Flat\_LTE Band2 BW 20M CH18700\_QPSK with 1 RB Size 99 RB Offset side 2 surface to phantom 10mm**

**DUT: AC779S-200; Type: Mobile Hot Spot; Serial: 01426000002034**

Communication System: UID 0, Generic LTE (0); Frequency: 1860 MHz; Duty Cycle: 1:1

Medium parameters used:  $f = 1860 \text{ MHz}$ ;  $\sigma = 1.472 \text{ S/m}$ ;  $\epsilon_r = 51.827$ ;  $\rho = 1000 \text{ kg/m}^3$

Phantom section: Flat Section

Measurement Standard: DASYS (IEEE/IEC/ANSI C63.19-2011)

DASY Configuration:

- Area Scan setting - Find Secondary Maximum Within: 2.0dB and with a peak SAR value greater than 0.5 W/Kg
- Probe: EX3DV4 - SN3977; ConvF(7.37, 7.37, 7.37); Calibrated: 2014/2/17;
- Sensor-Surface: 2mm (Mechanical Surface Detection)
- Electronics: DAE4 Sn779; Calibrated: 2014/2/25
- Phantom: ELI v5.0; Type: QDOVA002AA; Serial: TP:1133
- Measurement SW: DASYS2, Version 52.8 (7); SEMCAD X Version 14.6.10 (7164)

**Flat/Area Scan (81x121x1):**

Interpolated grid:  $dx=1.500 \text{ mm}$ ,  $dy=1.500 \text{ mm}$

Maximum value of SAR (interpolated) = 1.10 W/kg

**Flat/Zoom Scan (5x5x7)/Cube 0:**

Measurement grid:  $dx=8\text{mm}$ ,  $dy=8\text{mm}$ ,  $dz=5\text{mm}$

Reference Value = 18.490 V/m; Power Drift = -0.08 dB

Peak SAR (extrapolated) = 1.32 W/kg

**SAR(1 g) = 0.802 W/kg; SAR(10 g) = 0.476 W/kg**

Maximum value of SAR (measured) = 1.05 W/kg

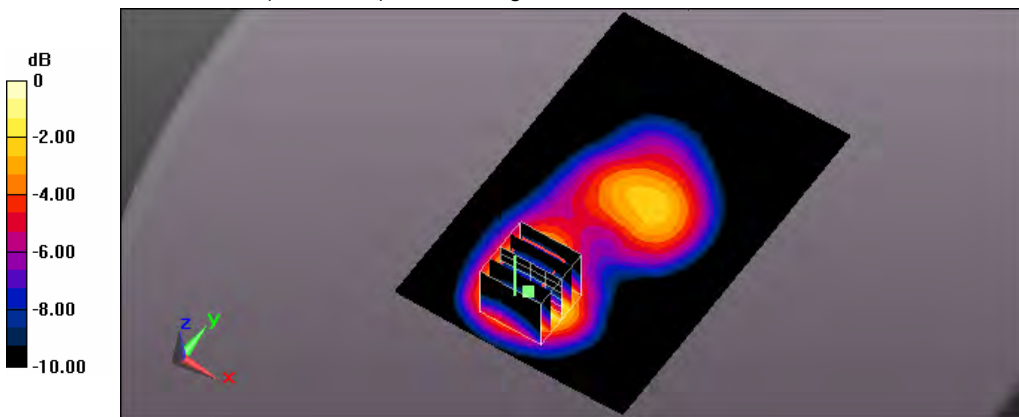

0 dB = 1.05 W/kg = 0.21 dBW/kg

Test Laboratory: A Test Lab Techno Corp.

Date: 2014/11/26 Time: PM 08:31:22

**14\_Flat\_LTE Band2 BW 20M CH18700\_QPSK with 1 RB Size 99 RB Offset side 3 surface to phantom 10mm**

**DUT: AC779S-200; Type: Mobile Hot Spot; Serial: 01426000002034**

Communication System: UID 0, Generic LTE (0); Frequency: 1860 MHz; Duty Cycle: 1:1

Medium parameters used:  $f = 1860 \text{ MHz}$ ;  $\sigma = 1.472 \text{ S/m}$ ;  $\epsilon_r = 51.827$ ;  $\rho = 1000 \text{ kg/m}^3$

Phantom section: Flat Section

Measurement Standard: DASY5 (IEEE/IEC/ANSI C63.19-2011)

DASY Configuration:

- Area Scan setting - Find Secondary Maximum Within: 2.0dB and with a peak SAR value greater than 0.5 W/Kg
- Probe: EX3DV4 - SN3977; ConvF(7.37, 7.37, 7.37); Calibrated: 2014/2/17;
- Sensor-Surface: 2mm (Mechanical Surface Detection)
- Electronics: DAE4 Sn779; Calibrated: 2014/2/25
- Phantom: ELI v5.0; Type: QDOVA002AA; Serial: TP:1133
- Measurement SW: DASY52, Version 52.8 (7); SEMCAD X Version 14.6.10 (7164)

**Flat/Area Scan (61x111x1):**

Interpolated grid:  $dx=1.500 \text{ mm}$ ,  $dy=1.500 \text{ mm}$

Maximum value of SAR (interpolated) = 0.159 W/kg

**Flat/Zoom Scan (5x5x7)/Cube 0:**

Measurement grid:  $dx=8\text{mm}$ ,  $dy=8\text{mm}$ ,  $dz=5\text{mm}$

Reference Value = 10.326 V/m; Power Drift = -0.01 dB

Peak SAR (extrapolated) = 0.186 W/kg

**SAR(1 g) = 0.119 W/kg; SAR(10 g) = 0.072 W/kg**

Maximum value of SAR (measured) = 0.154 W/kg

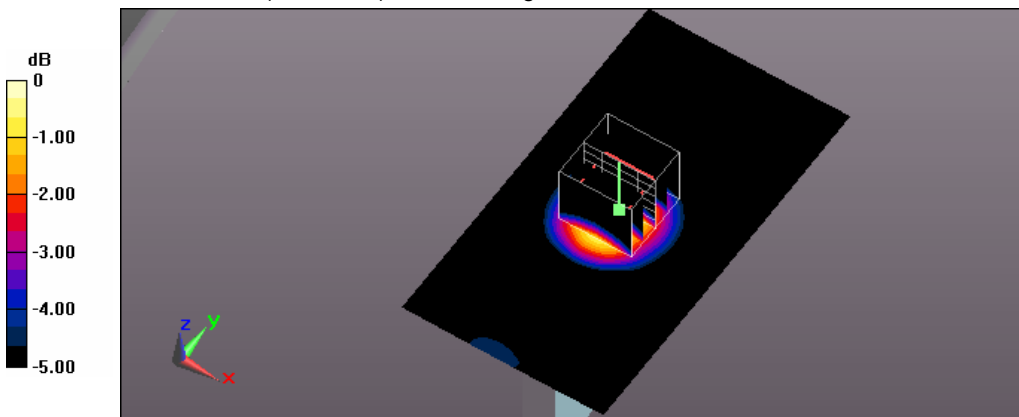

0 dB = 0.154 W/kg = -8.12 dBW/kg

Test Laboratory: A Test Lab Techno Corp.

Date: 2014/11/26 Time: PM 08:53:15

**15\_Flat\_LTE Band2 BW 20M CH18700\_QPSK with 1 RB Size 99 RB Offset side 4 surface to phantom 10mm**

**DUT: AC779S-200; Type: Mobile Hot Spot; Serial: 01426000002034**

Communication System: UID 0, Generic LTE (0); Frequency: 1860 MHz; Duty Cycle: 1:1

Medium parameters used:  $f = 1860 \text{ MHz}$ ;  $\sigma = 1.472 \text{ S/m}$ ;  $\epsilon_r = 51.827$ ;  $\rho = 1000 \text{ kg/m}^3$

Phantom section: Flat Section

Measurement Standard: DASY5 (IEEE/IEC/ANSI C63.19-2011)

DASY Configuration:

- Area Scan setting - Find Secondary Maximum Within: 2.0dB and with a peak SAR value greater than 0.5 W/Kg
- Probe: EX3DV4 - SN3977; ConvF(7.37, 7.37, 7.37); Calibrated: 2014/2/17;
- Sensor-Surface: 2mm (Mechanical Surface Detection)
- Electronics: DAE4 Sn779; Calibrated: 2014/2/25
- Phantom: ELI v5.0; Type: QDOVA002AA; Serial: TP:1133
- Measurement SW: DASY52, Version 52.8 (7); SEMCAD X Version 14.6.10 (7164)

**Flat/Area Scan (61x111x1):**

Interpolated grid:  $dx=1.500 \text{ mm}$ ,  $dy=1.500 \text{ mm}$

Maximum value of SAR (interpolated) = 0.760 W/kg

**Flat/Zoom Scan (5x5x7)/Cube 0:**

Measurement grid:  $dx=8\text{mm}$ ,  $dy=8\text{mm}$ ,  $dz=5\text{mm}$

Reference Value = 19.873 V/m; Power Drift = 0.06 dB

Peak SAR (extrapolated) = 0.893 W/kg

**SAR(1 g) = 0.557 W/kg; SAR(10 g) = 0.333 W/kg**

Maximum value of SAR (measured) = 0.737 W/kg

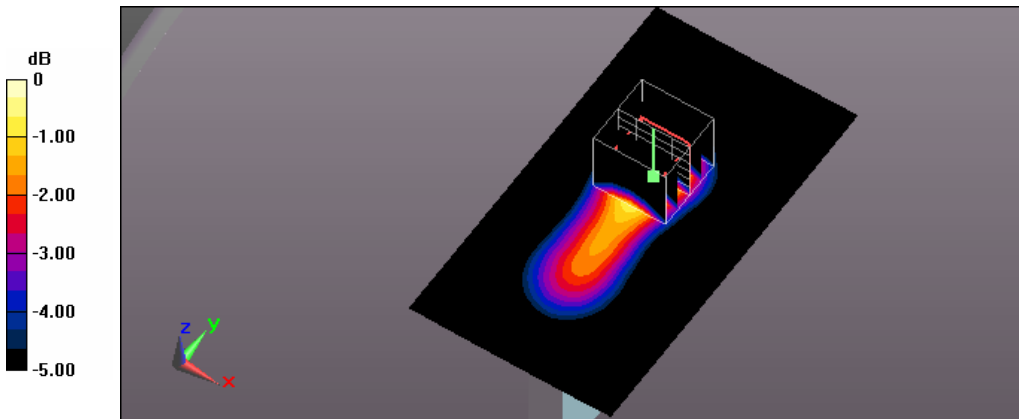

0 dB = 0.737 W/kg = -1.33 dBW/kg



Test Laboratory: A Test Lab Techno Corp.

Date: 2014/11/26 Time: PM 10:44:45

**18\_Flat\_LTE Band2 BW 20M CH18700\_QPSK with 1 RB Size 99 RB Offset side 5 surface to phantom 10mm**

**DUT: AC779S-200; Type: Mobile Hot Spot; Serial: 01426000002034**

Communication System: UID 0, Generic LTE (0); Frequency: 1860 MHz; Duty Cycle: 1:1

Medium parameters used:  $f = 1860 \text{ MHz}$ ;  $\sigma = 1.472 \text{ S/m}$ ;  $\epsilon_r = 51.827$ ;  $\rho = 1000 \text{ kg/m}^3$

Phantom section: Flat Section

Measurement Standard: DASYS (IEEE/IEC/ANSI C63.19-2011)

DASY Configuration:

- Area Scan setting - Find Secondary Maximum Within: 2.0dB and with a peak SAR value greater than 0.5 W/Kg
- Probe: EX3DV4 - SN3977; ConvF(7.37, 7.37, 7.37); Calibrated: 2014/2/17;
- Sensor-Surface: 2mm (Mechanical Surface Detection)
- Electronics: DAE4 Sn779; Calibrated: 2014/2/25
- Phantom: ELI v5.0; Type: QDOVA002AA; Serial: TP:1133
- Measurement SW: DASYS2, Version 52.8 (7); SEMCAD X Version 14.6.10 (7164)

**Flat/Area Scan (61x101x1):**

Interpolated grid:  $dx=1.500 \text{ mm}$ ,  $dy=1.500 \text{ mm}$

Maximum value of SAR (interpolated) = 1.45 W/kg

**Flat/Zoom Scan (5x5x7)/Cube 0:**

Measurement grid:  $dx=8\text{mm}$ ,  $dy=8\text{mm}$ ,  $dz=5\text{mm}$

Reference Value = 27.475 V/m; Power Drift = -0.05 dB

Peak SAR (extrapolated) = 1.78 W/kg

**SAR(1 g) = 1.06 W/kg; SAR(10 g) = 0.591 W/kg**

Maximum value of SAR (measured) = 1.41 W/kg

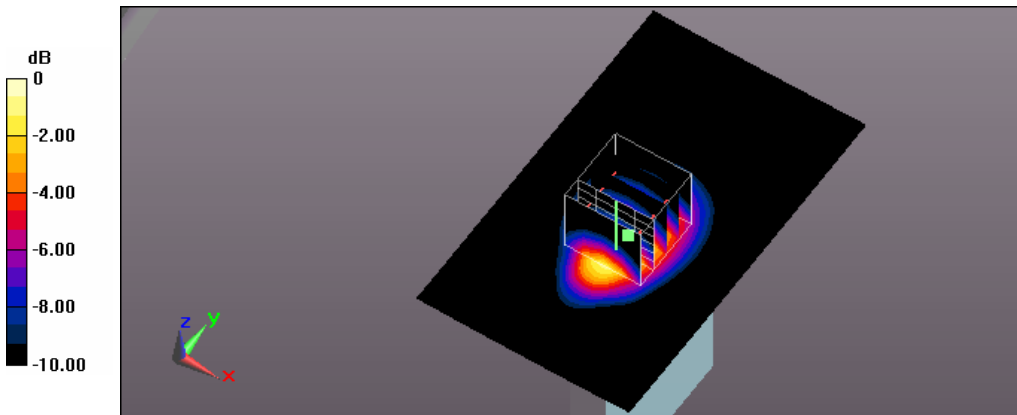

0 dB = 1.41 W/kg = 1.49 dBW/kg

Test Laboratory: A Test Lab Techno Corp.

Date: 2014/11/26 Time: PM 03:03:53

**2\_Flat\_LTE Band2 BW 20M CH18900\_QPSK with 1 RB Size 0 RB Offset side 1 surface to phantom 10mm**

**DUT: AC779S-200; Type: Mobile Hot Spot; Serial: 01426000002034**

Communication System: UID 0, Generic LTE (0); Frequency: 1880 MHz; Duty Cycle: 1:1

Medium parameters used:  $f = 1880 \text{ MHz}$ ;  $\sigma = 1.487 \text{ S/m}$ ;  $\epsilon_r = 51.76$ ;  $\rho = 1000 \text{ kg/m}^3$

Phantom section: Flat Section

Measurement Standard: DASY5 (IEEE/IEC/ANSI C63.19-2011)

DASY Configuration:

- Area Scan setting - Find Secondary Maximum Within: 2.0dB and with a peak SAR value greater than 0.5 W/Kg
- Probe: EX3DV4 - SN3977; ConvF(7.37, 7.37, 7.37); Calibrated: 2014/2/17;
- Sensor-Surface: 2mm (Mechanical Surface Detection)
- Electronics: DAE4 Sn779; Calibrated: 2014/2/25
- Phantom: ELI v5.0; Type: QDOVA002AA; Serial: TP:1133
- Measurement SW: DASY52, Version 52.8 (7); SEMCAD X Version 14.6.10 (7164)

**Flat/Area Scan (81x121x1):**

Interpolated grid:  $dx=1.500 \text{ mm}$ ,  $dy=1.500 \text{ mm}$

Maximum value of SAR (interpolated) = 1.57 W/kg

**Flat/Zoom Scan (5x5x7)/Cube 0:**

Measurement grid:  $dx=8\text{mm}$ ,  $dy=8\text{mm}$ ,  $dz=5\text{mm}$

Reference Value = 16.019 V/m; Power Drift = 0.18 dB

Peak SAR (extrapolated) = 1.93 W/kg

**SAR(1 g) = 1.15 W/kg; SAR(10 g) = 0.645 W/kg**

Maximum value of SAR (measured) = 1.57 W/kg

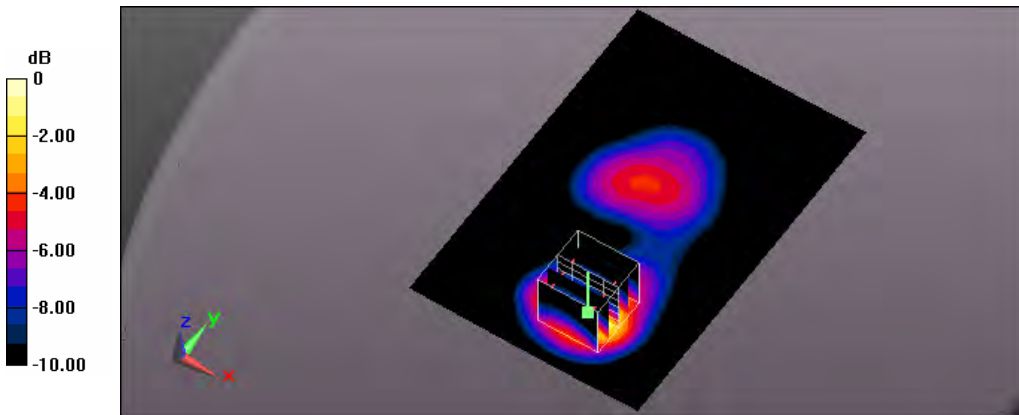

0 dB = 1.57 W/kg = 1.96 dBW/kg

Test Laboratory: A Test Lab Techno Corp.

Date: 2014/11/26 Time: PM 07:03:02

**9\_Flat\_LTE Band2 BW 20M CH18900\_QPSK with 1 RB Size 0 RB Offset side 2 surface to phantom 10mm**

**DUT: AC779S-200; Type: Mobile Hot Spot; Serial: 01426000002034**

Communication System: UID 0, Generic LTE (0); Frequency: 1880 MHz; Duty Cycle: 1:1

Medium parameters used:  $f = 1880 \text{ MHz}$ ;  $\sigma = 1.487 \text{ S/m}$ ;  $\epsilon_r = 51.76$ ;  $\rho = 1000 \text{ kg/m}^3$

Phantom section: Flat Section

Measurement Standard: DASYS (IEEE/IEC/ANSI C63.19-2011)

DASY Configuration:

- Area Scan setting - Find Secondary Maximum Within: 2.0dB and with a peak SAR value greater than 0.5 W/Kg
- Probe: EX3DV4 - SN3977; ConvF(7.37, 7.37, 7.37); Calibrated: 2014/2/17;
- Sensor-Surface: 2mm (Mechanical Surface Detection)
- Electronics: DAE4 Sn779; Calibrated: 2014/2/25
- Phantom: ELI v5.0; Type: QDOVA002AA; Serial: TP:1133
- Measurement SW: DASYS2, Version 52.8 (7); SEMCAD X Version 14.6.10 (7164)

**Flat/Area Scan (81x121x1):**

Interpolated grid:  $dx=1.500 \text{ mm}$ ,  $dy=1.500 \text{ mm}$

Maximum value of SAR (interpolated) = 1.16 W/kg

**Flat/Zoom Scan (5x5x7)/Cube 0:**

Measurement grid:  $dx=8\text{mm}$ ,  $dy=8\text{mm}$ ,  $dz=5\text{mm}$

Reference Value = 18.760 V/m; Power Drift = -0.02 dB

Peak SAR (extrapolated) = 1.38 W/kg

**SAR(1 g) = 0.834 W/kg; SAR(10 g) = 0.495 W/kg**

Maximum value of SAR (measured) = 1.08 W/kg

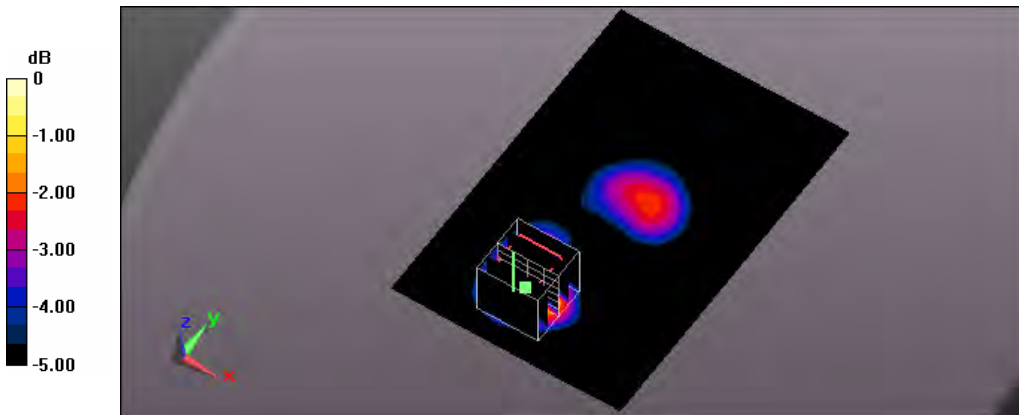

0 dB = 1.08 W/kg = 0.33 dBW/kg

Test Laboratory: A Test Lab Techno Corp.

Date: 2014/11/27 Time: AM 12:08:17

**19\_Flat\_LTE Band2 BW 20M CH18900\_QPSK with 1 RB Size 0 RB Offset side 5 surface to phantom 10mm**

**DUT: AC779S-200; Type: Mobile Hot Spot; Serial: 01426000002034**

Communication System: UID 0, Generic LTE (0); Frequency: 1880 MHz; Duty Cycle: 1:1

Medium parameters used:  $f = 1880 \text{ MHz}$ ;  $\sigma = 1.487 \text{ S/m}$ ;  $\epsilon_r = 51.76$ ;  $\rho = 1000 \text{ kg/m}^3$

Phantom section: Flat Section

Measurement Standard: DASY5 (IEEE/IEC/ANSI C63.19-2011)

DASY Configuration:

- Area Scan setting - Find Secondary Maximum Within: 2.0dB and with a peak SAR value greater than 0.5 W/Kg
- Probe: EX3DV4 - SN3977; ConvF(7.37, 7.37, 7.37); Calibrated: 2014/2/17;
- Sensor-Surface: 2mm (Mechanical Surface Detection)
- Electronics: DAE4 Sn779; Calibrated: 2014/2/25
- Phantom: ELI v5.0; Type: QDOVA002AA; Serial: TP:1133
- Measurement SW: DASY52, Version 52.8 (7); SEMCAD X Version 14.6.10 (7164)

**Flat/Area Scan (61x101x1):**

Interpolated grid:  $dx=1.500 \text{ mm}$ ,  $dy=1.500 \text{ mm}$

Maximum value of SAR (interpolated) = 1.49 W/kg

**Flat/Zoom Scan (5x5x7)/Cube 0:**

Measurement grid:  $dx=8\text{mm}$ ,  $dy=8\text{mm}$ ,  $dz=5\text{mm}$

Reference Value = 26.921 V/m; Power Drift = 0.08 dB

Peak SAR (extrapolated) = 1.84 W/kg

**SAR(1 g) = 1.1 W/kg; SAR(10 g) = 0.612 W/kg**

Maximum value of SAR (measured) = 1.49 W/kg

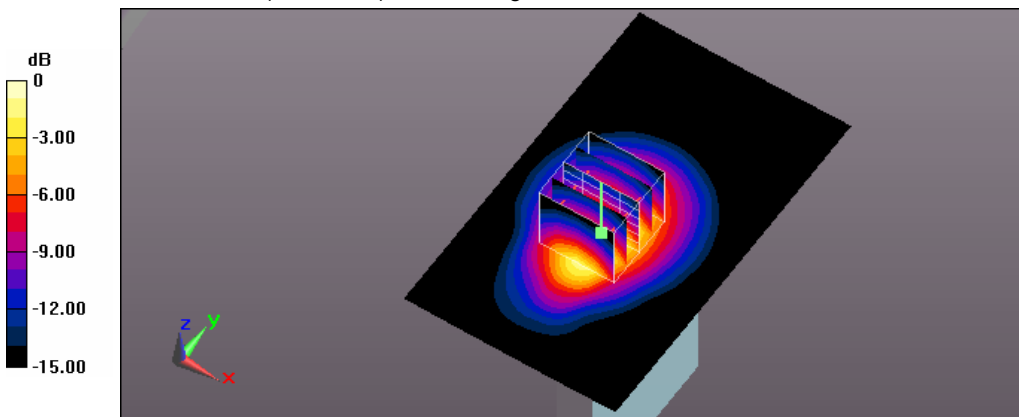

0 dB = 1.49 W/kg = 1.73 dBW/kg

Test Laboratory: A Test Lab Techno Corp.

Date: 2014/11/26 Time: PM 04:06:06

**3\_Flat\_LTE Band2 BW 20M CH19100\_QPSK with 1 RB Size 0 RB Offset side 1 surface to phantom 10mm**

**DUT: AC779S-200; Type: Mobile Hot Spot; Serial: 01426000002034**

Communication System: UID 0, Generic LTE (0); Frequency: 1900 MHz; Duty Cycle: 1:1

Medium parameters used:  $f = 1900$  MHz;  $\sigma = 1.511$  S/m;  $\epsilon_r = 51.635$ ;  $\rho = 1000$  kg/m<sup>3</sup>

Phantom section: Flat Section

Measurement Standard: DASYS (IEEE/IEC/ANSI C63.19-2011)

DASY Configuration:

- Area Scan setting - Find Secondary Maximum Within: 2.0dB and with a peak SAR value greater than 0.5 W/Kg
- Probe: EX3DV4 - SN3977; ConvF(7.37, 7.37, 7.37); Calibrated: 2014/2/17;
- Sensor-Surface: 2mm (Mechanical Surface Detection)
- Electronics: DAE4 Sn779; Calibrated: 2014/2/25
- Phantom: ELI v5.0; Type: QDOVA002AA; Serial: TP:1133
- Measurement SW: DASYS2, Version 52.8 (7); SEMCAD X Version 14.6.10 (7164)

**Flat/Area Scan (81x121x1):**

Interpolated grid: dx=1.500 mm, dy=1.500 mm

Maximum value of SAR (interpolated) = 1.41 W/kg

**Flat/Zoom Scan (5x5x7)/Cube 0:**

Measurement grid: dx=8mm, dy=8mm, dz=5mm

Reference Value = 14.985 V/m; Power Drift = 0.04 dB

Peak SAR (extrapolated) = 1.66 W/kg

**SAR(1 g) = 0.977 W/kg; SAR(10 g) = 0.550 W/kg**

Maximum value of SAR (measured) = 1.34 W/kg

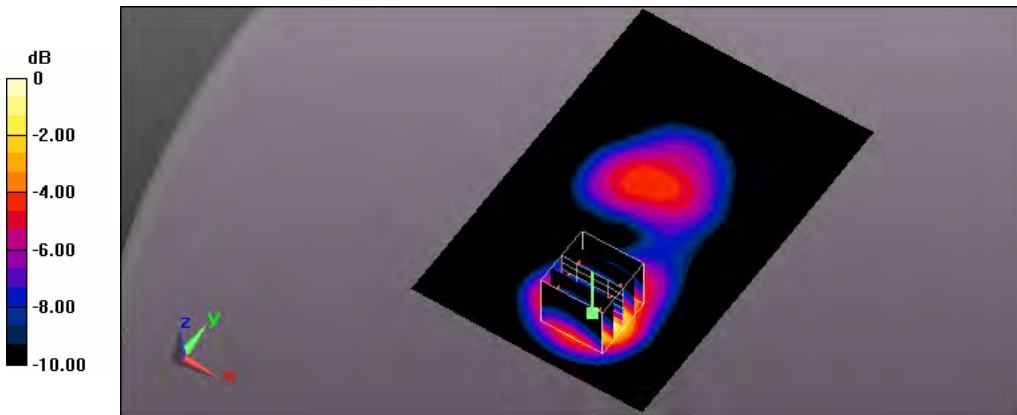

0 dB = 1.34 W/kg = 1.27 dBW/kg

Test Laboratory: A Test Lab Techno Corp.

Date: 2014/11/26 Time: PM 07:24:18

**10\_Flat\_LTE Band2 BW 20M CH19100\_QPSK with 1 RB Size 0 RB Offset side 2 surface to phantom 10mm**

**DUT: AC779S-200; Type: Mobile Hot Spot; Serial: 01426000002034**

Communication System: UID 0, Generic LTE (0); Frequency: 1900 MHz; Duty Cycle: 1:1

Medium parameters used:  $f = 1900$  MHz;  $\sigma = 1.511$  S/m;  $\epsilon_r = 51.635$ ;  $\rho = 1000$  kg/m<sup>3</sup>

Phantom section: Flat Section

Measurement Standard: DASYS (IEEE/IEC/ANSI C63.19-2011)

DASY Configuration:

- Area Scan setting - Find Secondary Maximum Within: 2.0dB and with a peak SAR value greater than 0.5 W/Kg
- Probe: EX3DV4 - SN3977; ConvF(7.37, 7.37, 7.37); Calibrated: 2014/2/17;
- Sensor-Surface: 2mm (Mechanical Surface Detection)
- Electronics: DAE4 Sn779; Calibrated: 2014/2/25
- Phantom: ELI v5.0; Type: QDOVA002AA; Serial: TP:1133
- Measurement SW: DASYS2, Version 52.8 (7); SEMCAD X Version 14.6.10 (7164)

**Flat/Area Scan (81x121x1):**

Interpolated grid: dx=1.500 mm, dy=1.500 mm

Maximum value of SAR (interpolated) = 0.991 W/kg

**Flat/Zoom Scan (5x5x7)/Cube 0:**

Measurement grid: dx=8mm, dy=8mm, dz=5mm

Reference Value = 17.245 V/m; Power Drift = 0.01 dB

Peak SAR (extrapolated) = 1.16 W/kg

**SAR(1 g) = 0.703 W/kg; SAR(10 g) = 0.420 W/kg**

Maximum value of SAR (measured) = 0.914 W/kg

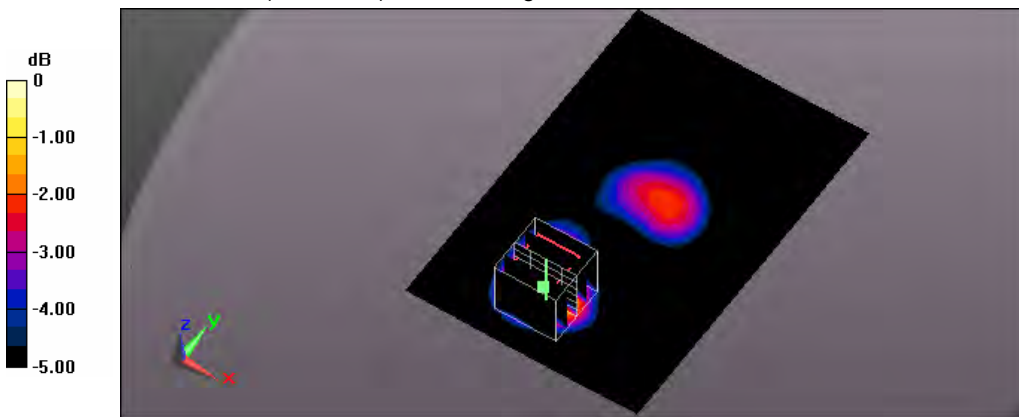

0 dB = 0.914 W/kg = -0.39 dBW/kg

Test Laboratory: A Test Lab Techno Corp.

Date: 2014/11/27 Time: AM 12:25:42

**20\_Flat\_LTE Band2 BW 20M CH19100\_QPSK with 1 RB Size 0 RB Offset side 5 surface to phantom 10mm**

**DUT: AC779S-200; Type: Mobile Hot Spot; Serial: 01426000002034**

Communication System: UID 0, Generic LTE (0); Frequency: 1900 MHz; Duty Cycle: 1:1

Medium parameters used:  $f = 1900$  MHz;  $\sigma = 1.511$  S/m;  $\epsilon_r = 51.635$ ;  $\rho = 1000$  kg/m<sup>3</sup>

Phantom section: Flat Section

Measurement Standard: DASY5 (IEEE/IEC/ANSI C63.19-2011)

DASY Configuration:

- Area Scan setting - Find Secondary Maximum Within: 2.0dB and with a peak SAR value greater than 0.5 W/Kg
- Probe: EX3DV4 - SN3977; ConvF(7.37, 7.37, 7.37); Calibrated: 2014/2/17;
- Sensor-Surface: 2mm (Mechanical Surface Detection)
- Electronics: DAE4 Sn779; Calibrated: 2014/2/25
- Phantom: ELI v5.0; Type: QDOVA002AA; Serial: TP:1133
- Measurement SW: DASY52, Version 52.8 (7); SEMCAD X Version 14.6.10 (7164)

**Flat/Area Scan (61x101x1):**

Interpolated grid: dx=1.500 mm, dy=1.500 mm

Maximum value of SAR (interpolated) = 1.27 W/kg

**Flat/Zoom Scan (5x5x7)/Cube 0:**

Measurement grid: dx=8mm, dy=8mm, dz=5mm

Reference Value = 24.811 V/m; Power Drift = 0.09 dB

Peak SAR (extrapolated) = 1.53 W/kg

**SAR(1 g) = 0.908 W/kg; SAR(10 g) = 0.503 W/kg**

Maximum value of SAR (measured) = 1.21 W/kg

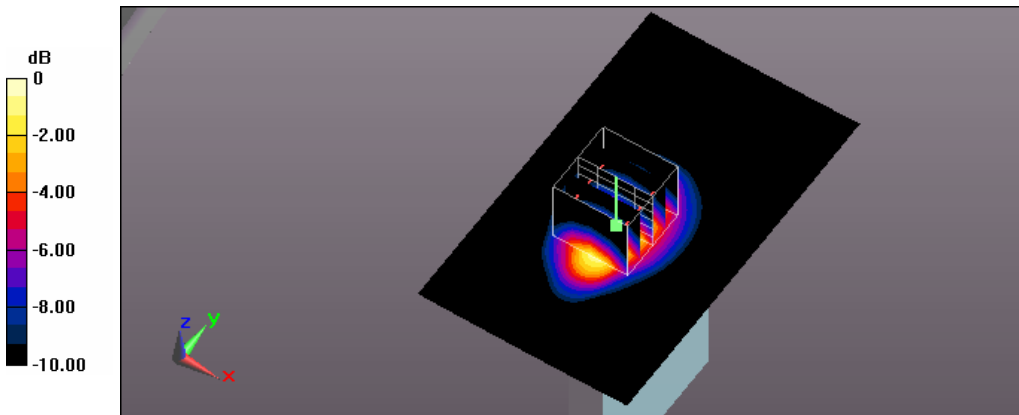

0 dB = 1.21 W/kg = 0.83 dBW/kg

Test Laboratory: A Test Lab Techno Corp.

Date: 2014/11/26 Time: PM 04:53:43

**5\_Flat\_LTE Band2 BW 20M CH18700\_QPSK with 50 RB Size 50 RB Offset side 1 surface to phantom 10mm**

**DUT: AC779S-200; Type: Mobile Hot Spot; Serial: 01426000002034**

Communication System: UID 0, Generic LTE (0); Frequency: 1860 MHz; Duty Cycle: 1:1

Medium parameters used:  $f = 1860 \text{ MHz}$ ;  $\sigma = 1.472 \text{ S/m}$ ;  $\epsilon_r = 51.827$ ;  $\rho = 1000 \text{ kg/m}^3$

Phantom section: Flat Section

Measurement Standard: DASY5 (IEEE/IEC/ANSI C63.19-2011)

DASY Configuration:

- Area Scan setting - Find Secondary Maximum Within: 2.0dB and with a peak SAR value greater than 0.5 W/Kg
- Probe: EX3DV4 - SN3977; ConvF(7.37, 7.37, 7.37); Calibrated: 2014/2/17;
- Sensor-Surface: 2mm (Mechanical Surface Detection)
- Electronics: DAE4 Sn779; Calibrated: 2014/2/25
- Phantom: ELI v5.0; Type: QDOVA002AA; Serial: TP:1133
- Measurement SW: DASY52, Version 52.8 (7); SEMCAD X Version 14.6.10 (7164)

**Flat/Area Scan (81x121x1):**

Interpolated grid:  $dx=1.500 \text{ mm}$ ,  $dy=1.500 \text{ mm}$

Maximum value of SAR (interpolated) = 1.23 W/kg

**Flat/Zoom Scan (5x5x7)/Cube 0:**

Measurement grid:  $dx=8\text{mm}$ ,  $dy=8\text{mm}$ ,  $dz=5\text{mm}$

Reference Value = 13.887 V/m; Power Drift = 0.06 dB

Peak SAR (extrapolated) = 1.46 W/kg

**SAR(1 g) = 0.854 W/kg; SAR(10 g) = 0.475 W/kg**

Maximum value of SAR (measured) = 1.17 W/kg

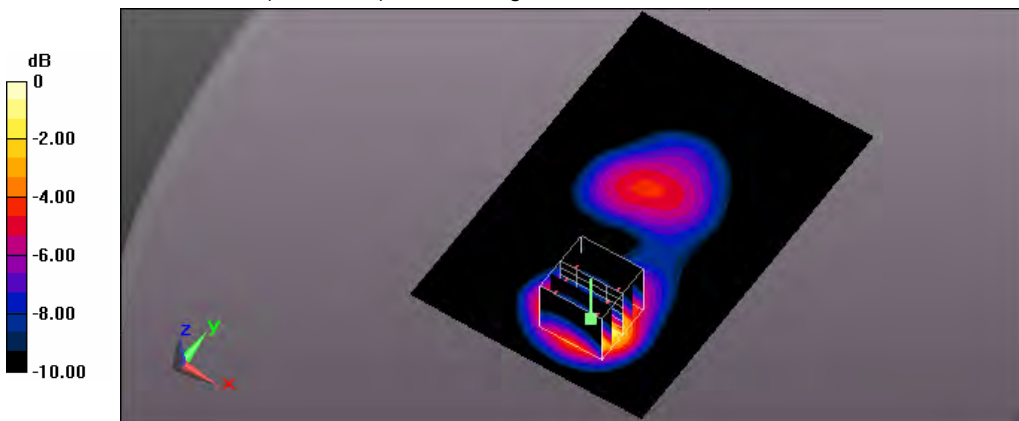

0 dB = 1.17 W/kg = 0.68 dBW/kg



Test Laboratory: A Test Lab Techno Corp.

Date: 2014/11/27 Time: AM 02:50:32

**92\_Flat\_LTE Band2 BW 20M CH18700\_QPSK with 50 RB Size 50 RB Offset side 5 surface to phantom 10mm**

**DUT: AC779S-200; Type: Mobile Hot Spot; Serial: 014260000002034**

Communication System: UID 0, Generic LTE (0); Frequency: 1860 MHz; Duty Cycle: 1:1

Medium parameters used:  $f = 1860 \text{ MHz}$ ;  $\sigma = 1.472 \text{ S/m}$ ;  $\epsilon_r = 51.827$ ;  $\rho = 1000 \text{ kg/m}^3$

Phantom section: Flat Section

Measurement Standard: DASY5 (IEEE/IEC/ANSI C63.19-2011)

DASY Configuration:

- Area Scan setting - Find Secondary Maximum Within: 2.0dB and with a peak SAR value greater than 0.5 W/Kg
- Probe: EX3DV4 - SN3977; ConvF(7.37, 7.37, 7.37); Calibrated: 2014/2/17;
- Sensor-Surface: 2mm (Mechanical Surface Detection)
- Electronics: DAE4 Sn779; Calibrated: 2014/2/25
- Phantom: ELI v5.0; Type: QDOVA002AA; Serial: TP:1133
- Measurement SW: DASY52, Version 52.8 (7); SEMCAD X Version 14.6.10 (7164)

**Flat/Area Scan (61x101x1):**

Interpolated grid:  $dx=1.500 \text{ mm}$ ,  $dy=1.500 \text{ mm}$

Maximum value of SAR (interpolated) = 1.18 W/kg

**Flat/Zoom Scan (5x5x7)/Cube 0:**

Measurement grid:  $dx=8\text{mm}$ ,  $dy=8\text{mm}$ ,  $dz=5\text{mm}$

Reference Value = 26.576 V/m; Power Drift = 0.02 dB

Peak SAR (extrapolated) = 1.36 W/kg

**SAR(1 g) = 0.822 W/kg; SAR(10 g) = 0.460 W/kg**

Maximum value of SAR (measured) = 1.11 W/kg

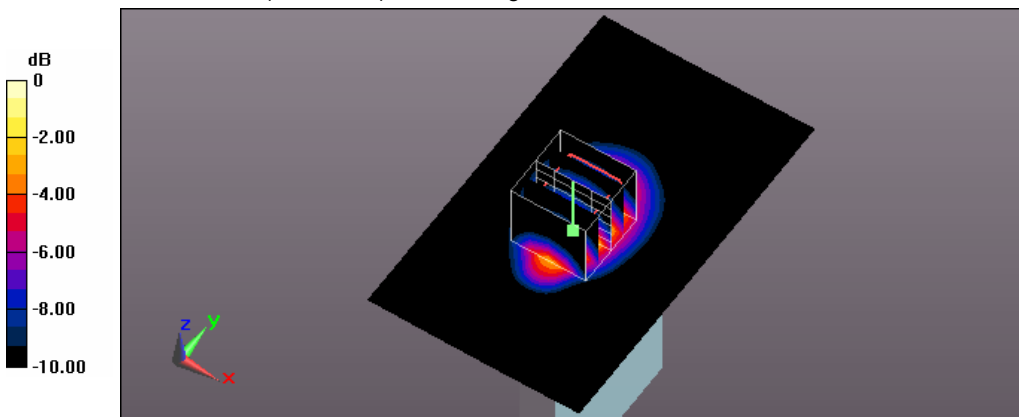

0 dB = 1.11 W/kg = 0.45 dBW/kg

Test Laboratory: A Test Lab Techno Corp.

Date: 2014/11/26 Time: PM 04:29:18

**4\_Flat\_LTE Band2 BW 20M CH18900\_QPSK with 50 RB Size 50 RB Offset side 1 surface to phantom 10mm**

**DUT: AC779S-200; Type: Mobile Hot Spot; Serial: 01426000002034**

Communication System: UID 0, Generic LTE (0); Frequency: 1880 MHz; Duty Cycle: 1:1

Medium parameters used:  $f = 1880 \text{ MHz}$ ;  $\sigma = 1.487 \text{ S/m}$ ;  $\epsilon_r = 51.76$ ;  $\rho = 1000 \text{ kg/m}^3$

Phantom section: Flat Section

Measurement Standard: DASYS (IEEE/IEC/ANSI C63.19-2011)

DASY Configuration:

- Area Scan setting - Find Secondary Maximum Within: 2.0dB and with a peak SAR value greater than 0.5 W/Kg
- Probe: EX3DV4 - SN3977; ConvF(7.37, 7.37, 7.37); Calibrated: 2014/2/17;
- Sensor-Surface: 2mm (Mechanical Surface Detection)
- Electronics: DAE4 Sn779; Calibrated: 2014/2/25
- Phantom: ELI v5.0; Type: QDOVA002AA; Serial: TP:1133
- Measurement SW: DASYS2, Version 52.8 (7); SEMCAD X Version 14.6.10 (7164)

**Flat/Area Scan (81x121x1):**

Interpolated grid:  $dx=1.500 \text{ mm}$ ,  $dy=1.500 \text{ mm}$

Maximum value of SAR (interpolated) = 1.14 W/kg

**Flat/Zoom Scan (5x5x7)/Cube 0:**

Measurement grid:  $dx=8\text{mm}$ ,  $dy=8\text{mm}$ ,  $dz=5\text{mm}$

Reference Value = 13.596 V/m; Power Drift = -0.04 dB

Peak SAR (extrapolated) = 1.34 W/kg

**SAR(1 g) = 0.788 W/kg; SAR(10 g) = 0.441 W/kg**

Maximum value of SAR (measured) = 1.08 W/kg

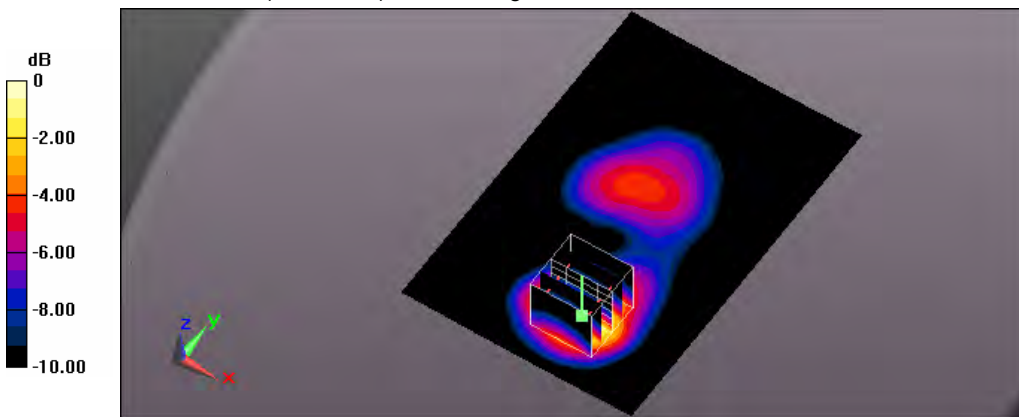

0 dB = 1.08 W/kg = 0.33 dBW/kg

Test Laboratory: A Test Lab Techno Corp.

Date: 2014/11/26 Time: PM 07:46:53

**11\_Flat\_LTE Band2 BW 20M CH18900\_QPSK with 50 RB Size 50 RB Offset side 2 surface to phantom 10mm**

**DUT: AC779S-200; Type: Mobile Hot Spot; Serial: 01426000002034**

Communication System: UID 0, Generic LTE (0); Frequency: 1880 MHz; Duty Cycle: 1:1

Medium parameters used:  $f = 1880 \text{ MHz}$ ;  $\sigma = 1.487 \text{ S/m}$ ;  $\epsilon_r = 51.76$ ;  $\rho = 1000 \text{ kg/m}^3$

Phantom section: Flat Section

Measurement Standard: DASY5 (IEEE/IEC/ANSI C63.19-2011)

DASY Configuration:

- Area Scan setting - Find Secondary Maximum Within: 2.0dB and with a peak SAR value greater than 0.5 W/Kg
- Probe: EX3DV4 - SN3977; ConvF(7.37, 7.37, 7.37); Calibrated: 2014/2/17;
- Sensor-Surface: 2mm (Mechanical Surface Detection)
- Electronics: DAE4 Sn779; Calibrated: 2014/2/25
- Phantom: ELI v5.0; Type: QDOVA002AA; Serial: TP:1133
- Measurement SW: DASY52, Version 52.8 (7); SEMCAD X Version 14.6.10 (7164)

**Flat/Area Scan (81x121x1):**

Interpolated grid:  $dx=1.500 \text{ mm}$ ,  $dy=1.500 \text{ mm}$

Maximum value of SAR (interpolated) = 0.791 W/kg

**Flat/Zoom Scan (5x5x7)/Cube 0:**

Measurement grid:  $dx=8\text{mm}$ ,  $dy=8\text{mm}$ ,  $dz=5\text{mm}$

Reference Value = 15.520 V/m; Power Drift = 0.03 dB

Peak SAR (extrapolated) = 0.905 W/kg

**SAR(1 g) = 0.549 W/kg; SAR(10 g) = 0.328 W/kg**

Maximum value of SAR (measured) = 0.714 W/kg

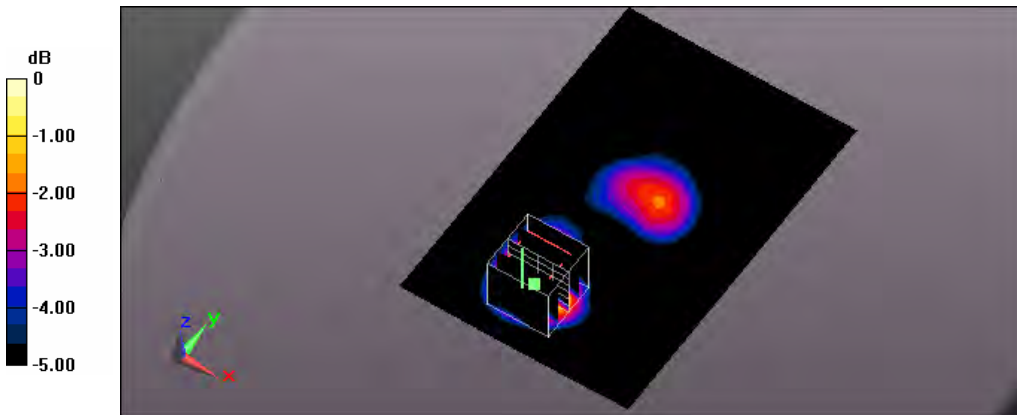

0 dB = 0.714 W/kg = -1.46 dBW/kg

Test Laboratory: A Test Lab Techno Corp.

Date: 2014/11/26 Time: PM 08:13:18

**13\_Flat\_LTE Band2 BW 20M CH18900\_QPSK with 50 RB Size 50 RB Offset side 3 surface to phantom 10mm**

**DUT: AC779S-200; Type: Mobile Hot Spot; Serial: 014260000002034**

Communication System: UID 0, Generic LTE (0); Frequency: 1880 MHz; Duty Cycle: 1:1

Medium parameters used:  $f = 1880 \text{ MHz}$ ;  $\sigma = 1.487 \text{ S/m}$ ;  $\epsilon_r = 51.76$ ;  $\rho = 1000 \text{ kg/m}^3$

Phantom section: Flat Section

Measurement Standard: DASYS (IEEE/IEC/ANSI C63.19-2011)

DASY Configuration:

- Area Scan setting - Find Secondary Maximum Within: 2.0dB and with a peak SAR value greater than 0.5 W/Kg
- Probe: EX3DV4 - SN3977; ConvF(7.37, 7.37, 7.37); Calibrated: 2014/2/17;
- Sensor-Surface: 2mm (Mechanical Surface Detection)
- Electronics: DAE4 Sn779; Calibrated: 2014/2/25
- Phantom: ELI v5.0; Type: QDOVA002AA; Serial: TP:1133
- Measurement SW: DASYS2, Version 52.8 (7); SEMCAD X Version 14.6.10 (7164)

**Flat/Area Scan (61x111x1):**

Interpolated grid:  $dx=1.500 \text{ mm}$ ,  $dy=1.500 \text{ mm}$

Maximum value of SAR (interpolated) = 0.116 W/kg

**Flat/Zoom Scan (5x5x7)/Cube 0:**

Measurement grid:  $dx=8\text{mm}$ ,  $dy=8\text{mm}$ ,  $dz=5\text{mm}$

Reference Value = 8.720 V/m; Power Drift = -0.04 dB

Peak SAR (extrapolated) = 0.135 W/kg

**SAR(1 g) = 0.086 W/kg; SAR(10 g) = 0.052 W/kg**

Maximum value of SAR (measured) = 0.111 W/kg

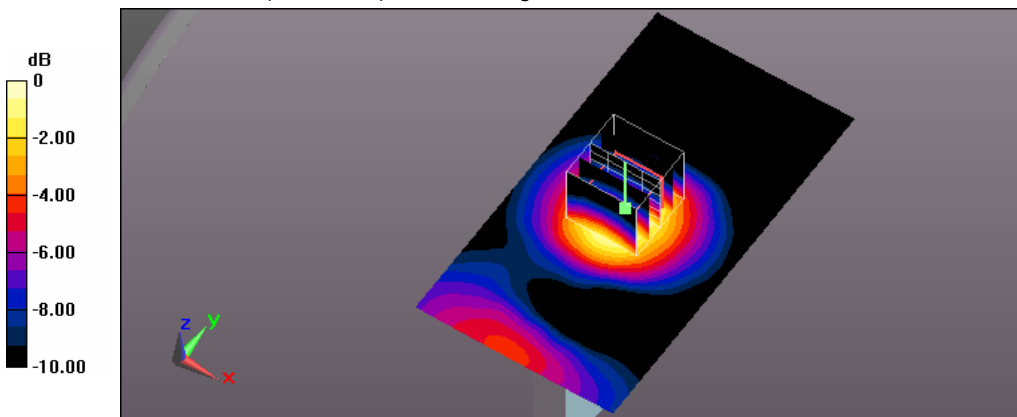

0 dB = 0.111 W/kg = -9.55 dBW/kg

Test Laboratory: A Test Lab Techno Corp.

Date: 2014/11/26 Time: PM 09:10:58

**16\_Flat\_LTE Band2 BW 20M CH18900\_QPSK with 50 RB Size 50 RB Offset side 4 surface to phantom 10mm**

**DUT: AC779S-200; Type: Mobile Hot Spot; Serial: 01426000002034**

Communication System: UID 0, Generic LTE (0); Frequency: 1880 MHz; Duty Cycle: 1:1

Medium parameters used:  $f = 1880 \text{ MHz}$ ;  $\sigma = 1.487 \text{ S/m}$ ;  $\epsilon_r = 51.76$ ;  $\rho = 1000 \text{ kg/m}^3$

Phantom section: Flat Section

Measurement Standard: DASY5 (IEEE/IEC/ANSI C63.19-2011)

DASY Configuration:

- Area Scan setting - Find Secondary Maximum Within: 2.0dB and with a peak SAR value greater than 0.5 W/Kg
- Probe: EX3DV4 - SN3977; ConvF(7.37, 7.37, 7.37); Calibrated: 2014/2/17;
- Sensor-Surface: 2mm (Mechanical Surface Detection)
- Electronics: DAE4 Sn779; Calibrated: 2014/2/25
- Phantom: ELI v5.0; Type: QDOVA002AA; Serial: TP:1133
- Measurement SW: DASY52, Version 52.8 (7); SEMCAD X Version 14.6.10 (7164)

**Flat/Area Scan (61x111x1):**

Interpolated grid:  $dx=1.500 \text{ mm}$ ,  $dy=1.500 \text{ mm}$

Maximum value of SAR (interpolated) = 0.555 W/kg

**Flat/Zoom Scan (5x5x7)/Cube 0:**

Measurement grid:  $dx=8\text{mm}$ ,  $dy=8\text{mm}$ ,  $dz=5\text{mm}$

Reference Value = 16.597 V/m; Power Drift = 0.05 dB

Peak SAR (extrapolated) = 0.651 W/kg

**SAR(1 g) = 0.404 W/kg; SAR(10 g) = 0.240 W/kg**

Maximum value of SAR (measured) = 0.534 W/kg

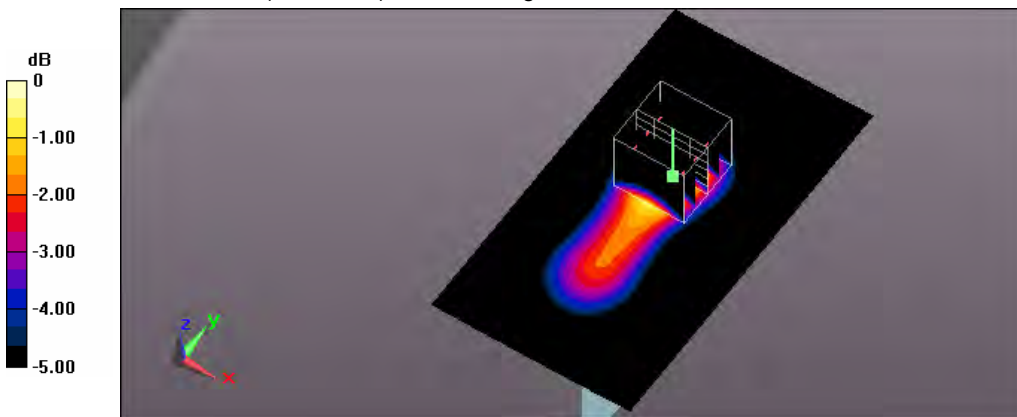

0 dB = 0.534 W/kg = -2.72 dBW/kg

Test Laboratory: A Test Lab Techno Corp.

Date: 2014/11/26 Time: PM 10:01:31

**17\_Flat\_LTE Band2 BW 20M CH18900\_QPSK with 50 RB Size 50 RB Offset side 5 surface to phantom 10mm**

**DUT: AC779S-200; Type: Mobile Hot Spot; Serial: 01426000002034**

Communication System: UID 0, Generic LTE (0); Frequency: 1880 MHz; Duty Cycle: 1:1

Medium parameters used:  $f = 1880 \text{ MHz}$ ;  $\sigma = 1.487 \text{ S/m}$ ;  $\epsilon_r = 51.76$ ;  $\rho = 1000 \text{ kg/m}^3$

Phantom section: Flat Section

Measurement Standard: DASYS (IEEE/IEC/ANSI C63.19-2011)

DASY Configuration:

- Area Scan setting - Find Secondary Maximum Within: 2.0dB and with a peak SAR value greater than 0.5 W/Kg
- Probe: EX3DV4 - SN3977; ConvF(7.37, 7.37, 7.37); Calibrated: 2014/2/17;
- Sensor-Surface: 2mm (Mechanical Surface Detection)
- Electronics: DAE4 Sn779; Calibrated: 2014/2/25
- Phantom: ELI v5.0; Type: QDOVA002AA; Serial: TP:1133
- Measurement SW: DASYS2, Version 52.8 (7); SEMCAD X Version 14.6.10 (7164)

**Flat/Area Scan (61x101x1):**

Interpolated grid:  $dx=1.500 \text{ mm}$ ,  $dy=1.500 \text{ mm}$

Maximum value of SAR (interpolated) = 1.01 W/kg

**Flat/Zoom Scan (5x5x7)/Cube 0:**

Measurement grid:  $dx=8\text{mm}$ ,  $dy=8\text{mm}$ ,  $dz=5\text{mm}$

Reference Value = 22.960 V/m; Power Drift = 0.05 dB

Peak SAR (extrapolated) = 1.22 W/kg

**SAR(1 g) = 0.722 W/kg; SAR(10 g) = 0.399 W/kg**

Maximum value of SAR (measured) = 0.976 W/kg

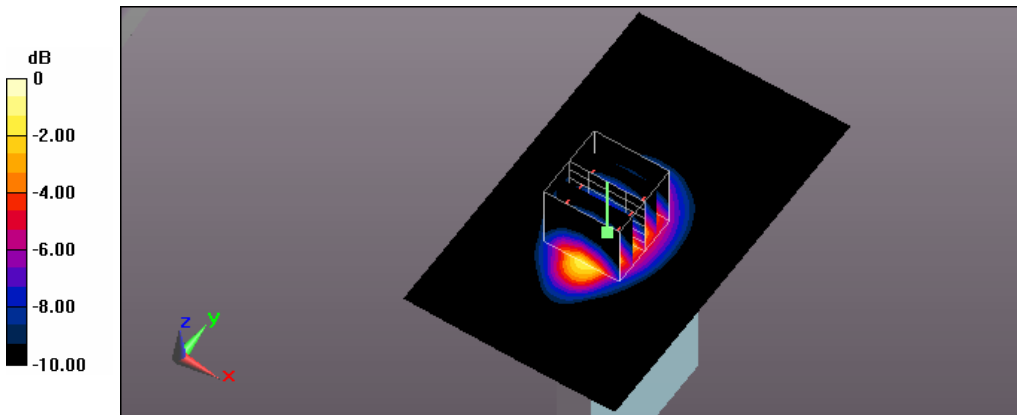

0 dB = 0.976 W/kg = -0.11 dBW/kg

Test Laboratory: A Test Lab Techno Corp.

Date: 2014/11/26 Time: PM 05:18:48

**6\_Flat\_LTE Band2 BW 20M CH19100\_QPSK with 50 RB Size 0 RB Offset side 1 surface to phantom 10mm**

**DUT: AC779S-200; Type: Mobile Hot Spot; Serial: 01426000002034**

Communication System: UID 0, Generic LTE (0); Frequency: 1900 MHz; Duty Cycle: 1:1

Medium parameters used:  $f = 1900$  MHz;  $\sigma = 1.511$  S/m;  $\epsilon_r = 51.635$ ;  $\rho = 1000$  kg/m<sup>3</sup>

Phantom section: Flat Section

Measurement Standard: DASYS (IEEE/IEC/ANSI C63.19-2011)

DASY Configuration:

- Area Scan setting - Find Secondary Maximum Within: 2.0dB and with a peak SAR value greater than 0.5 W/Kg
- Probe: EX3DV4 - SN3977; ConvF(7.37, 7.37, 7.37); Calibrated: 2014/2/17;
- Sensor-Surface: 2mm (Mechanical Surface Detection)
- Electronics: DAE4 Sn779; Calibrated: 2014/2/25
- Phantom: ELI v5.0; Type: QDOVA002AA; Serial: TP:1133
- Measurement SW: DASYS2, Version 52.8 (7); SEMCAD X Version 14.6.10 (7164)

**Flat/Area Scan (81x121x1):**

Interpolated grid: dx=1.500 mm, dy=1.500 mm

Maximum value of SAR (interpolated) = 1.00 W/kg

**Flat/Zoom Scan (5x5x7)/Cube 0:**

Measurement grid: dx=8mm, dy=8mm, dz=5mm

Reference Value = 12.754 V/m; Power Drift = -0.03 dB

Peak SAR (extrapolated) = 1.21 W/kg

**SAR(1 g) = 0.703 W/kg; SAR(10 g) = 0.393 W/kg**

Maximum value of SAR (measured) = 0.970 W/kg

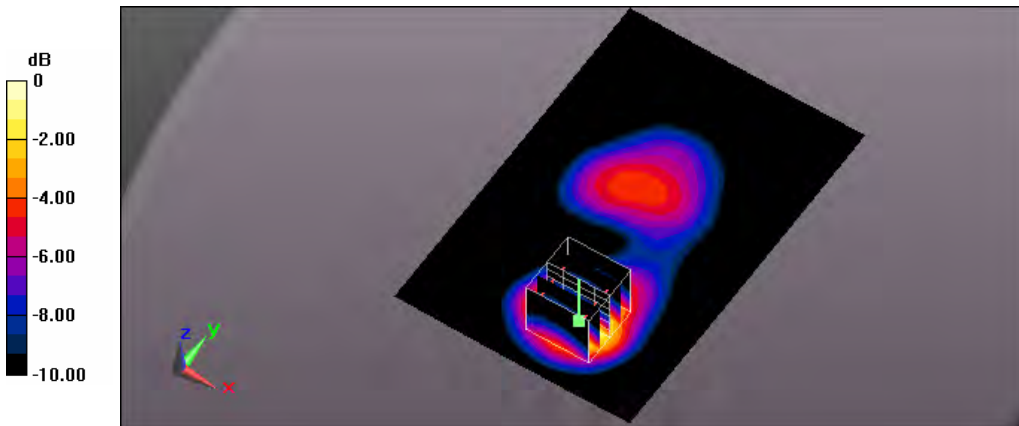

0 dB = 0.970 W/kg = -0.13 dBW/kg

Test Laboratory: A Test Lab Techno Corp.

Date: 2014/11/27 Time: AM 03:28:00

**93\_Flat\_LTE Band2 BW 20M CH19100\_QPSK with 50 RB Size 0 RB Offset side 5 surface to phantom 10mm**

**DUT: AC779S-200; Type: Mobile Hot Spot; Serial: 01426000002034**

Communication System: UID 0, Generic LTE (0); Frequency: 1900 MHz; Duty Cycle: 1:1

Medium parameters used:  $f = 1900$  MHz;  $\sigma = 1.511$  S/m;  $\epsilon_r = 51.635$ ;  $\rho = 1000$  kg/m<sup>3</sup>

Phantom section: Flat Section

Measurement Standard: DASY5 (IEEE/IEC/ANSI C63.19-2011)

DASY Configuration:

- Area Scan setting - Find Secondary Maximum Within: 2.0dB and with a peak SAR value greater than 0.5 W/Kg
- Probe: EX3DV4 - SN3977; ConvF(7.37, 7.37, 7.37); Calibrated: 2014/2/17;
- Sensor-Surface: 2mm (Mechanical Surface Detection)
- Electronics: DAE4 Sn779; Calibrated: 2014/2/25
- Phantom: ELI v5.0; Type: QDOVA002AA; Serial: TP:1133
- Measurement SW: DASY52, Version 52.8 (7); SEMCAD X Version 14.6.10 (7164)

**Flat/Area Scan (61x101x1):**

Interpolated grid: dx=1.500 mm, dy=1.500 mm

Maximum value of SAR (interpolated) = 0.946 W/kg

**Flat/Zoom Scan (5x5x7)/Cube 0:**

Measurement grid: dx=8mm, dy=8mm, dz=5mm

Reference Value = 23.815 V/m; Power Drift = -0.01 dB

Peak SAR (extrapolated) = 1.10 W/kg

**SAR(1 g) = 0.660 W/kg; SAR(10 g) = 0.367 W/kg**

Maximum value of SAR (measured) = 0.890 W/kg

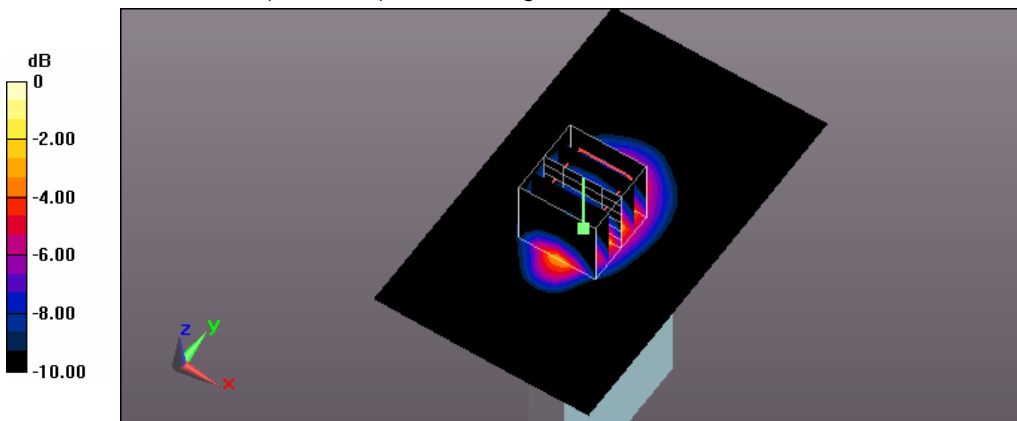

0 dB = 0.890 W/kg = -0.51 dBW/kg



Test Laboratory: A Test Lab Techno Corp.

Date: 2014/11/26 Time: PM 05:41:33

**7\_Flat\_LTE Band2 BW 20M CH18900\_QPSK with 100 RB Size 0 RB Offset side 1 surface to phantom 10mm**

**DUT: AC779S-200; Type: Mobile Hot Spot; Serial: 01426000002034**

Communication System: UID 0, Generic LTE (0); Frequency: 1880 MHz; Duty Cycle: 1:1

Medium parameters used:  $f = 1880 \text{ MHz}$ ;  $\sigma = 1.487 \text{ S/m}$ ;  $\epsilon_r = 51.76$ ;  $\rho = 1000 \text{ kg/m}^3$

Phantom section: Flat Section

Measurement Standard: DASY5 (IEEE/IEC/ANSI C63.19-2011)

DASY Configuration:

- Area Scan setting - Find Secondary Maximum Within: 2.0dB and with a peak SAR value greater than 0.5 W/Kg
- Probe: EX3DV4 - SN3977; ConvF(7.37, 7.37, 7.37); Calibrated: 2014/2/17;
- Sensor-Surface: 2mm (Mechanical Surface Detection)
- Electronics: DAE4 Sn779; Calibrated: 2014/2/25
- Phantom: ELI v5.0; Type: QDOVA002AA; Serial: TP:1133
- Measurement SW: DASY52, Version 52.8 (7); SEMCAD X Version 14.6.10 (7164)

**Flat/Area Scan (81x121x1):**

Interpolated grid:  $dx=1.500 \text{ mm}$ ,  $dy=1.500 \text{ mm}$

Maximum value of SAR (interpolated) = 1.16 W/kg

**Flat/Zoom Scan (5x5x7)/Cube 0:**

Measurement grid:  $dx=8\text{mm}$ ,  $dy=8\text{mm}$ ,  $dz=5\text{mm}$

Reference Value = 13.387 V/m; Power Drift = 0.06 dB

Peak SAR (extrapolated) = 1.39 W/kg

**SAR(1 g) = 0.821 W/kg; SAR(10 g) = 0.456 W/kg**

Maximum value of SAR (measured) = 1.12 W/kg

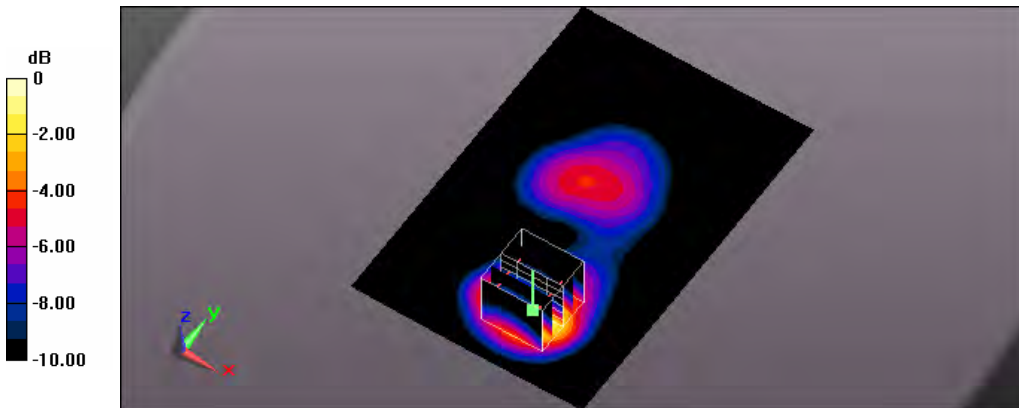

0 dB = 1.12 W/kg = 0.49 dBW/kg

Test Laboratory: A Test Lab Techno Corp.

Date: 2014/11/26 Time: PM 09:30:04

**12\_Flat\_LTE Band2 BW 20M CH18900\_QPSK with 100 RB Size 0 RB Offset side 2 surface to phantom 10mm**

**DUT: AC779S-200; Type: Mobile Hot Spot; Serial: 01426000002034**

Communication System: UID 0, Generic LTE (0); Frequency: 1880 MHz; Duty Cycle: 1:1

Medium parameters used:  $f = 1880$  MHz;  $\sigma = 1.487$  S/m;  $\epsilon_r = 51.76$ ;  $\rho = 1000$  kg/m<sup>3</sup>

Phantom section: Flat Section

Measurement Standard: DASYS (IEEE/IEC/ANSI C63.19-2011)

DASY Configuration:

- Area Scan setting - Find Secondary Maximum Within: 2.0dB and with a peak SAR value greater than 0.5 W/Kg
- Probe: EX3DV4 - SN3977; ConvF(7.37, 7.37, 7.37); Calibrated: 2014/2/17;
- Sensor-Surface: 2mm (Mechanical Surface Detection)
- Electronics: DAE4 Sn779; Calibrated: 2014/2/25
- Phantom: ELI v5.0; Type: QDOVA002AA; Serial: TP:1133
- Measurement SW: DASYS2, Version 52.8 (7); SEMCAD X Version 14.6.10 (7164)

**Flat/Area Scan (81x121x1):**

Interpolated grid: dx=1.500 mm, dy=1.500 mm

Maximum value of SAR (interpolated) = 0.852 W/kg

**Flat/Zoom Scan (5x5x7)/Cube 0:**

Measurement grid: dx=8mm, dy=8mm, dz=5mm

Reference Value = 15.313 V/m; Power Drift = -0.03 dB

Peak SAR (extrapolated) = 0.992 W/kg

**SAR(1 g) = 0.594 W/kg; SAR(10 g) = 0.351 W/kg**

Maximum value of SAR (measured) = 0.771 W/kg

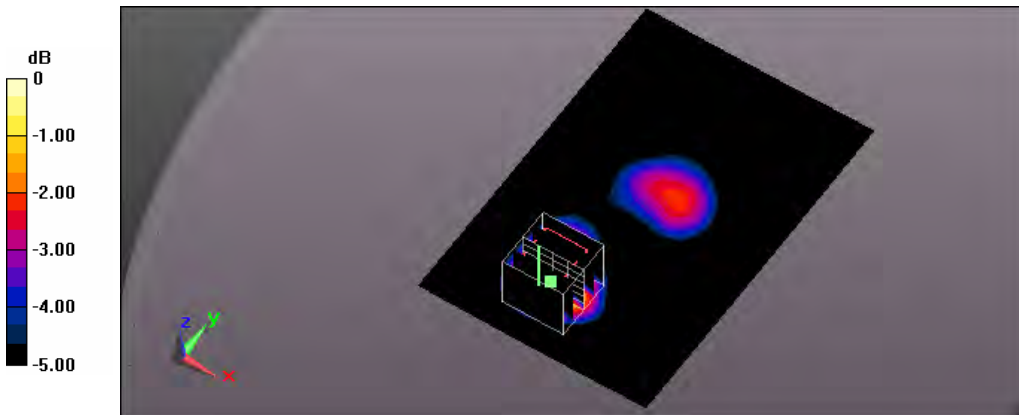

0 dB = 0.771 W/kg = -1.13 dBW/kg

Test Laboratory: A Test Lab Techno Corp.

Date: 2014/11/27 Time: AM 12:50:09

**21\_Flat\_LTE Band2 BW 20M CH18900\_QPSK with 100 RB Size 0 RB Offset side 5 surface to phantom 10mm**

**DUT: AC779S-200; Type: Mobile Hot Spot; Serial: 01426000002034**

Communication System: UID 0, Generic LTE (0); Frequency: 1880 MHz; Duty Cycle: 1:1

Medium parameters used:  $f = 1880 \text{ MHz}$ ;  $\sigma = 1.487 \text{ S/m}$ ;  $\epsilon_r = 51.76$ ;  $\rho = 1000 \text{ kg/m}^3$

Phantom section: Flat Section

Measurement Standard: DASYS (IEEE/IEC/ANSI C63.19-2011)

DASY Configuration:

- Area Scan setting - Find Secondary Maximum Within: 2.0dB and with a peak SAR value greater than 0.5 W/Kg
- Probe: EX3DV4 - SN3977; ConvF(7.37, 7.37, 7.37); Calibrated: 2014/2/17;
- Sensor-Surface: 2mm (Mechanical Surface Detection)
- Electronics: DAE4 Sn779; Calibrated: 2014/2/25
- Phantom: ELI v5.0; Type: QDOVA002AA; Serial: TP:1133
- Measurement SW: DASYS2, Version 52.8 (7); SEMCAD X Version 14.6.10 (7164)

**Flat/Area Scan (61x101x1):**

Interpolated grid:  $dx=1.500 \text{ mm}$ ,  $dy=1.500 \text{ mm}$

Maximum value of SAR (interpolated) = 1.04 W/kg

**Flat/Zoom Scan (5x5x7)/Cube 0:**

Measurement grid:  $dx=8\text{mm}$ ,  $dy=8\text{mm}$ ,  $dz=5\text{mm}$

Reference Value = 22.620 V/m; Power Drift = 0.06 dB

Peak SAR (extrapolated) = 1.23 W/kg

**SAR(1 g) = 0.739 W/kg; SAR(10 g) = 0.409 W/kg**

Maximum value of SAR (measured) = 0.995 W/kg

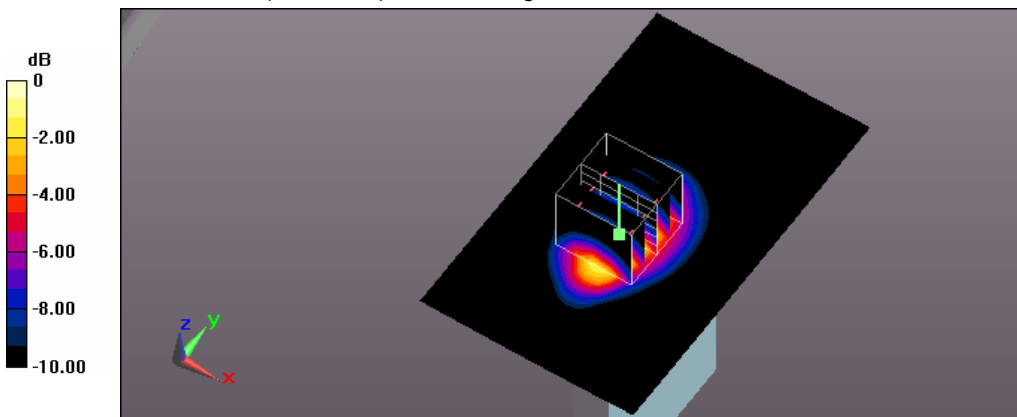

0 dB = 0.995 W/kg = -0.02 dBW/kg

Test Laboratory: A Test Lab Techno Corp.

Date: 2014/11/27 Time: PM 06:14:19

**34\_Flat\_LTE Band4 BW 20M CH20050\_QPSK with 1 RB Size 49 RB Offset side 1 surface to phantom 10mm**

**DUT: AC779S-200; Type: Mobile Hot Spot; Serial: 01426000002034**

Communication System: UID 0, Generic LTE (0); Frequency: 1720 MHz; Duty Cycle: 1:1

Medium parameters used:  $f = 1720 \text{ MHz}$ ;  $\sigma = 1.509 \text{ S/m}$ ;  $\epsilon_r = 54.329$ ;  $\rho = 1000 \text{ kg/m}^3$

Phantom section: Flat Section

Measurement Standard: DASY5 (IEEE/IEC/ANSI C63.19-2011)

DASY Configuration:

- Area Scan setting - Find Secondary Maximum Within: 2.0dB and with a peak SAR value greater than 0.5 W/Kg
- Probe: EX3DV4 - SN3977; ConvF(7.69, 7.69, 7.69); Calibrated: 2014/2/17;
- Sensor-Surface: 2mm (Mechanical Surface Detection)
- Electronics: DAE4 Sn779; Calibrated: 2014/2/25
- Phantom: ELI v5.0; Type: QDOVA002AA; Serial: TP:1133
- Measurement SW: DASY52, Version 52.8 (7); SEMCAD X Version 14.6.10 (7164)

**Flat/Area Scan (81x121x1):**

Interpolated grid:  $dx=1.500 \text{ mm}$ ,  $dy=1.500 \text{ mm}$

Maximum value of SAR (interpolated) = 1.64 W/kg

**Flat/Zoom Scan (5x5x7)/Cube 0:**

Measurement grid:  $dx=8\text{mm}$ ,  $dy=8\text{mm}$ ,  $dz=5\text{mm}$

Reference Value = 13.096 V/m; Power Drift = 0.04 dB

Peak SAR (extrapolated) = 2.08 W/kg

**SAR(1 g) = 1.21 W/kg; SAR(10 g) = 0.643 W/kg**

Maximum value of SAR (measured) = 1.68 W/kg

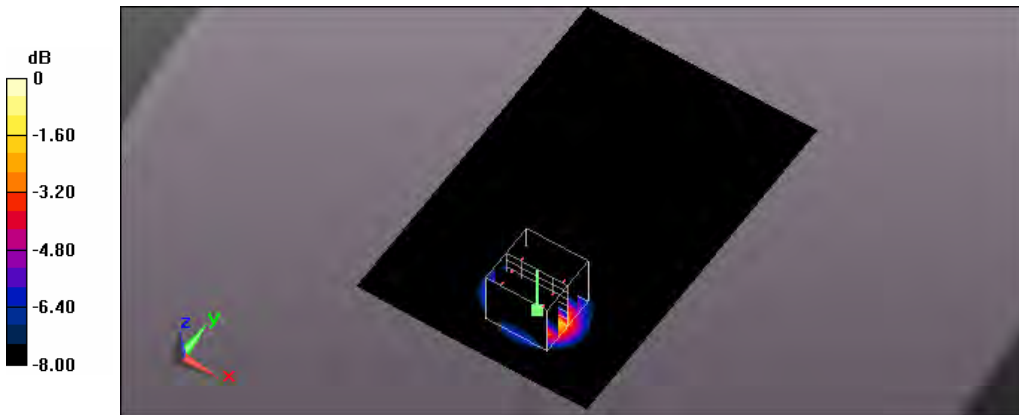

0 dB = 1.68 W/kg = 2.25 dBW/kg

Test Laboratory: A Test Lab Techno Corp.

Date: 2014/11/27 Time: PM 10:06:51

**42\_Flat\_LTE Band4 BW 20M CH20050\_QPSK with 1 RB Size 49 RB Offset side 2 surface to phantom 10mm**

**DUT: AC779S-200; Type: Mobile Hot Spot; Serial: 01426000002034**

Communication System: UID 0, Generic LTE (0); Frequency: 1720 MHz; Duty Cycle: 1:1

Medium parameters used:  $f = 1720 \text{ MHz}$ ;  $\sigma = 1.509 \text{ S/m}$ ;  $\epsilon_r = 54.329$ ;  $\rho = 1000 \text{ kg/m}^3$

Phantom section: Flat Section

Measurement Standard: DASYS (IEEE/IEC/ANSI C63.19-2011)

DASY Configuration:

- Area Scan setting - Find Secondary Maximum Within: 2.0dB and with a peak SAR value greater than 0.5 W/Kg
- Probe: EX3DV4 - SN3977; ConvF(7.69, 7.69, 7.69); Calibrated: 2014/2/17;
- Sensor-Surface: 2mm (Mechanical Surface Detection)
- Electronics: DAE4 Sn779; Calibrated: 2014/2/25
- Phantom: ELI v5.0; Type: QDOVA002AA; Serial: TP:1133
- Measurement SW: DASYS2, Version 52.8 (7); SEMCAD X Version 14.6.10 (7164)

**Flat/Area Scan (81x121x1):**

Interpolated grid:  $dx=1.500 \text{ mm}$ ,  $dy=1.500 \text{ mm}$

Maximum value of SAR (interpolated) = 0.859 W/kg

**Flat/Zoom Scan (5x5x7)/Cube 0:**

Measurement grid:  $dx=8\text{mm}$ ,  $dy=8\text{mm}$ ,  $dz=5\text{mm}$

Reference Value = 15.995 V/m; Power Drift = 0.03 dB

Peak SAR (extrapolated) = 1.06 W/kg

**SAR(1 g) = 0.643 W/kg; SAR(10 g) = 0.363 W/kg**

Maximum value of SAR (measured) = 0.820 W/kg

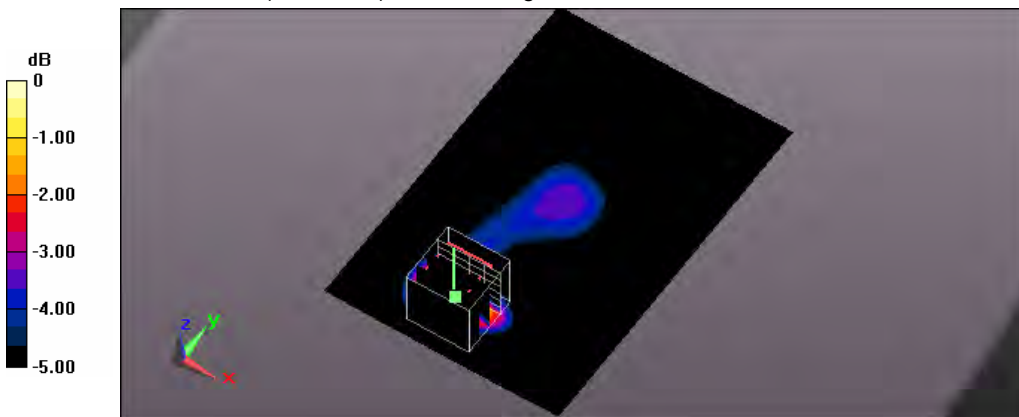

0 dB = 0.820 W/kg = -0.86 dBW/kg

Test Laboratory: A Test Lab Techno Corp.

Date: 2014/11/27 Time: PM 10:34:53

**43\_Flat\_LTE Band4 BW 20M CH20050\_QPSK with 1 RB Size 49 RB Offset side 3 surface to phantom 10mm**

**DUT: AC779S-200; Type: Mobile Hot Spot; Serial: 01426000002034**

Communication System: UID 0, Generic LTE (0); Frequency: 1720 MHz; Duty Cycle: 1:1

Medium parameters used:  $f = 1720 \text{ MHz}$ ;  $\sigma = 1.509 \text{ S/m}$ ;  $\epsilon_r = 54.329$ ;  $\rho = 1000 \text{ kg/m}^3$

Phantom section: Flat Section

Measurement Standard: DASYS (IEEE/IEC/ANSI C63.19-2011)

DASY Configuration:

- Area Scan setting - Find Secondary Maximum Within: 2.0dB and with a peak SAR value greater than 0.5 W/Kg
- Probe: EX3DV4 - SN3977; ConvF(7.69, 7.69, 7.69); Calibrated: 2014/2/17;
- Sensor-Surface: 2mm (Mechanical Surface Detection)
- Electronics: DAE4 Sn779; Calibrated: 2014/2/25
- Phantom: ELI v5.0; Type: QDOVA002AA; Serial: TP:1133
- Measurement SW: DASYS2, Version 52.8 (7); SEMCAD X Version 14.6.10 (7164)

**Flat/Area Scan (61x111x1):**

Interpolated grid:  $dx=1.500 \text{ mm}$ ,  $dy=1.500 \text{ mm}$

Maximum value of SAR (interpolated) = 0.0353 W/kg

**Flat/Zoom Scan (5x5x7)/Cube 0:**

Measurement grid:  $dx=8\text{mm}$ ,  $dy=8\text{mm}$ ,  $dz=5\text{mm}$

Reference Value = 3.710 V/m; Power Drift = -0.01 dB

Peak SAR (extrapolated) = 0.0390 W/kg

**SAR(1 g) = 0.024 W/kg; SAR(10 g) = 0.014 W/kg**

Maximum value of SAR (measured) = 0.0317 W/kg

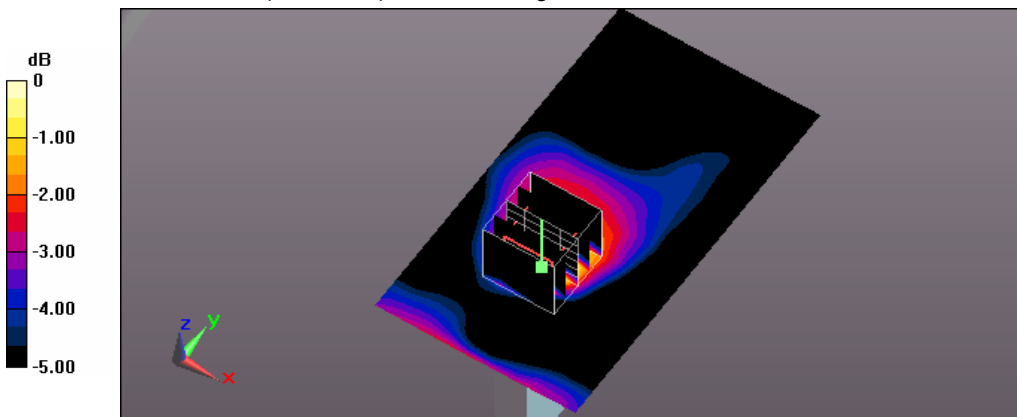

0 dB = 0.0317 W/kg = -14.99 dBW/kg

Test Laboratory: A Test Lab Techno Corp.

Date: 2014/11/28 Time: AM 12:20:59

**46\_Flat\_LTE Band4 BW 20M CH20050\_QPSK with 1 RB Size 49 RB Offset side 4 surface to phantom 10mm**

**DUT: AC779S-200; Type: Mobile Hot Spot; Serial: 01426000002034**

Communication System: UID 0, Generic LTE (0); Frequency: 1720 MHz; Duty Cycle: 1:1

Medium parameters used:  $f = 1720 \text{ MHz}$ ;  $\sigma = 1.509 \text{ S/m}$ ;  $\epsilon_r = 54.329$ ;  $\rho = 1000 \text{ kg/m}^3$

Phantom section: Flat Section

Measurement Standard: DASYS (IEEE/IEC/ANSI C63.19-2011)

DASY Configuration:

- Area Scan setting - Find Secondary Maximum Within: 2.0dB and with a peak SAR value greater than 0.5 W/Kg
- Probe: EX3DV4 - SN3977; ConvF(7.69, 7.69, 7.69); Calibrated: 2014/2/17;
- Sensor-Surface: 2mm (Mechanical Surface Detection)
- Electronics: DAE4 Sn779; Calibrated: 2014/2/25
- Phantom: ELI v5.0; Type: QDOVA002AA; Serial: TP:1133
- Measurement SW: DASYS2, Version 52.8 (7); SEMCAD X Version 14.6.10 (7164)

**Flat/Area Scan (61x111x1):**

Interpolated grid:  $dx=1.500 \text{ mm}$ ,  $dy=1.500 \text{ mm}$

Maximum value of SAR (interpolated) = 0.622 W/kg

**Flat/Zoom Scan (5x5x7)/Cube 0:**

Measurement grid:  $dx=8\text{mm}$ ,  $dy=8\text{mm}$ ,  $dz=5\text{mm}$

Reference Value = 16.175 V/m; Power Drift = 0.08 dB

Peak SAR (extrapolated) = 0.723 W/kg

**SAR(1 g) = 0.464 W/kg; SAR(10 g) = 0.282 W/kg**

Maximum value of SAR (measured) = 0.605 W/kg

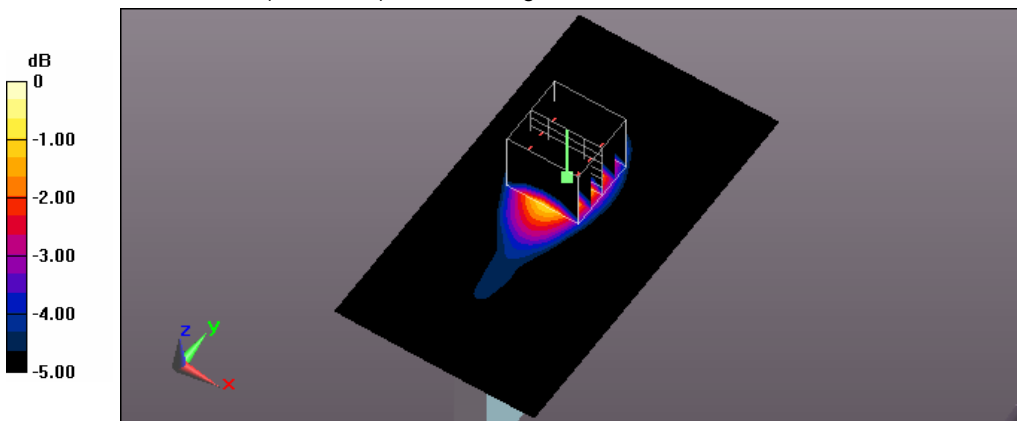

0 dB = 0.605 W/kg = -2.18 dBW/kg

Test Laboratory: A Test Lab Techno Corp.

Date: 2014/11/28 Time: AM 12:40:36

**47\_Flat\_LTE Band4 BW 20M CH20050\_QPSK with 1 RB Size 49 RB Offset side 5 surface to phantom 10mm**

**DUT: AC779S-200; Type: Mobile Hot Spot; Serial: 01426000002034**

Communication System: UID 0, Generic LTE (0); Frequency: 1720 MHz; Duty Cycle: 1:1

Medium parameters used:  $f = 1720 \text{ MHz}$ ;  $\sigma = 1.509 \text{ S/m}$ ;  $\epsilon_r = 54.329$ ;  $\rho = 1000 \text{ kg/m}^3$

Phantom section: Flat Section

Measurement Standard: DASYS (IEEE/IEC/ANSI C63.19-2011)

DASY Configuration:

- Area Scan setting - Find Secondary Maximum Within: 2.0dB and with a peak SAR value greater than 0.5 W/Kg
- Probe: EX3DV4 - SN3977; ConvF(7.69, 7.69, 7.69); Calibrated: 2014/2/17;
- Sensor-Surface: 2mm (Mechanical Surface Detection)
- Electronics: DAE4 Sn779; Calibrated: 2014/2/25
- Phantom: ELI v5.0; Type: QDOVA002AA; Serial: TP:1133
- Measurement SW: DASYS2, Version 52.8 (7); SEMCAD X Version 14.6.10 (7164)

**Flat/Area Scan (61x101x1):**

Interpolated grid:  $dx=1.500 \text{ mm}$ ,  $dy=1.500 \text{ mm}$

Maximum value of SAR (interpolated) = 1.39 W/kg

**Flat/Zoom Scan (5x5x7)/Cube 0:**

Measurement grid:  $dx=8\text{mm}$ ,  $dy=8\text{mm}$ ,  $dz=5\text{mm}$

Reference Value = 24.998 V/m; Power Drift = 0.07 dB

Peak SAR (extrapolated) = 1.67 W/kg

**SAR(1 g) = 1.01 W/kg; SAR(10 g) = 0.561 W/kg**

Maximum value of SAR (measured) = 1.33 W/kg

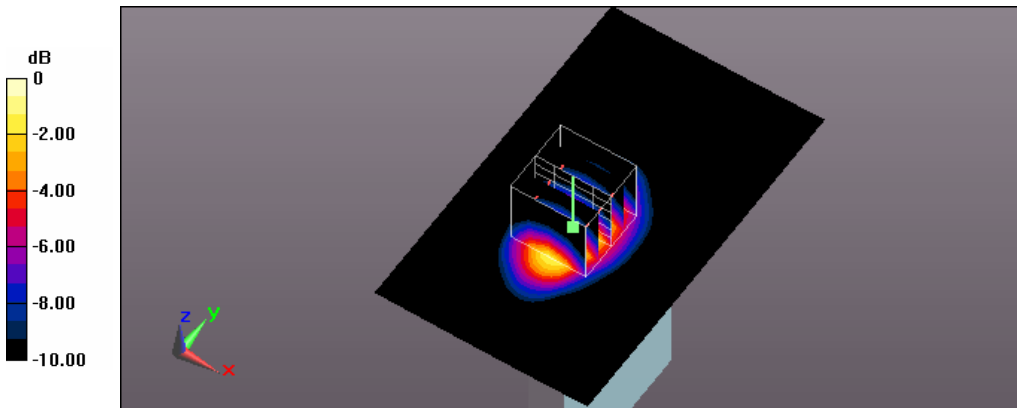

0 dB = 1.33 W/kg = 1.24 dBW/kg



Test Laboratory: A Test Lab Techno Corp.

Date: 2014/11/27 Time: PM 06:40:48

**35\_Flat\_LTE Band4 BW 20M CH20175\_QPSK with 1 RB Size 0 RB Offset side 1 surface to phantom 10mm**

**DUT: AC779S-200; Type: Mobile Hot Spot; Serial: 01426000002034**

Communication System: UID 0, Generic LTE (0); Frequency: 1732.5 MHz; Duty Cycle: 1:1

Medium parameters used (interpolated):  $f = 1732.5$  MHz;  $\sigma = 1.517$  S/m;  $\epsilon_r = 54.32$ ;  $\rho = 1000$  kg/m<sup>3</sup>

Phantom section: Flat Section

Measurement Standard: DASY5 (IEEE/IEC/ANSI C63.19-2011)

DASY Configuration:

- Area Scan setting - Find Secondary Maximum Within: 2.0dB and with a peak SAR value greater than 0.5 W/Kg
- Probe: EX3DV4 - SN3977; ConvF(7.69, 7.69, 7.69); Calibrated: 2014/2/17;
- Sensor-Surface: 2mm (Mechanical Surface Detection)
- Electronics: DAE4 Sn779; Calibrated: 2014/2/25
- Phantom: ELI v5.0; Type: QDOVA002AA; Serial: TP:1133
- Measurement SW: DASY52, Version 52.8 (7); SEMCAD X Version 14.6.10 (7164)

**Flat/Area Scan (81x121x1):**

Interpolated grid: dx=1.500 mm, dy=1.500 mm

Maximum value of SAR (interpolated) = 1.70 W/kg

**Flat/Zoom Scan (5x5x7)/Cube 0:**

Measurement grid: dx=8mm, dy=8mm, dz=5mm

Reference Value = 13.350 V/m; Power Drift = -0.02 dB

Peak SAR (extrapolated) = 2.12 W/kg

**SAR(1 g) = 1.24 W/kg; SAR(10 g) = 0.656 W/kg**

Maximum value of SAR (measured) = 1.73 W/kg

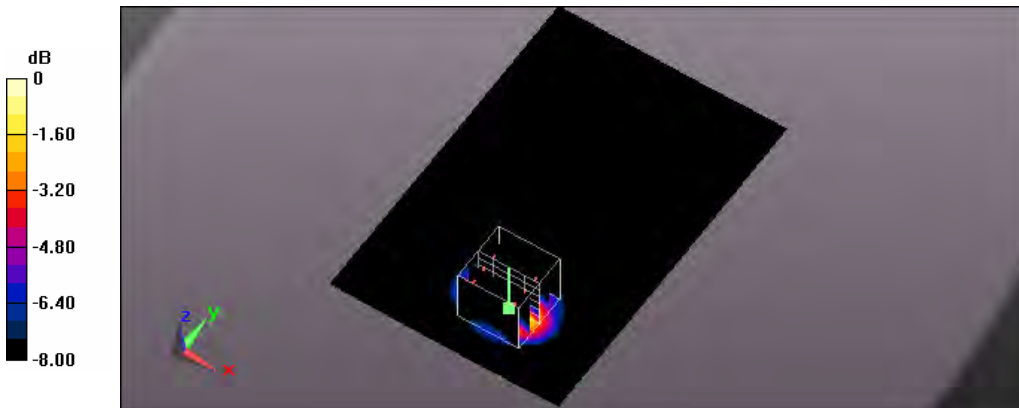

0 dB = 1.73 W/kg = 2.38 dBW/kg

Test Laboratory: A Test Lab Techno Corp.

Date: 2014/11/28 Time: AM 01:00:01

**48\_Flat\_LTE Band4 BW 20M CH20175\_QPSK with 1 RB Size 0 RB Offset side 5 surface to phantom 10mm**

**DUT: AC779S-200; Type: Mobile Hot Spot; Serial: 01426000002034**

Communication System: UID 0, Generic LTE (0); Frequency: 1732.5 MHz; Duty Cycle: 1:1

Medium parameters used (interpolated):  $f = 1732.5$  MHz;  $\sigma = 1.517$  S/m;  $\epsilon_r = 54.32$ ;  $\rho = 1000$  kg/m<sup>3</sup>

Phantom section: Flat Section

Measurement Standard: DASY5 (IEEE/IEC/ANSI C63.19-2011)

DASY Configuration:

- Area Scan setting - Find Secondary Maximum Within: 2.0dB and with a peak SAR value greater than 0.5 W/Kg
- Probe: EX3DV4 - SN3977; ConvF(7.69, 7.69, 7.69); Calibrated: 2014/2/17;
- Sensor-Surface: 2mm (Mechanical Surface Detection)
- Electronics: DAE4 Sn779; Calibrated: 2014/2/25
- Phantom: ELI v5.0; Type: QDOVA002AA; Serial: TP:1133
- Measurement SW: DASY52, Version 52.8 (7); SEMCAD X Version 14.6.10 (7164)

**Flat/Area Scan (61x101x1):**

Interpolated grid: dx=1.500 mm, dy=1.500 mm

Maximum value of SAR (interpolated) = 1.41 W/kg

**Flat/Zoom Scan (5x5x7)/Cube 0:**

Measurement grid: dx=8mm, dy=8mm, dz=5mm

Reference Value = 25.252 V/m; Power Drift = 0.05 dB

Peak SAR (extrapolated) = 1.69 W/kg

**SAR(1 g) = 1.03 W/kg; SAR(10 g) = 0.568 W/kg**

Maximum value of SAR (measured) = 1.35 W/kg

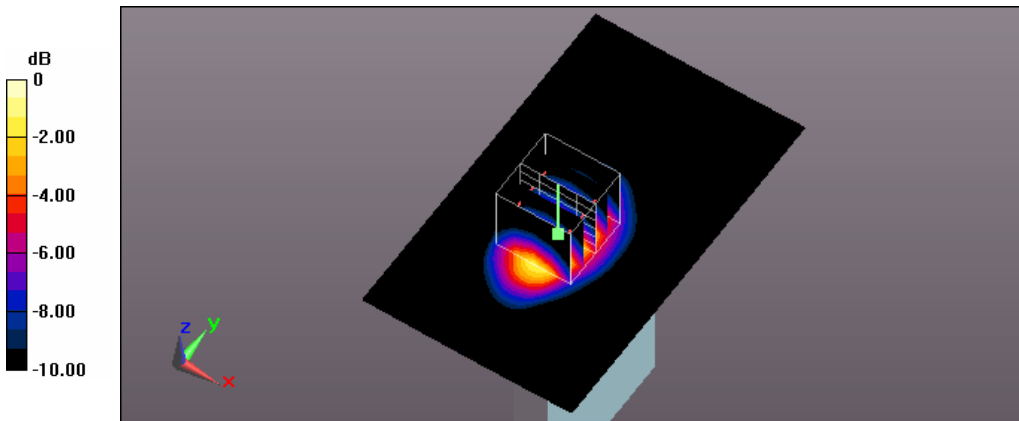

0 dB = 1.35 W/kg = 1.30 dBW/kg

Test Laboratory: A Test Lab Techno Corp.

Date: 2014/11/27 Time: PM 07:03:55

**36\_Flat\_LTE Band4 BW 20M CH20300\_QPSK with 1 RB Size 0 RB Offset side 1 surface to phantom 10mm**

**DUT: AC779S-200; Type: Mobile Hot Spot; Serial: 01426000002034**

Communication System: UID 0, Generic LTE (0); Frequency: 1745 MHz; Duty Cycle: 1:1

Medium parameters used:  $f = 1745 \text{ MHz}$ ;  $\sigma = 1.527 \text{ S/m}$ ;  $\epsilon_r = 54.307$ ;  $\rho = 1000 \text{ kg/m}^3$

Phantom section: Flat Section

Measurement Standard: DASYS (IEEE/IEC/ANSI C63.19-2011)

DASY Configuration:

- Area Scan setting - Find Secondary Maximum Within: 2.0dB and with a peak SAR value greater than 0.5 W/Kg
- Probe: EX3DV4 - SN3977; ConvF(7.69, 7.69, 7.69); Calibrated: 2014/2/17;
- Sensor-Surface: 2mm (Mechanical Surface Detection)
- Electronics: DAE4 Sn779; Calibrated: 2014/2/25
- Phantom: ELI v5.0; Type: QDOVA002AA; Serial: TP:1133
- Measurement SW: DASYS2, Version 52.8 (7); SEMCAD X Version 14.6.10 (7164)

**Flat/Area Scan (81x121x1):**

Interpolated grid:  $dx=1.500 \text{ mm}$ ,  $dy=1.500 \text{ mm}$

Maximum value of SAR (interpolated) = 1.68 W/kg

**Flat/Zoom Scan (5x5x7)/Cube 0:**

Measurement grid:  $dx=8\text{mm}$ ,  $dy=8\text{mm}$ ,  $dz=5\text{mm}$

Reference Value = 13.677 V/m; Power Drift = -0.03 dB

Peak SAR (extrapolated) = 2.12 W/kg

**SAR(1 g) = 1.23 W/kg; SAR(10 g) = 0.650 W/kg**

Maximum value of SAR (measured) = 1.72 W/kg

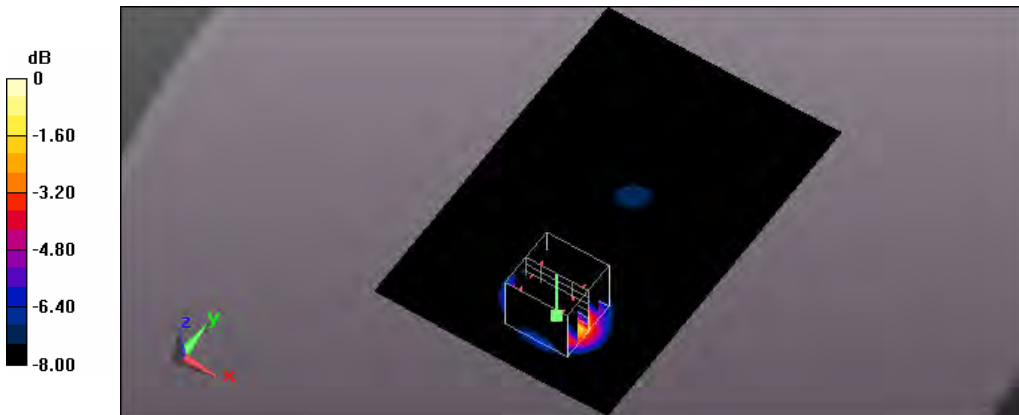

0 dB = 1.72 W/kg = 2.36 dBW/kg

Test Laboratory: A Test Lab Techno Corp.

Date: 2014/11/28 Time: AM 01:17:10

**49\_Flat\_LTE Band4 BW 20M CH20300\_QPSK with 1 RB Size 0 RB Offset side 5 surface to phantom 10mm**

**DUT: AC779S-200; Type: Mobile Hot Spot; Serial: 01426000002034**

Communication System: UID 0, Generic LTE (0); Frequency: 1745 MHz; Duty Cycle: 1:1

Medium parameters used:  $f = 1745 \text{ MHz}$ ;  $\sigma = 1.527 \text{ S/m}$ ;  $\epsilon_r = 54.307$ ;  $\rho = 1000 \text{ kg/m}^3$

Phantom section: Flat Section

Measurement Standard: DASYS (IEEE/IEC/ANSI C63.19-2011)

DASY Configuration:

- Area Scan setting - Find Secondary Maximum Within: 2.0dB and with a peak SAR value greater than 0.5 W/Kg
- Probe: EX3DV4 - SN3977; ConvF(7.69, 7.69, 7.69); Calibrated: 2014/2/17;
- Sensor-Surface: 2mm (Mechanical Surface Detection)
- Electronics: DAE4 Sn779; Calibrated: 2014/2/25
- Phantom: ELI v5.0; Type: QDOVA002AA; Serial: TP:1133
- Measurement SW: DASYS2, Version 52.8 (7); SEMCAD X Version 14.6.10 (7164)

**Flat/Area Scan (61x101x1):**

Interpolated grid:  $dx=1.500 \text{ mm}$ ,  $dy=1.500 \text{ mm}$

Maximum value of SAR (interpolated) = 1.38 W/kg

**Flat/Zoom Scan (5x5x7)/Cube 0:**

Measurement grid:  $dx=8\text{mm}$ ,  $dy=8\text{mm}$ ,  $dz=5\text{mm}$

Reference Value = 24.786 V/m; Power Drift = 0.05 dB

Peak SAR (extrapolated) = 1.65 W/kg

**SAR(1 g) = 1 W/kg; SAR(10 g) = 0.555 W/kg**

Maximum value of SAR (measured) = 1.33 W/kg

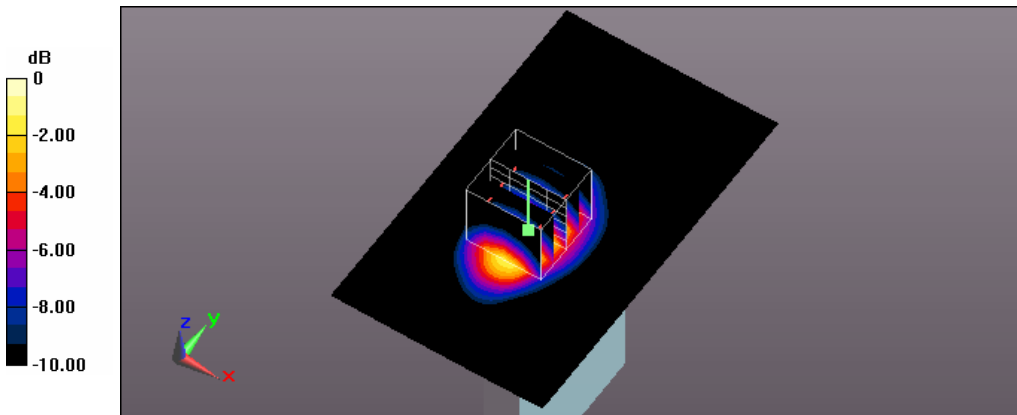

0 dB = 1.33 W/kg = 1.24 dBW/kg

Test Laboratory: A Test Lab Techno Corp.

Date: 2014/11/27 Time: PM 08:26:48

**38\_Flat\_LTE Band4 BW 20M CH20050\_QPSK with 50 RB Size 50 RB Offset side 1 surface to phantom 10mm**

**DUT: AC779S-200; Type: Mobile Hot Spot; Serial: 01426000002034**

Communication System: UID 0, Generic LTE (0); Frequency: 1720 MHz; Duty Cycle: 1:1

Medium parameters used:  $f = 1720 \text{ MHz}$ ;  $\sigma = 1.509 \text{ S/m}$ ;  $\epsilon_r = 54.329$ ;  $\rho = 1000 \text{ kg/m}^3$

Phantom section: Flat Section

Measurement Standard: DASY5 (IEEE/IEC/ANSI C63.19-2011)

DASY Configuration:

- Area Scan setting - Find Secondary Maximum Within: 2.0dB and with a peak SAR value greater than 0.5 W/Kg
- Probe: EX3DV4 - SN3977; ConvF(7.69, 7.69, 7.69); Calibrated: 2014/2/17;
- Sensor-Surface: 2mm (Mechanical Surface Detection)
- Electronics: DAE4 Sn779; Calibrated: 2014/2/25
- Phantom: ELI v5.0; Type: QDOVA002AA; Serial: TP:1133
- Measurement SW: DASY52, Version 52.8 (7); SEMCAD X Version 14.6.10 (7164)

**Flat/Area Scan (81x121x1):**

Interpolated grid:  $dx=1.500 \text{ mm}$ ,  $dy=1.500 \text{ mm}$

Maximum value of SAR (interpolated) = 1.28 W/kg

**Flat/Zoom Scan (5x5x7)/Cube 0:**

Measurement grid:  $dx=8\text{mm}$ ,  $dy=8\text{mm}$ ,  $dz=5\text{mm}$

Reference Value = 11.615 V/m; Power Drift = 0.05 dB

Peak SAR (extrapolated) = 1.65 W/kg

**SAR(1 g) = 0.949 W/kg; SAR(10 g) = 0.502 W/kg**

Maximum value of SAR (measured) = 1.33 W/kg

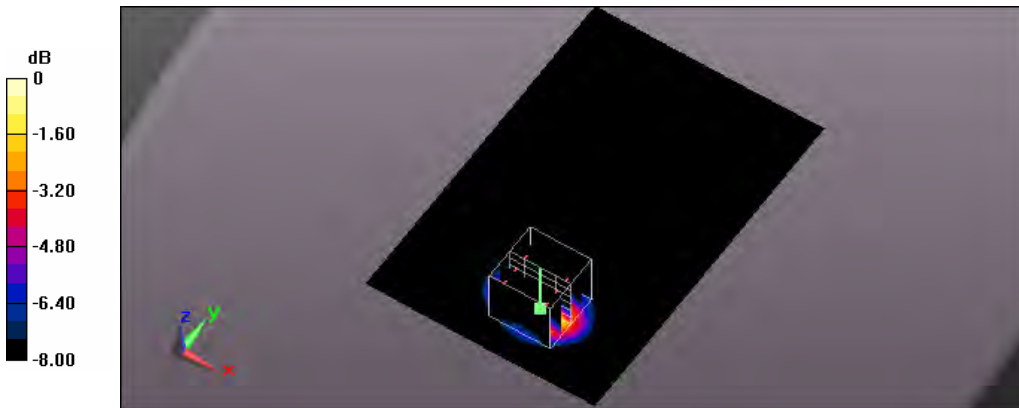

0 dB = 1.33 W/kg = 1.24 dBW/kg

Test Laboratory: A Test Lab Techno Corp.

Date: 2014/11/28 Time: AM 02:11:46

**51\_Flat\_LTE Band4 BW 20M CH20050\_QPSK with 50 RB Size 50 RB Offset side 5 surface to phantom 10mm**

**DUT: AC779S-200; Type: Mobile Hot Spot; Serial: 01426000002034**

Communication System: UID 0, Generic LTE (0); Frequency: 1720 MHz; Duty Cycle: 1:1

Medium parameters used:  $f = 1720$  MHz;  $\sigma = 1.509$  S/m;  $\epsilon_r = 54.329$ ;  $\rho = 1000$  kg/m<sup>3</sup>

Phantom section: Flat Section

Measurement Standard: DASY5 (IEEE/IEC/ANSI C63.19-2011)

DASY Configuration:

- Area Scan setting - Find Secondary Maximum Within: 2.0dB and with a peak SAR value greater than 0.5 W/Kg
- Probe: EX3DV4 - SN3977; ConvF(7.69, 7.69, 7.69); Calibrated: 2014/2/17;
- Sensor-Surface: 2mm (Mechanical Surface Detection)
- Electronics: DAE4 Sn779; Calibrated: 2014/2/25
- Phantom: ELI v5.0; Type: QDOVA002AA; Serial: TP:1133
- Measurement SW: DASY52, Version 52.8 (7); SEMCAD X Version 14.6.10 (7164)

**Flat/Area Scan (61x101x1):**

Interpolated grid: dx=1.500 mm, dy=1.500 mm

Maximum value of SAR (interpolated) = 1.07 W/kg

**Flat/Zoom Scan (5x5x7)/Cube 0:**

Measurement grid: dx=8mm, dy=8mm, dz=5mm

Reference Value = 22.152 V/m; Power Drift = 0.05 dB

Peak SAR (extrapolated) = 1.26 W/kg

**SAR(1 g) = 0.766 W/kg; SAR(10 g) = 0.425 W/kg**

Maximum value of SAR (measured) = 1.01 W/kg

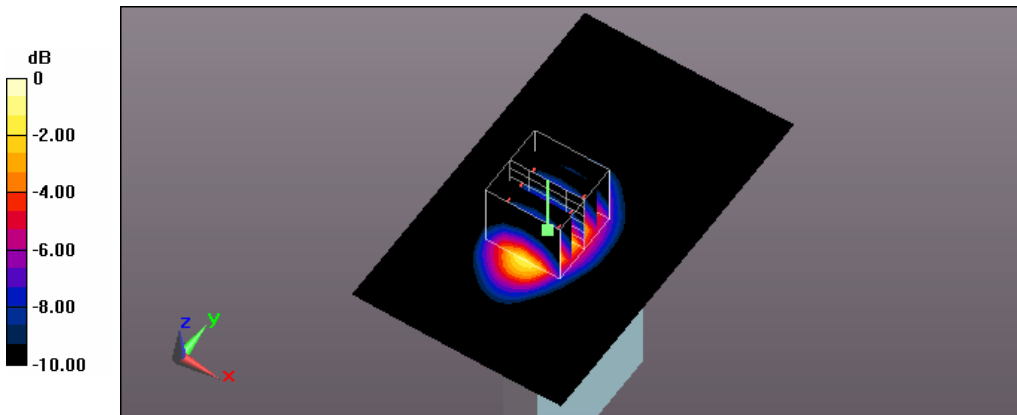

0 dB = 1.01 W/kg = 0.04 dBW/kg

Test Laboratory: A Test Lab Techno Corp.

Date: 2014/11/27 Time: PM 07:27:13

**37\_Flat\_LTE Band4 BW 20M CH20175\_QPSK with 50 RB Size 0 RB Offset side 1 surface to phantom 10mm**

**DUT: AC779S-200; Type: Mobile Hot Spot; Serial: 01426000002034**

Communication System: UID 0, Generic LTE (0); Frequency: 1732.5 MHz; Duty Cycle: 1:1

Medium parameters used (interpolated):  $f = 1732.5$  MHz;  $\sigma = 1.517$  S/m;  $\epsilon_r = 54.32$ ;  $\rho = 1000$  kg/m<sup>3</sup>

Phantom section: Flat Section

Measurement Standard: DASY5 (IEEE/IEC/ANSI C63.19-2011)

DASY Configuration:

- Area Scan setting - Find Secondary Maximum Within: 2.0dB and with a peak SAR value greater than 0.5 W/Kg
- Probe: EX3DV4 - SN3977; ConvF(7.69, 7.69, 7.69); Calibrated: 2014/2/17;
- Sensor-Surface: 2mm (Mechanical Surface Detection)
- Electronics: DAE4 Sn779; Calibrated: 2014/2/25
- Phantom: ELI v5.0; Type: QDOVA002AA; Serial: TP:1133
- Measurement SW: DASY52, Version 52.8 (7); SEMCAD X Version 14.6.10 (7164)

**Flat/Area Scan (81x121x1):**

Interpolated grid: dx=1.500 mm, dy=1.500 mm

Maximum value of SAR (interpolated) = 1.31 W/kg

**Flat/Zoom Scan (5x5x7)/Cube 0:**

Measurement grid: dx=8mm, dy=8mm, dz=5mm

Reference Value = 11.823 V/m; Power Drift = -0.10 dB

Peak SAR (extrapolated) = 1.61 W/kg

**SAR(1 g) = 0.941 W/kg; SAR(10 g) = 0.499 W/kg**

Maximum value of SAR (measured) = 1.31 W/kg

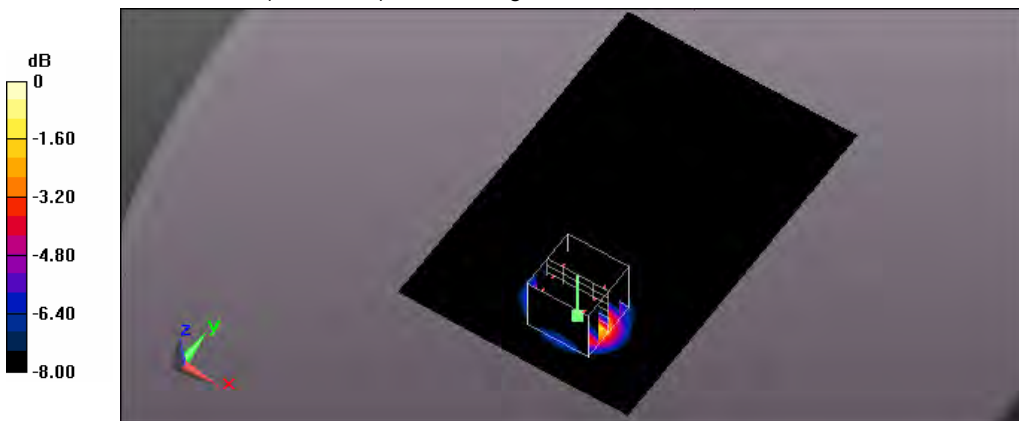

0 dB = 1.31 W/kg = 1.17 dBW/kg

Test Laboratory: A Test Lab Techno Corp.

Date: 2014/11/27 Time: PM 09:45:12

**41\_Flat\_LTE Band4 BW 20M CH20175\_QPSK with 50 RB Size 0 RB Offset side 2 surface to phantom 10mm**

**DUT: AC779S-200; Type: Mobile Hot Spot; Serial: 01426000002034**

Communication System: UID 0, Generic LTE (0); Frequency: 1732.5 MHz; Duty Cycle: 1:1

Medium parameters used (interpolated):  $f = 1732.5$  MHz;  $\sigma = 1.517$  S/m;  $\epsilon_r = 54.32$ ;  $\rho = 1000$  kg/m<sup>3</sup>

Phantom section: Flat Section

Measurement Standard: DASY5 (IEEE/IEC/ANSI C63.19-2011)

DASY Configuration:

- Area Scan setting - Find Secondary Maximum Within: 2.0dB and with a peak SAR value greater than 0.5 W/Kg
- Probe: EX3DV4 - SN3977; ConvF(7.69, 7.69, 7.69); Calibrated: 2014/2/17;
- Sensor-Surface: 2mm (Mechanical Surface Detection)
- Electronics: DAE4 Sn779; Calibrated: 2014/2/25
- Phantom: ELI v5.0; Type: QDOVA002AA; Serial: TP:1133
- Measurement SW: DASY52, Version 52.8 (7); SEMCAD X Version 14.6.10 (7164)

**Flat/Area Scan (81x121x1):**

Interpolated grid: dx=1.500 mm, dy=1.500 mm

Maximum value of SAR (interpolated) = 0.660 W/kg

**Flat/Zoom Scan (5x5x7)/Cube 0:**

Measurement grid: dx=8mm, dy=8mm, dz=5mm

Reference Value = 13.990 V/m; Power Drift = -0.04 dB

Peak SAR (extrapolated) = 0.808 W/kg

**SAR(1 g) = 0.491 W/kg; SAR(10 g) = 0.277 W/kg**

Maximum value of SAR (measured) = 0.628 W/kg

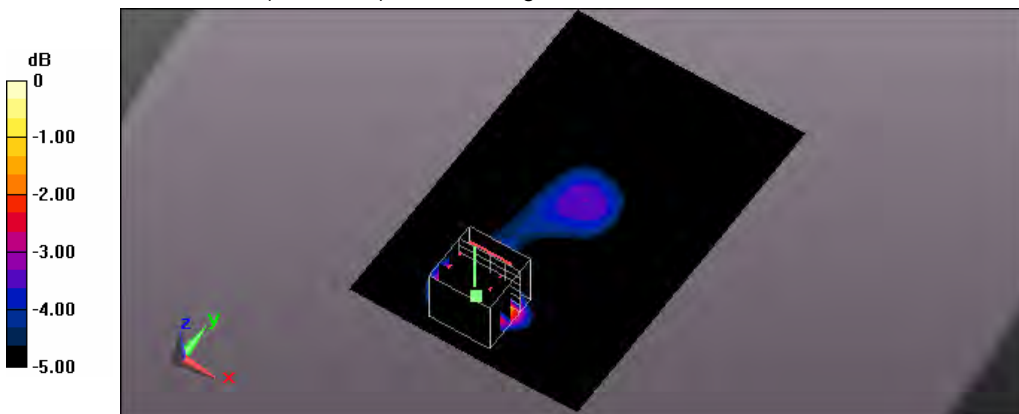

0 dB = 0.628 W/kg = -2.02 dBW/kg



Test Laboratory: A Test Lab Techno Corp.

Date: 2014/11/27 Time: PM 10:53:09

**44\_Flat\_LTE Band4 BW 20M CH20175\_QPSK with 50 RB Size 0 RB Offset side 3 surface to phantom 10mm**

**DUT: AC779S-200; Type: Mobile Hot Spot; Serial: 01426000002034**

Communication System: UID 0, Generic LTE (0); Frequency: 1732.5 MHz; Duty Cycle: 1:1

Medium parameters used (interpolated):  $f = 1732.5$  MHz;  $\sigma = 1.517$  S/m;  $\epsilon_r = 54.32$ ;  $\rho = 1000$  kg/m<sup>3</sup>

Phantom section: Flat Section

Measurement Standard: DASY5 (IEEE/IEC/ANSI C63.19-2011)

DASY Configuration:

- Area Scan setting - Find Secondary Maximum Within: 2.0dB and with a peak SAR value greater than 0.5 W/Kg
- Probe: EX3DV4 - SN3977; ConvF(7.69, 7.69, 7.69); Calibrated: 2014/2/17;
- Sensor-Surface: 2mm (Mechanical Surface Detection)
- Electronics: DAE4 Sn779; Calibrated: 2014/2/25
- Phantom: ELI v5.0; Type: QDOVA002AA; Serial: TP:1133
- Measurement SW: DASY52, Version 52.8 (7); SEMCAD X Version 14.6.10 (7164)

**Flat/Area Scan (61x111x1):**

Interpolated grid: dx=1.500 mm, dy=1.500 mm

Maximum value of SAR (interpolated) = 0.0334 W/kg

**Flat/Zoom Scan (5x5x7)/Cube 0:**

Measurement grid: dx=8mm, dy=8mm, dz=5mm

Reference Value = 3.613 V/m; Power Drift = -0.06 dB

Peak SAR (extrapolated) = 0.0370 W/kg

**SAR(1 g) = 0.023 W/kg; SAR(10 g) = 0.014 W/kg**

Maximum value of SAR (measured) = 0.0302 W/kg

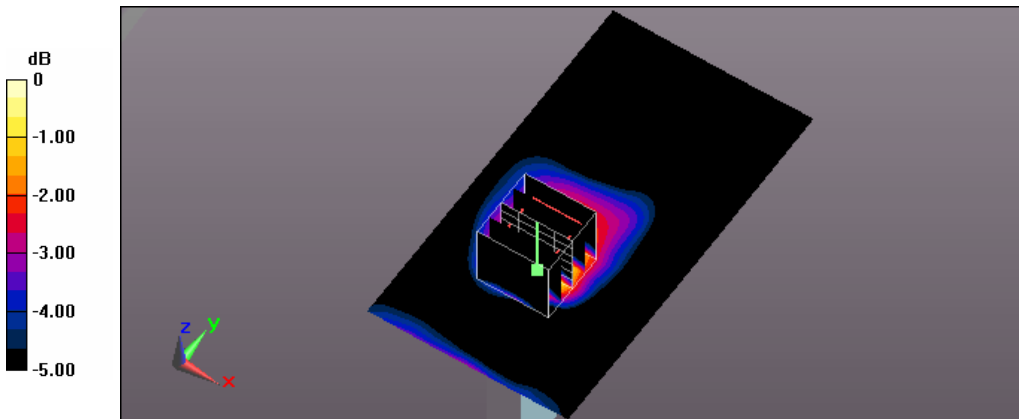

0 dB = 0.0302 W/kg = -15.20 dBW/kg

Test Laboratory: A Test Lab Techno Corp.

Date: 2014/11/28 Time: AM 12:03:07

**45\_Flat\_LTE Band4 BW 20M CH20175\_QPSK with 50 RB Size 0 RB Offset side 4 surface to phantom 10mm**

**DUT: AC779S-200; Type: Mobile Hot Spot; Serial: 01426000002034**

Communication System: UID 0, Generic LTE (0); Frequency: 1732.5 MHz; Duty Cycle: 1:1

Medium parameters used (interpolated):  $f = 1732.5$  MHz;  $\sigma = 1.517$  S/m;  $\epsilon_r = 54.32$ ;  $\rho = 1000$  kg/m<sup>3</sup>

Phantom section: Flat Section

Measurement Standard: DASYS (IEEE/IEC/ANSI C63.19-2011)

DASY Configuration:

- Area Scan setting - Find Secondary Maximum Within: 2.0dB and with a peak SAR value greater than 0.5 W/Kg
- Probe: EX3DV4 - SN3977; ConvF(7.69, 7.69, 7.69); Calibrated: 2014/2/17;
- Sensor-Surface: 2mm (Mechanical Surface Detection)
- Electronics: DAE4 Sn779; Calibrated: 2014/2/25
- Phantom: ELI v5.0; Type: QDOVA002AA; Serial: TP:1133
- Measurement SW: DASYS2, Version 52.8 (7); SEMCAD X Version 14.6.10 (7164)

**Flat/Area Scan (61x111x1):**

Interpolated grid: dx=1.500 mm, dy=1.500 mm

Maximum value of SAR (interpolated) = 0.458 W/kg

**Flat/Zoom Scan (5x5x7)/Cube 0:**

Measurement grid: dx=8mm, dy=8mm, dz=5mm

Reference Value = 14.076 V/m; Power Drift = 0.07 dB

Peak SAR (extrapolated) = 0.534 W/kg

**SAR(1 g) = 0.341 W/kg; SAR(10 g) = 0.206 W/kg**

Maximum value of SAR (measured) = 0.447 W/kg

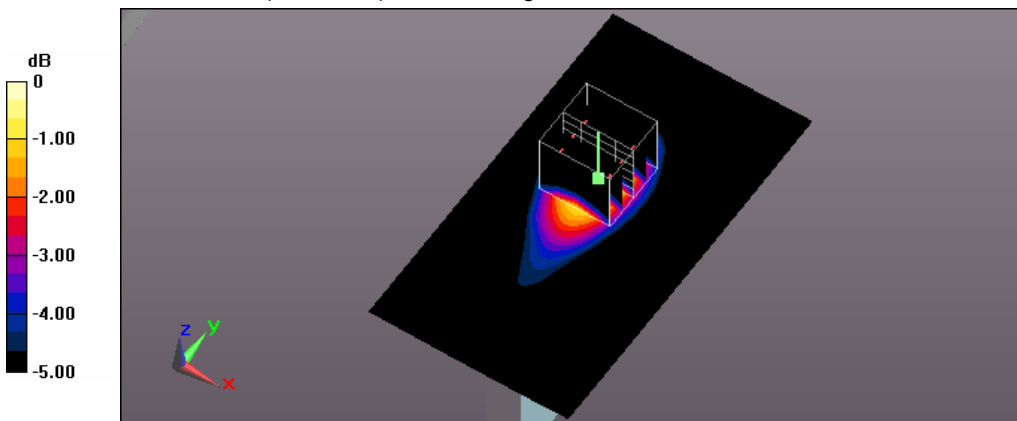

0 dB = 0.447 W/kg = -3.50 dBW/kg

Test Laboratory: A Test Lab Techno Corp.

Date: 2014/11/28 Time: AM 01:34:15

**50\_Flat\_LTE Band4 BW 20M CH20175\_QPSK with 50 RB Size 0 RB Offset side 5 surface to phantom 10mm**

**DUT: AC779S-200; Type: Mobile Hot Spot; Serial: 01426000002034**

Communication System: UID 0, Generic LTE (0); Frequency: 1732.5 MHz; Duty Cycle: 1:1

Medium parameters used (interpolated):  $f = 1732.5$  MHz;  $\sigma = 1.517$  S/m;  $\epsilon_r = 54.32$ ;  $\rho = 1000$  kg/m<sup>3</sup>

Phantom section: Flat Section

Measurement Standard: DASYS (IEEE/IEC/ANSI C63.19-2011)

DASY Configuration:

- Area Scan setting - Find Secondary Maximum Within: 2.0dB and with a peak SAR value greater than 0.5 W/Kg
- Probe: EX3DV4 - SN3977; ConvF(7.69, 7.69, 7.69); Calibrated: 2014/2/17;
- Sensor-Surface: 2mm (Mechanical Surface Detection)
- Electronics: DAE4 Sn779; Calibrated: 2014/2/25
- Phantom: ELI v5.0; Type: QDOVA002AA; Serial: TP:1133
- Measurement SW: DASYS2, Version 52.8 (7); SEMCAD X Version 14.6.10 (7164)

**Flat/Area Scan (61x101x1):**

Interpolated grid: dx=1.500 mm, dy=1.500 mm

Maximum value of SAR (interpolated) = 1.07 W/kg

**Flat/Zoom Scan (5x5x7)/Cube 0:**

Measurement grid: dx=8mm, dy=8mm, dz=5mm

Reference Value = 21.912 V/m; Power Drift = 0.07 dB

Peak SAR (extrapolated) = 1.27 W/kg

**SAR(1 g) = 0.771 W/kg; SAR(10 g) = 0.426 W/kg**

Maximum value of SAR (measured) = 1.02 W/kg

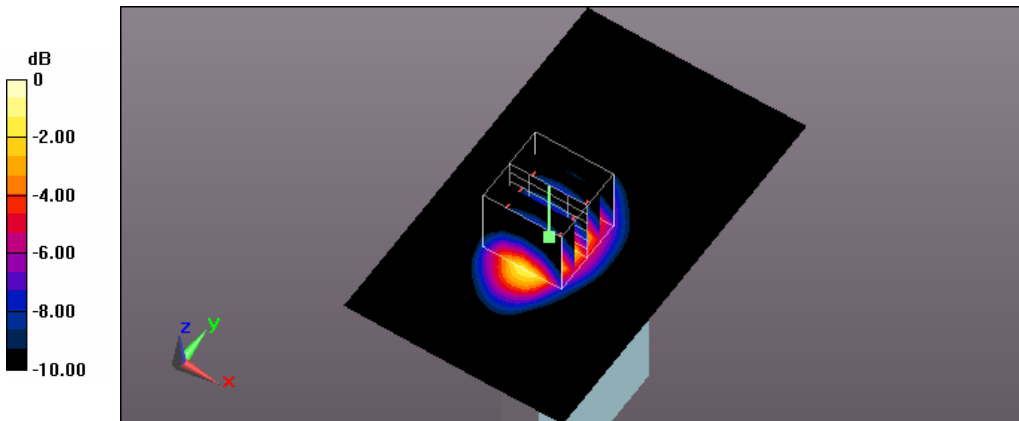

0 dB = 1.02 W/kg = 0.09 dBW/kg

Test Laboratory: A Test Lab Techno Corp.

Date: 2014/11/27 Time: PM 08:50:26

**39\_Flat\_LTE Band4 BW 20M CH20300\_QPSK with 50 RB Size 0 RB Offset side 1 surface to phantom 10mm**

**DUT: AC779S-200; Type: Mobile Hot Spot; Serial: 01426000002034**

Communication System: UID 0, Generic LTE (0); Frequency: 1745 MHz; Duty Cycle: 1:1

Medium parameters used:  $f = 1745 \text{ MHz}$ ;  $\sigma = 1.527 \text{ S/m}$ ;  $\epsilon_r = 54.307$ ;  $\rho = 1000 \text{ kg/m}^3$

Phantom section: Flat Section

Measurement Standard: DASYS (IEEE/IEC/ANSI C63.19-2011)

DASY Configuration:

- Area Scan setting - Find Secondary Maximum Within: 2.0dB and with a peak SAR value greater than 0.5 W/Kg
- Probe: EX3DV4 - SN3977; ConvF(7.69, 7.69, 7.69); Calibrated: 2014/2/17;
- Sensor-Surface: 2mm (Mechanical Surface Detection)
- Electronics: DAE4 Sn779; Calibrated: 2014/2/25
- Phantom: ELI v5.0; Type: QDOVA002AA; Serial: TP:1133
- Measurement SW: DASYS2, Version 52.8 (7); SEMCAD X Version 14.6.10 (7164)

**Flat/Area Scan (81x121x1):**

Interpolated grid:  $dx=1.500 \text{ mm}$ ,  $dy=1.500 \text{ mm}$

Maximum value of SAR (interpolated) = 1.32 W/kg

**Flat/Zoom Scan (5x5x7)/Cube 0:**

Measurement grid:  $dx=8\text{mm}$ ,  $dy=8\text{mm}$ ,  $dz=5\text{mm}$

Reference Value = 12.028 V/m; Power Drift = 0.08 dB

Peak SAR (extrapolated) = 1.64 W/kg

**SAR(1 g) = 0.945 W/kg; SAR(10 g) = 0.500 W/kg**

Maximum value of SAR (measured) = 1.32 W/kg

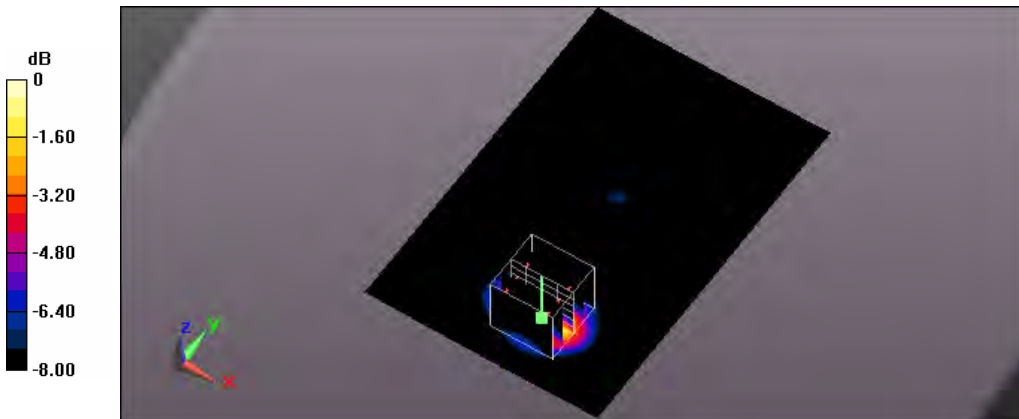

0 dB = 1.32 W/kg = 1.21 dBW/kg

Test Laboratory: A Test Lab Techno Corp.

Date: 2014/11/28 Time: AM 02:29:15

**52\_Flat\_LTE Band4 BW 20M CH20300\_QPSK with 50 RB Size 0 RB Offset side 5 surface to phantom 10mm**

**DUT: AC779S-200; Type: Mobile Hot Spot; Serial: 01426000002034**

Communication System: UID 0, Generic LTE (0); Frequency: 1745 MHz; Duty Cycle: 1:1

Medium parameters used:  $f = 1745 \text{ MHz}$ ;  $\sigma = 1.527 \text{ S/m}$ ;  $\epsilon_r = 54.307$ ;  $\rho = 1000 \text{ kg/m}^3$

Phantom section: Flat Section

Measurement Standard: DASYS (IEEE/IEC/ANSI C63.19-2011)

DASY Configuration:

- Area Scan setting - Find Secondary Maximum Within: 2.0dB and with a peak SAR value greater than 0.5 W/Kg
- Probe: EX3DV4 - SN3977; ConvF(7.69, 7.69, 7.69); Calibrated: 2014/2/17;
- Sensor-Surface: 2mm (Mechanical Surface Detection)
- Electronics: DAE4 Sn779; Calibrated: 2014/2/25
- Phantom: ELI v5.0; Type: QDOVA002AA; Serial: TP:1133
- Measurement SW: DASYS2, Version 52.8 (7); SEMCAD X Version 14.6.10 (7164)

**Flat/Area Scan (61x101x1):**

Interpolated grid:  $dx=1.500 \text{ mm}$ ,  $dy=1.500 \text{ mm}$

Maximum value of SAR (interpolated) = 1.04 W/kg

**Flat/Zoom Scan (5x5x7)/Cube 0:**

Measurement grid:  $dx=8\text{mm}$ ,  $dy=8\text{mm}$ ,  $dz=5\text{mm}$

Reference Value = 21.599 V/m; Power Drift = 0.15 dB

Peak SAR (extrapolated) = 1.27 W/kg

**SAR(1 g) = 0.764 W/kg; SAR(10 g) = 0.422 W/kg**

Maximum value of SAR (measured) = 1.02 W/kg

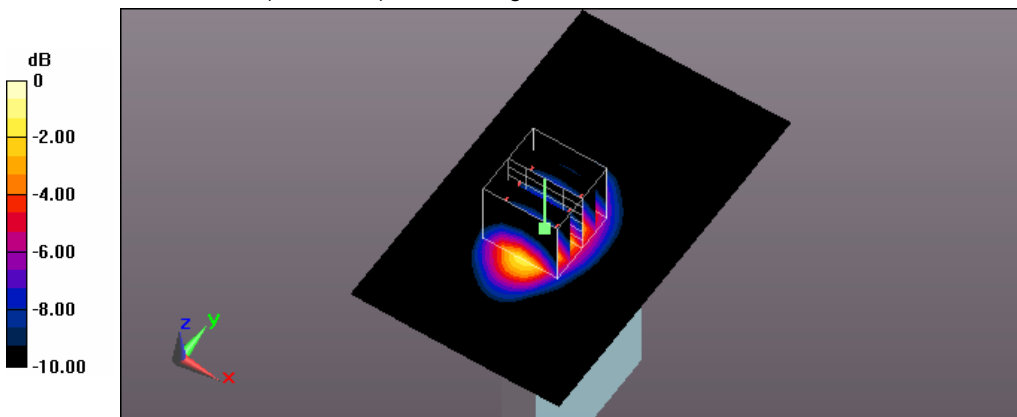

0 dB = 1.02 W/kg = 0.09 dBW/kg

Test Laboratory: A Test Lab Techno Corp.

Date: 2014/11/27 Time: PM 09:12:34

**40\_Flat\_LTE Band4 BW 20M CH20175\_QPSK with 100 RB Size 0 RB Offset side 1 surface to phantom 10mm**

**DUT: AC779S-200; Type: Mobile Hot Spot; Serial: 014260000002034**

Communication System: UID 0, Generic LTE (0); Frequency: 1732.5 MHz; Duty Cycle: 1:1

Medium parameters used (interpolated):  $f = 1732.5$  MHz;  $\sigma = 1.517$  S/m;  $\epsilon_r = 54.32$ ;  $\rho = 1000$  kg/m<sup>3</sup>

Phantom section: Flat Section

Measurement Standard: DASYS (IEEE/IEC/ANSI C63.19-2011)

DASY Configuration:

- Area Scan setting - Find Secondary Maximum Within: 2.0dB and with a peak SAR value greater than 0.5 W/Kg
- Probe: EX3DV4 - SN3977; ConvF(7.69, 7.69, 7.69); Calibrated: 2014/2/17;
- Sensor-Surface: 2mm (Mechanical Surface Detection)
- Electronics: DAE4 Sn779; Calibrated: 2014/2/25
- Phantom: ELI v5.0; Type: QDOVA002AA; Serial: TP:1133
- Measurement SW: DASYS2, Version 52.8 (7); SEMCAD X Version 14.6.10 (7164)

**Flat/Area Scan (81x121x1):**

Interpolated grid: dx=1.500 mm, dy=1.500 mm

Maximum value of SAR (interpolated) = 1.26 W/kg

**Flat/Zoom Scan (5x5x7)/Cube 0:**

Measurement grid: dx=8mm, dy=8mm, dz=5mm

Reference Value = 11.921 V/m; Power Drift = 0.04 dB

Peak SAR (extrapolated) = 1.58 W/kg

**SAR(1 g) = 0.908 W/kg; SAR(10 g) = 0.478 W/kg**

Maximum value of SAR (measured) = 1.27 W/kg

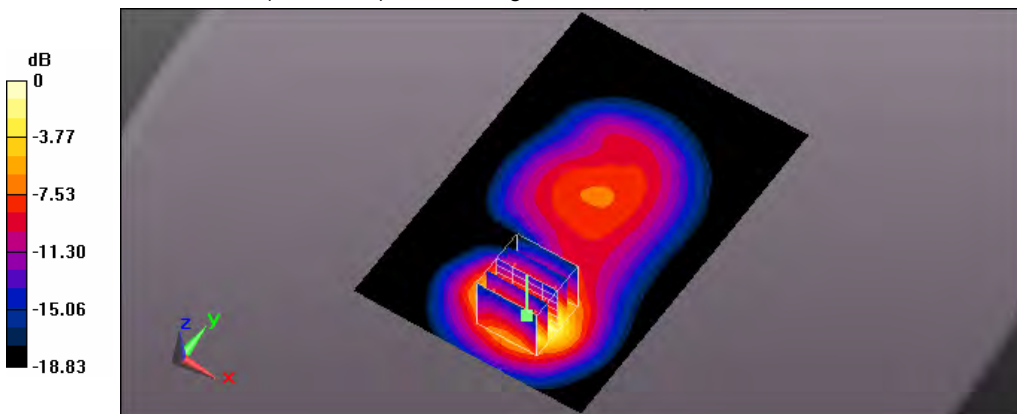

0 dB = 1.27 W/kg = 1.04 dBW/kg

Test Laboratory: A Test Lab Techno Corp.

Date: 2014/11/28 Time: AM 01:54:24

**53\_Flat\_LTE Band4 BW 20M CH20175\_QPSK with 100 RB Size 0 RB Offset side 5 surface to phantom 10mm**

**DUT: AC779S-200; Type: Mobile Hot Spot; Serial: 014260000002034**

Communication System: UID 0, Generic LTE (0); Frequency: 1732.5 MHz; Duty Cycle: 1:1

Medium parameters used (interpolated):  $f = 1732.5$  MHz;  $\sigma = 1.517$  S/m;  $\epsilon_r = 54.32$ ;  $\rho = 1000$  kg/m<sup>3</sup>

Phantom section: Flat Section

Measurement Standard: DASY5 (IEEE/IEC/ANSI C63.19-2011)

DASY Configuration:

- Area Scan setting - Find Secondary Maximum Within: 2.0dB and with a peak SAR value greater than 0.5 W/Kg
- Probe: EX3DV4 - SN3977; ConvF(7.69, 7.69, 7.69); Calibrated: 2014/2/17;
- Sensor-Surface: 2mm (Mechanical Surface Detection)
- Electronics: DAE4 Sn779; Calibrated: 2014/2/25
- Phantom: ELI v5.0; Type: QDOVA002AA; Serial: TP:1133
- Measurement SW: DASY52, Version 52.8 (7); SEMCAD X Version 14.6.10 (7164)

**Flat/Area Scan (61x101x1):**

Interpolated grid: dx=1.500 mm, dy=1.500 mm

Maximum value of SAR (interpolated) = 1.07 W/kg

**Flat/Zoom Scan (5x5x7)/Cube 0:**

Measurement grid: dx=8mm, dy=8mm, dz=5mm

Reference Value = 21.971 V/m; Power Drift = 0.03 dB

Peak SAR (extrapolated) = 1.27 W/kg

**SAR(1 g) = 0.770 W/kg; SAR(10 g) = 0.426 W/kg**

Maximum value of SAR (measured) = 1.02 W/kg

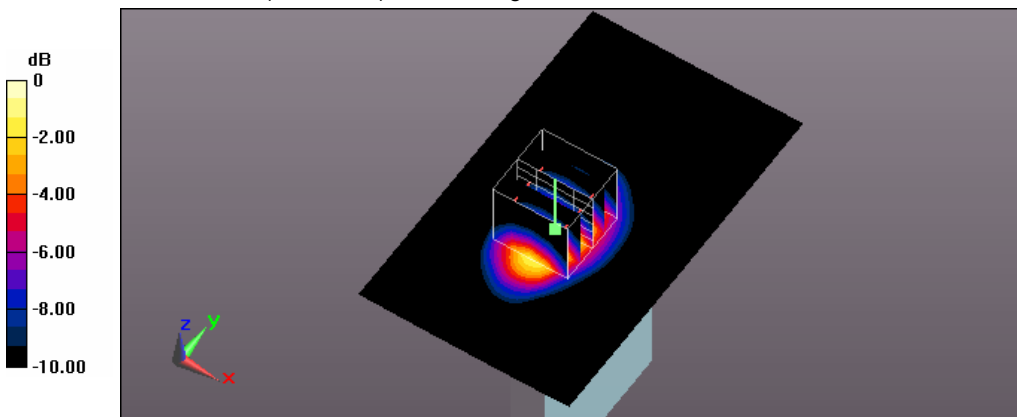

0 dB = 1.02 W/kg = 0.09 dBW/kg

Test Laboratory: A Test Lab Techno Corp.

Date: 2014/11/28 Time: PM 05:06:46

**61\_Flat\_LTE Band5 BW 10M CH20600\_QPSK with 1 RB Size 0 RB Offset side 1 surface to phantom 10mm**

**DUT: AC779S-200; Type: Mobile Hot Spot; Serial: 01426000002034**

Communication System: UID 0, Generic LTE (0); Frequency: 844 MHz; Duty Cycle: 1:1

Medium parameters used:  $f = 844 \text{ MHz}$ ;  $\sigma = 1.002 \text{ S/m}$ ;  $\epsilon_r = 55.307$ ;  $\rho = 1000 \text{ kg/m}^3$

Phantom section: Flat Section

Measurement Standard: DASYS (IEEE/IEC/ANSI C63.19-2011)

DASY Configuration:

- Area Scan setting - Find Secondary Maximum Within: 2.0dB and with a peak SAR value greater than 0.5 W/Kg
- Probe: EX3DV4 - SN3977; ConvF(9.74, 9.74, 9.74); Calibrated: 2014/2/17;
- Sensor-Surface: 2mm (Mechanical Surface Detection)
- Electronics: DAE4 Sn779; Calibrated: 2014/2/25
- Phantom: ELI v5.0; Type: QDOVA002AA; Serial: TP:1133
- Measurement SW: DASYS2, Version 52.8 (7); SEMCAD X Version 14.6.10 (7164)

**Flat/Area Scan (81x121x1):**

Interpolated grid:  $dx=1.500 \text{ mm}$ ,  $dy=1.500 \text{ mm}$

Maximum value of SAR (interpolated) = 0.729 W/kg

**Flat/Zoom Scan (5x5x7)/Cube 0:**

Measurement grid:  $dx=8\text{mm}$ ,  $dy=8\text{mm}$ ,  $dz=5\text{mm}$

Reference Value = 18.433 V/m; Power Drift = 0.04 dB

Peak SAR (extrapolated) = 0.879 W/kg

**SAR(1 g) = 0.607 W/kg; SAR(10 g) = 0.415 W/kg**

Maximum value of SAR (measured) = 0.756 W/kg

**Flat/Zoom Scan (5x5x7)/Cube 1:**

Measurement grid:  $dx=8\text{mm}$ ,  $dy=8\text{mm}$ ,  $dz=5\text{mm}$

Reference Value = 18.433 V/m; Power Drift = 0.04 dB

Peak SAR (extrapolated) = 0.853 W/kg

**SAR(1 g) = 0.495 W/kg; SAR(10 g) = 0.309 W/kg**

Maximum value of SAR (measured) = 0.711 W/kg

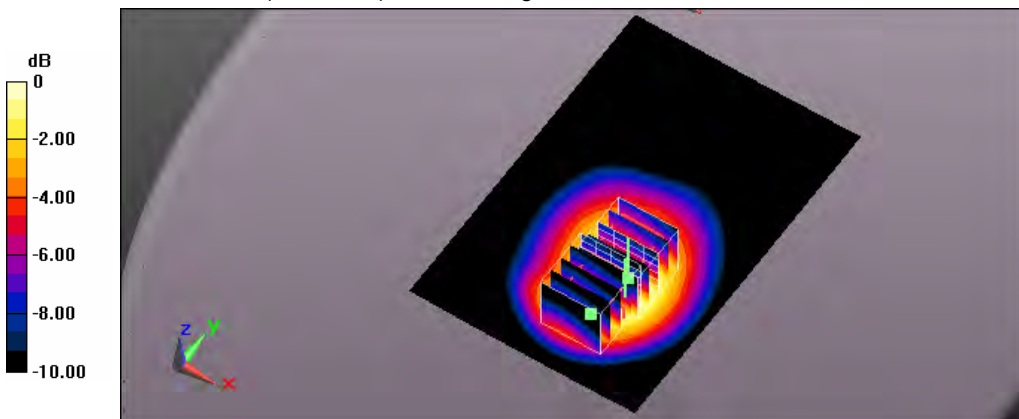

0 dB = 0.711 W/kg = -1.48 dBW/kg



Test Laboratory: A Test Lab Techno Corp.

Date: 2014/11/28 Time: PM 05:41:52

**62\_Flat\_LTE Band5 BW 10M CH20600\_QPSK with 1 RB Size 0 RB Offset side 2 surface to phantom 10mm**

**DUT: AC779S-200; Type: Mobile Hot Spot; Serial: 01426000002034**

Communication System: UID 0, Generic LTE (0); Frequency: 844 MHz; Duty Cycle: 1:1

Medium parameters used:  $f = 844 \text{ MHz}$ ;  $\sigma = 1.002 \text{ S/m}$ ;  $\epsilon_r = 55.307$ ;  $\rho = 1000 \text{ kg/m}^3$

Phantom section: Flat Section

Measurement Standard: DASY5 (IEEE/IEC/ANSI C63.19-2011)

DASY Configuration:

- Area Scan setting - Find Secondary Maximum Within: 2.0dB and with a peak SAR value greater than 0.5 W/Kg
- Probe: EX3DV4 - SN3977; ConvF(9.74, 9.74, 9.74); Calibrated: 2014/2/17;
- Sensor-Surface: 2mm (Mechanical Surface Detection)
- Electronics: DAE4 Sn779; Calibrated: 2014/2/25
- Phantom: ELI v5.0; Type: QDOVA002AA; Serial: TP:1133
- Measurement SW: DASY52, Version 52.8 (7); SEMCAD X Version 14.6.10 (7164)

**Flat/Area Scan (81x121x1):**

Interpolated grid:  $dx=1.500 \text{ mm}$ ,  $dy=1.500 \text{ mm}$

Maximum value of SAR (interpolated) = 0.675 W/kg

**Flat/Zoom Scan (5x5x7)/Cube 0:**

Measurement grid:  $dx=8\text{mm}$ ,  $dy=8\text{mm}$ ,  $dz=5\text{mm}$

Reference Value = 18.341 V/m; Power Drift = 0.08 dB

Peak SAR (extrapolated) = 0.766 W/kg

**SAR(1 g) = 0.552 W/kg; SAR(10 g) = 0.384 W/kg**

Maximum value of SAR (measured) = 0.673 W/kg

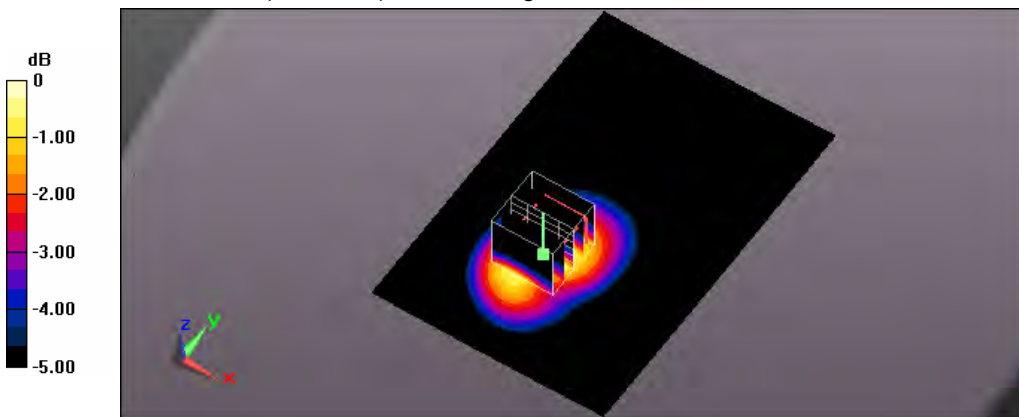

0 dB = 0.673 W/kg = -1.72 dBW/kg

Test Laboratory: A Test Lab Techno Corp.

Date: 2014/11/28 Time: PM 08:06:02

**66\_Flat\_LTE Band5 BW 10M CH20600\_QPSK with 1 RB Size 0 RB Offset side 3 surface to phantom 10mm**

**DUT: AC779S-200; Type: Mobile Hot Spot; Serial: 014260000002034**

Communication System: UID 0, Generic LTE (0); Frequency: 844 MHz; Duty Cycle: 1:1

Medium parameters used:  $f = 844 \text{ MHz}$ ;  $\sigma = 1.002 \text{ S/m}$ ;  $\epsilon_r = 55.307$ ;  $\rho = 1000 \text{ kg/m}^3$

Phantom section: Flat Section

Measurement Standard: DASY5 (IEEE/IEC/ANSI C63.19-2011)

DASY Configuration:

- Area Scan setting - Find Secondary Maximum Within: 2.0dB and with a peak SAR value greater than 0.5 W/Kg
- Probe: EX3DV4 - SN3977; ConvF(9.74, 9.74, 9.74); Calibrated: 2014/2/17;
- Sensor-Surface: 2mm (Mechanical Surface Detection)
- Electronics: DAE4 Sn779; Calibrated: 2014/2/25
- Phantom: ELI v5.0; Type: QDOVA002AA; Serial: TP:1133
- Measurement SW: DASY52, Version 52.8 (7); SEMCAD X Version 14.6.10 (7164)

**Flat/Area Scan (61x111x1):**

Interpolated grid:  $dx=1.500 \text{ mm}$ ,  $dy=1.500 \text{ mm}$

Maximum value of SAR (interpolated) = 0.272 W/kg

**Flat/Zoom Scan (5x5x7)/Cube 0:**

Measurement grid:  $dx=8\text{mm}$ ,  $dy=8\text{mm}$ ,  $dz=5\text{mm}$

Reference Value = 13.919 V/m; Power Drift = -0.14 dB

Peak SAR (extrapolated) = 0.302 W/kg

**SAR(1 g) = 0.225 W/kg; SAR(10 g) = 0.159 W/kg**

Maximum value of SAR (measured) = 0.267 W/kg

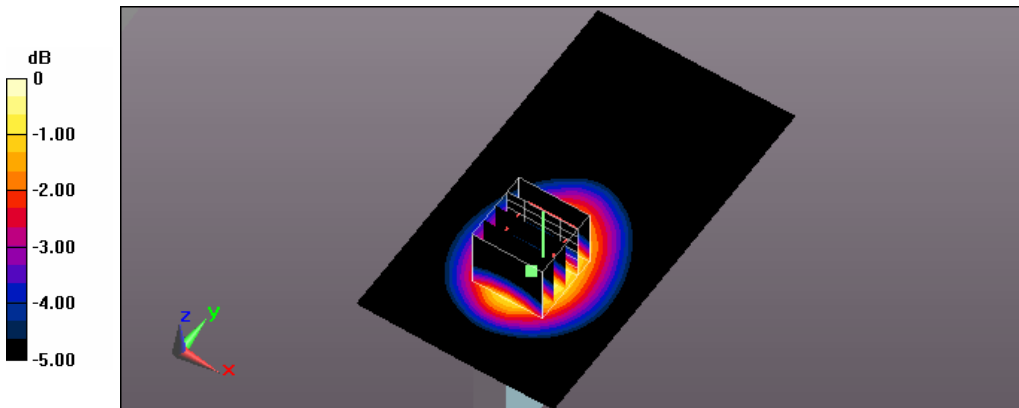

0 dB = 0.267 W/kg = -5.73 dBW/kg

Test Laboratory: A Test Lab Techno Corp.

Date: 2014/11/28 Time: PM 08:25:14

**67\_Flat\_LTE Band5 BW 10M CH20600\_QPSK with 1 RB Size 0 RB Offset side 4 surface to phantom 10mm**

**DUT: AC779S-200; Type: Mobile Hot Spot; Serial: 01426000002034**

Communication System: UID 0, Generic LTE (0); Frequency: 844 MHz; Duty Cycle: 1:1

Medium parameters used:  $f = 844 \text{ MHz}$ ;  $\sigma = 1.002 \text{ S/m}$ ;  $\epsilon_r = 55.307$ ;  $\rho = 1000 \text{ kg/m}^3$

Phantom section: Flat Section

Measurement Standard: DASY5 (IEEE/IEC/ANSI C63.19-2011)

DASY Configuration:

- Area Scan setting - Find Secondary Maximum Within: 2.0dB and with a peak SAR value greater than 0.5 W/Kg
- Probe: EX3DV4 - SN3977; ConvF(9.74, 9.74, 9.74); Calibrated: 2014/2/17;
- Sensor-Surface: 2mm (Mechanical Surface Detection)
- Electronics: DAE4 Sn779; Calibrated: 2014/2/25
- Phantom: ELI v5.0; Type: QDOVA002AA; Serial: TP:1133
- Measurement SW: DASY52, Version 52.8 (7); SEMCAD X Version 14.6.10 (7164)

**Flat/Area Scan (61x111x1):**

Interpolated grid:  $dx=1.500 \text{ mm}$ ,  $dy=1.500 \text{ mm}$

Maximum value of SAR (interpolated) = 0.274 W/kg

**Flat/Zoom Scan (5x5x7)/Cube 0:**

Measurement grid:  $dx=8\text{mm}$ ,  $dy=8\text{mm}$ ,  $dz=5\text{mm}$

Reference Value = 16.108 V/m; Power Drift = 0.03 dB

Peak SAR (extrapolated) = 0.316 W/kg

**SAR(1 g) = 0.221 W/kg; SAR(10 g) = 0.148 W/kg**

Maximum value of SAR (measured) = 0.274 W/kg

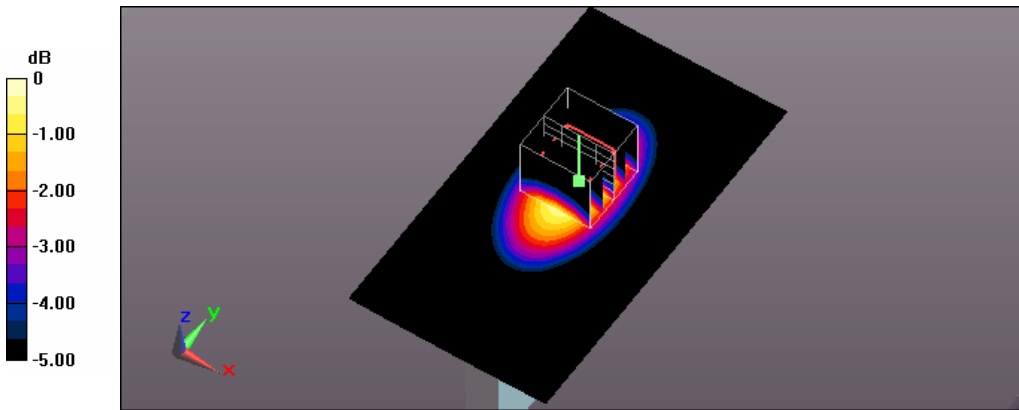

0 dB = 0.274 W/kg = -5.62 dBW/kg

Test Laboratory: A Test Lab Techno Corp.

Date: 2014/11/28 Time: PM 09:19:22

**70\_Flat\_LTE Band5 BW 10M CH20600\_QPSK with 1 RB Size 0 RB Offset side 5 surface to phantom 10mm**

**DUT: AC779S-200; Type: Mobile Hot Spot; Serial: 01426000002034**

Communication System: UID 0, Generic LTE (0); Frequency: 844 MHz; Duty Cycle: 1:1

Medium parameters used:  $f = 844 \text{ MHz}$ ;  $\sigma = 1.002 \text{ S/m}$ ;  $\epsilon_r = 55.307$ ;  $\rho = 1000 \text{ kg/m}^3$

Phantom section: Flat Section

Measurement Standard: DASY5 (IEEE/IEC/ANSI C63.19-2011)

DASY Configuration:

- Area Scan setting - Find Secondary Maximum Within: 2.0dB and with a peak SAR value greater than 0.5 W/Kg
- Probe: EX3DV4 - SN3977; ConvF(9.74, 9.74, 9.74); Calibrated: 2014/2/17;
- Sensor-Surface: 2mm (Mechanical Surface Detection)
- Electronics: DAE4 Sn779; Calibrated: 2014/2/25
- Phantom: ELI v5.0; Type: QDOVA002AA; Serial: TP:1133
- Measurement SW: DASY52, Version 52.8 (7); SEMCAD X Version 14.6.10 (7164)

**Flat/Area Scan (61x101x1):**

Interpolated grid:  $dx=1.500 \text{ mm}$ ,  $dy=1.500 \text{ mm}$

Maximum value of SAR (interpolated) = 0.171 W/kg

**Flat/Zoom Scan (5x5x7)/Cube 0:**

Measurement grid:  $dx=8\text{mm}$ ,  $dy=8\text{mm}$ ,  $dz=5\text{mm}$

Reference Value = 11.875 V/m; Power Drift = -0.17 dB

Peak SAR (extrapolated) = 0.210 W/kg

**SAR(1 g) = 0.128 W/kg; SAR(10 g) = 0.076 W/kg**

Maximum value of SAR (measured) = 0.172 W/kg

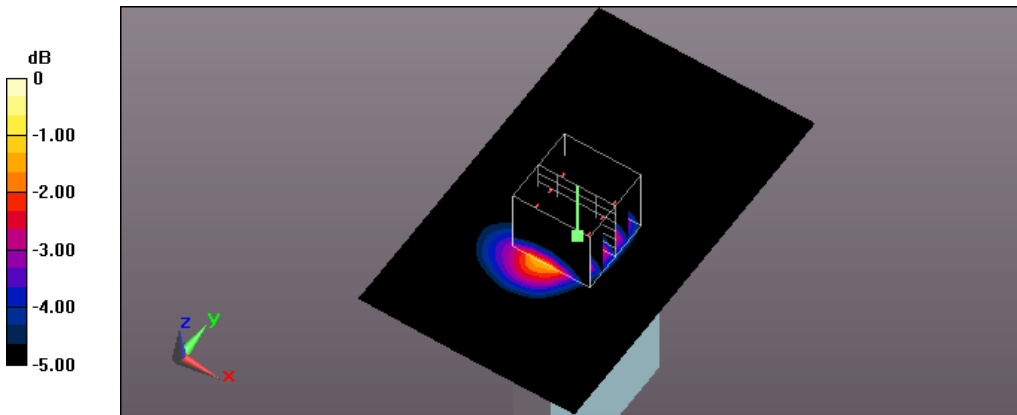

0 dB = 0.172 W/kg = -7.64 dBW/kg

Test Laboratory: A Test Lab Techno Corp.

Date: 2014/11/28 Time: PM 07:25:21

**64\_Flat\_LTE Band5 BW 10M CH20600\_QPSK with 25 RB Size 0 RB Offset side 1 surface to phantom 10mm**

**DUT: AC779S-200; Type: Mobile Hot Spot; Serial: 01426000002034**

Communication System: UID 0, Generic LTE (0); Frequency: 844 MHz; Duty Cycle: 1:1

Medium parameters used:  $f = 844 \text{ MHz}$ ;  $\sigma = 1.002 \text{ S/m}$ ;  $\epsilon_r = 55.307$ ;  $\rho = 1000 \text{ kg/m}^3$

Phantom section: Flat Section

Measurement Standard: DASY5 (IEEE/IEC/ANSI C63.19-2011)

DASY Configuration:

- Area Scan setting - Find Secondary Maximum Within: 2.0dB and with a peak SAR value greater than 0.5 W/Kg
- Probe: EX3DV4 - SN3977; ConvF(9.74, 9.74, 9.74); Calibrated: 2014/2/17;
- Sensor-Surface: 2mm (Mechanical Surface Detection)
- Electronics: DAE4 Sn779; Calibrated: 2014/2/25
- Phantom: ELI v5.0; Type: QDOVA002AA; Serial: TP:1133
- Measurement SW: DASY52, Version 52.8 (7); SEMCAD X Version 14.6.10 (7164)

**Flat/Area Scan (81x121x1):**

Interpolated grid:  $dx=1.500 \text{ mm}$ ,  $dy=1.500 \text{ mm}$

Maximum value of SAR (interpolated) = 0.641 W/kg

**Flat/Zoom Scan (5x5x7)/Cube 0:**

Measurement grid:  $dx=8\text{mm}$ ,  $dy=8\text{mm}$ ,  $dz=5\text{mm}$

Reference Value = 18.329 V/m; Power Drift = -0.04 dB

Peak SAR (extrapolated) = 0.739 W/kg

**SAR(1 g) = 0.511 W/kg; SAR(10 g) = 0.347 W/kg**

Maximum value of SAR (measured) = 0.636 W/kg

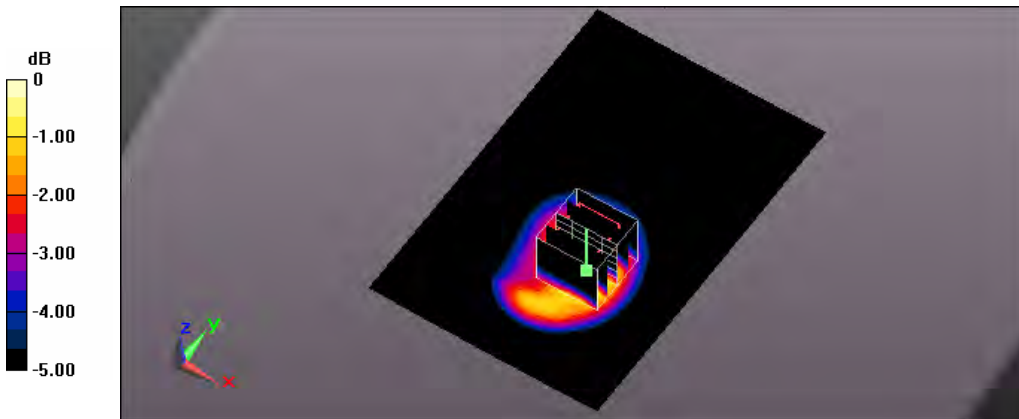

0 dB = 0.636 W/kg = -1.97 dBW/kg

Test Laboratory: A Test Lab Techno Corp.

Date: 2014/11/28 Time: PM 06:05:01

**63\_Flat\_LTE Band5 BW 10M CH20600\_QPSK with 25 RB Size 0 RB Offset side 2 surface to phantom 10mm**

**DUT: AC779S-200; Type: Mobile Hot Spot; Serial: 01426000002034**

Communication System: UID 0, Generic LTE (0); Frequency: 844 MHz; Duty Cycle: 1:1

Medium parameters used:  $f = 844 \text{ MHz}$ ;  $\sigma = 1.002 \text{ S/m}$ ;  $\epsilon_r = 55.307$ ;  $\rho = 1000 \text{ kg/m}^3$

Phantom section: Flat Section

Measurement Standard: DASYS (IEEE/IEC/ANSI C63.19-2011)

DASY Configuration:

- Area Scan setting - Find Secondary Maximum Within: 2.0dB and with a peak SAR value greater than 0.5 W/Kg
- Probe: EX3DV4 - SN3977; ConvF(9.74, 9.74, 9.74); Calibrated: 2014/2/17;
- Sensor-Surface: 2mm (Mechanical Surface Detection)
- Electronics: DAE4 Sn779; Calibrated: 2014/2/25
- Phantom: ELI v5.0; Type: QDOVA002AA; Serial: TP:1133
- Measurement SW: DASYS2, Version 52.8 (7); SEMCAD X Version 14.6.10 (7164)

**Flat/Area Scan (81x121x1):**

Interpolated grid:  $dx=1.500 \text{ mm}$ ,  $dy=1.500 \text{ mm}$

Maximum value of SAR (interpolated) = 0.542 W/kg

**Flat/Zoom Scan (5x5x7)/Cube 0:**

Measurement grid:  $dx=8\text{mm}$ ,  $dy=8\text{mm}$ ,  $dz=5\text{mm}$

Reference Value = 16.866 V/m; Power Drift = 0.01 dB

Peak SAR (extrapolated) = 0.623 W/kg

**SAR(1 g) = 0.444 W/kg; SAR(10 g) = 0.309 W/kg**

Maximum value of SAR (measured) = 0.542 W/kg

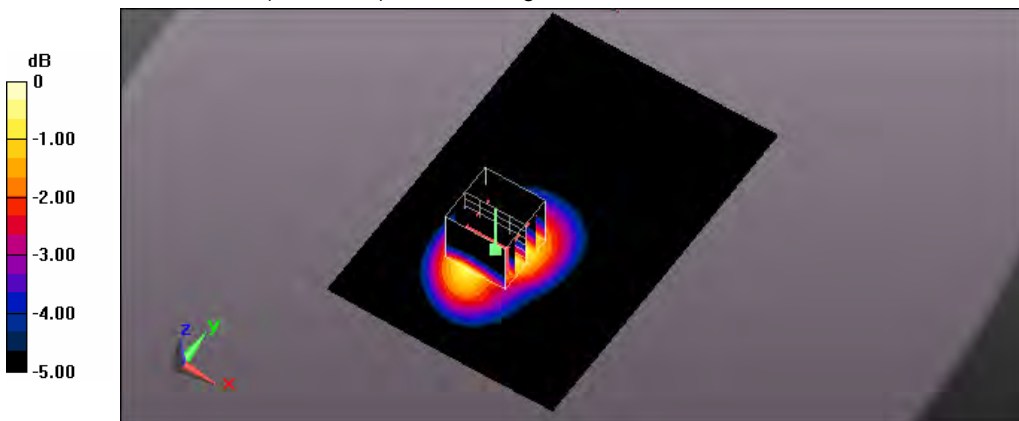

0 dB = 0.542 W/kg = -2.66 dBW/kg

Test Laboratory: A Test Lab Techno Corp.

Date: 2014/11/28 Time: PM 07:48:18

**65\_Flat\_LTE Band5 BW 10M CH20600\_QPSK with 25 RB Size 0 RB Offset side 3 surface to phantom 10mm**

**DUT: AC779S-200; Type: Mobile Hot Spot; Serial: 01426000002034**

Communication System: UID 0, Generic LTE (0); Frequency: 844 MHz; Duty Cycle: 1:1

Medium parameters used:  $f = 844 \text{ MHz}$ ;  $\sigma = 1.002 \text{ S/m}$ ;  $\epsilon_r = 55.307$ ;  $\rho = 1000 \text{ kg/m}^3$

Phantom section: Flat Section

Measurement Standard: DASYS (IEEE/IEC/ANSI C63.19-2011)

DASY Configuration:

- Area Scan setting - Find Secondary Maximum Within: 2.0dB and with a peak SAR value greater than 0.5 W/Kg
- Probe: EX3DV4 - SN3977; ConvF(9.74, 9.74, 9.74); Calibrated: 2014/2/17;
- Sensor-Surface: 2mm (Mechanical Surface Detection)
- Electronics: DAE4 Sn779; Calibrated: 2014/2/25
- Phantom: ELI v5.0; Type: QDOVA002AA; Serial: TP:1133
- Measurement SW: DASYS2, Version 52.8 (7); SEMCAD X Version 14.6.10 (7164)

**Flat/Area Scan (61x111x1):**

Interpolated grid:  $dx=1.500 \text{ mm}$ ,  $dy=1.500 \text{ mm}$

Maximum value of SAR (interpolated) = 0.226 W/kg

**Flat/Zoom Scan (5x5x7)/Cube 0:**

Measurement grid:  $dx=8\text{mm}$ ,  $dy=8\text{mm}$ ,  $dz=5\text{mm}$

Reference Value = 12.866 V/m; Power Drift = -0.02 dB

Peak SAR (extrapolated) = 0.243 W/kg

**SAR(1 g) = 0.179 W/kg; SAR(10 g) = 0.127 W/kg**

Maximum value of SAR (measured) = 0.214 W/kg

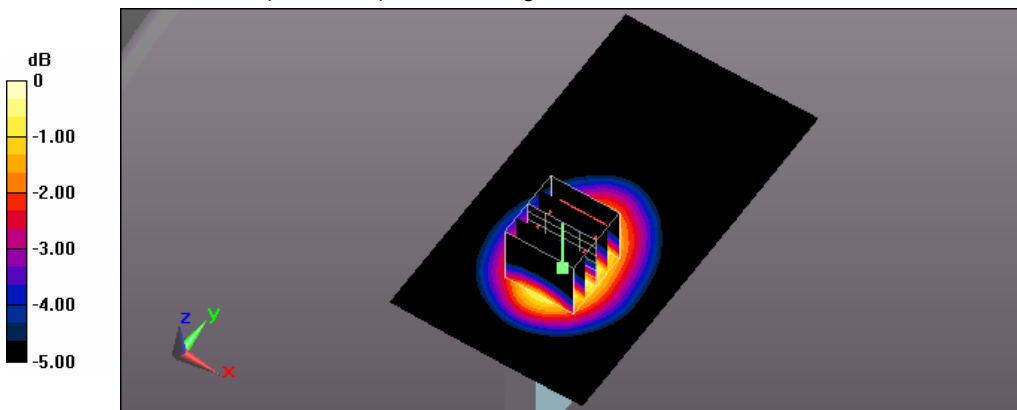

0 dB = 0.214 W/kg = -6.70 dBW/kg

Test Laboratory: A Test Lab Techno Corp.

Date: 2014/11/28 Time: PM 08:43:14

**68\_Flat\_LTE Band5 BW 10M CH20600\_QPSK with 25 RB Size 0 RB Offset side 4 surface to phantom 10mm**

**DUT: AC779S-200; Type: Mobile Hot Spot; Serial: 01426000002034**

Communication System: UID 0, Generic LTE (0); Frequency: 844 MHz; Duty Cycle: 1:1

Medium parameters used:  $f = 844 \text{ MHz}$ ;  $\sigma = 1.002 \text{ S/m}$ ;  $\epsilon_r = 55.307$ ;  $\rho = 1000 \text{ kg/m}^3$

Phantom section: Flat Section

Measurement Standard: DASY5 (IEEE/IEC/ANSI C63.19-2011)

DASY Configuration:

- Area Scan setting - Find Secondary Maximum Within: 2.0dB and with a peak SAR value greater than 0.5 W/Kg
- Probe: EX3DV4 - SN3977; ConvF(9.74, 9.74, 9.74); Calibrated: 2014/2/17;
- Sensor-Surface: 2mm (Mechanical Surface Detection)
- Electronics: DAE4 Sn779; Calibrated: 2014/2/25
- Phantom: ELI v5.0; Type: QDOVA002AA; Serial: TP:1133
- Measurement SW: DASY52, Version 52.8 (7); SEMCAD X Version 14.6.10 (7164)

**Flat/Area Scan (61x111x1):**

Interpolated grid:  $dx=1.500 \text{ mm}$ ,  $dy=1.500 \text{ mm}$

Maximum value of SAR (interpolated) = 0.220 W/kg

**Flat/Zoom Scan (5x5x7)/Cube 0:**

Measurement grid:  $dx=8\text{mm}$ ,  $dy=8\text{mm}$ ,  $dz=5\text{mm}$

Reference Value = 14.604 V/m; Power Drift = 0.01 dB

Peak SAR (extrapolated) = 0.254 W/kg

**SAR(1 g) = 0.176 W/kg; SAR(10 g) = 0.118 W/kg**

Maximum value of SAR (measured) = 0.219 W/kg

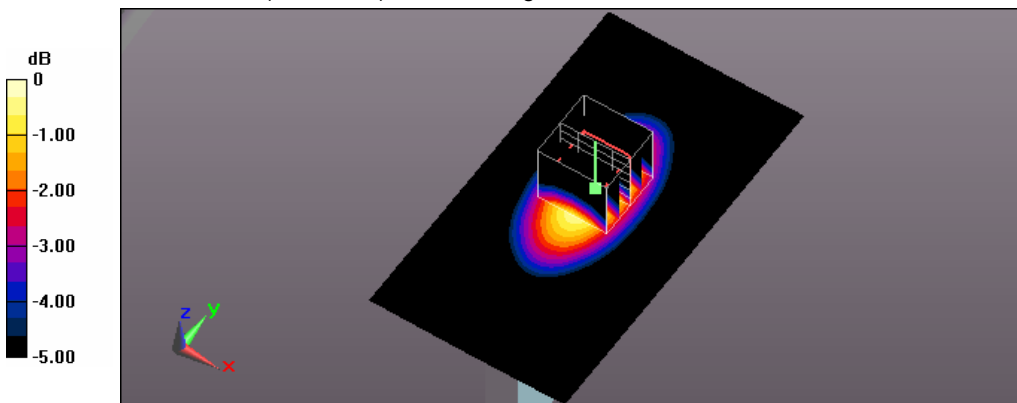

0 dB = 0.219 W/kg = -6.60 dBW/kg



Test Laboratory: A Test Lab Techno Corp.

Date: 2014/11/28 Time: PM 09:02:56

**69\_Flat\_LTE Band5 BW 10M CH20600\_QPSK with 25 RB Size 0 RB Offset side 5 surface to phantom 10mm**

**DUT: AC779S-200; Type: Mobile Hot Spot; Serial: 01426000002034**

Communication System: UID 0, Generic LTE (0); Frequency: 844 MHz; Duty Cycle: 1:1

Medium parameters used:  $f = 844 \text{ MHz}$ ;  $\sigma = 1.002 \text{ S/m}$ ;  $\epsilon_r = 55.307$ ;  $\rho = 1000 \text{ kg/m}^3$

Phantom section: Flat Section

Measurement Standard: DASYS (IEEE/IEC/ANSI C63.19-2011)

DASY Configuration:

- Area Scan setting - Find Secondary Maximum Within: 2.0dB and with a peak SAR value greater than 0.5 W/Kg
- Probe: EX3DV4 - SN3977; ConvF(9.74, 9.74, 9.74); Calibrated: 2014/2/17;
- Sensor-Surface: 2mm (Mechanical Surface Detection)
- Electronics: DAE4 Sn779; Calibrated: 2014/2/25
- Phantom: ELI v5.0; Type: QDOVA002AA; Serial: TP:1133
- Measurement SW: DASYS2, Version 52.8 (7); SEMCAD X Version 14.6.10 (7164)

**Flat/Area Scan (61x101x1):**

Interpolated grid:  $dx=1.500 \text{ mm}$ ,  $dy=1.500 \text{ mm}$

Maximum value of SAR (interpolated) = 0.136 W/kg

**Flat/Zoom Scan (5x5x7)/Cube 0:**

Measurement grid:  $dx=8\text{mm}$ ,  $dy=8\text{mm}$ ,  $dz=5\text{mm}$

Reference Value = 10.529 V/m; Power Drift = -0.12 dB

Peak SAR (extrapolated) = 0.167 W/kg

**SAR(1 g) = 0.101 W/kg; SAR(10 g) = 0.060 W/kg**

Maximum value of SAR (measured) = 0.137 W/kg

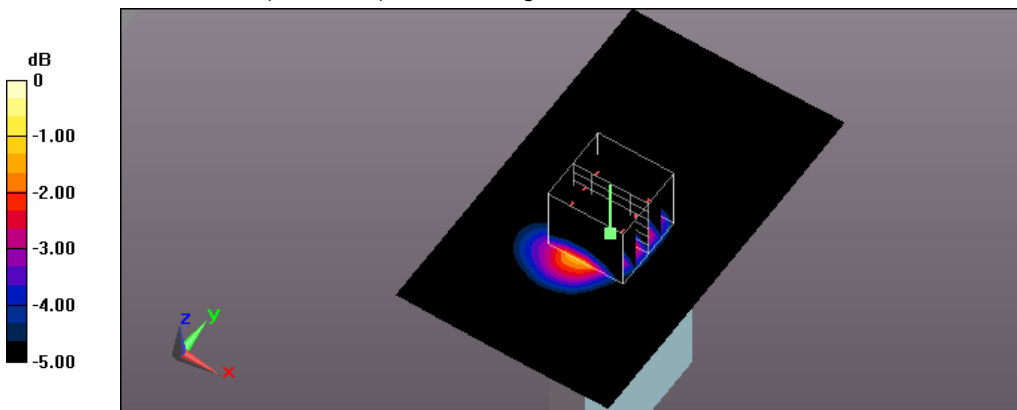

0 dB = 0.137 W/kg = -8.63 dBW/kg

Test Laboratory: A Test Lab Techno Corp.

Date: 2014/12/1 Time: PM 02:18:18

**71\_Flat\_LTE Band17 BW 10M CH23780\_QPSK with 1 RB Size 0 RB Offset side 1 surface to phantom 10mm**

**DUT: AC779S-200; Type: Mobile Hot Spot; Serial: 01426000002034**

Communication System: UID 0, Generic LTE (0); Frequency: 709 MHz; Duty Cycle: 1:1

Medium parameters used:  $f = 709 \text{ MHz}$ ;  $\sigma = 0.94 \text{ S/m}$ ;  $\epsilon_r = 53.708$ ;  $\rho = 1000 \text{ kg/m}^3$

Phantom section: Flat Section

Measurement Standard: DASY5 (IEEE/IEC/ANSI C63.19-2011)

DASY Configuration:

- Area Scan setting - Find Secondary Maximum Within: 2.0dB and with a peak SAR value greater than 0.5 W/Kg
- Probe: EX3DV4 - SN3977; ConvF(9.78, 9.78, 9.78); Calibrated: 2014/2/17;
- Sensor-Surface: 2mm (Mechanical Surface Detection)
- Electronics: DAE4 Sn779; Calibrated: 2014/2/25
- Phantom: ELI v5.0; Type: QDOVA002AA; Serial: TP:1133
- Measurement SW: DASY52, Version 52.8 (7); SEMCAD X Version 14.6.10 (7164)

**Flat/Area Scan (81x121x1):**

Interpolated grid:  $dx=1.500 \text{ mm}$ ,  $dy=1.500 \text{ mm}$

Maximum value of SAR (interpolated) = 1.37 W/kg

**Flat/Zoom Scan (5x5x7)/Cube 0:**

Measurement grid:  $dx=8\text{mm}$ ,  $dy=8\text{mm}$ ,  $dz=5\text{mm}$

Reference Value = 33.636 V/m; Power Drift = -0.06 dB

Peak SAR (extrapolated) = 1.58 W/kg

**SAR(1 g) = 1.13 W/kg; SAR(10 g) = 0.793 W/kg**

Maximum value of SAR (measured) = 1.34 W/kg

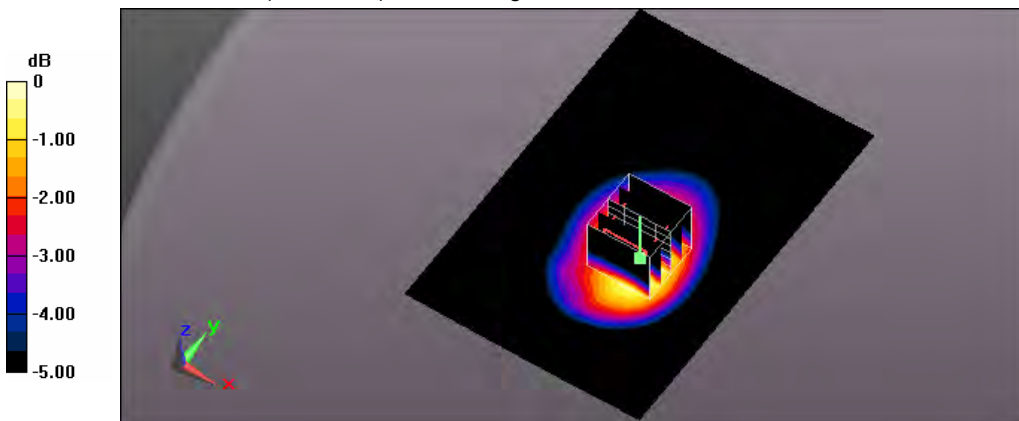

0 dB = 1.34 W/kg = 1.27 dBW/kg

Test Laboratory: A Test Lab Techno Corp.

Date: 2014/12/1 Time: PM 05:04:23

**78\_Flat\_LTE Band17 BW 10M CH23780\_QPSK with 1 RB Size 0 RB Offset side 2 surface to phantom 10mm**

**DUT: AC779S-200; Type: Mobile Hot Spot; Serial: 01426000002034**

Communication System: UID 0, Generic LTE (0); Frequency: 709 MHz; Duty Cycle: 1:1

Medium parameters used:  $f = 709 \text{ MHz}$ ;  $\sigma = 0.94 \text{ S/m}$ ;  $\epsilon_r = 53.708$ ;  $\rho = 1000 \text{ kg/m}^3$

Phantom section: Flat Section

Measurement Standard: DASYS (IEEE/IEC/ANSI C63.19-2011)

DASY Configuration:

- Area Scan setting - Find Secondary Maximum Within: 2.0dB and with a peak SAR value greater than 0.5 W/Kg
- Probe: EX3DV4 - SN3977; ConvF(9.78, 9.78, 9.78); Calibrated: 2014/2/17;
- Sensor-Surface: 2mm (Mechanical Surface Detection)
- Electronics: DAE4 Sn779; Calibrated: 2014/2/25
- Phantom: ELI v5.0; Type: QDOVA002AA; Serial: TP:1133
- Measurement SW: DASYS2, Version 52.8 (7); SEMCAD X Version 14.6.10 (7164)

**Flat/Area Scan (81x121x1):**

Interpolated grid:  $dx=1.500 \text{ mm}$ ,  $dy=1.500 \text{ mm}$

Maximum value of SAR (interpolated) = 1.32 W/kg

**Flat/Zoom Scan (5x5x7)/Cube 0:**

Measurement grid:  $dx=8\text{mm}$ ,  $dy=8\text{mm}$ ,  $dz=5\text{mm}$

Reference Value = 30.259 V/m; Power Drift = -0.03 dB

Peak SAR (extrapolated) = 1.53 W/kg

**SAR(1 g) = 1.07 W/kg; SAR(10 g) = 0.752 W/kg**

Maximum value of SAR (measured) = 1.31 W/kg

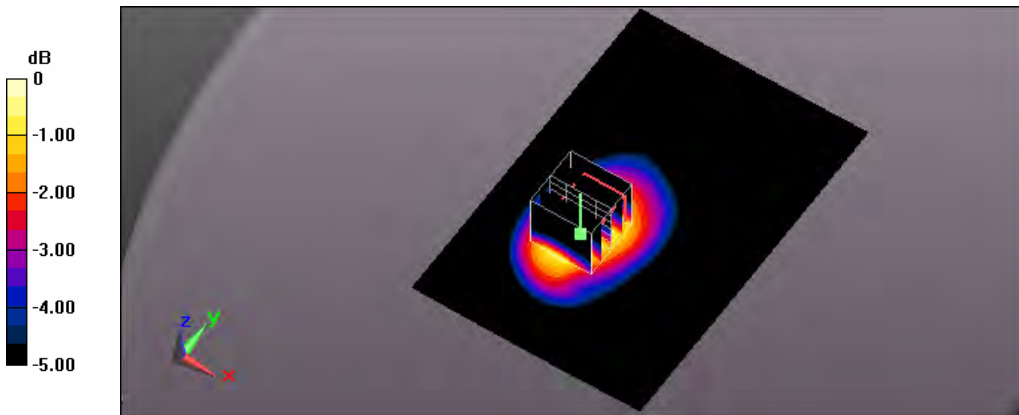

0 dB = 1.31 W/kg = 1.17 dBW/kg

Test Laboratory: A Test Lab Techno Corp.

Date: 2014/12/1 Time: PM 08:11:51

**86\_Flat\_LTE Band17 BW 10M CH23780\_QPSK with 1 RB Size 0 RB Offset side 3 surface to phantom 10mm**

**DUT: AC779S-200; Type: Mobile Hot Spot; Serial: 01426000002034**

Communication System: UID 0, Generic LTE (0); Frequency: 709 MHz; Duty Cycle: 1:1

Medium parameters used:  $f = 709 \text{ MHz}$ ;  $\sigma = 0.94 \text{ S/m}$ ;  $\epsilon_r = 53.708$ ;  $\rho = 1000 \text{ kg/m}^3$

Phantom section: Flat Section

Measurement Standard: DASY5 (IEEE/IEC/ANSI C63.19-2011)

DASY Configuration:

- Area Scan setting - Find Secondary Maximum Within: 2.0dB and with a peak SAR value greater than 0.5 W/Kg
- Probe: EX3DV4 - SN3977; ConvF(9.78, 9.78, 9.78); Calibrated: 2014/2/17;
- Sensor-Surface: 2mm (Mechanical Surface Detection)
- Electronics: DAE4 Sn779; Calibrated: 2014/2/25
- Phantom: ELI v5.0; Type: QDOVA002AA; Serial: TP:1133
- Measurement SW: DASY52, Version 52.8 (7); SEMCAD X Version 14.6.10 (7164)

**Flat/Area Scan (61x111x1):**

Interpolated grid:  $dx=1.500 \text{ mm}$ ,  $dy=1.500 \text{ mm}$

Maximum value of SAR (interpolated) = 0.448 W/kg

**Flat/Zoom Scan (5x5x7)/Cube 0:**

Measurement grid:  $dx=8\text{mm}$ ,  $dy=8\text{mm}$ ,  $dz=5\text{mm}$

Reference Value = 20.988 V/m; Power Drift = -0.04 dB

Peak SAR (extrapolated) = 0.499 W/kg

**SAR(1 g) = 0.373 W/kg; SAR(10 g) = 0.269 W/kg**

Maximum value of SAR (measured) = 0.445 W/kg

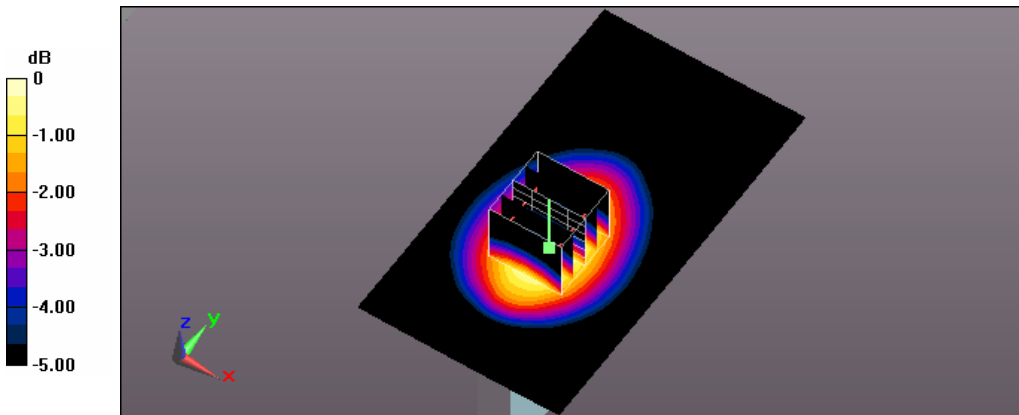

0 dB = 0.445 W/kg = -3.52 dBW/kg

Test Laboratory: A Test Lab Techno Corp.

Date: 2014/12/1 Time: PM 08:31:18

**87\_Flat\_LTE Band17 BW 10M CH23780\_QPSK with 1 RB Size 0 RB Offset side 4 surface to phantom 10mm**

**DUT: AC779S-200; Type: Mobile Hot Spot; Serial: 01426000002034**

Communication System: UID 0, Generic LTE (0); Frequency: 709 MHz; Duty Cycle: 1:1

Medium parameters used:  $f = 709 \text{ MHz}$ ;  $\sigma = 0.94 \text{ S/m}$ ;  $\epsilon_r = 53.708$ ;  $\rho = 1000 \text{ kg/m}^3$

Phantom section: Flat Section

Measurement Standard: DASYS (IEEE/IEC/ANSI C63.19-2011)

DASY Configuration:

- Area Scan setting - Find Secondary Maximum Within: 2.0dB and with a peak SAR value greater than 0.5 W/Kg
- Probe: EX3DV4 - SN3977; ConvF(9.78, 9.78, 9.78); Calibrated: 2014/2/17;
- Sensor-Surface: 2mm (Mechanical Surface Detection)
- Electronics: DAE4 Sn779; Calibrated: 2014/2/25
- Phantom: ELI v5.0; Type: QDOVA002AA; Serial: TP:1133
- Measurement SW: DASYS2, Version 52.8 (7); SEMCAD X Version 14.6.10 (7164)

**Flat/Area Scan (61x111x1):**

Interpolated grid:  $dx=1.500 \text{ mm}$ ,  $dy=1.500 \text{ mm}$

Maximum value of SAR (interpolated) = 0.726 W/kg

**Flat/Zoom Scan (5x5x7)/Cube 0:**

Measurement grid:  $dx=8\text{mm}$ ,  $dy=8\text{mm}$ ,  $dz=5\text{mm}$

Reference Value = 26.121 V/m; Power Drift = 0.02 dB

Peak SAR (extrapolated) = 0.823 W/kg

**SAR(1 g) = 0.584 W/kg; SAR(10 g) = 0.399 W/kg**

Maximum value of SAR (measured) = 0.717 W/kg

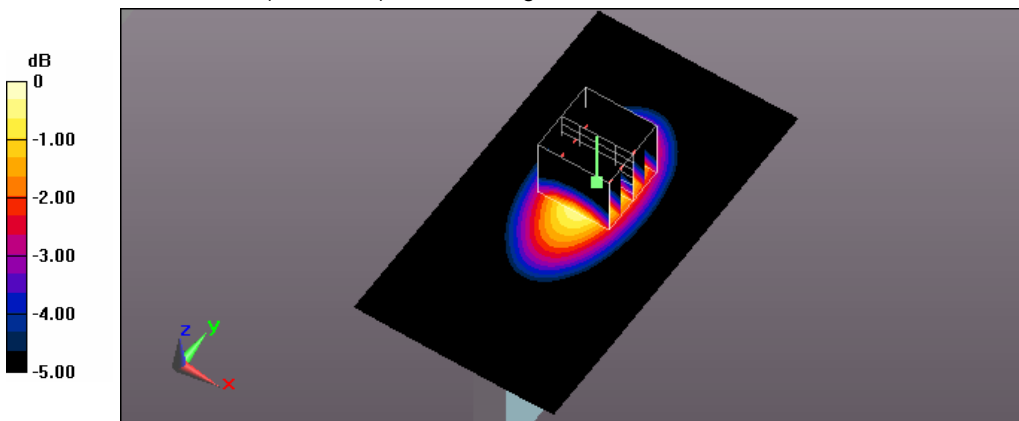

0 dB = 0.717 W/kg = -1.44 dBW/kg

Test Laboratory: A Test Lab Techno Corp.

Date: 2014/12/1 Time: PM 09:45:08

**90\_Flat\_LTE Band17 BW 10M CH23780\_QPSK with 1 RB Size 0 RB Offset side 5 surface to phantom 10mm**

**DUT: AC779S-200; Type: Mobile Hot Spot; Serial: 01426000002034**

Communication System: UID 0, Generic LTE (0); Frequency: 709 MHz; Duty Cycle: 1:1

Medium parameters used:  $f = 709 \text{ MHz}$ ;  $\sigma = 0.94 \text{ S/m}$ ;  $\epsilon_r = 53.708$ ;  $\rho = 1000 \text{ kg/m}^3$

Phantom section: Flat Section

Measurement Standard: DASY5 (IEEE/IEC/ANSI C63.19-2011)

DASY Configuration:

- Area Scan setting - Find Secondary Maximum Within: 2.0dB and with a peak SAR value greater than 0.5 W/Kg
- Probe: EX3DV4 - SN3977; ConvF(9.78, 9.78, 9.78); Calibrated: 2014/2/17;
- Sensor-Surface: 2mm (Mechanical Surface Detection)
- Electronics: DAE4 Sn779; Calibrated: 2014/2/25
- Phantom: ELI v5.0; Type: QDOVA002AA; Serial: TP:1133
- Measurement SW: DASY52, Version 52.8 (7); SEMCAD X Version 14.6.10 (7164)

**Flat/Area Scan (61x101x1):**

Interpolated grid:  $dx=1.500 \text{ mm}$ ,  $dy=1.500 \text{ mm}$

Maximum value of SAR (interpolated) = 0.176 W/kg

**Flat/Zoom Scan (5x5x7)/Cube 0:**

Measurement grid:  $dx=8\text{mm}$ ,  $dy=8\text{mm}$ ,  $dz=5\text{mm}$

Reference Value = 13.886 V/m; Power Drift = 0.10 dB

Peak SAR (extrapolated) = 0.229 W/kg

**SAR(1 g) = 0.133 W/kg; SAR(10 g) = 0.080 W/kg**

Maximum value of SAR (measured) = 0.182 W/kg

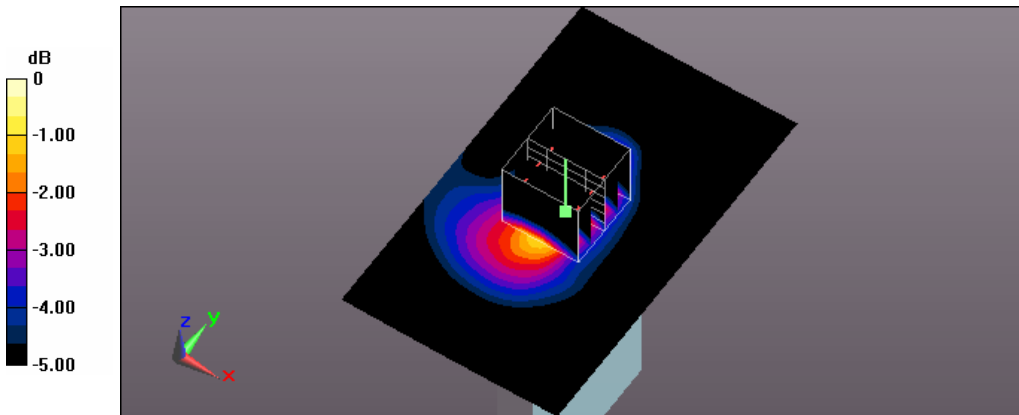

0 dB = 0.182 W/kg = -7.40 dBW/kg

Test Laboratory: A Test Lab Techno Corp.

Date: 2014/12/1 Time: PM 02:45:11

**72\_Flat\_LTE Band17 BW 10M CH23790\_QPSK with 1 RB Size 0 RB Offset side 1 surface to phantom 10mm**

**DUT: AC779S-200; Type: Mobile Hot Spot; Serial: 01426000002034**

Communication System: UID 0, Generic LTE (0); Frequency: 710 MHz; Duty Cycle: 1:1

Medium parameters used:  $f = 710 \text{ MHz}$ ;  $\sigma = 0.942 \text{ S/m}$ ;  $\epsilon_r = 53.665$ ;  $\rho = 1000 \text{ kg/m}^3$

Phantom section: Flat Section

Measurement Standard: DASY5 (IEEE/IEC/ANSI C63.19-2011)

DASY Configuration:

- Area Scan setting - Find Secondary Maximum Within: 2.0dB and with a peak SAR value greater than 0.5 W/Kg
- Probe: EX3DV4 - SN3977; ConvF(9.78, 9.78, 9.78); Calibrated: 2014/2/17;
- Sensor-Surface: 2mm (Mechanical Surface Detection)
- Electronics: DAE4 Sn779; Calibrated: 2014/2/25
- Phantom: ELI v5.0; Type: QDOVA002AA; Serial: TP:1133
- Measurement SW: DASY52, Version 52.8 (7); SEMCAD X Version 14.6.10 (7164)

**Flat/Area Scan (81x121x1):**

Interpolated grid:  $dx=1.500 \text{ mm}$ ,  $dy=1.500 \text{ mm}$

Maximum value of SAR (interpolated) = 1.34 W/kg

**Flat/Zoom Scan (5x5x7)/Cube 0:**

Measurement grid:  $dx=8\text{mm}$ ,  $dy=8\text{mm}$ ,  $dz=5\text{mm}$

Reference Value = 33.216 V/m; Power Drift = -0.07 dB

Peak SAR (extrapolated) = 1.54 W/kg

**SAR(1 g) = 1.11 W/kg; SAR(10 g) = 0.775 W/kg**

Maximum value of SAR (measured) = 1.34 W/kg

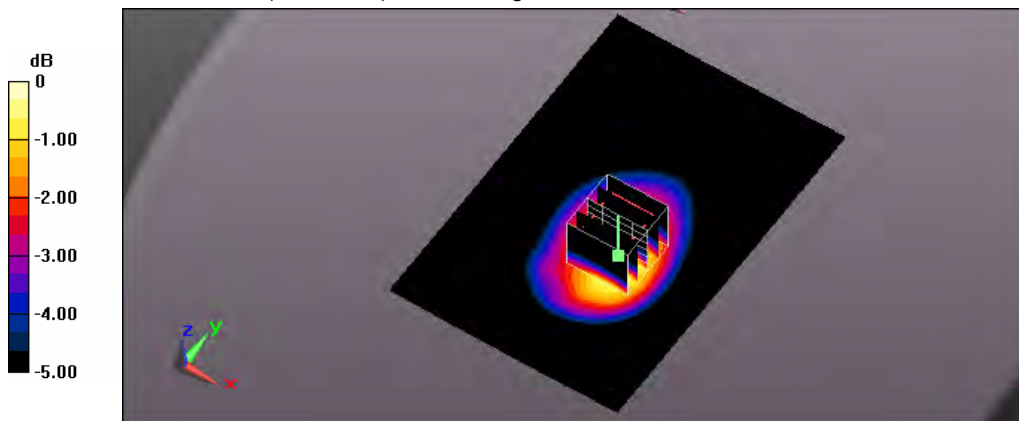

0 dB = 1.34 W/kg = 1.27 dBW/kg

Test Laboratory: A Test Lab Techno Corp.

Date: 2014/12/1 Time: PM 05:26:47

**79\_Flat\_LTE Band17 BW 10M CH23790\_QPSK with 1 RB Size 0 RB Offset side 2 surface to phantom 10mm**

**DUT: AC779S-200; Type: Mobile Hot Spot; Serial: 01426000002034**

Communication System: UID 0, Generic LTE (0); Frequency: 710 MHz; Duty Cycle: 1:1

Medium parameters used:  $f = 710 \text{ MHz}$ ;  $\sigma = 0.942 \text{ S/m}$ ;  $\epsilon_r = 53.665$ ;  $\rho = 1000 \text{ kg/m}^3$

Phantom section: Flat Section

Measurement Standard: DASY5 (IEEE/IEC/ANSI C63.19-2011)

DASY Configuration:

- Area Scan setting - Find Secondary Maximum Within: 2.0dB and with a peak SAR value greater than 0.5 W/Kg
- Probe: EX3DV4 - SN3977; ConvF(9.78, 9.78, 9.78); Calibrated: 2014/2/17;
- Sensor-Surface: 2mm (Mechanical Surface Detection)
- Electronics: DAE4 Sn779; Calibrated: 2014/2/25
- Phantom: ELI v5.0; Type: QDOVA002AA; Serial: TP:1133
- Measurement SW: DASY52, Version 52.8 (7); SEMCAD X Version 14.6.10 (7164)

**Flat/Area Scan (81x121x1):**

Interpolated grid:  $dx=1.500 \text{ mm}$ ,  $dy=1.500 \text{ mm}$

Maximum value of SAR (interpolated) = 1.31 W/kg

**Flat/Zoom Scan (5x5x7)/Cube 0:**

Measurement grid:  $dx=8\text{mm}$ ,  $dy=8\text{mm}$ ,  $dz=5\text{mm}$

Reference Value = 29.934 V/m; Power Drift = -0.06 dB

Peak SAR (extrapolated) = 1.54 W/kg

**SAR(1 g) = 1.07 W/kg; SAR(10 g) = 0.747 W/kg**

Maximum value of SAR (measured) = 1.32 W/kg

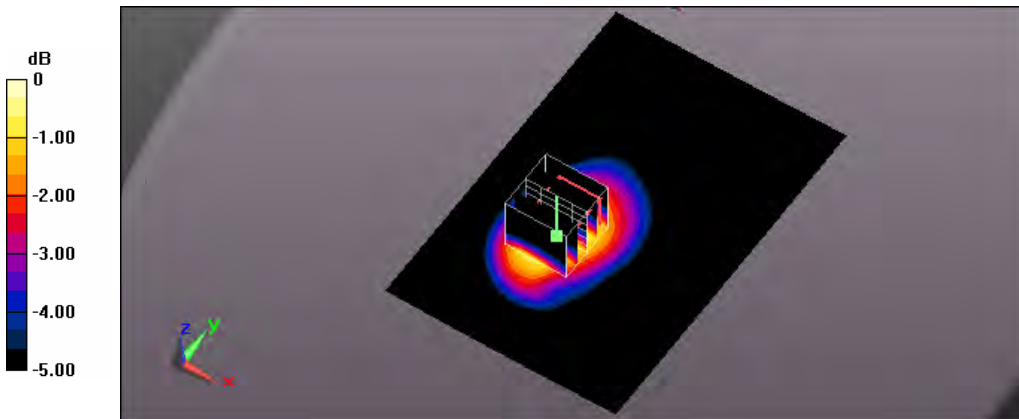

0 dB = 1.32 W/kg = 1.21 dBW/kg



Test Laboratory: A Test Lab Techno Corp.

Date: 2014/12/1 Time: PM 03:07:42

**73\_Flat\_LTE Band17 BW 10M CH23800\_QPSK with 1 RB Size 0 RB Offset side 1 surface to phantom 10mm**

**DUT: AC779S-200; Type: Mobile Hot Spot; Serial: 01426000002034**

Communication System: UID 0, Generic LTE (0); Frequency: 711 MHz; Duty Cycle: 1:1

Medium parameters used:  $f = 711 \text{ MHz}$ ;  $\sigma = 0.943 \text{ S/m}$ ;  $\epsilon_r = 53.644$ ;  $\rho = 1000 \text{ kg/m}^3$

Phantom section: Flat Section

Measurement Standard: DASYS (IEEE/IEC/ANSI C63.19-2011)

DASY Configuration:

- Area Scan setting - Find Secondary Maximum Within: 2.0dB and with a peak SAR value greater than 0.5 W/Kg
- Probe: EX3DV4 - SN3977; ConvF(9.78, 9.78, 9.78); Calibrated: 2014/2/17;
- Sensor-Surface: 2mm (Mechanical Surface Detection)
- Electronics: DAE4 Sn779; Calibrated: 2014/2/25
- Phantom: ELI v5.0; Type: QDOVA002AA; Serial: TP:1133
- Measurement SW: DASYS2, Version 52.8 (7); SEMCAD X Version 14.6.10 (7164)

**Flat/Area Scan (81x121x1):**

Interpolated grid:  $dx=1.500 \text{ mm}$ ,  $dy=1.500 \text{ mm}$

Maximum value of SAR (interpolated) = 1.32 W/kg

**Flat/Zoom Scan (5x5x7)/Cube 0:**

Measurement grid:  $dx=8\text{mm}$ ,  $dy=8\text{mm}$ ,  $dz=5\text{mm}$

Reference Value = 32.753 V/m; Power Drift = -0.05 dB

Peak SAR (extrapolated) = 1.50 W/kg

**SAR(1 g) = 1.07 W/kg; SAR(10 g) = 0.753 W/kg**

Maximum value of SAR (measured) = 1.29 W/kg

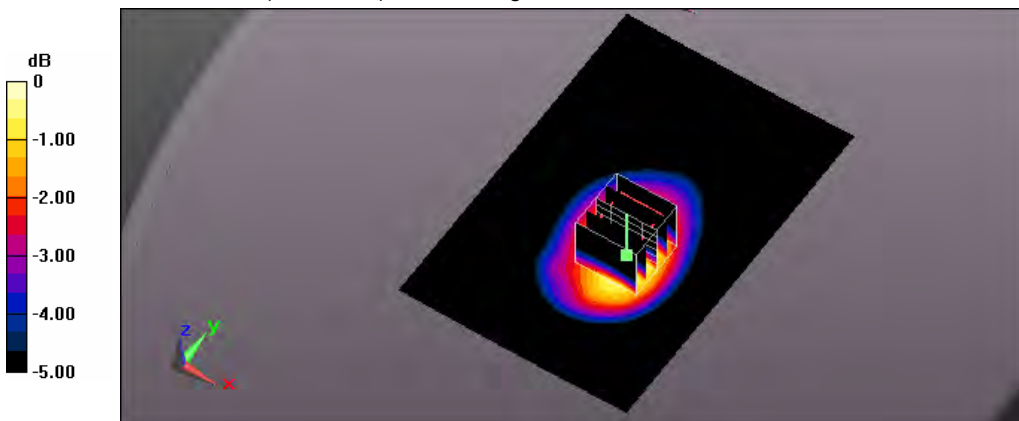

0 dB = 1.29 W/kg = 1.11 dBW/kg

Test Laboratory: A Test Lab Techno Corp.

Date: 2014/12/1 Time: PM 05:48:54

**80\_Flat\_LTE Band17 BW 10M CH23800\_QPSK with 1 RB Size 0 RB Offset side 2 surface to phantom 10mm**

**DUT: AC779S-200; Type: Mobile Hot Spot; Serial: 01426000002034**

Communication System: UID 0, Generic LTE (0); Frequency: 711 MHz; Duty Cycle: 1:1

Medium parameters used:  $f = 711 \text{ MHz}$ ;  $\sigma = 0.943 \text{ S/m}$ ;  $\epsilon_r = 53.644$ ;  $\rho = 1000 \text{ kg/m}^3$

Phantom section: Flat Section

Measurement Standard: DASY5 (IEEE/IEC/ANSI C63.19-2011)

DASY Configuration:

- Area Scan setting - Find Secondary Maximum Within: 2.0dB and with a peak SAR value greater than 0.5 W/Kg
- Probe: EX3DV4 - SN3977; ConvF(9.78, 9.78, 9.78); Calibrated: 2014/2/17;
- Sensor-Surface: 2mm (Mechanical Surface Detection)
- Electronics: DAE4 Sn779; Calibrated: 2014/2/25
- Phantom: ELI v5.0; Type: QDOVA002AA; Serial: TP:1133
- Measurement SW: DASY52, Version 52.8 (7); SEMCAD X Version 14.6.10 (7164)

**Flat/Area Scan (81x121x1):**

Interpolated grid:  $dx=1.500 \text{ mm}$ ,  $dy=1.500 \text{ mm}$

Maximum value of SAR (interpolated) = 1.29 W/kg

**Flat/Zoom Scan (5x5x7)/Cube 0:**

Measurement grid:  $dx=8\text{mm}$ ,  $dy=8\text{mm}$ ,  $dz=5\text{mm}$

Reference Value = 29.692 V/m; Power Drift = -0.01 dB

Peak SAR (extrapolated) = 1.49 W/kg

**SAR(1 g) = 1.03 W/kg; SAR(10 g) = 0.726 W/kg**

Maximum value of SAR (measured) = 1.27 W/kg

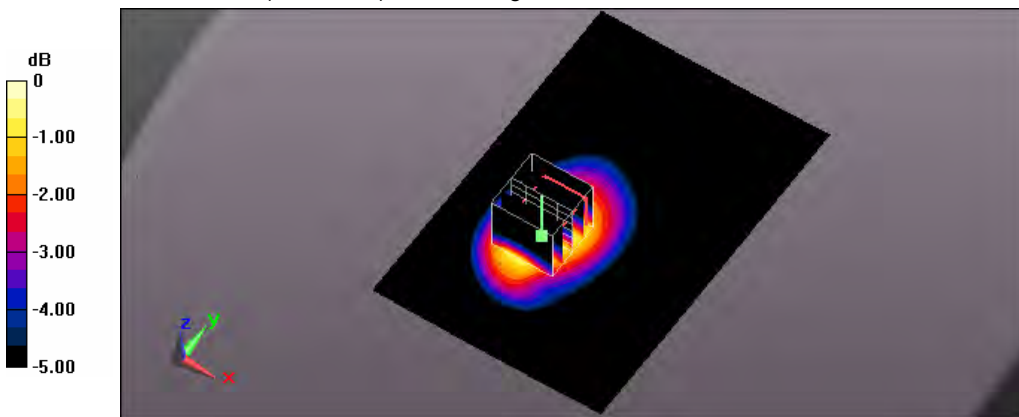

0 dB = 1.27 W/kg = 1.04 dBW/kg

Test Laboratory: A Test Lab Techno Corp.

Date: 2014/12/1 Time: PM 03:53:17

**75\_Flat\_LTE Band17 BW 10M CH23780\_QPSK with 25 RB Size 12 RB Offset side 1 surface to phantom 10mm**

**DUT: AC779S-200; Type: Mobile Hot Spot; Serial: 01426000002034**

Communication System: UID 0, Generic LTE (0); Frequency: 709 MHz; Duty Cycle: 1:1

Medium parameters used:  $f = 709 \text{ MHz}$ ;  $\sigma = 0.94 \text{ S/m}$ ;  $\epsilon_r = 53.708$ ;  $\rho = 1000 \text{ kg/m}^3$

Phantom section: Flat Section

Measurement Standard: DASY5 (IEEE/IEC/ANSI C63.19-2011)

DASY Configuration:

- Area Scan setting - Find Secondary Maximum Within: 2.0dB and with a peak SAR value greater than 0.5 W/Kg
- Probe: EX3DV4 - SN3977; ConvF(9.78, 9.78, 9.78); Calibrated: 2014/2/17;
- Sensor-Surface: 2mm (Mechanical Surface Detection)
- Electronics: DAE4 Sn779; Calibrated: 2014/2/25
- Phantom: ELI v5.0; Type: QDOVA002AA; Serial: TP:1133
- Measurement SW: DASY52, Version 52.8 (7); SEMCAD X Version 14.6.10 (7164)

**Flat/Area Scan (81x121x1):**

Interpolated grid:  $dx=1.500 \text{ mm}$ ,  $dy=1.500 \text{ mm}$

Maximum value of SAR (interpolated) = 1.03 W/kg

**Flat/Zoom Scan (5x5x7)/Cube 0:**

Measurement grid:  $dx=8\text{mm}$ ,  $dy=8\text{mm}$ ,  $dz=5\text{mm}$

Reference Value = 29.073 V/m; Power Drift = -0.05 dB

Peak SAR (extrapolated) = 1.22 W/kg

**SAR(1 g) = 0.853 W/kg; SAR(10 g) = 0.598 W/kg**

Maximum value of SAR (measured) = 1.04 W/kg

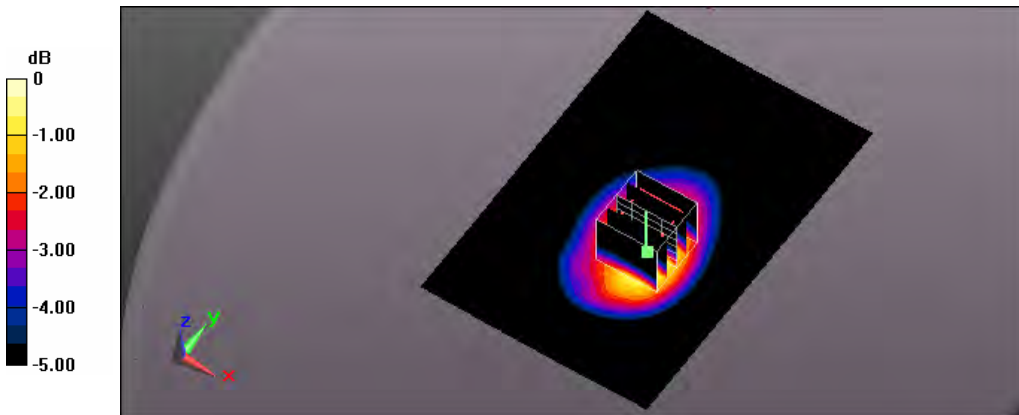

0 dB = 1.04 W/kg = 0.17 dBW/kg

Test Laboratory: A Test Lab Techno Corp.

Date: 2014/12/1 Time: PM 06:36:33

**82\_Flat\_LTE Band17 BW 10M CH23780\_QPSK with 25 RB Size 12 RB Offset side 2 surface to phantom 10mm**

**DUT: AC779S-200; Type: Mobile Hot Spot; Serial: 01426000002034**

Communication System: UID 0, Generic LTE (0); Frequency: 709 MHz; Duty Cycle: 1:1

Medium parameters used:  $f = 709 \text{ MHz}$ ;  $\sigma = 0.94 \text{ S/m}$ ;  $\epsilon_r = 53.708$ ;  $\rho = 1000 \text{ kg/m}^3$

Phantom section: Flat Section

Measurement Standard: DASY5 (IEEE/IEC/ANSI C63.19-2011)

DASY Configuration:

- Area Scan setting - Find Secondary Maximum Within: 2.0dB and with a peak SAR value greater than 0.5 W/Kg
- Probe: EX3DV4 - SN3977; ConvF(9.78, 9.78, 9.78); Calibrated: 2014/2/17;
- Sensor-Surface: 2mm (Mechanical Surface Detection)
- Electronics: DAE4 Sn779; Calibrated: 2014/2/25
- Phantom: ELI v5.0; Type: QDOVA002AA; Serial: TP:1133
- Measurement SW: DASY52, Version 52.8 (7); SEMCAD X Version 14.6.10 (7164)

**Flat/Area Scan (81x121x1):**

Interpolated grid:  $dx=1.500 \text{ mm}$ ,  $dy=1.500 \text{ mm}$

Maximum value of SAR (interpolated) = 0.984 W/kg

**Flat/Zoom Scan (5x5x7)/Cube 0:**

Measurement grid:  $dx=8\text{mm}$ ,  $dy=8\text{mm}$ ,  $dz=5\text{mm}$

Reference Value = 26.426 V/m; Power Drift = 0.02 dB

Peak SAR (extrapolated) = 1.14 W/kg

**SAR(1 g) = 0.809 W/kg; SAR(10 g) = 0.566 W/kg**

Maximum value of SAR (measured) = 0.996 W/kg

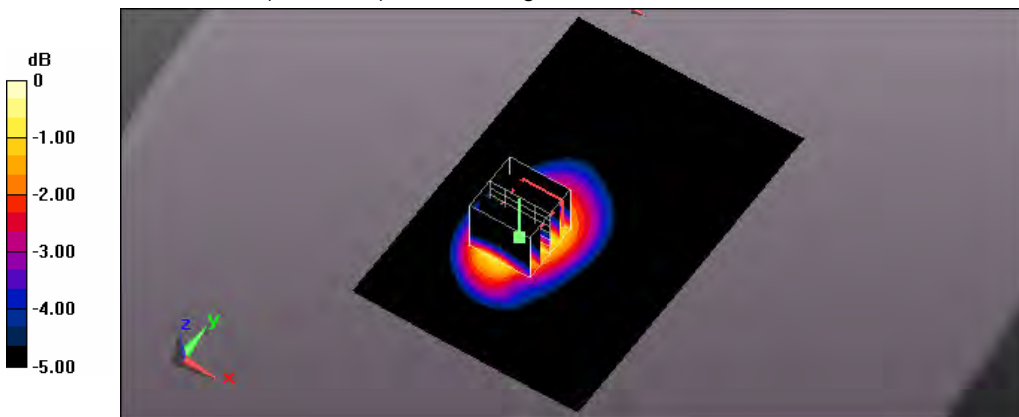

0 dB = 0.996 W/kg = -0.02 dBW/kg

Test Laboratory: A Test Lab Techno Corp.

Date: 2014/12/1 Time: PM 03:30:53

**74\_Flat\_LTE Band17 BW 10M CH23790\_QPSK with 25 RB Size 12 RB Offset side 1 surface to phantom 10mm**

**DUT: AC779S-200; Type: Mobile Hot Spot; Serial: 014260000002034**

Communication System: UID 0, Generic LTE (0); Frequency: 710 MHz; Duty Cycle: 1:1

Medium parameters used:  $f = 710 \text{ MHz}$ ;  $\sigma = 0.942 \text{ S/m}$ ;  $\epsilon_r = 53.665$ ;  $\rho = 1000 \text{ kg/m}^3$

Phantom section: Flat Section

Measurement Standard: DASY5 (IEEE/IEC/ANSI C63.19-2011)

DASY Configuration:

- Area Scan setting - Find Secondary Maximum Within: 2.0dB and with a peak SAR value greater than 0.5 W/Kg
- Probe: EX3DV4 - SN3977; ConvF(9.78, 9.78, 9.78); Calibrated: 2014/2/17;
- Sensor-Surface: 2mm (Mechanical Surface Detection)
- Electronics: DAE4 Sn779; Calibrated: 2014/2/25
- Phantom: ELI v5.0; Type: QDOVA002AA; Serial: TP:1133
- Measurement SW: DASY52, Version 52.8 (7); SEMCAD X Version 14.6.10 (7164)

**Flat/Area Scan (81x121x1):**

Interpolated grid:  $dx=1.500 \text{ mm}$ ,  $dy=1.500 \text{ mm}$

Maximum value of SAR (interpolated) = 1.03 W/kg

**Flat/Zoom Scan (5x5x7)/Cube 0:**

Measurement grid:  $dx=8\text{mm}$ ,  $dy=8\text{mm}$ ,  $dz=5\text{mm}$

Reference Value = 29.107 V/m; Power Drift = -0.09 dB

Peak SAR (extrapolated) = 1.22 W/kg

**SAR(1 g) = 0.851 W/kg; SAR(10 g) = 0.599 W/kg**

Maximum value of SAR (measured) = 1.04 W/kg

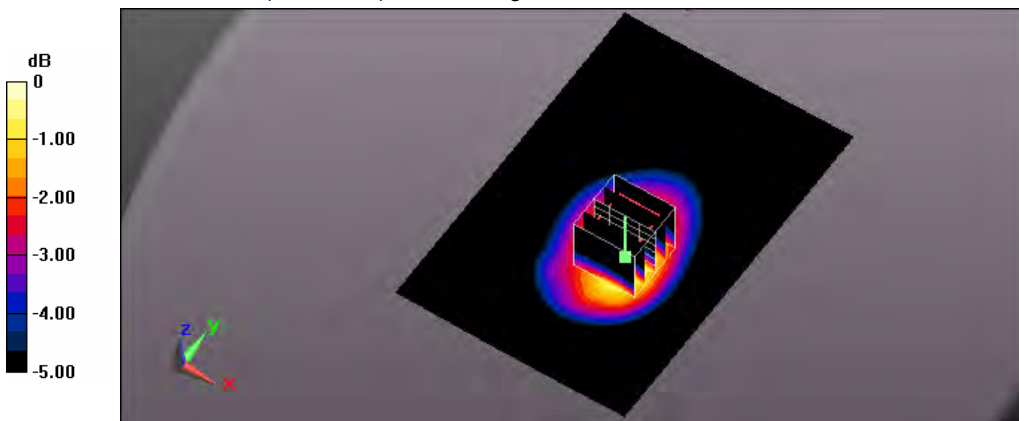

0 dB = 1.04 W/kg = 0.17 dBW/kg

Test Laboratory: A Test Lab Techno Corp.

Date: 2014/12/1 Time: PM 06:13:12

**81\_Flat\_LTE Band17 BW 10M CH23790\_QPSK with 25 RB Size 12 RB Offset side 2 surface to phantom 10mm**

**DUT: AC779S-200; Type: Mobile Hot Spot; Serial: 01426000002034**

Communication System: UID 0, Generic LTE (0); Frequency: 710 MHz; Duty Cycle: 1:1

Medium parameters used:  $f = 710 \text{ MHz}$ ;  $\sigma = 0.942 \text{ S/m}$ ;  $\epsilon_r = 53.665$ ;  $\rho = 1000 \text{ kg/m}^3$

Phantom section: Flat Section

Measurement Standard: DASYS (IEEE/IEC/ANSI C63.19-2011)

DASY Configuration:

- Area Scan setting - Find Secondary Maximum Within: 2.0dB and with a peak SAR value greater than 0.5 W/Kg
- Probe: EX3DV4 - SN3977; ConvF(9.78, 9.78, 9.78); Calibrated: 2014/2/17;
- Sensor-Surface: 2mm (Mechanical Surface Detection)
- Electronics: DAE4 Sn779; Calibrated: 2014/2/25
- Phantom: ELI v5.0; Type: QDOVA002AA; Serial: TP:1133
- Measurement SW: DASYS2, Version 52.8 (7); SEMCAD X Version 14.6.10 (7164)

**Flat/Area Scan (81x121x1):**

Interpolated grid:  $dx=1.500 \text{ mm}$ ,  $dy=1.500 \text{ mm}$

Maximum value of SAR (interpolated) = 0.994 W/kg

**Flat/Zoom Scan (5x5x7)/Cube 0:**

Measurement grid:  $dx=8\text{mm}$ ,  $dy=8\text{mm}$ ,  $dz=5\text{mm}$

Reference Value = 26.452 V/m; Power Drift = 0.05 dB

Peak SAR (extrapolated) = 1.15 W/kg

**SAR(1 g) = 0.819 W/kg; SAR(10 g) = 0.573 W/kg**

Maximum value of SAR (measured) = 1.01 W/kg

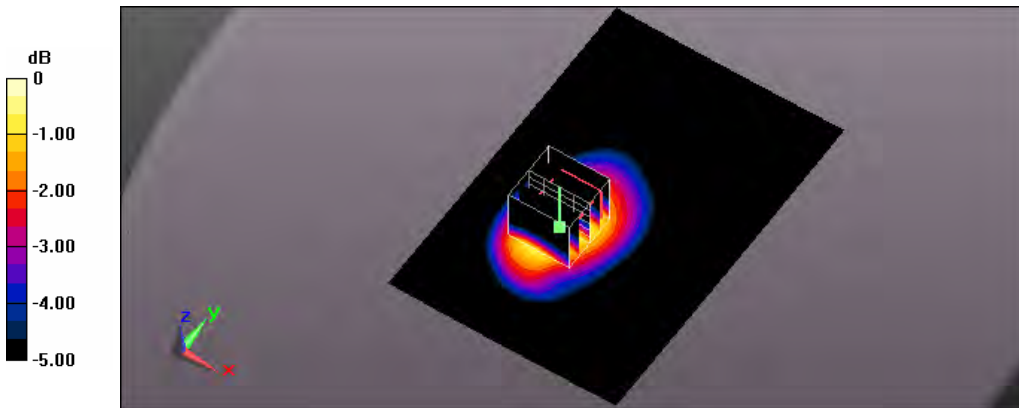

0 dB = 1.01 W/kg = 0.04 dBW/kg

Test Laboratory: A Test Lab Techno Corp.

Date: 2014/12/1 Time: PM 07:53:22

**85\_Flat\_LTE Band17 BW 10M CH23790\_QPSK with 25 RB Size 12 RB Offset side 3 surface to phantom 10mm**

**DUT: AC779S-200; Type: Mobile Hot Spot; Serial: 014260000002034**

Communication System: UID 0, Generic LTE (0); Frequency: 710 MHz; Duty Cycle: 1:1

Medium parameters used:  $f = 710 \text{ MHz}$ ;  $\sigma = 0.942 \text{ S/m}$ ;  $\epsilon_r = 53.665$ ;  $\rho = 1000 \text{ kg/m}^3$

Phantom section: Flat Section

Measurement Standard: DASY5 (IEEE/IEC/ANSI C63.19-2011)

DASY Configuration:

- Area Scan setting - Find Secondary Maximum Within: 2.0dB and with a peak SAR value greater than 0.5 W/Kg
- Probe: EX3DV4 - SN3977; ConvF(9.78, 9.78, 9.78); Calibrated: 2014/2/17;
- Sensor-Surface: 2mm (Mechanical Surface Detection)
- Electronics: DAE4 Sn779; Calibrated: 2014/2/25
- Phantom: ELI v5.0; Type: QDOVA002AA; Serial: TP:1133
- Measurement SW: DASY52, Version 52.8 (7); SEMCAD X Version 14.6.10 (7164)

**Flat/Area Scan (61x111x1):**

Interpolated grid:  $dx=1.500 \text{ mm}$ ,  $dy=1.500 \text{ mm}$

Maximum value of SAR (interpolated) = 0.348 W/kg

**Flat/Zoom Scan (5x5x7)/Cube 0:**

Measurement grid:  $dx=8\text{mm}$ ,  $dy=8\text{mm}$ ,  $dz=5\text{mm}$

Reference Value = 18.568 V/m; Power Drift = 0.03 dB

Peak SAR (extrapolated) = 0.387 W/kg

**SAR(1 g) = 0.288 W/kg; SAR(10 g) = 0.207 W/kg**

Maximum value of SAR (measured) = 0.345 W/kg

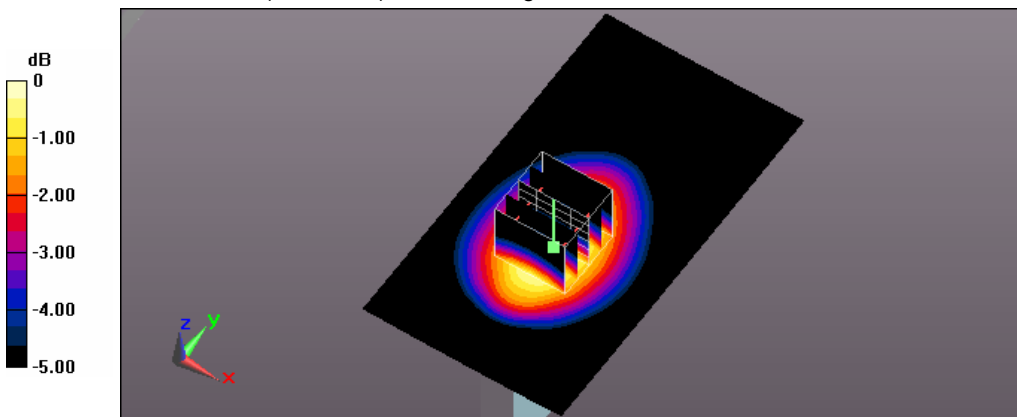

0 dB = 0.345 W/kg = -4.62 dBW/kg

Test Laboratory: A Test Lab Techno Corp.

Date: 2014/12/1 Time: PM 08:49:09

**88\_Flat\_LTE Band17 BW 10M CH23790\_QPSK with 25 RB Size 12 RB Offset side 4 surface to phantom 10mm**

**DUT: AC779S-200; Type: Mobile Hot Spot; Serial: 014260000002034**

Communication System: UID 0, Generic LTE (0); Frequency: 710 MHz; Duty Cycle: 1:1

Medium parameters used:  $f = 710 \text{ MHz}$ ;  $\sigma = 0.942 \text{ S/m}$ ;  $\epsilon_r = 53.665$ ;  $\rho = 1000 \text{ kg/m}^3$

Phantom section: Flat Section

Measurement Standard: DASYS (IEEE/IEC/ANSI C63.19-2011)

DASY Configuration:

- Area Scan setting - Find Secondary Maximum Within: 2.0dB and with a peak SAR value greater than 0.5 W/Kg
- Probe: EX3DV4 - SN3977; ConvF(9.78, 9.78, 9.78); Calibrated: 2014/2/17;
- Sensor-Surface: 2mm (Mechanical Surface Detection)
- Electronics: DAE4 Sn779; Calibrated: 2014/2/25
- Phantom: ELI v5.0; Type: QDOVA002AA; Serial: TP:1133
- Measurement SW: DASYS2, Version 52.8 (7); SEMCAD X Version 14.6.10 (7164)

**Flat/Area Scan (61x111x1):**

Interpolated grid:  $dx=1.500 \text{ mm}$ ,  $dy=1.500 \text{ mm}$

Maximum value of SAR (interpolated) = 0.566 W/kg

**Flat/Zoom Scan (5x5x7)/Cube 0:**

Measurement grid:  $dx=8\text{mm}$ ,  $dy=8\text{mm}$ ,  $dz=5\text{mm}$

Reference Value = 23.382 V/m; Power Drift = 0.00 dB

Peak SAR (extrapolated) = 0.639 W/kg

**SAR(1 g) = 0.452 W/kg; SAR(10 g) = 0.309 W/kg**

Maximum value of SAR (measured) = 0.557 W/kg

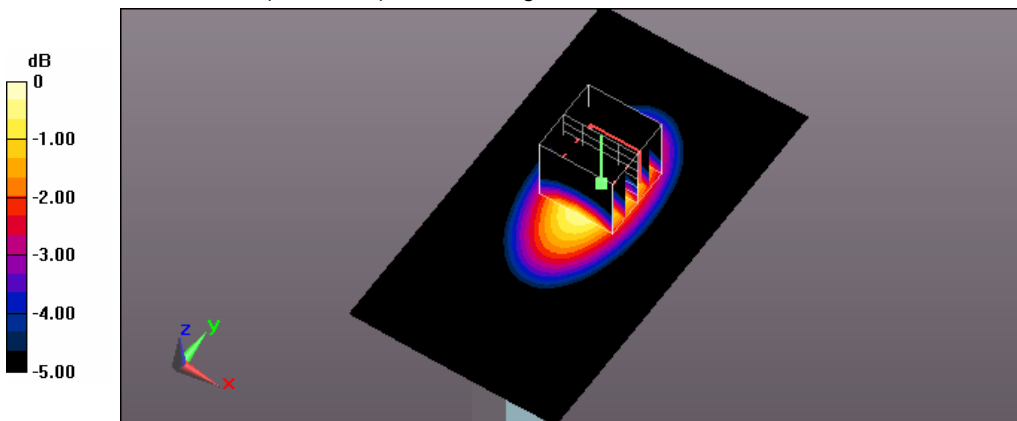

0 dB = 0.557 W/kg = -2.54 dBW/kg



Test Laboratory: A Test Lab Techno Corp.

Date: 2014/12/1 Time: PM 09:27:28

**89\_Flat\_LTE Band17 BW 10M CH23790\_QPSK with 25 RB Size 12 RB Offset side 5 surface to phantom 10mm**

**DUT: AC779S-200; Type: Mobile Hot Spot; Serial: 01426000002034**

Communication System: UID 0, Generic LTE (0); Frequency: 710 MHz; Duty Cycle: 1:1

Medium parameters used:  $f = 710 \text{ MHz}$ ;  $\sigma = 0.942 \text{ S/m}$ ;  $\epsilon_r = 53.665$ ;  $\rho = 1000 \text{ kg/m}^3$

Phantom section: Flat Section

Measurement Standard: DASY5 (IEEE/IEC/ANSI C63.19-2011)

DASY Configuration:

- Area Scan setting - Find Secondary Maximum Within: 2.0dB and with a peak SAR value greater than 0.5 W/Kg
- Probe: EX3DV4 - SN3977; ConvF(9.78, 9.78, 9.78); Calibrated: 2014/2/17;
- Sensor-Surface: 2mm (Mechanical Surface Detection)
- Electronics: DAE4 Sn779; Calibrated: 2014/2/25
- Phantom: ELI v5.0; Type: QDOVA002AA; Serial: TP:1133
- Measurement SW: DASY52, Version 52.8 (7); SEMCAD X Version 14.6.10 (7164)

**Flat/Area Scan (61x101x1):**

Interpolated grid:  $dx=1.500 \text{ mm}$ ,  $dy=1.500 \text{ mm}$

Maximum value of SAR (interpolated) = 0.136 W/kg

**Flat/Zoom Scan (5x5x7)/Cube 0:**

Measurement grid:  $dx=8\text{mm}$ ,  $dy=8\text{mm}$ ,  $dz=5\text{mm}$

Reference Value = 12.278 V/m; Power Drift = 0.06 dB

Peak SAR (extrapolated) = 0.176 W/kg

**SAR(1 g) = 0.102 W/kg; SAR(10 g) = 0.061 W/kg**

Maximum value of SAR (measured) = 0.141 W/kg

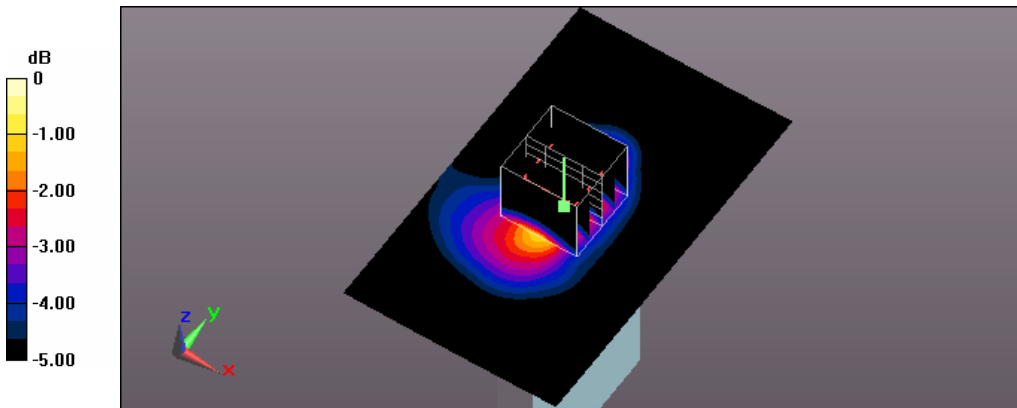

0 dB = 0.141 W/kg = -8.51 dBW/kg

Test Laboratory: A Test Lab Techno Corp.

Date: 2014/12/1 Time: PM 04:16:29

**76\_Flat\_LTE Band17 BW 10M CH23800\_QPSK with 25 RB Size 12 RB Offset side 1 surface to phantom 10mm**

**DUT: AC779S-200; Type: Mobile Hot Spot; Serial: 01426000002034**

Communication System: UID 0, Generic LTE (0); Frequency: 711 MHz; Duty Cycle: 1:1

Medium parameters used:  $f = 711 \text{ MHz}$ ;  $\sigma = 0.943 \text{ S/m}$ ;  $\epsilon_r = 53.644$ ;  $\rho = 1000 \text{ kg/m}^3$

Phantom section: Flat Section

Measurement Standard: DASY5 (IEEE/IEC/ANSI C63.19-2011)

DASY Configuration:

- Area Scan setting - Find Secondary Maximum Within: 2.0dB and with a peak SAR value greater than 0.5 W/Kg
- Probe: EX3DV4 - SN3977; ConvF(9.78, 9.78, 9.78); Calibrated: 2014/2/17;
- Sensor-Surface: 2mm (Mechanical Surface Detection)
- Electronics: DAE4 Sn779; Calibrated: 2014/2/25
- Phantom: ELI v5.0; Type: QDOVA002AA; Serial: TP:1133
- Measurement SW: DASY52, Version 52.8 (7); SEMCAD X Version 14.6.10 (7164)

**Flat/Area Scan (81x121x1):**

Interpolated grid:  $dx=1.500 \text{ mm}$ ,  $dy=1.500 \text{ mm}$

Maximum value of SAR (interpolated) = 1.04 W/kg

**Flat/Zoom Scan (5x5x7)/Cube 0:**

Measurement grid:  $dx=8\text{mm}$ ,  $dy=8\text{mm}$ ,  $dz=5\text{mm}$

Reference Value = 28.937 V/m; Power Drift = 0.02 dB

Peak SAR (extrapolated) = 1.22 W/kg

**SAR(1 g) = 0.853 W/kg; SAR(10 g) = 0.600 W/kg**

Maximum value of SAR (measured) = 1.04 W/kg

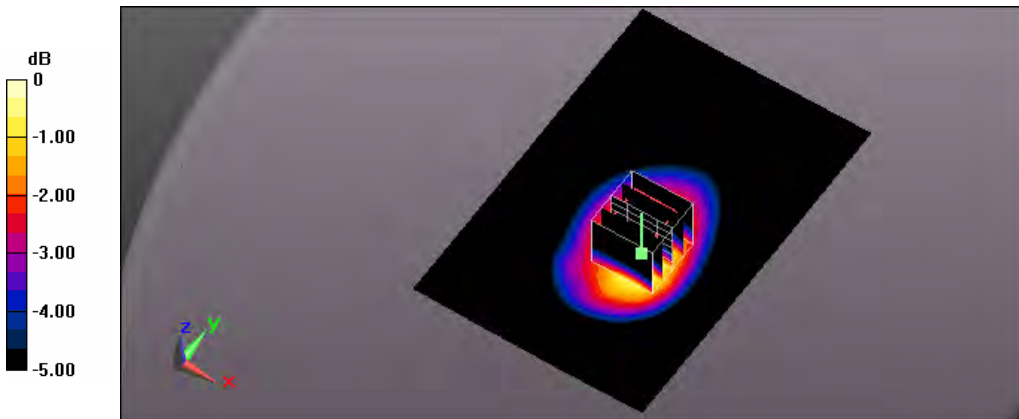

0 dB = 1.04 W/kg = 0.17 dBW/kg

Test Laboratory: A Test Lab Techno Corp.

Date: 2014/12/1 Time: PM 07:03:52

**83\_Flat\_LTE Band17 BW 10M CH23800\_QPSK with 25 RB Size 12 RB Offset side 2 surface to phantom 10mm**

**DUT: AC779S-200; Type: Mobile Hot Spot; Serial: 01426000002034**

Communication System: UID 0, Generic LTE (0); Frequency: 711 MHz; Duty Cycle: 1:1

Medium parameters used:  $f = 711 \text{ MHz}$ ;  $\sigma = 0.943 \text{ S/m}$ ;  $\epsilon_r = 53.644$ ;  $\rho = 1000 \text{ kg/m}^3$

Phantom section: Flat Section

Measurement Standard: DASY5 (IEEE/IEC/ANSI C63.19-2011)

DASY Configuration:

- Area Scan setting - Find Secondary Maximum Within: 2.0dB and with a peak SAR value greater than 0.5 W/Kg
- Probe: EX3DV4 - SN3977; ConvF(9.78, 9.78, 9.78); Calibrated: 2014/2/17;
- Sensor-Surface: 2mm (Mechanical Surface Detection)
- Electronics: DAE4 Sn779; Calibrated: 2014/2/25
- Phantom: ELI v5.0; Type: QDOVA002AA; Serial: TP:1133
- Measurement SW: DASY52, Version 52.8 (7); SEMCAD X Version 14.6.10 (7164)

**Flat/Area Scan (81x121x1):**

Interpolated grid:  $dx=1.500 \text{ mm}$ ,  $dy=1.500 \text{ mm}$

Maximum value of SAR (interpolated) = 0.986 W/kg

**Flat/Zoom Scan (5x5x7)/Cube 0:**

Measurement grid:  $dx=8\text{mm}$ ,  $dy=8\text{mm}$ ,  $dz=5\text{mm}$

Reference Value = 26.723 V/m; Power Drift = 0.02 dB

Peak SAR (extrapolated) = 1.17 W/kg

**SAR(1 g) = 0.823 W/kg; SAR(10 g) = 0.575 W/kg**

Maximum value of SAR (measured) = 1.01 W/kg

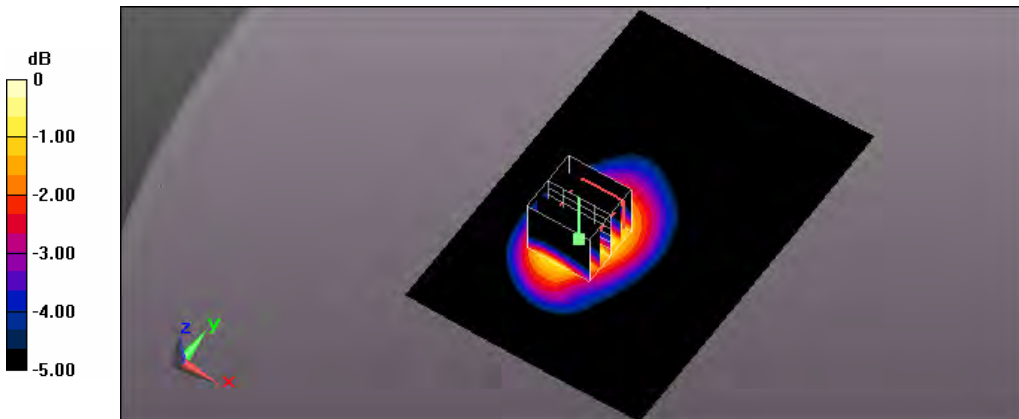

0 dB = 1.01 W/kg = 0.04 dBW/kg

Test Laboratory: A Test Lab Techno Corp.

Date: 2014/12/1 Time: PM 04:38:25

**77\_Flat\_LTE Band17 BW 10M CH23790\_QPSK with 50 RB Size 0 RB Offset side 1 surface to phantom 10mm**

**DUT: AC779S-200; Type: Mobile Hot Spot; Serial: 01426000002034**

Communication System: UID 0, Generic LTE (0); Frequency: 710 MHz; Duty Cycle: 1:1

Medium parameters used:  $f = 710 \text{ MHz}$ ;  $\sigma = 0.942 \text{ S/m}$ ;  $\epsilon_r = 53.665$ ;  $\rho = 1000 \text{ kg/m}^3$

Phantom section: Flat Section

Measurement Standard: DASY5 (IEEE/IEC/ANSI C63.19-2011)

DASY Configuration:

- Area Scan setting - Find Secondary Maximum Within: 2.0dB and with a peak SAR value greater than 0.5 W/Kg
- Probe: EX3DV4 - SN3977; ConvF(9.78, 9.78, 9.78); Calibrated: 2014/2/17;
- Sensor-Surface: 2mm (Mechanical Surface Detection)
- Electronics: DAE4 Sn779; Calibrated: 2014/2/25
- Phantom: ELI v5.0; Type: QDOVA002AA; Serial: TP:1133
- Measurement SW: DASY52, Version 52.8 (7); SEMCAD X Version 14.6.10 (7164)

**Flat/Area Scan (81x121x1):**

Interpolated grid:  $dx=1.500 \text{ mm}$ ,  $dy=1.500 \text{ mm}$

Maximum value of SAR (interpolated) = 0.994 W/kg

**Flat/Zoom Scan (5x5x7)/Cube 0:**

Measurement grid:  $dx=8\text{mm}$ ,  $dy=8\text{mm}$ ,  $dz=5\text{mm}$

Reference Value = 28.733 V/m; Power Drift = -0.13 dB

Peak SAR (extrapolated) = 1.16 W/kg

**SAR(1 g) = 0.818 W/kg; SAR(10 g) = 0.576 W/kg**

Maximum value of SAR (measured) = 0.994 W/kg

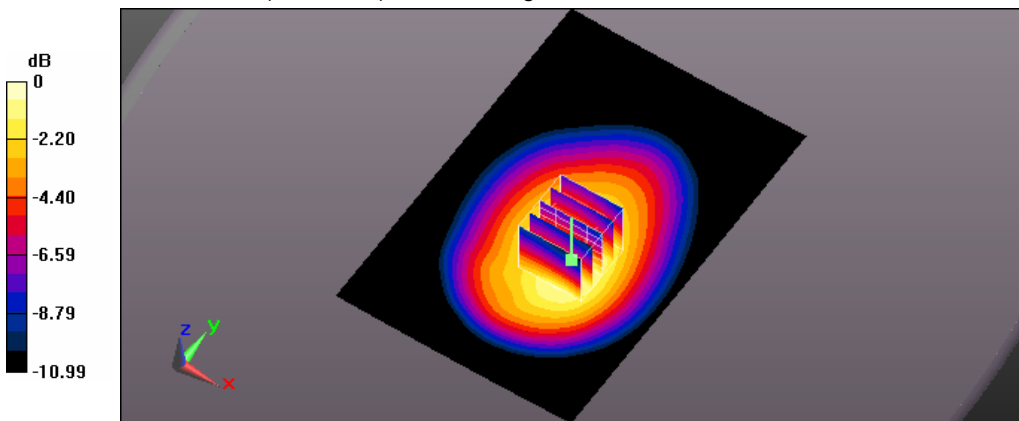

0 dB = 0.994 W/kg = -0.03 dBW/kg

Test Laboratory: A Test Lab Techno Corp.

Date: 2014/12/1 Time: PM 07:27:51

**84\_Flat\_LTE Band17 BW 10M CH23790\_QPSK with 50 RB Size 0 RB Offset side 2 surface to phantom 10mm**

**DUT: AC779S-200; Type: Mobile Hot Spot; Serial: 01426000002034**

Communication System: UID 0, Generic LTE (0); Frequency: 710 MHz; Duty Cycle: 1:1

Medium parameters used:  $f = 710 \text{ MHz}$ ;  $\sigma = 0.942 \text{ S/m}$ ;  $\epsilon_r = 53.665$ ;  $\rho = 1000 \text{ kg/m}^3$

Phantom section: Flat Section

Measurement Standard: DASYS (IEEE/IEC/ANSI C63.19-2011)

DASY Configuration:

- Area Scan setting - Find Secondary Maximum Within: 2.0dB and with a peak SAR value greater than 0.5 W/Kg
- Probe: EX3DV4 - SN3977; ConvF(9.78, 9.78, 9.78); Calibrated: 2014/2/17;
- Sensor-Surface: 2mm (Mechanical Surface Detection)
- Electronics: DAE4 Sn779; Calibrated: 2014/2/25
- Phantom: ELI v5.0; Type: QDOVA002AA; Serial: TP:1133
- Measurement SW: DASYS2, Version 52.8 (7); SEMCAD X Version 14.6.10 (7164)

**Flat/Area Scan (81x121x1):**

Interpolated grid:  $dx=1.500 \text{ mm}$ ,  $dy=1.500 \text{ mm}$

Maximum value of SAR (interpolated) = 0.958 W/kg

**Flat/Zoom Scan (5x5x7)/Cube 0:**

Measurement grid:  $dx=8\text{mm}$ ,  $dy=8\text{mm}$ ,  $dz=5\text{mm}$

Reference Value = 26.324 V/m; Power Drift = -0.07 dB

Peak SAR (extrapolated) = 1.13 W/kg

**SAR(1 g) = 0.790 W/kg; SAR(10 g) = 0.552 W/kg**

Maximum value of SAR (measured) = 0.973 W/kg

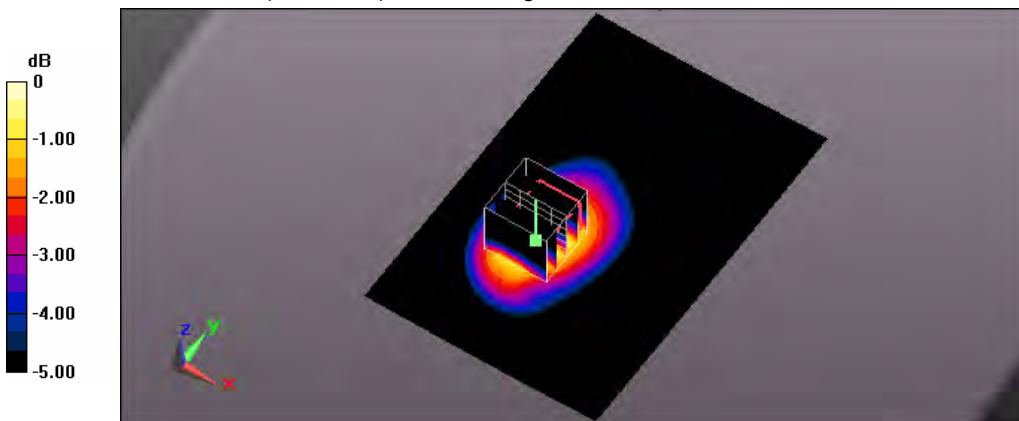

0 dB = 0.973 W/kg = -0.12 dBW/kg

Test Laboratory: A Test Lab Techno Corp.

Date: 2014/12/17 Time: AM 12:05:12

**22 Flat LTE Band2 BW 20M CH18700\_QPSK with 1 RB Size 99 RB Offset \_original #1\_side 1 surface to phantom 10mm\_measurement once**

**DUT: AC779S-200; Type: Mobile Hot Spot; Serial: 01426000002034**

Communication System: UID 0, Generic LTE (0); Frequency: 1860 MHz; Duty Cycle: 1:1

Medium parameters used:  $f = 1860 \text{ MHz}$ ;  $\sigma = 1.472 \text{ S/m}$ ;  $\epsilon_r = 51.827$ ;  $\rho = 1000 \text{ kg/m}^3$

Phantom section: Flat Section

Measurement Standard: DASYS (IEEE/IEC/ANSI C63.19-2011)

DASY Configuration:

- Area Scan setting - Find Secondary Maximum Within: 2.0dB and with a peak SAR value greater than 0.5 W/Kg
- Probe: EX3DV4 - SN3977; ConvF(7.37, 7.37, 7.37); Calibrated: 2014/2/17;
- Sensor-Surface: 2mm (Mechanical Surface Detection)
- Electronics: DAE4 Sn779; Calibrated: 2014/2/25
- Phantom: ELI v5.0; Type: QDOVA002AA; Serial: TP:1133
- Measurement SW: DASYS2, Version 52.8 (7); SEMCAD X Version 14.6.10 (7164)

**Flat/Area Scan (81x121x1):**

Interpolated grid:  $dx=1.500 \text{ mm}$ ,  $dy=1.500 \text{ mm}$

Maximum value of SAR (interpolated) = 1.71 W/kg

**Flat/Zoom Scan (5x5x7)/Cube 0:**

Measurement grid:  $dx=8\text{mm}$ ,  $dy=8\text{mm}$ ,  $dz=5\text{mm}$

Reference Value = 11.437 V/m; Power Drift = 0.17 dB

Peak SAR (extrapolated) = 1.99 W/kg

**SAR(1 g) = 1.16 W/kg; SAR(10 g) = 0.646 W/kg**

Maximum value of SAR (measured) = 1.57 W/kg

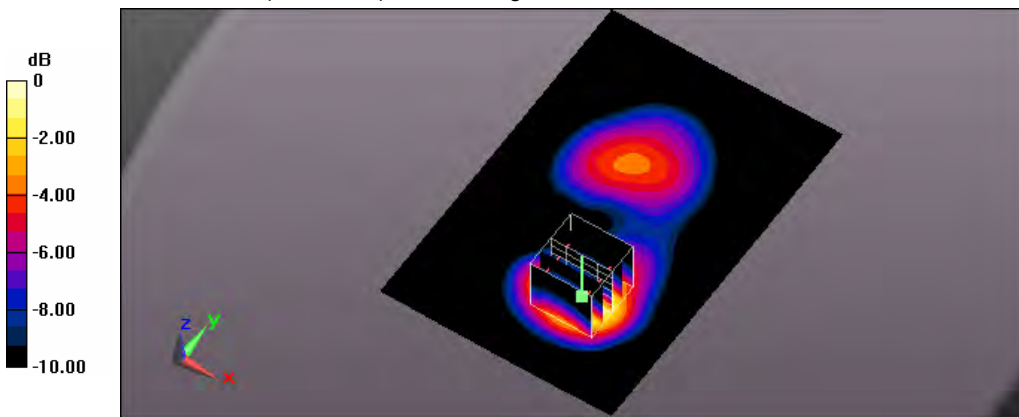

0 dB = 1.57 W/kg = 1.96 dBW/kg

Test Laboratory: A Test Lab Techno Corp.

Date: 2014/12/17 Time: AM 12:53:07

**23\_Flat\_LTE Band2 BW 20M CH18700\_QPSK with 1 RB Size 99 RB Offset \_original #1\_side 1 surface to phantom 10mm\_measurement second**

**DUT: AC779S-200; Type: Mobile Hot Spot; Serial: 01426000002034**

Communication System: UID 0, Generic LTE (0); Frequency: 1860 MHz; Duty Cycle: 1:1

Medium parameters used:  $f = 1860 \text{ MHz}$ ;  $\sigma = 1.472 \text{ S/m}$ ;  $\epsilon_r = 51.827$ ;  $\rho = 1000 \text{ kg/m}^3$

Phantom section: Flat Section

Measurement Standard: DASYS (IEEE/IEC/ANSI C63.19-2011)

DASY Configuration:

- Area Scan setting - Find Secondary Maximum Within: 2.0dB and with a peak SAR value greater than 0.5 W/Kg
- Probe: EX3DV4 - SN3977; ConvF(7.37, 7.37, 7.37); Calibrated: 2014/2/17;
- Sensor-Surface: 2mm (Mechanical Surface Detection)
- Electronics: DAE4 Sn779; Calibrated: 2014/2/25
- Phantom: ELI v5.0; Type: QDOVA002AA; Serial: TP:1133
- Measurement SW: DASYS2, Version 52.8 (7); SEMCAD X Version 14.6.10 (7164)

**Flat/Area Scan (81x121x1):**

Interpolated grid:  $dx=1.500 \text{ mm}$ ,  $dy=1.500 \text{ mm}$

Maximum value of SAR (interpolated) = 1.62 W/kg

**Flat/Zoom Scan (5x5x7)/Cube 0:**

Measurement grid:  $dx=8\text{mm}$ ,  $dy=8\text{mm}$ ,  $dz=5\text{mm}$

Reference Value = 11.721 V/m; Power Drift = -0.06 dB

Peak SAR (extrapolated) = 2.05 W/kg

**SAR(1 g) = 1.19 W/kg; SAR(10 g) = 0.657 W/kg**

Maximum value of SAR (measured) = 1.62 W/kg

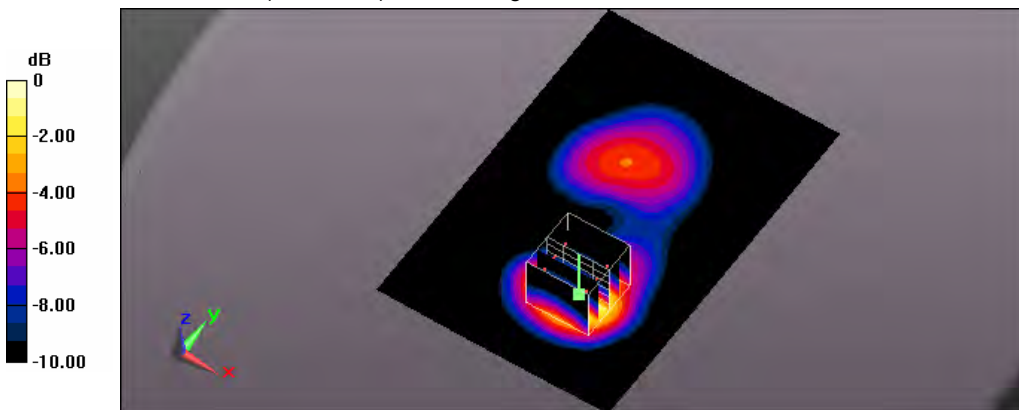

0 dB = 1.62 W/kg = 2.10 dBW/kg



Test Laboratory: A Test Lab Techno Corp.

Date: 2014/12/17 Time: AM 01:16:05

**100\_Flat\_LTE Band2 BW 20M CH18700\_QPSK with 1 RB Size 99 RB Offset \_original #1\_side 1 surface to phantom 10mm\_measurement third**

**DUT: AC779S-200; Type: Mobile Hot Spot; Serial: 01426000002034**

Communication System: UID 0, Generic LTE (0); Frequency: 1860 MHz; Duty Cycle: 1:1

Medium parameters used:  $f = 1860$  MHz;  $\sigma = 1.472$  S/m;  $\epsilon_r = 51.827$ ;  $\rho = 1000$  kg/m<sup>3</sup>

Phantom section: Flat Section

Measurement Standard: DASYS (IEEE/IEC/ANSI C63.19-2011)

DASY Configuration:

- Area Scan setting - Find Secondary Maximum Within: 2.0dB and with a peak SAR value greater than 0.5 W/Kg
- Probe: EX3DV4 - SN3977; ConvF(7.37, 7.37, 7.37); Calibrated: 2014/2/17;
- Sensor-Surface: 2mm (Mechanical Surface Detection)
- Electronics: DAE4 Sn779; Calibrated: 2014/2/25
- Phantom: ELI v5.0; Type: QDOVA002AA; Serial: TP:1133
- Measurement SW: DASYS2, Version 52.8 (7); SEMCAD X Version 14.6.10 (7164)

**Flat/Area Scan (81x121x1):**

Interpolated grid: dx=1.500 mm, dy=1.500 mm

Maximum value of SAR (interpolated) = 1.66 W/kg

**Flat/Zoom Scan (5x5x7)/Cube 0:**

Measurement grid: dx=8mm, dy=8mm, dz=5mm

Reference Value = 11.812 V/m; Power Drift = -0.04 dB

Peak SAR (extrapolated) = 1.92 W/kg

**SAR(1 g) = 1.12 W/kg; SAR(10 g) = 0.624 W/kg**

Maximum value of SAR (measured) = 1.52 W/kg

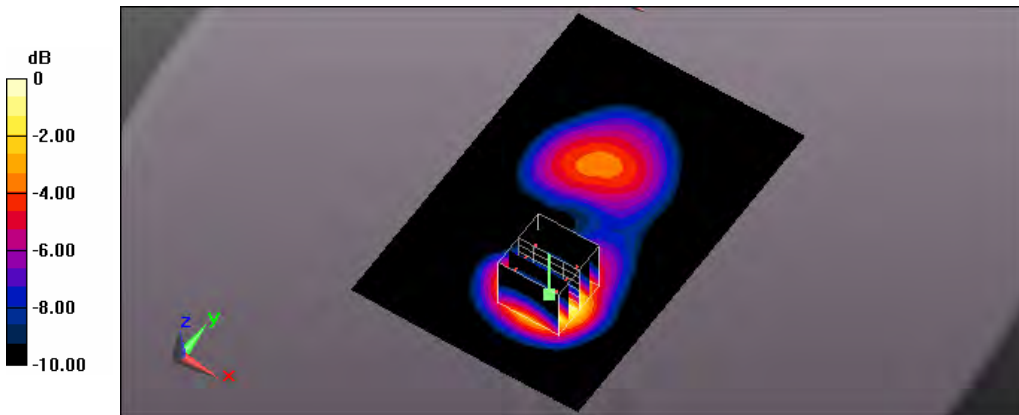

0 dB = 1.52 W/kg = 1.82 dBW/kg



Test Laboratory: A Test Lab Techno Corp.

Date: 2014/11/28 Time: AM 09:52:11

**54\_Flat\_LTE Band4 BW 20M CH20300\_QPSK with 1 RB Size 0 RB Offset\_original #36\_side 1 surface to phantom 10mm\_measurement once**

**DUT: AC779S-200; Type: Mobile Hot Spot; Serial: 01426000002034**

Communication System: UID 0, Generic LTE (0); Frequency: 1745 MHz; Duty Cycle: 1:1

Medium parameters used:  $f = 1745 \text{ MHz}$ ;  $\sigma = 1.527 \text{ S/m}$ ;  $\epsilon_r = 54.307$ ;  $\rho = 1000 \text{ kg/m}^3$

Phantom section: Flat Section

Measurement Standard: DASY5 (IEEE/IEC/ANSI C63.19-2011)

DASY Configuration:

- Area Scan setting - Find Secondary Maximum Within: 2.0dB and with a peak SAR value greater than 0.5 W/Kg
- Probe: EX3DV4 - SN3977; ConvF(7.69, 7.69, 7.69); Calibrated: 2014/2/17;
- Sensor-Surface: 2mm (Mechanical Surface Detection)
- Electronics: DAE4 Sn779; Calibrated: 2014/2/25
- Phantom: ELI v5.0; Type: QDOVA002AA; Serial: TP:1133
- Measurement SW: DASY52, Version 52.8 (7); SEMCAD X Version 14.6.10 (7164)

**Flat/Area Scan (81x121x1):**

Interpolated grid:  $dx=1.500 \text{ mm}$ ,  $dy=1.500 \text{ mm}$

Maximum value of SAR (interpolated) = 1.56 W/kg

**Flat/Zoom Scan (5x5x7)/Cube 0:**

Measurement grid:  $dx=8\text{mm}$ ,  $dy=8\text{mm}$ ,  $dz=5\text{mm}$

Reference Value = 13.700 V/m; Power Drift = 0.14 dB

Peak SAR (extrapolated) = 1.96 W/kg

**SAR(1 g) = 1.14 W/kg; SAR(10 g) = 0.613 W/kg**

Maximum value of SAR (measured) = 1.59 W/kg

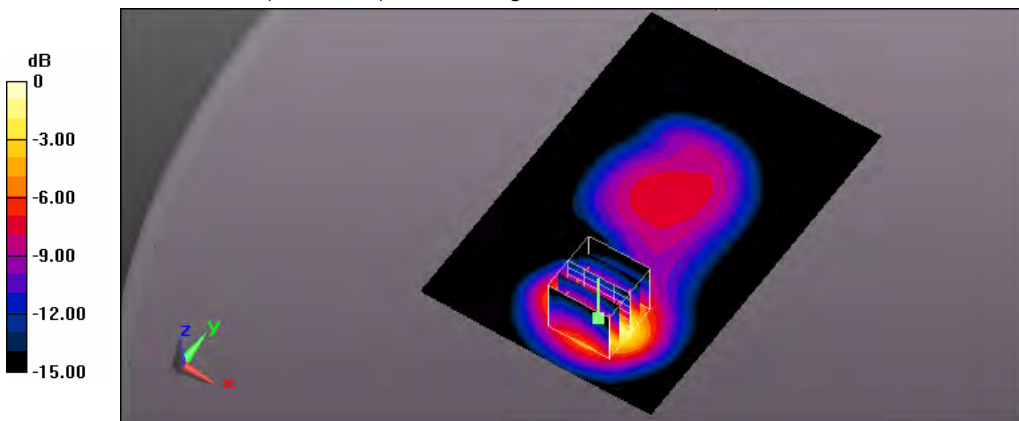

0 dB = 1.59 W/kg = 2.01 dBW/kg

Test Laboratory: A Test Lab Techno Corp.

Date: 2014/11/28 Time: AM 10:17:52

**55\_Flat\_LTE Band4 BW 20M CH20300\_QPSK with 1 RB Size 0 RB Offset\_original #36\_side 1 surface to phantom 10mm\_measurement second**

**DUT: AC779S-200; Type: Mobile Hot Spot; Serial: 01426000002034**

Communication System: UID 0, Generic LTE (0); Frequency: 1745 MHz; Duty Cycle: 1:1

Medium parameters used:  $f = 1745 \text{ MHz}$ ;  $\sigma = 1.527 \text{ S/m}$ ;  $\epsilon_r = 54.307$ ;  $\rho = 1000 \text{ kg/m}^3$

Phantom section: Flat Section

Measurement Standard: DASY5 (IEEE/IEC/ANSI C63.19-2011)

DASY Configuration:

- Area Scan setting - Find Secondary Maximum Within: 2.0dB and with a peak SAR value greater than 0.5 W/Kg
- Probe: EX3DV4 - SN3977; ConvF(7.69, 7.69, 7.69); Calibrated: 2014/2/17;
- Sensor-Surface: 2mm (Mechanical Surface Detection)
- Electronics: DAE4 Sn779; Calibrated: 2014/2/25
- Phantom: ELI v5.0; Type: QDOVA002AA; Serial: TP:1133
- Measurement SW: DASY52, Version 52.8 (7); SEMCAD X Version 14.6.10 (7164)

**Flat/Area Scan (81x121x1):**

Interpolated grid:  $dx=1.500 \text{ mm}$ ,  $dy=1.500 \text{ mm}$

Maximum value of SAR (interpolated) = 1.59 W/kg

**Flat/Zoom Scan (5x5x7)/Cube 0:**

Measurement grid:  $dx=8\text{mm}$ ,  $dy=8\text{mm}$ ,  $dz=5\text{mm}$

Reference Value = 13.741 V/m; Power Drift = 0.04 dB

Peak SAR (extrapolated) = 1.97 W/kg

**SAR(1 g) = 1.15 W/kg; SAR(10 g) = 0.615 W/kg**

Maximum value of SAR (measured) = 1.59 W/kg

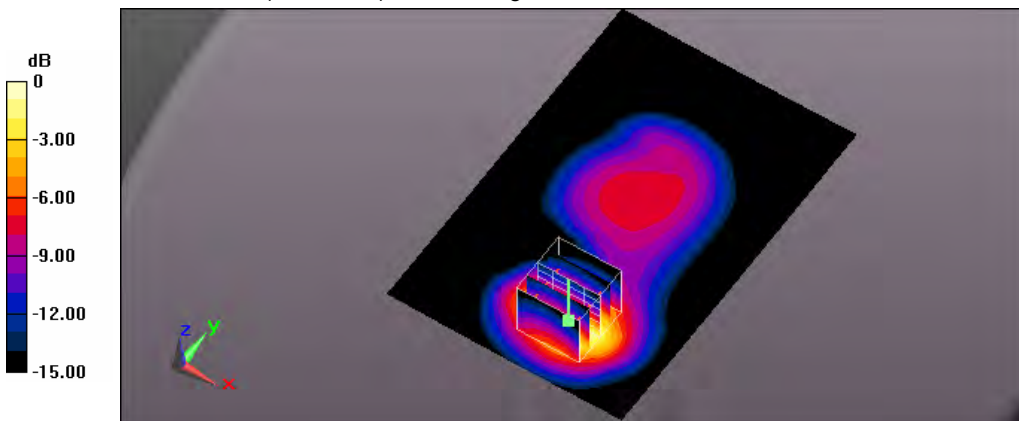

0 dB = 1.59 W/kg = 2.01 dBW/kg

Test Laboratory: A Test Lab Techno Corp.

Date: 2014/12/16 Time: PM 10:33:14

**99\_ Flat LTE Band4 BW 20M CH20300\_QPSK with 1 RB Size 0 RB Offset\_original #36\_side 1 surface to phantom 10mm\_measurement third**

**DUT: AC779S-200; Type: Mobile Hot Spot; Serial: 01426000002034**

Communication System: UID 0, Generic LTE (0); Frequency: 1745 MHz; Duty Cycle: 1:1

Medium parameters used:  $f = 1745 \text{ MHz}$ ;  $\sigma = 1.527 \text{ S/m}$ ;  $\epsilon_r = 54.307$ ;  $\rho = 1000 \text{ kg/m}^3$

Phantom section: Flat Section

Measurement Standard: DASYS (IEEE/IEC/ANSI C63.19-2011)

DASY Configuration:

- Area Scan setting - Find Secondary Maximum Within: 2.0dB and with a peak SAR value greater than 0.5 W/Kg
- Probe: EX3DV4 - SN3977; ConvF(7.69, 7.69, 7.69); Calibrated: 2014/2/17;
- Sensor-Surface: 2mm (Mechanical Surface Detection)
- Electronics: DAE4 Sn779; Calibrated: 2014/2/25
- Phantom: ELI v5.0; Type: QDOVA002AA; Serial: TP:1133
- Measurement SW: DASYS2, Version 52.8 (7); SEMCAD X Version 14.6.10 (7164)

**Flat/Area Scan (81x121x1):**

Interpolated grid:  $dx=1.500 \text{ mm}$ ,  $dy=1.500 \text{ mm}$

Maximum value of SAR (interpolated) = 1.61 W/kg

**Flat/Zoom Scan (5x5x7)/Cube 0:**

Measurement grid:  $dx=8\text{mm}$ ,  $dy=8\text{mm}$ ,  $dz=5\text{mm}$

Reference Value = 12.522 V/m; Power Drift = -0.14 dB

Peak SAR (extrapolated) = 1.95 W/kg

**SAR(1 g) = 1.13 W/kg; SAR(10 g) = 0.598 W/kg**

Maximum value of SAR (measured) = 1.56 W/kg

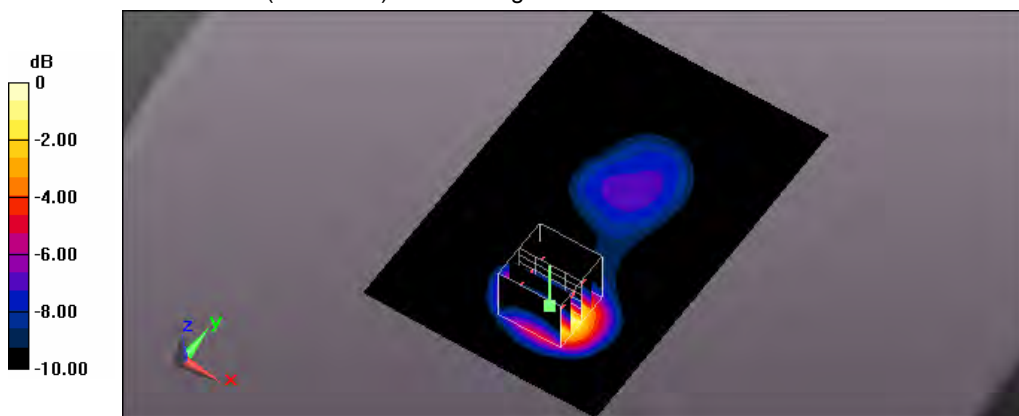

0 dB = 1.56 W/kg = 1.93 dBW/kg

Test Laboratory: A Test Lab Techno Corp.

Date: 2014/12/1 Time: PM 10:06:09

**91\_Flat\_LTE Band17 BW 10M CH23780\_QPSK with 1 RB Size 0 RB Offset\_original #71\_side 1 surface to phantom 10mm\_measurement once**

**DUT: AC779S-200; Type: Mobile Hot Spot; Serial: 01426000002034**

Communication System: UID 0, Generic LTE (0); Frequency: 709 MHz; Duty Cycle: 1:1

Medium parameters used:  $f = 709 \text{ MHz}$ ;  $\sigma = 0.94 \text{ S/m}$ ;  $\epsilon_r = 53.708$ ;  $\rho = 1000 \text{ kg/m}^3$

Phantom section: Flat Section

Measurement Standard: DASYS (IEEE/IEC/ANSI C63.19-2011)

DASY Configuration:

- Area Scan setting - Find Secondary Maximum Within: 2.0dB and with a peak SAR value greater than 0.5 W/Kg
- Probe: EX3DV4 - SN3977; ConvF(9.78, 9.78, 9.78); Calibrated: 2014/2/17;
- Sensor-Surface: 2mm (Mechanical Surface Detection)
- Electronics: DAE4 Sn779; Calibrated: 2014/2/25
- Phantom: ELI v5.0; Type: QDOVA002AA; Serial: TP:1133
- Measurement SW: DASYS2, Version 52.8 (7); SEMCAD X Version 14.6.10 (7164)

**Flat/Area Scan (81x121x1):**

Interpolated grid:  $dx=1.500 \text{ mm}$ ,  $dy=1.500 \text{ mm}$

Maximum value of SAR (interpolated) = 1.44 W/kg

**Flat/Zoom Scan (5x5x7)/Cube 0:**

Measurement grid:  $dx=8\text{mm}$ ,  $dy=8\text{mm}$ ,  $dz=5\text{mm}$

Reference Value = 33.554 V/m; Power Drift = -0.04 dB

Peak SAR (extrapolated) = 1.68 W/kg

**SAR(1 g) = 1.18 W/kg; SAR(10 g) = 0.822 W/kg**

Maximum value of SAR (measured) = 1.44 W/kg

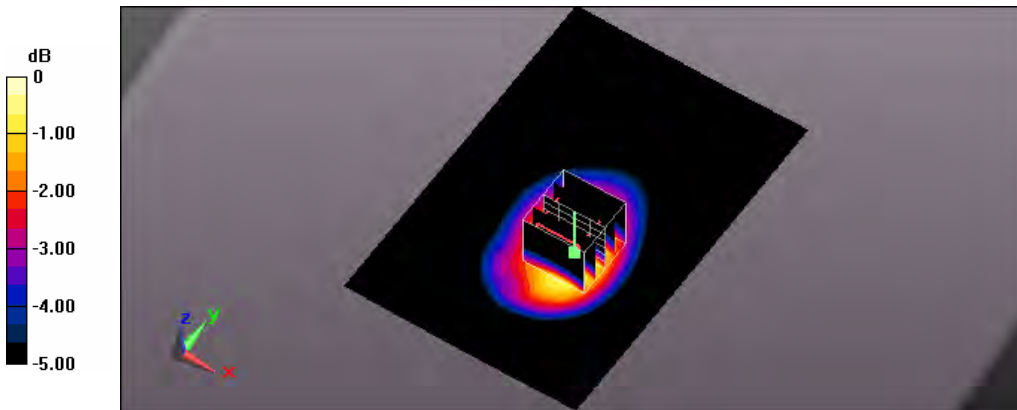

0 dB = 1.44 W/kg = 1.58 dBW/kg

Test Laboratory: A Test Lab Techno Corp.

Date: 2014/12/5 Time: PM 04:58:37

**94\_Flat\_802.11b\_CH1\_1M\_side 1 surface to phantom 10mm**

**DUT: AC779S-200; Type: Mobile Hot Spot; Serial: 01426000002034**

Communication System: UID 0, IEEE 802.11b (0); Frequency: 2412 MHz; Duty Cycle: 1:1

Medium parameters used:  $f = 2412 \text{ MHz}$ ;  $\sigma = 1.927 \text{ S/m}$ ;  $\epsilon_r = 53.982$ ;  $\rho = 1000 \text{ kg/m}^3$

Phantom section: Flat Section

Measurement Standard: DASY5 (IEEE/IEC/ANSI C63.19-2011)

DASY Configuration:

- Area Scan setting - Find Secondary Maximum Within: 2.0dB and with a peak SAR value greater than 0.5 W/Kg
- Probe: EX3DV4 - SN3977; ConvF(6.97, 6.97, 6.97); Calibrated: 2014/2/17;
- Sensor-Surface: 2mm (Mechanical Surface Detection)
- Electronics: DAE4 Sn779; Calibrated: 2014/2/25
- Phantom: ELI v5.0; Type: QDOVA002AA; Serial: TP:1133
- Measurement SW: DASY52, Version 52.8 (7); SEMCAD X Version 14.6.10 (7164)

**Flat/Area Scan (101x151x1):**

Interpolated grid:  $dx=1.000 \text{ mm}$ ,  $dy=1.000 \text{ mm}$

Maximum value of SAR (interpolated) = 0.0731 W/kg

**Flat/Zoom Scan (7x7x7)/Cube 0:**

Measurement grid:  $dx=5\text{mm}$ ,  $dy=5\text{mm}$ ,  $dz=5\text{mm}$

Reference Value = 2.847 V/m; Power Drift = -0.09 dB

Peak SAR (extrapolated) = 0.0950 W/kg

**SAR(1 g) = 0.046 W/kg; SAR(10 g) = 0.020 W/kg**

Maximum value of SAR (measured) = 0.0697 W/kg

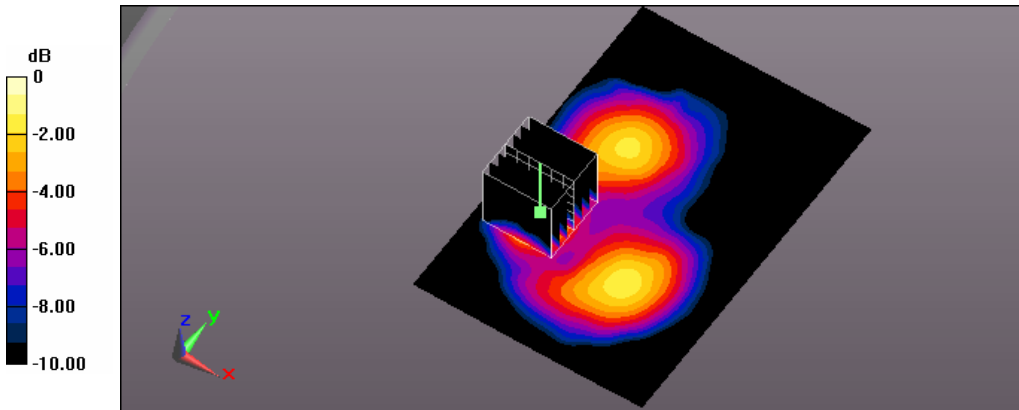

0 dB = 0.0697 W/kg = -11.57 dBW/kg

Test Laboratory: A Test Lab Techno Corp.

Date: 2014/12/5 Time: PM 05:37:09

**95\_Flat\_802.11b\_CH1\_1M\_side 3 surface to phantom 10mm**

**DUT: AC779S-200; Type: Mobile Hot Spot; Serial: 01426000002034**

Communication System: UID 0, IEEE 802.11b (0); Frequency: 2412 MHz; Duty Cycle: 1:1

Medium parameters used:  $f = 2412 \text{ MHz}$ ;  $\sigma = 1.927 \text{ S/m}$ ;  $\epsilon_r = 53.982$ ;  $\rho = 1000 \text{ kg/m}^3$

Phantom section: Flat Section

Measurement Standard: DASYS (IEEE/IEC/ANSI C63.19-2011)

DASY Configuration:

- Area Scan setting - Find Secondary Maximum Within: 2.0dB and with a peak SAR value greater than 0.5 W/Kg
- Probe: EX3DV4 - SN3977; ConvF(6.97, 6.97, 6.97); Calibrated: 2014/2/17;
- Sensor-Surface: 2mm (Mechanical Surface Detection)
- Electronics: DAE4 Sn779; Calibrated: 2014/2/25
- Phantom: ELI v5.0; Type: QDOVA002AA; Serial: TP:1133
- Measurement SW: DASYS2, Version 52.8 (7); SEMCAD X Version 14.6.10 (7164)

**Flat/Area Scan (91x161x1):**

Interpolated grid:  $dx=1.000 \text{ mm}$ ,  $dy=1.000 \text{ mm}$

Maximum value of SAR (interpolated) = 0.0447 W/kg

**Flat/Zoom Scan (7x7x7)/Cube 0:**

Measurement grid:  $dx=5\text{mm}$ ,  $dy=5\text{mm}$ ,  $dz=5\text{mm}$

Reference Value = 3.458 V/m; Power Drift = 0.01 dB

Peak SAR (extrapolated) = 0.0580 W/kg

**SAR(1 g) = 0.031 W/kg; SAR(10 g) = 0.016 W/kg**

Maximum value of SAR (measured) = 0.0441 W/kg

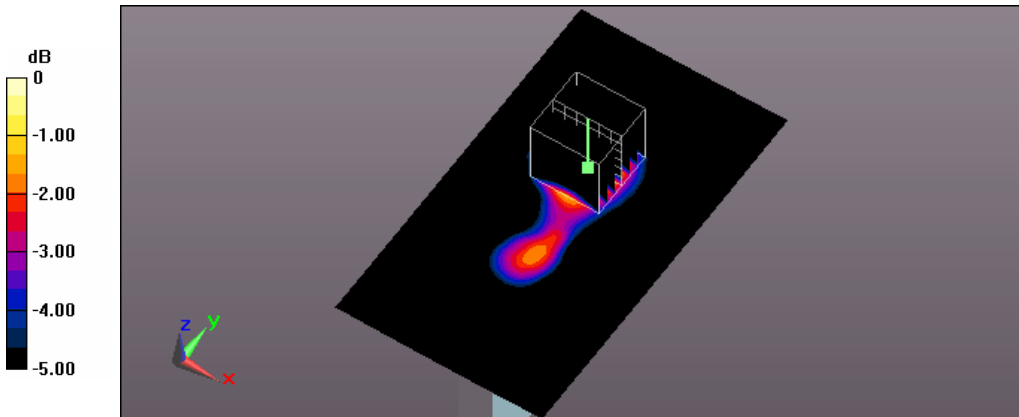

0 dB = 0.0441 W/kg = -13.56 dBW/kg