

FCC 47 CFR PART 15 SUBPART C

Product Type : Mobile Hot Spot
Applicant : Netgear Inc.
Address : 350 East Plumeria Drive, San Jose, CA 95134
Trade Name : Netgear
Model Number : AC779S-200
Test Specification : FCC 47 CFR PART 15 SUBPART C: Oct., 2013
ANSI C63.4:2014
Receive Date : Nov. 19, 2014
Test Period : Dec. 03 ~ Dec. 10, 2014
Issue Date : Jan. 19, 2015

Issue by

A Test Lab Techno Corp.
No. 140-1, Changan Street, Bade City,
Taoyuan County 334, Taiwan R.O.C.
Tel : +886-3-2710188 / Fax : +886-3-2710190



Taiwan Accreditation Foundation accreditation number: 1330

Note: This report shall not be reproduced except in full, without the written approval of A Test Lab Techno Corp. This document may be altered or revised by A Test Lab Techno Corp. personnel only, and shall be noted in the revision section of the document. The client should not use it to claim product endorsement by TAF, or any government agencies. The test results in the report only apply to the tested sample.

Revision History

Rev.	Issue Date	Revisions	Revised By
00	Jan. 19, 2015	Initial Issue	

Verification of Compliance

Issued Date: 01/19/2015

Product Type : Mobile Hot Spot
Applicant : Netgear Inc.
Address : 350 East Plumeria Drive, San Jose, CA 95134
Trade Name : Netgear
Model Number : AC779S-200
FCC ID : PY3AC779S
EUT Rated Voltage : DC 5V, 1.0A
Test Voltage : 120 Vac / 60 Hz
Applicable Standard : FCC 47 CFR PART 15 SUBPART C: Oct., 2013
ANSI C63.4:2014
Test Result : Complied
Performing Lab. : A Test Lab Techno Corp.

No. 140-1, Changan Street, Bade City,
Taoyuan County 334, Taiwan R.O.C.

Tel : +886-3-2710188 / Fax : +886-3-2710190

Taiwan Accreditation Foundation accreditation number: 1330

<http://www.atl-lab.com.tw/e-index.htm>



The above equipment was tested by A Test Lab Techno Corp. The test data, data evaluation, test procedures, and equipment configurations shown in this report were made in accordance with the procedures given in ANSI C63.4:2014 and the energy emitted by the sample tested as described in this report is in compliance with the requirements of FCC Rules Part 15.207, 15.209, 15.247 .

The test results of this report relate only to the tested sample identified in this report.

Approved By



(Manager)

(Fly Lu)

Reviewed By



(Testing Engineer)

(Eric Ou Yang)

TABLE OF CONTENTS

1	General Information	6
2	EUT Description	7
3	Test Methodology	8
	3.1. Mode of Operation.....	8
	3.2. EUT Exercise Software	8
	3.3. Configuration of Test System Details	9
	3.4. Test Site Environment	9
4	Conducted Emission Measurement	10
	4.1. Limit	10
	4.2. Test Instruments	10
	4.3. Test Setup.....	10
	4.4. Test Procedure	11
	4.5. Test Result.....	12
5	Radiated Emission Measurement.....	14
	5.1. Limit	14
	5.2. Test Instruments	14
	5.3. Setup	15
	5.4. Test Procedure	16
	5.5. Test Result.....	18
6	Maximum Conducted Output Power Measurement.....	25
	6.1. Limit	25
	6.2. Test Setup.....	25
	6.3. Test Instruments	25
	6.4. Test Procedure	25
	6.5. Test Result.....	26
7	6dB RF Bandwidth and 99 % Occupied Bandwidth Measurement	28
	7.1. Limit	28
	7.2. Test Setup.....	28
	7.3. Test Instruments	28
	7.4. Test Procedure	28
	7.5. Test Result.....	29
	7.6. Test Graphs	30
8	Maximum Power Density Measurement	34
	8.1. Limit	34
	8.2. Test Setup.....	34
	8.3. Test Instruments	34
	8.4. Test Procedure	34
	8.5. Test Result.....	35
	8.6. Test Graphs	36

9	Out of Band Conducted Emissions Measurement	40
9.1.	Limit	40
9.2.	Test Setup.....	40
9.3.	Test Instruments	40
9.4.	Test Procedure	40
9.5.	Test Graphs	41
10	Band Edges Measurement	53
10.1.	Limit	53
10.2.	Test Setup.....	53
10.3.	Test Instruments	53
10.4.	Test Procedure	54
10.5.	Test Result.....	55
11	Antenna Measurement.....	59
11.1.	Limit	59
11.2.	Antenna Connector Construction	59

1 General Information

1.1 Summary of Test Result

Standard	Item	Result	Remark
15.247			
15.207	AC Power Conducted Emission	PASS	-----
Standard	Item	Result	Remark
15.247			
15.247(d)	Transmitter Radiated Emissions	PASS	-----
15.247(b)(3)	Max. Output Power	PASS	-----
15.247(a)(2)	6dB RF Bandwidth	PASS	-----
15.247(e)	Power Spectral Density	PASS	-----
15.247(d)	Out of Band Conducted Spurious Emission	PASS	-----
15.247(d)	Band Edge Measurement	PASS	-----
15.203	Antenna Requirement	PASS	-----

The test results of this report relate only to the tested sample(s) identified in this report. Manufacturer or whom it may concern should recognize the pass or fail of the test result.

1.2 Measurement Uncertainty

Test Item	Frequency Range	Uncertainty (dB)	
Conducted Emission	9kHz ~ 30MHz	± 2.02	
Radiated Emission	30MHz ~ 1000MHz	Horizontal	± 3.98
		Vertical	± 3.62
	1000MHz ~ 18000MHz	Horizontal	± 3.11
		Vertical	± 3.07
	18000MHz ~ 40000MHz	Horizontal	± 3.66
		Vertical	± 3.54

2 EUT Description

Product Type	Mobile Hot Spot
Trade Name	Netgear
Model No.	AC779S-200
Applicant	Netgear Inc. 350 East Plumeria Drive, San Jose, CA 95134
Manufacturer	Netgear Inc. Suite 168 – 10760 Shellbridge Way, Richmond, BC Canada V6X 3H1
IMEI No.	014260000002034
Hardware Version	REV.2
Software Version	FXC9X15B_45.00.03.01_MFG
FCC ID	PY3AC779S
Frequency Range	IEEE 802.11b / 802.11g / 802.11n 2.4GHz 20MHz: 2412 ~ 2462 MHz IEEE 802.11n 2.4GHz 40MHz: 2422 ~ 2452 MHz
Modulation Type	IEEE 802.11b:DSSS IEEE 802.11g:DSSS + OFDM IEEE 802.11n 2.4GHz 20MHz: OFDM IEEE 802.11n 2.4GHz 40MHz: OFDM
Antenna Type	FPC Antenna
Antenna Gain	1.45 dBi
Antenna Delivery	1TX + 1RX
RF Output Power	IEEE 802.11b: 0.018 W / 12.52 dBm IEEE 802.11g: 0.078 W / 18.93 dBm IEEE 802.11n 2.4GHz 20MHz: 0.090 W / 19.55 dBm IEEE 802.11n 2.4GHz 40MHz: 0.081 W / 19.07 dBm

3 Test Methodology

3.1. Mode of Operation

Decision of Test ATL has verified the construction and function in typical operation. All the test modes were carried out with the EUT in normal operation, which was shown in this test report and defined as:

Test Mode
Mode 1: Normal Operation Mode
Mode 2: IEEE 802.11b Link Mode
Mode 3: IEEE 802.11g Link Mode
Mode 4: IEEE 802.11n 2.4GHz 20MHz Link Mode
Mode 5: IEEE 802.11n 2.4GHz 40MHz Link Mode

Software used to control the EUT for staying in continuous transmitting mode was programmed.

After verification, all tests were carried out with the worst case test modes as shown below except radiated spurious emission below 1GHz and power line conducted emissions below 30MHz, which worst case was in normal link mode only.

IEEE 802.11b mode:

Channel Low (2412MHz), Channel Mid (2437MHz) and Channel High (2462MHz) with 1Mbps data rate were chosen for full testing.

IEEE 802.11g mode:

Channel Low (2412MHz), Channel Mid (2437MHz) and Channel High (2462MHz) with 6Mbps data rate were chosen for full testing.

IEEE 802.11n 2.4GHz 20MHz mode:

Channel Low (2412MHz), Channel Mid (2437MHz) and Channel High (2462MHz) with 6.5Mbps data rate were chosen for full testing.

IEEE 802.11n 2.4GHz 40MHz mode:

Channel Low (2422MHz), Channel Mid (2437MHz) and Channel High (2452MHz) with 13.5Mbps data rate were chosen for full testing.

3.2. EUT Exercise Software

1. Setup the EUT shown on 3.3.
2. Turn on the power of all equipment.
3. Turn on Wi-Fi function link to AP.
4. EUT run test program.

3.3. Configuration of Test System Details

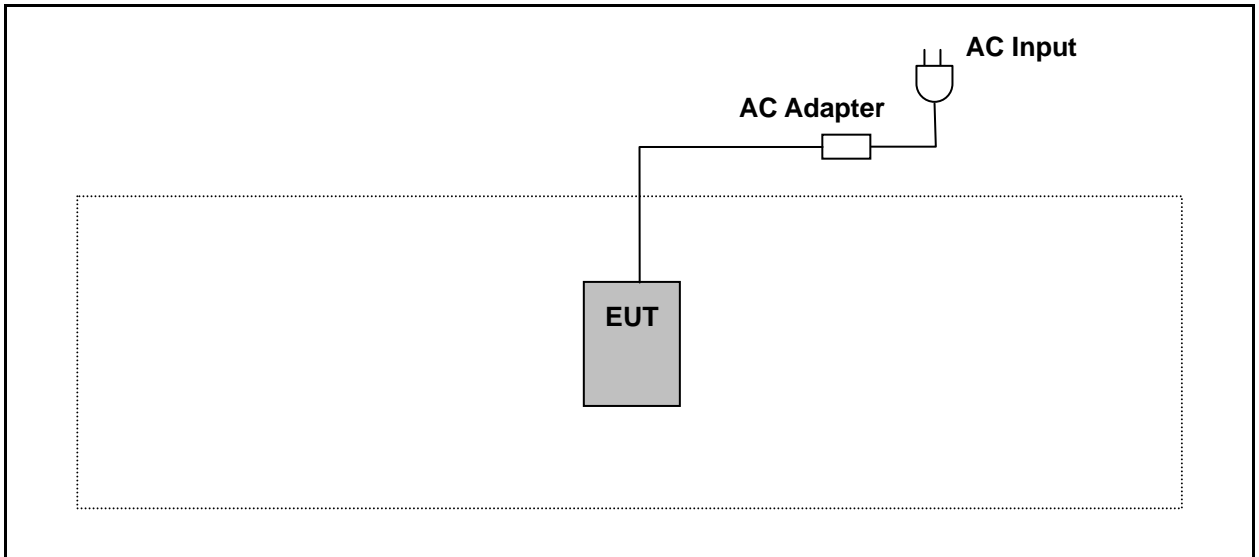

3.4. Test Site Environment

Items	Required (IEC 60068-1)	Actual
Temperature (°C)	15-35	26
Humidity (%RH)	25-75	60
Barometric pressure (mbar)	860-1060	950

4 Conducted Emission Measurement

4.1. Limit

Frequency (MHz)	Quasi-peak	Average
0.15 - 0.5	66 to 56	56 to 46
0.50 - 5.0	56	46
5.0 - 30.0	60	50

4.2. Test Instruments

Describe	Manufacturer	Model Number	Serial Number	Cal. Date	Remark
Test Receiver	R&S	ESCI	100367	06/12/2014	(1)
LISN	R&S	ENV216	101040	03/07/2014	(1)
LISN	R&S	ENV216	101041	03/07/2014	(1)
Test Site	ATL	TE02	TE02	N.C.R.	-----

Remark: (1) Calibration period 1 year. (2) Calibration period 2 years. (3) Calibration period 3 years.

Note: N.C.R. = No Calibration Request.

4.3. Test Setup

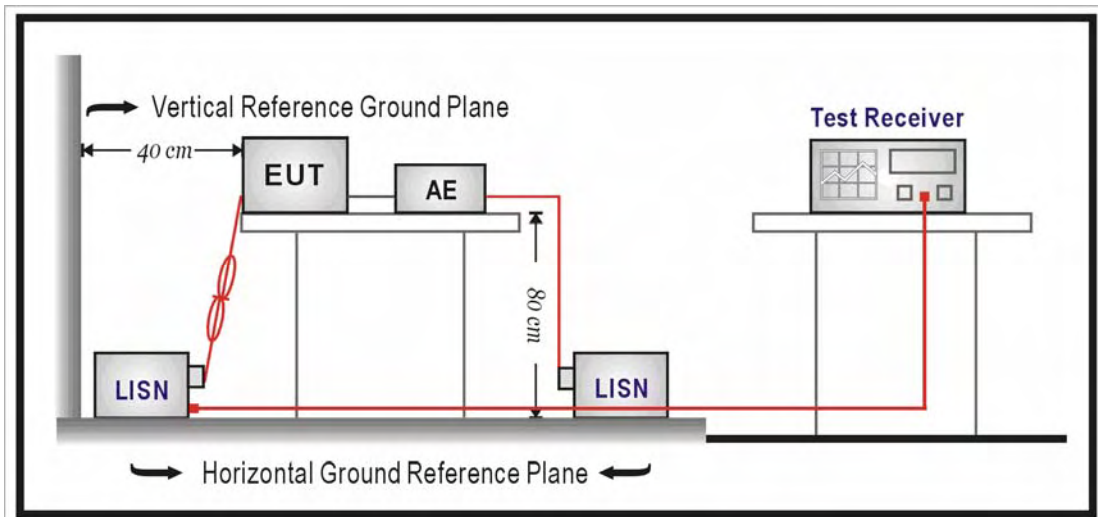

4.4. Test Procedure

The power line conducted emission measurements were performed in a shielded enclosure. The EUT was assembled on a wooden table which is 80 centimeters high, was placed 40 centimeters from the back wall and at least 1 meter from the sidewall.

Power was fed to the EUT from the public utility power grid through a line filter and EMCO Model 3162/2 SH Line Impedance Stabilization Networks (LISN). The LISN housing, measuring instrumentation case, ground plane, etc., were electrically bonded together at the same RF potential. The Spectrum analyzer was connected to the AC line through an isolation transformer. The 50-ohm output of the LISN was connected to the spectrum analyzer directly. Conducted emission levels were in the CISPR quasi-peak detection mode. The analyzer's 6 dB bandwidth was set to 9 KHz. No post-detector video filter was used.

The spectrum was scanned from 150 KHz to 30 MHz. The physical arrangement of the test system and associated cabling was varied (within the scope of arrangements likely to be encountered in actual use) to determine the effect on the unit's emanations in amplitude and frequency. All spurious emission frequencies were observed. The highest emission amplitudes relative to the appropriate limit were measured and have been recorded in paragraph 4.1.

4.5. Test Result

Standard:	FCC Part 15C	Line:	L1
Test item:	Conducted Emission	Power:	AC 120V/60Hz
Model Number:	AC779S-200	Temp.(°C)/Hum.(%RH):	26(°C)/60%RH
Mode:	1	Date:	12/10/2014
		Test By:	Eric Ou Yang
Description:			

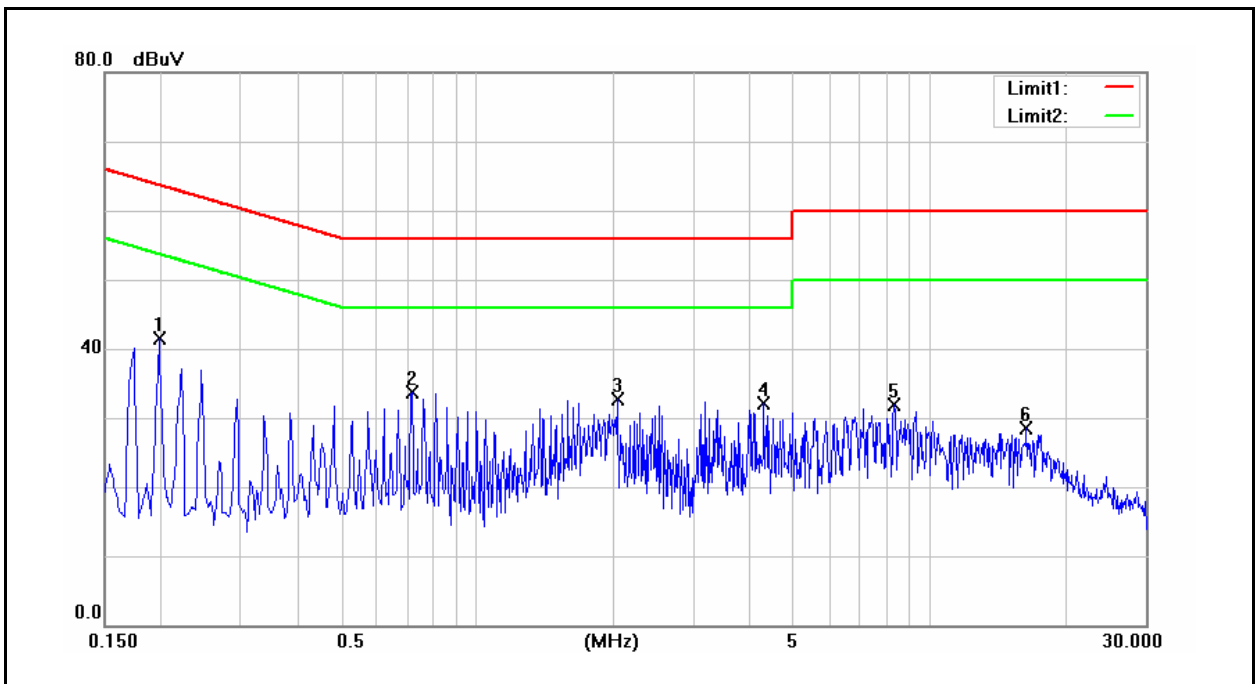

No.	Frequency (MHz)	QP reading (dBuV)	AVG reading (dBuV)	Correction factor (dB)	QP result (dBuV)	AVG result (dBuV)	QP limit (dBuV)	AVG limit (dBuV)	QP margin (dB)	AVG margin (dB)	Remark
1	0.1980	23.47	8.92	9.60	33.07	18.52	63.69	53.69	-30.62	-35.17	Pass
2	0.7180	18.50	7.01	9.62	28.12	16.63	56.00	46.00	-27.88	-29.37	Pass
3	2.0340	13.76	6.21	9.69	23.45	15.90	56.00	46.00	-32.55	-30.10	Pass
4	4.3100	11.32	3.99	9.77	21.09	13.76	56.00	46.00	-34.91	-32.24	Pass
5	8.3420	9.17	3.49	9.90	19.07	13.39	60.00	50.00	-40.93	-36.61	Pass
6	16.3420	9.90	1.16	10.14	20.04	11.30	60.00	50.00	-39.96	-38.70	Pass

Note: 1. Result (dBuV) = Correction factor (dB) + Reading(dBuV).

2. Correction factor (dB) = Cable loss (dB) + L.I.S.N. factor (dB).

Standard:	FCC Part 15C	Line:	N
Test item:	Conducted Emission	Power:	AC 120V/60Hz
Model Number:	AC779S-200	Temp.(°C)/Hum.(%RH):	26(°C)/60%RH
Mode:	1	Date:	12/10/2014
		Test By:	Eric Ou Yang
Description:			

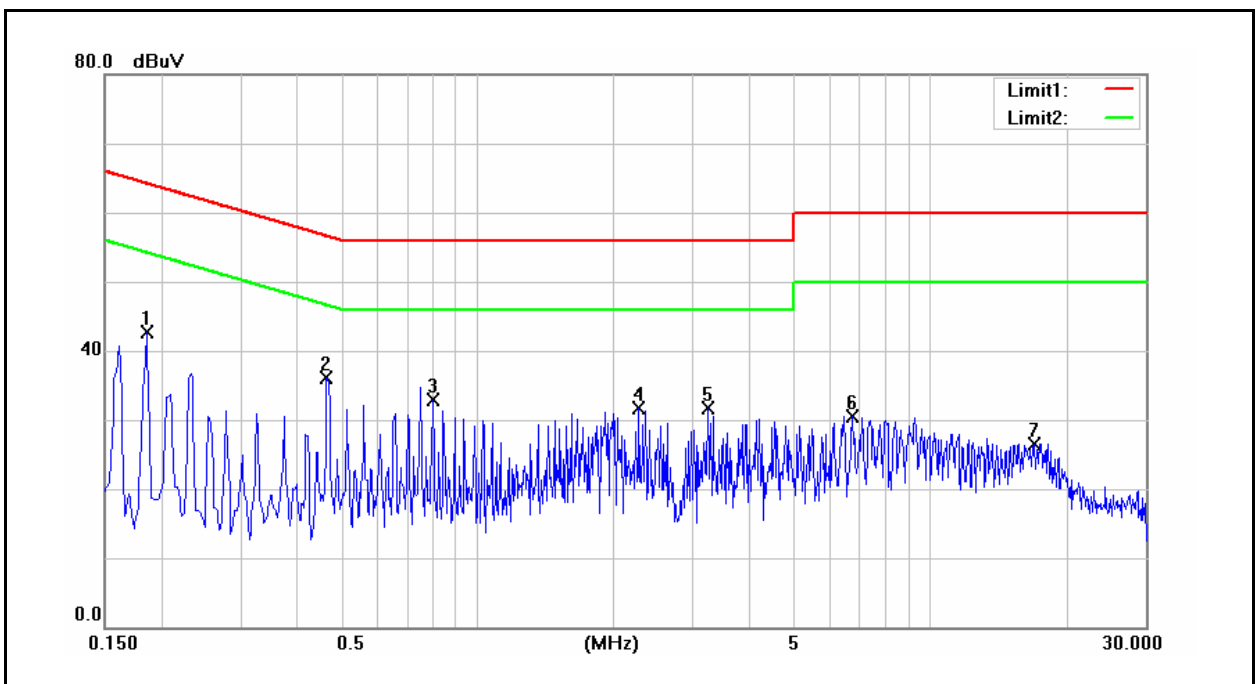

No.	Frequency (MHz)	QP reading (dBuV)	AVG reading (dBuV)	Correction factor (dB)	QP result (dBuV)	AVG result (dBuV)	QP limit (dBuV)	AVG limit (dBuV)	QP margin (dB)	AVG margin (dB)	Remark
1	0.1860	24.97	9.17	9.60	34.57	18.77	64.21	54.21	-29.64	-35.44	Pass
2	0.4660	20.80	7.71	9.62	30.42	17.33	56.58	46.58	-26.16	-29.25	Pass
3	0.7980	18.01	6.14	9.64	27.65	15.78	56.00	46.00	-28.35	-30.22	Pass
4	2.2820	14.11	5.60	9.71	23.82	15.31	56.00	46.00	-32.18	-30.69	Pass
5	3.2380	14.87	5.45	9.77	24.64	15.22	56.00	46.00	-31.36	-30.78	Pass
6	6.7500	10.77	4.19	9.88	20.65	14.07	60.00	50.00	-39.35	-35.93	Pass
7	17.0500	6.95	0.03	10.16	17.11	10.19	60.00	50.00	-42.89	-39.81	Pass

Note: 1. Result (dBuV) = Correction factor (dB) + Reading(dBuV).

2. Correction factor (dB) = Cable loss (dB) + L.I.S.N. factor (dB).

5 Radiated Emission Measurement

5.1. Limit

According to §15.209(a), except as provided elsewhere in this subpart, the emissions from an intentional radiator shall not exceed the field strength levels specified in the following table:

Frequency (MHz)	Field Strength ($\mu\text{V}/\text{m}$ at meter)	Measurement Distance (meters)
0.009 – 0.490	2400 / F (kHz)	300
0.490 – 1.705	24000 / F (kHz)	30
1.705 – 30.0	30	30
30 - 88	100**	3
88-216	150**	3
216-960	200**	3
Above 960	500	3

** Except as provided in paragraph (g), fundamental emissions from intentional radiators operating under this Section shall not be located in the frequency bands 54-72 MHz, 76-88 MHz, 174-216 MHz or 470-806 MHz. However, operation within these frequency bands is permitted under other sections of this Part, e.g., Sections 15.231 and 15.241.

5.2. Test Instruments

3 Meter Chamber					
Equipment	Manufacturer	Model Number	Serial Number	Cal. Date	Remark
RF Pre-selector	Agilent	N9039A	MY46520256	01/10/2014	(1)
Spectrum Analyzer	Agilent	E4446A	MY46180578	01/10/2014	(1)
Pre Amplifier	Agilent	8449B	3008A02237	02/21/2014	(1)
Pre Amplifier	Agilent	8447D	2944A10961	02/21/2014	(1)
Broadband Antenna (30MHz~1GHz)	SCHWARZBECK MESS-ELEKTRONIK	VULB9163	9163-270	07/22/2014	(1)
Horn Antenna (1~18GHz)	SCHWARZBECK MESS-ELEKTRONIK	BBHA9120D	9120D-550	06/11/2014	(1)
Horn Antenna (18~40GHz)	SCHWARZBECK MESS-ELEKTRONIK	BBHA9170	9170-320	07/02/2014	(1)
Loop Antenna	COM-POWER CORPORATION	AL-130	121014	01/28/2014	(1)
Test Site	ATL	TE01	888001	08/28/2014	(1)

Remark: (1) Calibration period 1 year. (2) Calibration period 2 years. (3) Calibration period 3 years.

Note: N.C.R. = No Calibration Request.

5.3. Setup

Below 1GHz

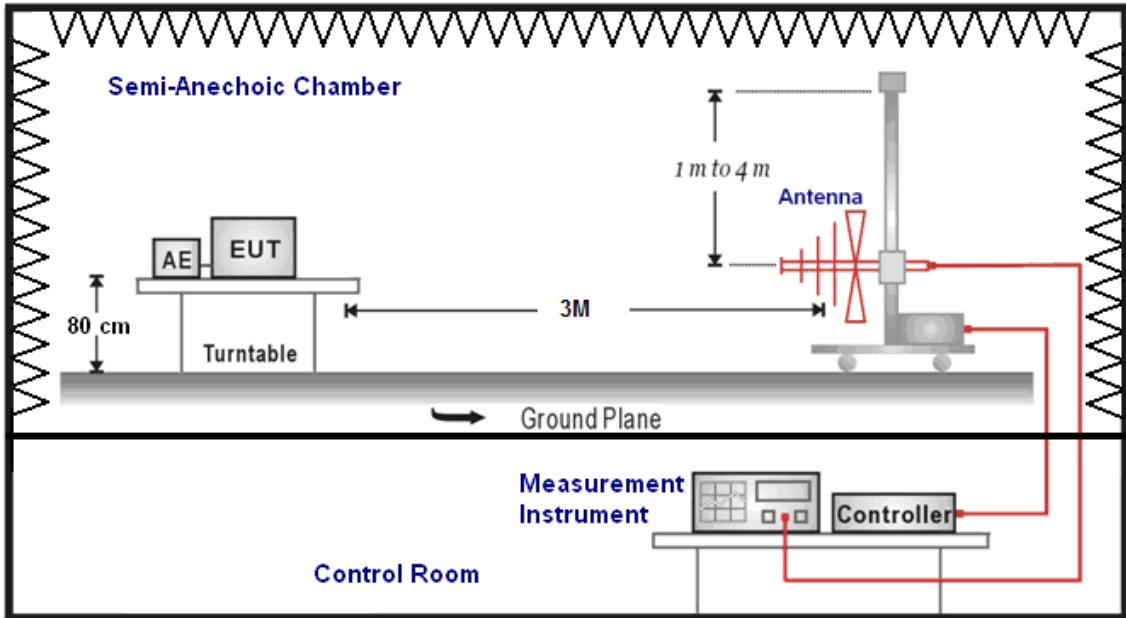

Above 1GHz

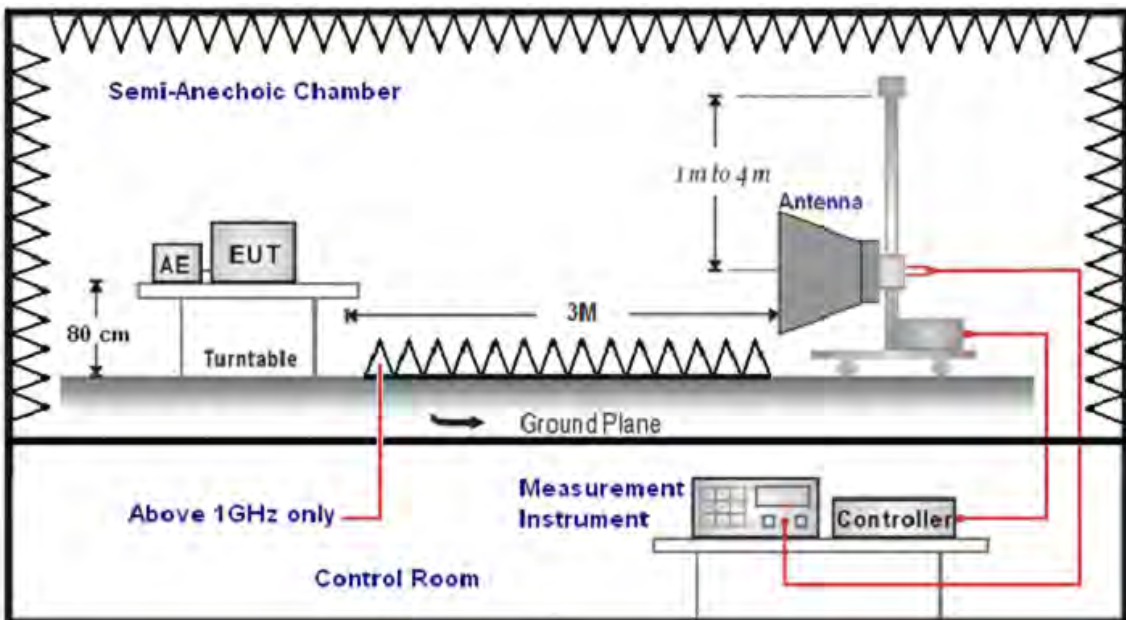

5.4. Test Procedure

Final radiation measurements were made on a three-meter, Semi Anechoic Chamber. The EUT system was placed on a nonconductive turntable which is 0.8 meters height, top surface 1.0 x 1.5 meter. The spectrum was examined from 250 MHz to 2.5 GHz in order to cover the whole spectrum below 10th harmonic which could generate from the EUT. During the test, EUT was set to transmit continuously & Measurements spectrum range from 9 kHz to 26.5 GHz is investigated.

For measurements below 1 GHz the resolution bandwidth is set to 100 kHz for peak detection measurements or 120 kHz for quasi-peak detection measurements. Peak detection is used unless otherwise noted as quasi-peak.

For measurements above 1 GHz the resolution bandwidth is set to 1 MHz, and then the video bandwidth is set to 1 MHz for peak measurements and 10 Hz for average measurements.

A nonconductive material surrounded the EUT to supporting the EUT for standing on three orthogonal planes. At each condition, the EUT was rotated 360 degrees, and the antenna was raised and lowered from one to four meters to find the maximum emission levels. Measurements were taken using both horizontal and vertical antenna polarization.

SCHWARZBECK MESS-ELEKTRONIK Biconilog Antenna (mode VULB9163) at 3 Meter and the SCHWARZBECK Double Ridged Guide Antenna (model BBHA9120D&9170) was used in frequencies 1 – 26.5 GHz at a distance of 1 meter. All test results were extrapolated to equivalent signal at 3 meters utilizing an inverse linear distance extrapolation Factor (20dB/decade).

For testing above 1GHz, the emission level of the EUT in peak mode was 20dB lower than average limit (that means the emission level in peak mode also complies with the limit in average mode), then testing will be stopped and peak values of EUT will be reported, otherwise, the emissions will be measured in average mode again and reported.

Appropriate preamplifiers were used for improving sensitivity and precautions were taken to avoid overloading or desensitizing the spectrum analyzer. No post – detector video filters were used in the test.

The spectrum analyzer's 6 dB bandwidth was set to 1 MHz, and the analyzer was operated in the peak detection mode, for frequencies both below and up 1 GHz. The average levels were obtained by subtracting the duty cycle correction factor from the peak readings.

The following procedures were used to convert the emission levels measured in decibels referenced to 1 microvolt (dBuV) into field intensity in micro volts pre meter (uV/m).

The actual field intensity in decibels referenced to 1 microvolt in to field intensity in micro volts per meter (dBuV/m).

The actual field intensity in referenced to 1 microvolt per meter (dBuV/m) is determined by algebraically adding the measured reading in dBuV, the antenna factor (dB), and cable loss (dB) and Subtracting the gain of preamplifier (dB) is auto calculate in spectrum analyzer.

(1) $\text{Amplitude (dBuV/m)} = \text{FI (dBuV)} + \text{AF (dBuV)} + \text{CL (dBuV)} - \text{Gain (dB)}$

FI= Reading of the field intensity.

AF= Antenna factor.

CL= Cable loss.

P.S Amplitude is auto calculate in spectrum analyzer.

(2) $\text{Actual Amplitude (dBuV/m)} = \text{Amplitude (dBuV)} - \text{Dis(dB)}$

The FCC specified emission limits were calculated according the EUT operating frequency and by following linear interpolation equations:

(a) For fundamental frequency : Transmitter Output < +30dBm

(b) For spurious frequency : Spurious emission limits = fundamental emission limit /10

Data of measurement within this frequency range without mark in the table above means the reading of emissions are attenuated more than 20dB below the permissible limits or the field strength is too small to be measured.

5.5. Test Result

Below 1GHz

Standard:	FCC Part 15C	Test Distance:	3m
Test item:	Radiated Emission	Power:	AC 120V/60Hz
Model Number:	AC779S-200	Temp.(°C)/Hum.(%RH):	26(°C)/60%RH
Mode:	1	Date:	12/05/2014
		Test By:	Eric Ou Yang

Frequency (MHz)	Reading (dBuV)	Correct Factor (dB/m)	Result (dBuV/m)	Limit (dBuV/m)	Margin (dB)	Remark	Ant.Polar. H / V
167.0000	34.14	-12.26	21.88	43.50	-21.62	QP	H
384.0000	33.66	-8.84	24.82	46.00	-21.18	QP	H
533.0000	28.29	-5.96	22.33	46.00	-23.67	QP	H
668.0000	29.03	-3.20	25.83	46.00	-20.17	QP	H
768.0000	27.71	-1.08	26.63	46.00	-19.37	QP	H
886.5000	25.00	1.16	26.16	46.00	-19.84	QP	H
142.5000	39.78	-12.25	27.53	43.50	-15.97	QP	V
320.5000	38.01	-10.13	27.88	46.00	-18.12	QP	V
401.0000	38.18	-8.48	29.70	46.00	-16.30	QP	V
568.0000	33.13	-5.14	27.99	46.00	-18.01	QP	V
687.5000	31.39	-2.85	28.54	46.00	-17.46	QP	V
887.5000	27.25	1.19	28.44	46.00	-17.56	QP	V

Note: No emission found between lowest internal used/generated frequency to 30MHz (9kHz~30MHz).

Above 1GHz

Standard:	FCC Part 15C	Test Distance:	3m
Test item:	Radiated Emission	Power:	AC 120V/60Hz
Model Number:	AC779S-200	Temp.(°C)/Hum.(%RH):	26(°C)/60%RH
Mode:	2	Date:	12/04/2014
Frequency:	2412MHz	Test By:	Eric Ou Yang

Frequency (MHz)	Reading (dBuV)	Correct Factor (dB/m)	Result (dBuV/m)	Limit (dBuV/m)	Margin (dB)	Remark	Ant.Polar. H / V
3009.000	37.53	-0.51	37.02	74.00	-36.98	peak	H
4619.000	34.85	4.10	38.95	74.00	-35.05	peak	H
6649.000	33.30	9.39	42.69	74.00	-31.31	peak	H
3051.000	37.99	-0.40	37.59	74.00	-36.41	peak	V
4598.000	34.56	4.04	38.60	74.00	-35.40	peak	V
6642.000	33.86	9.37	43.23	74.00	-30.77	peak	V

Standard:	FCC Part 15C	Test Distance:	3m
Test item:	Radiated Emission	Power:	AC 120V/60Hz
Model Number:	AC779S-200	Temp.(°C)/Hum.(%RH):	26(°C)/60%RH
Mode:	2	Date:	12/04/2014
Frequency:	2437MHz	Test By:	Eric Ou Yang

Frequency (MHz)	Reading (dBuV)	Correct Factor (dB/m)	Result (dBuV/m)	Limit (dBuV/m)	Margin (dB)	Remark	Ant.Polar. H / V
3037.000	37.68	-0.44	37.24	74.00	-36.76	peak	H
4549.000	33.41	3.92	37.33	74.00	-36.67	peak	H
6698.000	33.78	9.53	43.31	74.00	-30.69	peak	H
3037.000	36.96	-0.44	36.52	74.00	-37.48	peak	V
4591.000	33.75	4.01	37.76	74.00	-36.24	peak	V
6691.000	33.89	9.50	43.39	74.00	-30.61	peak	V

Standard:	FCC Part 15C		Test Distance:	3m			
Test item:	Radiated Emission		Power:	AC 120V/60Hz			
Model Number:	AC779S-200		Temp.(°C)/Hum.(%RH):	26(°C)/60%RH			
Mode:	2		Date:	12/04/2014			
Frequency:	2462MHz		Test By:	Eric Ou Yang			
Frequency (MHz)	Reading (dBuV)	Correct Factor (dB/m)	Result (dBuV/m)	Limit (dBuV/m)	Margin (dB)	Remark	Ant.Polar. H / V
3051.000	37.42	-0.40	37.02	74.00	-36.98	peak	H
4549.000	33.41	3.92	37.33	74.00	-36.67	peak	H
6649.000	33.25	9.39	42.64	74.00	-31.36	peak	H
3037.000	37.89	-0.44	37.45	74.00	-36.55	peak	V
4577.000	33.85	3.98	37.83	74.00	-36.17	peak	V
6649.000	33.79	9.39	43.18	74.00	-30.82	peak	V

Standard:	FCC Part 15C		Test Distance:	3m			
Test item:	Radiated Emission		Power:	AC 120V/60Hz			
Model Number:	AC779S-200		Temp.(°C)/Hum.(%RH):	26(°C)/60%RH			
Mode:	3		Date:	12/04/2014			
Frequency:	2412MHz		Test By:	Eric Ou Yang			
Frequency (MHz)	Reading (dBuV)	Correct Factor (dB/m)	Result (dBuV/m)	Limit (dBuV/m)	Margin (dB)	Remark	Ant.Polar. H / V
3023.000	36.88	-0.48	36.40	74.00	-37.60	peak	H
4570.000	33.88	3.97	37.85	74.00	-36.15	peak	H
6698.000	33.12	9.53	42.65	74.00	-31.35	peak	H
3058.000	36.19	-0.38	35.81	74.00	-38.19	peak	V
4605.000	34.33	4.05	38.38	74.00	-35.62	peak	V
6670.000	33.73	9.45	43.18	74.00	-30.82	peak	V

Standard:	FCC Part 15C			Test Distance:	3m		
Test item:	Radiated Emission			Power:	AC 120V/60Hz		
Model Number:	AC779S-200			Temp.(°C)/Hum.(%RH):	26(°C)/60%RH		
Mode:	3			Date:	12/04/2014		
Frequency:	2437MHz			Test By:	Eric Ou Yang		
Frequency (MHz)	Reading (dBuV)	Correct Factor (dB/m)	Result (dBuV/m)	Limit (dBuV/m)	Margin (dB)	Remark	Ant.Polar. H / V
3037.000	37.66	-0.44	37.22	74.00	-36.78	peak	H
4577.000	33.85	3.98	37.83	74.00	-36.17	peak	H
6705.000	33.09	9.54	42.63	74.00	-31.37	peak	H
3058.000	37.66	-0.38	37.28	74.00	-36.72	peak	V
4626.000	34.82	4.10	38.92	74.00	-35.08	peak	V
6691.000	32.97	9.50	42.47	74.00	-31.53	peak	V

Standard:	FCC Part 15C			Test Distance:	3m		
Test item:	Radiated Emission			Power:	AC 120V/60Hz		
Model Number:	AC779S-200			Temp.(°C)/Hum.(%RH):	26(°C)/60%RH		
Mode:	3			Date:	12/04/2014		
Frequency:	2462MHz			Test By:	Eric Ou Yang		
Frequency (MHz)	Reading (dBuV)	Correct Factor (dB/m)	Result (dBuV/m)	Limit (dBuV/m)	Margin (dB)	Remark	Ant.Polar. H / V
3037.000	36.33	-0.44	35.89	74.00	-38.11	peak	H
4647.000	34.66	4.16	38.82	74.00	-35.18	peak	H
6705.000	33.92	9.54	43.46	74.00	-30.54	peak	H
3037.000	36.81	-0.44	36.37	74.00	-37.63	peak	V
4605.000	35.30	4.05	39.35	74.00	-34.65	peak	V
6670.000	34.21	9.45	43.66	74.00	-30.34	peak	V

Standard:	FCC Part 15C	Test Distance:	3m
Test item:	Radiated Emission	Power:	AC 120V/60Hz
Model Number:	AC779S-200	Temp.(°C)/Hum.(%RH):	26(°C)/60%RH
Mode:	4	Date:	12/04/2014
Frequency:	2412MHz	Test By:	Eric Ou Yang

Frequency (MHz)	Reading (dBuV)	Correct Factor (dB/m)	Result (dBuV/m)	Limit (dBuV/m)	Margin (dB)	Remark	Ant.Polar. H / V
3009.000	36.62	-0.51	36.11	74.00	-37.89	peak	H
4591.000	35.11	4.01	39.12	74.00	-34.88	peak	H
6670.000	34.00	9.45	43.45	74.00	-30.55	peak	H
3009.000	36.71	-0.51	36.20	74.00	-37.80	peak	V
4591.000	35.00	4.01	39.01	74.00	-34.99	peak	V
6705.000	33.47	9.54	43.01	74.00	-30.99	peak	V

Standard:	FCC Part 15C	Test Distance:	3m
Test item:	Radiated Emission	Power:	AC 120V/60Hz
Model Number:	AC779S-200	Temp.(°C)/Hum.(%RH):	26(°C)/60%RH
Mode:	4	Date:	12/04/2014
Frequency:	2437MHz	Test By:	Eric Ou Yang

Frequency (MHz)	Reading (dBuV)	Correct Factor (dB/m)	Result (dBuV/m)	Limit (dBuV/m)	Margin (dB)	Remark	Ant.Polar. H / V
3030.000	36.68	-0.45	36.23	74.00	-37.77	peak	H
4563.000	33.85	3.95	37.80	74.00	-36.20	peak	H
6691.000	34.31	9.50	43.81	74.00	-30.19	peak	H
3051.000	38.10	-0.40	37.70	74.00	-36.30	peak	V
4598.000	35.15	4.04	39.19	74.00	-34.81	peak	V
6705.000	34.96	9.54	44.50	74.00	-29.50	peak	V

Standard:	FCC Part 15C		Test Distance:	3m			
Test item:	Radiated Emission		Power:	AC 120V/60Hz			
Model Number:	AC779S-200		Temp.(°C)/Hum.(%RH):	26(°C)/60%RH			
Mode:	4		Date:	12/04/2014			
Frequency:	2462MHz		Test By:	Eric Ou Yang			
Frequency (MHz)	Reading (dBuV)	Correct Factor (dB/m)	Result (dBuV/m)	Limit (dBuV/m)	Margin (dB)	Remark	Ant.Polar. H / V
3037.000	38.78	-0.44	38.34	74.00	-35.66	peak	H
4591.000	35.14	4.01	39.15	74.00	-34.85	peak	H
6691.000	34.35	9.50	43.85	74.00	-30.15	peak	H
3030.000	36.91	-0.45	36.46	74.00	-37.54	peak	V
4570.000	33.57	3.97	37.54	74.00	-36.46	peak	V
6698.000	34.37	9.53	43.90	74.00	-30.10	peak	V

Standard:	FCC Part 15C		Test Distance:	3m			
Test item:	Radiated Emission		Power:	AC 120V/60Hz			
Model Number:	AC779S-200		Temp.(°C)/Hum.(%RH):	26(°C)/60%RH			
Mode:	5		Date:	12/04/2014			
Frequency:	2422MHz		Test By:	Eric Ou Yang			
Frequency (MHz)	Reading (dBuV)	Correct Factor (dB/m)	Result (dBuV/m)	Limit (dBuV/m)	Margin (dB)	Remark	Ant.Polar. H / V
3009.000	37.42	-0.51	36.91	74.00	-37.09	peak	H
4591.000	34.46	4.01	38.47	74.00	-35.53	peak	H
6691.000	33.47	9.50	42.97	74.00	-31.03	peak	H
3051.000	37.56	-0.40	37.16	74.00	-36.84	peak	V
4598.000	34.34	4.04	38.38	74.00	-35.62	peak	V
6705.000	33.39	9.54	42.93	74.00	-31.07	peak	V

Standard:	FCC Part 15C			Test Distance:	3m		
Test item:	Radiated Emission			Power:	AC 120V/60Hz		
Model Number:	AC779S-200			Temp.(°C)/Hum.(%RH):	26(°C)/60%RH		
Mode:	5			Date:	12/04/2014		
Frequency:	2437MHz			Test By:	Eric Ou Yang		
Frequency (MHz)	Reading (dBuV)	Correct Factor (dB/m)	Result (dBuV/m)	Limit (dBuV/m)	Margin (dB)	Remark	Ant.Polar. H / V
3023.000	36.88	-0.48	36.40	74.00	-37.60	peak	H
4591.000	33.73	4.01	37.74	74.00	-36.26	peak	H
6621.000	34.83	9.31	44.14	74.00	-29.86	peak	H
3037.000	37.54	-0.44	37.10	74.00	-36.90	peak	V
4591.000	34.39	4.01	38.40	74.00	-35.60	peak	V
6677.000	33.51	9.46	42.97	74.00	-31.03	peak	V

Standard:	FCC Part 15C			Test Distance:	3m		
Test item:	Radiated Emission			Power:	AC 120V/60Hz		
Model Number:	AC779S-200			Temp.(°C)/Hum.(%RH):	26(°C)/60%RH		
Mode:	5			Date:	12/04/2014		
Frequency:	2452MHz			Test By:	Eric Ou Yang		
Frequency (MHz)	Reading (dBuV)	Correct Factor (dB/m)	Result (dBuV/m)	Limit (dBuV/m)	Margin (dB)	Remark	Ant.Polar. H / V
3023.000	36.75	-0.48	36.27	74.00	-37.73	peak	H
4626.000	33.71	4.10	37.81	74.00	-36.19	peak	H
6698.000	33.88	9.53	43.41	74.00	-30.59	peak	H
3023.000	37.33	-0.48	36.85	74.00	-37.15	peak	V
4563.000	33.97	3.95	37.92	74.00	-36.08	peak	V
6663.000	33.35	9.43	42.78	74.00	-31.22	peak	V

6 Maximum Conducted Output Power Measurement

6.1. Limit

For systems using digital modulation in the 2400-2483.5MHz, the limit for peak output power is 30dBm.

6.2. Test Setup

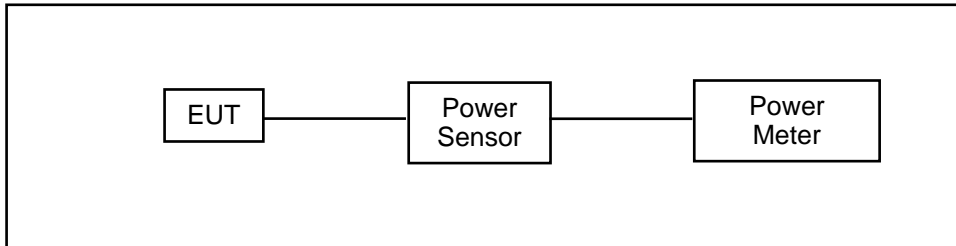

6.3. Test Instruments

Equipment	Manufacturer	Model Number	Serial Number	Cal. Date	Remark
Power Sensor	Anritsu	MA2411B	1126022	08/21/2014	(1)
Power Meter	Anritsu	ML2495A	1135009	08/21/2014	(1)
Test Site	ATL	TE05	TE05	N.C.R.	-----

Remark: (1) Calibration period 1 year. (2) Calibration period 2 years. (3) Calibration period 3 years.

Note: N.C.R. = No Calibration Request.

6.4. Test Procedure

The tests below are run with the EUT's transmitter set at high power in TX mode. The EUT is needed to force selection of output power level and channel number. While testing, EUT was set to transmit continuously. Remove the Subjective device's antenna and connect the RF output port to power sensor. The maximum peak output power shall not exceed 1 watt.

Use a direct connection between the antenna port of transmitter and the power sensor, for prevent the power sensor input attenuation 40-50 dB. Set the RBW Bandwidth of the emission or use a channel power meter mode.

For antennas with gains of 6 dBi or less, maximum allowed transmitter output is 1 watt (+30 dBm). For antennas with gains greater than 6 dBi, transmitter output level must be decreased by an amount equal to $(\text{GAIN} - 6)/3$ dBm.

The antenna port of the EUT was connected to the input of a power sensor. Power was read directly and cable loss correction was added to the reading to obtain power at the EUT antenna terminals.

6.5. Test Result

Model Number	AC779S-200					
Test Item	Maximum Conducted Output Power					
Test Mode	Mode 2: IEEE 802.11b Link Mode					
Date of Test	12/03/2014			Test Site	TE05	
Frequency (MHz)	Data Rate	Average Power		Peak Power		Limit (dBm)
		(dBm)	(W)	(dBm)	(W)	
2412	1M	9.85	0.010	12.52	0.018	< 30
2437		9.66	0.009	12.24	0.017	< 30
2462		9.64	0.009	12.20	0.017	< 30
2437	2M	9.61	0.009	12.19	0.017	< 30
2437	5.5M	9.60	0.009	12.16	0.016	< 30
2437	11M	9.57	0.009	12.11	0.016	< 30

Model Number	AC779S-200					
Test Item	Maximum Conducted Output Power					
Test Mode	Mode 3: IEEE 802.11g Link Mode					
Date of Test	12/03/2014			Test Site	TE05	
Frequency (MHz)	Data Rate	Average Power		Peak Power		Limit (dBm)
		(dBm)	(W)	(dBm)	(W)	
2412	6M	9.59	0.009	18.91	0.078	< 30
2437		9.40	0.009	18.73	0.075	< 30
2462		9.70	0.009	18.93	0.078	< 30
2437	9M	9.31	0.009	18.61	0.073	< 30
2437	12M	9.30	0.009	18.59	0.072	< 30
2437	18M	9.24	0.008	18.57	0.072	< 30
2437	24M	9.33	0.009	18.66	0.073	< 30
2437	36M	9.25	0.008	18.58	0.072	< 30
2437	48M	9.22	0.008	18.51	0.071	< 30
2437	54M	9.23	0.008	18.55	0.072	< 30

Model Number	AC779S-200					
Test Item	Maximum Conducted Output Power					
Test Mode	Mode 4: IEEE 802.11n 2.4GHz 20MHz Link Mode					
Date of Test	12/03/2014			Test Site	TE05	
Frequency (MHz)	Data Rate	Average Power		Peak Power		Limit (dBm)
		(dBm)	(W)	(dBm)	(W)	
2412	6M	9.89	0.010	19.51	0.089	< 30
2437		9.93	0.010	19.55	0.090	< 30
2462		9.75	0.009	18.89	0.077	< 30
2437	13M	9.85	0.010	19.48	0.089	< 30
2437	19.5M	9.78	0.010	19.41	0.087	< 30
2437	26M	9.79	0.010	19.42	0.087	< 30
2437	39M	9.82	0.010	19.45	0.088	< 30
2437	52M	9.75	0.009	19.36	0.086	< 30
2437	58.5M	9.71	0.009	19.34	0.086	< 30
2437	65M	9.75	0.009	19.38	0.087	< 30

Model Number	AC779S-200					
Test Item	Maximum Conducted Output Power					
Test Mode	Mode 5: IEEE 802.11n 2.4GHz 40MHz Link Mode					
Date of Test	12/03/2014			Test Site	TE05	
Frequency (MHz)	Data Rate	Average Power		Peak Power		Limit (dBm)
		(dBm)	(W)	(dBm)	(W)	
2422	13.5M	9.23	0.008	18.98	0.079	< 30
2437		9.38	0.009	19.07	0.081	< 30
2452		9.17	0.008	18.55	0.072	< 30
2437	27M	9.31	0.009	19.01	0.080	< 30
2437	40.5M	9.23	0.008	18.93	0.078	< 30
2437	54M	9.27	0.008	18.97	0.079	< 30
2437	81M	9.18	0.008	18.88	0.077	< 30
2437	108M	9.21	0.008	18.91	0.078	< 30
2437	121.5M	9.23	0.008	18.93	0.078	< 30
2437	135M	9.29	0.008	18.95	0.079	< 30

7 6dB RF Bandwidth Measurement

7.1. Limit

6dB RF Bandwidth: Systems using digital modulation techniques may operate in the 2400–2483.5 MHz bands. The minimum 6 dB band-width shall be at least 500 kHz.

7.2. Test Setup

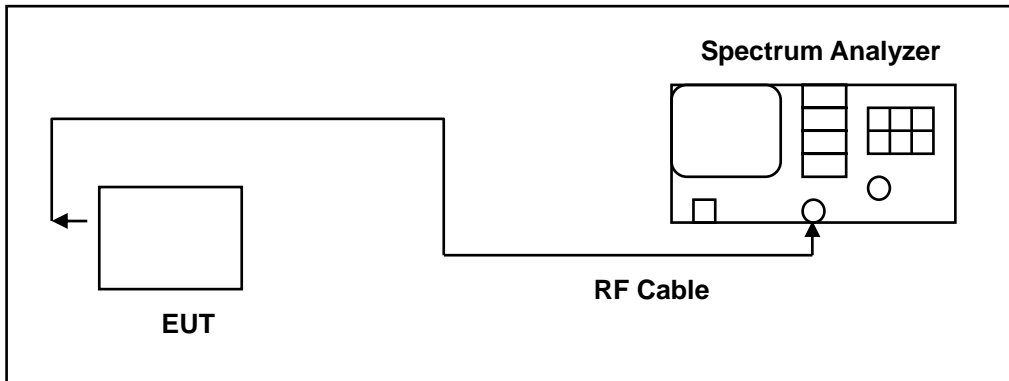

7.3. Test Instruments

Equipment	Manufacturer	Model Number	Serial Number	Cal. Date	Remark
Spectrum Analyzer	Agilent	E4445A	MY45300744	12/18/2013	(1)
Test Site	ATL	TE05	TE05	N.C.R.	-----

dRemark: (1) Calibration period 1 year. (2) Calibration period 2 years. (3) Calibration period 3 years.

Note: N.C.R. = No Calibration Request.

7.4. Test Procedure

The EUT was setup to ANSI C63.4:2014; tested to DTS test procedure of KDB558074D01 for compliance to FCC 47CFR 15.247 requirements.

6dB RF Bandwidth: The antenna port of the EUT was connected to the input of a spectrum analyzer. Analyzer RES BW was set to 100 kHz. For each RF output channel investigated, the spectrum analyzer center frequency was set to the channel carrier. A peak output reading was taken, a DISPLAY line was drawn 6 dB lower than peak level. The 6 dB bandwidth was determined from where the channel output spectrum intersected the display line.

The test was performed at 3 channels (Channel low, middle, high)

7.5. Test Result

Model Number	AC779S-200		
Test Item	6dB RF Bandwidth		
Test Mode	Mode 2: IEEE 802.11b Link Mode		
Date of Test	12/03/2014	Test Site	TE05
Frequency (MHz)	6dB RF Bandwidth (MHz)	6dB RF Bandwidth Limit (MHz)	
2412	9.698	> 0.500	
2437	10.041	> 0.500	
2462	9.681	> 0.500	

Model Number	AC779S-200		
Test Item	6dB RF Bandwidth		
Test Mode	Mode 3: IEEE 802.11g Link Mode		
Date of Test	12/03/2014	Test Site	TE05
Frequency (MHz)	6dB RF Bandwidth (MHz)	6dB RF Bandwidth Limit (MHz)	
2412	15.984	> 0.500	
2437	16.395	> 0.500	
2462	16.138	> 0.500	

Model Number	AC779S-200		
Test Item	6dB RF Bandwidth		
Test Mode	Mode 4: IEEE 802.11n 2.4GHz 20MHz Link Mode		
Date of Test	12/03/2014	Test Site	TE05
Frequency (MHz)	6dB RF Bandwidth (MHz)	6dB RF Bandwidth Limit (MHz)	
2412	16.679	> 0.500	
2437	17.330	> 0.500	
2462	17.336	> 0.500	

Model Number	AC779S-200		
Test Item	6dB RF Bandwidth		
Test Mode	Mode 5: IEEE 802.11n 2.4GHz 40MHz Link Mode		
Date of Test	12/03/2014	Test Site	TE05
Frequency (MHz)	6dB RF Bandwidth (MHz)	6dB RF Bandwidth Limit (MHz)	
2422	35.483	> 0.500	
2437	36.333	> 0.500	
2452	35.782	> 0.500	

7.6. Test Graphs

Mode 2: IEEE 802.11b Link Mode	
2412	<p>Agilent R T</p> <p>Ch Freq 2.412 GHz Trig Free</p> <p>Occupied Bandwidth</p> <p>Ref 10 dBm #Atten 20 dB</p> <p>#Peak Log 10 dB/Offset 11 dB</p> <p>Center 2.412 GHz Span 30 MHz #Res BW 100 kHz #VBW 300 kHz Sweep 4 ms (401 pts)</p> <p>Occupied Bandwidth 13.6672 MHz</p> <p>Occ BW % Pwr 99.00 % x dB -6.00 dB</p> <p>Transmit Freq Error 196.019 kHz x dB Bandwidth 9.698 MHz</p> <p>Freq/Channel</p> <p>Center Freq 2.41200000 GHz</p> <p>Start Freq 2.39700000 GHz</p> <p>Stop Freq 2.42700000 GHz</p> <p>CF Step 3.00000000 MHz Auto Man</p> <p>Freq Offset 0.00000000 Hz</p> <p>Signal Track On Off</p>
2437	<p>Agilent R T</p> <p>Ch Freq 2.437 GHz Trig Free</p> <p>Occupied Bandwidth</p> <p>Ref 10 dBm #Atten 20 dB</p> <p>#Peak Log 10 dB/Offset 11 dB</p> <p>Center 2.437 GHz Span 30 MHz #Res BW 100 kHz #VBW 300 kHz Sweep 4 ms (401 pts)</p> <p>Occupied Bandwidth 13.8746 MHz</p> <p>Occ BW % Pwr 99.00 % x dB -6.00 dB</p> <p>Transmit Freq Error -27.824 kHz x dB Bandwidth 10.041 MHz</p> <p>Freq/Channel</p> <p>Center Freq 2.43700000 GHz</p> <p>Start Freq 2.42200000 GHz</p> <p>Stop Freq 2.45200000 GHz</p> <p>CF Step 3.00000000 MHz Auto Man</p> <p>Freq Offset 0.00000000 Hz</p> <p>Signal Track On Off</p>
2462	<p>Agilent R T</p> <p>Ch Freq 2.462 GHz Trig Free</p> <p>Occupied Bandwidth</p> <p>Ref 10 dBm #Atten 20 dB</p> <p>#Peak Log 10 dB/Offset 11 dB</p> <p>Center 2.462 GHz Span 30 MHz #Res BW 100 kHz #VBW 300 kHz Sweep 4 ms (401 pts)</p> <p>Occupied Bandwidth 13.5724 MHz</p> <p>Occ BW % Pwr 99.00 % x dB -6.00 dB</p> <p>Transmit Freq Error 59.430 kHz x dB Bandwidth 9.681 MHz</p> <p>Freq/Channel</p> <p>Center Freq 2.46200000 GHz</p> <p>Start Freq 2.44700000 GHz</p> <p>Stop Freq 2.47700000 GHz</p> <p>CF Step 3.00000000 MHz Auto Man</p> <p>Freq Offset 0.00000000 Hz</p> <p>Signal Track On Off</p>

Mode 3: IEEE 802.11g Link Mode

<p>2412</p>	<p>Agilent R T</p> <p>Ch Freq 2.412 GHz Trig Free</p> <p>Occupied Bandwidth</p> <p>Ref 10 dBm #Atten 20 dB</p> <p>#Peak Log 10 dB/Offset 11 dB</p> <p>Center 2.412 GHz Span 30 MHz #Res BW 100 kHz #VBW 300 kHz Sweep 4 ms (401 pts)</p> <p>Occupied Bandwidth 16.3866 MHz</p> <p>Occ BW % Pwr 99.00 % x dB -6.00 dB</p> <p>Transmit Freq Error 56.425 kHz x dB Bandwidth 15.984 MHz</p> <p>Freq/Channel</p> <p>Center Freq 2.41200000 GHz</p> <p>Start Freq 2.39700000 GHz</p> <p>Stop Freq 2.42700000 GHz</p> <p>CF Step 3.00000000 MHz Auto Man</p> <p>Freq Offset 0.00000000 Hz</p> <p>Signal Track On Off</p>
<p>2437</p>	<p>Agilent R T</p> <p>Ch Freq 2.437 GHz Trig Free</p> <p>Occupied Bandwidth</p> <p>Ref 10 dBm #Atten 20 dB</p> <p>#Peak Log 10 dB/Offset 11 dB</p> <p>Center 2.437 GHz Span 30 MHz #Res BW 100 kHz #VBW 300 kHz Sweep 4 ms (401 pts)</p> <p>Occupied Bandwidth 16.4353 MHz</p> <p>Occ BW % Pwr 99.00 % x dB -6.00 dB</p> <p>Transmit Freq Error -14.503 kHz x dB Bandwidth 16.395 MHz</p> <p>Freq/Channel</p> <p>Center Freq 2.43700000 GHz</p> <p>Start Freq 2.42200000 GHz</p> <p>Stop Freq 2.45200000 GHz</p> <p>CF Step 3.00000000 MHz Auto Man</p> <p>Freq Offset 0.00000000 Hz</p> <p>Signal Track On Off</p>
<p>2462</p>	<p>Agilent R T</p> <p>Ch Freq 2.462 GHz Trig Free</p> <p>Occupied Bandwidth</p> <p>Ref 10 dBm #Atten 20 dB</p> <p>#Peak Log 10 dB/Offset 11 dB</p> <p>Center 2.462 GHz Span 30 MHz #Res BW 100 kHz #VBW 300 kHz Sweep 4 ms (401 pts)</p> <p>Occupied Bandwidth 16.3485 MHz</p> <p>Occ BW % Pwr 99.00 % x dB -6.00 dB</p> <p>Transmit Freq Error 14.314 kHz x dB Bandwidth 16.138 MHz</p> <p>Freq/Channel</p> <p>Center Freq 2.46200000 GHz</p> <p>Start Freq 2.44700000 GHz</p> <p>Stop Freq 2.47700000 GHz</p> <p>CF Step 3.00000000 MHz Auto Man</p> <p>Freq Offset 0.00000000 Hz</p> <p>Signal Track On Off</p>

Mode 4: IEEE 802.11n 2.4GHz 20MHz Link Mode

<p>2412</p>	<p>Agilent R T</p> <p>Ch Freq 2.412 GHz Trig Free</p> <p>Occupied Bandwidth</p> <p>Ref 10 dBm #Peak #Atten 20 dB</p> <p>Log 10 dB/Offst 11 dB</p> <p>Center 2.412 GHz Span 30 MHz #Res BW 100 kHz #VBW 300 kHz Sweep 4 ms (401 pts)</p> <p>Occupied Bandwidth Occ BW % Pwr 99.00 % 17.5625 MHz x dB -6.00 dB</p> <p>Transmit Freq Error 62.518 kHz x dB Bandwidth 16.679 MHz</p> <p>Freq/Channel</p> <p>Center Freq 2.41200000 GHz</p> <p>Start Freq 2.39700000 GHz</p> <p>Stop Freq 2.42700000 GHz</p> <p>CF Step 3.00000000 MHz Auto Man</p> <p>Freq Offset 0.00000000 Hz</p> <p>Signal Track On Off</p>
<p>2437</p>	<p>Agilent R T</p> <p>Ch Freq 2.437 GHz Trig Free</p> <p>Occupied Bandwidth</p> <p>Ref 10 dBm #Peak #Atten 20 dB</p> <p>Log 10 dB/Offst 11 dB</p> <p>Center 2.437 GHz Span 30 MHz #Res BW 100 kHz #VBW 300 kHz Sweep 4 ms (401 pts)</p> <p>Occupied Bandwidth Occ BW % Pwr 99.00 % 17.6243 MHz x dB -6.00 dB</p> <p>Transmit Freq Error -12.722 kHz x dB Bandwidth 17.330 MHz</p> <p>Freq/Channel</p> <p>Center Freq 2.43700000 GHz</p> <p>Start Freq 2.42200000 GHz</p> <p>Stop Freq 2.45200000 GHz</p> <p>CF Step 3.00000000 MHz Auto Man</p> <p>Freq Offset 0.00000000 Hz</p> <p>Signal Track On Off</p>
<p>2462</p>	<p>Agilent R T</p> <p>Ch Freq 2.462 GHz Trig Free</p> <p>Occupied Bandwidth</p> <p>Ref 10 dBm #Peak #Atten 20 dB</p> <p>Log 10 dB/Offst 11 dB</p> <p>Center 2.462 GHz Span 30 MHz #Res BW 100 kHz #VBW 300 kHz Sweep 4 ms (401 pts)</p> <p>Occupied Bandwidth Occ BW % Pwr 99.00 % 17.5419 MHz x dB -6.00 dB</p> <p>Transmit Freq Error 14.814 kHz x dB Bandwidth 17.336 MHz</p> <p>Freq/Channel</p> <p>Center Freq 2.46200000 GHz</p> <p>Start Freq 2.44700000 GHz</p> <p>Stop Freq 2.47700000 GHz</p> <p>CF Step 3.00000000 MHz Auto Man</p> <p>Freq Offset 0.00000000 Hz</p> <p>Signal Track On Off</p>

Mode 5: IEEE 802.11n 2.4GHz 40MHz Link Mode

<p>2422</p>	<p>Agilent R T</p> <p>Ch Freq 2.422 GHz Trig Free</p> <p>Occupied Bandwidth</p> <p>Ref 10 dBm #Atten 20 dB</p> <p>#Peak</p> <p>Log</p> <p>10 dB/Offset</p> <p>11 dB</p> <p>Center 2.422 GHz Span 50 MHz</p> <p>#Res BW 100 kHz #VBW 300 kHz Sweep 5.18 ms (401 pts)</p> <p>Occupied Bandwidth Occ BW % Pwr 99.00 %</p> <p>35.8736 MHz x dB -6.00 dB</p> <p>Transmit Freq Error 43.514 kHz</p> <p>x dB Bandwidth 35.483 MHz</p> <p>Freq/Channel</p> <p>Center Freq 2.42200000 GHz</p> <p>Start Freq 2.39700000 GHz</p> <p>Stop Freq 2.44700000 GHz</p> <p>CF Step 5.00000000 MHz Auto Man</p> <p>Freq Offset 0.00000000 Hz</p> <p>Signal Track On Off</p>
<p>2437</p>	<p>Agilent R T</p> <p>Ch Freq 2.437 GHz Trig Free</p> <p>Occupied Bandwidth</p> <p>Ref 10 dBm #Atten 20 dB</p> <p>#Peak</p> <p>Log</p> <p>10 dB/Offset</p> <p>11 dB</p> <p>Center 2.437 GHz Span 50 MHz</p> <p>#Res BW 100 kHz #VBW 300 kHz Sweep 5.18 ms (401 pts)</p> <p>Occupied Bandwidth Occ BW % Pwr 99.00 %</p> <p>36.1496 MHz x dB -6.00 dB</p> <p>Transmit Freq Error 1.140 kHz</p> <p>x dB Bandwidth 36.333 MHz</p> <p>Freq/Channel</p> <p>Center Freq 2.43700000 GHz</p> <p>Start Freq 2.41200000 GHz</p> <p>Stop Freq 2.46200000 GHz</p> <p>CF Step 5.00000000 MHz Auto Man</p> <p>Freq Offset 0.00000000 Hz</p> <p>Signal Track On Off</p>
<p>2452</p>	<p>Agilent R T</p> <p>Ch Freq 2.452 GHz Trig Free</p> <p>Occupied Bandwidth</p> <p>Ref 10 dBm #Atten 20 dB</p> <p>#Peak</p> <p>Log</p> <p>10 dB/Offset</p> <p>11 dB</p> <p>Center 2.452 GHz Span 50 MHz</p> <p>#Res BW 100 kHz #VBW 300 kHz Sweep 5.18 ms (401 pts)</p> <p>Occupied Bandwidth Occ BW % Pwr 99.00 %</p> <p>36.0157 MHz x dB -6.00 dB</p> <p>Transmit Freq Error 35.882 kHz</p> <p>x dB Bandwidth 35.782 MHz</p> <p>Freq/Channel</p> <p>Center Freq 2.45200000 GHz</p> <p>Start Freq 2.42700000 GHz</p> <p>Stop Freq 2.47700000 GHz</p> <p>CF Step 5.00000000 MHz Auto Man</p> <p>Freq Offset 0.00000000 Hz</p> <p>Signal Track On Off</p>

8 Maximum Power Density Measurement

8.1. Limit

For digitally modulated systems, the power spectral density conducted from the intentional radiator to the antenna shall not be greater than 8 dBm in any 3 kHz band during any time interval of continuous transmission.

8.2. Test Setup

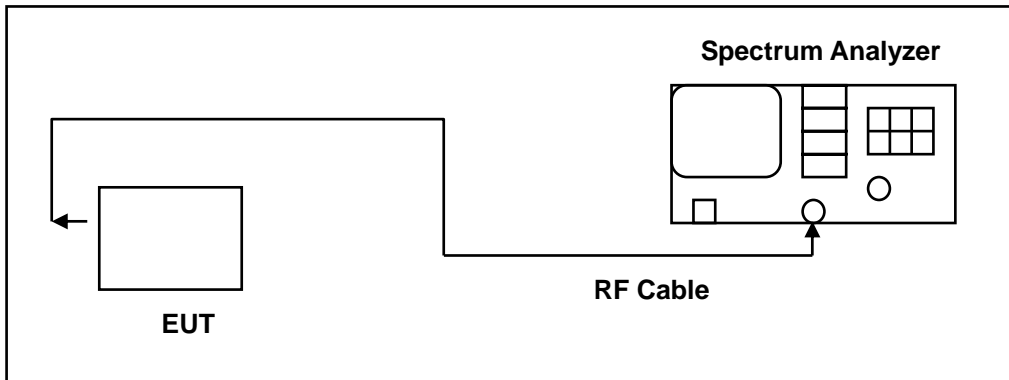

8.3. Test Instruments

Equipment	Manufacturer	Model Number	Serial Number	Cal. Date	Remark
Spectrum Analyzer	Agilent	E4445A	MY45300744	12/18/2013	(1)
Test Site	ATL	TE05	TE05	N.C.R.	-----

Remark: (1) Calibration period 1 year. (2) Calibration period 2 years. (3) Calibration period 3 years.

Note: N.C.R. = No Calibration Request.

8.4. Test Procedure

The EUT was setup to ANSI C63.4:2014; tested to DTS test procedure of KDB558074D01 for compliance to FCC 47CFR 15.247 requirements.

1. Set analyzer center frequency to DTS channel center frequency.
2. Set the span to 1.5 times the DTS bandwidth.
3. Set the RBW to: $3 \text{ kHz} \leq \text{RBW} \leq 100 \text{ kHz}$.
4. Set the VBW $\geq 3 \times \text{RBW}$.
5. Detector = peak.
6. Sweep time = auto couple.
7. Trace mode = max hold.
8. Allow trace to fully stabilize.
9. Use the peak marker function to determine the maximum amplitude level within the RBW.
10. If measured value exceeds limit, reduce RBW (no less than 3 kHz) and repeat.

8.5. Test Result

Model Number	AC779S-200		
Test Item	Maximum Power Density		
Test Mode	Mode 2: IEEE 802.11b Link Mode		
Date of Test	12/03/2014	Test Site	TE05
Frequency (MHz)	Reading (dBm/3KHz)		Limit (dBm)
2412	-15.30		< 8
2437	-15.82		< 8
2462	-15.55		< 8

Model Number	AC779S-200		
Test Item	Maximum Power Density		
Test Mode	Mode 3: IEEE 802.11g Link Mode		
Date of Test	12/03/2014	Test Site	TE05
Frequency (MHz)	Reading (dBm/3KHz)		Limit (dBm)
2412	-15.73		< 8
2437	-15.80		< 8
2462	-16.77		< 8

Model Number	AC779S-200		
Test Item	Maximum Power Density		
Test Mode	Mode 4: IEEE 802.11n 2.4GHz 20MHz Link Mode		
Date of Test	12/03/2014	Test Site	TE05
Frequency (MHz)	Reading (dBm/3KHz)		Limit (dBm)
2412	-14.97		< 8
2437	-15.71		< 8
2462	-16.11		< 8

Model Number	AC779S-200		
Test Item	Maximum Power Density		
Test Mode	Mode 5: IEEE 802.11n 2.4GHz 40MHz Link Mode		
Date of Test	12/03/2014	Test Site	TE05
Frequency (MHz)	Reading (dBm/3KHz)		Limit (dBm)
2422	-18.80		< 8
2437	-19.30		< 8
2452	-19.15		< 8

8.6. Test Graphs

Mode 2: IEEE 802.11b Link Mode	
2412	<p>Agilent R T Ref 10 dBm #Atten 20 dB Mkr1 2.41309 GHz -15.3 dBm Peak Log 10 dB/Offset 11 dB DI 8.0 dBm M1 S2 S3 FC AA Center 2.412 GHz Span 15.1 MHz #Res BW 3 kHz #VBW 10 kHz Sweep 1.727 s (401 pts)</p> <p>Freq/Channel Center Freq 2.41200000 GHz Start Freq 2.40445000 GHz Stop Freq 2.41955000 GHz CF Step 1.51000000 MHz Auto Man Freq Offset 0.00000000 Hz Signal Track On Off</p>
2437	<p>Agilent R T Ref 10 dBm #Atten 20 dB Mkr1 2.43409 GHz -15.82 dBm Peak Log 10 dB/Offset 11 dB DI 8.0 dBm M1 S2 S3 FC AA Center 2.437 GHz Span 15.1 MHz #Res BW 3 kHz #VBW 10 kHz Sweep 1.727 s (401 pts)</p> <p>Freq/Channel Center Freq 2.43700000 GHz Start Freq 2.42945000 GHz Stop Freq 2.44455000 GHz CF Step 1.51000000 MHz Auto Man Freq Offset 0.00000000 Hz Signal Track On Off</p>
2462	<p>Agilent R T Ref 10 dBm #Atten 20 dB Mkr1 2.46279 GHz -15.55 dBm Peak Log 10 dB/Offset 11 dB DI 8.0 dBm M1 S2 S3 FC AA Center 2.462 GHz Span 15.1 MHz #Res BW 3 kHz #VBW 10 kHz Sweep 1.727 s (401 pts)</p> <p>Freq/Channel Center Freq 2.46200000 GHz Start Freq 2.45445000 GHz Stop Freq 2.46955000 GHz CF Step 1.51000000 MHz Auto Man Freq Offset 0.00000000 Hz Signal Track On Off</p>

Mode 3: IEEE 802.11g Link Mode

2412	<p>Agilent R T</p> <p>Ref 10 dBm #Atten 20 dB Mkr1 2.4183175 GHz -15.73 dBm</p> <p>Peak Log 10 dB/Offset 11 dB DI 8.0 dBm</p> <p>M1 S2 S3 FC AA</p> <p>Center 2.412 GHz Span 26.6 MHz #Res BW 3 kHz #VBW 10 kHz Sweep 3.042 s (401 pts)</p> <p>Freq/Channel Center Freq 2.41200000 GHz Start Freq 2.39870000 GHz Stop Freq 2.42530000 GHz CF Step 2.66000000 MHz Auto Man Freq Offset 0.00000000 Hz Signal Track On Off</p>
2437	<p>Agilent R T</p> <p>Ref 10 dBm #Atten 20 dB Mkr1 2.4445145 GHz -15.8 dBm</p> <p>Peak Log 10 dB/Offset 11 dB DI 8.0 dBm</p> <p>M1 S2 S3 FC AA</p> <p>Center 2.437 GHz Span 26.6 MHz #Res BW 3 kHz #VBW 10 kHz Sweep 3.042 s (401 pts)</p> <p>Freq/Channel Center Freq 2.43700000 GHz Start Freq 2.42370000 GHz Stop Freq 2.45030000 GHz CF Step 2.66000000 MHz Auto Man Freq Offset 0.00000000 Hz Signal Track On Off</p>
2462	<p>Agilent R T</p> <p>Ref 10 dBm #Atten 20 dB Mkr1 2.4657905 GHz -16.77 dBm</p> <p>Peak Log 10 dB/Offset 11 dB DI 8.0 dBm</p> <p>M1 S2 S3 FC AA</p> <p>Center 2.462 GHz Span 26.6 MHz #Res BW 3 kHz #VBW 10 kHz Sweep 3.042 s (401 pts)</p> <p>Freq/Channel Center Freq 2.46200000 GHz Start Freq 2.44870000 GHz Stop Freq 2.47530000 GHz CF Step 2.66000000 MHz Auto Man Freq Offset 0.00000000 Hz Signal Track On Off</p>

Mode 4: IEEE 802.11n 2.4GHz 20MHz Link Mode

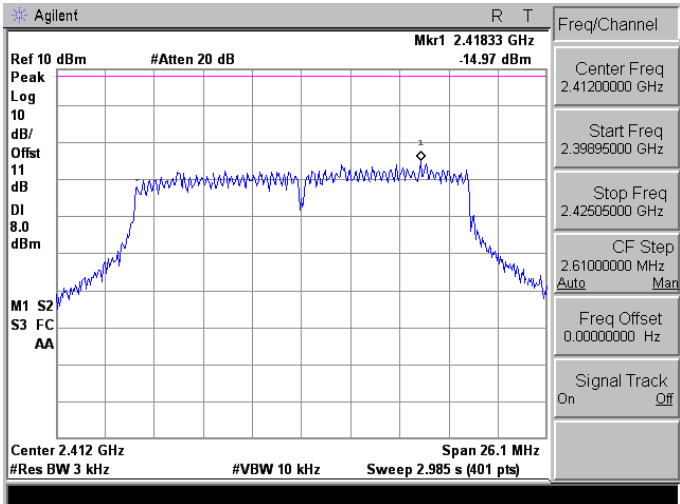
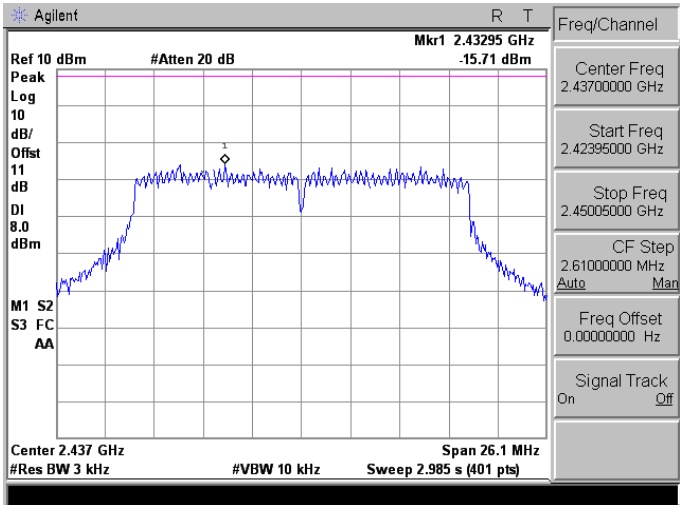
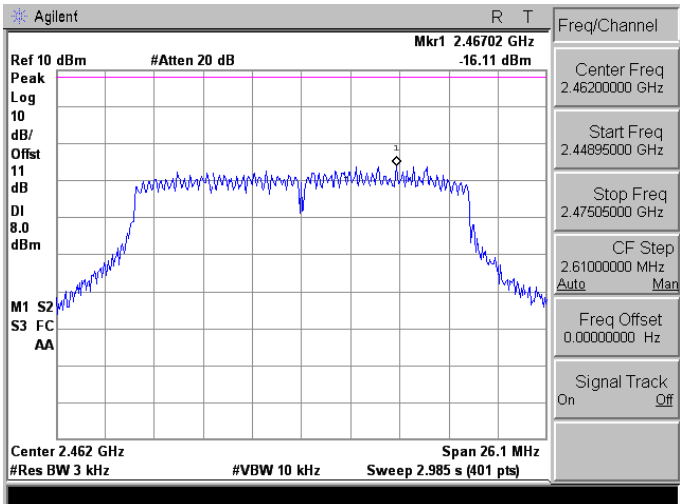
<p>2412</p>	
<p>2437</p>	
<p>2462</p>	

Mode 5: IEEE 802.11n 2.4GHz 40MHz Link Mode

<p>2422</p>	
<p>2437</p>	
<p>2452</p>	

9 Out of Band Conducted Emissions Measurement

9.1. Limit

In any 100 kHz bandwidth outside the frequency band in which the spread spectrum or digitally modulated intentional radiator is operating, the radio frequency power that is produced by the intentional radiator shall be at least 20 dB below that in the 100 kHz bandwidth within the band that contains the highest level of the desired power

9.2. Test Setup

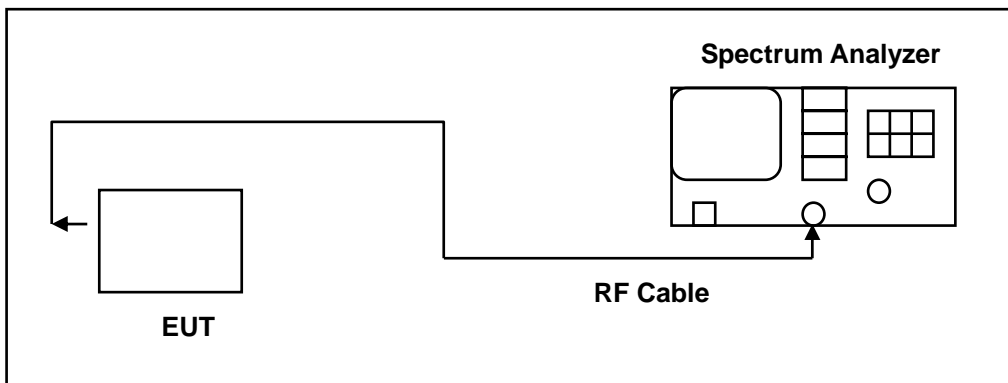

9.3. Test Instruments

Equipment	Manufacturer	Model Number	Serial Number	Cal. Date	Remark
Spectrum Analyzer	Agilent	E4445A	MY45300744	12/18/2013	(1)
Spectrum Analyzer	Agilent	E4408B	MY45107753	07/24/2014	(1)
Test Site	ATL	TE05	TE05	N.C.R.	-----

Remark: (1) Calibration period 1 year. (2) Calibration period 2 years. (3) Calibration period 3 years.

Note: N.C.R. = No Calibration Request.

9.4. Test Procedure

In any 100 kHz bandwidth outside the EUT pass band, the RF power produced by the modulation products of the spreading sequence, the information sequence, and the carrier frequency shall be at least 20 dB below that of the maximum in-band 100 kHz emission, antenna output of the EUT was coupled directly to spectrum analyzer; if an external attenuator and/or cable was used, these losses are compensated for with the analyzer OFFSET function.

All other types of emissions from the EUT shall meet the general limits for radiated frequencies outside the pass band.

The test was performed at 3 channels.

9.5. Test Graphs

Reference level

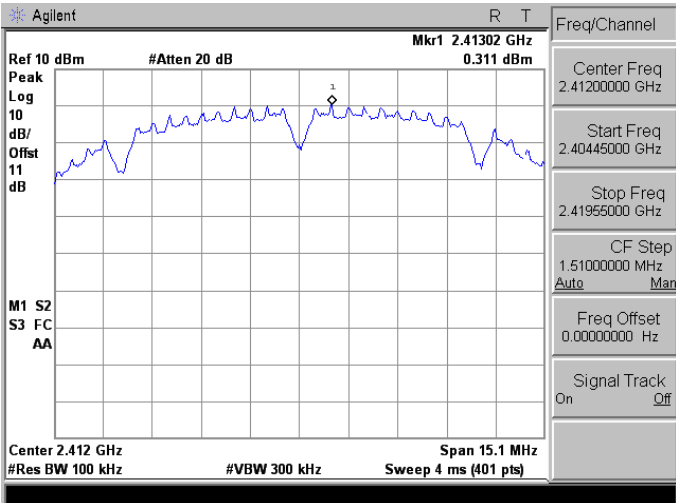
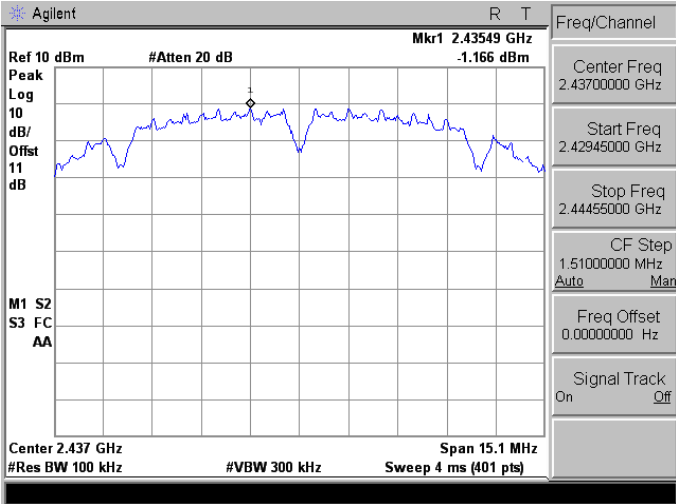
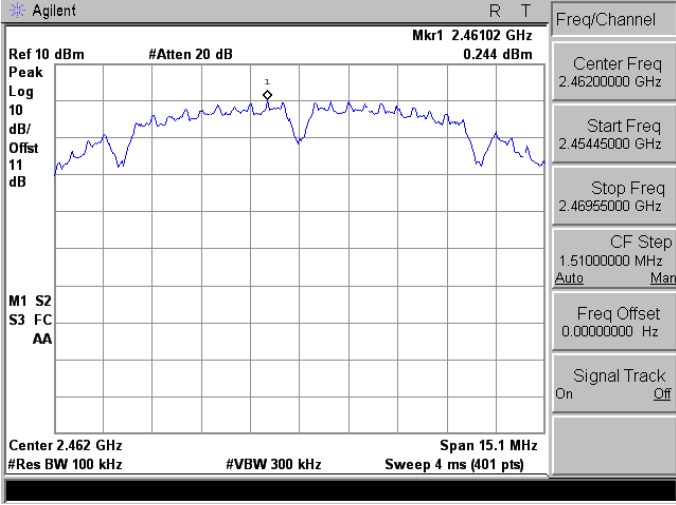
Mode 2: IEEE 802.11b Link Mode	
2412	 <p>Agilent R T Ref 10 dBm #Atten 20 dB Mkr1 2.41302 GHz 0.311 dBm Peak Log 10 dB/Offst 11 dB M1 S2 S3 FC AA Center 2.412 GHz #Res BW 100 kHz #VBW 300 kHz Span 15.1 MHz Sweep 4 ms (401 pts)</p> <p>Freq/Channel Center Freq 2.41200000 GHz Start Freq 2.40445000 GHz Stop Freq 2.41955000 GHz CF Step 1.51000000 MHz Auto Man Freq Offset 0.00000000 Hz Signal Track On Off</p>
2437	 <p>Agilent R T Ref 10 dBm #Atten 20 dB Mkr1 2.43549 GHz -1.166 dBm Peak Log 10 dB/Offst 11 dB M1 S2 S3 FC AA Center 2.437 GHz #Res BW 100 kHz #VBW 300 kHz Span 15.1 MHz Sweep 4 ms (401 pts)</p> <p>Freq/Channel Center Freq 2.43700000 GHz Start Freq 2.42945000 GHz Stop Freq 2.44455000 GHz CF Step 1.51000000 MHz Auto Man Freq Offset 0.00000000 Hz Signal Track On Off</p>
2462	 <p>Agilent R T Ref 10 dBm #Atten 20 dB Mkr1 2.46102 GHz 0.244 dBm Peak Log 10 dB/Offst 11 dB M1 S2 S3 FC AA Center 2.462 GHz #Res BW 100 kHz #VBW 300 kHz Span 15.1 MHz Sweep 4 ms (401 pts)</p> <p>Freq/Channel Center Freq 2.46200000 GHz Start Freq 2.45445000 GHz Stop Freq 2.46955000 GHz CF Step 1.51000000 MHz Auto Man Freq Offset 0.00000000 Hz Signal Track On Off</p>

Mode 3: IEEE 802.11g Link Mode

2412	
2437	
2462	

Mode 4: IEEE 802.11n 2.4GHz 20MHz Link Mode

<p>2412</p>	<p>Agilent R T</p> <p>Ref 10 dBm #Atten 20 dB Mkr1 2.41702 GHz Peak Log 10 dB/Offset 11 dB -0.236 dBm</p> <p>M1 S2 S3 FC AA</p> <p>Center 2.412 GHz Span 26.1 MHz #Res BW 100 kHz #VBW 300 kHz Sweep 4 ms (401 pts)</p> <p>Freq/Channel Center Freq 2.41200000 GHz Start Freq 2.39895000 GHz Stop Freq 2.42505000 GHz CF Step 2.61000000 MHz Auto Man Freq Offset 0.00000000 Hz Signal Track On Off</p>
<p>2437</p>	<p>Agilent R T</p> <p>Ref 10 dBm #Atten 20 dB Mkr1 2.43074 GHz Peak Log 10 dB/Offset 11 dB -0.754 dBm</p> <p>M1 S2 S3 FC AA</p> <p>Center 2.437 GHz Span 26.1 MHz #Res BW 100 kHz #VBW 300 kHz Sweep 4 ms (401 pts)</p> <p>Freq/Channel Center Freq 2.43700000 GHz Start Freq 2.42395000 GHz Stop Freq 2.45005000 GHz CF Step 2.61000000 MHz Auto Man Freq Offset 0.00000000 Hz Signal Track On Off</p>
<p>2462</p>	<p>Agilent R T</p> <p>Ref 10 dBm #Atten 20 dB Mkr1 2.46696 GHz Peak Log 10 dB/Offset 11 dB -1.434 dBm</p> <p>M1 S2 S3 FC AA</p> <p>Center 2.462 GHz Span 26.1 MHz #Res BW 100 kHz #VBW 300 kHz Sweep 4 ms (401 pts)</p> <p>Freq/Channel Center Freq 2.46200000 GHz Start Freq 2.44895000 GHz Stop Freq 2.47505000 GHz CF Step 2.61000000 MHz Auto Man Freq Offset 0.00000000 Hz Signal Track On Off</p>

Mode 5: IEEE 802.11n 2.4GHz 40MHz Link Mode

<p>2422</p>	<p>Agilent R T</p> <p>Ref 10 dBm #Atten 20 dB Mkr1 2.42582 GHz 4.589 dBm</p> <p>Peak Log 10 dB/Offst 11 dB</p> <p>M1 S2 S3 FC AA</p> <p>Center 2.422 GHz Span 54.5 MHz #Res BW 100 kHz #VBW 300 kHz Sweep 5.646 ms (401 pts)</p> <p>Freq/Channel</p> <p>Center Freq 2.4220000 GHz</p> <p>Start Freq 2.39475000 GHz</p> <p>Stop Freq 2.44925000 GHz</p> <p>CF Step 5.45000000 MHz Auto Man</p> <p>Freq Offset 0.00000000 Hz</p> <p>Signal Track On Off</p>
<p>2437</p>	<p>Agilent R T</p> <p>Ref 10 dBm #Atten 20 dB Mkr1 2.42201 GHz 3.957 dBm</p> <p>Peak Log 10 dB/Offst 11 dB</p> <p>M1 S2 S3 FC AA</p> <p>Center 2.437 GHz Span 54.5 MHz #Res BW 100 kHz #VBW 300 kHz Sweep 5.646 ms (401 pts)</p> <p>Freq/Channel</p> <p>Center Freq 2.4370000 GHz</p> <p>Start Freq 2.40975000 GHz</p> <p>Stop Freq 2.46425000 GHz</p> <p>CF Step 5.45000000 MHz Auto Man</p> <p>Freq Offset 0.00000000 Hz</p> <p>Signal Track On Off</p>
<p>2452</p>	<p>Agilent R T</p> <p>Ref 10 dBm #Atten 20 dB Mkr1 2.46576 GHz 3.864 dBm</p> <p>Peak Log 10 dB/Offst 11 dB</p> <p>M1 S2 S3 FC AA</p> <p>Center 2.452 GHz Span 54.5 MHz #Res BW 100 kHz #VBW 300 kHz Sweep 5.646 ms (401 pts)</p> <p>Freq/Channel</p> <p>Center Freq 2.4520000 GHz</p> <p>Start Freq 2.42475000 GHz</p> <p>Stop Freq 2.47925000 GHz</p> <p>CF Step 5.45000000 MHz Auto Man</p> <p>Freq Offset 0.00000000 Hz</p> <p>Signal Track On Off</p>

Out of Band Conducted Emissions

Mode 2: IEEE 802.11b Link Mode

<p>2412</p>	<p>Agilent R T</p> <p>Ref 10 dBm #Atten 20 dB Mkr1 2.41 GHz -0.343 dBm</p> <p>Peak Log 10 dB/Offst 11 dB DI -19.7 dBm</p> <p>Start 30 MHz #Res BW 100 kHz #VBW 300 kHz Stop 26.5 GHz Sweep 2.742 s (401 pts)</p> <table border="1"> <thead> <tr> <th>Marker</th> <th>Trace</th> <th>Type</th> <th>X Axis</th> <th>Amplitude</th> </tr> </thead> <tbody> <tr> <td>1</td> <td>(1)</td> <td>Freq</td> <td>2.41 GHz</td> <td>-0.343 dBm</td> </tr> </tbody> </table> <p>Freq/Channel: Center Freq 13.2650000 GHz, Start Freq 30.0000000 MHz, Stop Freq 26.5000000 GHz, CF Step 2.64700000 GHz Auto Man, Freq Offset 0.0000000 Hz, Signal Track On Off</p>	Marker	Trace	Type	X Axis	Amplitude	1	(1)	Freq	2.41 GHz	-0.343 dBm
Marker	Trace	Type	X Axis	Amplitude							
1	(1)	Freq	2.41 GHz	-0.343 dBm							
<p>2437</p>	<p>Agilent R T</p> <p>Ref 10 dBm #Atten 20 dB Mkr1 2.44 GHz -0.542 dBm</p> <p>Peak Log 10 dB/Offst 11 dB DI -21.2 dBm</p> <p>Start 30 MHz #Res BW 100 kHz #VBW 300 kHz Stop 26.5 GHz Sweep 2.742 s (401 pts)</p> <table border="1"> <thead> <tr> <th>Marker</th> <th>Trace</th> <th>Type</th> <th>X Axis</th> <th>Amplitude</th> </tr> </thead> <tbody> <tr> <td>1</td> <td>(1)</td> <td>Freq</td> <td>2.44 GHz</td> <td>-0.542 dBm</td> </tr> </tbody> </table> <p>Freq/Channel: Center Freq 13.2650000 GHz, Start Freq 30.0000000 MHz, Stop Freq 26.5000000 GHz, CF Step 2.64700000 GHz Auto Man, Freq Offset 0.0000000 Hz, Signal Track On Off</p>	Marker	Trace	Type	X Axis	Amplitude	1	(1)	Freq	2.44 GHz	-0.542 dBm
Marker	Trace	Type	X Axis	Amplitude							
1	(1)	Freq	2.44 GHz	-0.542 dBm							
<p>2462</p>	<p>Agilent R T</p> <p>Ref 10 dBm #Atten 20 dB Mkr1 2.46 GHz -0.156 dBm</p> <p>Peak Log 10 dB/Offst 11 dB DI -19.8 dBm</p> <p>Start 30 MHz #Res BW 100 kHz #VBW 300 kHz Stop 26.5 GHz Sweep 2.742 s (401 pts)</p> <table border="1"> <thead> <tr> <th>Marker</th> <th>Trace</th> <th>Type</th> <th>X Axis</th> <th>Amplitude</th> </tr> </thead> <tbody> <tr> <td>1</td> <td>(1)</td> <td>Freq</td> <td>2.46 GHz</td> <td>-0.156 dBm</td> </tr> </tbody> </table> <p>Freq/Channel: Center Freq 13.2650000 GHz, Start Freq 30.0000000 MHz, Stop Freq 26.5000000 GHz, CF Step 2.64700000 GHz Auto Man, Freq Offset 0.0000000 Hz, Signal Track On Off</p>	Marker	Trace	Type	X Axis	Amplitude	1	(1)	Freq	2.46 GHz	-0.156 dBm
Marker	Trace	Type	X Axis	Amplitude							
1	(1)	Freq	2.46 GHz	-0.156 dBm							

Mode 3: IEEE 802.11g Link Mode

2412	<p>Agilent R T</p> <p>Ref 10 dBm #Atten 20 dB Mkr1 2.41 GHz -3.946 dBm</p> <p>Peak Log 10 dB/Offset 11 dB DI -20.2 dBm</p> <p>Start 30 MHz Stop 26.5 GHz</p> <p>#Res BW 100 kHz #VBW 300 kHz Sweep 2.742 s (401 pts)</p> <table border="1"> <thead> <tr> <th>Marker</th> <th>Trace</th> <th>Type</th> <th>X Axis</th> <th>Amplitude</th> </tr> </thead> <tbody> <tr> <td>1</td> <td>(1)</td> <td>Freq</td> <td>2.41 GHz</td> <td>-3.946 dBm</td> </tr> </tbody> </table> <p>Freq/Channel</p> <p>Center Freq 13.2650000 GHz</p> <p>Start Freq 30.0000000 MHz</p> <p>Stop Freq 26.5000000 GHz</p> <p>CF Step 2.64700000 GHz Auto Man</p> <p>Freq Offset 0.00000000 Hz</p> <p>Signal Track On Off</p>	Marker	Trace	Type	X Axis	Amplitude	1	(1)	Freq	2.41 GHz	-3.946 dBm
Marker	Trace	Type	X Axis	Amplitude							
1	(1)	Freq	2.41 GHz	-3.946 dBm							
2437	<p>Agilent R T</p> <p>Ref 10 dBm #Atten 20 dB Mkr1 2.44 GHz -4.261 dBm</p> <p>Peak Log 10 dB/Offset 11 dB DI -20.9 dBm</p> <p>Start 30 MHz Stop 26.5 GHz</p> <p>#Res BW 100 kHz #VBW 300 kHz Sweep 2.742 s (401 pts)</p> <table border="1"> <thead> <tr> <th>Marker</th> <th>Trace</th> <th>Type</th> <th>X Axis</th> <th>Amplitude</th> </tr> </thead> <tbody> <tr> <td>1</td> <td>(1)</td> <td>Freq</td> <td>2.44 GHz</td> <td>-4.261 dBm</td> </tr> </tbody> </table> <p>Freq/Channel</p> <p>Center Freq 13.2650000 GHz</p> <p>Start Freq 30.0000000 MHz</p> <p>Stop Freq 26.5000000 GHz</p> <p>CF Step 2.64700000 GHz Auto Man</p> <p>Freq Offset 0.00000000 Hz</p> <p>Signal Track On Off</p>	Marker	Trace	Type	X Axis	Amplitude	1	(1)	Freq	2.44 GHz	-4.261 dBm
Marker	Trace	Type	X Axis	Amplitude							
1	(1)	Freq	2.44 GHz	-4.261 dBm							
2462	<p>Agilent R T</p> <p>Ref 10 dBm #Atten 20 dB Mkr1 2.46 GHz -3.703 dBm</p> <p>Peak Log 10 dB/Offset 11 dB DI -20.4 dBm</p> <p>Start 30 MHz Stop 26.5 GHz</p> <p>#Res BW 100 kHz #VBW 300 kHz Sweep 2.742 s (401 pts)</p> <table border="1"> <thead> <tr> <th>Marker</th> <th>Trace</th> <th>Type</th> <th>X Axis</th> <th>Amplitude</th> </tr> </thead> <tbody> <tr> <td>1</td> <td>(1)</td> <td>Freq</td> <td>2.46 GHz</td> <td>-3.703 dBm</td> </tr> </tbody> </table> <p>Freq/Channel</p> <p>Center Freq 13.2650000 GHz</p> <p>Start Freq 30.0000000 MHz</p> <p>Stop Freq 26.5000000 GHz</p> <p>CF Step 2.64700000 GHz Auto Man</p> <p>Freq Offset 0.00000000 Hz</p> <p>Signal Track On Off</p>	Marker	Trace	Type	X Axis	Amplitude	1	(1)	Freq	2.46 GHz	-3.703 dBm
Marker	Trace	Type	X Axis	Amplitude							
1	(1)	Freq	2.46 GHz	-3.703 dBm							

Mode 4: IEEE 802.11n 2.4GHz 20MHz Link Mode

2412	<p>Agilent R T Ref 10 dBm #Atten 20 dB Mkr1 2.41 GHz -2.156 dBm Peak Log 10 dB/Offset 11 dB DI -20.2 dBm Start 30 MHz Stop 26.5 GHz #Res BW 100 kHz #VBW 300 kHz Sweep 2.742 s (401 pts) Marker Trace Type X Axis Amplitude 1 (1) Freq 2.41 GHz -2.156 dBm</p> <p>Freq/Channel Center Freq 13.2650000 GHz Start Freq 30.0000000 MHz Stop Freq 26.5000000 GHz CF Step 2.64700000 GHz Auto Man Freq Offset 0.00000000 Hz Signal Track On Off</p>
2437	<p>Agilent R T Ref 10 dBm #Atten 20 dB Mkr1 2.44 GHz -1.329 dBm Peak Log 10 dB/Offset 11 dB DI -20.8 dBm Start 30 MHz Stop 26.5 GHz #Res BW 100 kHz #VBW 300 kHz Sweep 2.742 s (401 pts) Marker Trace Type X Axis Amplitude 1 (1) Freq 2.44 GHz -1.329 dBm</p> <p>Freq/Channel Center Freq 13.2650000 GHz Start Freq 30.0000000 MHz Stop Freq 26.5000000 GHz CF Step 2.64700000 GHz Auto Man Freq Offset 0.00000000 Hz Signal Track On Off</p>
2462	<p>Agilent R T Ref 10 dBm #Atten 20 dB Mkr1 2.46 GHz -3.716 dBm Peak Log 10 dB/Offset 11 dB DI -21.4 dBm Start 30 MHz Stop 26.5 GHz #Res BW 100 kHz #VBW 300 kHz Sweep 2.742 s (401 pts) Marker Trace Type X Axis Amplitude 1 (1) Freq 2.46 GHz -3.716 dBm</p> <p>Freq/Channel Center Freq 13.2650000 GHz Start Freq 30.0000000 MHz Stop Freq 26.5000000 GHz CF Step 2.64700000 GHz Auto Man Freq Offset 0.00000000 Hz Signal Track On Off</p>

Mode 5: IEEE 802.11n 2.4GHz 40MHz Link Mode

2422	<p>Agilent R T</p> <p>Ref 10 dBm #Atten 20 dB Mkr1 2.42 GHz 5.118 dBm</p> <p>Peak Log 10 dB/Offset 11 dB DI -24.6 dBm</p> <p>Start 30 MHz Stop 26.5 GHz</p> <p>#Res BW 100 kHz #VBW 300 kHz Sweep 2.742 s (401 pts)</p> <table border="1"> <thead> <tr> <th>Marker</th> <th>Trace</th> <th>Type</th> <th>X Axis</th> <th>Amplitude</th> </tr> </thead> <tbody> <tr> <td>1</td> <td>(1)</td> <td>Freq</td> <td>2.42 GHz</td> <td>-5.118 dBm</td> </tr> </tbody> </table> <p>Freq/Channel</p> <p>Center Freq 13.2650000 GHz</p> <p>Start Freq 30.0000000 MHz</p> <p>Stop Freq 26.5000000 GHz</p> <p>CF Step 2.64700000 GHz Auto Man</p> <p>Freq Offset 0.00000000 Hz</p> <p>Signal Track On Off</p>	Marker	Trace	Type	X Axis	Amplitude	1	(1)	Freq	2.42 GHz	-5.118 dBm
Marker	Trace	Type	X Axis	Amplitude							
1	(1)	Freq	2.42 GHz	-5.118 dBm							
2437	<p>Agilent R T</p> <p>Ref 10 dBm #Atten 20 dB Mkr1 2.44 GHz 4.207 dBm</p> <p>Peak Log 10 dB/Offset 11 dB DI -24.0 dBm</p> <p>Start 30 MHz Stop 26.5 GHz</p> <p>#Res BW 100 kHz #VBW 300 kHz Sweep 2.742 s (401 pts)</p> <table border="1"> <thead> <tr> <th>Marker</th> <th>Trace</th> <th>Type</th> <th>X Axis</th> <th>Amplitude</th> </tr> </thead> <tbody> <tr> <td>1</td> <td>(1)</td> <td>Freq</td> <td>2.44 GHz</td> <td>-4.207 dBm</td> </tr> </tbody> </table> <p>Freq/Channel</p> <p>Center Freq 13.2650000 GHz</p> <p>Start Freq 30.0000000 MHz</p> <p>Stop Freq 26.5000000 GHz</p> <p>CF Step 2.64700000 GHz Auto Man</p> <p>Freq Offset 0.00000000 Hz</p> <p>Signal Track On Off</p>	Marker	Trace	Type	X Axis	Amplitude	1	(1)	Freq	2.44 GHz	-4.207 dBm
Marker	Trace	Type	X Axis	Amplitude							
1	(1)	Freq	2.44 GHz	-4.207 dBm							
2452	<p>Agilent R T</p> <p>Ref 10 dBm #Atten 20 dB Mkr1 2.45 GHz 5.616 dBm</p> <p>Peak Log 10 dB/Offset 11 dB DI -23.9 dBm</p> <p>Start 30 MHz Stop 26.5 GHz</p> <p>#Res BW 100 kHz #VBW 300 kHz Sweep 2.742 s (401 pts)</p> <table border="1"> <thead> <tr> <th>Marker</th> <th>Trace</th> <th>Type</th> <th>X Axis</th> <th>Amplitude</th> </tr> </thead> <tbody> <tr> <td>1</td> <td>(1)</td> <td>Freq</td> <td>2.45 GHz</td> <td>-5.616 dBm</td> </tr> </tbody> </table> <p>Freq/Channel</p> <p>Center Freq 13.2650000 GHz</p> <p>Start Freq 30.0000000 MHz</p> <p>Stop Freq 26.5000000 GHz</p> <p>CF Step 2.64700000 GHz Auto Man</p> <p>Freq Offset 0.00000000 Hz</p> <p>Signal Track On Off</p>	Marker	Trace	Type	X Axis	Amplitude	1	(1)	Freq	2.45 GHz	-5.616 dBm
Marker	Trace	Type	X Axis	Amplitude							
1	(1)	Freq	2.45 GHz	-5.616 dBm							

Conducted Band Edge

Mode 2: IEEE 802.11b Link Mode

2412

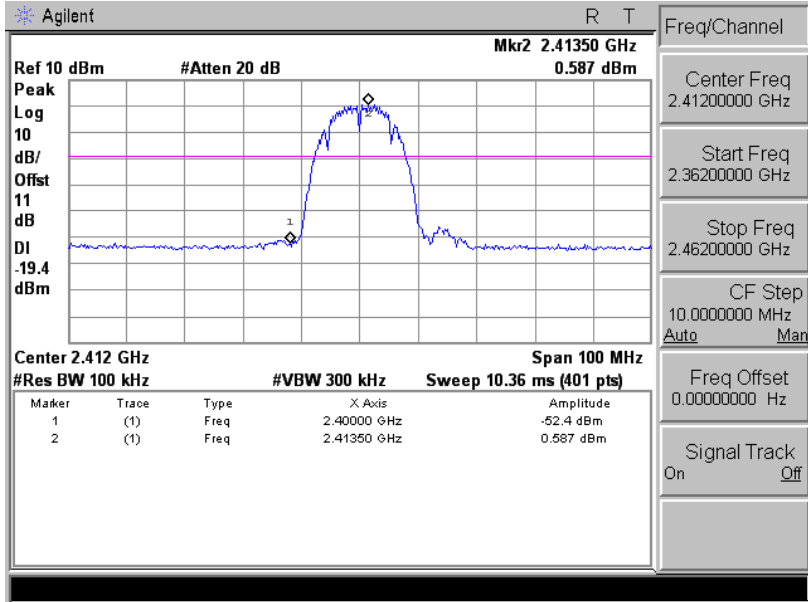

2462

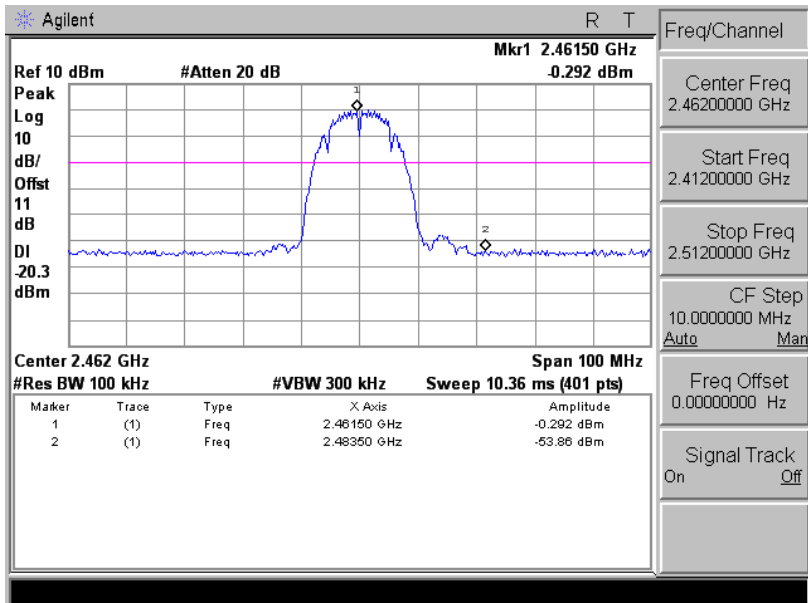

Mode 3: IEEE 802.11g Link Mode

2412

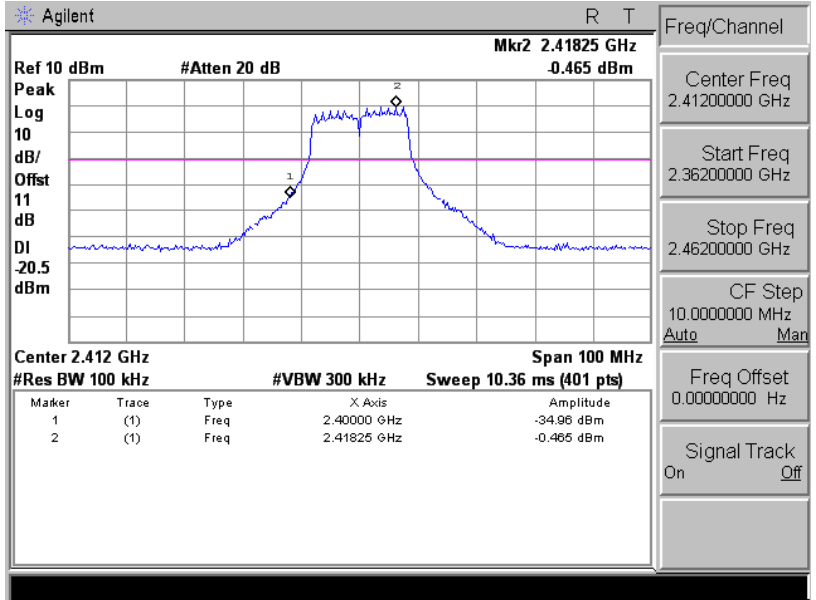

2462

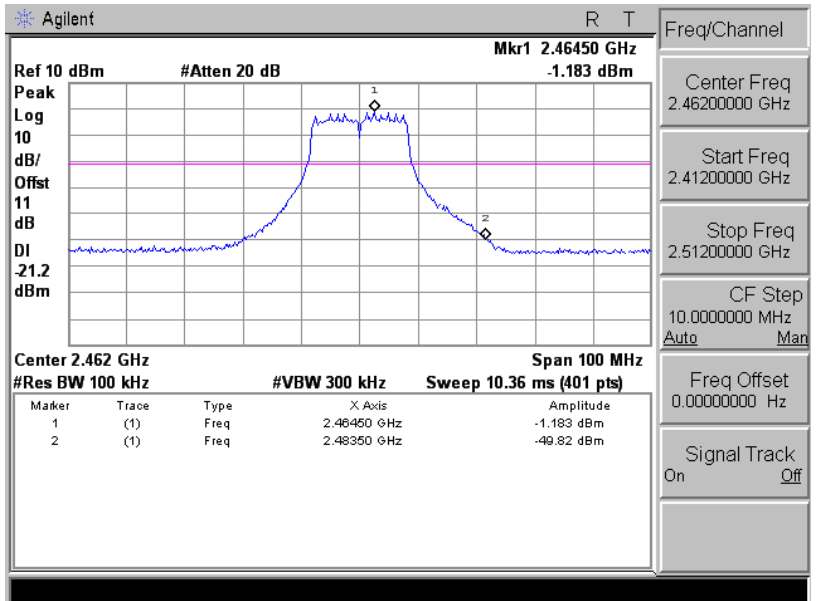

Mode 4: IEEE 802.11n 2.4GHz 20MHz Link Mode

2412

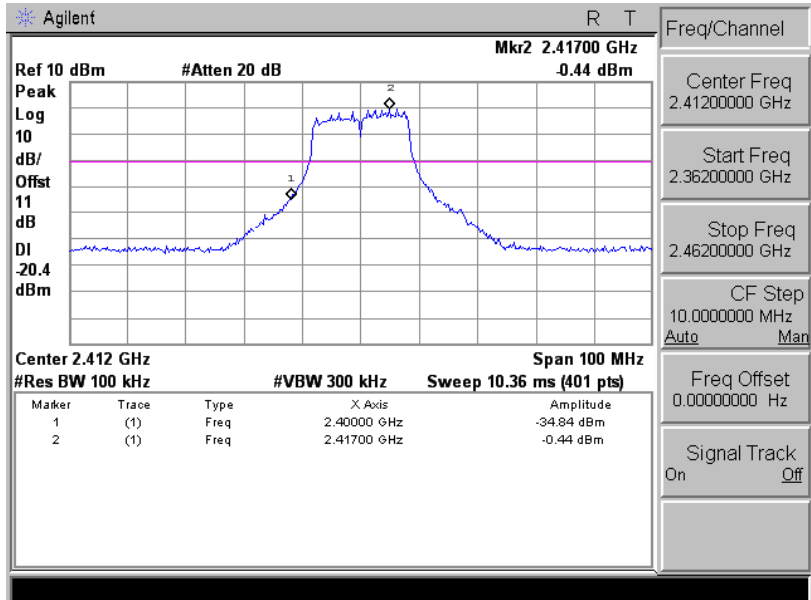

2462

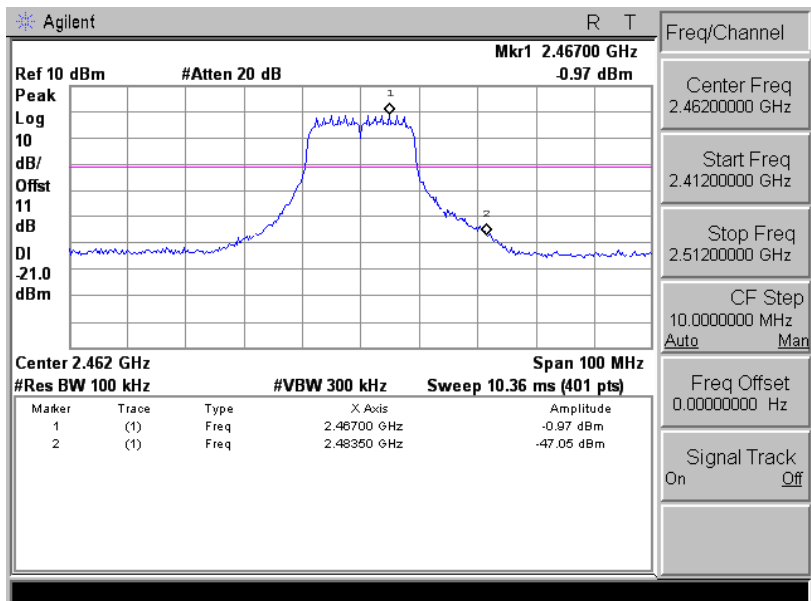

Mode 5: IEEE 802.11n 2.4GHz 40MHz Link Mode

2422

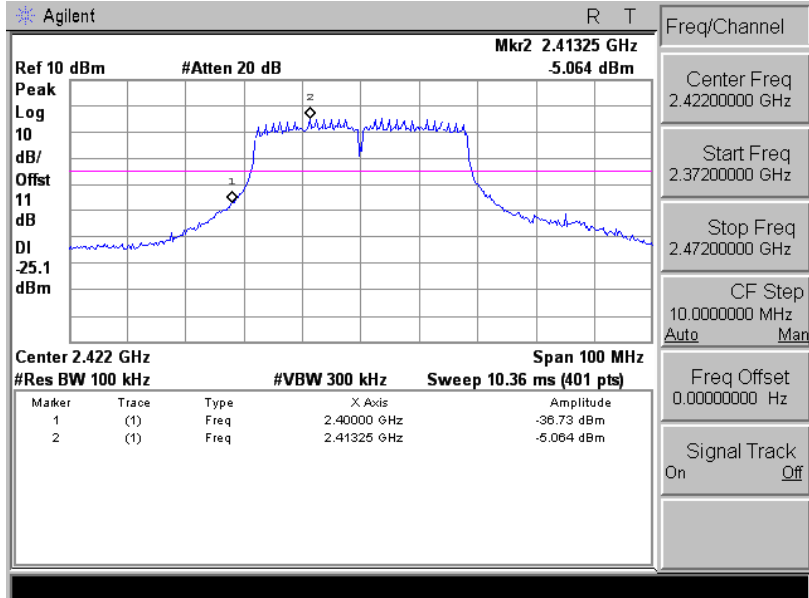

2452

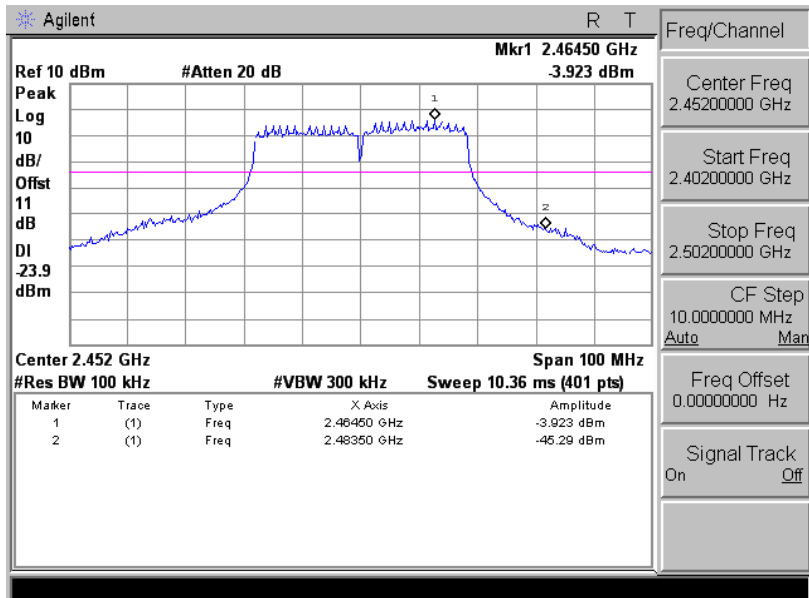

10 Band Edges Measurement

10.1.Limit

In any 100 kHz bandwidth outside the intentional radiation frequency band, the radio frequency power shall be at least 20 dB below the highest level of the radiated power. In addition, radiated emissions which fall in the restricted bands must also comply with the radiated emission limits.

10.2.Test Setup

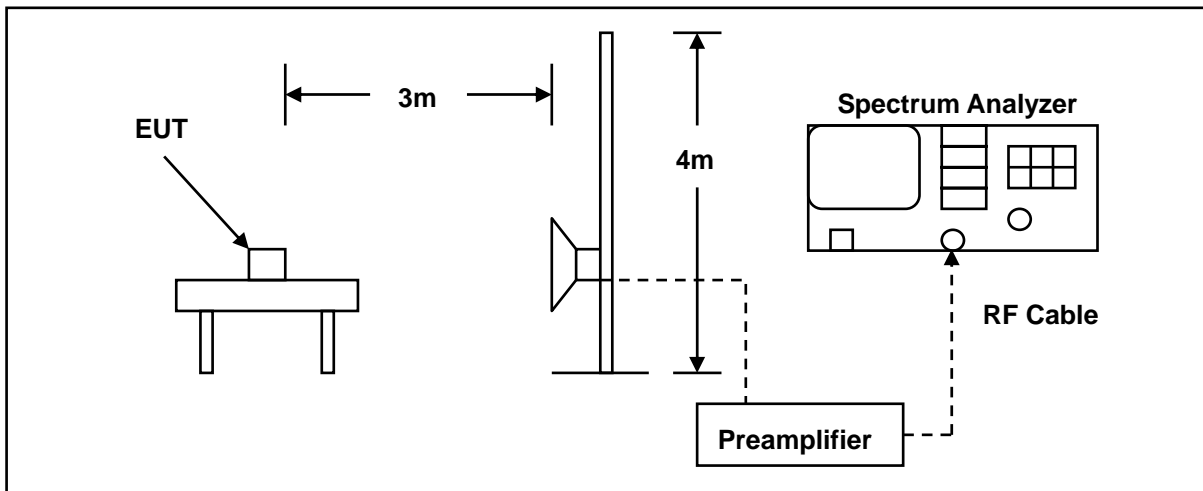

10.3.Test Instruments

3 Meter Chamber					
Equipment	Manufacturer	Model Number	Serial Number	Cal. Date	Remark
RF Pre-selector	Agilent	N9039A	MY46520256	01/10/2014	(1)
Spectrum Analyzer	Agilent	E4446A	MY46180578	01/10/2014	(1)
Pre Amplifier	Agilent	8449B	3008A02237	02/21/2014	(1)
Pre Amplifier	Agilent	8447D	2944A10961	02/21/2014	(1)
Horn Antenna (1~18GHz)	SCHWARZBECK MESS-ELEKTRONIK	BBHA9120D	9120D-550	06/11/2014	(1)
Test Site	ATL	TE01	888001	08/28/2014	(1)

Remark: (1) Calibration period 1 year. (2) Calibration period 2 years. (3) Calibration period 3 years.

Note: N.C.R. = No Calibration Request.

10.4. Test Procedure

The EUT was setup to ANSI C63.4:2014; tested to DTS test procedure of KDB558074D01 for compliance to FCC 47CFR 15.247 requirements.

The emissions on the harmonics frequencies, the limits, and the margin of compliance are presented. These tests were made when the transmitter was in full radiated power. The additional test was performed to show compliance with the requirement at the band-edge frequency 2483.5 MHz and up to 2500 MHz and at 2390.0 MHz.

The transmitter was configured with the worst case antenna and setup to transmit at the highest channel. Then the field strength was measured at 2483.5 MHz.

The transmitter was then configured with the worst case antenna and setup to transmit at the lowest channel. Then the field strength was measured at 2390.0 MHz. These tests were performed at 4 different bit rates.

For measurements the resolution bandwidth is set to 1 MHz, and then the video bandwidth is set to 1 MHz for peak measurements and 10 Hz for average measurements.

10.5. Test Result

Standard:	FCC Part 15C		Test Distance:	3m			
Test item:	Radiated Emission		Power:	AC 120V/60Hz			
Model Number:	AC779S-200		Temp.(°C)/Hum.(%RH):	26(°C)/60%RH			
Mode:	2		Date:	12/04/2014			
Frequency:	2412 MHz		Test By:	Eric Ou Yang			
Frequency (MHz)	Reading (dBuV)	Correct Factor (dB/m)	Result (dBuV/m)	Limit (dBuV/m)	Margin (dB)	Remark	Ant.Polar. H / V
2330.570	51.46	-2.51	48.95	74.00	-25.05	peak	H
2390.000	49.08	-2.24	46.84	74.00	-27.16	peak	H
2374.790	52.01	-2.31	49.70	74.00	-24.30	peak	V
2390.000	49.96	-2.24	47.72	74.00	-26.28	peak	V

Standard:	FCC Part 15C		Test Distance:	3m			
Test item:	Radiated Emission		Power:	AC 120V/60Hz			
Model Number:	AC779S-200		Temp.(°C)/Hum.(%RH):	26(°C)/60%RH			
Mode:	2		Date:	12/04/2014			
Frequency:	2462 MHz		Test By:	Eric Ou Yang			
Frequency (MHz)	Reading (dBuV)	Correct Factor (dB/m)	Result (dBuV/m)	Limit (dBuV/m)	Margin (dB)	Remark	Ant.Polar. H / V
2483.500	48.83	-1.83	47.00	74.00	-27.00	peak	H
2483.880	51.70	-1.82	49.88	74.00	-24.12	peak	H
2483.500	49.19	-1.83	47.36	74.00	-26.64	peak	V
2495.360	51.30	-1.78	49.52	74.00	-24.48	peak	V

Standard:	FCC Part 15C	Test Distance:	3m
Test item:	Radiated Emission	Power:	AC 120V/60Hz
Model Number:	AC779S-200	Temp.(°C)/Hum.(%RH):	26(°C)/60%RH
Mode:	3	Date:	12/04/2014
Frequency:	2412 MHz	Test By:	Eric Ou Yang

Frequency (MHz)	Reading (dBuV)	Correct Factor (dB/m)	Result (dBuV/m)	Limit (dBuV/m)	Margin (dB)	Remark	Ant.Polar. H / V
2389.420	52.82	-2.25	50.57	74.00	-23.43	peak	H
2390.000	54.06	-2.24	51.82	74.00	-22.18	peak	H
2352.460	51.58	-2.40	49.18	74.00	-24.82	peak	V
2390.000	48.42	-2.24	46.18	74.00	-27.82	peak	V

Standard:	FCC Part 15C	Test Distance:	3m
Test item:	Radiated Emission	Power:	AC 120V/60Hz
Model Number:	AC779S-200	Temp.(°C)/Hum.(%RH):	26(°C)/60%RH
Mode:	3	Date:	12/04/2014
Frequency:	2462 MHz	Test By:	Eric Ou Yang

Frequency (MHz)	Reading (dBuV)	Correct Factor (dB/m)	Result (dBuV/m)	Limit (dBuV/m)	Margin (dB)	Remark	Ant.Polar. H / V
2483.500	60.22	-1.83	58.39	74.00	-15.61	peak	H
2483.500	47.72	-1.83	45.89	54.00	-8.11	AVG	H
2483.960	65.01	-1.82	63.19	74.00	-10.81	peak	H
2483.960	46.84	-1.82	45.02	54.00	-8.98	AVG	H
2483.500	53.64	-1.83	51.81	74.00	-22.19	peak	V
2483.960	57.58	-1.82	55.76	74.00	-18.24	peak	V
2483.960	42.08	-1.82	40.26	54.00	-13.74	AVG	V

Standard:	FCC Part 15C			Test Distance:	3m		
Test item:	Radiated Emission			Power:	AC 120V/60Hz		
Model Number:	AC779S-200			Temp.(°C)/Hum.(%RH):	26(°C)/60%RH		
Mode:	4			Date:	12/04/2014		
Frequency:	2412 MHz			Test By:	Eric Ou Yang		
Frequency (MHz)	Reading (dBuV)	Correct Factor (dB/m)	Result (dBuV/m)	Limit (dBuV/m)	Margin (dB)	Remark	Ant.Polar. H / V
2389.530	58.12	-2.25	55.87	74.00	-18.13	peak	H
2389.530	41.20	-2.25	38.95	54.00	-15.05	AVG	H
2390.000	59.83	-2.24	57.59	74.00	-16.41	peak	H
2390.000	42.19	-2.24	39.95	54.00	-14.05	AVG	H
2336.510	51.31	-2.48	48.83	74.00	-25.17	peak	V
2390.000	49.59	-2.24	47.35	74.00	-26.65	peak	V

Standard:	FCC Part 15C			Test Distance:	3m		
Test item:	Radiated Emission			Power:	AC 120V/60Hz		
Model Number:	AC779S-200			Temp.(°C)/Hum.(%RH):	26(°C)/60%RH		
Mode:	4			Date:	12/04/2014		
Frequency:	2462 MHz			Test By:	Eric Ou Yang		
Frequency (MHz)	Reading (dBuV)	Correct Factor (dB/m)	Result (dBuV/m)	Limit (dBuV/m)	Margin (dB)	Remark	Ant.Polar. H / V
2483.500	65.72	-1.83	63.89	74.00	-10.11	peak	H
2483.500	50.05	-1.83	48.22	54.00	-5.78	AVG	H
2483.640	66.90	-1.83	65.07	74.00	-8.93	peak	H
2483.640	49.78	-1.83	47.95	54.00	-6.05	AVG	H
2483.500	57.14	-1.83	55.31	74.00	-18.69	peak	V
2483.500	44.85	-1.83	43.02	54.00	-10.98	AVG	V
2483.720	59.41	-1.83	57.58	74.00	-16.42	peak	V
2483.720	44.75	-1.83	42.92	54.00	-11.08	AVG	V

Standard:	FCC Part 15C			Test Distance:	3m		
Test item:	Radiated Emission			Power:	AC 120V/60Hz		
Model Number:	AC779S-200			Temp.(°C)/Hum.(%RH):	26(°C)/60%RH		
Mode:	5			Date:	12/04/2014		
Frequency:	2422 MHz			Test By:	Eric Ou Yang		
Frequency (MHz)	Reading (dBuV)	Correct Factor (dB/m)	Result (dBuV/m)	Limit (dBuV/m)	Margin (dB)	Remark	Ant.Polar. H / V
2388.960	57.48	-2.25	55.23	74.00	-18.77	peak	H
2388.960	45.31	-2.25	43.06	54.00	-10.94	AVG	H
2390.000	56.54	-2.24	54.30	74.00	-19.70	peak	H
2390.000	46.08	-2.24	43.84	54.00	-10.16	AVG	H
2358.480	51.56	-2.38	49.18	74.00	-24.82	peak	V
2390.000	49.79	-2.24	47.55	74.00	-26.45	peak	V

Standard:	FCC Part 15C			Test Distance:	3m		
Test item:	Radiated Emission			Power:	AC 120V/60Hz		
Model Number:	AC779S-200			Temp.(°C)/Hum.(%RH):	26(°C)/60%RH		
Mode:	5			Date:	12/04/2014		
Frequency:	2452 MHz			Test By:	Eric Ou Yang		
Frequency (MHz)	Reading (dBuV)	Correct Factor (dB/m)	Result (dBuV/m)	Limit (dBuV/m)	Margin (dB)	Remark	Ant.Polar. H / V
2483.500	65.82	-1.83	63.99	74.00	-10.01	peak	H
2483.500	52.58	-1.83	50.75	54.00	-3.25	AVG	H
2483.650	66.29	-1.83	64.46	74.00	-9.54	peak	H
2483.650	52.47	-1.83	50.64	54.00	-3.36	AVG	H
2483.500	57.09	-1.83	55.26	74.00	-18.74	peak	V
2483.500	46.60	-1.83	44.77	54.00	-9.23	AVG	V
2483.900	59.60	-1.82	57.78	74.00	-16.22	peak	V
2483.900	46.46	-1.82	44.64	54.00	-9.36	AVG	V

11 Antenna Measurement

11.1.Limit

For intentional device, according to 15.203, an intentional radiator shall be designed to ensure that no antenna other than that furnished by the responsible party shall be used with the device.

And According to 15.247 (b), if transmitting antennas of directional gain greater than 6 dBi are used, the power shall be reduced by the amount in dB that the directional gain of the antenna exceeds 6dBi.

11.2.Antenna Connector Construction

The antenna used in this product is FPC Antenna. And the maximum Gain of this antenna is only 1.45 dBi.