

TEST REPORT

CERTIFICATE OF CONFORMITY

Standard: 47 CFR FCC Part 15, Subpart E (Section 15.407)

Report No.: RFBBQZ-WTW-P24020178-1

FCC ID: PY323400615

Product: NIGHTHAWK BE6500 WiFi 7 Router, NIGHTHAWK BE5000 WiFi 7 Router, NIGHTHAWK BE4300 WiFi 7 Router (refer to item 3.1 for more details)

Brand: NETGEAR

Model No.: RS200

Series Model: RS150, RS150v2, RS140 (refer to item 3.1 for more details)

Received Date: 2024/2/6

Test Date: 2024/5/9 ~ 2024/6/17

Issued Date: 2024/7/12

Applicant and Manufacturer: NETGEAR, INC.

Address: 350 East Plumeria Drive San Jose CA 95134

Issued By: Bureau Veritas Consumer Products Services (H.K.) Ltd., Taoyuan Branch
Lin Kou Laboratories

Lab Address: No. 47-2, 14th Ling, Chia Pau Vil., Lin Kou Dist., New Taipei City, Taiwan

Test Location: No. 19, Hwa Ya 2nd Rd., Wen Hwa Vil., Kewi Shan Dist., Taoyuan City 33383, Taiwan

FCC Registration / 788550 / TW0003

Designation Number:

Approved by: Jeremy Lin, Date: 2024/7/12
Jeremy Lin / Project Engineer

This test report consists of 144 pages in total. It may be duplicated completely for legal use with the approval of the applicant. It should not be reproduced except in full, without the written approval of our laboratory. The test results in the report only apply to the tested sample. The test results in this report are traceable to the national or international standards.

Prepared by : Polly Chien / Specialist



This report is governed by, and incorporates by reference, the Conditions of Testing as posted at the date of issuance of this report at <http://www.bureauveritas.com/home/about-us/our-business/cps/about-us/terms-conditions/> and is intended for your exclusive use. Any copying or replication of this report to or for any other person or entity, or use of our name or trademark, is permitted only with our prior written permission. This report sets forth our findings solely with respect to the test samples identified herein. The results set forth in this report are not indicative or representative of the quality or characteristics of the lot from which a test sample was taken or any similar or identical product unless specifically and expressly noted. Our report includes all of the tests requested by you and the results thereof based upon the information that you provided to us. Measurement uncertainty is only provided upon request for accredited tests. Statements of conformity are based on simple acceptance criteria without taking measurement uncertainty into account, unless otherwise requested in writing. You have 60 days from date of issuance of this report to notify us of any material error or omission caused by our negligence or if you require measurement uncertainty; provided, however, that such notice shall be in writing and shall specifically address the issue you wish to raise. A failure to raise such issue within the prescribed time shall constitute your unqualified acceptance of the completeness of this report, the tests conducted and the correctness of the report contents.

Table of Contents

Release Control Record	4
1 Certificate	5
2 Summary of Test Results	6
2.1 Measurement Uncertainty	7
2.2 Supplementary Information	7
3 General Information	8
3.1 General Description of EUT	8
3.2 Antenna Description of EUT	10
3.3 Channel List	11
3.4 Test Mode Applicability and Tested Channel Detail	13
3.5 Duty Cycle of Test Signal	15
3.6 Test Program Used and Operation Descriptions	17
3.7 Connection Diagram of EUT and Peripheral Devices	17
3.8 Configuration of Peripheral Devices and Cable Connections	17
4 Test Instruments	18
4.1 26 dB Bandwidth	18
4.2 RF Output Power	18
4.3 Power Spectral Density	18
4.4 6 dB Bandwidth	18
4.5 Occupied Bandwidth	18
4.6 Frequency Stability	19
4.7 AC Power Conducted Emissions	19
4.8 Unwanted Emissions below 1 GHz	20
4.9 Unwanted Emissions above 1 GHz	21
5 Limits of Test Items	22
5.1 26 dB Bandwidth	22
5.2 RF Output Power	22
5.3 Power Spectral Density	22
5.4 6 dB Bandwidth	22
5.5 Occupied Bandwidth	22
5.6 Frequency Stability	23
5.7 AC Power Conducted Emissions	23
5.8 Unwanted Emissions below 1 GHz	23
5.9 Unwanted Emissions above 1 GHz	24
6 Test Arrangements	26
6.1 26 dB Bandwidth	26
6.1.1 Test Setup	26
6.1.2 Test Procedure	26
6.2 RF Output Power	26
6.2.1 Test Setup	26
6.2.2 Test Procedure	26
6.3 Power Spectral Density	27
6.3.1 Test Setup	27
6.3.2 Test Procedure	27
6.4 6 dB Bandwidth	27
6.4.1 Test Setup	27
6.4.2 Test Procedure	27
6.5 Occupied Bandwidth	28
6.5.1 Test Setup	28
6.5.2 Test Procedure	28
6.6 Frequency Stability	28
6.6.1 Test Setup	28
6.6.2 Test Procedure	28
6.7 AC Power Conducted Emissions	29



6.7.1	Test Setup	29
6.7.2	Test Procedure	29
6.8	Unwanted Emissions below 1 GHz	30
6.8.1	Test Setup	30
6.8.2	Test Procedure	31
6.9	Unwanted Emissions above 1 GHz	32
6.9.1	Test Setup	32
6.9.2	Test Procedure	32
7	Test Results of Test Item	33
7.1	26 dB Bandwidth	33
7.2	RF Output Power	38
7.3	Power Spectral Density	51
7.4	6 dB Bandwidth	59
7.5	Occupied Bandwidth	61
7.6	Frequency Stability	70
7.7	AC Power Conducted Emissions	71
7.8	Unwanted Emissions below 1 GHz	73
7.9	Unwanted Emissions above 1 GHz	75
8	Pictures of Test Arrangements	143
9	Information of the Testing Laboratories	144



Release Control Record

Issue No.	Description	Date Issued
RFBBQZ-WTW-P24020178-1	Original release.	2024/7/12

1 Certificate

Product: NIGHTHAWK BE6500 WiFi 7 Router, NIGHTHAWK BE5000 WiFi 7 Router, NIGHTHAWK BE4300 WiFi 7 Router (refer to item 3.1 for more details)

Brand: NETGEAR

Test Model: RS200

Series Model: RS150, RS150v2, RS140 (refer to item 3.1 for more details)

Sample Status: Engineering sample

**Applicant and
Manufacturer:** NETGEAR, INC.

Test Date: 2024/5/9 ~ 2024/6/17

Standard: 47 CFR FCC Part 15, Subpart E (Section 15.407)

**Measurement
procedure:** ANSI C63.10-2013
KDB 789033 D02 General UNII Test Procedure New Rules v02r01
KDB 662911 D01 Multiple Transmitter Output v02r01

The above equipment has been tested by **Bureau Veritas Consumer Products Services (H.K.) Ltd., Taoyuan Branch**, and found compliance with the requirement of the above standards. The test record, data evaluation & Equipment Under Test (EUT) configurations represented herein are true and accurate accounts of the measurements of the sample's RF characteristics under the conditions specified in this report.

2 Summary of Test Results

47 CFR FCC Part 15, Subpart E (Section 15.407)			
Clause	Test Item	Result	Remark
15.407(a)(2)	26 dB Bandwidth	-	For U-NII-2A U-NII-2C Band output power limitation is determined based on 26dBc bandwidth.
15.407(a)(1) 15.407(a)(2) 15.407(a)(3)	RF Output Power	Pass	Meet the requirement of limit.
15.407(a)(1) 15.407(a)(2) 15.407(a)(3)	Power Spectral Density	Pass	Meet the requirement of limit.
15.407(e)	6 dB Bandwidth	Pass	Meet the requirement of limit. (U-NII-3 Band only)
---	Occupied Bandwidth	-	Reference only.
15.407(g)	Frequency Stability	Pass	Meet the requirement of limit.
15.407(b)(9)	AC Power Conducted Emissions	Pass	Minimum passing margin is -18.82 dB at 0.18600 MHz
15.407(b)(9)	Unwanted Emissions below 1 GHz	Pass	Minimum passing margin is -6.5 dB at 50.37 MHz
15.407(b) (1/10) 15.407(b) (2/10) 15.407(b) (3/10) 15.407(b) (4(i)/10)	Unwanted Emissions above 1 GHz	Pass	Minimum passing margin is -0.3 dB at 5150.00 MHz
15.203	Antenna Requirement	Pass	Antenna connector is ipex(MHF) not a standard connector.

Notes:

1. Determining compliance based on the results of the compliance measurement, not taking into account measurement instrumentation uncertainty.
2. The "Dynamic Frequency Selection measurement" was recorded in DFS test report.

2.1 Measurement Uncertainty

Where relevant, the following measurement uncertainty levels have been estimated for tests performed on the EUT as specified in CISPR 16-4-2:

Measurement	Specification	Expanded Uncertainty (k=2) (±)
26 dB Bandwidth	-	206.5 Hz
RF Output Power	-	1.371 dB
Power Spectral Density	-	1.017 dB
6 dB Bandwidth	-	206.5 Hz
Occupied Bandwidth	-	72 Hz
Frequency Stability	-	0.176 ppm
AC Power Conducted Emissions	9 kHz ~ 30 MHz	2.90 dB
Unwanted Emissions below 1 GHz	9 kHz ~ 30 MHz	3.59 dB
	30 MHz ~ 1 GHz	3.64 dB
Unwanted Emissions above 1 GHz	1 GHz ~ 18 GHz	2.29 dB
	18 GHz ~ 40 GHz	2.29 dB

The other instruments specified are routine verified to remain within the calibrated levels, no measurement uncertainty is required to be calculated.

2.2 Supplementary Information

There is not any deviation from the test standards for the test method, and no modifications required for compliance.

3 General Information

3.1 General Description of EUT

Product	NIGHTHAWK BE6500 WiFi 7 Router, NIGHTHAWK BE5000 WiFi 7 Router, NIGHTHAWK BE4300 WiFi 7 Router (Refer to note)
Brand	NETGEAR
Test Model	RS200
Series Model	RS150, RS150v2, RS140
Model Difference	Refer to note
Status of EUT	Engineering sample
Power Supply Rating	12 Vdc from adapter
Modulation Type	64QAM, 16QAM, QPSK, BPSK for OFDM 256QAM for OFDM in 11ac mode 1024QAM for OFDMA in 11ax mode 4096QAM for OFDMA in 11be mode
Modulation Technology	OFDM, OFDMA
Transfer Rate	Up to 5764 Mbps
Operating Frequency	5.18 GHz ~ 5.25 GHz 5.25 GHz ~ 5.32 GHz 5.50 GHz ~ 5.72 GHz 5.745 GHz ~ 5.825 GHz
Number of Channel	802.11a, 802.11n (HT20), 802.11ac (VHT20), 802.11ax (HE20), 802.11be (EHT20): 25 802.11n (HT40), 802.11ac (VHT40), 802.11ax (HE40), 802.11be (EHT40): 12 802.11ac (VHT80), 802.11ax (HE80), 802.11be (EHT80): 6 802.11ac (VHT160), 802.11ax (HE160), 802.11be (EHT160): 2
Output Power	5.18 GHz ~ 5.25 GHz : 847.316 mW (29.28 dBm) 5.25 GHz ~ 5.32 GHz : 211.959 mW (23.26 dBm) 5.50 GHz ~ 5.72 GHz : 211.187 mW (23.25 dBm) 5.745 GHz ~ 5.825 GHz : 863.959 mW (29.36 dBm)
EUT Category	Indoor Access Point

Note:

1. The following product and models are as below. The model of the RS200 was chosen for final test.

Product	Model	remark
NIGHTHAWK BE6500 WiFi 7 Router	RS200	2.4GHz (2 x 2): 0.7 Gbps 5GHz (4 x 4): 5.8 Gbps
NIGHTHAWK BE5000 WiFi 7 Router	RS150	2.4GHz (2 x 2): 0.7 Gbps 5GHz (3 x 3): 4.3 Gbps
	RS150v2	2.4GHz (2 x 2): 0.7 Gbps 5GHz (3 x 3): 4.3 Gbps
NIGHTHAWK BE4300 WiFi 7 Router	RS140	2.4GHz (2 x 2): 0.7 Gbps 5GHz (3 x 3): 3.6 Gbps

2. The EUT uses following accessories.

AC Adapter 1			
Brand	Model	Part Number	Specification
NETGEAR	ADS-40FPC-12 12030E	332-11699-01	AC Input: 100-240 Vac, 50/60 Hz, 1.0 A DC Output: 12.0 Vdc, 2.5 A, 30 W DC Output Cable: 1.76 m / 0 core Plug: US/EU/AU Manufacturer: Vietnam Honor High Tech Company Limited

AC Adapter 2			
Brand	Model	Part Number	Specification
NETGEAR	2AED030FC	332-11712-01	AC Input: 100-240 Vac, 50/60 Hz, 1.0 A DC Output: 12.0 Vdc, 2.5 A, 30.0W DC Output Cable: 1.8 m / 0 core Plug: US/EU/AU Manufacturer: Channel Well Technology(Guangzhou) Co., Ltd
Ethernet Cable			
Brand	Model	Specification	
NETGEAR	N/A	Signal Line: 1.96 m	

3. Simultaneously transmission condition.

Condition	Technology	
1	WLAN (2.4GHz)	WLAN (5GHz)

Note: The emission of the simultaneous operation has been evaluated and no non-compliance was found.

4. The above EUT information is declared by manufacturer and for more detailed features description, please refer to the manufacturer's specifications or user's manual.

3.2 Antenna Description of EUT

1. The antenna information is listed as below.

Antenna Type	Dipole
Connector Type	ipex(MHF)
Antenna Gain	Directional Gain (dBi)
2400~2483.5 MHz	3.81
5150~5250 MHz	6.05
5250~5350 MHz	6.06
5470~5725 MHz	6.21
5725~5850 MHz	6.33

*The detailed antenna information, please refer to the BV CPS Directional Gain Measurement Report no.: RFBBQZ-WTW-P24020178-5.

2. The EUT incorporates a MIMO function:

Modulation Mode	Tx & Rx Configuration	
802.11a	4TX	4RX
802.11n (HT20)	4TX	4RX
802.11n (HT40)	4TX	4RX
802.11ac (VHT20)	4TX	4RX
802.11ac (VHT40)	4TX	4RX
802.11ac (VHT80)	4TX	4RX
802.11ac (VHT160)	4TX	4RX
802.11ax (HE20)	4TX	4RX
802.11ax (HE40)	4TX	4RX
802.11ax (HE80)	4TX	4RX
802.11ax (HE160)	4TX	4RX
802.11be (EHT20)	4TX	4RX
802.11be (EHT40)	4TX	4RX
802.11be (EHT80)	4TX	4RX
802.11be (EHT160)	4TX	4RX

Note:

1. All of modulation mode support beamforming function except 802.11a modulation mode.
2. The EUT support Beamforming and CDD mode, therefore both mode were investigated and the worst case scenario was identified. The worst case data were presented in test report.
3. The modulation and bandwidth are similar for 802.11n mode for 20 MHz (40 MHz), 802.11ac mode for 20 MHz (40 MHz, 80 MHz, 160MHz), 802.11ax mode for 20 MHz (40 MHz, 80 MHz, 160MHz), and 802.11be mode for 20 MHz (40 MHz, 80 MHz, 160MHz), therefore the manufacturer will control the power for 802.11n/ac/ax mode is the same as the 802.11be or lower than it and investigated worst case to representative mode in test report.
4. For 802.11ax/be, the EUT not support Partial RU (resource unit) and channel puncturing/bandwidth reduction mechanisms.

3.3 Channel List

FOR 5180 ~ 5320 MHz

8 channels are provided for 802.11a, 802.11n (HT20), 802.11ac (VHT20), 802.11ax (HE20), 802.11be (EHT20):

Channel	Frequency	Channel	Frequency
36	5180 MHz	52	5260 MHz
40	5200 MHz	56	5280 MHz
44	5220 MHz	60	5300 MHz
48	5240 MHz	64	5320 MHz

4 channels are provided for 802.11n (HT40), 802.11ac (VHT40), 802.11ax (HE40), 802.11be (EHT40):

Channel	Frequency	Channel	Frequency
38	5190 MHz	54	5270 MHz
46	5230 MHz	62	5310 MHz

2 channels are provided for 802.11ac (VHT80), 802.11ax (HE80), 802.11be (EHT80):

Channel	Frequency	Channel	Frequency
42	5210 MHz	58	5290 MHz

1 straddle channel is provided for 802.11ac (VHT160), 802.11ax (HE160), 802.11be (EHT160):

Channel	Frequency
50	5250 MHz

FOR 5500 ~ 5720 MHz

12 channels are provided for 802.11a, 802.11n (HT20), 802.11ac (VHT20), 802.11ax (HE20), 802.11be (EHT20):

Channel	Frequency	Channel	Frequency
100	5500 MHz	124	5620 MHz
104	5520 MHz	128	5640 MHz
108	5540 MHz	132	5660 MHz
112	5560 MHz	136	5680 MHz
116	5580 MHz	140	5700 MHz
120	5600 MHz	144	5720 MHz

6 channels are provided for 802.11n (HT40), 802.11ac (VHT40), 802.11ax (HE40), 802.11be (EHT40):

Channel	Frequency	Channel	Frequency
102	5510 MHz	126	5630 MHz
110	5550 MHz	134	5670 MHz
118	5590 MHz	142	5710 MHz

3 channels are provided for 802.11ac (VHT80), 802.11ax (HE80), 802.11be (EHT80):

Channel	Frequency	Channel	Frequency
106	5530 MHz	138	5690 MHz
122	5610 MHz		

1 channel is provided for 802.11ac (VHT160), 802.11ax (HE160), 802.11be (EHT160):

Channel	Frequency
114	5570 MHz

FOR 5745 ~ 5825 MHz:

5 channels are provided for 802.11a, 802.11n (HT20), 802.11ac (VHT20), 802.11ax (HE20), 802.11be (EHT20):

Channel	Frequency	Channel	Frequency
149	5745 MHz	161	5805 MHz
153	5765 MHz	165	5825 MHz
157	5785 MHz		

2 channels are provided for 802.11n (HT40), 802.11ac (VHT40), 802.11ax (HE40), 802.11be (EHT40):

Channel	Frequency	Channel	Frequency
151	5755 MHz	159	5795 MHz

1 channel is provided for 802.11ac (VHT80), 802.11ax (HE80), 802.11be (EHT80):

Channel	Frequency
155	5775 MHz

3.4 Test Mode Applicability and Tested Channel Detail

Pre-Scan:	1. For Unwanted Emission (below 1GHz) and AC Power Conducted Emissions items: AC Adapter 1 and AC Adapter 2. Pre-scan these modes and find the worst case as a representative test condition. 2. Pre-Scan has been conducted to determine the worst-case mode from all possible combinations between available modulations, data rates and antenna ports (if EUT with antenna diversity architecture).
Worst Case:	1. AC Adapter 1 and AC Adapter 2 Worst Condition: AC Adapter 1 2. The EUT is designed to be positioned on the Z-Plane only.

Following channel(s) was (were) selected for the final test as listed below:

Test Item	Mode	Signal Mode	Tested Channel	Modulation	Data Rate Parameter
26 dB Bandwidth	802.11a	CDD	52, 60, 64, 100, 116, 140, 144	BPSK	6Mb/s
	802.11be (EHT20)	CDD	52, 60, 64, 100, 116, 140, 144	BPSK	MCS0
	802.11be (EHT40)	CDD	54, 62, 102, 110, 134, 142	BPSK	MCS0
	802.11be (EHT80)	CDD	58, 106, 122, 138	BPSK	MCS0
	802.11be (EHT160)	CDD	50, 114	BPSK	MCS0
RF Output Power	802.11a	CDD	36, 40, 48, 52, 60, 64, 100, 116, 140, 144, 149, 157, 165	BPSK	6Mb/s
	802.11be (EHT20)	CDD & Beamforming	36, 40, 48, 52, 60, 64, 100, 116, 140, 144, 149, 157, 165	BPSK	MCS0
	802.11be (EHT40)	CDD & Beamforming	38, 46, 54, 62, 102, 110, 134, 142, 151, 159	BPSK	MCS0
	802.11be (EHT80)	CDD & Beamforming	42, 58, 106, 122, 138, 155	BPSK	MCS0
	802.11be (EHT160)	CDD & Beamforming	50, 114	BPSK	MCS0
Power Spectral Density	802.11a	CDD	36, 40, 48, 52, 60, 64, 100, 116, 140, 144, 149, 157, 165	BPSK	6Mb/s
	802.11be (EHT20)	CDD	36, 40, 48, 52, 60, 64, 100, 116, 140, 144, 149, 157, 165	BPSK	MCS0
	802.11be (EHT40)	CDD	38, 46, 54, 62, 102, 110, 134, 142, 151, 159	BPSK	MCS0
	802.11be (EHT80)	CDD	42, 58, 106, 122, 138, 155	BPSK	MCS0
	802.11be (EHT160)	CDD	50, 114	BPSK	MCS0
6 dB Bandwidth	802.11a	CDD	144, 149, 157, 165	BPSK	6Mb/s
	802.11be (EHT20)	CDD	144, 149, 157, 165	BPSK	MCS0
	802.11be (EHT40)	CDD	142, 151, 159	BPSK	MCS0
	802.11be (EHT80)	CDD	138, 155	BPSK	MCS0
Occupied Bandwidth	802.11a	CDD	36, 40, 48, 52, 60, 64, 100, 116, 140, 144, 149, 157, 165	BPSK	6Mb/s
	802.11be (EHT20)	CDD	36, 40, 48, 52, 60, 64, 100, 116, 140, 144, 149, 157, 165	BPSK	MCS0
	802.11be (EHT40)	CDD	38, 46, 54, 62, 102, 110, 134, 142, 151, 159	BPSK	MCS0
	802.11be (EHT80)	CDD	42, 58, 106, 122, 138, 155	BPSK	MCS0
	802.11be (EHT160)	CDD	50, 114	BPSK	MCS0

Test Item	Mode	Signal Mode	Tested Channel	Modulation	Data Rate Parameter
Frequency Stability	802.11a	-	36	un-modulation	-
AC Power Conducted Emissions	802.11be (EHT40)	CDD	151	BPSK	MCS0
Unwanted Emissions below 1 GHz	802.11be (EHT40)	CDD	151	BPSK	MCS0
Unwanted Emissions above 1 GHz	802.11a	CDD	36, 40, 48, 52, 60, 64, 100, 116, 140, 144, 149, 157, 165	BPSK	6Mb/s
	802.11be (EHT20)	CDD	36, 40, 48, 52, 60, 64, 100, 116, 140, 144, 149, 157, 165	BPSK	MCS0
	802.11be (EHT40)	CDD	38, 46, 54, 62, 102, 110, 134, 142, 151, 159	BPSK	MCS0
	802.11be (EHT80)	CDD	42, 58, 106, 122, 138, 155	BPSK	MCS0
	802.11be (EHT160)	CDD	50, 114	BPSK	MCS0
Note: Partial RU (resource unit), channel puncturing and bandwidth reduction mechanisms are not supported.					

3.5 Duty Cycle of Test Signal

802.11a: Duty cycle = 3.02 ms / 3.03 ms x 100% = 99.7%

802.11be (EHT20): Duty cycle = 2.88 ms / 2.89 ms x 100% = 99.7%

802.11be (EHT40): Duty cycle = 2.86 ms / 2.87 ms x 100% = 99.7%

802.11be (EHT80): Duty cycle = 2.86 ms / 2.87 ms x 100% = 99.7%

802.11be (EHT160): Duty cycle = 2.86 ms / 2.87 ms x 100% = 99.7%

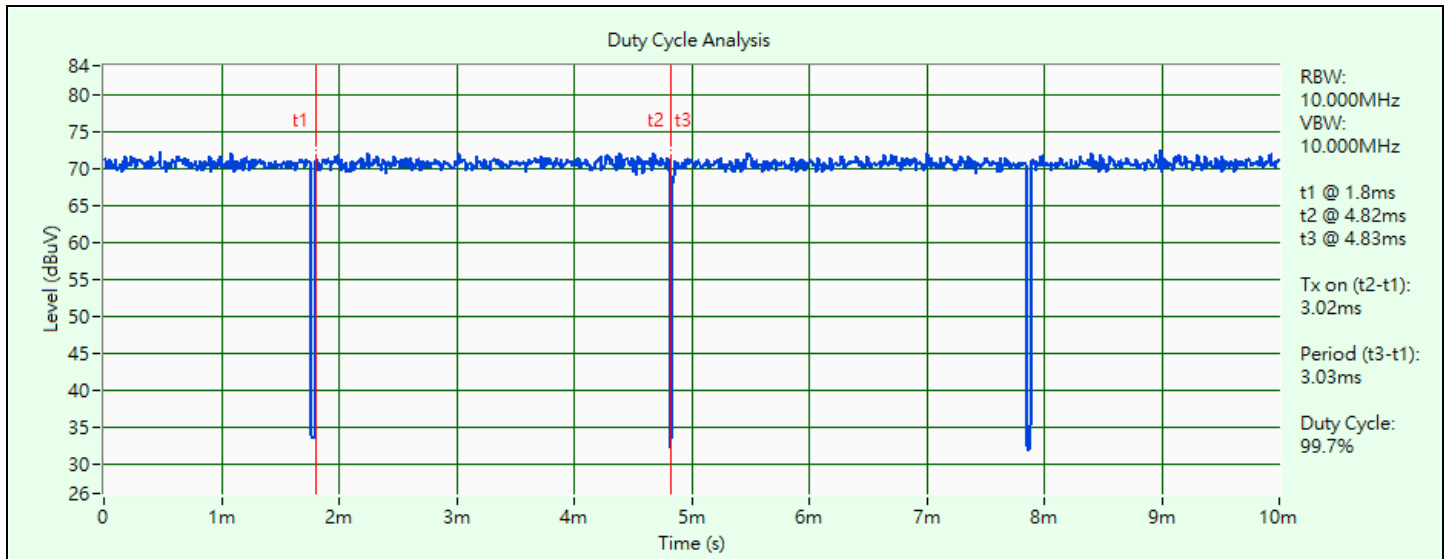

802.11a

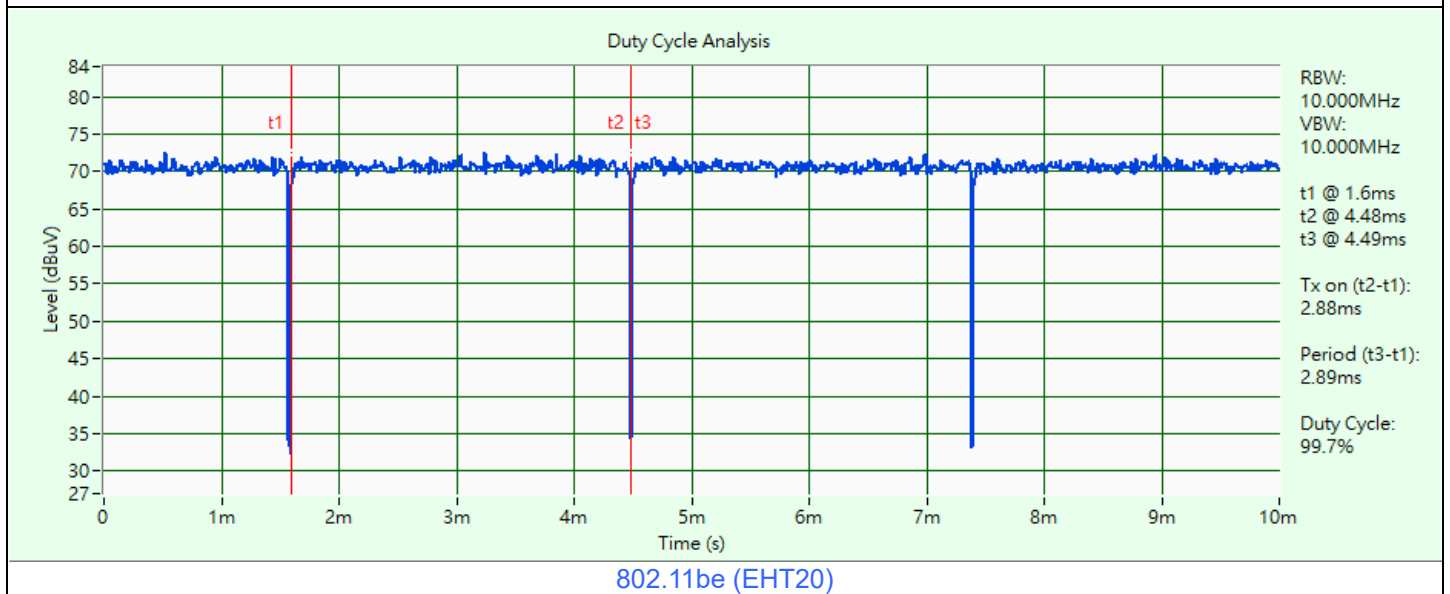

802.11be (EHT20)

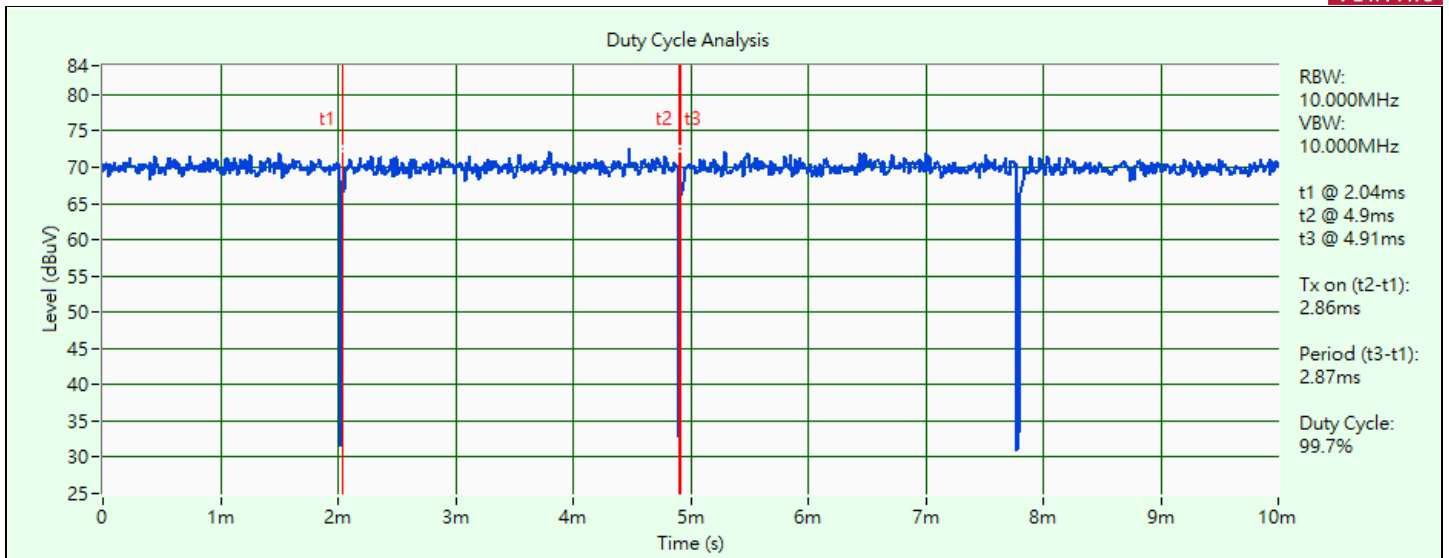

802.11be (EHT40)

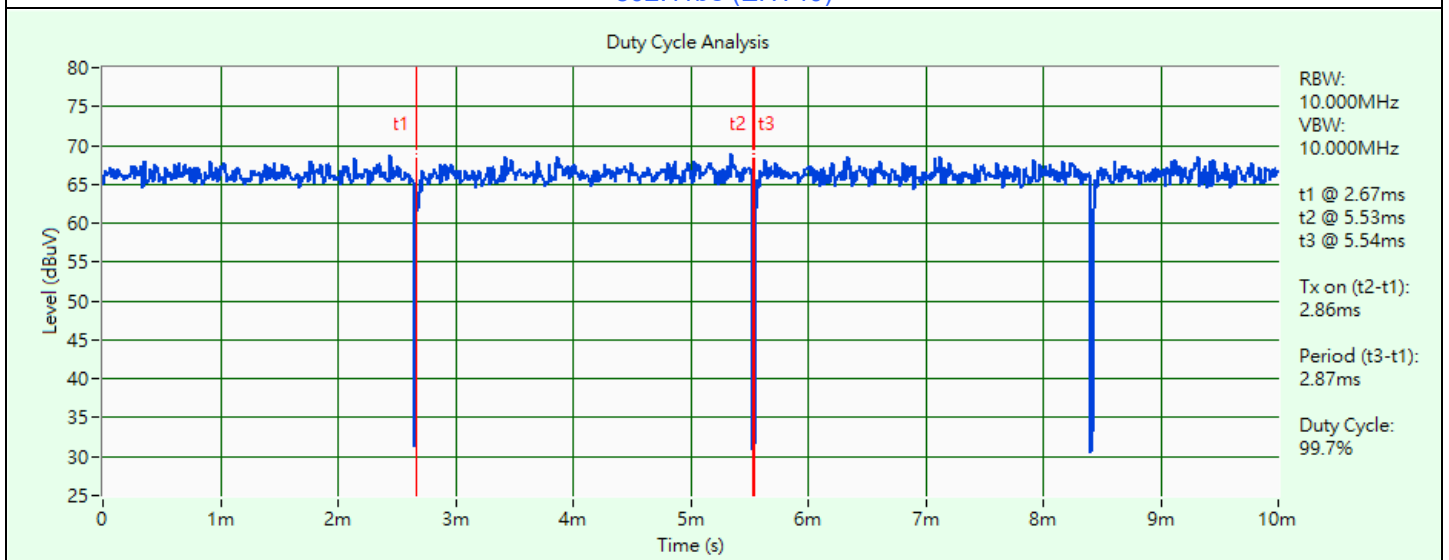

802.11be (EHT80)

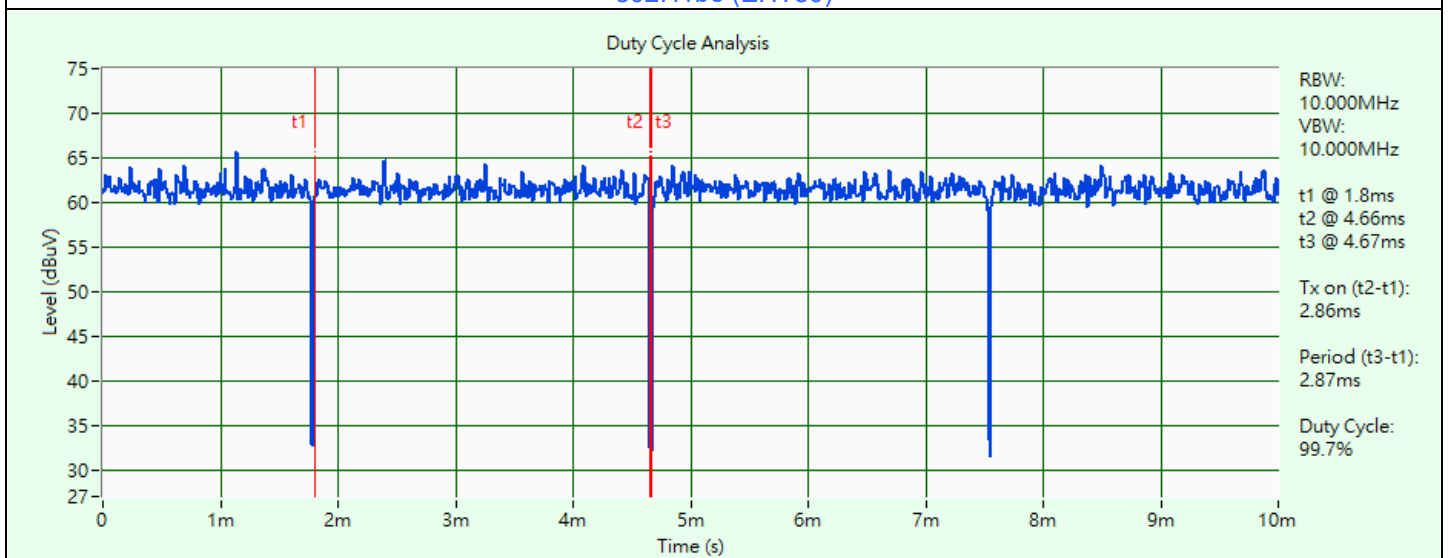

802.11be (EHT160)

3.6 Test Program Used and Operation Descriptions

Controlling software Access manual Tool 3.2.1.5 has been activated to set the EUT under transmission condition continuously at specific channel frequency.

3.7 Connection Diagram of EUT and Peripheral Devices

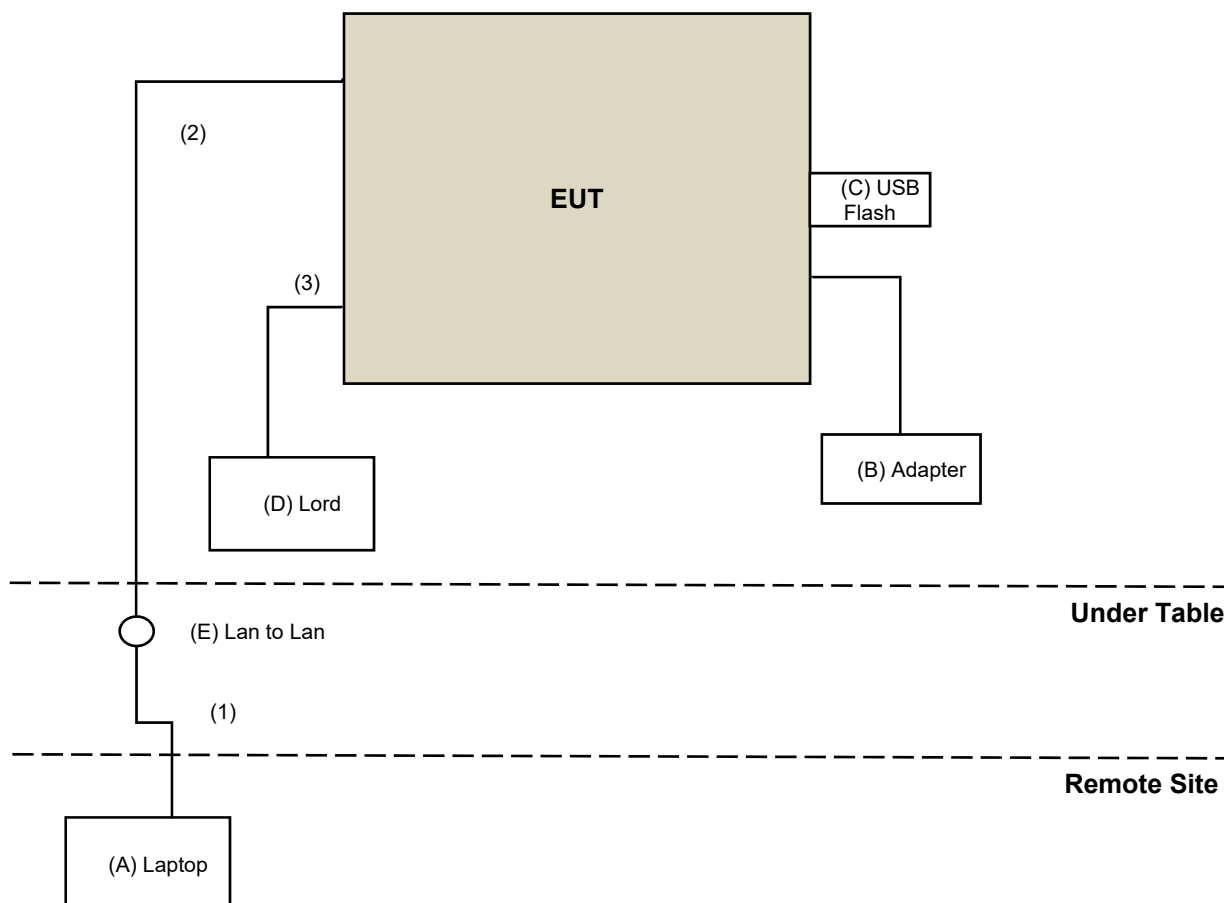

3.8 Configuration of Peripheral Devices and Cable Connections

ID	Product	Brand	Model No.	Serial No.	FCC ID	Remarks
A	Laptop	DELL	E5430	2RL3YW1	N/A	Provided by Lab
B	Adapter	NETGEAR	ADS-40FPC-12 12030E	N/A	N/A	Supplied by applicant
C	USB Flash	SanDisk	SDDDC3-032G	N/A	N/A	Provided by Lab
D	Lord	N/A	N/A	N/A	N/A	Provided by Lab
E	Lan to Lan	N/A	N/A	N/A	N/A	Provided by Lab

ID	Cable Descriptions	Qty.	Length (m)	Shielding (Yes/No)	Cores (Qty.)	Remarks
1	RJ-45 Cable	1	10	N	N	Provided by Lab
2	RJ-45 Cable	1	1.96	N	N	Accessory of EUT
3	RJ-45 Cable	4	1.5	N	N	Provided by Lab

4 Test Instruments

The calibration interval of the all test instruments are 12 months and the calibrations are traceable to NML/ROC and NIST/USA.

4.1 26 dB Bandwidth

Description Manufacturer	Model No.	Serial No.	Calibrated Date	Calibrated Until
Signal & Spectrum Analyzer R&S	FSV3044	101105	2024/2/27	2025/2/26
Software BV	ADT_RF Test Software V7.6.5.4	N/A	N/A	N/A

Notes:

1. The test was performed in Oven room.
2. Tested Date: 2024/6/17

4.2 RF Output Power

Description Manufacturer	Model No.	Serial No.	Calibrated Date	Calibrated Until
Peak Power Analyzer Keysight	8990B	MY51000485	2024/1/21	2025/1/20
Signal & Spectrum Analyzer R&S	FSV3044	101105	2024/2/27	2025/2/26
Software BV	ADT_RF Test Software V7.6.5.4	N/A	N/A	N/A
Wideband Power Sensor Keysight	N1923A	MY58020002	2024/1/18	2025/1/17
		MY58140009	2024/1/18	2025/1/17

Notes:

1. The test was performed in Oven room.
2. Tested Date: 2024/6/17

4.3 Power Spectral Density

Refer to section 4.1 to get the tested date and information of the instruments.

4.4 6 dB Bandwidth

Refer to section 4.1 to get the tested date and information of the instruments.

4.5 Occupied Bandwidth

Refer to section 4.1 to get the tested date and information of the instruments.

4.6 Frequency Stability

Description Manufacturer	Model No.	Serial No.	Calibrated Date	Calibrated Until
AC Power Supply JIN YIH Technology	6905S	1720444	N/A	N/A
Digital Multimeter Fluke	87III	70360742	2023/7/6	2024/7/5
Signal & Spectrum Analyzer R&S	FSV3044	101105	2024/2/27	2025/2/26
Software BV	ADT_RF Test Software V7.6.5.4	N/A	N/A	N/A
Temperature & Humidity Chamber Terchy	HRM-120RF	931022	2023/12/19	2024/12/18

Notes:

1. The test was performed in Oven room.
2. Tested Date: 2024/6/17

4.7 AC Power Conducted Emissions

Description Manufacturer	Model No.	Serial No.	Calibrated Date	Calibrated Until
50 ohm terminal resistance HUBER+SUHNER	E1-011315	13	2023/11/22	2024/11/21
50 ohm terminal resistance	E1-011279	04	2023/11/22	2024/11/21
	E1-011280	05	2023/11/22	2024/11/21
DC-LISN Schwarzbeck	NNBM 8126G	8126G-069	2023/11/7	2024/11/6
EMI Test Receiver R&S	ESCI	100613	2023/12/4	2024/12/3
Fixed Attenuator Mini-Circuits	HAT-10+	PAD-COND1-01	2024/1/6	2025/1/5
LISN R&S	ENV216	101826	2024/3/25	2025/3/24
	ESH3-Z5	100311	2023/9/6	2024/9/5
RF Coaxial Cable Woken	5D-FB	Cable-cond1-01	2024/1/6	2025/1/5
Software BVADT	BVADT_Cond_ V7.4.1.0	N/A	N/A	N/A
V-LISN Schwarzbeck	NNBL 8226-2	8226-142	2023/8/31	2024/8/30

Notes:

1. The test was performed in HY - Conduction 1.
2. Tested Date: 2024/6/5

4.8 Unwanted Emissions below 1 GHz

Description Manufacturer	Model No.	Serial No.	Calibrated Date	Calibrated Until
Antenna Tower inn-co GmbH	MA 4000	010303	N/A	N/A
Bi_Log Antenna Schwarzbeck	VULB 9168	9168-155	2023/10/13	2024/10/12
EMI Test Receiver R&S	ESR3	102782	2023/12/7	2024/12/6
Loop Antenna Electro-Metrics	EM-6879	269	2023/9/23	2024/9/22
Loop Antenna TESEQ	HLA 6121	45745	2023/8/8	2024/8/7
Preamplifier Agilent	8447D	2944A10631	2024/5/1	2025/4/30
Preamplifier EMCI	EMC001340	980201	2023/9/27	2024/9/26
RF Coaxial Cable Woken	8D-FB	Cable-CH4-01	2023/7/8	2024/7/7
Signal & Spectrum Analyzer R&S	FSW43	101582	2024/4/12	2025/4/11
Software BV ADT	ADT_Radiated_ V7.6.15.9.5	N/A	N/A	N/A
Turn Table BV ADT	TT100	TT93021705	N/A	N/A
Turn Table Controller BV ADT	SC100	SC93021705	N/A	N/A

Notes:

1. The test was performed in HY - 966 chamber 3.
2. Tested Date: 2024/6/6

4.9 Unwanted Emissions above 1 GHz

Description Manufacturer	Model No.	Serial No.	Calibrated Date	Calibrated Until
Antenna Tower inn-co GmbH	MA 4000	010303	N/A	N/A
Boresight antenna tower fixture BV	BAF-02	5	N/A	N/A
EMI Test Receiver R&S	ESR3	102782	2023/12/7	2024/12/6
Horn Antenna Schwarzbeck	BBHA 9120D	9120D-408	2023/11/12	2024/11/11
	BBHA 9170	9170-480	2023/11/12	2024/11/11
		BBHA9170241	2023/10/16	2024/10/15
		BBHA9170243	2023/11/12	2024/11/11
Preamplifier EMCI	EMC 184045	980116	2023/9/27	2024/9/26
Preamplifier Keysight	83017A	MY53270295	2024/5/1	2025/4/30
RF Coaxial Cable EMCI	EMC102-KM-KM-600	150928	2023/7/8	2024/7/7
	EMC102-KM-KM-3000	150929	2023/7/8	2024/7/7
RF Coaxial Cable HUBER+SUHNER	SUCOFLEX 104	Cable-CH4-03(250724)	2024/5/1	2025/4/30
	Sucoflex 104	MY 13380+295012/04	2024/5/1	2025/4/30
Signal & Spectrum Analyzer R&S	FSW43	101582	2024/4/12	2025/4/11
Software BV ADT	ADT_Radiated_ V7.6.15.9.5	N/A	N/A	N/A
Turn Table BV ADT	TT100	TT93021705	N/A	N/A
Turn Table Controller BV ADT	SC100	SC93021705	N/A	N/A

Notes:

1. The test was performed in HY - 966 chamber 3.
2. Tested Date: 2024/5/9 ~ 2024/6/4

5 Limits of Test Items

5.1 26 dB Bandwidth

The results are for reference only.

5.2 RF Output Power

Operation Band	EUT Category	Limit
U-NII-1	Outdoor Access Point	1 Watt (30 dBm) (Max. e.i.r.p \leq 125mW(21 dBm) at any elevation angle above 30 degrees as measured from the horizon)
	Fixed point-to-point Access Point	1 Watt (30 dBm)
	Indoor Access Point	1 Watt (30 dBm)
	Mobile and Portable client device	250mW (24 dBm)

Operation Band	Limit
U-NII-2A	250 mW (24 dBm) or 11 dBm+10 log B*
U-NII-2C	250 mW (24 dBm) or 11 dBm+10 log B*
U-NII-3	1 Watt (30 dBm)

*B is the 26 dB emission bandwidth in megahertz

Per KDB 662911 D01 Multiple Transmitter Output Method of conducted output power measurement on IEEE 802.11 devices,

Array Gain = 0 dB (i.e., no array gain) for $N_{ANT} \leq 4$;

Array Gain = 0 dB (i.e., no array gain) for channel widths ≥ 40 MHz for any N_{ANT} ;

Array Gain = $5 \log(N_{ANT}/N_{SS})$ dB or 3 dB, whichever is less, for 20-MHz channel widths with $N_{ANT} \geq 5$.

For power measurements on all other devices: Array Gain = $10 \log(N_{ANT}/N_{SS})$ dB.

5.3 Power Spectral Density

Operation Band	EUT Category	Limit
U-NII-1	Outdoor Access Point	17 dBm/MHz
	Fixed point-to-point Access Point	
	Indoor Access Point	
	Mobile and Portable client device	11 dBm/MHz

Operation Band	Limit
U-NII-2A	11 dBm/MHz
U-NII-2C	11 dBm/MHz
U-NII-3	30 dBm/500 kHz

5.4 6 dB Bandwidth

Within the 5.725-5.850 GHz band, the minimum 6 dB bandwidth of U-NII devices shall be at least 500 kHz.

5.5 Occupied Bandwidth

The results are for reference only.

5.6 Frequency Stability

The frequency of the carrier signal shall be maintained within band of operation.

5.7 AC Power Conducted Emissions

Frequency (MHz)	Conducted Limit (dBuV)	
	Quasi-peak	Average
0.15 - 0.5	66 - 56	56 - 46
0.50 - 5.0	56	46
5.0 - 30.0	60	50

Notes:

1. The lower limit shall apply at the transition frequencies.
2. The limit decreases in line with the logarithm of the frequency in the range of 0.15 to 0.50 MHz.

5.8 Unwanted Emissions below 1 GHz

Radiated emissions which fall in the restricted bands must comply with the radiated emission limits specified as below table.

Frequencies (MHz)	Field Strength (microvolts/meter)	Measurement Distance (meters)
0.009 ~ 0.490	2400/F(kHz)	300
0.490 ~ 1.705	24000/F(kHz)	30
1.705 ~ 30.0	30	30
30 ~ 88	100	3
88 ~ 216	150	3
216 ~ 960	200	3
Above 960	500	3

Notes:

1. The lower limit shall apply at the transition frequencies.
2. Emission level (dBuV/m) = 20 log Emission level (uV/m).

5.9 Unwanted Emissions above 1 GHz

Radiated emissions which fall in the restricted bands must comply with the radiated emission limits specified as below table.

Frequencies (MHz)	Field Strength (microvolts/meter)	Measurement Distance (meters)
Above 960	500	3

Notes:

1. The lower limit shall apply at the transition frequencies.
2. Emission level (dBuV/m) = 20 log Emission level (uV/m).
3. For frequencies above 1000 MHz, the field strength limits are based on average detector, however, the peak field strength of any emission shall not exceed the maximum permitted average limits, specified above by more than 20 dB under any condition of modulation.

Limits of unwanted emission out of the restricted bands

Applicable To	Limit	
789033 D02 General UNII Test Procedure New Rules v02r01	Field Strength at 3 m	
	PK: 74 (dB μ V/m)	AV: 54 (dB μ V/m)

For transmitters operating in the 5.15-5.25 GHz band:

Applicable To	EIRP Limit	Equivalent Field Strength at 3 m
15.407(b)(1)	PK: -27 (dBm/MHz)	PK: 68.2 (dB μ V/m)

For transmitters operating in the 5.25-5.35 GHz band:

Applicable To	EIRP Limit	Equivalent Field Strength at 3 m
15.407(b)(2)	PK: -27 (dBm/MHz)	PK: 68.2 (dB μ V/m)

For transmitters operating in the 5.47-5.725 GHz band:

Applicable To	EIRP Limit	Equivalent Field Strength at 3 m
15.407(b)(3)	PK: -27 (dBm/MHz)	PK: 68.2 (dB μ V/m)

For transmitters operating in the 5.725-5.850 GHz band:

Applicable To	EIRP Limit	Equivalent Field Strength at 3 m
15.407(b)(4)(i)	PK: -27 (dBm/MHz) ^{*1} PK: 10 (dBm/MHz) ^{*2} PK: 15.6 (dBm/MHz) ^{*3} PK: 27 (dBm/MHz) ^{*4}	PK: 68.2 (dBμV/m) ^{*1} PK: 105.2 (dBμV/m) ^{*2} PK: 110.8 (dBμV/m) ^{*3} PK: 122.2 (dBμV/m) ^{*4}
^{*1} beyond 75 MHz or more above of the band edge. ^{*2} below the band edge increasing linearly to 10 dBm/MHz at 25 MHz above. ^{*3} below the band edge increasing linearly to a level of 15.6 dBm/MHz at 5 MHz above. ^{*4} from 5 MHz above or below the band edge increasing linearly to a level of 27 dBm/MHz at the band edge.		

Note: The following formula is used to convert the equipment isotropic radiated power (eirp) to field strength:

$$E = \frac{1000000 \sqrt{30P}}{3} \mu\text{V/m, where P is the eirp (Watts).}$$

6 Test Arrangements

6.1 26 dB Bandwidth

6.1.1 Test Setup

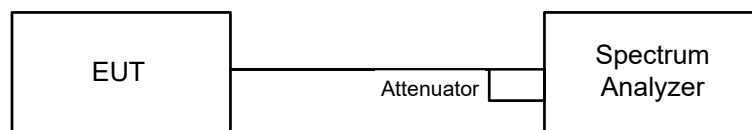

6.1.2 Test Procedure

- Set RBW = approximately 1% of the emission bandwidth.
- Set the VBW > RBW.
- Detector = Peak.
- Trace mode = max hold.
- Measure the maximum width of the emission that is 26 dB down from the peak of the emission. Compare this with the RBW setting of the analyzer. Readjust RBW and repeat measurement as needed until the RBW/EBW ratio is approximately 1%.

6.2 RF Output Power

6.2.1 Test Setup

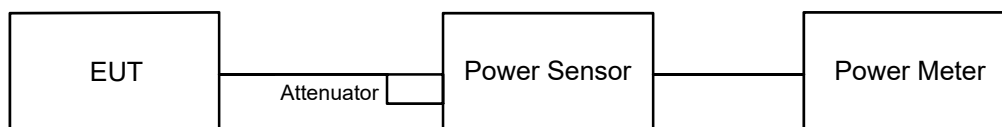

For channel straddling:

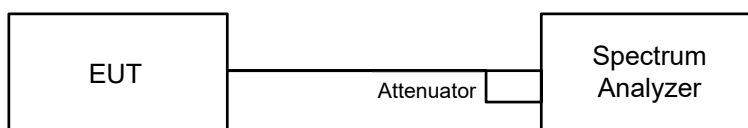

6.2.2 Test Procedure

Method PM is used to perform output power measurement, trigger and gating function of wide band power meter is enabled to measure max output power of TX on burst and set the detector to average. Duty factor is not added to measured value.

For channel straddling:

Method SA-1

- Set span to encompass the entire emission bandwidth (EBW) of the signal.
- Set RBW = 1 MHz, Set VBW \geq 3 MHz, Detector = RMS
- Sweep points \geq $[2 \times \text{span} / \text{RBW}]$. (This gives bin-to-bin spacing \leq RBW / 2, so that narrowband signals are not lost between frequency bins.)
- Sweep time = auto, trigger set to "free run".
- Trace average at least 100 traces in power averaging mode.
- Record the max value

Note: When measuring straddle channel power, use compute power by integrating the spectrum across the 26 dB EBW or 99% OBW of the signal using the instrument's band power measurement function, with band limits set equal to the EBW or OBW band edges. If the instrument does not have a band power function, then sum the spectrum levels (in power units) at 1 MHz intervals extending across the 26 dB EBW or 99% OBW of the spectrum.

6.3 Power Spectral Density

6.3.1 Test Setup

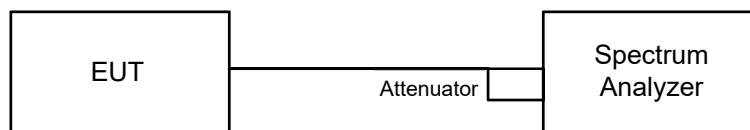

6.3.2 Test Procedure

For specified measurement bandwidth 1 MHz:

Method SA-1

- Set span to encompass the entire emission bandwidth (EBW) of the signal.
- Set RBW = 1 MHz, Set VBW \geq 3 MHz, Detector = RMS
- Sweep points $\geq [2 \times \text{span} / \text{RBW}]$. (This gives bin-to-bin spacing $\leq \text{RBW} / 2$, so that narrowband signals are not lost between frequency bins.)
- Sweep time = auto, trigger set to "free run".
- Trace average at least 100 traces in power averaging mode.
- Record the max value

For specified measurement bandwidth 500 kHz:

Method SA-1

- Set span to encompass the entire emission bandwidth (EBW) of the signal.
- Set RBW = 300 kHz, Set VBW \geq 1 MHz, Detector = RMS
- Scale the observed power level to an equivalent value in 500 kHz by adjusting (increasing) the measured power by a bandwidth correction factor (BWCF) where $\text{BWCF} = 10\log(500 \text{ kHz}/300 \text{ kHz})$
- Sweep points $\geq [2 \times \text{span} / \text{RBW}]$. (This gives bin-to-bin spacing $\leq \text{RBW} / 2$, so that narrowband signals are not lost between frequency bins.)
- Sweep time = auto, trigger set to "free run".
- Trace average at least 100 traces in power averaging mode.
- Record the max value

6.4 6 dB Bandwidth

6.4.1 Test Setup

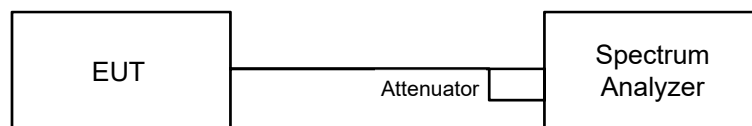

6.4.2 Test Procedure

- Set resolution bandwidth (RBW) = 100 kHz.
- Set the video bandwidth (VBW) $\geq 3 \times \text{RBW}$, Detector = Peak.
- Trace mode = max hold.
- Sweep = auto couple.
- Measure the maximum width of the emission that is constrained by the frequencies associated with the two amplitude points (upper and lower) that are attenuated by 6 dB relative to the maximum level measured in the fundamental emission.

6.5 Occupied Bandwidth

6.5.1 Test Setup

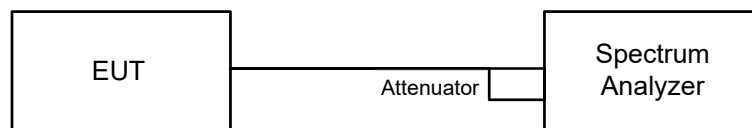

6.5.2 Test Procedure

The transmitter output was connected to the spectrum analyzer through an attenuator. The bandwidth of the fundamental frequency was measured by spectrum analyzer with resolution bandwidth in the range of 1% to 5% of the anticipated emission bandwidth, and a video bandwidth at least 3x the resolution bandwidth and set the detector to Sampling. The width of a frequency band such that, below the lower and above the upper frequency limits, the mean powers emitted are each equal to a specified percentage 0.5% of the total mean power of a given emission.

6.6 Frequency Stability

6.6.1 Test Setup

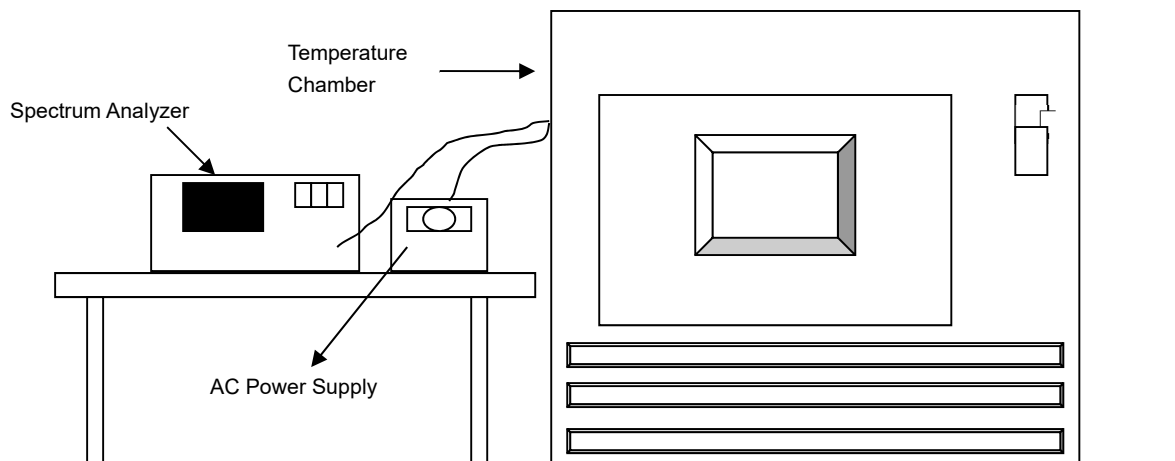

6.6.2 Test Procedure

- The EUT was placed inside the environmental test chamber and powered by nominal AC voltage.
- Turn the EUT on and couple its output to a spectrum analyzer.
- Turn the EUT off and set the chamber to the highest temperature specified.
- Allow sufficient time (approximately 30 min) for the temperature of the chamber to stabilize, turn the EUT on and measure the operating frequency after 2, 5, and 10 Minutes.
- Repeat step (d) with the temperature chamber set to the next desired temperature until measurements down to the lowest specified temperature have been completed.
- The test chamber was allowed to stabilize at +20 degree C for a minimum of 30 Minutes. The supply voltage was then adjusted on the EUT from 85% to 115% and the frequency record.

6.7 AC Power Conducted Emissions

6.7.1 Test Setup

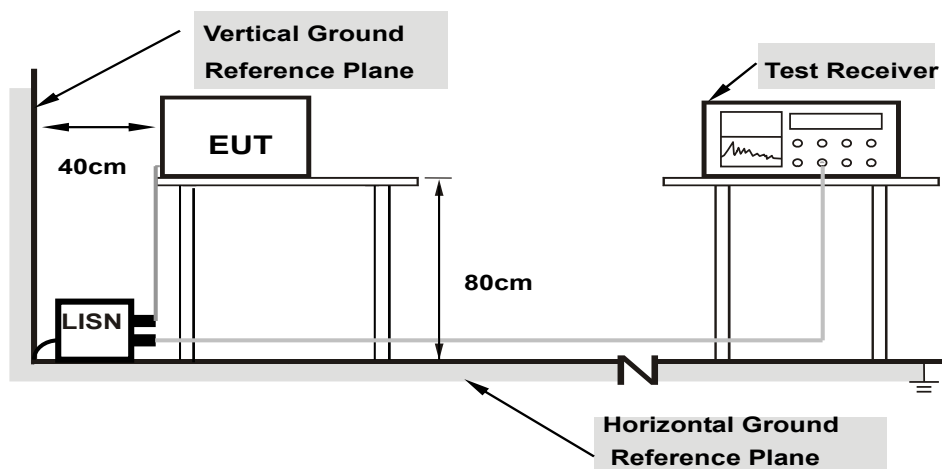

Note: 1.Support units were connected to second LISN.

For the actual test configuration, please refer to the attached file (Test Setup Photo).

6.7.2 Test Procedure

- a. The EUT was placed on a 0.8 meter to the top of table and placed 0.4 meters from the conducting wall of the shielded room with EUT being connected to the power mains through a line impedance stabilization network (LISN). Other support units were connected to the power mains through another LISN. The two LISNs provide 50 ohm/ 50 uH of coupling impedance for the measuring instrument.
- b. Both lines of the power mains connected to the EUT were checked for maximum conducted interference.
- c. The frequency range from 150 kHz to 30 MHz was searched. Emission levels under (Limit – 20 dB) was not recorded.

Note: The resolution bandwidth and video bandwidth of test receiver is 9 kHz for quasi-peak detection (QP) and average detection (AV) at frequency 0.15 MHz-30 MHz.

6.8 Unwanted Emissions below 1 GHz

6.8.1 Test Setup

For Radiated emission below 30 MHz

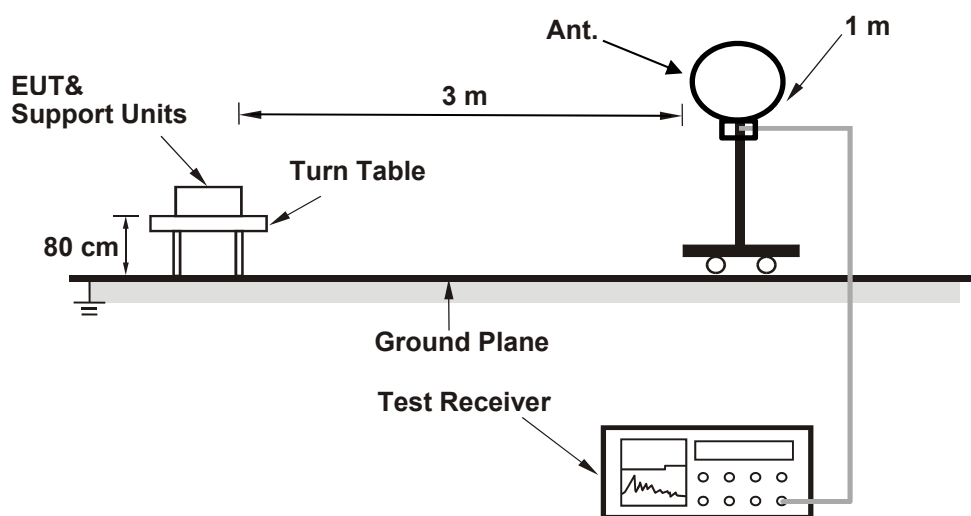

For Radiated emission above 30 MHz

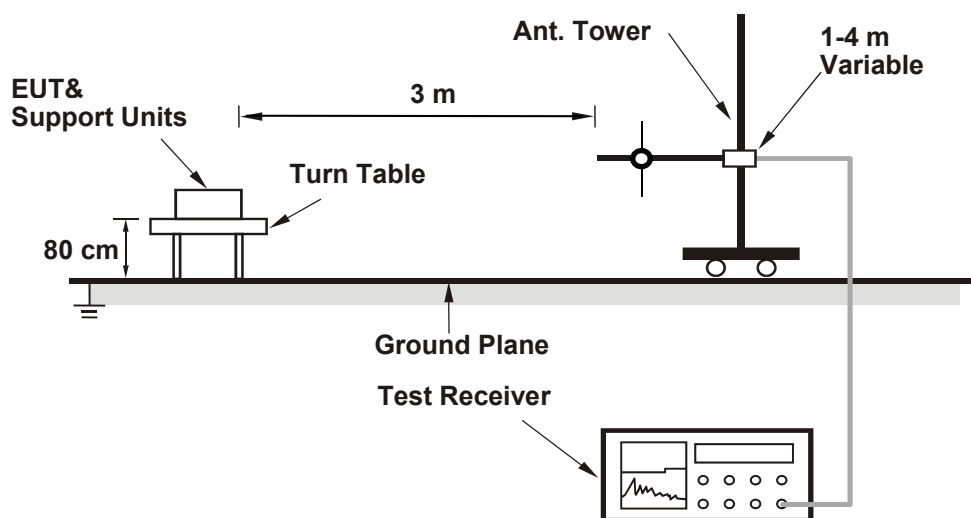

For the actual test configuration, please refer to the attached file (Test Setup Photo).

6.8.2 Test Procedure

For Radiated emission below 30 MHz

- a. The EUT was placed on the top of a rotating table 0.8 meters above the ground at 3 meter chamber room for test. The table was rotated 360 degrees to determine the position of the highest radiation.
- b. The EUT was set 3 meters away from the interference-receiving antenna, which was mounted on the top of a variable-height antenna tower.
- c. Parallel, perpendicular, and ground-parallel orientations of the antenna are set to make the measurement.
- d. For each suspected emission, the EUT was arranged to its worst case and the rotatable table was turned from 0 degrees to 360 degrees to find the maximum reading.
- e. The test-receiver system was set to Quasi-Peak Detect Function and Specified Bandwidth with Maximum Hold Mode, except for the frequency band (9 kHz to 90 kHz and 110 kHz to 490 kHz) set to average detect function and peak detect function.

Notes:

1. The resolution bandwidth and video bandwidth of test receiver/spectrum analyzer is 200 Hz at frequency below 150 kHz.
2. The resolution bandwidth and video bandwidth of test receiver/spectrum analyzer is 9 kHz or 10 kHz at frequency (150 kHz to 30 MHz).
3. All modes of operation were investigated and the worst-case emissions are reported.

For Radiated emission above 30 MHz

- a. The EUT was placed on the top of a rotating table 0.8 meters above the ground at 3 meter chamber room for test. The table was rotated 360 degrees to determine the position of the highest radiation.
- b. The EUT was set 3 meters away from the interference-receiving antenna, which was mounted on the top of a variable-height antenna tower.
- c. The height of antenna is varied from one meter to four meters above the ground to determine the maximum value of the field strength. Both horizontal and vertical polarizations of the antenna are set to make the measurement.
- d. For each suspected emission, the EUT was arranged to its worst case and then the antenna was tuned to heights from 1 meter to 4 meters and the rotatable table was turned from 0 degrees to 360 degrees to find the maximum reading.
- e. The test-receiver system was set to quasi-peak detect function and specified bandwidth with maximum hold mode when the test frequency is below 1 GHz.

Notes:

1. The resolution bandwidth and video bandwidth of test receiver/spectrum analyzer is 120 kHz for Quasi-peak detection (QP) at frequency below 1 GHz.
2. All modes of operation were investigated and the worst-case emissions are reported.

6.9 Unwanted Emissions above 1 GHz

6.9.1 Test Setup

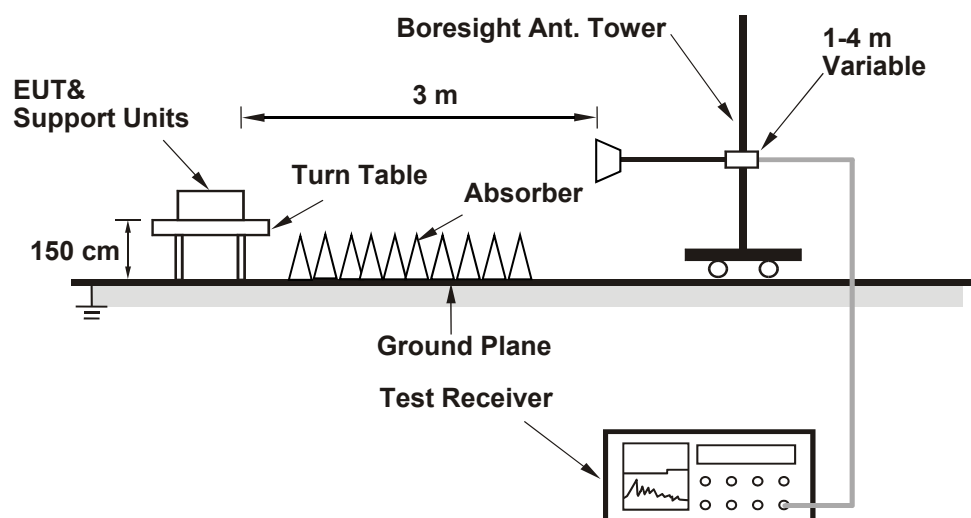

For the actual test configuration, please refer to the attached file (Test Setup Photo).

6.9.2 Test Procedure

- The EUT was placed on the top of a rotating table 1.5 meters above the ground at 3 meter chamber room for test. The table was rotated 360 degrees to determine the position of the highest radiation.
- The EUT was set 3 meters away from the interference-receiving antenna, which was mounted on the top of a variable-height antenna tower.
- The height of antenna is varied from one meter to four meters above the ground to determine the maximum value of the field strength. Both horizontal and vertical polarizations of the antenna are set to make the measurement.
- For each suspected emission, the EUT was arranged to its worst case and then the antenna was tuned to heights from 1 meter to 4 meters and the rotatable table was turned from 0 degrees to 360 degrees to find the maximum reading.
- The test-receiver system was set to peak and average detects function and specified bandwidth with maximum hold mode when the test frequency is above 1 GHz. If the peak reading value also meets average limit, measurement with the average detector is unnecessary.

Notes:

- The resolution bandwidth of test receiver/spectrum analyzer is 1 MHz and the video bandwidth is 3 MHz for Peak detection (PK) and Average detection (AV) at frequency above 1 GHz.
- For fundamental and harmonic signal measurement, the resolution bandwidth of test receiver/spectrum analyzer is 1 MHz and the video bandwidth is $\geq 1/T$ (Duty cycle $< 98\%$) or 10 Hz (Duty cycle $\geq 98\%$) for Average detection (AV) at frequency above 1 GHz.
- All modes of operation were investigated and the worst-case emissions are reported.

7 Test Results of Test Item

7.1 26 dB Bandwidth

Input Power:	120 Vac, 60 Hz	Environmental Conditions:	25°C, 60% RH	Tested By:	Gary Lin / Frank Liu
--------------	----------------	---------------------------	--------------	------------	----------------------

802.11a

Channel	Frequency (MHz)	26 dB Bandwidth (MHz)			
		Chain 0	Chain 1	Chain 2	Chain 3
52	5260	23.03	23.81	24.31	24.38
60	5300	24.10	23.24	24.23	24.56
64	5320	26.74	26.88	22.85	23.89
100	5500	25.39	23.63	23.83	23.26
116	5580	24.99	22.85	22.96	22.62
140	5700	21.73	21.63	21.63	21.81
144 (U-NII-2C)	5720	16.25	16.32	16.11	16.12
144 (U-NII-3)	5720	6.20	6.27	6.33	6.12

Determined Output Power Limit			
Channel Number	Freq.(MHz)	Min. B(MHz)	Determined Conducted Power Limit (dBm)
52	5260	23.03	24.62 > 24
60	5300	23.24	24.66 > 24
64	5320	22.85	24.58 > 24
100	5500	23.26	24.66 > 24
116	5580	22.62	24.54 > 24
140	5700	21.63	24.35 > 24
144 (U-NII-2C)	5720	16.11	23.07 < 24

Note: For U-NII-2A, U-NII-2C Band output power limitation is determined based on 26dBc bandwidth.

802.11be (EHT20)

Channel	Frequency (MHz)	26 dB Bandwidth (MHz)			
		Chain 0	Chain 1	Chain 2	Chain 3
52	5260	27.61	27.42	28.49	26.64
60	5300	25.96	24.48	26.40	31.06
64	5320	28.01	28.49	28.57	22.66
100	5500	26.77	24.13	24.13	24.67
116	5580	24.56	28.82	28.33	22.33
140	5700	21.75	21.82	21.67	21.69
144 (U-NII-2C)	5720	20.50	16.20	17.30	17.73
144 (U-NII-3)	5720	8.03	7.13	6.31	6.25

Determined Output Power Limit			
Channel Number	Freq.(MHz)	Min. B(MHz)	Determined Conducted Power Limit (dBm)
52	5260	26.64	25.25 > 24
60	5300	24.48	24.88 > 24
64	5320	22.66	24.55 > 24
100	5500	24.13	24.82 > 24
116	5580	22.33	24.48 > 24
140	5700	21.67	24.35 > 24
144 (U-NII-2C)	5720	16.20	23.09 < 24

Note: For U-NII-2A, U-NII-2C Band output power limitation is determined based on 26dBc bandwidth.

802.11be (EHT40)

Channel	Frequency (MHz)	26 dB Bandwidth (MHz)			
		Chain 0	Chain 1	Chain 2	Chain 3
54	5270	44.05	42.04	51.03	43.32
62	5310	50.38	44.78	45.77	43.29
102	5510	44.62	43.74	47.34	52.01
110	5550	44.87	42.66	44.11	42.87
134	5670	43.92	44.18	43.70	42.70
142 (U-NII-2C)	5710	36.28	36.35	37.91	36.46
142 (U-NII-3)	5710	5.75	7.65	11.34	6.38

Determined Output Power Limit			
Channel Number	Freq.(MHz)	Min. B(MHz)	Determined Conducted Power Limit (dBm)
54	5270	42.04	27.23 > 24
62	5310	43.29	27.36 > 24
102	5510	43.74	27.4 > 24
110	5550	42.66	27.3 > 24
134	5670	42.70	27.3 > 24
142 (U-NII-2C)	5710	36.28	26.59 > 24

Note: For U-NII-2A, U-NII-2C Band output power limitation is determined based on 26dBc bandwidth.

802.11be (EHT80)

Channel	Frequency (MHz)	26 dB Bandwidth (MHz)			
		Chain 0	Chain 1	Chain 2	Chain 3
58	5290	86.43	83.85	91.70	89.52
106	5530	84.18	86.32	85.11	86.00
122	5610	86.30	83.80	84.36	84.71
138 (U-NII-2C)	5690	76.80	83.51	76.56	77.11
138 (U-NII-3)	5690	6.38	6.65	6.57	6.55

Determined Output Power Limit			
Channel Number	Freq.(MHz)	Min. B(MHz)	Determined Conducted Power Limit (dBm)
58	5290	83.85	30.23 > 24
106	5530	84.18	30.25 > 24
122	5610	83.80	30.23 > 24
138 (U-NII-2C)	5690	76.56	29.84 > 24

Note: For U-NII-2A, U-NII-2C Band output power limitation is determined based on 26dBc bandwidth.

802.11be (EHT160)

Channel	Frequency (MHz)	26 dB Bandwidth (MHz)			
		Chain 0	Chain 1	Chain 2	Chain 3
50 (U-NII-1)	5250	82.45	82.62	82.89	82.48
50 (U-NII-2A)	5250	82.93	82.49	82.86	82.61
114	5570	165.16	165.59	165.47	165.49

Determined Output Power Limit			
Channel Number	Freq.(MHz)	Min. B(MHz)	Determined Conducted Power Limit (dBm)
50 (U-NII-2A)	5250	82.49	30.16 > 24
114	5570	165.16	33.17 > 24

Note: For U-NII-2A, U-NII-2C Band output power limitation is determined based on 26dBc bandwidth.

Spectrum Plot of Minimum Value

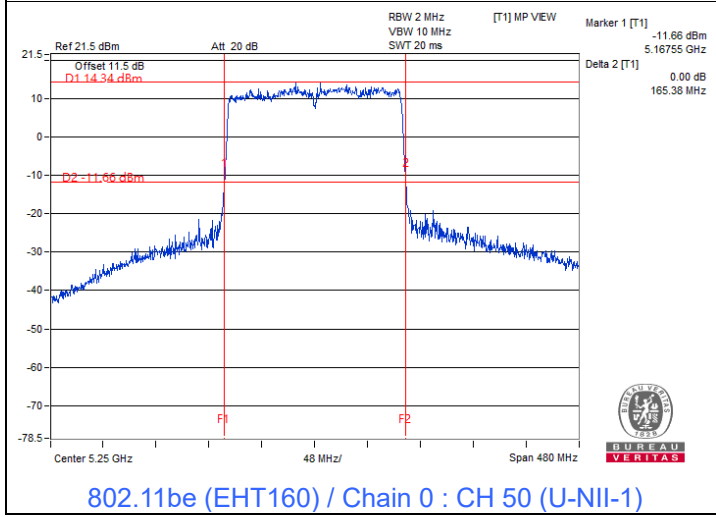
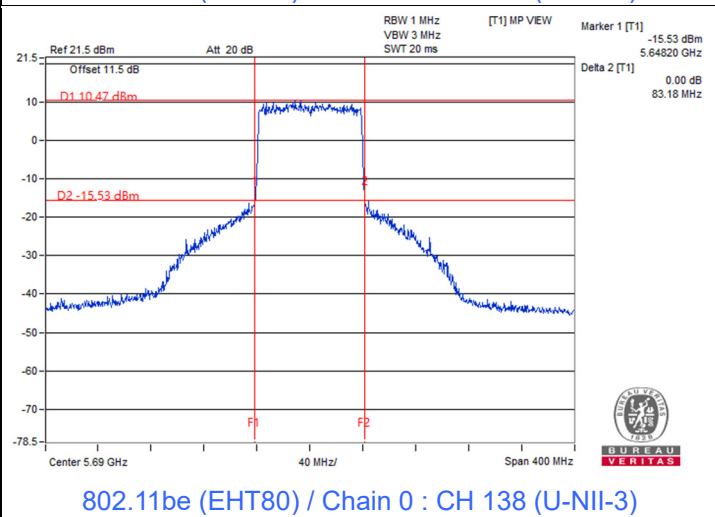
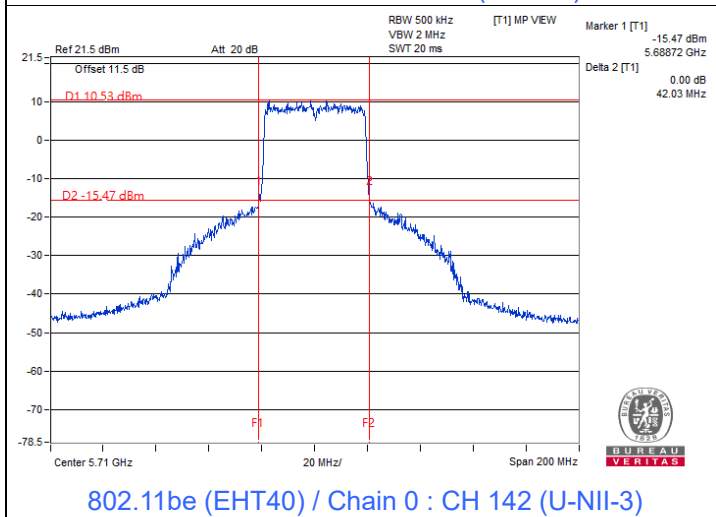
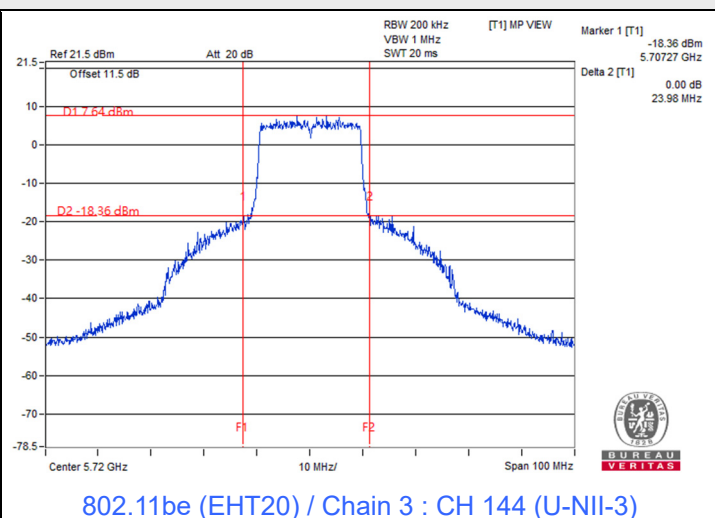
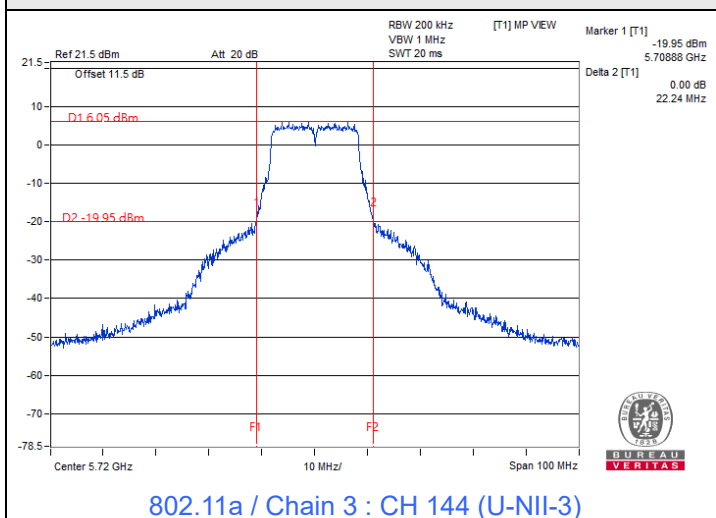

- Notes:
1. For U-NII-2C straddle channel = 5725 MHz - Marker 1
 2. For U-NII-3 straddle channel = Marker 1 + Delta 2 - 5725 MHz
 3. For U-NII-1 straddle channel = 5250 MHz - Marker 1
 4. For U-NII-2A straddle channel = Marker 1 + Delta 2 - 5250 MHz

7.2 RF Output Power

Input Power:	120 Vac, 60 Hz	Environmental Conditions:	25°C, 60% RH	Tested By:	Gary Lin / Frank Liu
--------------	----------------	---------------------------	--------------	------------	----------------------

802.11a CDD

Chan.	Chan. Freq. (MHz)	Average Power (dBm)				Total Power (mW)	Total Power (dBm)	Power Limit (dBm)	Test Result
		Chain 0	Chain 1	Chain 2	Chain 3				
36	5180	22.78	22.86	22.43	22.54	737.325	28.68	30	Pass
40	5200	23.22	23.22	23.10	23.36	840.732	29.25	30	Pass
48	5240	23.21	23.41	22.96	23.28	839.203	29.24	30	Pass
52	5260	17.23	17.64	16.69	17.07	208.520	23.19	24	Pass
60	5300	17.03	17.53	17.02	16.82	205.524	23.13	24	Pass
64	5320	16.96	17.44	17.23	16.78	205.609	23.13	24	Pass
100	5500	17.16	17.37	16.93	17.21	208.494	23.19	24	Pass
116	5580	16.67	17.26	16.87	17.51	204.667	23.11	24	Pass
140	5700	17.30	17.25	17.06	17.29	211.187	23.25	24	Pass
*144 (U-NII-2C)	5720	15.51	15.78	15.53	16.01	149.037	21.73	23.07	Pass
*144 (U-NII-3)	5720	9.44	9.63	9.47	9.93	36.665	15.64	30	Pass
149	5745	23.45	23.57	22.95	23.38	863.832	29.36	30	Pass
157	5785	23.11	23.59	23.07	23.17	843.464	29.26	30	Pass
165	5825	23.35	23.26	22.55	23.79	847.327	29.28	30	Pass

Notes:

- * : Test was performed in accordance with measurement follow FCC KDB 789033 UNII test procedure Method SA-1 and use spectrum analyzer test.
- Directional gain is the maximum gain of antennas.
- For U-NII-1, the maximum gain is 3.63 dBi < 6 dBi, so the output power limit shall not be reduced.
- For U-NII-2A, the maximum gain is 3.71 dBi < 6 dBi, so the output power limit shall not be reduced.
- For U-NII-2C, the maximum gain is 4.02 dBi < 6 dBi, so the output power limit shall not be reduced.
- For U-NII-3, the maximum gain is 4.25 dBi < 6 dBi, so the output power limit shall not be reduced.

802.11be (EHT20) CDD

Chan.	Chan. Freq. (MHz)	Average Power (dBm)				Total Power (mW)	Total Power (dBm)	Power Limit (dBm)	Test Result
		Chain 0	Chain 1	Chain 2	Chain 3				
36	5180	22.04	22.07	22.07	22.19	647.662	28.11	30	Pass
40	5200	23.14	23.10	23.23	23.24	831.477	29.20	30	Pass
48	5240	23.09	23.22	22.91	23.40	827.808	29.18	30	Pass
52	5260	17.20	17.55	17.07	17.06	211.115	23.25	24	Pass
60	5300	17.30	17.53	17.06	17.06	211.959	23.26	24	Pass
64	5320	17.16	17.34	17.34	16.89	209.265	23.21	24	Pass
100	5500	17.15	17.34	16.95	17.33	209.701	23.22	24	Pass
116	5580	16.68	17.39	16.98	17.60	208.819	23.20	24	Pass
140	5700	17.24	17.06	17.11	17.13	206.828	23.16	24	Pass
*144 (U-NII-2C)	5720	15.49	15.84	15.39	15.97	147.901	21.70	23.09	Pass
*144 (U-NII-3)	5720	10.42	10.73	10.23	10.93	45.778	16.61	30	Pass
149	5745	23.23	23.39	22.98	23.12	832.377	29.20	30	Pass
157	5785	22.90	23.32	22.90	23.18	812.722	29.10	30	Pass
165	5825	23.42	23.38	22.48	23.68	847.914	29.28	30	Pass

Notes:

1. * : Test was performed in accordance with measurement follow FCC KDB 789033 UNII test procedure Method SA-1 and use spectrum analyzer test.
2. Directional gain is the maximum gain of antennas.
3. For U-NII-1, the maximum gain is 3.63 dBi < 6 dBi, so the output power limit shall not be reduced.
4. For U-NII-2A, the maximum gain is 3.71 dBi < 6 dBi, so the output power limit shall not be reduced.
5. For U-NII-2C, the maximum gain is 4.02 dBi < 6 dBi, so the output power limit shall not be reduced.
6. For U-NII-3, the maximum gain is 4.25 dBi < 6 dBi, so the output power limit shall not be reduced.

802.11be (EHT40) CDD

Chan.	Chan. Freq. (MHz)	Average Power (dBm)				Total Power (mW)	Total Power (dBm)	Power Limit (dBm)	Test Result
		Chain 0	Chain 1	Chain 2	Chain 3				
38	5190	20.59	20.88	20.32	20.58	458.947	26.62	30	Pass
46	5230	23.29	23.50	22.83	23.39	847.316	29.28	30	Pass
54	5270	17.22	17.49	16.86	17.06	208.173	23.18	24	Pass
62	5310	17.25	17.40	17.32	16.83	210.188	23.23	24	Pass
102	5510	17.18	17.30	16.57	17.21	203.939	23.09	24	Pass
110	5550	16.96	17.31	16.61	17.26	202.511	23.06	24	Pass
134	5670	16.72	17.30	17.29	17.05	204.971	23.12	24	Pass
*142 (U-NII-2C)	5710	16.23	16.59	16.15	16.37	172.14	22.36	24	Pass
*142 (U-NII-3)	5710	6.28	6.62	5.92	7.29	18.105	12.58	30	Pass
151	5755	23.20	23.54	23.28	23.35	863.959	29.36	30	Pass
159	5795	23.08	23.48	23.34	23.37	859.124	29.34	30	Pass

Notes:

- * : Test was performed in accordance with measurement follow FCC KDB 789033 UNII test procedure Method SA-1 and use spectrum analyzer test.
- Directional gain is the maximum gain of antennas.
- For U-NII-1, the maximum gain is 3.63 dBi < 6 dBi, so the output power limit shall not be reduced.
- For U-NII-2A, the maximum gain is 3.71 dBi < 6 dBi, so the output power limit shall not be reduced.
- For U-NII-2C, the maximum gain is 4.02 dBi < 6 dBi, so the output power limit shall not be reduced.
- For U-NII-3, the maximum gain is 4.25 dBi < 6 dBi, so the output power limit shall not be reduced.

802.11be (EHT80) CDD

Chan.	Chan. Freq. (MHz)	Average Power (dBm)				Total Power (mW)	Total Power (dBm)	Power Limit (dBm)	Test Result
		Chain 0	Chain 1	Chain 2	Chain 3				
42	5210	20.46	20.67	20.50	20.61	455.136	26.58	30	Pass
58	5290	17.18	17.50	17.21	17.00	211.194	23.25	24	Pass
106	5530	17.13	17.77	16.80	17.01	209.580	23.21	24	Pass
122	5610	17.20	17.35	16.32	17.48	205.636	23.13	24	Pass
*138 (U-NII-2C)	5690	16.68	16.69	16.46	16.84	185.789	22.69	24	Pass
*138 (U-NII-3)	5690	3.53	3.24	2.44	4.15	8.717	9.40	30	Pass
155	5775	22.25	22.37	22.57	22.54	700.655	28.46	30	Pass

Notes:

- * : Test was performed in accordance with measurement follow FCC KDB 789033 UNII test procedure Method SA-1 and use spectrum analyzer test.
- Directional gain is the maximum gain of antennas.
- For U-NII-1, the maximum gain is 3.63 dBi < 6 dBi, so the output power limit shall not be reduced.
- For U-NII-2A, the maximum gain is 3.71 dBi < 6 dBi, so the output power limit shall not be reduced.
- For U-NII-2C, the maximum gain is 4.02 dBi < 6 dBi, so the output power limit shall not be reduced.
- For U-NII-3, the maximum gain is 4.25 dBi < 6 dBi, so the output power limit shall not be reduced.

802.11be (EHT160) CDD

Chan.	Chan. Freq. (MHz)	Average Power (dBm)				Total Power (mW)	Total Power (dBm)	Power Limit (dBm)	Test Result
		Chain 0	Chain 1	Chain 2	Chain 3				
*50 (U-NII-1)	5250	15.61	15.88	15.99	15.91	153.831	21.87	30	Pass
*50 (U-NII-2A)	5250	16.40	16.10	15.84	15.90	161.665	22.09	24	Pass
114	5570	17.04	17.71	17.00	16.91	208.812	23.20	24	Pass

Notes:

- * : Test was performed in accordance with measurement follow FCC KDB 789033 UNII test procedure Method SA-1 and use spectrum analyzer test.
- Directional gain is the maximum gain of antennas.
- For U-NII-1, the maximum gain is 3.63 dBi < 6 dBi, so the output power limit shall not be reduced.
- For U-NII-2A, the maximum gain is 3.71 dBi < 6 dBi, so the output power limit shall not be reduced.
- For U-NII-2C, the maximum gain is 4.02 dBi < 6 dBi, so the output power limit shall not be reduced.

802.11be (EHT20) Beamforming

Chan.	Chan. Freq. (MHz)	Average Power (dBm)				Total Power (mW)	Total Power (dBm)	Power Limit (dBm)	Test Result
		Chain 0	Chain 1	Chain 2	Chain 3				
36	5180	22.04	22.07	22.07	22.19	647.662	28.11	29.95	Pass
40	5200	23.14	23.10	23.23	23.24	831.477	29.20	29.95	Pass
48	5240	23.09	23.22	22.91	23.40	827.808	29.18	29.95	Pass
52	5260	17.20	17.55	17.07	17.06	211.115	23.25	23.94	Pass
60	5300	17.30	17.53	17.06	17.06	211.959	23.26	23.94	Pass
64	5320	17.16	17.34	17.34	16.89	209.265	23.21	23.94	Pass
100	5500	17.15	17.34	16.95	17.33	209.701	23.22	23.79	Pass
116	5580	16.68	17.39	16.98	17.60	208.819	23.20	23.79	Pass
140	5700	17.24	17.06	17.11	17.13	206.828	23.16	23.79	Pass
*144 (U-NII-2C)	5720	15.49	15.84	15.39	15.97	147.901	21.70	22.88	Pass
*144 (U-NII-3)	5720	10.42	10.73	10.23	10.93	45.778	16.61	29.67	Pass
149	5745	23.23	23.39	22.98	23.12	832.377	29.20	29.67	Pass
157	5785	22.90	23.32	22.90	23.18	812.722	29.10	29.67	Pass
165	5825	23.42	23.38	22.48	23.68	847.914	29.28	29.67	Pass

Notes:

- * : Test was performed in accordance with measurement follow FCC KDB 789033 UNII test procedure Method SA-1 and use spectrum analyzer test.
- Directional gain is the measured value according to KDB 662911 D03 Method of MIMO Antenna Gain Measurement.
- For U-NII-1, the directional gain is 6.05 dBi > 6 dBi, so the output power limit shall be reduced to 30-(6.05-6) = 29.95 dBm.
- For U-NII-2A, the directional gain is 6.06 dBi > 6 dBi, so the output power limit shall be reduced to [Determined Conducted Power Limit-(6.06-6)].
- For U-NII-2C, the directional gain is 6.21 dBi > 6 dBi, so the output power limit shall be reduced to [Determined Conducted Power Limit-(6.21-6)].
- For U-NII-3, the directional gain is 6.33 dBi > 6 dBi, so the output power limit shall be reduced to 30-(6.33-6) = 29.67 dBm.

802.11be (EHT40) Beamforming

Chan.	Chan. Freq. (MHz)	Average Power (dBm)				Total Power (mW)	Total Power (dBm)	Power Limit (dBm)	Test Result
		Chain 0	Chain 1	Chain 2	Chain 3				
38	5190	20.59	20.88	20.32	20.58	458.947	26.62	29.95	Pass
46	5230	23.29	23.50	22.83	23.39	847.316	29.28	29.95	Pass
54	5270	17.22	17.49	16.86	17.06	208.173	23.18	23.94	Pass
62	5310	17.25	17.40	17.32	16.83	210.188	23.23	23.94	Pass
102	5510	17.18	17.30	16.57	17.21	203.939	23.10	23.79	Pass
110	5550	16.96	17.31	16.61	17.26	202.511	23.06	23.79	Pass
134	5670	16.72	17.30	17.29	17.05	204.971	23.12	23.79	Pass
*142 (U-NII-2C)	5710	16.23	16.59	16.15	16.37	172.14	22.36	23.79	Pass
*142 (U-NII-3)	5710	6.28	6.62	5.92	7.29	18.105	12.58	29.67	Pass
151	5755	23.20	23.54	23.28	23.35	863.959	29.36	29.67	Pass
159	5795	23.08	23.48	23.34	23.37	859.124	29.34	29.67	Pass

Notes:

- * : Test was performed in accordance with measurement follow FCC KDB 789033 UNII test procedure Method SA-1 and use spectrum analyzer test.
- Directional gain is the measured value according to KDB 662911 D03 Method of MIMO Antenna Gain Measurement.
- For U-NII-1, the directional gain is 6.05 dBi > 6 dBi, so the output power limit shall be reduced to $30-(6.05-6) = 29.95$ dBm.
- For U-NII-2A, the directional gain is 6.06 dBi > 6 dBi, so the output power limit shall be reduced to [Determined Conducted Power Limit-(6.06-6)].
- For U-NII-2C, the directional gain is 6.21 dBi > 6 dBi, so the output power limit shall be reduced to [Determined Conducted Power Limit-(6.21-6)].
- For U-NII-3, the directional gain is 6.33 dBi > 6 dBi, so the output power limit shall be reduced to $30-(6.33-6) = 29.67$ dBm.

802.11be (EHT80) Beamforming

Chan.	Chan. Freq. (MHz)	Average Power (dBm)				Total Power (mW)	Total Power (dBm)	Power Limit (dBm)	Test Result
		Chain 0	Chain 1	Chain 2	Chain 3				
42	5210	20.46	20.67	20.50	20.61	455.136	26.58	29.95	Pass
58	5290	17.18	17.50	17.21	17.00	211.194	23.25	23.94	Pass
106	5530	17.13	17.77	16.80	17.01	209.580	23.21	23.79	Pass
122	5610	17.20	17.35	16.32	17.48	205.636	23.13	23.79	Pass
*138 (U-NII-2C)	5690	16.68	16.69	16.46	16.84	185.789	22.69	23.79	Pass
*138 (U-NII-3)	5690	3.53	3.24	2.44	4.15	8.717	9.40	29.67	Pass
155	5775	22.25	22.37	22.57	22.54	700.655	28.46	29.67	Pass

Notes:

- * : Test was performed in accordance with measurement follow FCC KDB 789033 UNII test procedure Method SA-1 and use spectrum analyzer test.
- Directional gain is the measured value according to KDB 662911 D03 Method of MIMO Antenna Gain Measurement.
- For U-NII-1, the directional gain is 6.05 dBi > 6 dBi, so the output power limit shall be reduced to $30-(6.05-6) = 29.95$ dBm.
- For U-NII-2A, the directional gain is 6.06 dBi > 6 dBi, so the output power limit shall be reduced to [Determined Conducted Power Limit-(6.06-6)].
- For U-NII-2C, the directional gain is 6.21 dBi > 6 dBi, so the output power limit shall be reduced to [Determined Conducted Power Limit-(6.21-6)].
- For U-NII-3, the directional gain is 6.33 dBi > 6 dBi, so the output power limit shall be reduced to $30-(6.33-6) = 29.67$ dBm.

802.11be (EHT160) Beamforming

Chan.	Chan. Freq. (MHz)	Average Power (dBm)				Total Power (mW)	Total Power (dBm)	Power Limit (dBm)	Test Result
		Chain 0	Chain 1	Chain 2	Chain 3				
*50 (U-NII-1)	5250	15.61	15.88	15.99	15.91	153.831	21.87	29.95	Pass
*50 (U-NII-2A)	5250	16.40	16.10	15.84	15.90	161.665	22.09	23.94	Pass
114	5570	17.04	17.71	17.00	16.91	208.812	23.20	23.79	Pass

Notes:

- * : Test was performed in accordance with measurement follow FCC KDB 789033 UNII test procedure Method SA-1 and use spectrum analyzer test.
- Directional gain is the measured value according to KDB 662911 D03 Method of MIMO Antenna Gain Measurement.
- For U-NII-1, the directional gain is 6.05 dBi > 6 dBi, so the output power limit shall be reduced to $30-(6.05-6) = 29.95$ dBm.
- For U-NII-2A, the directional gain is 6.06 dBi > 6 dBi, so the output power limit shall be reduced to [Determined Conducted Power Limit-(6.06-6)].
- For U-NII-2C, the directional gain is 6.21 dBi > 6 dBi, so the output power limit shall be reduced to [Determined Conducted Power Limit-(6.21-6)].



Spectrum Plot for channel straddling

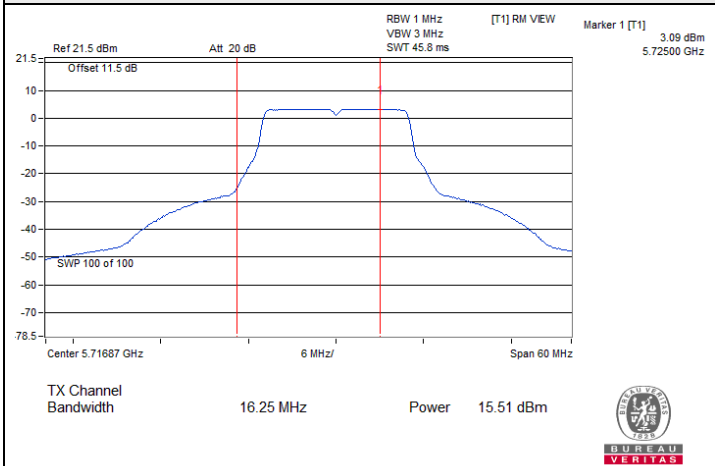

802.11a / Chain 0 : CH 144 (U-NII-2C)

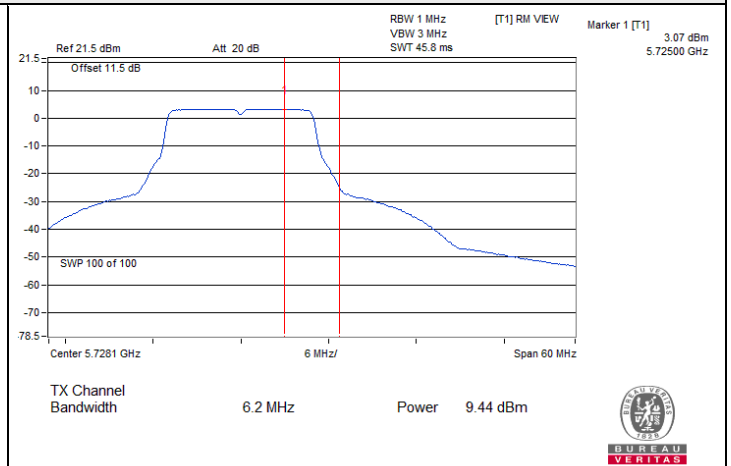

802.11a / Chain 0 : CH 144 (U-NII-3)

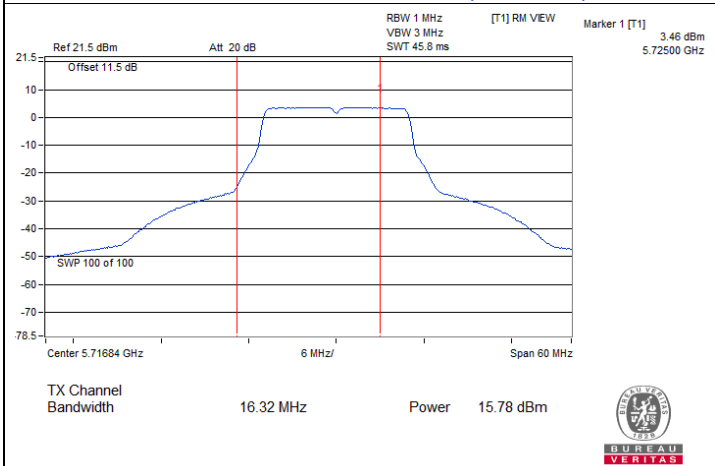

802.11a / Chain 1 : CH 144 (U-NII-2C)

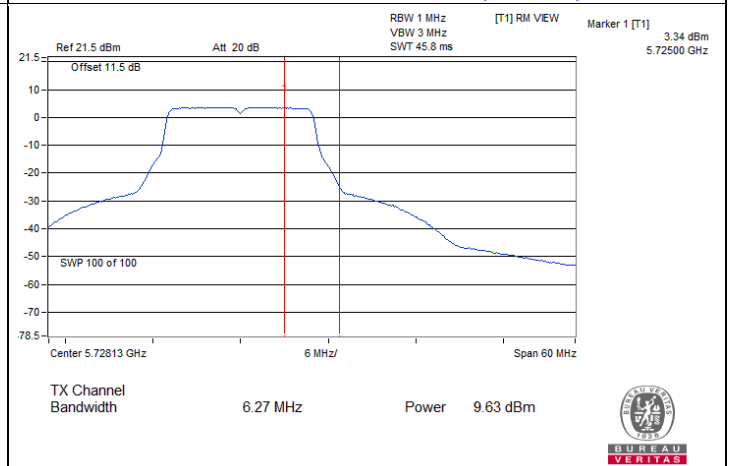

802.11a / Chain 1 : CH 144 (U-NII-3)

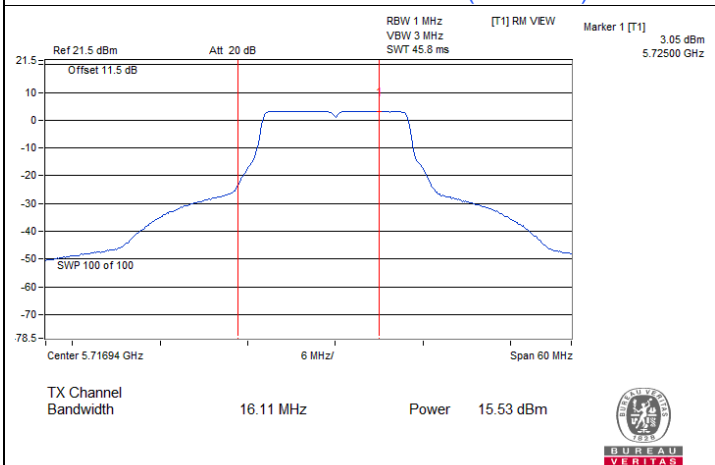

802.11a / Chain 2 : CH 144 (U-NII-2C)

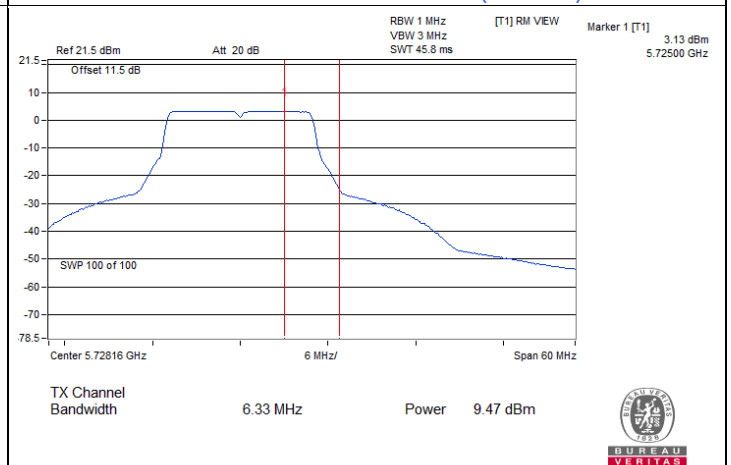

802.11a / Chain 2 : CH 144 (U-NII-3)

Spectrum Plot for channel straddling

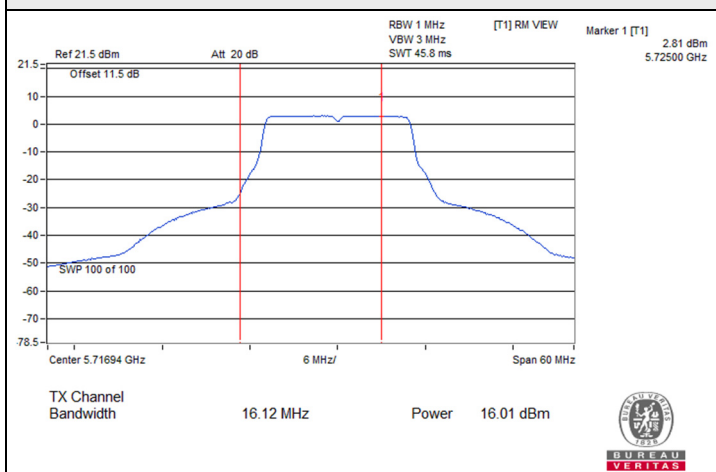

802.11a / Chain 3 : CH 144 (U-NII-2C)

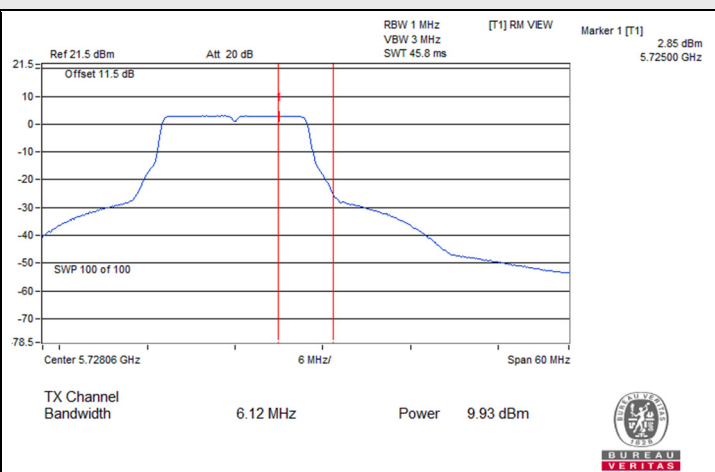

802.11a / Chain 3 : CH 144 (U-NII-3)

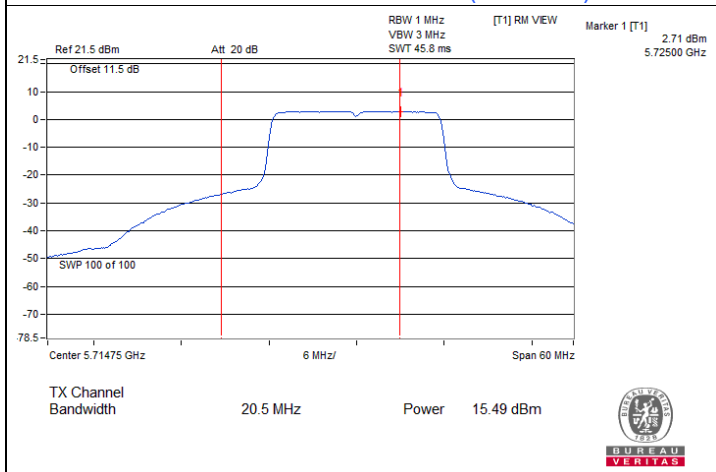

802.11be (EHT20) / Chain 0 : CH 144 (U-NII-2C)

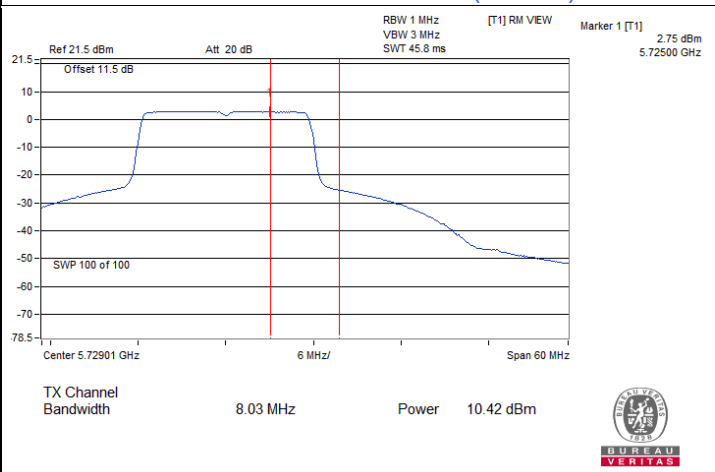

802.11be (EHT20) / Chain 0 : CH 144 (U-NII-3)

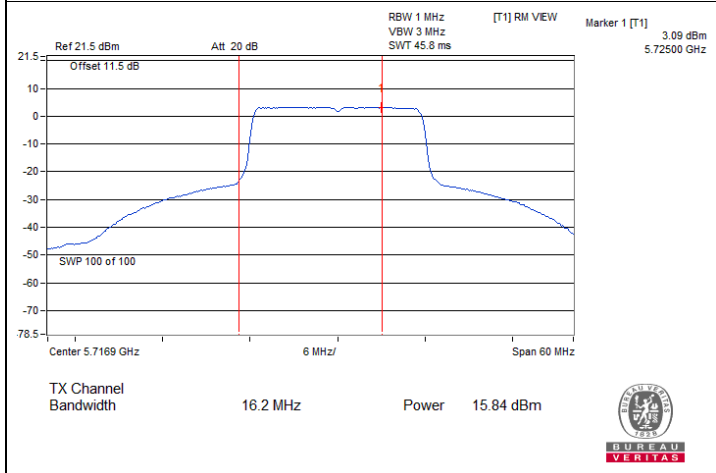

802.11be (EHT20) / Chain 1 : CH 144 (U-NII-2C)

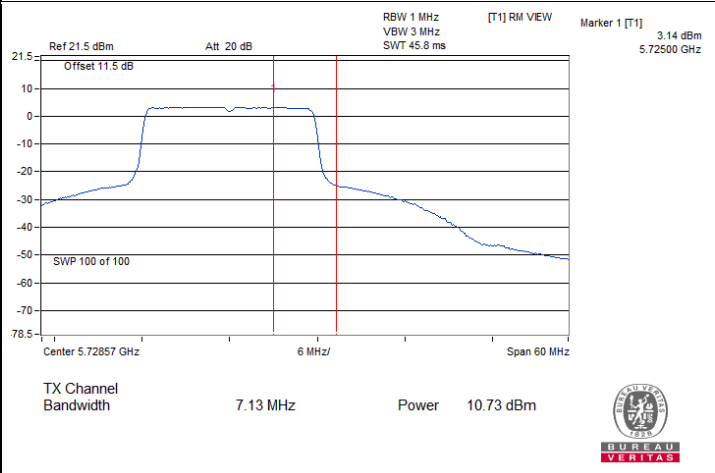

802.11be (EHT20) / Chain 1 : CH 144 (U-NII-3)

Spectrum Plot for channel straddling

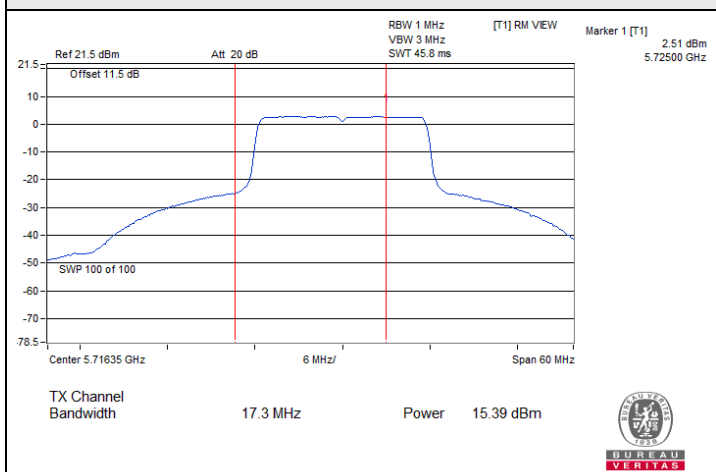

802.11be (EHT20) / Chain 2 : CH 144 (U-NII-2C)

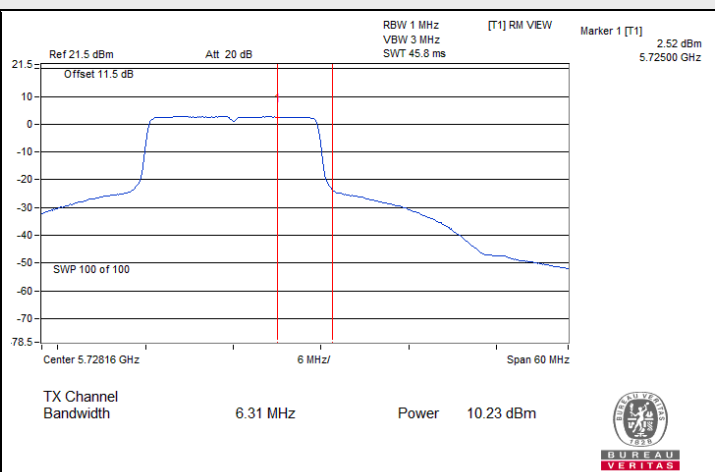

802.11be (EHT20) / Chain 2 : CH 144 (U-NII-3)

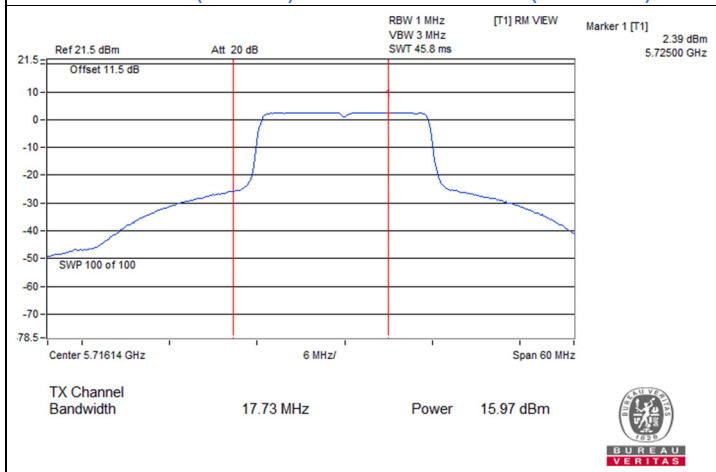

802.11be (EHT20) / Chain 3 : CH 144 (U-NII-2C)

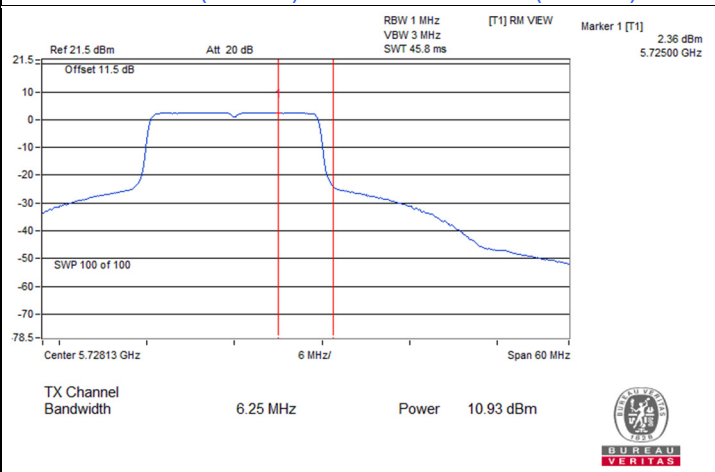

802.11be (EHT20) / Chain 3 : CH 144 (U-NII-3)

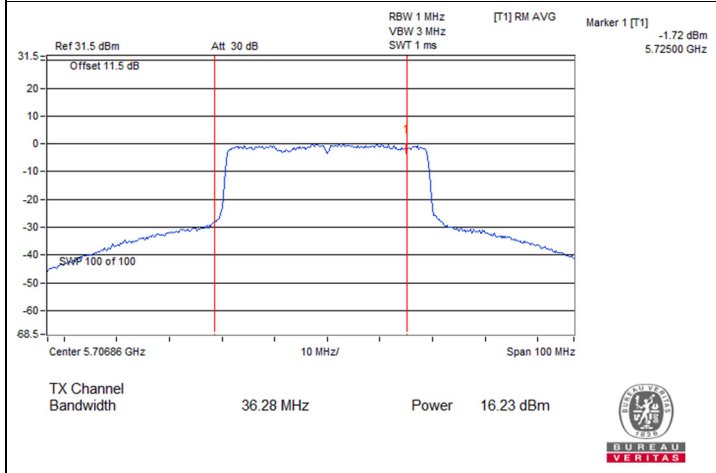

802.11be (EHT40) / Chain 0 : CH 142 (U-NII-2C)

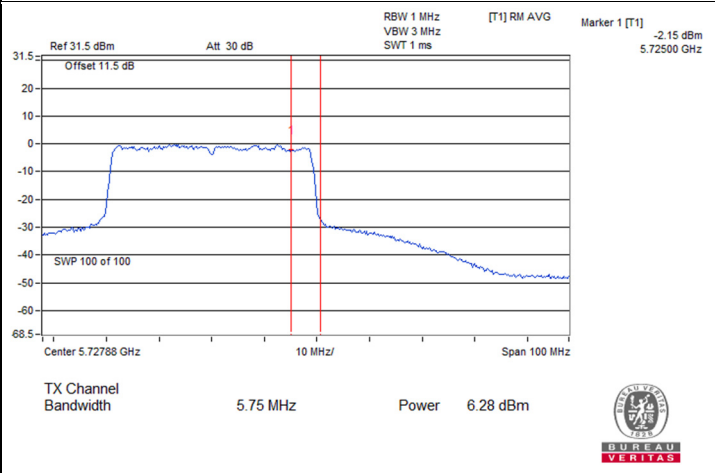

802.11be (EHT40) / Chain 0 : CH 142 (U-NII-3)



Spectrum Plot for channel straddling

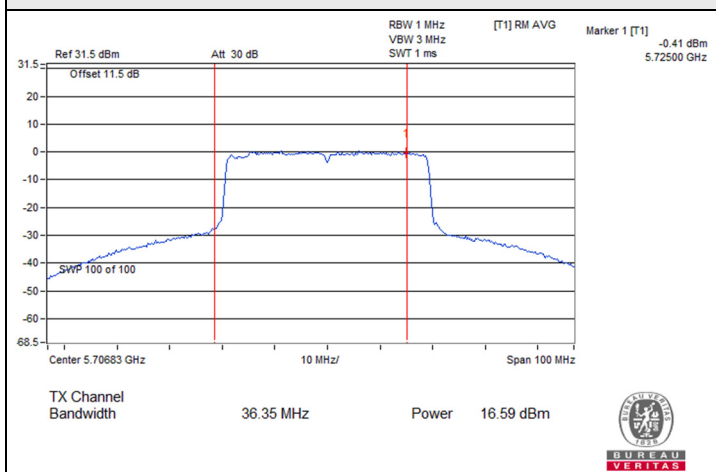

802.11be (EHT40) / Chain 1 : CH 142 (U-NII-2C)

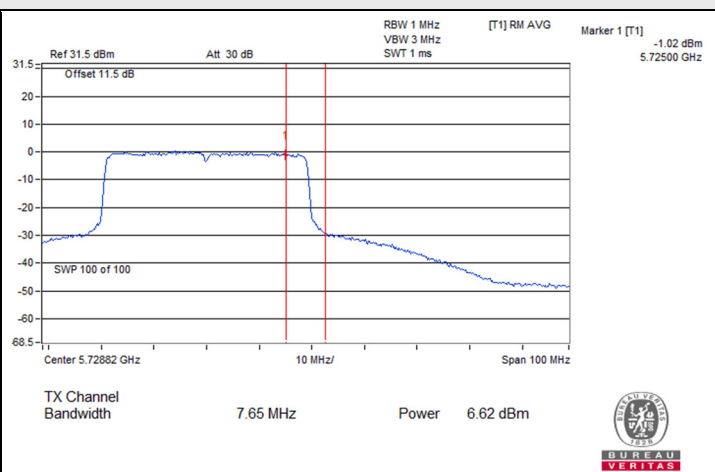

802.11be (EHT40) / Chain 1 : CH 142 (U-NII-3)

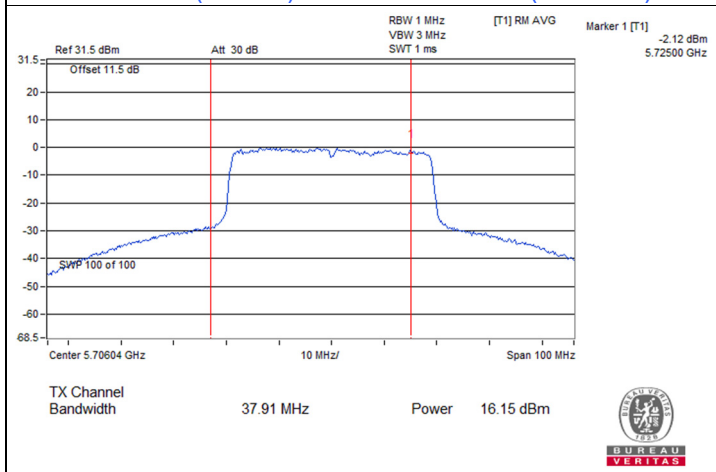

802.11be (EHT40) / Chain 2 : CH 142 (U-NII-2C)

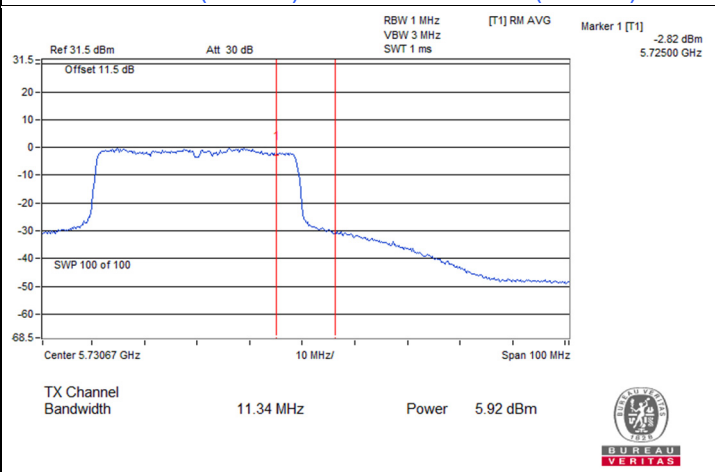

802.11be (EHT40) / Chain 2 : CH 142 (U-NII-3)

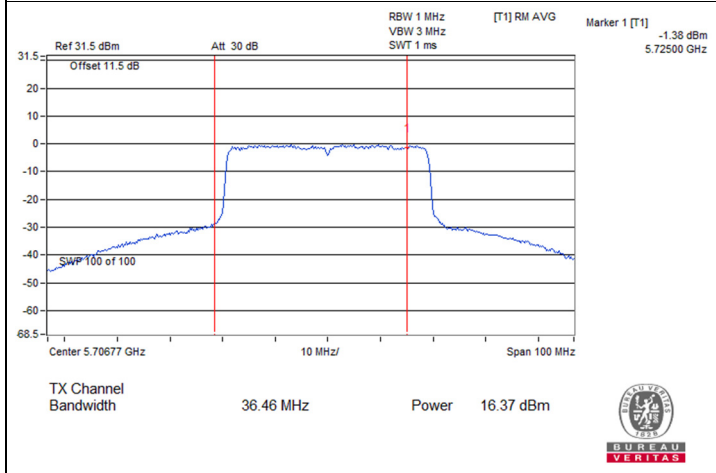

802.11be (EHT40) / Chain 3 : CH 142 (U-NII-2C)

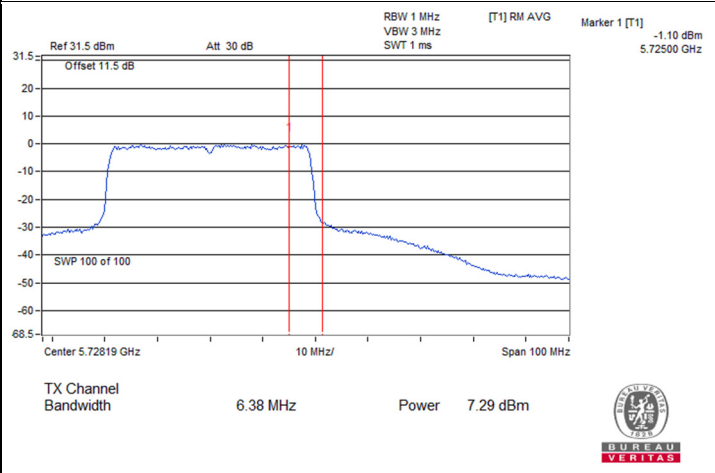

802.11be (EHT40) / Chain 3 : CH 142 (U-NII-3)

Spectrum Plot for channel straddling

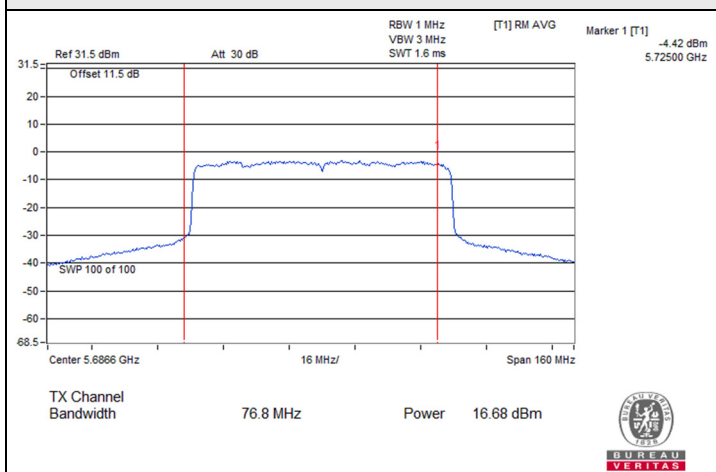

802.11be (EHT80) / Chain 0 : CH 138 (U-NII-2C)

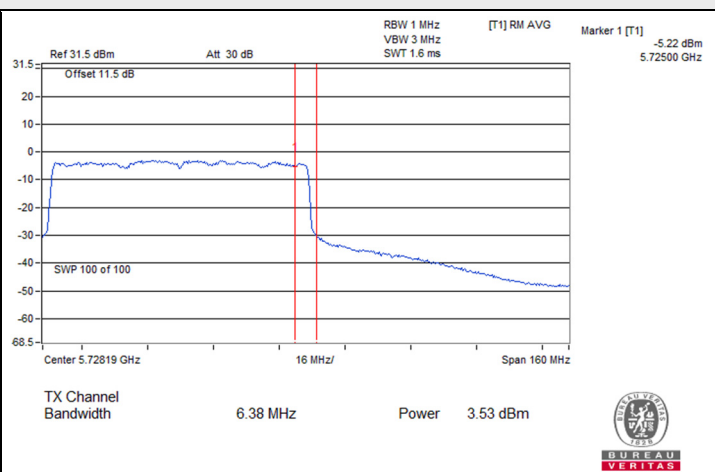

802.11be (EHT80) / Chain 0 : CH 138 (U-NII-3)

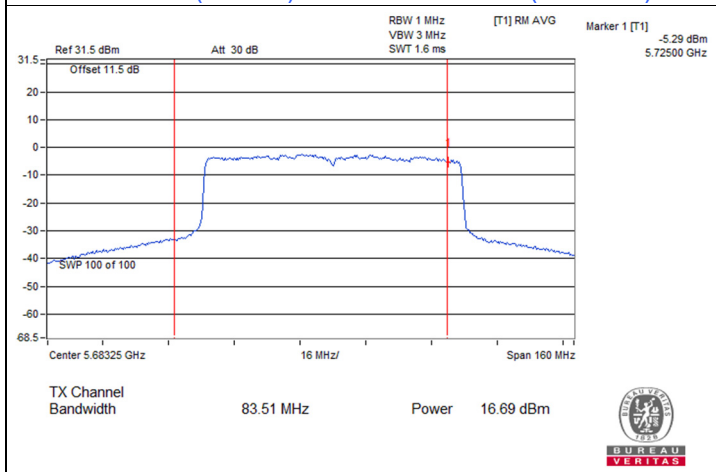

802.11be (EHT80) / Chain 1 : CH 138 (U-NII-2C)

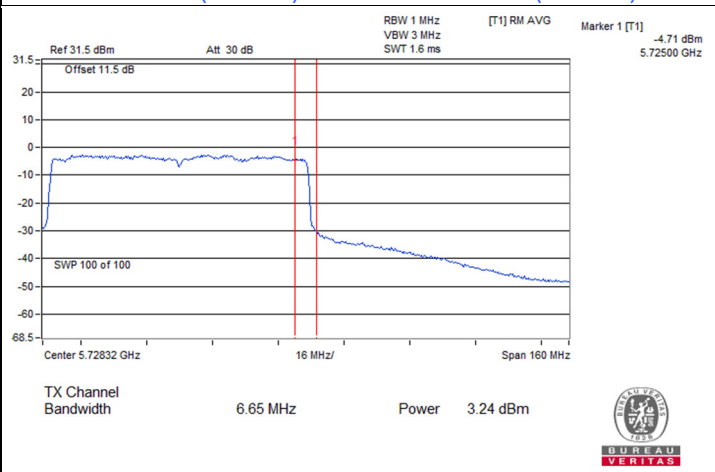

802.11be (EHT80) / Chain 1 : CH 138 (U-NII-3)

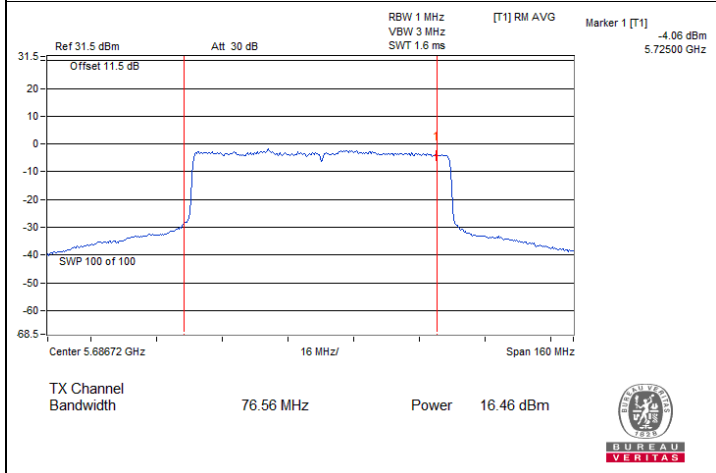

802.11be (EHT80) / Chain 2 : CH 138 (U-NII-2C)

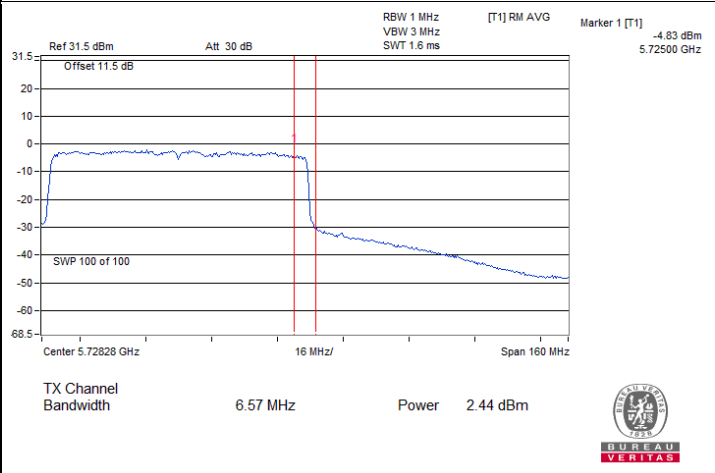

802.11be (EHT80) / Chain 2 : CH 138 (U-NII-3)

Spectrum Plot for channel straddling

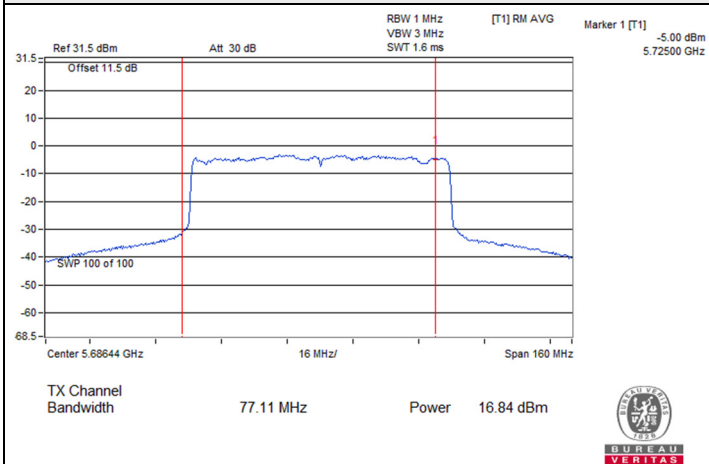

802.11be (EHT80) / Chain 3 : CH 138 (U-NII-2C)

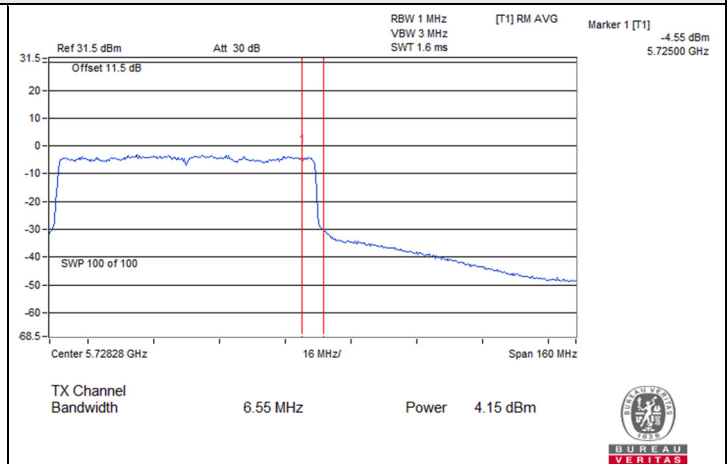

802.11be (EHT80) / Chain 3 : CH 138 (U-NII-3)

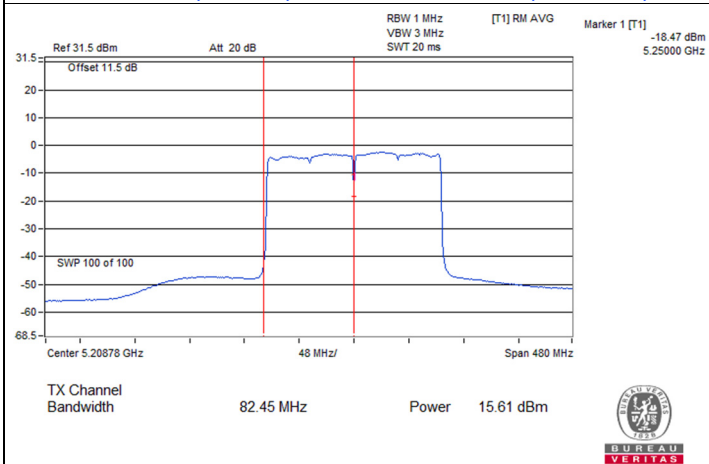

802.11be (EHT160) / Chain 0 : CH 50 (U-NII-1)

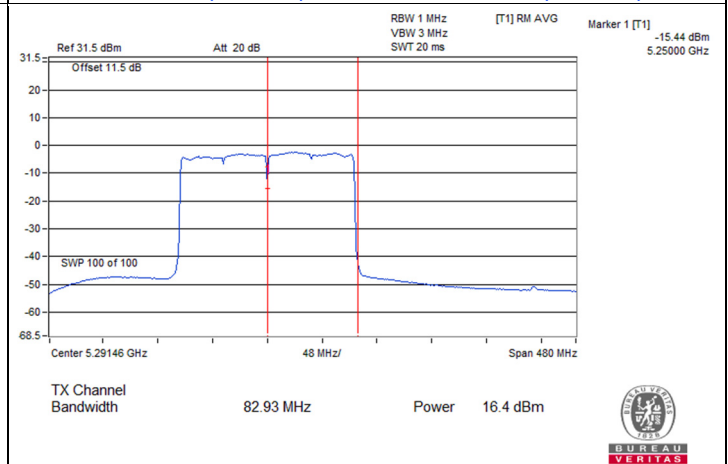

802.11be (EHT160) / Chain 0 : CH 50 (U-NII-2A)

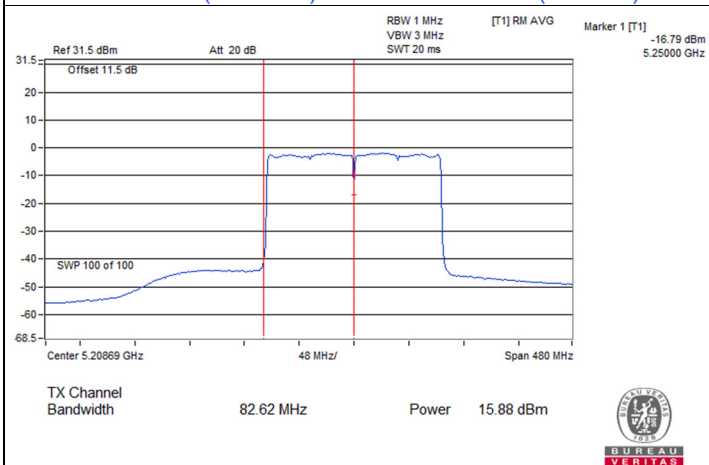

802.11be (EHT160) / Chain 1 : CH 50 (U-NII-1)

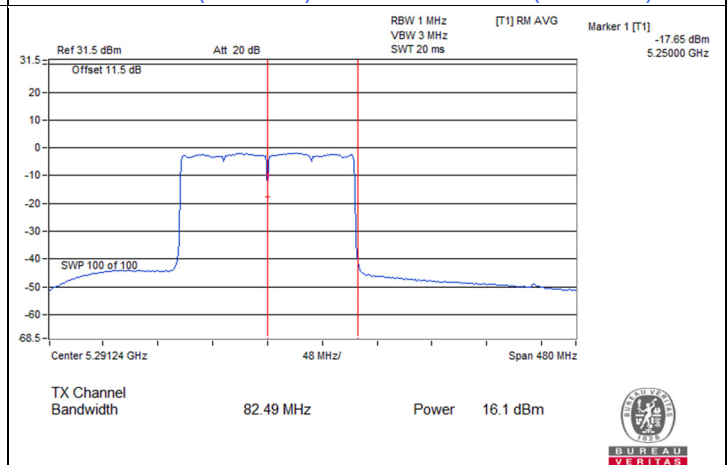

802.11be (EHT160) / Chain 1 : CH 50 (U-NII-2A)



Spectrum Plot for channel straddling

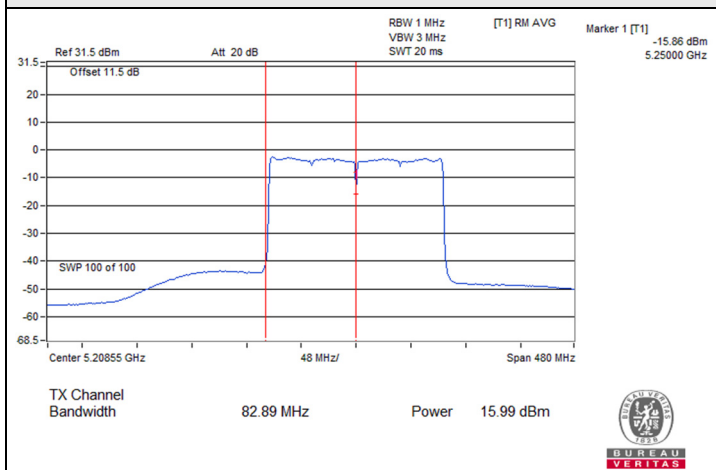

802.11be (EHT160) / Chain 2 : CH 50 (U-NII-1)

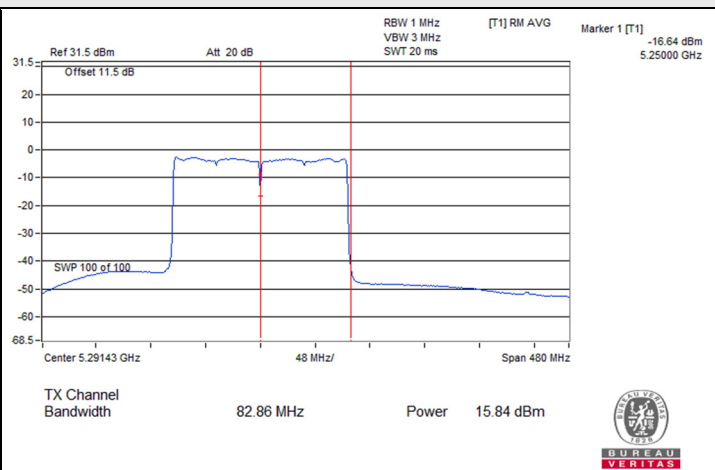

802.11be (EHT160) / Chain 2 : CH 50 (U-NII-2A)

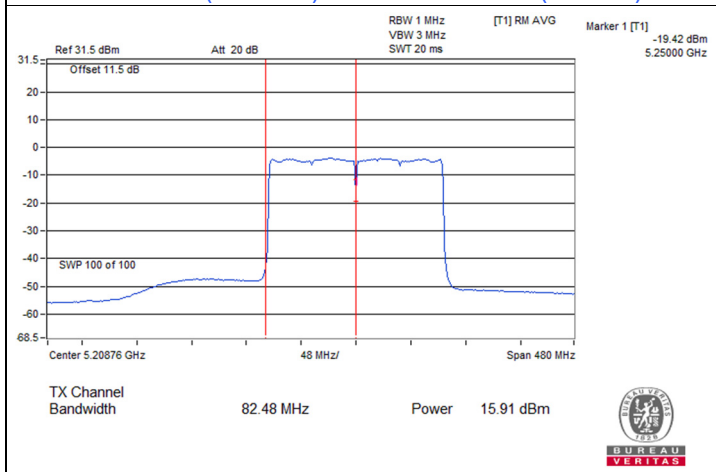

802.11be (EHT160) / Chain 3 : CH 50 (U-NII-1)

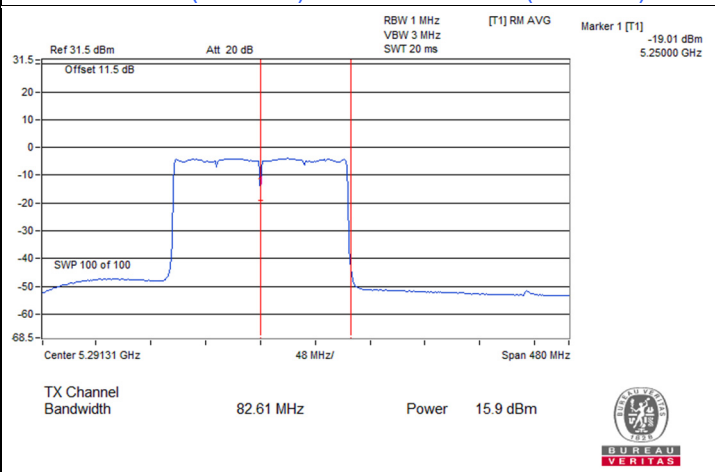

802.11be (EHT160) / Chain 3 : CH 50 (U-NII-2A)

7.3 Power Spectral Density

Input Power:	120 Vac, 60 Hz	Environmental Conditions:	25°C, 60% RH	Tested By:	Gary Lin / Frank Liu
--------------	----------------	---------------------------	--------------	------------	----------------------

802.11a

Chan.	Chan. Freq. (MHz)	PSD (dBm/MHz)				Total PSD (dBm/MHz)	Max. PSD Limit (dBm/MHz)	Test Result
		Chain 0	Chain 1	Chain 2	Chain 3			
36	5180	9.83	9.77	9.46	9.47	15.66	16.95	Pass
40	5200	10.23	10.11	10.01	10.38	16.21	16.95	Pass
48	5240	10.14	10.43	9.91	10.14	16.18	16.95	Pass
52	5260	4.12	4.52	3.65	4.02	10.11	10.94	Pass
60	5300	4.00	4.44	4.28	3.94	10.19	10.94	Pass
64	5320	3.76	4.12	4.45	3.77	10.06	10.94	Pass
100	5500	4.11	4.13	3.94	4.20	10.12	10.79	Pass
116	5580	3.66	4.16	3.70	4.37	10.00	10.79	Pass
140	5700	4.28	4.06	3.83	4.09	10.09	10.79	Pass
144 (U-NII-2C)	5720	3.83	4.15	3.84	4.42	10.09	10.79	Pass

Notes:

- Method E) 2) a) of power density measurement of KDB 662911 is using for calculating total power density. Total power density is summing entire spectra across corresponding frequency bins on the various outputs by computer.
- Directional gain is the measured value according to KDB 662911 D03 Method of MIMO Antenna Gain Measurement.
- For U-NII-1, the directional gain is 6.05 dBi > 6dBi, so the power density limit shall be reduced to $17-(6.05-6) = 16.95$ dBm/MHz.
- For U-NII-2A, the directional gain is 6.06 dBi > 6 dBi, so the power density limit shall be reduced to $11-(6.06-6) = 10.94$ dBm/MHz.
- For U-NII-2C, the directional gain is 6.21 dBi > 6 dBi, so the power density limit shall be reduced to $11-(6.21-6) = 10.79$ dBm/MHz.

802.11be (EHT20)

Chan.	Chan. Freq. (MHz)	PSD (dBm/MHz)				Total PSD (dBm/MHz)	Max. PSD Limit (dBm/MHz)	Test Result
		Chain 0	Chain 1	Chain 2	Chain 3			
36	5180	8.96	8.83	8.98	9.09	14.99	16.95	Pass
40	5200	10.00	10.02	9.86	10.35	16.08	16.95	Pass
48	5240	9.97	9.98	9.50	10.24	15.95	16.95	Pass
52	5260	3.99	4.10	4.03	3.95	10.04	10.94	Pass
60	5300	4.24	4.32	3.87	4.10	10.16	10.94	Pass
64	5320	4.16	4.36	3.94	3.74	10.08	10.94	Pass
100	5500	4.13	4.35	3.98	4.12	10.17	10.79	Pass
116	5580	3.72	4.27	3.93	4.75	10.21	10.79	Pass
140	5700	4.32	3.91	3.93	4.06	10.08	10.79	Pass
144 (U-NII-2C)	5720	3.87	3.94	3.87	4.22	10.00	10.79	Pass

Notes:

1. Method E) 2) a) of power density measurement of KDB 662911 is using for calculating total power density. Total power density is summing entire spectra across corresponding frequency bins on the various outputs by computer.
2. Directional gain is the measured value according to KDB 662911 D03 Method of MIMO Antenna Gain Measurement.
3. For U-NII-1, the directional gain is 6.05 dBi > 6dBi, so the power density limit shall be reduced to $17-(6.05-6) = 16.95$ dBm/MHz.
4. For U-NII-2A, the directional gain is 6.06 dBi > 6 dBi, so the power density limit shall be reduced to $11-(6.06-6) = 10.94$ dBm/MHz.
5. For U-NII-2C, the directional gain is 6.21 dBi > 6 dBi, so the power density limit shall be reduced to $11-(6.21-6) = 10.79$ dBm/MHz.

802.11be (EHT40)

Chan.	Chan. Freq. (MHz)	PSD (dBm/MHz)				Total PSD (dBm/MHz)	Max. PSD Limit (dBm/MHz)	Test Result
		Chain 0	Chain 1	Chain 2	Chain 3			
38	5190	4.57	4.70	3.99	4.35	10.43	16.95	Pass
46	5230	7.29	7.57	6.52	7.15	13.17	16.95	Pass
54	5270	1.07	1.47	1.21	0.84	7.17	10.94	Pass
62	5310	1.28	1.24	1.10	0.72	7.11	10.94	Pass
102	5510	1.02	1.30	0.38	1.13	6.99	10.79	Pass
110	5550	1.20	1.19	0.72	1.22	7.11	10.79	Pass
134	5670	0.79	0.96	1.26	0.97	7.02	10.79	Pass
142 (U-NII-2C)	5710	0.88	1.23	0.83	1.17	7.05	10.79	Pass

Notes:

- Method E) 2) a) of power density measurement of KDB 662911 is using for calculating total power density. Total power density is summing entire spectra across corresponding frequency bins on the various outputs by computer.
- Directional gain is the measured value according to KDB 662911 D03 Method of MIMO Antenna Gain Measurement.
- For U-NII-1, the directional gain is 6.05 dBi > 6dBi, so the power density limit shall be reduced to $17-(6.05-6) = 16.95$ dBm/MHz.
- For U-NII-2A, the directional gain is 6.06 dBi > 6 dBi, so the power density limit shall be reduced to $11-(6.06-6) = 10.94$ dBm/MHz.
- For U-NII-2C, the directional gain is 6.21 dBi > 6 dBi, so the power density limit shall be reduced to $11-(6.21-6) = 10.79$ dBm/MHz.

802.11be (EHT80)

Chan.	Chan. Freq. (MHz)	PSD (dBm/MHz)				Total PSD (dBm/MHz)	Max. PSD Limit (dBm/MHz)	Test Result
		Chain 0	Chain 1	Chain 2	Chain 3			
42	5210	1.38	1.56	1.19	1.65	7.47	16.95	Pass
58	5290	-1.90	-1.58	-1.84	-2.14	4.16	10.94	Pass
106	5530	-1.76	-1.34	-2.29	-1.93	4.20	10.79	Pass
122	5610	-1.63	-1.58	-2.75	-1.50	4.18	10.79	Pass
138 (U-NII-2C)	5690	-1.51	-1.80	-2.62	-1.66	4.14	10.79	Pass

Notes:

- Method E) 2) a) of power density measurement of KDB 662911 is using for calculating total power density. Total power density is summing entire spectra across corresponding frequency bins on the various outputs by computer.
- Directional gain is the measured value according to KDB 662911 D03 Method of MIMO Antenna Gain Measurement.
- For U-NII-1, the directional gain is 6.05 dBi > 6dBi, so the power density limit shall be reduced to $17-(6.05-6) = 16.95$ dBm/MHz.
- For U-NII-2A, the directional gain is 6.06 dBi > 6 dBi, so the power density limit shall be reduced to $11-(6.06-6) = 10.94$ dBm/MHz.
- For U-NII-2C, the directional gain is 6.21 dBi > 6 dBi, so the power density limit shall be reduced to $11-(6.21-6) = 10.79$ dBm/MHz.

802.11be (EHT160)

Chan.	Chan. Freq. (MHz)	PSD (dBm/MHz)				Total PSD (dBm/MHz)	Max. PSD Limit (dBm/MHz)	Test Result
		Chain 0	Chain 1	Chain 2	Chain 3			
50 (U-NII-1)	5250	-3.39	-2.95	-3.44	-3.07	2.81	16.95	Pass
50 (U-NII-2A)	5250	-2.81	-2.66	-3.61	-3.29	2.94	10.94	Pass
114	5570	-4.91	-4.29	-5.75	-5.26	1.00	10.79	Pass

Notes:

1. Method E) 2) a) of power density measurement of KDB 662911 is using for calculating total power density. Total power density is summing entire spectra across corresponding frequency bins on the various outputs by computer.
2. Directional gain is the measured value according to KDB 662911 D03 Method of MIMO Antenna Gain Measurement.
3. For U-NII-1, the directional gain is 6.05 dBi > 6dBi, so the power density limit shall be reduced to $17-(6.05-6) = 16.95$ dBm/MHz.
4. For U-NII-2A, the directional gain is 6.06 dBi > 6 dBi, so the power density limit shall be reduced to $11-(6.06-6) = 10.94$ dBm/MHz.
5. For U-NII-2C, the directional gain is 6.21 dBi > 6 dBi, so the power density limit shall be reduced to $11-(6.21-6) = 10.79$ dBm/MHz.

Spectrum Plot of Maximum Value

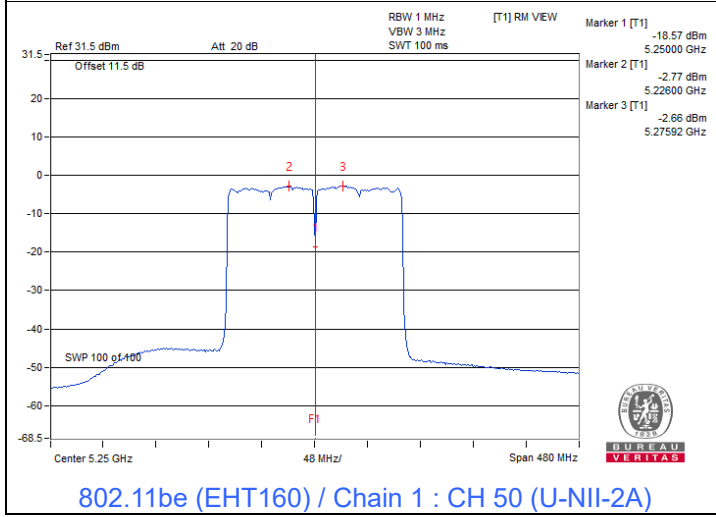
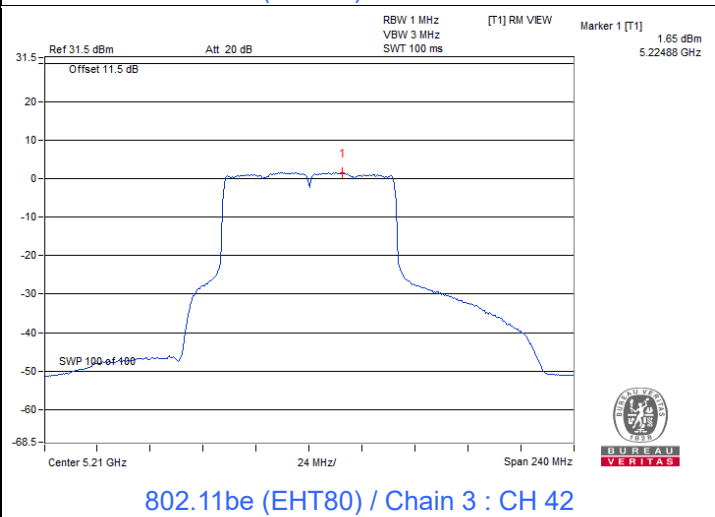
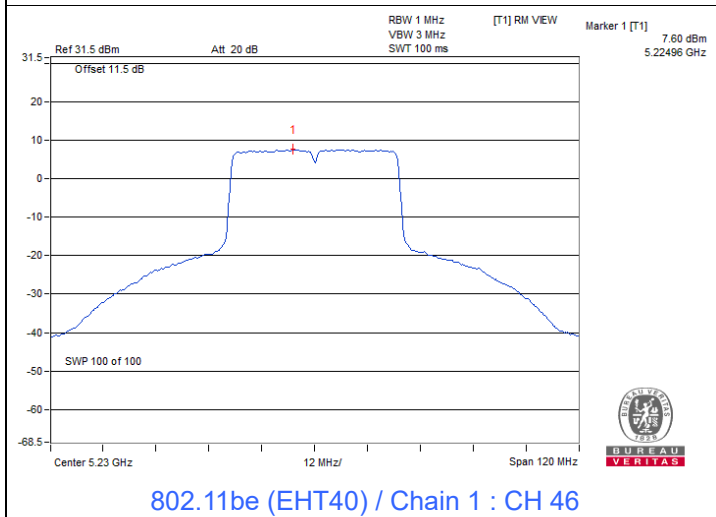
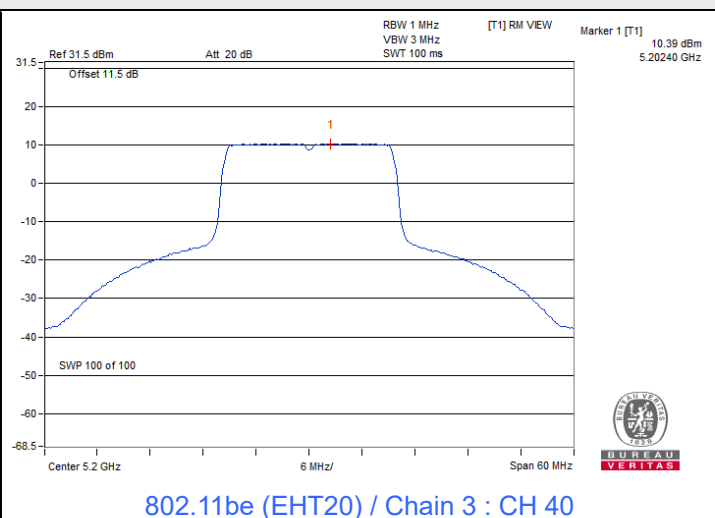
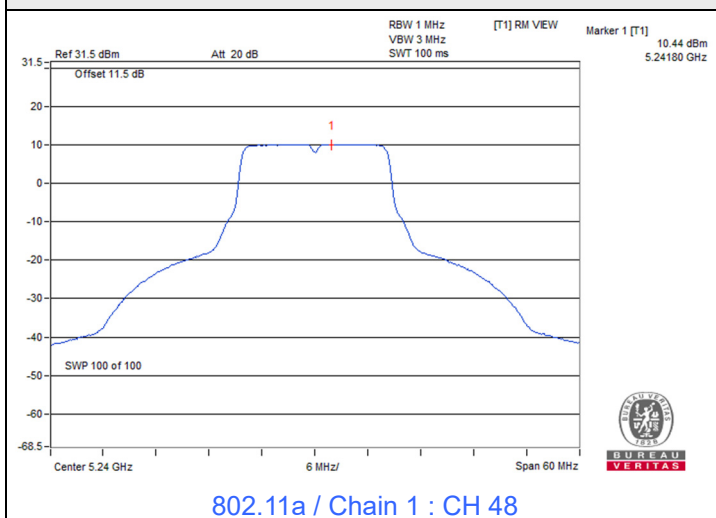

802.11a

Chan.	Chan. Freq. (MHz)	PSD (dBm/300kHz)				Total PSD (dBm/300kHz)	Total PSD (dBm/500kHz)	PSD Limit (dBm/500kHz)	Test Result
		Chain 0	Chain 1	Chain 2	Chain 3				
144 (U-NII-3)	5720	-3.82	-3.76	-4.16	-3.63	2.18	4.40	29.67	Pass
149	5745	1.37	1.45	0.95	1.29	7.29	9.51	29.67	Pass
157	5785	1.07	1.56	1.01	1.07	7.2	9.42	29.67	Pass
165	5825	1.28	1.15	0.53	1.66	7.19	9.41	29.67	Pass

Notes:

1. Method E) 2) b) Measure and sum spectral maxima across the outputs of KDB 662911 is using for calculating total power density.
2. Directional gain is the measured value according to KDB 662911 D03 Method of MIMO Antenna Gain Measurement.
3. For U-NII-3, the directional gain is 6.33 dBi > 6 dBi, so the power density limit shall be reduced to $30-(6.33-6) = 29.67$ dBm/500kHz.

802.11be (EHT20)

Chan.	Chan. Freq. (MHz)	PSD (dBm/300kHz)				Total PSD (dBm/300kHz)	Total PSD (dBm/500kHz)	PSD Limit (dBm/500kHz)	Test Result
		Chain 0	Chain 1	Chain 2	Chain 3				
144 (U-NII-3)	5720	-5.84	-5.70	-6.10	-6.30	0.04	2.26	29.67	Pass
149	5745	-1.34	-1.10	-1.49	-1.42	4.69	6.91	29.67	Pass
157	5785	-1.59	-1.22	-1.58	-1.24	4.62	6.84	29.67	Pass
165	5825	-1.04	-1.20	-1.93	-0.84	4.79	7.01	29.67	Pass

Notes:

1. Method E) 2) b) Measure and sum spectral maxima across the outputs of KDB 662911 is using for calculating total power density.
2. Directional gain is the measured value according to KDB 662911 D03 Method of MIMO Antenna Gain Measurement.
3. For U-NII-3, the directional gain is 6.33 dBi > 6 dBi, so the power density limit shall be reduced to $30-(6.33-6) = 29.67$ dBm/500kHz.

802.11be (EHT40)

Chan.	Chan. Freq. (MHz)	PSD (dBm/300kHz)				Total PSD (dBm/300kHz)	Total PSD (dBm/500kHz)	PSD Limit (dBm/500kHz)	Test Result
		Chain 0	Chain 1	Chain 2	Chain 3				
142 (U-NII-3)	5710	-8.03	-8.07	-8.44	-7.55	-1.99	0.23	29.67	Pass
151	5755	-4.51	-4.26	-4.40	-4.71	1.55	3.77	29.67	Pass
159	5795	-4.58	-4.28	-4.44	-4.40	1.6	3.82	29.67	Pass

Notes:

1. Method E) 2) b) Measure and sum spectral maxima across the outputs of KDB 662911 is using for calculating total power density.
2. Directional gain is the measured value according to KDB 662911 D03 Method of MIMO Antenna Gain Measurement.
3. For U-NII-3, the directional gain is 6.33 dBi > 6 dBi, so the power density limit shall be reduced to $30-(6.33-6) = 29.67$ dBm/500kHz.

802.11be (EHT80)

Chan.	Chan. Freq. (MHz)	PSD (dBm/300kHz)				Total PSD (dBm/300kHz)	Total PSD (dBm/500kHz)	PSD Limit (dBm/500kHz)	Test Result
		Chain 0	Chain 1	Chain 2	Chain 3				
138 (U-NII-3)	5690	-11.44	-12.07	-13.16	-11.63	-6.01	-3.79	29.67	Pass
155	5775	-6.91	-6.64	-6.56	-6.60	-0.65	1.57	29.67	Pass

Notes:

1. Method E) 2) b) Measure and sum spectral maxima across the outputs of KDB 662911 is using for calculating total power density.
2. Directional gain is the measured value according to KDB 662911 D03 Method of MIMO Antenna Gain Measurement.
3. For U-NII-3, the directional gain is 6.33 dBi > 6 dBi, so the power density limit shall be reduced to $30 - (6.33 - 6) = 29.67$ dBm/500kHz.

Spectrum Plot of Maximum Value

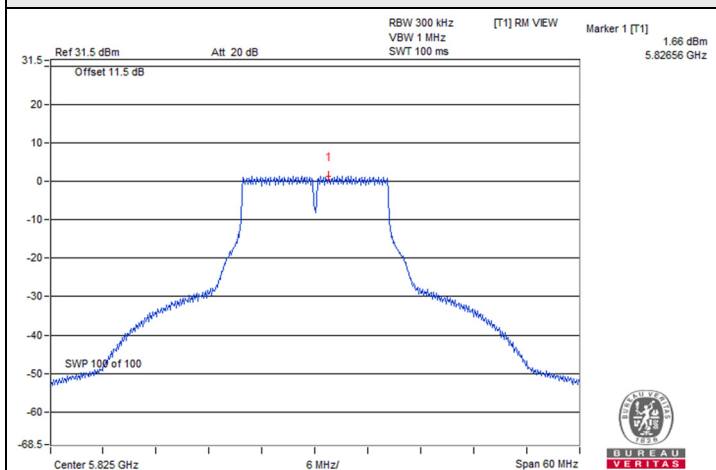

802.11a / Chain 3 : CH 165

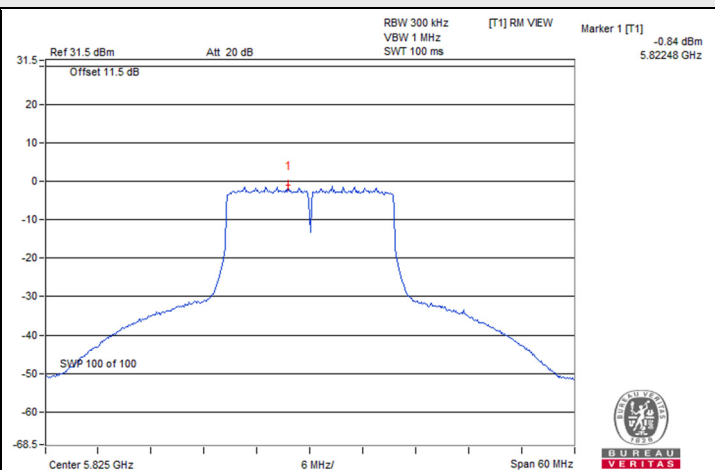

802.11be (EHT20) / Chain 3 : CH 165

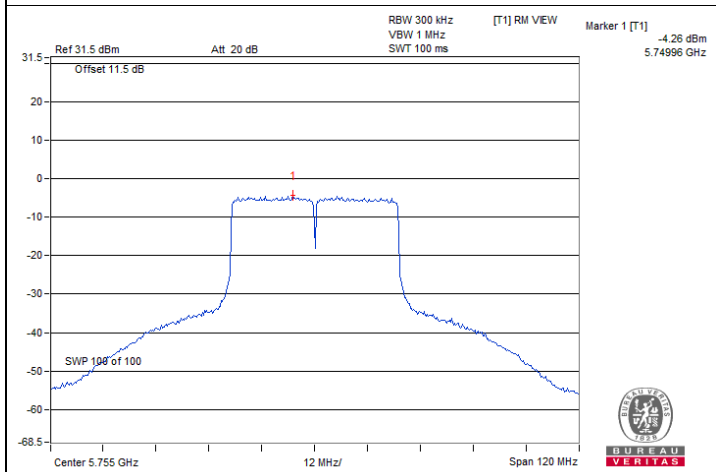

802.11be (EHT40) / Chain 1 : CH 151

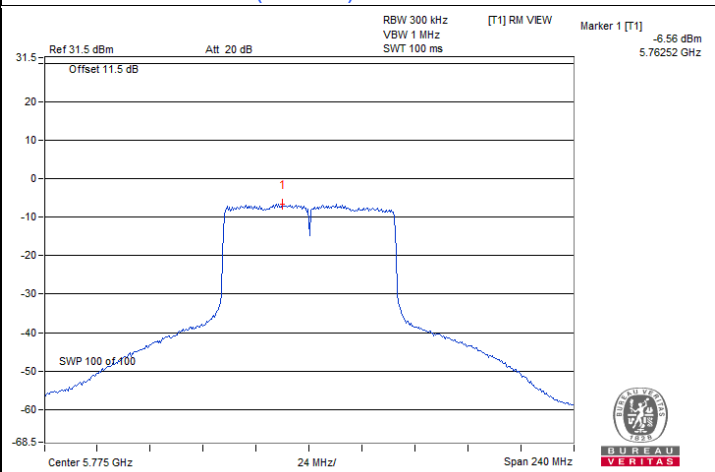

802.11be (EHT80) / Chain 2 : CH 155

7.4 6 dB Bandwidth

Input Power:	120 Vac, 60 Hz	Environmental Conditions:	25°C, 60% RH	Tested By:	Gary Lin / Frank Liu
--------------	----------------	---------------------------	--------------	------------	----------------------

802.11a

Channel	Frequency (MHz)	6 dB Bandwidth (MHz)				Minimum Limit (MHz)	Test Result
		Chain 0	Chain 1	Chain 2	Chain 3		
144 (U-NII-3)	5720	3.19	3.19	3.20	3.20	0.5	Pass
149	5745	16.39	16.40	16.40	16.42	0.5	Pass
157	5785	16.40	16.44	16.39	16.41	0.5	Pass
165	5825	16.40	16.39	16.41	16.41	0.5	Pass

802.11be (EHT20)

Channel	Frequency (MHz)	6 dB Bandwidth (MHz)				Minimum Limit (MHz)	Test Result
		Chain 0	Chain 1	Chain 2	Chain 3		
144 (U-NII-3)	5720	4.51	4.49	4.51	4.51	0.5	Pass
149	5745	19.05	19.01	19.04	19.01	0.5	Pass
157	5785	19.03	19.11	19.03	19.09	0.5	Pass
165	5825	19.05	19.08	19.07	19.03	0.5	Pass

802.11be (EHT40)

Channel	Frequency (MHz)	6 dB Bandwidth (MHz)				Minimum Limit (MHz)	Test Result
		Chain 0	Chain 1	Chain 2	Chain 3		
142 (U-NII-3)	5710	3.98	3.98	3.97	3.92	0.5	Pass
151	5755	38.00	37.88	38.02	37.99	0.5	Pass
159	5795	37.89	37.90	37.88	37.87	0.5	Pass

802.11be (EHT80)

Channel	Frequency (MHz)	6 dB Bandwidth (MHz)				Minimum Limit (MHz)	Test Result
		Chain 0	Chain 1	Chain 2	Chain 3		
138 (U-NII-3)	5690	4.01	3.89	3.67	3.68	0.5	Pass
155	5775	76.73	77.51	77.12	77.85	0.5	Pass

Spectrum Plot of Minimum Value

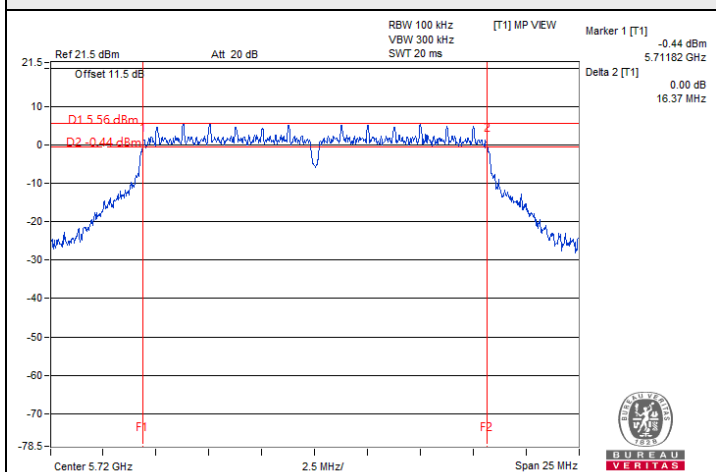

802.11a / Chain 0 : CH 144 (U-NII-3)

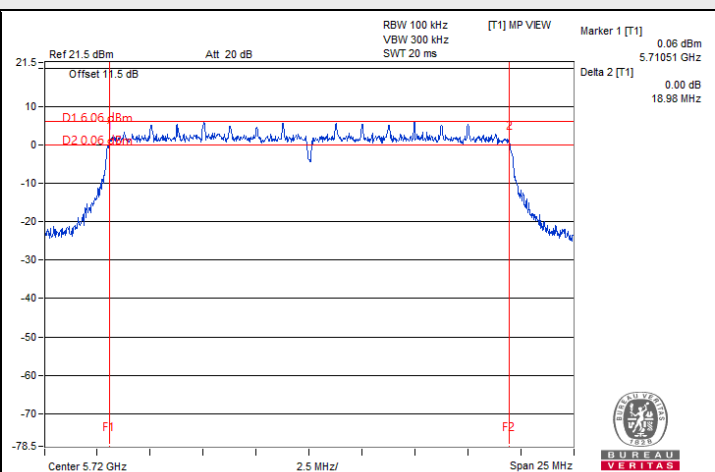

802.11be (EHT20) / Chain 1 : CH 144 (U-NII-3)

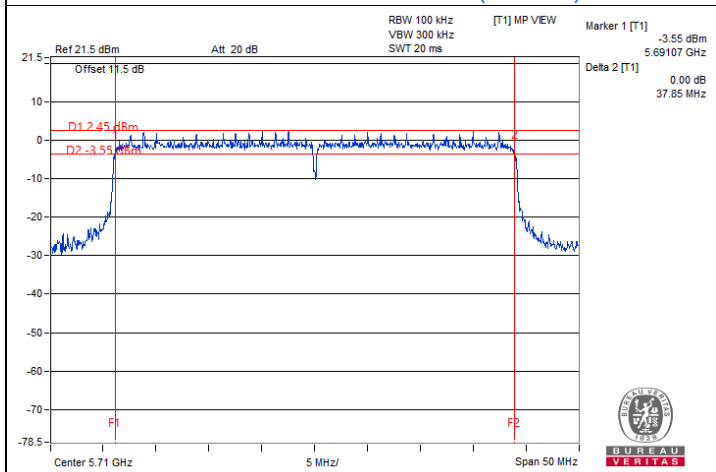

802.11be (EHT40) / Chain 3 : CH 142 (U-NII-3)

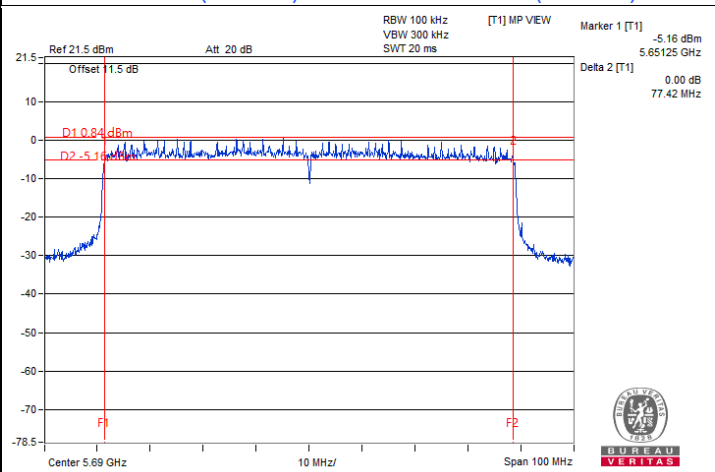

802.11be (EHT80) / Chain 2 : CH 138 (U-NII-3)

Note: For U-NII-3 straddle channel = Marker 1 + Delta 2 - 5725 MHz

7.5 Occupied Bandwidth

Input Power:	120 Vac, 60 Hz	Environmental Conditions:	25°C, 60% RH	Tested By:	Gary Lin / Frank Liu
--------------	----------------	---------------------------	--------------	------------	----------------------

802.11a

Channel	Frequency (MHz)	Occupied Bandwidth (MHz)			
		Chain 0	Chain 1	Chain 2	Chain 3
36	5180	17.65	17.48	17.48	17.31
40	5200	17.48	17.57	17.39	17.31
48	5240	17.82	17.48	17.48	17.39
52	5260	17.48	17.57	17.40	17.48
60	5300	17.56	17.40	17.39	17.40
64	5320	17.56	17.56	17.48	17.57
100	5500	17.66	17.48	17.48	17.48
116	5580	17.57	17.48	17.40	17.40
140	5700	17.13	17.13	17.04	16.95
144 (U-NII-2C)	5720	13.64	13.76	13.76	13.64
144 (U-NII-3)	5720	3.64	3.64	3.64	3.52
149	5745	17.92	17.48	17.40	17.31
157	5785	17.66	17.56	17.40	17.31
165	5825	17.74	17.65	17.56	17.31

802.11be (EHT20)

Channel	Frequency (MHz)	Occupied Bandwidth (MHz)			
		Chain 0	Chain 1	Chain 2	Chain 3
36	5180	19.39	19.30	19.30	19.22
40	5200	19.39	19.39	19.30	19.30
48	5240	19.39	19.30	19.30	19.30
52	5260	19.39	19.39	19.39	19.39
60	5300	19.39	19.22	19.39	19.30
64	5320	19.30	19.30	19.39	19.39
100	5500	19.39	19.39	19.39	19.39
116	5580	19.39	19.30	19.30	19.30
140	5700	19.22	19.14	19.14	19.22
144 (U-NII-2C)	5720	14.72	14.72	14.72	14.72
144 (U-NII-3)	5720	4.60	4.60	4.72	4.72
149	5745	19.39	19.39	19.30	19.30
157	5785	19.30	19.30	19.30	19.30
165	5825	19.30	19.39	19.30	19.30

802.11be (EHT40)

Channel	Frequency (MHz)	Occupied Bandwidth (MHz)			
		Chain 0	Chain 1	Chain 2	Chain 3
38	5190	38.26	38.26	38.09	38.26
46	5230	38.26	38.26	38.26	38.09
54	5270	38.09	38.09	38.26	38.26
62	5310	38.26	38.26	38.26	38.26
102	5510	38.09	38.26	38.26	38.26
110	5550	38.26	38.26	38.26	38.26
134	5670	38.26	38.26	38.09	38.26
142 (U-NII-2C)	5710	34.20	34.20	34.20	34.20
142 (U-NII-3)	5710	3.96	3.96	3.96	3.96
151	5755	38.26	38.26	38.26	38.26
159	5795	38.26	38.26	38.09	38.26

802.11be (EHT80)

Channel	Frequency (MHz)	Occupied Bandwidth (MHz)			
		Chain 0	Chain 1	Chain 2	Chain 3
42	5210	77.57	77.57	77.22	77.57
58	5290	77.57	77.57	77.92	77.92
106	5530	77.22	77.57	77.92	77.57
122	5610	77.57	77.57	77.92	77.57
138 (U-NII-2C)	5690	73.88	73.88	73.88	73.88
138 (U-NII-3)	5690	3.64	3.40	3.40	3.40
155	5775	77.57	77.22	77.22	77.57

802.11be (EHT160)

Channel	Frequency (MHz)	Occupied Bandwidth (MHz)			
		Chain 0	Chain 1	Chain 2	Chain 3
50 (U-NII-1)	5250	78.24	78.24	78.72	78.24
50 (U-NII-2A)	5250	78.24	78.24	78.72	78.24
114	5570	156.52	156.52	157.22	157.22

Spectrum Plot of Maximum Value

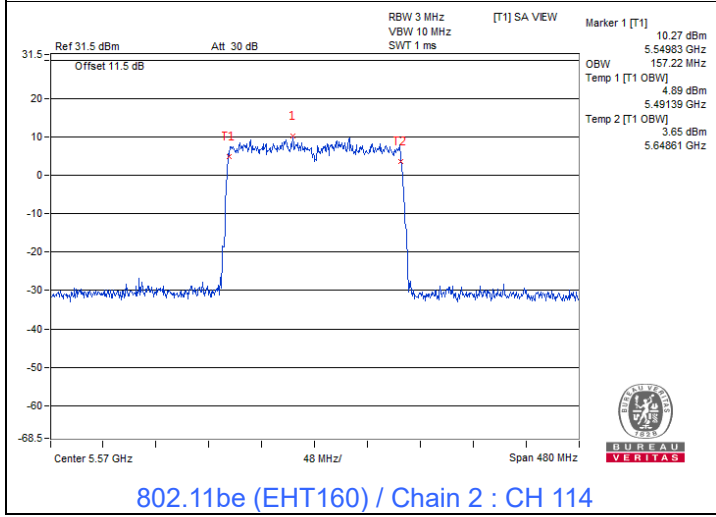
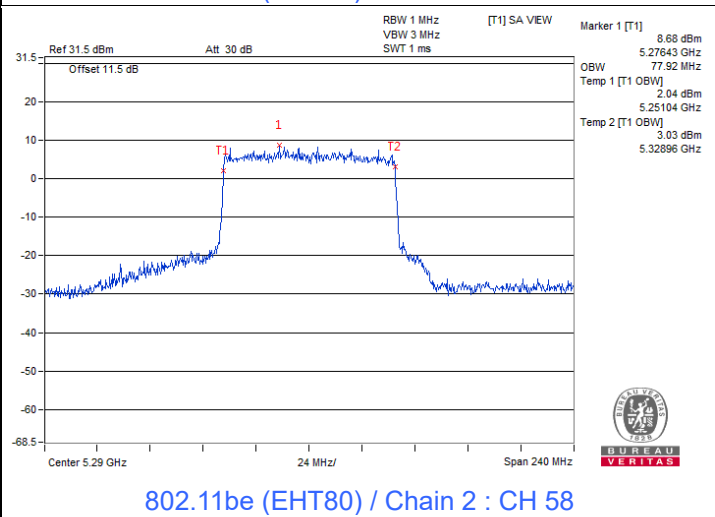
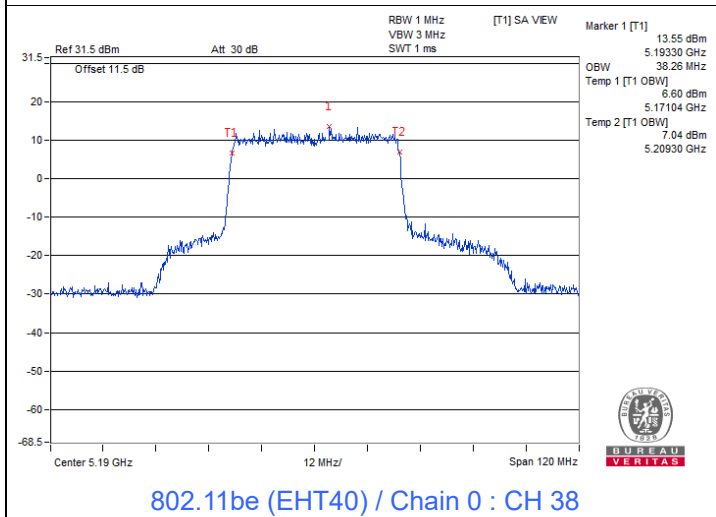
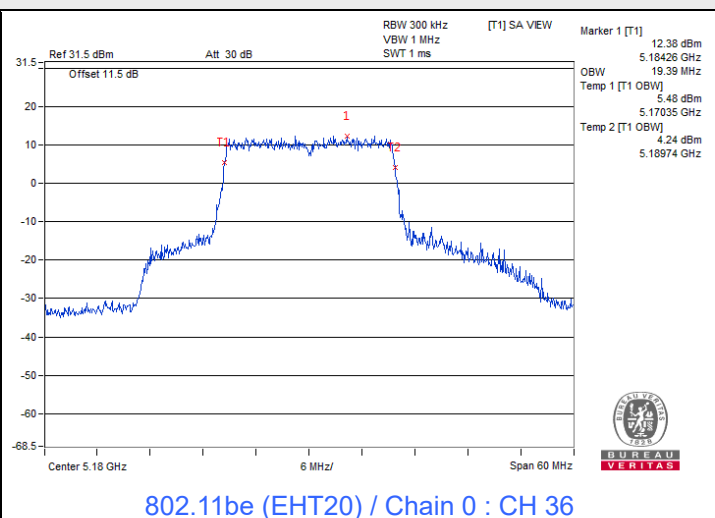
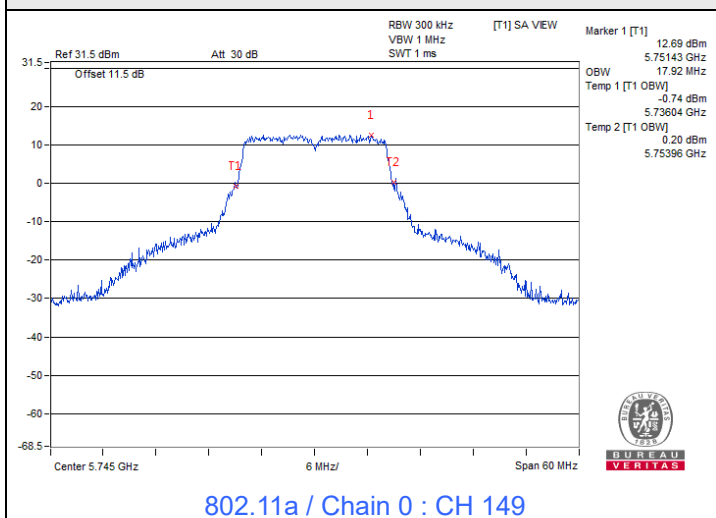

**Spectrum Plot for nearby DFS band
(DFS is required, if 99% OCP straddle into U-NII-2A)**

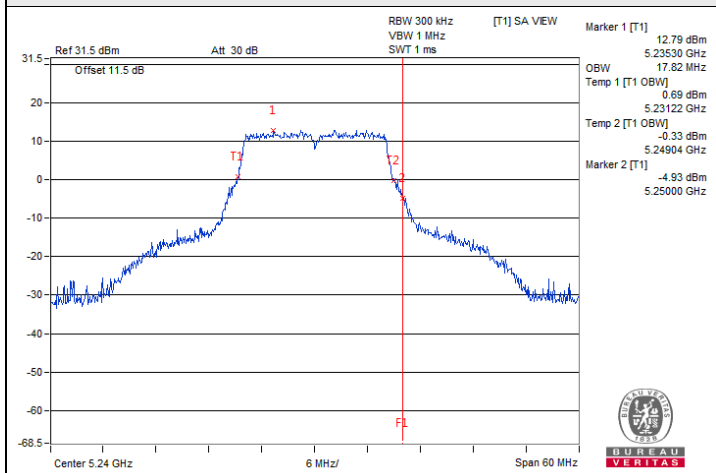

802.11a / Chain 0 : CH 48

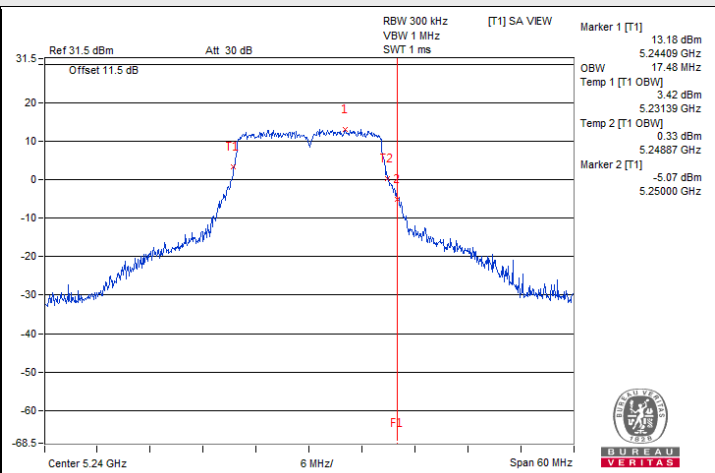

802.11a / Chain 1 : CH 48

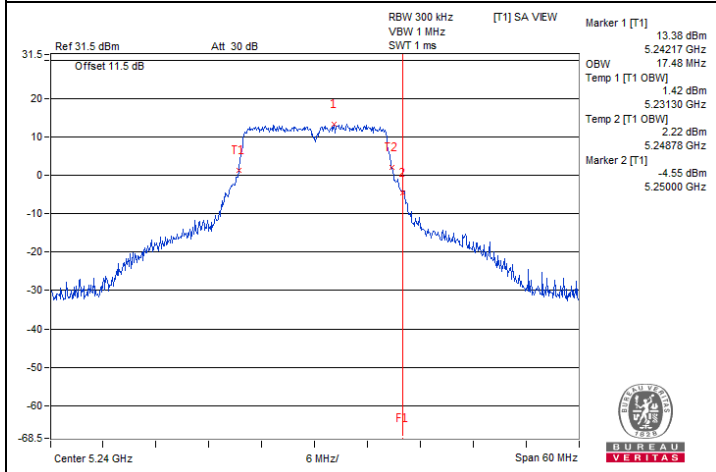

802.11a / Chain 2 : CH 48

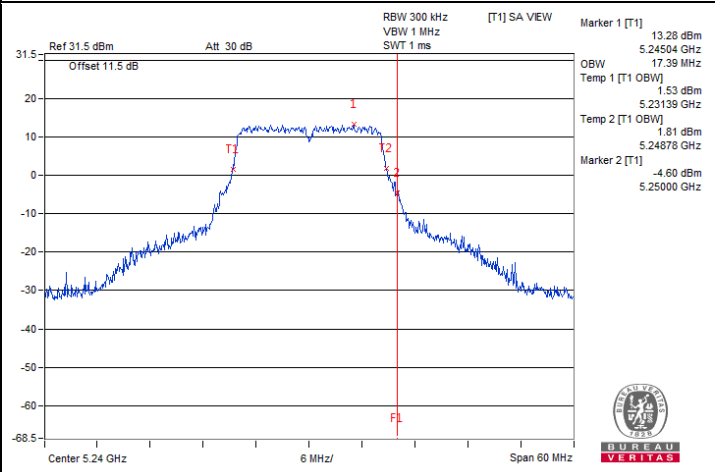

802.11a / Chain 3 : CH 48

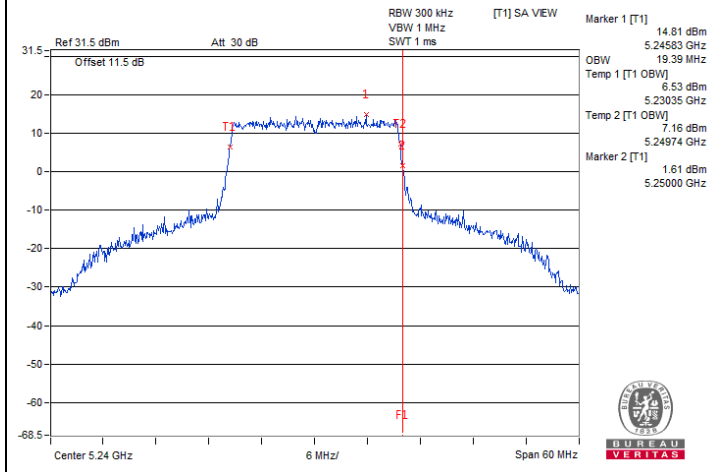

802.11be (EHT20) / Chain 0 : CH 48

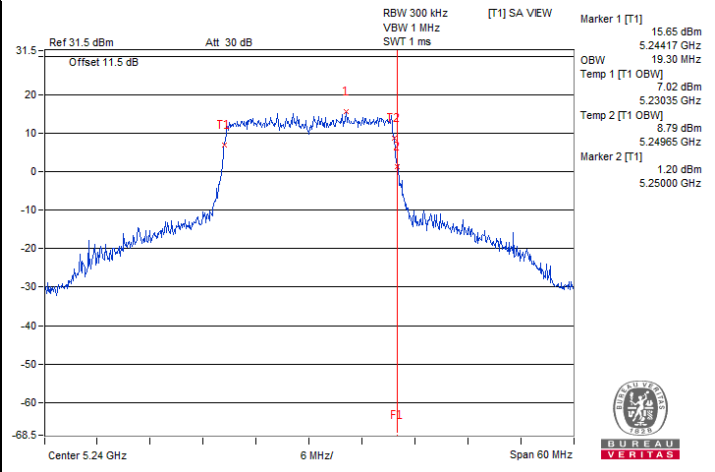

802.11be (EHT20) / Chain 1 : CH 48

Spectrum Plot for nearby DFS band (DFS is required, if 99% OCP straddle into U-NII-2A)

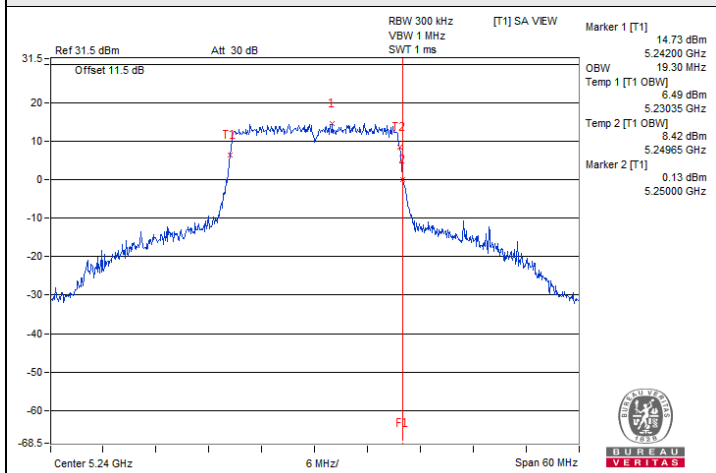

802.11be (EHT20) / Chain 2 : CH 48

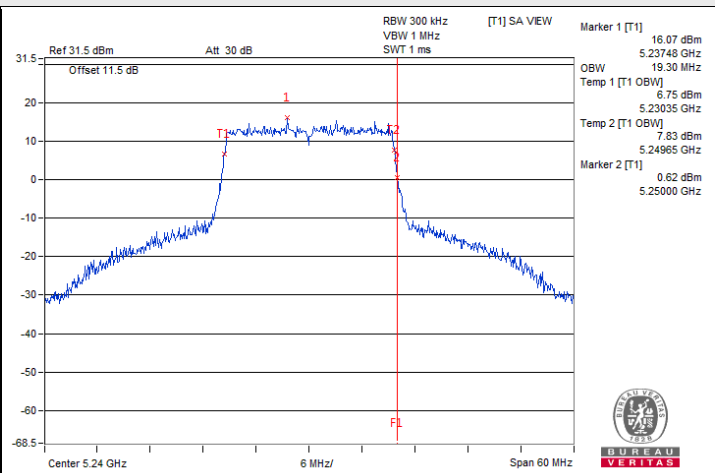

802.11be (EHT20) / Chain 3 : CH 48

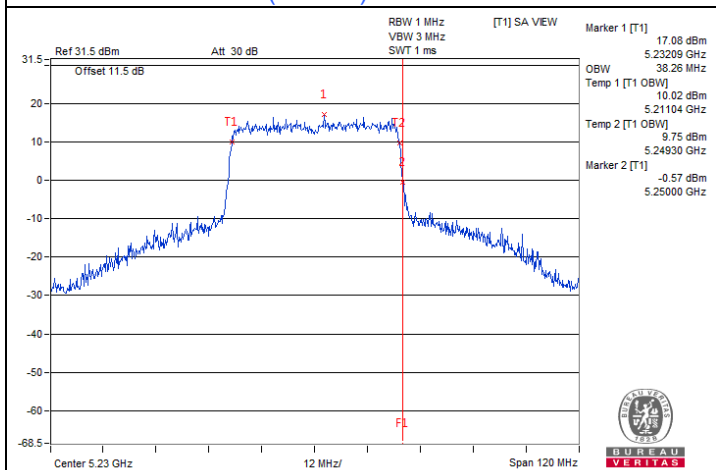

802.11be (EHT40) / Chain 0 : CH 46

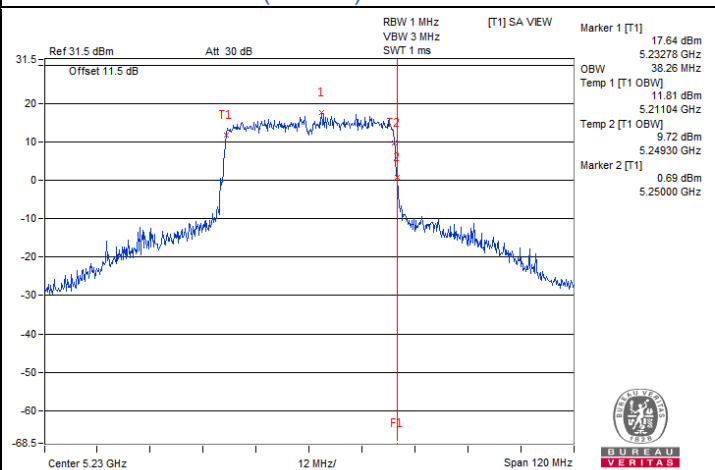

802.11be (EHT40) / Chain 1 : CH 46

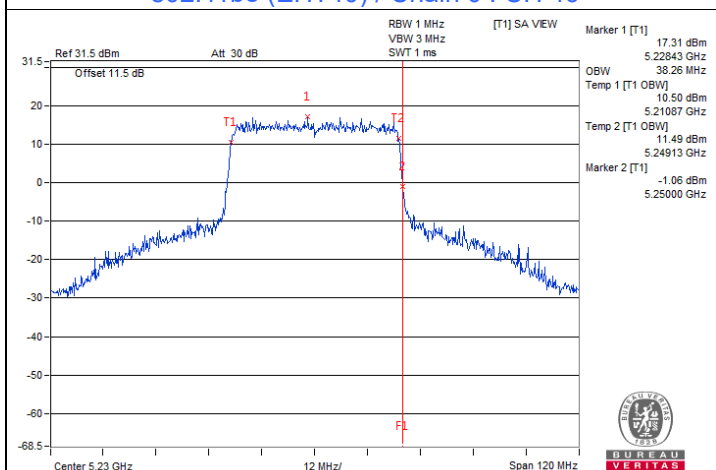

802.11be (EHT40) / Chain 2 : CH 46

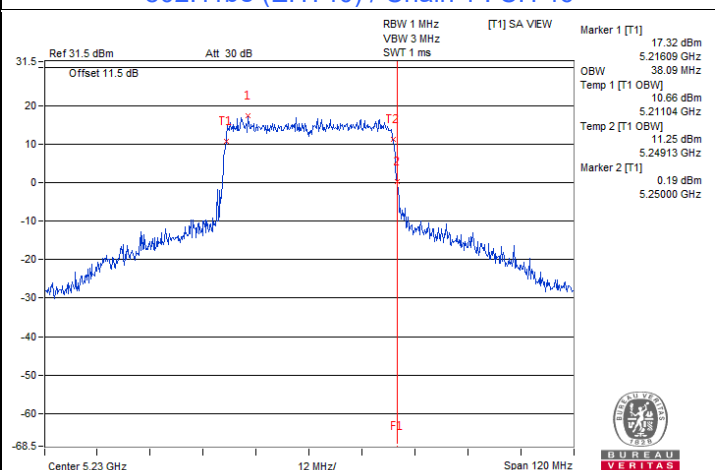

802.11be (EHT40) / Chain 3 : CH 46

Spectrum Plot for nearby DFS band (DFS is required, if 99% OCP straddle into U-NII-2A)

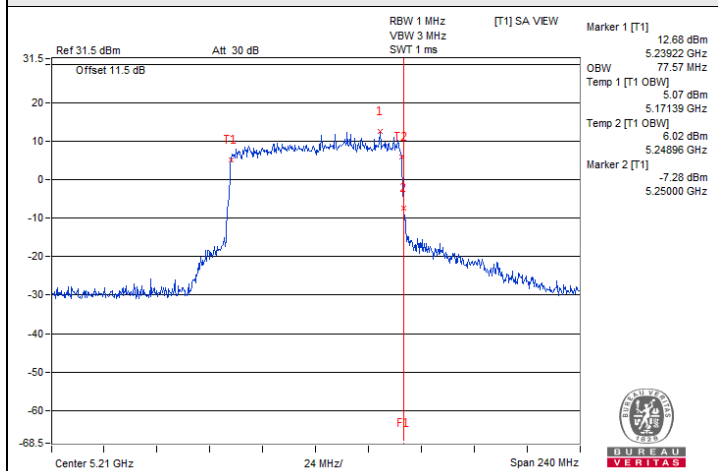

802.11be (EHT80) / Chain 0 : CH 42

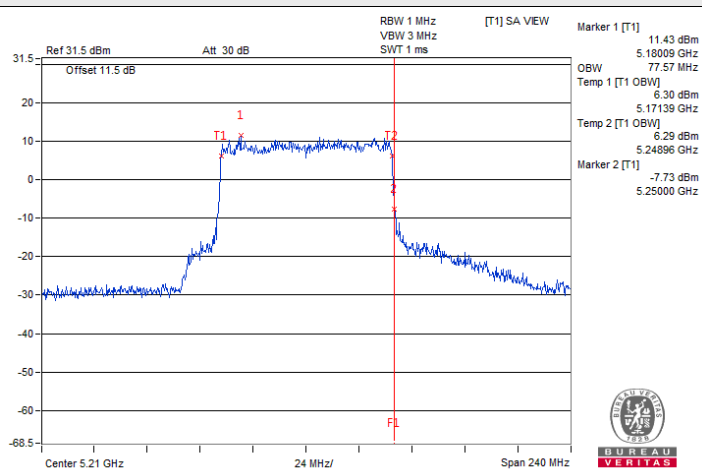

802.11be (EHT80) / Chain 1 : CH 42

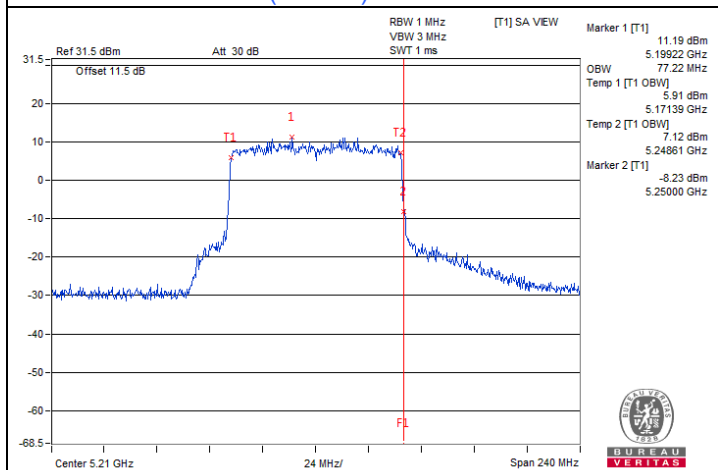

802.11be (EHT80) / Chain 2 : CH 42

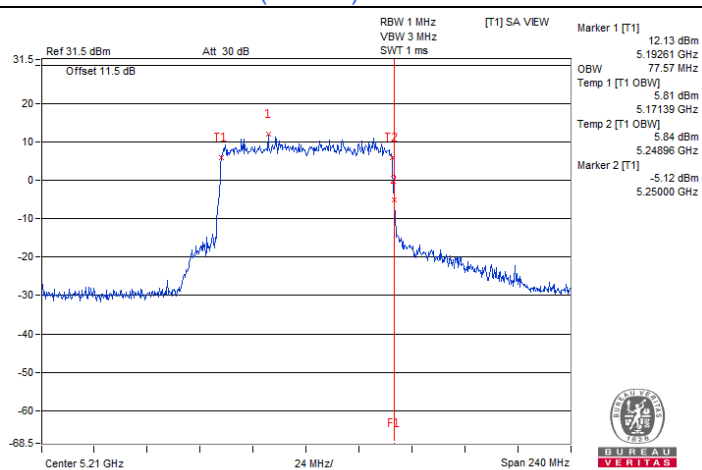

802.11be (EHT80) / Chain 3 : CH 42

Spectrum Plot for nearby DFS band (DFS is required, if 99% OCP straddle into U-NII-2C)

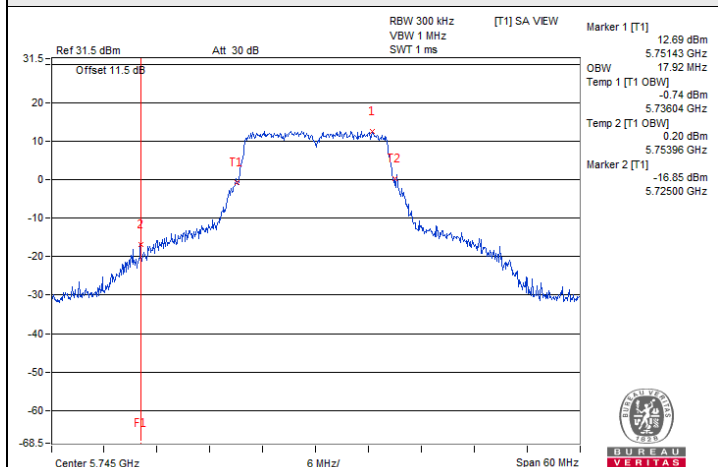
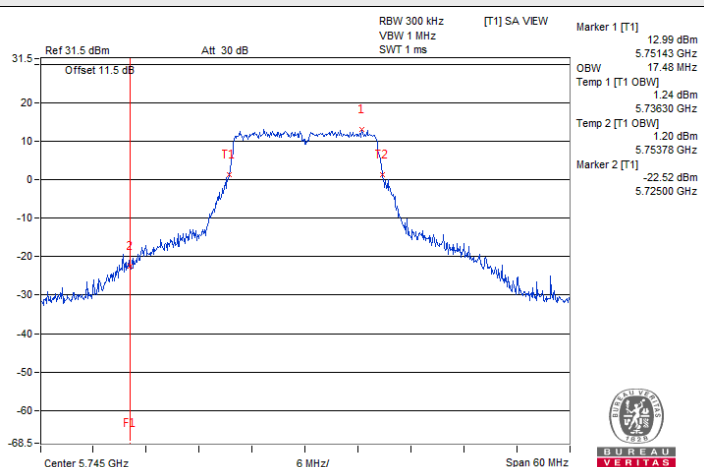
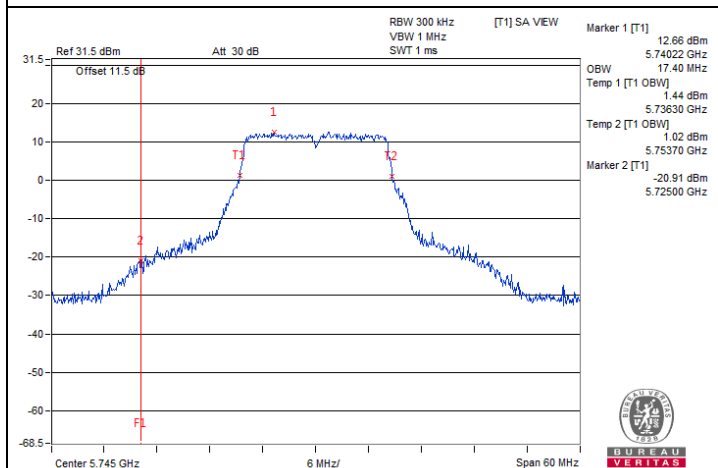
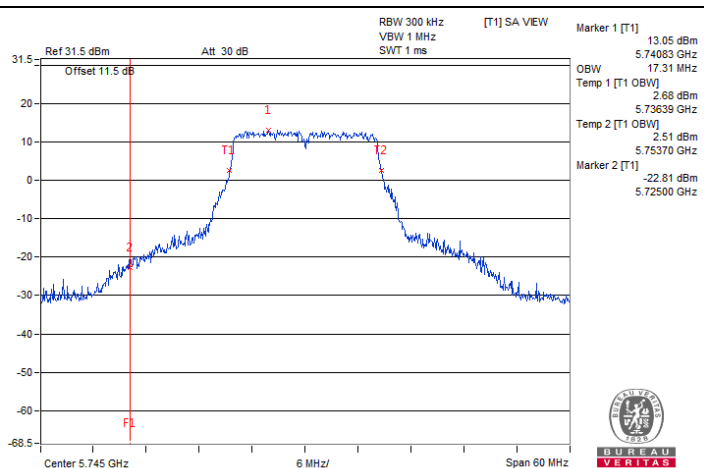
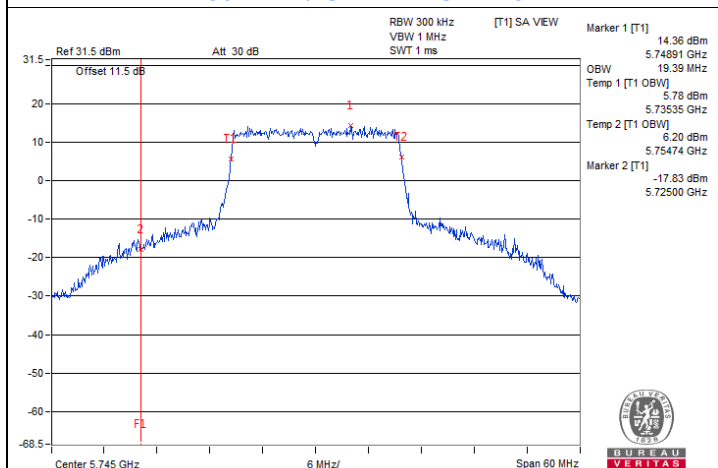
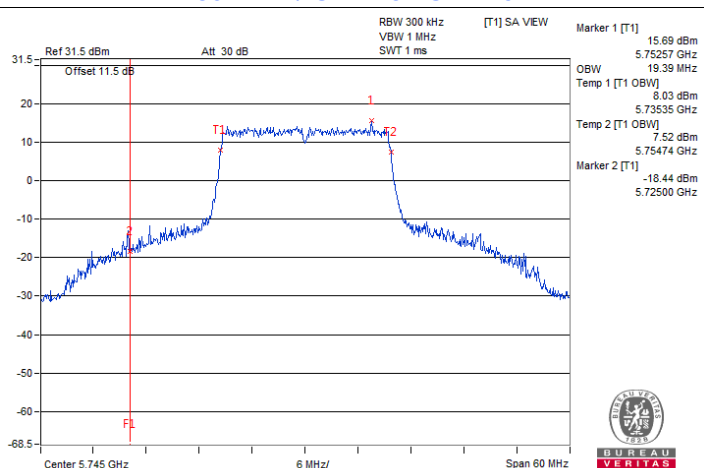
**802.11a / Chain 0 : CH 149****802.11a / Chain 1 : CH 149****802.11a / Chain 2 : CH 149****802.11a / Chain 3 : CH 149****802.11be (EHT20) / Chain 0 : CH 149****802.11be (EHT20) / Chain 1 : CH 149**



Spectrum Plot for nearby DFS band (DFS is required, if 99% OCP straddle into U-NII-2C)

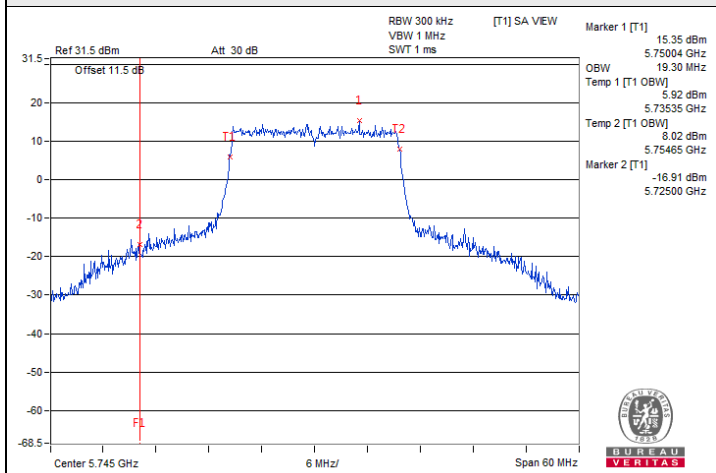

802.11be (EHT20) / Chain 2 : CH 149

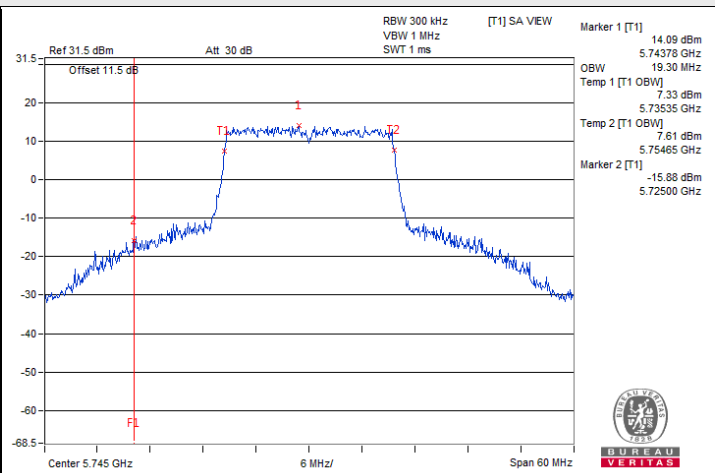

802.11be (EHT20) / Chain 3 : CH 149

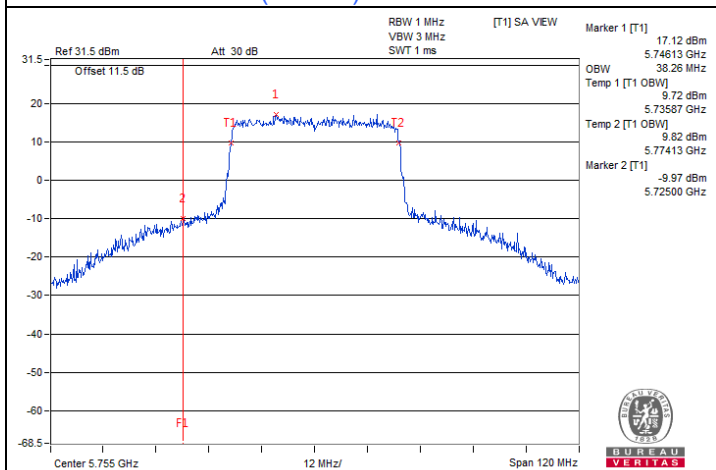

802.11be (EHT40) / Chain 0 : CH 151

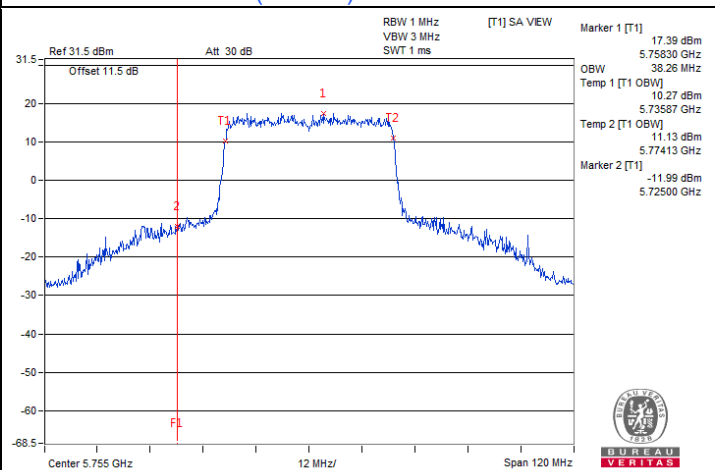

802.11be (EHT40) / Chain 1 : CH 151

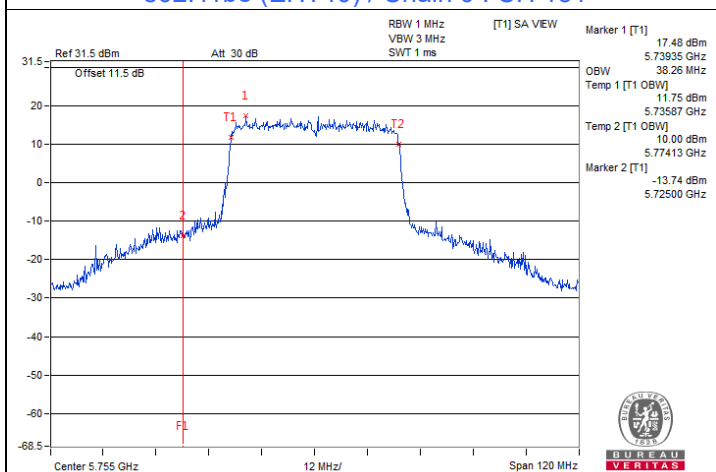

802.11be (EHT40) / Chain 2 : CH 151

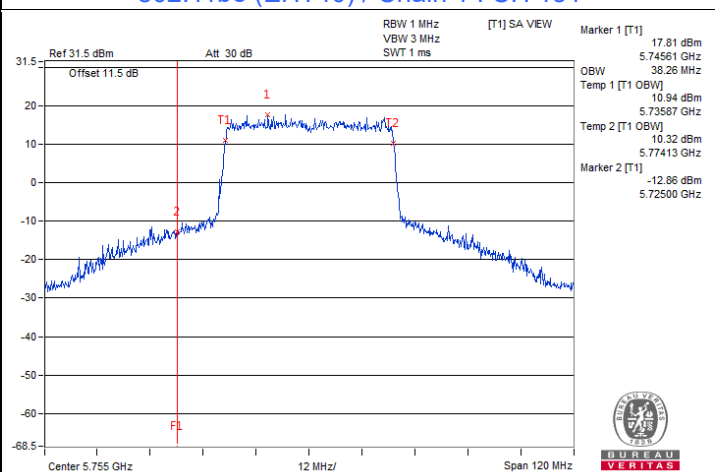

802.11be (EHT40) / Chain 3 : CH 151



Spectrum Plot for nearby DFS band (DFS is required, if 99% OCP straddle into U-NII-2C)

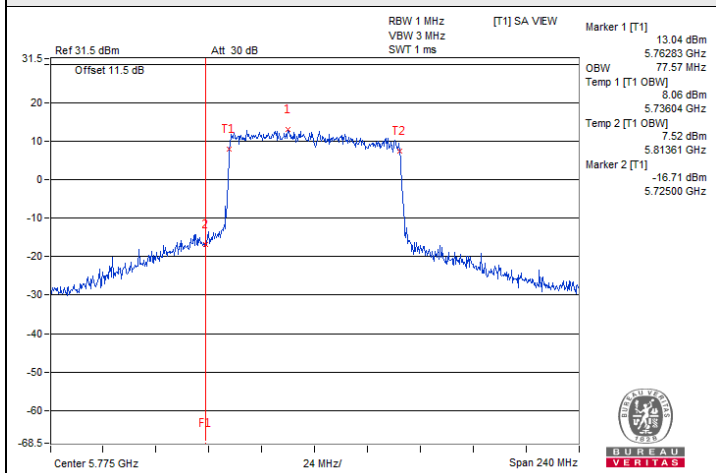

802.11be (EHT80) / Chain 0 : CH 155

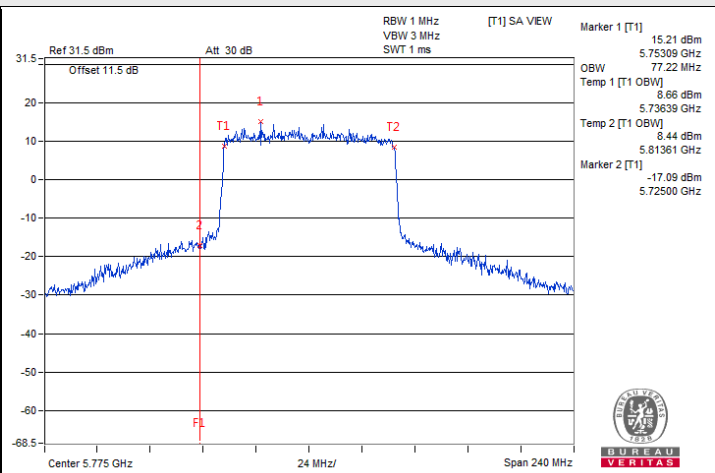

802.11be (EHT80) / Chain 1 : CH 155

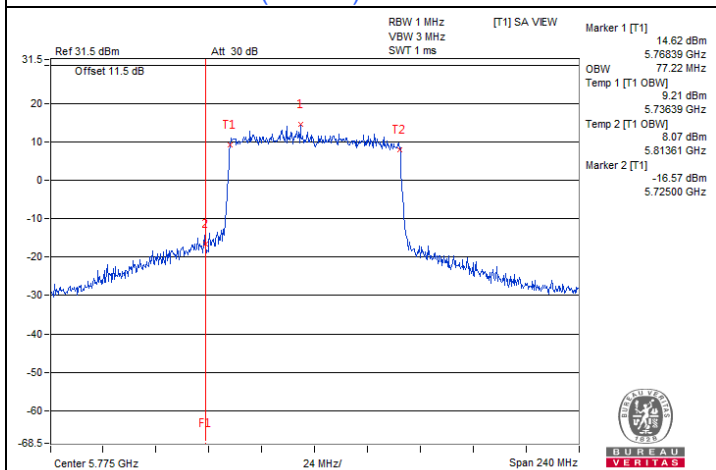

802.11be (EHT80) / Chain 2 : CH 155

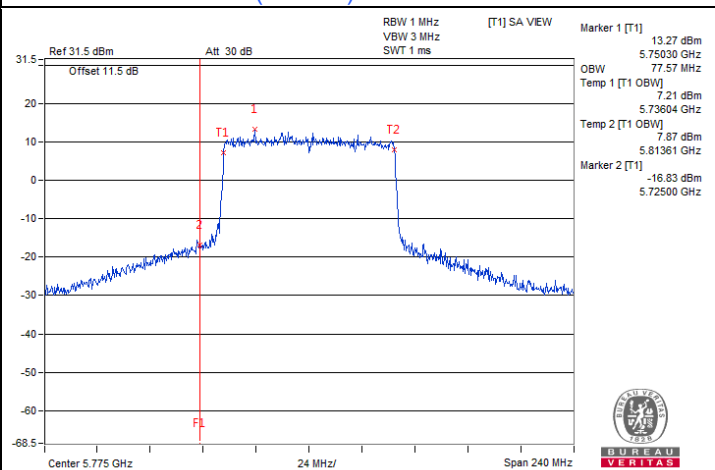

802.11be (EHT80) / Chain 3 : CH 155

7.6 Frequency Stability

Input Power:	120 Vac, 60 Hz	Environmental Conditions:	25°C, 60% RH	Tested By:	Gary Lin / Frank Liu
--------------	----------------	---------------------------	--------------	------------	----------------------

Frequency Stability Versus Temperature									
Operating Frequency: 5180 MHz									
Temp. (°C)	Power Supply (Vac)	0 Minute		2 Minutes		5 Minutes		10 Minutes	
		Measured Frequency (MHz)	Test Result	Measured Frequency (MHz)	Test Result	Measured Frequency (MHz)	Test Result	Measured Frequency (MHz)	Test Result
40	120	5180.0208	Pass	5180.0197	Pass	5180.0217	Pass	5180.0207	Pass
30	120	5180.0071	Pass	5180.003	Pass	5180.0064	Pass	5180.0064	Pass
20	120	5179.9977	Pass	5180.0004	Pass	5179.9974	Pass	5179.9987	Pass
10	120	5180.009	Pass	5180.0108	Pass	5180.0094	Pass	5180.0098	Pass
0	120	5180.0259	Pass	5180.0256	Pass	5180.025	Pass	5180.0268	Pass

Frequency Stability Versus Voltage									
Operating Frequency: 5180 MHz									
Temp. (°C)	Power Supply (Vac)	0 Minute		2 Minutes		5 Minutes		10 Minutes	
		Measured Frequency (MHz)	Test Result	Measured Frequency (MHz)	Test Result	Measured Frequency (MHz)	Test Result	Measured Frequency (MHz)	Test Result
20	138	5179.9906	Pass	5179.9928	Pass	5179.9901	Pass	5179.9906	Pass
	120	5179.9977	Pass	5180.0004	Pass	5179.9974	Pass	5179.9987	Pass
	102	5179.9991	Pass	5179.9994	Pass	5179.9957	Pass	5179.9979	Pass

7.7 AC Power Conducted Emissions

RF Mode	802.11be (EHT40)	Channel	CH 151 : 5755 MHz
Frequency Range	150 kHz ~ 30 MHz	Detector Function & Resolution Bandwidth	Quasi-Peak (QP) / Average (AV), 9 kHz
Input Power	120 Vac, 60 Hz	Environmental Conditions	23 °C, 67 % RH
Tested By	Adair Peng		

Phase Of Power : Line (L)										
No	Frequency (MHz)	Correction Factor (dB)	Reading Value (dBuV)		Emission Level (dBuV)		Limit (dBuV)		Margin (dB)	
			Q.P.	AV.	Q.P.	AV.	Q.P.	AV.	Q.P.	AV.
1	0.17708	9.72	28.05	15.80	37.77	25.52	64.62	54.62	-26.85	-29.10
2	0.27400	9.76	23.74	11.23	33.50	20.99	61.00	51.00	-27.50	-30.01
3	0.29400	9.77	27.81	15.18	37.58	24.95	60.41	50.41	-22.83	-25.46
4	0.53000	9.84	14.95	4.86	24.79	14.70	56.00	46.00	-31.21	-31.30
5	1.49000	9.92	13.55	6.24	23.47	16.16	56.00	46.00	-32.53	-29.84
6	14.32600	10.25	10.16	5.05	20.41	15.30	60.00	50.00	-39.59	-34.70

Remarks:

1. Q.P. and AV. are abbreviations of quasi-peak and average individually.
2. The emission levels of other frequencies were very low against the limit.
3. Margin value = Emission level – Limit value
4. Correction factor = Insertion loss + Cable loss
5. Emission Level = Correction Factor + Reading Value

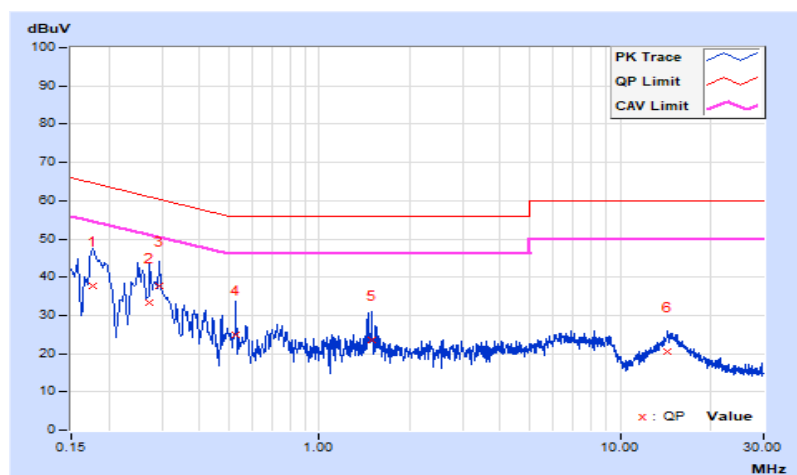

RF Mode	802.11be (EHT40)	Channel	CH 151 : 5755 MHz
Frequency Range	150 kHz ~ 30 MHz	Detector Function & Resolution Bandwidth	Quasi-Peak (QP) / Average (AV), 9 kHz
Input Power	120 Vac, 60 Hz	Environmental Conditions	23 °C, 67 % RH
Tested By	Adair Peng		

Phase Of Power : Neutral (N)										
No	Frequency (MHz)	Correction Factor (dB)	Reading Value (dBuV)		Emission Level (dBuV)		Limit (dBuV)		Margin (dB)	
			Q.P.	AV.	Q.P.	AV.	Q.P.	AV.	Q.P.	AV.
1	0.15770	9.69	35.54	19.24	45.23	28.93	65.58	55.58	-20.35	-26.65
2	0.18600	9.70	34.95	25.69	44.65	35.39	64.21	54.21	-19.56	-18.82
3	0.23400	9.74	31.05	20.74	40.79	30.48	62.31	52.31	-21.52	-21.83
4	0.31800	9.80	26.25	14.44	36.05	24.24	59.76	49.76	-23.71	-25.52
5	1.51000	9.95	13.12	5.77	23.07	15.72	56.00	46.00	-32.93	-30.28
6	15.25800	10.39	8.93	4.52	19.32	14.91	60.00	50.00	-40.68	-35.09

Remarks:

1. Q.P. and AV. are abbreviations of quasi-peak and average individually.
2. The emission levels of other frequencies were very low against the limit.
3. Margin value = Emission level – Limit value
4. Correction factor = Insertion loss + Cable loss
5. Emission Level = Correction Factor + Reading Value

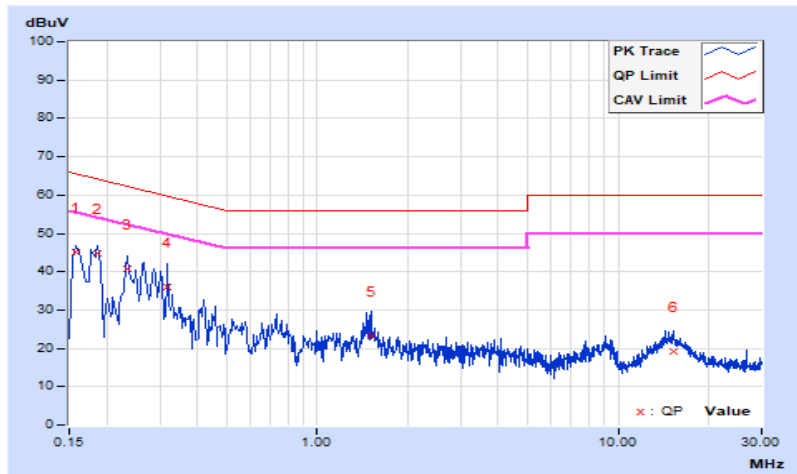

7.8 Unwanted Emissions below 1 GHz

RF Mode	802.11be (EHT40)	Channel	CH 151 : 5755 MHz
Frequency Range	30 MHz ~ 1 GHz	Detector Function & Bandwidth	QP: RB=120kHz, DET=Quasi-Peak
Input Power	120 Vac, 60 Hz	Environmental Conditions	23 °C, 66 % RH
Tested By	Luis Lee		

Antenna Polarity & Test Distance : Horizontal at 3 m								
No	Frequency (MHz)	Emission Level (dBuV/m)	Limit (dBuV/m)	Margin (dB)	Antenna Height (m)	Table Angle (Degree)	Raw Value (dBuV)	Correction Factor (dB/m)
1	35.82	27.2 QP	40.0	-12.8	1.00 H	250	37.1	-9.9
2	146.40	23.5 QP	43.5	-20.0	1.00 H	92	32.2	-8.7
3	244.37	23.0 QP	46.0	-23.0	1.50 H	244	32.6	-9.6
4	346.22	27.8 QP	46.0	-18.2	1.50 H	328	34.6	-6.8
5	528.58	28.3 QP	46.0	-17.7	1.00 H	6	31.6	-3.3
6	597.45	29.3 QP	46.0	-16.7	1.50 H	291	30.8	-1.5

Remarks:

1. Emission Level(dBuV/m) = Raw Value(dBuV) + Correction Factor(dB/m)
2. Correction Factor(dB/m) = Antenna Factor(dB/m) + Cable Factor(dB) – Pre-Amplifier Factor(dB)
3. Margin value = Emission Level – Limit value
4. The other emission levels were very low against the limit of frequency range 30 MHz ~ 1 GHz.
5. The frequency range 9 kHz ~ 30 MHz: all emissions are more than 20 dB below the limit, therefore do not be recorded in this report.

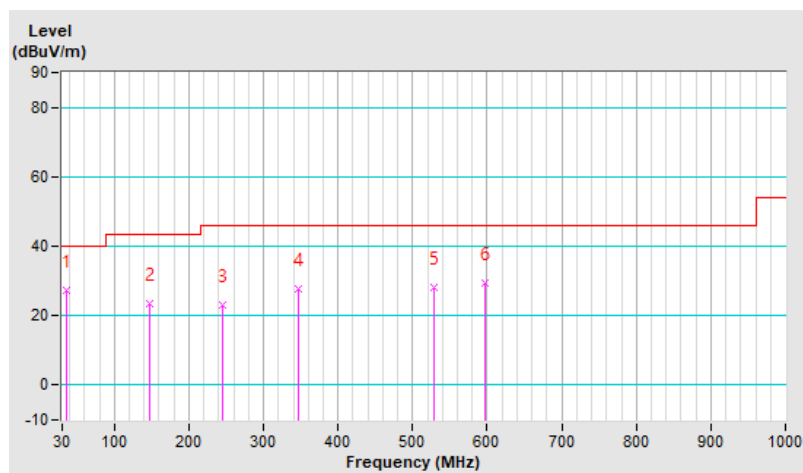

RF Mode	802.11be (EHT40)	Channel	CH 151 : 5755 MHz
Frequency Range	30 MHz ~ 1 GHz	Detector Function & Bandwidth	QP: RB=120kHz, DET=Quasi-Peak
Input Power	120 Vac, 60 Hz	Environmental Conditions	23 °C, 66 % RH
Tested By	Luis Lee		

Antenna Polarity & Test Distance : Vertical at 3 m								
No	Frequency (MHz)	Emission Level (dBuV/m)	Limit (dBuV/m)	Margin (dB)	Antenna Height (m)	Table Angle (Degree)	Raw Value (dBuV)	Correction Factor (dB/m)
1	50.37	33.5 QP	40.0	-6.5	1.00 V	305	42.1	-8.6
2	173.56	24.2 QP	43.5	-19.3	1.00 V	303	33.5	-9.3
3	441.28	27.2 QP	46.0	-18.8	1.50 V	349	32.0	-4.8
4	512.09	28.3 QP	46.0	-17.7	1.50 V	136	31.8	-3.5
5	634.31	30.3 QP	46.0	-15.7	1.50 V	63	31.0	-0.7
6	704.15	31.3 QP	46.0	-14.7	1.00 V	352	30.9	0.4

Remarks:

1. Emission Level(dBuV/m) = Raw Value(dBuV) + Correction Factor(dB/m)
2. Correction Factor(dB/m) = Antenna Factor(dB/m) + Cable Factor(dB) – Pre-Amplifier Factor(dB)
3. Margin value = Emission Level – Limit value
4. The other emission levels were very low against the limit of frequency range 30 MHz ~ 1 GHz.
5. The frequency range 9 kHz ~ 30 MHz: all emissions are more than 20 dB below the limit, therefore do not be recorded in this report.

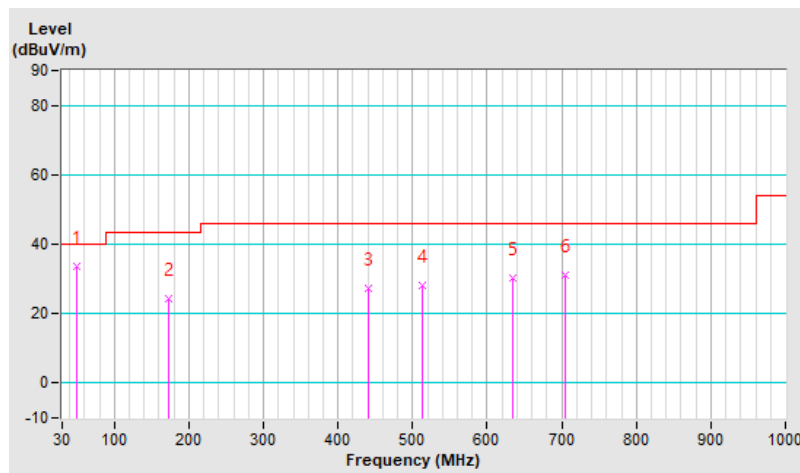

7.9 Unwanted Emissions above 1 GHz

RF Mode	802.11a	Channel	CH 36 : 5180 MHz
Frequency Range	1 GHz ~ 40 GHz	Detector Function & Bandwidth	PK: RB=1 MHz, VB=3 MHz, DET=Peak AV: RB=1 MHz, VB=10 Hz, DET=Peak
Input Power	120 Vac, 60 Hz	Environmental Conditions	23 °C, 66 % RH
Tested By	Luis Lee		

Antenna Polarity & Test Distance : Horizontal at 3 m

No	Frequency (MHz)	Emission Level (dBuV/m)	Limit (dBuV/m)	Margin (dB)	Antenna Height (m)	Table Angle (Degree)	Raw Value (dBuV)	Correction Factor (dB/m)
1	5150.00	61.5 PK	74.0	-12.5	1.66 H	92	48.4	13.1
2	5150.00	48.5 AV	54.0	-5.5	1.66 H	92	35.4	13.1
3	*5180.00	116.0 PK			1.66 H	92	72.6	43.4
4	*5180.00	106.9 AV			1.66 H	92	63.5	43.4
5	#10360.00	59.5 PK	68.2	-8.7	1.66 H	174	37.8	21.7

Antenna Polarity & Test Distance : Vertical at 3 m

No	Frequency (MHz)	Emission Level (dBuV/m)	Limit (dBuV/m)	Margin (dB)	Antenna Height (m)	Table Angle (Degree)	Raw Value (dBuV)	Correction Factor (dB/m)
1	5150.00	66.2 PK	74.0	-7.8	1.63 V	126	53.1	13.1
2	5150.00	52.3 AV	54.0	-1.7	1.63 V	126	39.2	13.1
3	*5180.00	122.3 PK			1.63 V	126	78.9	43.4
4	*5180.00	113.2 AV			1.63 V	126	69.8	43.4
5	#10360.00	60.2 PK	68.2	-8.0	2.25 V	192	38.5	21.7

Remarks:

1. Emission Level(dBuV/m) = Raw Value(dBuV) + Correction Factor(dB/m)
2. Correction Factor(dB/m) = Antenna Factor(dB/m) + Cable Factor(dB) – Pre-Amplifier Factor(dB)
3. Margin value = Emission Level – Limit value
4. The other emission levels were very low against the limit.
5. " * " : Fundamental frequency, the limit was restricted at the RF Output Power.
6. " # " : The radiated frequency is out of the restricted band.



RF Mode	802.11a	Channel	CH 40 : 5200 MHz
Frequency Range	1 GHz ~ 40 GHz	Detector Function & Bandwidth	PK: RB=1 MHz, VB=3 MHz, DET=Peak AV: RB=1 MHz, VB=10 Hz, DET=Peak
Input Power	120 Vac, 60 Hz	Environmental Conditions	23 °C, 66 % RH
Tested By	Luis Lee		

Antenna Polarity & Test Distance : Horizontal at 3 m

No	Frequency (MHz)	Emission Level (dBuV/m)	Limit (dBuV/m)	Margin (dB)	Antenna Height (m)	Table Angle (Degree)	Raw Value (dBuV)	Correction Factor (dB/m)
1	*5200.00	116.8 PK			1.70 H	90	73.5	43.3
2	*5200.00	107.5 AV			1.70 H	90	64.2	43.3
3	#10400.00	59.7 PK	68.2	-8.5	1.42 H	190	37.9	21.8

Antenna Polarity & Test Distance : Vertical at 3 m

No	Frequency (MHz)	Emission Level (dBuV/m)	Limit (dBuV/m)	Margin (dB)	Antenna Height (m)	Table Angle (Degree)	Raw Value (dBuV)	Correction Factor (dB/m)
1	*5200.00	123.2 PK			1.70 V	124	79.9	43.3
2	*5200.00	113.9 AV			1.70 V	124	70.6	43.3
3	#10400.00	60.5 PK	68.2	-7.7	2.28 V	195	38.7	21.8

Remarks:

1. Emission Level(dBuV/m) = Raw Value(dBuV) + Correction Factor(dB/m)
2. Correction Factor(dB/m) = Antenna Factor(dB/m) + Cable Factor(dB) – Pre-Amplifier Factor(dB)
3. Margin value = Emission Level – Limit value
4. The other emission levels were very low against the limit.
5. " * ": Fundamental frequency, the limit was restricted at the RF Output Power.
6. " # ": The radiated frequency is out of the restricted band.

RF Mode	802.11a	Channel	CH 48 : 5240 MHz
Frequency Range	1 GHz ~ 40 GHz	Detector Function & Bandwidth	PK: RB=1 MHz, VB=3 MHz, DET=Peak AV: RB=1 MHz, VB=10 Hz, DET=Peak
Input Power	120 Vac, 60 Hz	Environmental Conditions	23 °C, 66 % RH
Tested By	Luis Lee		

Antenna Polarity & Test Distance : Horizontal at 3 m								
No	Frequency (MHz)	Emission Level (dBuV/m)	Limit (dBuV/m)	Margin (dB)	Antenna Height (m)	Table Angle (Degree)	Raw Value (dBuV)	Correction Factor (dB/m)
1	*5240.00	117.2 PK			1.54 H	95	74.0	43.2
2	*5240.00	107.4 AV			1.54 H	95	64.2	43.2
3	5350.00	60.7 PK	74.0	-13.3	1.54 H	95	47.6	13.1
4	5350.00	47.3 AV	54.0	-6.7	1.54 H	95	34.2	13.1
5	#10480.00	60.2 PK	68.2	-8.0	1.70 H	181	38.2	22.0

Antenna Polarity & Test Distance : Vertical at 3 m								
No	Frequency (MHz)	Emission Level (dBuV/m)	Limit (dBuV/m)	Margin (dB)	Antenna Height (m)	Table Angle (Degree)	Raw Value (dBuV)	Correction Factor (dB/m)
1	*5240.00	123.8 PK			1.63 V	125	80.6	43.2
2	*5240.00	114.2 AV			1.63 V	125	71.0	43.2
3	5350.00	61.1 PK	74.0	-12.9	1.63 V	125	48.0	13.1
4	5350.00	47.7 AV	54.0	-6.3	1.63 V	125	34.6	13.1
5	#10480.00	60.6 PK	68.2	-7.6	2.28 V	196	38.6	22.0

Remarks:

1. Emission Level(dBuV/m) = Raw Value(dBuV) + Correction Factor(dB/m)
2. Correction Factor(dB/m) = Antenna Factor(dB/m) + Cable Factor(dB) – Pre-Amplifier Factor(dB)
3. Margin value = Emission Level – Limit value
4. The other emission levels were very low against the limit.
5. " * ": Fundamental frequency, the limit was restricted at the RF Output Power.
6. " # ": The radiated frequency is out of the restricted band.



RF Mode	802.11a	Channel	CH 52 : 5260 MHz
Frequency Range	1 GHz ~ 40 GHz	Detector Function & Bandwidth	PK: RB=1 MHz, VB=3 MHz, DET=Peak AV: RB=1 MHz, VB=10 Hz, DET=Peak
Input Power	120 Vac, 60 Hz	Environmental Conditions	23 °C, 66 % RH
Tested By	Luis Lee		

Antenna Polarity & Test Distance : Horizontal at 3 m								
No	Frequency (MHz)	Emission Level (dBuV/m)	Limit (dBuV/m)	Margin (dB)	Antenna Height (m)	Table Angle (Degree)	Raw Value (dBuV)	Correction Factor (dB/m)
1	5150.00	61.0 PK	74.0	-13.0	1.73 H	330	47.9	13.1
2	5150.00	47.6 AV	54.0	-6.4	1.73 H	330	34.5	13.1
3	*5260.00	111.2 PK			1.73 H	330	67.9	43.3
4	*5260.00	101.7 AV			1.73 H	330	58.4	43.3
5	#10520.00	59.9 PK	68.2	-8.3	1.77 H	190	37.9	22.0

Antenna Polarity & Test Distance : Vertical at 3 m								
No	Frequency (MHz)	Emission Level (dBuV/m)	Limit (dBuV/m)	Margin (dB)	Antenna Height (m)	Table Angle (Degree)	Raw Value (dBuV)	Correction Factor (dB/m)
1	5150.00	61.4 PK	74.0	-12.6	1.50 V	126	48.3	13.1
2	5150.00	48.1 AV	54.0	-5.9	1.50 V	126	35.0	13.1
3	*5260.00	117.3 PK			1.50 V	126	74.0	43.3
4	*5260.00	108.0 AV			1.50 V	126	64.7	43.3
5	#10520.00	60.5 PK	68.2	-7.7	2.15 V	195	38.5	22.0

Remarks:

1. Emission Level(dBuV/m) = Raw Value(dBuV) + Correction Factor(dB/m)
2. Correction Factor(dB/m) = Antenna Factor(dB/m) + Cable Factor(dB) – Pre-Amplifier Factor(dB)
3. Margin value = Emission Level – Limit value
4. The other emission levels were very low against the limit.
5. " * " : Fundamental frequency, the limit was restricted at the RF Output Power.
6. " # " : The radiated frequency is out of the restricted band.



RF Mode	802.11a	Channel	CH 60 : 5300 MHz
Frequency Range	1 GHz ~ 40 GHz	Detector Function & Bandwidth	PK: RB=1 MHz, VB=3 MHz, DET=Peak AV: RB=1 MHz, VB=10 Hz, DET=Peak
Input Power	120 Vac, 60 Hz	Environmental Conditions	23 °C, 66 % RH
Tested By	Luis Lee		

Antenna Polarity & Test Distance : Horizontal at 3 m								
No	Frequency (MHz)	Emission Level (dBuV/m)	Limit (dBuV/m)	Margin (dB)	Antenna Height (m)	Table Angle (Degree)	Raw Value (dBuV)	Correction Factor (dB/m)
1	*5300.00	110.4 PK			1.74 H	331	67.1	43.3
2	*5300.00	100.8 AV			1.74 H	331	57.5	43.3
3	10600.00	60.2 PK	74.0	-13.8	1.74 H	185	38.1	22.1
4	10600.00	47.5 AV	54.0	-6.5	1.74 H	185	25.4	22.1

Antenna Polarity & Test Distance : Vertical at 3 m								
No	Frequency (MHz)	Emission Level (dBuV/m)	Limit (dBuV/m)	Margin (dB)	Antenna Height (m)	Table Angle (Degree)	Raw Value (dBuV)	Correction Factor (dB/m)
1	*5300.00	116.5 PK			1.59 V	125	73.2	43.3
2	*5300.00	107.1 AV			1.59 V	125	63.8	43.3
3	10600.00	60.6 PK	74.0	-13.4	2.13 V	192	38.5	22.1
4	10600.00	47.9 AV	54.0	-6.1	2.13 V	192	25.8	22.1

Remarks:

1. Emission Level(dBuV/m) = Raw Value(dBuV) + Correction Factor(dB/m)
2. Correction Factor(dB/m) = Antenna Factor(dB/m) + Cable Factor(dB) – Pre-Amplifier Factor(dB)
3. Margin value = Emission Level – Limit value
4. The other emission levels were very low against the limit.
5. " * " : Fundamental frequency, the limit was restricted at the RF Output Power.

RF Mode	802.11a	Channel	CH 64 : 5320 MHz
Frequency Range	1 GHz ~ 40 GHz	Detector Function & Bandwidth	PK: RB=1 MHz, VB=3 MHz, DET=Peak AV: RB=1 MHz, VB=10 Hz, DET=Peak
Input Power	120 Vac, 60 Hz	Environmental Conditions	23 °C, 66 % RH
Tested By	Luis Lee		

Antenna Polarity & Test Distance : Horizontal at 3 m

No	Frequency (MHz)	Emission Level (dBuV/m)	Limit (dBuV/m)	Margin (dB)	Antenna Height (m)	Table Angle (Degree)	Raw Value (dBuV)	Correction Factor (dB/m)
1	*5320.00	110.7 PK			1.73 H	330	67.2	43.5
2	*5320.00	100.6 AV			1.73 H	330	57.1	43.5
3	5350.00	60.3 PK	74.0	-13.7	1.73 H	330	47.2	13.1
4	5350.00	47.3 AV	54.0	-6.7	1.73 H	330	34.2	13.1
5	10640.00	60.6 PK	74.0	-13.4	1.76 H	188	38.1	22.5
6	10640.00	47.8 AV	54.0	-6.2	1.76 H	188	25.3	22.5

Antenna Polarity & Test Distance : Vertical at 3 m

No	Frequency (MHz)	Emission Level (dBuV/m)	Limit (dBuV/m)	Margin (dB)	Antenna Height (m)	Table Angle (Degree)	Raw Value (dBuV)	Correction Factor (dB/m)
1	*5320.00	116.9 PK			1.37 V	127	73.4	43.5
2	*5320.00	107.3 AV			1.37 V	127	63.8	43.5
3	5350.00	60.6 PK	74.0	-13.4	1.37 V	127	47.5	13.1
4	5350.00	47.6 AV	54.0	-6.4	1.37 V	127	34.5	13.1
5	10640.00	61.0 PK	74.0	-13.0	2.21 V	188	38.5	22.5
6	10640.00	48.2 AV	54.0	-5.8	2.21 V	188	25.7	22.5

Remarks:

1. Emission Level(dBuV/m) = Raw Value(dBuV) + Correction Factor(dB/m)
2. Correction Factor(dB/m) = Antenna Factor(dB/m) + Cable Factor(dB) – Pre-Amplifier Factor(dB)
3. Margin value = Emission Level – Limit value
4. The other emission levels were very low against the limit.
5. " * ": Fundamental frequency, the limit was restricted at the RF Output Power.

RF Mode	802.11a	Channel	CH 100 : 5500 MHz
Frequency Range	1 GHz ~ 40 GHz	Detector Function & Bandwidth	PK: RB=1 MHz, VB=3 MHz, DET=Peak AV: RB=1 MHz, VB=10 Hz, DET=Peak
Input Power	120 Vac, 60 Hz	Environmental Conditions	23 °C, 66 % RH
Tested By	Luis Lee		

Antenna Polarity & Test Distance : Horizontal at 3 m

No	Frequency (MHz)	Emission Level (dBuV/m)	Limit (dBuV/m)	Margin (dB)	Antenna Height (m)	Table Angle (Degree)	Raw Value (dBuV)	Correction Factor (dB/m)
1	5460.00	61.7 PK	74.0	-12.3	1.74 H	331	48.5	13.2
2	5460.00	48.7 AV	54.0	-5.3	1.74 H	331	35.5	13.2
3	#5470.00	62.3 PK	68.2	-5.9	1.74 H	331	49.0	13.3
4	*5500.00	111.7 PK			1.74 H	331	67.8	43.9
5	*5500.00	102.4 AV			1.74 H	331	58.5	43.9
6	11000.00	60.9 PK	74.0	-13.1	1.85 H	194	38.2	22.7
7	11000.00	48.8 AV	54.0	-5.2	1.85 H	194	26.1	22.7

Antenna Polarity & Test Distance : Vertical at 3 m

No	Frequency (MHz)	Emission Level (dBuV/m)	Limit (dBuV/m)	Margin (dB)	Antenna Height (m)	Table Angle (Degree)	Raw Value (dBuV)	Correction Factor (dB/m)
1	5460.00	62.0 PK	74.0	-12.0	1.67 V	324	48.8	13.2
2	5460.00	48.9 AV	54.0	-5.1	1.67 V	324	35.7	13.2
3	#5470.00	62.6 PK	68.2	-5.6	1.67 V	324	49.3	13.3
4	*5500.00	118.6 PK			1.67 V	324	74.7	43.9
5	*5500.00	109.2 AV			1.67 V	324	65.3	43.9
6	11000.00	61.1 PK	74.0	-12.9	2.30 V	197	38.4	22.7
7	11000.00	49.0 AV	54.0	-5.0	2.30 V	197	26.3	22.7

Remarks:

1. Emission Level(dBuV/m) = Raw Value(dBuV) + Correction Factor(dB/m)
2. Correction Factor(dB/m) = Antenna Factor(dB/m) + Cable Factor(dB) – Pre-Amplifier Factor(dB)
3. Margin value = Emission Level – Limit value
4. The other emission levels were very low against the limit.
5. " * " : Fundamental frequency, the limit was restricted at the RF Output Power.
6. " # " : The radiated frequency is out of the restricted band.

RF Mode	802.11a	Channel	CH 116 : 5580 MHz
Frequency Range	1 GHz ~ 40 GHz	Detector Function & Bandwidth	PK: RB=1 MHz, VB=3 MHz, DET=Peak AV: RB=1 MHz, VB=10 Hz, DET=Peak
Input Power	120 Vac, 60 Hz	Environmental Conditions	23 °C, 66 % RH
Tested By	Luis Lee		

Antenna Polarity & Test Distance : Horizontal at 3 m								
No	Frequency (MHz)	Emission Level (dBuV/m)	Limit (dBuV/m)	Margin (dB)	Antenna Height (m)	Table Angle (Degree)	Raw Value (dBuV)	Correction Factor (dB/m)
1	*5580.00	112.8 PK			1.75 H	336	69.0	43.8
2	*5580.00	102.8 AV			1.75 H	336	59.0	43.8
3	11160.00	61.0 PK	74.0	-13.0	1.74 H	187	38.2	22.8
4	11160.00	49.2 AV	54.0	-4.8	1.74 H	187	26.4	22.8
Antenna Polarity & Test Distance : Vertical at 3 m								
No	Frequency (MHz)	Emission Level (dBuV/m)	Limit (dBuV/m)	Margin (dB)	Antenna Height (m)	Table Angle (Degree)	Raw Value (dBuV)	Correction Factor (dB/m)
1	*5580.00	118.9 PK			1.69 V	322	75.1	43.8
2	*5580.00	109.1 AV			1.69 V	322	65.3	43.8
3	11160.00	61.3 PK	74.0	-12.7	2.41 V	193	38.5	22.8
4	11160.00	49.4 AV	54.0	-4.6	2.41 V	193	26.6	22.8

Remarks:

1. Emission Level(dBuV/m) = Raw Value(dBuV) + Correction Factor(dB/m)
2. Correction Factor(dB/m) = Antenna Factor(dB/m) + Cable Factor(dB) – Pre-Amplifier Factor(dB)
3. Margin value = Emission Level – Limit value
4. The other emission levels were very low against the limit.
5. " * " : Fundamental frequency, the limit was restricted at the RF Output Power.

RF Mode	802.11a	Channel	CH 140 : 5700 MHz
Frequency Range	1 GHz ~ 40 GHz	Detector Function & Bandwidth	PK: RB=1 MHz, VB=3 MHz, DET=Peak AV: RB=1 MHz, VB=10 Hz, DET=Peak
Input Power	120 Vac, 60 Hz	Environmental Conditions	23 °C, 66 % RH
Tested By	Luis Lee		

Antenna Polarity & Test Distance : Horizontal at 3 m								
No	Frequency (MHz)	Emission Level (dBuV/m)	Limit (dBuV/m)	Margin (dB)	Antenna Height (m)	Table Angle (Degree)	Raw Value (dBuV)	Correction Factor (dB/m)
1	*5700.00	112.5 PK			2.30 H	110	68.2	44.3
2	*5700.00	102.4 AV			2.30 H	110	58.1	44.3
3	#5725.00	63.4 PK	68.2	-4.8	2.30 H	110	49.7	13.7
4	11400.00	61.6 PK	74.0	-12.4	1.76 H	188	38.0	23.6
5	11400.00	49.7 AV	54.0	-4.3	1.76 H	188	26.1	23.6

Antenna Polarity & Test Distance : Vertical at 3 m								
No	Frequency (MHz)	Emission Level (dBuV/m)	Limit (dBuV/m)	Margin (dB)	Antenna Height (m)	Table Angle (Degree)	Raw Value (dBuV)	Correction Factor (dB/m)
1	*5700.00	119.3 PK			1.67 V	324	75.0	44.3
2	*5700.00	109.4 AV			1.67 V	324	65.1	44.3
3	#5725.00	63.7 PK	68.2	-4.5	1.67 V	324	50.0	13.7
4	11400.00	61.8 PK	74.0	-12.2	2.18 V	192	38.2	23.6
5	11400.00	49.9 AV	54.0	-4.1	2.18 V	192	26.3	23.6

Remarks:

1. Emission Level(dBuV/m) = Raw Value(dBuV) + Correction Factor(dB/m)
2. Correction Factor(dB/m) = Antenna Factor(dB/m) + Cable Factor(dB) – Pre-Amplifier Factor(dB)
3. Margin value = Emission Level – Limit value
4. The other emission levels were very low against the limit.
5. " * " : Fundamental frequency, the limit was restricted at the RF Output Power.
6. " # " : The radiated frequency is out of the restricted band.



RF Mode	802.11a	Channel	CH 144 : 5720 MHz
Frequency Range	1 GHz ~ 40 GHz	Detector Function & Bandwidth	PK: RB=1 MHz, VB=3 MHz, DET=Peak AV: RB=1 MHz, VB=10 Hz, DET=Peak
Input Power	120 Vac, 60 Hz	Environmental Conditions	23 °C, 66 % RH
Tested By	Luis Lee		

Antenna Polarity & Test Distance : Horizontal at 3 m

No	Frequency (MHz)	Emission Level (dBuV/m)	Limit (dBuV/m)	Margin (dB)	Antenna Height (m)	Table Angle (Degree)	Raw Value (dBuV)	Correction Factor (dB/m)
1	#5470.00	62.1 PK	68.2	-6.1	2.24 H	80	48.8	13.3
2	*5720.00	112.4 PK			2.24 H	80	68.0	44.4
3	*5720.00	102.5 AV			2.24 H	80	58.1	44.4
4	#5850.00	61.8 PK	68.2	-6.4	2.24 H	80	48.0	13.8
5	11440.00	61.5 PK	74.0	-12.5	1.79 H	187	38.0	23.5
6	11440.00	49.3 AV	54.0	-4.7	1.79 H	187	25.8	23.5

Antenna Polarity & Test Distance : Vertical at 3 m

No	Frequency (MHz)	Emission Level (dBuV/m)	Limit (dBuV/m)	Margin (dB)	Antenna Height (m)	Table Angle (Degree)	Raw Value (dBuV)	Correction Factor (dB/m)
1	#5470.00	62.3 PK	68.2	-5.9	1.67 V	322	49.0	13.3
2	*5720.00	118.7 PK			1.67 V	322	74.3	44.4
3	*5720.00	108.9 AV			1.67 V	322	64.5	44.4
4	#5850.00	62.0 PK	68.2	-6.2	1.67 V	322	48.2	13.8
5	11440.00	61.7 PK	74.0	-12.3	2.13 V	192	38.2	23.5
6	11440.00	49.6 AV	54.0	-4.4	2.13 V	192	26.1	23.5

Remarks:

1. Emission Level(dBuV/m) = Raw Value(dBuV) + Correction Factor(dB/m)
2. Correction Factor(dB/m) = Antenna Factor(dB/m) + Cable Factor(dB) – Pre-Amplifier Factor(dB)
3. Margin value = Emission Level – Limit value
4. The other emission levels were very low against the limit.
5. " * " : Fundamental frequency, the limit was restricted at the RF Output Power.
6. " # " : The radiated frequency is out of the restricted band.



RF Mode	802.11a	Channel	CH 149 : 5745 MHz
Frequency Range	1 GHz ~ 40 GHz	Detector Function & Bandwidth	PK: RB=1 MHz, VB=3 MHz, DET=Peak AV: RB=1 MHz, VB=10 Hz, DET=Peak
Input Power	120 Vac, 60 Hz	Environmental Conditions	23 °C, 66 % RH
Tested By	TitanHSU		

Antenna Polarity & Test Distance : Horizontal at 3 m

No	Frequency (MHz)	Emission Level (dBuV/m)	Limit (dBuV/m)	Margin (dB)	Antenna Height (m)	Table Angle (Degree)	Raw Value (dBuV)	Correction Factor (dB/m)
1	#5626.80	60.7 PK	68.2	-7.5	2.36 H	110	47.5	13.2
2	*5745.00	117.7 PK			2.36 H	110	73.1	44.6
3	*5745.00	107.8 AV			2.36 H	110	63.2	44.6
4	#5948.00	60.4 PK	68.2	-7.8	2.36 H	110	46.4	14.0
5	11490.00	63.0 PK	74.0	-11.0	1.75 H	195	39.6	23.4
6	11490.00	49.4 AV	54.0	-4.6	1.75 H	195	26.0	23.4

Antenna Polarity & Test Distance : Vertical at 3 m

No	Frequency (MHz)	Emission Level (dBuV/m)	Limit (dBuV/m)	Margin (dB)	Antenna Height (m)	Table Angle (Degree)	Raw Value (dBuV)	Correction Factor (dB/m)
1	#5605.20	61.2 PK	68.2	-7.0	1.47 V	323	48.1	13.1
2	*5745.00	124.1 PK			1.47 V	323	79.5	44.6
3	*5745.00	114.3 AV			1.47 V	323	69.7	44.6
4	#5931.60	60.8 PK	68.2	-7.4	1.47 V	323	46.8	14.0
5	11490.00	63.5 PK	74.0	-10.5	2.25 V	199	40.1	23.4
6	11490.00	49.8 AV	54.0	-4.2	2.25 V	199	26.4	23.4

Remarks:

1. Emission Level(dBuV/m) = Raw Value(dBuV) + Correction Factor(dB/m)
2. Correction Factor(dB/m) = Antenna Factor(dB/m) + Cable Factor(dB) – Pre-Amplifier Factor(dB)
3. Margin value = Emission Level – Limit value
4. The other emission levels were very low against the limit.
5. " * ": Fundamental frequency, the limit was restricted at the RF Output Power.



RF Mode	802.11a	Channel	CH 157 : 5785 MHz
Frequency Range	1 GHz ~ 40 GHz	Detector Function & Bandwidth	PK: RB=1 MHz, VB=3 MHz, DET=Peak AV: RB=1 MHz, VB=10 Hz, DET=Peak
Input Power	120 Vac, 60 Hz	Environmental Conditions	23 °C, 66 % RH
Tested By	TitanHSU		

Antenna Polarity & Test Distance : Horizontal at 3 m

No	Frequency (MHz)	Emission Level (dBuV/m)	Limit (dBuV/m)	Margin (dB)	Antenna Height (m)	Table Angle (Degree)	Raw Value (dBuV)	Correction Factor (dB/m)
1	#5628.80	60.4 PK	68.2	-7.8	2.18 H	110	47.2	13.2
2	*5785.00	116.7 PK			2.18 H	110	72.0	44.7
3	*5785.00	107.4 AV			2.18 H	110	62.7	44.7
4	#5930.40	61.4 PK	68.2	-6.8	2.18 H	110	47.4	14.0
5	11570.00	63.1 PK	74.0	-10.9	1.72 H	198	40.0	23.1
6	11570.00	49.0 AV	54.0	-5.0	1.72 H	198	25.9	23.1

Antenna Polarity & Test Distance : Vertical at 3 m

No	Frequency (MHz)	Emission Level (dBuV/m)	Limit (dBuV/m)	Margin (dB)	Antenna Height (m)	Table Angle (Degree)	Raw Value (dBuV)	Correction Factor (dB/m)
1	#5645.20	61.5 PK	68.2	-6.7	1.47 V	323	48.1	13.4
2	*5785.00	124.1 PK			1.47 V	323	79.4	44.7
3	*5785.00	114.6 AV			1.47 V	323	69.9	44.7
4	#5937.20	61.4 PK	68.2	-6.8	1.47 V	323	47.4	14.0
5	11570.00	63.6 PK	74.0	-10.4	2.31 V	195	40.5	23.1
6	11570.00	49.3 AV	54.0	-4.7	2.31 V	195	26.2	23.1

Remarks:

1. Emission Level(dBuV/m) = Raw Value(dBuV) + Correction Factor(dB/m)
2. Correction Factor(dB/m) = Antenna Factor(dB/m) + Cable Factor(dB) – Pre-Amplifier Factor(dB)
3. Margin value = Emission Level – Limit value
4. The other emission levels were very low against the limit.
5. " * " : Fundamental frequency, the limit was restricted at the RF Output Power.
6. " # " : The radiated frequency is out of the restricted band.

RF Mode	802.11a	Channel	CH 165 : 5825 MHz
Frequency Range	1 GHz ~ 40 GHz	Detector Function & Bandwidth	PK: RB=1 MHz, VB=3 MHz, DET=Peak AV: RB=1 MHz, VB=10 Hz, DET=Peak
Input Power	120 Vac, 60 Hz	Environmental Conditions	23 °C, 66 % RH
Tested By	TitanHSU		

Antenna Polarity & Test Distance : Horizontal at 3 m

No	Frequency (MHz)	Emission Level (dBuV/m)	Limit (dBuV/m)	Margin (dB)	Antenna Height (m)	Table Angle (Degree)	Raw Value (dBuV)	Correction Factor (dB/m)
1	#5615.60	60.5 PK	68.2	-7.7	2.25 H	112	47.3	13.2
2	*5825.00	117.3 PK			2.25 H	112	72.6	44.7
3	*5825.00	107.5 AV			2.25 H	112	62.8	44.7
4	#5937.60	61.1 PK	68.2	-7.1	2.25 H	112	47.1	14.0
5	11650.00	62.5 PK	74.0	-11.5	1.70 H	188	39.8	22.7
6	11650.00	48.5 AV	54.0	-5.5	1.70 H	188	25.8	22.7

Antenna Polarity & Test Distance : Vertical at 3 m

No	Frequency (MHz)	Emission Level (dBuV/m)	Limit (dBuV/m)	Margin (dB)	Antenna Height (m)	Table Angle (Degree)	Raw Value (dBuV)	Correction Factor (dB/m)
1	#5647.20	60.7 PK	68.2	-7.5	1.33 V	321	47.3	13.4
2	*5825.00	123.4 PK			1.33 V	321	78.7	44.7
3	*5825.00	113.7 AV			1.33 V	321	69.0	44.7
4	#5938.40	62.1 PK	68.2	-6.1	1.33 V	321	48.1	14.0
5	11650.00	62.7 PK	74.0	-11.3	2.18 V	187	40.0	22.7
6	11650.00	48.8 AV	54.0	-5.2	2.18 V	187	26.1	22.7

Remarks:

1. Emission Level(dBuV/m) = Raw Value(dBuV) + Correction Factor(dB/m)
2. Correction Factor(dB/m) = Antenna Factor(dB/m) + Cable Factor(dB) – Pre-Amplifier Factor(dB)
3. Margin value = Emission Level – Limit value
4. The other emission levels were very low against the limit.
5. " * " : Fundamental frequency, the limit was restricted at the RF Output Power.
6. " # " : The radiated frequency is out of the restricted band.

RF Mode	802.11be (EHT20)	Channel	CH 36 : 5180 MHz
Frequency Range	1 GHz ~ 40 GHz	Detector Function & Bandwidth	PK: RB=1 MHz, VB=3 MHz, DET=Peak AV: RB=1 MHz, VB=10 Hz, DET=Peak
Input Power	120 Vac, 60 Hz	Environmental Conditions	23 °C, 66 % RH
Tested By	Luis Lee		

Antenna Polarity & Test Distance : Horizontal at 3 m								
No	Frequency (MHz)	Emission Level (dBuV/m)	Limit (dBuV/m)	Margin (dB)	Antenna Height (m)	Table Angle (Degree)	Raw Value (dBuV)	Correction Factor (dB/m)
1	5150.00	62.4 PK	74.0	-11.6	1.56 H	99	49.3	13.1
2	5150.00	49.1 AV	54.0	-4.9	1.56 H	99	36.0	13.1
3	*5180.00	117.1 PK			1.56 H	99	73.7	43.4
4	*5180.00	104.6 AV			1.56 H	99	61.2	43.4
5	#10360.00	59.7 PK	68.2	-8.5	1.74 H	185	38.0	21.7
Antenna Polarity & Test Distance : Vertical at 3 m								
No	Frequency (MHz)	Emission Level (dBuV/m)	Limit (dBuV/m)	Margin (dB)	Antenna Height (m)	Table Angle (Degree)	Raw Value (dBuV)	Correction Factor (dB/m)
1	5150.00	67.1 PK	74.0	-6.9	1.46 V	127	54.0	13.1
2	5150.00	53.1 AV	54.0	-0.9	1.46 V	127	40.0	13.1
3	*5180.00	123.8 PK			1.46 V	127	80.4	43.4
4	*5180.00	112.2 AV			1.46 V	127	68.8	43.4
5	#10360.00	60.2 PK	68.2	-8.0	2.28 V	197	38.5	21.7

Remarks:

1. Emission Level(dBuV/m) = Raw Value(dBuV) + Correction Factor(dB/m)
2. Correction Factor(dB/m) = Antenna Factor(dB/m) + Cable Factor(dB) – Pre-Amplifier Factor(dB)
3. Margin value = Emission Level – Limit value
4. The other emission levels were very low against the limit.
5. " * " : Fundamental frequency, the limit was restricted at the RF Output Power.
6. " # " : The radiated frequency is out of the restricted band.

RF Mode	802.11be (EHT20)	Channel	CH 40 : 5200 MHz
Frequency Range	1 GHz ~ 40 GHz	Detector Function & Bandwidth	PK: RB=1 MHz, VB=3 MHz, DET=Peak AV: RB=1 MHz, VB=10 Hz, DET=Peak
Input Power	120 Vac, 60 Hz	Environmental Conditions	23 °C, 66 % RH
Tested By	Luis Lee		

Antenna Polarity & Test Distance : Horizontal at 3 m								
No	Frequency (MHz)	Emission Level (dBuV/m)	Limit (dBuV/m)	Margin (dB)	Antenna Height (m)	Table Angle (Degree)	Raw Value (dBuV)	Correction Factor (dB/m)
1	*5200.00	116.5 PK			1.59 H	97	73.2	43.3
2	*5200.00	105.7 AV			1.59 H	97	62.4	43.3
3	#10400.00	59.8 PK	68.2	-8.4	1.79 H	188	38.0	21.8
Antenna Polarity & Test Distance : Vertical at 3 m								
No	Frequency (MHz)	Emission Level (dBuV/m)	Limit (dBuV/m)	Margin (dB)	Antenna Height (m)	Table Angle (Degree)	Raw Value (dBuV)	Correction Factor (dB/m)
1	*5200.00	124.1 PK			1.62 V	127	80.8	43.3
2	*5200.00	112.6 AV			1.62 V	127	69.3	43.3
3	#10400.00	60.5 PK	68.2	-7.7	2.22 V	185	38.7	21.8

Remarks:

1. Emission Level(dBuV/m) = Raw Value(dBuV) + Correction Factor(dB/m)
2. Correction Factor(dB/m) = Antenna Factor(dB/m) + Cable Factor(dB) – Pre-Amplifier Factor(dB)
3. Margin value = Emission Level – Limit value
4. The other emission levels were very low against the limit.
5. " * ": Fundamental frequency, the limit was restricted at the RF Output Power.
6. " # ": The radiated frequency is out of the restricted band.



RF Mode	802.11be (EHT20)	Channel	CH 48 : 5240 MHz
Frequency Range	1 GHz ~ 40 GHz	Detector Function & Bandwidth	PK: RB=1 MHz, VB=3 MHz, DET=Peak AV: RB=1 MHz, VB=10 Hz, DET=Peak
Input Power	120 Vac, 60 Hz	Environmental Conditions	23 °C, 66 % RH
Tested By	Luis Lee		

Antenna Polarity & Test Distance : Horizontal at 3 m								
No	Frequency (MHz)	Emission Level (dBuV/m)	Limit (dBuV/m)	Margin (dB)	Antenna Height (m)	Table Angle (Degree)	Raw Value (dBuV)	Correction Factor (dB/m)
1	*5240.00	118.8 PK			1.62 H	330	75.6	43.2
2	*5240.00	106.6 AV			1.62 H	330	63.4	43.2
3	5350.00	60.5 PK	74.0	-13.5	1.62 H	330	47.4	13.1
4	5350.00	47.3 AV	54.0	-6.7	1.62 H	330	34.2	13.1
5	#10480.00	60.0 PK	68.2	-8.2	1.79 H	188	38.0	22.0

Antenna Polarity & Test Distance : Vertical at 3 m								
No	Frequency (MHz)	Emission Level (dBuV/m)	Limit (dBuV/m)	Margin (dB)	Antenna Height (m)	Table Angle (Degree)	Raw Value (dBuV)	Correction Factor (dB/m)
1	*5240.00	125.2 PK			1.59 V	126	82.0	43.2
2	*5240.00	113.3 AV			1.59 V	126	70.1	43.2
3	5350.00	60.7 PK	74.0	-13.3	1.59 V	126	47.6	13.1
4	5350.00	47.6 AV	54.0	-6.4	1.59 V	126	34.5	13.1
5	#10480.00	60.7 PK	68.2	-7.5	2.21 V	195	38.7	22.0

Remarks:

1. Emission Level(dBuV/m) = Raw Value(dBuV) + Correction Factor(dB/m)
2. Correction Factor(dB/m) = Antenna Factor(dB/m) + Cable Factor(dB) – Pre-Amplifier Factor(dB)
3. Margin value = Emission Level – Limit value
4. The other emission levels were very low against the limit.
5. " * " : Fundamental frequency, the limit was restricted at the RF Output Power.
6. " # " : The radiated frequency is out of the restricted band.

RF Mode	802.11be (EHT20)	Channel	CH 52 : 5260 MHz
Frequency Range	1 GHz ~ 40 GHz	Detector Function & Bandwidth	PK: RB=1 MHz, VB=3 MHz, DET=Peak AV: RB=1 MHz, VB=10 Hz, DET=Peak
Input Power	120 Vac, 60 Hz	Environmental Conditions	23 °C, 66 % RH
Tested By	Luis Lee		

Antenna Polarity & Test Distance : Horizontal at 3 m								
No	Frequency (MHz)	Emission Level (dBuV/m)	Limit (dBuV/m)	Margin (dB)	Antenna Height (m)	Table Angle (Degree)	Raw Value (dBuV)	Correction Factor (dB/m)
1	5150.00	61.0 PK	74.0	-13.0	1.73 H	331	47.9	13.1
2	5150.00	47.7 AV	54.0	-6.3	1.73 H	331	34.6	13.1
3	*5260.00	112.7 PK			1.73 H	331	69.4	43.3
4	*5260.00	100.6 AV			1.73 H	331	57.3	43.3
5	#10520.00	60.2 PK	68.2	-8.0	1.73 H	188	38.2	22.0

Antenna Polarity & Test Distance : Vertical at 3 m								
No	Frequency (MHz)	Emission Level (dBuV/m)	Limit (dBuV/m)	Margin (dB)	Antenna Height (m)	Table Angle (Degree)	Raw Value (dBuV)	Correction Factor (dB/m)
1	5150.00	61.3 PK	74.0	-12.7	1.68 V	126	48.2	13.1
2	5150.00	48.1 AV	54.0	-5.9	1.68 V	126	35.0	13.1
3	*5260.00	118.8 PK			1.68 V	126	75.5	43.3
4	*5260.00	106.9 AV			1.68 V	126	63.6	43.3
5	#10520.00	60.6 PK	68.2	-7.6	2.16 V	186	38.6	22.0

Remarks:

1. Emission Level(dBuV/m) = Raw Value(dBuV) + Correction Factor(dB/m)
2. Correction Factor(dB/m) = Antenna Factor(dB/m) + Cable Factor(dB) – Pre-Amplifier Factor(dB)
3. Margin value = Emission Level – Limit value
4. The other emission levels were very low against the limit.
5. " * ": Fundamental frequency, the limit was restricted at the RF Output Power.
6. " # ": The radiated frequency is out of the restricted band.



RF Mode	802.11be (EHT20)	Channel	CH 60 : 5300 MHz
Frequency Range	1 GHz ~ 40 GHz	Detector Function & Bandwidth	PK: RB=1 MHz, VB=3 MHz, DET=Peak AV: RB=1 MHz, VB=10 Hz, DET=Peak
Input Power	120 Vac, 60 Hz	Environmental Conditions	23 °C, 66 % RH
Tested By	Luis Lee		

Antenna Polarity & Test Distance : Horizontal at 3 m								
No	Frequency (MHz)	Emission Level (dBuV/m)	Limit (dBuV/m)	Margin (dB)	Antenna Height (m)	Table Angle (Degree)	Raw Value (dBuV)	Correction Factor (dB/m)
1	*5300.00	112.5 PK			1.74 H	330	69.2	43.3
2	*5300.00	100.3 AV			1.74 H	330	57.0	43.3
3	10600.00	60.2 PK	74.0	-13.8	1.69 H	189	38.1	22.1
4	10600.00	47.5 AV	54.0	-6.5	1.69 H	189	25.4	22.1

Antenna Polarity & Test Distance : Vertical at 3 m								
No	Frequency (MHz)	Emission Level (dBuV/m)	Limit (dBuV/m)	Margin (dB)	Antenna Height (m)	Table Angle (Degree)	Raw Value (dBuV)	Correction Factor (dB/m)
1	*5300.00	118.6 PK			1.49 V	127	75.3	43.3
2	*5300.00	106.4 AV			1.49 V	127	63.1	43.3
3	10600.00	60.6 PK	74.0	-13.4	2.21 V	188	38.5	22.1
4	10600.00	47.9 AV	54.0	-6.1	2.21 V	188	25.8	22.1

Remarks:

1. Emission Level(dBuV/m) = Raw Value(dBuV) + Correction Factor(dB/m)
2. Correction Factor(dB/m) = Antenna Factor(dB/m) + Cable Factor(dB) – Pre-Amplifier Factor(dB)
3. Margin value = Emission Level – Limit value
4. The other emission levels were very low against the limit.
5. " * " : Fundamental frequency, the limit was restricted at the RF Output Power.



RF Mode	802.11be (EHT20)	Channel	CH 64 : 5320 MHz
Frequency Range	1 GHz ~ 40 GHz	Detector Function & Bandwidth	PK: RB=1 MHz, VB=3 MHz, DET=Peak AV: RB=1 MHz, VB=10 Hz, DET=Peak
Input Power	120 Vac, 60 Hz	Environmental Conditions	23 °C, 66 % RH
Tested By	Luis Lee		

Antenna Polarity & Test Distance : Horizontal at 3 m

No	Frequency (MHz)	Emission Level (dBuV/m)	Limit (dBuV/m)	Margin (dB)	Antenna Height (m)	Table Angle (Degree)	Raw Value (dBuV)	Correction Factor (dB/m)
1	*5320.00	111.7 PK			1.71 H	335	68.2	43.5
2	*5320.00	99.7 AV			1.71 H	335	56.2	43.5
3	5350.00	60.6 PK	74.0	-13.4	1.71 H	335	47.5	13.1
4	5350.00	47.8 AV	54.0	-6.2	1.71 H	335	34.7	13.1
5	10640.00	60.7 PK	74.0	-13.3	1.79 H	188	38.2	22.5
6	10640.00	47.8 AV	54.0	-6.2	1.79 H	188	25.3	22.5

Antenna Polarity & Test Distance : Vertical at 3 m

No	Frequency (MHz)	Emission Level (dBuV/m)	Limit (dBuV/m)	Margin (dB)	Antenna Height (m)	Table Angle (Degree)	Raw Value (dBuV)	Correction Factor (dB/m)
1	*5320.00	118.7 PK			1.42 V	128	75.2	43.5
2	*5320.00	107.2 AV			1.42 V	128	63.7	43.5
3	5350.00	60.9 PK	74.0	-13.1	1.42 V	128	47.8	13.1
4	5350.00	48.1 AV	54.0	-5.9	1.42 V	128	35.0	13.1
5	10640.00	61.0 PK	74.0	-13.0	2.20 V	189	38.5	22.5
6	10640.00	48.2 AV	54.0	-5.8	2.20 V	189	25.7	22.5

Remarks:

1. Emission Level(dBuV/m) = Raw Value(dBuV) + Correction Factor(dB/m)
2. Correction Factor(dB/m) = Antenna Factor(dB/m) + Cable Factor(dB) – Pre-Amplifier Factor(dB)
3. Margin value = Emission Level – Limit value
4. The other emission levels were very low against the limit.
5. " * ": Fundamental frequency, the limit was restricted at the RF Output Power.



RF Mode	802.11be (EHT20)	Channel	CH 100 : 5500 MHz
Frequency Range	1 GHz ~ 40 GHz	Detector Function & Bandwidth	PK: RB=1 MHz, VB=3 MHz, DET=Peak AV: RB=1 MHz, VB=10 Hz, DET=Peak
Input Power	120 Vac, 60 Hz	Environmental Conditions	23 °C, 66 % RH
Tested By	Luis Lee		

Antenna Polarity & Test Distance : Horizontal at 3 m

No	Frequency (MHz)	Emission Level (dBuV/m)	Limit (dBuV/m)	Margin (dB)	Antenna Height (m)	Table Angle (Degree)	Raw Value (dBuV)	Correction Factor (dB/m)
1	5460.00	61.5 PK	74.0	-12.5	2.74 H	82	48.3	13.2
2	5460.00	48.7 AV	54.0	-5.3	2.74 H	82	35.5	13.2
3	#5470.00	62.5 PK	68.2	-5.7	2.74 H	82	49.2	13.3
4	*5500.00	114.0 PK			2.74 H	82	70.1	43.9
5	*5500.00	101.7 AV			2.74 H	82	57.8	43.9
6	11000.00	60.7 PK	74.0	-13.3	1.77 H	184	38.0	22.7
7	11000.00	48.5 AV	54.0	-5.5	1.77 H	184	25.8	22.7

Antenna Polarity & Test Distance : Vertical at 3 m

No	Frequency (MHz)	Emission Level (dBuV/m)	Limit (dBuV/m)	Margin (dB)	Antenna Height (m)	Table Angle (Degree)	Raw Value (dBuV)	Correction Factor (dB/m)
1	5460.00	61.8 PK	74.0	-12.2	1.52 V	349	48.6	13.2
2	5460.00	48.9 AV	54.0	-5.1	1.52 V	349	35.7	13.2
3	#5470.00	62.8 PK	68.2	-5.4	1.52 V	349	49.5	13.3
4	*5500.00	120.5 PK			1.52 V	349	76.6	43.9
5	*5500.00	107.9 AV			1.52 V	349	64.0	43.9
6	11000.00	60.9 PK	74.0	-13.1	2.33 V	196	38.2	22.7
7	11000.00	48.9 AV	54.0	-5.1	2.33 V	196	26.2	22.7

Remarks:

1. Emission Level(dBuV/m) = Raw Value(dBuV) + Correction Factor(dB/m)
2. Correction Factor(dB/m) = Antenna Factor(dB/m) + Cable Factor(dB) – Pre-Amplifier Factor(dB)
3. Margin value = Emission Level – Limit value
4. The other emission levels were very low against the limit.
5. " * " : Fundamental frequency, the limit was restricted at the RF Output Power.
6. " # " : The radiated frequency is out of the restricted band.



RF Mode	802.11be (EHT20)	Channel	CH 116 : 5580 MHz
Frequency Range	1 GHz ~ 40 GHz	Detector Function & Bandwidth	PK: RB=1 MHz, VB=3 MHz, DET=Peak AV: RB=1 MHz, VB=10 Hz, DET=Peak
Input Power	120 Vac, 60 Hz	Environmental Conditions	23 °C, 66 % RH
Tested By	Luis Lee		

Antenna Polarity & Test Distance : Horizontal at 3 m

No	Frequency (MHz)	Emission Level (dBuV/m)	Limit (dBuV/m)	Margin (dB)	Antenna Height (m)	Table Angle (Degree)	Raw Value (dBuV)	Correction Factor (dB/m)
1	*5580.00	114.4 PK			2.79 H	85	70.6	43.8
2	*5580.00	101.3 AV			2.79 H	85	57.5	43.8
3	11160.00	60.8 PK	74.0	-13.2	1.76 H	184	38.0	22.8
4	11160.00	48.6 AV	54.0	-5.4	1.76 H	184	25.8	22.8

Antenna Polarity & Test Distance : Vertical at 3 m

No	Frequency (MHz)	Emission Level (dBuV/m)	Limit (dBuV/m)	Margin (dB)	Antenna Height (m)	Table Angle (Degree)	Raw Value (dBuV)	Correction Factor (dB/m)
1	*5580.00	120.8 PK			1.52 V	345	77.0	43.8
2	*5580.00	108.0 AV			1.52 V	345	64.2	43.8
3	11160.00	60.9 PK	74.0	-13.1	2.18 V	200	38.1	22.8
4	11160.00	48.9 AV	54.0	-5.1	2.18 V	200	26.1	22.8

Remarks:

1. Emission Level(dBuV/m) = Raw Value(dBuV) + Correction Factor(dB/m)
2. Correction Factor(dB/m) = Antenna Factor(dB/m) + Cable Factor(dB) – Pre-Amplifier Factor(dB)
3. Margin value = Emission Level – Limit value
4. The other emission levels were very low against the limit.
5. " * " : Fundamental frequency, the limit was restricted at the RF Output Power.

RF Mode	802.11be (EHT20)	Channel	CH 140 : 5700 MHz
Frequency Range	1 GHz ~ 40 GHz	Detector Function & Bandwidth	PK: RB=1 MHz, VB=3 MHz, DET=Peak AV: RB=1 MHz, VB=10 Hz, DET=Peak
Input Power	120 Vac, 60 Hz	Environmental Conditions	23 °C, 66 % RH
Tested By	Luis Lee		

Antenna Polarity & Test Distance : Horizontal at 3 m

No	Frequency (MHz)	Emission Level (dBuV/m)	Limit (dBuV/m)	Margin (dB)	Antenna Height (m)	Table Angle (Degree)	Raw Value (dBuV)	Correction Factor (dB/m)
1	*5700.00	112.8 PK			2.13 H	87	68.5	44.3
2	*5700.00	100.6 AV			2.13 H	87	56.3	44.3
3	#5725.00	62.8 PK	68.2	-5.4	2.13 H	87	49.1	13.7
4	11400.00	61.6 PK	74.0	-12.4	1.74 H	185	38.0	23.6
5	11400.00	49.5 AV	54.0	-4.5	1.74 H	185	25.9	23.6

Antenna Polarity & Test Distance : Vertical at 3 m

No	Frequency (MHz)	Emission Level (dBuV/m)	Limit (dBuV/m)	Margin (dB)	Antenna Height (m)	Table Angle (Degree)	Raw Value (dBuV)	Correction Factor (dB/m)
1	*5700.00	121.1 PK			1.64 V	327	76.8	44.3
2	*5700.00	108.6 AV			1.64 V	327	64.3	44.3
3	#5725.00	63.2 PK	68.2	-5.0	1.64 V	327	49.5	13.7
4	11400.00	61.8 PK	74.0	-12.2	2.28 V	199	38.2	23.6
5	11400.00	49.7 AV	54.0	-4.3	2.28 V	199	26.1	23.6

Remarks:

1. Emission Level(dBuV/m) = Raw Value(dBuV) + Correction Factor(dB/m)
2. Correction Factor(dB/m) = Antenna Factor(dB/m) + Cable Factor(dB) – Pre-Amplifier Factor(dB)
3. Margin value = Emission Level – Limit value
4. The other emission levels were very low against the limit.
5. " * " : Fundamental frequency, the limit was restricted at the RF Output Power.
6. " # " : The radiated frequency is out of the restricted band.



RF Mode	802.11be (EHT20)	Channel	CH 144 : 5720 MHz
Frequency Range	1 GHz ~ 40 GHz	Detector Function & Bandwidth	PK: RB=1 MHz, VB=3 MHz, DET=Peak AV: RB=1 MHz, VB=10 Hz, DET=Peak
Input Power	120 Vac, 60 Hz	Environmental Conditions	23 °C, 66 % RH
Tested By	Luis Lee		

Antenna Polarity & Test Distance : Horizontal at 3 m

No	Frequency (MHz)	Emission Level (dBuV/m)	Limit (dBuV/m)	Margin (dB)	Antenna Height (m)	Table Angle (Degree)	Raw Value (dBuV)	Correction Factor (dB/m)
1	#5470.00	62.1 PK	68.2	-6.1	2.34 H	86	48.8	13.3
2	*5720.00	113.2 PK			2.34 H	86	68.8	44.4
3	*5720.00	100.3 AV			2.34 H	86	55.9	44.4
4	#5850.00	61.8 PK	68.2	-6.4	2.34 H	86	48.0	13.8
5	11440.00	61.1 PK	74.0	-12.9	1.77 H	180	37.6	23.5
6	11440.00	49.3 AV	54.0	-4.7	1.77 H	180	25.8	23.5

Antenna Polarity & Test Distance : Vertical at 3 m

No	Frequency (MHz)	Emission Level (dBuV/m)	Limit (dBuV/m)	Margin (dB)	Antenna Height (m)	Table Angle (Degree)	Raw Value (dBuV)	Correction Factor (dB/m)
1	#5470.00	62.5 PK	68.2	-5.7	1.64 V	329	49.2	13.3
2	*5720.00	120.6 PK			1.64 V	329	76.2	44.4
3	*5720.00	108.4 AV			1.64 V	329	64.0	44.4
4	#5850.00	62.1 PK	68.2	-6.1	1.64 V	329	48.3	13.8
5	11440.00	61.5 PK	74.0	-12.5	2.23 V	199	38.0	23.5
6	11440.00	49.5 AV	54.0	-4.5	2.23 V	199	26.0	23.5

Remarks:

1. Emission Level(dBuV/m) = Raw Value(dBuV) + Correction Factor(dB/m)
2. Correction Factor(dB/m) = Antenna Factor(dB/m) + Cable Factor(dB) – Pre-Amplifier Factor(dB)
3. Margin value = Emission Level – Limit value
4. The other emission levels were very low against the limit.
5. " * " : Fundamental frequency, the limit was restricted at the RF Output Power.
6. " # " : The radiated frequency is out of the restricted band.



RF Mode	802.11be (EHT20)	Channel	CH 149 : 5745 MHz
Frequency Range	1 GHz ~ 40 GHz	Detector Function & Bandwidth	PK: RB=1 MHz, VB=3 MHz, DET=Peak AV: RB=1 MHz, VB=10 Hz, DET=Peak
Input Power	120 Vac, 60 Hz	Environmental Conditions	23 °C, 66 % RH
Tested By	TitanHSU		

Antenna Polarity & Test Distance : Horizontal at 3 m

No	Frequency (MHz)	Emission Level (dBuV/m)	Limit (dBuV/m)	Margin (dB)	Antenna Height (m)	Table Angle (Degree)	Raw Value (dBuV)	Correction Factor (dB/m)
1	#5606.00	60.6 PK	68.2	-7.6	2.22 H	87	47.5	13.1
2	*5745.00	118.1 PK			2.22 H	87	73.5	44.6
3	*5745.00	106.4 AV			2.22 H	87	61.8	44.6
4	#5960.40	61.5 PK	68.2	-6.7	2.22 H	87	47.6	13.9
5	11490.00	63.4 PK	74.0	-10.6	1.73 H	195	40.0	23.4
6	11490.00	49.4 AV	54.0	-4.6	1.73 H	195	26.0	23.4

Antenna Polarity & Test Distance : Vertical at 3 m

No	Frequency (MHz)	Emission Level (dBuV/m)	Limit (dBuV/m)	Margin (dB)	Antenna Height (m)	Table Angle (Degree)	Raw Value (dBuV)	Correction Factor (dB/m)
1	#5624.80	62.0 PK	68.2	-6.2	1.25 V	326	48.8	13.2
2	*5745.00	126.7 PK			1.25 V	326	82.1	44.6
3	*5745.00	114.1 AV			1.25 V	326	69.5	44.6
4	#5934.40	61.5 PK	68.2	-6.7	1.25 V	326	47.5	14.0
5	11490.00	63.8 PK	74.0	-10.2	2.17 V	195	40.4	23.4
6	11490.00	49.7 AV	54.0	-4.3	2.17 V	195	26.3	23.4

Remarks:

1. Emission Level(dBuV/m) = Raw Value(dBuV) + Correction Factor(dB/m)
2. Correction Factor(dB/m) = Antenna Factor(dB/m) + Cable Factor(dB) – Pre-Amplifier Factor(dB)
3. Margin value = Emission Level – Limit value
4. The other emission levels were very low against the limit.
5. " * " : Fundamental frequency, the limit was restricted at the RF Output Power.
6. " # " : The radiated frequency is out of the restricted band.



RF Mode	802.11be (EHT20)	Channel	CH 157 : 5785 MHz
Frequency Range	1 GHz ~ 40 GHz	Detector Function & Bandwidth	PK: RB=1 MHz, VB=3 MHz, DET=Peak AV: RB=1 MHz, VB=10 Hz, DET=Peak
Input Power	120 Vac, 60 Hz	Environmental Conditions	23 °C, 66 % RH
Tested By	TitanHSU		

Antenna Polarity & Test Distance : Horizontal at 3 m

No	Frequency (MHz)	Emission Level (dBuV/m)	Limit (dBuV/m)	Margin (dB)	Antenna Height (m)	Table Angle (Degree)	Raw Value (dBuV)	Correction Factor (dB/m)
1	#5623.20	60.5 PK	68.2	-7.7	2.16 H	87	47.3	13.2
2	*5785.00	117.9 PK			2.16 H	87	73.2	44.7
3	*5785.00	106.1 AV			2.16 H	87	61.4	44.7
4	#5957.20	60.6 PK	68.2	-7.6	2.16 H	87	46.6	14.0
5	11570.00	63.1 PK	74.0	-10.9	1.80 H	198	40.0	23.1
6	11570.00	49.1 AV	54.0	-4.9	1.80 H	198	26.0	23.1

Antenna Polarity & Test Distance : Vertical at 3 m

No	Frequency (MHz)	Emission Level (dBuV/m)	Limit (dBuV/m)	Margin (dB)	Antenna Height (m)	Table Angle (Degree)	Raw Value (dBuV)	Correction Factor (dB/m)
1	#5605.60	61.0 PK	68.2	-7.2	1.29 V	328	47.9	13.1
2	*5785.00	126.6 PK			1.29 V	328	81.9	44.7
3	*5785.00	114.6 AV			1.29 V	328	69.9	44.7
4	#5963.20	61.2 PK	68.2	-7.0	1.29 V	328	47.2	14.0
5	11570.00	63.3 PK	74.0	-10.7	2.19 V	198	40.2	23.1
6	11570.00	49.5 AV	54.0	-4.5	2.19 V	198	26.4	23.1

Remarks:

1. Emission Level(dBuV/m) = Raw Value(dBuV) + Correction Factor(dB/m)
2. Correction Factor(dB/m) = Antenna Factor(dB/m) + Cable Factor(dB) – Pre-Amplifier Factor(dB)
3. Margin value = Emission Level – Limit value
4. The other emission levels were very low against the limit.
5. " * " : Fundamental frequency, the limit was restricted at the RF Output Power.
6. " # " : The radiated frequency is out of the restricted band.



RF Mode	802.11be (EHT20)	Channel	CH 165 : 5825 MHz
Frequency Range	1 GHz ~ 40 GHz	Detector Function & Bandwidth	PK: RB=1 MHz, VB=3 MHz, DET=Peak AV: RB=1 MHz, VB=10 Hz, DET=Peak
Input Power	120 Vac, 60 Hz	Environmental Conditions	23 °C, 66 % RH
Tested By	TitanHSU		

Antenna Polarity & Test Distance : Horizontal at 3 m

No	Frequency (MHz)	Emission Level (dBuV/m)	Limit (dBuV/m)	Margin (dB)	Antenna Height (m)	Table Angle (Degree)	Raw Value (dBuV)	Correction Factor (dB/m)
1	#5627.20	61.0 PK	68.2	-7.2	2.29 H	148	47.8	13.2
2	*5825.00	118.2 PK			2.29 H	148	73.5	44.7
3	*5825.00	106.3 AV			2.29 H	148	61.6	44.7
4	#5949.20	61.2 PK	68.2	-7.0	2.29 H	148	47.2	14.0
5	11650.00	62.5 PK	74.0	-11.5	1.70 H	189	39.8	22.7
6	11650.00	48.6 AV	54.0	-5.4	1.70 H	189	25.9	22.7

Antenna Polarity & Test Distance : Vertical at 3 m

No	Frequency (MHz)	Emission Level (dBuV/m)	Limit (dBuV/m)	Margin (dB)	Antenna Height (m)	Table Angle (Degree)	Raw Value (dBuV)	Correction Factor (dB/m)
1	#5645.20	61.5 PK	68.2	-6.7	1.29 V	327	48.1	13.4
2	*5825.00	126.0 PK			1.29 V	327	81.3	44.7
3	*5825.00	114.5 AV			1.29 V	327	69.8	44.7
4	#5947.60	61.4 PK	68.2	-6.8	1.29 V	327	47.4	14.0
5	11650.00	62.9 PK	74.0	-11.1	2.18 V	195	40.2	22.7
6	11650.00	48.8 AV	54.0	-5.2	2.18 V	195	26.1	22.7

Remarks:

1. Emission Level(dBuV/m) = Raw Value(dBuV) + Correction Factor(dB/m)
2. Correction Factor(dB/m) = Antenna Factor(dB/m) + Cable Factor(dB) – Pre-Amplifier Factor(dB)
3. Margin value = Emission Level – Limit value
4. The other emission levels were very low against the limit.
5. " * " : Fundamental frequency, the limit was restricted at the RF Output Power.
6. " # " : The radiated frequency is out of the restricted band.

RF Mode	802.11be (EHT40)	Channel	CH 38 : 5190 MHz
Frequency Range	1 GHz ~ 40 GHz	Detector Function & Bandwidth	PK: RB=1 MHz, VB=3 MHz, DET=Peak AV: RB=1 MHz, VB=10 Hz, DET=Peak
Input Power	120 Vac, 60 Hz	Environmental Conditions	23 °C, 66 % RH
Tested By	Luis Lee		

Antenna Polarity & Test Distance : Horizontal at 3 m								
No	Frequency (MHz)	Emission Level (dBuV/m)	Limit (dBuV/m)	Margin (dB)	Antenna Height (m)	Table Angle (Degree)	Raw Value (dBuV)	Correction Factor (dB/m)
1	5150.00	62.6 PK	74.0	-11.4	1.78 H	332	49.5	13.1
2	5150.00	48.7 AV	54.0	-5.3	1.78 H	332	35.6	13.1
3	*5190.00	113.3 PK			1.78 H	332	70.0	43.3
4	*5190.00	101.3 AV			1.78 H	332	58.0	43.3
5	#10380.00	59.7 PK	68.2	-8.5	1.78 H	181	38.0	21.7
Antenna Polarity & Test Distance : Vertical at 3 m								
No	Frequency (MHz)	Emission Level (dBuV/m)	Limit (dBuV/m)	Margin (dB)	Antenna Height (m)	Table Angle (Degree)	Raw Value (dBuV)	Correction Factor (dB/m)
1	5150.00	66.9 PK	74.0	-7.1	1.48 V	125	53.8	13.1
2	5150.00	53.3 AV	54.0	-0.7	1.48 V	125	40.2	13.1
3	*5190.00	119.9 PK			1.48 V	125	76.6	43.3
4	*5190.00	107.3 AV			1.48 V	125	64.0	43.3
5	#10380.00	60.2 PK	68.2	-8.0	2.18 V	192	38.5	21.7

Remarks:

1. Emission Level(dBuV/m) = Raw Value(dBuV) + Correction Factor(dB/m)
2. Correction Factor(dB/m) = Antenna Factor(dB/m) + Cable Factor(dB) – Pre-Amplifier Factor(dB)
3. Margin value = Emission Level – Limit value
4. The other emission levels were very low against the limit.
5. " * " : Fundamental frequency, the limit was restricted at the RF Output Power.
6. " # " : The radiated frequency is out of the restricted band.



RF Mode	802.11be (EHT40)	Channel	CH 46 : 5230 MHz
Frequency Range	1 GHz ~ 40 GHz	Detector Function & Bandwidth	PK: RB=1 MHz, VB=3 MHz, DET=Peak AV: RB=1 MHz, VB=10 Hz, DET=Peak
Input Power	120 Vac, 60 Hz	Environmental Conditions	23 °C, 66 % RH
Tested By	Luis Lee		

Antenna Polarity & Test Distance : Horizontal at 3 m

No	Frequency (MHz)	Emission Level (dBuV/m)	Limit (dBuV/m)	Margin (dB)	Antenna Height (m)	Table Angle (Degree)	Raw Value (dBuV)	Correction Factor (dB/m)
1	5150.00	65.3 PK	74.0	-8.7	1.75 H	332	52.2	13.1
2	5150.00	47.9 AV	54.0	-6.1	1.75 H	332	34.8	13.1
3	*5230.00	116.9 PK			1.75 H	332	73.7	43.2
4	*5230.00	104.2 AV			1.75 H	332	61.0	43.2
5	5350.00	62.0 PK	74.0	-12.0	1.75 H	332	48.9	13.1
6	5350.00	47.9 AV	54.0	-6.1	1.75 H	332	34.8	13.1
7	#10460.00	60.0 PK	68.2	-8.2	1.77 H	189	38.1	21.9

Antenna Polarity & Test Distance : Vertical at 3 m

No	Frequency (MHz)	Emission Level (dBuV/m)	Limit (dBuV/m)	Margin (dB)	Antenna Height (m)	Table Angle (Degree)	Raw Value (dBuV)	Correction Factor (dB/m)
1	5150.00	73.7 PK	74.0	-0.3	1.45 V	125	60.6	13.1
2	5150.00	50.9 AV	54.0	-3.1	1.45 V	125	37.8	13.1
3	*5230.00	123.5 PK			1.45 V	125	80.3	43.2
4	*5230.00	110.7 AV			1.45 V	125	67.5	43.2
5	5350.00	61.6 PK	74.0	-12.4	1.45 V	125	48.5	13.1
6	5350.00	47.7 AV	54.0	-6.3	1.45 V	125	34.6	13.1
7	#10460.00	60.5 PK	68.2	-7.7	2.25 V	188	38.6	21.9

Remarks:

1. Emission Level(dBuV/m) = Raw Value(dBuV) + Correction Factor(dB/m)
2. Correction Factor(dB/m) = Antenna Factor(dB/m) + Cable Factor(dB) – Pre-Amplifier Factor(dB)
3. Margin value = Emission Level – Limit value
4. The other emission levels were very low against the limit.
5. " * " : Fundamental frequency, the limit was restricted at the RF Output Power.
6. " # " : The radiated frequency is out of the restricted band.



RF Mode	802.11be (EHT40)	Channel	CH 54 : 5270 MHz
Frequency Range	1 GHz ~ 40 GHz	Detector Function & Bandwidth	PK: RB=1 MHz, VB=3 MHz, DET=Peak AV: RB=1 MHz, VB=10 Hz, DET=Peak
Input Power	120 Vac, 60 Hz	Environmental Conditions	23 °C, 66 % RH
Tested By	Luis Lee		

Antenna Polarity & Test Distance : Horizontal at 3 m

No	Frequency (MHz)	Emission Level (dBuV/m)	Limit (dBuV/m)	Margin (dB)	Antenna Height (m)	Table Angle (Degree)	Raw Value (dBuV)	Correction Factor (dB/m)
1	5150.00	60.5 PK	74.0	-13.5	1.71 H	331	47.4	13.1
2	5150.00	47.4 AV	54.0	-6.6	1.71 H	331	34.3	13.1
3	*5270.00	110.5 PK			1.71 H	331	67.2	43.3
4	*5270.00	98.2 AV			1.71 H	331	54.9	43.3
5	#10540.00	60.2 PK	68.2	-8.0	1.73 H	180	38.1	22.1

Antenna Polarity & Test Distance : Vertical at 3 m

No	Frequency (MHz)	Emission Level (dBuV/m)	Limit (dBuV/m)	Margin (dB)	Antenna Height (m)	Table Angle (Degree)	Raw Value (dBuV)	Correction Factor (dB/m)
1	5150.00	60.7 PK	74.0	-13.3	1.44 V	127	47.6	13.1
2	5150.00	47.7 AV	54.0	-6.3	1.44 V	127	34.6	13.1
3	*5270.00	116.9 PK			1.44 V	127	73.6	43.3
4	*5270.00	104.3 AV			1.44 V	127	61.0	43.3
5	#10540.00	60.5 PK	68.2	-7.7	2.12 V	186	38.4	22.1

Remarks:

1. Emission Level(dBuV/m) = Raw Value(dBuV) + Correction Factor(dB/m)
2. Correction Factor(dB/m) = Antenna Factor(dB/m) + Cable Factor(dB) – Pre-Amplifier Factor(dB)
3. Margin value = Emission Level – Limit value
4. The other emission levels were very low against the limit.
5. " * ": Fundamental frequency, the limit was restricted at the RF Output Power.
6. " # ": The radiated frequency is out of the restricted band.



RF Mode	802.11be (EHT40)	Channel	CH 62 : 5310 MHz
Frequency Range	1 GHz ~ 40 GHz	Detector Function & Bandwidth	PK: RB=1 MHz, VB=3 MHz, DET=Peak AV: RB=1 MHz, VB=10 Hz, DET=Peak
Input Power	120 Vac, 60 Hz	Environmental Conditions	23 °C, 66 % RH
Tested By	Luis Lee		

Antenna Polarity & Test Distance : Horizontal at 3 m

No	Frequency (MHz)	Emission Level (dBuV/m)	Limit (dBuV/m)	Margin (dB)	Antenna Height (m)	Table Angle (Degree)	Raw Value (dBuV)	Correction Factor (dB/m)
1	*5310.00	110.0 PK			1.71 H	330	66.7	43.3
2	*5310.00	97.4 AV			1.71 H	330	54.1	43.3
3	5350.00	61.6 PK	74.0	-12.4	1.71 H	330	48.5	13.1
4	5350.00	48.9 AV	54.0	-5.1	1.71 H	330	35.8	13.1
5	10620.00	60.3 PK	74.0	-13.7	1.76 H	190	38.1	22.2
6	10620.00	47.6 AV	54.0	-6.4	1.76 H	190	25.4	22.2

Antenna Polarity & Test Distance : Vertical at 3 m

No	Frequency (MHz)	Emission Level (dBuV/m)	Limit (dBuV/m)	Margin (dB)	Antenna Height (m)	Table Angle (Degree)	Raw Value (dBuV)	Correction Factor (dB/m)
1	*5310.00	116.5 PK			1.45 V	129	73.2	43.3
2	*5310.00	104.1 AV			1.45 V	129	60.8	43.3
3	5350.00	61.9 PK	74.0	-12.1	1.45 V	129	48.8	13.1
4	5350.00	49.3 AV	54.0	-4.7	1.45 V	129	36.2	13.1
5	10620.00	60.7 PK	74.0	-13.3	2.18 V	187	38.5	22.2
6	10620.00	47.8 AV	54.0	-6.2	2.18 V	187	25.6	22.2

Remarks:

1. Emission Level(dBuV/m) = Raw Value(dBuV) + Correction Factor(dB/m)
2. Correction Factor(dB/m) = Antenna Factor(dB/m) + Cable Factor(dB) – Pre-Amplifier Factor(dB)
3. Margin value = Emission Level – Limit value
4. The other emission levels were very low against the limit.
5. " * ": Fundamental frequency, the limit was restricted at the RF Output Power.



RF Mode	802.11be (EHT40)	Channel	CH 102 : 5510 MHz
Frequency Range	1 GHz ~ 40 GHz	Detector Function & Bandwidth	PK: RB=1 MHz, VB=3 MHz, DET=Peak AV: RB=1 MHz, VB=10 Hz, DET=Peak
Input Power	120 Vac, 60 Hz	Environmental Conditions	23 °C, 66 % RH
Tested By	Luis Lee		

Antenna Polarity & Test Distance : Horizontal at 3 m

No	Frequency (MHz)	Emission Level (dBuV/m)	Limit (dBuV/m)	Margin (dB)	Antenna Height (m)	Table Angle (Degree)	Raw Value (dBuV)	Correction Factor (dB/m)
1	5460.00	61.4 PK	74.0	-12.6	2.34 H	87	48.2	13.2
2	5460.00	48.6 AV	54.0	-5.4	2.34 H	87	35.4	13.2
3	#5470.00	62.4 PK	68.2	-5.8	2.34 H	87	49.1	13.3
4	*5510.00	109.5 PK			2.34 H	87	65.6	43.9
5	*5510.00	97.3 AV			2.34 H	87	53.4	43.9
6	11020.00	60.8 PK	74.0	-13.2	1.77 H	184	37.9	22.9
7	11020.00	48.6 AV	54.0	-5.4	1.77 H	184	25.7	22.9

Antenna Polarity & Test Distance : Vertical at 3 m

No	Frequency (MHz)	Emission Level (dBuV/m)	Limit (dBuV/m)	Margin (dB)	Antenna Height (m)	Table Angle (Degree)	Raw Value (dBuV)	Correction Factor (dB/m)
1	5460.00	61.7 PK	74.0	-12.3	1.63 V	347	48.5	13.2
2	5460.00	48.8 AV	54.0	-5.2	1.63 V	347	35.6	13.2
3	#5470.00	62.7 PK	68.2	-5.5	1.63 V	347	49.4	13.3
4	*5510.00	117.4 PK			1.63 V	347	73.5	43.9
5	*5510.00	104.5 AV			1.63 V	347	60.6	43.9
6	11020.00	61.0 PK	74.0	-13.0	2.34 V	195	38.1	22.9
7	11020.00	48.9 AV	54.0	-5.1	2.34 V	195	26.0	22.9

Remarks:

1. Emission Level(dBuV/m) = Raw Value(dBuV) + Correction Factor(dB/m)
2. Correction Factor(dB/m) = Antenna Factor(dB/m) + Cable Factor(dB) – Pre-Amplifier Factor(dB)
3. Margin value = Emission Level – Limit value
4. The other emission levels were very low against the limit.
5. " * " : Fundamental frequency, the limit was restricted at the RF Output Power.
6. " # " : The radiated frequency is out of the restricted band.



RF Mode	802.11be (EHT40)	Channel	CH 110 : 5550 MHz
Frequency Range	1 GHz ~ 40 GHz	Detector Function & Bandwidth	PK: RB=1 MHz, VB=3 MHz, DET=Peak AV: RB=1 MHz, VB=10 Hz, DET=Peak
Input Power	120 Vac, 60 Hz	Environmental Conditions	23 °C, 66 % RH
Tested By	Luis Lee		

Antenna Polarity & Test Distance : Horizontal at 3 m

No	Frequency (MHz)	Emission Level (dBuV/m)	Limit (dBuV/m)	Margin (dB)	Antenna Height (m)	Table Angle (Degree)	Raw Value (dBuV)	Correction Factor (dB/m)
1	*5550.00	109.4 PK			2.39 H	91	65.5	43.9
2	*5550.00	97.3 AV			2.39 H	91	53.4	43.9
3	11100.00	60.8 PK	74.0	-13.2	1.72 H	189	38.0	22.8
4	11100.00	48.9 AV	54.0	-5.1	1.72 H	189	26.1	22.8

Antenna Polarity & Test Distance : Vertical at 3 m

No	Frequency (MHz)	Emission Level (dBuV/m)	Limit (dBuV/m)	Margin (dB)	Antenna Height (m)	Table Angle (Degree)	Raw Value (dBuV)	Correction Factor (dB/m)
1	*5550.00	116.7 PK			1.56 V	348	72.8	43.9
2	*5550.00	104.5 AV			1.56 V	348	60.6	43.9
3	11100.00	61.1 PK	74.0	-12.9	2.34 V	196	38.3	22.8
4	11100.00	49.1 AV	54.0	-4.9	2.34 V	196	26.3	22.8

Remarks:

1. Emission Level(dBuV/m) = Raw Value(dBuV) + Correction Factor(dB/m)
2. Correction Factor(dB/m) = Antenna Factor(dB/m) + Cable Factor(dB) – Pre-Amplifier Factor(dB)
3. Margin value = Emission Level – Limit value
4. The other emission levels were very low against the limit.
5. " * " : Fundamental frequency, the limit was restricted at the RF Output Power.



RF Mode	802.11be (EHT40)	Channel	CH 134 : 5670 MHz
Frequency Range	1 GHz ~ 40 GHz	Detector Function & Bandwidth	PK: RB=1 MHz, VB=3 MHz, DET=Peak AV: RB=1 MHz, VB=10 Hz, DET=Peak
Input Power	120 Vac, 60 Hz	Environmental Conditions	23 °C, 66 % RH
Tested By	Luis Lee		

Antenna Polarity & Test Distance : Horizontal at 3 m

No	Frequency (MHz)	Emission Level (dBuV/m)	Limit (dBuV/m)	Margin (dB)	Antenna Height (m)	Table Angle (Degree)	Raw Value (dBuV)	Correction Factor (dB/m)
1	*5670.00	110.2 PK			2.36 H	86	66.0	44.2
2	*5670.00	97.5 AV			2.36 H	86	53.3	44.2
3	#5725.00	63.4 PK	68.2	-4.8	2.36 H	86	49.7	13.7
4	11340.00	61.4 PK	74.0	-12.6	1.73 H	180	38.1	23.3
5	11340.00	49.0 AV	54.0	-5.0	1.73 H	180	25.7	23.3

Antenna Polarity & Test Distance : Vertical at 3 m

No	Frequency (MHz)	Emission Level (dBuV/m)	Limit (dBuV/m)	Margin (dB)	Antenna Height (m)	Table Angle (Degree)	Raw Value (dBuV)	Correction Factor (dB/m)
1	*5670.00	117.5 PK			1.67 V	350	73.3	44.2
2	*5670.00	104.6 AV			1.67 V	350	60.4	44.2
3	#5725.00	63.8 PK	68.2	-4.4	1.67 V	350	50.1	13.7
4	11340.00	61.6 PK	74.0	-12.4	2.11 V	197	38.3	23.3
5	11340.00	49.3 AV	54.0	-4.7	2.11 V	197	26.0	23.3

Remarks:

1. Emission Level(dBuV/m) = Raw Value(dBuV) + Correction Factor(dB/m)
2. Correction Factor(dB/m) = Antenna Factor(dB/m) + Cable Factor(dB) – Pre-Amplifier Factor(dB)
3. Margin value = Emission Level – Limit value
4. The other emission levels were very low against the limit.
5. " * ": Fundamental frequency, the limit was restricted at the RF Output Power.
6. " # ": The radiated frequency is out of the restricted band.



RF Mode	802.11be (EHT40)	Channel	CH 142 : 5710 MHz
Frequency Range	1 GHz ~ 40 GHz	Detector Function & Bandwidth	PK: RB=1 MHz, VB=3 MHz, DET=Peak AV: RB=1 MHz, VB=10 Hz, DET=Peak
Input Power	120 Vac, 60 Hz	Environmental Conditions	23 °C, 66 % RH
Tested By	Luis Lee		

Antenna Polarity & Test Distance : Horizontal at 3 m

No	Frequency (MHz)	Emission Level (dBuV/m)	Limit (dBuV/m)	Margin (dB)	Antenna Height (m)	Table Angle (Degree)	Raw Value (dBuV)	Correction Factor (dB/m)
1	#5470.00	61.8 PK	68.2	-6.4	2.35 H	85	48.5	13.3
2	*5710.00	110.4 PK			2.35 H	85	66.1	44.3
3	*5710.00	97.5 AV			2.35 H	85	53.2	44.3
4	#5850.00	61.8 PK	68.2	-6.4	2.35 H	85	48.0	13.8
5	11420.00	61.3 PK	74.0	-12.7	1.69 H	188	37.7	23.6
6	11420.00	49.5 AV	54.0	-4.5	1.69 H	188	25.9	23.6

Antenna Polarity & Test Distance : Vertical at 3 m

No	Frequency (MHz)	Emission Level (dBuV/m)	Limit (dBuV/m)	Margin (dB)	Antenna Height (m)	Table Angle (Degree)	Raw Value (dBuV)	Correction Factor (dB/m)
1	#5470.00	62.2 PK	68.2	-6.0	1.48 V	347	48.9	13.3
2	*5710.00	117.3 PK			1.48 V	347	73.0	44.3
3	*5710.00	104.6 AV			1.48 V	347	60.3	44.3
4	#5850.00	62.0 PK	68.2	-6.2	1.48 V	347	48.2	13.8
5	11420.00	61.6 PK	74.0	-12.4	2.18 V	197	38.0	23.6
6	11420.00	49.7 AV	54.0	-4.3	2.18 V	197	26.1	23.6

Remarks:

1. Emission Level(dBuV/m) = Raw Value(dBuV) + Correction Factor(dB/m)
2. Correction Factor(dB/m) = Antenna Factor(dB/m) + Cable Factor(dB) – Pre-Amplifier Factor(dB)
3. Margin value = Emission Level – Limit value
4. The other emission levels were very low against the limit.
5. " * " : Fundamental frequency, the limit was restricted at the RF Output Power.
6. " # " : The radiated frequency is out of the restricted band.



RF Mode	802.11be (EHT40)	Channel	CH 151 : 5755 MHz
Frequency Range	1 GHz ~ 40 GHz	Detector Function & Bandwidth	PK: RB=1 MHz, VB=3 MHz, DET=Peak AV: RB=1 MHz, VB=10 Hz, DET=Peak
Input Power	120 Vac, 60 Hz	Environmental Conditions	23 °C, 66 % RH
Tested By	TitanHSU		

Antenna Polarity & Test Distance : Horizontal at 3 m

No	Frequency (MHz)	Emission Level (dBuV/m)	Limit (dBuV/m)	Margin (dB)	Antenna Height (m)	Table Angle (Degree)	Raw Value (dBuV)	Correction Factor (dB/m)
1	#5642.80	60.6 PK	68.2	-7.6	2.26 H	153	47.2	13.4
2	*5755.00	115.7 PK			2.26 H	153	71.1	44.6
3	*5755.00	103.5 AV			2.26 H	153	58.9	44.6
4	#5998.80	60.5 PK	68.2	-7.7	2.26 H	153	46.4	14.1
5	11510.00	63.0 PK	74.0	-11.0	1.69 H	188	39.7	23.3
6	11510.00	49.3 AV	54.0	-4.7	1.69 H	188	26.0	23.3

Antenna Polarity & Test Distance : Vertical at 3 m

No	Frequency (MHz)	Emission Level (dBuV/m)	Limit (dBuV/m)	Margin (dB)	Antenna Height (m)	Table Angle (Degree)	Raw Value (dBuV)	Correction Factor (dB/m)
1	#5646.00	62.3 PK	68.2	-5.9	1.30 V	327	48.9	13.4
2	*5755.00	123.9 PK			1.30 V	327	79.3	44.6
3	*5755.00	111.6 AV			1.30 V	327	67.0	44.6
4	#5934.40	60.8 PK	68.2	-7.4	1.30 V	327	46.8	14.0
5	11510.00	63.3 PK	74.0	-10.7	2.16 V	197	40.0	23.3
6	11510.00	49.5 AV	54.0	-4.5	2.16 V	197	26.2	23.3

Remarks:

1. Emission Level(dBuV/m) = Raw Value(dBuV) + Correction Factor(dB/m)
2. Correction Factor(dB/m) = Antenna Factor(dB/m) + Cable Factor(dB) – Pre-Amplifier Factor(dB)
3. Margin value = Emission Level – Limit value
4. The other emission levels were very low against the limit.
5. " * " : Fundamental frequency, the limit was restricted at the RF Output Power.
6. " # " : The radiated frequency is out of the restricted band.



RF Mode	802.11be (EHT40)	Channel	CH 159 : 5795 MHz
Frequency Range	1 GHz ~ 40 GHz	Detector Function & Bandwidth	PK: RB=1 MHz, VB=3 MHz, DET=Peak AV: RB=1 MHz, VB=10 Hz, DET=Peak
Input Power	120 Vac, 60 Hz	Environmental Conditions	23 °C, 66 % RH
Tested By	TitanHSU		

Antenna Polarity & Test Distance : Horizontal at 3 m

No	Frequency (MHz)	Emission Level (dBuV/m)	Limit (dBuV/m)	Margin (dB)	Antenna Height (m)	Table Angle (Degree)	Raw Value (dBuV)	Correction Factor (dB/m)
1	#5622.40	60.3 PK	68.2	-7.9	2.26 H	149	47.1	13.2
2	*5795.00	116.1 PK			2.26 H	149	71.4	44.7
3	*5795.00	102.7 AV			2.26 H	149	58.0	44.7
4	#5986.40	61.0 PK	68.2	-7.2	2.26 H	149	47.0	14.0
5	11590.00	62.7 PK	74.0	-11.3	1.72 H	195	39.8	22.9
6	11590.00	49.0 AV	54.0	-5.0	1.72 H	195	26.1	22.9

Antenna Polarity & Test Distance : Vertical at 3 m

No	Frequency (MHz)	Emission Level (dBuV/m)	Limit (dBuV/m)	Margin (dB)	Antenna Height (m)	Table Angle (Degree)	Raw Value (dBuV)	Correction Factor (dB/m)
1	#5644.80	61.7 PK	68.2	-6.5	1.46 V	328	48.3	13.4
2	*5795.00	122.8 PK			1.46 V	328	78.1	44.7
3	*5795.00	111.0 AV			1.46 V	328	66.3	44.7
4	#5976.40	61.1 PK	68.2	-7.1	1.46 V	328	47.1	14.0
5	11590.00	63.1 PK	74.0	-10.9	2.19 V	187	40.2	22.9
6	11590.00	49.4 AV	54.0	-4.6	2.19 V	187	26.5	22.9

Remarks:

1. Emission Level(dBuV/m) = Raw Value(dBuV) + Correction Factor(dB/m)
2. Correction Factor(dB/m) = Antenna Factor(dB/m) + Cable Factor(dB) – Pre-Amplifier Factor(dB)
3. Margin value = Emission Level – Limit value
4. The other emission levels were very low against the limit.
5. " * " : Fundamental frequency, the limit was restricted at the RF Output Power.
6. " # " : The radiated frequency is out of the restricted band.

RF Mode	802.11be (EHT80)	Channel	CH 42 : 5210 MHz
Frequency Range	1 GHz ~ 40 GHz	Detector Function & Bandwidth	PK: RB=1 MHz, VB=3 MHz, DET=Peak AV: RB=1 MHz, VB=10 Hz, DET=Peak
Input Power	120 Vac, 60 Hz	Environmental Conditions	23 °C, 66 % RH
Tested By	Luis Lee		

Antenna Polarity & Test Distance : Horizontal at 3 m

No	Frequency (MHz)	Emission Level (dBuV/m)	Limit (dBuV/m)	Margin (dB)	Antenna Height (m)	Table Angle (Degree)	Raw Value (dBuV)	Correction Factor (dB/m)
1	5150.00	61.2 PK	74.0	-12.8	1.75 H	332	48.1	13.1
2	5150.00	48.6 AV	54.0	-5.4	1.75 H	332	35.5	13.1
3	*5210.00	110.8 PK			1.75 H	332	67.5	43.3
4	*5210.00	98.8 AV			1.75 H	332	55.5	43.3
5	#10420.00	59.8 PK	68.2	-8.4	1.66 H	180	37.9	21.9

Antenna Polarity & Test Distance : Vertical at 3 m

No	Frequency (MHz)	Emission Level (dBuV/m)	Limit (dBuV/m)	Margin (dB)	Antenna Height (m)	Table Angle (Degree)	Raw Value (dBuV)	Correction Factor (dB/m)
1	5150.00	64.6 PK	74.0	-9.4	1.40 V	127	51.5	13.1
2	5150.00	53.3 AV	54.0	-0.7	1.40 V	127	40.2	13.1
3	*5210.00	116.6 PK			1.40 V	127	73.3	43.3
4	*5210.00	104.5 AV			1.40 V	127	61.2	43.3
5	#10420.00	60.4 PK	68.2	-7.8	2.15 V	192	38.5	21.9

Remarks:

1. Emission Level(dBuV/m) = Raw Value(dBuV) + Correction Factor(dB/m)
2. Correction Factor(dB/m) = Antenna Factor(dB/m) + Cable Factor(dB) – Pre-Amplifier Factor(dB)
3. Margin value = Emission Level – Limit value
4. The other emission levels were very low against the limit.
5. " * " : Fundamental frequency, the limit was restricted at the RF Output Power.
6. " # " : The radiated frequency is out of the restricted band.



RF Mode	802.11be (EHT80)	Channel	CH 58 : 5290 MHz
Frequency Range	1 GHz ~ 40 GHz	Detector Function & Bandwidth	PK: RB=1 MHz, VB=3 MHz, DET=Peak AV: RB=1 MHz, VB=10 Hz, DET=Peak
Input Power	120 Vac, 60 Hz	Environmental Conditions	23 °C, 66 % RH
Tested By	Luis Lee		

Antenna Polarity & Test Distance : Horizontal at 3 m

No	Frequency (MHz)	Emission Level (dBuV/m)	Limit (dBuV/m)	Margin (dB)	Antenna Height (m)	Table Angle (Degree)	Raw Value (dBuV)	Correction Factor (dB/m)
1	*5290.00	106.8 PK			1.74 H	331	63.5	43.3
2	*5290.00	94.6 AV			1.74 H	331	51.3	43.3
3	5350.00	62.4 PK	74.0	-11.6	1.74 H	331	49.3	13.1
4	5350.00	49.2 AV	54.0	-4.8	1.74 H	331	36.1	13.1
5	#10580.00	60.1 PK	68.2	-8.1	1.77 H	183	38.0	22.1

Antenna Polarity & Test Distance : Vertical at 3 m

No	Frequency (MHz)	Emission Level (dBuV/m)	Limit (dBuV/m)	Margin (dB)	Antenna Height (m)	Table Angle (Degree)	Raw Value (dBuV)	Correction Factor (dB/m)
1	*5290.00	113.7 PK			1.48 V	129	70.4	43.3
2	*5290.00	101.2 AV			1.48 V	129	57.9	43.3
3	5350.00	62.6 PK	74.0	-11.4	1.48 V	129	49.5	13.1
4	5350.00	49.5 AV	54.0	-4.5	1.48 V	129	36.4	13.1
5	#10580.00	60.5 PK	68.2	-7.7	2.16 V	190	38.4	22.1

Remarks:

1. Emission Level(dBuV/m) = Raw Value(dBuV) + Correction Factor(dB/m)
2. Correction Factor(dB/m) = Antenna Factor(dB/m) + Cable Factor(dB) – Pre-Amplifier Factor(dB)
3. Margin value = Emission Level – Limit value
4. The other emission levels were very low against the limit.
5. " * " : Fundamental frequency, the limit was restricted at the RF Output Power.
6. " # " : The radiated frequency is out of the restricted band.



RF Mode	802.11be (EHT80)	Channel	CH 106 : 5530 MHz
Frequency Range	1 GHz ~ 40 GHz	Detector Function & Bandwidth	PK: RB=1 MHz, VB=3 MHz, DET=Peak AV: RB=1 MHz, VB=10 Hz, DET=Peak
Input Power	120 Vac, 60 Hz	Environmental Conditions	23 °C, 66 % RH
Tested By	Luis Lee		

Antenna Polarity & Test Distance : Horizontal at 3 m

No	Frequency (MHz)	Emission Level (dBuV/m)	Limit (dBuV/m)	Margin (dB)	Antenna Height (m)	Table Angle (Degree)	Raw Value (dBuV)	Correction Factor (dB/m)
1	5460.00	61.8 PK	74.0	-12.2	2.28 H	88	48.6	13.2
2	5460.00	48.6 AV	54.0	-5.4	2.28 H	88	35.4	13.2
3	#5470.00	62.9 PK	68.2	-5.3	2.28 H	88	49.6	13.3
4	*5530.00	107.6 PK			2.28 H	88	63.7	43.9
5	*5530.00	94.8 AV			2.28 H	88	50.9	43.9
6	11060.00	60.6 PK	74.0	-13.4	1.69 H	188	37.8	22.8
7	11060.00	48.6 AV	54.0	-5.4	1.69 H	188	25.8	22.8

Antenna Polarity & Test Distance : Vertical at 3 m

No	Frequency (MHz)	Emission Level (dBuV/m)	Limit (dBuV/m)	Margin (dB)	Antenna Height (m)	Table Angle (Degree)	Raw Value (dBuV)	Correction Factor (dB/m)
1	5460.00	62.0 PK	74.0	-12.0	1.37 V	347	48.8	13.2
2	5460.00	48.8 AV	54.0	-5.2	1.37 V	347	35.6	13.2
3	#5470.00	63.1 PK	68.2	-5.1	1.37 V	347	49.8	13.3
4	*5530.00	114.7 PK			1.37 V	347	70.8	43.9
5	*5530.00	101.8 AV			1.37 V	347	57.9	43.9
6	11060.00	60.8 PK	74.0	-13.2	2.41 V	183	38.0	22.8
7	11060.00	48.9 AV	54.0	-5.1	2.41 V	183	26.1	22.8

Remarks:

1. Emission Level(dBuV/m) = Raw Value(dBuV) + Correction Factor(dB/m)
2. Correction Factor(dB/m) = Antenna Factor(dB/m) + Cable Factor(dB) – Pre-Amplifier Factor(dB)
3. Margin value = Emission Level – Limit value
4. The other emission levels were very low against the limit.
5. " * " : Fundamental frequency, the limit was restricted at the RF Output Power.
6. " # " : The radiated frequency is out of the restricted band.

RF Mode	802.11be (EHT80)	Channel	CH 122 : 5610 MHz
Frequency Range	1 GHz ~ 40 GHz	Detector Function & Bandwidth	PK: RB=1 MHz, VB=3 MHz, DET=Peak AV: RB=1 MHz, VB=10 Hz, DET=Peak
Input Power	120 Vac, 60 Hz	Environmental Conditions	23 °C, 66 % RH
Tested By	Luis Lee		

Antenna Polarity & Test Distance : Horizontal at 3 m								
No	Frequency (MHz)	Emission Level (dBuV/m)	Limit (dBuV/m)	Margin (dB)	Antenna Height (m)	Table Angle (Degree)	Raw Value (dBuV)	Correction Factor (dB/m)
1	*5610.00	107.1 PK			2.27 H	87	63.3	43.8
2	*5610.00	94.8 AV			2.27 H	87	51.0	43.8
3	#5725.00	63.4 PK	68.2	-4.8	2.27 H	87	49.7	13.7
4	11220.00	60.6 PK	74.0	-13.4	1.75 H	189	37.8	22.8
5	11220.00	48.7 AV	54.0	-5.3	1.75 H	189	25.9	22.8

Antenna Polarity & Test Distance : Vertical at 3 m								
No	Frequency (MHz)	Emission Level (dBuV/m)	Limit (dBuV/m)	Margin (dB)	Antenna Height (m)	Table Angle (Degree)	Raw Value (dBuV)	Correction Factor (dB/m)
1	*5610.00	114.3 PK			1.43 V	348	70.5	43.8
2	*5610.00	101.6 AV			1.43 V	348	57.8	43.8
3	#5725.00	63.5 PK	68.2	-4.7	1.43 V	348	49.8	13.7
4	11220.00	60.8 PK	74.0	-13.2	2.22 V	183	38.0	22.8
5	11220.00	48.8 AV	54.0	-5.2	2.22 V	183	26.0	22.8

Remarks:

1. Emission Level(dBuV/m) = Raw Value(dBuV) + Correction Factor(dB/m)
2. Correction Factor(dB/m) = Antenna Factor(dB/m) + Cable Factor(dB) – Pre-Amplifier Factor(dB)
3. Margin value = Emission Level – Limit value
4. The other emission levels were very low against the limit.
5. " * ": Fundamental frequency, the limit was restricted at the RF Output Power.
6. " # ": The radiated frequency is out of the restricted band.

RF Mode	802.11be (EHT80)	Channel	CH 138 : 5690 MHz
Frequency Range	1 GHz ~ 40 GHz	Detector Function & Bandwidth	PK: RB=1 MHz, VB=3 MHz, DET=Peak AV: RB=1 MHz, VB=10 Hz, DET=Peak
Input Power	120 Vac, 60 Hz	Environmental Conditions	23 °C, 66 % RH
Tested By	Luis Lee		

Antenna Polarity & Test Distance : Horizontal at 3 m

No	Frequency (MHz)	Emission Level (dBuV/m)	Limit (dBuV/m)	Margin (dB)	Antenna Height (m)	Table Angle (Degree)	Raw Value (dBuV)	Correction Factor (dB/m)
1	#5470.00	61.9 PK	68.2	-6.3	2.28 H	83	48.6	13.3
2	*5690.00	107.0 PK			2.28 H	83	62.8	44.2
3	*5690.00	94.5 AV			2.28 H	83	50.3	44.2
4	#5850.00	61.8 PK	68.2	-6.4	2.28 H	83	48.0	13.8
5	11380.00	61.1 PK	74.0	-12.9	1.76 H	184	37.7	23.4
6	11380.00	49.2 AV	54.0	-4.8	1.76 H	184	25.8	23.4

Antenna Polarity & Test Distance : Vertical at 3 m

No	Frequency (MHz)	Emission Level (dBuV/m)	Limit (dBuV/m)	Margin (dB)	Antenna Height (m)	Table Angle (Degree)	Raw Value (dBuV)	Correction Factor (dB/m)
1	#5470.00	62.1 PK	68.2	-6.1	1.43 V	349	48.8	13.3
2	*5690.00	114.0 PK			1.43 V	349	69.8	44.2
3	*5690.00	101.6 AV			1.43 V	349	57.4	44.2
4	#5850.00	62.1 PK	68.2	-6.1	1.43 V	349	48.3	13.8
5	11380.00	61.4 PK	74.0	-12.6	2.16 V	192	38.0	23.4
6	11380.00	49.4 AV	54.0	-4.6	2.16 V	192	26.0	23.4

Remarks:

1. Emission Level(dBuV/m) = Raw Value(dBuV) + Correction Factor(dB/m)
2. Correction Factor(dB/m) = Antenna Factor(dB/m) + Cable Factor(dB) – Pre-Amplifier Factor(dB)
3. Margin value = Emission Level – Limit value
4. The other emission levels were very low against the limit.
5. " * " : Fundamental frequency, the limit was restricted at the RF Output Power.
6. " # " : The radiated frequency is out of the restricted band.



RF Mode	802.11be (EHT80)	Channel	CH 155 : 5775 MHz
Frequency Range	1 GHz ~ 40 GHz	Detector Function & Bandwidth	PK: RB=1 MHz, VB=3 MHz, DET=Peak AV: RB=1 MHz, VB=10 Hz, DET=Peak
Input Power	120 Vac, 60 Hz	Environmental Conditions	23 °C, 66 % RH
Tested By	TitanHSU		

Antenna Polarity & Test Distance : Horizontal at 3 m

No	Frequency (MHz)	Emission Level (dBuV/m)	Limit (dBuV/m)	Margin (dB)	Antenna Height (m)	Table Angle (Degree)	Raw Value (dBuV)	Correction Factor (dB/m)
1	#5620.00	60.9 PK	68.2	-7.3	2.18 H	86	47.7	13.2
2	*5775.00	112.8 PK			2.18 H	86	68.2	44.6
3	*5775.00	100.7 AV			2.18 H	86	56.1	44.6
4	#5953.20	61.6 PK	68.2	-6.6	2.18 H	86	47.6	14.0
5	11550.00	62.7 PK	74.0	-11.3	1.72 H	192	39.6	23.1
6	11550.00	48.9 AV	54.0	-5.1	1.72 H	192	25.8	23.1

Antenna Polarity & Test Distance : Vertical at 3 m

No	Frequency (MHz)	Emission Level (dBuV/m)	Limit (dBuV/m)	Margin (dB)	Antenna Height (m)	Table Angle (Degree)	Raw Value (dBuV)	Correction Factor (dB/m)
1	#5646.80	67.7 PK	68.2	-0.5	1.56 V	328	54.3	13.4
2	*5775.00	120.3 PK			1.56 V	328	75.7	44.6
3	*5775.00	107.7 AV			1.56 V	328	63.1	44.6
4	#5926.40	62.4 PK	68.2	-5.8	1.56 V	328	48.5	13.9
5	11550.00	63.1 PK	74.0	-10.9	2.36 V	195	40.0	23.1
6	11550.00	49.3 AV	54.0	-4.7	2.36 V	195	26.2	23.1

Remarks:

1. Emission Level(dBuV/m) = Raw Value(dBuV) + Correction Factor(dB/m)
2. Correction Factor(dB/m) = Antenna Factor(dB/m) + Cable Factor(dB) – Pre-Amplifier Factor(dB)
3. Margin value = Emission Level – Limit value
4. The other emission levels were very low against the limit.
5. " * " : Fundamental frequency, the limit was restricted at the RF Output Power.
6. " # " : The radiated frequency is out of the restricted band.

Plot of Band Edge

Frequency Range	4.5 GHz ~ 5.46 GHz	Detector Function & Bandwidth	PK: RB=1 MHz, VB=3 MHz, DET=Peak AV: RB=1 MHz, VB=10 Hz, DET=Peak
-----------------	--------------------	-------------------------------	--

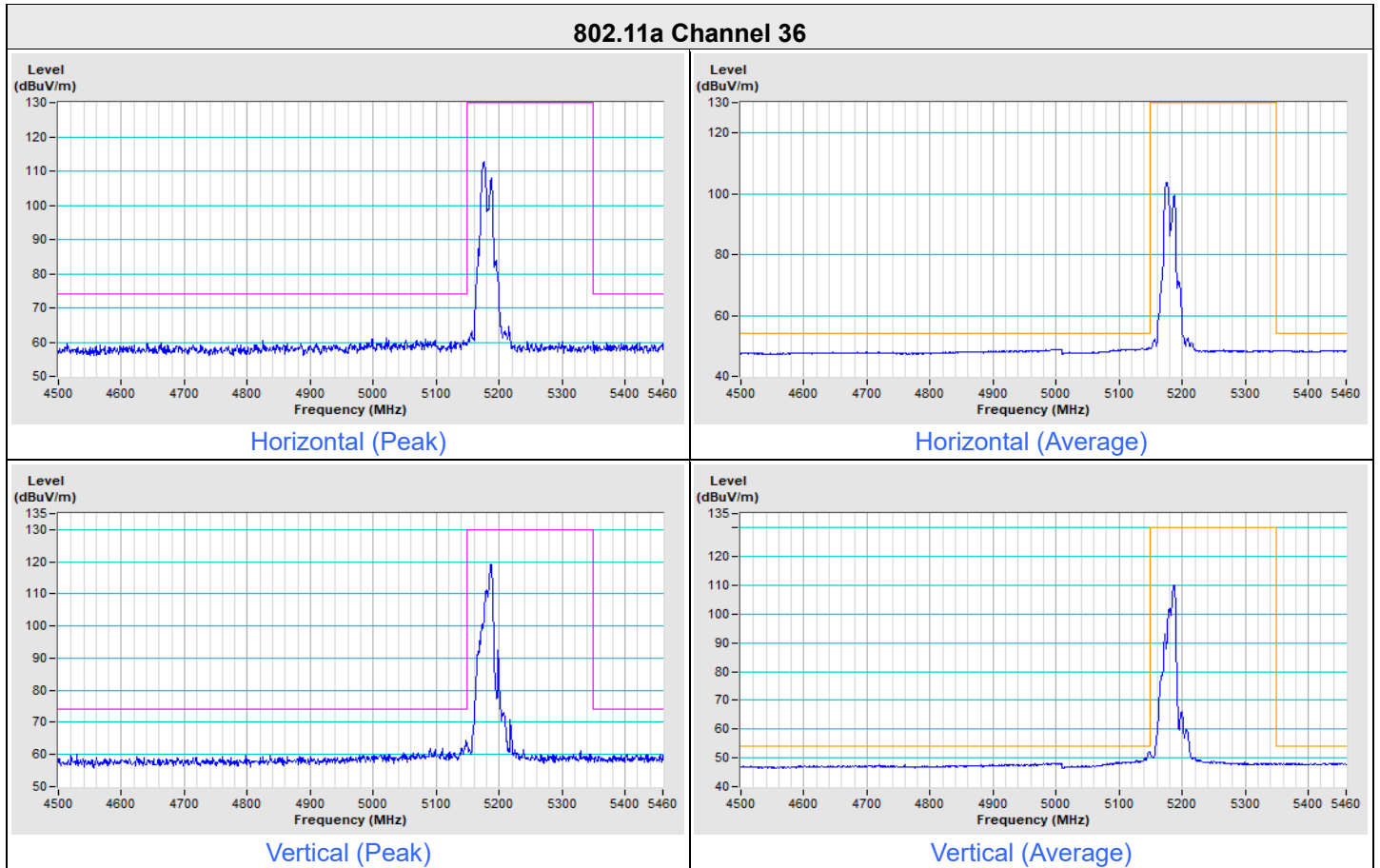

802.11a Channel 48

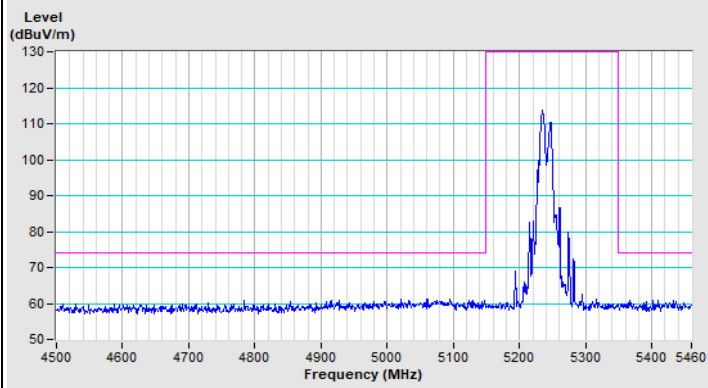

Horizontal (Peak)

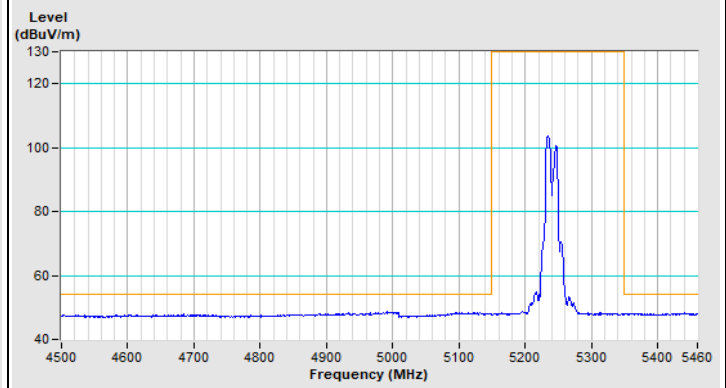

Horizontal (Average)

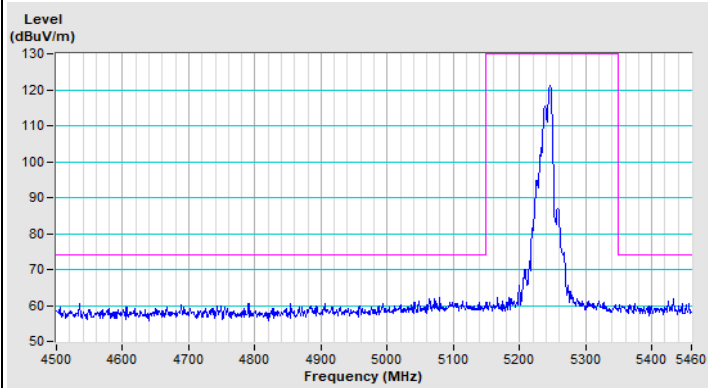

Vertical (Peak)

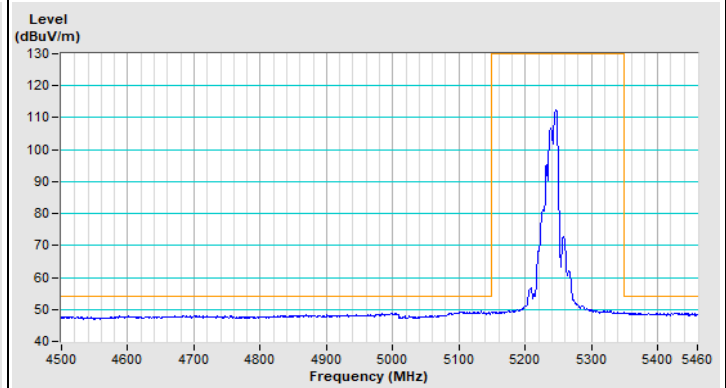

Vertical (Average)

Frequency Range	4.5 GHz ~ 5.46 GHz	Detector Function & Bandwidth	PK: RB=1 MHz, VB=3 MHz, DET=Peak AV: RB=1 MHz, VB=10 Hz, DET=Peak
-----------------	--------------------	-------------------------------	--

802.11a Channel 52

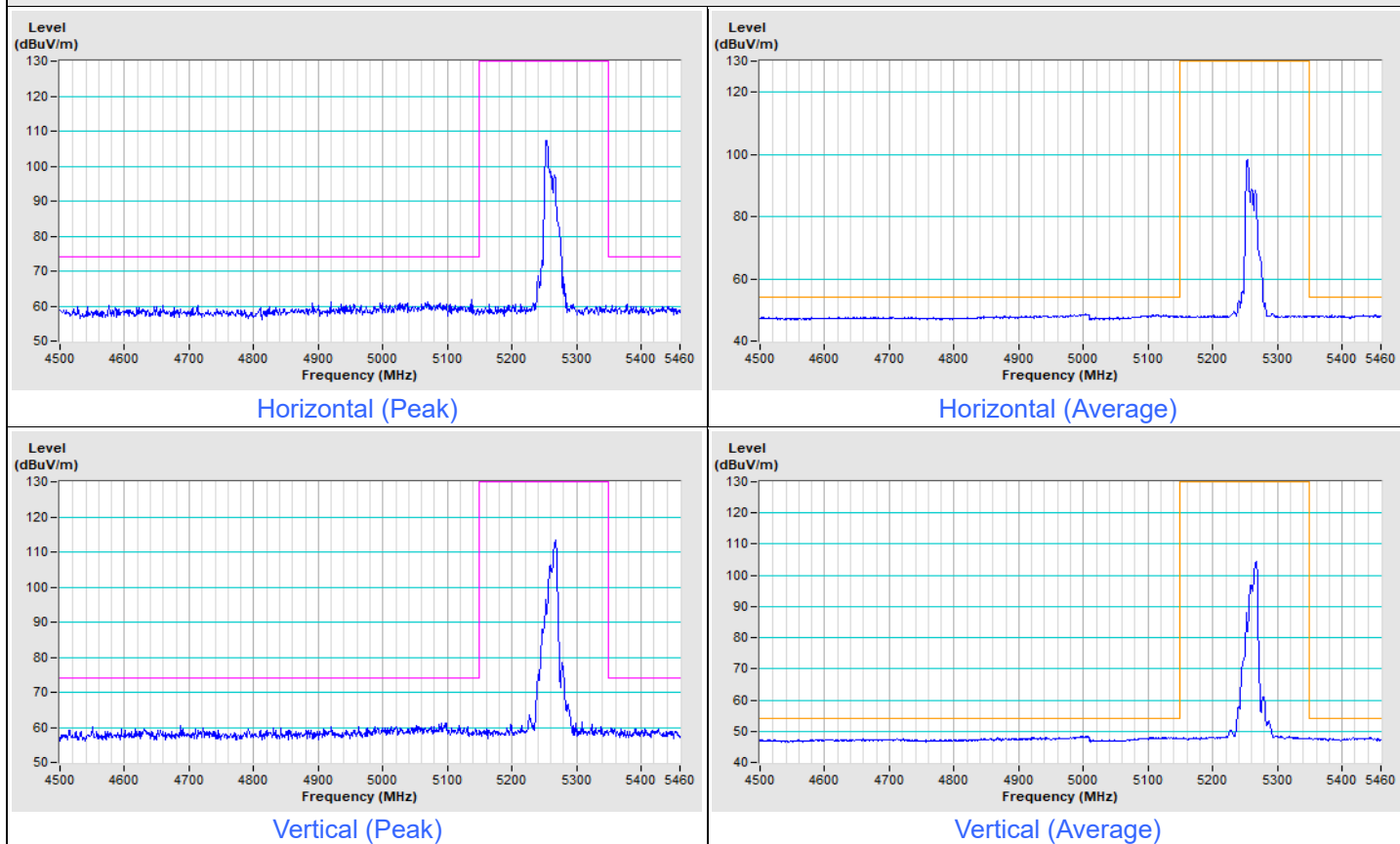

802.11a Channel 64

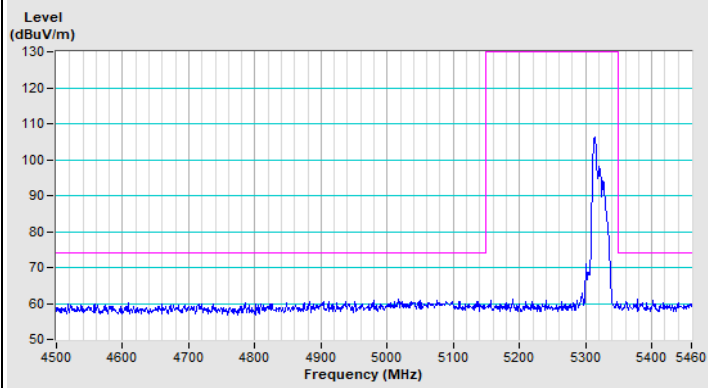

Horizontal (Peak)

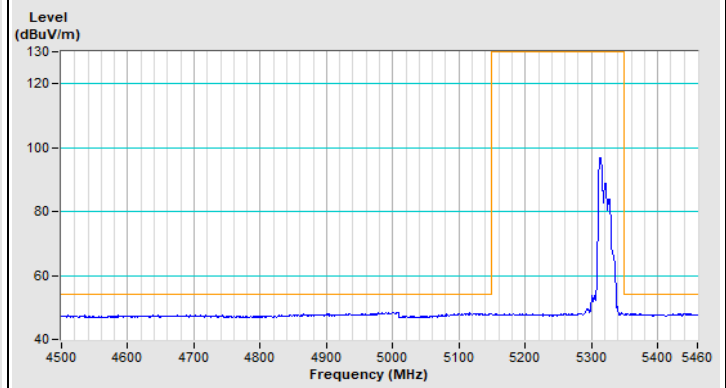

Horizontal (Average)

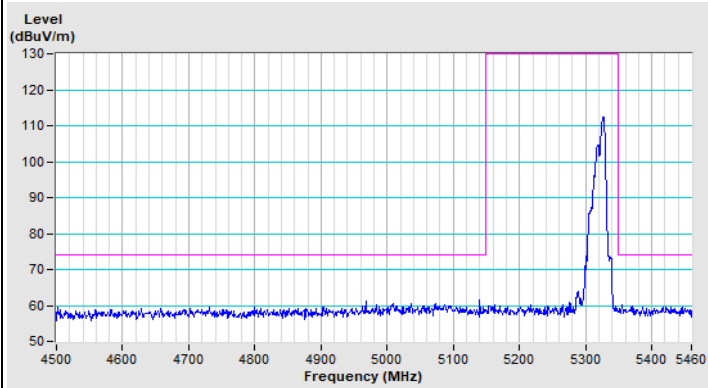

Vertical (Peak)

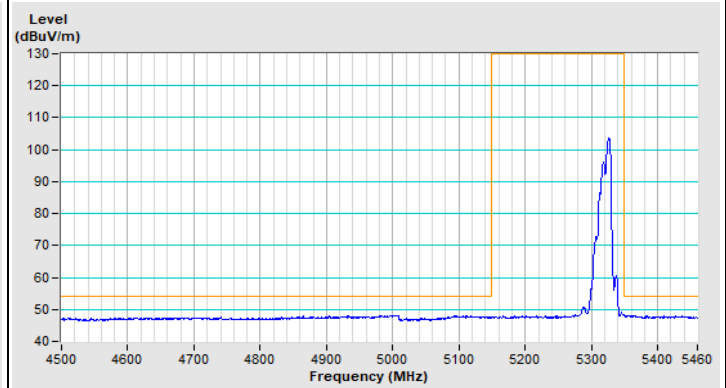

Vertical (Average)

Frequency Range	5.35 GHz ~ 5.85 GHz	Detector Function & Bandwidth	PK: RB=1 MHz, VB=3 MHz, DET=Peak AV: RB=1 MHz, VB=10 Hz, DET=Peak
-----------------	---------------------	-------------------------------	--

802.11a Channel 100

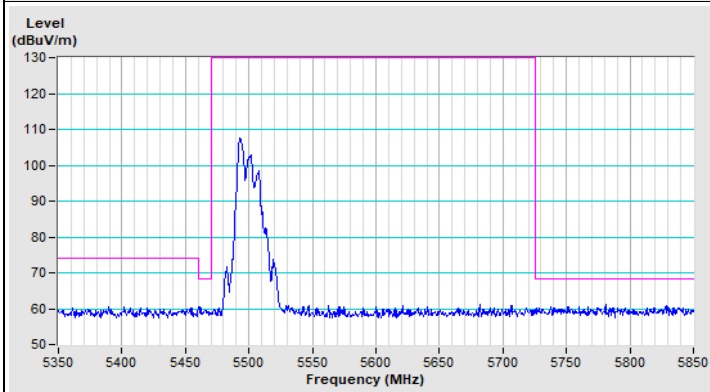

Horizontal (Peak)

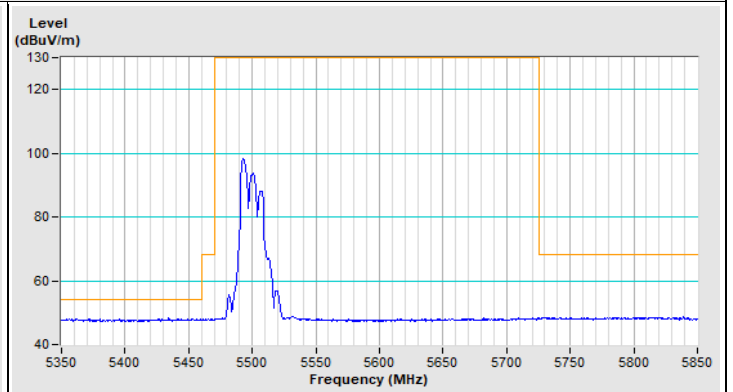

Horizontal (Average)

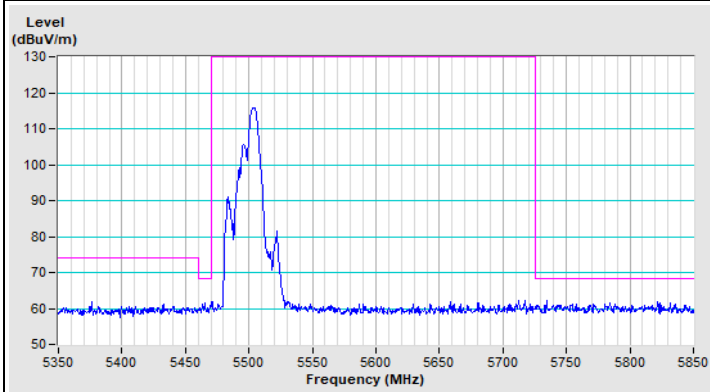

Vertical (Peak)

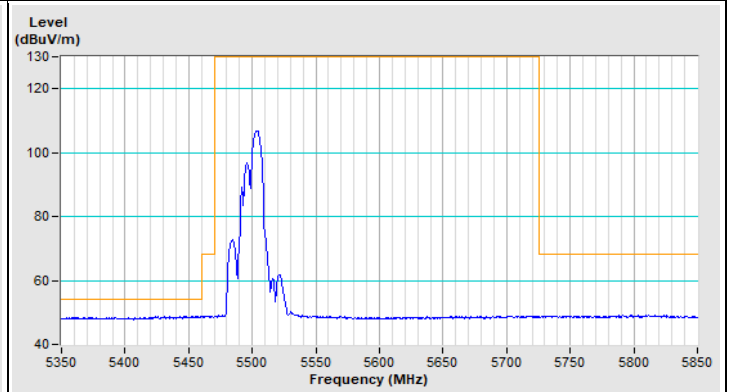

Vertical (Average)

802.11a Channel 140

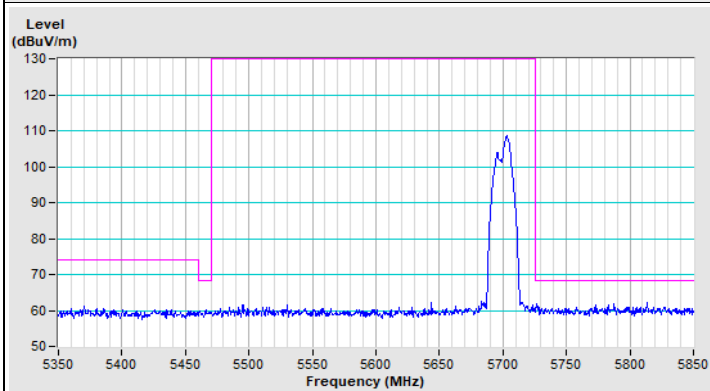

Horizontal (Peak)

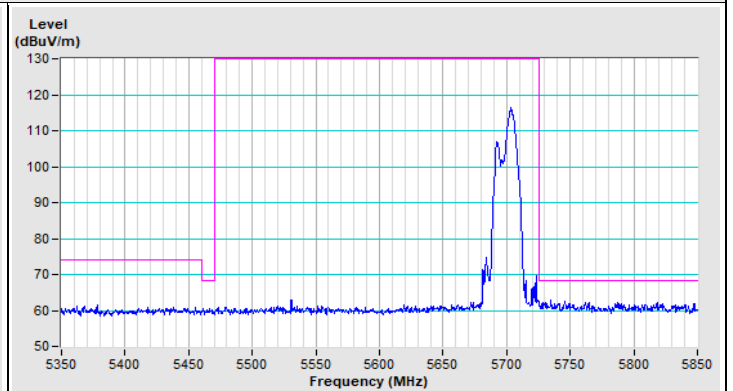

Vertical (Peak)

Frequency Range	5.35 GHz ~ 5.95 GHz	Detector Function & Bandwidth	PK: RB=1 MHz, VB=3 MHz, DET=Peak
-----------------	---------------------	-------------------------------	----------------------------------

802.11a Channel 144

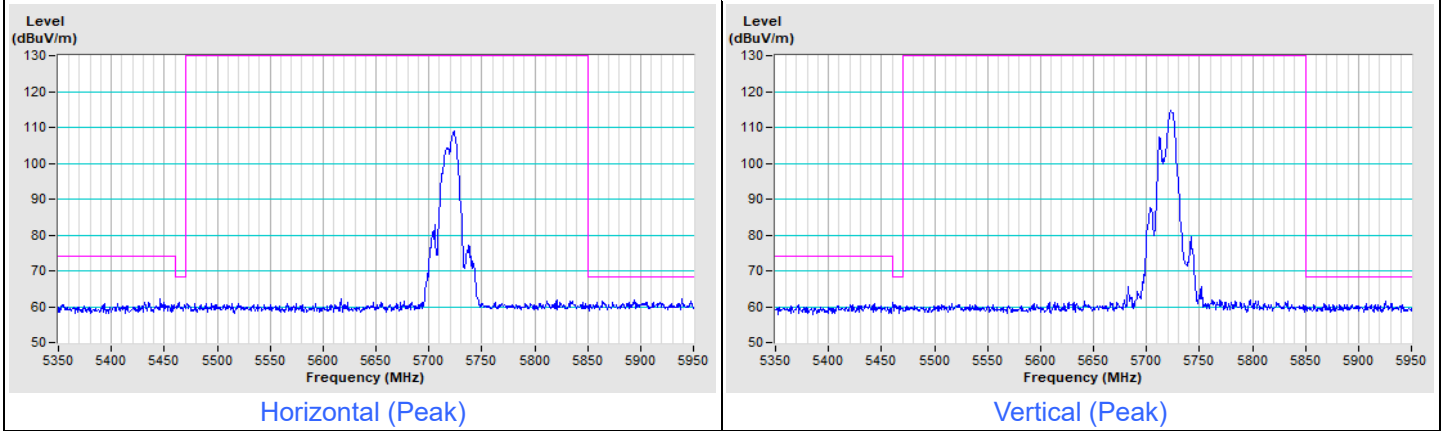

Frequency Range	5.6 GHz ~ 6 GHz	Detector Function & Bandwidth	PK: RB=1 MHz, VB=3 MHz, DET=Peak
-----------------	-----------------	-------------------------------	----------------------------------

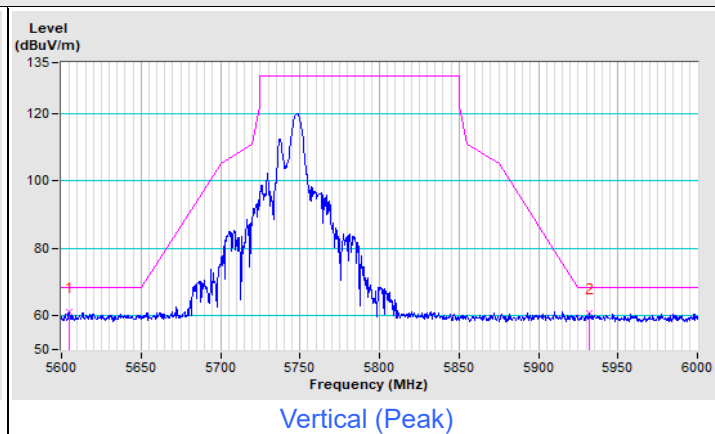
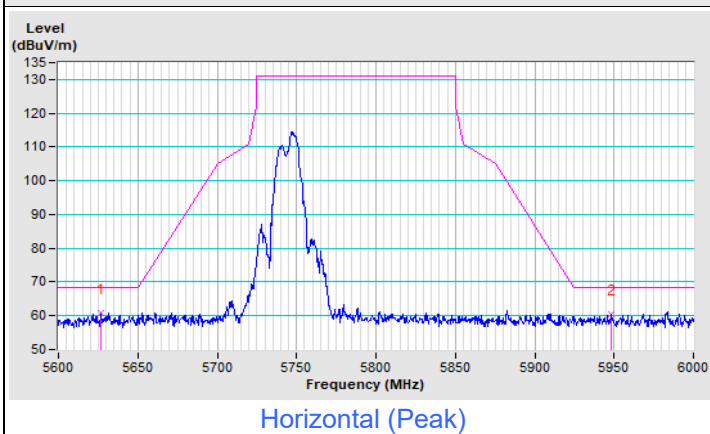
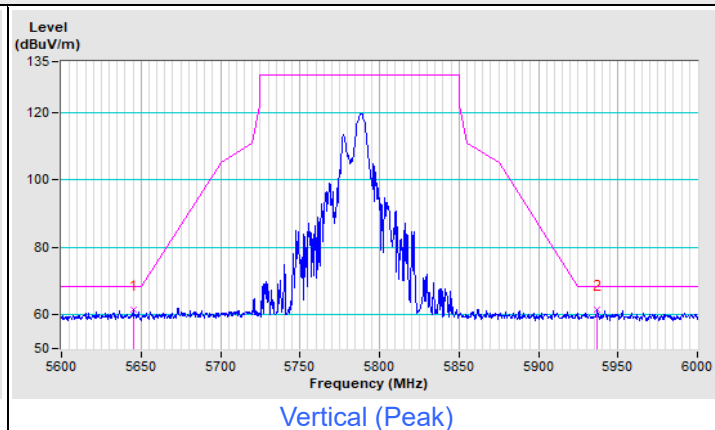
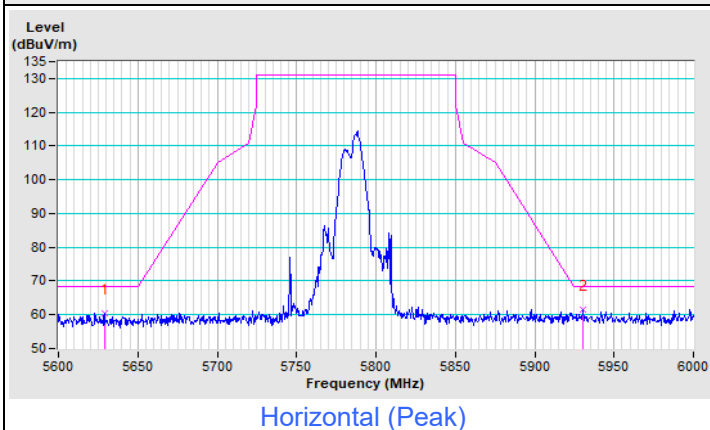
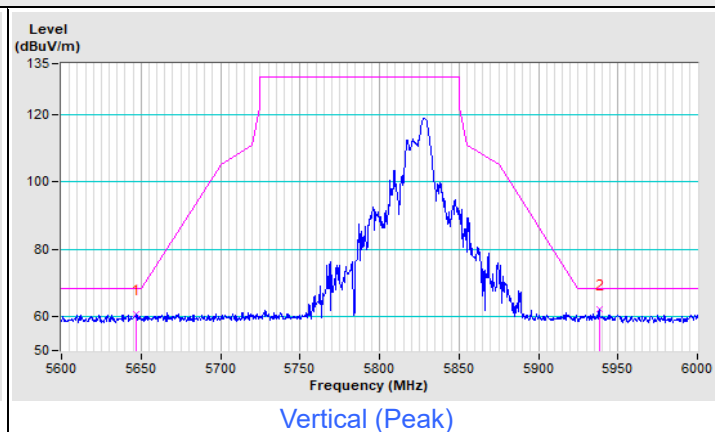
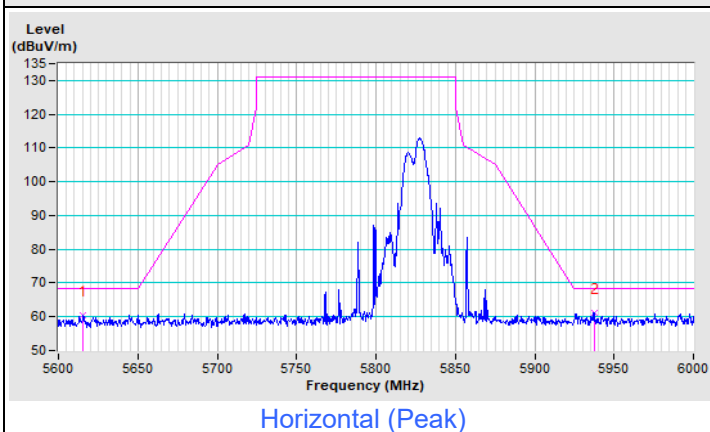
802.11a Channel 149**802.11a Channel 157****802.11a Channel 165**

Frequency Range	4.5 GHz ~ 5.46 GHz	Detector Function & Bandwidth	PK: RB=1 MHz, VB=3 MHz, DET=Peak AV: RB=1 MHz, VB=10 Hz, DET=Peak
-----------------	--------------------	-------------------------------	--

802.11be (EHT20) Channel 36

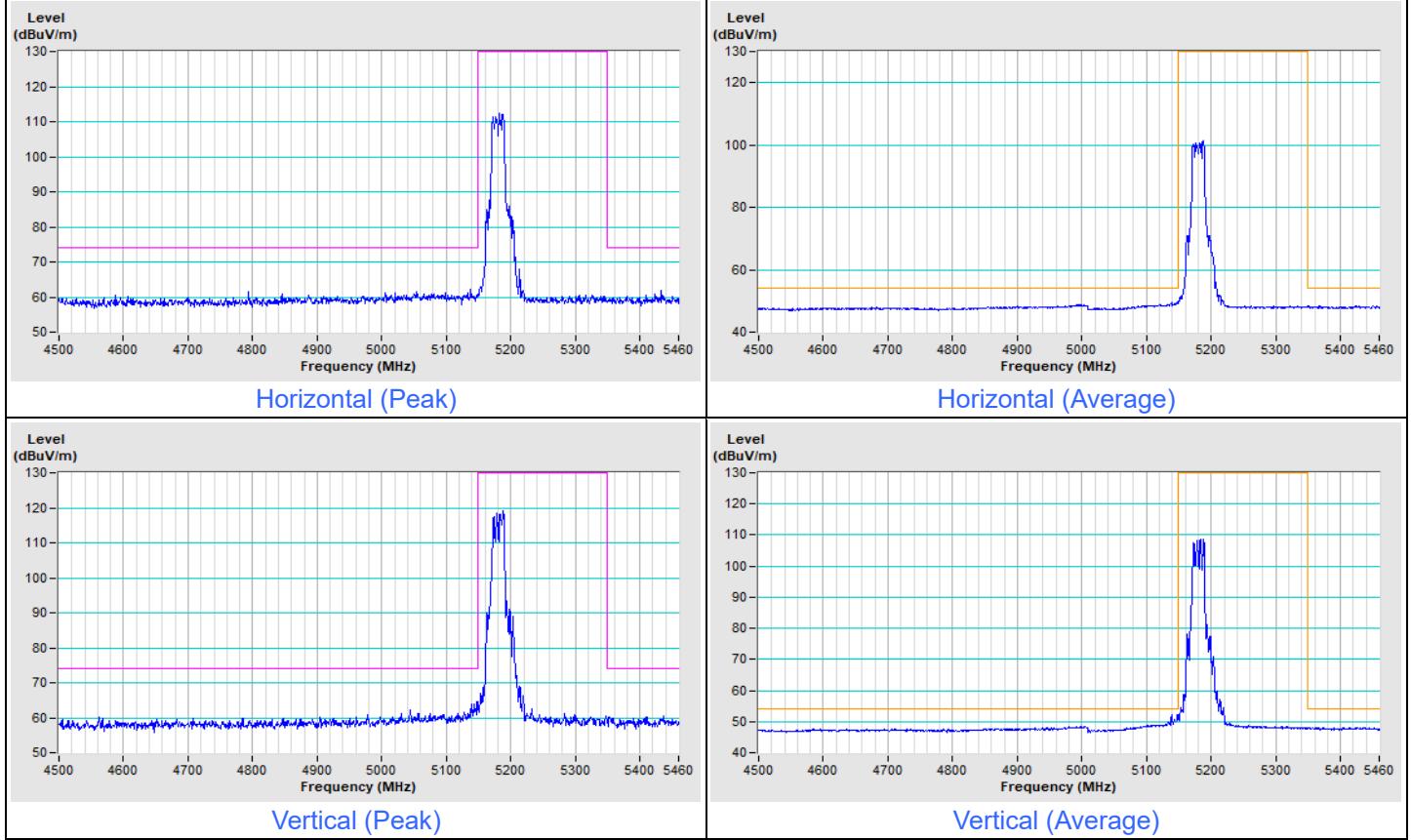

802.11be (EHT20) Channel 48

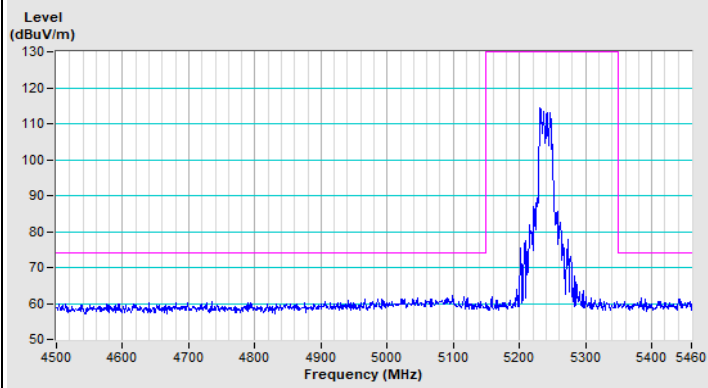

Horizontal (Peak)

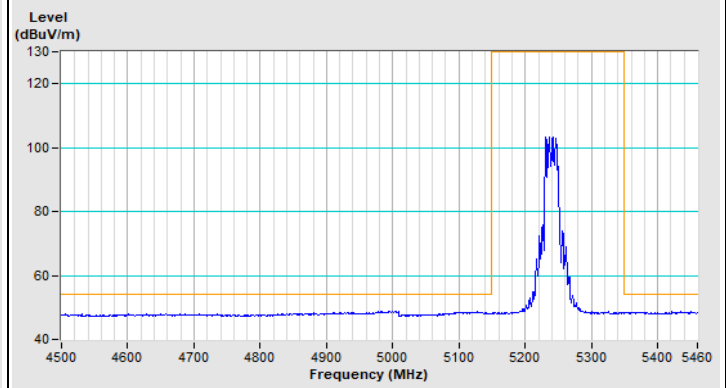

Horizontal (Average)

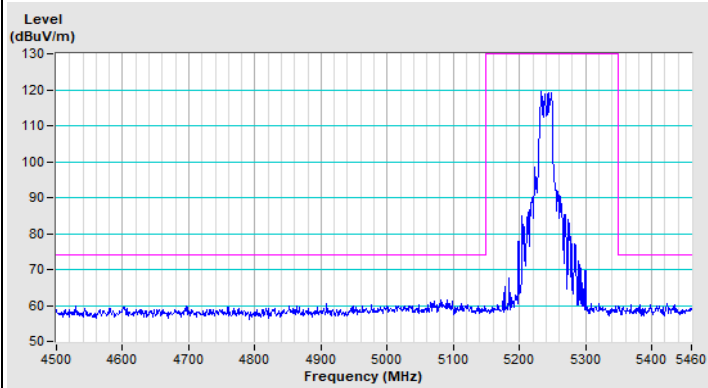

Vertical (Peak)

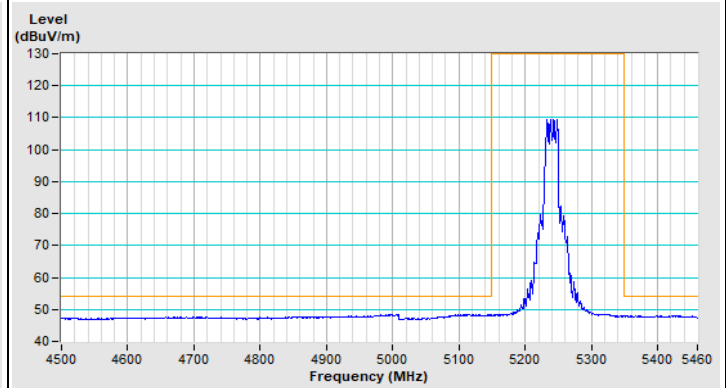

Vertical (Average)

Frequency Range	4.5 GHz ~ 5.46 GHz	Detector Function & Bandwidth	PK: RB=1 MHz, VB=3 MHz, DET=Peak AV: RB=1 MHz, VB=10 Hz, DET=Peak
-----------------	--------------------	-------------------------------	--

802.11be (EHT20) Channel 52

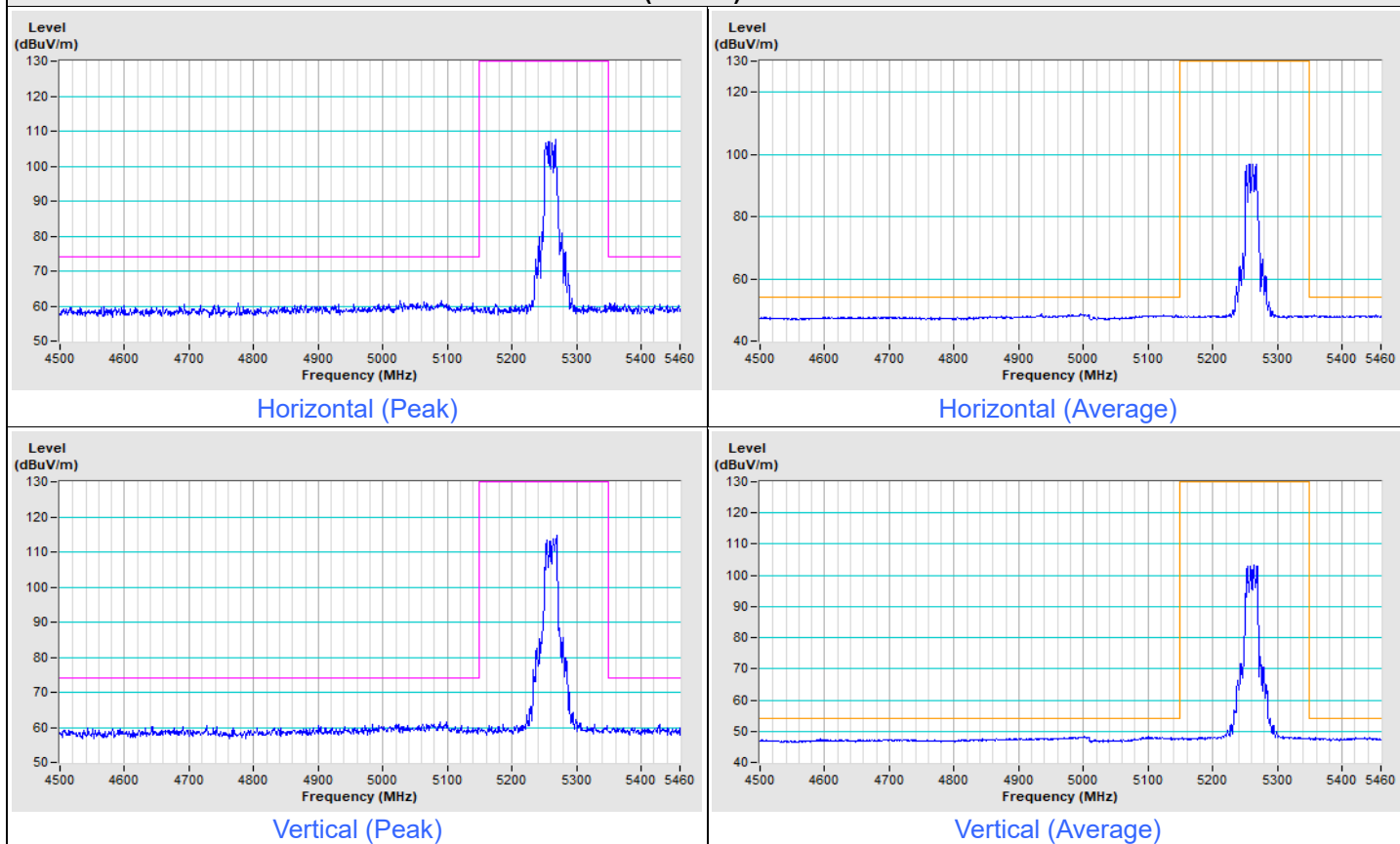

802.11be (EHT20) Channel 64

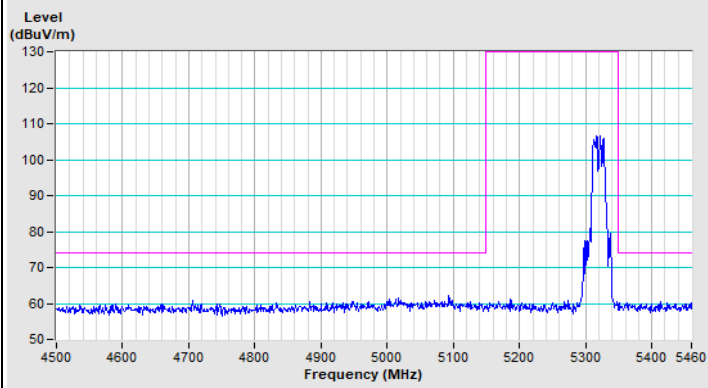

Horizontal (Peak)

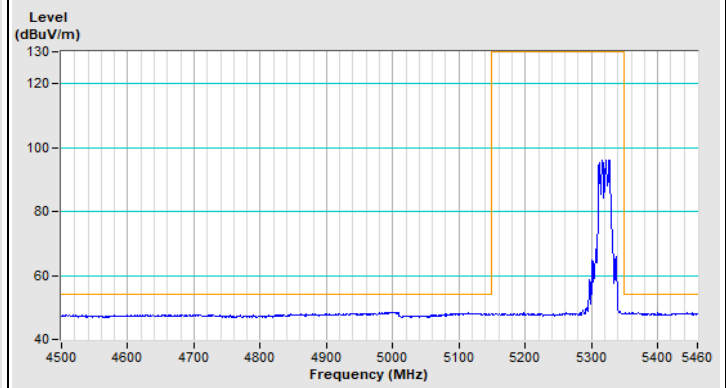

Horizontal (Average)

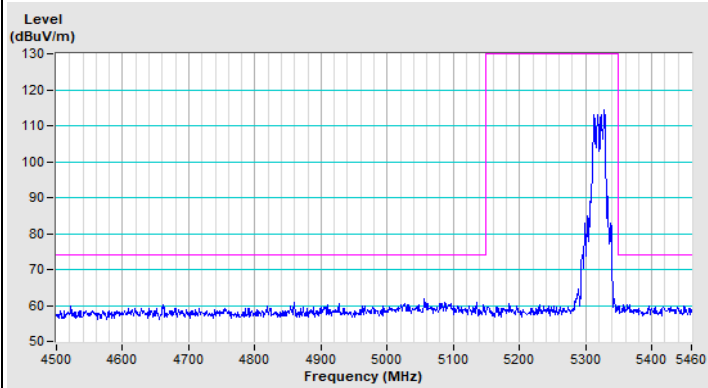

Vertical (Peak)

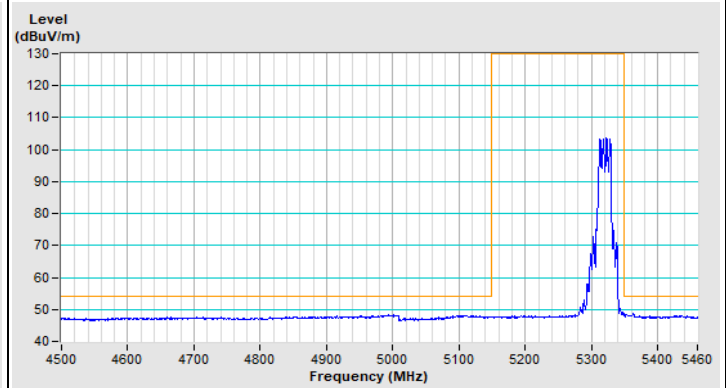

Vertical (Average)

Frequency Range	5.35 GHz ~ 5.85 GHz	Detector Function & Bandwidth	PK: RB=1 MHz, VB=3 MHz, DET=Peak AV: RB=1 MHz, VB=10 Hz, DET=Peak
-----------------	---------------------	-------------------------------	--

802.11be (EHT20) Channel 100

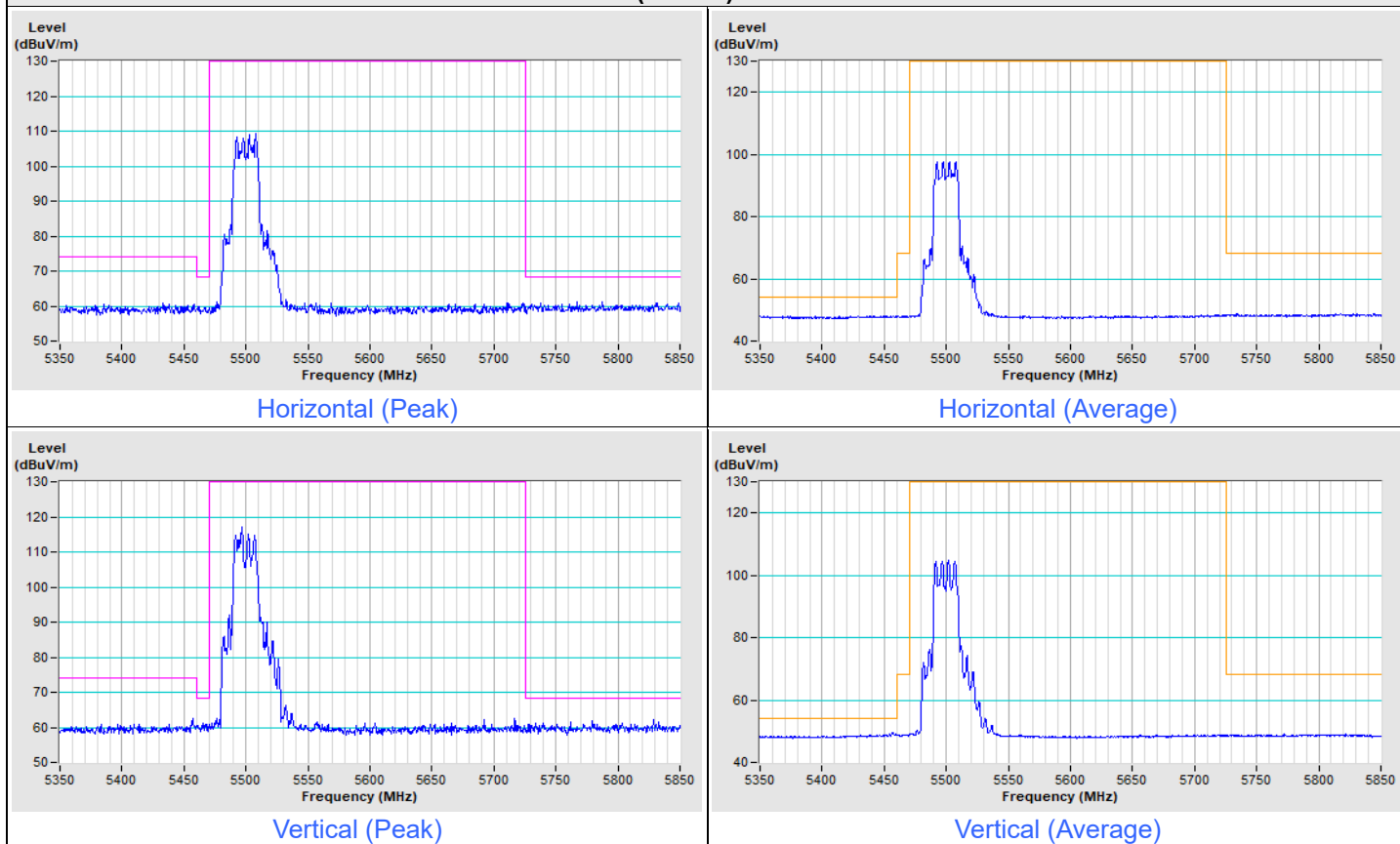

802.11be (EHT20) Channel 140

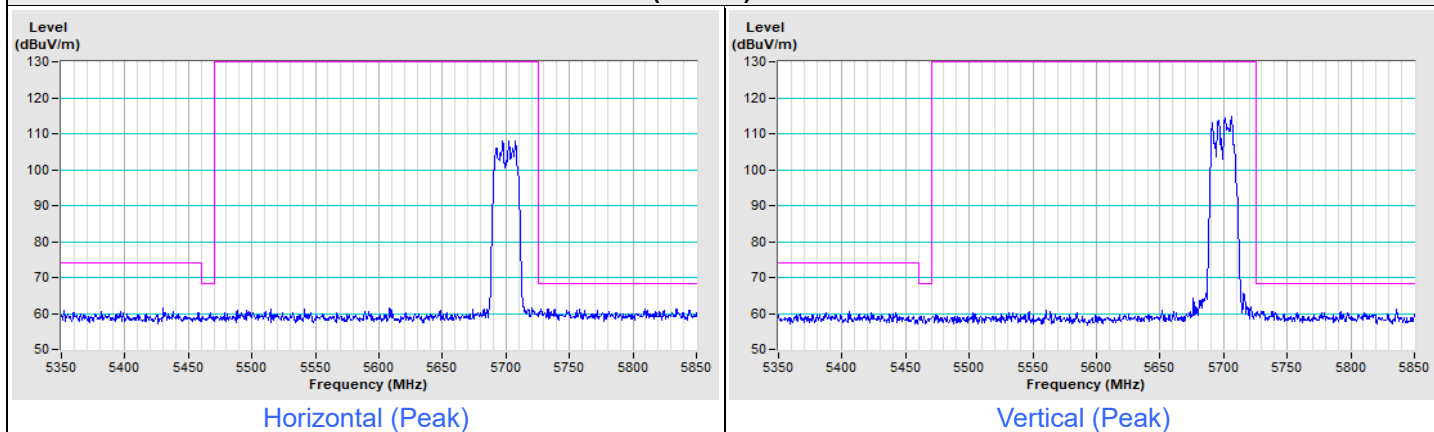

Frequency Range	5.35 GHz ~ 5.95 GHz	Detector Function & Bandwidth	PK: RB=1 MHz, VB=3 MHz, DET=Peak
-----------------	---------------------	-------------------------------	----------------------------------

802.11be (EHT20) Channel 144

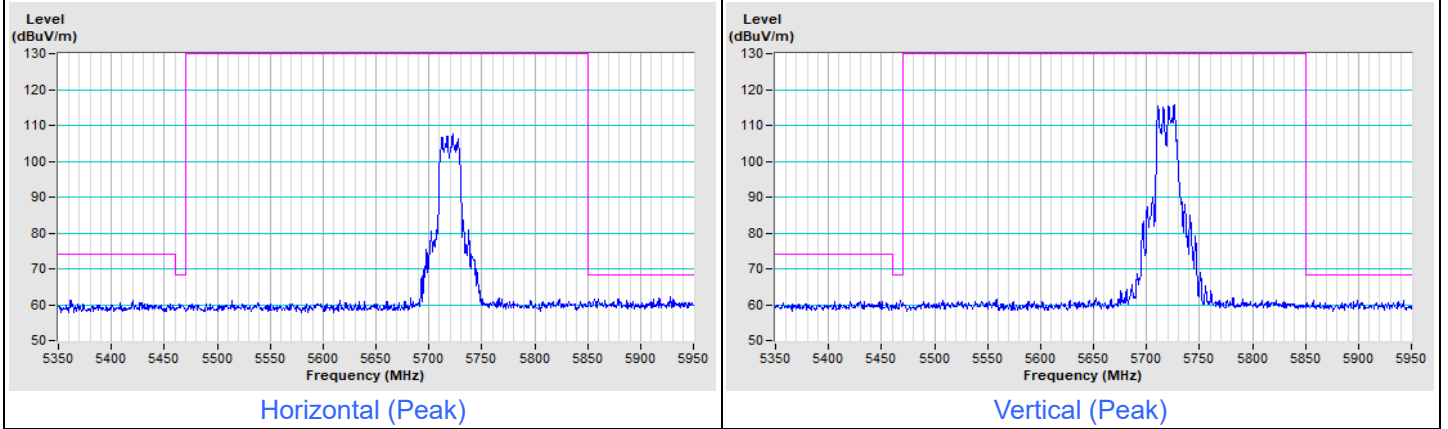

Frequency Range	5.6 GHz ~ 6 GHz	Detector Function & Bandwidth	PK: RB=1 MHz, VB=3 MHz, DET=Peak
-----------------	-----------------	-------------------------------	----------------------------------

802.11be (EHT20) Channel 149

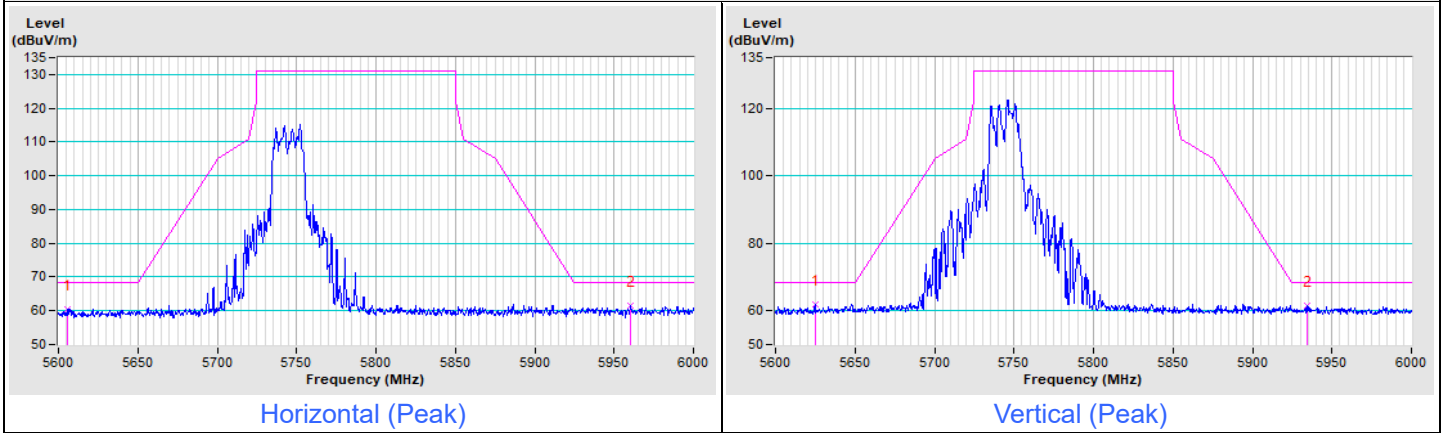

802.11be (EHT20) Channel 157

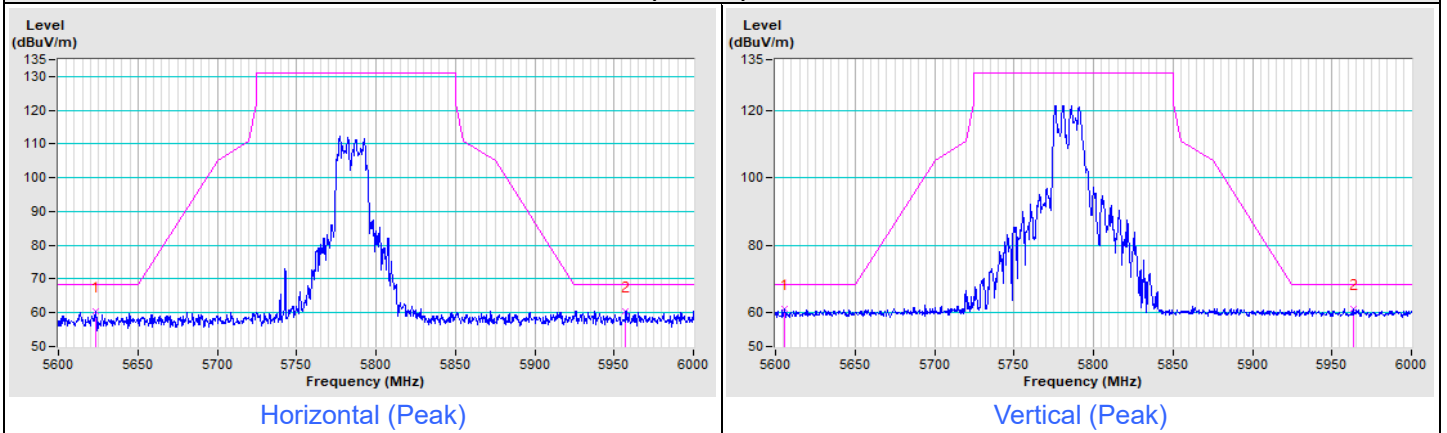

802.11be (EHT20) Channel 165

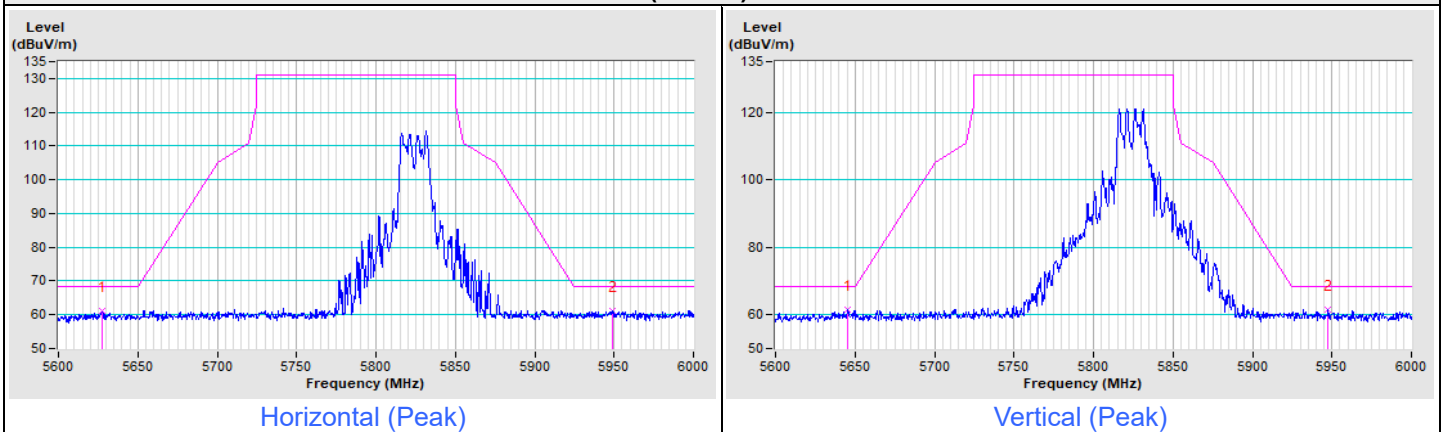



Frequency Range	4.5 GHz ~ 5.46 GHz	Detector Function & Bandwidth	PK: RB=1 MHz, VB=3 MHz, DET=Peak AV: RB=1 MHz, VB=10 Hz, DET=Peak
-----------------	--------------------	-------------------------------	--

802.11be (EHT40) Channel 38

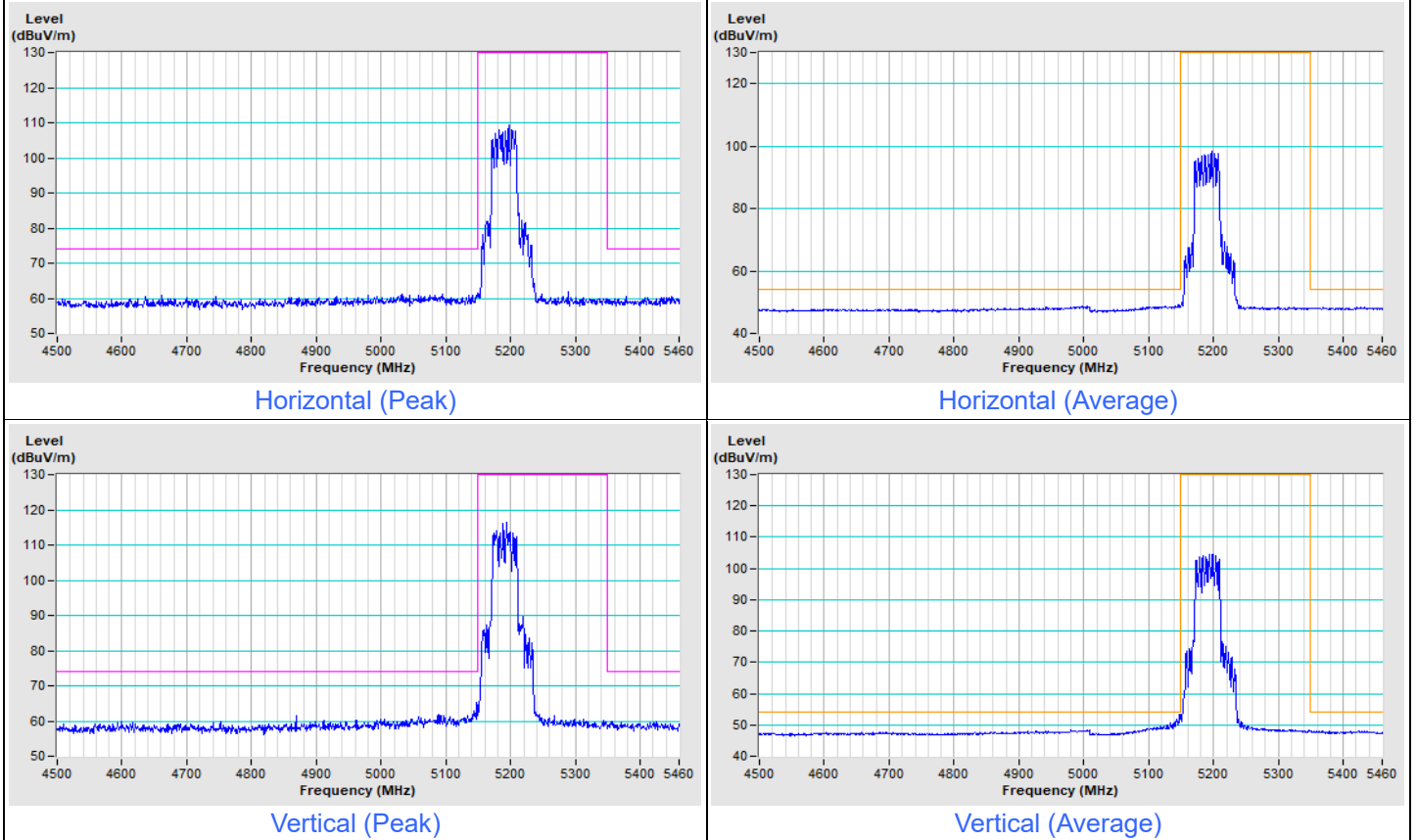

802.11be (EHT40) Channel 46

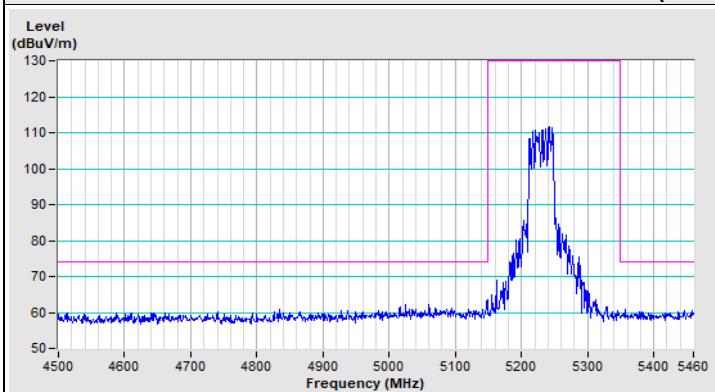

Horizontal (Peak)

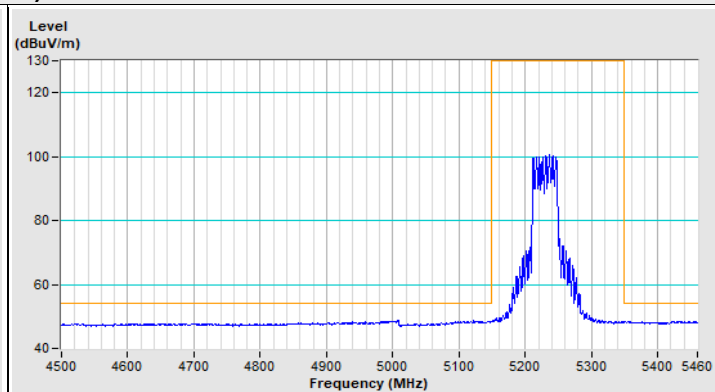

Horizontal (Average)

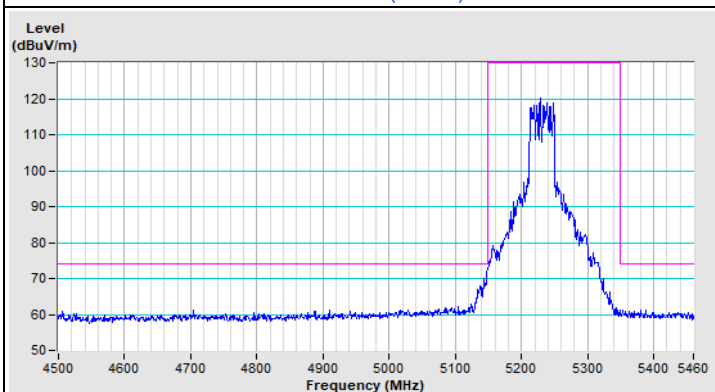

Vertical (Peak)

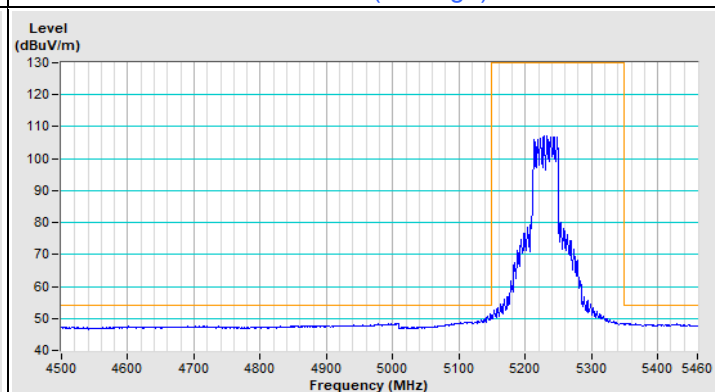

Vertical (Average)

Frequency Range	4.5 GHz ~ 5.46 GHz	Detector Function & Bandwidth	PK: RB=1 MHz, VB=3 MHz, DET=Peak AV: RB=1 MHz, VB=10 Hz, DET=Peak
-----------------	--------------------	-------------------------------	--

802.11be (EHT40) Channel 54

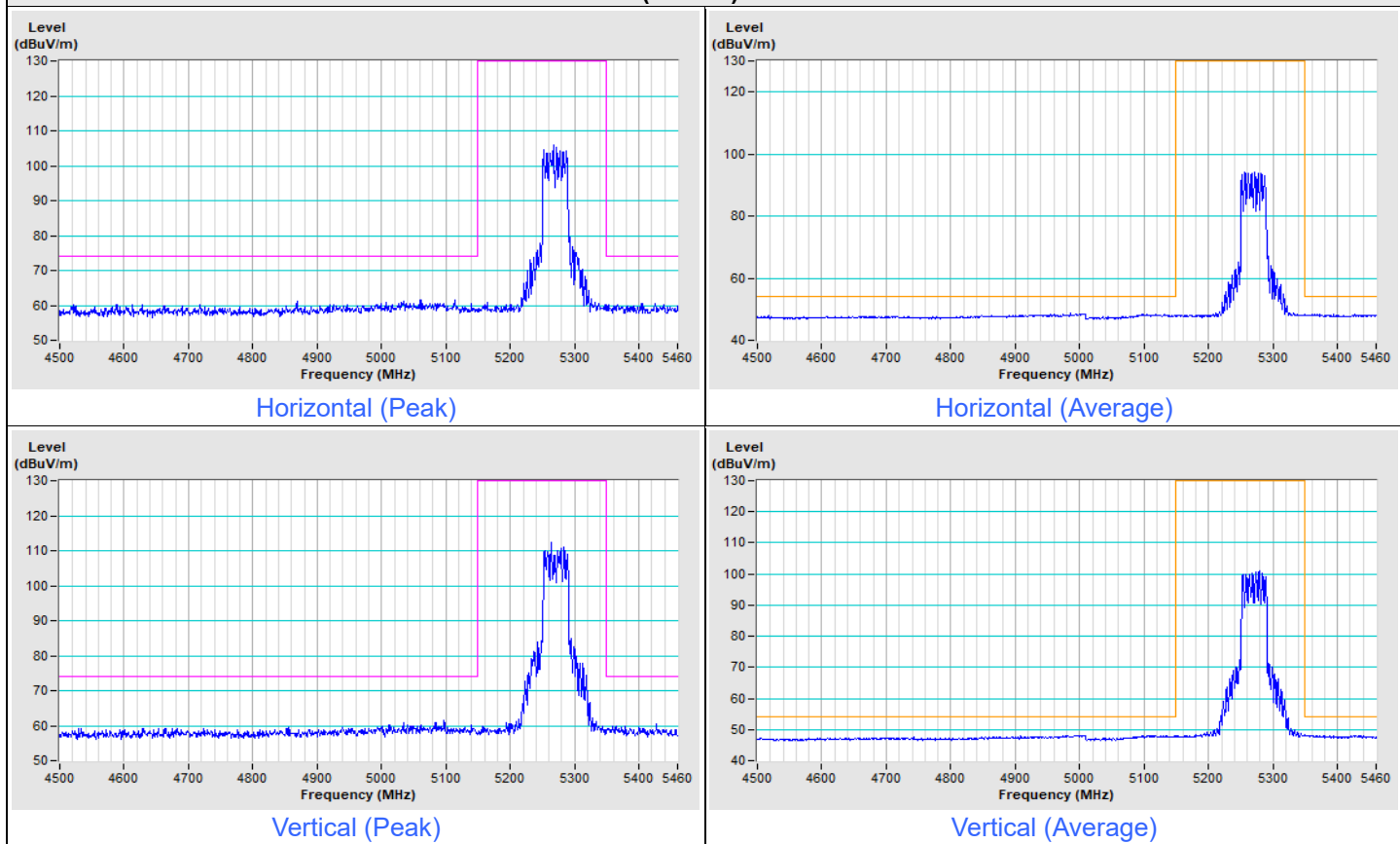

802.11be (EHT40) Channel 62

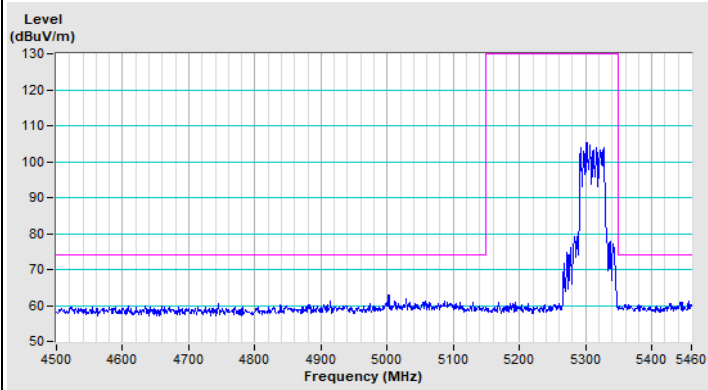

Horizontal (Peak)

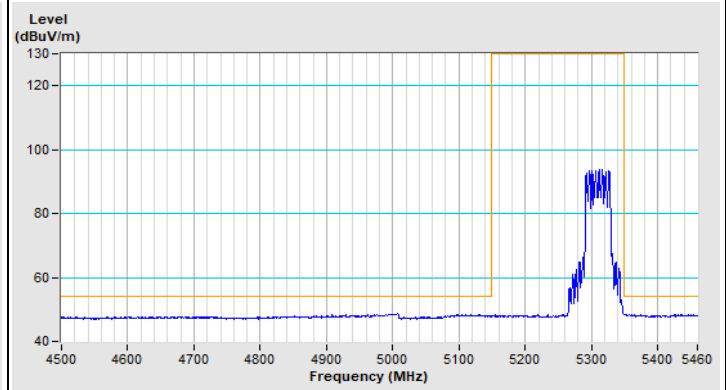

Horizontal (Average)

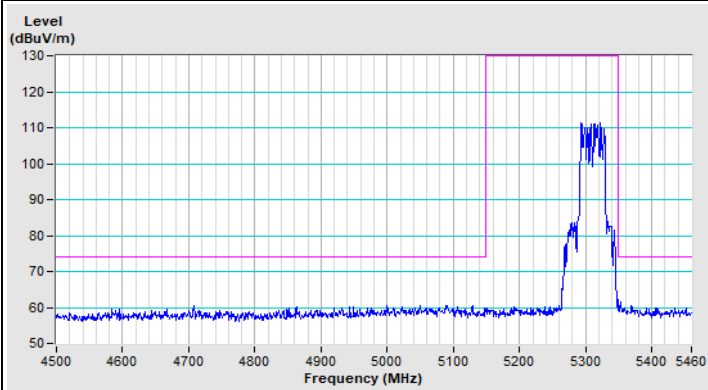

Vertical (Peak)

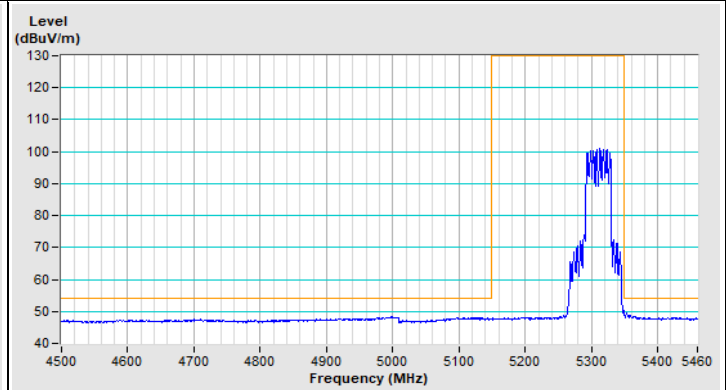

Vertical (Average)

Frequency Range	5.35 GHz ~ 5.85 GHz	Detector Function & Bandwidth	PK: RB=1 MHz, VB=3 MHz, DET=Peak AV: RB=1 MHz, VB=10 Hz, DET=Peak
-----------------	---------------------	-------------------------------	--

802.11be (EHT40) Channel 102

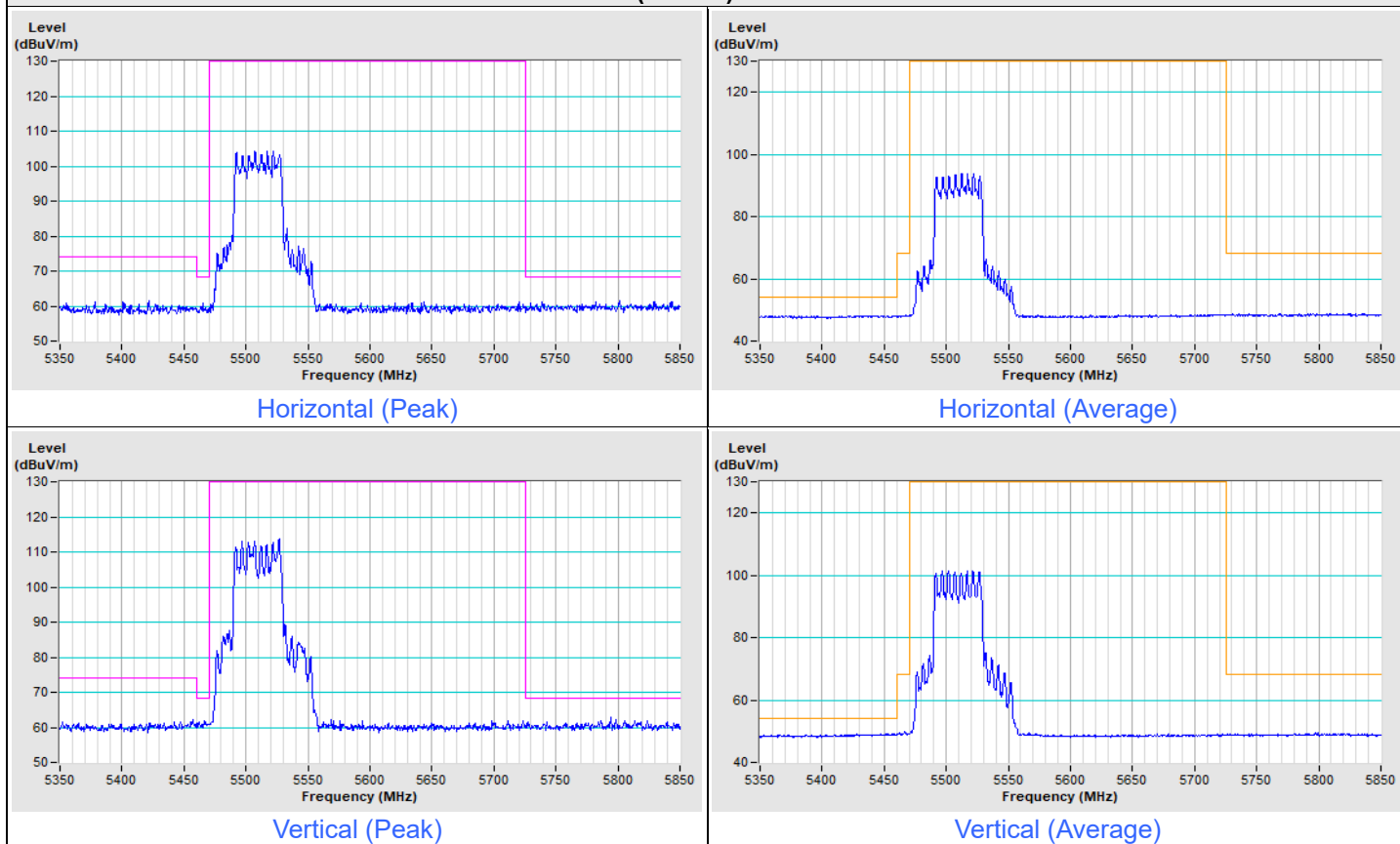

802.11be (EHT40) Channel 134

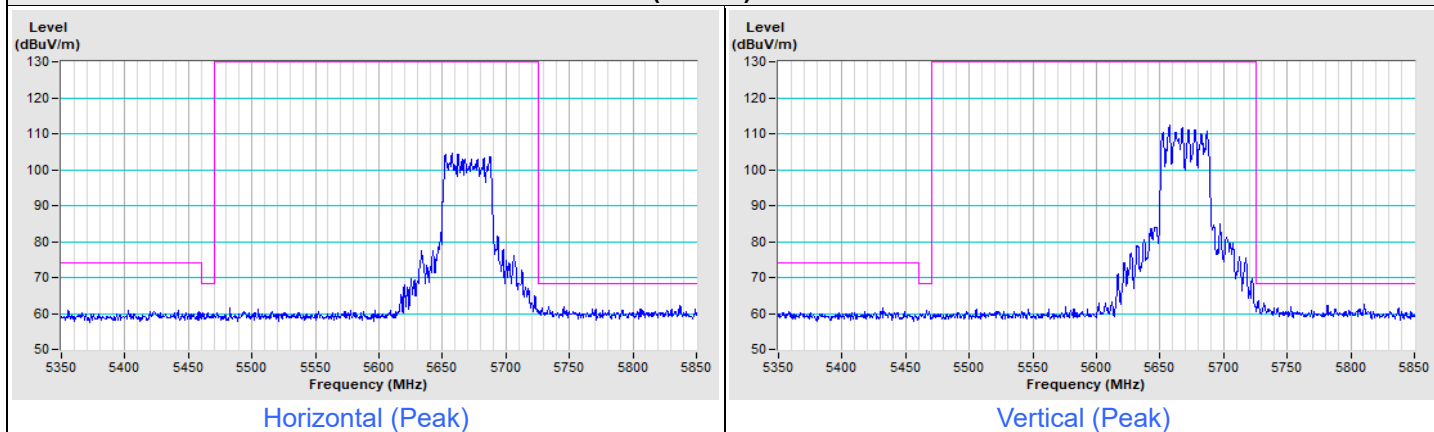

Frequency Range	5.35 GHz ~ 5.95 GHz	Detector Function & Bandwidth	PK: RB=1 MHz, VB=3 MHz, DET=Peak
-----------------	---------------------	-------------------------------	----------------------------------

802.11be (EHT40) Channel 142

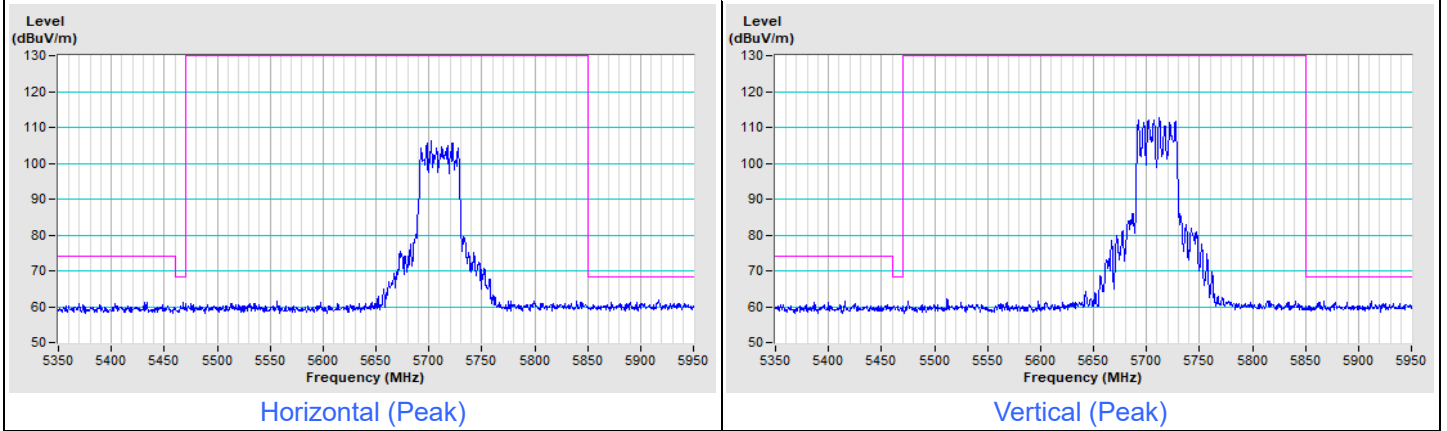

Frequency Range	5.6 GHz ~ 6 GHz	Detector Function & Bandwidth	PK: RB=1 MHz, VB=3 MHz, DET=Peak
-----------------	-----------------	-------------------------------	----------------------------------

802.11be (EHT40) Channel 151

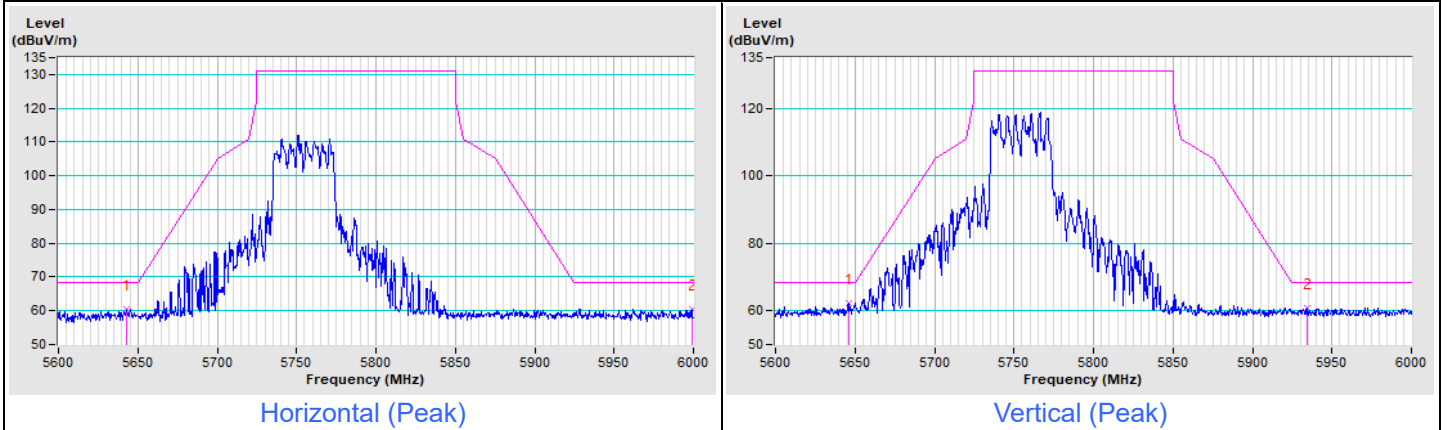

802.11be (EHT40) Channel 159

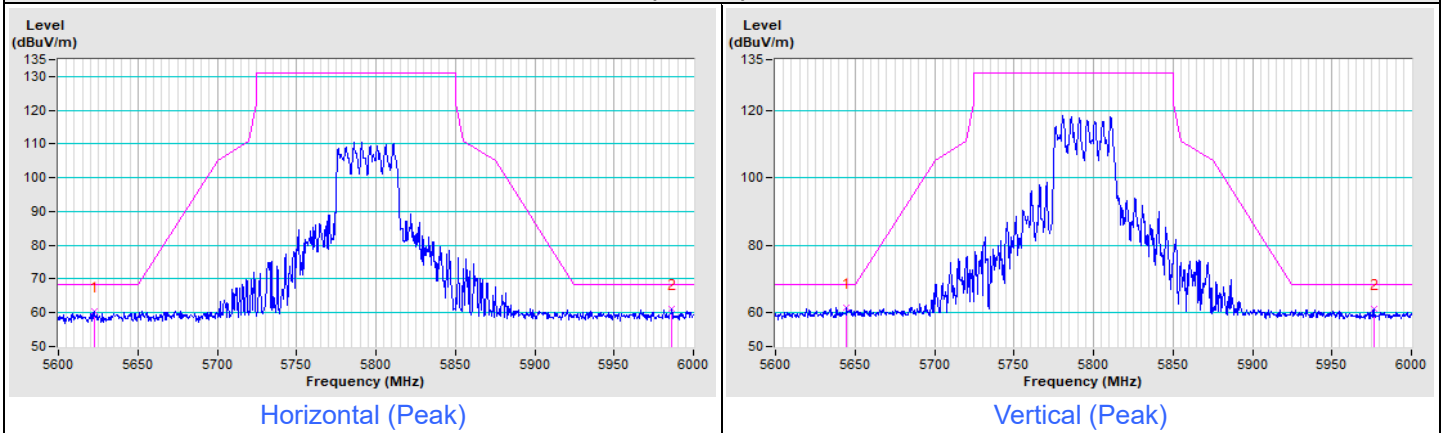

Frequency Range	4.5 GHz ~ 5.46 GHz	Detector Function & Bandwidth	PK: RB=1 MHz, VB=3 MHz, DET=Peak AV: RB=1 MHz, VB=10 Hz, DET=Peak
-----------------	--------------------	-------------------------------	--

802.11be (EHT80) Channel 42

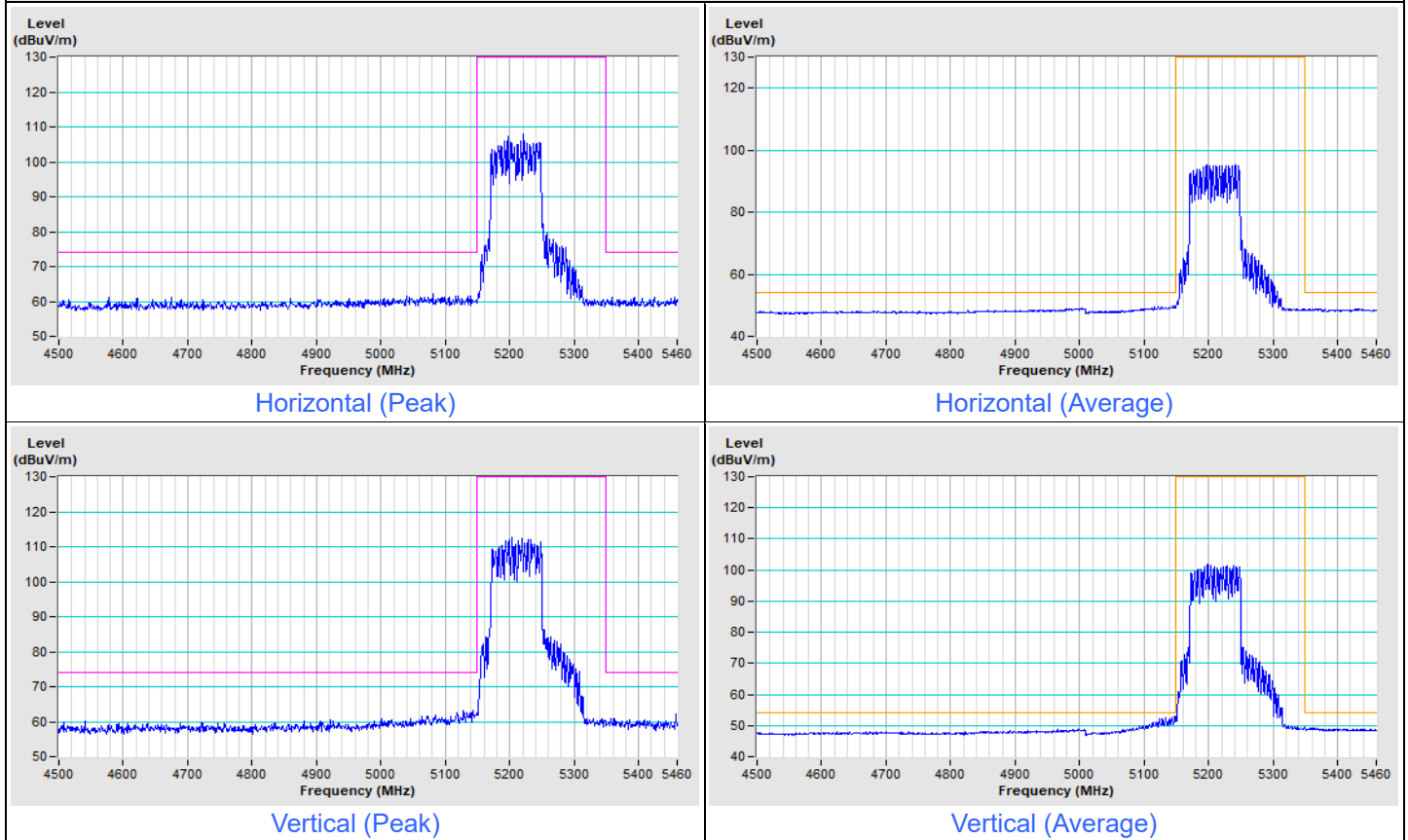

Frequency Range	4.5 GHz ~ 5.46 GHz	Detector Function & Bandwidth	PK: RB=1 MHz, VB=3 MHz, DET=Peak AV: RB=1 MHz, VB=10 Hz, DET=Peak
-----------------	--------------------	-------------------------------	--

802.11be (EHT80) Channel 58

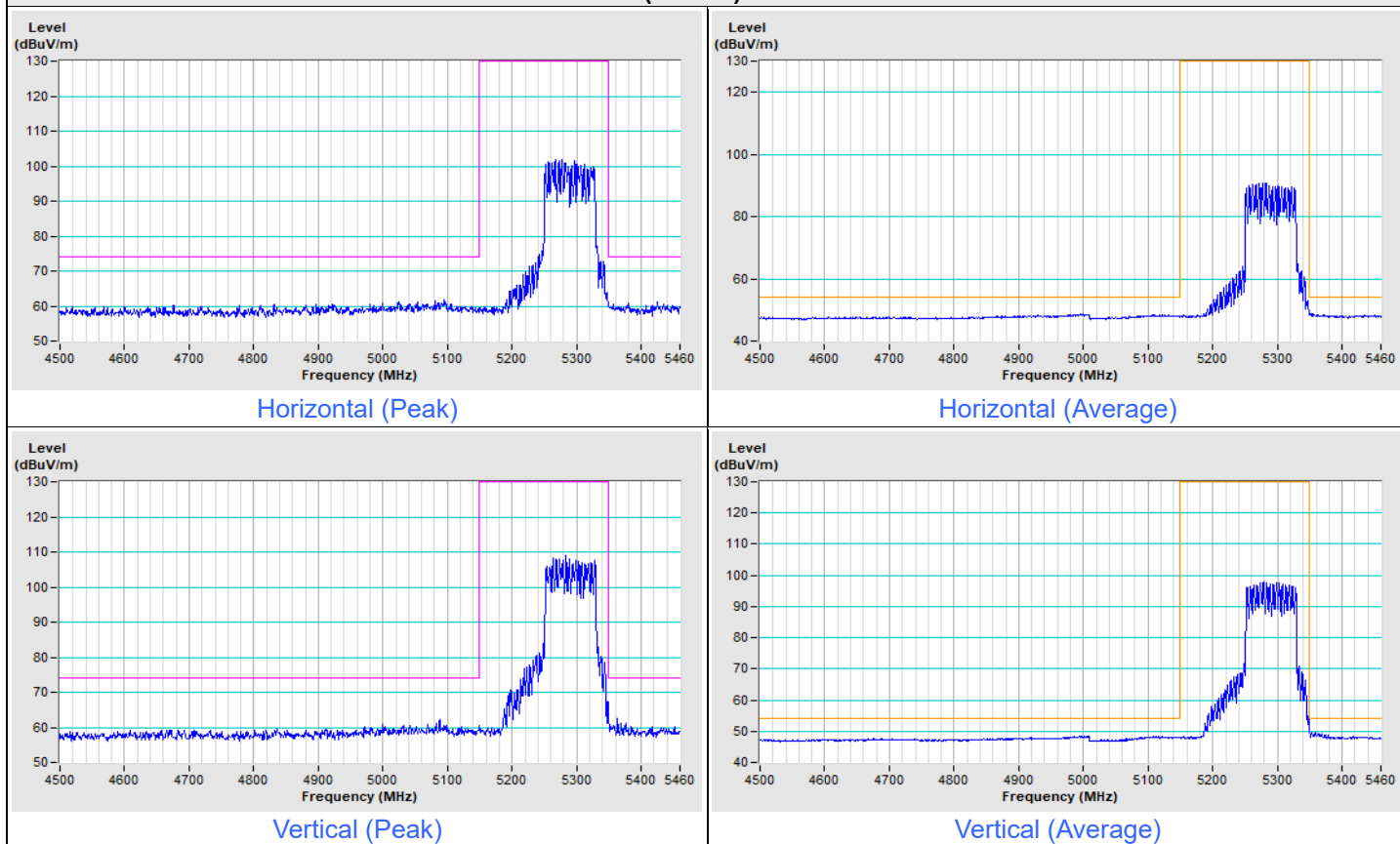

Frequency Range	5.35 GHz ~ 5.85 GHz	Detector Function & Bandwidth	PK: RB=1 MHz, VB=3 MHz, DET=Peak AV: RB=1 MHz, VB=10 Hz, DET=Peak
-----------------	---------------------	-------------------------------	--

802.11be (EHT80) Channel 106

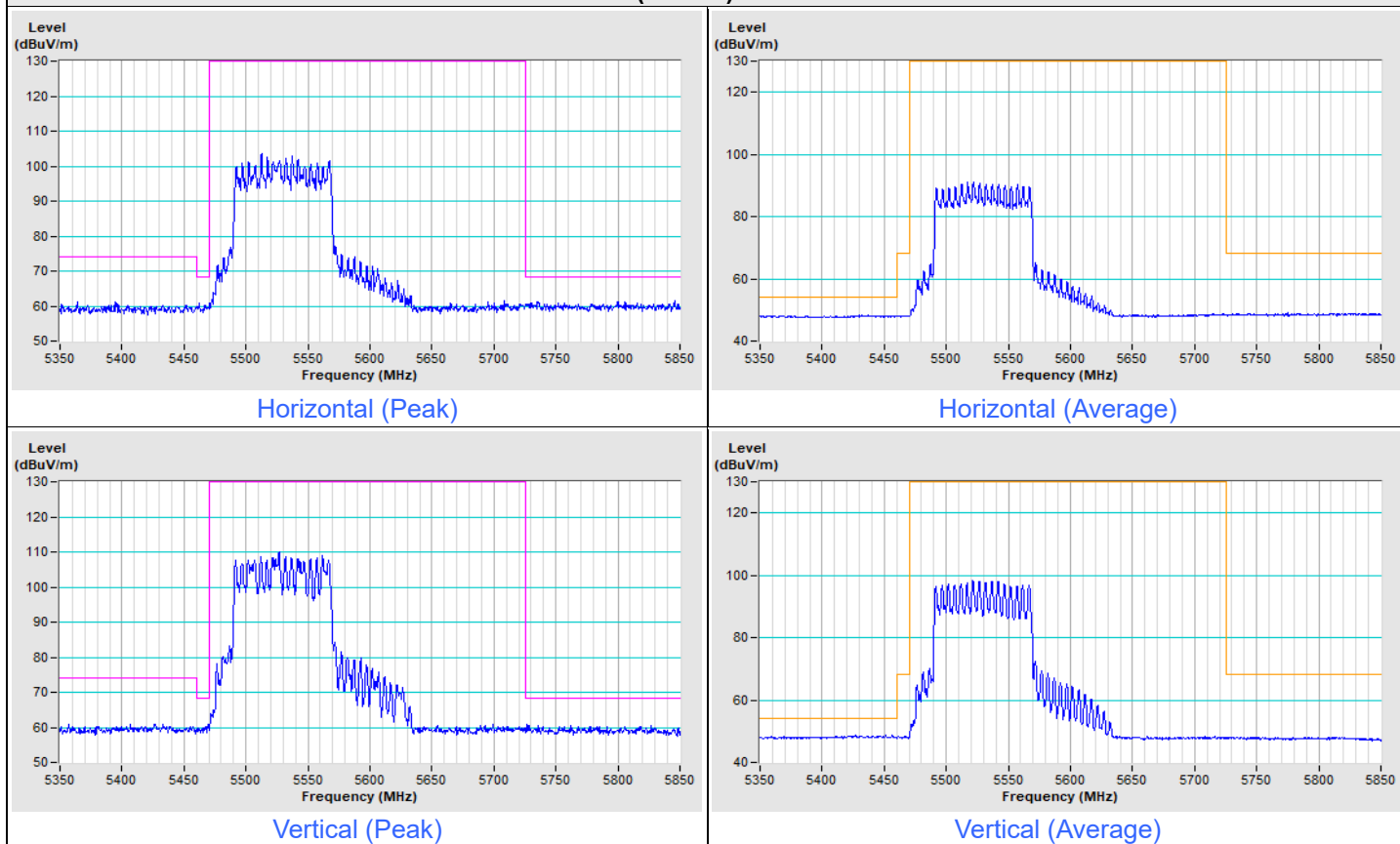

802.11be (EHT80) Channel 122

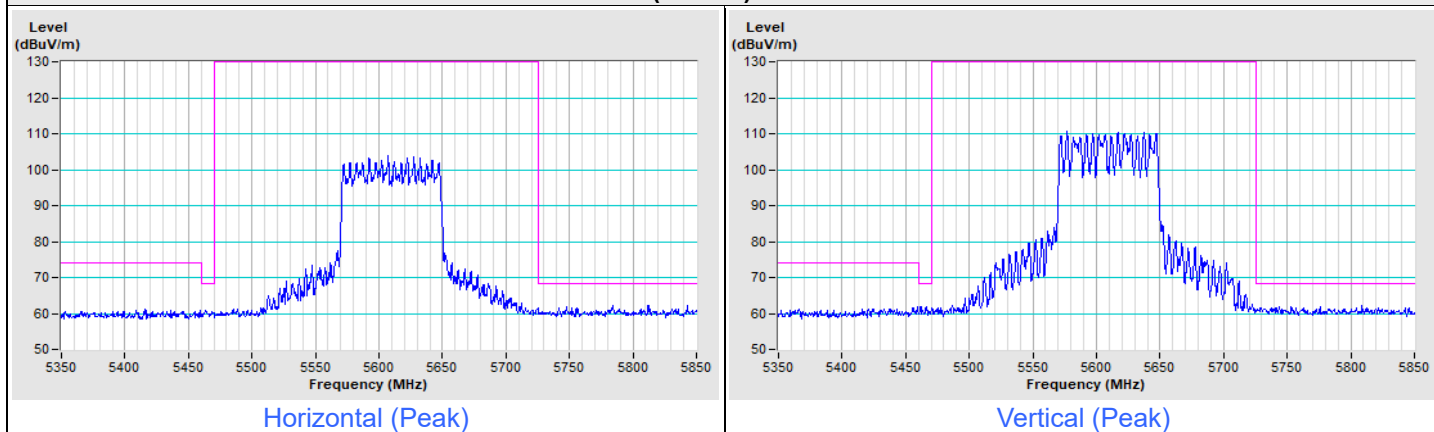

Frequency Range	5.35 GHz ~ 5.95 GHz	Detector Function & Bandwidth	PK: RB=1 MHz, VB=3 MHz, DET=Peak
-----------------	---------------------	-------------------------------	----------------------------------

802.11be (EHT80) Channel 138

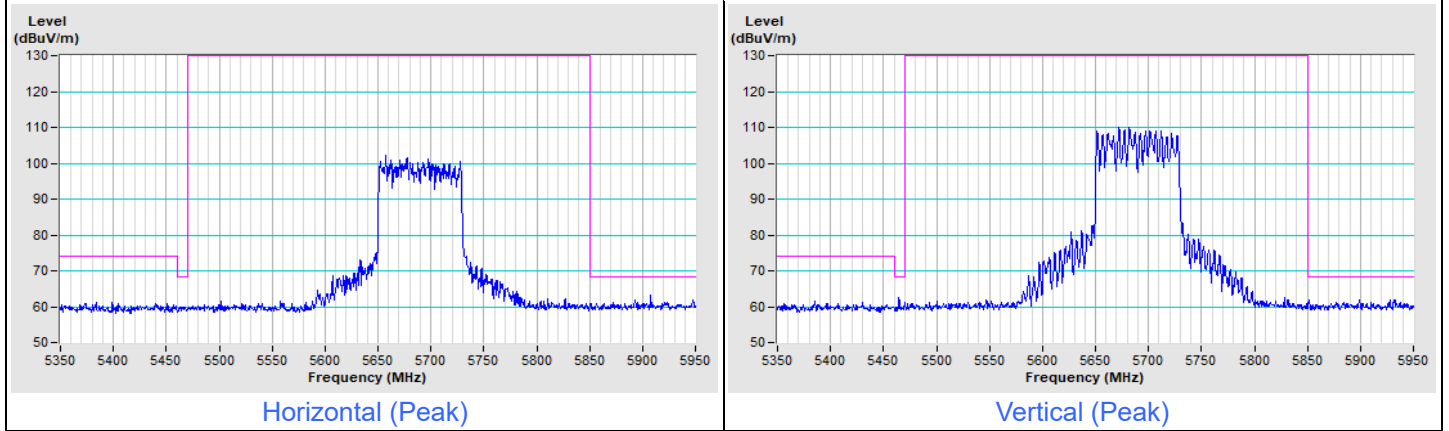

Frequency Range	5.6 GHz ~ 6 GHz	Detector Function & Bandwidth	PK: RB=1 MHz, VB=3 MHz, DET=Peak
-----------------	-----------------	-------------------------------	----------------------------------

802.11be (EHT80) Channel 155

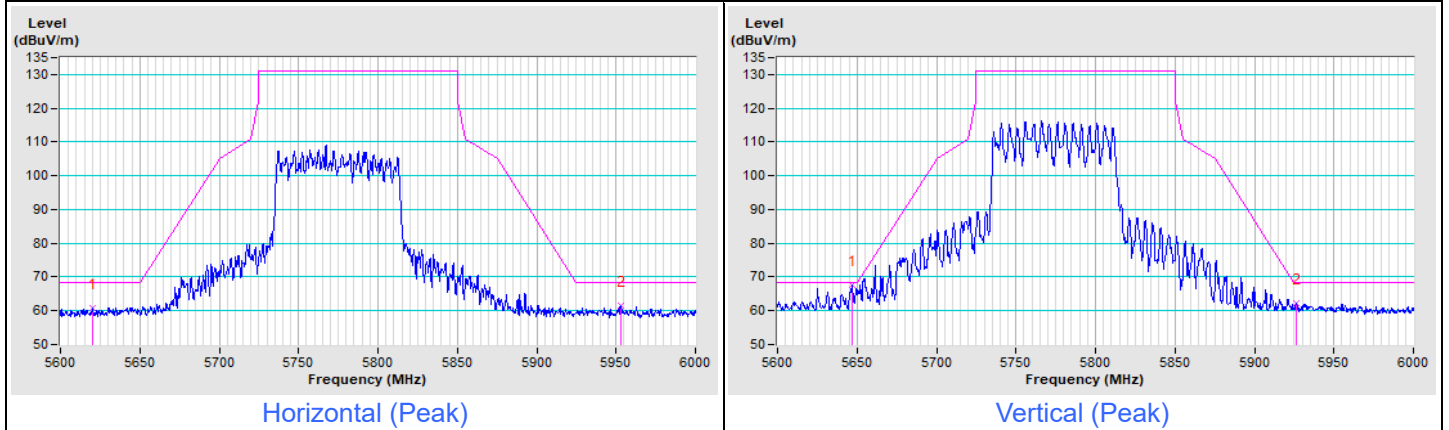

Frequency Range	4.5 GHz ~ 5.46 GHz	Detector Function & Bandwidth	PK: RB=1 MHz, VB=3 MHz, DET=Peak AV: RB=1 MHz, VB=10 Hz, DET=Peak
-----------------	--------------------	-------------------------------	--

802.11be (EHT160) Channel 50

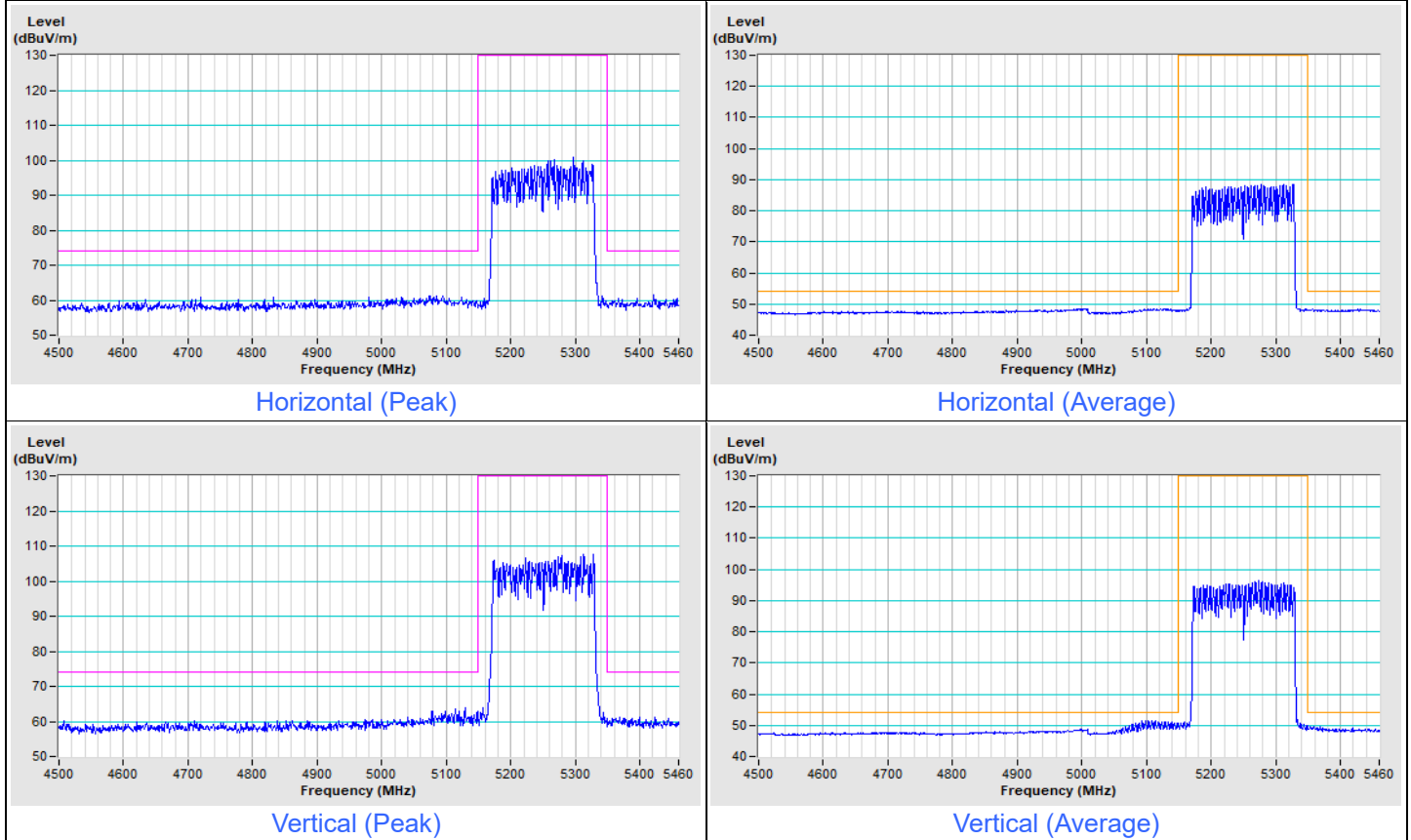

Frequency Range	5.35 GHz ~ 5.85 GHz	Detector Function & Bandwidth	PK: RB=1 MHz, VB=3 MHz, DET=Peak AV: RB=1 MHz, VB=10 Hz, DET=Peak
-----------------	---------------------	-------------------------------	--

802.11be (EHT160) Channel 114

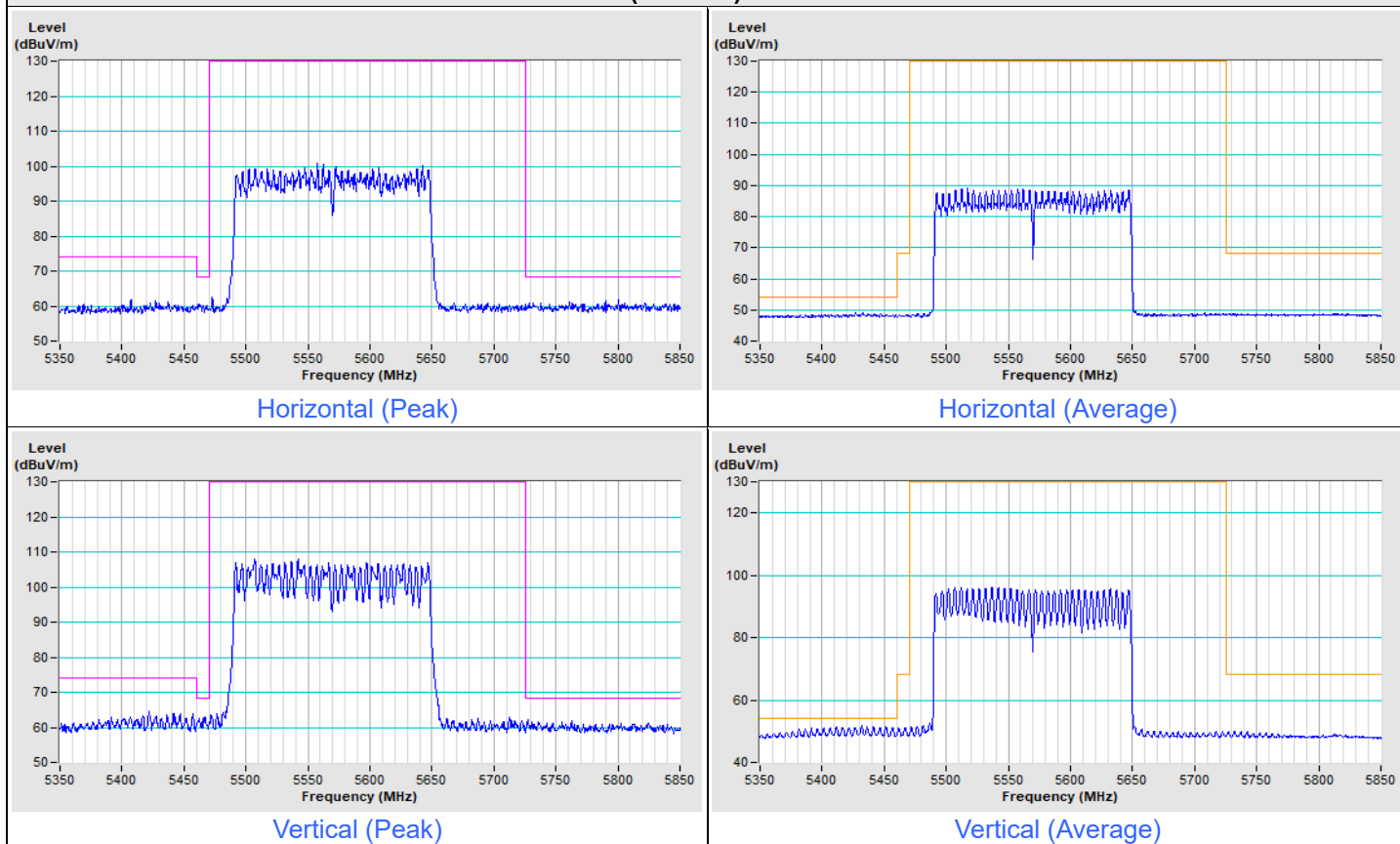

8 Pictures of Test Arrangements

Please refer to the attached file (Test Setup Photo)

9 Information of the Testing Laboratories

We, Bureau Veritas Consumer Products Services (H.K.) Ltd., Taoyuan Branch, were founded in 1988 to provide our best service in EMC, Radio, Telecom and Safety consultation. Our laboratories are FCC recognized accredited test firms and accredited according to ISO/IEC 17025.

If you have any comments, please feel free to contact us at the following:

Lin Kou EMC/RF Lab

Tel: 886-2-26052180

Fax: 886-2-26051924

Hsin Chu EMC/RF/Telecom Lab

Tel: 886-3-6668565

Fax: 886-3-6668323

Hwa Ya EMC/RF/Safety Lab

Tel: 886-3-3183232

Fax: 886-3-3270892

Email: service.adt@bureauveritas.com

Web Site: <http://ee.bureauveritas.com.tw>

The address and road map of all our labs can be found in our web site also.

--- END ---