

TEST REPORT

CERTIFICATE OF CONFORMITY

Standard: 47 CFR FCC Part 15, Subpart E (Section 15.407)

Report No.: RFBBQZ-WTW-P24010702-3

FCC ID: PY323400612

Product: NIGHTHAWK BE18000 WiFi 7 Router

Brand: NETGEAR

Model No.: RS600

Received Date: 2024/2/2

Test Date: 2024/5/30 ~ 2024/6/7

Issued Date: 2024/7/1

Applicant and Manufacturer: NETGEAR, INC.

Address: 350 East Plumeria Drive San Jose CA 95134

Issued By: Bureau Veritas Consumer Products Services (H.K.) Ltd., Taoyuan Branch
Lin Kou Laboratories

Lab Address: No. 47-2, 14th Ling, Chia Pau Vil., Lin Kou Dist., New Taipei City, Taiwan

Test Location: No. 19, Hwa Ya 2nd Rd., Wen Hwa Vil., Kewi Shan Dist., Taoyuan City 33383, Taiwan

FCC Registration /

Designation Number: 788550 / TW0003

Approved by: _____

Jeremy Lin

Date: _____

2024/7/1

Jeremy Lin / Project Engineer

This test report consists of 56 pages in total. It may be duplicated completely for legal use with the approval of the applicant. It should not be reproduced except in full, without the written approval of our laboratory. The test results in the report only apply to the tested sample. The test results in this report are traceable to the national or international standards.



Prepared by : Celine Chou / Senior Specialist

This report is governed by, and incorporates by reference, the Conditions of Testing as posted at the date of issuance of this report at <http://www.bureauveritas.com/home/about-us/our-business/cps/about-us/terms-conditions/> and is intended for your exclusive use. Any copying or replication of this report to or for any other person or entity, or use of our name or trademark, is permitted only with our prior written permission. This report sets forth our findings solely with respect to the test samples identified herein. The results set forth in this report are not indicative or representative of the quality or characteristics of the lot from which a test sample was taken or any similar or identical product unless specifically and expressly noted. Our report includes all of the tests requested by you and the results thereof based upon the information that you provided to us. Measurement uncertainty is only provided upon request for accredited tests. Statements of conformity are based on simple acceptance criteria without taking measurement uncertainty into account, unless otherwise requested in writing. You have 60 days from date of issuance of this report to notify us of any material error or omission caused by our negligence or if you require measurement uncertainty; provided, however, that such notice shall be in writing and shall specifically address the issue you wish to raise. A failure to raise such issue within the prescribed time shall constitute your unqualified acceptance of the completeness of this report, the tests conducted and the correctness of the report contents.

Table of Contents

Release Control Record	4
1 Certificate	5
2 Summary of Test Results	6
2.1 Measurement Uncertainty	6
2.2 Supplementary Information	6
3 General Information	7
3.1 General Description of EUT	7
3.2 Antenna Description of EUT	9
3.3 Channel List	10
3.4 Test Mode Applicability and Tested Channel Detail	11
3.5 Duty Cycle of Test Signal	12
3.6 Test Program Used and Operation Descriptions	14
3.7 Connection Diagram of EUT and Peripheral Devices	14
3.8 Configuration of Peripheral Devices and Cable Connections	14
4 Test Instruments	15
4.1 RF Output Power	15
4.2 Power Spectral Density	15
4.3 6 dB Bandwidth	15
4.4 Frequency Stability	16
4.5 AC Power Conducted Emissions	16
4.6 Unwanted Emissions below 1 GHz	17
4.7 Unwanted Emissions above 1 GHz	18
5 Limits of Test Items	19
5.1 RF Output Power	19
5.2 Power Spectral Density	19
5.3 6 dB Bandwidth	19
5.4 Frequency Stability	19
5.5 AC Power Conducted Emissions	19
5.6 Unwanted Emissions below 1 GHz	20
5.7 Unwanted Emissions above 1 GHz	20
6 Test Arrangements	21
6.1 RF Output Power	21
6.1.1 Test Setup	21
6.1.2 Test Procedure	21
6.2 Power Spectral Density	22
6.2.1 Test Setup	22
6.2.2 Test Procedure	22
6.3 6 dB Bandwidth	23
6.3.1 Test Setup	23
6.3.2 Test Procedure	23
6.4 Frequency Stability	23
6.4.1 Test Setup	23
6.4.2 Test Procedure	23
6.5 AC Power Conducted Emissions	24
6.5.1 Test Setup	24
6.5.2 Test Procedure	24
6.6 Unwanted Emissions below 1 GHz	25
6.6.1 Test Setup	25
6.6.2 Test Procedure	26
6.7 Unwanted Emissions above 1 GHz	27
6.7.1 Test Setup	27
6.7.2 Test Procedure	27
7 Test Results of Test Item	28



7.1	RF Output Power.....	28
7.2	Power Spectral Density.....	30
7.3	6 dB Bandwidth.....	33
7.4	Frequency Stability.....	35
7.5	AC Power Conducted Emissions.....	36
7.6	Unwanted Emissions below 1 GHz.....	38
7.7	Unwanted Emissions above 1 GHz.....	40
8	Pictures of Test Arrangements.....	55
9	Information of the Testing Laboratories.....	56

Release Control Record

Issue No.	Description	Date Issued
RFBBQZ-WTW-P24010702-3	Original release.	2024/7/1

1 Certificate

Product: NIGHTHAWK BE18000 WiFi 7 Router

Brand: NETGEAR

Test Model: RS600

Sample Status: Engineering sample

Applicant and Manufacturer: NETGEAR, INC.

Test Date: 2024/5/30 ~ 2024/6/7

Standard: 47 CFR FCC Part 15, Subpart E (Section 15.407)

Measurement procedure: ANSI C63.10-2013

KDB 291074 D02 EMC Measurement v01

KDB 789033 D02 General UNII Test Procedure New Rules v02r01

KDB 662911 D01 Multiple Transmitter Output v02r01

The above equipment has been tested by **Bureau Veritas Consumer Products Services (H.K.) Ltd., Taoyuan Branch**, and found compliance with the requirement of the above standards. The test record, data evaluation & Equipment Under Test (EUT) configurations represented herein are true and accurate accounts of the measurements of the sample's RF characteristics under the conditions specified in this report.

2 Summary of Test Results

47 CFR FCC Part 15, Subpart E (Section 15.407)			
Clause	Test Item	Result	Remark
15.407(a)(3)	RF Output Power	Pass	Meet the requirement of limit.
15.407(a)(3)	Power Spectral Density	Pass	Meet the requirement of limit.
15.407(b)(9)	AC Power Conducted Emissions	Pass	Minimum passing margin is -18.64 dB at 0.18037 MHz
15.407(b)(9)	Unwanted Emissions below 1 GHz	Pass	Minimum passing margin is -3.8 dB at 60.07 MHz
15.407(b)(5) 15.407(b)(10)	Unwanted Emissions above 1 GHz	Pass	Minimum passing margin is -0.5 dB at 5650.00 MHz
15.407(e)	6 dB Bandwidth	Pass	Meet the requirement of limit.
15.407(g)	Frequency Stability	Pass	Meet the requirement of limit.
15.203	Antenna Requirement	Pass	Antenna connector is ipex(MHF) not a standard connector.

Note: Determining compliance based on the results of the compliance measurement, not taking into account measurement instrumentation uncertainty.

2.1 Measurement Uncertainty

Where relevant, the following measurement uncertainty levels have been estimated for tests performed on the EUT as specified in CISPR 16-4-2:

Parameter	Specification	Uncertainty (±)
RF Output Power	1 GHz ~ 18 GHz	2.29 dB
Power Spectral Density	1 GHz ~ 18 GHz	2.29 dB
6 dB Bandwidth	-	206.5 Hz
Frequency Stability	-	0.176 ppm
AC Power Conducted Emissions	9 kHz ~ 30 MHz	2.90 dB
Unwanted Emissions below 1 GHz	9 kHz ~ 30 MHz	3.59 dB
	30 MHz ~ 1 GHz	3.64 dB
Unwanted Emissions above 1 GHz	1 GHz ~ 18 GHz	2.29 dB
	18 GHz ~ 40 GHz	2.29 dB

The other instruments specified are routine verified to remain within the calibrated levels, no measurement uncertainty is required to be calculated.

2.2 Supplementary Information

There is not any deviation from the test standards for the test method, and no modifications required for compliance.

3 General Information

3.1 General Description of EUT

Product	NIGHTHAWK BE18000 WiFi 7 Router
Brand	NETGEAR
Test Model	RS600
Status of EUT	Engineering sample
Power Supply Rating	19 Vdc from adapter
Modulation Type	64QAM, 16QAM, QPSK, BPSK for OFDM 256QAM for OFDM in 11ac mode 1024QAM for OFDMA in 11ax mode 4096QAM for OFDMA in 11be mode
Modulation Technology	OFDM, OFDMA
Transfer Rate	Up to 5764 Mbps
Operating Frequency	5.815 GHz ~ 5.885 GHz
Number of Channel	802.11a, 802.11n (HT20), 802.11ac (VHT20), 802.11ax (HE20), 802.11be (EHT20):3 802.11n (HT40), 802.11ac (VHT40), 802.11ax (HE40), 802.11be (EHT40):2 802.11ac (VHT80), 802.11ax (HE80), 802.11be (EHT80):1 802.11ac (VHT160), 802.11ax (HE160), 802.11be (EHT160):1
Output Power	EIRP: 3854.784 mW (35.86 dBm)

Note:

1. The EUT uses following accessories.

AC Adapter 1			
Brand	Model	Part Number	Specification
NETGEAR	ADS-65GNC-19 19065E	332-11720-01	AC Input: 100-240 Vac, 50/60 Hz, 1.5 A DC Output: 19 Vdc, 3.42 A, 64.98 W DC Output Cable: 1.8 m / 0 core Plug: US/EU/AU Manufacturer: Vietnam Honor High Tech Company Limited
AC Adapter 2			
Brand	Model	Part Number	Specification
NETGEAR	G1A065KC	332-11718-01	AC Input: 100-240 Vac, 50/60 Hz, 1.5 A DC Output: 19 Vdc, 3.42 A, 65.0W DC Output Cable: 1.85 m / 0 core Plug: US/EU/AU Manufacturer: Power Plus Technology (Vietnam) Corp
Ethernet Cable			
Brand	Model	Specification	
NETGEAR	N/A	Signal Line: 1.95 m	

2. Simultaneously transmission condition.

Condition	Technology		
1	WLAN (2.4GHz)	WLAN (5GHz)	WLAN (6GHz)

Note: The emission of the simultaneous operation has been evaluated and no non-compliance was found.

3. The EUT has two difference pin-to-pin DR Filter, after pretest the 1st filter was worst case for final test

DR Filter	Description
1st DR Filter	DFJ6610CA30 (SY01166101J91F31C)
2nd DR Filter	DFJ6610DA30 (SY01166101J91H41C)

4. The above EUT information is declared by manufacturer and for more detailed features description, please refer to the manufacturer's specifications or user's manual.

3.2 Antenna Description of EUT

1. The antenna information is listed as below.

Antenna No.	Gain (dBi)	Antenna Type	Connector Type
	5850 MHz		
Ant. 0	3.78	Dipole	ipex(MHF)
Ant. 1	3.84	Dipole	ipex(MHF)
Ant. 2	4.20	Dipole	ipex(MHF)
Ant. 3	3.00	Dipole	ipex(MHF)

* Detail antenna specification please refer to antenna datasheet and/or antenna measurement report.

2. The EUT incorporates a MIMO function:

Modulation Mode	Tx & Rx Configuration	
802.11a	4TX	4RX
802.11n (HT20)	4TX	4RX
802.11n (HT40)	4TX	4RX
802.11ac (VHT20)	4TX	4RX
802.11ac (VHT40)	4TX	4RX
802.11ac (VHT80)	4TX	4RX
802.11ac (VHT160)	4TX	4RX
802.11ax (HE20)	4TX	4RX
802.11ax (HE40)	4TX	4RX
802.11ax (HE80)	4TX	4RX
802.11ax (HE160)	4TX	4RX
802.11be (EHT20)	4TX	4RX
802.11be (EHT40)	4TX	4RX
802.11be (EHT80)	4TX	4RX
802.11be (EHT160)	4TX	4RX

Note:

1. All of modulation mode support beamforming function except 802.11a modulation mode.
2. The EUT support Beamforming and CDD mode, therefore both mode were investigated and the worst case scenario was identified. The worst case data were presented in test report.
3. The modulation and bandwidth are similar for 802.11n mode for 20 MHz (40 MHz), 802.11ac mode for 20 MHz (40 MHz, 80 MHz, 160MHz), 802.11ax mode for 20 MHz (40 MHz, 80 MHz, 160MHz), and 802.11be mode for 20 MHz (40 MHz, 80 MHz, 160MHz), therefore the manufacturer will control the power for 802.11n/ac/ax mode is the same as the 802.11be or lower than it and investigated worst case to representative mode in test report.
4. For 802.11ax/be, the EUT not support Partial RU (resource unit) and channel puncturing/bandwidth reduction mechanisms.

3.3 Channel List

3 channels are provided for 802.11a, 802.11n (HT20), 802.11ac (VHT20), 802.11ax (HE20), 802.11be (EHT20):

Channel	Frequency	Channel	Frequency	Channel	Frequency
*169	5845 MHz	173	5865 MHz	177	5885 MHz

2 channels are provided for 802.11n (HT40), 802.11ac (VHT40), 802.11ax (HE40), 802.11be (EHT40):

Channel	Frequency	Channel	Frequency
*167	5835 MHz	175	5875 MHz

1 channel is provided for 802.11ac (VHT80), 802.11ax (HE80), 802.11be (EHT80):

Channel	Frequency
*171	5855 MHz

1 channel is provided for 802.11ac (VHT160), 802.11ax (HE160), 802.11be (EHT160):

Channel	Frequency
*163	5815 MHz

Note: * U-NII-3 & -4 span channels.

3.4 Test Mode Applicability and Tested Channel Detail

Pre-Scan:	<ol style="list-style-type: none"> For Unwanted Emission (below 1GHz) and AC Power Conducted Emissions items: AC Adapter 1 and AC Adapter 2. Pre-scan these modes and find the worst case as a representative test condition. Pre-Scan has been conducted to determine the worst-case mode from all possible combinations between available modulations, data rates and antenna ports (if EUT with antenna diversity architecture).
Worst Case:	<ol style="list-style-type: none"> AC Adapter 1 and AC Adapter 2 Worst Condition: AC Adapter 2 The EUT is designed to be positioned on the Z-Plane only.

Following channel(s) was (were) selected for the final test as listed below:

Test Item	Mode	Signal Mode	Tested Channel	Modulation	Data Rate Parameter
RF Output Power	802.11a	CDD	169, 173, 177	BPSK	6Mb/s
	802.11be (EHT20)	Beamforming	169, 173, 177	BPSK	MCS0
	802.11be (EHT40)	Beamforming	167, 175	BPSK	MCS0
	802.11be (EHT80)	Beamforming	171	BPSK	MCS0
	802.11be (EHT160)	Beamforming	163	BPSK	MCS0
Power Spectral Density	802.11a	CDD	169, 173, 177	BPSK	6Mb/s
	802.11be (EHT20)	Beamforming	169, 173, 177	BPSK	MCS0
	802.11be (EHT40)	Beamforming	167, 175	BPSK	MCS0
	802.11be (EHT80)	Beamforming	171	BPSK	MCS0
	802.11be (EHT160)	Beamforming	163	BPSK	MCS0
6 dB Bandwidth	802.11a	CDD	169, 173, 177	BPSK	6Mb/s
	802.11be (EHT20)	Beamforming	169, 173, 177	BPSK	MCS0
	802.11be (EHT40)	Beamforming	167, 175	BPSK	MCS0
	802.11be (EHT80)	Beamforming	171	BPSK	MCS0
	802.11be (EHT160)	Beamforming	163	BPSK	MCS0
Frequency Stability	802.11a	-	177	un-modulation	-
AC Power Conducted Emissions	802.11be (EHT40)	Beamforming	167	BPSK	MCS0
Unwanted Emissions below 1 GHz	802.11be (EHT40)	Beamforming	167	BPSK	MCS0
Unwanted Emissions above 1 GHz	802.11a	CDD	169, 173, 177	BPSK	6Mb/s
	802.11be (EHT20)	Beamforming	169, 173, 177	BPSK	MCS0
	802.11be (EHT40)	Beamforming	167, 175	BPSK	MCS0
	802.11be (EHT80)	Beamforming	171	BPSK	MCS0
	802.11be (EHT160)	Beamforming	163	BPSK	MCS0

Note: Partial RU (resource unit), channel puncturing and bandwidth reduction mechanisms are not supported.

3.5 Duty Cycle of Test Signal

802.11a: Duty cycle = 3.02 ms / 3.04 ms x 100% = 99.3%

802.11be (EHT20): Duty cycle = 2.87 ms / 2.89 ms x 100% = 99.3%

802.11be (EHT40): Duty cycle = 2.86 ms / 2.87 ms x 100% = 99.7%

802.11be (EHT80): Duty cycle = 2.86 ms / 2.87 ms x 100% = 99.7%

802.11be (EHT160): Duty cycle = 2.85 ms / 2.87 ms x 100% = 99.3%

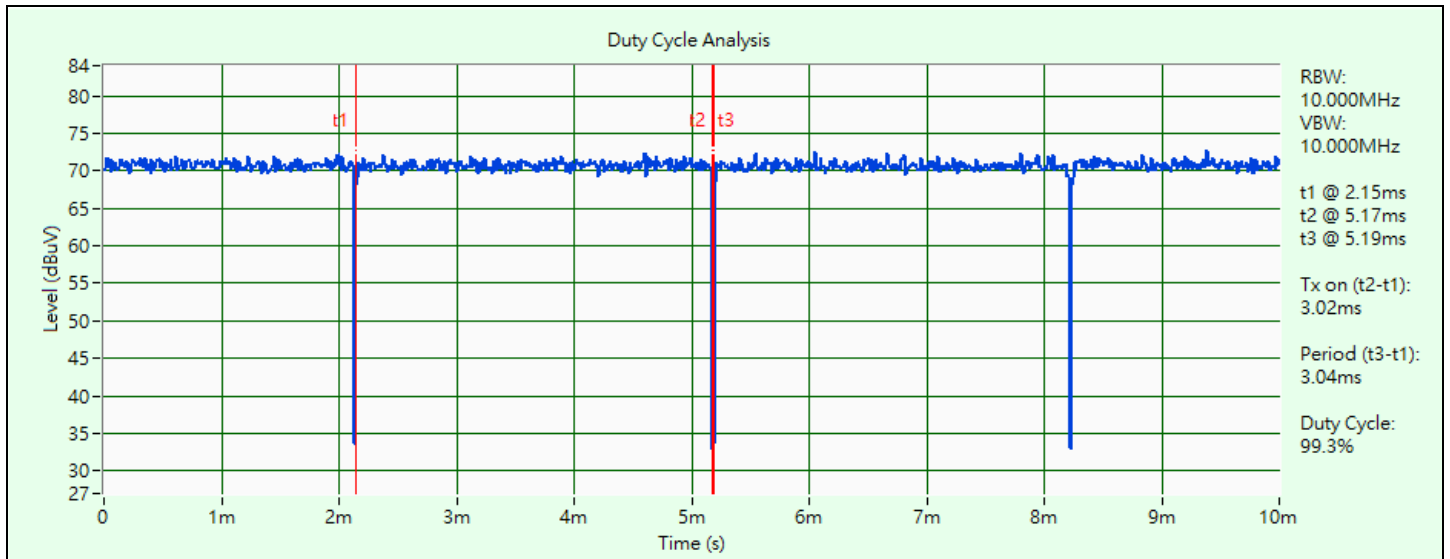

802.11a

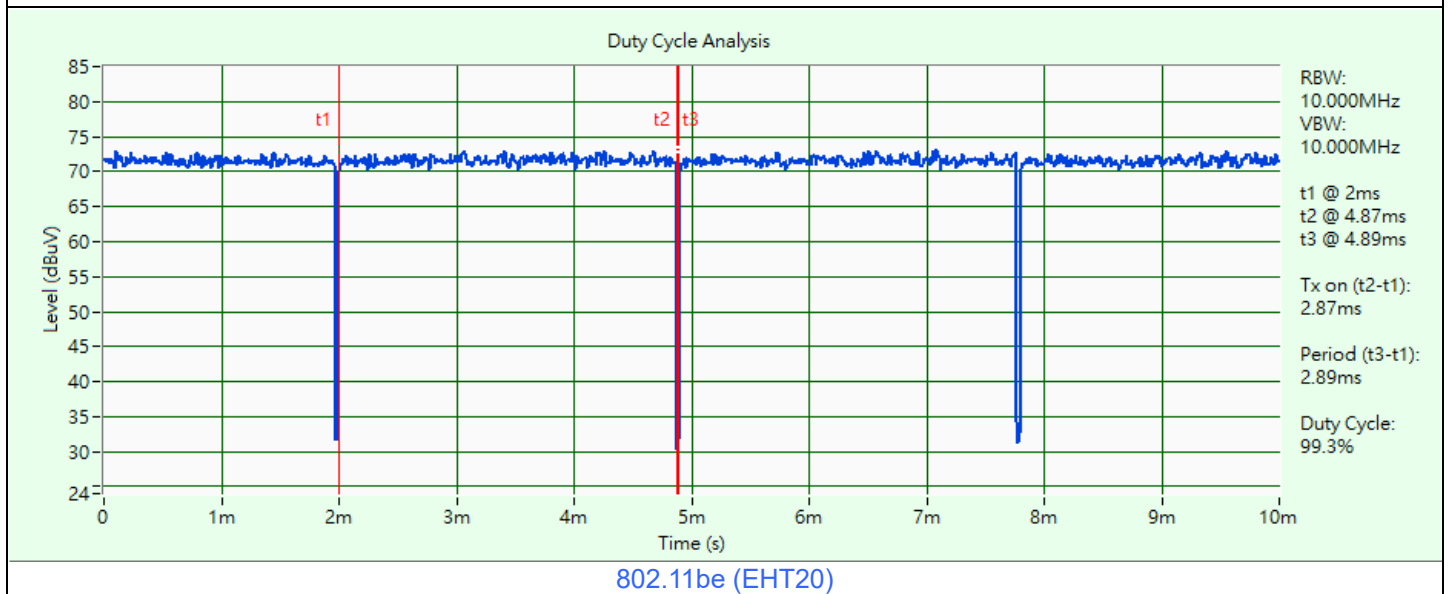

802.11be (EHT20)

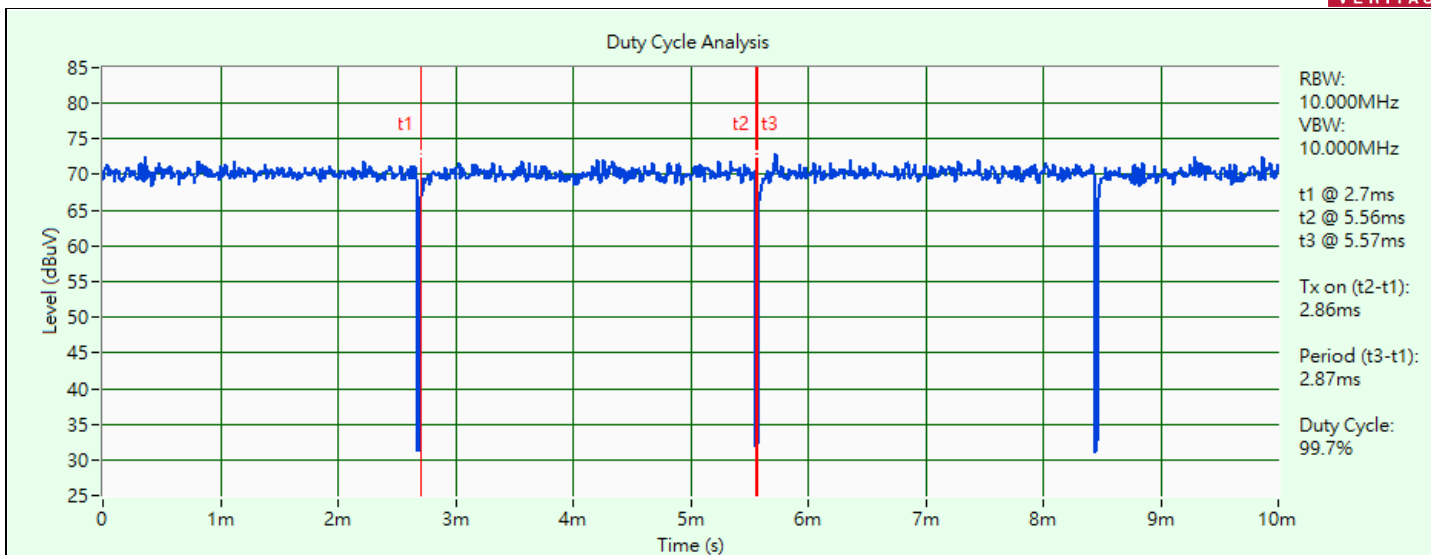

802.11be (EHT40)

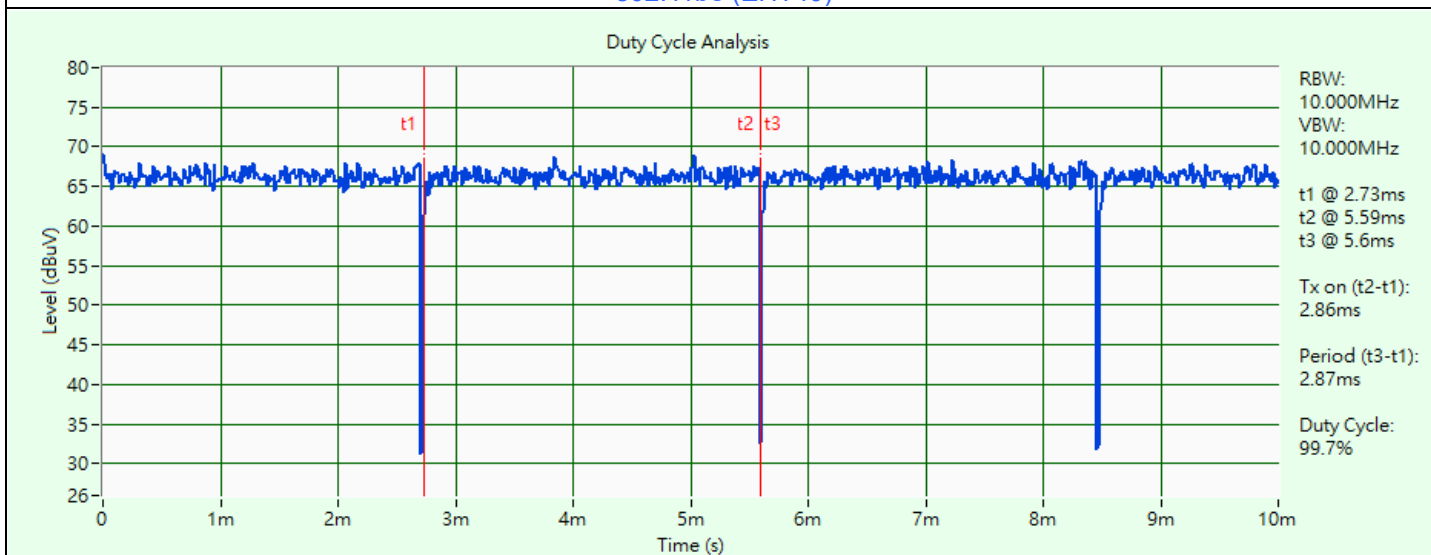

802.11be (EHT80)

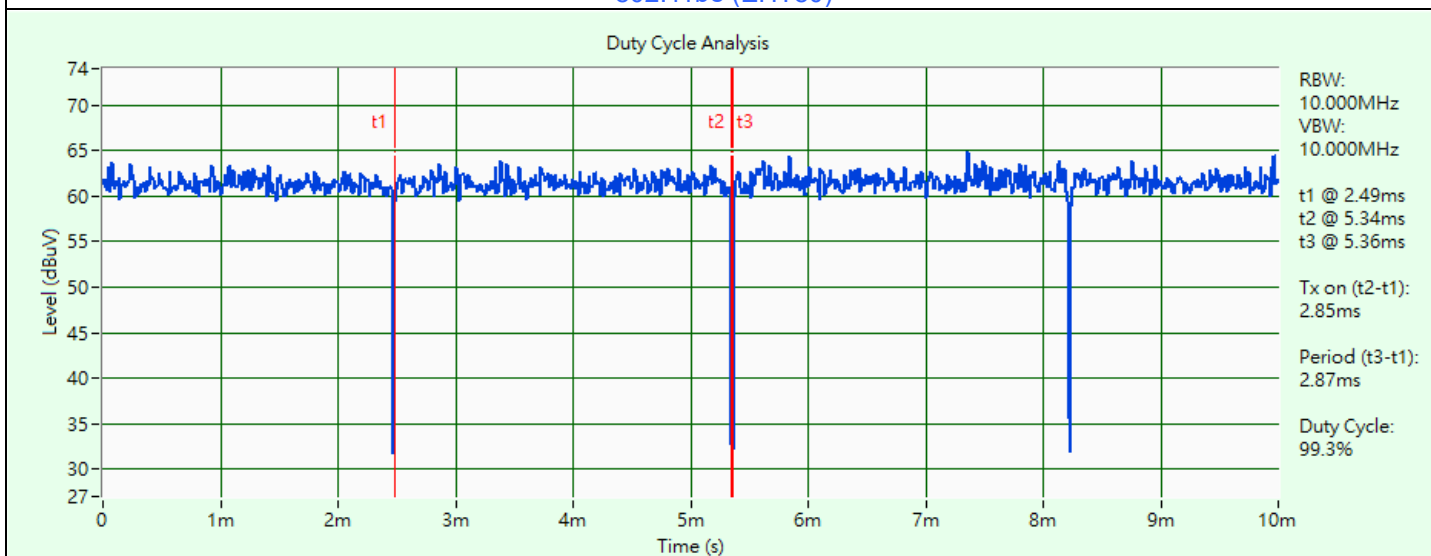

802.11be (EHT160)

3.6 Test Program Used and Operation Descriptions

Controlling software accessMTool_REL_3_2_1_5 has been activated to set the EUT under transmission condition continuously at specific channel frequency.

3.7 Connection Diagram of EUT and Peripheral Devices

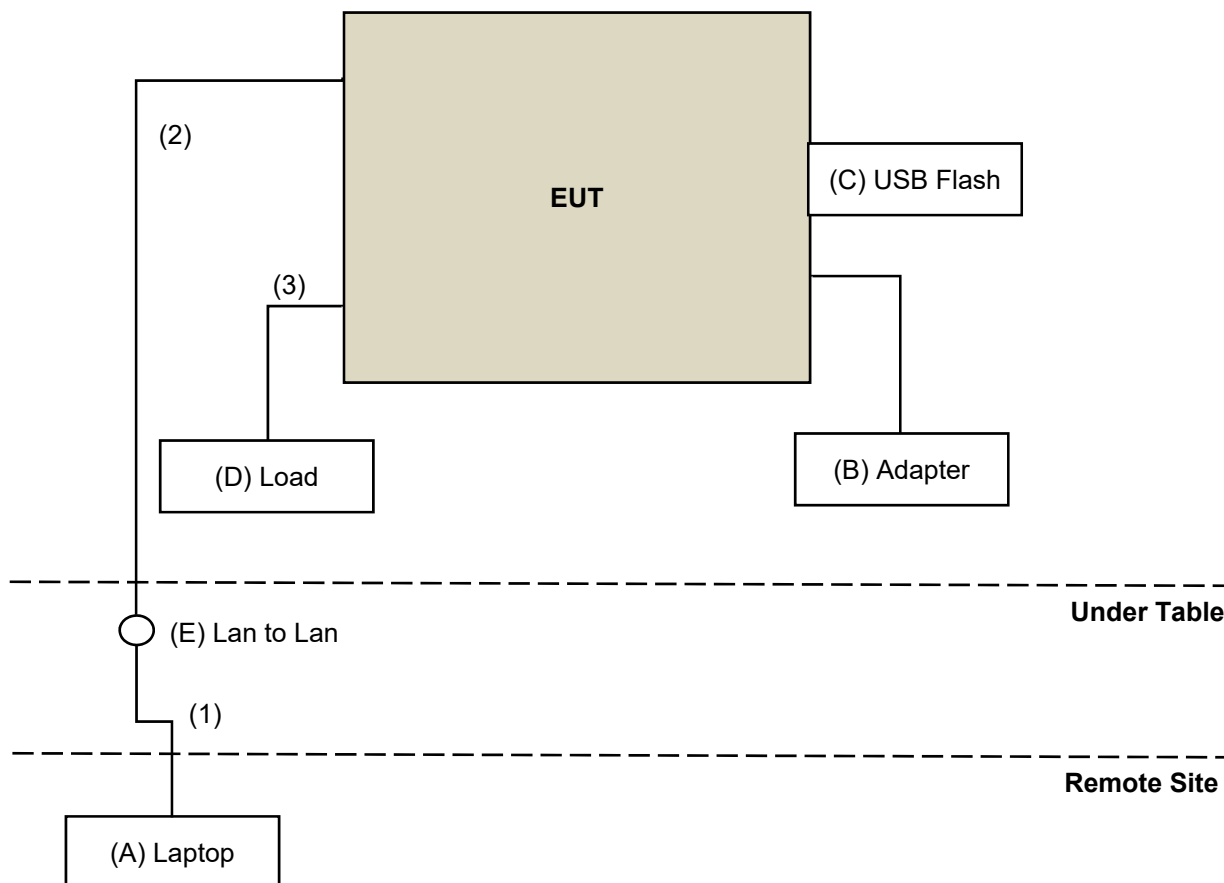

3.8 Configuration of Peripheral Devices and Cable Connections

ID	Product	Brand	Model No.	Serial No.	FCC ID	Remarks
A	Laptop	DELL	E5430	2RL3YW1	N/A	Provided by Lab
B	Adapter	NETGEAR	G1A065KC	N/A	N/A	Accessory of EUT
C	USB Flash	SanDisk	SDDDC3-032G	N/A	N/A	Provided by Lab
D	Lord	N/A	N/A	N/A	N/A	Provided by Lab
E	Lan to Lan	N/A	N/A	N/A	N/A	Provided by Lab

ID	Cable Descriptions	Qty.	Length (m)	Shielding (Yes/No)	Cores (Qty.)	Remarks
1	RJ-45 Cable	1	10	N	N	Provided by Lab
2	RJ-45 Cable	1	1.95	N	N	Accessory of EUT
3	RJ-45 Cable	4	1.5	N	N	Provided by Lab

4 Test Instruments

The calibration interval of the all test instruments are 12 months and the calibrations are traceable to NML/ROC and NIST/USA.

4.1 RF Output Power

Description Manufacturer	Model No.	Serial No.	Calibrated Date	Calibrated Until
Antenna Tower inn-co GmbH	MA 4000	010303	N/A	N/A
EMI Test Receiver R&S	ESR3	102782	2023/12/7	2024/12/6
Horn Antenna Schwarzbeck	BBHA 9120D	9120D-408	2023/11/12	2024/11/11
Preamplifier Keysight	83017A	MY53270295	2024/5/1	2025/4/30
RF Coaxial Cable HUBER+SUHNER	SUCOFLEX 104	Cable-CH4-03(250724)	2024/5/1	2025/4/30
	Sucoflex 104	MY 13380+295012/04	2024/5/1	2025/4/30
Signal & Spectrum Analyzer R&S	FSW43	101582	2024/4/12	2025/4/11
Software BV ADT	ADT_Radiated_ V7.6.15.9.5	N/A	N/A	N/A
Turn Table BV ADT	TT100	TT93021705	N/A	N/A
Turn Table Controller BV ADT	SC100	SC93021705	N/A	N/A

Notes:

1. The test was performed in HY - 966 chamber 3.
2. Tested Date: 2024/6/3 ~ 2024/6/7

4.2 Power Spectral Density

Refer to section 4.1 to get the tested date and information of the instruments.

4.3 6 dB Bandwidth

Description Manufacturer	Model No.	Serial No.	Calibrated Date	Calibrated Until
Signal & Spectrum Analyzer R&S	FSV3044	101105	2024/2/27	2025/2/26
Software BV	ADT_RF Test Software V7.6.5.4	N/A	N/A	N/A

Notes:

1. The test was performed in Oven room.
2. Tested Date: 2024/6/3 ~ 2024/6/7

4.4 Frequency Stability

Description Manufacturer	Model No.	Serial No.	Calibrated Date	Calibrated Until
AC Power Supply JIN YIH Technology	6905S	1720444	N/A	N/A
Digital Multimeter Fluke	87III	70360742	2023/7/6	2024/7/5
Signal & Spectrum Analyzer R&S	FSV3044	101105	2024/2/27	2025/2/26
Software BV	ADT_RF Test Software V7.6.5.4	N/A	N/A	N/A
Temperature & Humidity Chamber Terchy	HRM-120RF	931022	2023/12/19	2024/12/18

Notes:

1. The test was performed in Oven room.
2. Tested Date: 2024/6/3 ~ 2024/6/7

4.5 AC Power Conducted Emissions

Description Manufacturer	Model No.	Serial No.	Calibrated Date	Calibrated Until
50 ohm terminal resistance HUBER+SUHNER	E1-011315	13	2023/11/22	2024/11/21
50 ohm terminal resistance	E1-011279	04	2023/11/22	2024/11/21
	E1-011280	05	2023/11/22	2024/11/21
DC-LISN Schwarzbeck	NNBM 8126G	8126G-069	2023/11/7	2024/11/6
EMI Test Receiver R&S	ESCI	100613	2023/12/4	2024/12/3
Fixed Attenuator Mini-Circuits	HAT-10+	PAD-COND1-01	2024/1/6	2025/1/5
LISN R&S	ENV216	101826	2024/3/25	2025/3/24
	ESH3-Z5	100311	2023/9/6	2024/9/5
RF Coaxial Cable Woken	5D-FB	Cable-cond1-01	2024/1/6	2025/1/5
Software BVADT	BVADT_Cond_ V7.4.1.0	N/A	N/A	N/A
V-LISN Schwarzbeck	NNBL 8226-2	8226-142	2023/8/31	2024/8/30

Notes:

1. The test was performed in HY - Conduction 1.
2. Tested Date: 2024/6/5

4.6 Unwanted Emissions below 1 GHz

Description Manufacturer	Model No.	Serial No.	Calibrated Date	Calibrated Until
Antenna Tower inn-co GmbH	MA 4000	010303	N/A	N/A
Bi_Log Antenna Schwarzbeck	VULB 9168	9168-155	2023/10/13	2024/10/12
EMI Test Receiver R&S	ESR3	102782	2023/12/7	2024/12/6
Loop Antenna Electro-Metrics	EM-6879	269	2023/9/23	2024/9/22
Loop Antenna TESEQ	HLA 6121	45745	2023/8/8	2024/8/7
Preamplifier Agilent	8447D	2944A10631	2024/5/1	2025/4/30
Preamplifier EMCI	EMC001340	980201	2023/9/27	2024/9/26
RF Coaxial Cable Woken	8D-FB	Cable-CH4-01	2023/7/8	2024/7/7
Signal & Spectrum Analyzer R&S	FSW43	101582	2024/4/12	2025/4/11
Software BV ADT	ADT_Radiated_ V7.6.15.9.5	N/A	N/A	N/A
Turn Table BV ADT	TT100	TT93021705	N/A	N/A
Turn Table Controller BV ADT	SC100	SC93021705	N/A	N/A

Notes:

1. The test was performed in HY - 966 chamber 3.
2. Tested Date: 2024/6/7

4.7 Unwanted Emissions above 1 GHz

Description Manufacturer	Model No.	Serial No.	Calibrated Date	Calibrated Until
Antenna Tower inn-co GmbH	MA 4000	010303	N/A	N/A
Boresight antenna tower fixture BV	BAF-02	5	N/A	N/A
EMI Test Receiver R&S	ESR3	102782	2023/12/7	2024/12/6
Horn Antenna Schwarzbeck	BBHA 9120D	9120D-408	2023/11/12	2024/11/11
	BBHA 9170	9170-480	2023/11/12	2024/11/11
		BBHA9170241	2023/10/16	2024/10/15
		BBHA9170243	2023/11/12	2024/11/11
Preamplifier EMCI	EMC 184045	980116	2023/9/27	2024/9/26
Preamplifier Keysight	83017A	MY53270295	2024/5/1	2025/4/30
RF Coaxial Cable EMCI	EMC102-KM-KM-600	150928	2023/7/8	2024/7/7
	EMC102-KM-KM-3000	150929	2023/7/8	2024/7/7
RF Coaxial Cable HUBER+SUHNER	SUCOFLEX 104	Cable-CH4-03(250724)	2024/5/1	2025/4/30
	Sucoflex 104	MY 13380+295012/04	2024/5/1	2025/4/30
Signal & Spectrum Analyzer R&S	FSW43	101582	2024/4/12	2025/4/11
Software BV ADT	ADT_Radiated_ V7.6.15.9.5	N/A	N/A	N/A
Turn Table BV ADT	TT100	TT93021705	N/A	N/A
Turn Table Controller BV ADT	SC100	SC93021705	N/A	N/A

Notes:

1. The test was performed in HY - 966 chamber 3.
2. Tested Date: 2024/5/30

5 Limits of Test Items

5.1 RF Output Power

Device Category	Limit (Max Average Power)
Indoor access point	EIRP 36 dBm
Subordinate device	EIRP 36 dBm
Client device	EIRP 30 dBm

Note: For all U-NII-4 and U-NII-3 & -4 span channels shall met above EIRP values.

5.2 Power Spectral Density

Device Category	Limit
Indoor access point	EIRP 20 dBm/MHz
Subordinate device	EIRP 20 dBm/MHz
Client device	EIRP 14 dBm/MHz

Note: For all U-NII-4 and U-NII-3 & -4 span channels shall met above EIRP values.

5.3 6 dB Bandwidth

Within the 5.725-5.850 GHz and 5.850-5.895 GHz bands, the minimum 6 dB bandwidth of U-NII devices shall be at least 500 kHz.

5.4 Frequency Stability

The frequency of the carrier signal shall be maintained within band of operation.

5.5 AC Power Conducted Emissions

Frequency (MHz)	Conducted Limit (dBuV)	
	Quasi-peak	Average
0.15 - 0.5	66 - 56	56 - 46
0.50 - 5.0	56	46
5.0 - 30.0	60	50

Notes:

1. The lower limit shall apply at the transition frequencies.
2. The limit decreases in line with the logarithm of the frequency in the range of 0.15 to 0.50 MHz.

5.6 Unwanted Emissions below 1 GHz

Radiated emissions which fall in the restricted bands must comply with the radiated emission limits specified as below table.

Frequencies (MHz)	Field Strength (microvolts/meter)	Measurement Distance (meters)
0.009 ~ 0.490	2400/F(kHz)	300
0.490 ~ 1.705	24000/F(kHz)	30
1.705 ~ 30.0	30	30
30 ~ 88	100	3
88 ~ 216	150	3
216 ~ 960	200	3
Above 960	500	3

Notes:

1. The lower limit shall apply at the transition frequencies.
2. Emission level (dBuV/m) = 20 log Emission level (uV/m).

5.7 Unwanted Emissions above 1 GHz

- (i) For an indoor access point or subordinate device, all emissions at or above 5.895 GHz shall not exceed an e.i.r.p. of 15 dBm/MHz and shall decrease linearly to an e.i.r.p. of -7 dBm/MHz at or above 5.925 GHz.
- (ii) For a client device, all emissions at or above 5.895 GHz shall not exceed an e.i.r.p. of -5 dBm/MHz and shall decrease linearly to an e.i.r.p. of -27 dBm/MHz at or above 5.925 GHz.
- (iii) For a client device or indoor access point or subordinate device, all emissions below 5.725 GHz shall not exceed an e.i.r.p. of -27 dBm/MHz at 5.65 GHz increasing linearly to 10 dBm/MHz at 5.7 GHz, and from 5.7 GHz increasing linearly to a level of 15.6 dBm/MHz at 5.72 GHz, and from 5.72 GHz increasing linearly to a level of 27 dBm/MHz at 5.725 GHz.

Note:

The following formula is used to convert the equipment isotropic radiated power (eirp) to field strength:

$$E = \frac{1000000\sqrt{30P}}{3} \mu\text{V/m, where } P \text{ is the eirp (Watts).}$$

6 Test Arrangements

6.1 RF Output Power

6.1.1 Test Setup

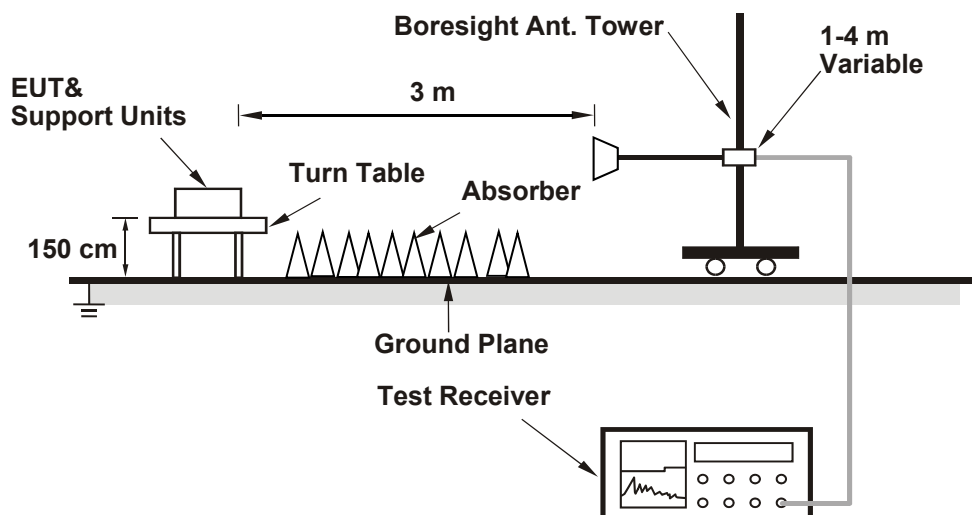

6.1.2 Test Procedure

- The EUT was placed on the top of a rotating table 1.5 meters above the ground at 3 meter chamber room for test. The table was rotated 360 degrees to determine the position of the highest radiation.
- The EUT was set 3 meters away from the interference-receiving antenna, which was mounted on the top of a variable-height antenna tower.
- The height of antenna is varied from one meter to four meters above the ground to determine the maximum value of the field strength. Both horizontal and vertical polarizations of the antenna are set to make the measurement.
- Perform a field strength measurement and record the worse read value, is the field strength value via a spectrum reading obtained corrected for antenna factor, cable loss and pre-amplifier factor and then mathematically convert the measured field strength level to EIRP level.
- Follow ANSI C63.10 section 12.7.3, $EIRP \text{ Value (dBm)} = \text{Field Strength Value (dBuV / m)} + \text{Correction Factor @ 3 m}$.
- $\text{Correction Factor (dB) @ 3 m} = 20\log(D) - 104.77 = -95.23 \text{ dB}$; where D is the measurement distance @3 m.

Spectrum analyzer setting as below:

Method SA-1

- Set span to encompass the entire emission bandwidth (EBW) of the signal.
- Set RBW = 1 MHz, Set VBW \geq 3 MHz, Detector = RMS
- Sweep points $\geq [2 \times \text{span} / \text{RBW}]$. (This gives bin-to-bin spacing $\leq \text{RBW} / 2$, so that narrowband signals are not lost between frequency bins.)
- Sweep time = auto, trigger set to "free run".
- Trace average at least 100 traces in power averaging mode.
- Record the max value

Note: When measuring power, use compute power by integrating the spectrum across the 26 dB EBW or 99% OBW of the signal using the instrument's band power measurement function, with band limits set equal to the EBW or OBW band edges. If the instrument does not have a band power function, then sum the spectrum levels (in power units) at 1 MHz intervals extending across the 26 dB EBW or 99% OBW of the spectrum.

6.2 Power Spectral Density

6.2.1 Test Setup

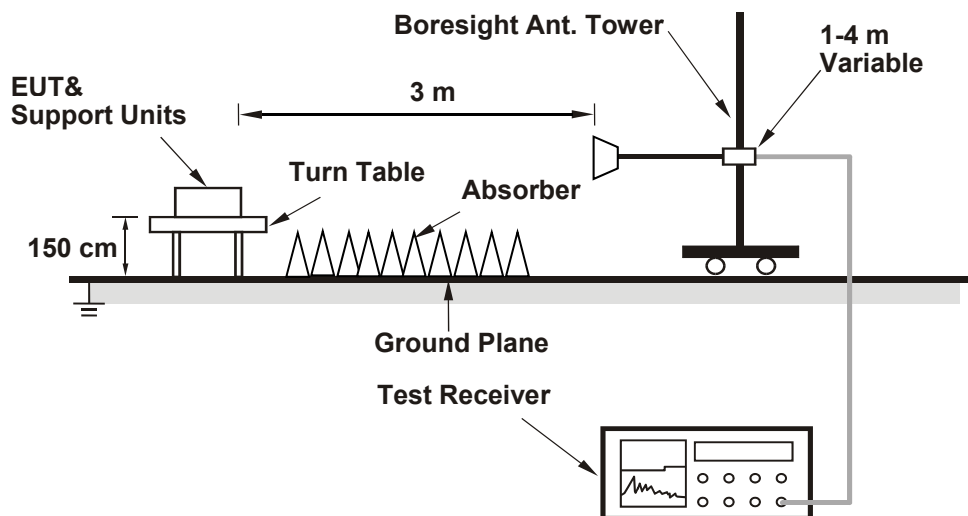

6.2.2 Test Procedure

- The EUT was placed on the top of a rotating table 1.5 meters above the ground at 3 meter chamber room for test. The table was rotated 360 degrees to determine the position of the highest radiation.
- The EUT was set 3 meters away from the interference-receiving antenna, which was mounted on the top of a variable-height antenna tower.
- The height of antenna is varied from one meter to four meters above the ground to determine the maximum value of the field strength. Both horizontal and vertical polarizations of the antenna are set to make the measurement.
- Perform a field strength measurement and record the worse read value, is the field strength value via a spectrum reading obtained corrected for antenna factor, cable loss and pre-amplifier factor and then mathematically convert the measured field strength level to EIRP level.
- Follow ANSI C63.10 section 12.7.3, $EIRP \text{ Value (dBm)} = \text{Field Strength Value (dBuV/m)} + \text{Correction Factor @ 3 m}$.
- $\text{Correction Factor (dB) @ 3 m} = 20\log(D) - 104.77$; where D is the measurement distance @3 m = -95.23 dB

Spectrum analyzer setting as below:

Method SA-1

- Set span to encompass the entire emission bandwidth (EBW) of the signal.
- Set RBW = 1 MHz, Set VBW \geq 3 MHz, Detector = RMS
- Sweep points $\geq [2 \times \text{span} / \text{RBW}]$. (This gives bin-to-bin spacing $\leq \text{RBW} / 2$, so that narrowband signals are not lost between frequency bins.)
- Sweep time = auto, trigger set to "free run".
- Trace average at least 100 traces in power averaging mode.
- Record the max value

6.3 6 dB Bandwidth

6.3.1 Test Setup

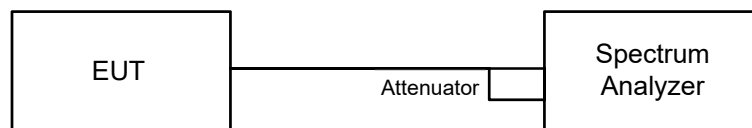

6.3.2 Test Procedure

- Set resolution bandwidth (RBW) = 100 kHz.
- Set the video bandwidth (VBW) $\geq 3 \times$ RBW, Detector = Peak.
- Trace mode = max hold.
- Sweep = auto couple.
- Measure the maximum width of the emission that is constrained by the frequencies associated with the two amplitude points (upper and lower) that are attenuated by 6 dB relative to the maximum level measured in the fundamental emission.

6.4 Frequency Stability

6.4.1 Test Setup

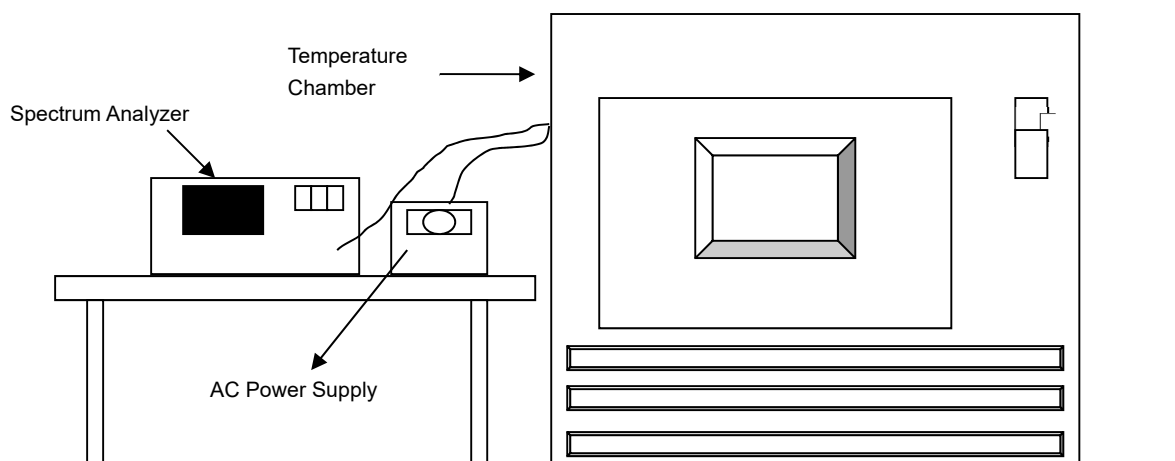

6.4.2 Test Procedure

- The EUT was placed inside the environmental test chamber and powered by nominal AC voltage.
- Turn the EUT on and couple its output to a spectrum analyzer.
- Turn the EUT off and set the chamber to the highest temperature specified.
- Allow sufficient time (approximately 30 min) for the temperature of the chamber to stabilize, turn the EUT on and measure the operating frequency after 2, 5, and 10 Minutes.
- Repeat step (d) with the temperature chamber set to the next desired temperature until measurements down to the lowest specified temperature have been completed.
- The test chamber was allowed to stabilize at +20 degree C for a minimum of 30 Minutes. The supply voltage was then adjusted on the EUT from 85% to 115% and the frequency record.

6.5 AC Power Conducted Emissions

6.5.1 Test Setup

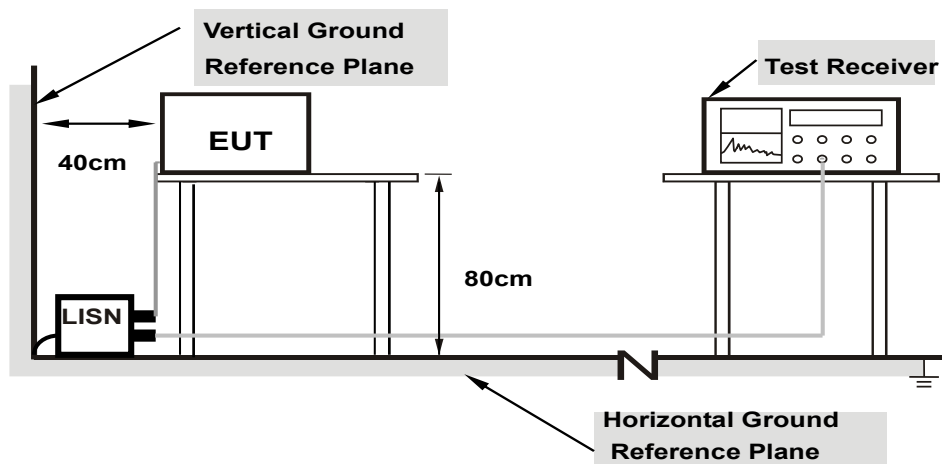

Note: 1. Support units were connected to second LISN.

For the actual test configuration, please refer to the attached file (Test Setup Photo).

6.5.2 Test Procedure

- The EUT was placed on a 0.8 meter to the top of table and placed 0.4 meters from the conducting wall of the shielded room with EUT being connected to the power mains through a line impedance stabilization network (LISN). Other support units were connected to the power mains through another LISN. The two LISNs provide 50 ohm/ 50 uH of coupling impedance for the measuring instrument.
- Both lines of the power mains connected to the EUT were checked for maximum conducted interference.
- The frequency range from 150 kHz to 30 MHz was searched. Emission levels under (Limit – 20 dB) was not recorded.

Note: The resolution bandwidth and video bandwidth of test receiver is 9 kHz for quasi-peak detection (QP) and average detection (AV) at frequency 0.15 MHz-30 MHz.

6.6 Unwanted Emissions below 1 GHz

6.6.1 Test Setup

For Radiated emission below 30 MHz

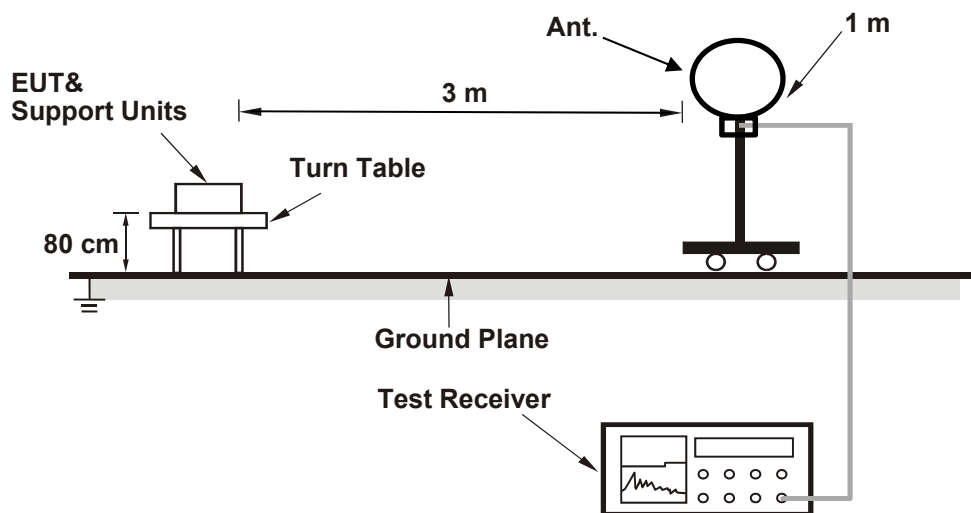

For Radiated emission above 30 MHz

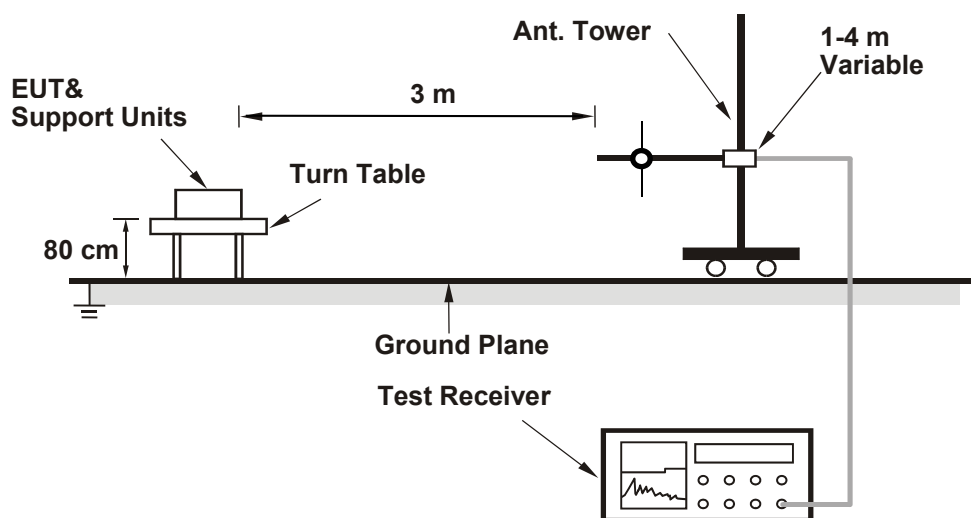

For the actual test configuration, please refer to the attached file (Test Setup Photo).

6.6.2 Test Procedure

For Radiated emission below 30 MHz

- a. The EUT was placed on the top of a rotating table 0.8 meters above the ground at 3 meter chamber room for test. The table was rotated 360 degrees to determine the position of the highest radiation.
- b. The EUT was set 3 meters away from the interference-receiving antenna, which was mounted on the top of a variable-height antenna tower.
- c. Parallel, perpendicular, and ground-parallel orientations of the antenna are set to make the measurement.
- d. For each suspected emission, the EUT was arranged to its worst case and the rotatable table was turned from 0 degrees to 360 degrees to find the maximum reading.
- e. The test-receiver system was set to Quasi-Peak Detect Function and Specified Bandwidth with Maximum Hold Mode, except for the frequency band (9 kHz to 90 kHz and 110 kHz to 490 kHz) set to average detect function and peak detect function.

Notes:

1. The resolution bandwidth and video bandwidth of test receiver/spectrum analyzer is 200 Hz at frequency below 150 kHz.
2. The resolution bandwidth and video bandwidth of test receiver/spectrum analyzer is 9 kHz or 10 kHz at frequency (150 kHz to 30 MHz).
3. All modes of operation were investigated and the worst-case emissions are reported.

For Radiated emission above 30 MHz

- a. The EUT was placed on the top of a rotating table 0.8 meters above the ground at 3 meter chamber room for test. The table was rotated 360 degrees to determine the position of the highest radiation.
- b. The EUT was set 3 meters away from the interference-receiving antenna, which was mounted on the top of a variable-height antenna tower.
- c. The height of antenna is varied from one meter to four meters above the ground to determine the maximum value of the field strength. Both horizontal and vertical polarizations of the antenna are set to make the measurement.
- d. For each suspected emission, the EUT was arranged to its worst case and then the antenna was tuned to heights from 1 meter to 4 meters and the rotatable table was turned from 0 degrees to 360 degrees to find the maximum reading.
- e. The test-receiver system was set to quasi-peak detect function and specified bandwidth with maximum hold mode when the test frequency is below 1 GHz.

Notes:

1. The resolution bandwidth and video bandwidth of test receiver/spectrum analyzer is 120 kHz for Quasi-peak detection (QP) at frequency below 1 GHz.
2. All modes of operation were investigated and the worst-case emissions are reported.

6.7 Unwanted Emissions above 1 GHz

6.7.1 Test Setup

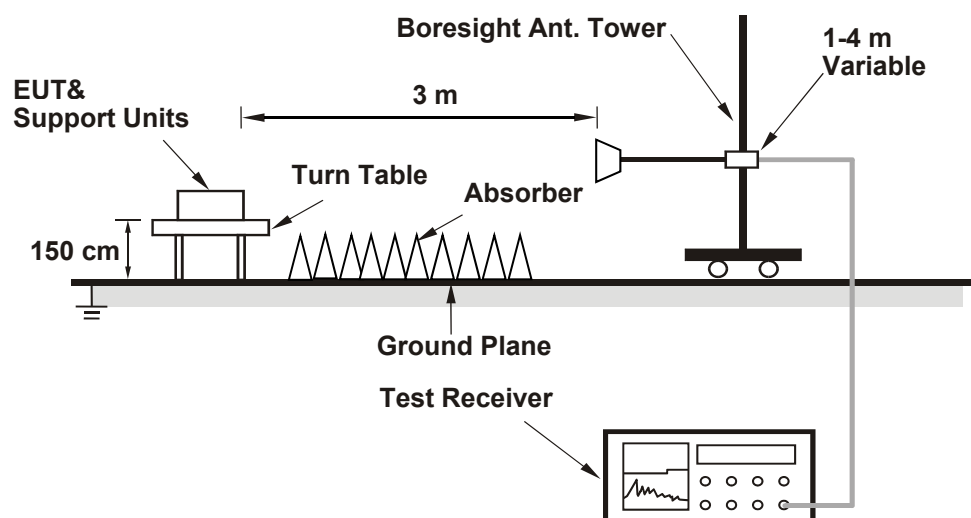

For the actual test configuration, please refer to the attached file (Test Setup Photo).

6.7.2 Test Procedure

- The EUT was placed on the top of a rotating table 1.5 meters above the ground at 3 meter chamber room for test. The table was rotated 360 degrees to determine the position of the highest radiation.
- The EUT was set 3 meters away from the interference-receiving antenna, which was mounted on the top of a variable-height antenna tower.
- The height of antenna is varied from one meter to four meters above the ground to determine the maximum value of the field strength. Both horizontal and vertical polarizations of the antenna are set to make the measurement.
- For each suspected emission, the EUT was arranged to its worst case and then the antenna was tuned to heights from 1 meter to 4 meters and the rotatable table was turned from 0 degrees to 360 degrees to find the maximum reading.
- The test-receiver system was set to peak and average detects function and specified bandwidth with maximum hold mode when the test frequency is above 1 GHz. If the peak reading value also meets average limit, measurement with the average detector is unnecessary.

Notes:

- The resolution bandwidth of test receiver/spectrum analyzer is 1 MHz and the video bandwidth is 3 MHz for Peak detection (PK) and Average detection (AV) at frequency above 1 GHz.
- For fundamental and harmonic signal measurement, the resolution bandwidth of test receiver/spectrum analyzer is 1 MHz and the video bandwidth is $\geq 1/T$ (Duty cycle $< 98\%$) or 10 Hz (Duty cycle $\geq 98\%$) for Average detection (AV) at frequency above 1 GHz.
- All modes of operation were investigated and the worst-case emissions are reported.

7 Test Results of Test Item

7.1 RF Output Power

Input Power:	120 Vac, 60 Hz	Environmental Conditions:	25°C, 60% RH	Tested By:	Jisyong Wang
--------------	----------------	---------------------------	--------------	------------	--------------

802.11a CDD

Chan.	Chan. Freq. (MHz)	Field Strength (dBuV/m)	Correction Factor (dB)	EIRP (mW)	EIRP (dBm)	EIRP Limit (dBm)	Test Result
169	5845	125.80	-95.23	1140.250	30.57	36	Pass
173	5865	125.40	-95.23	1039.920	30.17	36	Pass
177	5885	125.31	-95.23	1018.591	30.08	36	Pass

802.11be (EHT20) Beamforming

Chan.	Chan. Freq. (MHz)	Field Strength (dBuV/m)	Correction Factor (dB)	EIRP (mW)	EIRP (dBm)	EIRP Limit (dBm)	Test Result
169	5845	130.05	-95.23	3033.891	34.82	36	Pass
173	5865	129.57	-95.23	2716.439	34.34	36	Pass
177	5885	129.61	-95.23	2741.574	34.38	36	Pass

802.11be (EHT40) Beamforming

Chan.	Chan. Freq. (MHz)	Field Strength (dBuV/m)	Correction Factor (dB)	EIRP (mW)	EIRP (dBm)	EIRP Limit (dBm)	Test Result
167	5835	131.09	-95.23	3854.784	35.86	36	Pass
175	5875	130.89	-95.23	3681.290	35.66	36	Pass

802.11be (EHT80) Beamforming

Chan.	Chan. Freq. (MHz)	Field Strength (dBuV/m)	Correction Factor (dB)	EIRP (mW)	EIRP (dBm)	EIRP Limit (dBm)	Test Result
171	5855	130.91	-95.23	3698.282	35.68	36	Pass

802.11be (EHT160) Beamforming

Chan.	Chan. Freq. (MHz)	Field Strength (dBuV/m)	Correction Factor (dB)	EIRP (mW)	EIRP (dBm)	EIRP Limit (dBm)	Test Result
163	5815	127.46	-95.23	1671.091	32.23	36	Pass

Spectrum Plot of Maximum Value

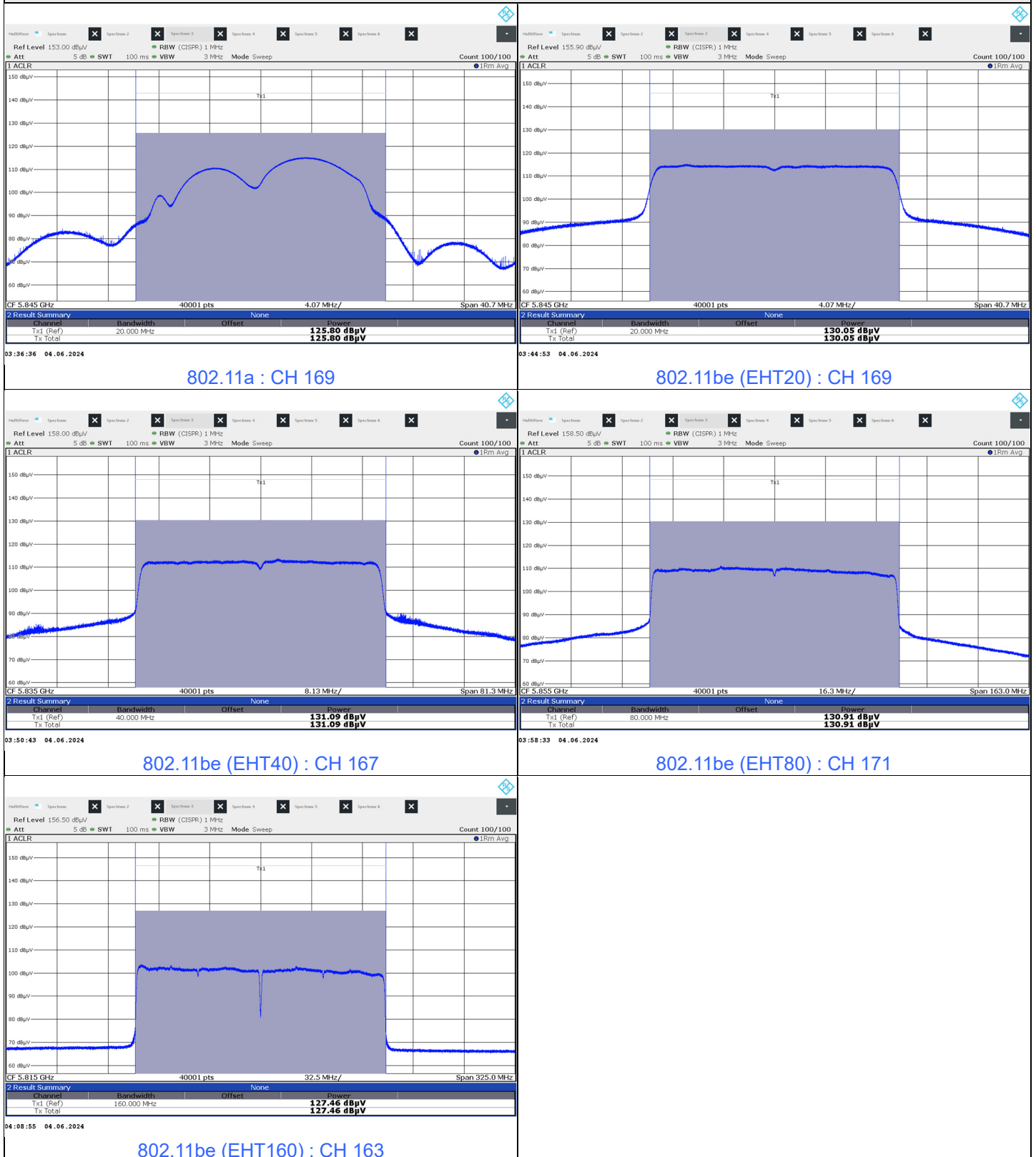

7.2 Power Spectral Density

Input Power:	120 Vac, 60 Hz	Environmental Conditions:	25°C, 60% RH	Tested By:	Jisyong Wang
--------------	----------------	---------------------------	--------------	------------	--------------

802.11a

Chan.	Chan. Freq. (MHz)	Field Strength (dBuV/m)	Correction Factor (dB)	EIRP PSD (dBm/MHz)	EIRP PSD Limit (dBm/MHz)	Test Result
169	5845	115.12	-95.23	19.89	20	Pass
173	5865	115.08	-95.23	19.85	20	Pass
177	5885	115.09	-95.23	19.86	20	Pass

802.11be (EHT20) Beamforming

Chan.	Chan. Freq. (MHz)	Field Strength (dBuV/m)	Correction Factor (dB)	EIRP PSD (dBm/MHz)	EIRP PSD Limit (dBm/MHz)	Test Result
169	5845	115.19	-95.23	19.96	20	Pass
173	5865	115.18	-95.23	19.95	20	Pass
177	5885	115.13	-95.23	19.90	20	Pass

802.11be (EHT40) Beamforming

Chan.	Chan. Freq. (MHz)	Field Strength (dBuV/m)	Correction Factor (dB)	EIRP PSD (dBm/MHz)	EIRP PSD Limit (dBm/MHz)	Test Result
167	5835	113.61	-95.23	18.38	20	Pass
175	5875	113.33	-95.23	18.10	20	Pass

802.11be (EHT80) Beamforming

Chan.	Chan. Freq. (MHz)	Field Strength (dBuV/m)	Correction Factor (dB)	EIRP PSD (dBm/MHz)	EIRP PSD Limit (dBm/MHz)	Test Result
171	5855	110.92	-95.23	15.69	20	Pass

802.11be (EHT160) Beamforming

Chan.	Chan. Freq. (MHz)	Field Strength (dBuV/m)	Correction Factor (dB)	EIRP PSD (dBm/MHz)	EIRP PSD Limit (dBm/MHz)	Test Result
163	5815	103.61	-95.23	8.38	20	Pass



Spectrum Plot of Maximum Value

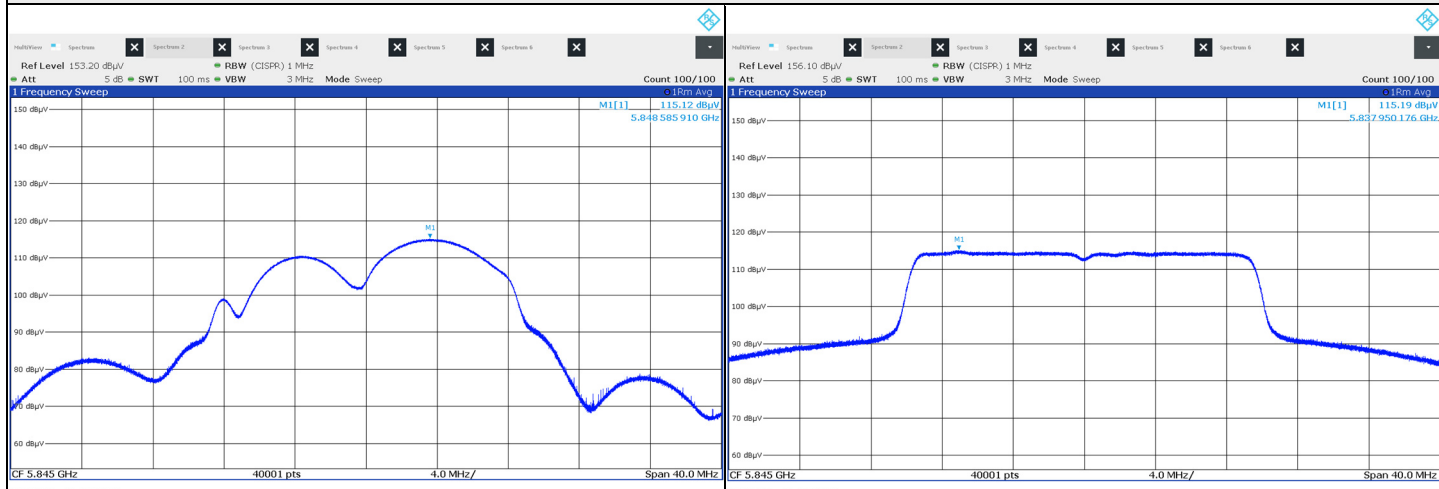

802.11be (EHT20) : CH 169

802.11be (EHT20) : CH 169

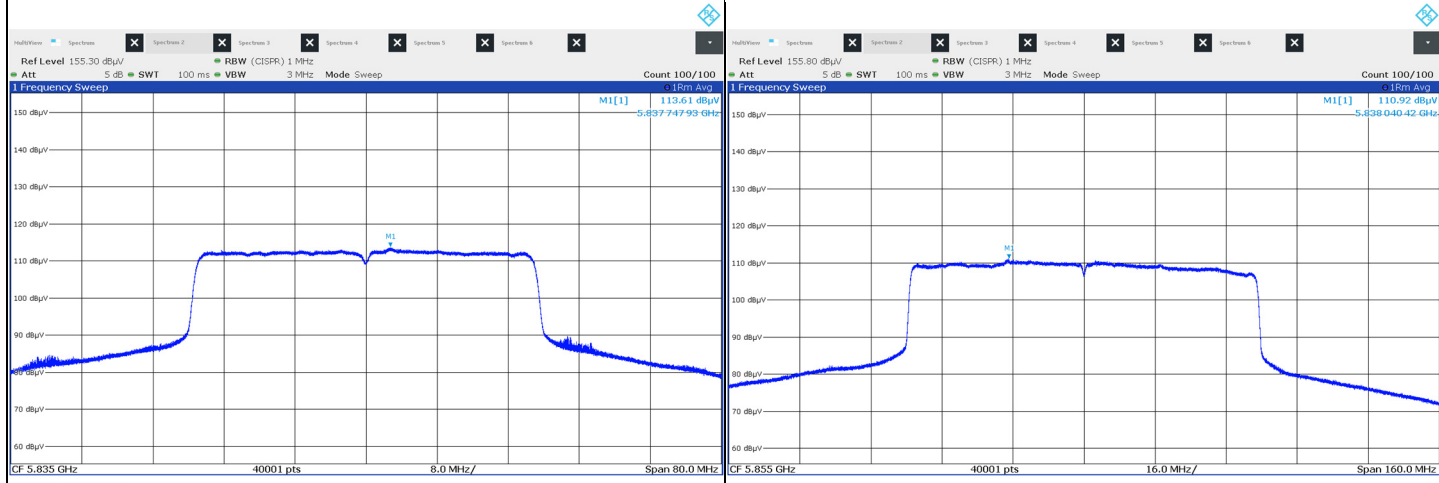

802.11be (EHT40) : CH 167

802.11be (EHT80) : CH 171

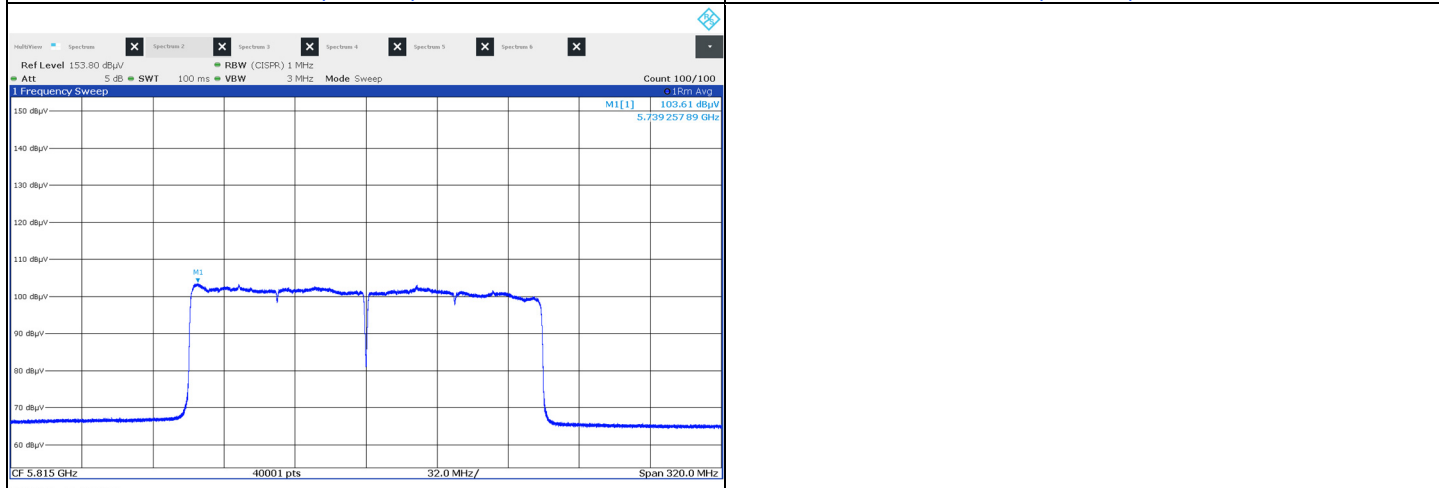

802.11be (EHT160) : CH 163

7.3 6 dB Bandwidth

Input Power:	120 Vac, 60 Hz	Environmental Conditions:	25°C, 60% RH	Tested By:	Jisyong Wang
--------------	----------------	---------------------------	--------------	------------	--------------

802.11a

Channel	Frequency (MHz)	6dB Bandwidth (MHz)				Minimum Limit (MHz)	Test Result
		Chain 0	Chain 1	Chain 2	Chain 3		
169	5845	16.41	16.41	16.40	16.42	0.5	Pass
173	5865	16.41	16.40	16.44	16.41	0.5	Pass
177	5885	16.40	16.38	16.42	16.40	0.5	Pass

802.11be (EHT20) Beamforming

Channel	Frequency (MHz)	6dB Bandwidth (MHz)				Minimum Limit (MHz)	Test Result
		Chain 0	Chain 1	Chain 2	Chain 3		
169	5845	19.06	18.97	19.05	19.00	0.5	Pass
173	5865	19.05	19.02	19.00	19.00	0.5	Pass
177	5885	19.05	18.92	18.99	19.04	0.5	Pass

802.11be (EHT40) Beamforming

Channel	Frequency (MHz)	6dB Bandwidth (MHz)				Minimum Limit (MHz)	Test Result
		Chain 0	Chain 1	Chain 2	Chain 3		
167	5835	38.06	37.90	37.89	38.00	0.5	Pass
175	5875	37.91	37.74	37.85	37.96	0.5	Pass

802.11be (EHT80) Beamforming

Channel	Frequency (MHz)	6dB Bandwidth (MHz)				Minimum Limit (MHz)	Test Result
		Chain 0	Chain 1	Chain 2	Chain 3		
171	5855	77.71	75.59	76.26	77.60	0.5	Pass

802.11be (EHT160) Beamforming

Channel	Frequency (MHz)	6dB Bandwidth (MHz)				Minimum Limit (MHz)	Test Result
		Chain 0	Chain 1	Chain 2	Chain 3		
163	5815	157.06	156.27	156.98	156.79	0.5	Pass

Spectrum Plot of Minimum Value

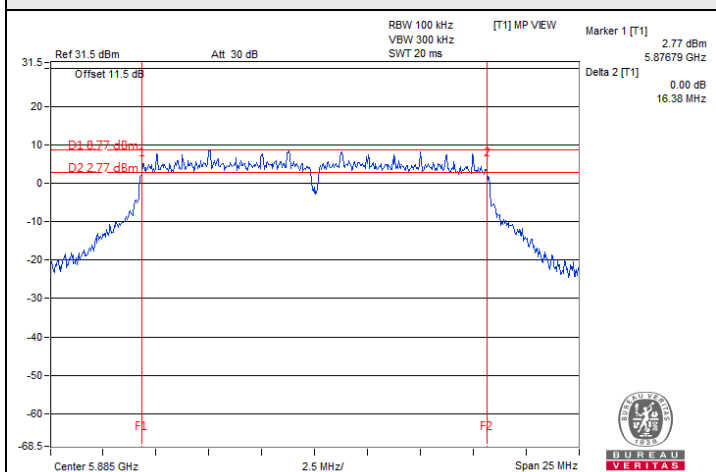

802.11a / Chain 1 : CH 177

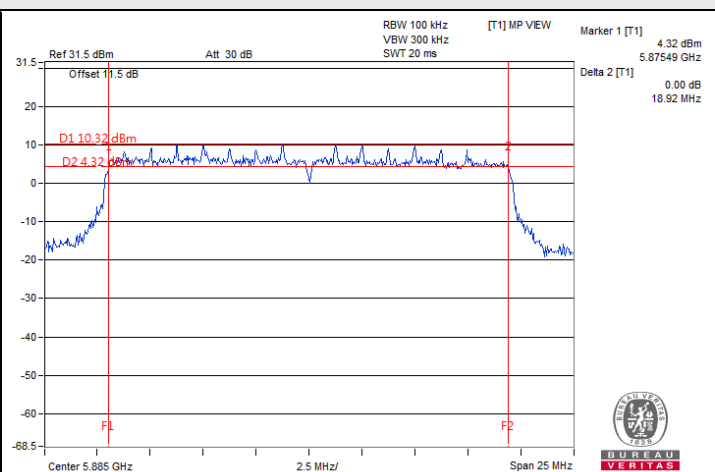

802.11be (EHT20) / Chain 1 : CH 177

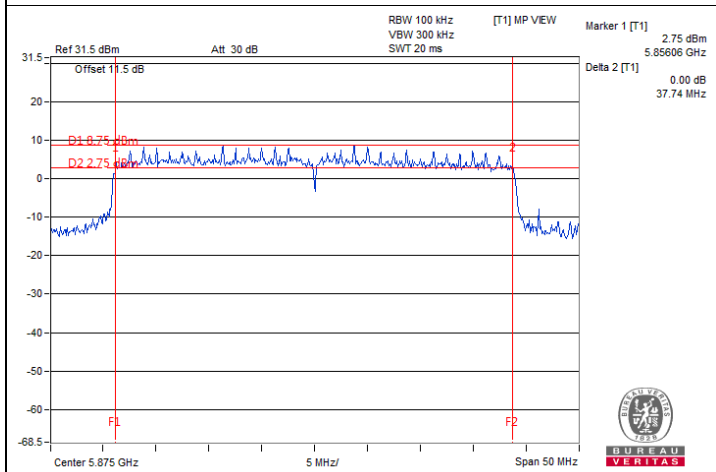

802.11be (EHT40) / Chain 1 : CH 175

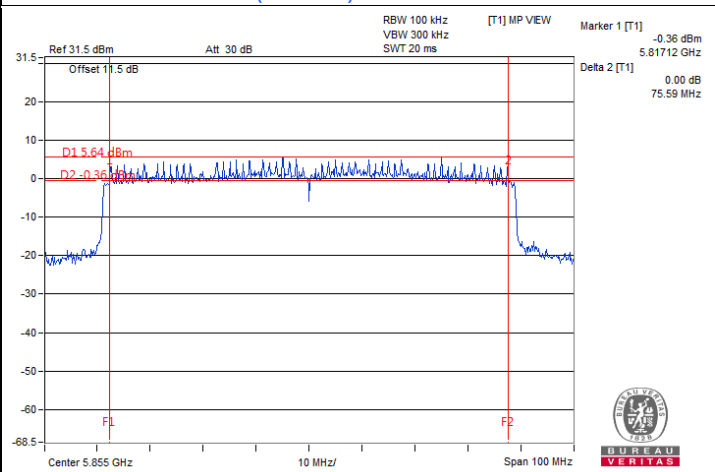

802.11be (EHT80) / Chain 1 : CH 171

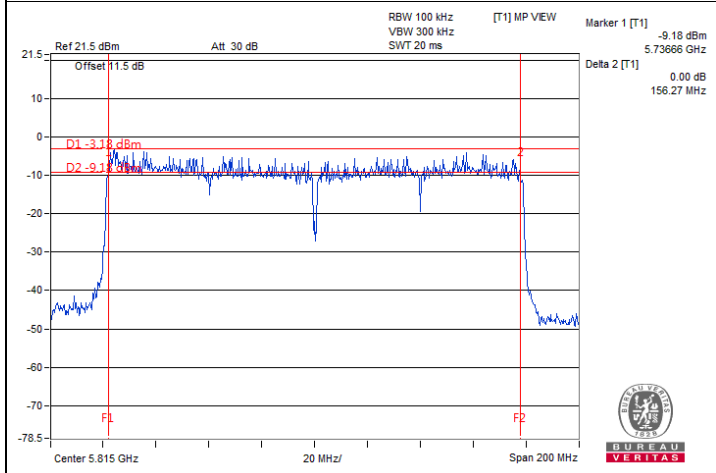

802.11be (EHT160) / Chain 1 : CH 163

7.4 Frequency Stability

Input Power:	120 Vac, 60 Hz	Environmental Conditions:	25°C, 60% RH	Tested By:	Jisyong Wang
--------------	----------------	---------------------------	--------------	------------	--------------

Frequency Stability Versus Temperature									
Operating Frequency: 5865 MHz									
Temp. (°C)	Power Supply (Vac)	0 Minute		2 Minutes		5 Minutes		10 Minutes	
		Measured Frequency (MHz)	Test Result	Measured Frequency (MHz)	Test Result	Measured Frequency (MHz)	Test Result	Measured Frequency (MHz)	Test Result
40	120	5865.0197	Pass	5865.0221	Pass	5865.0236	Pass	5865.0222	Pass
30	120	5864.9857	Pass	5864.9823	Pass	5864.9822	Pass	5864.9854	Pass
20	120	5864.992	Pass	5864.9904	Pass	5864.9908	Pass	5864.9937	Pass
10	120	5865.0007	Pass	5865	Pass	5865.0021	Pass	5865.0018	Pass
0	120	5864.991	Pass	5864.9879	Pass	5864.987	Pass	5864.9925	Pass

Frequency Stability Versus Voltage									
Operating Frequency: 5865 MHz									
Temp. (°C)	Power Supply (Vac)	0 Minute		2 Minutes		5 Minutes		10 Minutes	
		Measured Frequency (MHz)	Test Result	Measured Frequency (MHz)	Test Result	Measured Frequency (MHz)	Test Result	Measured Frequency (MHz)	Test Result
20	138	5864.9855	Pass	5864.9872	Pass	5864.9838	Pass	5864.9882	Pass
	120	5864.992	Pass	5864.9904	Pass	5864.9908	Pass	5864.9937	Pass
	102	5865.001	Pass	5865.0005	Pass	5865.0038	Pass	5865.004	Pass

7.5 AC Power Conducted Emissions

RF Mode	802.11be (EHT40)	Channel	CH 167 : 5835 MHz
Frequency Range	150 kHz ~ 30 MHz	Detector Function & Resolution Bandwidth	Quasi-Peak (QP) / Average (AV), 9 kHz
Input Power	120 Vac, 60 Hz	Environmental Conditions	23 °C, 67 % RH
Tested By	Adair Peng		

Phase Of Power : Line (L)										
No	Frequency (MHz)	Correction Factor (dB)	Reading Value (dBuV)		Emission Level (dBuV)		Limit (dBuV)		Margin (dB)	
			Q.P.	AV.	Q.P.	AV.	Q.P.	AV.	Q.P.	AV.
1	0.19000	9.72	33.14	23.15	42.86	32.87	64.04	54.04	-21.18	-21.17
2	0.24200	9.74	29.74	18.60	39.48	28.34	62.03	52.03	-22.55	-23.69
3	0.47800	9.84	23.45	14.50	33.29	24.34	56.37	46.37	-23.08	-22.03
4	1.47000	9.92	13.01	3.86	22.93	13.78	56.00	46.00	-33.07	-32.22
5	15.07400	10.27	5.65	2.05	15.92	12.32	60.00	50.00	-44.08	-37.68
6	26.94600	10.65	5.54	1.18	16.19	11.83	60.00	50.00	-43.81	-38.17

Remarks:

1. Q.P. and AV. are abbreviations of quasi-peak and average individually.
2. The emission levels of other frequencies were very low against the limit.
3. Margin value = Emission level – Limit value
4. Correction factor = Insertion loss + Cable loss
5. Emission Level = Correction Factor + Reading Value

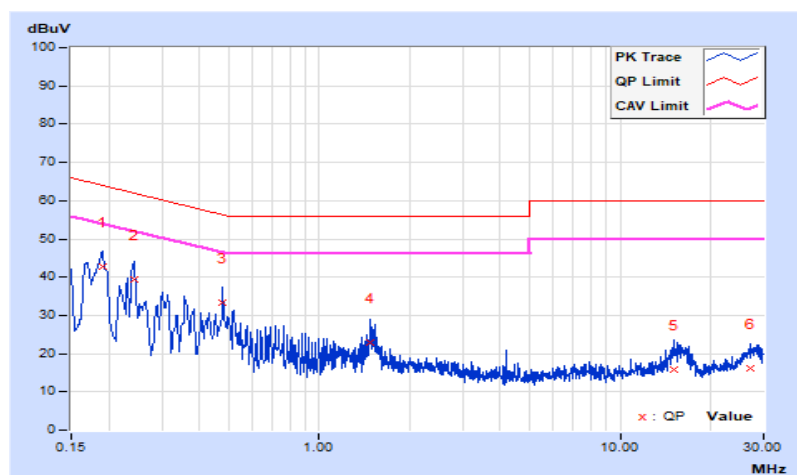

RF Mode	802.11be (EHT40)	Channel	CH 167 : 5835 MHz
Frequency Range	150 kHz ~ 30 MHz	Detector Function & Resolution Bandwidth	Quasi-Peak (QP) / Average (AV), 9 kHz
Input Power	120 Vac, 60 Hz	Environmental Conditions	23 °C, 67 % RH
Tested By	Adair Peng		

Phase Of Power : Neutral (N)										
No	Frequency (MHz)	Correction Factor (dB)	Reading Value (dBuV)		Emission Level (dBuV)		Limit (dBuV)		Margin (dB)	
			Q.P.	AV.	Q.P.	AV.	Q.P.	AV.	Q.P.	AV.
1	0.18037	9.70	35.12	26.13	44.82	35.83	64.47	54.47	-19.65	-18.64
2	0.24600	9.75	27.81	16.76	37.56	26.51	61.89	51.89	-24.33	-25.38
3	0.29000	9.78	23.80	13.38	33.58	23.16	60.52	50.52	-26.94	-27.36
4	0.48191	9.88	21.32	11.35	31.20	21.23	56.31	46.31	-25.11	-25.08
5	1.45400	9.95	11.77	3.77	21.72	13.72	56.00	46.00	-34.28	-32.28
6	4.57400	10.06	7.84	2.54	17.90	12.60	56.00	46.00	-38.10	-33.40

Remarks:

1. Q.P. and AV. are abbreviations of quasi-peak and average individually.
2. The emission levels of other frequencies were very low against the limit.
3. Margin value = Emission level – Limit value
4. Correction factor = Insertion loss + Cable loss
5. Emission Level = Correction Factor + Reading Value

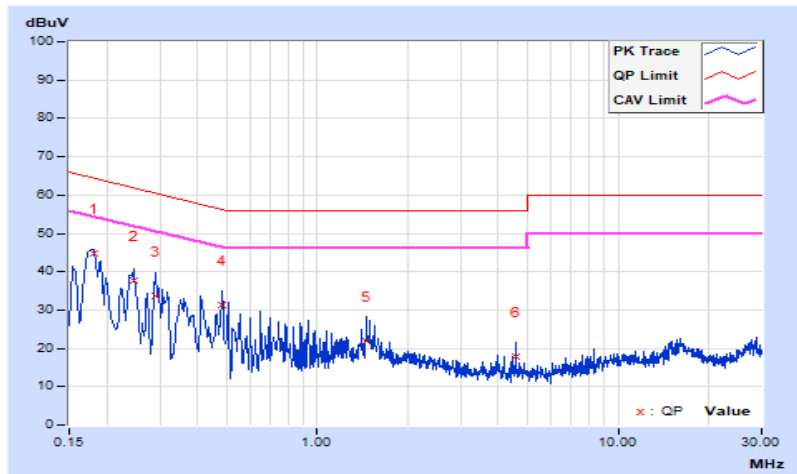

7.6 Unwanted Emissions below 1 GHz

RF Mode	802.11be (EHT40)	Channel	CH 167 : 5835 MHz
Frequency Range	30 MHz ~ 1 GHz	Detector Function & Bandwidth	QP: RB=120kHz, DET=Quasi-Peak
Input Power	120 Vac, 60 Hz	Environmental Conditions	23 °C, 66 % RH
Tested By	Luis Lee		

Antenna Polarity & Test Distance : Horizontal at 3 m								
No	Frequency (MHz)	Emission Level (dBuV/m)	Limit (dBuV/m)	Margin (dB)	Antenna Height (m)	Table Angle (Degree)	Raw Value (dBuV)	Correction Factor (dB/m)
1	35.82	27.5 QP	40.0	-12.5	1.00 H	247	37.4	-9.9
2	60.07	25.4 QP	40.0	-14.6	1.00 H	165	34.5	-9.1
3	140.58	29.9 QP	43.5	-13.6	1.00 H	247	39.1	-9.2
4	250.19	24.9 QP	46.0	-21.1	1.00 H	247	34.1	-9.2
5	435.46	27.0 QP	46.0	-19.0	1.50 H	329	31.9	-4.9
6	546.04	30.7 QP	46.0	-15.3	1.50 H	280	33.7	-3.0

Remarks:

1. Emission Level(dBuV/m) = Raw Value(dBuV) + Correction Factor(dB/m)
2. Correction Factor(dB/m) = Antenna Factor(dB/m) + Cable Factor(dB) – Pre-Amplifier Factor(dB)
3. Margin value = Emission Level – Limit value
4. The other emission levels were very low against the limit of frequency range 30 MHz ~ 1 GHz.
5. The frequency range 9 kHz ~ 30 MHz: all emissions are more than 20 dB below the limit, therefore do not be recorded in this report.

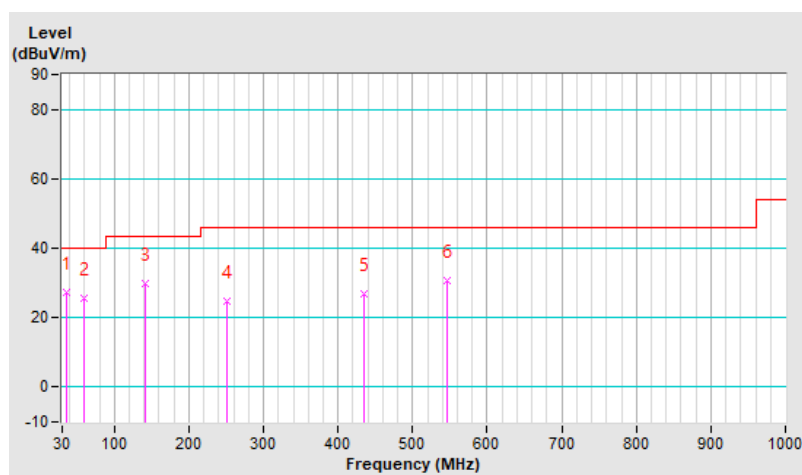

RF Mode	802.11be (EHT40)	Channel	CH 167 : 5835 MHz
Frequency Range	30 MHz ~ 1 GHz	Detector Function & Bandwidth	QP: RB=120kHz, DET=Quasi-Peak
Input Power	120 Vac, 60 Hz	Environmental Conditions	23 °C, 66 % RH
Tested By	Luis Lee		

Antenna Polarity & Test Distance : Vertical at 3 m								
No	Frequency (MHz)	Emission Level (dBuV/m)	Limit (dBuV/m)	Margin (dB)	Antenna Height (m)	Table Angle (Degree)	Raw Value (dBuV)	Correction Factor (dB/m)
1	60.07	36.2 QP	40.0	-3.8	1.00 V	297	45.3	-9.1
2	130.88	33.6 QP	43.5	-9.9	1.00 V	109	43.5	-9.9
3	302.57	22.8 QP	46.0	-23.2	1.50 V	140	30.2	-7.4
4	392.78	26.8 QP	46.0	-19.2	1.00 V	9	32.6	-5.8
5	545.07	32.2 QP	46.0	-13.8	1.00 V	341	35.3	-3.1
6	741.01	32.9 QP	46.0	-13.1	1.50 V	282	31.3	1.6

Remarks:

1. Emission Level(dBuV/m) = Raw Value(dBuV) + Correction Factor(dB/m)
2. Correction Factor(dB/m) = Antenna Factor(dB/m) + Cable Factor(dB) – Pre-Amplifier Factor(dB)
3. Margin value = Emission Level – Limit value
4. The other emission levels were very low against the limit of frequency range 30 MHz ~ 1 GHz.
5. The frequency range 9 kHz ~ 30 MHz: all emissions are more than 20 dB below the limit, therefore do not be recorded in this report.

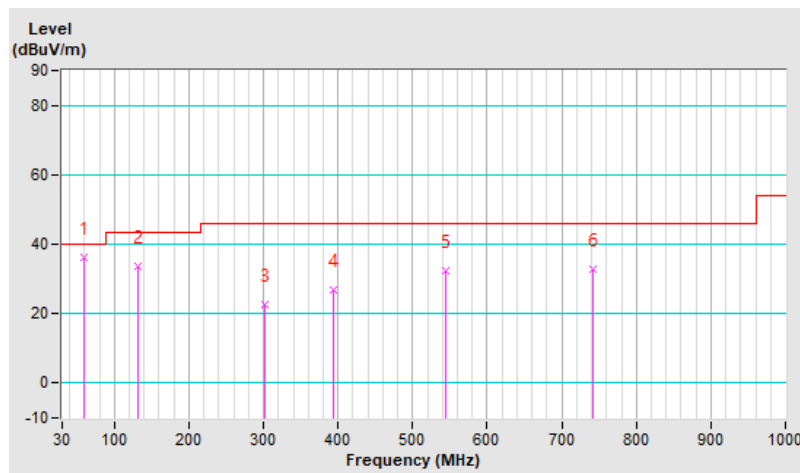

7.7 Unwanted Emissions above 1 GHz

RF Mode	802.11a	Channel	CH 169 : 5845 MHz
Frequency Range	1 GHz ~ 40 GHz	Detector Function & Bandwidth	PK: RB=1 MHz, VB=3 MHz, DET=Peak AV: RB=1 MHz, VB=10 Hz, DET=Peak
Input Power	120 Vac, 60 Hz	Environmental Conditions	23 °C, 66 % RH
Tested By	Luis Lee		

Antenna Polarity & Test Distance : Horizontal at 3 m								
No	Frequency (MHz)	Emission Level (dBuV/m)	Limit (dBuV/m)	Margin (dB)	Antenna Height (m)	Table Angle (Degree)	Raw Value (dBuV)	Correction Factor (dB/m)
1	#5650.00	61.0 PK	68.2	-7.2	1.40 H	126	47.6	13.4
2	*5845.00	118.8 PK			1.40 H	126	74.1	44.7
3	*5845.00	109.1 AV			1.40 H	126	64.4	44.7
4	#5895.00	68.2 PK	110.2	-42.0	1.40 H	126	54.3	13.9
5	11690.00	60.8 PK	74.0	-13.2	1.85 H	230	38.1	22.7
6	11690.00	49.6 AV	54.0	-4.4	1.85 H	230	26.9	22.7
Antenna Polarity & Test Distance : Vertical at 3 m								
No	Frequency (MHz)	Emission Level (dBuV/m)	Limit (dBuV/m)	Margin (dB)	Antenna Height (m)	Table Angle (Degree)	Raw Value (dBuV)	Correction Factor (dB/m)
1	#5650.00	61.9 PK	68.2	-6.3	2.09 V	117	48.5	13.4
2	*5845.00	124.4 PK			2.09 V	117	79.7	44.7
3	*5845.00	115.4 AV			2.09 V	117	70.7	44.7
4	#5895.00	73.6 PK	110.2	-36.6	2.09 V	117	59.7	13.9
5	11690.00	61.3 PK	74.0	-12.7	2.45 V	199	38.6	22.7
6	11690.00	50.1 AV	54.0	-3.9	2.45 V	199	27.4	22.7

Remarks:

1. Emission Level(dBuV/m) = Raw Value(dBuV) + Correction Factor(dB/m)
2. Correction Factor(dB/m) = Antenna Factor(dB/m) + Cable Factor(dB) – Pre-Amplifier Factor(dB)
3. Margin value = Emission Level – Limit value
4. The other emission levels were very low against the limit.
5. " * " : Fundamental frequency, the limit was restricted at the RF Output Power.
6. " # " : The radiated frequency is out of the restricted band.



RF Mode	802.11a	Channel	CH 173 : 5865 MHz
Frequency Range	1 GHz ~ 40 GHz	Detector Function & Bandwidth	PK: RB=1 MHz, VB=3 MHz, DET=Peak AV: RB=1 MHz, VB=10 Hz, DET=Peak
Input Power	120 Vac, 60 Hz	Environmental Conditions	23 °C, 66 % RH
Tested By	Luis Lee		

Antenna Polarity & Test Distance : Horizontal at 3 m

No	Frequency (MHz)	Emission Level (dBuV/m)	Limit (dBuV/m)	Margin (dB)	Antenna Height (m)	Table Angle (Degree)	Raw Value (dBuV)	Correction Factor (dB/m)
1	#5650.00	61.2 PK	68.2	-7.0	1.45 H	128	47.8	13.4
2	*5865.00	118.8 PK			1.45 H	128	74.0	44.8
3	*5865.00	109.1 AV			1.45 H	128	64.3	44.8
4	#5895.00	79.6 PK	110.2	-30.6	1.45 H	128	65.7	13.9
5	11730.00	60.4 PK	74.0	-13.6	1.88 H	227	38.0	22.4
6	11730.00	49.2 AV	54.0	-4.8	1.88 H	227	26.8	22.4

Antenna Polarity & Test Distance : Vertical at 3 m

No	Frequency (MHz)	Emission Level (dBuV/m)	Limit (dBuV/m)	Margin (dB)	Antenna Height (m)	Table Angle (Degree)	Raw Value (dBuV)	Correction Factor (dB/m)
1	#5650.00	62.0 PK	68.2	-6.2	1.93 V	118	48.6	13.4
2	*5865.00	124.8 PK			1.93 V	118	80.0	44.8
3	*5865.00	115.2 AV			1.93 V	118	70.4	44.8
4	#5895.00	87.8 PK	110.2	-22.4	1.93 V	118	73.9	13.9
5	11730.00	61.1 PK	74.0	-12.9	2.44 V	195	38.7	22.4
6	11730.00	49.9 AV	54.0	-4.1	2.44 V	195	27.5	22.4

Remarks:

1. Emission Level(dBuV/m) = Raw Value(dBuV) + Correction Factor(dB/m)
2. Correction Factor(dB/m) = Antenna Factor(dB/m) + Cable Factor(dB) – Pre-Amplifier Factor(dB)
3. Margin value = Emission Level – Limit value
4. The other emission levels were very low against the limit.
5. " * ": Fundamental frequency, the limit was restricted at the RF Output Power.
6. " # ": The radiated frequency is out of the restricted band.



RF Mode	802.11a	Channel	CH 177 : 5885 MHz
Frequency Range	1 GHz ~ 40 GHz	Detector Function & Bandwidth	PK: RB=1 MHz, VB=3 MHz, DET=Peak AV: RB=1 MHz, VB=10 Hz, DET=Peak
Input Power	120 Vac, 60 Hz	Environmental Conditions	23 °C, 66 % RH
Tested By	Luis Lee		

Antenna Polarity & Test Distance : Horizontal at 3 m								
No	Frequency (MHz)	Emission Level (dBuV/m)	Limit (dBuV/m)	Margin (dB)	Antenna Height (m)	Table Angle (Degree)	Raw Value (dBuV)	Correction Factor (dB/m)
1	#5650.00	61.2 PK	68.2	-7.0	1.41 H	123	47.8	13.4
2	*5885.00	117.5 PK			1.41 H	123	72.7	44.8
3	*5885.00	107.7 AV			1.41 H	123	62.9	44.8
4	#5898.00	99.9 PK	108.0	-8.1	1.41 H	123	86.0	13.9
5	#5925.00	73.8 PK	88.2	-14.4	1.41 H	123	59.9	13.9
6	11770.00	59.9 PK	74.0	-14.1	1.75 H	224	37.9	22.0
7	11770.00	48.8 AV	54.0	-5.2	1.75 H	224	26.8	22.0
Antenna Polarity & Test Distance : Vertical at 3 m								
No	Frequency (MHz)	Emission Level (dBuV/m)	Limit (dBuV/m)	Margin (dB)	Antenna Height (m)	Table Angle (Degree)	Raw Value (dBuV)	Correction Factor (dB/m)
1	#5650.00	62.0 PK	68.2	-6.2	2.19 V	129	48.6	13.4
2	*5885.00	123.7 PK			2.19 V	129	78.9	44.8
3	*5885.00	114.2 AV			2.19 V	129	69.4	44.8
4	#5899.00	105.4 PK	107.3	-1.9	2.19 V	129	91.5	13.9
5	#5925.00	79.1 PK	88.2	-9.1	2.19 V	129	65.2	13.9
6	11770.00	60.8 PK	74.0	-13.2	2.36 V	195	38.8	22.0
7	11770.00	49.6 AV	54.0	-4.4	2.36 V	195	27.6	22.0

Remarks:

1. Emission Level(dBuV/m) = Raw Value(dBuV) + Correction Factor(dB/m)
2. Correction Factor(dB/m) = Antenna Factor(dB/m) + Cable Factor(dB) – Pre-Amplifier Factor(dB)
3. Margin value = Emission Level – Limit value
4. The other emission levels were very low against the limit.
5. " * " : Fundamental frequency, the limit was restricted at the RF Output Power.
6. " # " : The radiated frequency is out of the restricted band.



RF Mode	802.11be (EHT20)	Channel	CH 169 : 5845 MHz
Frequency Range	1 GHz ~ 40 GHz	Detector Function & Bandwidth	PK: RB=1 MHz, VB=3 MHz, DET=Peak AV: RB=1 MHz, VB=10 Hz, DET=Peak
Input Power	120 Vac, 60 Hz	Environmental Conditions	23 °C, 66 % RH
Tested By	Luis Lee		

Antenna Polarity & Test Distance : Horizontal at 3 m

No	Frequency (MHz)	Emission Level (dBuV/m)	Limit (dBuV/m)	Margin (dB)	Antenna Height (m)	Table Angle (Degree)	Raw Value (dBuV)	Correction Factor (dB/m)
1	#5650.00	61.1 PK	68.2	-7.1	1.41 H	126	47.7	13.4
2	*5845.00	119.5 PK			1.41 H	126	74.8	44.7
3	*5845.00	107.5 AV			1.41 H	126	62.8	44.7
4	#5895.00	61.5 PK	110.2	-48.7	1.41 H	126	47.6	13.9
5	11690.00	60.6 PK	74.0	-13.4	1.79 H	215	37.9	22.7
6	11690.00	49.5 AV	54.0	-4.5	1.79 H	215	26.8	22.7

Antenna Polarity & Test Distance : Vertical at 3 m

No	Frequency (MHz)	Emission Level (dBuV/m)	Limit (dBuV/m)	Margin (dB)	Antenna Height (m)	Table Angle (Degree)	Raw Value (dBuV)	Correction Factor (dB/m)
1	#5650.00	61.9 PK	68.2	-6.3	2.08 V	118	48.5	13.4
2	*5845.00	126.2 PK			2.08 V	118	81.5	44.7
3	*5845.00	114.2 AV			2.08 V	118	69.5	44.7
4	#5895.00	62.4 PK	110.2	-47.8	2.08 V	118	48.5	13.9
5	11690.00	61.4 PK	74.0	-12.6	2.36 V	198	38.7	22.7
6	11690.00	50.3 AV	54.0	-3.7	2.36 V	198	27.6	22.7

Remarks:

1. Emission Level(dBuV/m) = Raw Value(dBuV) + Correction Factor(dB/m)
2. Correction Factor(dB/m) = Antenna Factor(dB/m) + Cable Factor(dB) – Pre-Amplifier Factor(dB)
3. Margin value = Emission Level – Limit value
4. The other emission levels were very low against the limit.
5. " * " : Fundamental frequency, the limit was restricted at the RF Output Power.
6. " # " : The radiated frequency is out of the restricted band.



RF Mode	802.11be (EHT20)	Channel	CH 173 : 5865 MHz
Frequency Range	1 GHz ~ 40 GHz	Detector Function & Bandwidth	PK: RB=1 MHz, VB=3 MHz, DET=Peak AV: RB=1 MHz, VB=10 Hz, DET=Peak
Input Power	120 Vac, 60 Hz	Environmental Conditions	23 °C, 66 % RH
Tested By	Luis Lee		

Antenna Polarity & Test Distance : Horizontal at 3 m

No	Frequency (MHz)	Emission Level (dBuV/m)	Limit (dBuV/m)	Margin (dB)	Antenna Height (m)	Table Angle (Degree)	Raw Value (dBuV)	Correction Factor (dB/m)
1	#5650.00	61.0 PK	68.2	-7.2	1.44 H	120	47.6	13.4
2	*5865.00	121.3 PK			1.44 H	120	76.5	44.8
3	*5865.00	109.3 AV			1.44 H	120	64.5	44.8
4	#5895.00	67.6 PK	110.2	-42.6	1.44 H	120	53.7	13.9
5	11730.00	60.2 PK	74.0	-13.8	1.80 H	213	37.8	22.4
6	11730.00	49.3 AV	54.0	-4.7	1.80 H	213	26.9	22.4

Antenna Polarity & Test Distance : Vertical at 3 m

No	Frequency (MHz)	Emission Level (dBuV/m)	Limit (dBuV/m)	Margin (dB)	Antenna Height (m)	Table Angle (Degree)	Raw Value (dBuV)	Correction Factor (dB/m)
1	#5650.00	62.2 PK	68.2	-6.0	2.24 V	122	48.8	13.4
2	*5865.00	127.7 PK			2.24 V	122	82.9	44.8
3	*5865.00	116.2 AV			2.24 V	122	71.4	44.8
4	#5895.00	75.2 PK	110.2	-35.0	2.24 V	122	61.3	13.9
5	11730.00	61.1 PK	74.0	-12.9	2.33 V	192	38.7	22.4
6	11730.00	49.8 AV	54.0	-4.2	2.33 V	192	27.4	22.4

Remarks:

1. Emission Level(dBuV/m) = Raw Value(dBuV) + Correction Factor(dB/m)
2. Correction Factor(dB/m) = Antenna Factor(dB/m) + Cable Factor(dB) – Pre-Amplifier Factor(dB)
3. Margin value = Emission Level – Limit value
4. The other emission levels were very low against the limit.
5. " * " : Fundamental frequency, the limit was restricted at the RF Output Power.
6. " # " : The radiated frequency is out of the restricted band.



RF Mode	802.11be (EHT20)	Channel	CH 177 : 5885 MHz
Frequency Range	1 GHz ~ 40 GHz	Detector Function & Bandwidth	PK: RB=1 MHz, VB=3 MHz, DET=Peak AV: RB=1 MHz, VB=10 Hz, DET=Peak
Input Power	120 Vac, 60 Hz	Environmental Conditions	23 °C, 66 % RH
Tested By	Luis Lee		

Antenna Polarity & Test Distance : Horizontal at 3 m

No	Frequency (MHz)	Emission Level (dBuV/m)	Limit (dBuV/m)	Margin (dB)	Antenna Height (m)	Table Angle (Degree)	Raw Value (dBuV)	Correction Factor (dB/m)
1	#5650.00	61.0 PK	68.2	-7.2	1.45 H	121	47.6	13.4
2	*5885.00	120.2 PK			1.45 H	121	75.4	44.8
3	*5885.00	107.9 AV			1.45 H	121	63.1	44.8
4	#5895.00	99.6 PK	110.2	-10.6	1.45 H	121	85.7	13.9
5	#5925.00	61.2 PK	88.2	-27.0	1.45 H	121	47.3	13.9
6	11770.00	59.9 PK	74.0	-14.1	1.77 H	212	37.9	22.0
7	11770.00	48.8 AV	54.0	-5.2	1.77 H	212	26.8	22.0

Antenna Polarity & Test Distance : Vertical at 3 m

No	Frequency (MHz)	Emission Level (dBuV/m)	Limit (dBuV/m)	Margin (dB)	Antenna Height (m)	Table Angle (Degree)	Raw Value (dBuV)	Correction Factor (dB/m)
1	#5650.00	62.2 PK	68.2	-6.0	1.81 V	143	48.8	13.4
2	*5885.00	126.5 PK			1.81 V	143	81.7	44.8
3	*5885.00	114.7 AV			1.81 V	143	69.9	44.8
4	#5895.00	106.4 PK	110.2	-3.8	1.81 V	143	92.5	13.9
5	#5925.00	65.1 PK	88.2	-23.1	1.81 V	143	51.2	13.9
6	11770.00	60.8 PK	74.0	-13.2	2.21 V	190	38.8	22.0
7	11770.00	49.5 AV	54.0	-4.5	2.21 V	190	27.5	22.0

Remarks:

1. Emission Level(dBuV/m) = Raw Value(dBuV) + Correction Factor(dB/m)
2. Correction Factor(dB/m) = Antenna Factor(dB/m) + Cable Factor(dB) – Pre-Amplifier Factor(dB)
3. Margin value = Emission Level – Limit value
4. The other emission levels were very low against the limit.
5. " * " : Fundamental frequency, the limit was restricted at the RF Output Power.
6. " # " : The radiated frequency is out of the restricted band.



RF Mode	802.11be (EHT40)	Channel	CH 167 : 5835 MHz
Frequency Range	1 GHz ~ 40 GHz	Detector Function & Bandwidth	PK: RB=1 MHz, VB=3 MHz, DET=Peak AV: RB=1 MHz, VB=10 Hz, DET=Peak
Input Power	120 Vac, 60 Hz	Environmental Conditions	23 °C, 66 % RH
Tested By	Luis Lee		

Antenna Polarity & Test Distance : Horizontal at 3 m

No	Frequency (MHz)	Emission Level (dBuV/m)	Limit (dBuV/m)	Margin (dB)	Antenna Height (m)	Table Angle (Degree)	Raw Value (dBuV)	Correction Factor (dB/m)
1	#5650.00	61.1 PK	68.2	-7.1	1.44 H	127	47.7	13.4
2	*5835.00	119.4 PK			1.44 H	127	74.7	44.7
3	*5835.00	106.9 AV			1.44 H	127	62.2	44.7
4	#5895.00	77.8 PK	110.2	-32.4	1.44 H	127	63.9	13.9
5	11670.00	60.3 PK	74.0	-13.7	1.75 H	221	37.6	22.7
6	11670.00	49.4 AV	54.0	-4.6	1.75 H	221	26.7	22.7

Antenna Polarity & Test Distance : Vertical at 3 m

No	Frequency (MHz)	Emission Level (dBuV/m)	Limit (dBuV/m)	Margin (dB)	Antenna Height (m)	Table Angle (Degree)	Raw Value (dBuV)	Correction Factor (dB/m)
1	#5650.00	62.1 PK	68.2	-6.1	2.08 V	145	48.7	13.4
2	*5835.00	126.2 PK			2.08 V	145	81.5	44.7
3	*5835.00	113.9 AV			2.08 V	145	69.2	44.7
4	#5895.00	83.9 PK	110.2	-26.3	2.08 V	145	70.0	13.9
5	11670.00	61.4 PK	74.0	-12.6	2.29 V	196	38.7	22.7
6	11670.00	50.1 AV	54.0	-3.9	2.29 V	196	27.4	22.7

Remarks:

1. Emission Level(dBuV/m) = Raw Value(dBuV) + Correction Factor(dB/m)
2. Correction Factor(dB/m) = Antenna Factor(dB/m) + Cable Factor(dB) – Pre-Amplifier Factor(dB)
3. Margin value = Emission Level – Limit value
4. The other emission levels were very low against the limit.
5. " * ": Fundamental frequency, the limit was restricted at the RF Output Power.
6. " # ": The radiated frequency is out of the restricted band.



RF Mode	802.11be (EHT40)	Channel	CH 175 : 5875 MHz
Frequency Range	1 GHz ~ 40 GHz	Detector Function & Bandwidth	PK: RB=1 MHz, VB=3 MHz, DET=Peak AV: RB=1 MHz, VB=10 Hz, DET=Peak
Input Power	120 Vac, 60 Hz	Environmental Conditions	23 °C, 66 % RH
Tested By	Luis Lee		

Antenna Polarity & Test Distance : Horizontal at 3 m

No	Frequency (MHz)	Emission Level (dBuV/m)	Limit (dBuV/m)	Margin (dB)	Antenna Height (m)	Table Angle (Degree)	Raw Value (dBuV)	Correction Factor (dB/m)
1	#5650.00	61.0 PK	68.2	-7.2	1.38 H	125	47.6	13.4
2	*5875.00	119.4 PK			1.38 H	125	74.6	44.8
3	*5875.00	107.7 AV			1.38 H	125	62.9	44.8
4	#5910.00	90.8 PK	99.2	-8.4	1.38 H	125	76.9	13.9
5	#5925.00	79.5 PK	88.2	-8.7	1.38 H	125	65.6	13.9
6	11750.00	59.7 PK	74.0	-14.3	1.72 H	230	37.6	22.1
7	11750.00	48.8 AV	54.0	-5.2	1.72 H	230	26.7	22.1

Antenna Polarity & Test Distance : Vertical at 3 m

No	Frequency (MHz)	Emission Level (dBuV/m)	Limit (dBuV/m)	Margin (dB)	Antenna Height (m)	Table Angle (Degree)	Raw Value (dBuV)	Correction Factor (dB/m)
1	#5650.00	62.0 PK	68.2	-6.2	2.59 V	131	48.6	13.4
2	*5875.00	125.7 PK			2.59 V	131	80.9	44.8
3	*5875.00	114.3 AV			2.59 V	131	69.5	44.8
4	#5895.00	97.1 PK	110.2	-13.1	2.59 V	131	83.2	13.9
5	#5925.00	84.4 PK	88.2	-3.8	2.59 V	131	70.5	13.9
6	11750.00	60.8 PK	74.0	-13.2	2.39 V	192	38.7	22.1
7	11750.00	49.5 AV	54.0	-4.5	2.39 V	192	27.4	22.1

Remarks:

1. Emission Level(dBuV/m) = Raw Value(dBuV) + Correction Factor(dB/m)
2. Correction Factor(dB/m) = Antenna Factor(dB/m) + Cable Factor(dB) – Pre-Amplifier Factor(dB)
3. Margin value = Emission Level – Limit value
4. The other emission levels were very low against the limit.
5. " * " : Fundamental frequency, the limit was restricted at the RF Output Power.
6. " # " : The radiated frequency is out of the restricted band.



RF Mode	802.11be (EHT80)	Channel	CH 171 : 5855 MHz
Frequency Range	1 GHz ~ 40 GHz	Detector Function & Bandwidth	PK: RB=1 MHz, VB=3 MHz, DET=Peak AV: RB=1 MHz, VB=10 Hz, DET=Peak
Input Power	120 Vac, 60 Hz	Environmental Conditions	23 °C, 66 % RH
Tested By	Luis Lee		

Antenna Polarity & Test Distance : Horizontal at 3 m

No	Frequency (MHz)	Emission Level (dBuV/m)	Limit (dBuV/m)	Margin (dB)	Antenna Height (m)	Table Angle (Degree)	Raw Value (dBuV)	Correction Factor (dB/m)
1	#5650.00	61.0 PK	68.2	-7.2	1.40 H	124	47.6	13.4
2	*5855.00	116.5 PK			1.40 H	124	71.8	44.7
3	*5855.00	105.2 AV			1.40 H	124	60.5	44.7
4	#5895.00	90.9 PK	110.2	-19.3	1.40 H	124	77.0	13.9
5	#5925.00	73.8 PK	88.2	-14.4	1.40 H	124	59.9	13.9
6	11710.00	60.3 PK	74.0	-13.7	1.88 H	214	37.8	22.5
7	11710.00	49.4 AV	54.0	-4.6	1.88 H	214	26.9	22.5

Antenna Polarity & Test Distance : Vertical at 3 m

No	Frequency (MHz)	Emission Level (dBuV/m)	Limit (dBuV/m)	Margin (dB)	Antenna Height (m)	Table Angle (Degree)	Raw Value (dBuV)	Correction Factor (dB/m)
1	#5650.00	62.2 PK	68.2	-6.0	2.00 V	142	48.8	13.4
2	*5855.00	123.7 PK			2.00 V	142	79.0	44.7
3	*5855.00	113.9 AV			2.00 V	142	69.2	44.7
4	#5895.00	95.3 PK	110.2	-14.9	2.00 V	142	81.4	13.9
5	#5925.00	80.3 PK	88.2	-7.9	2.00 V	142	66.4	13.9
6	11710.00	61.2 PK	74.0	-12.8	2.29 V	189	38.7	22.5
7	11710.00	50.1 AV	54.0	-3.9	2.29 V	189	27.6	22.5

Remarks:

1. Emission Level(dBuV/m) = Raw Value(dBuV) + Correction Factor(dB/m)
2. Correction Factor(dB/m) = Antenna Factor(dB/m) + Cable Factor(dB) – Pre-Amplifier Factor(dB)
3. Margin value = Emission Level – Limit value
4. The other emission levels were very low against the limit.
5. " * " : Fundamental frequency, the limit was restricted at the RF Output Power.
6. " # " : The radiated frequency is out of the restricted band.



RF Mode	802.11be (EHT160)	Channel	CH 163 : 5815 MHz
Frequency Range	1 GHz ~ 40 GHz	Detector Function & Bandwidth	PK: RB=1 MHz, VB=3 MHz, DET=Peak AV: RB=1 MHz, VB=10 Hz, DET=Peak
Input Power	120 Vac, 60 Hz	Environmental Conditions	23 °C, 66 % RH
Tested By	Luis Lee		

Antenna Polarity & Test Distance : Horizontal at 3 m

No	Frequency (MHz)	Emission Level (dBuV/m)	Limit (dBuV/m)	Margin (dB)	Antenna Height (m)	Table Angle (Degree)	Raw Value (dBuV)	Correction Factor (dB/m)
1	#5650.00	62.2 PK	68.2	-6.0	1.48 H	123	48.8	13.4
2	*5815.00	114.4 PK			1.48 H	123	69.6	44.8
3	*5815.00	104.1 AV			1.48 H	123	59.3	44.8
4	#5895.00	83.6 PK	110.2	-26.6	1.48 H	123	69.7	13.9
5	#5925.00	62.8 PK	88.2	-25.4	1.48 H	123	48.9	13.9
6	11630.00	60.4 PK	74.0	-13.6	1.80 H	223	37.6	22.8
7	11630.00	49.5 AV	54.0	-4.5	1.80 H	223	26.7	22.8

Antenna Polarity & Test Distance : Vertical at 3 m

No	Frequency (MHz)	Emission Level (dBuV/m)	Limit (dBuV/m)	Margin (dB)	Antenna Height (m)	Table Angle (Degree)	Raw Value (dBuV)	Correction Factor (dB/m)
1	#5650.00	67.7 PK	68.2	-0.5	2.01 V	144	54.3	13.4
2	*5815.00	120.0 PK			2.01 V	144	75.2	44.8
3	*5815.00	110.3 AV			2.01 V	144	65.5	44.8
4	#5895.00	90.3 PK	110.2	-19.9	2.01 V	144	76.4	13.9
5	#5925.00	69.2 PK	88.2	-19.0	2.01 V	144	55.3	13.9
6	11630.00	61.2 PK	74.0	-12.8	2.24 V	192	38.4	22.8
7	11630.00	50.1 AV	54.0	-3.9	2.24 V	192	27.3	22.8

Remarks:

1. Emission Level(dBuV/m) = Raw Value(dBuV) + Correction Factor(dB/m)
2. Correction Factor(dB/m) = Antenna Factor(dB/m) + Cable Factor(dB) – Pre-Amplifier Factor(dB)
3. Margin value = Emission Level – Limit value
4. The other emission levels were very low against the limit.
5. " * " : Fundamental frequency, the limit was restricted at the RF Output Power.
6. " # " : The radiated frequency is out of the restricted band.

Plot of Band Edge

Frequency Range	5.55 GHz ~ 6.025 GHz	Detector Function & Bandwidth	PK: RB=1 MHz, VB=3 MHz, DET=Peak
-----------------	----------------------	-------------------------------	----------------------------------

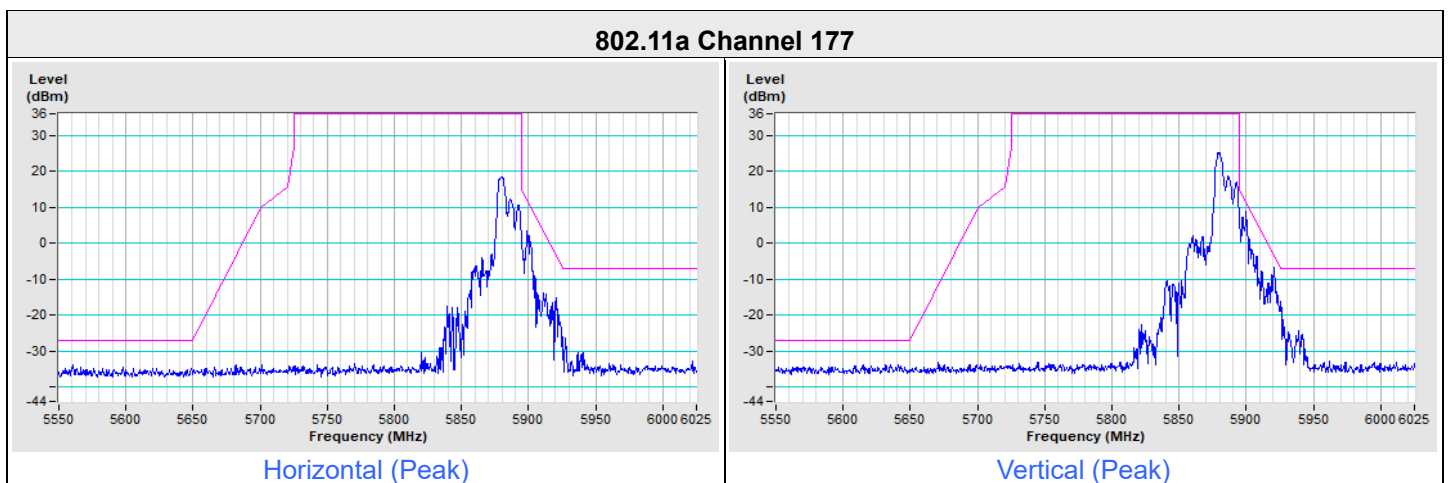
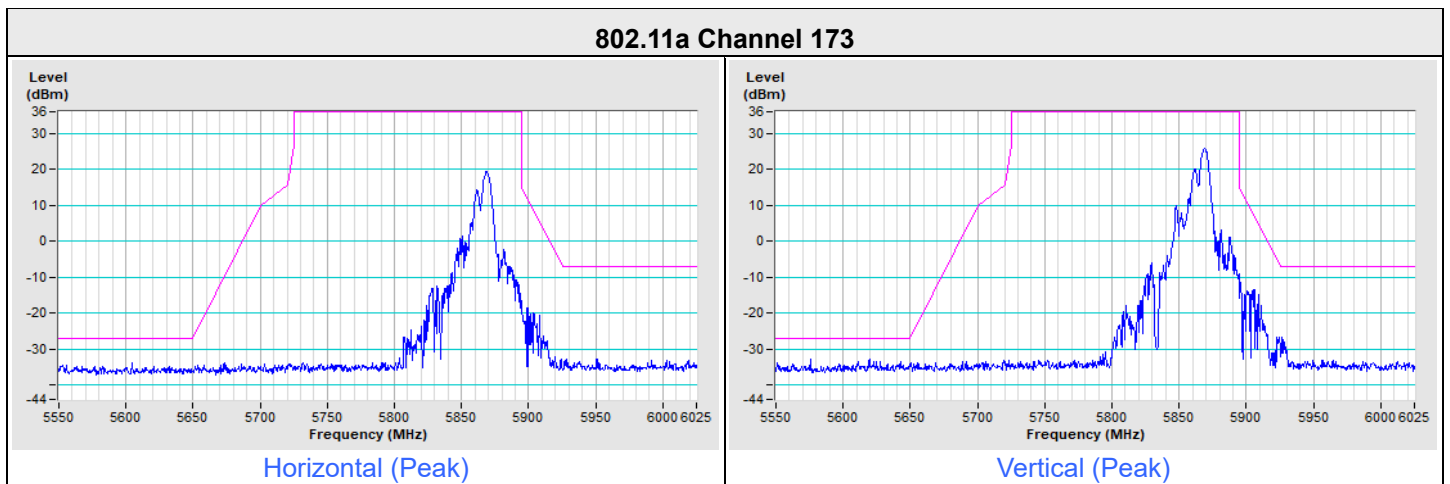
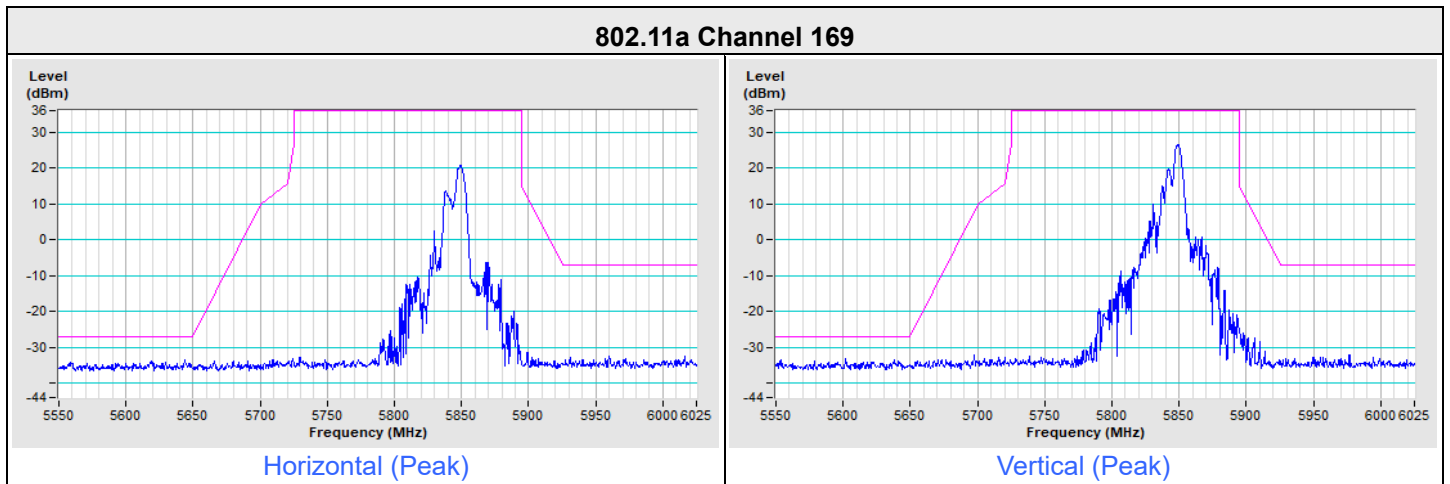



Frequency Range	5.55 GHz ~ 6.025 GHz	Detector Function & Bandwidth	PK: RB=1 MHz, VB=3 MHz, DET=Peak
-----------------	----------------------	-------------------------------	----------------------------------

802.11be (EHT20) Channel 169

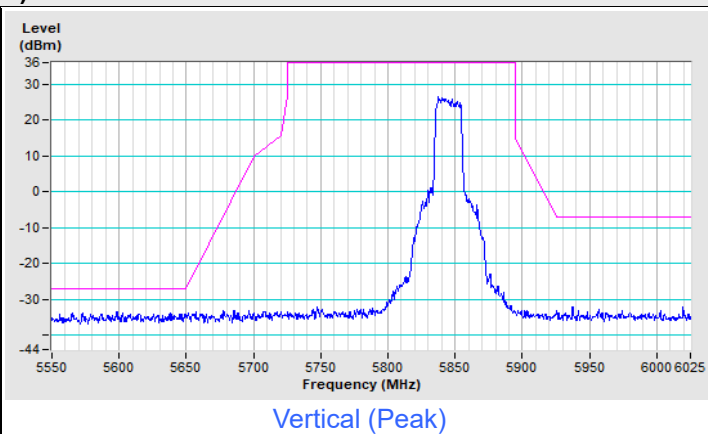
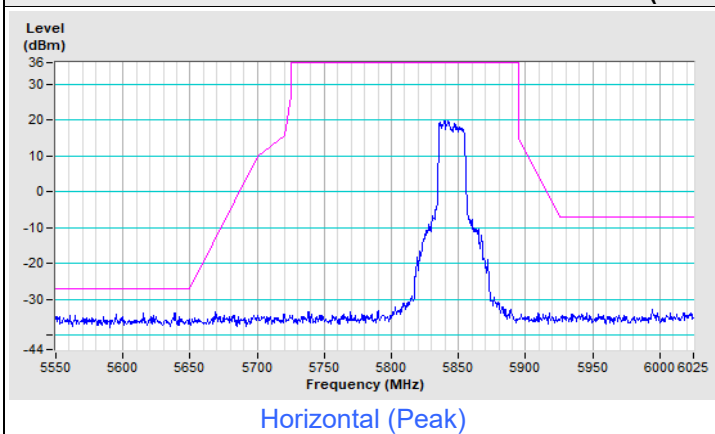

802.11be (EHT20) Channel 173

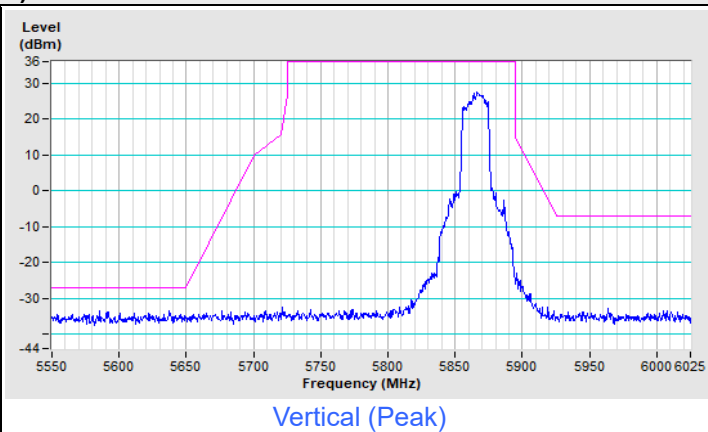
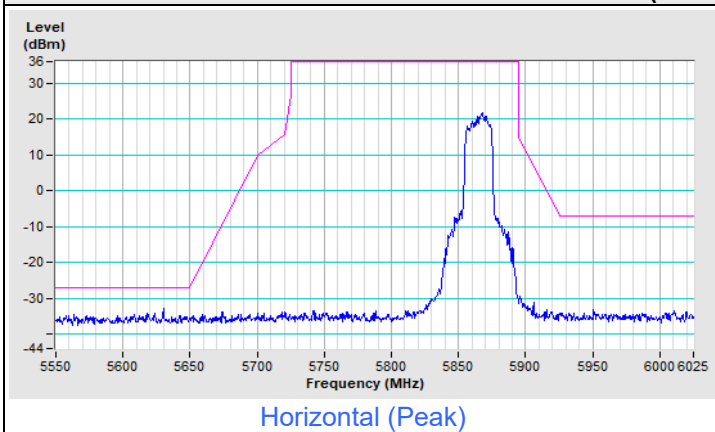

802.11be (EHT20) Channel 177

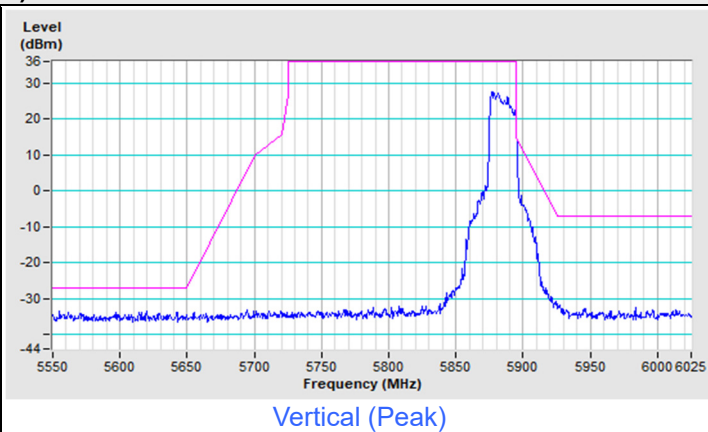
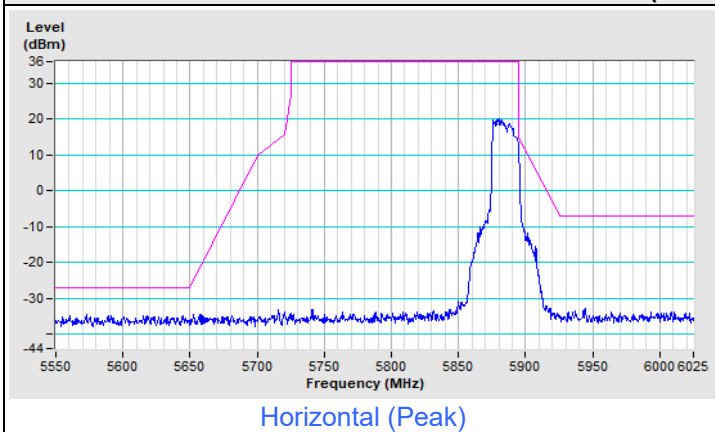



Frequency Range	5.55 GHz ~ 6.025 GHz	Detector Function & Bandwidth	PK: RB=1 MHz, VB=3 MHz, DET=Peak
-----------------	----------------------	-------------------------------	----------------------------------

802.11be (EHT40) Channel 167

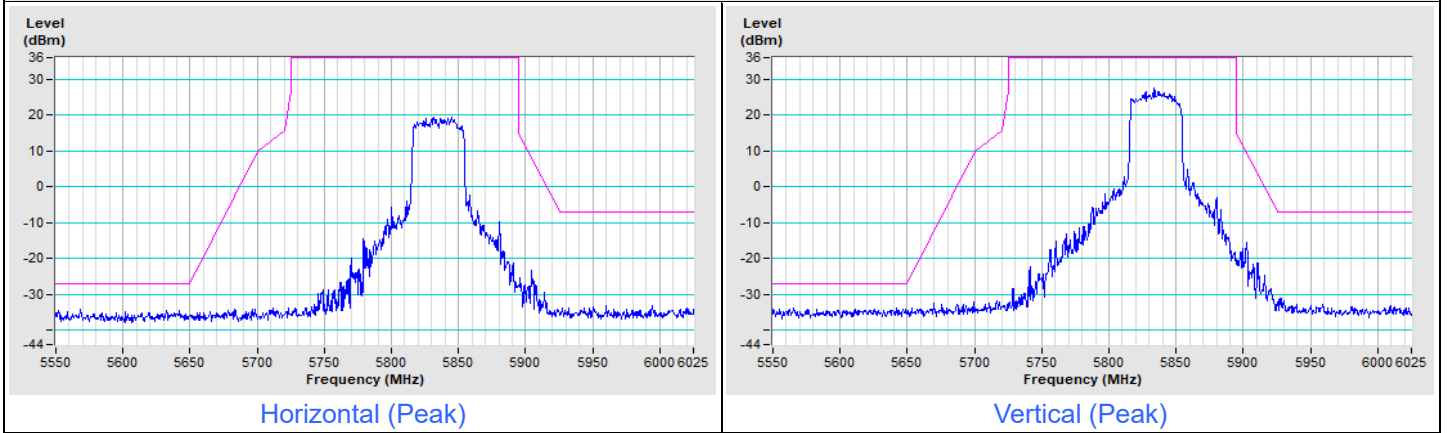

802.11be (EHT40) Channel 175

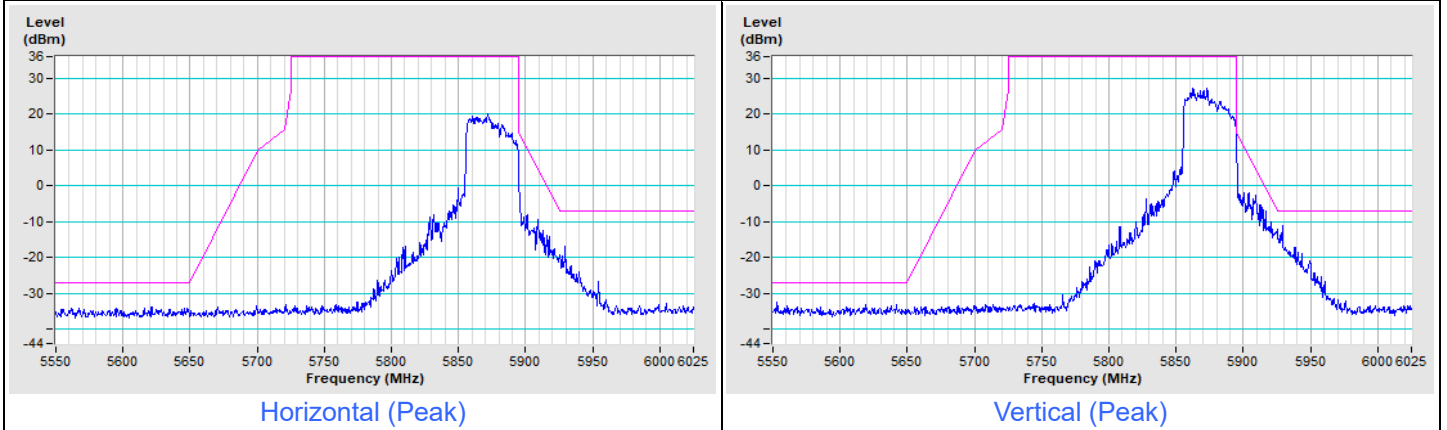

Frequency Range	5.55 GHz ~ 6.025 GHz	Detector Function & Bandwidth	PK: RB=1 MHz, VB=3 MHz, DET=Peak
-----------------	----------------------	-------------------------------	----------------------------------

802.11be (EHT80) Channel 171

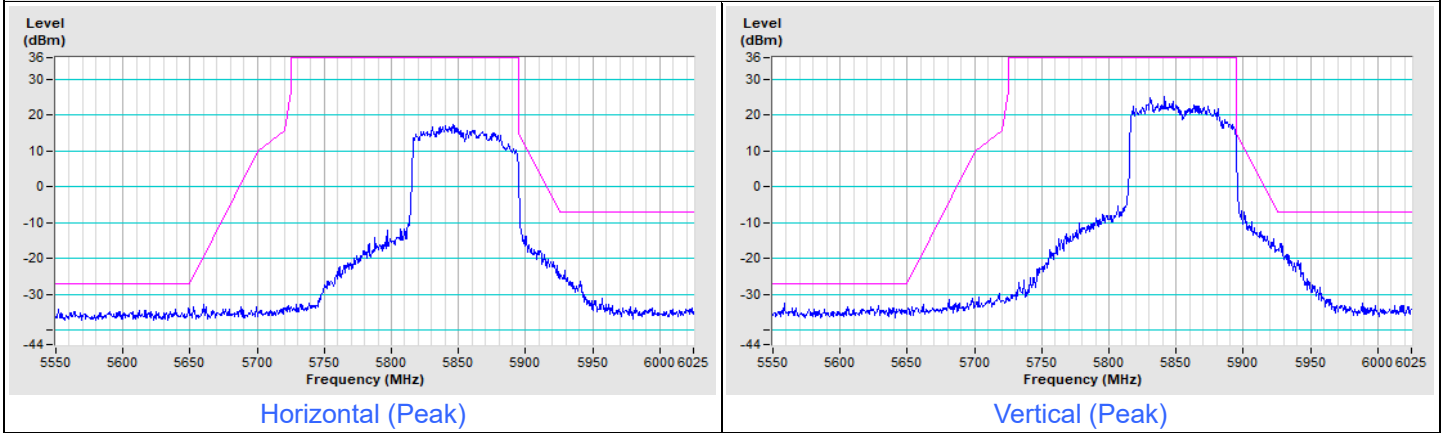

Frequency Range	5.55 GHz ~ 6.025 GHz	Detector Function & Bandwidth	PK: RB=1 MHz, VB=3 MHz, DET=Peak
-----------------	----------------------	-------------------------------	----------------------------------

802.11be (EHT160) Channel 163

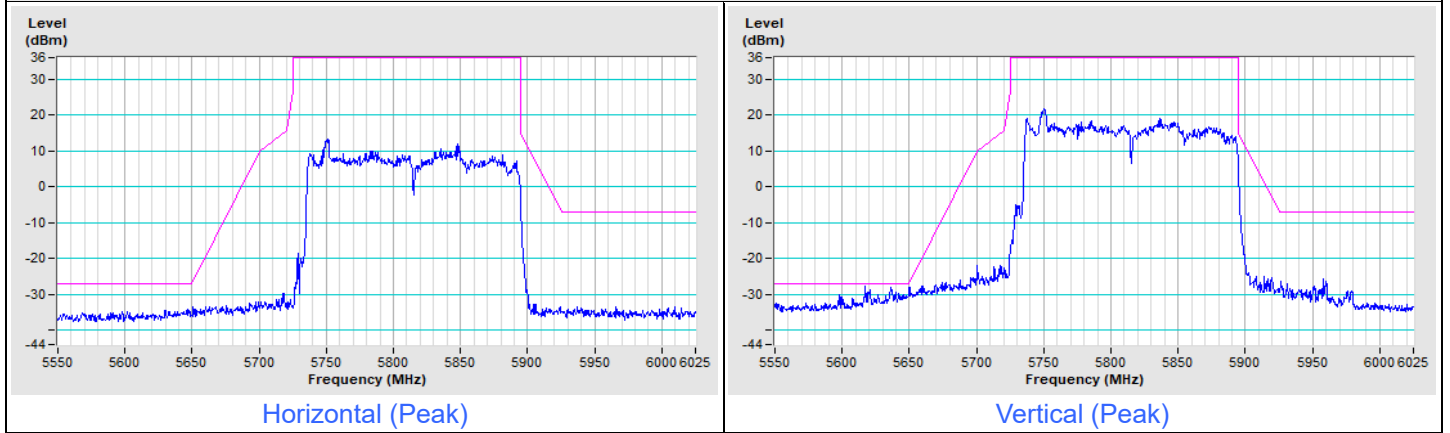

8 Pictures of Test Arrangements

Please refer to the attached file (Test Setup Photo)



9 Information of the Testing Laboratories

We, Bureau Veritas Consumer Products Services (H.K.) Ltd., Taoyuan Branch, were founded in 1988 to provide our best service in EMC, Radio, Telecom and Safety consultation. Our laboratories are FCC recognized accredited test firms and accredited according to ISO/IEC 17025.

If you have any comments, please feel free to contact us at the following:

Lin Kou EMC/RF Lab

Tel: 886-2-26052180

Fax: 886-2-26051924

Hsin Chu EMC/RF/Telecom Lab

Tel: 886-3-6668565

Fax: 886-3-6668323

Hwa Ya EMC/RF/Safety Lab

Tel: 886-3-3183232

Fax: 886-3-3270892

Email: service.adt@bureauveritas.com

Web Site: <http://ee.bureauveritas.com.tw>

The address and road map of all our labs can be found in our web site also.

--- END ---