

TEST REPORT

CERTIFICATE OF CONFORMITY

Standard: 47 CFR FCC Part 15, Subpart E (Section 15.407)

Report No.: RFBBQZ-WTW-P23070188-3

FCC ID: PY323200598

Product: Orbi WiFi 7 Router, Orbi WiFi 7 Satellite
(Refer to item 3.1 for the more details)

Brand: NETGEAR

Model No.: RBE771

Series Model: RBE770 (Refer to item 3.1 for the more details)

Received Date: 2023/7/11

Test Date: 2023/12/19 ~ 2024/2/19

Issued Date: 2024/3/22

Applicant and Manufacturer: NETGEAR, Inc.

Address: 350 East Plumeria Drive San Jose, CA 95134

Issued By: Bureau Veritas Consumer Products Services (H.K.) Ltd., Taoyuan Branch
Lin Kou Laboratories

Lab Address: No. 47-2, 14th Ling, Chia Pau Vil., Lin Kou Dist., New Taipei City, Taiwan

Test Location: No. 19, Hwa Ya 2nd Rd., Wen Hwa Vil., Kewi Shan Dist., Taoyuan City 33383, Taiwan

FCC Registration / 788550 / TW0003

Designation Number:

Approved by: Jeremy Lin, **Date:** 2024/3/22
Jeremy Lin / Project Engineer

This test report consists of 257 pages in total. It may be duplicated completely for legal use with the approval of the applicant. It should not be reproduced except in full, without the written approval of our laboratory. The test results in the report only apply to the tested sample. The test results in this report are traceable to the national or international standards.

Prepared by : Vera Huang / Specialist



This report is governed by, and incorporates by reference, the Conditions of Testing as posted at the date of issuance of this report at <http://www.bureauveritas.com/home/about-us/our-business/cps/about-us/terms-conditions/> and is intended for your exclusive use. Any copying or replication of this report to or for any other person or entity, or use of our name or trademark, is permitted only with our prior written permission. This report sets forth our findings solely with respect to the test samples identified herein. The results set forth in this report are not indicative or representative of the quality or characteristics of the lot from which a test sample was taken or any similar or identical product unless specifically and expressly noted. Our report includes all of the tests requested by you and the results thereof based upon the information that you provided to us. Measurement uncertainty is only provided upon request for accredited tests. Statements of conformity are based on simple acceptance criteria without taking measurement uncertainty into account, unless otherwise requested in writing. You have 60 days from date of issuance of this report to notify us of any material error or omission caused by our negligence or if you require measurement uncertainty; provided, however, that such notice shall be in writing and shall specifically address the issue you wish to raise. A failure to raise such issue within the prescribed time shall constitute your unqualified acceptance of the completeness of this report, the tests conducted and the correctness of the report contents.

Table of Contents

Release Control Record	4
1 Certificate.....	5
2 Summary of Test Results	6
2.1 Measurement Uncertainty	6
2.2 Supplementary Information	6
3 General Information	7
3.1 General Description of EUT	7
3.2 Antenna Description of EUT	10
3.3 Channel List.....	11
3.4 Test Mode Applicability and Tested Channel Detail.....	14
3.5 Duty Cycle of Test Signal.....	17
3.6 Test Program Used and Operation Descriptions	19
3.7 Connection Diagram of EUT and Peripheral Devices	19
3.8 Configuration of Peripheral Devices and Cable Connections	19
4 Test Instruments	20
4.1 Maximum RF Output Power	20
4.2 Maximum Power Spectral Density	20
4.3 Emission Bandwidth	20
4.4 In-Band Emission Mask.....	21
4.5 Occupied Bandwidth.....	21
4.6 Frequency Stability	21
4.7 Contention-based Protocol.....	21
4.8 AC Power Conducted Emissions	22
4.9 Unwanted Emissions below 1 GHz	23
4.10 Unwanted Emissions above 1 GHz.....	24
5 Limits of Test Items.....	25
5.1 Maximum RF Output Power	25
5.2 Maximum Power Spectral Density	25
5.3 Emission Bandwidth	25
5.4 In-Band Emission Mask.....	25
5.5 Occupied Bandwidth.....	25
5.6 Frequency Stability	25
5.7 Contention-based Protocol.....	26
5.8 AC Power Conducted Emissions	26
5.9 Unwanted Emissions below 1 GHz	26
5.10 Unwanted Emissions above 1 GHz.....	27
6 Test Arrangements.....	28
6.1 Maximum RF Output Power	28
6.1.1 Test Setup	28
6.1.2 Test Procedure.....	28
6.2 Maximum Power Spectral Density	29
6.2.1 Test Setup	29
6.2.2 Test Procedure.....	29
6.3 Emission Bandwidth	30
6.3.1 Test Setup	30
6.3.2 Test Procedure.....	30
6.4 In-Band Emission Mask.....	30
6.4.1 Test Setup	30
6.4.2 Test Procedure.....	30
6.5 Occupied Bandwidth.....	31
6.5.1 Test Setup	31
6.5.2 Test Procedure.....	31
6.6 Frequency Stability	31
6.6.1 Test Setup	31



6.6.2	Test Procedure	31
6.7	Contention-based Protocol	32
6.7.1	Test Setup	32
6.7.2	Test Procedure	32
6.8	AC Power Conducted Emissions	33
6.8.1	Test Setup	33
6.8.2	Test Procedure	33
6.9	Unwanted Emissions below 1 GHz	34
6.9.1	Test Setup	34
6.9.2	Test Procedure	35
6.10	Unwanted Emissions above 1 GHz	36
6.10.1	Test Setup	36
6.10.2	Test Procedure	36
7	Test Results of Test Item	37
7.1	Maximum RF Output Power	37
7.2	Maximum Power Spectral Density	44
7.3	Emission Bandwidth	51
7.4	In-Band Emission Mask	58
7.5	Occupied Bandwidth	97
7.6	Frequency Stability	104
7.7	Contention-based Protocol	105
7.8	AC Power Conducted Emissions	123
7.9	Unwanted Emissions below 1 GHz	127
7.10	Unwanted Emissions above 1 GHz	131
8	Pictures of Test Arrangements	256
9	Information of the Testing Laboratories	257



Release Control Record

Issue No.	Description	Date Issued
RFBBQZ-WTW-P23070188-3	Original Release	2024/3/22

1 Certificate

Product: Orbi WiFi 7 Router, Orbi WiFi 7 Satellite
(Refer to item 3.1 for the more details)

Brand: NETGEAR

Test Model: RBE771

Series Model: RBE770 (Refer to item 3.1 for the more details)

Sample Status: Engineering Sample

Applicant and Manufacturer: NETGEAR, Inc.

Test Date: 2023/12/19 ~ 2024/2/19

Standard: 47 CFR FCC Part 15, Subpart E (Section 15.407)

Measurement procedure: ANSI C63.10-2013

KDB 987594 D02 U-NII 6 GHz EMC Measurement v02r01

KDB 789033 D02 General UNII Test Procedure New Rules v02r01

KDB 662911 D01 Multiple Transmitter Output v02r01

The above equipment has been tested by **Bureau Veritas Consumer Products Services (H.K.) Ltd., Taoyuan Branch**, and found compliance with the requirement of the above standards. The test record, data evaluation & Equipment Under Test (EUT) configurations represented herein are true and accurate accounts of the measurements of the sample's RF characteristics under the conditions specified in this report.

2 Summary of Test Results

47 CFR FCC Part 15, Subpart E (Section 15.407)			
Clause	Test Item	Result	Remark
15.407(a)(5) 15.407(a)(6)	Maximum RF Output Power	Pass	Meet the requirement of limit.
15.407(a)(5) 15.407(a)(6)	Maximum Power Spectral Density	Pass	Meet the requirement of limit.
15.407(a)(10)	Emission Bandwidth	Pass	Meet the requirement of limit.
15.407(a)(10)	Occupied Bandwidth	Pass	Meet the requirement of limit.
15.407(b)(9)	AC Power Conducted Emissions	Pass	Minimum passing margin is -15.14 dB at 0.25000 MHz
15.407(b)(9)	Unwanted Emissions below 1 GHz	Pass	Minimum passing margin is -5.6 dB at 51.09 MHz
15.407(b)(6) 15.407(b)(10)	Unwanted Emissions above 1 GHz	Pass	Minimum passing margin is -0.1 dB at 7125.00 and 7250.00 MHz
15.407(b)(7)	In-Band Emission Mask	Pass	Meet the requirement of limit.
15.407(d)(6)	Contention-based Protocol	Pass	Meet the requirement of limit.
15.407(g)	Frequency Stability	Pass	Meet the requirement of limit.
15.203	Antenna Requirement	Pass	Antenna connector is ipex(MHF) not a standard connector.

Notes:

1. Determining compliance based on the results of the compliance measurement, not taking into account measurement instrumentation uncertainty.
2. Per TCBC notice, FCC allows 99% BW measurements for Wi-Fi 320MHz BW mode instead of Emission Bandwidth.

2.1 Measurement Uncertainty

Where relevant, the following measurement uncertainty levels have been estimated for tests performed on the EUT as specified in CISPR 16-4-2:

Parameter	Specification	Uncertainty (±)
Maximum RF Output Power	1 GHz ~ 18 GHz	2.29 dB
Maximum Power Spectral Density	1 GHz ~ 18 GHz	2.29 dB
Occupied Bandwidth	-	72 Hz
AC Power Conducted Emissions	9 kHz ~ 30 MHz	2.88 dB
Unwanted Emissions below 1 GHz	9 kHz ~ 30 MHz	3.59 dB
	30 MHz ~ 1 GHz	3.64 dB
Unwanted Emissions above 1 GHz	1 GHz ~ 18 GHz	2.29 dB
	18 GHz ~ 40 GHz	2.29 dB

The other instruments specified are routine verified to remain within the calibrated levels, no measurement uncertainty is required to be calculated.

2.2 Supplementary Information

There is not any deviation from the test standards for the test method, and no modifications required for compliance.

3 General Information

3.1 General Description of EUT

Product	Orbi WiFi 7 Router, Orbi WiFi 7 Satellite
Brand	NETGEAR
Test Model	RBE771
Series Model	RBE770
Model Difference	Refer to Note
Status of EUT	Engineering Sample
Power Supply Rating	Refer to Note as below
Modulation Type	64QAM, 16QAM, QPSK, BPSK for OFDM 1024QAM for OFDMA in 11ax mode 4096QAM for OFDMA in 11be mode
Modulation Technology	OFDM, OFDMA
Transfer Rate	802.11a: up to 54 Mbps 802.11ax: up to 2401.9 Mbps 802.11be: up to 5764 Mbps
Operating Frequency	6.115 GHz ~ 6.415 GHz 6.425 GHz ~ 6.525 GHz 6.535 GHz ~ 6.865 GHz 6.875 GHz ~ 7.115 GHz
Number of Channel	802.11a, 802.11ax (HE20), 802.11be (EHT20): 51 802.11ax (HE40), 802.11be (EHT40): 25 802.11ax (HE80), 802.11be (EHT80): 12 802.11ax (HE160), 802.11be (EHT160): 6 802.11be (EHT320): 5
Output Power	CDD Mode: 6.115 GHz ~ 6.415 GHz : EIRP: 38.194 mW (15.82 dBm) 6.425 GHz ~ 6.525 GHz : EIRP: 37.497 mW (15.74 dBm) 6.535 GHz ~ 6.865 GHz : EIRP: 36.898 mW (15.67 dBm) 6.875 GHz ~ 7.115 GHz : EIRP: 38.019 mW (15.80 dBm) Beamforming (2T1S) Mode: 6.115 GHz ~ 6.415 GHz : EIRP: 843.335 mW (29.26 dBm) 6.425 GHz ~ 6.525 GHz : EIRP: 816.582 mW (29.12 dBm) 6.535 GHz ~ 6.865 GHz : EIRP: 845.279 mW (29.27 dBm) 6.875 GHz ~ 7.115 GHz : EIRP: 859.014 mW (29.34 dBm) Beamforming (2T2S) Mode: 6.115 GHz ~ 6.415 GHz : EIRP: 946.237 mW (29.76 dBm) 6.425 GHz ~ 6.525 GHz : EIRP: 986.279 mW (29.94 dBm) 6.535 GHz ~ 6.865 GHz : EIRP: 944.061 mW (29.75 dBm) 6.875 GHz ~ 7.115 GHz : EIRP: 926.83 mW (29.67 dBm)
Equipment Class	6ID: 15E 6 GHz Low-power indoor access point and 6PP: 15E 6 GHz Subordinate indoor device.

Note:

1. All models are listed as below.

Brand	Product	Model	Difference
NETGEAR	Orbi WiFi 7 Router	RBE771	Four 2.5G Ethernet ports (1 WAN + 3 LAN)
	Orbi WiFi 7 Satellite	RBE770	Two 2.5G Ethernet ports (2 LAN)

2. The EUT uses following accessories.

AC Adapter 1	Brand	NETGEAR
	Model	ADS-40FPC-12 12030E
	Part Number	332-11700-01
	AC Input	100-240V, ~50/60Mhz Max. 1.0A
	DC Output	12V, 2.5A
	DC Output Cable	1.8m non-shielded and without core
	Plug	US/EU/AU
	Color	White
AC Adapter 2	Brand	NETGEAR
	Model	2AED030FC
	Part Number	332-11713-01
	AC Input	100-240V, ~50/60Mhz Max. 1.0A
	DC Output	12V, 2.5A 30W
	DC Output Cable	1.8m non-shielded and without core
	Plug	US/EU/AU
	Color	White
AC Adapter 3	Brand	NETGEAR
	Model	AD2150F10
	Part Number	332-11093-02
	AC Input	100-120V, ~50/60Mhz Max. 1.0A
	DC Output	12V, 3.5A
	DC Output Cable	1.8m non-shielded and without core
	Plug	US
	Color	White
AC Adapter 4	Brand	NETGEAR
	Model	AD2150M20
	Part Number	332-11099-06
	AC Input	100-240V, ~50/60Mhz Max. 1.0A
	DC Output	12V, 3.5A 42W
	DC Output Cable	1.8m non-shielded and without core
	Plug	US
	Color	White
AC Adapter 5	Brand	NETGEAR
	Model	AD2150M20
	Part Number	332-11099-05
	AC Input	100-240V, ~50/60Mhz Max. 1.0A
	DC Output	12V, 3.5A 42W
	DC Output Cable	1.8m non-shielded and without core
	Plug	US, EU, AU
	Color	White

AC Adapter 6	Brand	NETGEAR
	Model	ADS-40FPC-12 12030E
	Part Number	332-11699-01
	AC Input	100-240V, ~50/60Mhz Max. 1.0A
	DC Output	12V, 2.5A
	DC Output Cable	1.8m non-shielded and without core
	Plug	US, EU
	Color	Black
AC Adapter 7	Brand	NETGEAR
	Model	2AED030FC
	Part Number	332-11712-01
	AC Input	100-240V, ~50/60Mhz Max. 1.0A
	DC Output	12V, 2.5A 30W
	DC Output Cable	1.8m non-shielded and without core
	Plug	US, EU
	Color	Black
Ethernet Cable	Brand	NETGEAR
	Model	312-10133-01
	Signal Line	2m, Unshielded

* After pretesting, Adapter 1 was the worst case and chosen for final test.

* The design of Adapter 1 and Adapter 6 are identical. The difference between them is Exterior color.

* The design of Adapter 2 and Adapter 7 are identical. The difference between them is Exterior color.

* The design of Adapter 4 and Adapter 5 are identical. The difference between them are Adapter 4 is adding more safety logos on the rating label.

3. The above EUT information is declared by manufacturer and for more detailed features description, please refer to the manufacturer's specifications or user's manual.

3.2 Antenna Description of EUT

1. The antenna information is listed as below.

Antenna Type	Connector Type	Frequency Range	Antenna Gain (dBi)	
			Chain 0	Chain 1
Dipole	ipex(MHF)	5925~6425 MHz	3.22	3.40
Dipole	ipex(MHF)	6425~6525 MHz	4.08	4.25
Dipole	ipex(MHF)	6525~6875 MHz	4.65	4.62
Dipole	ipex(MHF)	6875~7125 MHz	4.24	4.05

* Detail antenna specification please refer to antenna datasheet and/or antenna measurement report.

2. The EUT incorporates a MIMO function:

6 GHz Band			
Modulation Mode	Beamforming Mode	Tx & Rx Configuration	
802.11a	Not Support	2TX	2RX
802.11ax (HE20)	Support	2TX (Nss 1 / Nss 2)	2RX
802.11ax (HE40)	Support	2TX (Nss 1 / Nss 2)	2RX
802.11ax (HE80)	Support	2TX (Nss 1 / Nss 2)	2RX
802.11ax (HE160)	Support	2TX (Nss 1 / Nss 2)	2RX
802.11be (EHT20)	Support	2TX (Nss 1 / Nss 2)	2RX
802.11be (EHT40)	Support	2TX (Nss 1 / Nss 2)	2RX
802.11be (EHT80)	Support	2TX (Nss 1 / Nss 2)	2RX
802.11be (EHT160)	Support	2TX (Nss 1 / Nss 2)	2RX
802.11be (EHT320)	Support	2TX (Nss 1 / Nss 2)	2RX

Note:

1. All of modulation mode support beamforming function except 802.11a modulation mode.
2. The EUT support Beamforming and CDD mode, therefore both mode were investigated and the worst case scenario was identified. The worst case data were presented in test report.
3. The modulation and bandwidth are similar for 802.11ax mode for 20 MHz (40 MHz, 80 MHz, 160MHz), and 802.11be mode for 20 MHz (40 MHz, 80 MHz, 160MHz, 320MHz), therefore the manufacturer will control the power for 802.11ax mode is the same as the 802.11be or lower than it and investigated worst case to representative mode in test report.
4. The EUT device modulation technique OFDMA does not support partial RUs (resource units) and channel puncturing/bandwidth reduction mechanisms.

3.3 Channel List

U-NII-5:

16 channels are provided for 802.11a, 802.11ax (HE20), 802.11be (EHT20):

Channel	Frequency	Channel	Frequency	Channel	Frequency	Channel	Frequency
33	6115 MHz	37	6135 MHz	41	6155 MHz	45	6175 MHz
49	6195 MHz	53	6215 MHz	57	6235 MHz	61	6255 MHz
65	6275 MHz	69	6295 MHz	73	6315 MHz	77	6335 MHz
81	6355 MHz	85	6375 MHz	89	6395 MHz	93	6415 MHz

8 channels are provided for 802.11ax (HE40), 802.11be (EHT40):

Channel	Frequency	Channel	Frequency	Channel	Frequency	Channel	Frequency
35	6125 MHz	43	6165 MHz	51	6205 MHz	59	6245 MHz
67	6285 MHz	75	6325 MHz	83	6365 MHz	91	6405 MHz

4 channels are provided for 802.11ax (HE80), 802.11be (EHT80):

Channel	Frequency	Channel	Frequency	Channel	Frequency	Channel	Frequency
39	6145 MHz	55	6225 MHz	71	6305 MHz	87	6385 MHz

2 channels are provided for 802.11ax (HE160), 802.11be (EHT160):

Channel	Frequency	Channel	Frequency
47	6185 MHz	79	6345 MHz

1 channel is provided for 802.11be (EHT320):

Channel	Frequency
63	6265 MHz

U-NII-6:

5 channels are provided for 802.11a, 802.11ax (HE20), 802.11be (EHT20):

Channel	Frequency	Channel	Frequency	Channel	Frequency	Channel	Frequency
97	6435 MHz	101	6455 MHz	105	6475 MHz	109	6495 MHz
113	6515 MHz						

3 channels are provided for 802.11ax (HE40), 802.11be (EHT40):

Channel	Frequency	Channel	Frequency	Channel	Frequency
99	6445 MHz	107	6485 MHz	*115	6525 MHz

1 channel is provided for 802.11ax (HE80), 802.11be (EHT80):

Channel	Frequency
103	6465 MHz

1 channel is provided for 802.11ax (HE160), 802.11be (EHT160):

Channel	Frequency
*111	6505 MHz

1 channel is provided for 802.11be (EHT320):

Channel	Frequency
*95	6425 MHz

U-NII-7:

17 channels are provided for 802.11a, 802.11ax (HE20), 802.11be (EHT20):

Channel	Frequency	Channel	Frequency	Channel	Frequency	Channel	Frequency
117	6535 MHz	121	6555 MHz	125	6575 MHz	129	6595 MHz
133	6615 MHz	137	6635 MHz	141	6655 MHz	145	6675 MHz
149	6695 MHz	153	6715 MHz	157	6735 MHz	161	6755 MHz
165	6775 MHz	169	6795 MHz	173	6815 MHz	177	6835 MHz
181	6855 MHz						

8 channels are provided for 802.11ax (HE40), 802.11be (EHT40):

Channel	Frequency	Channel	Frequency	Channel	Frequency	Channel	Frequency
123	6565 MHz	131	6605 MHz	139	6645 MHz	147	6685 MHz
155	6725 MHz	163	6765 MHz	171	6805 MHz	179	6845 MHz

5 channels are provided for 802.11ax (HE80), 802.11be (EHT80):

Channel	Frequency	Channel	Frequency	Channel	Frequency	Channel	Frequency
*119	6545 MHz	135	6625 MHz	151	6705 MHz	167	6785 MHz
*183	6865 MHz						

2 channels are provided for 802.11ax (HE160), 802.11be (EHT160):

Channel	Frequency	Channel	Frequency
143	6665 MHz	175	*6825 MHz

2 channels are provided for 802.11be (EHT320):

Channel	Frequency	Channel	Frequency
*127	6585 MHz	*159	6745 MHz

U-NII-8:

13 channels are provided for 802.11a, 802.11ax (HE20), 802.11be (EHT20):

Channel	Frequency	Channel	Frequency	Channel	Frequency	Channel	Frequency
185	6875 MHz	189	6895 MHz	193	6915 MHz	197	6935 MHz
201	6955 MHz	205	6975 MHz	209	6995 MHz	213	7015 MHz
217	7035 MHz	221	7055 MHz	225	7075 MHz	229	7095 MHz
233	7115 MHz						

6 channels are provided for 802.11ax (HE40), 802.11be (EHT40):

Channel	Frequency	Channel	Frequency	Channel	Frequency	Channel	Frequency
187	6885 MHz	195	6925 MHz	203	6965 MHz	211	7005 MHz
219	7045 MHz	227	7085 MHz				

2 channels are provided for 802.11ax (HE80), 802.11be (EHT80):

Channel	Frequency	Channel	Frequency
199	6945 MHz	215	7025 MHz

1 channel is provided for 802.11ax (HE160), 802.11be (EHT160):

Channel	Frequency
207	6985 MHz

1 channel is provided for 802.11be (EHT320):

Channel	Frequency
*191	6905 MHz

Note: * mean these are straddle channels.

3.4 Test Mode Applicability and Tested Channel Detail

Pre-Scan:	The AC Adapter has the following models: ADS-40FPC-12 12030E / 2AED030FC / AD2150F10 / AD2150M20. Pre-scan these models of AC Adapters and find the worst case as a representative test condition.
Worst Case:	1. AC Adapter Worst Condition: ADS-40FPC-12 12030E 2. The EUT is usually used standing that and was therefore chosen for Unwanted Emissions.

Following channel(s) was (were) selected for the final test as listed below:

Test Item	EUT Configure Mode	Mode	Signal Mode	Tested Channel	Modulation	Data Rate Parameter
Maximum RF Output Power / Maximum Power Spectral Density	A	802.11a	CDD	33, 61, 93, 97, 105, 113, 117, 149, 181, 185, 209, 229, 233	BPSK	6Mb/s
		802.11be (EHT20)	Beamforming(2T1S) / Beamforming(2T2S)	33, 61, 93, 97, 105, 113, 117, 149, 181, 185, 209, 229, 233	BPSK	MCS0
		802.11be (EHT40)	Beamforming(2T1S) / Beamforming(2T2S)	35, 59, 91, 99, 107, 115, 123, 155, 179, 187, 211, 227	BPSK	MCS0
		802.11be (EHT80)	Beamforming(2T1S) / Beamforming(2T2S)	39, 55, 87, 103, 119, 135, 151, 167, 183, 199, 215	BPSK	MCS0
		802.11be (EHT160)	Beamforming(2T1S) / Beamforming(2T2S)	47, 79, 111, 143, 175, 207	BPSK	MCS0
		802.11be (EHT320)	Beamforming(2T1S) / Beamforming(2T2S)	63, 95, 127, 159, 191	BPSK	MCS0
Emission Bandwidth	A	802.11a	CDD	33, 61, 93, 97, 105, 113, 117, 149, 181, 185, 209, 229, 233	BPSK	6Mb/s
		802.11be (EHT20)	Beamforming(2T1S) / Beamforming(2T2S)	33, 61, 93, 97, 105, 113, 117, 149, 181, 185, 209, 229, 233	BPSK	MCS0
		802.11be (EHT40)	Beamforming(2T1S) / Beamforming(2T2S)	35, 59, 91, 99, 107, 115, 123, 155, 179, 187, 211, 227	BPSK	MCS0
		802.11be (EHT80)	Beamforming(2T1S) / Beamforming(2T2S)	39, 55, 87, 103, 119, 135, 151, 167, 183, 199, 215	BPSK	MCS0
		802.11be (EHT160)	Beamforming(2T1S) / Beamforming(2T2S)	47, 79, 111, 143, 175, 207	BPSK	MCS0
		802.11be (EHT320)	Beamforming(2T1S) / Beamforming(2T2S)	63, 95, 127, 159, 191	BPSK	MCS0

Test Item	EUT Configure Mode	Mode	Signal Mode	Tested Channel	Modulation	Data Rate Parameter
In-Band Emission Mask	A	802.11a	CDD	33, 61, 93, 97, 105, 113, 117, 149, 181, 185, 209, 229, 233	BPSK	6Mb/s
		802.11be (EHT20)	Beamforming(2T1S) / Beamforming(2T2S)	33, 61, 93, 97, 105, 113, 117, 149, 181, 185, 209, 229, 233	BPSK	MCS0
		802.11be (EHT40)	Beamforming(2T1S) / Beamforming(2T2S)	35, 59, 91, 99, 107, 115, 123, 155, 179, 187, 211, 227	BPSK	MCS0
		802.11be (EHT80)	Beamforming(2T1S) / Beamforming(2T2S)	39, 55, 87, 103, 119, 135, 151, 167, 183, 199, 215	BPSK	MCS0
		802.11be (EHT160)	Beamforming(2T1S) / Beamforming(2T2S)	47, 79, 111, 143, 175, 207	BPSK	MCS0
		802.11be (EHT320)	Beamforming(2T1S) / Beamforming(2T2S)	63, 95, 127, 159, 191	BPSK	MCS0
Occupied Bandwidth	A	802.11a	CDD	33, 61, 93, 97, 105, 113, 117, 149, 181, 185, 209, 229, 233	BPSK	6Mb/s
		802.11be (EHT20)	Beamforming(2T1S) / Beamforming(2T2S)	33, 61, 93, 97, 105, 113, 117, 149, 181, 185, 209, 229, 233	BPSK	MCS0
		802.11be (EHT40)	Beamforming(2T1S) / Beamforming(2T2S)	35, 59, 91, 99, 107, 115, 123, 155, 179, 187, 211, 227	BPSK	MCS0
		802.11be (EHT80)	Beamforming(2T1S) / Beamforming(2T2S)	39, 55, 87, 103, 119, 135, 151, 167, 183, 199, 215	BPSK	MCS0
		802.11be (EHT160)	Beamforming(2T1S) / Beamforming(2T2S)	47, 79, 111, 143, 175, 207	BPSK	MCS0
		802.11be (EHT320)	Beamforming(2T1S) / Beamforming(2T2S)	63, 95, 127, 159, 191	BPSK	MCS0
Frequency Stability	A	802.11a	CDD	33	un-modulation	-
Contention-based Protocol	A, B	802.11be (EHT20)	Normal	65, 101, 149, 209	BPSK	MCS0
		802.11be (EHT320)	Normal	63, 95, 127, 191	BPSK	MCS0



Test Item	EUT Configure Mode	Mode	Signal Mode	Tested Channel	Modulation	Data Rate Parameter
AC Power Conducted Emissions	A, B	802.11be (EHT320)	Beamforming	95	BPSK	MCS0
Unwanted Emissions below 1 GHz	A, B	802.11be (EHT320)	Beamforming	95	BPSK	MCS0
Unwanted Emissions above 1 GHz	A	802.11a	CDD	33, 61, 93, 97, 105, 113, 117, 149, 181, 185, 209, 229, 233	BPSK	6Mb/s
		802.11be (EHT20)	Beamforming(2T1S) / Beamforming(2T2S)	33, 61, 93, 97, 105, 113, 117, 149, 181, 185, 209, 229, 233	BPSK	MCS0
		802.11be (EHT40)	Beamforming(2T1S) / Beamforming(2T2S)	35, 59, 91, 99, 107, 115, 123, 155, 179, 187, 211, 227	BPSK	MCS0
		802.11be (EHT80)	Beamforming(2T1S) / Beamforming(2T2S)	39, 55, 87, 103, 119, 151, 183, 199, 215	BPSK	MCS0
		802.11be (EHT160)	Beamforming(2T1S) / Beamforming(2T2S)	47, 79, 111, 143, 175, 207	BPSK	MCS0
		802.11be (EHT320)	Beamforming(2T1S) / Beamforming(2T2S)	63, 95, 127, 159, 191	BPSK	MCS0
EUT Configure Mode:	A	EUT (Model: RBE771) powered by Adapter 1				
	B	EUT (Model: RBE770) powered by Adapter 1				

3.5 Duty Cycle of Test Signal

802.11a: Duty cycle = 1.985 ms / 1.99 ms x 100% = 99.7%

Beamforming (2T1S and 2T2S duty cycle are very similar, so choose worst mode record in the test report.)

802.11be (EHT20): Duty cycle = 5.168 ms / 5.219 ms x 100% = 99.0%

802.11be (EHT40): Duty cycle = 5.151 ms / 5.219 ms x 100% = 98.7%

802.11be (EHT80): Duty cycle = 5.4 ms / 5.505 ms x 100% = 98.1%

802.11be (EHT160): Duty cycle = 5.22 ms / 5.3 ms x 100% = 98.5%

802.11be (EHT320): Duty cycle = 2.65 ms / 2.68 ms x 100% = 98.9%

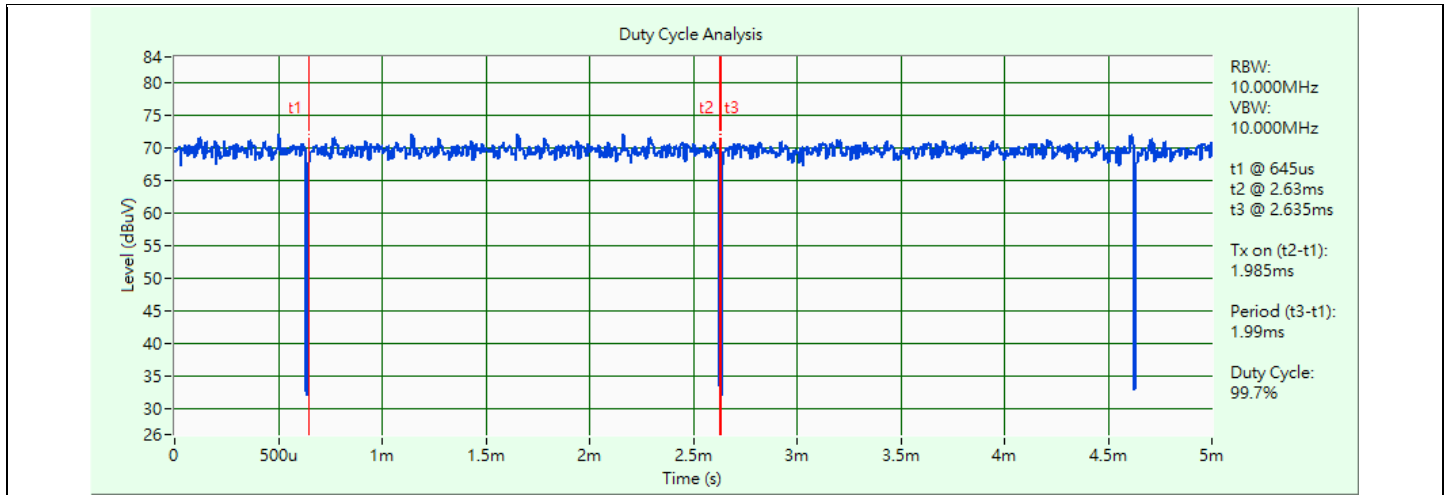

802.11a

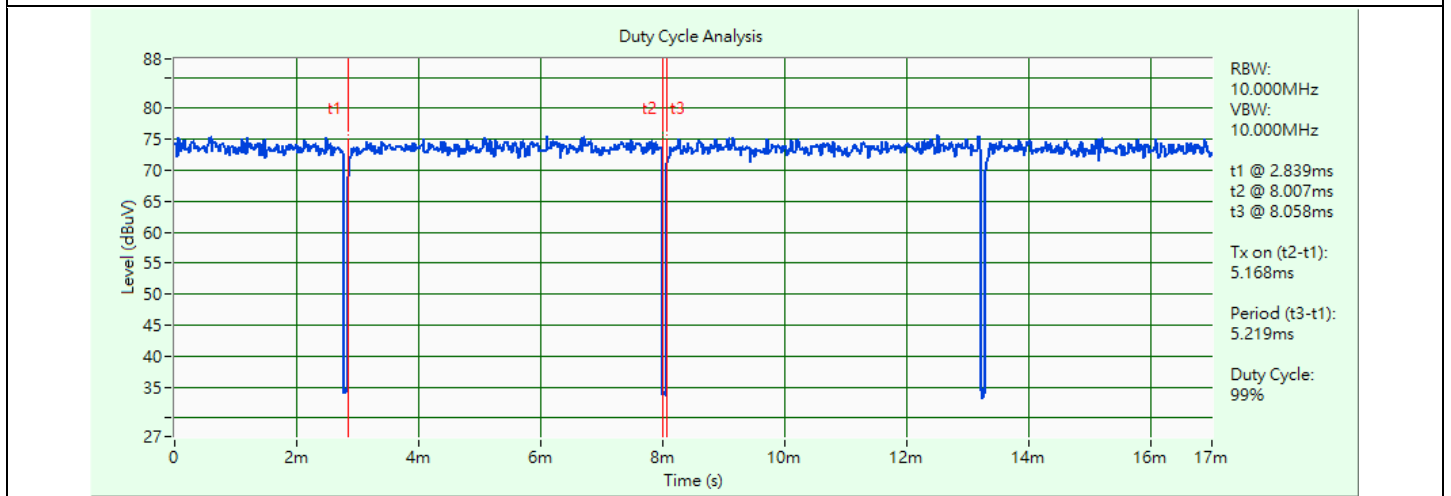

802.11be (EHT20)

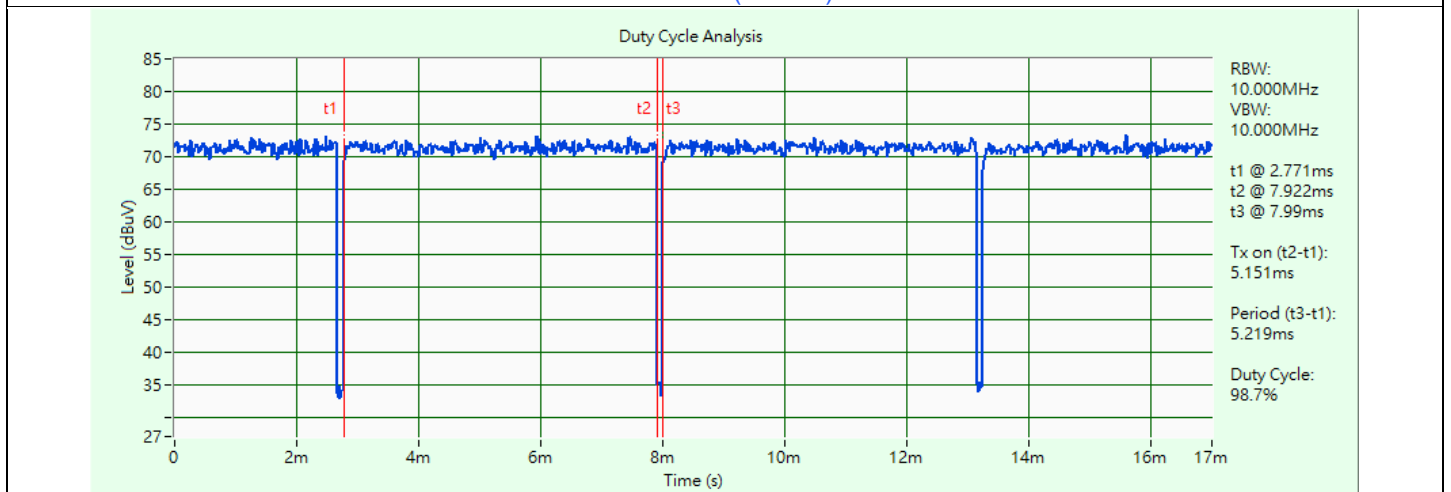

802.11be (EHT40)

Duty Cycle Analysis

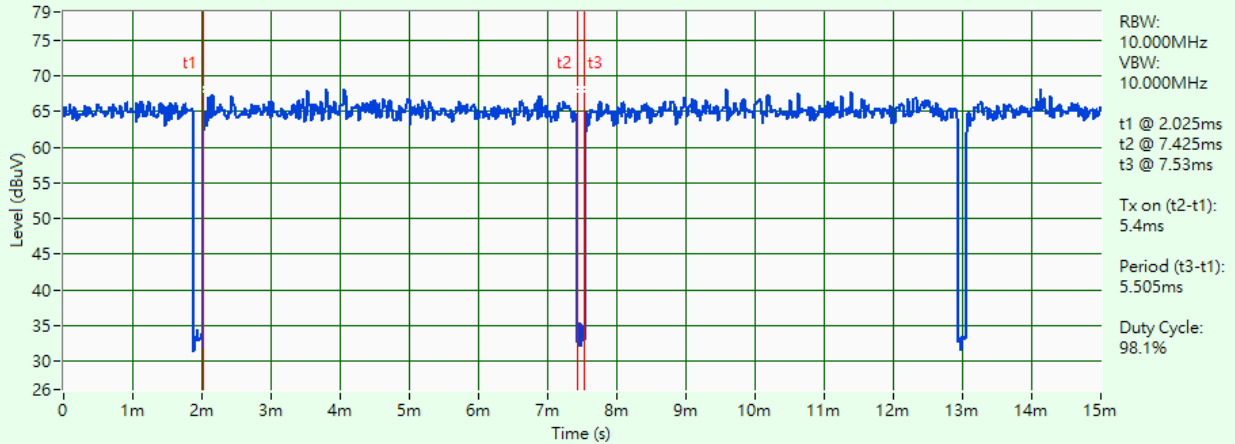

802.11be (EHT80)

Duty Cycle Analysis

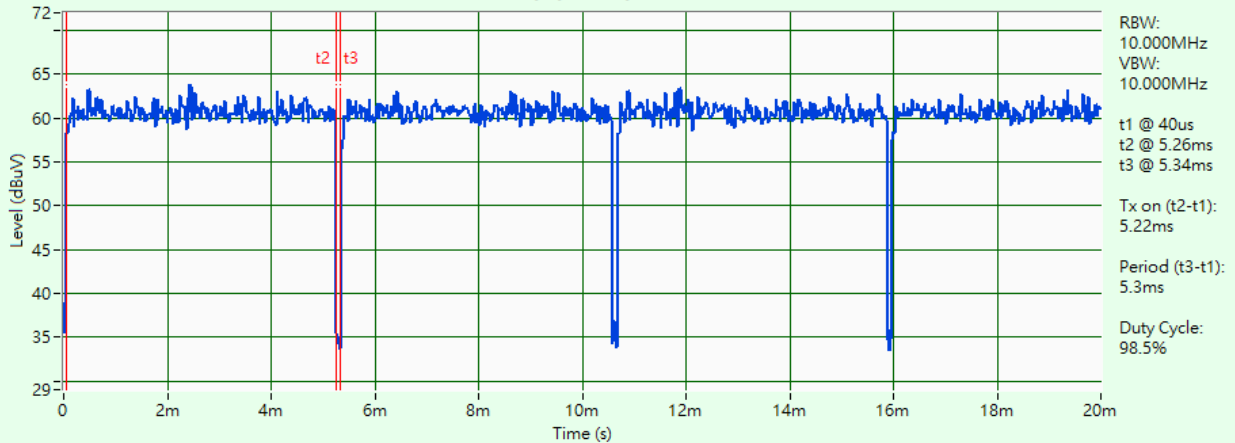

802.11be (EHT160)

Duty Cycle Analysis

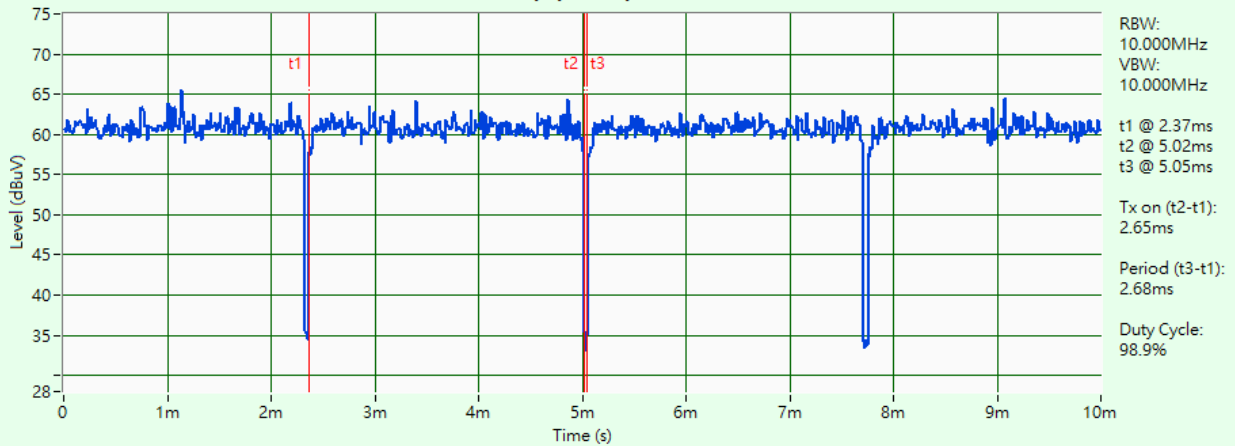

802.11be (EHT320)

3.6 Test Program Used and Operation Descriptions

Controlling software QSPR Version 5.0-00202 has been activated to set the EUT under transmission condition continuously at specific channel frequency.

3.7 Connection Diagram of EUT and Peripheral Devices

Mode A

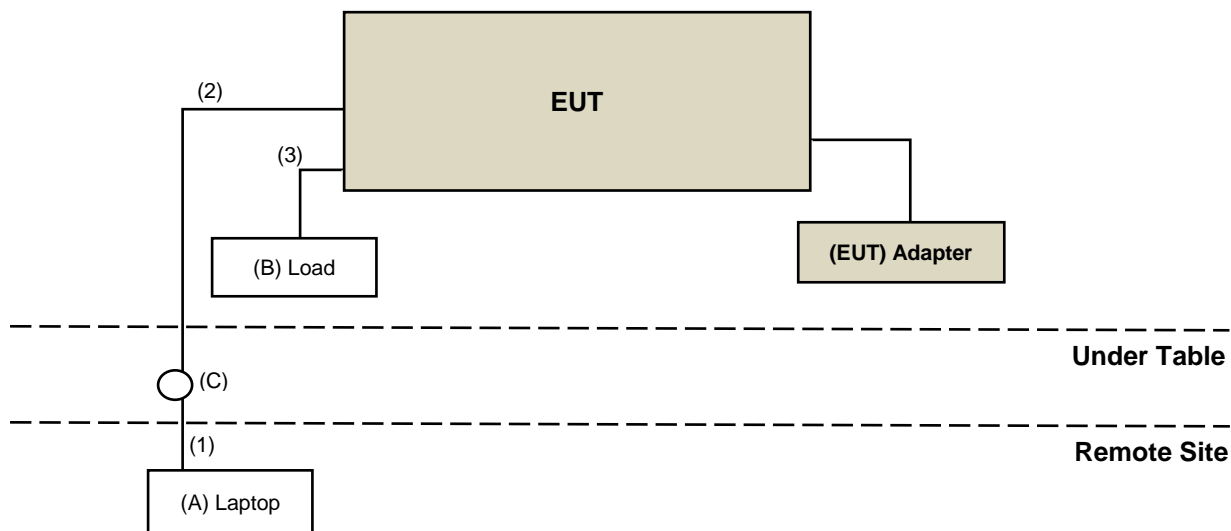

Mode B

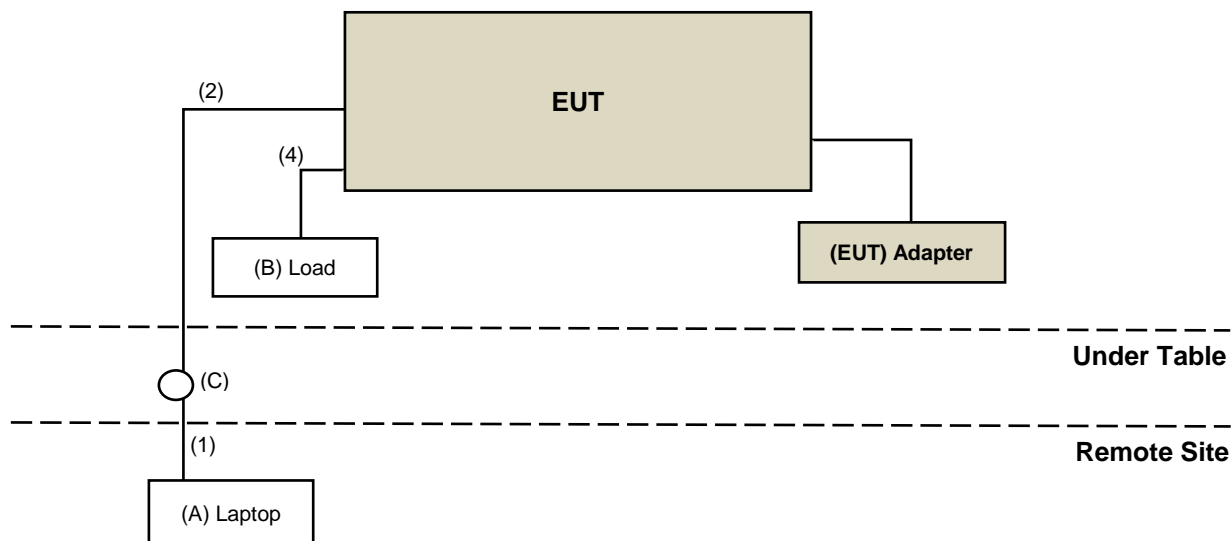

3.8 Configuration of Peripheral Devices and Cable Connections

ID	Product	Brand	Model No.	Serial No.	FCC ID	Remarks
A.	Laptop	DELL	E5430	2RL3YW1	NA	Provided by Lab
B.	Load	N/A	N/A	N/A	N/A	Provided by Lab
C.	LAN to LAN	N/A	N/A	N/A	N/A	Provided by Lab

No.	Cable Descriptions	Qty.	Length (m)	Shielded (Yes/ No)	Cores (Qty.)	Remark
1.	RJ-45 Cable	1	10	No	0	Provided by Lab
2.	Ethernet Cable	1	2	No	0	Accessory of EUT
3.	RJ-45 Cable	3	1.5	No	0	Provided by Lab
4.	RJ-45 Cable	1	2	No	0	Supplied by applicant

4 Test Instruments

The calibration interval of the all test instruments are 12 months and the calibrations are traceable to NML/ROC and NIST/USA.

4.1 Maximum RF Output Power

Description Manufacturer	Model No.	Serial No.	Calibrated Date	Calibrated Until
Antenna Tower inn-co GmbH	MA 4000	010303	N/A	N/A
EMI Test Receiver R&S	ESR3	102782	2023/12/7	2024/12/6
Horn Antenna Schwarzbeck	BBHA 9120D	9120D-408	2023/11/12	2024/11/11
Preamplifier Keysight	83017A	MY53270295	2023/5/7	2024/5/6
RF Coaxial Cable HUBER+SUHNER	SUCOFLEX 104	Cable-CH4-03(250724)	2023/5/7	2024/5/6
	Sucoflex 104	MY 13380+295012/04	2023/5/7	2024/5/6
Signal & Spectrum Analyzer R&S	FSW43	101582	2023/4/13	2024/4/12
Software BV ADT	ADT_Radiated_ V7.6.15.9.5	N/A	N/A	N/A
Turn Table BV ADT	TT100	TT93021705	N/A	N/A
Turn Table Controller BV ADT	SC100	SC93021705	N/A	N/A

Notes:

1. The test was performed in HY - 966 chamber 3.
2. Tested Date: 2024/1/5 ~ 2024/2/19

4.2 Maximum Power Spectral Density

Refer to section 4.1 to get information of the instruments.

4.3 Emission Bandwidth

Description Manufacturer	Model No.	Serial No.	Calibrated Date	Calibrated Until
Signal & Spectrum Analyzer R&S	FSV3044	101504	2023/6/5	2024/6/4
Software BV	ADT_RF Test Software V7.6.5.4	N/A	N/A	N/A

Notes:

1. The test was performed in Oven room.
2. Tested Date: 2024/2/19

4.4 In-Band Emission Mask

Refer to section 4.3 to get information of the instruments.

4.5 Occupied Bandwidth

Refer to section 4.3 to get information of the instruments.

4.6 Frequency Stability

Description Manufacturer	Model No.	Serial No.	Calibrated Date	Calibrated Until
AC Power Supply JIN YIH Technology	6905S	1720444	N/A	N/A
Digital Multimeter Fluke	87-III	70360742	2023/7/6	2024/7/5
Signal & Spectrum Analyzer R&S	FSV3044	101504	2023/6/5	2024/6/4
Software BV	ADT_RF Test Software V7.6.5.4	N/A	N/A	N/A
Temperature & Humidity Chamber Terchy	HRM-120RF	931022	2023/12/19	2024/12/18

Notes:

1. The test was performed in Oven room.
2. Tested Date: 2024/2/19

4.7 Contention-based Protocol

Description Manufacturer	Model No.	Serial No.	Calibrated Date	Calibrated Until
EXA Signal Analyzer Agilent	N9010A	MY52220207	2023/1/3	2024/1/2
MXG Vector Signal Generator Agilent	N5182B	MY53050430	2023/12/4	2024/12/3
MXG Vector Signal Generator Keysight	N5182BU	MY59360189	2023/12/4	2024/12/3
Power Divider Woken	0120A02058001M	DCMD33WIK3	2023/5/5	2024/5/4
		DCMD33WIK7	2023/5/5	2024/5/4

Notes:

1. The test was performed in Adaptivity room.
2. Tested Date: 2023/12/19 ~ 2023/12/26

4.8 AC Power Conducted Emissions

Description Manufacturer	Model No.	Serial No.	Calibrated Date	Calibrated Until
50 ohm terminal resistance HUBER+SUHNER	E1-011276	01	2023/2/1	2024/1/31
	E1-011312	10	2023/1/30	2024/1/29
	E1-011591	17	2023/2/1	2024/1/31
DC-LISN Schwarzbeck	NNBM 8126G	8126G-069	2023/11/7	2024/11/6
EMI Test Receiver R&S	ESCI	100613	2023/12/4	2024/12/3
Fixed Attenuator Mini-Circuits	HAT-10+	PAD-COND1-01	2023/1/7 2024/1/6	2024/1/6 2025/1/5
LISN R&S	ENV216	101826	2023/3/23	2024/3/22
	ESH3-Z5	100311	2023/9/6	2024/9/5
RF Coaxial Cable Woken	5D-FB	Cable-cond1-01	2023/1/7 2024/1/6	2024/1/6 2025/1/5
Software BVADT	BVADT_Cond_ V7.3.7.4	N/A	N/A	N/A
V-LISN Schwarzbeck	NNBL 8226-2	8226-142	2023/8/31	2024/8/30

Notes:

1. The test was performed in HY - Conduction 1.
2. Tested Date: 2024/1/5 ~ 2024/1/15

4.9 Unwanted Emissions below 1 GHz

Description Manufacturer	Model No.	Serial No.	Calibrated Date	Calibrated Until
Antenna Tower inn-co GmbH	MA 4000	010303	N/A	N/A
Bi_Log Antenna Schwarzbeck	VULB 9168	9168-155	2023/10/13	2024/10/12
EMI Test Receiver R&S	ESR3	102782	2023/12/7	2024/12/6
Loop Antenna Electro-Metrics	EM-6879	269	2023/9/23	2024/9/22
Loop Antenna TESEQ	HLA 6121	45745	2023/8/8	2024/8/7
Preamplifier Agilent	8447D	2944A10631	2023/5/7	2024/5/6
Preamplifier EMCI	EMC001340	980201	2023/9/27	2024/9/26
RF Coaxial Cable Woken	8D-FB	Cable-CH4-01	2023/7/8	2024/7/7
Signal & Spectrum Analyzer R&S	FSW43	101582	2023/4/13	2024/4/12
Software BV ADT	ADT_Radiated_ V7.6.15.9.5	N/A	N/A	N/A
Turn Table BV ADT	TT100	TT93021705	N/A	N/A
Turn Table Controller BV ADT	SC100	SC93021705	N/A	N/A

Notes:

1. The test was performed in HY - 966 chamber 3.
2. Tested Date: 2024/1/4 ~ 2024/1/15

4.10 Unwanted Emissions above 1 GHz

Description Manufacturer	Model No.	Serial No.	Calibrated Date	Calibrated Until
Antenna Tower inn-co GmbH	MA 4000	010303	N/A	N/A
Boresight antenna tower fixture BV	BAF-02	5	N/A	N/A
EMI Test Receiver R&S	ESR3	102782	2023/12/7	2024/12/6
Horn Antenna Schwarzbeck	BBHA 9120D	9120D-408	2023/11/12	2024/11/11
	BBHA 9170	9170-480	2023/11/12	2024/11/11
		BBHA9170241	2023/10/16	2024/10/15
		BBHA9170243	2023/11/12	2024/11/11
Preamplifier EMCI	EMC 184045	980116	2023/9/27	2024/9/26
Preamplifier Keysight	83017A	MY53270295	2023/5/7	2024/5/6
RF Coaxial Cable EMCI	EMC102-KM-KM-600	150928	2023/7/8	2024/7/7
	EMC102-KM-KM-3000	150929	2023/7/8	2024/7/7
RF Coaxial Cable HUBER+SUHNER	SUCOFLEX 104	Cable-CH4-03(250724)	2023/5/7	2024/5/6
	Sucoflex 104	MY 13380+295012/04	2023/5/7	2024/5/6
Signal & Spectrum Analyzer R&S	FSW43	101582	2023/4/13	2024/4/12
Software BV ADT	ADT_Radiated_ V7.6.15.9.5	N/A	N/A	N/A
Turn Table BV ADT	TT100	TT93021705	N/A	N/A
Turn Table Controller BV ADT	SC100	SC93021705	N/A	N/A

Notes:

1. The test was performed in HY - 966 chamber 3.
2. Tested Date: 2023/12/27 ~ 2024/1/3

5 Limits of Test Items

5.1 Maximum RF Output Power

Operation Band	Equipment Class	Limit
		Maximum Average Power
U-NII-5 U-NII-6 U-NII-7 U-NII-8	6ID: 15E 6 GHz Low-power indoor access point	EIRP 30 dBm

5.2 Maximum Power Spectral Density

Operation Band	Equipment Class	Limit
		Maximum Power Density
U-NII-5 U-NII-6 U-NII-7 U-NII-8	6ID: 15E 6 GHz Low-power indoor access point	EIRP 5 dBm/MHz

5.3 Emission Bandwidth

The maximum transmitter channel bandwidth for U-NII devices in the 5.925-7.125 GHz band is 320 MHz.

5.4 In-Band Emission Mask

Test Item	Frequencies (MHz)	(X) dB ^{*1}
Emission Mask	At 1 MHz outside of channel edge	20
	At one channel bandwidth from the channel center ^{*2}	28
	At one- and one-half times the channel bandwidth away from channel center ^{*3}	40
	More than one- and one-half times the channel bandwidth	40

^{*1} : The power spectral density must be suppressed by "x" dB

^{*2} : At frequencies between one megahertz outside an unlicensed device's channel edge and one channel bandwidth from the center of the channel, the limits must be linearly interpolated between 20 dB and 28 dB suppression,

^{*3} : At frequencies between one and one- and one-half times an unlicensed device's channel bandwidth, the limits must be linearly interpolated between 28 dB and 40 dB suppression.

5.5 Occupied Bandwidth

The maximum transmitter channel bandwidth for U-NII devices in the 5.925-7.125 GHz band is 320 MHz.

5.6 Frequency Stability

The frequency of the carrier signal shall be maintained within band of operation.

5.7 Contention-based Protocol

Unlicensed indoor low-power devices must detect co-channel radio frequency power that is at least -62 dBm (The threshold is referenced to a 0 dBi antenna gain.) or lower. Additionally, indoor low-power devices must detect co-channel energy with 90% or greater certainty.

5.8 AC Power Conducted Emissions

Frequency (MHz)	Conducted Limit (dBuV)	
	Quasi-peak	Average
0.15 - 0.5	66 - 56	56 - 46
0.50 - 5.0	56	46
5.0 - 30.0	60	50

Notes:

1. The lower limit shall apply at the transition frequencies.
2. The limit decreases in line with the logarithm of the frequency in the range of 0.15 to 0.50 MHz.

5.9 Unwanted Emissions below 1 GHz

Radiated emissions which fall in the restricted bands must comply with the radiated emission limits specified as below table.

Frequencies (MHz)	Field Strength (microvolts/meter)	Measurement Distance (meters)
0.009 ~ 0.490	2400/F(kHz)	300
0.490 ~ 1.705	24000/F(kHz)	30
1.705 ~ 30.0	30	30
30 ~ 88	100	3
88 ~ 216	150	3
216 ~ 960	200	3
Above 960	500	3

Notes:

1. The lower limit shall apply at the transition frequencies.
2. Emission level (dBuV/m) = 20 log Emission level (uV/m).

5.10 Unwanted Emissions above 1 GHz

Radiated emissions which fall in the restricted bands must comply with the radiated emission limits specified as below table.

Frequencies (MHz)	Field Strength (microvolts/meter)	Measurement Distance (meters)
Above 960	500	3

Notes:

1. The lower limit shall apply at the transition frequencies.
2. Emission level (dBuV/m) = 20 log Emission level (uV/m).
3. For frequencies above 1000 MHz, the field strength limits are based on average detector, however, the peak field strength of any emission shall not exceed the maximum permitted average limits, specified above by more than 20 dB under any condition of modulation.

Limits of unwanted emission out of the restricted bands

Frequencies (MHz)	EIRP Limit	Equivalent Field Strength at 3 m
5925 MHz > F > 7125 MHz	Peak: -7 (dBm/MHz)	88.2 (dBuV/m)
	Average: -27 (dBm/MHz)	68.2 (dBuV/m)

Note: The following formula is used to convert the equipment isotropic radiated power (eirp) to field strength:

$$E = \frac{1000000\sqrt{30P}}{3} \mu\text{V/m, where P is the eirp (Watts).}$$

6 Test Arrangements

6.1 Maximum RF Output Power

6.1.1 Test Setup

Radiated Measurement Method

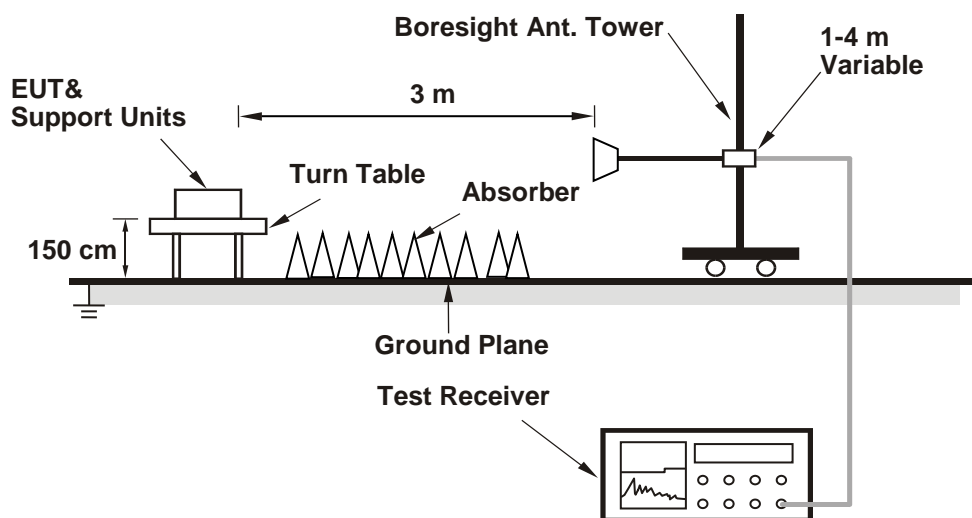

6.1.2 Test Procedure

Radiated Measurement Method

- The EUT was placed on the top of a rotating table 1.5 meters above the ground at 3 meter chamber room for test. The table was rotated 360 degrees to determine the position of the highest radiation.
- The EUT was set 3 meters away from the interference-receiving antenna, which was mounted on the top of a variable-height antenna tower.
- The height of antenna is varied from one meter to four meters above the ground to determine the maximum value of the field strength. Both horizontal and vertical polarizations of the antenna are set to make the measurement.
- Perform a field strength measurement and record the worse read value, is the field strength value via a spectrum reading obtained corrected for antenna factor, cable loss and pre-amplifier factor and then mathematically convert the measured field strength level to EIRP level.
- Follow ANSI C63.10 section 12.7.3, $EIRP \text{ Value (dBm)} = \text{Field Strength Value (dBuV / m)} + \text{Correction Factor @ 3 m}$.
- $\text{Correction Factor (dB) @ 3 m} = 20\log(D) - 104.77 = -95.23 \text{ dB}$; where D is the measurement distance @3 m.

Spectrum analyzer setting as below:

Method SA-1

- Set span to encompass the entire emission bandwidth (EBW) of the signal.
- Set RBW = 1 MHz, Set VBW \geq 3 MHz, Detector = RMS
- Sweep points $\geq [2 \times \text{span} / \text{RBW}]$. (This gives bin-to-bin spacing $\leq \text{RBW} / 2$, so that narrowband signals are not lost between frequency bins.)
- Sweep time = auto, trigger set to "free run".
- Trace average at least 100 traces in power averaging mode.
- Record the max value

Note: When measuring power, use compute power by integrating the spectrum across the 26 dB EBW or 99% OBW of the signal using the instrument's band power measurement function, with band limits set equal to the EBW or OBW band edges. If the instrument does not have a band power function, then sum the spectrum levels (in power units) at 1 MHz intervals extending across the 26 dB EBW or 99% OBW of the spectrum.

6.2 Maximum Power Spectral Density

6.2.1 Test Setup

Radiated Measurement Method

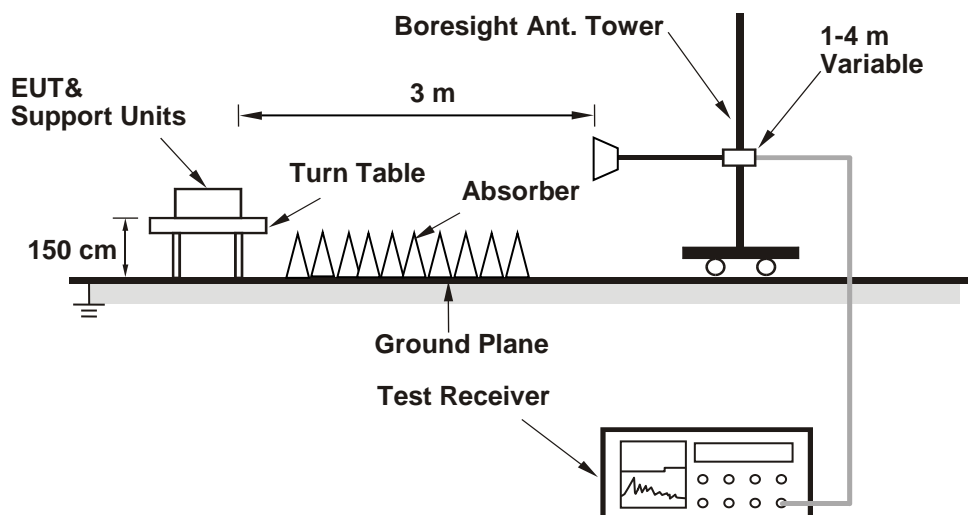

6.2.2 Test Procedure

Radiated Measurement Method

- The EUT was placed on the top of a rotating table 1.5 meters above the ground at 3 meter chamber room for test. The table was rotated 360 degrees to determine the position of the highest radiation.
- The EUT was set 3 meters away from the interference-receiving antenna, which was mounted on the top of a variable-height antenna tower.
- The height of antenna is varied from one meter to four meters above the ground to determine the maximum value of the field strength. Both horizontal and vertical polarizations of the antenna are set to make the measurement.
- Perform a field strength measurement and record the worse read value, is the field strength value via a spectrum reading obtained corrected for antenna factor, cable loss and pre-amplifier factor and then mathematically convert the measured field strength level to EIRP level.
- Follow ANSI C63.10 section 12.7.3, $EIRP \text{ Value (dBm)} = \text{Field Strength Value (dBuV/m)} + \text{Correction Factor @ 3 m}$.
- $\text{Correction Factor (dB) @ 3 m} = 20\log(D) - 104.77$; where D is the measurement distance @3 m = -95.23 dB

Spectrum analyzer setting as below:

Method SA-1

- Set span to encompass the entire emission bandwidth (EBW) of the signal.
- Set RBW = 1 MHz, Set VBW \geq 3 MHz, Detector = RMS
- Sweep points $\geq [2 \times \text{span} / \text{RBW}]$. (This gives bin-to-bin spacing $\leq \text{RBW} / 2$, so that narrowband signals are not lost between frequency bins.)
- Sweep time = auto, trigger set to "free run".
- Trace average at least 100 traces in power averaging mode.
- Record the max value

6.3 Emission Bandwidth

6.3.1 Test Setup

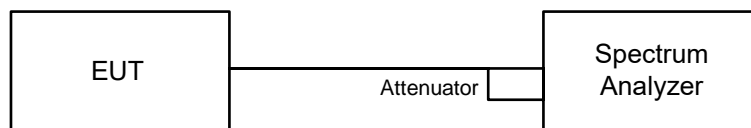

6.3.2 Test Procedure

- Set RBW = approximately 1% of the emission bandwidth.
- Set the VBW > RBW.
- Detector = Peak.
- Trace mode = max hold.
- Measure the maximum width of the emission that is 26 dB down from the peak of the emission. Compare this with the RBW setting of the analyzer. Readjust RBW and repeat measurement as needed until the RBW/EBW ratio is approximately 1%.

6.4 In-Band Emission Mask

6.4.1 Test Setup

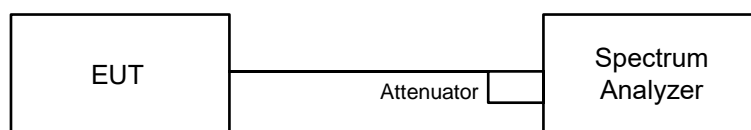

6.4.2 Test Procedure

- Connect output of the antenna port to a spectrum analyzer and adjust appropriate attenuation.
- Measure the 26 dB EBW using the test procedure 12.4.1 of ANSI C63.10-2013. (Determine the channel edge.)
- Measure the power spectral density (for emissions mask reference) using the following procedure:
 - Set the span to encompass the entire 26 dB EBW of the signal.
 - Set RBW = same RBW used for 26 dB EBW measurement.
 - Set VBW \geq [3 X RBW].
 - Number of points in sweep \geq [2 X span / RBW].
 - Sweep time = auto.
 - Detector = RMS (i.e., power averaging).
 - Trace average at least 100 traces in power averaging (rms) mode.
 - Use the peak search function on the instrument to find the peak of the spectrum.
- Using the measuring equipment limit line function, develop the emissions mask based on the following requirements. The emissions power spectral density must be reduced below the peak power spectral density (in dB) as follows:
 - Suppressed by 20 dB at 1 MHz outside of the channel edge. (The channel edge is defined as the 26-dB point on either side of the carrier center frequency.)
 - Suppressed by 28 dB at one channel bandwidth from the channel center.
 - Suppressed by 40 dB at one- and one-half times the channel bandwidth from the channel center.
- Adjust the span to encompass the entire mask as necessary and clear trace.
- Trace average at least 100 traces in power averaging (rms) mode.
- Adjust the reference level as necessary so that the crest of the channel touches the top of the emission mask

6.5 Occupied Bandwidth

6.5.1 Test Setup

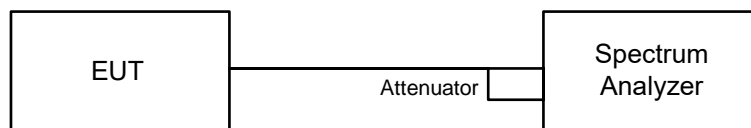

6.5.2 Test Procedure

The transmitter output was connected to the spectrum analyzer through an attenuator. The bandwidth of the fundamental frequency was measured by spectrum analyzer with resolution bandwidth in the range of 1% to 5% of the anticipated emission bandwidth, and a video bandwidth at least 3x the resolution bandwidth and set the detector to Sampling. The width of a frequency band such that, below the lower and above the upper frequency limits, the mean powers emitted are each equal to a specified percentage 0.5% of the total mean power of a given emission.

6.6 Frequency Stability

6.6.1 Test Setup

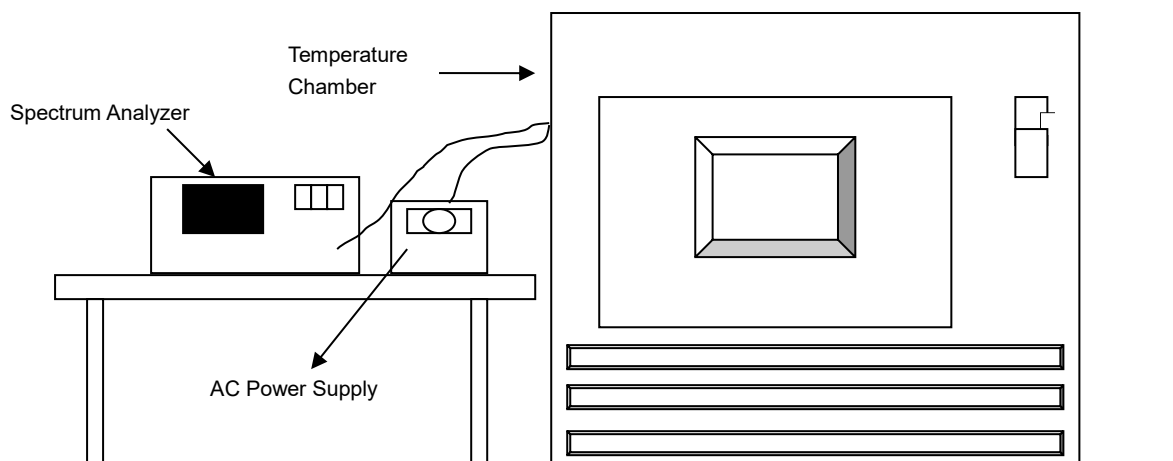

6.6.2 Test Procedure

- The EUT was placed inside the environmental test chamber and powered by nominal AC voltage.
- Turn the EUT on and couple its output to a spectrum analyzer.
- Turn the EUT off and set the chamber to the highest temperature specified.
- Allow sufficient time (approximately 30 min) for the temperature of the chamber to stabilize, turn the EUT on and measure the operating frequency after 2, 5, and 10 Minutes.
- Repeat step (d) with the temperature chamber set to the next desired temperature until measurements down to the lowest specified temperature have been completed.
- The test chamber was allowed to stabilize at +20 degree C for a minimum of 30 Minutes. The supply voltage was then adjusted on the EUT from 85% to 115% and the frequency record.

6.7 Contention-based Protocol

6.7.1 Test Setup

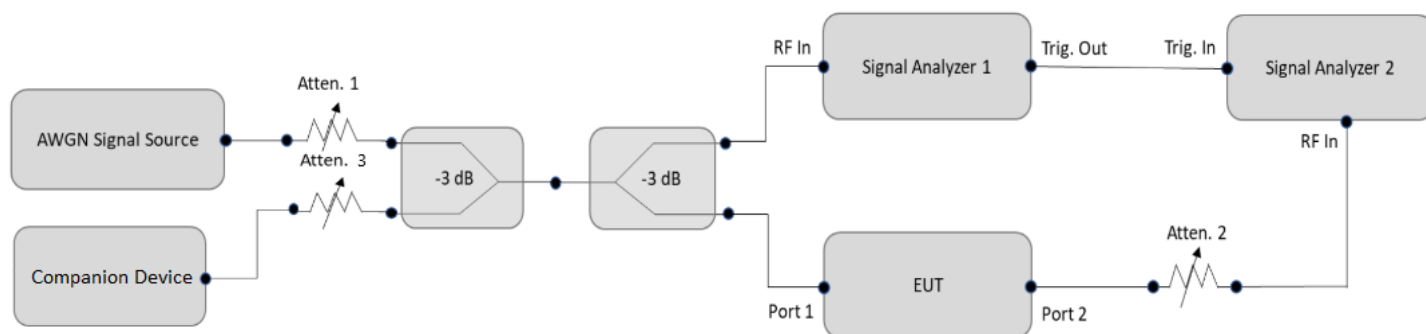

6.7.2 Test Procedure

- Set the signal analyzer center frequency to the nominal EUT channel center frequency. The span range of the signal analyzer shall be between two times and five times the OBW of the EUT. Connect the output port of the EUT to the signal analyzer 2. Ensure that the attenuator 2 provides enough attenuation to not overload the signal analyzer 2 receiver.
- Monitoring the signal analyzer 2, verify the EUT is operating and transmitting with the parameters (set as following section 4.7.5 EUT operating condition).
- Determine number of times detection threshold test as following table,

If	Number of Tests	Placement of Incumbent Transmission
$BW_{EUT} \leq BW_{Inc}$	Once	Same as EUT transmission
$BW_{Inc} < BW_{EUT} \leq 2x BW_{Inc}$	Once	Contained within BW_{EUT}
$2x BW_{Inc} < BW_{EUT} \leq 4x BW_{Inc}$	Twice. (Incumbent transmission is contained within BW_{EUT})	Closely to the lower edge and upper edge of the EUT Channel
$BW_{EUT} > 4x BW_{Inc}$	Three times	Closely to the lower edge, in the middle and upper edge of the EUT Channel

- Using an AWGN signal source, generate (but do not transmit, i.e., RF OFF) a 10 MHz-wide AWGN signal. Use step c table to determine the center frequency of the 10 MHz AWGN signal relative to the EUT's channel bandwidth and center frequency.
- Set the AWGN signal power to an extremely low level (more than 20 dB below the -62 dBm threshold). Connect the AWGN signal source, via a 3-dB splitter, to the signal analyzer 1 and the EUT.
- Transmit the AWGN signal (RF ON) and verify its characteristics on the signal analyzer 1.
- Monitor the signal analyzer 2 to verify if the AWGN signal has been detected and the EUT has ceased transmission. If the EUT continues to transmit, then incrementally increase the AWGN signal power level until the EUT stops transmitting.
- (Including all losses in the RF paths) Determine and record the AWGN signal power level (at the EUT's antenna port) at which the EUT ceased transmission. Repeat the procedure at least 10 times to verify the EUT can detect an AWGN signal with 90% (or better) level of certainty.
- Refer to step c table to determine number of times the detection threshold testing needs to be repeated. If testing is required more than once, then go back to step d, choose a different center frequency for the AWGN signal and repeat the process.

6.8 AC Power Conducted Emissions

6.8.1 Test Setup

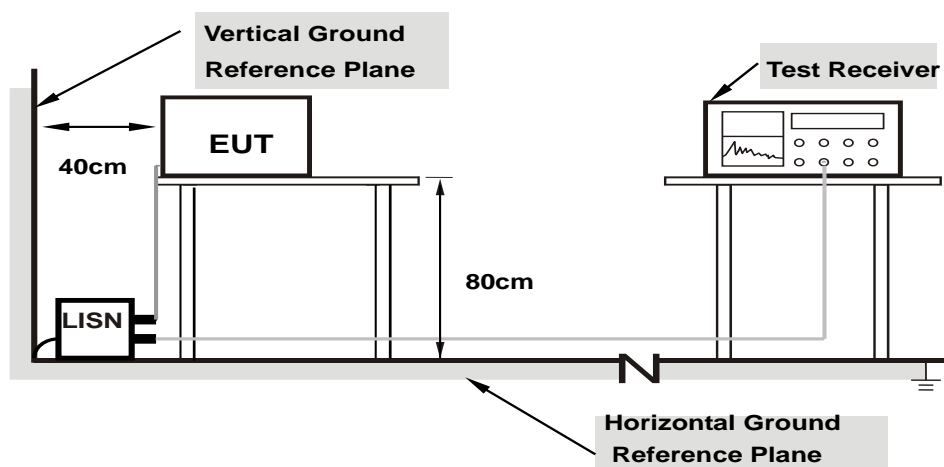

Note: 1.Support units were connected to second LISN.

For the actual test configuration, please refer to the attached file (Test Setup Photo).

6.8.2 Test Procedure

- The EUT was placed on a 0.8 meter to the top of table and placed 0.4 meters from the conducting wall of the shielded room with EUT being connected to the power mains through a line impedance stabilization network (LISN). Other support units were connected to the power mains through another LISN. The two LISNs provide 50 ohm/ 50 uH of coupling impedance for the measuring instrument.
- Both lines of the power mains connected to the EUT were checked for maximum conducted interference.
- The frequency range from 150 kHz to 30 MHz was searched. Emission levels under (Limit – 20 dB) was not recorded.

Note: The resolution bandwidth and video bandwidth of test receiver is 9 kHz for quasi-peak detection (QP) and average detection (AV) at frequency 0.15 MHz-30 MHz.

6.9 Unwanted Emissions below 1 GHz

6.9.1 Test Setup

For Radiated emission below 30 MHz

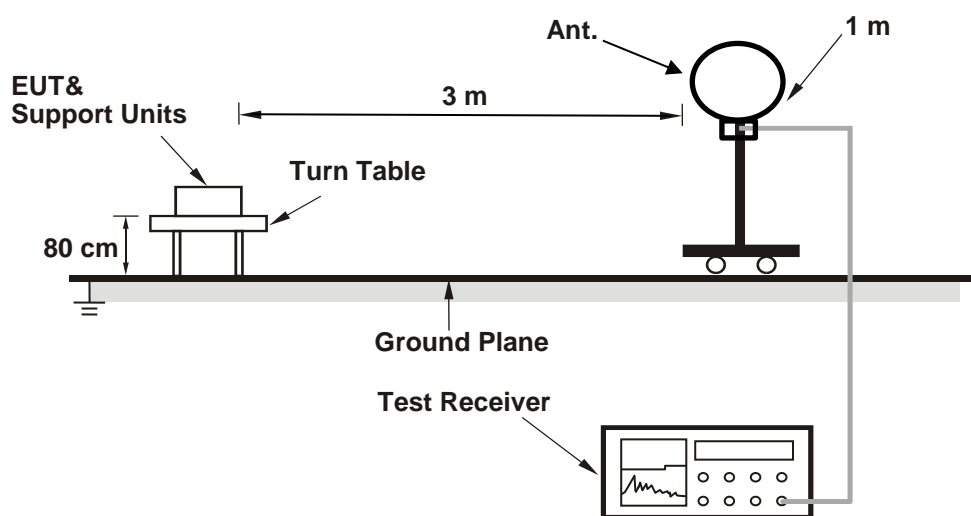

For Radiated emission above 30 MHz

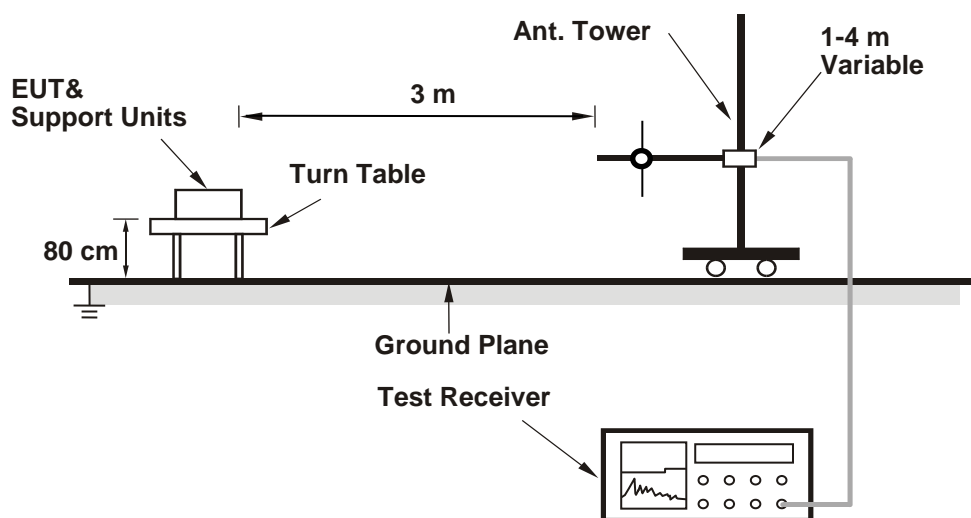

For the actual test configuration, please refer to the attached file (Test Setup Photo).

6.9.2 Test Procedure

For Radiated emission below 30 MHz

- a. The EUT was placed on the top of a rotating table 0.8 meters above the ground at 3 meter chamber room for test. The table was rotated 360 degrees to determine the position of the highest radiation.
- b. The EUT was set 3 meters away from the interference-receiving antenna, which was mounted on the top of a variable-height antenna tower.
- c. Parallel, perpendicular, and ground-parallel orientations of the antenna are set to make the measurement.
- d. For each suspected emission, the EUT was arranged to its worst case and the rotatable table was turned from 0 degrees to 360 degrees to find the maximum reading.
- e. The test-receiver system was set to Quasi-Peak Detect Function and Specified Bandwidth with Maximum Hold Mode, except for the frequency band (9 kHz to 90 kHz and 110 kHz to 490 kHz) set to average detect function and peak detect function.

Notes:

1. The resolution bandwidth and video bandwidth of test receiver/spectrum analyzer is 200 Hz at frequency below 150 kHz.
2. The resolution bandwidth and video bandwidth of test receiver/spectrum analyzer is 9 kHz or 10 kHz at frequency (150 kHz to 30 MHz).
3. All modes of operation were investigated and the worst-case emissions are reported.

For Radiated emission above 30 MHz

- a. The EUT was placed on the top of a rotating table 0.8 meters above the ground at 3 meter chamber room for test. The table was rotated 360 degrees to determine the position of the highest radiation.
- b. The EUT was set 3 meters away from the interference-receiving antenna, which was mounted on the top of a variable-height antenna tower.
- c. The height of antenna is varied from one meter to four meters above the ground to determine the maximum value of the field strength. Both horizontal and vertical polarizations of the antenna are set to make the measurement.
- d. For each suspected emission, the EUT was arranged to its worst case and then the antenna was tuned to heights from 1 meter to 4 meters and the rotatable table was turned from 0 degrees to 360 degrees to find the maximum reading.
- e. The test-receiver system was set to quasi-peak detect function and specified bandwidth with maximum hold mode when the test frequency is below 1 GHz.

Notes:

1. The resolution bandwidth and video bandwidth of test receiver/spectrum analyzer is 120 kHz for Quasi-peak detection (QP) at frequency below 1 GHz.
2. All modes of operation were investigated and the worst-case emissions are reported.

6.10 Unwanted Emissions above 1 GHz

6.10.1 Test Setup

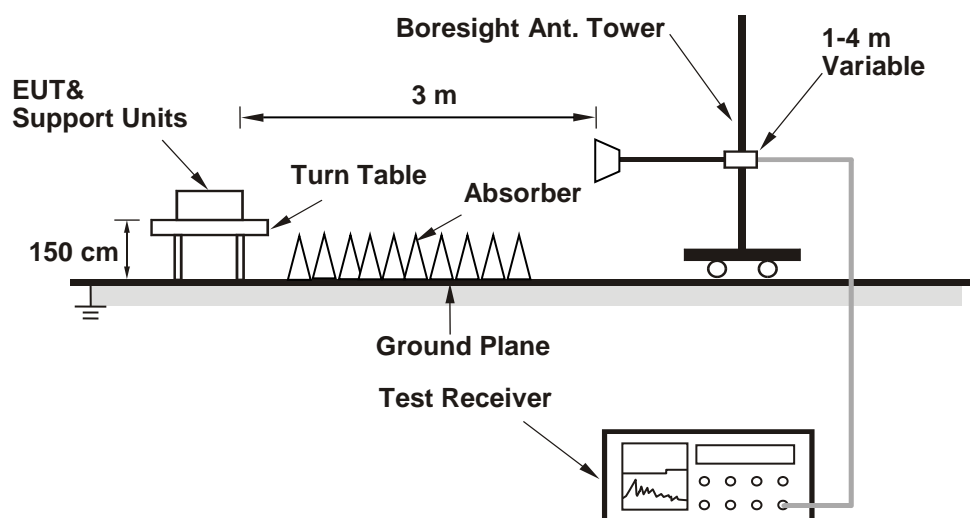

For the actual test configuration, please refer to the attached file (Test Setup Photo).

6.10.2 Test Procedure

- The EUT was placed on the top of a rotating table 1.5 meters above the ground at 3 meter chamber room for test. The table was rotated 360 degrees to determine the position of the highest radiation.
- The EUT was set 3 meters away from the interference-receiving antenna, which was mounted on the top of a variable-height antenna tower.
- The height of antenna is varied from one meter to four meters above the ground to determine the maximum value of the field strength. Both horizontal and vertical polarizations of the antenna are set to make the measurement.
- For each suspected emission, the EUT was arranged to its worst case and then the antenna was tuned to heights from 1 meter to 4 meters and the rotatable table was turned from 0 degrees to 360 degrees to find the maximum reading.
- The test-receiver system was set to peak and average detects function and specified bandwidth with maximum hold mode when the test frequency is above 1 GHz. If the peak reading value also meets average limit, measurement with the average detector is unnecessary.

Notes:

- The resolution bandwidth of test receiver/spectrum analyzer is 1 MHz and the video bandwidth is 3 MHz for Peak detection (PK) and Average detection (AV) at frequency above 1 GHz.
- For fundamental and harmonic signal measurement, the resolution bandwidth of test receiver/spectrum analyzer is 1 MHz and the video bandwidth is $\geq 1/T$ (Duty cycle $< 98\%$) or 10 Hz (Duty cycle $\geq 98\%$) for Average detection (AV) at frequency above 1 GHz.
- All modes of operation were investigated and the worst-case emissions are reported.

7 Test Results of Test Item

7.1 Maximum RF Output Power

Input Power:	120 Vac, 60 Hz	Environmental Conditions:	25°C, 60% RH	Tested By:	Ivan Tseng, Matthew Yang, Tim Chen, Jisyong Wang
--------------	----------------	---------------------------	--------------	------------	--

802.11a

Chan.	Chan. Freq. (MHz)	Field Strength (dBuV/m)	Correction Factor (dB)	EIRP (mW)	EIRP (dBm)	EIRP Limit (dBm)	Test Result
33	6115	111.05	-95.23	38.194	15.82	30	Pass
61	6255	111.02	-95.23	37.931	15.79	30	Pass
93	6415	111.02	-95.23	37.931	15.79	30	Pass
97	6435	110.96	-95.23	37.411	15.73	30	Pass
105	6475	110.87	-95.23	36.644	15.64	30	Pass
113	6515	110.97	-95.23	37.497	15.74	30	Pass
117	6535	110.89	-95.23	36.813	15.66	30	Pass
149	6695	110.90	-95.23	36.898	15.67	30	Pass
181	6855	110.90	-95.23	36.898	15.67	30	Pass
185	6875	110.97	-95.23	37.497	15.74	30	Pass
209	6995	110.87	-95.23	36.644	15.64	30	Pass
229	7095	110.82	-95.23	36.224	15.59	30	Pass
233	7115	111.03	-95.23	38.019	15.80	30	Pass

Spectrum Plot of Maximum Value

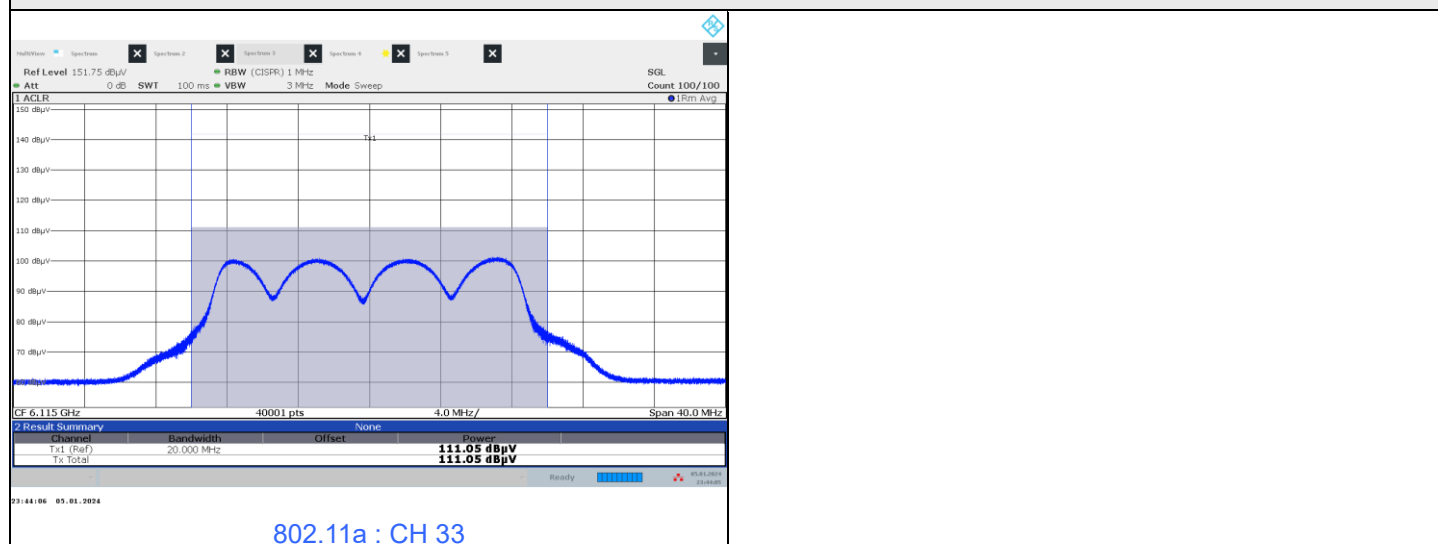

Beamforming (2T1S)

802.11be (EHT20) Beamforming

Chan.	Chan. Freq. (MHz)	Field Strength (dBuV/m)	Correction Factor (dB)	EIRP (mW)	EIRP (dBm)	EIRP Limit (dBm)	Test Result
33	6115	113.51	-95.23	67.298	18.28	30	Pass
61	6255	113.39	-95.23	65.464	18.16	30	Pass
93	6415	113.63	-95.23	69.183	18.40	30	Pass
97	6435	113.25	-95.23	63.387	18.02	30	Pass
105	6475	113.39	-95.23	65.464	18.16	30	Pass
113	6515	113.47	-95.23	66.681	18.24	30	Pass
117	6535	113.57	-95.23	68.234	18.34	30	Pass
149	6695	113.71	-95.23	70.469	18.48	30	Pass
181	6855	113.37	-95.23	65.163	18.14	30	Pass
185	6875	113.57	-95.23	68.234	18.34	30	Pass
209	6995	113.47	-95.23	66.681	18.24	30	Pass
229	7095	113.49	-95.23	66.988	18.26	30	Pass
233	7115	99.07	-95.23	2.421	3.84	30	Pass

802.11be (EHT40) Beamforming

Chan.	Chan. Freq. (MHz)	Field Strength (dBuV/m)	Correction Factor (dB)	EIRP (mW)	EIRP (dBm)	EIRP Limit (dBm)	Test Result
35	6125	115.94	-95.23	117.761	20.71	30	Pass
59	6245	115.95	-95.23	118.032	20.72	30	Pass
91	6405	115.90	-95.23	116.681	20.67	30	Pass
99	6445	115.94	-95.23	117.761	20.71	30	Pass
107	6485	116.16	-95.23	123.88	20.93	30	Pass
115	6525	115.96	-95.23	118.304	20.73	30	Pass
123	6565	116.04	-95.23	120.504	20.81	30	Pass
155	6725	116.01	-95.23	119.674	20.78	30	Pass
179	6845	116.18	-95.23	124.451	20.95	30	Pass
187	6885	116.00	-95.23	119.399	20.77	30	Pass
211	7005	116.00	-95.23	119.399	20.77	30	Pass
227	7085	116.02	-95.23	119.95	20.79	30	Pass

802.11be (EHT80) Beamforming

Chan.	Chan. Freq. (MHz)	Field Strength (dBuV/m)	Correction Factor (dB)	EIRP (mW)	EIRP (dBm)	EIRP Limit (dBm)	Test Result
39	6145	119.10	-95.23	243.781	23.87	30	Pass
55	6225	119.01	-95.23	238.781	23.78	30	Pass
87	6385	119.01	-95.23	238.781	23.78	30	Pass
103	6465	119.20	-95.23	249.459	23.97	30	Pass
119	6545	118.98	-95.23	237.137	23.75	30	Pass
135	6625	119.22	-95.23	250.611	23.99	30	Pass
151	6705	119.17	-95.23	247.742	23.94	30	Pass
167	6785	119.00	-95.23	238.232	23.77	30	Pass
183	6865	119.04	-95.23	240.436	23.81	30	Pass
199	6945	119.12	-95.23	244.906	23.89	30	Pass
215	7025	119.02	-95.23	239.332	23.79	30	Pass

802.11be (EHT160) Beamforming

Chan.	Chan. Freq. (MHz)	Field Strength (dBuV/m)	Correction Factor (dB)	EIRP (mW)	EIRP (dBm)	EIRP Limit (dBm)	Test Result
47	6185	122.18	-95.23	495.45	26.95	30	Pass
79	6345	122.05	-95.23	480.839	26.82	30	Pass
111	6505	122.03	-95.23	478.63	26.80	30	Pass
143	6665	121.93	-95.23	467.735	26.70	30	Pass
175	6825	122.17	-95.23	494.311	26.94	30	Pass
207	6985	122.08	-95.23	484.172	26.85	30	Pass

802.11be (EHT320) Beamforming

Chan.	Chan. Freq. (MHz)	Field Strength (dBuV/m)	Correction Factor (dB)	EIRP (mW)	EIRP (dBm)	EIRP Limit (dBm)	Test Result
63	6265	124.49	-95.23	843.335	29.26	30	Pass
95	6425	124.35	-95.23	816.582	29.12	30	Pass
127	6585	124.31	-95.23	809.096	29.08	30	Pass
159	6745	124.50	-95.23	845.279	29.27	30	Pass
191	6905	124.57	-95.23	859.014	29.34	30	Pass

Spectrum Plot of Maximum Value

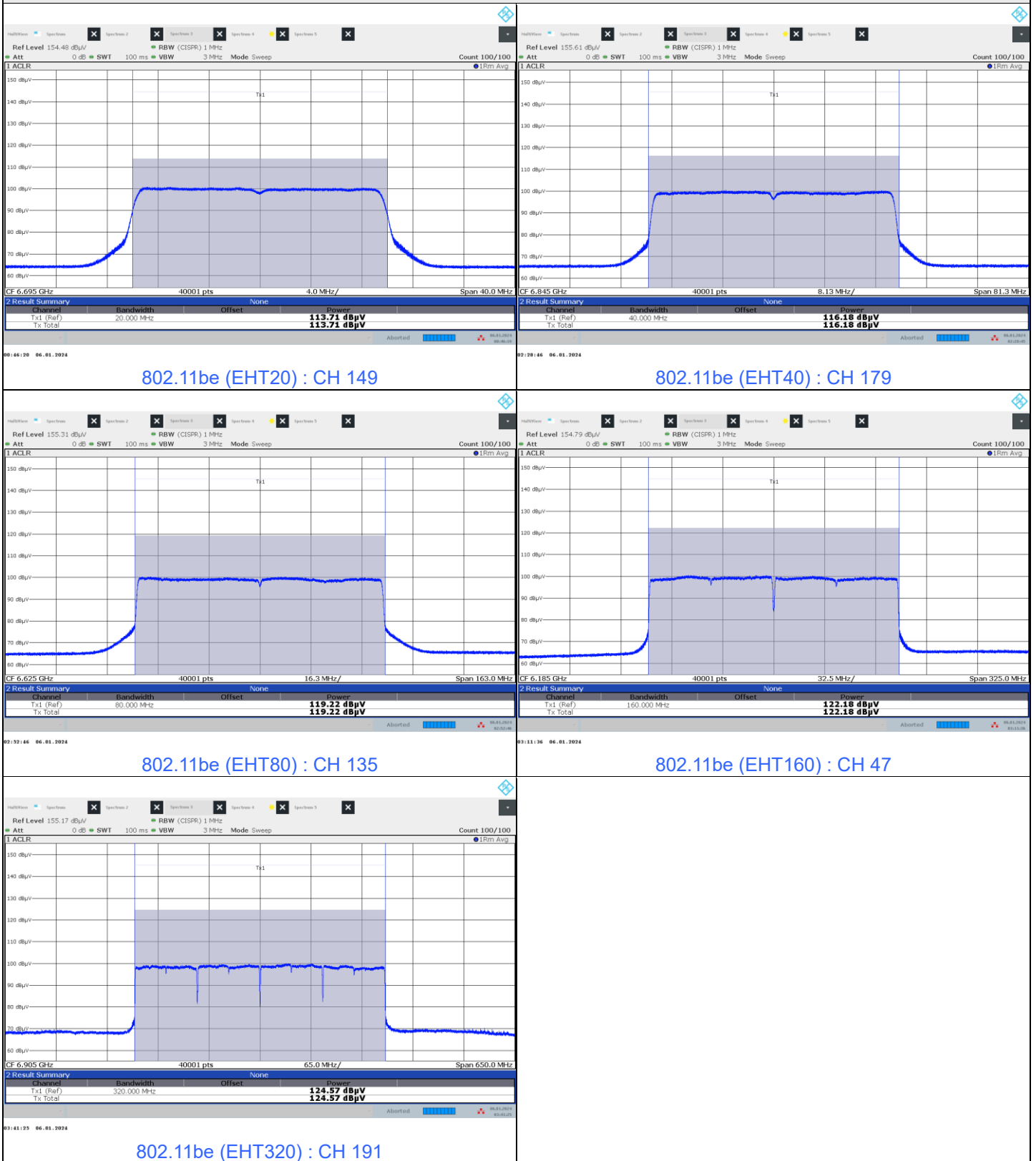

802.11be (EHT20) : CH 149

802.11be (EHT40) : CH 179

802.11be (EHT80) : CH 135

802.11be (EHT160) : CH 47

802.11be (EHT320) : CH 191

Beamforming (2T2S)

802.11be (EHT20) Beamforming

Chan.	Chan. Freq. (MHz)	Field Strength (dBuV/m)	Correction Factor (dB)	EIRP (mW)	EIRP (dBm)	EIRP Limit (dBm)	Test Result
33	6115	113.27	-95.23	63.68	18.04	30	Pass
61	6255	113.15	-95.23	61.944	17.92	30	Pass
93	6415	113.31	-95.23	64.269	18.08	30	Pass
97	6435	113.19	-95.23	62.517	17.96	30	Pass
105	6475	113.22	-95.23	62.951	17.99	30	Pass
113	6515	113.16	-95.23	62.087	17.93	30	Pass
117	6535	113.38	-95.23	65.313	18.15	30	Pass
149	6695	113.41	-95.23	65.766	18.18	30	Pass
181	6855	113.18	-95.23	62.373	17.95	30	Pass
185	6875	113.08	-95.23	60.954	17.85	30	Pass
209	6995	113.21	-95.23	62.806	17.98	30	Pass
229	7095	113.30	-95.23	64.121	18.07	30	Pass
233	7115	97.45	-95.23	1.667	2.22	30	Pass

802.11be (EHT40) Beamforming

Chan.	Chan. Freq. (MHz)	Field Strength (dBuV/m)	Correction Factor (dB)	EIRP (mW)	EIRP (dBm)	EIRP Limit (dBm)	Test Result
35	6125	116.11	-95.23	122.462	20.88	30	Pass
59	6245	115.76	-95.23	112.98	20.53	30	Pass
91	6405	115.90	-95.23	116.681	20.67	30	Pass
99	6445	115.97	-95.23	118.577	20.74	30	Pass
107	6485	115.97	-95.23	118.577	20.74	30	Pass
115	6525	115.88	-95.23	116.145	20.65	30	Pass
123	6565	115.92	-95.23	117.22	20.69	30	Pass
155	6725	115.74	-95.23	112.46	20.51	30	Pass
179	6845	115.85	-95.23	115.345	20.62	30	Pass
187	6885	115.89	-95.23	116.413	20.66	30	Pass
211	7005	116.07	-95.23	121.339	20.84	30	Pass
227	7085	115.81	-95.23	114.288	20.58	30	Pass

802.11be (EHT80) Beamforming

Chan.	Chan. Freq. (MHz)	Field Strength (dBuV/m)	Correction Factor (dB)	EIRP (mW)	EIRP (dBm)	EIRP Limit (dBm)	Test Result
39	6145	119.06	-95.23	241.546	23.83	30	Pass
55	6225	119.01	-95.23	238.781	23.78	30	Pass
87	6385	119.01	-95.23	238.781	23.78	30	Pass
103	6465	118.97	-95.23	236.592	23.74	30	Pass
119	6545	119.12	-95.23	244.906	23.89	30	Pass
135	6625	118.93	-95.23	234.423	23.70	30	Pass
151	6705	118.95	-95.23	235.505	23.72	30	Pass
167	6785	118.83	-95.23	229.087	23.60	30	Pass
183	6865	118.91	-95.23	233.346	23.68	30	Pass
199	6945	119.10	-95.23	243.781	23.87	30	Pass
215	7025	118.86	-95.23	230.675	23.63	30	Pass

802.11be (EHT160) Beamforming

Chan.	Chan. Freq. (MHz)	Field Strength (dBuV/m)	Correction Factor (dB)	EIRP (mW)	EIRP (dBm)	EIRP Limit (dBm)	Test Result
47	6185	121.88	-95.23	462.381	26.65	30	Pass
79	6345	122.10	-95.23	486.407	26.87	30	Pass
111	6505	121.97	-95.23	472.063	26.74	30	Pass
143	6665	121.76	-95.23	449.78	26.53	30	Pass
175	6825	122.00	-95.23	475.335	26.77	30	Pass
207	6985	122.14	-95.23	490.908	26.91	30	Pass

802.11be (EHT320) Beamforming

Chan.	Chan. Freq. (MHz)	Field Strength (dBuV/m)	Correction Factor (dB)	EIRP (mW)	EIRP (dBm)	EIRP Limit (dBm)	Test Result
63	6265	124.99	-95.23	946.237	29.76	30	Pass
95	6425	125.17	-95.23	986.279	29.94	30	Pass
127	6585	124.98	-95.23	944.061	29.75	30	Pass
159	6745	124.92	-95.23	931.108	29.69	30	Pass
191	6905	124.90	-95.23	926.83	29.67	30	Pass

Spectrum Plot of Maximum Value

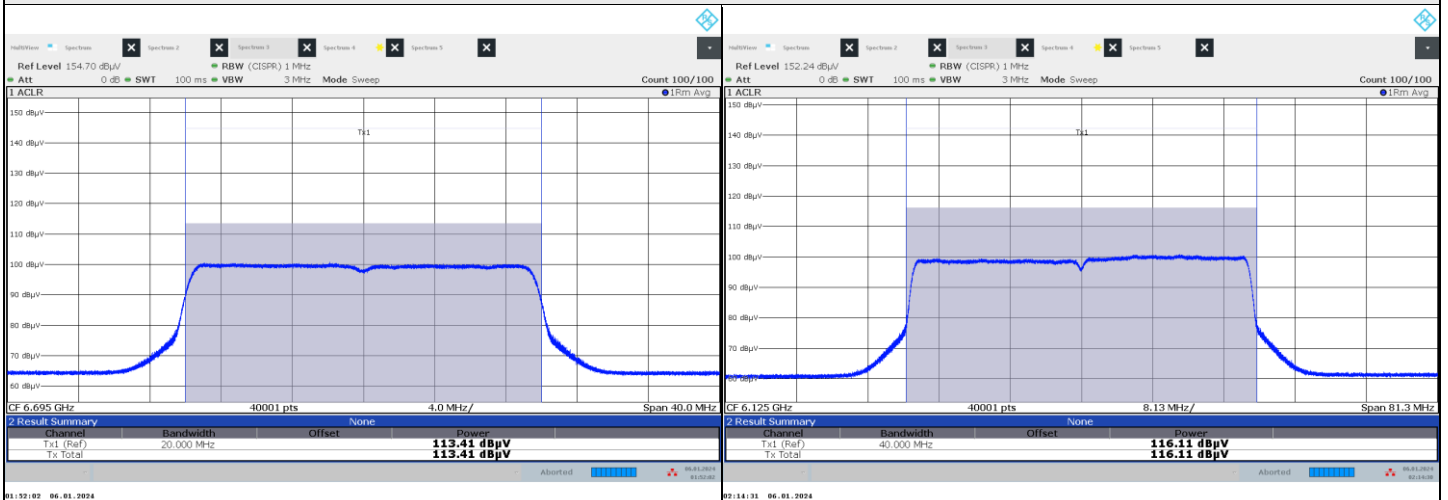

802.11be (EHT20) : CH 149

802.11be (EHT40) : CH 35

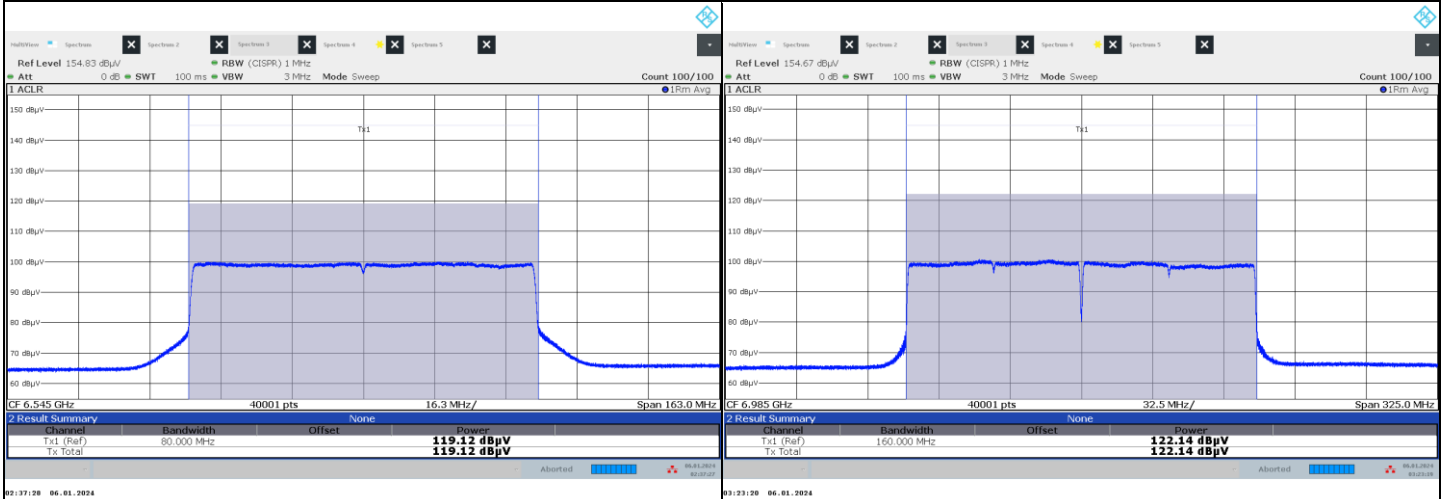

802.11be (EHT80) : CH 119

802.11be (EHT160) : CH 207

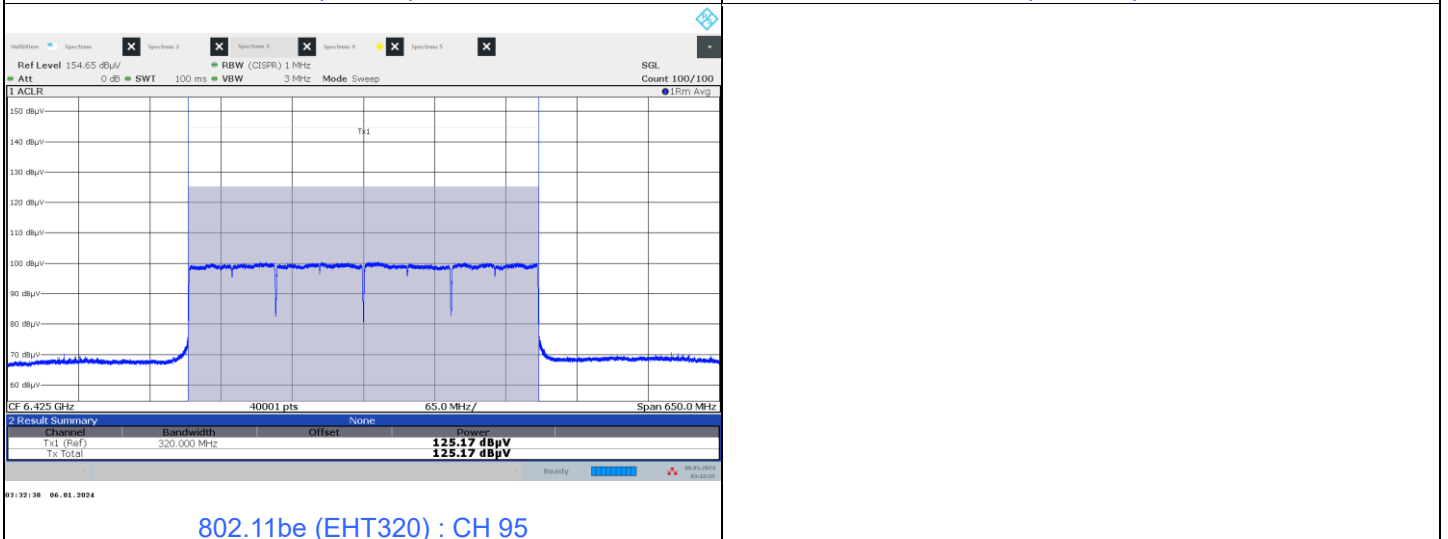

802.11be (EHT320) : CH 95

7.2 Maximum Power Spectral Density

Input Power:	120 Vac, 60 Hz	Environmental Conditions:	25°C, 60% RH	Tested By:	Ivan Tseng, Matthew Yang, Tim Chen, Jisyong Wang
--------------	----------------	---------------------------	--------------	------------	--

802.11a

Chan.	Chan. Freq. (MHz)	Field Strength (dBuV/m)	Correction Factor (dB)	EIRP PSD (dBm/MHz)	EIRP PSD Limit (dBm/MHz)	Test Result
33	6115	100.21	-95.23	4.98	5	Pass
61	6255	100.16	-95.23	4.93	5	Pass
93	6415	100.15	-95.23	4.92	5	Pass
97	6435	100.09	-95.23	4.86	5	Pass
105	6475	100.01	-95.23	4.78	5	Pass
113	6515	100.02	-95.23	4.79	5	Pass
117	6535	100.14	-95.23	4.91	5	Pass
149	6695	100.09	-95.23	4.86	5	Pass
181	6855	100.16	-95.23	4.93	5	Pass
185	6875	100.14	-95.23	4.91	5	Pass
209	6995	100.16	-95.23	4.93	5	Pass
229	7095	100.19	-95.23	4.96	5	Pass
233	7115	100.05	-95.23	4.82	5	Pass

Spectrum Plot of Maximum Value

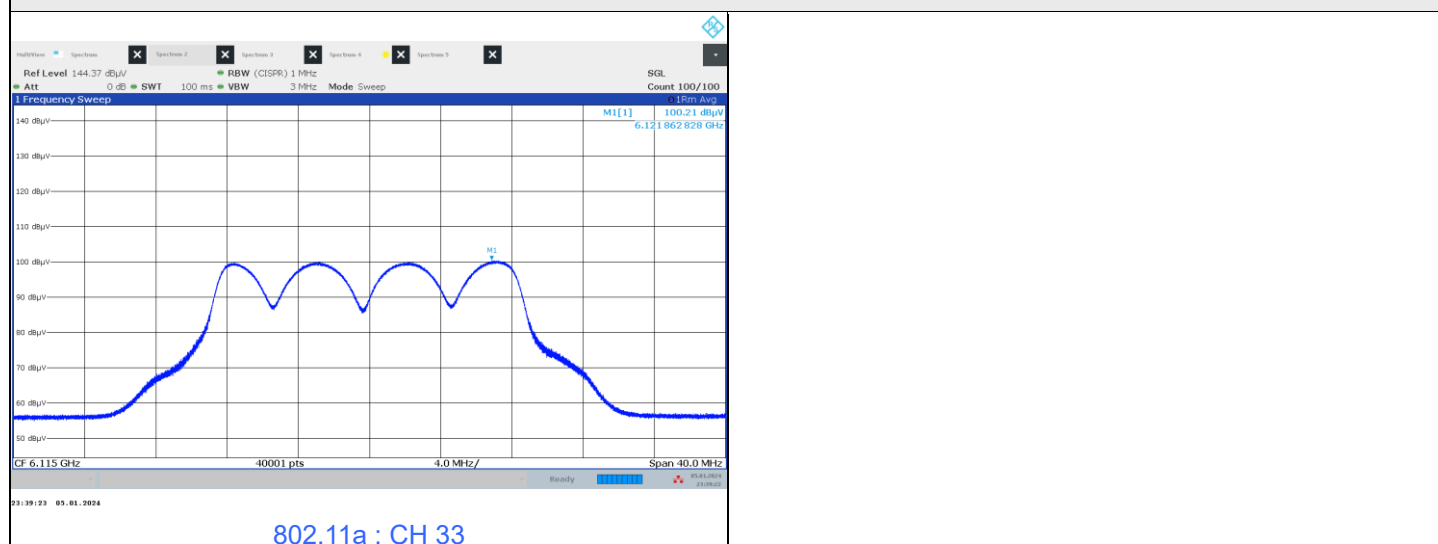

Beamforming (2T1S)

802.11be (EHT20) Beamforming

Chan.	Chan. Freq. (MHz)	Field Strength (dBuV/m)	Correction Factor (dB)	EIRP PSD (dBm/MHz)	EIRP PSD Limit (dBm/MHz)	Test Result
33	6115	100.02	-95.23	4.79	5	Pass
61	6255	100.03	-95.23	4.80	5	Pass
93	6415	100.07	-95.23	4.84	5	Pass
97	6435	100.02	-95.23	4.79	5	Pass
105	6475	100.01	-95.23	4.78	5	Pass
113	6515	100.18	-95.23	4.95	5	Pass
117	6535	100.17	-95.23	4.94	5	Pass
149	6695	100.20	-95.23	4.97	5	Pass
181	6855	100.01	-95.23	4.78	5	Pass
185	6875	100.16	-95.23	4.93	5	Pass
209	6995	100.00	-95.23	4.77	5	Pass
229	7095	100.06	-95.23	4.83	5	Pass
233	7115	86.07	-95.23	-9.16	5	Pass

802.11be (EHT40) Beamforming

Chan.	Chan. Freq. (MHz)	Field Strength (dBuV/m)	Correction Factor (dB)	EIRP PSD (dBm/MHz)	EIRP PSD Limit (dBm/MHz)	Test Result
35	6125	100.07	-95.23	4.84	5	Pass
59	6245	100.19	-95.23	4.96	5	Pass
91	6405	100.17	-95.23	4.94	5	Pass
99	6445	100.02	-95.23	4.79	5	Pass
107	6485	100.02	-95.23	4.79	5	Pass
115	6525	100.00	-95.23	4.77	5	Pass
123	6565	100.01	-95.23	4.78	5	Pass
155	6725	100.02	-95.23	4.79	5	Pass
179	6845	100.20	-95.23	4.97	5	Pass
187	6885	100.14	-95.23	4.91	5	Pass
211	7005	100.00	-95.23	4.77	5	Pass
227	7085	100.13	-95.23	4.90	5	Pass

802.11be (EHT80) Beamforming

Chan.	Chan. Freq. (MHz)	Field Strength (dBuV/m)	Correction Factor (dB)	EIRP PSD (dBm/MHz)	EIRP PSD Limit (dBm/MHz)	Test Result
39	6145	100.05	-95.23	4.82	5	Pass
55	6225	100.10	-95.23	4.87	5	Pass
87	6385	100.09	-95.23	4.86	5	Pass
103	6465	100.03	-95.23	4.80	5	Pass
119	6545	100.16	-95.23	4.93	5	Pass
135	6625	100.21	-95.23	4.98	5	Pass
151	6705	100.19	-95.23	4.96	5	Pass
167	6785	100.14	-95.23	4.91	5	Pass
183	6865	100.07	-95.23	4.84	5	Pass
199	6945	100.01	-95.23	4.78	5	Pass
215	7025	100.15	-95.23	4.92	5	Pass

802.11be (EHT160) Beamforming

Chan.	Chan. Freq. (MHz)	Field Strength (dBuV/m)	Correction Factor (dB)	EIRP PSD (dBm/MHz)	EIRP PSD Limit (dBm/MHz)	Test Result
47	6185	100.19	-95.23	4.96	5	Pass
79	6345	99.99	-95.23	4.76	5	Pass
111	6505	100.12	-95.23	4.89	5	Pass
143	6665	100.18	-95.23	4.95	5	Pass
175	6825	100.08	-95.23	4.85	5	Pass
207	6985	100.02	-95.23	4.79	5	Pass

802.11be (EHT320) Beamforming

Chan.	Chan. Freq. (MHz)	Field Strength (dBuV/m)	Correction Factor (dB)	EIRP PSD (dBm/MHz)	EIRP PSD Limit (dBm/MHz)	Test Result
63	6265	99.09	-95.23	3.86	5	Pass
95	6425	99.14	-95.23	3.91	5	Pass
127	6585	98.97	-95.23	3.74	5	Pass
159	6745	99.09	-95.23	3.86	5	Pass
191	6905	99.16	-95.23	3.93	5	Pass



Spectrum Plot of Maximum Value

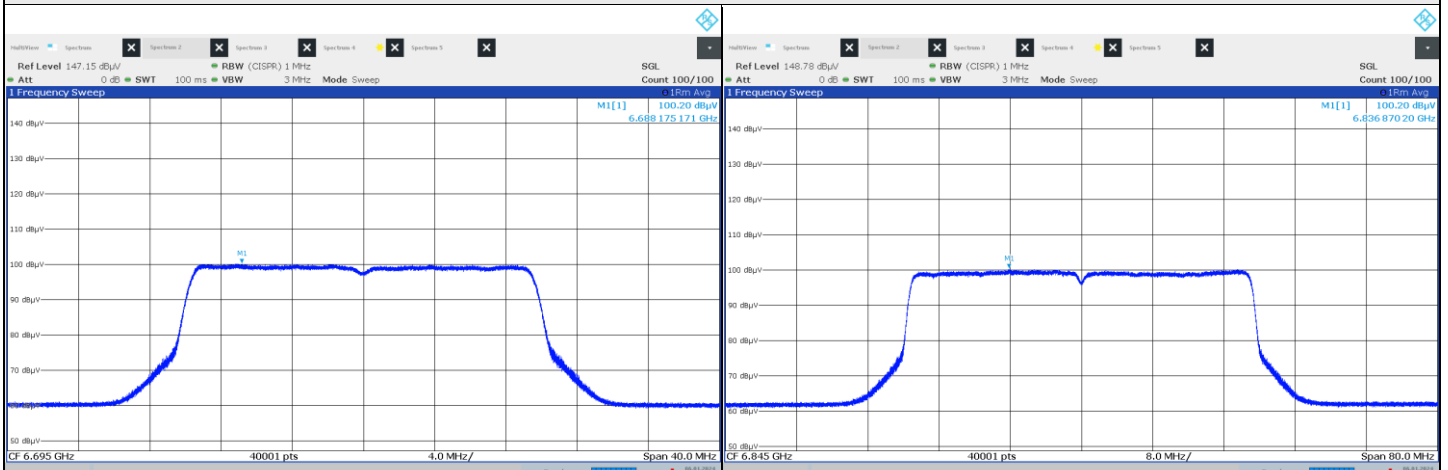

802.11be (EHT20) : CH 149

802.11be (EHT40) : CH 179

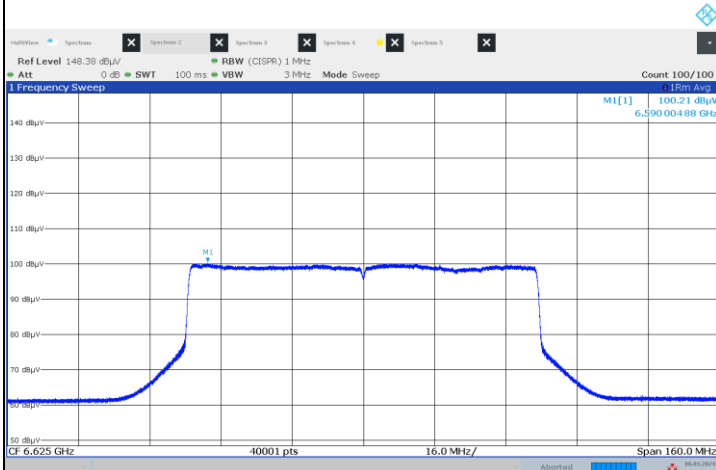

802.11be (EHT80) : CH 135

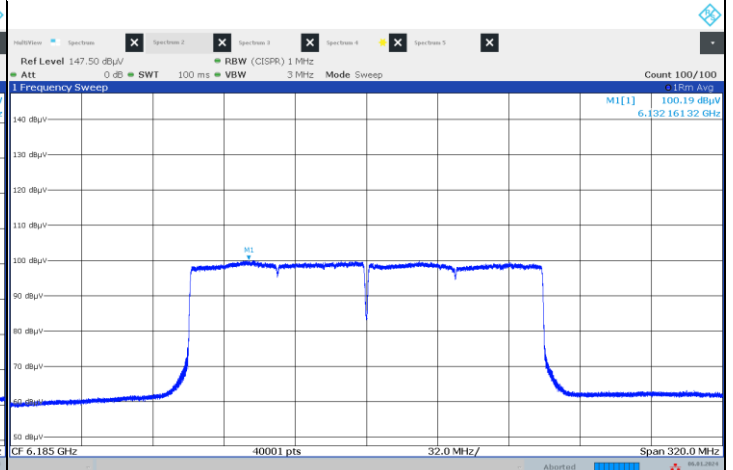

802.11be (EHT160) : CH 47

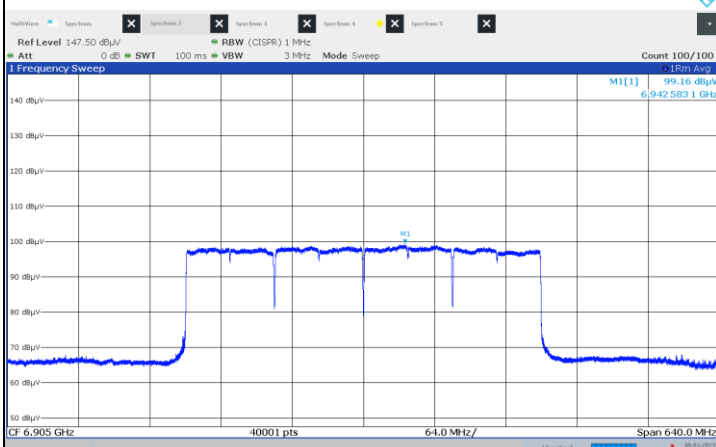

802.11be (EHT320) : CH 191

Beamforming (2T2S)

802.11be (EHT20) Beamforming

Chan.	Chan. Freq. (MHz)	Field Strength (dBuV/m)	Correction Factor (dB)	EIRP PSD (dBm/MHz)	EIRP PSD Limit (dBm/MHz)	Test Result
33	6115	100.08	-95.23	4.85	5	Pass
61	6255	100.18	-95.23	4.95	5	Pass
93	6415	100.09	-95.23	4.86	5	Pass
97	6435	100.18	-95.23	4.95	5	Pass
105	6475	100.16	-95.23	4.93	5	Pass
113	6515	100.17	-95.23	4.94	5	Pass
117	6535	100.13	-95.23	4.90	5	Pass
149	6695	100.20	-95.23	4.97	5	Pass
181	6855	100.09	-95.23	4.86	5	Pass
185	6875	100.07	-95.23	4.84	5	Pass
209	6995	100.14	-95.23	4.91	5	Pass
229	7095	100.15	-95.23	4.92	5	Pass
233	7115	85.90	-95.23	-9.33	5	Pass

802.11be (EHT40) Beamforming

Chan.	Chan. Freq. (MHz)	Field Strength (dBuV/m)	Correction Factor (dB)	EIRP PSD (dBm/MHz)	EIRP PSD Limit (dBm/MHz)	Test Result
35	6125	100.20	-95.23	4.97	5	Pass
59	6245	100.17	-95.23	4.94	5	Pass
91	6405	100.18	-95.23	4.95	5	Pass
99	6445	100.19	-95.23	4.96	5	Pass
107	6485	100.15	-95.23	4.92	5	Pass
115	6525	100.14	-95.23	4.91	5	Pass
123	6565	100.16	-95.23	4.93	5	Pass
155	6725	100.07	-95.23	4.84	5	Pass
179	6845	100.07	-95.23	4.84	5	Pass
187	6885	100.18	-95.23	4.95	5	Pass
211	7005	100.13	-95.23	4.90	5	Pass
227	7085	100.11	-95.23	4.88	5	Pass

802.11be (EHT80) Beamforming

Chan.	Chan. Freq. (MHz)	Field Strength (dBuV/m)	Correction Factor (dB)	EIRP PSD (dBm/MHz)	EIRP PSD Limit (dBm/MHz)	Test Result
39	6145	100.15	-95.23	4.92	5	Pass
55	6225	100.08	-95.23	4.85	5	Pass
87	6385	100.08	-95.23	4.85	5	Pass
103	6465	100.17	-95.23	4.94	5	Pass
119	6545	100.21	-95.23	4.98	5	Pass
135	6625	100.11	-95.23	4.88	5	Pass
151	6705	100.13	-95.23	4.90	5	Pass
167	6785	100.19	-95.23	4.96	5	Pass
183	6865	100.13	-95.23	4.90	5	Pass
199	6945	100.16	-95.23	4.93	5	Pass
215	7025	100.08	-95.23	4.85	5	Pass

802.11be (EHT160) Beamforming

Chan.	Chan. Freq. (MHz)	Field Strength (dBuV/m)	Correction Factor (dB)	EIRP PSD (dBm/MHz)	EIRP PSD Limit (dBm/MHz)	Test Result
47	6185	100.15	-95.23	4.92	5	Pass
79	6345	100.12	-95.23	4.89	5	Pass
111	6505	100.09	-95.23	4.86	5	Pass
143	6665	100.07	-95.23	4.84	5	Pass
175	6825	100.08	-95.23	4.85	5	Pass
207	6985	100.17	-95.23	4.94	5	Pass

802.11be (EHT320) Beamforming

Chan.	Chan. Freq. (MHz)	Field Strength (dBuV/m)	Correction Factor (dB)	EIRP PSD (dBm/MHz)	EIRP PSD Limit (dBm/MHz)	Test Result
63	6265	100.15	-95.23	4.92	5	Pass
95	6425	100.18	-95.23	4.95	5	Pass
127	6585	100.13	-95.23	4.90	5	Pass
159	6745	100.17	-95.23	4.94	5	Pass
191	6905	99.08	-95.23	3.85	5	Pass

Spectrum Plot of Maximum Value

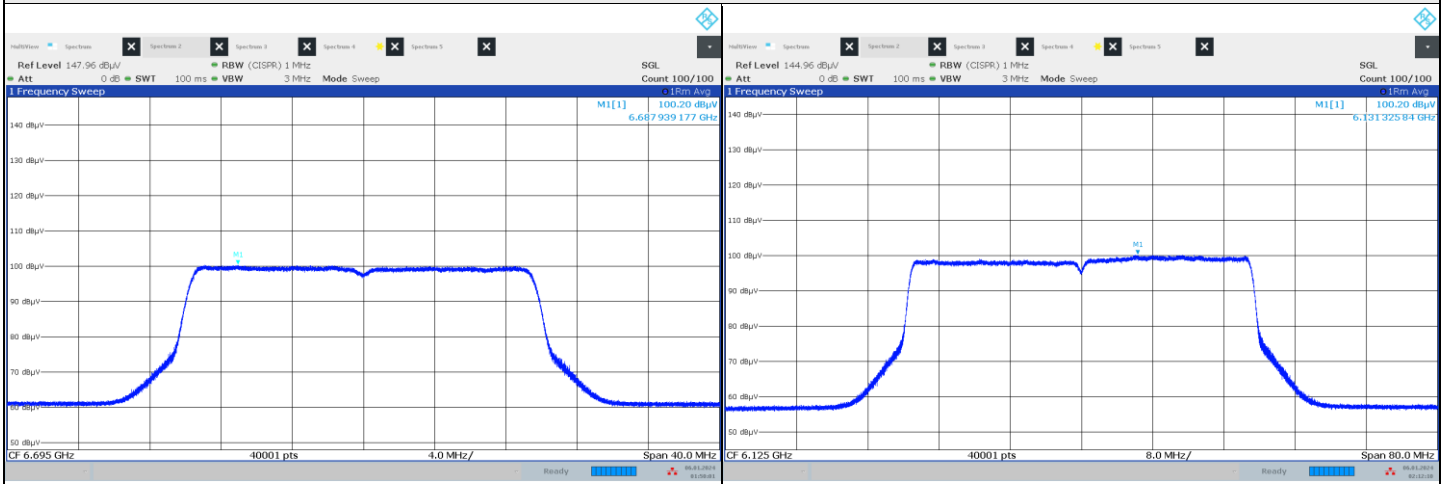

802.11be (EHT20) : CH 149

802.11be (EHT40) : CH 35

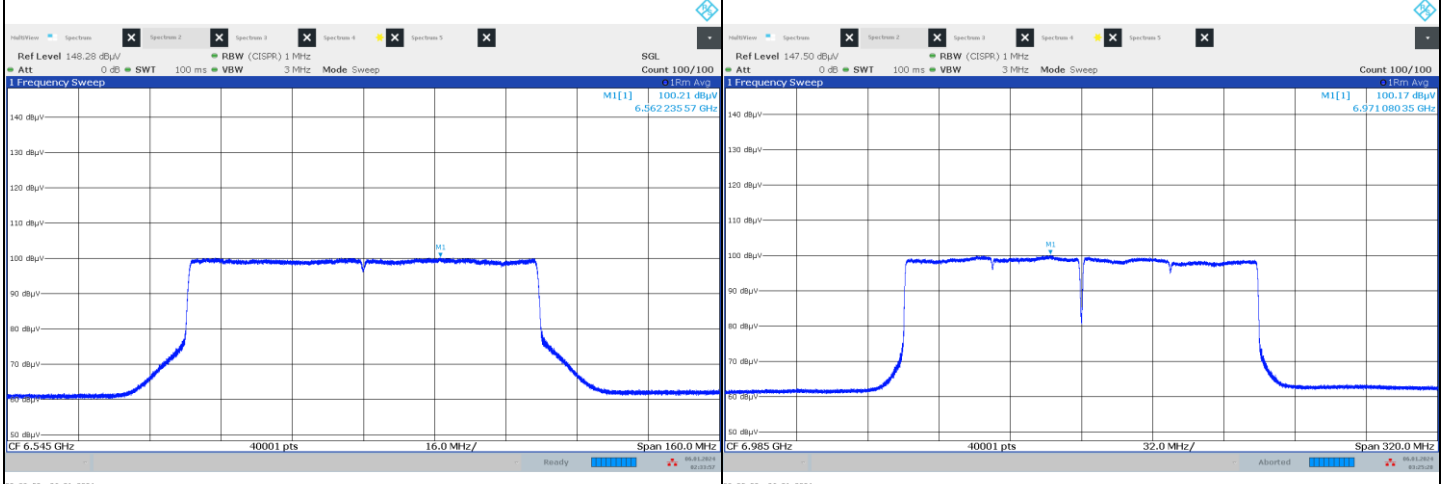

802.11be (EHT80) : CH 119

802.11be (EHT160) : CH 207

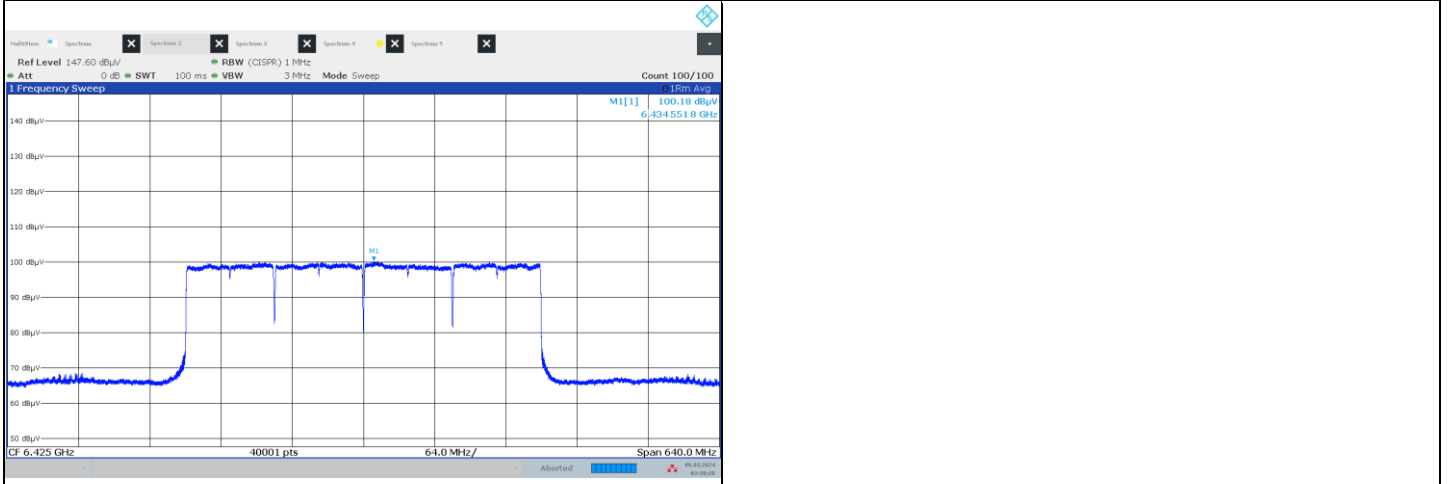

802.11be (EHT320) : CH 95

7.3 Emission Bandwidth

Input Power:	120 Vac, 60 Hz	Environmental Conditions:	25°C, 60% RH	Tested By:	Ivan Tseng, Matthew Yang, Tim Chen, Jisyong Wang
--------------	----------------	---------------------------	--------------	------------	--

802.11a

Channel	Frequency (MHz)	26dB Bandwidth (MHz)		Maximum Limit (MHz)	Test Result
		Chain 0	Chain 1		
33	6115	22.59	22.33	320	Pass
61	6255	22.86	22.49	320	Pass
93	6415	22.55	22.57	320	Pass
97	6435	22.66	23.32	320	Pass
105	6475	22.68	22.75	320	Pass
113	6515	22.59	22.48	320	Pass
117	6535	22.70	23.02	320	Pass
149	6695	22.49	22.80	320	Pass
181	6855	22.86	23.10	320	Pass
185	6875	22.67	23.21	320	Pass
209	6995	22.63	23.38	320	Pass
229	7095	22.73	23.25	320	Pass
233	7115	22.62	23.42	320	Pass

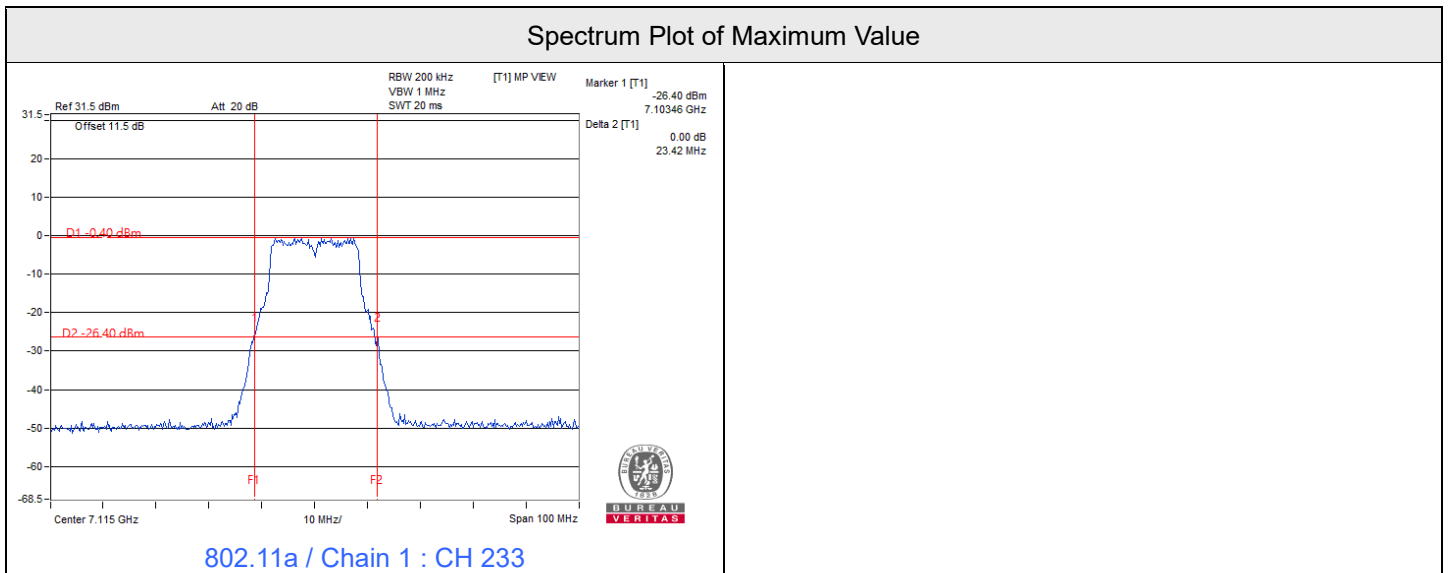

Beamforming (2T1S)

802.11be (EHT20)

Channel	Frequency (MHz)	26dB Bandwidth (MHz)		Maximum Limit (MHz)	Test Result
		Chain 0	Chain 1		
33	6115	23.40	23.62	320	Pass
61	6255	23.48	23.93	320	Pass
93	6415	23.48	23.85	320	Pass
97	6435	23.52	23.45	320	Pass
105	6475	23.39	23.73	320	Pass
113	6515	23.00	23.89	320	Pass
117	6535	23.47	23.91	320	Pass
149	6695	23.41	23.83	320	Pass
181	6855	23.54	23.90	320	Pass
185	6875	23.55	23.44	320	Pass
209	6995	23.48	23.64	320	Pass
229	7095	23.36	23.86	320	Pass
233	7115	23.58	23.83	320	Pass

802.11be (EHT40)

Channel	Frequency (MHz)	26dB Bandwidth (MHz)		Maximum Limit (MHz)	Test Result
		Chain 0	Chain 1		
35	6125	45.61	44.73	320	Pass
59	6245	45.24	45.19	320	Pass
91	6405	45.16	45.38	320	Pass
99	6445	44.94	44.94	320	Pass
107	6485	45.45	44.43	320	Pass
115	6525	45.60	44.36	320	Pass
123	6565	45.26	45.21	320	Pass
155	6725	45.35	45.16	320	Pass
179	6845	44.80	44.73	320	Pass
187	6885	44.88	44.48	320	Pass
211	7005	45.49	44.55	320	Pass
227	7085	44.92	44.83	320	Pass

802.11be (EHT80)

Channel	Frequency (MHz)	26dB Bandwidth (MHz)		Maximum Limit (MHz)	Test Result
		Chain 0	Chain 1		
39	6145	91.04	90.97	320	Pass
55	6225	90.84	90.88	320	Pass
87	6385	90.76	90.76	320	Pass
103	6465	90.65	90.16	320	Pass
119	6545	90.99	92.41	320	Pass
135	6625	90.03	90.46	320	Pass
151	6705	90.97	90.02	320	Pass
167	6785	90.98	91.70	320	Pass
183	6865	90.98	91.60	320	Pass
199	6945	90.48	91.12	320	Pass
215	7025	90.92	91.00	320	Pass

802.11be (EHT160)

Channel	Frequency (MHz)	26dB Bandwidth (MHz)		Maximum Limit (MHz)	Test Result
		Chain 0	Chain 1		
47	6185	175.95	174.92	320	Pass
79	6345	175.73	174.10	320	Pass
111	6505	177.90	175.23	320	Pass
143	6665	177.57	173.28	320	Pass
175	6825	176.50	174.45	320	Pass
207	6985	177.01	173.07	320	Pass

802.11be (EHT320)

Channel	Frequency (MHz)	26dB Bandwidth (MHz)		Maximum Limit (MHz)	Test Result
		Chain 0	Chain 1		
63	6265	571.85	582.76	320	Note
95	6425	342.44	340.26	320	Note
127	6585	343.25	344.36	320	Note
159	6745	344.81	340.33	320	Note
191	6905	343.09	341.11	320	Note

Note: Please refer to 99% OBW measurement test results for Wi-Fi 320 MHz BW mode.



Spectrum Plot of Maximum Value

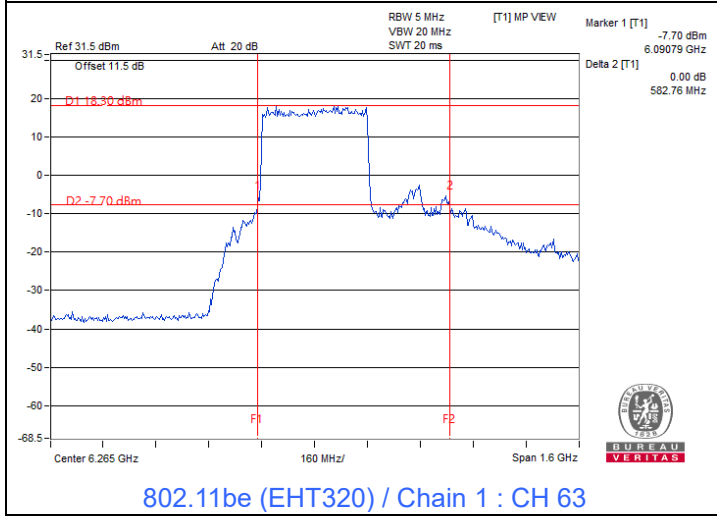
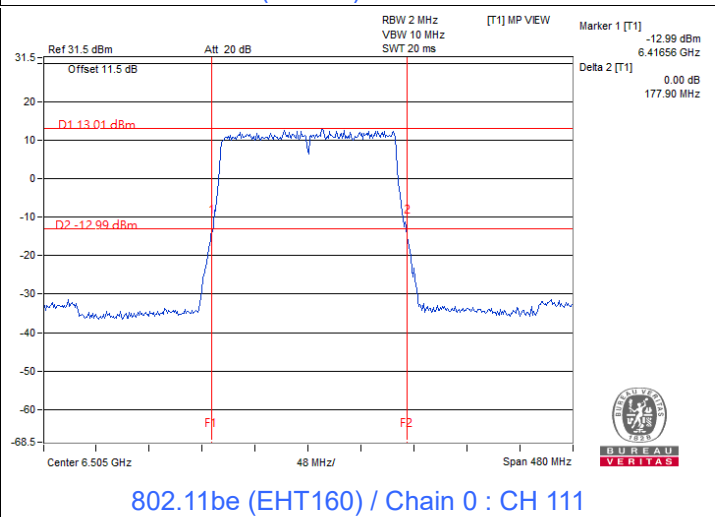
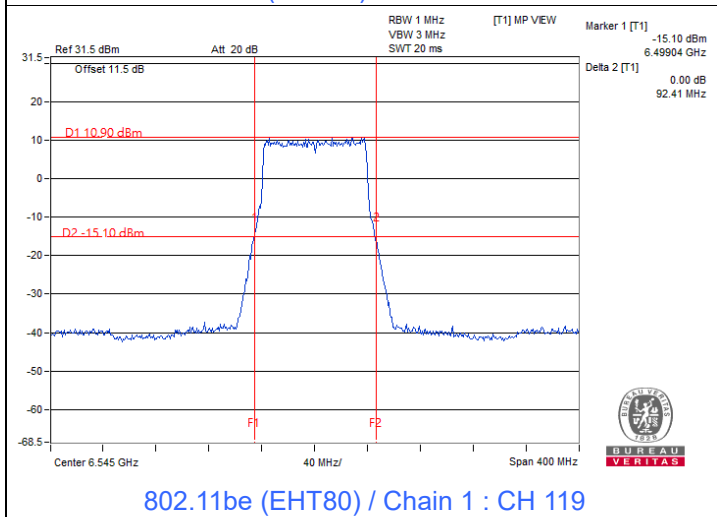
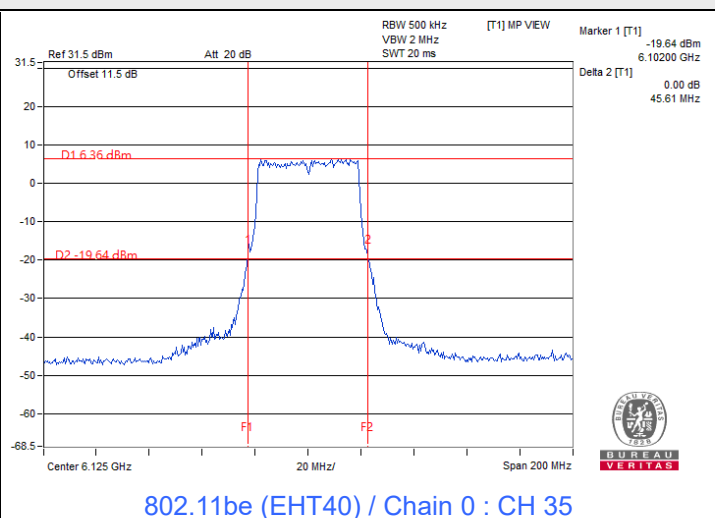
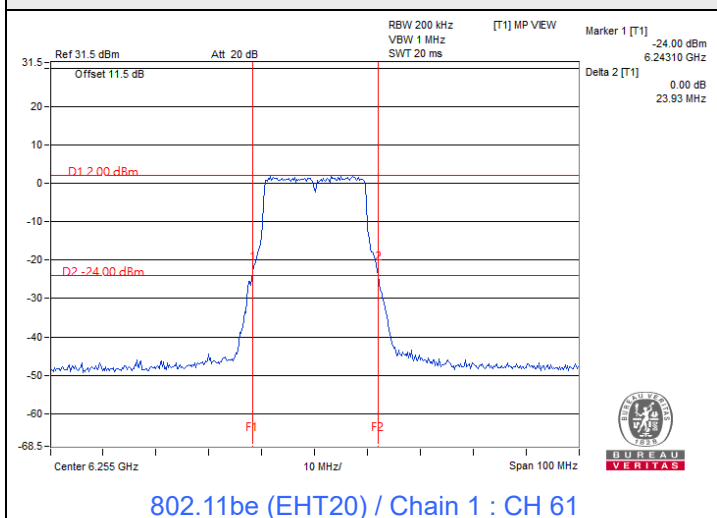

Beamforming (2T2S)

802.11be (EHT20)

Channel	Frequency (MHz)	26dB Bandwidth (MHz)		Maximum Limit (MHz)	Test Result
		Chain 0	Chain 1		
33	6115	23.05	23.68	320	Pass
61	6255	23.57	23.76	320	Pass
93	6415	23.55	23.80	320	Pass
97	6435	23.36	23.45	320	Pass
105	6475	23.14	23.70	320	Pass
113	6515	23.33	23.52	320	Pass
117	6535	23.52	23.81	320	Pass
149	6695	23.48	23.82	320	Pass
181	6855	23.21	24.06	320	Pass
185	6875	23.04	23.70	320	Pass
209	6995	23.59	23.82	320	Pass
229	7095	23.42	23.62	320	Pass
233	7115	23.12	23.60	320	Pass

802.11be (EHT40)

Channel	Frequency (MHz)	26dB Bandwidth (MHz)		Maximum Limit (MHz)	Test Result
		Chain 0	Chain 1		
35	6125	45.04	44.45	320	Pass
59	6245	44.73	44.34	320	Pass
91	6405	45.82	44.76	320	Pass
99	6445	45.03	45.44	320	Pass
107	6485	44.66	44.61	320	Pass
115	6525	44.86	45.02	320	Pass
123	6565	45.02	44.47	320	Pass
155	6725	45.01	44.81	320	Pass
179	6845	45.19	44.86	320	Pass
187	6885	44.96	44.78	320	Pass
211	7005	44.53	45.41	320	Pass
227	7085	44.53	44.86	320	Pass

802.11be (EHT80)

Channel	Frequency (MHz)	26dB Bandwidth (MHz)		Maximum Limit (MHz)	Test Result
		Chain 0	Chain 1		
39	6145	91.52	91.14	320	Pass
55	6225	90.98	92.11	320	Pass
87	6385	90.84	90.11	320	Pass
103	6465	93.19	90.82	320	Pass
119	6545	90.53	91.97	320	Pass
135	6625	91.52	90.21	320	Pass
151	6705	91.26	90.46	320	Pass
167	6785	90.37	89.81	320	Pass
183	6865	91.44	91.94	320	Pass
199	6945	91.68	90.76	320	Pass
215	7025	90.35	91.05	320	Pass

802.11be (EHT160)

Channel	Frequency (MHz)	26dB Bandwidth (MHz)		Maximum Limit (MHz)	Test Result
		Chain 0	Chain 1		
47	6185	174.39	174.22	320	Pass
79	6345	175.41	173.74	320	Pass
111	6505	176.22	175.16	320	Pass
143	6665	175.52	173.83	320	Pass
175	6825	175.12	173.87	320	Pass
207	6985	176.13	174.26	320	Pass

802.11be (EHT320)

Channel	Frequency (MHz)	26dB Bandwidth (MHz)		Maximum Limit (MHz)	Test Result
		Chain 0	Chain 1		
63	6265	340.18	337.51	320	Note
95	6425	341.84	342.42	320	Note
127	6585	340.29	339.93	320	Note
159	6745	342.96	338.57	320	Note
191	6905	343.85	339.70	320	Note

Note: Please refer to 99% OBW measurement test results for Wi-Fi 320 MHz BW mode.

Spectrum Plot of Maximum Value

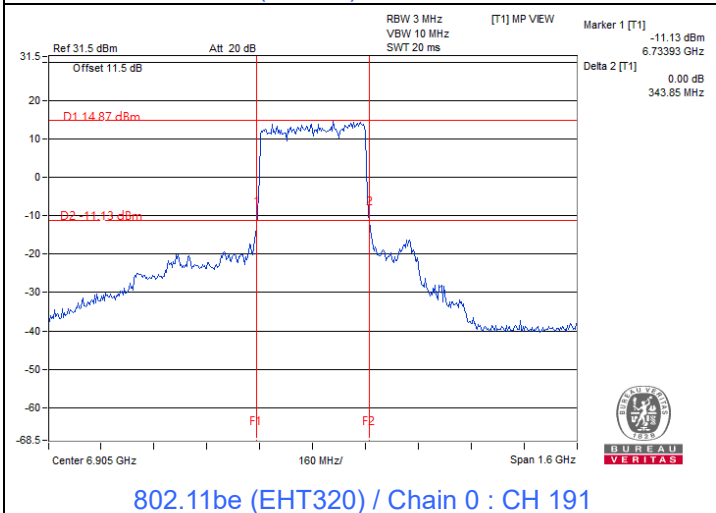
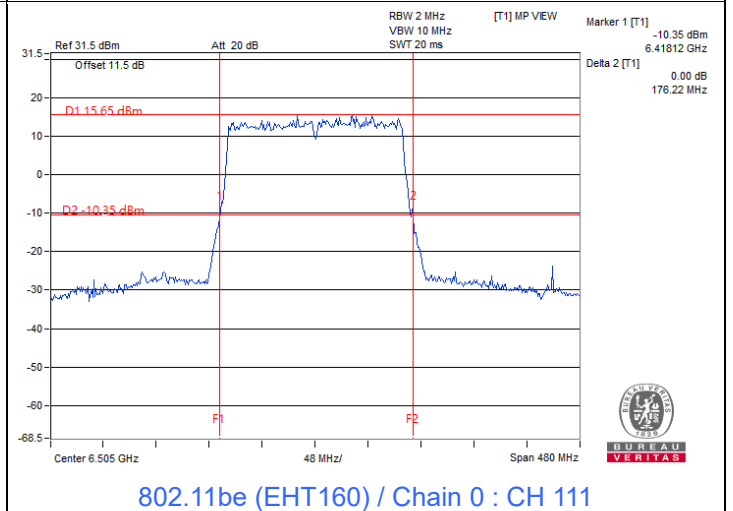
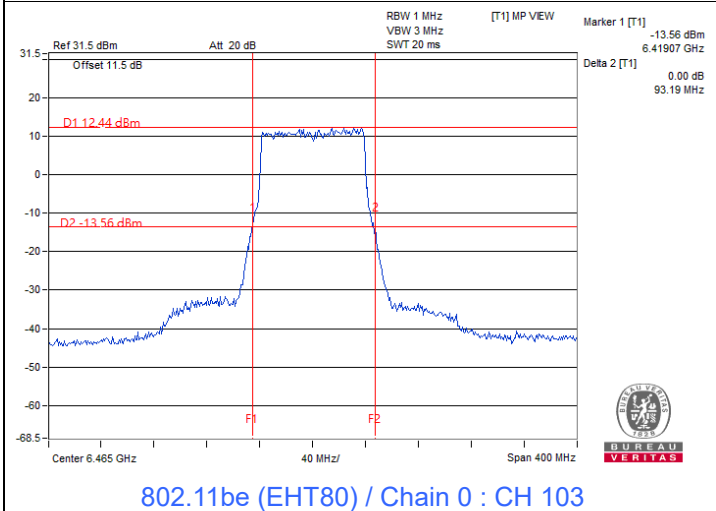
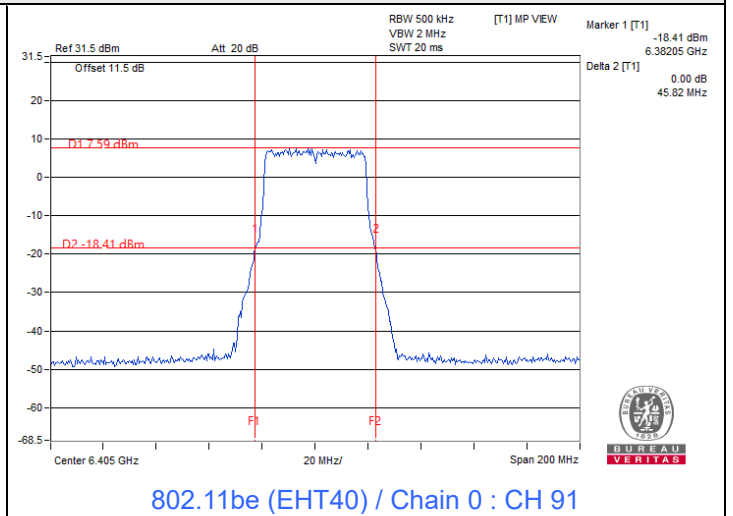
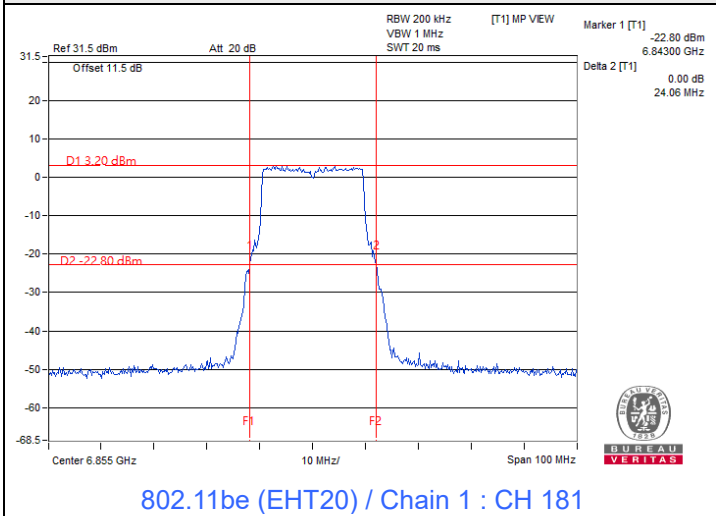

7.4 In-Band Emission Mask

Input Power:	120 Vac, 60 Hz	Environmental Conditions:	25°C, 60% RH	Tested By:	Ivan Tseng, Matthew Yang, Tim Chen, Jisyong Wang
--------------	----------------	---------------------------	--------------	------------	--

802.11a

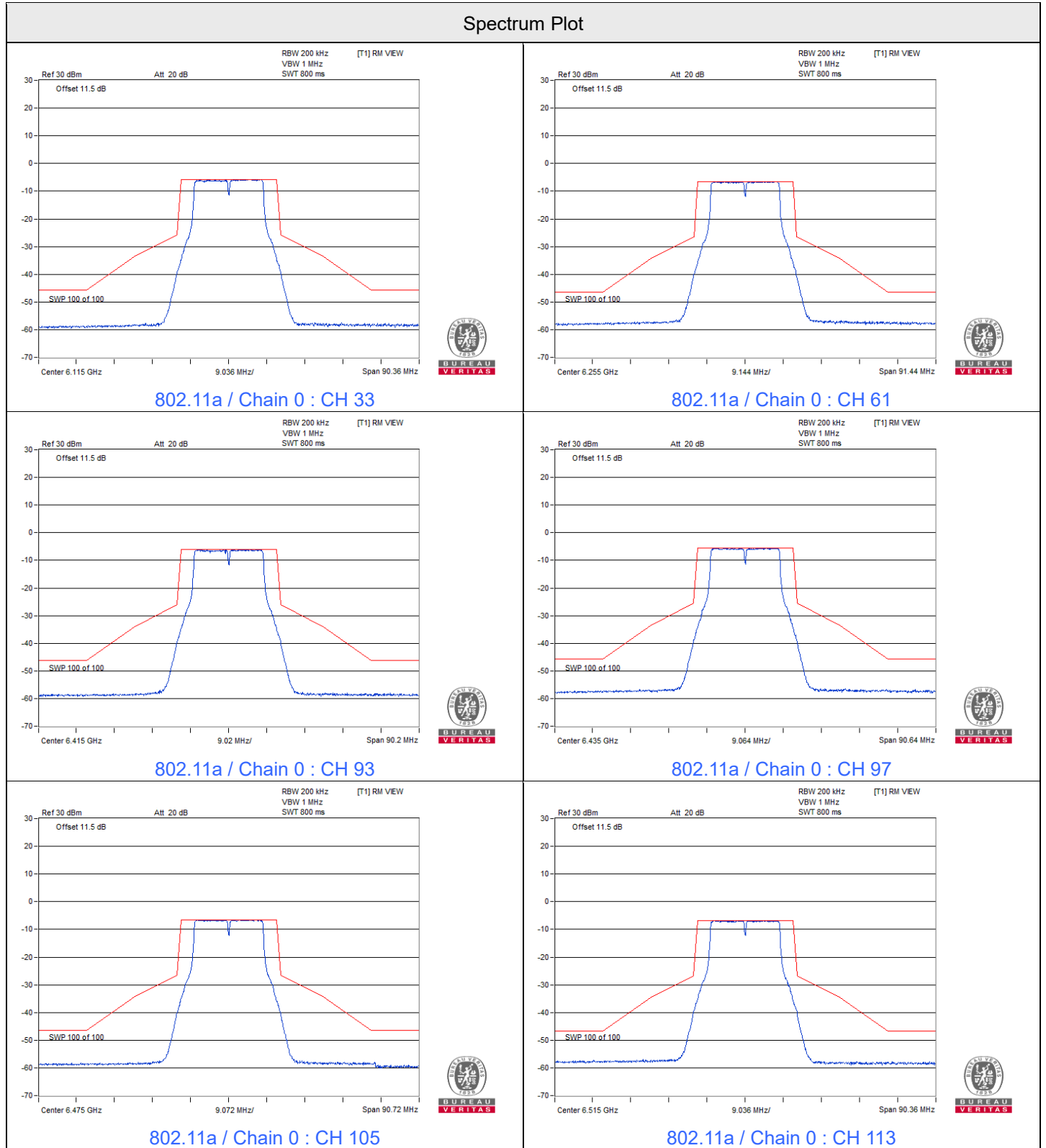

Spectrum Plot

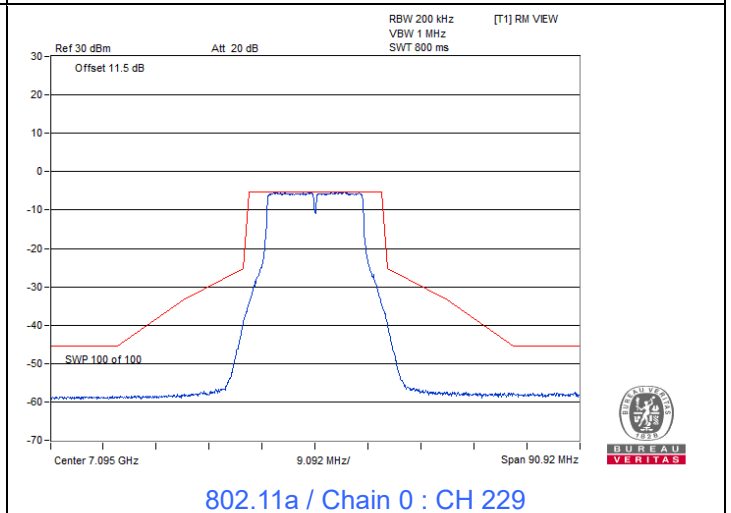
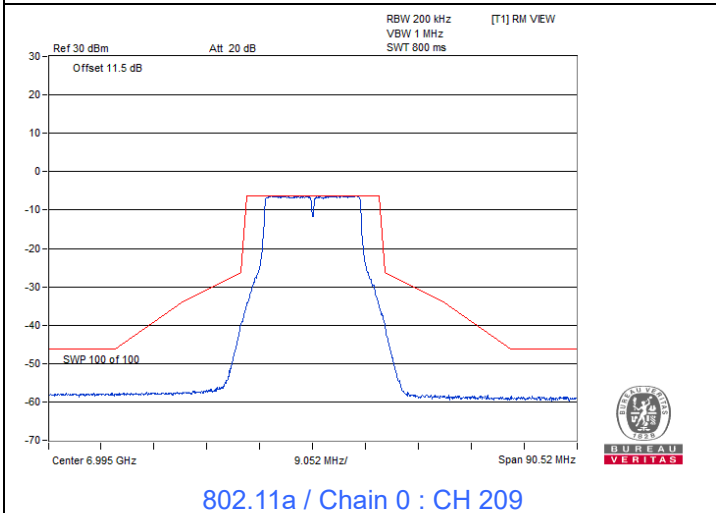
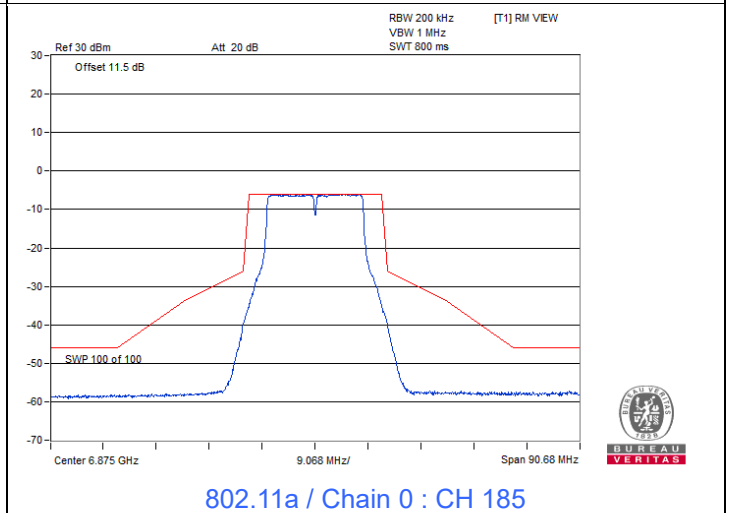
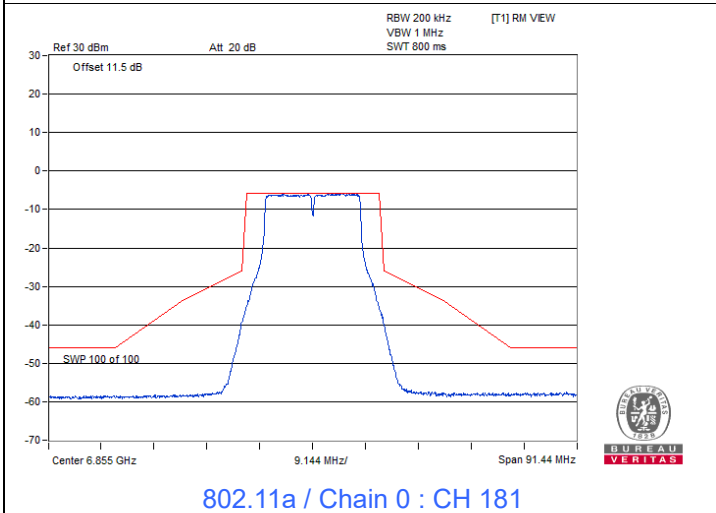
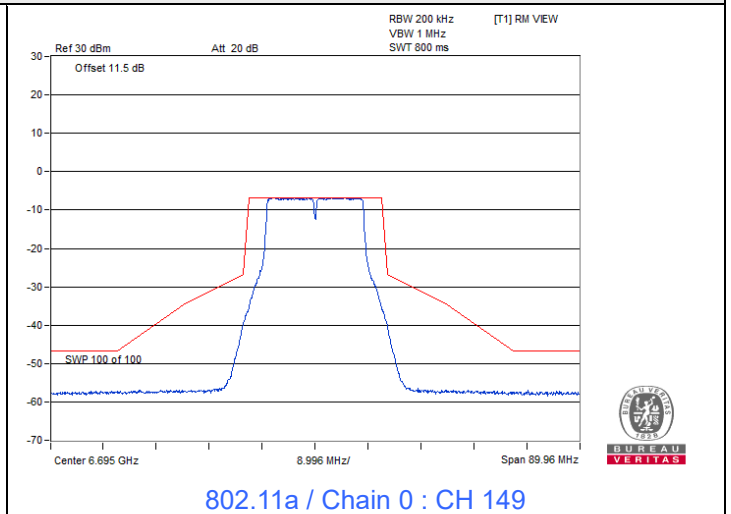
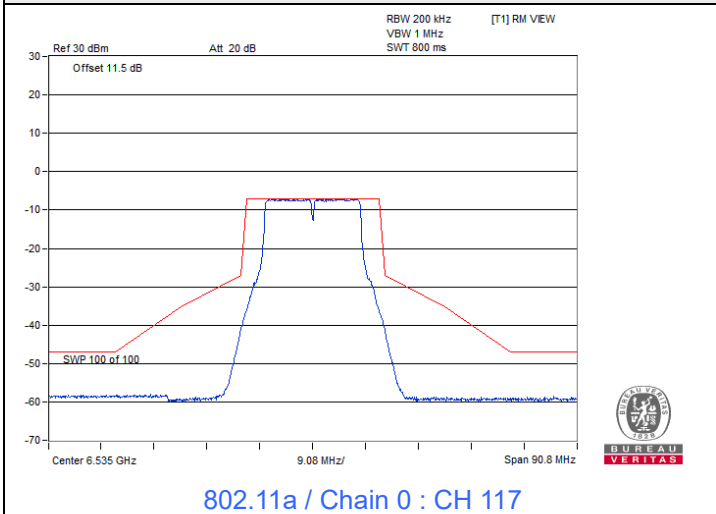

Spectrum Plot

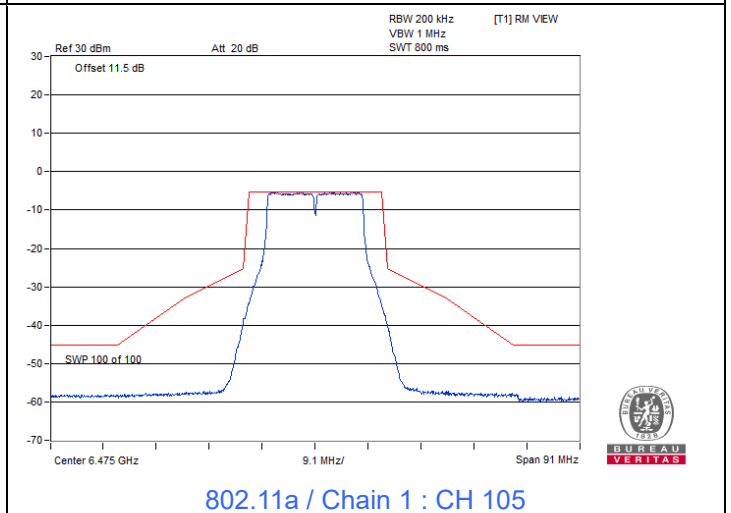
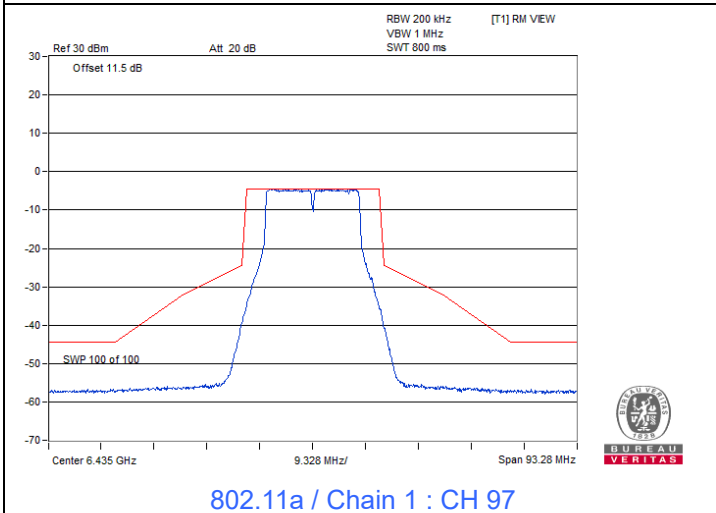
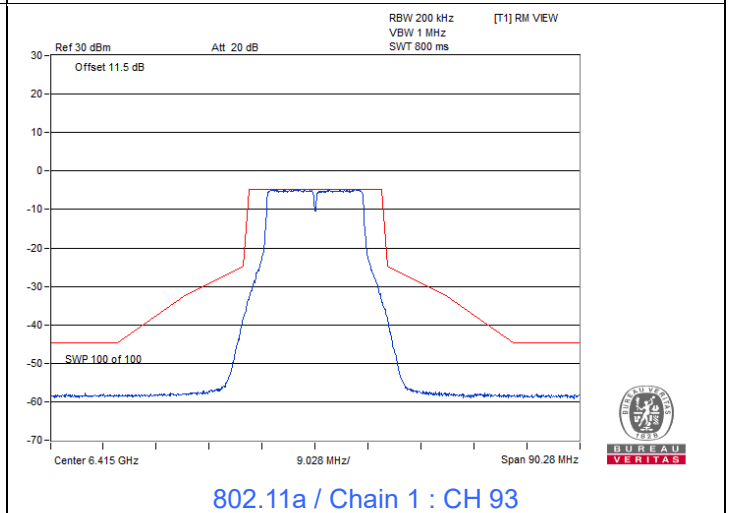
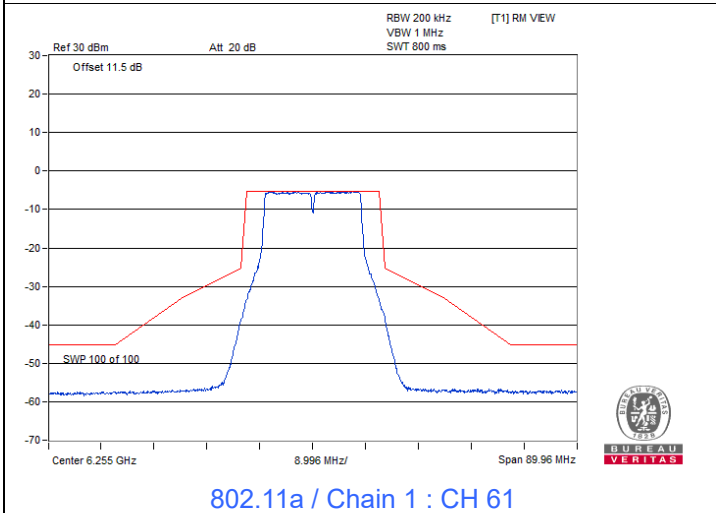
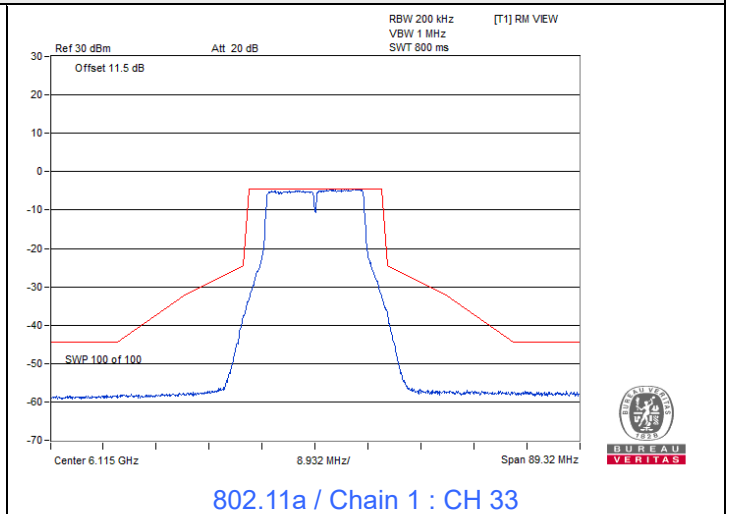
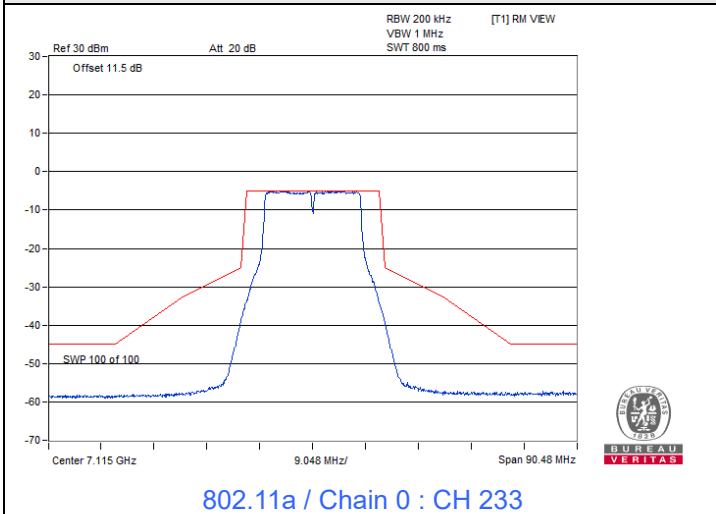

Spectrum Plot

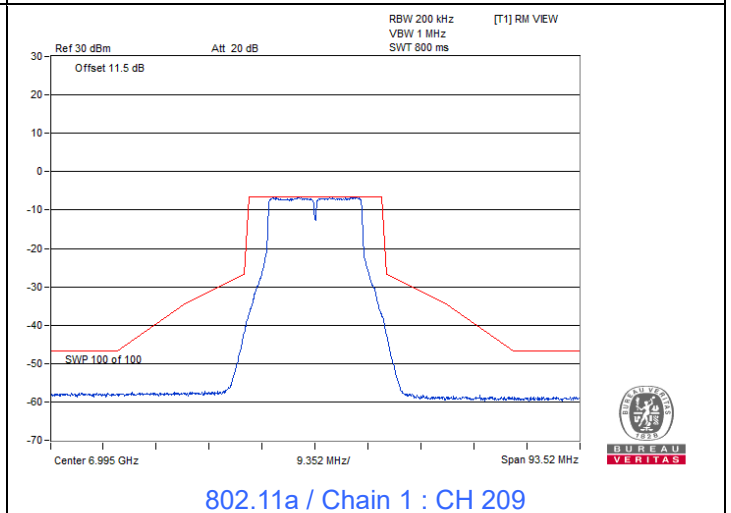
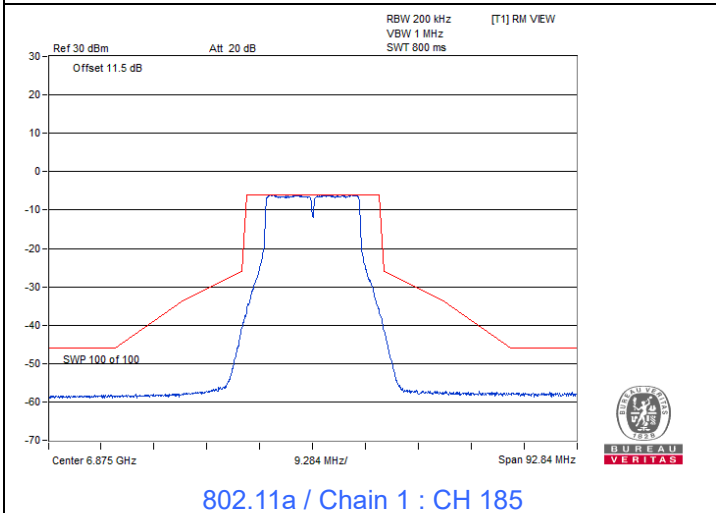
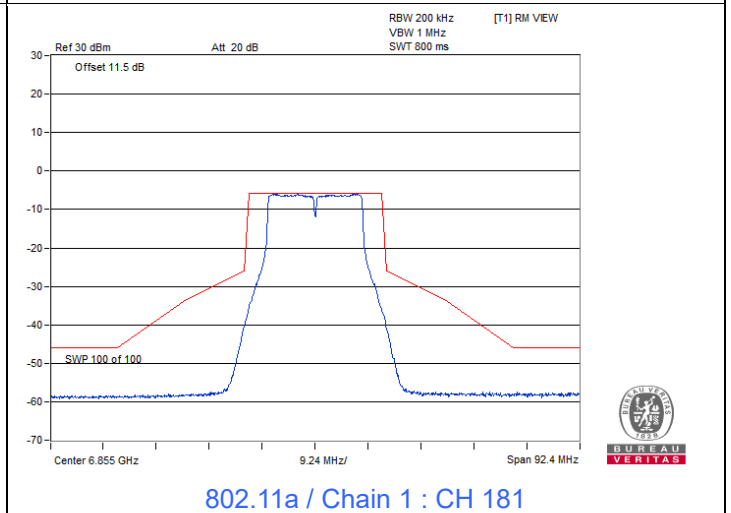
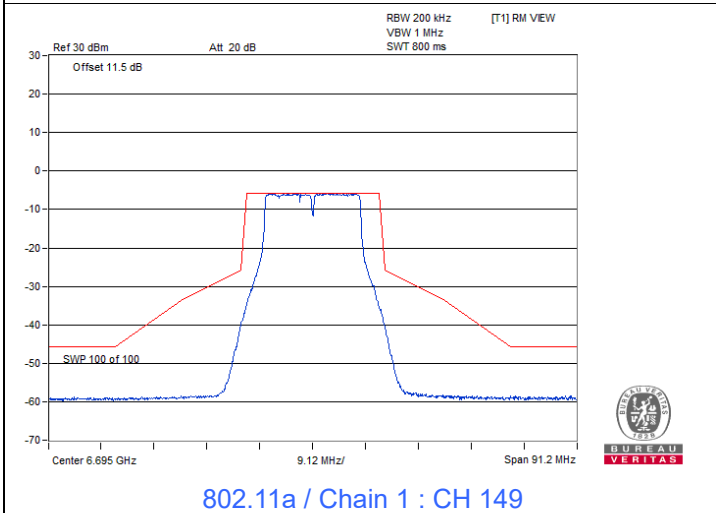
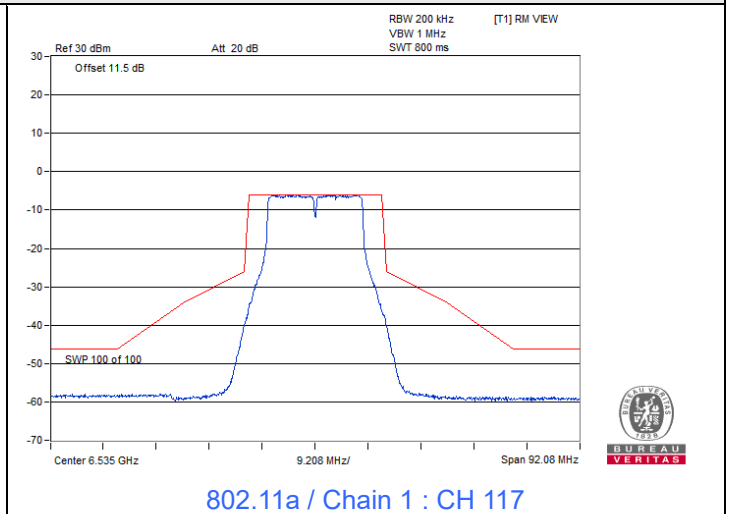
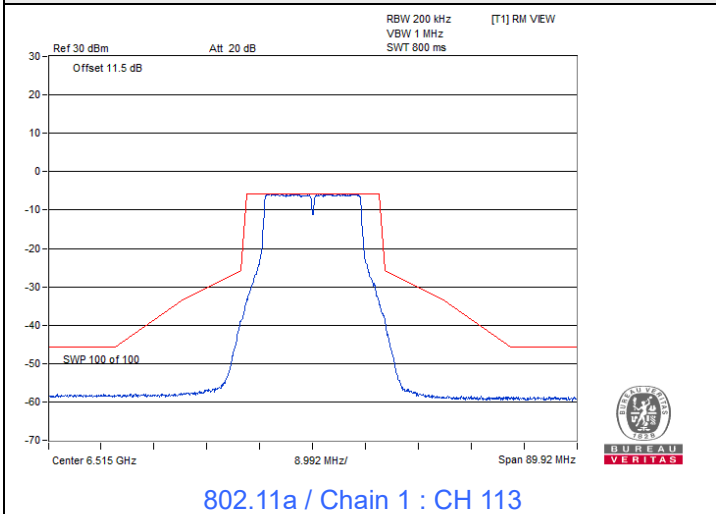



Spectrum Plot

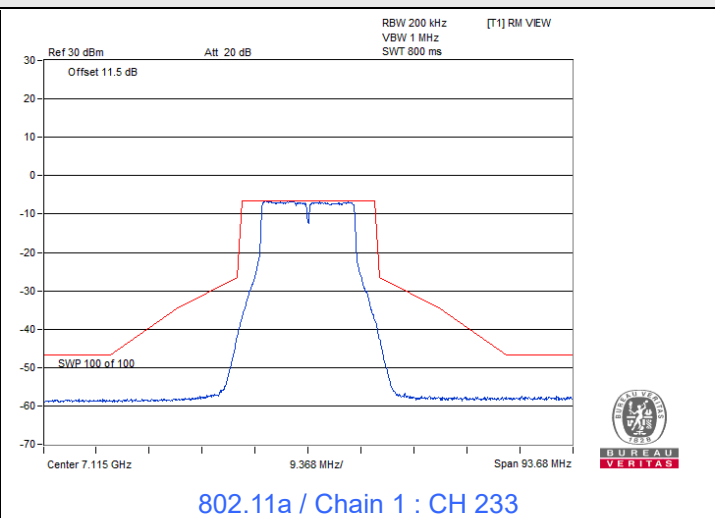
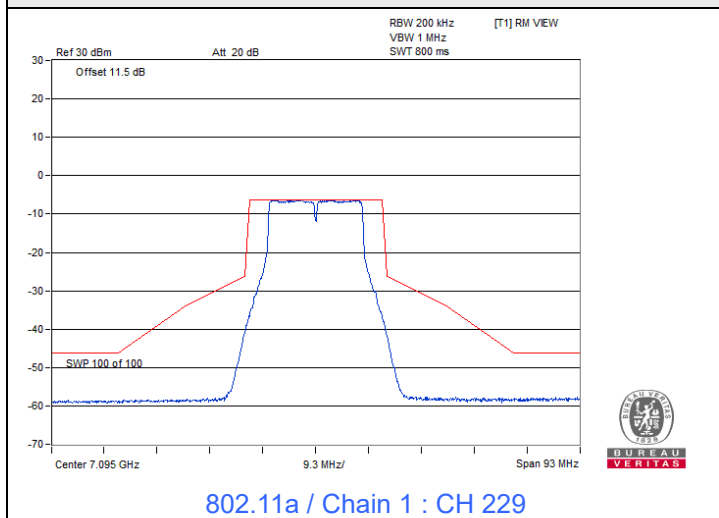



Beamforming (2T1S)

802.11be (EHT20)

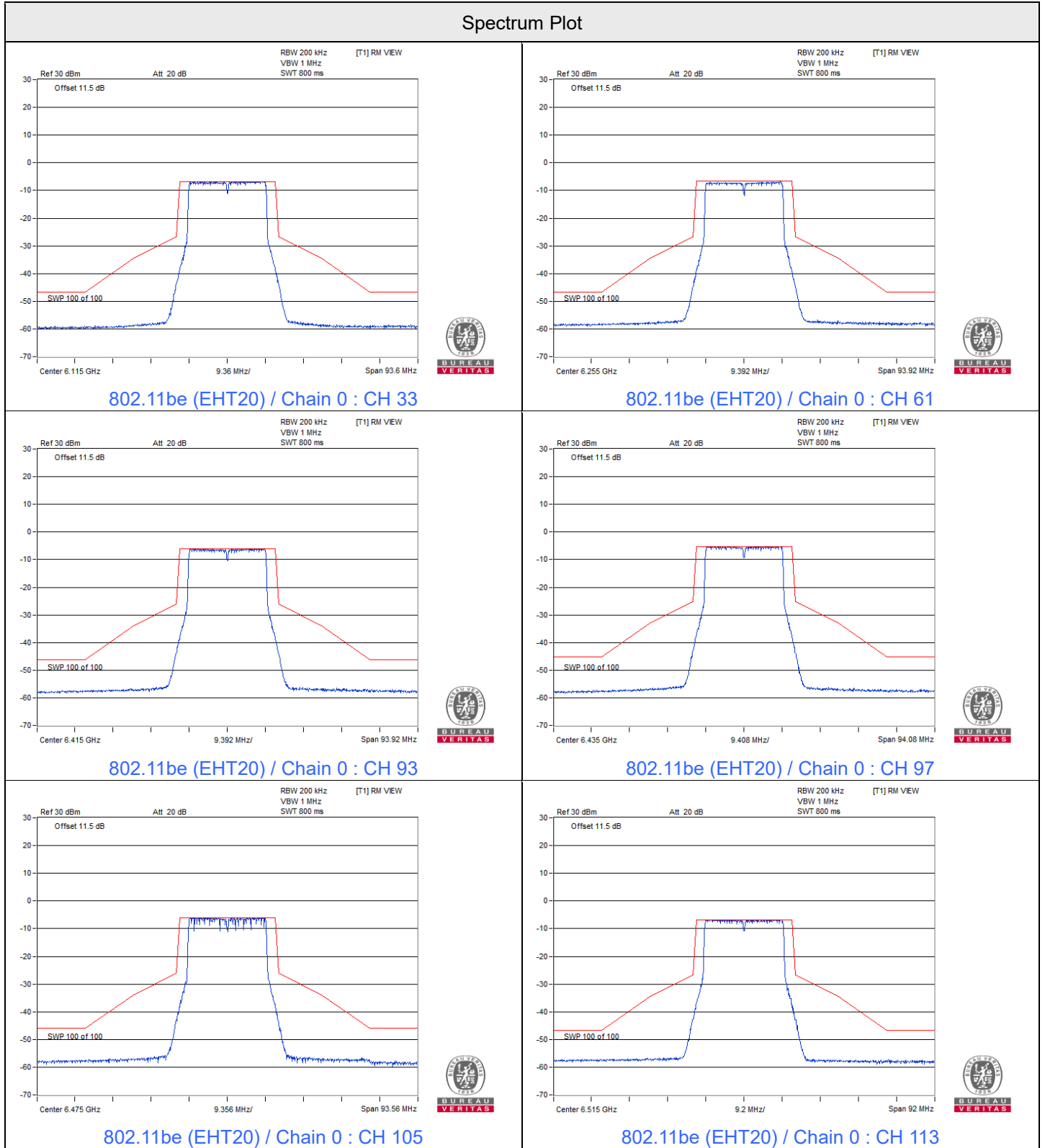

Spectrum Plot

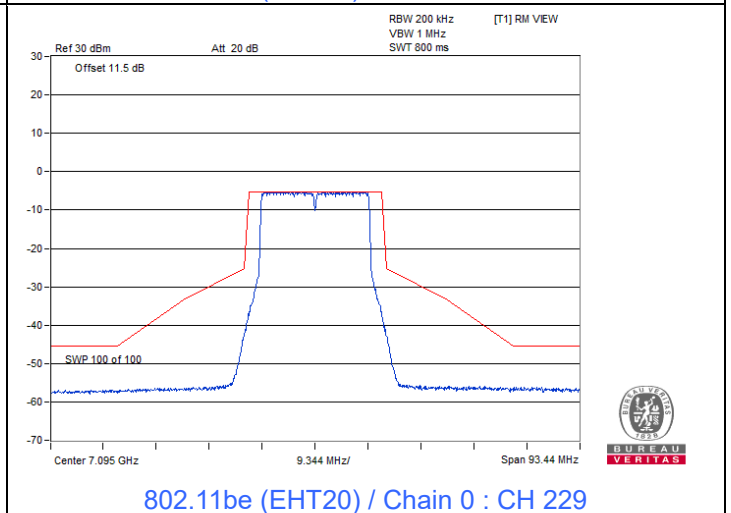
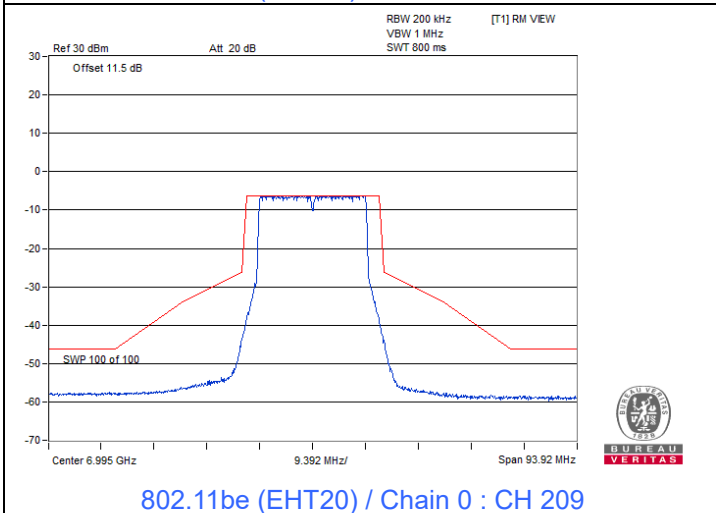
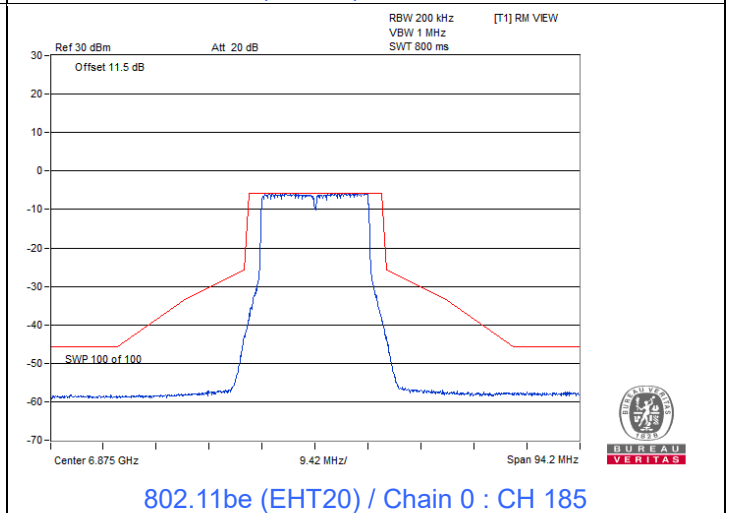
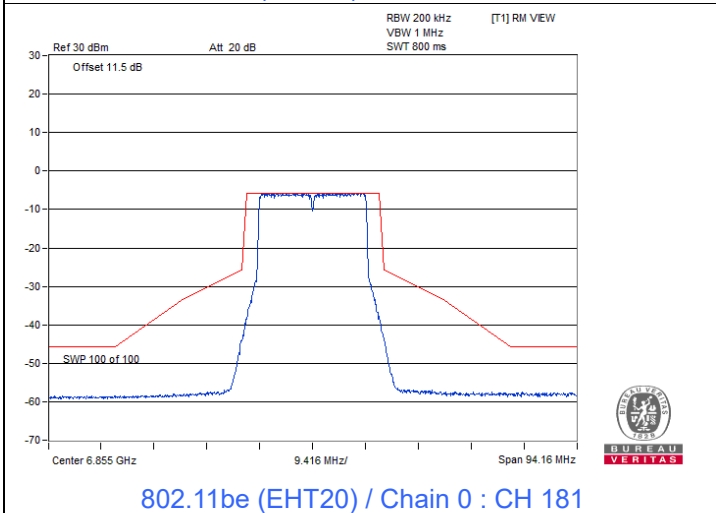
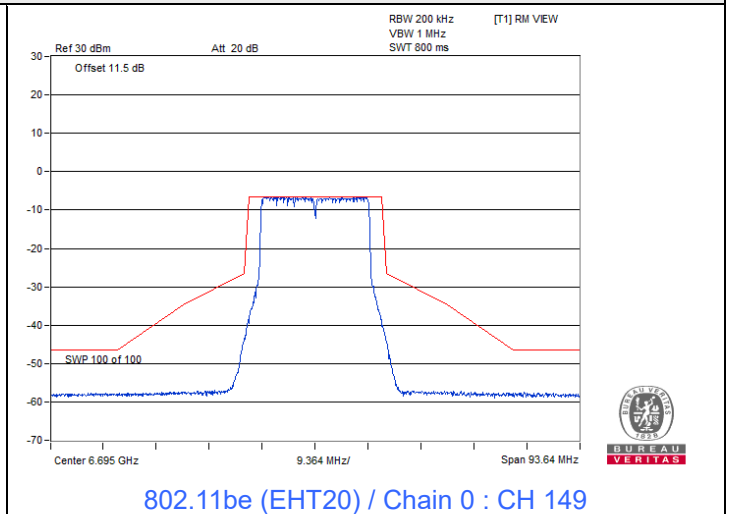
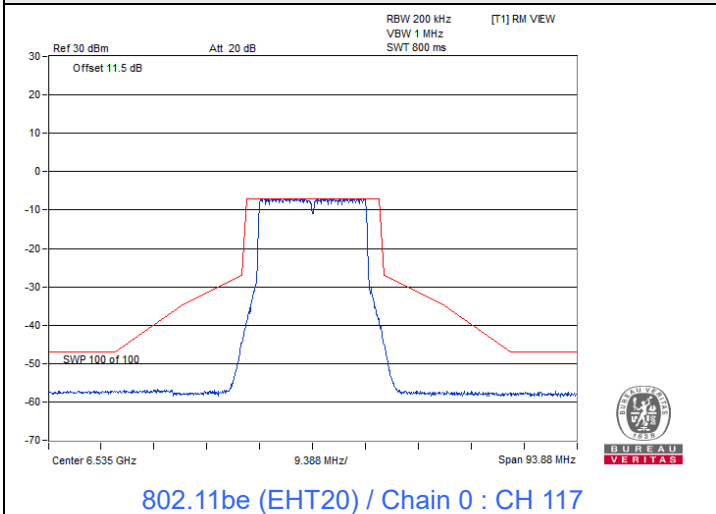

Spectrum Plot

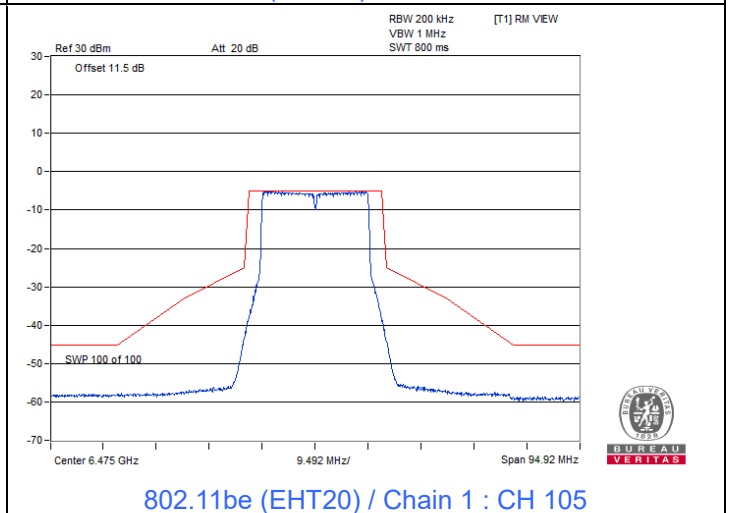
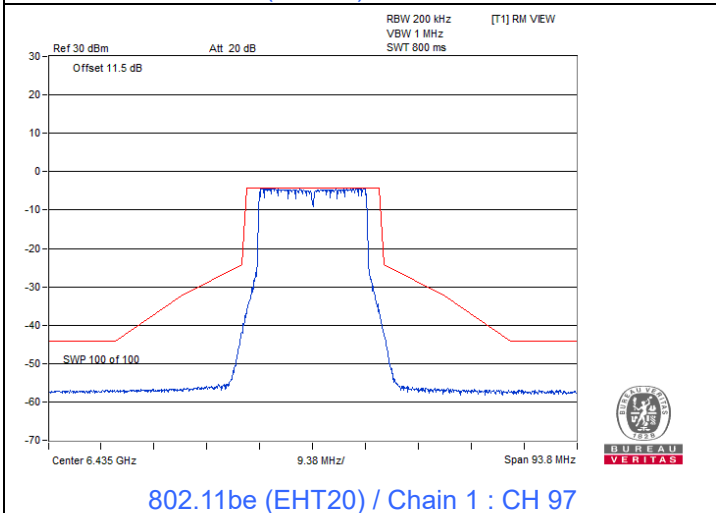
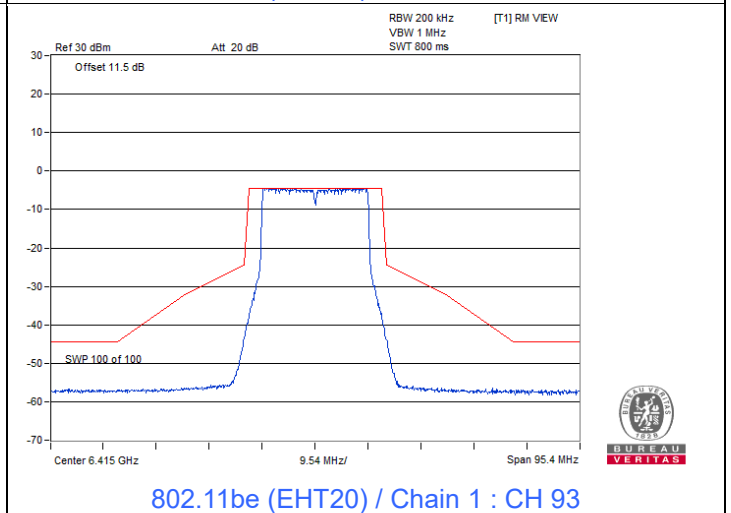
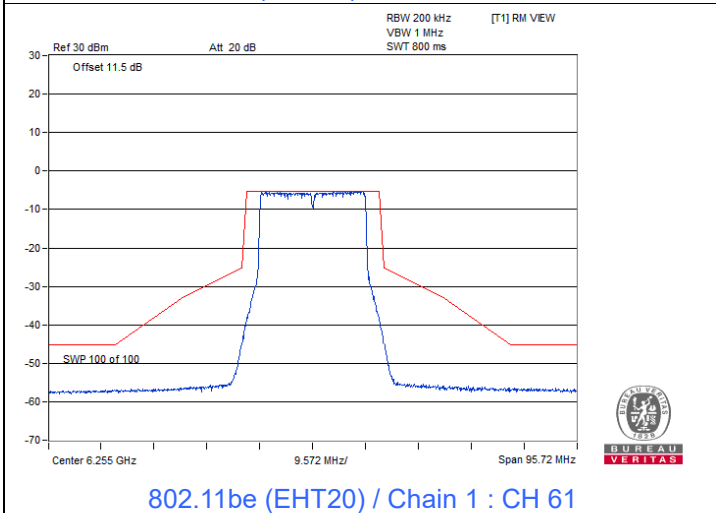
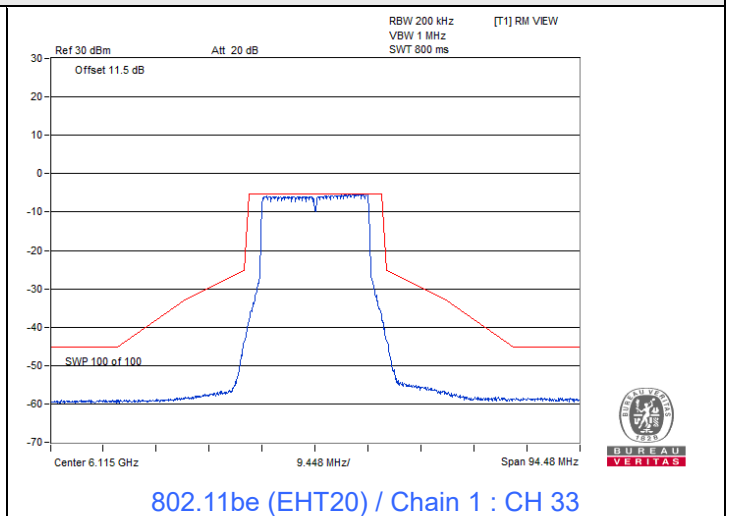
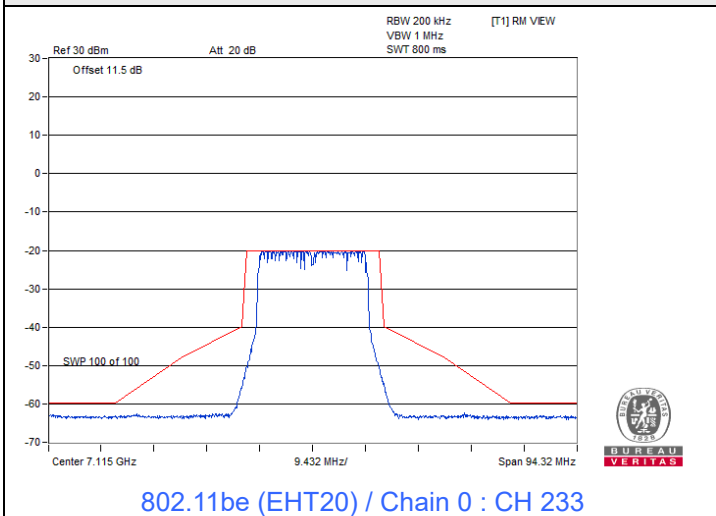

Spectrum Plot

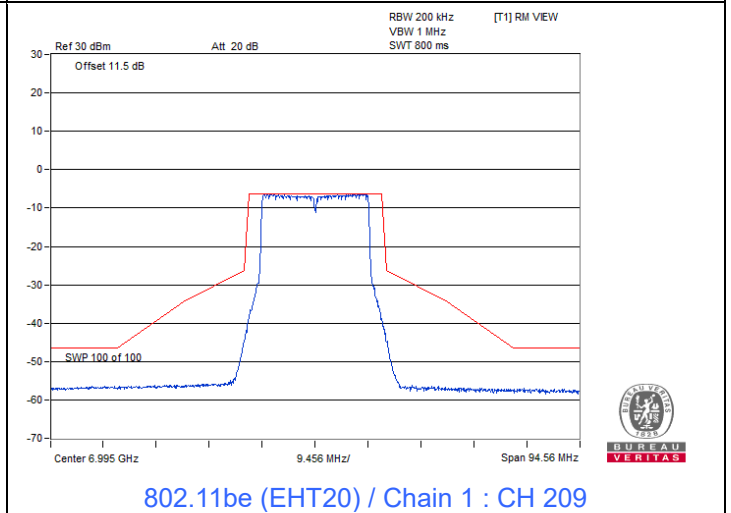
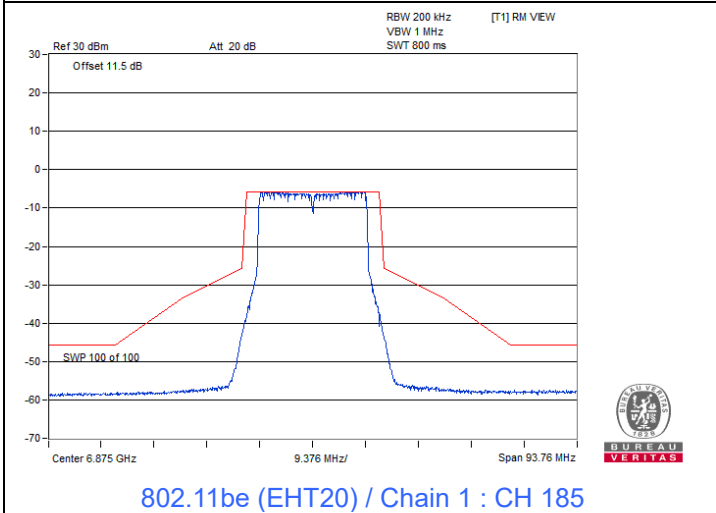
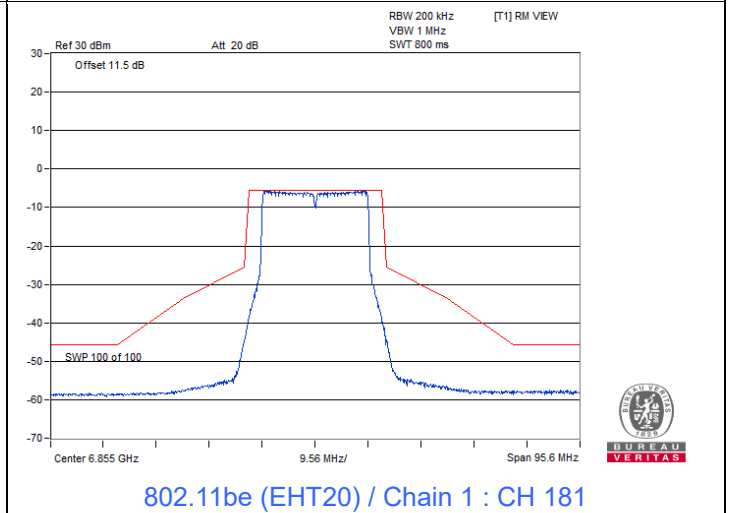
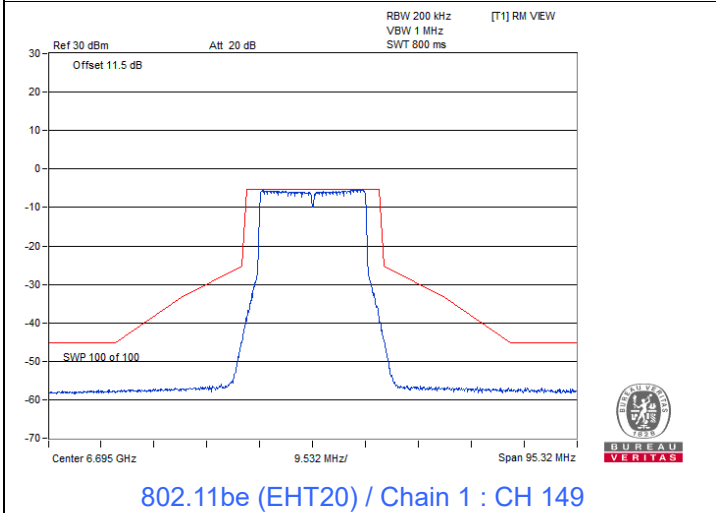
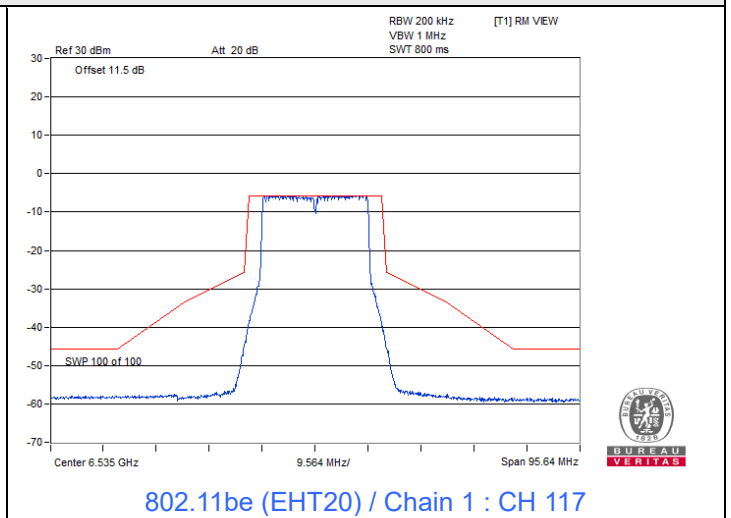
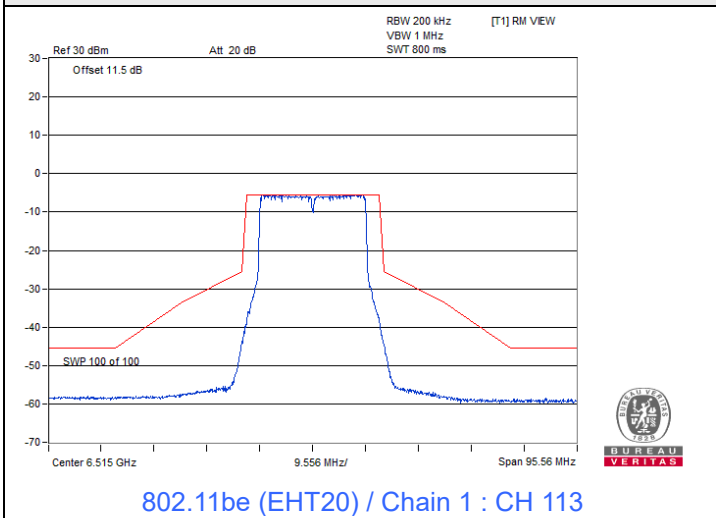

Spectrum Plot

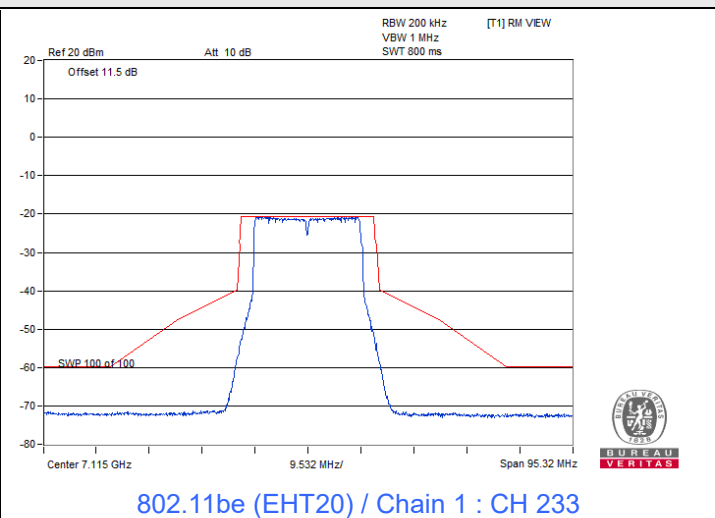
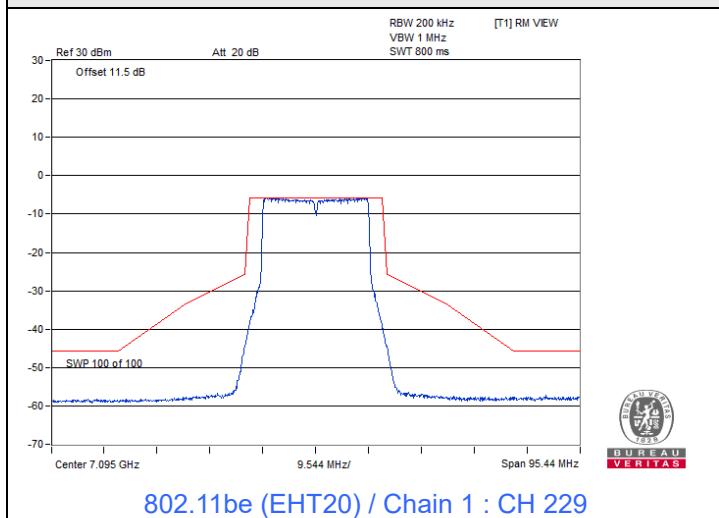



802.11be (EHT40)

Spectrum Plot

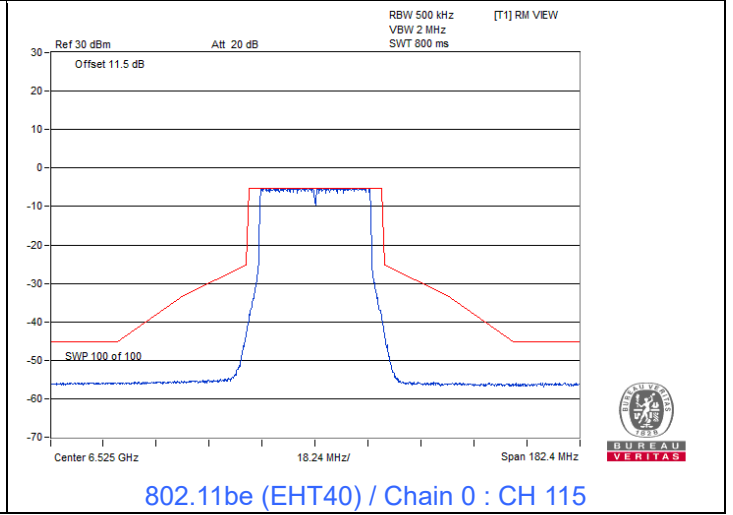
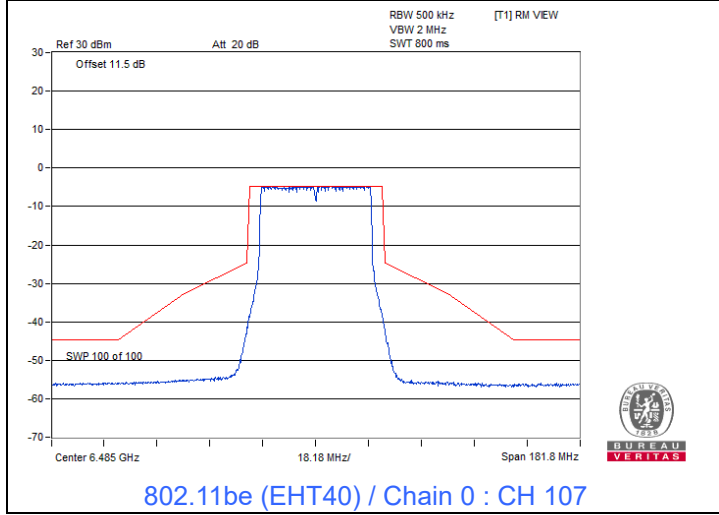
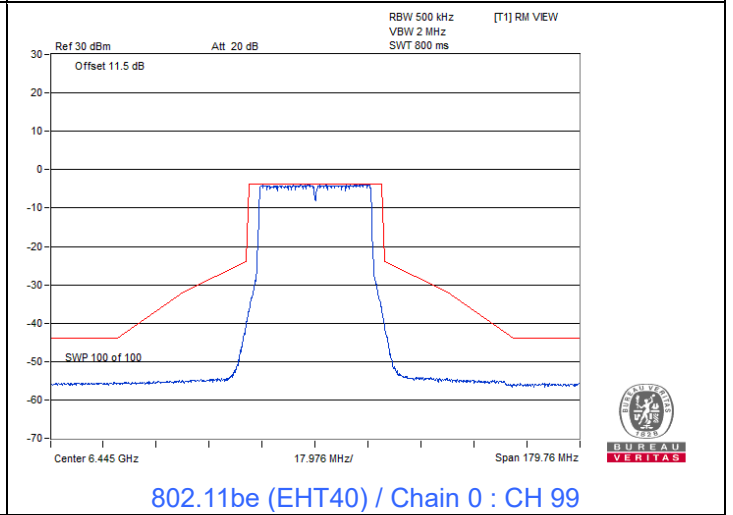
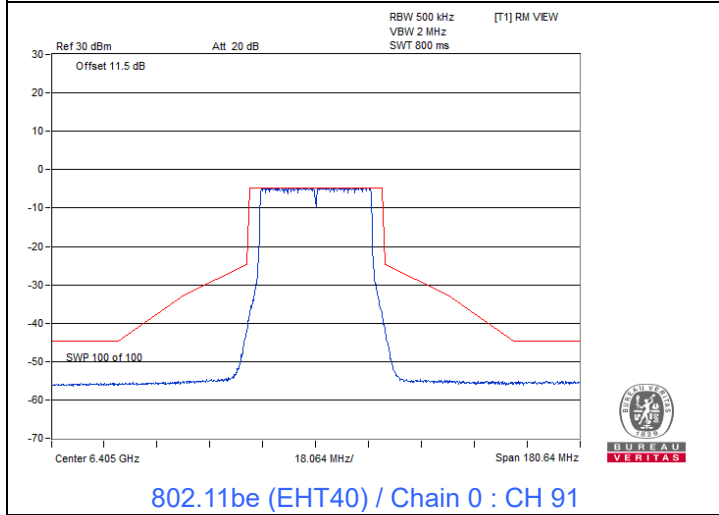
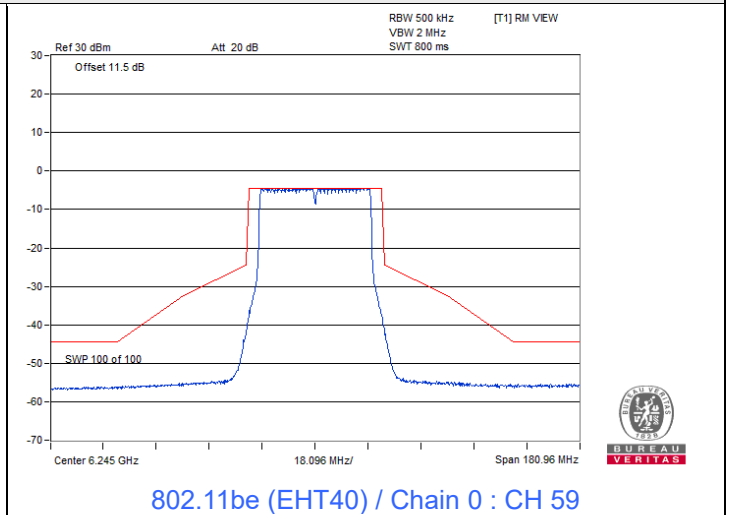
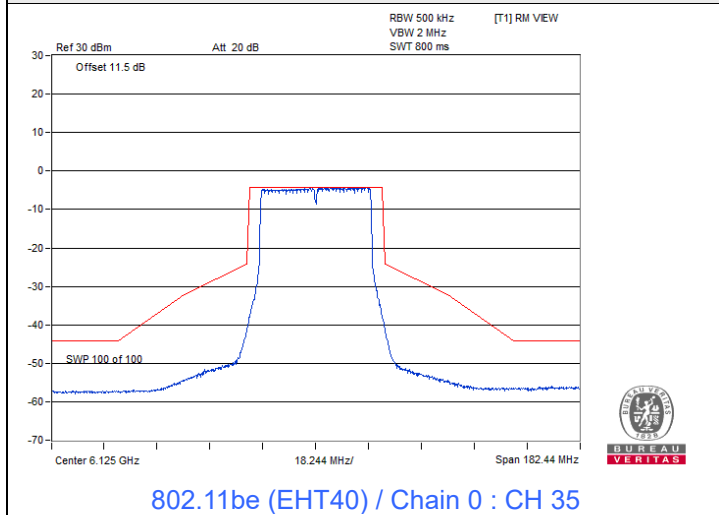

Spectrum Plot

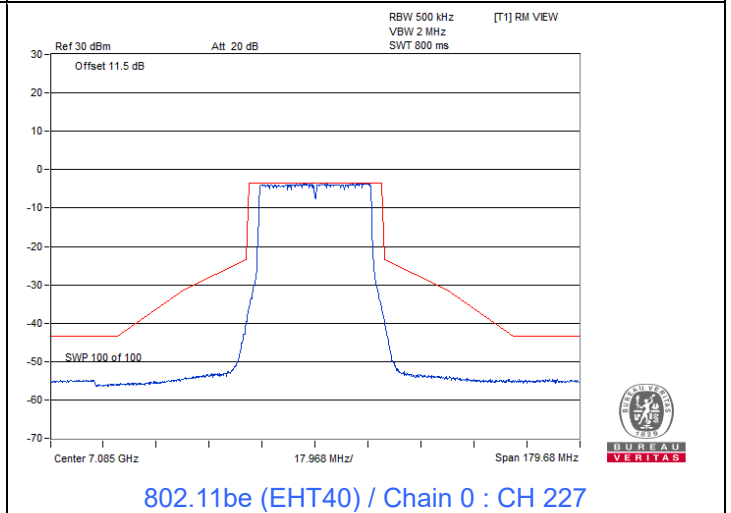
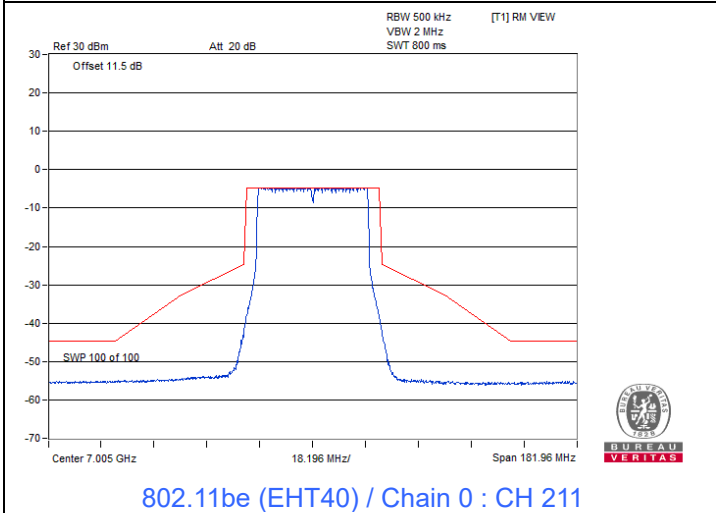
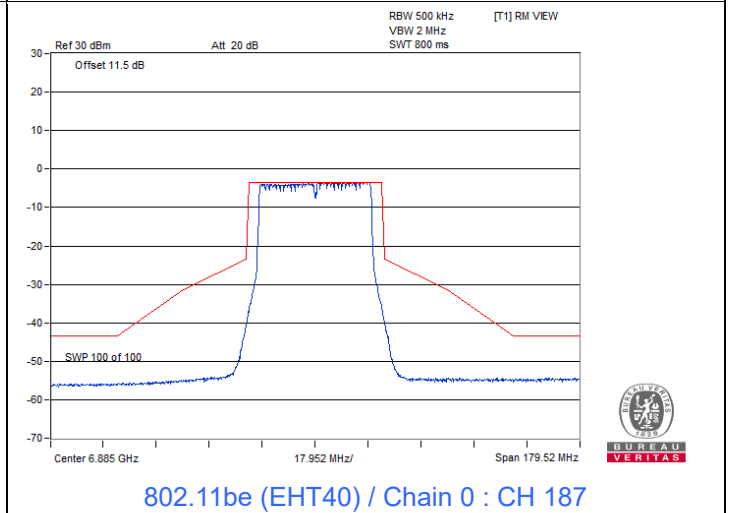
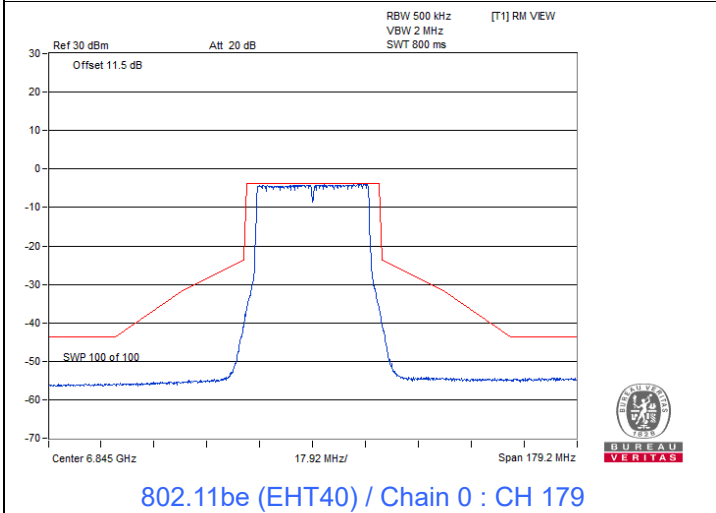
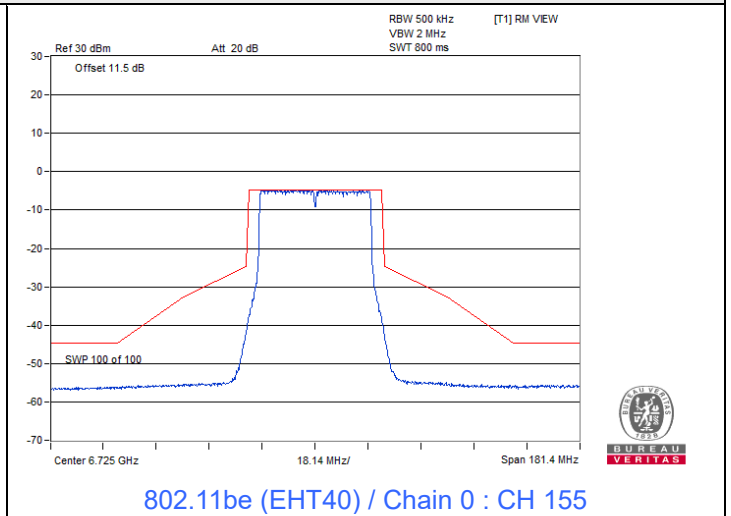
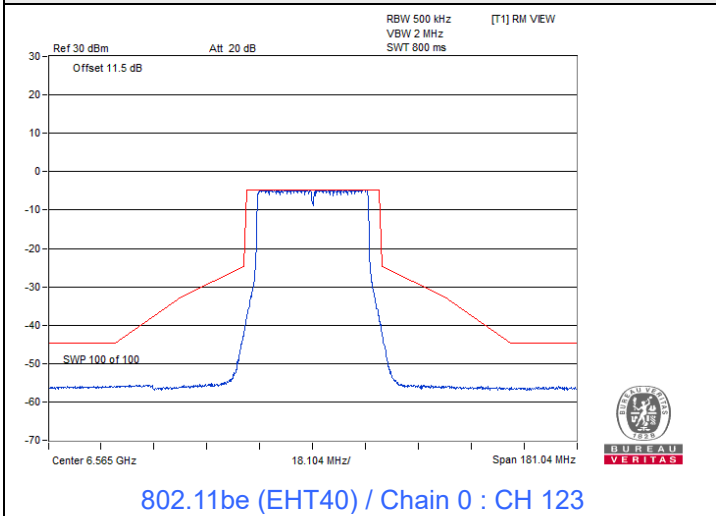

Spectrum Plot

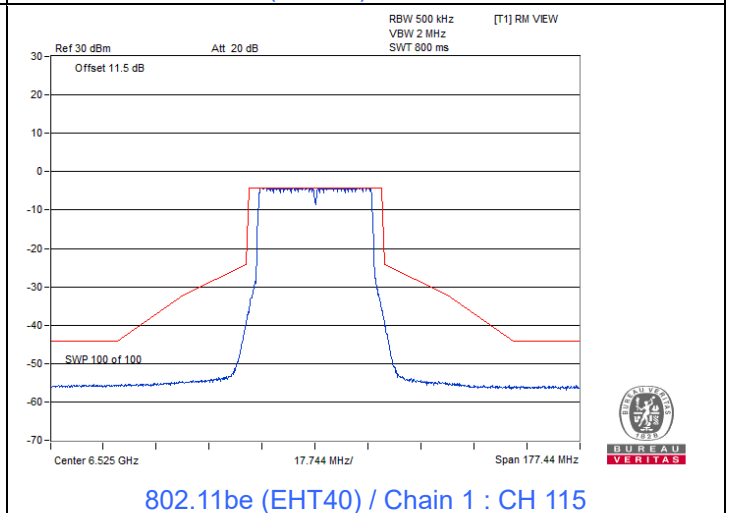
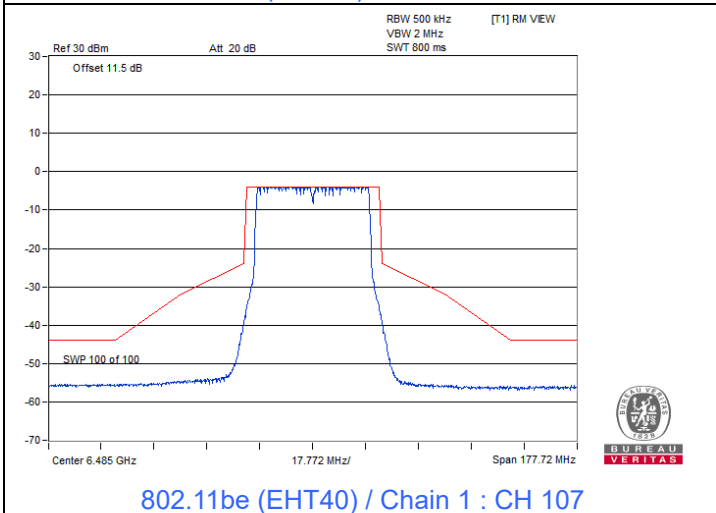
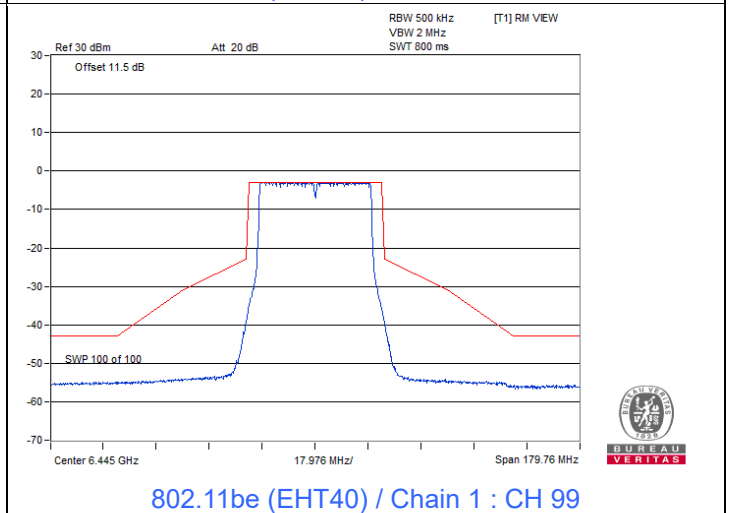
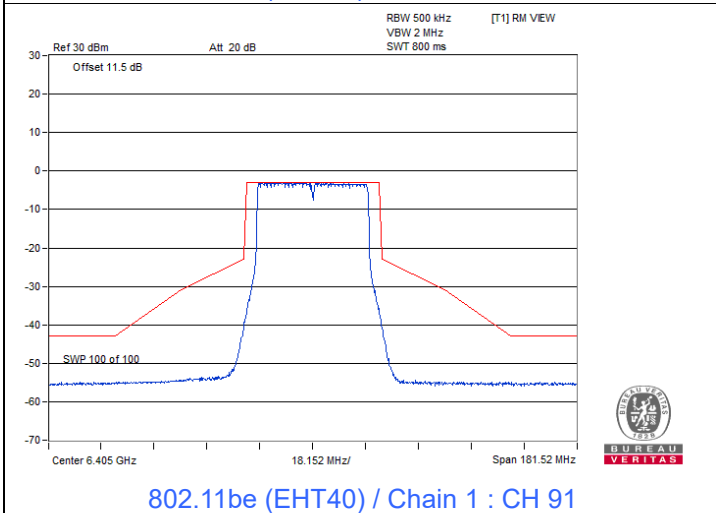
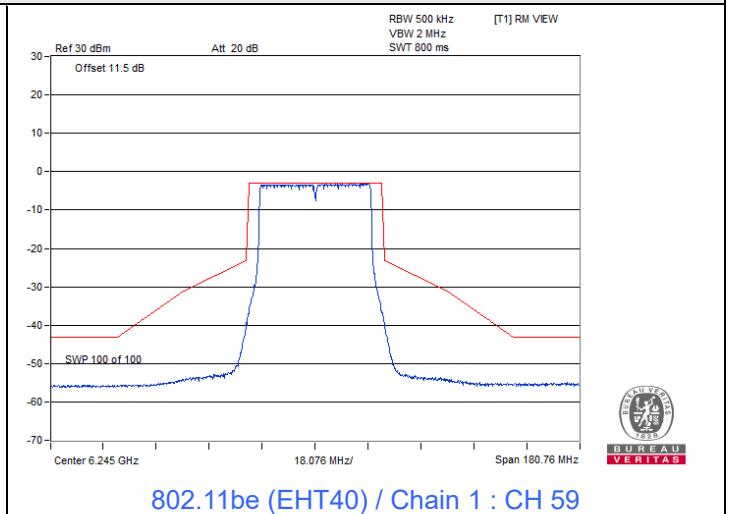
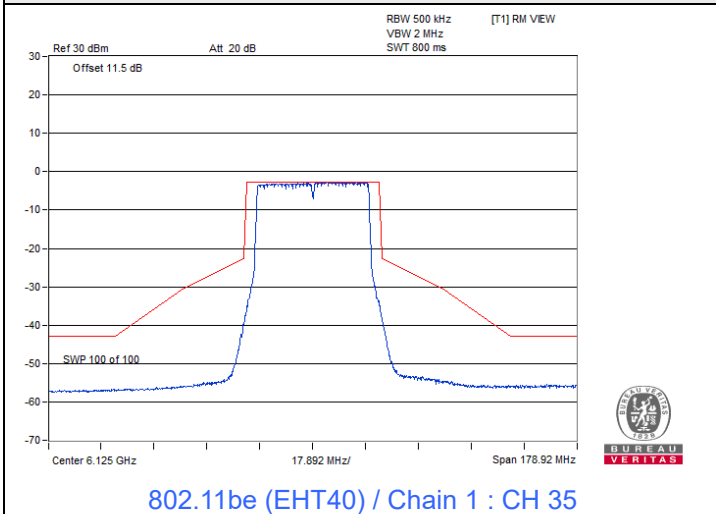

Spectrum Plot

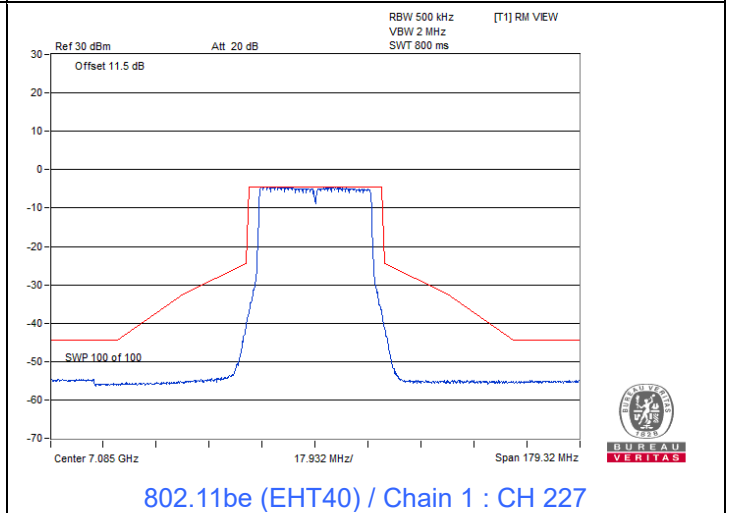
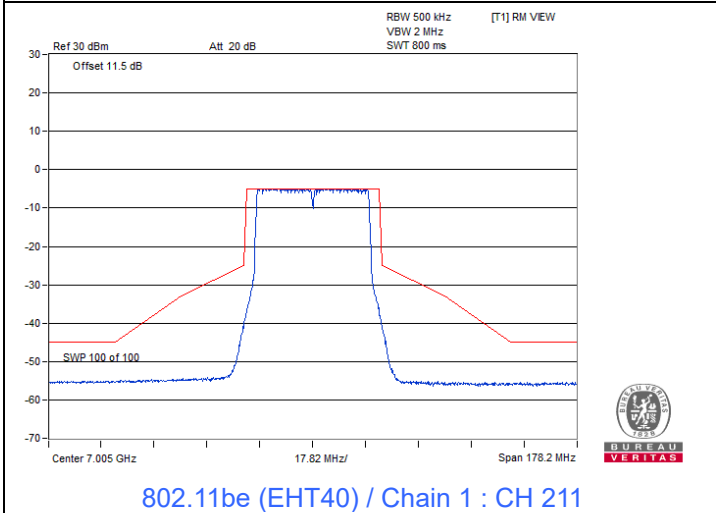
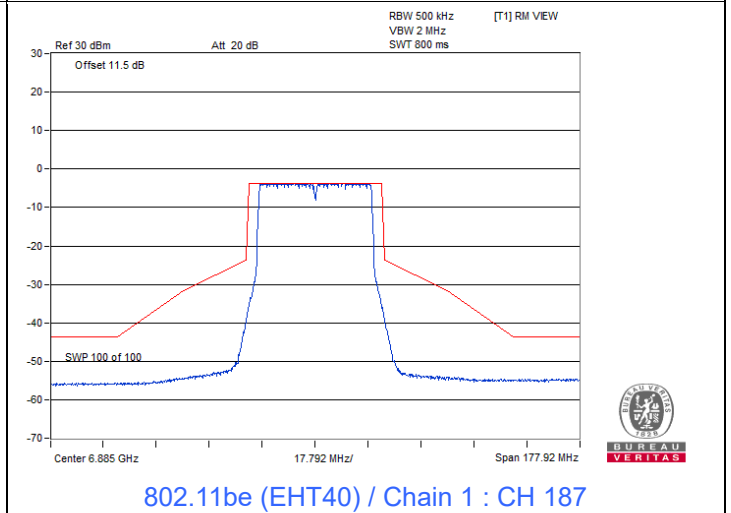
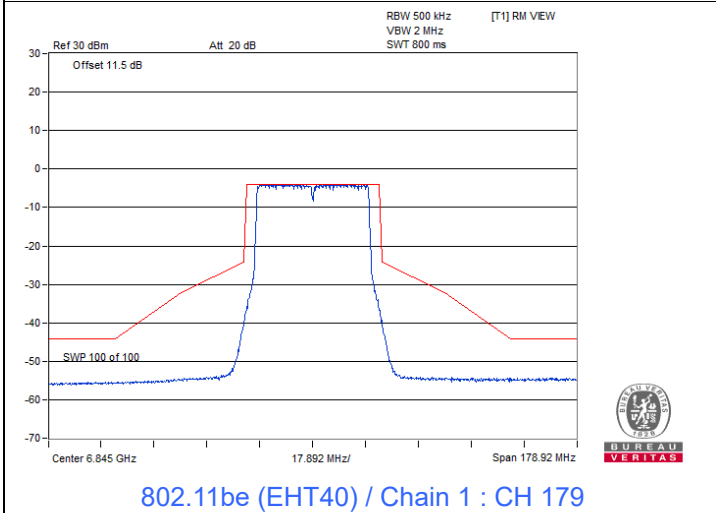
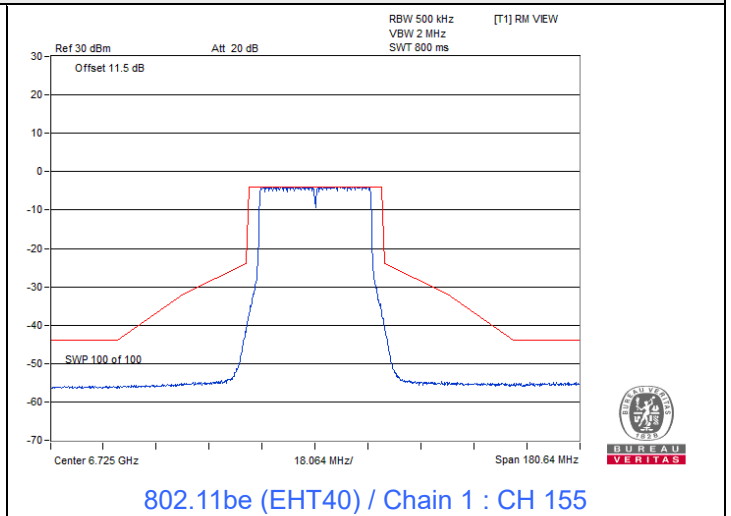
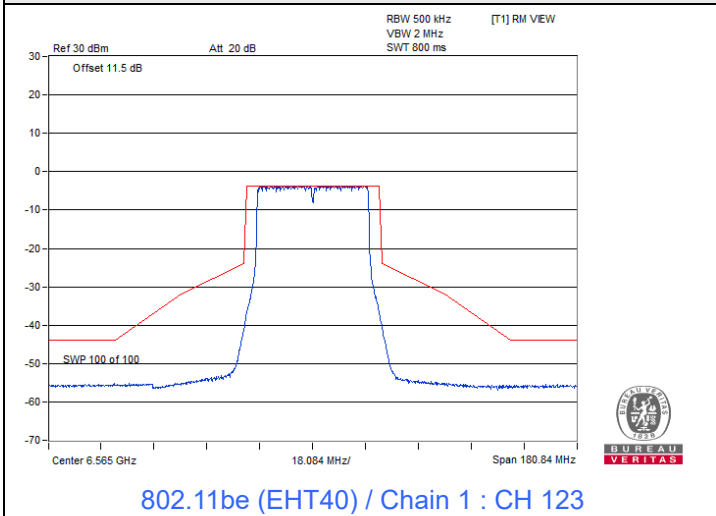



802.11be (EHT80)

Spectrum Plot

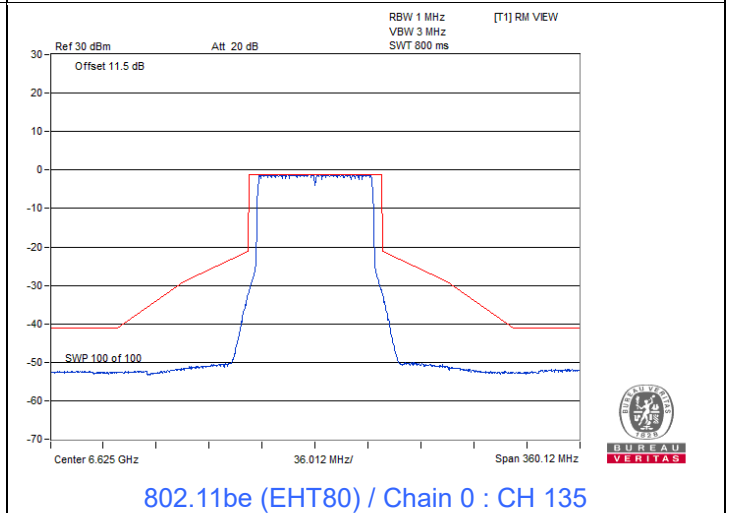
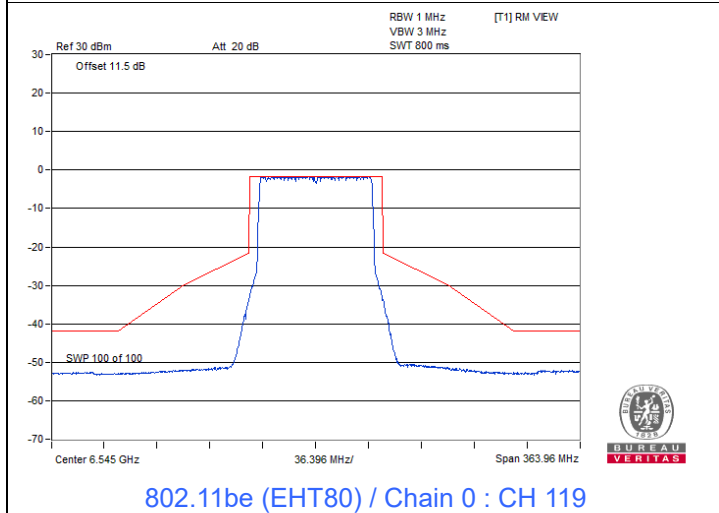
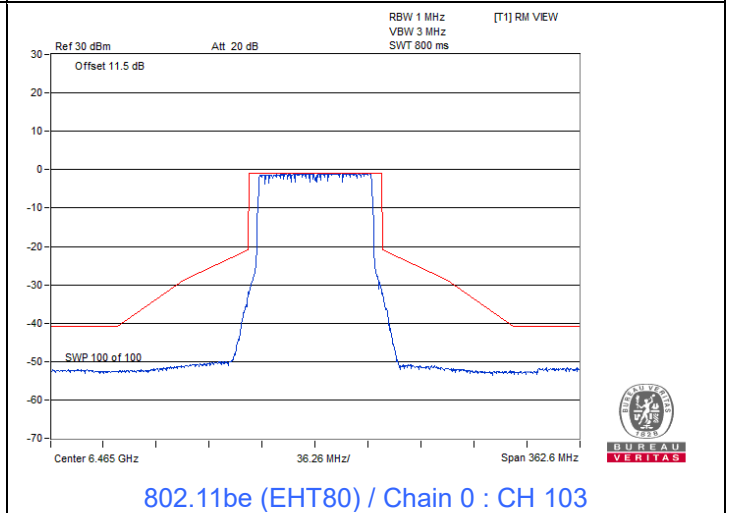
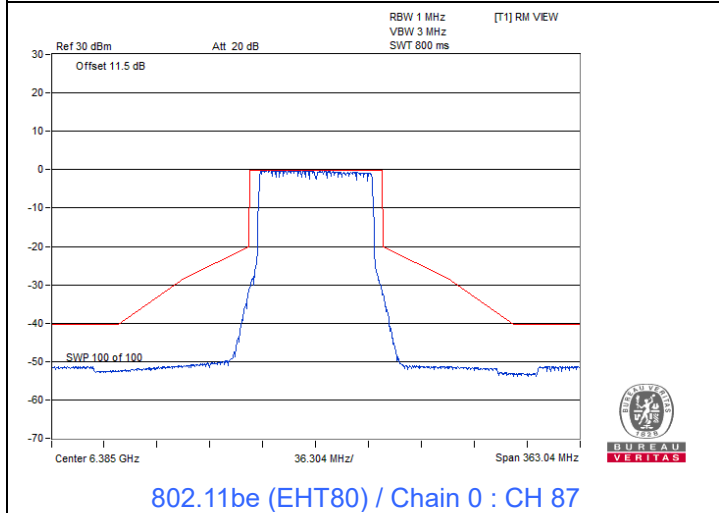
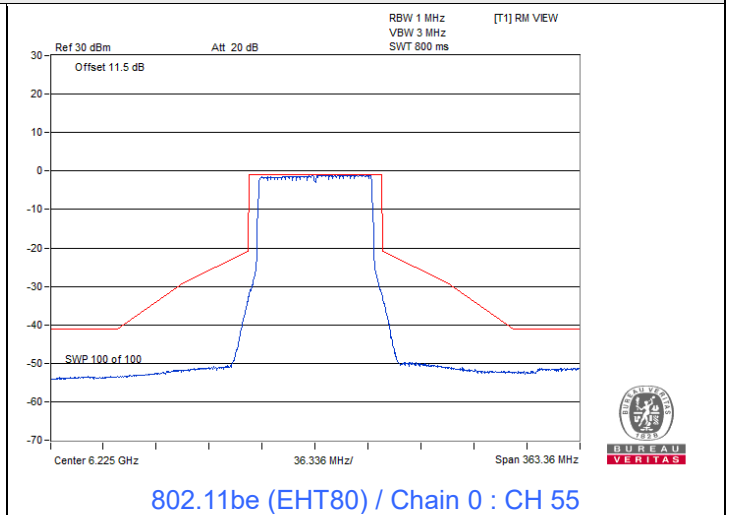
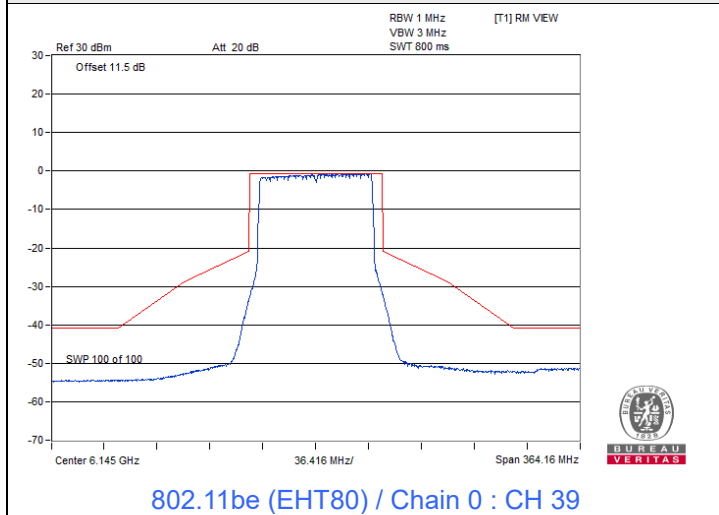

Spectrum Plot

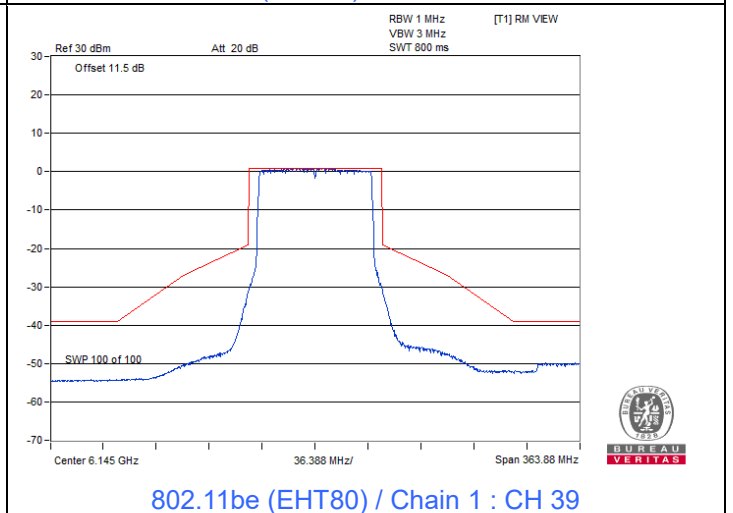
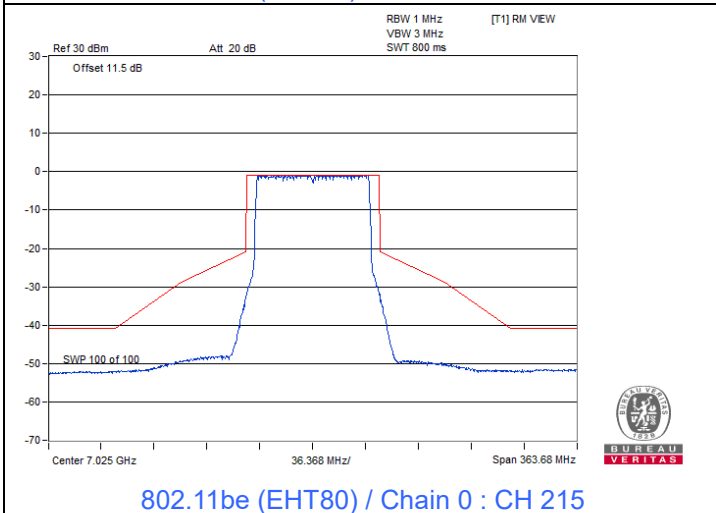
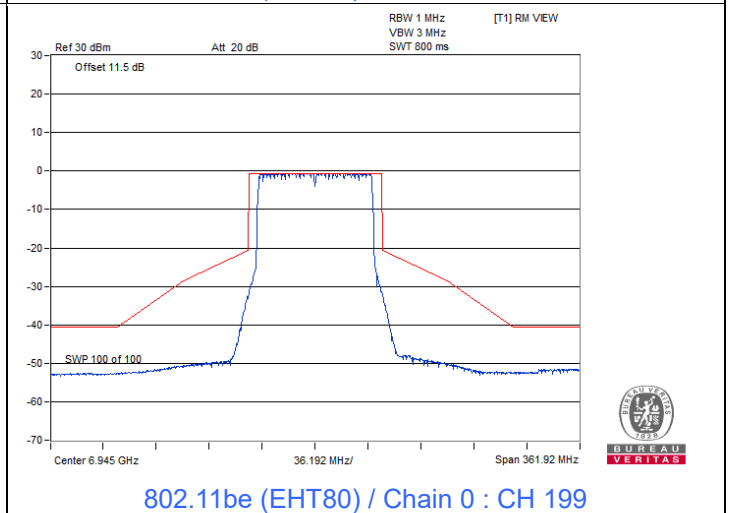
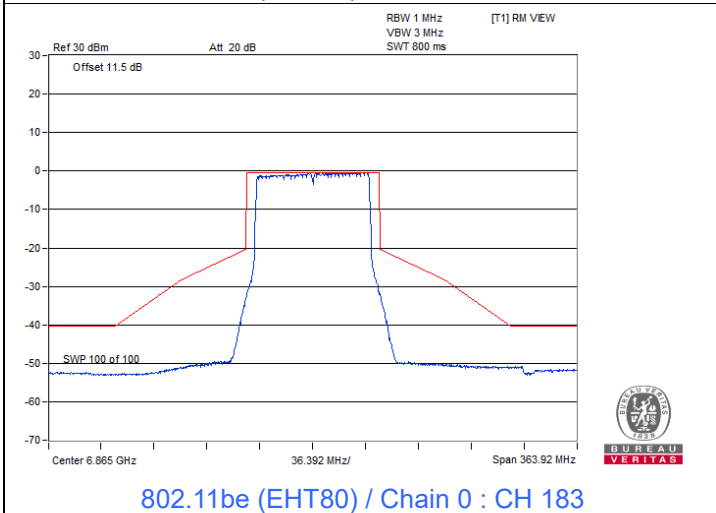
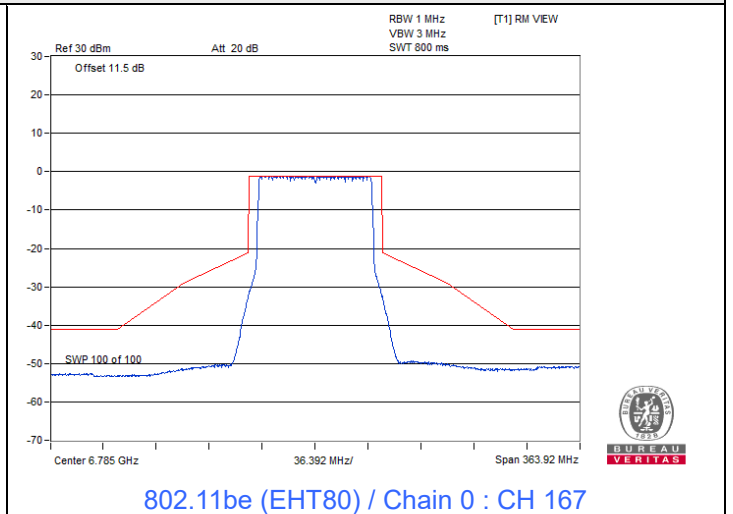
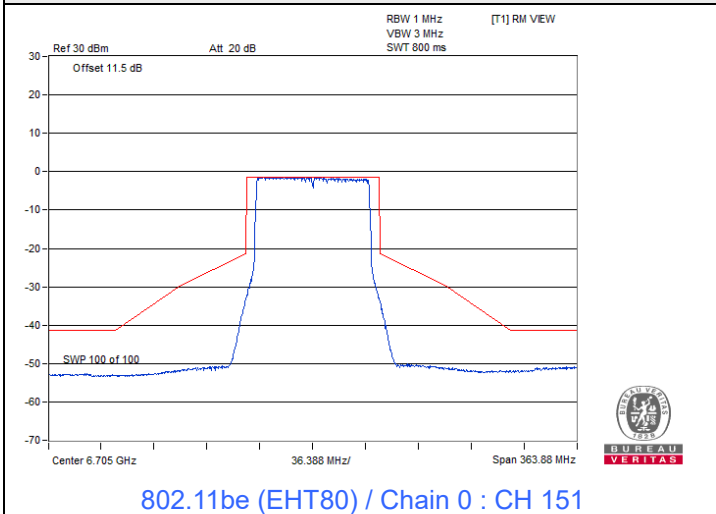

Spectrum Plot

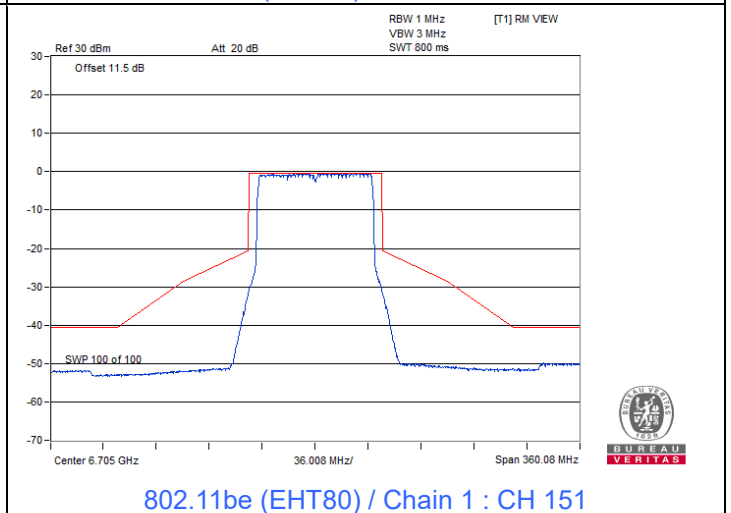
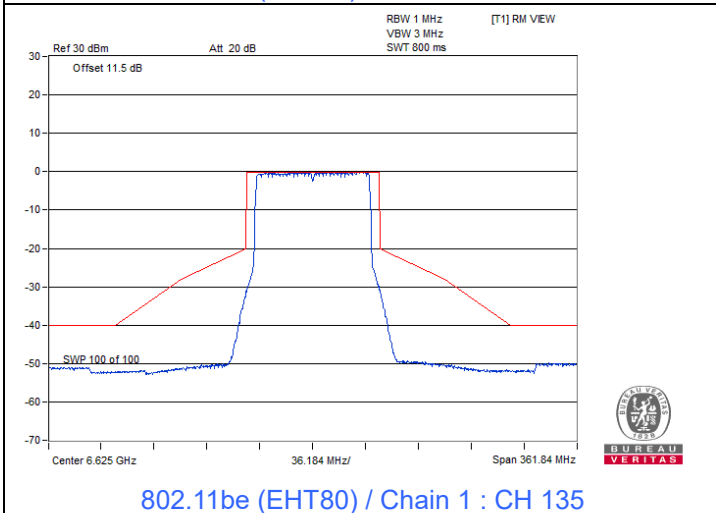
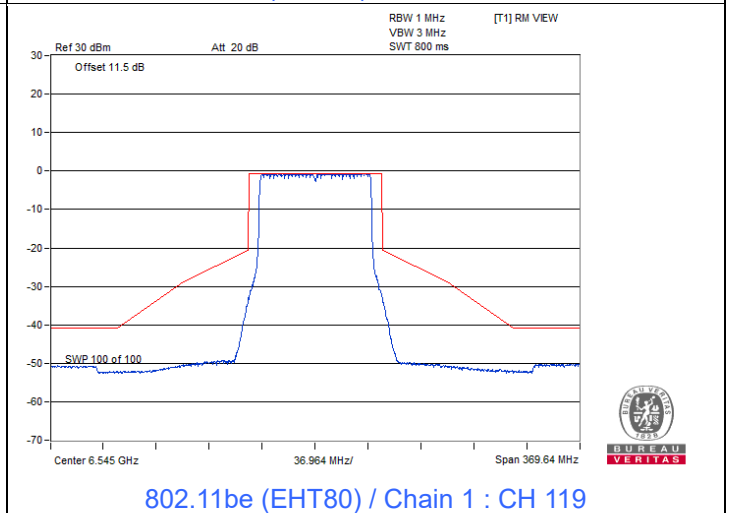
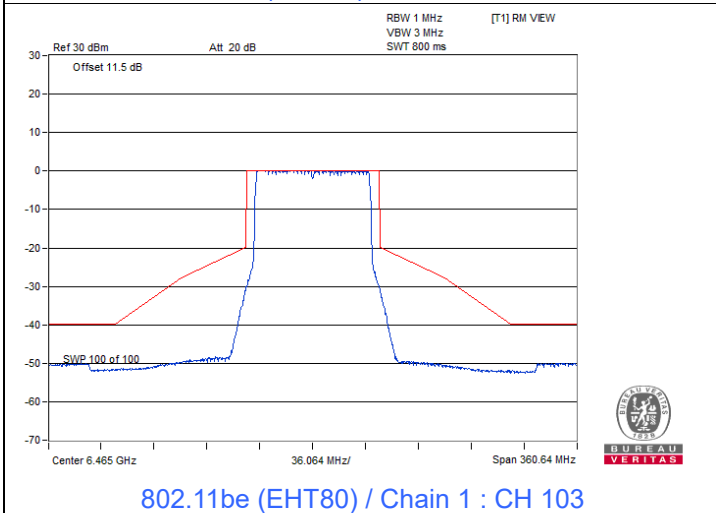
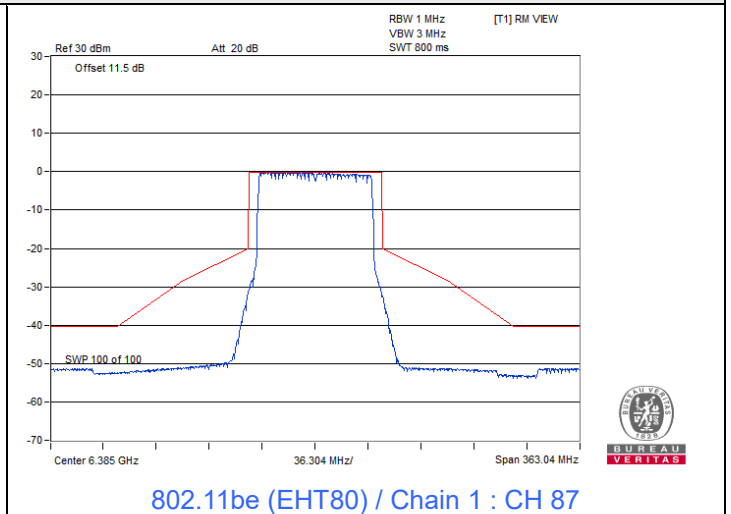
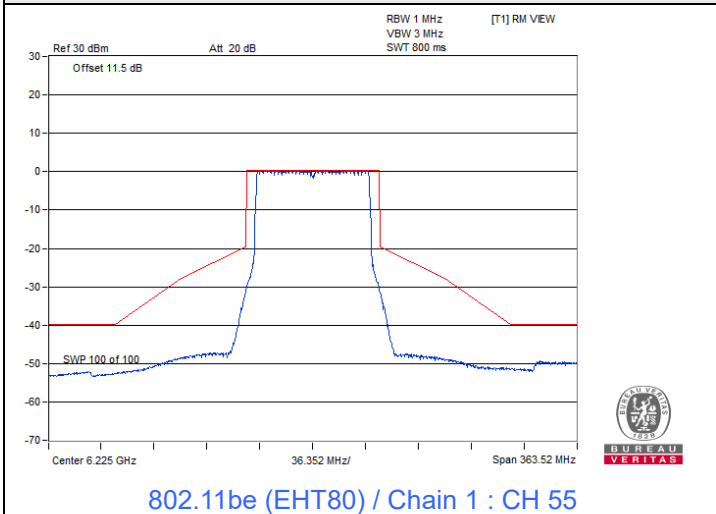

Spectrum Plot

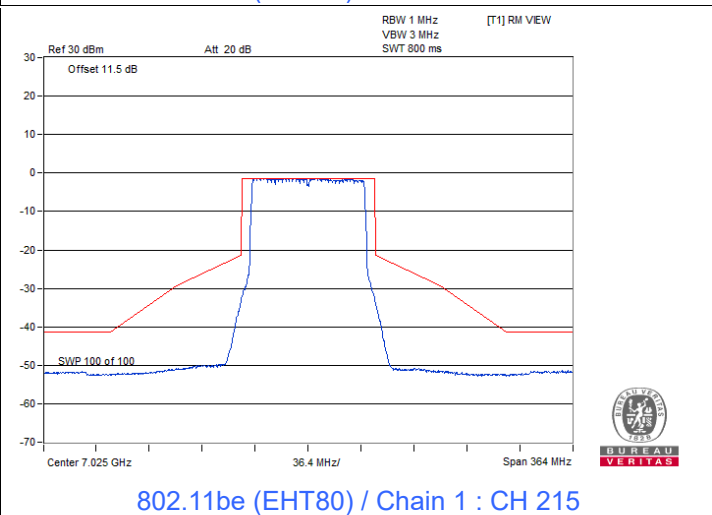
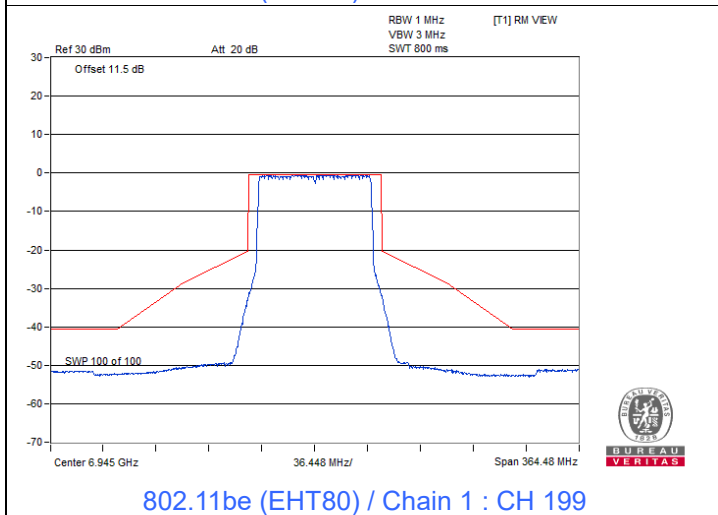
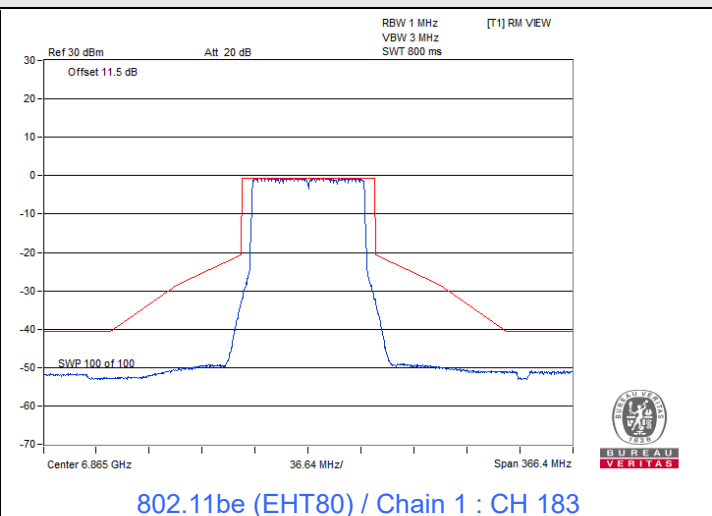
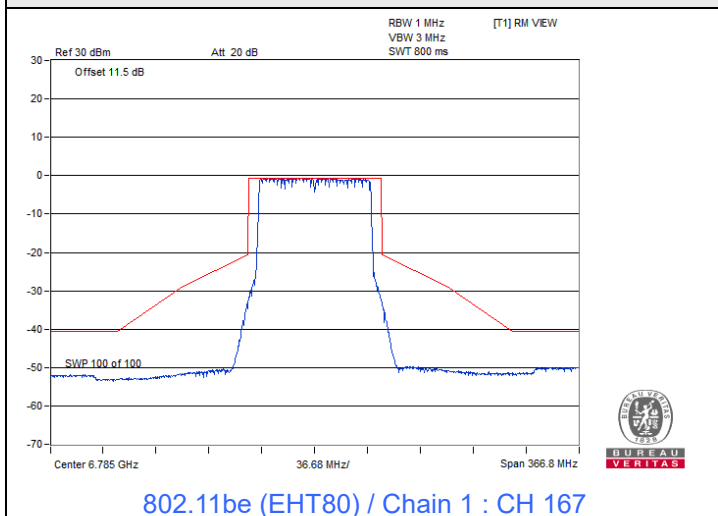



802.11be (EHT160)

Spectrum Plot

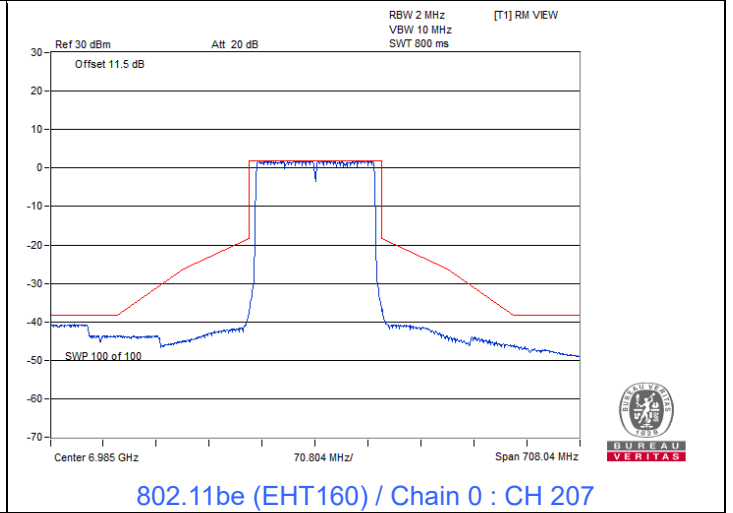
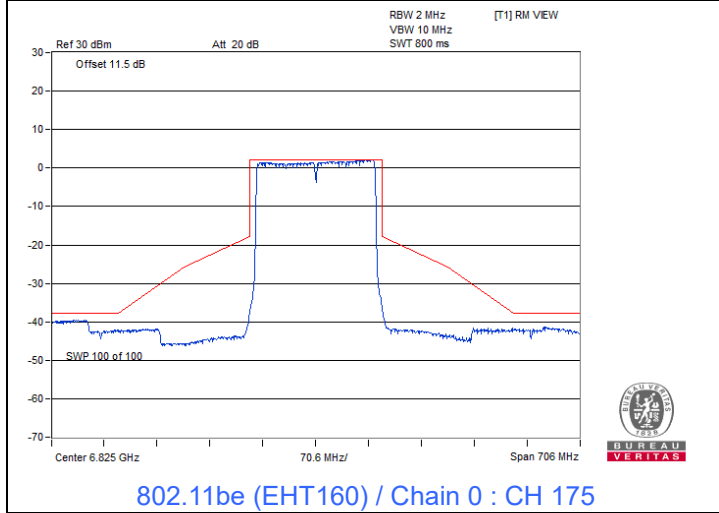
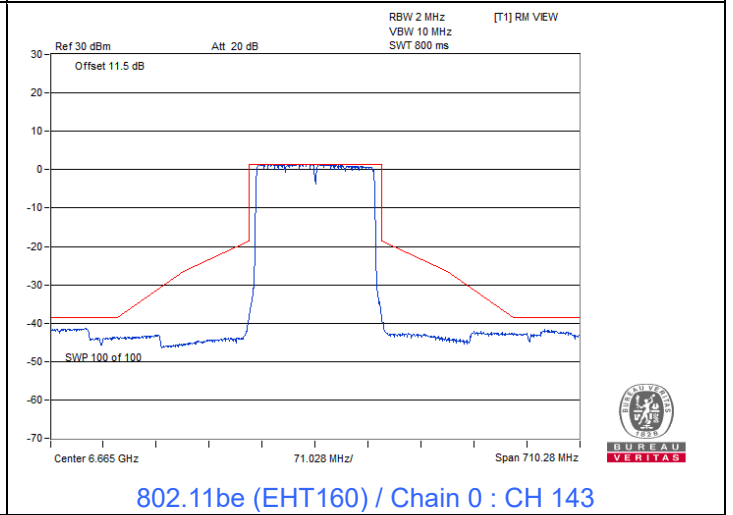
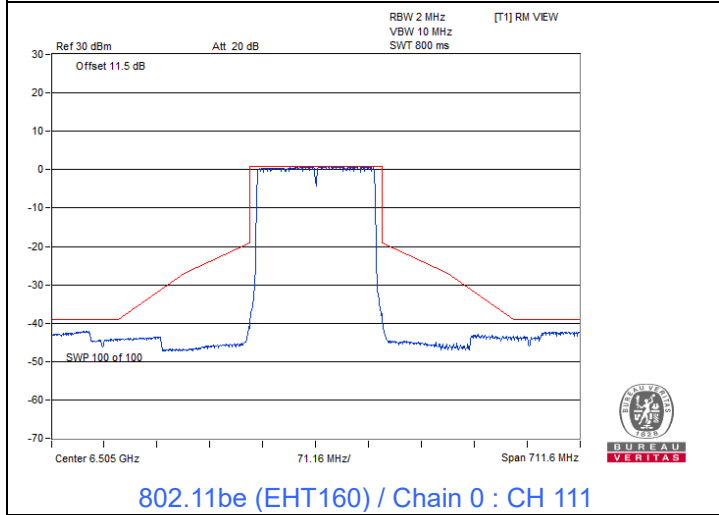
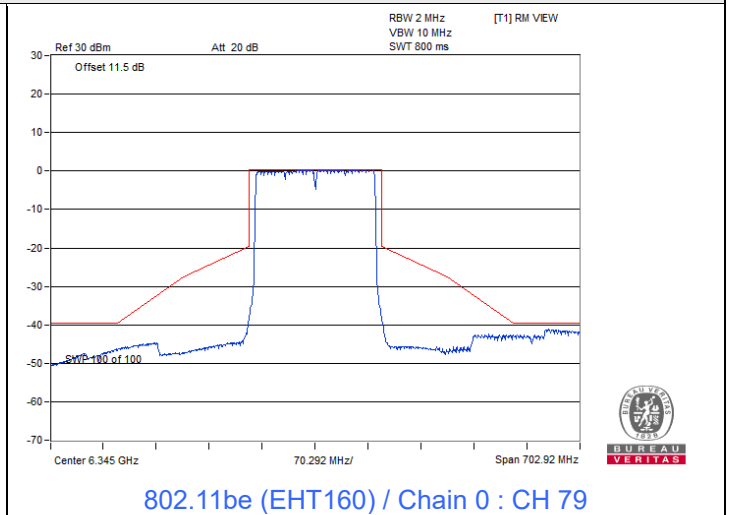
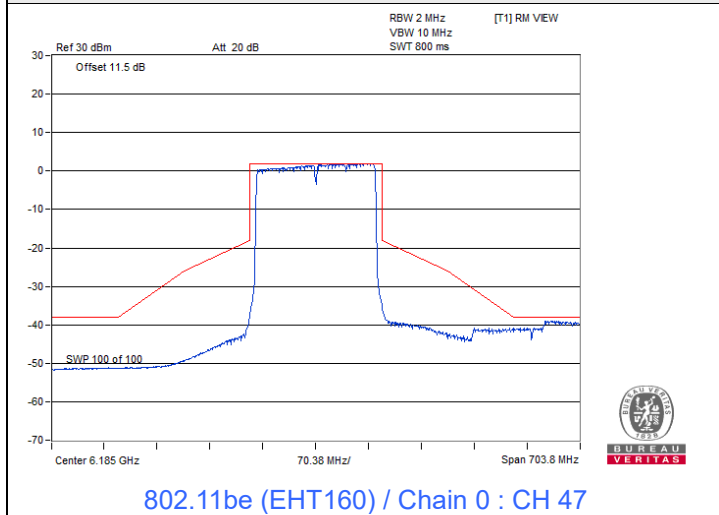

Spectrum Plot

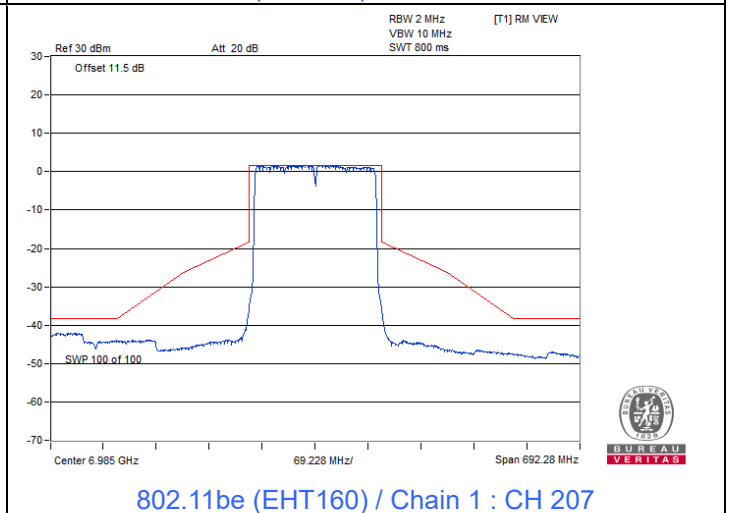
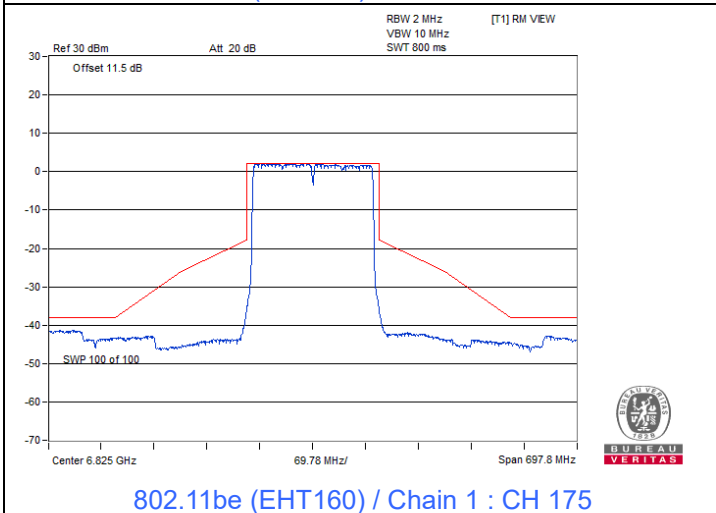
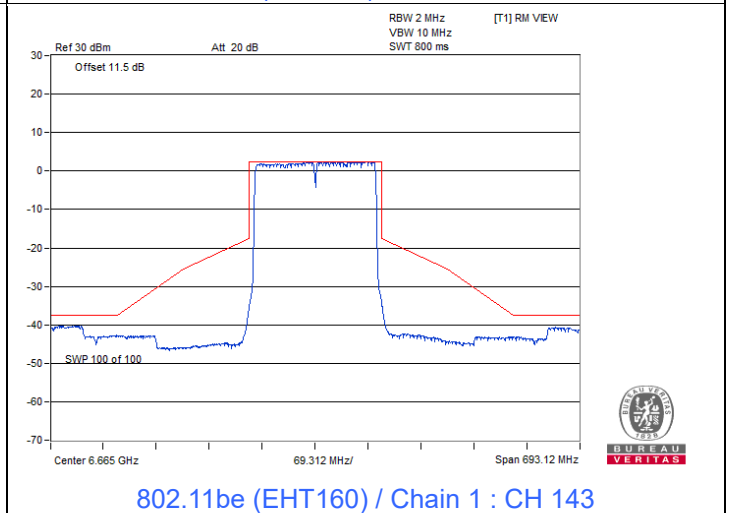
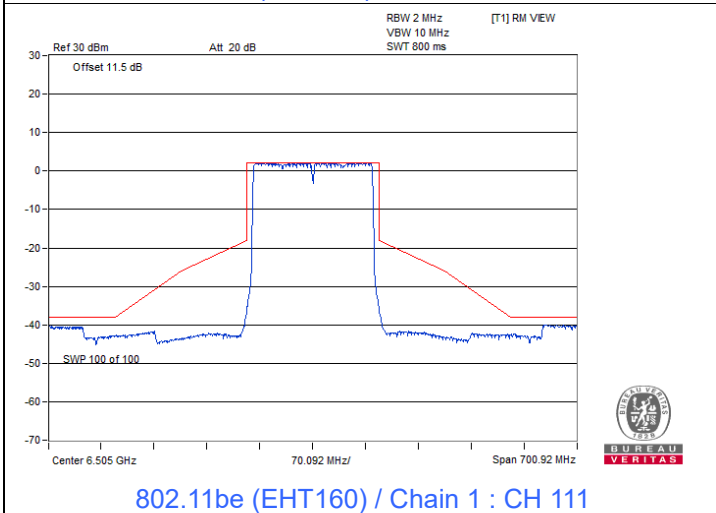
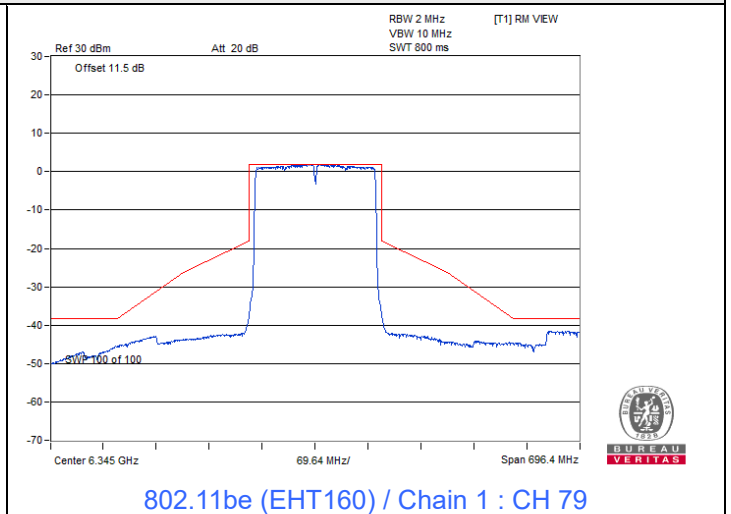
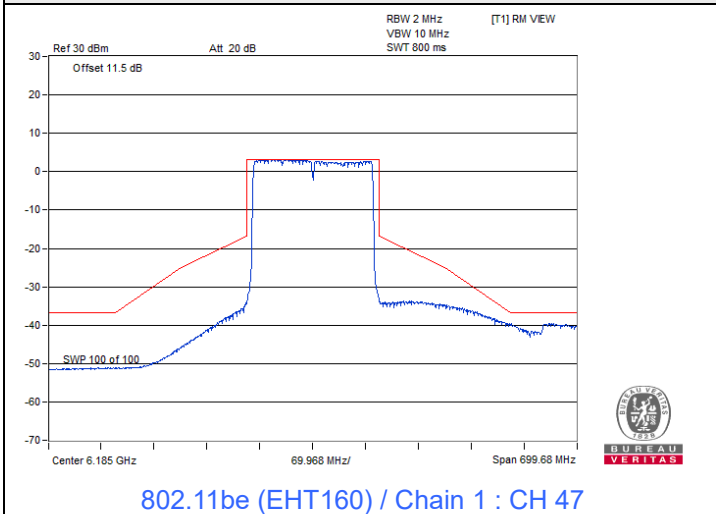



802.11be (EHT320)

Spectrum Plot

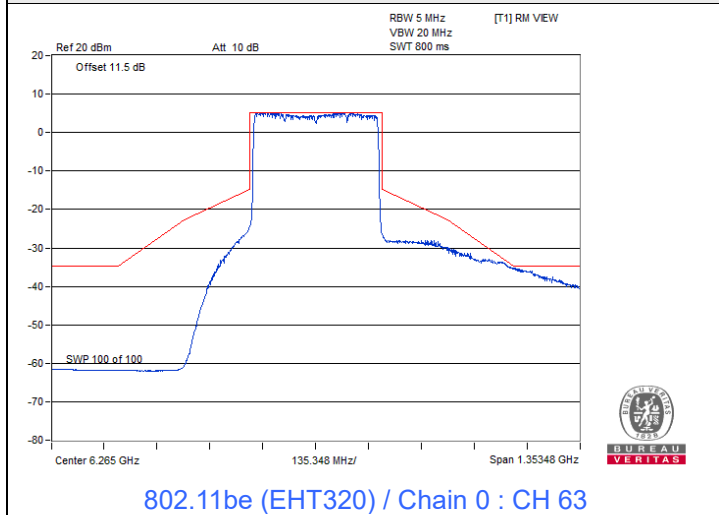

802.11be (EHT320) / Chain 0 : CH 63

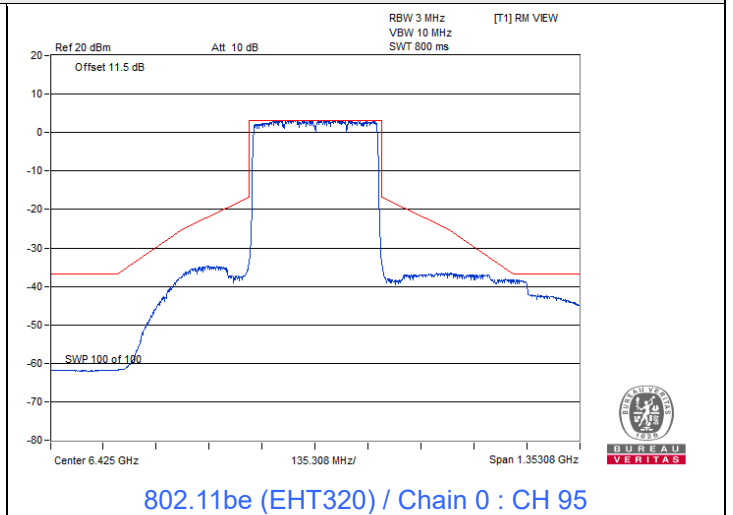

802.11be (EHT320) / Chain 0 : CH 95

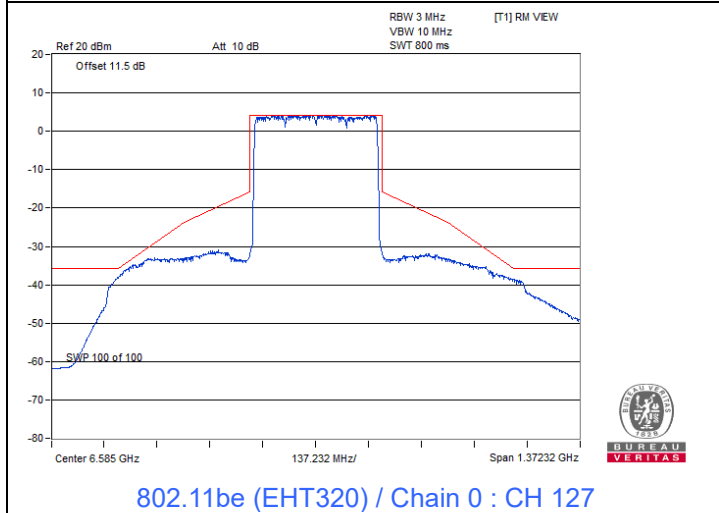

802.11be (EHT320) / Chain 0 : CH 127

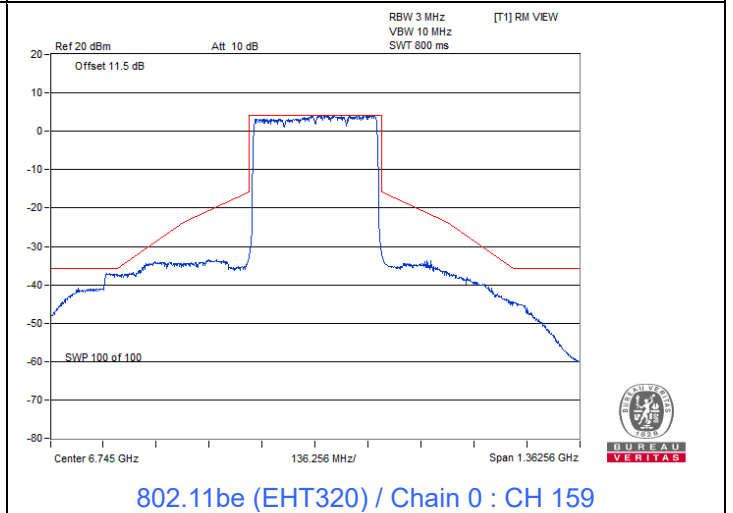

802.11be (EHT320) / Chain 0 : CH 159

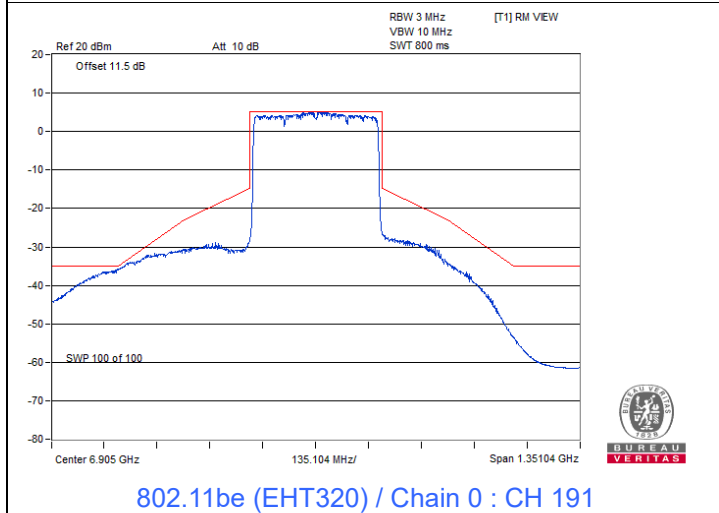

802.11be (EHT320) / Chain 0 : CH 191

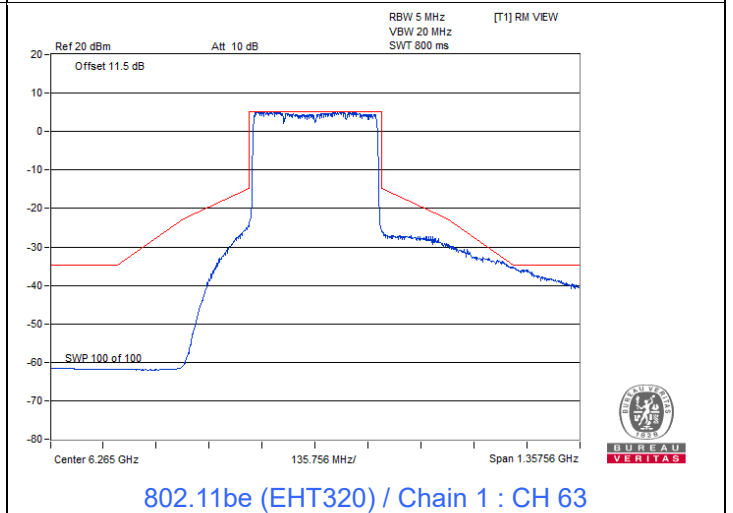

802.11be (EHT320) / Chain 1 : CH 63

Spectrum Plot

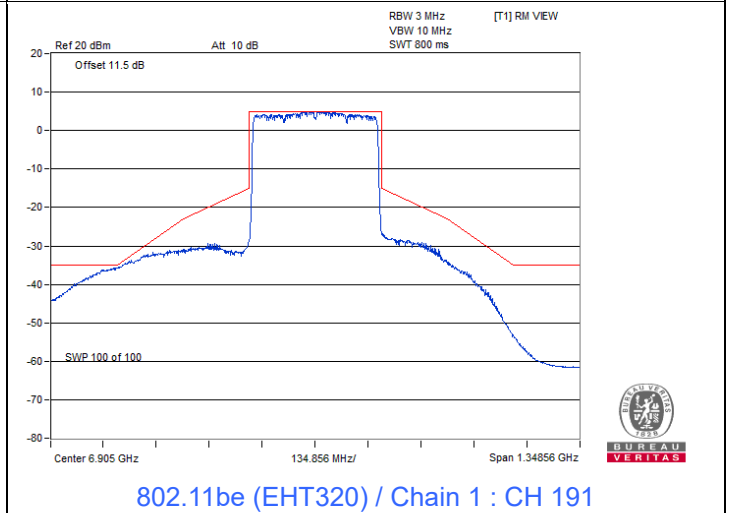
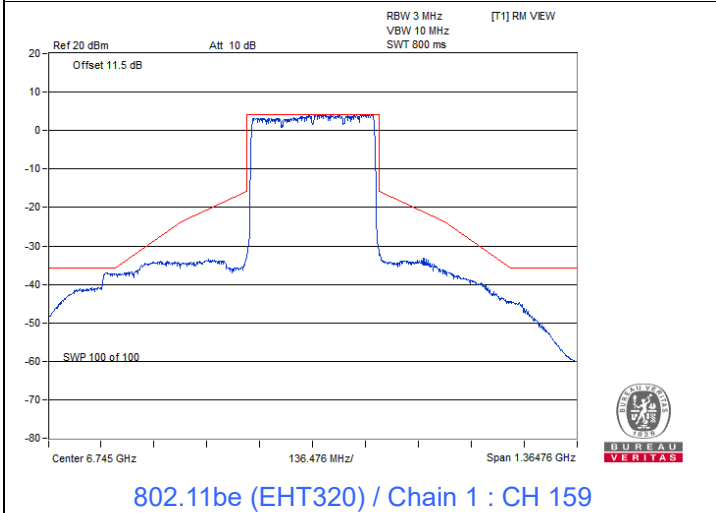
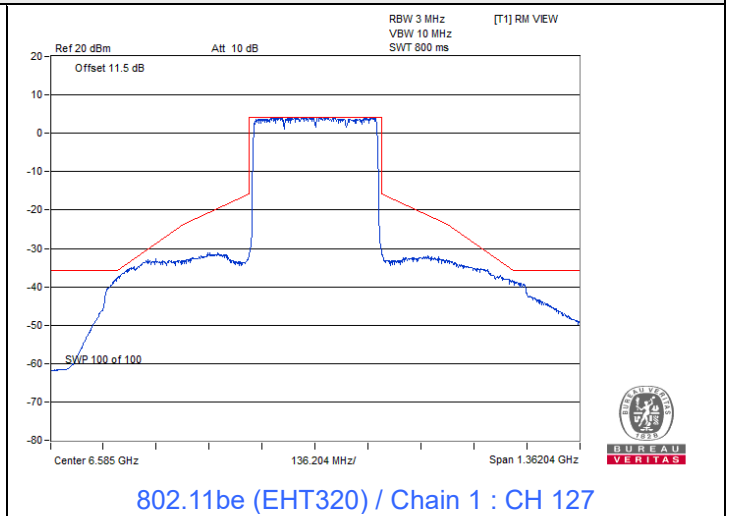
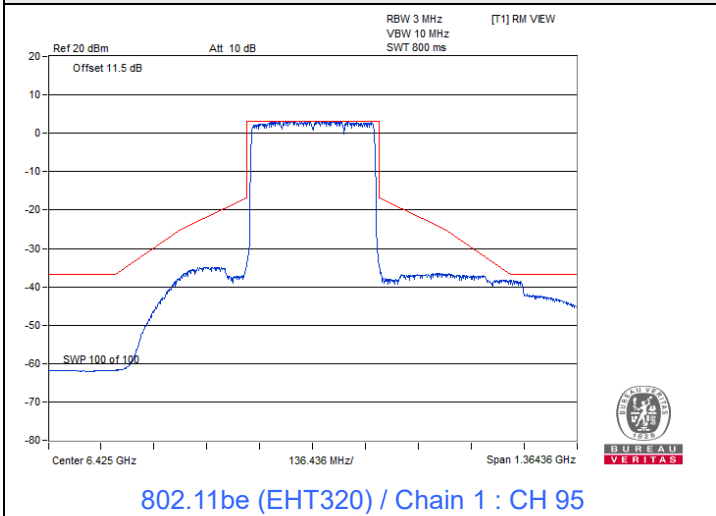

Beamforming (2T2S)

802.11be (EHT20)



Spectrum Plot

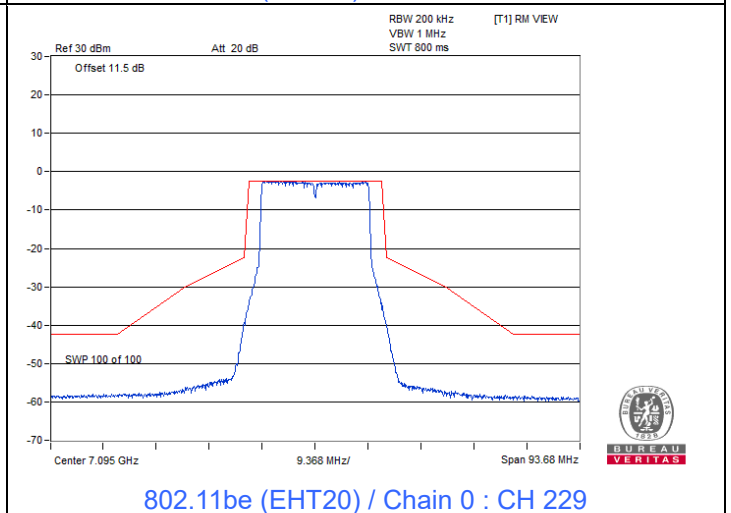
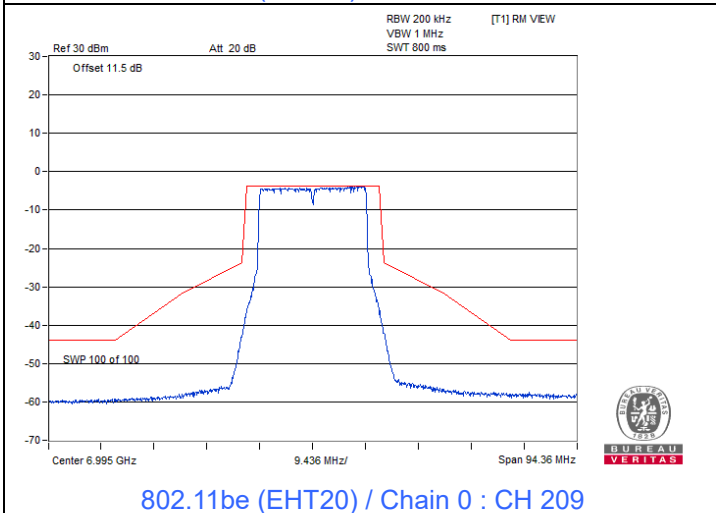
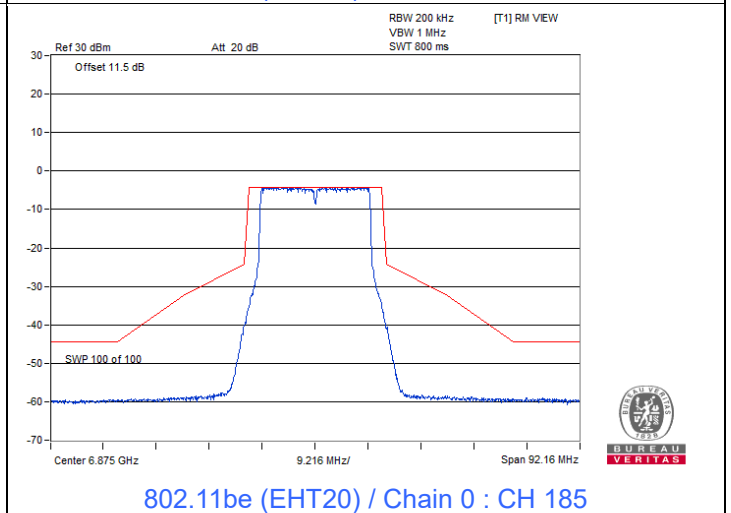
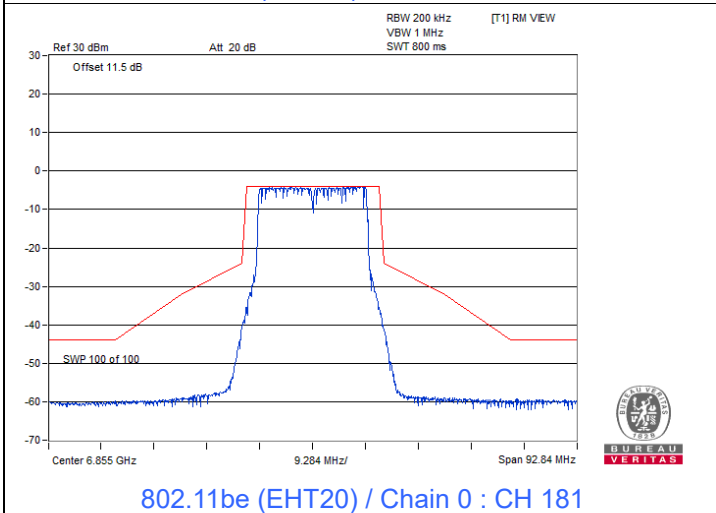
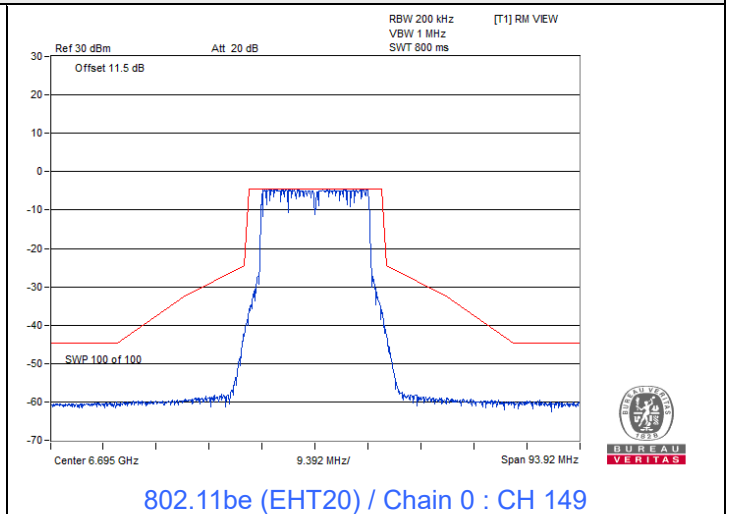
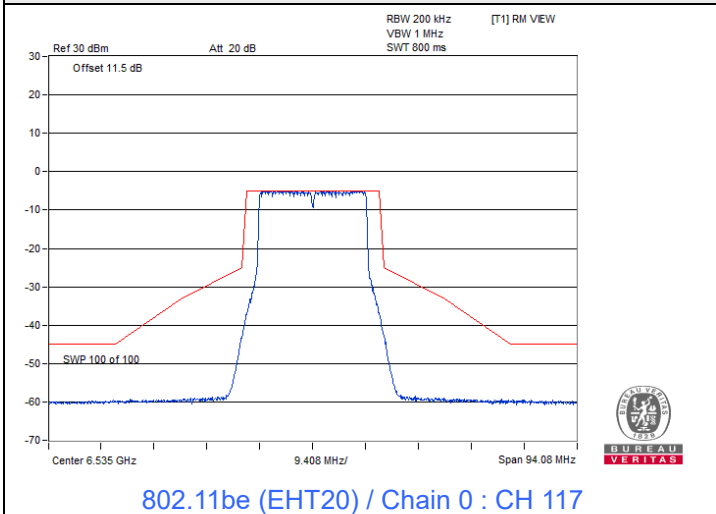

Spectrum Plot

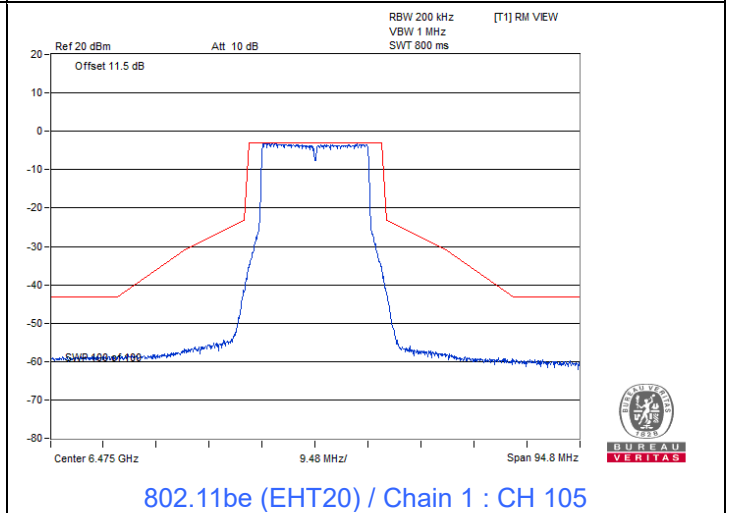
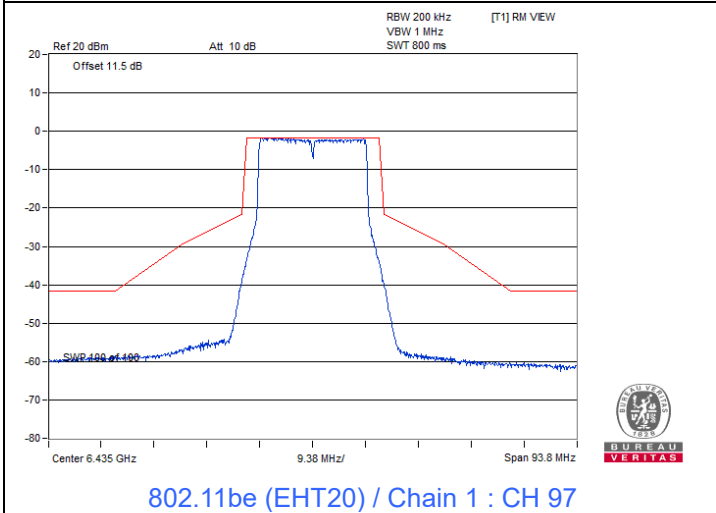
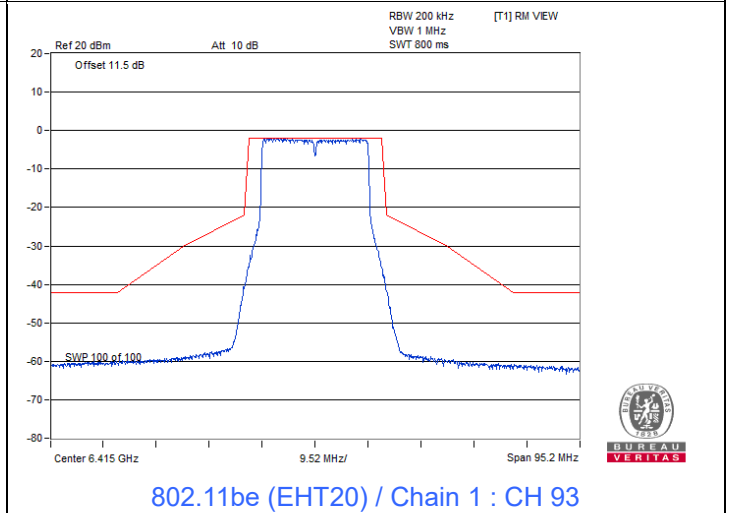
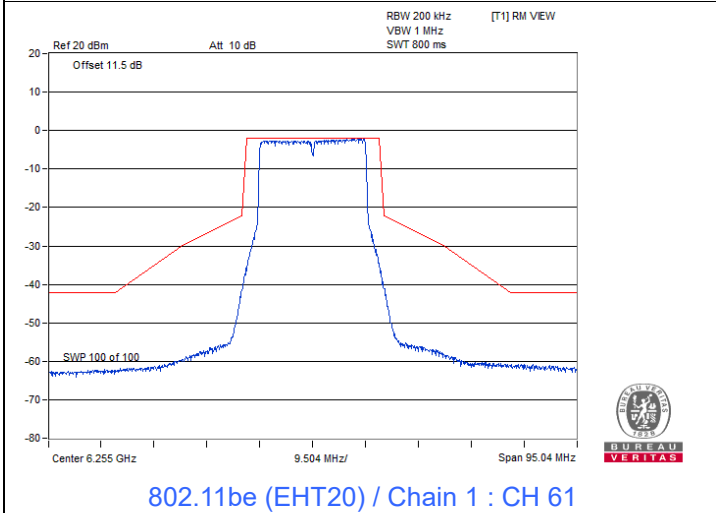
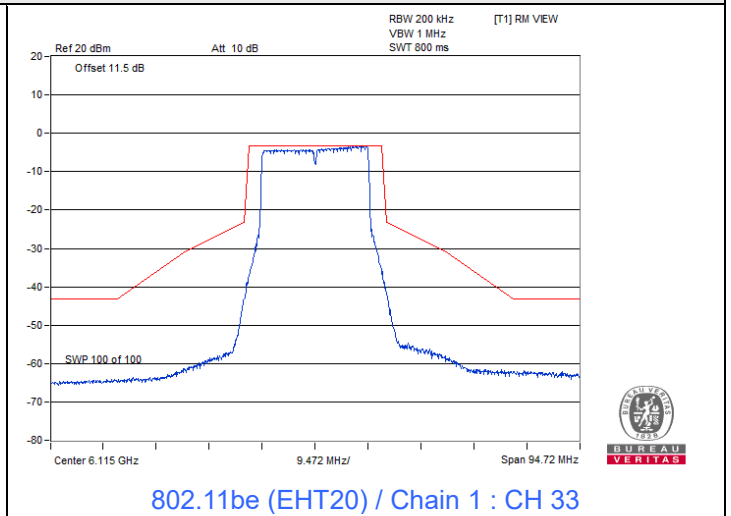
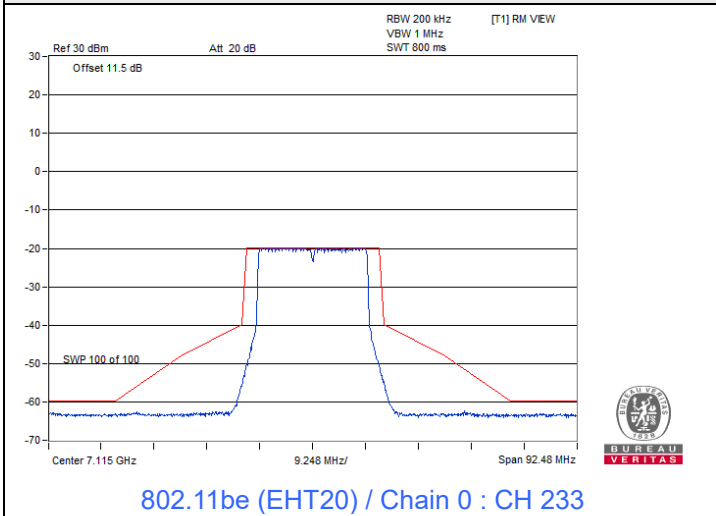

Spectrum Plot

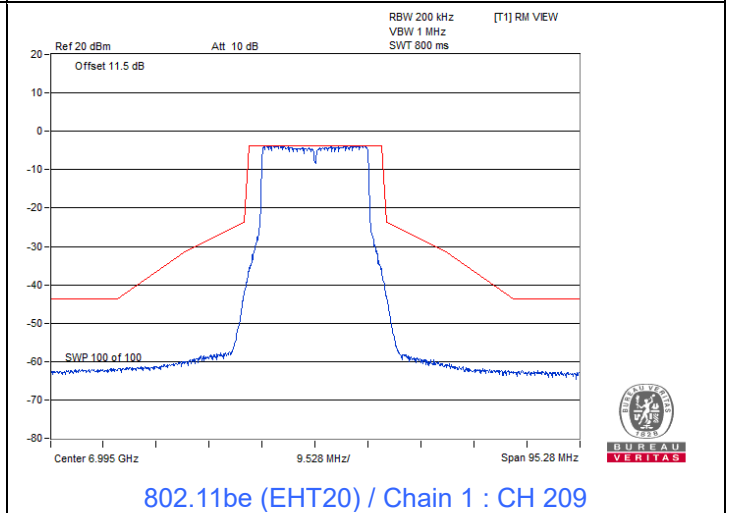
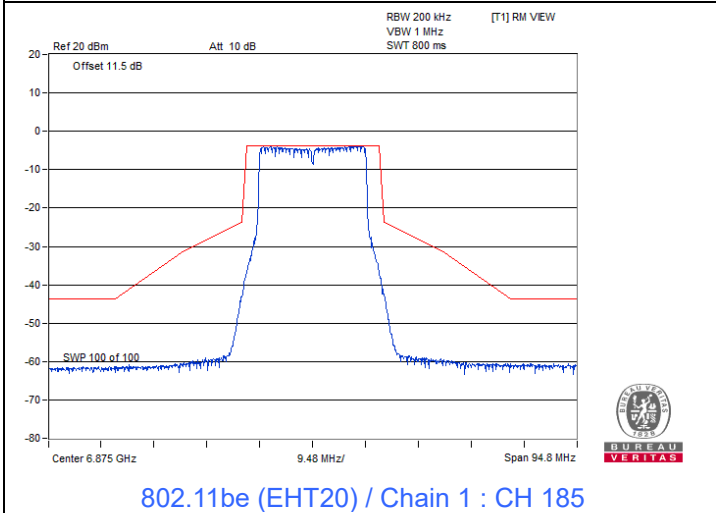
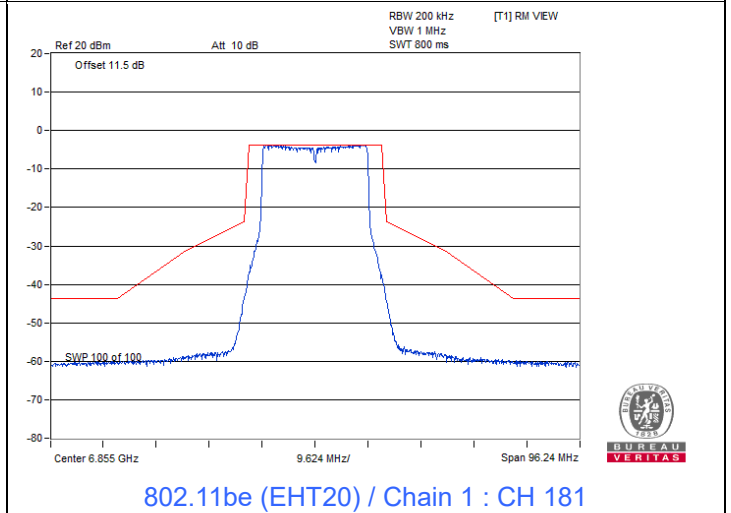
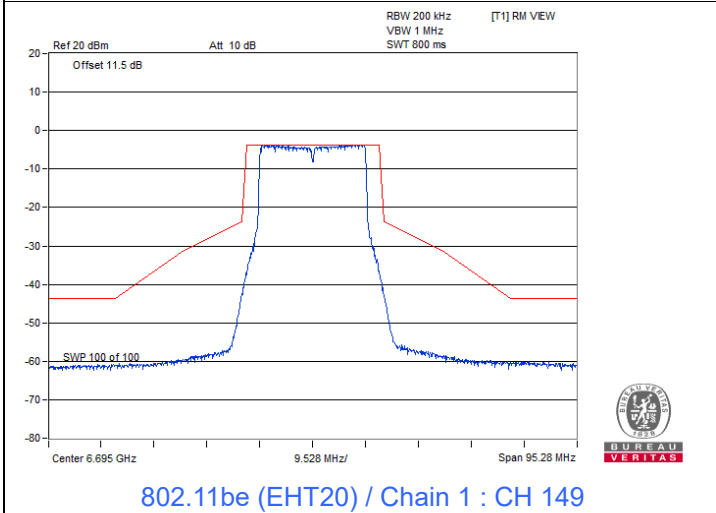
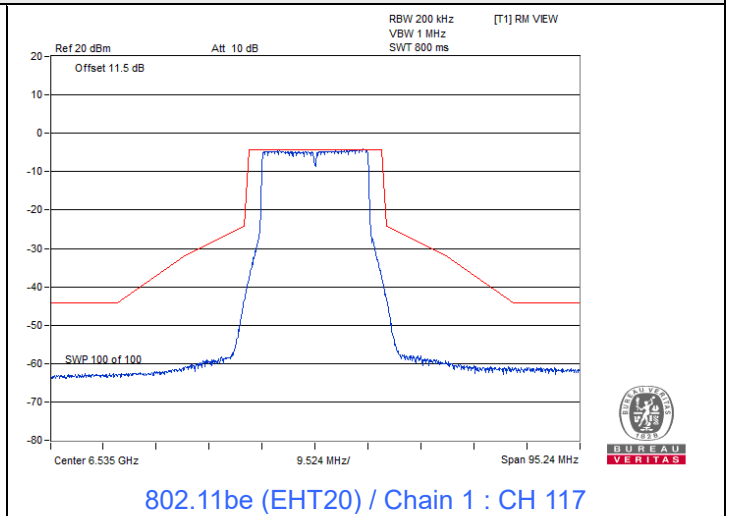
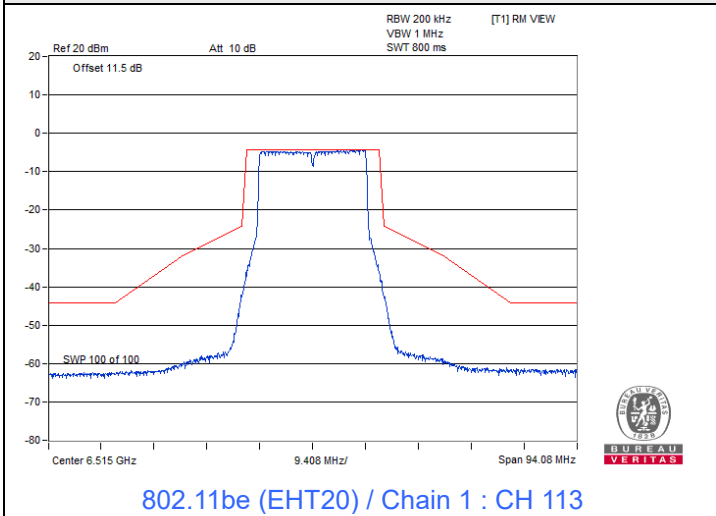

Spectrum Plot

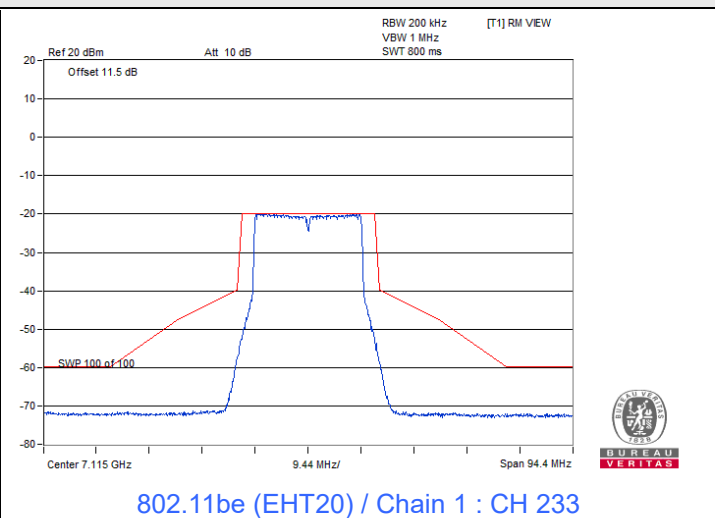
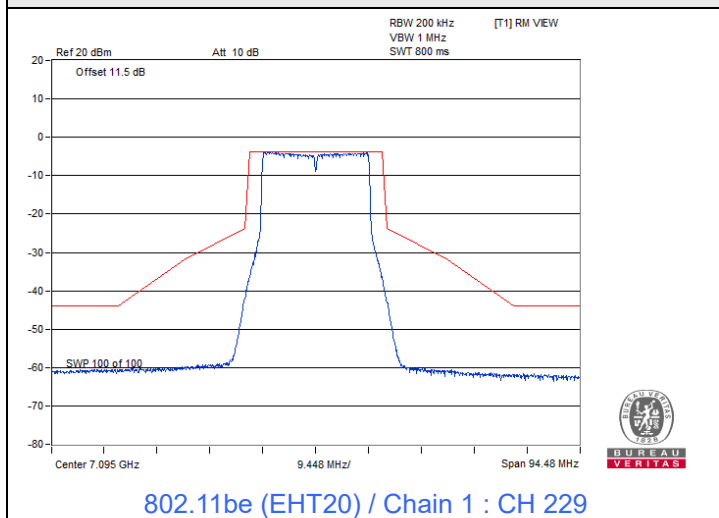



802.11be (EHT40)

Spectrum Plot

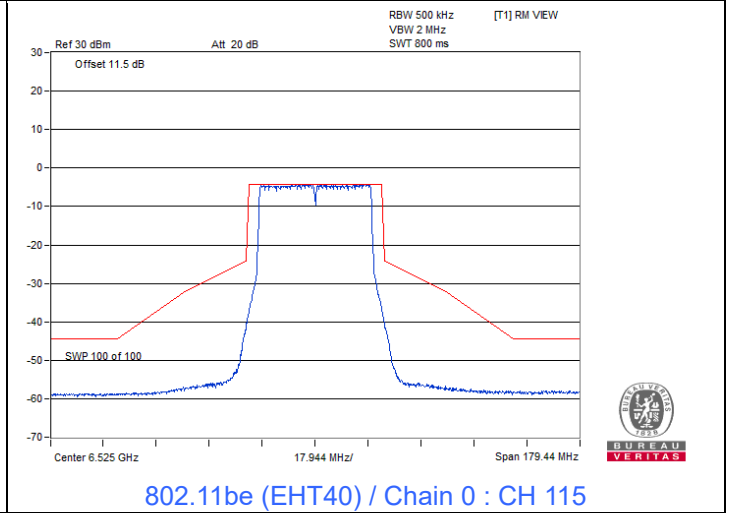
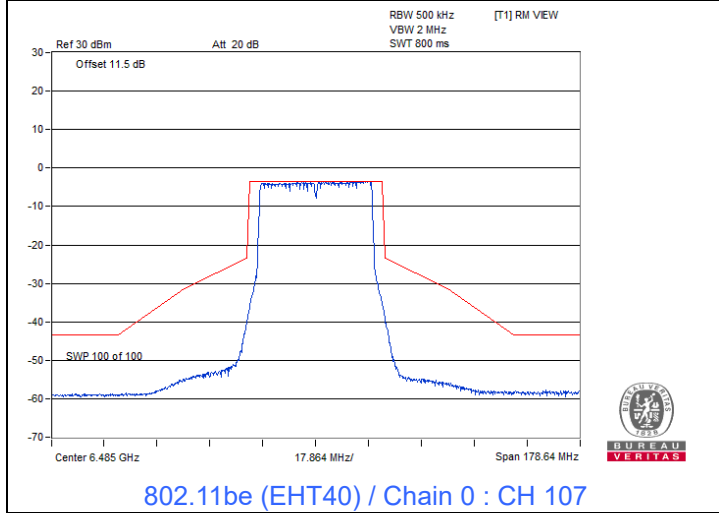
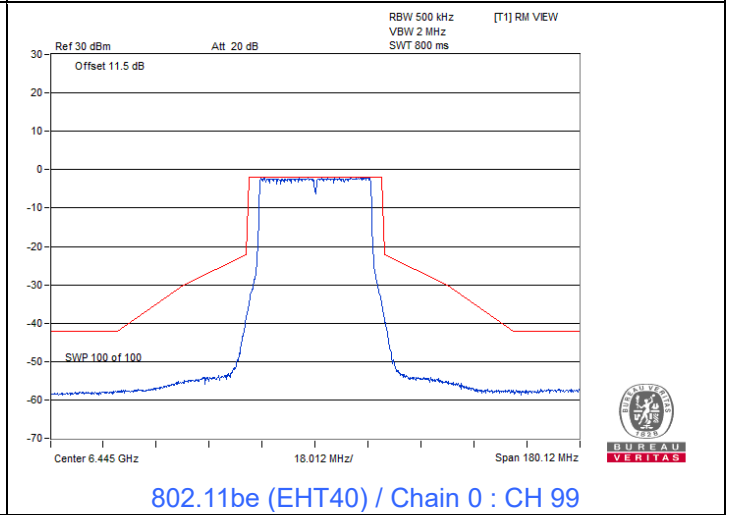
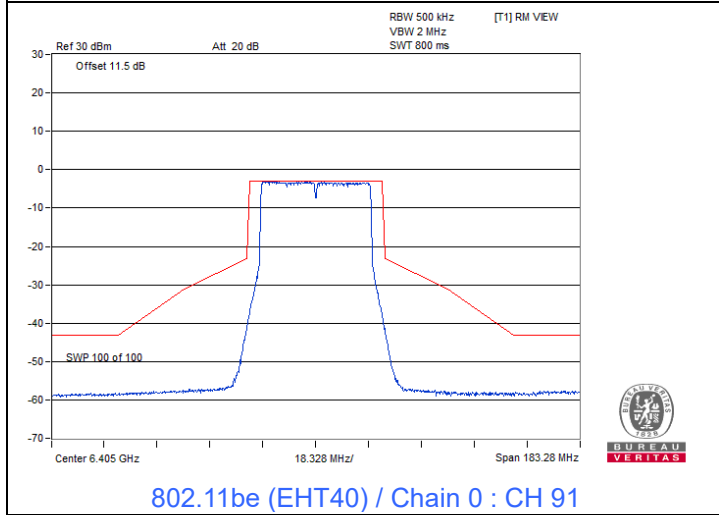
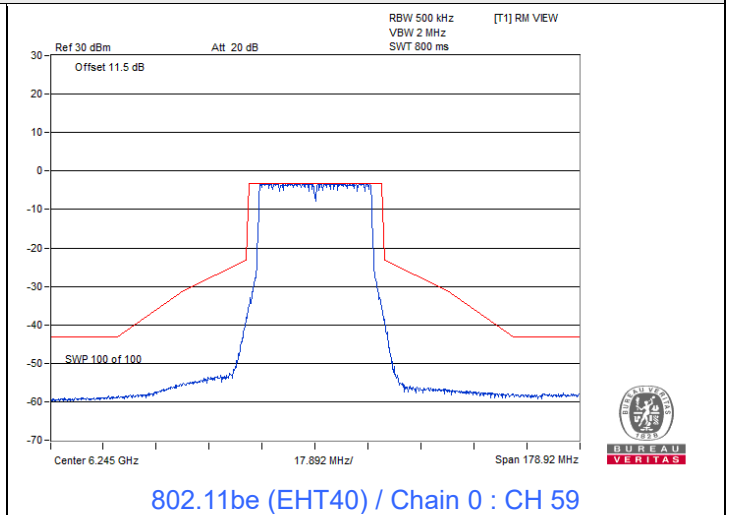
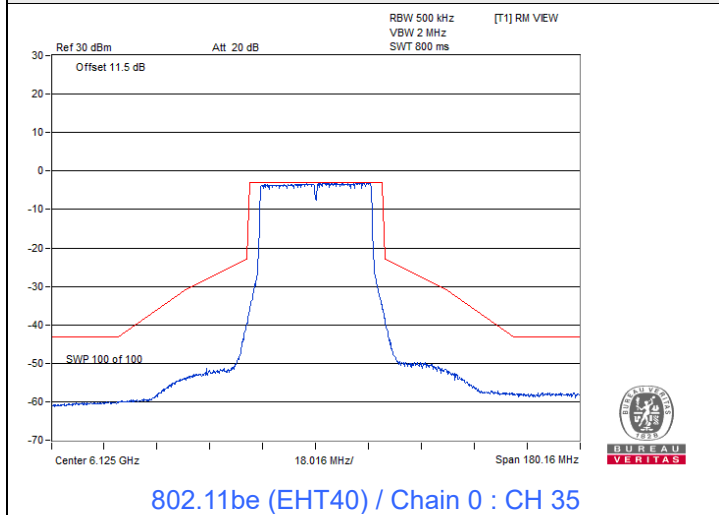

Spectrum Plot

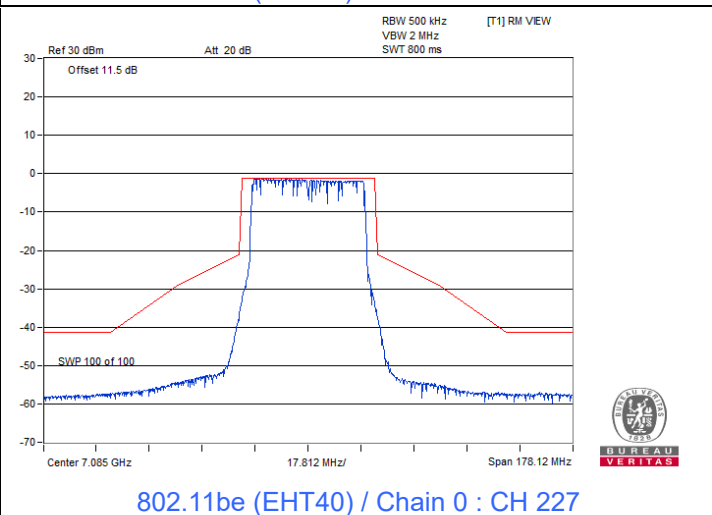
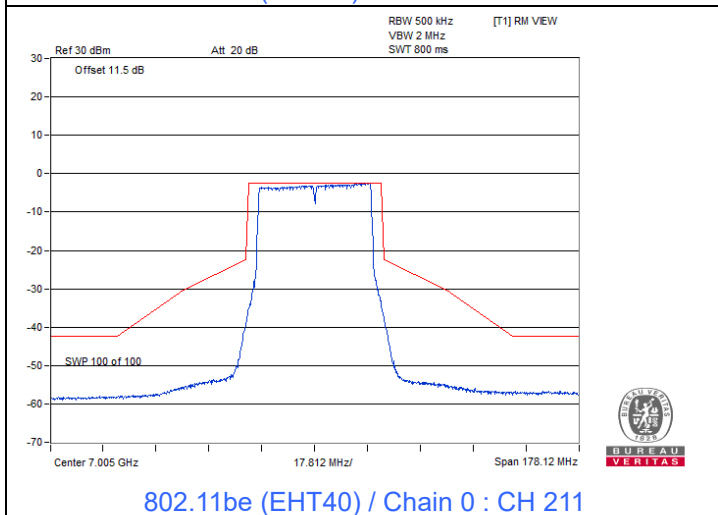
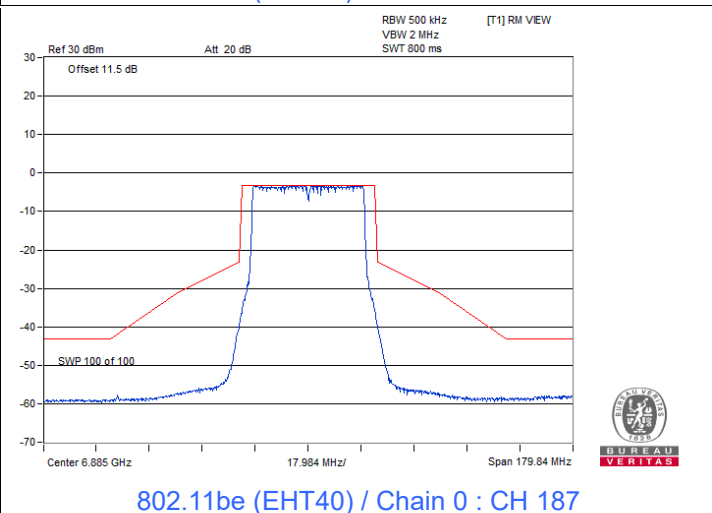
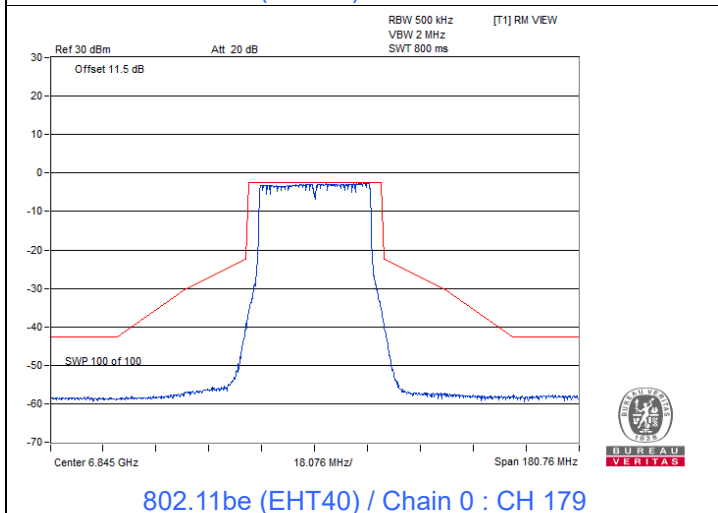
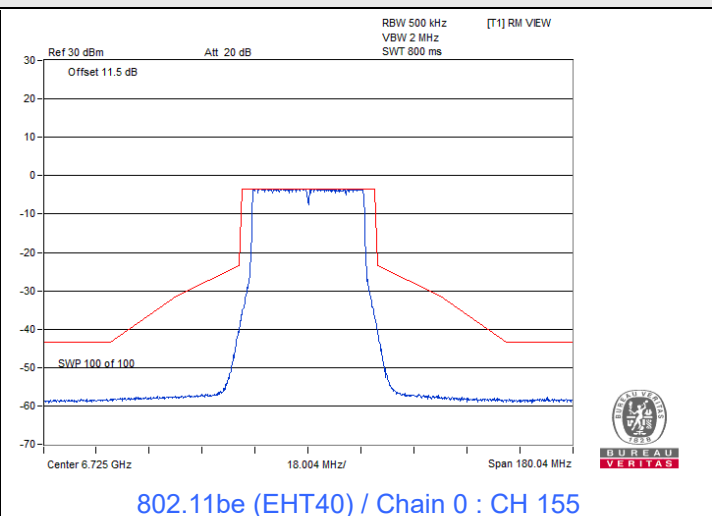
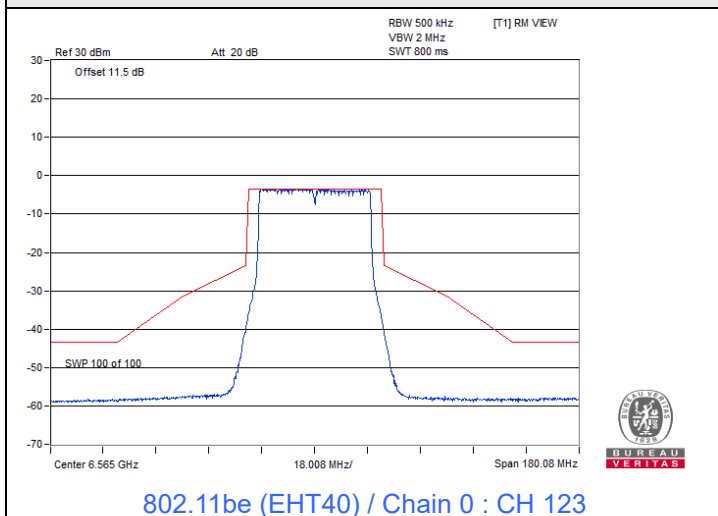

Spectrum Plot

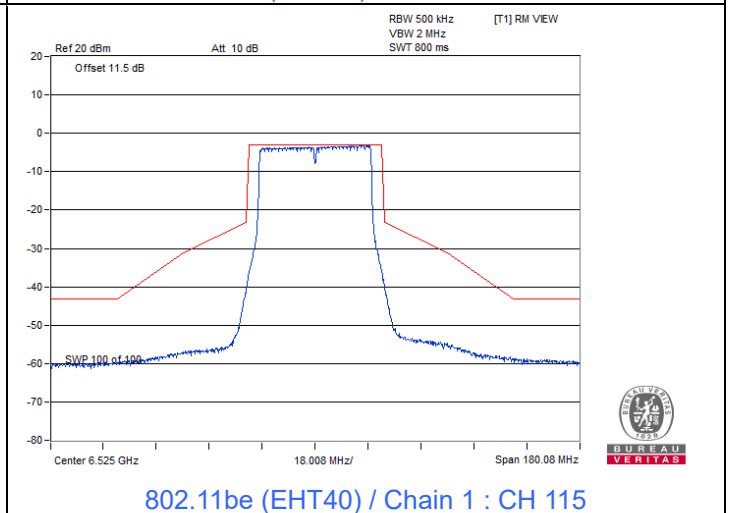
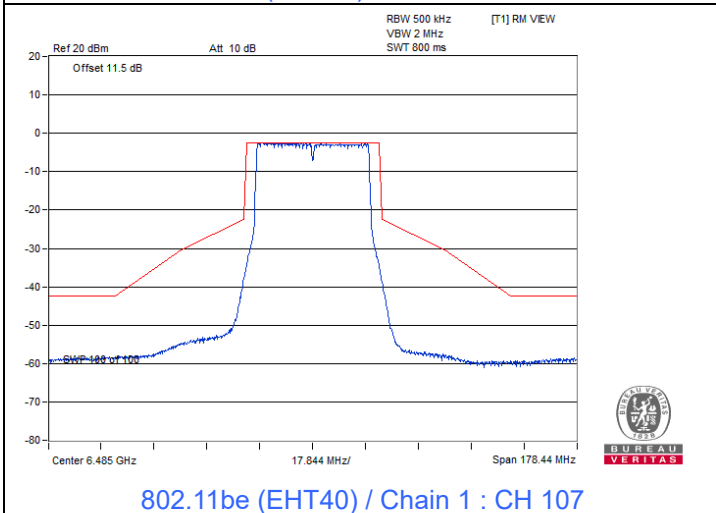
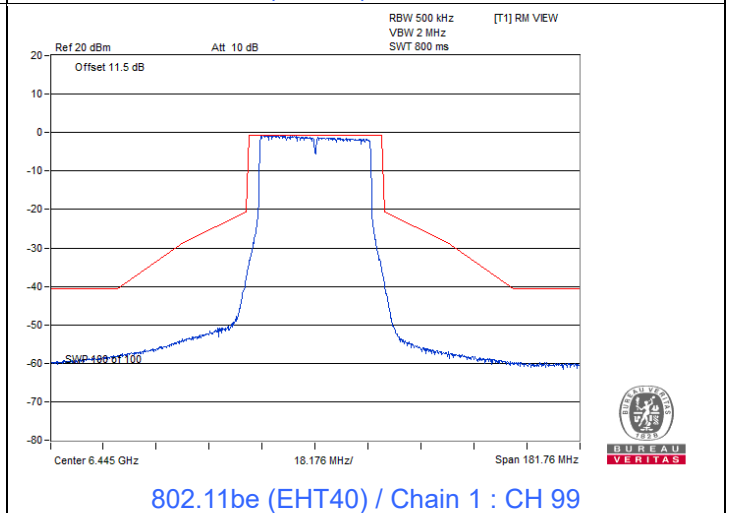
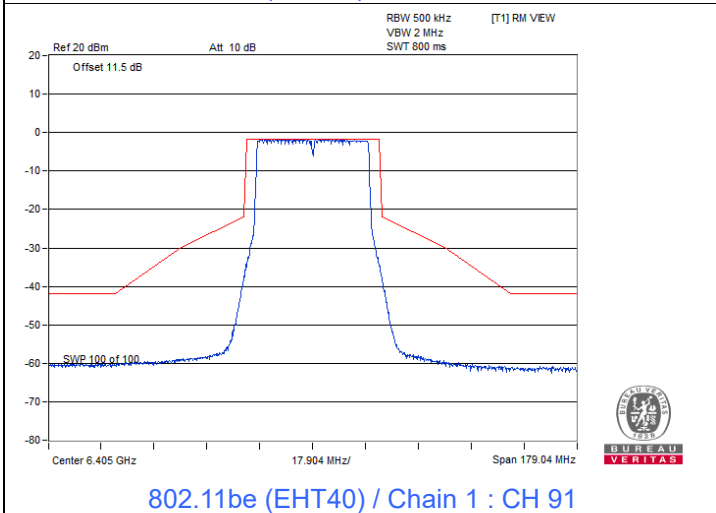
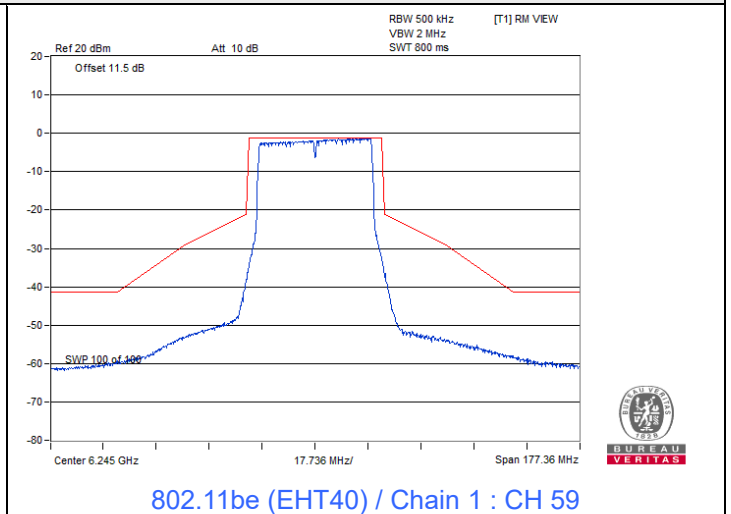
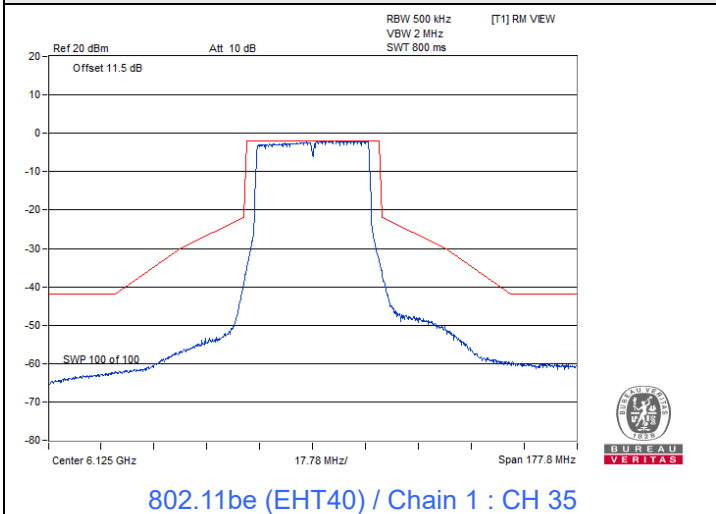



Spectrum Plot

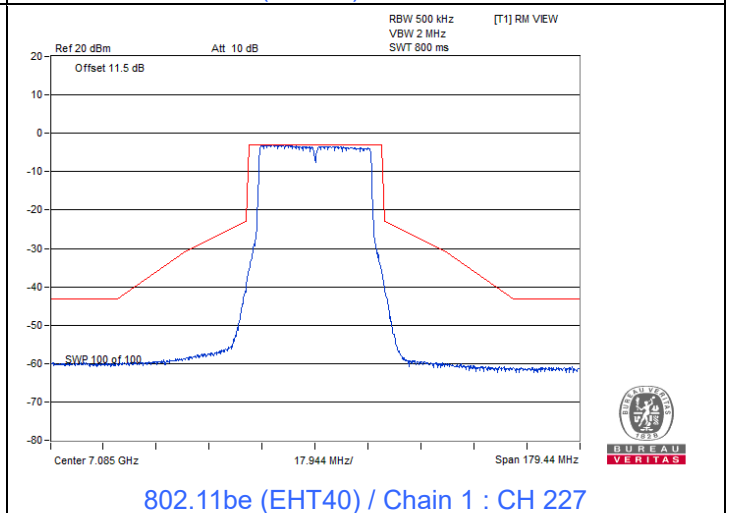
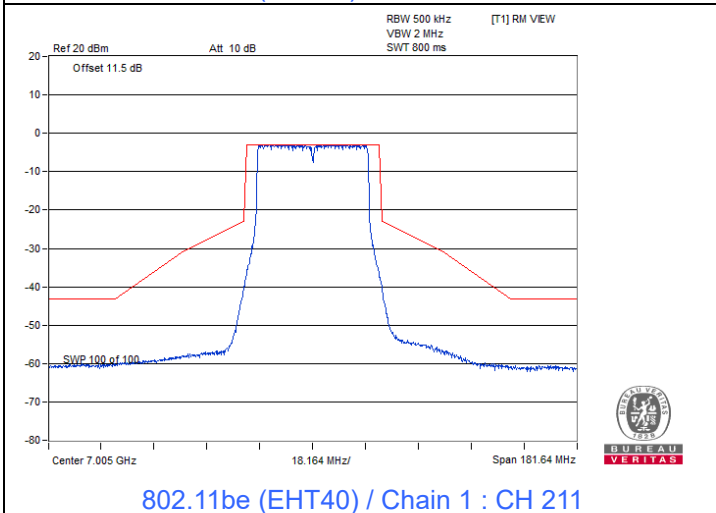
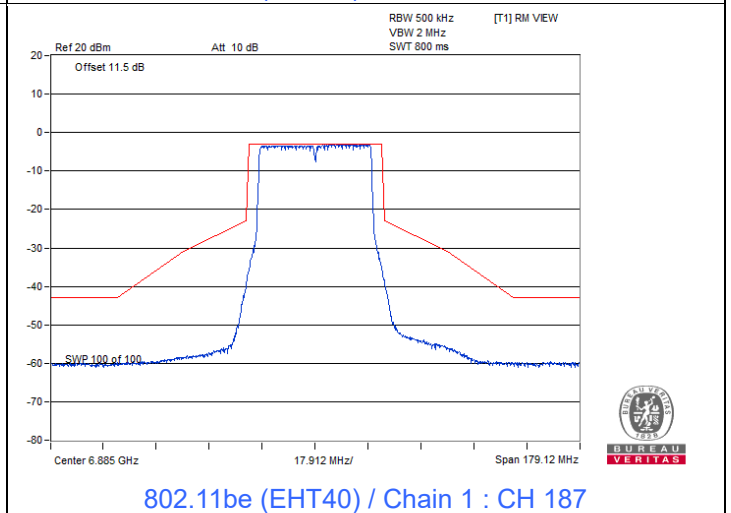
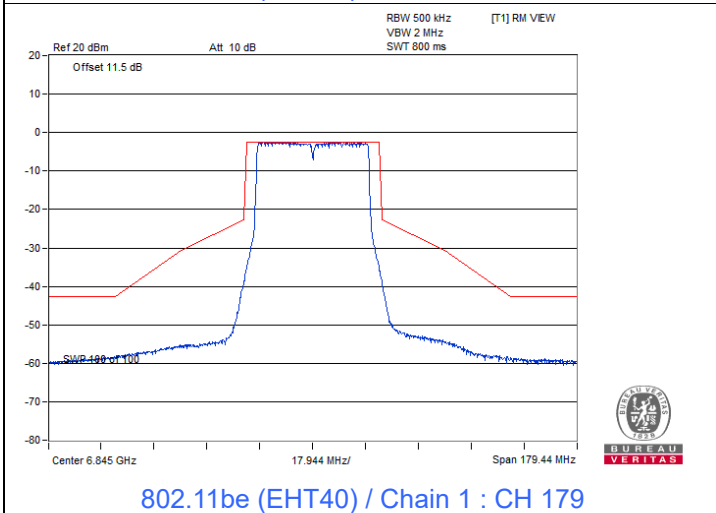
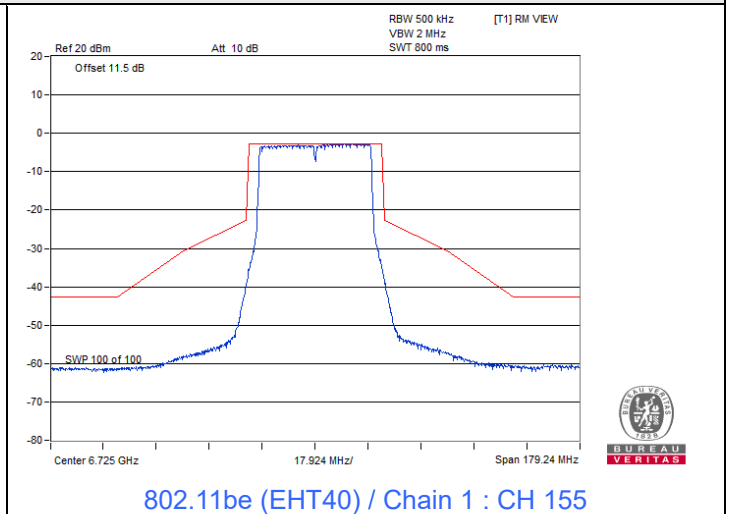
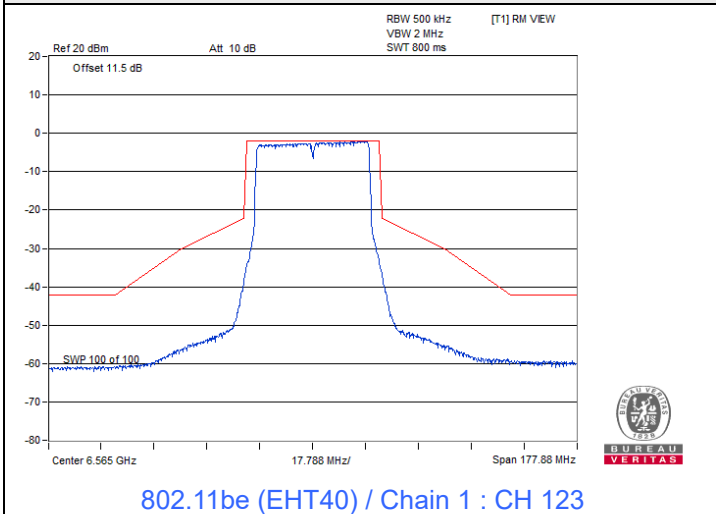



802.11be (EHT80)

Spectrum Plot

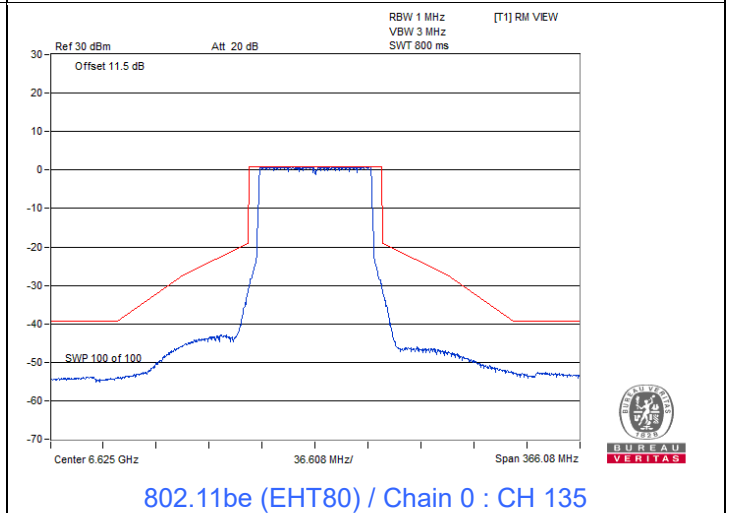
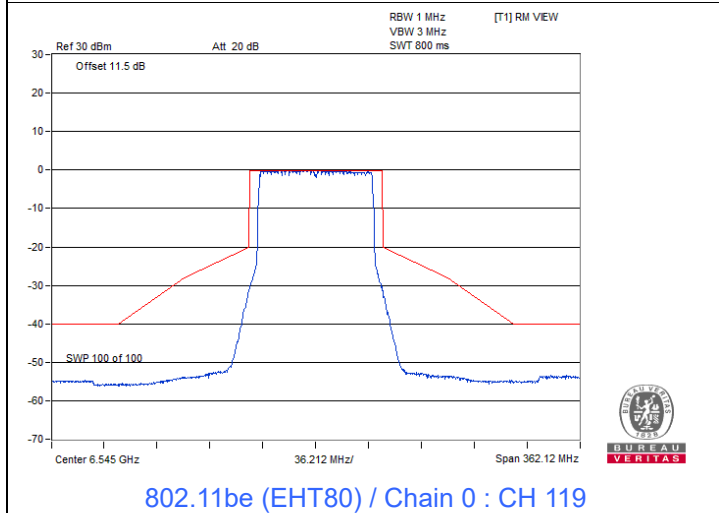
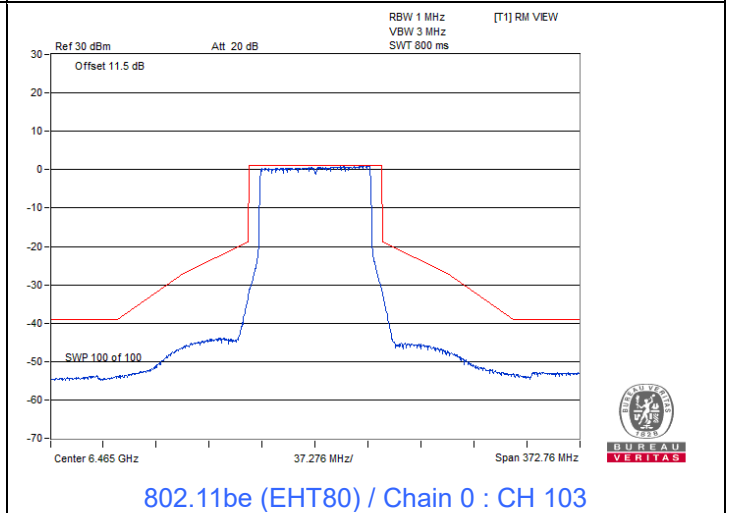
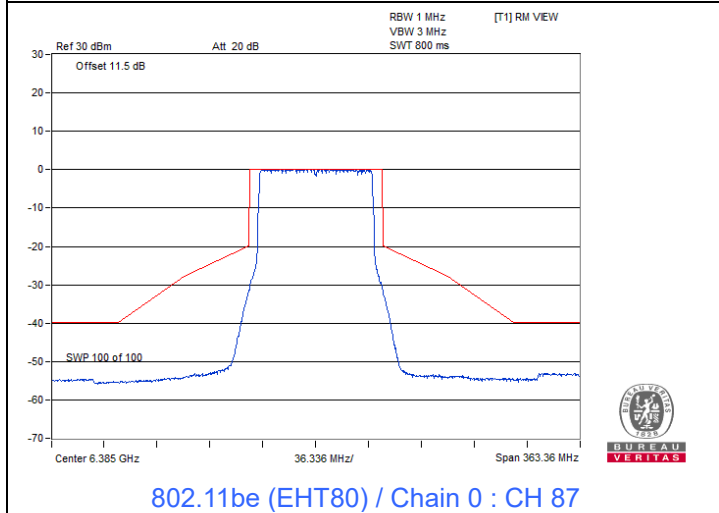
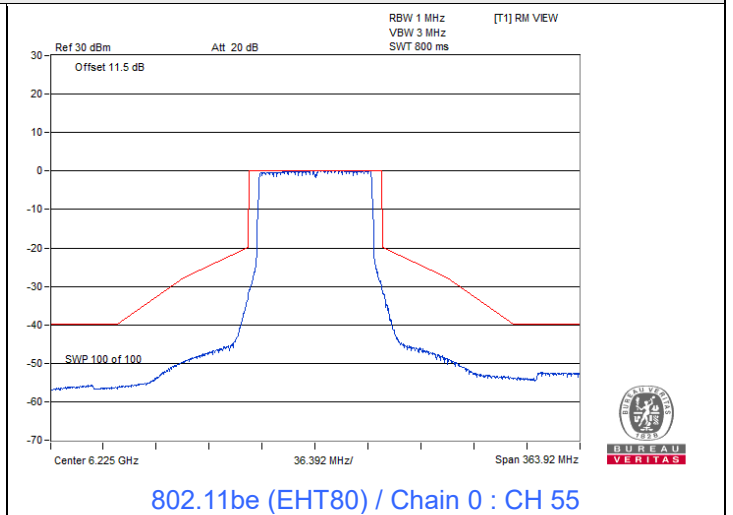
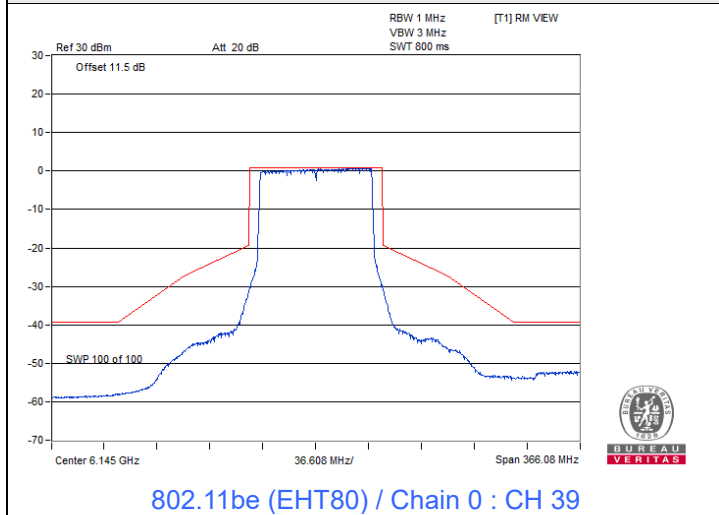

Spectrum Plot

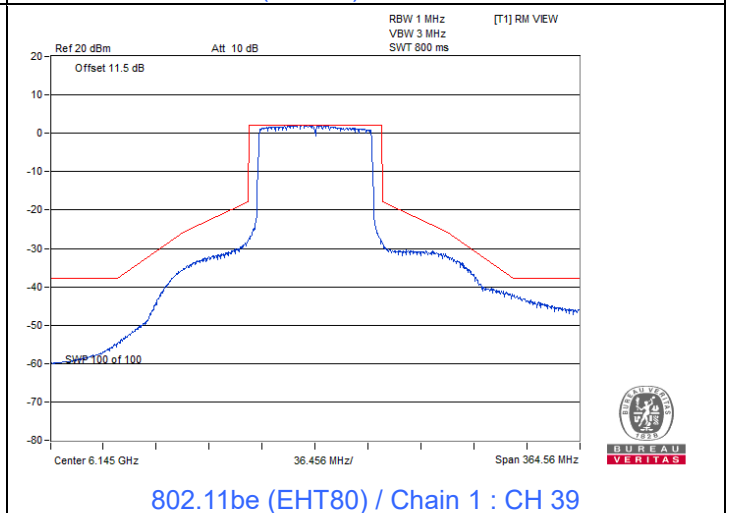
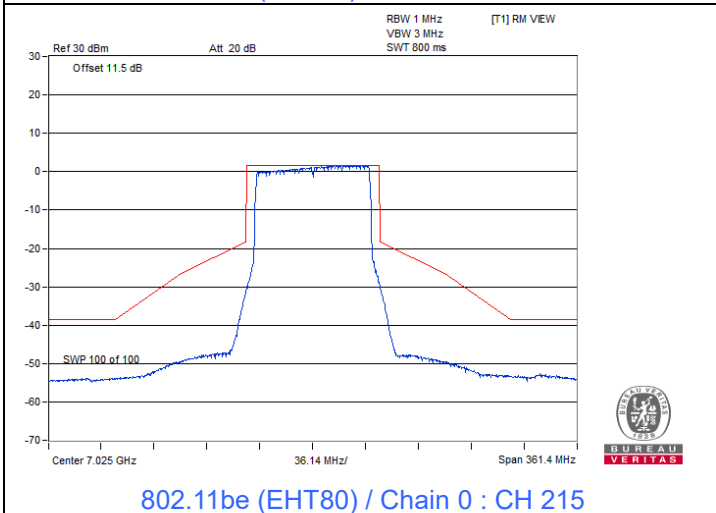
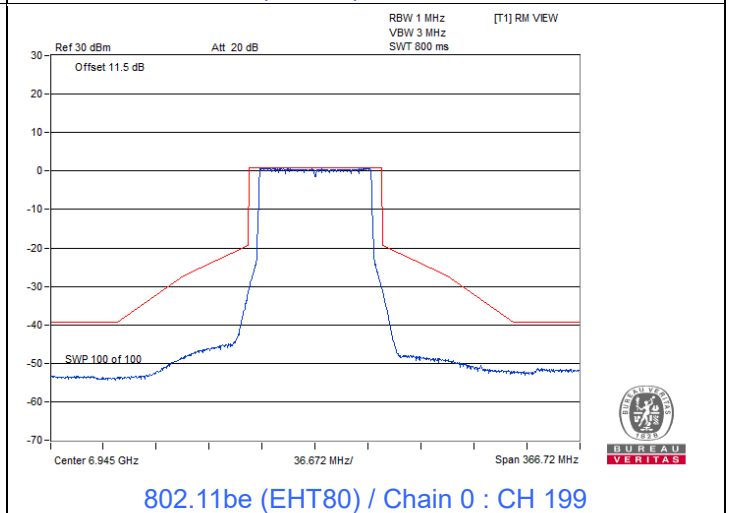
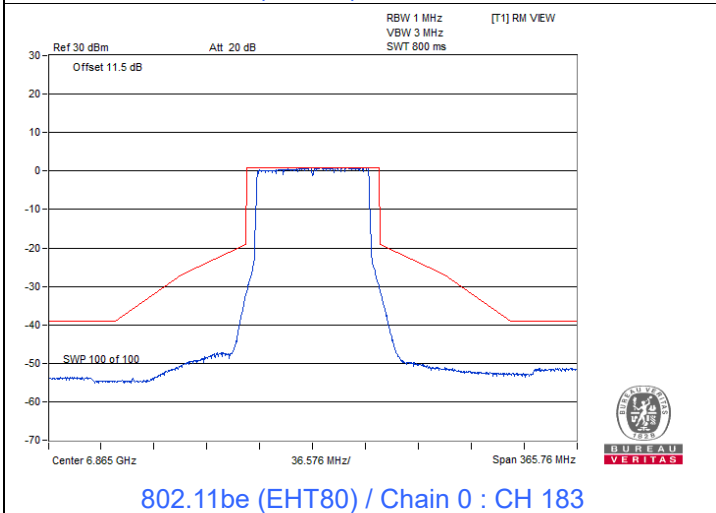
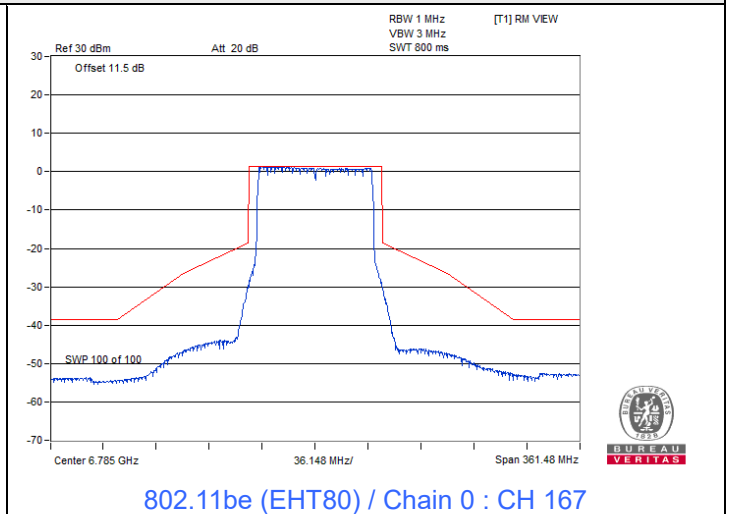
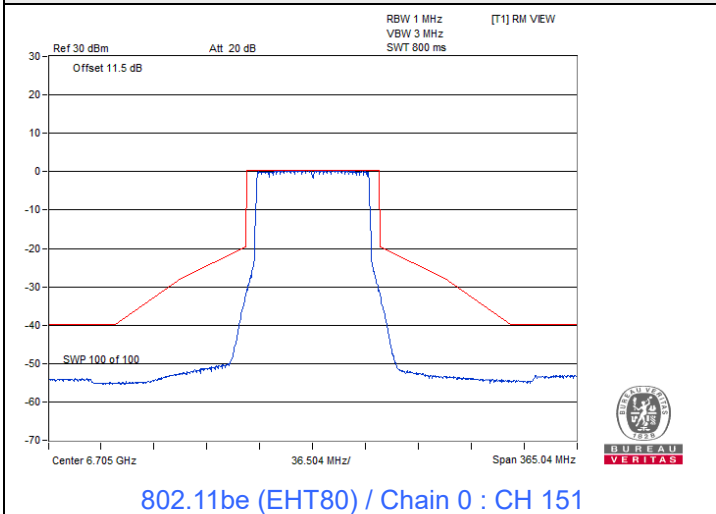

Spectrum Plot

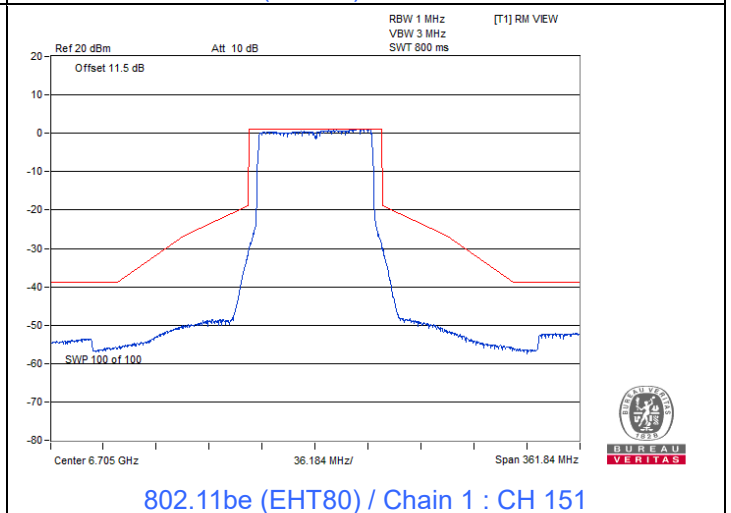
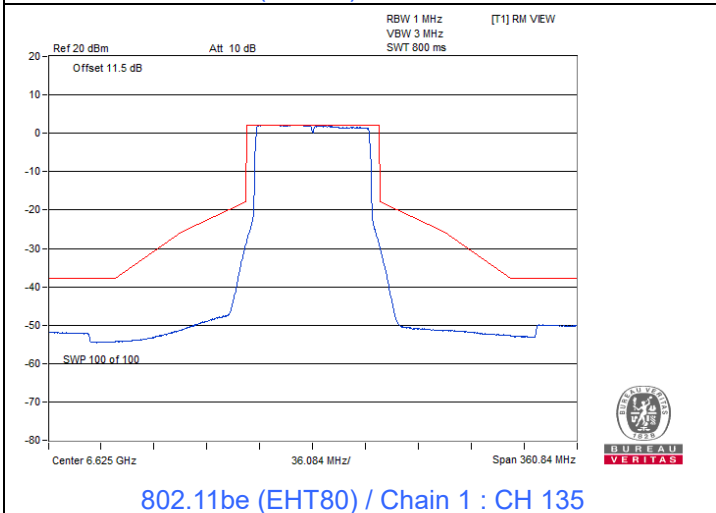
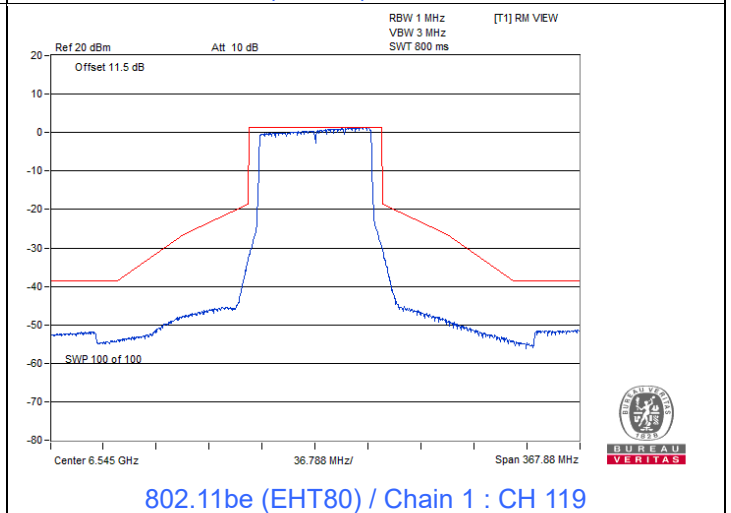
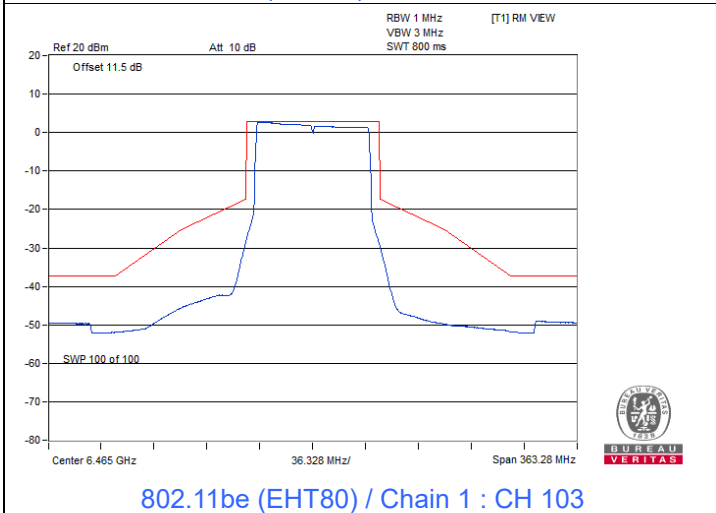
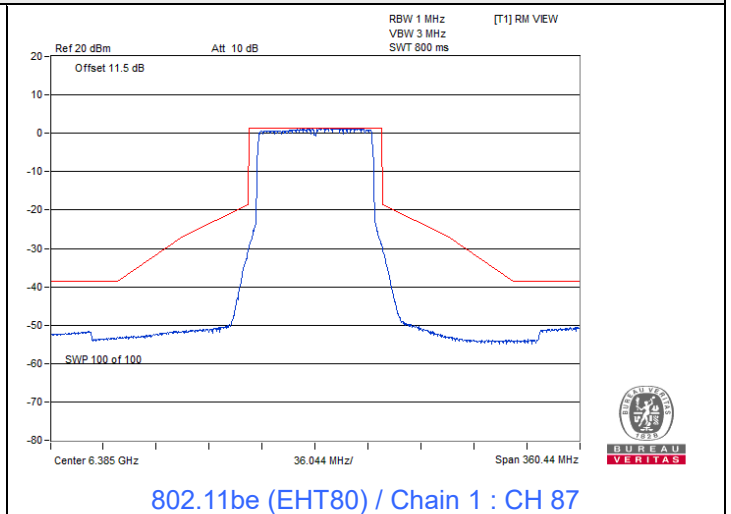
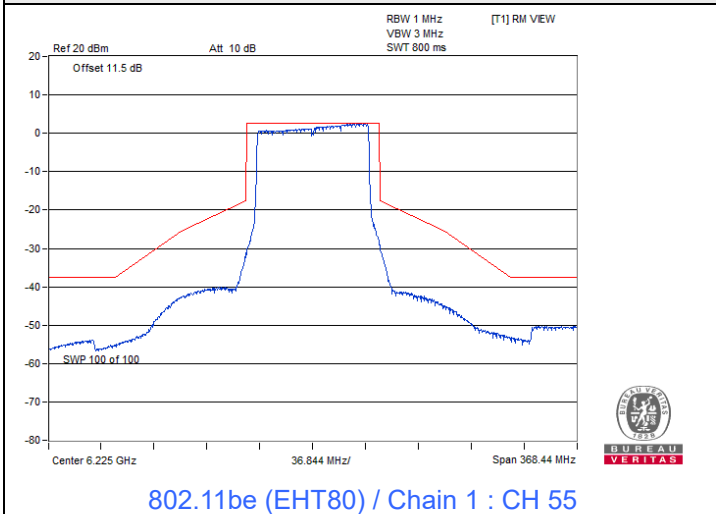

Spectrum Plot

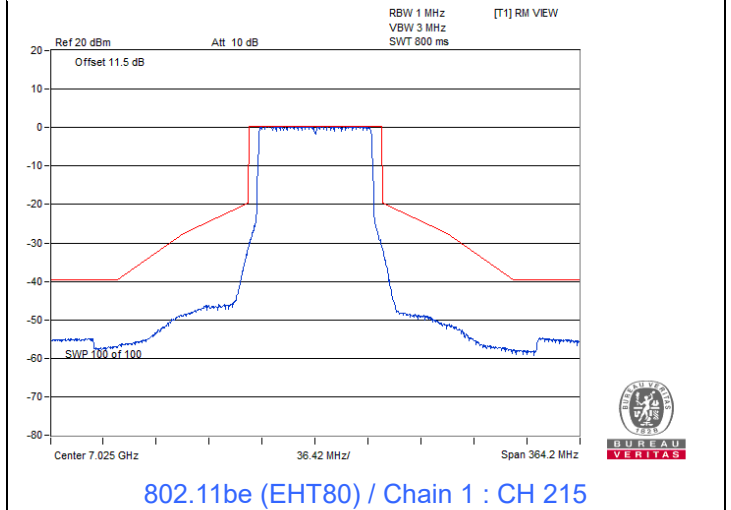
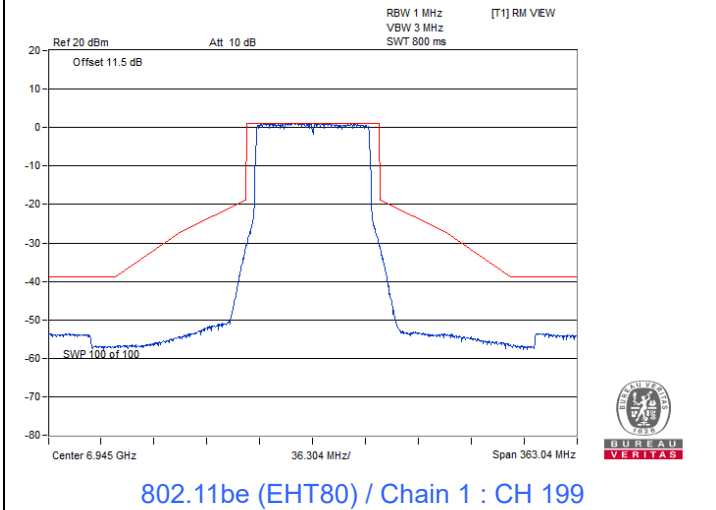
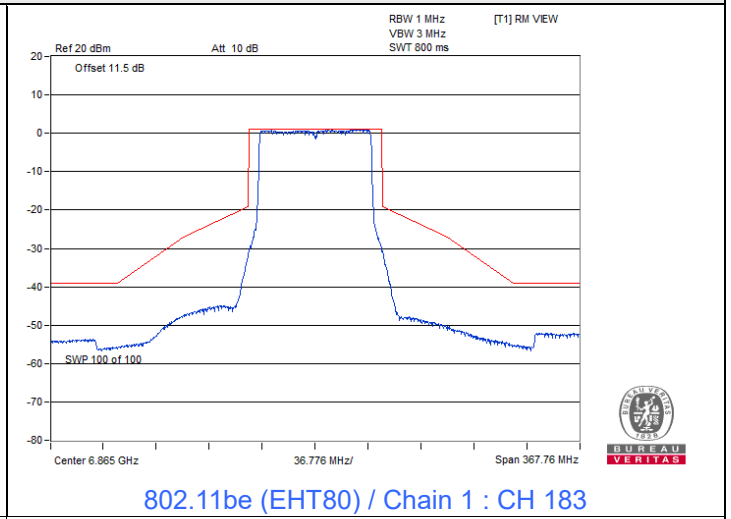
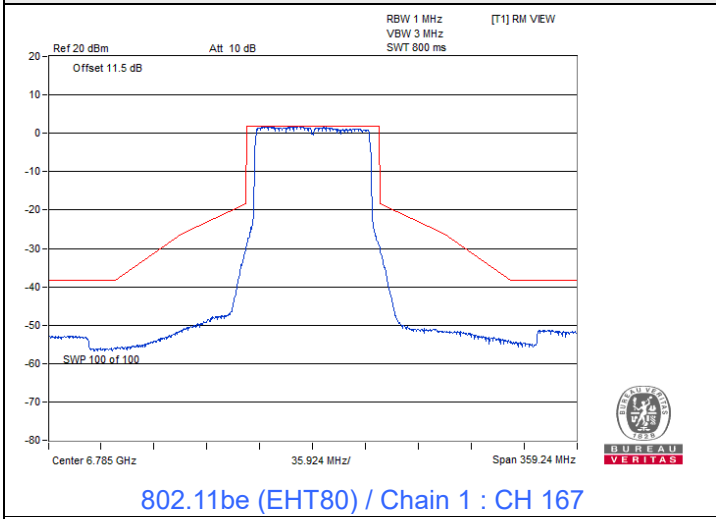



802.11be (EHT160)

Spectrum Plot

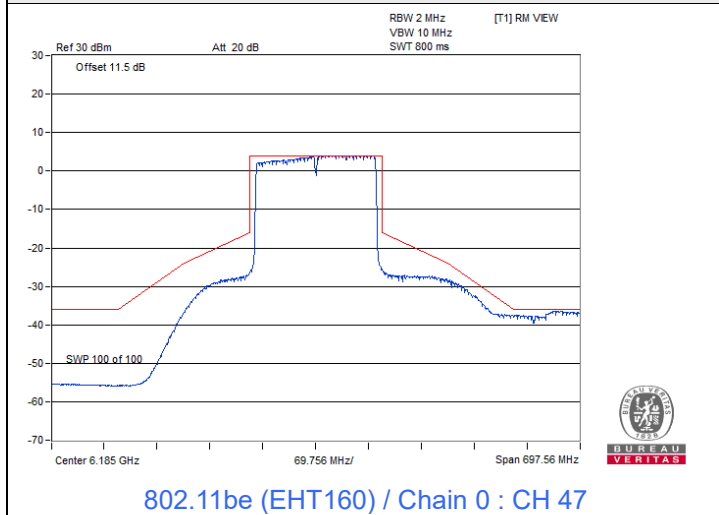

802.11be (EHT160) / Chain 0 : CH 47

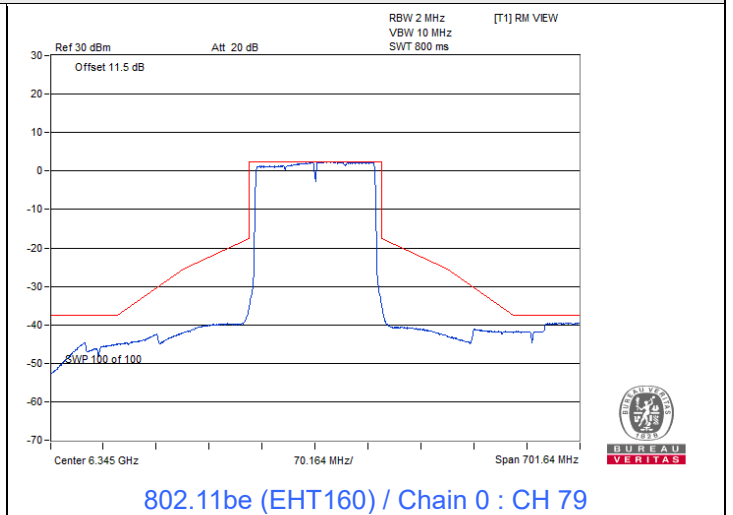

802.11be (EHT160) / Chain 0 : CH 79

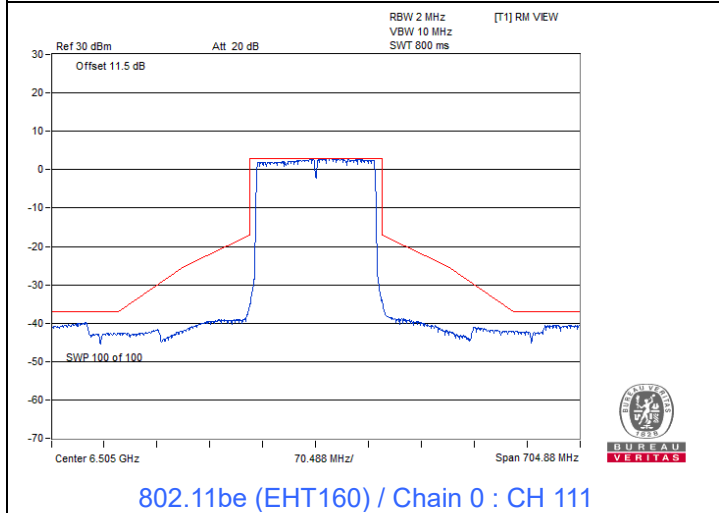

802.11be (EHT160) / Chain 0 : CH 111

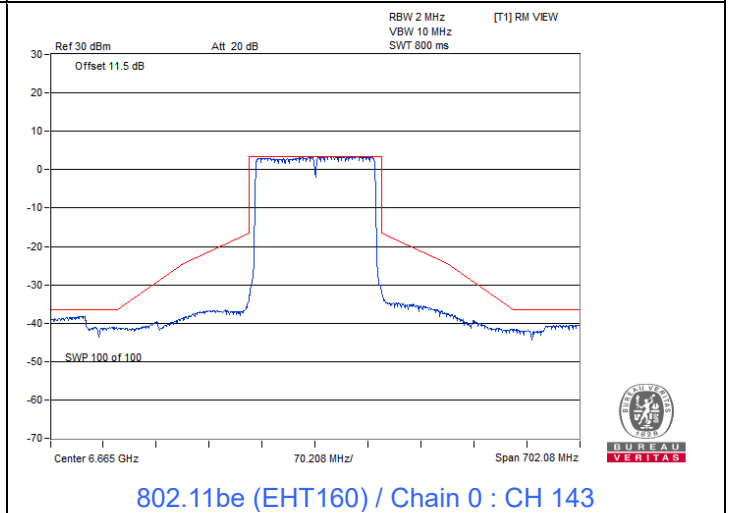

802.11be (EHT160) / Chain 0 : CH 143

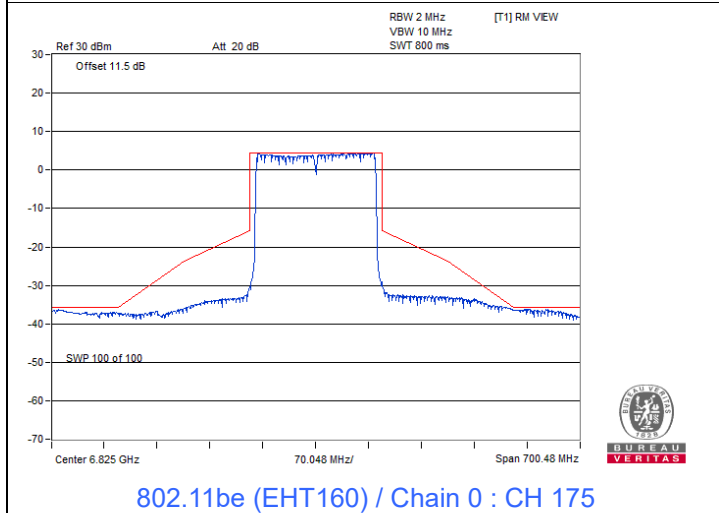

802.11be (EHT160) / Chain 0 : CH 175

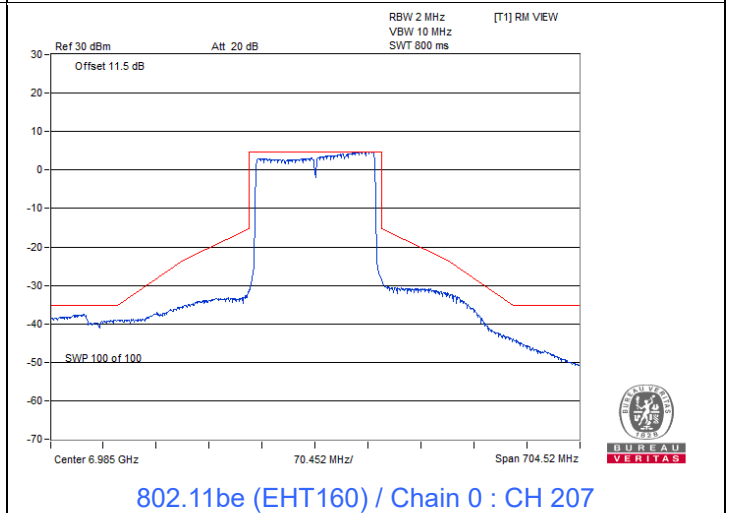

802.11be (EHT160) / Chain 0 : CH 207

Spectrum Plot

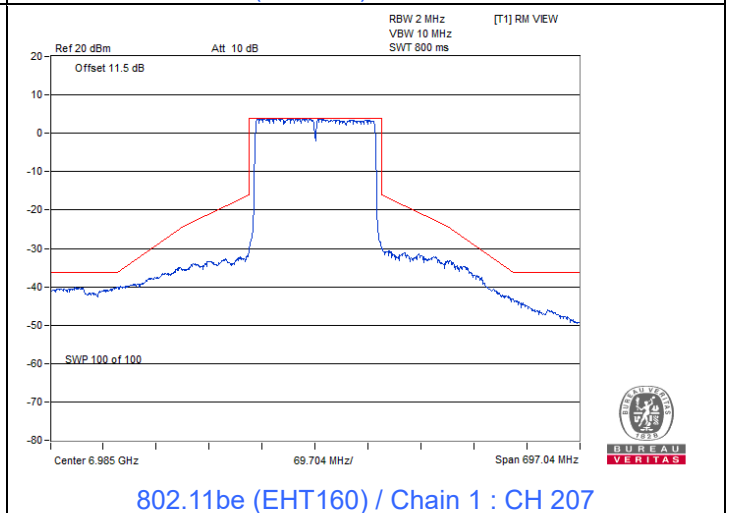
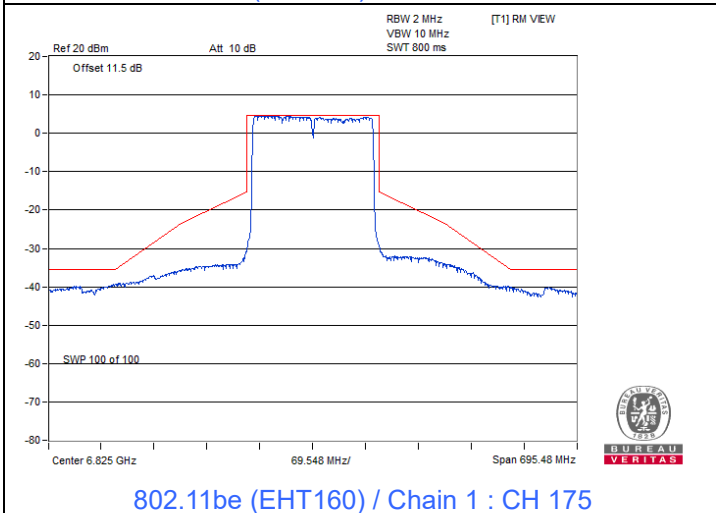
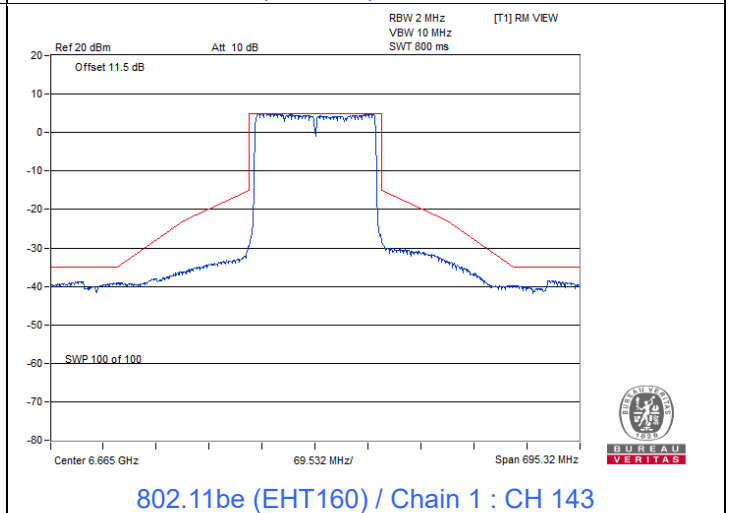
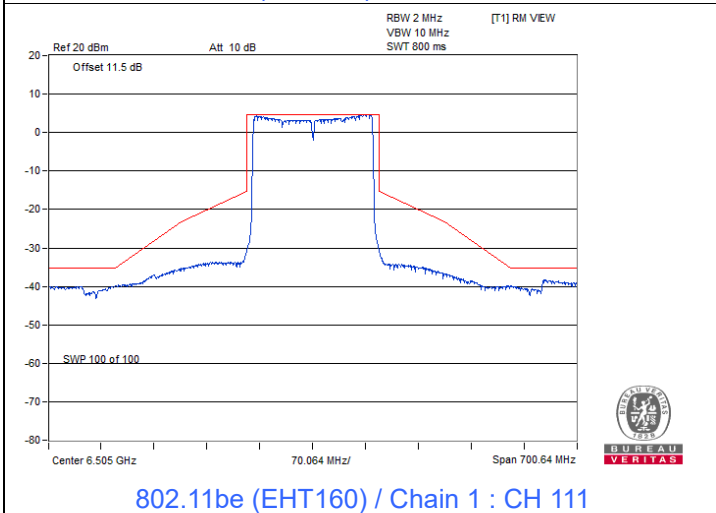
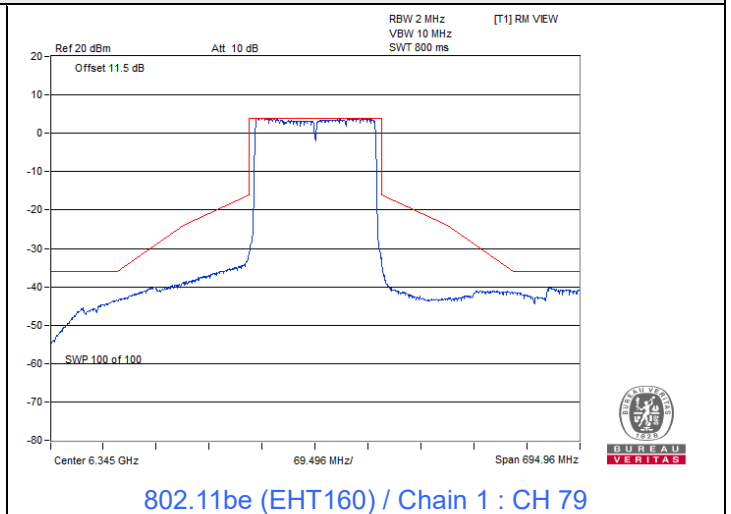
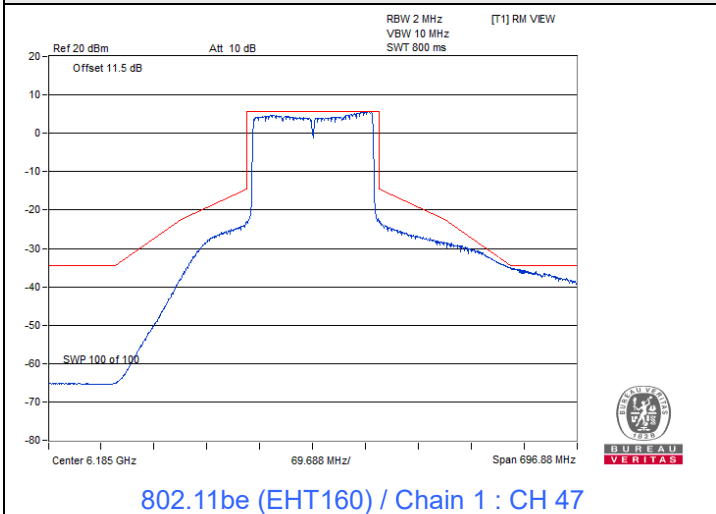



802.11be (EHT320)

Spectrum Plot

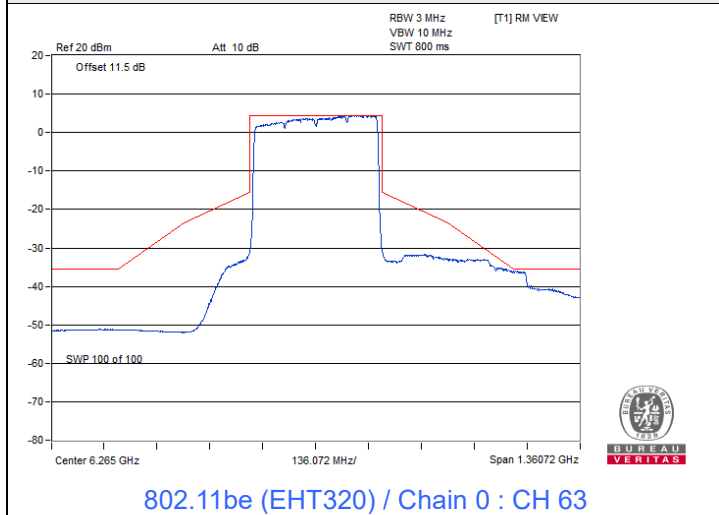

802.11be (EHT320) / Chain 0 : CH 63

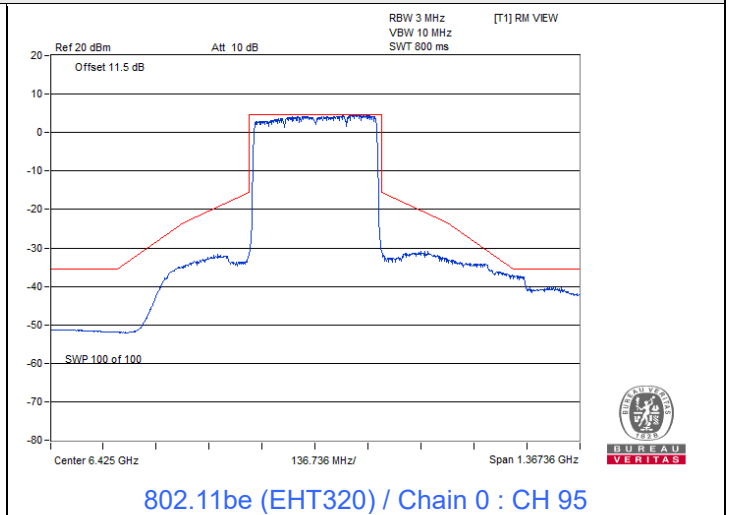

802.11be (EHT320) / Chain 0 : CH 95

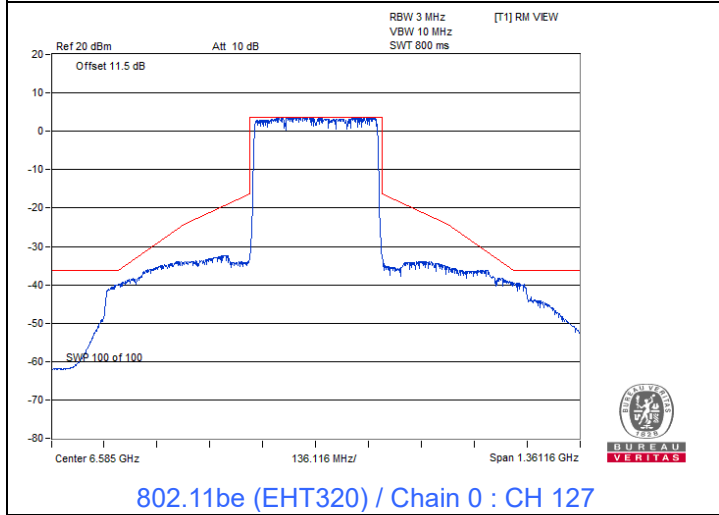

802.11be (EHT320) / Chain 0 : CH 127

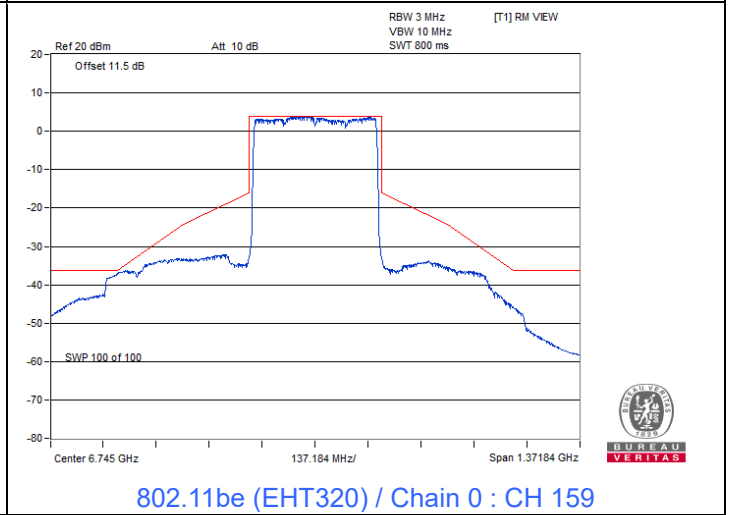

802.11be (EHT320) / Chain 0 : CH 159

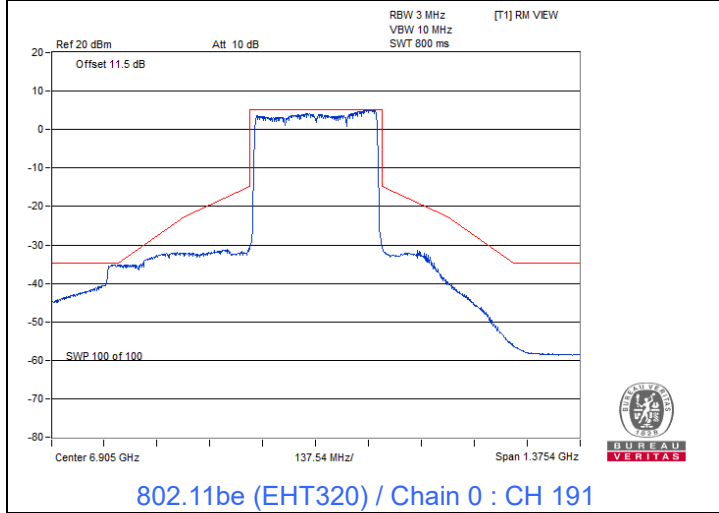

802.11be (EHT320) / Chain 0 : CH 191

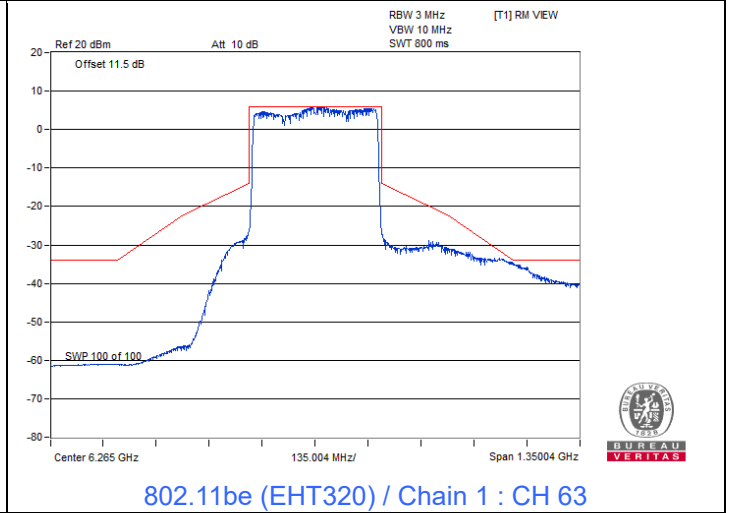

802.11be (EHT320) / Chain 1 : CH 63

Spectrum Plot

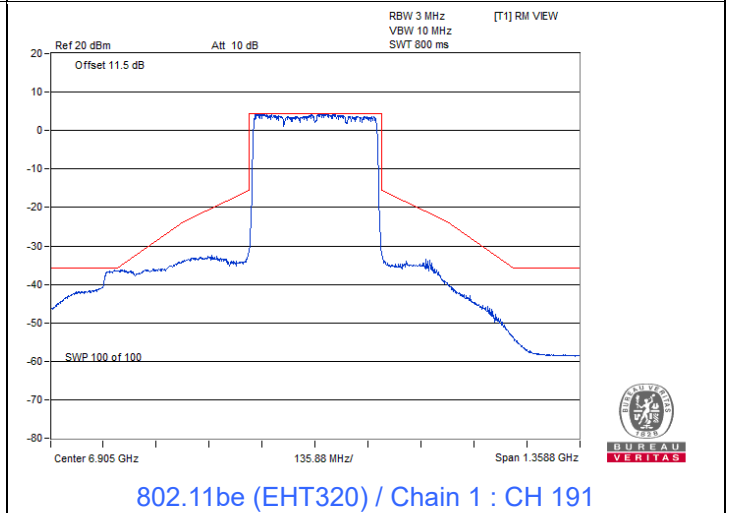
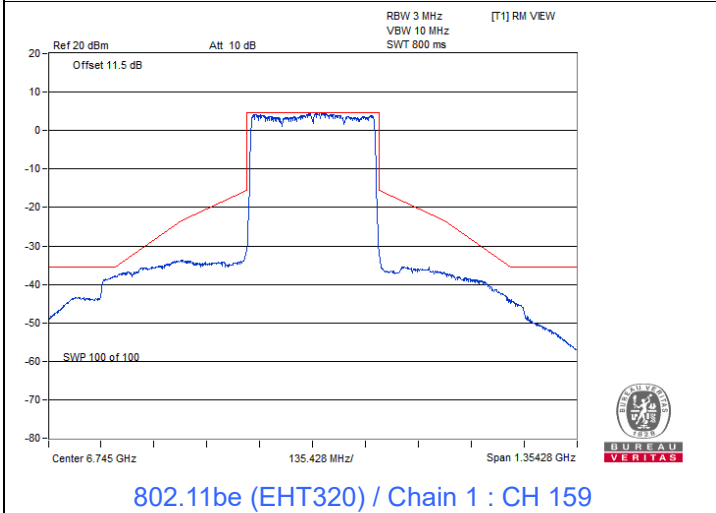
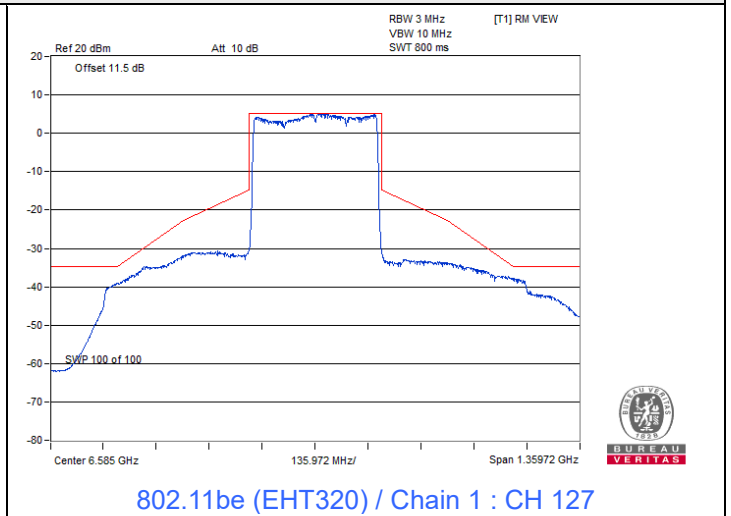
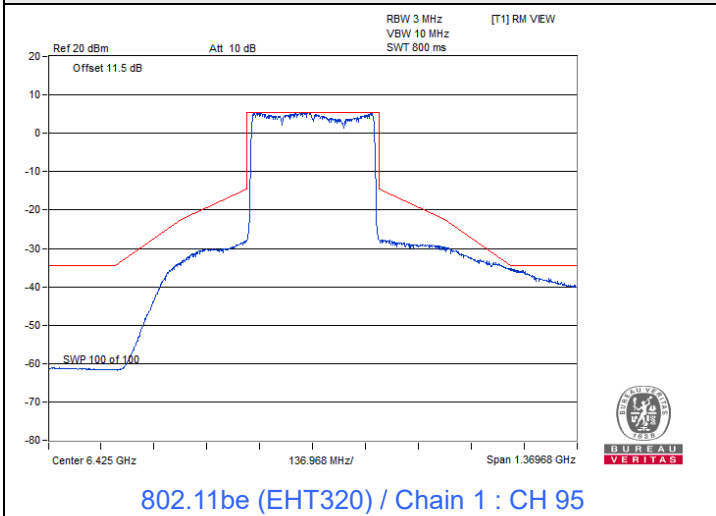

7.5 Occupied Bandwidth

Input Power:	120 Vac, 60 Hz	Environmental Conditions:	25°C, 60% RH	Tested By:	Ivan Tseng, Matthew Yang, Tim Chen, Jisyong Wang
--------------	----------------	---------------------------	--------------	------------	--

802.11a

Channel	Frequency (MHz)	Occupied Bandwidth (MHz)	
		Chain 0	Chain 1
33	6115	16.83	16.92
61	6255	16.92	17.02
93	6415	16.92	17.12
97	6435	16.83	16.92
105	6475	16.93	17.02
113	6515	17.02	17.02
117	6535	17.02	17.02
149	6695	16.92	16.83
181	6855	16.83	16.83
185	6875	16.83	16.93
209	6995	16.93	17.02
229	7095	16.83	16.93
233	7115	16.92	17.02

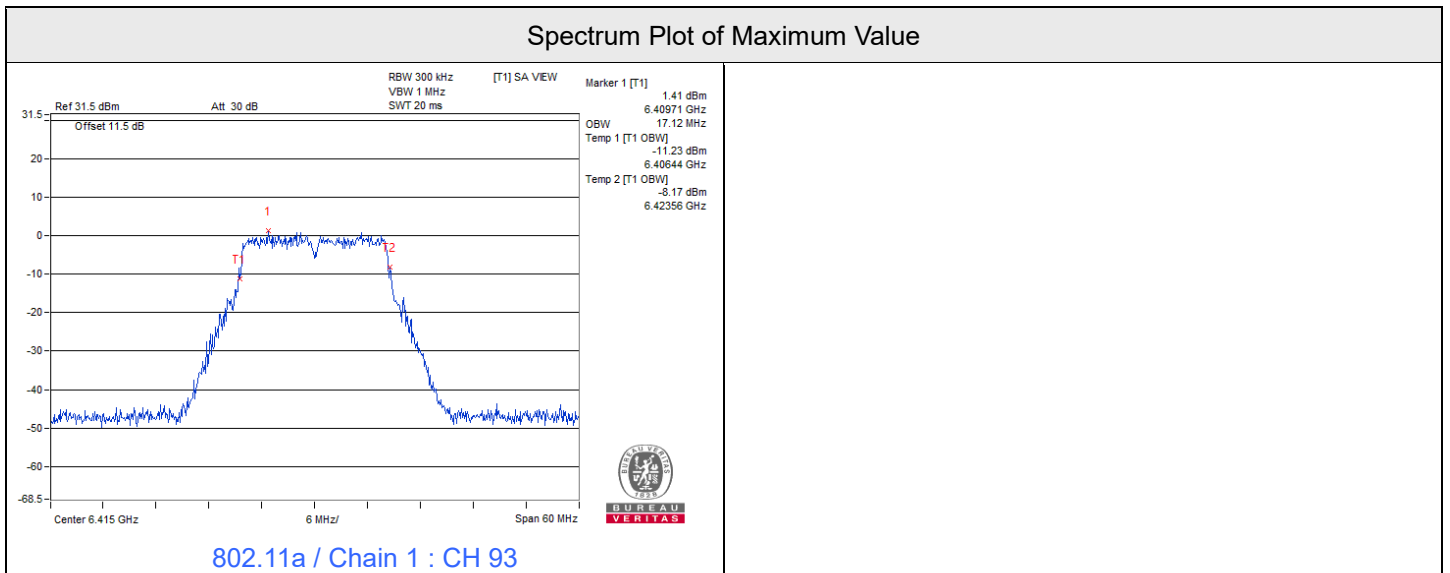

Beamforming (2T1S)

802.11be (EHT20)

Channel	Frequency (MHz)	Occupied Bandwidth (MHz)	
		Chain 0	Chain 1
33	6115	19.14	19.14
61	6255	19.14	19.04
93	6415	19.14	19.04
97	6435	19.14	19.04
105	6475	19.14	19.14
113	6515	19.14	19.14
117	6535	19.14	19.14
149	6695	19.04	19.04
181	6855	19.14	19.14
185	6875	19.14	19.14
209	6995	19.14	19.14
229	7095	19.14	19.14
233	7115	19.14	19.04

802.11be (EHT40)

Channel	Frequency (MHz)	Occupied Bandwidth (MHz)	
		Chain 0	Chain 1
35	6125	38.46	38.40
59	6245	38.46	38.16
91	6405	38.27	38.64
99	6445	38.27	38.16
107	6485	38.27	38.40
115	6525	38.46	38.16
123	6565	38.27	38.16
155	6725	38.46	38.46
179	6845	38.46	38.40
187	6885	38.27	38.40
211	7005	38.08	38.40
227	7085	38.27	38.40

802.11be (EHT80)

Channel	Frequency (MHz)	Occupied Bandwidth (MHz)	
		Chain 0	Chain 1
39	6145	77.70	77.76
55	6225	77.70	78.24
87	6385	78.08	77.76
103	6465	77.31	77.76
119	6545	78.08	77.76
135	6625	78.08	77.76
151	6705	77.31	78.24
167	6785	78.08	77.28
183	6865	77.70	77.28
199	6945	77.69	77.76
215	7025	78.08	77.76

802.11be (EHT160)

Channel	Frequency (MHz)	Occupied Bandwidth (MHz)	
		Chain 0	Chain 1
47	6185	157.69	157.44
79	6345	157.69	157.44
111	6505	157.69	157.44
143	6665	157.69	157.44
175	6825	157.69	158.40
207	6985	157.69	157.44

802.11be (EHT320)

Channel	Frequency (MHz)	Occupied Bandwidth (MHz)		Maximum Limit (MHz)	Test Result
		Chain 0	Chain 1		
63	6265	316.92	316.92	320	Pass
95	6425	316.80	316.80	320	Pass
127	6585	316.80	316.80	320	Pass
159	6745	316.80	316.80	320	Pass
191	6905	316.80	316.80	320	Pass



Spectrum Plot of Maximum Value

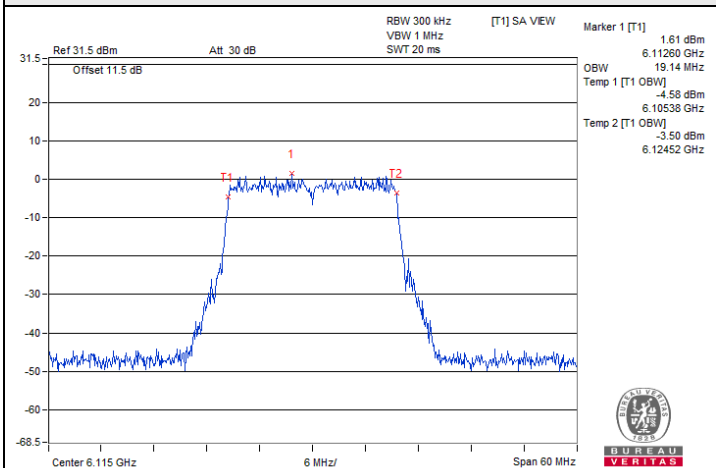

802.11be (EHT20) / Chain 0 : CH 33

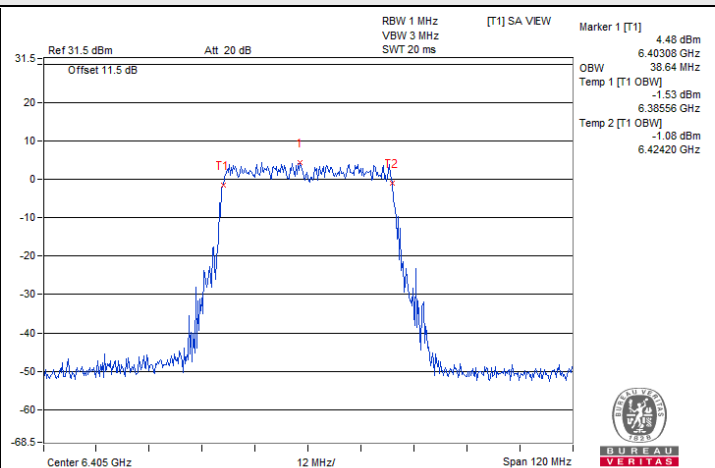

802.11be (EHT40) / Chain 1 : CH 91

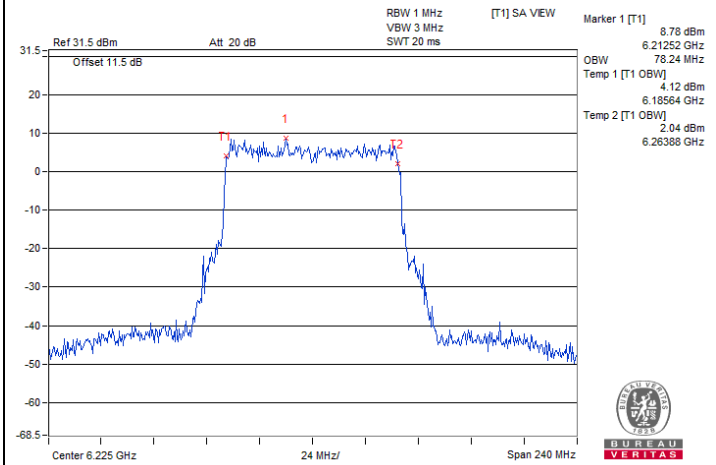

802.11be (EHT80) / Chain 1 : CH 55

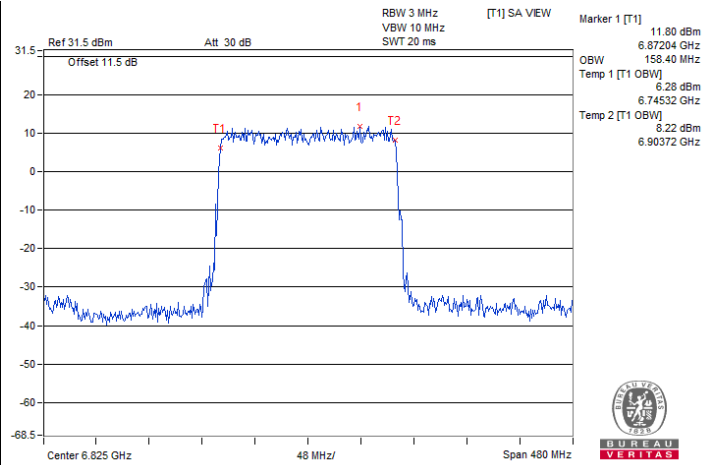

802.11be (EHT160) / Chain 1 : CH 175

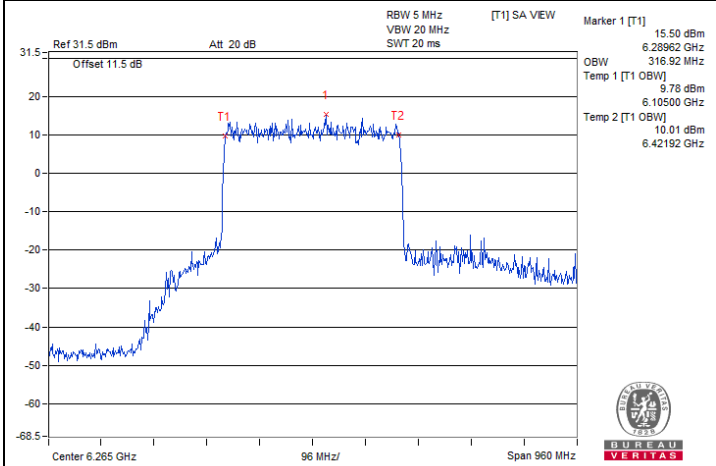

802.11be (EHT320) / Chain 0 : CH 63

Beamforming (2T2S)

802.11be (EHT20)

Channel	Frequency (MHz)	Occupied Bandwidth (MHz)	
		Chain 0	Chain 1
33	6115	19.08	19.08
61	6255	19.08	19.08
93	6415	19.08	19.20
97	6435	19.08	19.08
105	6475	19.08	19.32
113	6515	19.08	19.08
117	6535	19.08	19.20
149	6695	19.08	19.08
181	6855	19.08	19.20
185	6875	19.08	19.20
209	6995	19.20	19.20
229	7095	19.08	19.20
233	7115	19.20	19.32

802.11be (EHT40)

Channel	Frequency (MHz)	Occupied Bandwidth (MHz)	
		Chain 0	Chain 1
35	6125	38.64	38.40
59	6245	38.64	38.40
91	6405	38.64	38.64
99	6445	38.64	38.64
107	6485	38.64	38.64
115	6525	38.64	38.64
123	6565	38.40	38.88
155	6725	38.64	38.64
179	6845	38.88	38.64
187	6885	38.64	38.40
211	7005	38.40	38.64
227	7085	38.64	38.64

802.11be (EHT80)

Channel	Frequency (MHz)	Occupied Bandwidth (MHz)	
		Chain 0	Chain 1
39	6145	77.76	78.24
55	6225	78.24	77.76
87	6385	78.24	77.76
103	6465	77.76	78.24
119	6545	78.24	77.76
135	6625	78.24	78.24
151	6705	78.24	77.76
167	6785	78.24	78.24
183	6865	77.76	78.24
199	6945	78.24	78.24
215	7025	77.76	78.24

802.11be (EHT160)

Channel	Frequency (MHz)	Occupied Bandwidth (MHz)	
		Chain 0	Chain 1
47	6185	158.40	158.40
79	6345	157.44	158.40
111	6505	157.44	158.40
143	6665	158.40	158.40
175	6825	158.40	158.40
207	6985	157.44	158.40

802.11be (EHT320)

Channel	Frequency (MHz)	Occupied Bandwidth (MHz)		Maximum Limit (MHz)	Test Result
		Chain 0	Chain 1		
63	6265	318.72	318.72	320	Pass
95	6425	316.80	318.72	320	Pass
127	6585	316.80	318.72	320	Pass
159	6745	316.80	316.80	320	Pass
191	6905	318.72	316.80	320	Pass



Spectrum Plot of Maximum Value

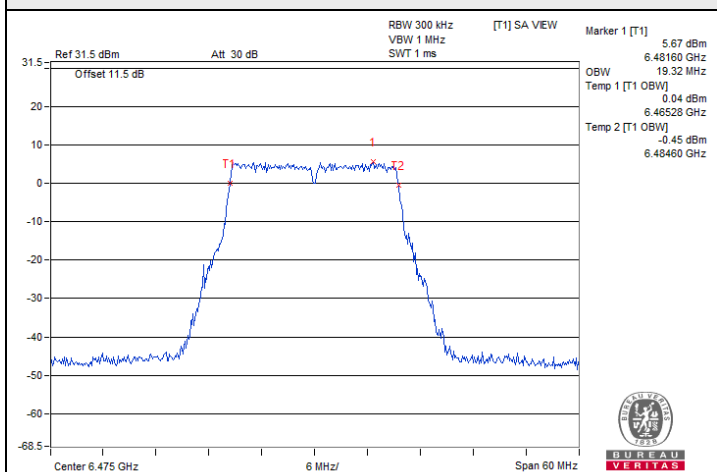

802.11be (EHT20) / Chain 1 : CH 105

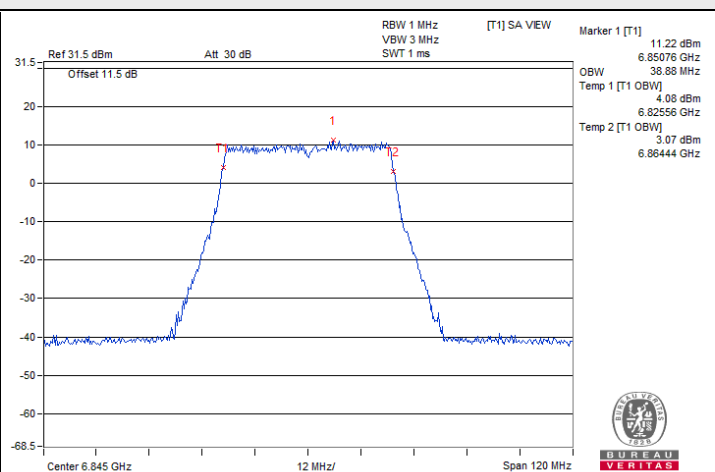

802.11be (EHT40) / Chain 0 : CH 179

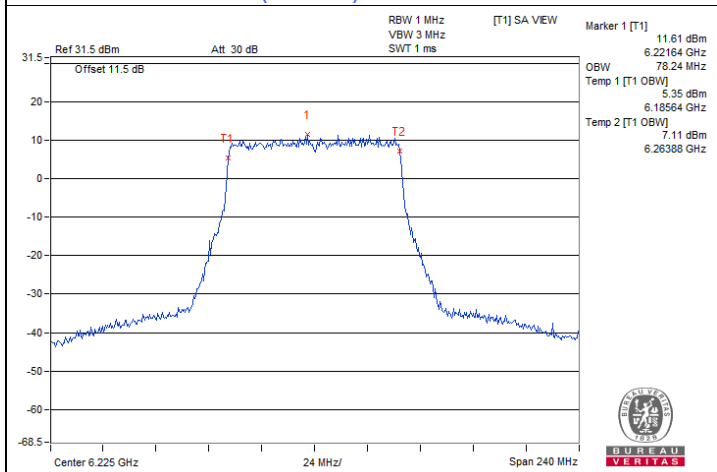

802.11be (EHT80) / Chain 0 : CH 55

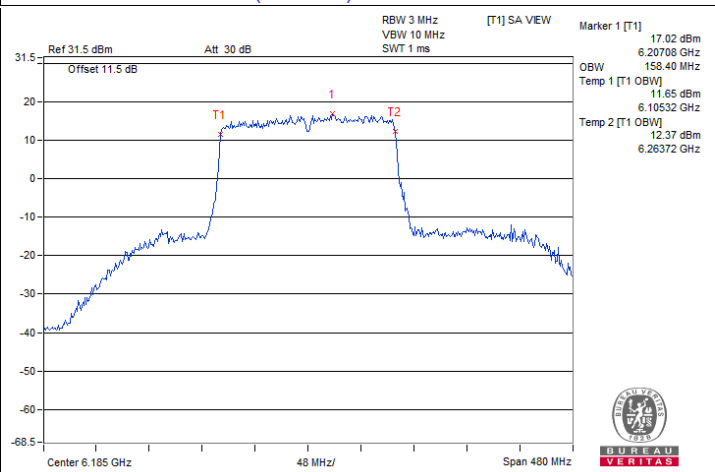

802.11be (EHT160) / Chain 0 : CH 47

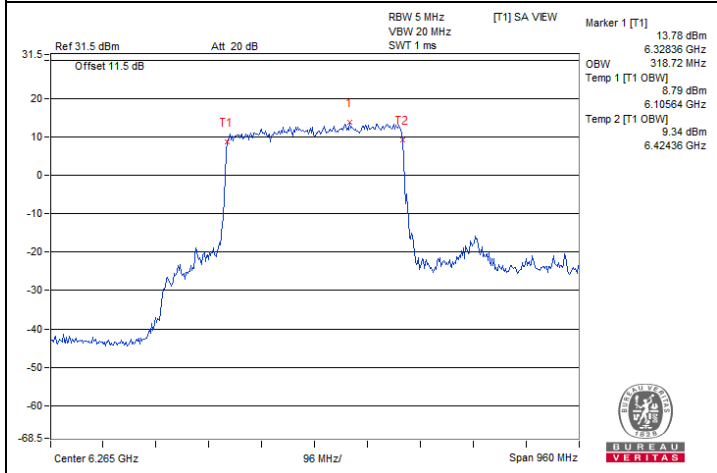

802.11be (EHT320) / Chain 0 : CH 63

7.6 Frequency Stability

Input Power:	120 Vac, 60 Hz	Environmental Conditions:	25°C, 60% RH	Tested By:	Ivan Tseng, Matthew Yang, Tim Chen, Jisyong Wang
--------------	----------------	---------------------------	--------------	------------	--

802.11a

Frequency Stability Versus Temperature									
Operating Frequency: 6115 MHz									
Temp. (°C)	Power Supply (Vac)	0 Minute		2 Minutes		5 Minutes		10 Minutes	
		Measured Frequency (MHz)	Test Result	Measured Frequency (MHz)	Test Result	Measured Frequency (MHz)	Test Result	Measured Frequency (MHz)	Test Result
35	120	6114.9766	Pass	6114.9814	Pass	6114.9777	Pass	6114.9766	Pass
30	120	6115.0217	Pass	6115.0229	Pass	6115.0209	Pass	6115.0209	Pass
20	120	6115.0167	Pass	6115.0137	Pass	6115.0164	Pass	6115.0178	Pass
10	120	6115.03	Pass	6115.0321	Pass	6115.0304	Pass	6115.0309	Pass
0	120	6114.9827	Pass	6114.9885	Pass	6114.9878	Pass	6114.9838	Pass

Frequency Stability Versus Voltage									
Operating Frequency: 6115 MHz									
Temp. (°C)	Power Supply (Vac)	0 Minute		2 Minutes		5 Minutes		10 Minutes	
		Measured Frequency (MHz)	Test Result	Measured Frequency (MHz)	Test Result	Measured Frequency (MHz)	Test Result	Measured Frequency (MHz)	Test Result
20	138	6115.0091	Pass	6115.0056	Pass	6115.0085	Pass	6115.0092	Pass
	120	6115.0167	Pass	6115.0137	Pass	6115.0164	Pass	6115.0178	Pass
	102	6115.0191	Pass	6115.0194	Pass	6115.0151	Pass	6115.0176	Pass

7.7 Contention-based Protocol

Environmental Conditions:	25°C, 60% RH	Tested By:	Stan Shih
---------------------------	--------------	------------	-----------

Mode A

Companion Device Information			
Product	Brand	Model No.	Software/Firmware Version
Router	Netgear	RS700	V1.0.7.77_23.11.14-CBP-ucode 1824-1790

Note: The EUT device modulation technique OFDMA does not support partial RUs (resource units) and channel puncturing/bandwidth reduction mechanisms.



Contention Based Protocol Measurement														
Operation Mode	Channel Bandwidth (MHz)	Channel Number	Channel Freq. (MHz)	Injected Signal (AWGN)		Antenna Gain (dBi)	Path Loss (dB) (Note 3)	Adjusted Power (dBm)	Detection Limit	EUT TX Status				
				Freq. (MHz)	Power (dBm)									
802.11be	20	65	6275	6275	-70	2.58	0	-72.58	-62	OFF				
					-73	2.58	0	-75.58	-62	Minimal				
					-79.42	2.58	0	-82	-62	ON				
	320	63	6265	6110	-66	2.58	0	-68.58	-62	OFF				
					-69	2.58	0	-71.58	-62	Minimal				
					-79.42	2.58	0	-82	-62	ON				
	6265	63	6265	6265	-66	2.58	0	-68.58	-62	OFF				
					-71	2.58	0	-73.58	-62	Minimal				
					-79.42	2.58	0	-82	-62	ON				
					6420	63	6265	6420	-73	2.58	0	-75.58	-62	OFF
									-75	2.58	0	-77.58	-62	Minimal
									-79.42	2.58	0	-82	-62	ON

Notes:

1. After investigation (consider antenna gain and path loss) , the one representative port (Chain 0) was measured and presented in the report.
2. Adjusted Power (dBm) = Injected Signal (AWGN) Power (dBm) - Antenna Gain (dBi) + Path Loss (dB)
3. Antenna gain values include all the applicable path losses.

Contention Based Protocol Detection Probability															
Operation Mode	Channel Bandwidth (MHz)	AWGN Signal Freq. (MHz)	#01	#02	#03	#04	#05	#06	#07	#08	#09	#10	Detection Probability	Detection Limit	Test Result
802.11be	20	6275	v	v	v	v	v	v	v	v	v	v	100%	90%	Pass
	320	6110	v	v	v	v	v	v	v	v	v	v	100%	90%	Pass
		6265	v	v	v	v	v	v	v	v	v	v	100%	90%	Pass
		6420	v	v	v	v	v	v	v	v	v	v	100%	90%	Pass

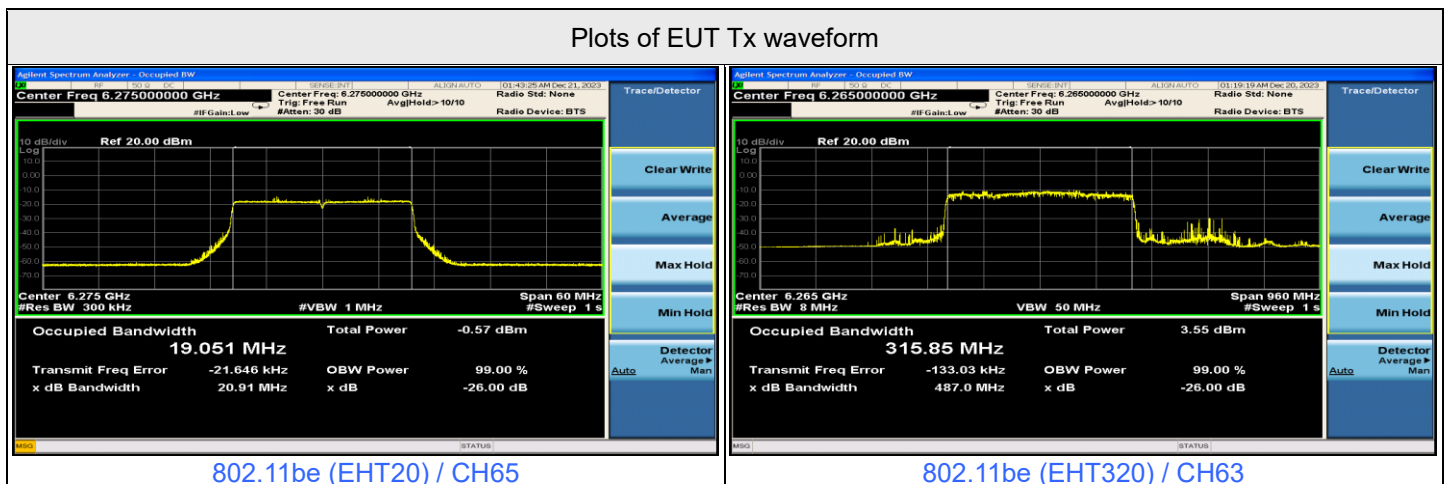

Plots of Injected signal (AWGN) level

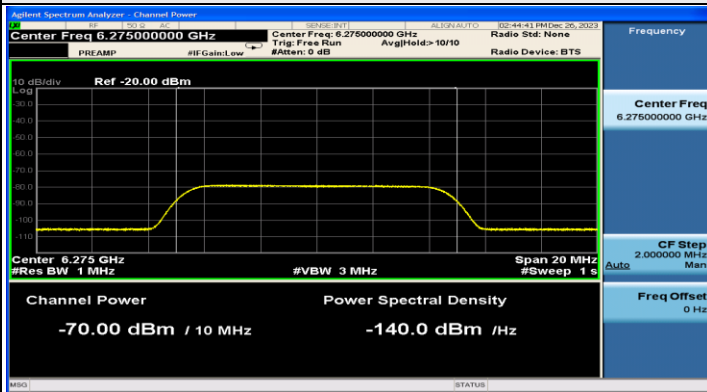

802.11be (EHT20) / CH65

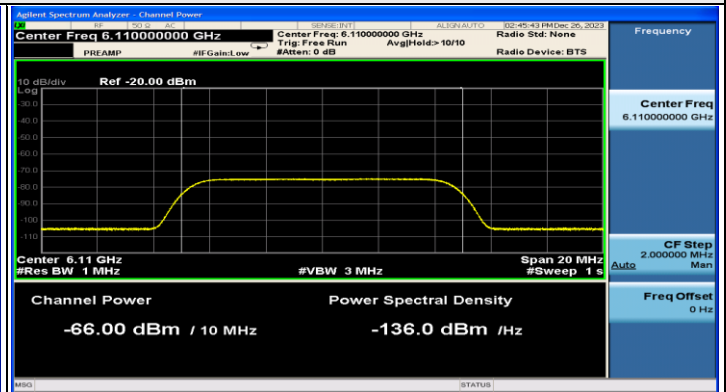

802.11be (EHT320) / CH63(Low Edge)

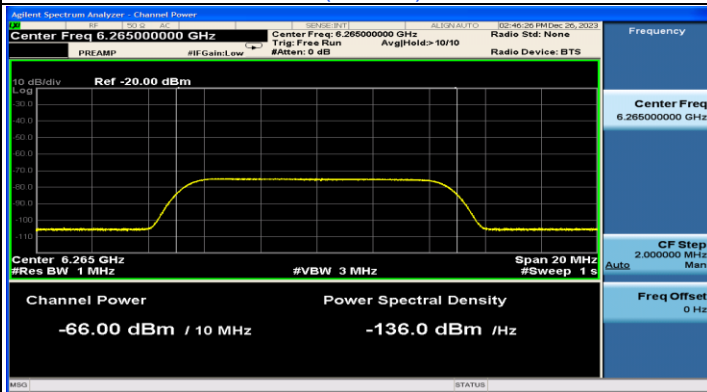

802.11be (EHT320) / CH63(Middle)

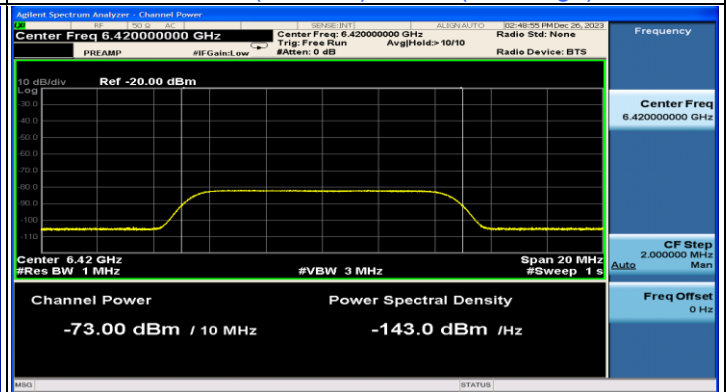

802.11be (EHT320) / CH63(High Edge)

Plots of EUT ceased transmission in the time domain

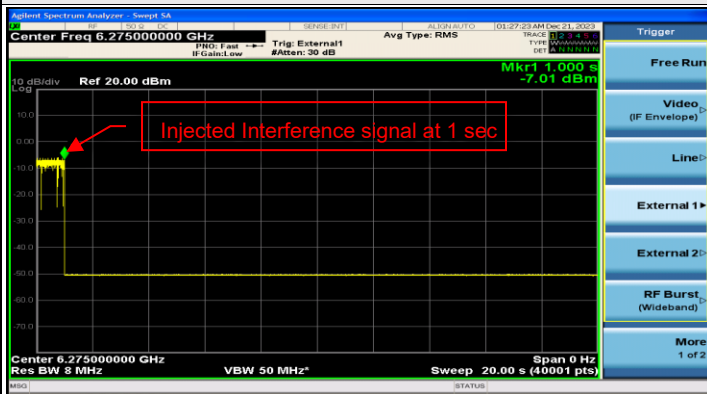

802.11be (EHT20) / CH65

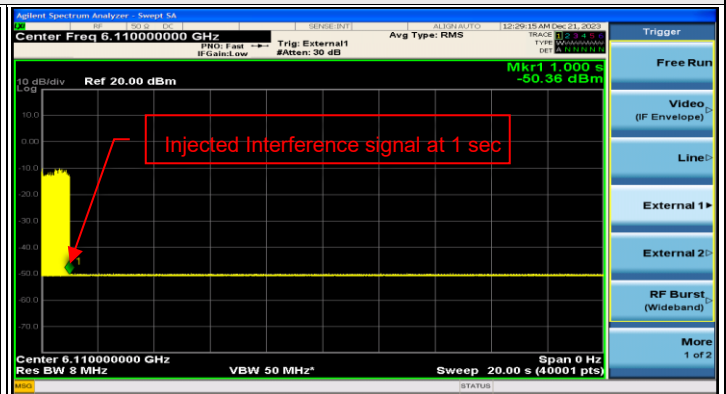

802.11be (EHT320) / CH63 (Low Edge)

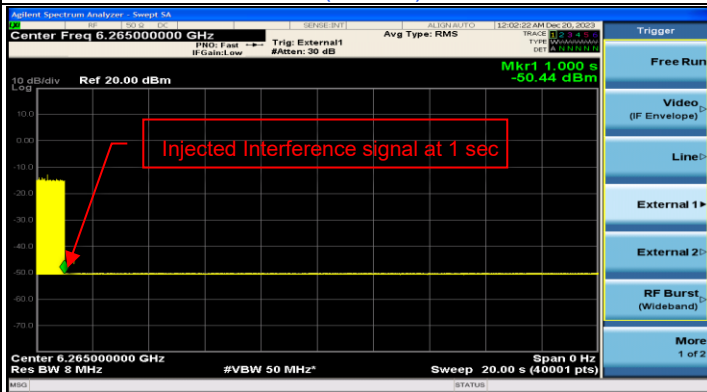

802.11be (EHT320) / CH63(Middle)

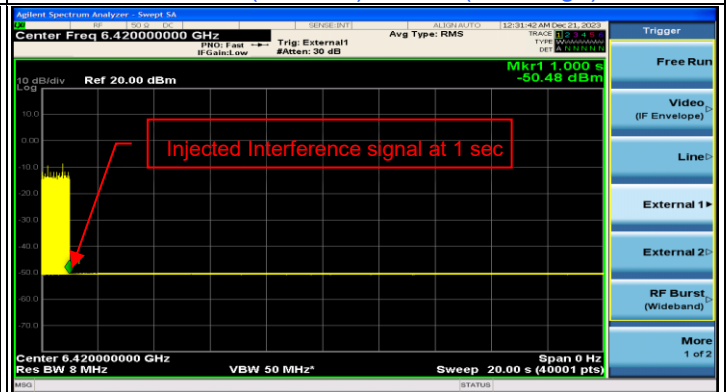

802.11be (EHT320) / CH63(High Edge)



For U-NII-6

Contention Based Protocol Measurement										
Operation Mode	Channel Bandwidth (MHz)	Channel Number	Channel Freq. (MHz)	Injected Signal (AWGN)		Antenna Gain (dBi)	Path Loss (dB) (Note 3)	Adjusted Power (dBm)	Detection Limit	EUT TX Status
				Freq. (MHz)	Power (dBm)					
802.11be	20	101	6455	6455	-70	2.58	0	-72.58	-62	OFF
					-74	2.58	0	-76.58	-62	Minimal
					-79.42	2.58	0	-82	-62	ON
	320	95	6425	6270	-73	2.58	0	-75.58	-62	OFF
					-77	2.58	0	-79.58	-62	Minimal
					-79.42	2.58	0	-82	-62	ON
		6425	-66	2.58	0	-68.58	-62	OFF		
			-72	2.58	0	-74.58	-62	Minimal		
			-79.42	2.58	0	-82	-62	ON		
			6580	-68	2.58	0	-70.58	-62	OFF	
				-71	2.58	0	-73.58	-62	Minimal	
				-79.42	2.58	0	-82	-62	ON	

Notes:

1. After investigation (consider antenna gain and path loss) , the one representative port (Chain 0) was measured and presented in the report.
2. Adjusted Power (dBm) = Injected Signal (AWGN) Power (dBm) - Antenna Gain (dBi) + Path Loss (dB)
3. Antenna gain values include all the applicable path losses.

Contention Based Protocol Detection Probability															
Operation Mode	Channel Bandwidth (MHz)	AWGN Signal Freq. (MHz)	#01	#02	#03	#04	#05	#06	#07	#08	#09	#10	Detection Probability	Detection Limit	Test Result
			802.11be	20	6455	v	v	v	v	v	v	v			
802.11be	320	6270	v	v	v	v	v	v	v	v	v	v	100%	90%	Pass
		6425	v	v	v	v	v	v	v	v	v	v	100%	90%	Pass
		6580	v	v	v	v	v	v	v	v	v	v	v	100%	90%

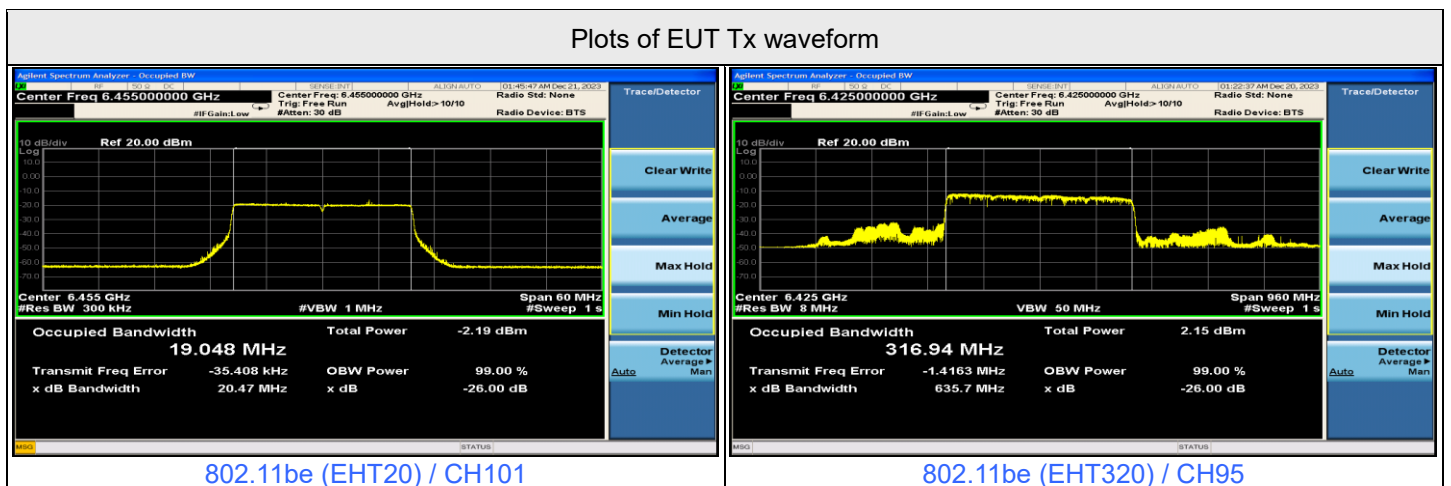

Plots of Injected signal (AWGN) level

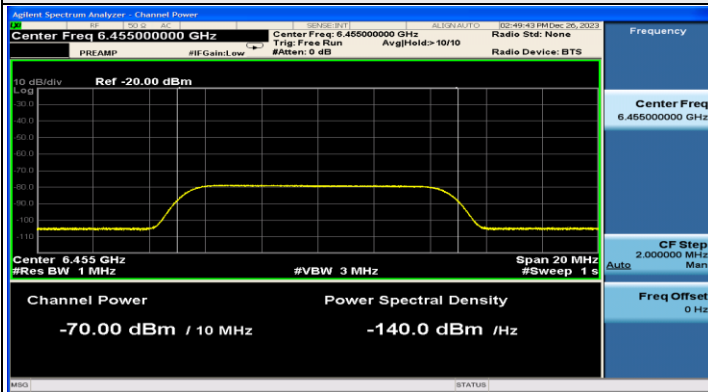

802.11be (EHT20) / CH101

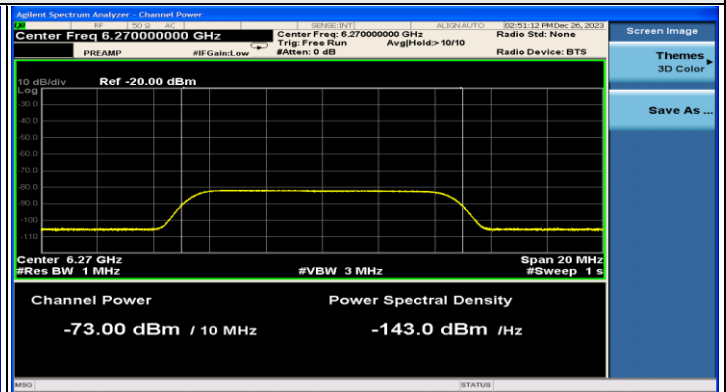

802.11be (EHT320) / CH95(Low Edge)

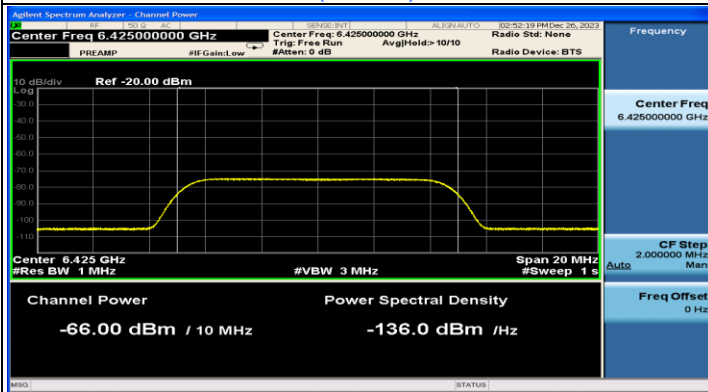

802.11be (EHT320) / CH95(Middle)

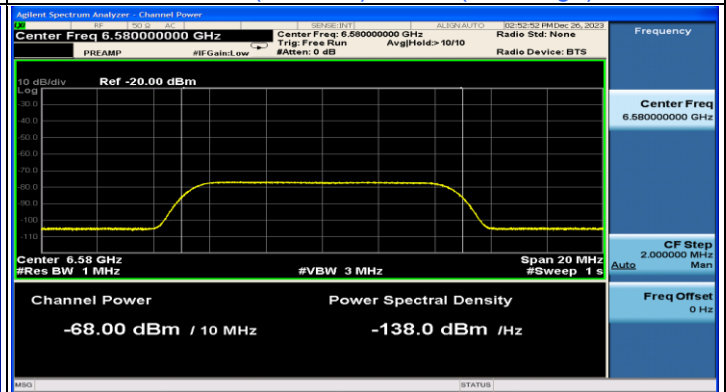

802.11be (EHT320) / CH95(High Edge)

Plots of EUT ceased transmission in the time domain



802.11be (EHT20) / CH101

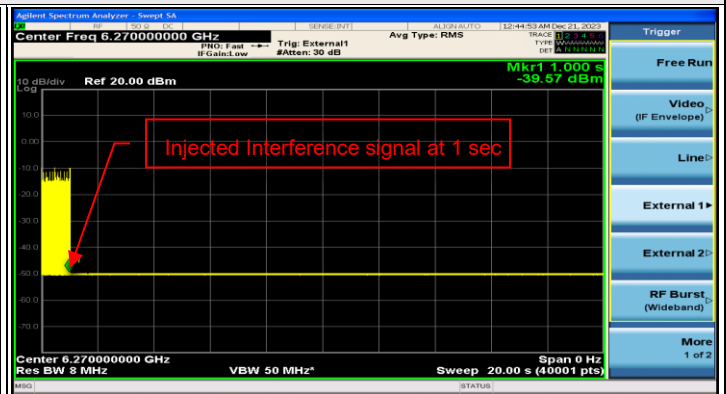

802.11be (EHT320) / CH95(Low Edge)

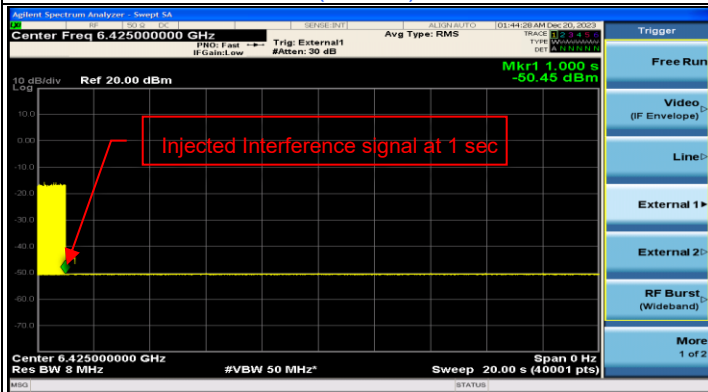

802.11be (EHT320) / CH95(Middle)

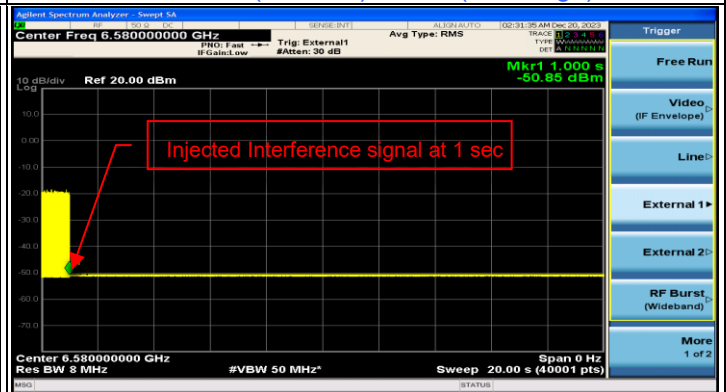

802.11be (EHT320) / CH95(High Edge)