



權億科技股份有限公司  
Master Wave Technology Co., Ltd.

## 承認書

## APPROVAL SHEET

Customers: NETGEAR Inc.

Customer Model No.:

Master Wave Model No. 907X00747X35

Product Description: 2+5G銅管天線

Issue Date: 2022/01/21

REV.: 01

客戶承認用印		權億承認用印	
			
核准 Approve	主管 Chief	承辦 Responsible	
Hero	Matt	Grace	

### MASTER WAVE TECHNOLOGY CO., LTD.

權億科技股份有限公司

Address: No. 19, Hezun N. Rd., Zhongli Dist., Taoyuan City 320, Taiwan (R.O.C.)

Tel: +886-3-4529998 Fax: +886-3-4522866

### Shengyih Electronic Plastic Co. Ltd (Shou Zhou)

聲億電子塑膠有限公司(蘇州廠)

Address: No.95 Wusong south Rd of Luzhi Town Wu zhong Area Suzhou City, China

Tel : +86-512-65046030 Fax : +86-512-65046033

### Shengyih Electronic Co. Ltd (Dongguan)

聲億電子有限公司(東莞廠)

Address: Mu-Lun Administration Area, Changping Town, Dongguan City, Guangdong Province, China

Tel : +86-769-83914045 Fax : +86-769-83914046



## Table of Contents

### Item

---

#### 1. Antenna Specifications

-Drawing

---

#### 2. Test Report

-Electrical test  
-Antenna Efficiency  
-Pattern test

---

#### 3. Material Certifications

-Connector  
-Cable

---

#### 4. Packing

-PE Bag  
-Carton

### Modification History:

---

REV.	Date	Content
00	2019/3/14	
01	2019/5/9	線長290mm更改為200mm，更改電氣值

REV	ZONE	DESCRIPTION	ENG	APPROVED	DATE
01	2C 4C	線長290mm更改為200mm, 更改電氣值	Mango	Ian	2019/5/9
02	B3 C2	新增I-PEX 替代零件, 修改圖面標示	Doris	Tony	2021/02/01

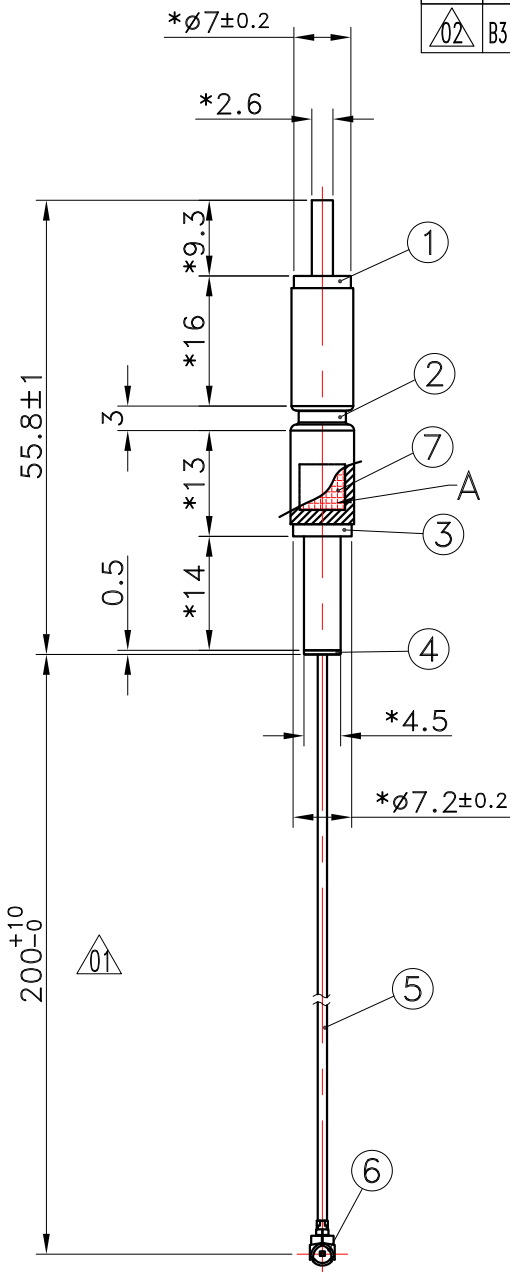

DETAIL : A/A  
SCALE : 1/1

Electrical Properties		
Frequency Range	2.4~2.5 GHz	5.15~5.85 GHz
Impedance	50Ω	
V.S.W.R.	<2.5	
Radiation	Omni	
Polarization	Vertical	
Mechanical Properties		
Whip	Brass	
Connector	Brass	
Operating Temp	-20°C~+65°C	

ITEM	Name	Material	Finish	QTY
⑦	Double Side Tape	7 * 7 mm	-	1
⑥	Mini PCI	Brass	Ni/Gold	1
⑤	Cable	ø1.13 Low Loss	Gray	1
④	Latter Plug	PA66	White	1
③	Copper Tube	Brass	Ni	1
②	Heat Shrink Tube	ø8*30L	Black	1
①	Copper Tube	Brass	Ni	1

NOTES:  
1.\*為重點尺寸

UNLESS OTHERWISE SPECIFIED TOLERANCES ON : ±0.5	DATE: 2020/04/27	MAT'L:	 <b>權億科技股份有限公司</b> Master Wave Technology Co., Ltd.	
	UNIT: mm	FINISH:		
THIRD ANGLE PROJECTION 	SCALE: 1/1	TITLE : 2+5G銅管天線		
APPROVED BY:	CHECKED BY:	DESIGNED BY: Ian	DRAWN BY: Mango	WEIGHT:
MODEL NO. : 907X00747X35		PART NO. :		REV: 02

THIS DRAWING CONTAINS INFORMATION THAT IS PROPRIETARY TO MASTER WAVE AND SHOULD NOT BE USED WITHOUT WRITTEN PERMISSION.



## Electrical Test (裸測)

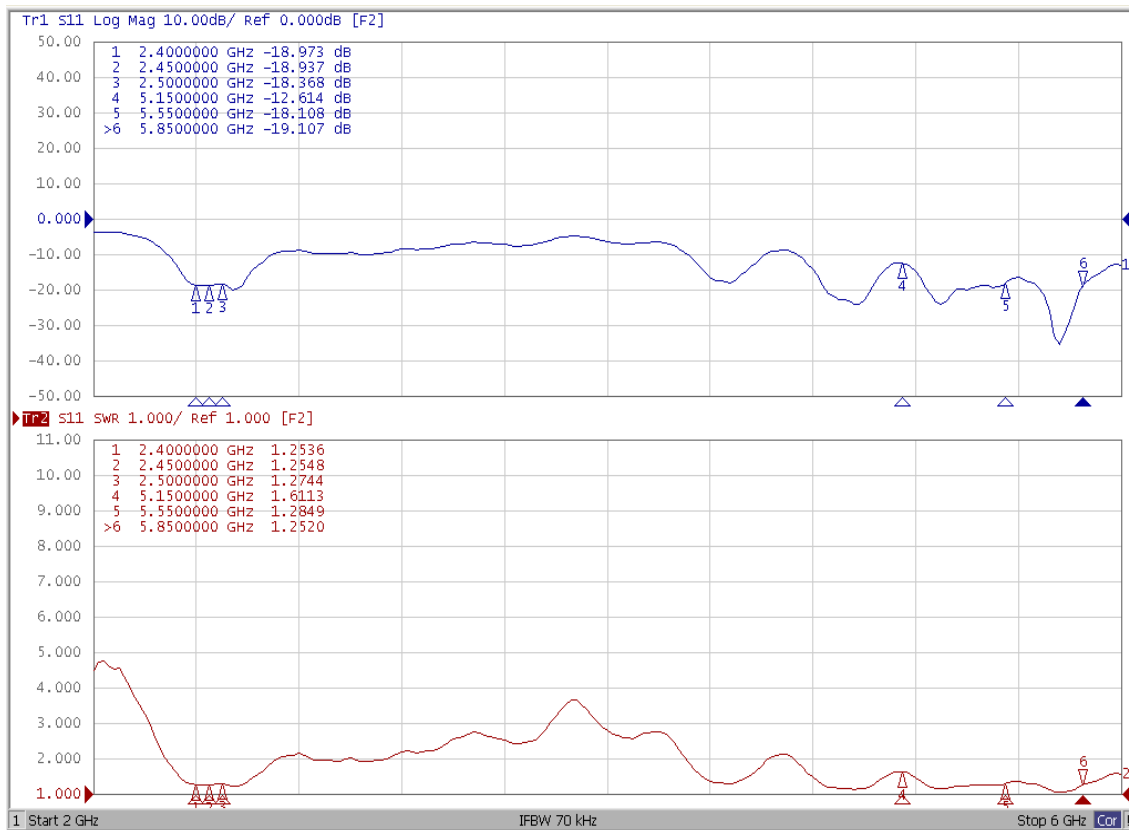



## Antenna Efficiency (裸測)

---

Frequency(MHz)	2400	2450	2500
Efficiency (%)	72%	74%	71%
Peak Gain (dBi)	1.42	1.61	1.47



## 2D Radiation Pattern-2G xy ( $\theta = 90^\circ$ )

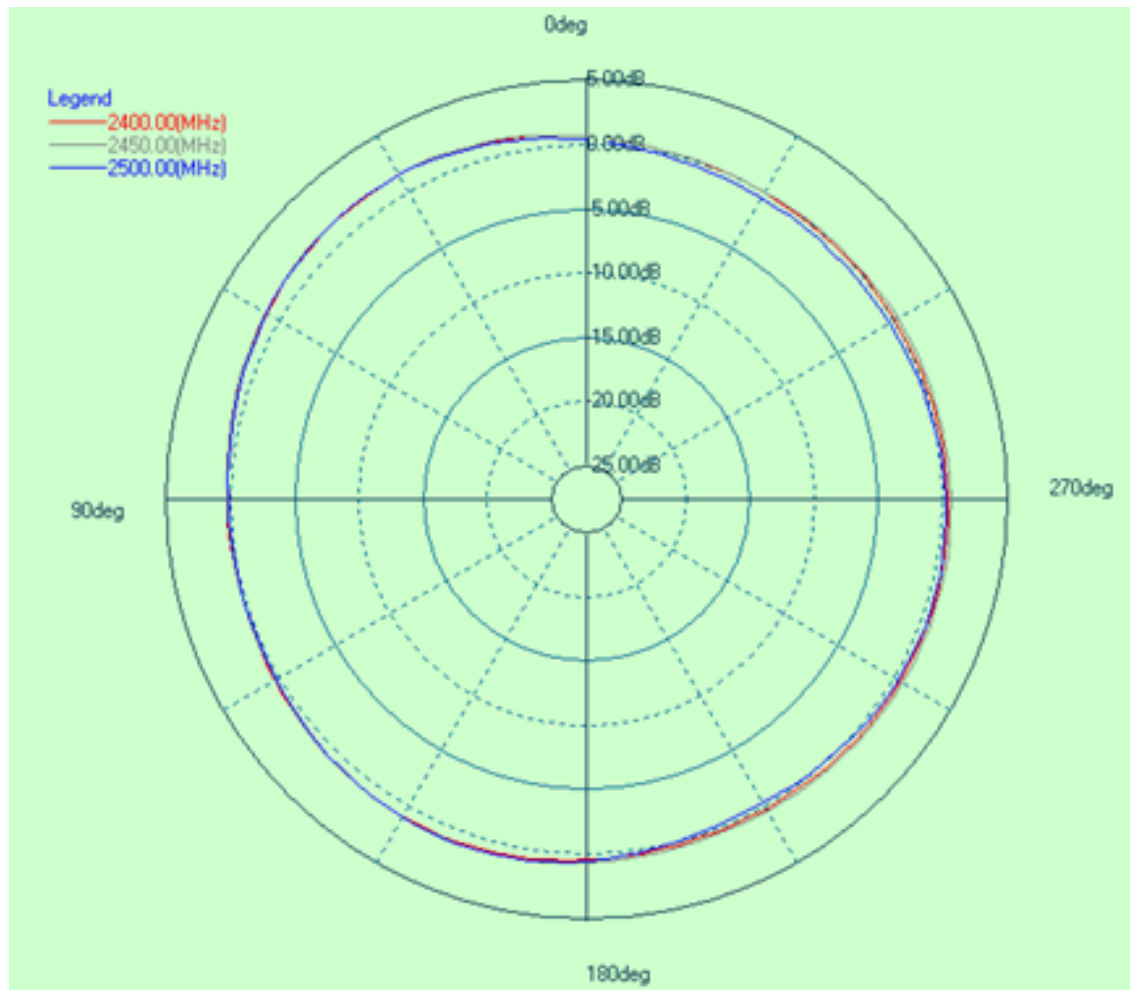



## 2D Radiation Pattern-2G xz ( $\phi = 0^\circ$ )

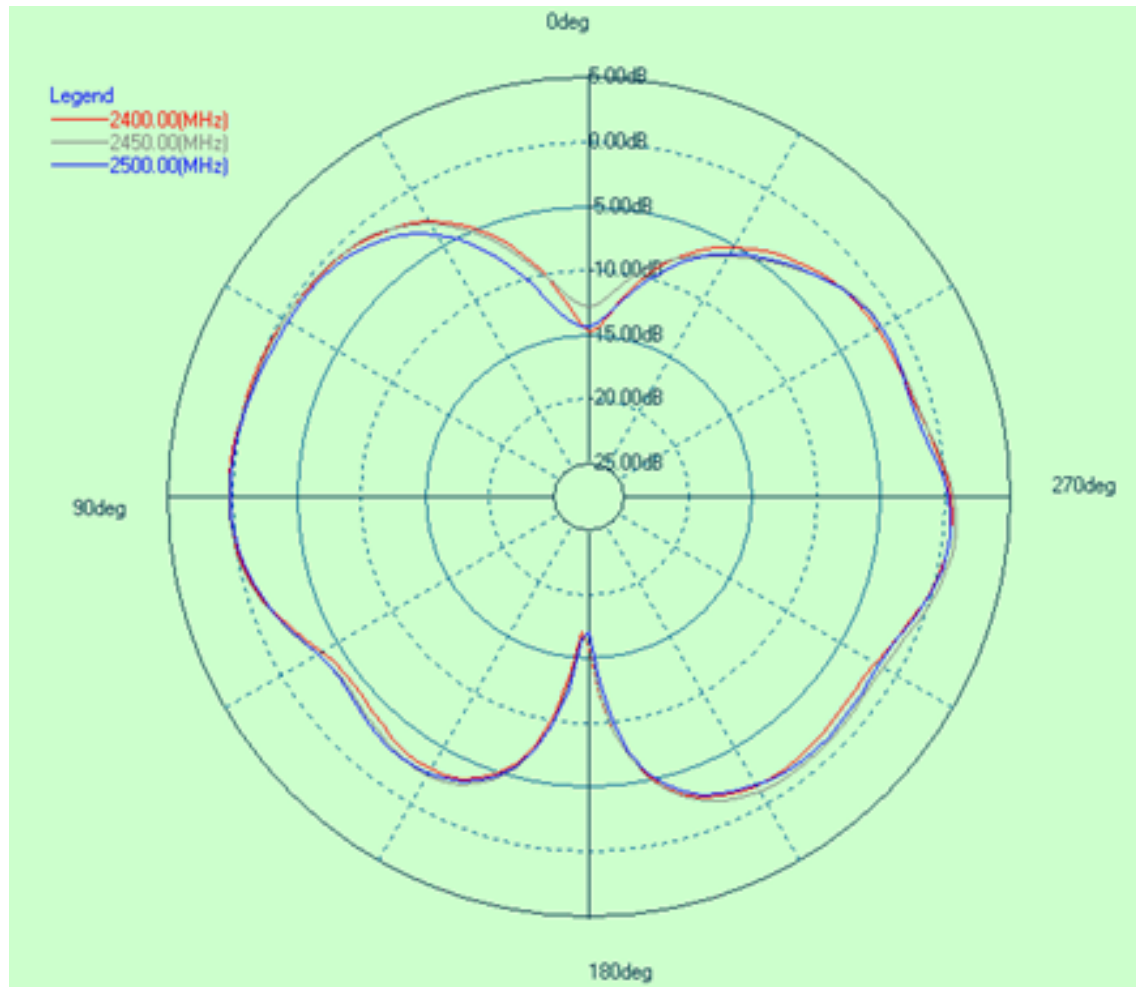



## 2D Radiation Pattern-2G yz ( $\phi = 90^\circ$ )

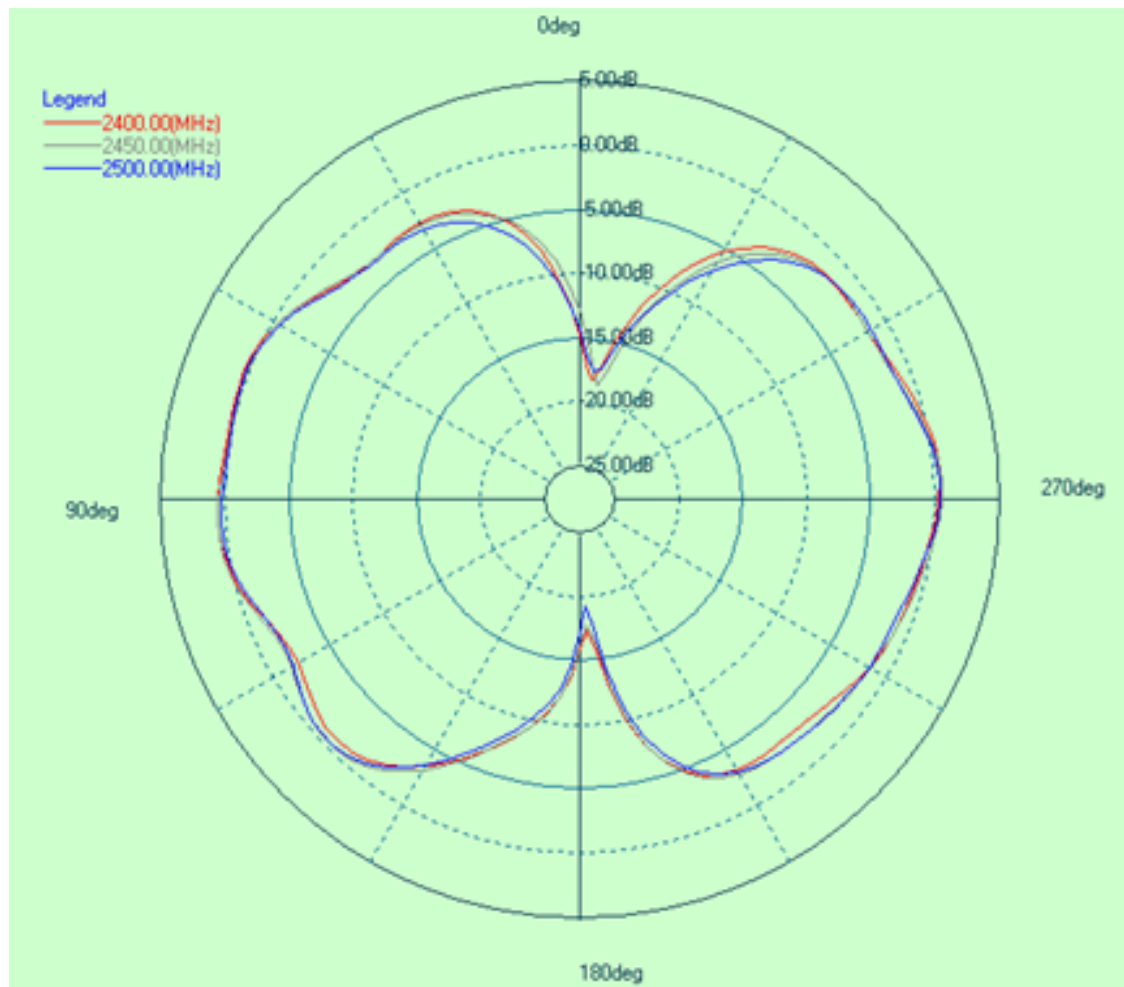





## Antenna Efficiency (裸測)

---

Frequency(MHz)	5150	5550	5850
Efficiency (%)	65%	66%	66%
Peak Gain (dBi)	2.03	2.02	2.33



## 2D Radiation Pattern-5G xy ( $\theta = 90^\circ$ )

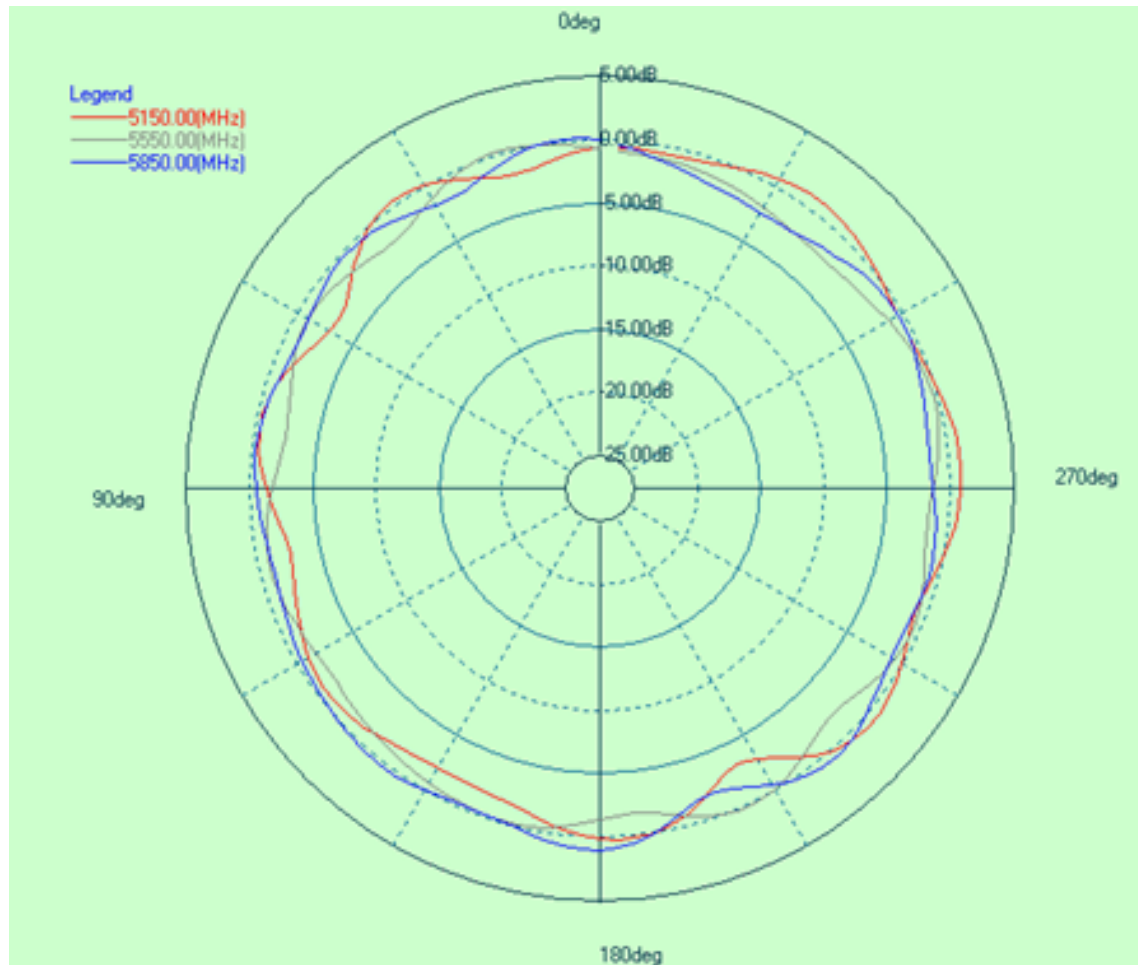



## 2D Radiation Pattern-5G xz ( $\phi = 0^\circ$ )

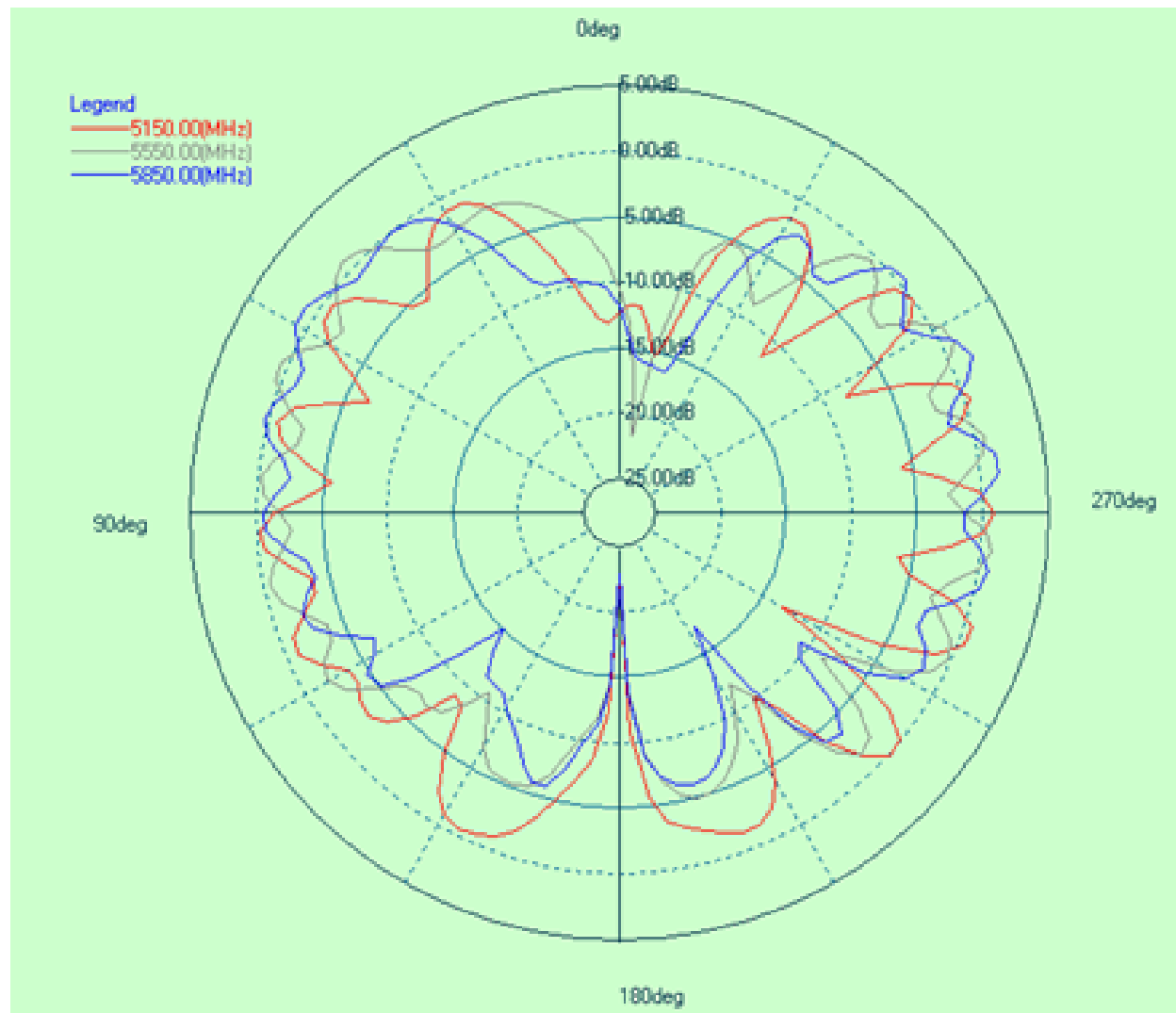



## 2D Radiation Pattern-5G yz ( $\phi = 90^\circ$ )

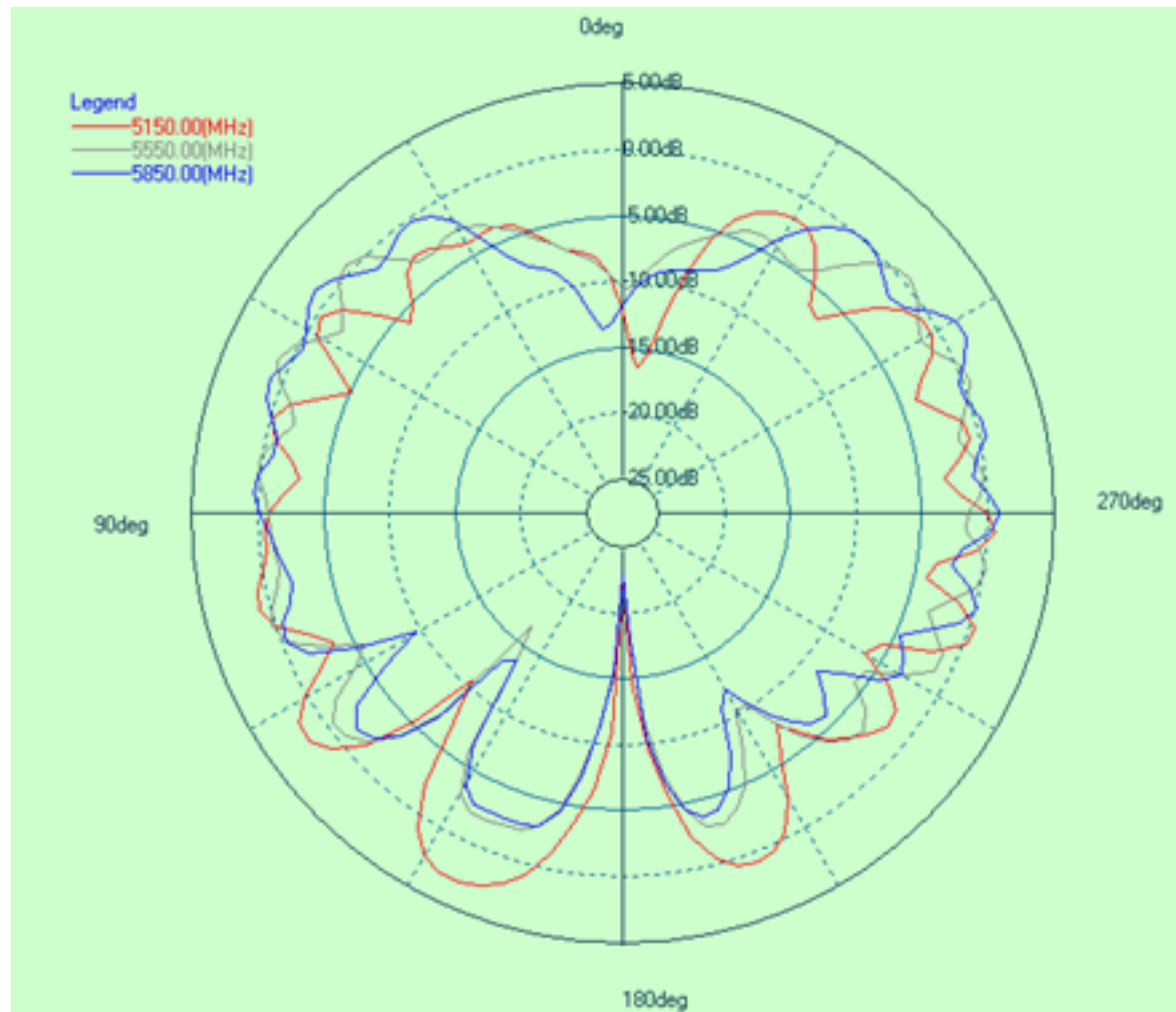

Recommended P/N

20670-001R-\*\*

PART No.  
20670-001R-\*\*

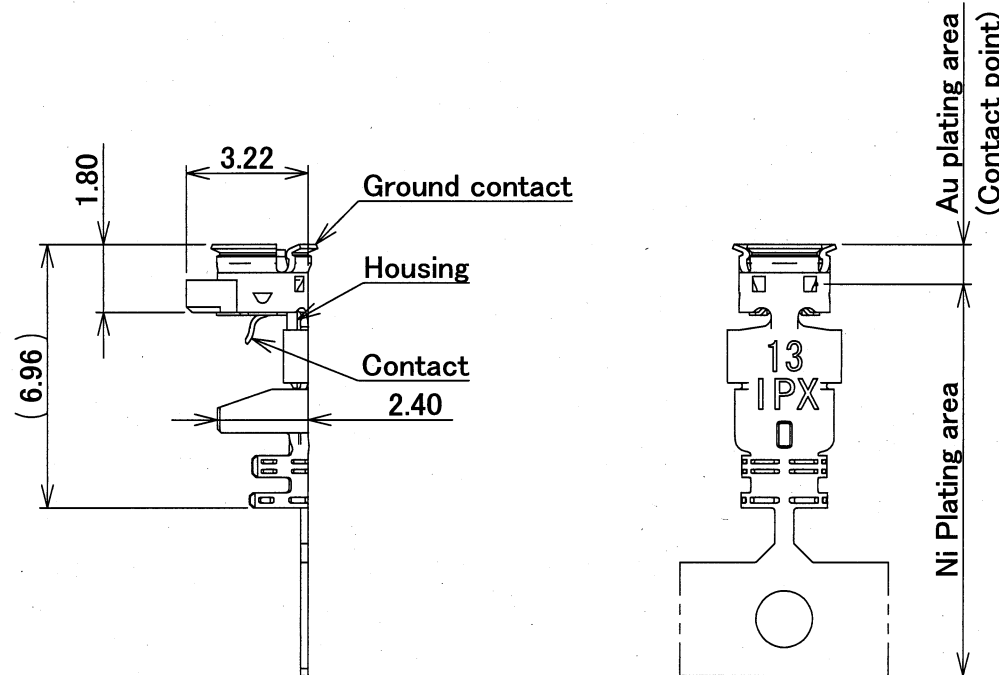
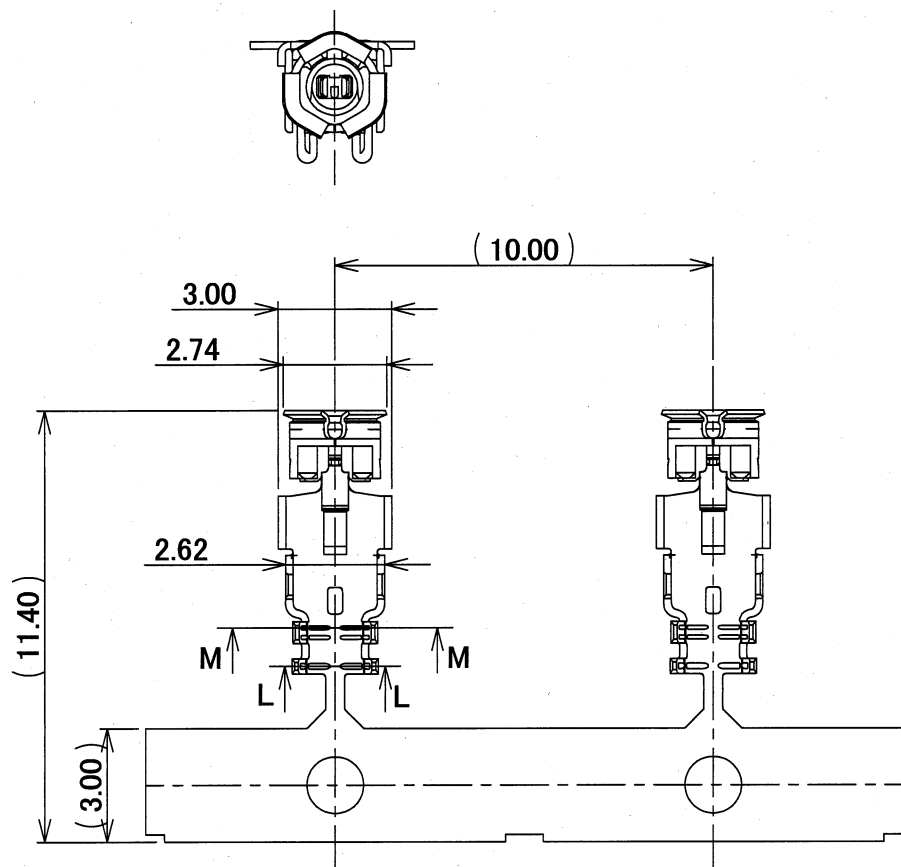

Part No. 20670-001R-08  
20670-001R-13  
20670-001R-32  
For semi auto termination machine

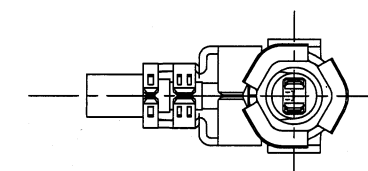
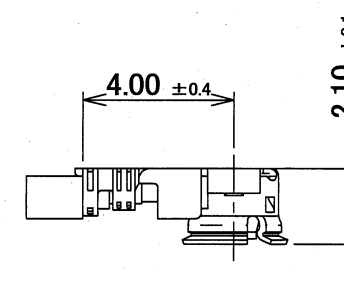
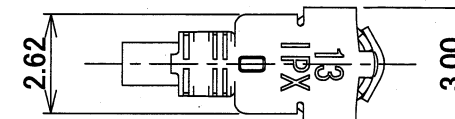

Cable Ass'y

Plug  
20670-001R-08  
20670-001R-13  
20670-001R-32

Coaxial cable

Receptacle  
Part No. 20279-001E-\*\*  
20441-001E-01

2.50 MAX

MATING

GENERAL TOLERANCE	
6 MAX.	±0.2
6 OVER MAX. 30	±0.3
30 OVER MAX. 120	±0.5
ANGLE	±2°

DESIGN'D BY <i>T. Yuzuki</i>	DATE Aug. 18/15			
CHK'D BY <i>T. Yuzuki</i>	DATE Aug. 20/15			
APP'D BY <i>T. Takano</i>	DATE Aug. 20/15			
REV	ECN	BY	DATE	APP
0	Z150889	Tad	Aug/18/'15	
REV. RECORD				
SERIES No.		R0		
CUSTOMER COPY		PROJECTION		

**I-PEX** DAI-ICHI SEIKO CO., LTD.  
I-PEX Business Company

TITLE		MHF PLUG ASS'Y	
SCALE	UNIT	DWG. No.	SHEET
5:1	mm	20670	1/6
REV.			0

Confidential III C

QKE-DFE06-02 REV.7

PART No.
20670-001R-18

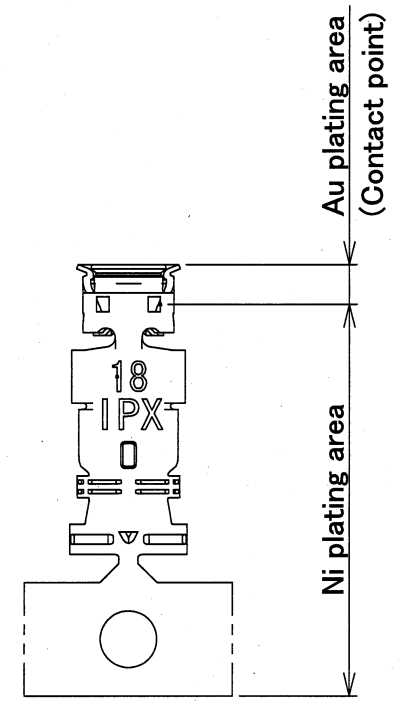
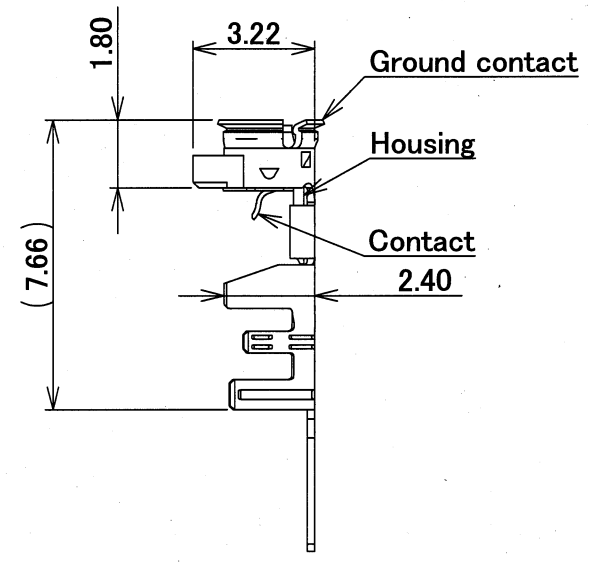
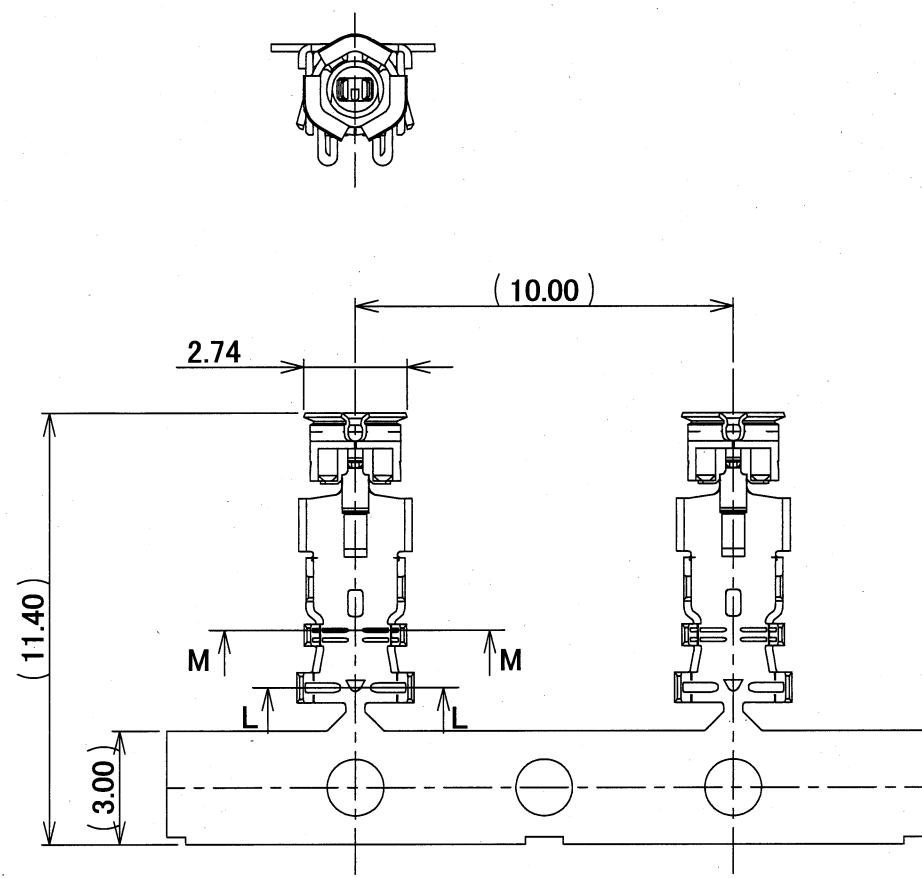

Part No. 20670-001R-18  
For semi auto termination machine

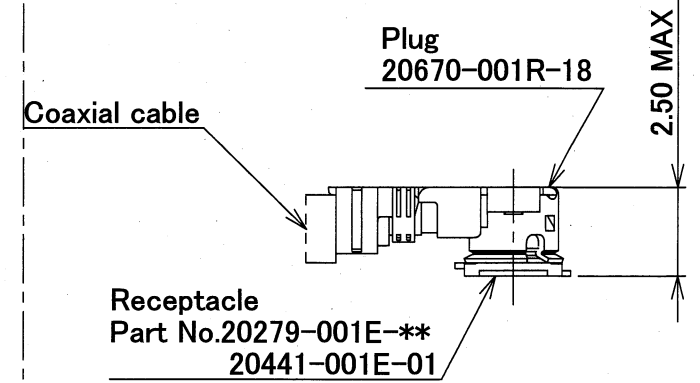
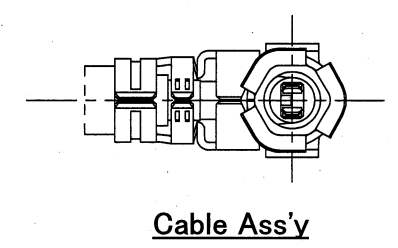
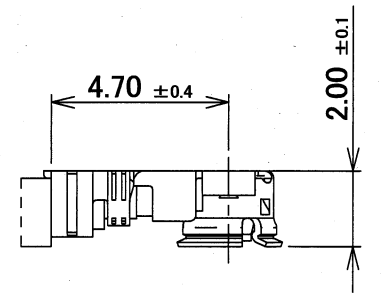
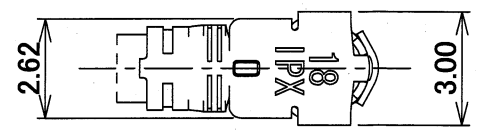

MATING

GENERAL TOLERANCE	
6 MAX.	±0.2
6 OVER MAX. 30	±0.3
30 OVER MAX. 120	±0.5
ANGLE	±2°

DESIGN'D BY	DATE
CHK'D BY	DATE
APP'D BY	DATE
CUSTOMER COPY	PROJECTION

<b>I-PEX</b> DAI-ICHI SEIKO CO.,LTD. I-PEX Business Company	
TITLE MHF PLUG ASS'Y	
SCALE 5:1	UNIT mm
DWG. No. 20670	SHEET 2/6
REV. 0	

Recommended P/N

20670-001R-\*\*-\*\*

PART No.

20670-001R-37

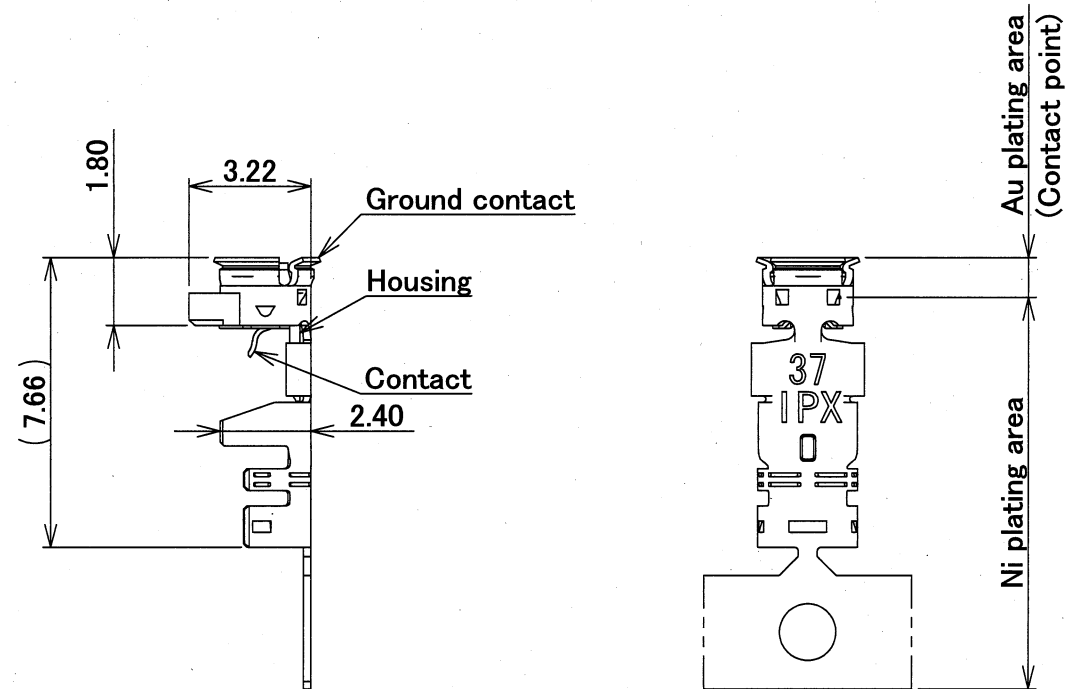
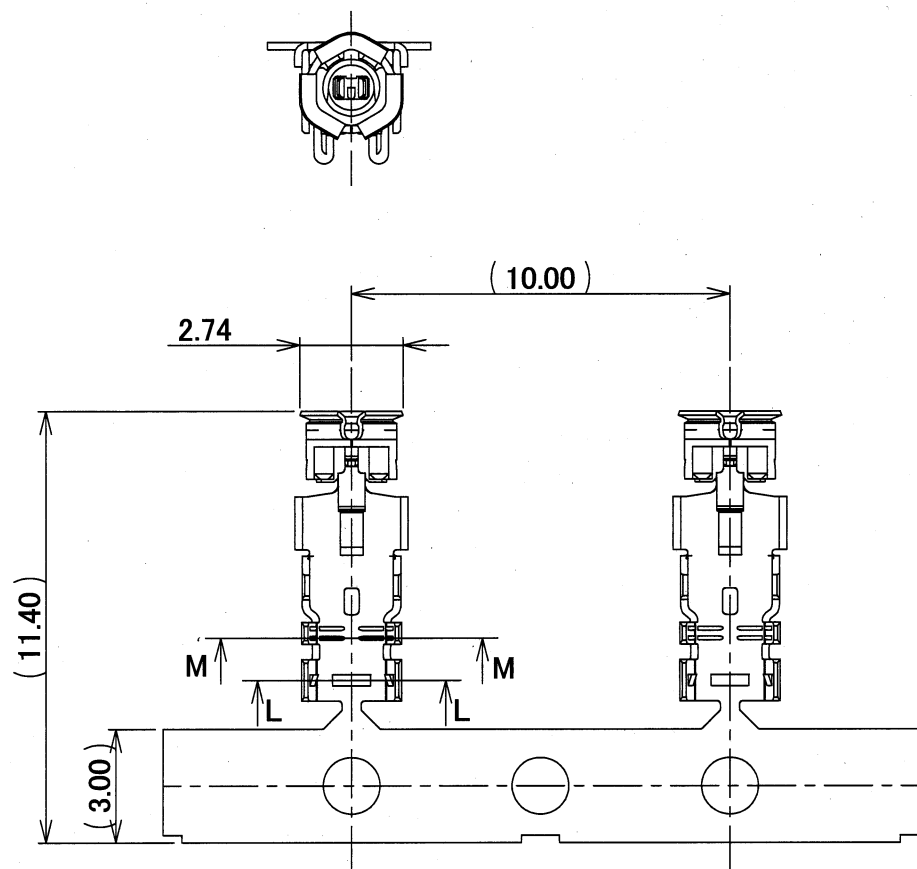

Part No. 20670-001R-37  
For semi auto termination machine

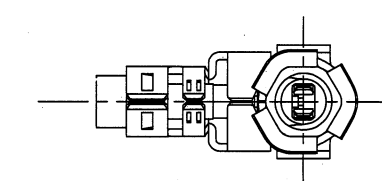
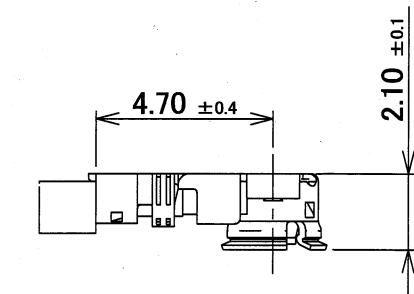
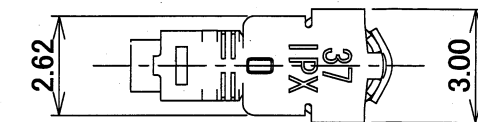

Cable Ass'y

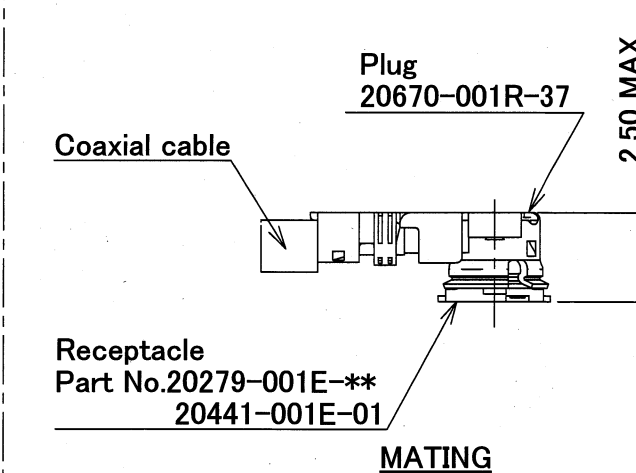

GENERAL TOLERANCE	
6 MAX.	±0.2
6 OVER MAX. 30	±0.3
30 OVER MAX. 120	±0.5
ANGLE	±2°

DESIGN'D BY	DATE
CHK'D BY	DATE
APP'D BY	DATE
CUSTOMER COPY	PROJECTION

**I-PEX** DAI-ICHI SEIKO CO.,LTD.  
I-PEX Business Company

TITLE		SCALE	UNIT	DWG. No.	SHEET	REV.
MHF PLUG ASS'Y		5:1	mm	20670	3/6	0

Confidential III C

QKE-DFE06-02 REV.7

Part No.	20670-001R-08	20670-001R-13	20670-001R-32	20670-001R-18	Cable cut length
Housing color	Black	Black	Black	Black	
Applicable cable nominal dimension	 2.09 ±0.1 1.25 ±0.1 1.16 ±0.1 AWG#36(7/0.05) ※ NOTE-1	 2.09 ±0.1 1.25 ±0.1 1.16 ±0.1 AWG#32(7/0.08) ※ NOTE-1	 2.09 ±0.1 1.25 ±0.1 1.16 ±0.1 AWG#32(7/0.08) ※ NOTE-1	 2.09 ±0.1 1.25 ±0.1 1.16 ±0.1 AWG#30(7/1.02) ※ NOTE-1	
Braided shield of Outer conductor 外部導体の編組	Single / 1重編組	Single / 1重編組	Double / 2重編組	Single / 1重編組	
P/N of semi auto termination machine	90213-008C	90213-013C	90213-032C	90232-018	
Sect. M-M					
Sect. L-L					
Crimp Height	CH-1	1.34~1.40	1.34~1.40	1.34~1.40	
	CH-2	0.76~0.84	1.06~1.14	1.20~1.30	
	CH-3	0.85~0.97	1.15~1.35	1.26~1.46	

Note-1  
 中心導体、外部導体への半田コーティングは不可  
 Must not use solder coated inner conductor and outer conductor.

GENERAL TOLERANCE	
6 MAX.	±0.2
6 OVER MAX. 30	±0.3
30 OVER MAX. 120	±0.5
ANGLE	±2°

DESIGN'D BY	DATE
CHK'D BY	DATE
APP'D BY	DATE
CUSTOMER COPY	PROJECTION

**I-PEX** DAI-ICHI SEIKO CO.,LTD.  
 I-PEX Business Company

TITLE	MHF PLUG ASS'Y	
SCALE	UNIT	DWG. No.
---	mm	20670
SHEET	REV.	
4/6	0	



Part No.		20670-001R-37	
Housing color		Black	
Applicable cable nominal dimension			
Braided shield of Outer conductor 外部導体の編組		Single / 1重編組	
P/N of semi auto termination machine		90232-037	
Sect. M-M			
Sect. L-L			
Crimp Height	CH-1	1.34~1.40	
	CH-2	1.14~1.20	
	CH-3	1.34~1.40	

※ NOTE-1

Cable cut length

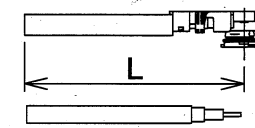

Crimp Height  
Blade Micrometer

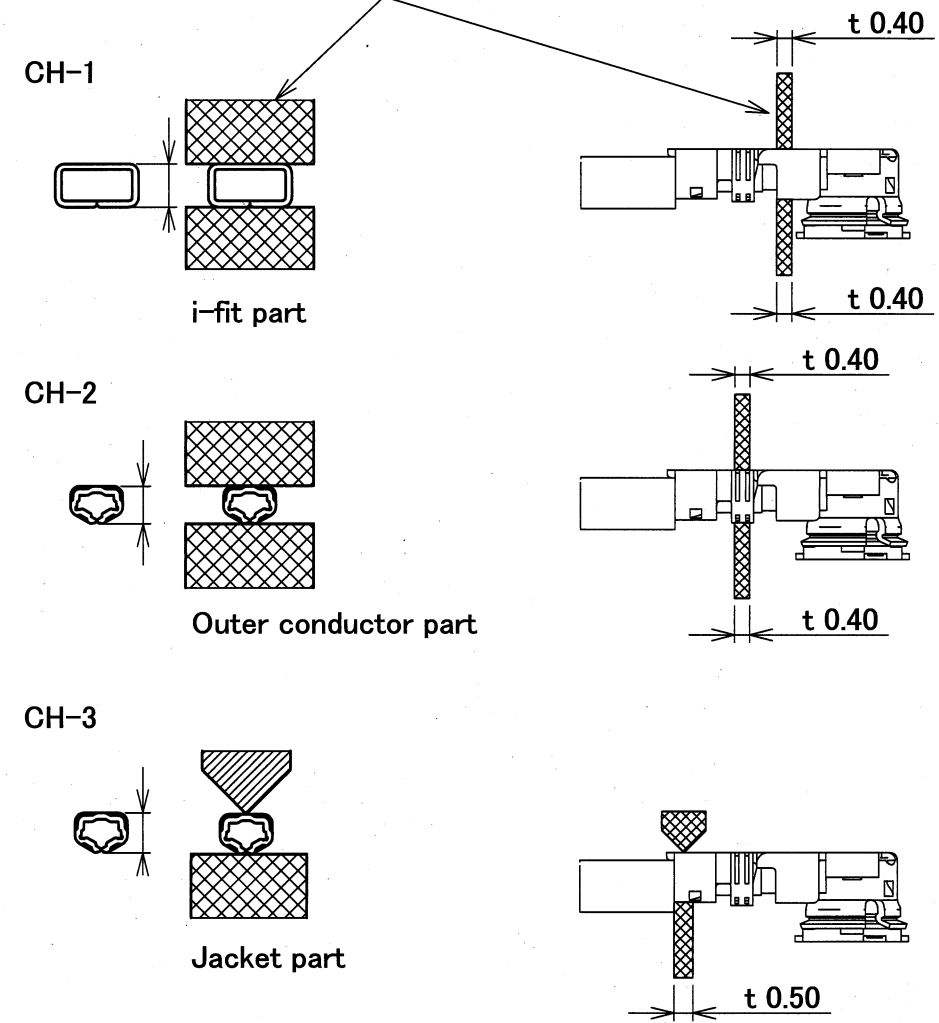

Notes.

1. Must not use solder coated inner conductor and outer conductor.

GENERAL TOLERANCE	
6 MAX.	±0.2
6 OVER MAX. 30	±0.3
30 OVER MAX. 120	±0.5
ANGLE	±2°

Confidential III C

DESIGN'D BY	DATE			TITLE			
CHK'D BY	DATE						
APP'D BY	DATE						
CUSTOMER COPY		PROJECTION	SCALE	UNIT	DWG. No.	SHEET	REV.
			---	mm	20670	5/6	0

Notes

1. Material  
 (1) Housing : PBT , UL94V-0  
 (2) Contact  
 Phosphor Bronze : Au over Ni  
 (3) Ground contact  
 Phosphor Bronze : Au over Ni  
 Au plating area : Au over Ni  
 Ni plating area : Ni only  
 2. Packing : Reel  
 3. Mating partner part No.  
 : 20279-001E-\*\*, 20441-001E-01  
 4. Permissible load of cable at mating

1. コネクタの材料  
 (1) ハウジング : PBT, UL94V-0  
 (2) コンタクト  
 リン青銅 : 金メッキ、下地 ニッケルメッキ  
 (3) グランドコンタクト  
 リン青銅  
 金メッキエリア : 金メッキ、下地 ニッケルメッキ  
 ニッケルメッキエリア : ニッケルメッキ  
 2. 梱包 : リール  
 3. かん合相手 Part No.  
 : 20279-001E-\*\*, 20441-001E-01  
 4. コネクタかん合後のケーブルに対する荷重

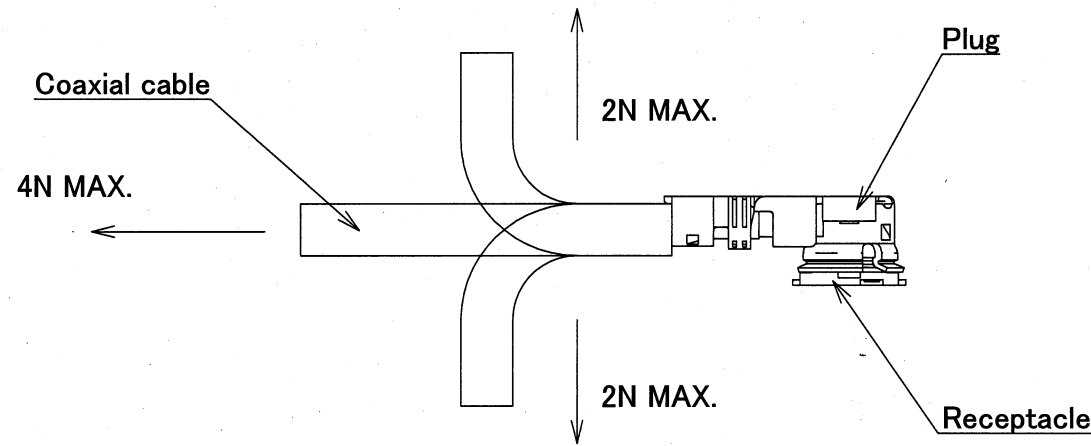

5. Suggestions for mating & unmating operation.  
 5-1 Mating.  
 Please mate the connector straightly to vertical direction as much as possible, adjusting the mating axis of plug and receptacle. As excessive slant angle mating may break the connector, please don't do it.

5. コネクタかん合時および抜去時の注意  
 5-1 コネクタ挿入時  
 PlugとReceptacleのかん合軸を合わせ、できるだけ垂直に挿入して下さい。極端な斜め挿入は行わないで下さい。コネクタ破損の原因となりますので、過度なこじり挿抜は行わないで下さい。

5-2 Unmating.

- (1) In case of unmating by pulling tool. Please use the pulling tool as the following drawing, and please pull plug to vertical direction as directly as possible.

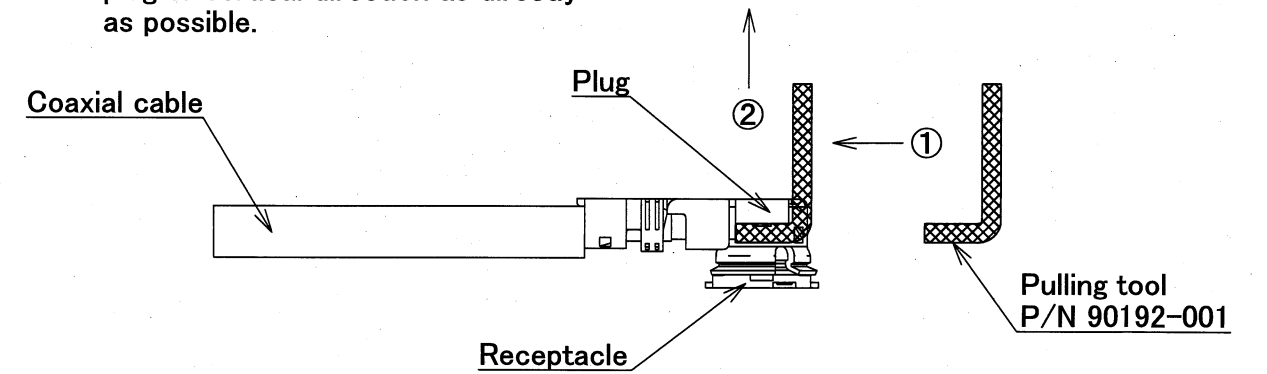

5-2 コネクタ抜去時

- (1) 抜去ジグを用いる場合  
 下図のようにできるだけ垂直に引き抜いて下さい。

- (2) In case of unmating directly by hand. Please catch the catching area of plug, and please pull plug to vertical direction as directly as possible.

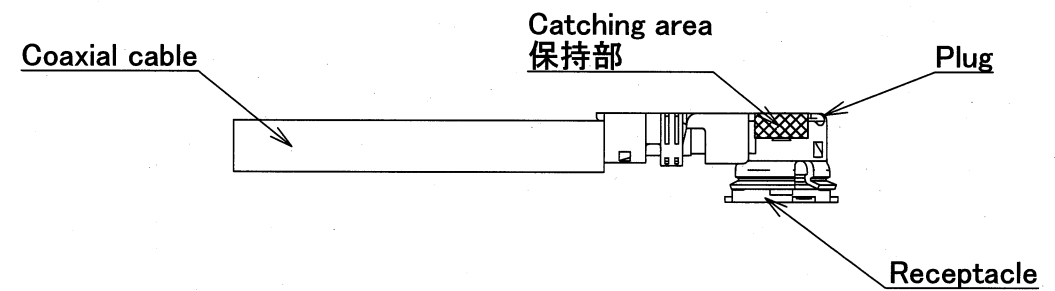

- (2) 手で直接引き抜く場合  
 下図の保持部をつかみ、できるだけ垂直に引き抜いて下さい。

5-3 Crimp over standards of outer conductor

Standards : Less than 10% from total numbers of outer conductor (Numbers of outer conductor's crimp over from outer conductor's barrel)

5-3 外部導体はみ出し量

外部導体はみ出し量規定 : 外部導体トータル本数の10%以下 (外部導体バレルの外にはみ出した量)

5-4 Caution about Heat shrinkage tubes

Please be careful not to melt housing when using heat shrinkage tubes. It will become cause of open circuit.

5-4 熱収縮チューブについての注意

熱収縮チューブで外部導体を覆う場合は、導通不良の原因になりますので、熱によりハウジングを溶融させないよう注意してください。

6. This is "Pb-free" connector.

6. 本コネクタは"Pb-free"である

GENERAL TOLERANCE	
6 MAX.	±0.2
6 OVER MAX. 30	±0.3
30 OVER MAX. 120	±0.5
ANGLE	±2°

DESIGN'D BY	DATE	<b>DAI-ICHI SEIKO CO.,LTD.</b> I-PEX Business Company	TITLE					
CHK'D BY	DATE		MHF PLUG ASS'Y					
APP'D BY	DATE		CUSTOMER COPY	PROJECTION	SCALE	UNIT	DWG. No.	SHEET
				---	mm	20670	6/6	0







線材規格

CABLE SPECIFICATION

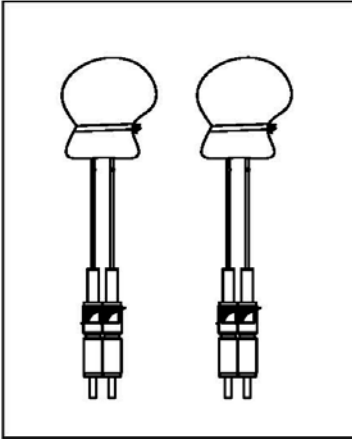
SPECIFICATION: 1.13mm CABLE (Low Loss)		CONSTRUCTION D.W.G	
ITEM	SPECIFICATION		
CONDUCTOR	MATERIAL	Silver-coated Copper Wire	
	Composition(No./mm)	7/0.080	
	NOM.O.D(mm)	0.24±0.02	
INSULATION	Material	FEP(Natural)	
	Nom.Thick.(mm)	0.24	
	NOM.O.D(mm)	0.73±0.03	
TAPE	MATERIAL	Copper Mylar Tape	
BRAID	Composition(mm)	Vertical Wrapping the Copper Mylar Tape of 0.015	
	MATERIAL	Tinned annealed copper wire	
	Composition(mm)	Single Braid of 0.05	
JACKET	MATERIAL	FEP(*color)	
	Nom.Thick(mm)	0.1	
	Nom.O.D(mm)	1.18±0.05	
Color		According to corresponding have approved by the suppliers and customers	
<b>Electrical Properties(at 20°C)</b>			
Item	Unit	Details	
Conductor Resistance	Ω/km	Max.581	
Insulation Resistance	MΩ.km	Min.500	
Dielectric Strength	V(AC)/min	500	
Capacitance	pF/m	98(1kHz)	
<b>REMARK</b>			
<b>MASTER WAVE TECHNOLOGY CO., LTD.</b>			
CHECKED	Charlene	DATE	2013/5/22
DRAWING		REV	00
Characteristic Impedance	Ω	50±2.0	
Attenuation	dB/m	1GHz	1.75
		2GHz	2.35
		3GHz	2.90
		4GHz	3.45
		5GHz	3.80
6GHz	4.35		
Temperature range	°C	-55~200	
Standing wave(0-6GHz)	I	≦1.30	
Rating Voltage	V	30	

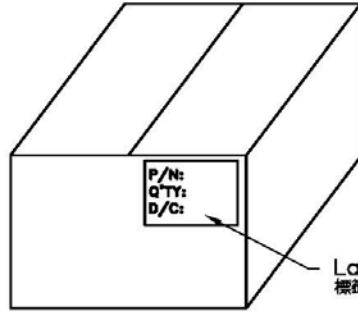

4	3	2	1
REV		ZONE	DESCRIPTION
ENG		APPROVED	DATE
F			F
E			E
D	<p>25PCS ANTENNA / 綁一束 50PCS ANTENNA / 1PE BAG</p>		D
C			C
B			B
A	<p>Label 標籤Label貼於外箱側面</p>		A
DATE:		MAT'L:	
UNIT: mm		FINISH:	
THIRD ANGLE PROJECTION 		SCALE: -	
APPROVED BY:		DRAWN BY:	
CHECKED BY:		DESIGNED BY:	
		MODEL NO. :	
		PART NO. :	
		REV	
		00	
THIS DRAWING CONTAINS INFORMATION THAT IS PROPRIETARY TO MASTER WAVE AND SHOULD NOT BE USED WITHOUT WRITTEN PERMISSION.			
4	3	2	1