

# TEST REPORT (SPOT CHECK)

## CERTIFICATE OF CONFORMITY

**Standard:** 47 CFR FCC Part 15, Subpart E (Section 15.407)

**Report No.:** RFBBQZ-WTW-P21120286A-1

**FCC ID:** PY323200597

**Referenced FCC ID:** PY322100553

**Product:** Wireless Module

**Brand:** NETGEAR

**Model No.:** MB12X

**Received Date:** 2023/5/11

**Test Date:** 2023/5/30 ~ 2023/6/7

**Issued Date:** 2023/6/17

**Applicant and  
Manufacturer:** NETGEAR, Inc.

**Address:** 350 East Plumeria Drive San Jose, CA 95134

**Issued By:** Bureau Veritas Consumer Products Services (H.K.) Ltd., Taoyuan Branch  
Hsin Chu Laboratory

**Lab Address:** E-2, No.1, Li Hsin 1st Road, Hsinchu Science Park, Hsinchu City 300, Taiwan

**Test Location:** E-2, No.1, Li Hsin 1st Road, Hsinchu Science Park, Hsinchu City 300, Taiwan

**FCC Registration /** 723255 / TW2022

**Designation Number:**

**Approved by:** \_\_\_\_\_



May Chen / Manager

**Date:** \_\_\_\_\_

2023/6/17

This test report consists of 32 pages in total. It may be duplicated completely for legal use with the approval of the applicant. It should not be reproduced except in full, without the written approval of our laboratory. The test results in the report only apply to the tested sample. The test results in this report are traceable to the national or international standards.

Prepared by : Phoebe Wang / Specialist



This report is governed by, and incorporates by reference, the Conditions of Testing as posted at the date of issuance of this report at <http://www.bureauveritas.com/home/about-us/our-business/cps/about-us/terms-conditions/> and is intended for your exclusive use. Any copying or replication of this report to or for any other person or entity, or use of our name or trademark, is permitted only with our prior written permission. This report sets forth our findings solely with respect to the test samples identified herein. The results set forth in this report are not indicative or representative of the quality or characteristics of the lot from which a test sample was taken or any similar or identical product unless specifically and expressly noted. Our report includes all of the tests requested by you and the results thereof based upon the information that you provided to us. Measurement uncertainty is only provided upon request for accredited tests. Statements of conformity are based on simple acceptance criteria without taking measurement uncertainty into account, unless otherwise requested in writing. You have 60 days from date of issuance of this report to notify us of any material error or omission caused by our negligence or if you require measurement uncertainty; provided, however, that such notice shall be in writing and shall specifically address the issue you wish to raise. A failure to raise such issue within the prescribed time shall constitute your unqualified acceptance of the completeness of this report, the tests conducted and the correctness of the report contents.

## Table of Contents

<b>Release Control Record .....</b>	<b>3</b>
<b>1 Certificate.....</b>	<b>4</b>
<b>2 Summary of Test Results .....</b>	<b>5</b>
2.1 Measurement Uncertainty .....	5
2.2 Supplementary Information .....	5
<b>3 General Information .....</b>	<b>6</b>
3.1 General Description of EUT .....	6
3.2 Antenna Description of EUT .....	7
3.3 Channel List.....	8
3.4 Test Mode Applicability and Tested Channel Detail.....	9
3.5 Duty Cycle of Test Signal.....	10
3.6 Test Program Used and Operation Descriptions .....	11
3.7 Connection Diagram of EUT and Peripheral Devices .....	11
3.8 Configuration of Peripheral Devices and Cable Connections .....	12
<b>4 Test Instruments .....</b>	<b>13</b>
4.1 RF Output Power.....	13
4.2 AC Power Conducted Emissions .....	13
4.3 Unwanted Emissions below 1 GHz .....	14
4.4 Unwanted Emissions above 1 GHz.....	15
<b>5 Limits of Test Items.....</b>	<b>16</b>
5.1 RF Output Power.....	16
5.2 AC Power Conducted Emissions .....	16
5.3 Unwanted Emissions below 1 GHz .....	16
5.4 Unwanted Emissions above 1 GHz.....	17
<b>6 Test Arrangements.....</b>	<b>18</b>
6.1 RF Output Power.....	18
6.1.1 Test Setup .....	18
6.1.2 Test Procedure.....	18
6.2 AC Power Conducted Emissions .....	18
6.2.1 Test Setup .....	18
6.2.2 Test Procedure.....	18
6.3 Unwanted Emissions below 1 GHz .....	19
6.3.1 Test Setup .....	19
6.3.2 Test Procedure.....	20
6.4 Unwanted Emissions above 1 GHz.....	21
6.4.1 Test Setup .....	21
6.4.2 Test Procedure.....	21
<b>7 Test Results of Test Item .....</b>	<b>22</b>
7.1 RF Output Power.....	22
7.2 AC Power Conducted Emissions .....	24
7.3 Unwanted Emissions below 1 GHz .....	26
7.4 Unwanted Emissions above 1 GHz.....	28
<b>8 Pictures of Test Arrangements .....</b>	<b>31</b>
<b>9 Information of the Testing Laboratories .....</b>	<b>32</b>



## Release Control Record

Issue No.	Description	Date Issued
RFBBQZ-WTW-P21120286A-1	Original release.	2023/6/17

## 1 Certificate

**Product:** Wireless Module  
**Brand:** NETGEAR  
**Test Model:** MB12X  
**Sample Status:** Engineering sample  
**Applicant:** NETGEAR, Inc.  
**Test Date:** 2023/5/30 ~ 2023/6/7  
**Standard:** 47 CFR FCC Part 15, Subpart E (Section 15.407)  
**Measurement procedure:** ANSI C63.10-2013  
KDB 789033 D02 General UNII Test Procedure New Rules v02r01  
KDB 662911 D01 Multiple Transmitter Output v02r01

The above equipment has been tested by **Bureau Veritas Consumer Products Services (H.K.) Ltd., Taoyuan Branch**, and found compliance with the requirement of the above standards. The test record, data evaluation & Equipment Under Test (EUT) configurations represented herein are true and accurate accounts of the measurements of the sample's RF characteristics under the conditions specified in this report.

## 2 Summary of Test Results

47 CFR FCC Part 15, Subpart E (Section 15.407)			
Clause	Test Item	Result	Remark
15.407(a)(2)	26 dB Bandwidth	NA	Refer to Note 1 below
15.407(a)(1) 15.407(a)(3)	RF Output Power	Pass	Meet the requirement of limit.
15.407(a)(1) 15.407(a)(3)	Power Spectral Density	NA	Refer to Note 1 below
15.407(e)	6 dB Bandwidth	NA	Refer to Note 1 below
---	Occupied Bandwidth	-	Reference only.
15.407(g)	Frequency Stability	NA	Refer to Note 1 below
15.407(b)(9)	AC Power Conducted Emissions	Pass	Minimum passing margin is -6.56 dB at 0.36159 MHz
15.407(b)(9)	Unwanted Emissions below 1 GHz	Pass	Minimum passing margin is -4.1 dB at 46.00 MHz
15.407(b) (1/10) 15.407(b) (4(i)/10)	Unwanted Emissions above 1 GHz	Pass	Minimum passing margin is -0.3 dB at 5650.00 MHz
15.203	Antenna Requirement	Pass	Antenna connector is ipex(MHF) not a standard connector.

### Note:

1. RF Output Power, AC Power Conducted Emissions & Unwanted Emissions was performed for this addendum. The others testing data refer to original test report.
2. Determining compliance based on the results of the compliance measurement, not taking into account measurement instrumentation uncertainty.

### 2.1 Measurement Uncertainty

Where relevant, the following measurement uncertainty levels have been estimated for tests performed on the EUT as specified in CISPR 16-4-2:

Measurement	Specification	Expanded Uncertainty (k=2) (±)
AC Power Conducted Emissions	150 kHz ~ 30 MHz	1.9 dB
Unwanted Emissions below 1 GHz	9 kHz ~ 30 MHz	3.1 dB
	30 MHz ~ 1 GHz	5.5 dB
Unwanted Emissions above 1 GHz	1 GHz ~ 18 GHz	5.1 dB
	18 GHz ~ 40 GHz	5.3 dB

The other instruments specified are routine verified to remain within the calibrated levels, no measurement uncertainty is required to be calculated.

### 2.2 Supplementary Information

There is not any deviation from the test standards for the test method, and no modifications required for compliance.

### 3 General Information

#### 3.1 General Description of EUT

Product	Wireless Module
Brand	NETGEAR
Test Model	MB12X
FW Version	4.0.1_4.0.1
Status of EUT	Engineering sample
Power Supply Rating	12 Vdc
Modulation Type	64QAM, 16QAM, QPSK, BPSK for OFDM 256QAM for OFDM in 11ac mode 1024QAM for OFDMA in 11ax HE mode
Modulation Technology	OFDM, OFDMA
Transfer Rate	802.11a: up to 54 Mbps 802.11n: up to 300 Mbps 802.11ac: up to 866.7 Mbps 802.11ax: up to 1201.0 Mbps
Operating Frequency	5.18 GHz ~ 5.24 GHz 5.745 GHz ~ 5.825 GHz
Number of Channel	802.11a, 802.11n (HT20), 802.11ac (VHT20), 802.11ax (HE20): 9 802.11n (HT40), 802.11ac (VHT40), 802.11ax (HE40): 4 802.11ac (VHT80), 802.11ax (HE80): 2
Output Power	5.18 GHz ~ 5.24 GHz : 244.645 mW (23.89 dBm) 5.745 GHz ~ 5.825 GHz : 568.288 mW (27.55 dBm)
EUT Category	Client device

Note:

- Exhibit prepared for Spot Check Verification report, the format, test items and amount of spot-check test data are decided by applicant's engineering judgment, for more details please refer to the declaration letter exhibit. (Referenced FCC ID: PY322100553, Report No.: RFBBQZ-WTW-P21120286-1)
- There are WLAN (2.4 GHz & 5 GHz) and Bluetooth technology used for the EUT.
- Simultaneously transmission condition.

Condition	Technology	
1	WLAN 2.4GHz	Bluetooth
2	WLAN 5GHz	Bluetooth

Note: The emission of the simultaneous operation has been evaluated and no non-compliance was found.

- The above EUT information is declared by manufacturer and for more detailed features description, please refer to the manufacturer's specifications or User's Manual.

### 3.2 Antenna Description of EUT

1. The antenna information is listed as below.

Antenna NO.	Model	Antenna Net Gain(dBi)	Frequency range (GHz)	Antenna Type	Connector Type
MC321-Ant0	907X00747X22(580)	1.03	2.4~2.4835	Dipole	ipex(MHF)
		1.36	5.15~5.25		
		1.78	5.725~5.85		
MC321-Ant1	907X00747X11(580)	1.33	2.4~2.4835	Dipole	ipex(MHF)
		2.22	5.15~5.25		
		2.24	5.725~5.85		
MC327-Ant0	907X00747X88	0.64	2.4~2.4835	Dipole	ipex(MHF)
		1.24	5.15~5.25		
		1.51	5.725~5.85		
MC327-Ant1	907X00747X35	1.61	2.4~2.4835	Dipole	ipex(MHF)
		2.03	5.15~5.25		
		2.33	5.725~5.85		
BT	ACA-5036-A2-CC-S	2.1	2.4~2.4835	Chip	None

\* Detail antenna specification please refer to antenna datasheet and/or antenna measurement report.

2. The EUT incorporates a MIMO function:

5 GHz Band		
Modulation Mode	TX & RX Configuration	
<b>802.11a</b>	2TX	2RX
<b>802.11n (HT20)</b>	2TX	2RX
<b>802.11n (HT40)</b>	2TX	2RX
<b>802.11ac (VHT20)</b>	2TX	2RX
<b>802.11ac (VHT40)</b>	2TX	2RX
<b>802.11ac (VHT80)</b>	2TX	2RX
<b>802.11ax (HE20)</b>	2TX	2RX
<b>802.11ax (HE40)</b>	2TX	2RX
<b>802.11ax (HE80)</b>	2TX	2RX

Note:

- The modulation and bandwidth are similar for 802.11n mode for 20 MHz (40 MHz), 802.11ac mode for 20 MHz (40 MHz, 80 MHz) and 802.11ax mode for 20 MHz (40MHz, 80 MHz), therefore the manufacturer will control the power for 802.11n/ac mode is the same as the 802.11ax or more lower than it and investigated worst case to representative mode in test report.

### 3.3 Channel List

#### FOR 5180 ~ 5240 MHz

4 channels are provided for 802.11a, 802.11n (HT20), 802.11ac (VHT20), 802.11ax (HE20):

Channel	Frequency	Channel	Frequency
36	5180 MHz	44	5220 MHz
40	5200 MHz	48	5240 MHz

2 channels are provided for 802.11n (HT40), 802.11ac (VHT40), 802.11ax (HE40):

Channel	Frequency	Channel	Frequency
38	5190 MHz	46	5230 MHz

1 channel is provided for 802.11ac (VHT80), 802.11ax (HE80):

Channel	Frequency
42	5210 MHz

#### FOR 5745 ~ 5825 MHz:

5 channels are provided for 802.11a, 802.11n (HT20), 802.11ac (VHT20), 802.11ax (HE20):

Channel	Frequency	Channel	Frequency
149	5745 MHz	161	5805 MHz
153	5765 MHz	165	5825 MHz
157	5785 MHz		

2 channels are provided for 802.11n (HT40), 802.11ac (VHT40), 802.11ax (HE40):

Channel	Frequency	Channel	Frequency
151	5755 MHz	159	5795 MHz

1 channel is provided for 802.11ac (VHT80), 802.11ax (HE80):

Channel	Frequency
155	5775 MHz



### 3.4 Test Mode Applicability and Tested Channel Detail

Pre-Scan:	1. Pre-Scan has been conducted to determine the worst-case mode from all possible combinations between available modulations, data rates and antenna ports (if EUT with antenna diversity architecture).
-----------	--

Following channel(s) was (were) selected for the final test as listed below:

Test Item	Mode	Tested Channel	Modulation	Data Rate Parameter
RF Output Power	802.11a	36, 40, 48, 149, 157, 165	BPSK	6Mb/s
	802.11ax (HE20)	36, 40, 48, 149, 157, 165	BPSK	MCS0
	802.11ax (HE40)	38, 46, 151, 159	BPSK	MCS0
	802.11ax (HE80)	42, 155	BPSK	MCS0
AC Power Conducted Emissions	802.11ax (HE40)	151	BPSK	MCS0
Unwanted Emissions below 1 GHz	802.11ax (HE40)	151	BPSK	MCS0
Unwanted Emissions above 1 GHz	802.11ax (HE40)	151	BPSK	MCS0

### 3.5 Duty Cycle of Test Signal

**802.11a:** Duty cycle = 1.391 ms / 1.427 ms x 100% = 97.5%, duty factor = 10 \* log (1/Duty cycle) = 0.11 dB

**802.11ax (HE20):** Duty cycle = 0.538 ms / 0.573 ms x 100% = 93.9%, duty factor = 10 \* log (1/Duty cycle) = 0.27 dB

**802.11ax (HE40):** Duty cycle = 0.07 ms / 0.09 ms x 100% = 77.8%, duty factor = 10 \* log (1/Duty cycle) = 1.09 dB

**802.11ax (HE80):** Duty cycle = 0.043 ms / 0.061 ms x 100% = 70.5%, duty factor = 10 \* log (1/Duty cycle) = 1.52 dB

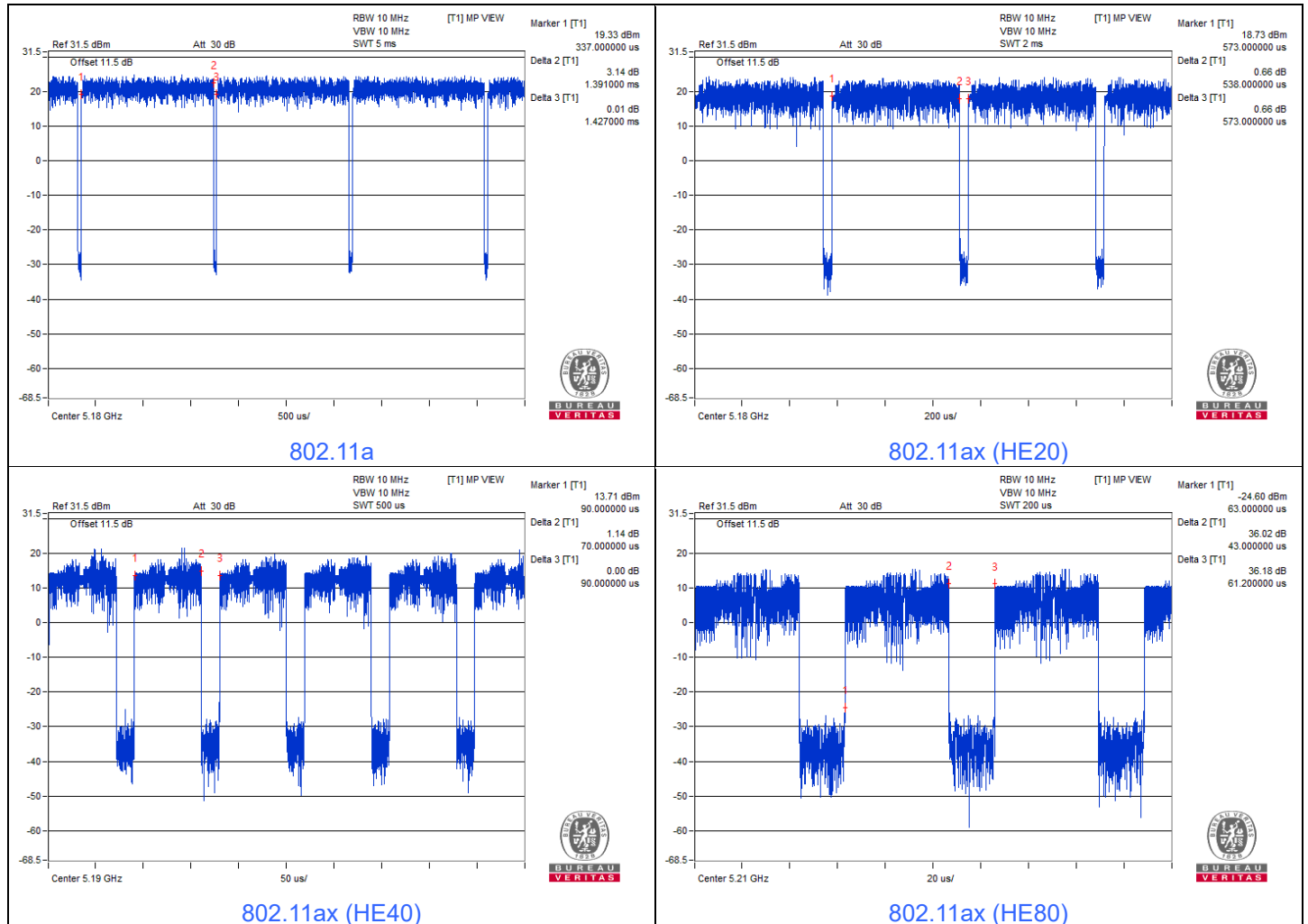

### 3.6 Test Program Used and Operation Descriptions

Controlling software (TeraTerm paste cmd.txt command) has been activated to set the EUT under transmission condition continuously at specific channel frequency.

### 3.7 Connection Diagram of EUT and Peripheral Devices

#### For Unwanted Emission test

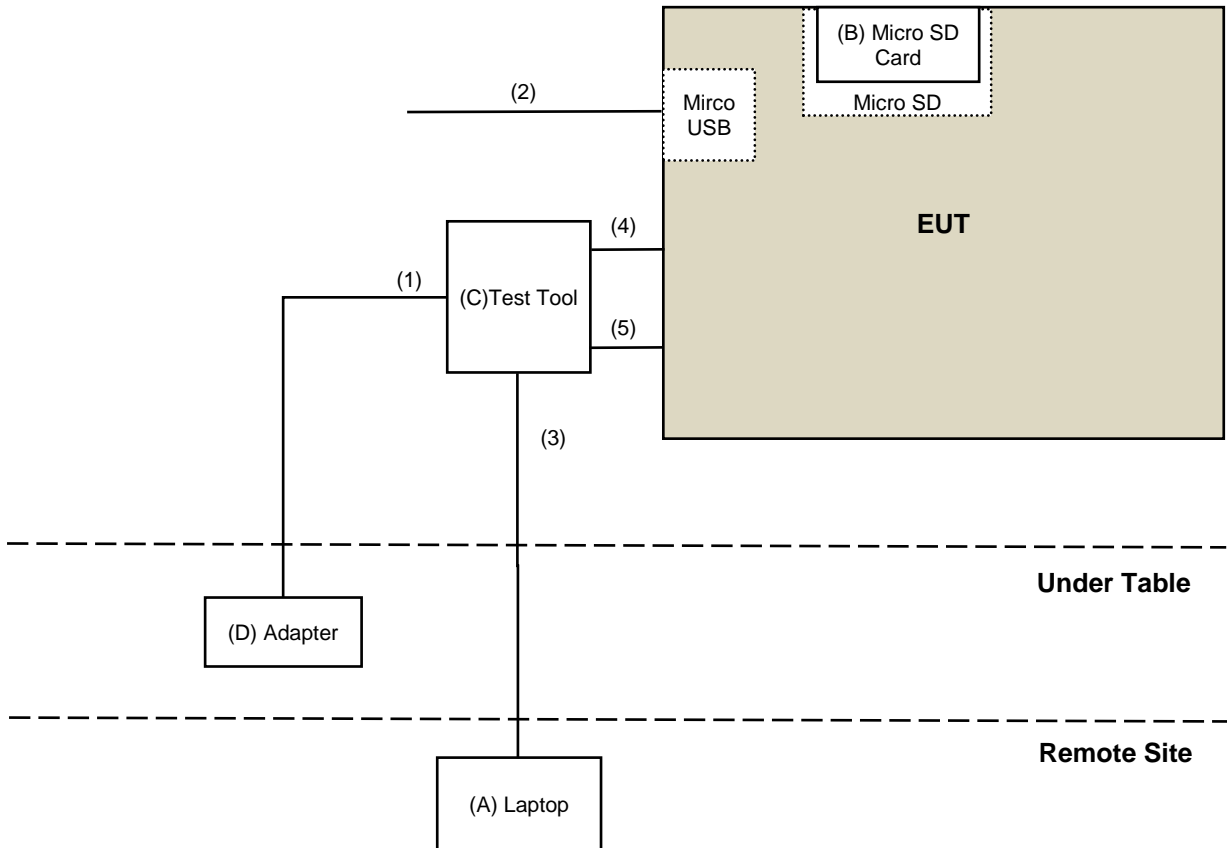

#### For AC Power Conducted Emission test

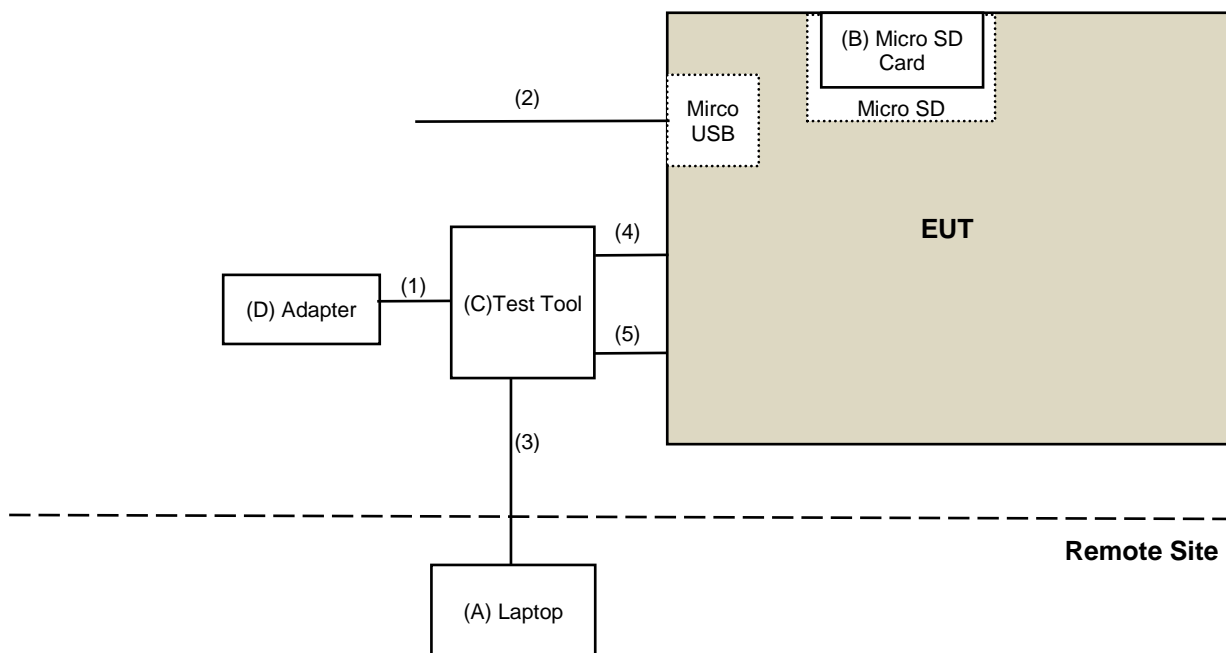

### 3.8 Configuration of Peripheral Devices and Cable Connections

ID	Product	Brand	Model No.	Serial No.	FCC ID	Remarks
A	Laptop	Lenovo	20U5S01X00 L14	PF-28LKK7	N/A	Provided by Lab
B	Micro SD Card	ADATA	N/A	N/A	N/A	Provided by Lab
C	Test Tool	Netgear	N/A	N/A	N/A	Supplied by applicant
D	Adapter	Netgear	ADS-40FPC-12 12030E	N/A	N/A	Supplied by applicant

ID	Cable Descriptions	Qty.	Length (m)	Shielding (Yes/No)	Cores (Qty.)	Remarks
1	DC Cable	1	2.5	No	0	Supplied by applicant (Brand: NETGEAR, Model: ADS-40FPC-12 12030E)
2	Micro USB Cable	1	1	No	0	Provided by Lab (Brand: Urgeen, Model: 10836)
3	LAN Cable	1	10	No	0	Provided by Lab (Brand: Tatung, Mode: E210587)
4	Console Cable	1	0.5	No	0	Supplied by applicant (Brand: NETGEAR, Model: NA)
5	Console Cable	1	0.5	No	0	Supplied by applicant (Brand: NETGEAR, Model: NA)

## 4 Test Instruments

The calibration interval of the all test instruments are 12 months and the calibrations are traceable to NML/ROC and NIST/USA.

### 4.1 RF Output Power

Description Manufacturer	Model No.	Serial No.	Calibrated Date	Calibrated Until
Fixed Attenuator Woken	MDCS18N-10	MDCS18N-10-01	2023/3/27	2024/3/26
Power Meter Anritsu	ML2495A	1529002	2022/6/22	2023/6/21
Pulse Power Sensor Anritsu	MA2411B	1726434	2022/6/22	2023/6/21

Notes:

1. The test was performed in Oven room 2.
2. Tested Date: 2023/6/7

### 4.2 AC Power Conducted Emissions

Description Manufacturer	Model No.	Serial No.	Calibrated Date	Calibrated Until
50 ohm terminal resistance	N/A	EMC-01	2022/9/27	2023/9/26
EMI Test Receiver R&S	ESCS 30	847124/029	2022/10/14	2023/10/13
Fixed Attenuator STI	STI02-2200-10	005	2022/8/24	2023/8/23
LISN R&S	ESH3-Z5	848773/004	2022/10/18	2023/10/17
RF Coaxial Cable JYEBO	5D-FB	COCCAB-001	2022/8/24	2023/8/23
Software BVADT	BVADT_Cond_V7.3.7.4	N/A	N/A	N/A

Notes:

1. The test was performed in Conduction 1
2. Tested Date: 2023/6/6

### 4.3 Unwanted Emissions below 1 GHz

Description Manufacturer	Model No.	Serial No.	Calibrated Date	Calibrated Until
Bi_Log Antenna Schwarzbeck	VULB 9168	9168-406	2022/10/21	2023/10/20
Boresight Antenna Tower & Turn Table Max-Full	MF-7802BS	MF780208530	N/A	N/A
Fixed Attenuator Mini-Circuits	UNAT-5+	PAD-ATT5-03	2022/12/28	2023/12/27
Loop Antenna Electro-Metrics	EM-6879	264	2023/2/21	2024/2/20
MXE EMI Receiver Keysight	N9038A	MY54450088	2022/7/11	2023/7/10
Preamplifier Agilent	8447D	2944A10636	2023/3/12	2024/3/11
Preamplifier EMCI	EMC330N	980701	2023/2/18	2024/2/17
PXA Signal Analyzer Keysight	N9030B	MY57142938	2023/4/6	2024/4/5
RF Coaxial Cable COMMATE/PEWC	8D	966-4-1	2023/2/18	2024/2/17
		966-4-2	2023/2/18	2024/2/17
		966-4-3	2023/2/18	2024/2/17
RF Coaxial Cable JYEBO	5D-FB	LOOPCAB-001	2022/12/19	2023/12/18
		LOOPCAB-002	2022/12/19	2023/12/18
Software	ADT_Radiated_V8.7.08	N/A	N/A	N/A

Notes:

1. The test was performed in 966 Chamber No. 4.
2. Tested Date: 2023/6/6

#### 4.4 Unwanted Emissions above 1 GHz

Description Manufacturer	Model No.	Serial No.	Calibrated Date	Calibrated Until
Boresight Antenna Tower & Turn Table Max-Full	MF-7802BS	MF780208530	N/A	N/A
Horn Antenna Schwarzbeck	BBHA 9120D	9120D-783	2022/11/13	2023/11/12
	BBHA 9170	9170-739	2022/11/13	2023/11/12
Preamplifier EMCI	EMC12630SE	980688	2022/10/4	2023/10/3
	EMC184045SE	980387	2022/12/28	2023/12/27
PXA Signal Analyzer Keysight	N9030B	MY57142938	2023/4/6	2024/4/5
RF Coaxial Cable EMCI	EMC-KM-KM-4000	200214	2023/2/20	2024/2/19
	EMC102-KM-KM-1200	160924	2022/12/28	2023/12/27
	EMC104-SM-SM-1200	160922	2022/12/15	2023/12/14
	EMC104-SM-SM-2000	180502	2023/3/27	2024/3/26
	EMC104-SM-SM-6000	210704	2022/11/4	2023/11/3
Software	ADT_Radiated_V8.7.08	N/A	N/A	N/A

Notes:

1. The test was performed in 966 Chamber No. 4.
2. Tested Date: 2023/5/30 ~ 2023/6/6

## 5 Limits of Test Items

### 5.1 RF Output Power

Operation Band	EUT Category	Limit
U-NII-1	Outdoor Access Point	1 Watt (30 dBm) (Max. e.i.r.p $\leq$ 125mW(21 dBm) at any elevation angle above 30 degrees as measured from the horizon)
	Fixed point-to-point Access Point	1 Watt (30 dBm)
	Indoor Access Point	1 Watt (30 dBm)
	Mobile and Portable client device	250mW (24 dBm)

Operation Band	Limit
U-NII-3	1 Watt (30 dBm)

Per KDB 662911 D01 Multiple Transmitter Output Method of conducted output power measurement on IEEE 802.11 devices,

Array Gain = 0 dB (i.e., no array gain) for  $N_{ANT} \leq 4$ ;

Array Gain = 0 dB (i.e., no array gain) for channel widths  $\geq 40$  MHz for any  $N_{ANT}$ ;

Array Gain =  $5 \log(N_{ANT}/N_{SS})$  dB or 3 dB, whichever is less, for 20-MHz channel widths with  $N_{ANT} \geq 5$ .

For power measurements on all other devices: Array Gain =  $10 \log(N_{ANT}/N_{SS})$  dB.

### 5.2 AC Power Conducted Emissions

Frequency (MHz)	Conducted Limit (dBuV)	
	Quasi-peak	Average
0.15 - 0.5	66 - 56	56 - 46
0.50 - 5.0	56	46
5.0 - 30.0	60	50

Notes:

1. The lower limit shall apply at the transition frequencies.
2. The limit decreases in line with the logarithm of the frequency in the range of 0.15 to 0.50 MHz.

### 5.3 Unwanted Emissions below 1 GHz

Radiated emissions which fall in the restricted bands must comply with the radiated emission limits specified as below table.

Frequencies (MHz)	Field Strength (microvolts/meter)	Measurement Distance (meters)
0.009 ~ 0.490	$2400/F(\text{kHz})$	300
0.490 ~ 1.705	$24000/F(\text{kHz})$	30
1.705 ~ 30.0	30	30
30 ~ 88	100	3
88 ~ 216	150	3
216 ~ 960	200	3
Above 960	500	3

Notes:

1. The lower limit shall apply at the transition frequencies.
2. Emission level (dBuV/m) =  $20 \log$  Emission level (uV/m).



## 5.4 Unwanted Emissions above 1 GHz

Radiated emissions which fall in the restricted bands must comply with the radiated emission limits specified as below table.

Frequencies (MHz)	Field Strength (microvolts/meter)	Measurement Distance (meters)
Above 960	500	3

Notes:

1. The lower limit shall apply at the transition frequencies.
2. Emission level (dBuV/m) = 20 log Emission level (uV/m).
3. For frequencies above 1000 MHz, the field strength limits are based on average detector, however, the peak field strength of any emission shall not exceed the maximum permitted average limits, specified above by more than 20 dB under any condition of modulation.

Limits of unwanted emission out of the restricted bands

Applicable To	Limit	
789033 D02 General UNII Test Procedure New Rules v02r01	Field Strength at 3 m	
	PK: 74 (dBμV/m)	AV: 54 (dBμV/m)

For transmitters operating in the 5.15-5.25 GHz band:

Applicable To	EIRP Limit	Equivalent Field Strength at 3 m
15.407(b)(1)	PK: -27 (dBm/MHz)	PK: 68.2 (dBμV/m)

For transmitters operating in the 5.725-5.850 GHz band:

Applicable To	EIRP Limit	Equivalent Field Strength at 3 m
15.407(b)(4)(i)	PK: -27 (dBm/MHz) <sup>*1</sup> PK: 10 (dBm/MHz) <sup>*2</sup> PK: 15.6 (dBm/MHz) <sup>*3</sup> PK: 27 (dBm/MHz) <sup>*4</sup>	PK: 68.2 (dBμV/m) <sup>*1</sup> PK: 105.2 (dBμV/m) <sup>*2</sup> PK: 110.8 (dBμV/m) <sup>*3</sup> PK: 122.2 (dBμV/m) <sup>*4</sup>

<sup>\*1</sup> beyond 75 MHz or more above of the band edge.

<sup>\*2</sup> below the band edge increasing linearly to 10 dBm/MHz at 25 MHz above.

<sup>\*3</sup> below the band edge increasing linearly to a level of 15.6 dBm/MHz at 5 MHz above.

<sup>\*4</sup> from 5 MHz above or below the band edge increasing linearly to a level of 27 dBm/MHz at the band edge.

Note: The following formula is used to convert the equipment isotropic radiated power (eirp) to field strength:

$$E = \frac{1000000\sqrt{30P}}{3} \mu\text{V/m, where P is the eirp (Watts).}$$

## 6 Test Arrangements

### 6.1 RF Output Power

#### 6.1.1 Test Setup

Conducted Measurement Method

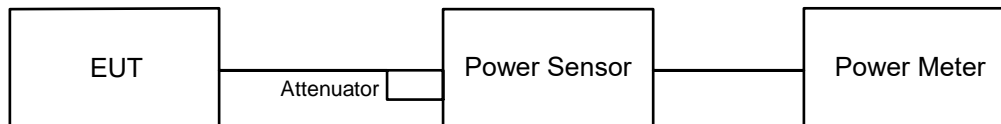

#### 6.1.2 Test Procedure

Conducted Measurement Method

Method PM is used to perform output power measurement, trigger and gating function of wide band power meter is enabled to measure max output power of TX on burst and set the detector to average. Duty factor is not added to measured value.

### 6.2 AC Power Conducted Emissions

#### 6.2.1 Test Setup

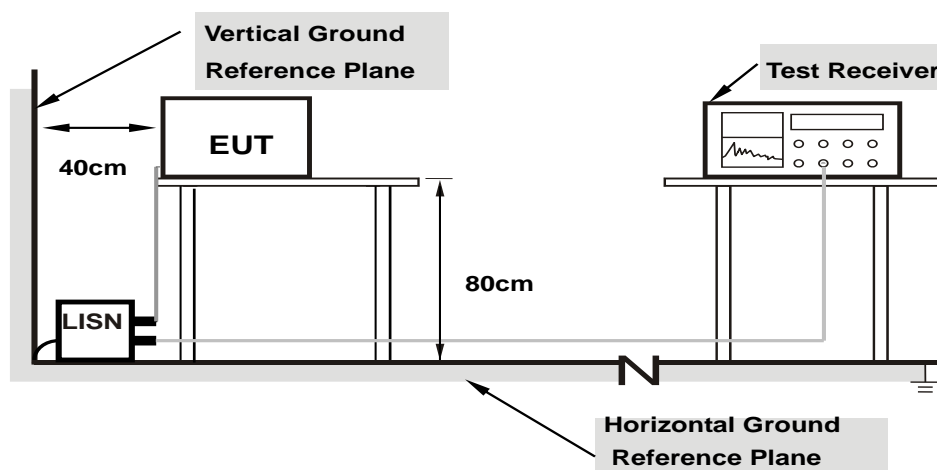

**Note: 1.Support units were connected to second LISN.**

For the actual test configuration, please refer to the attached file (Test Setup Photo).

#### 6.2.2 Test Procedure

- The EUT was placed on a 0.8 meter to the top of table and placed 0.4 meters from the conducting wall of the shielded room with EUT being connected to the power mains through a line impedance stabilization network (LISN). Other support units were connected to the power mains through another LISN. The two LISNs provide 50 ohm/ 50 uH of coupling impedance for the measuring instrument.
- Both lines of the power mains connected to the EUT were checked for maximum conducted interference.
- The frequency range from 150 kHz to 30 MHz was searched. Emission levels under (Limit – 20 dB) was not recorded.

Note: The resolution bandwidth and video bandwidth of test receiver is 9 kHz for quasi-peak detection (QP) and average detection (AV) at frequency 0.15 MHz-30 MHz.

### 6.3 Unwanted Emissions below 1 GHz

#### 6.3.1 Test Setup

##### For Radiated emission below 30 MHz

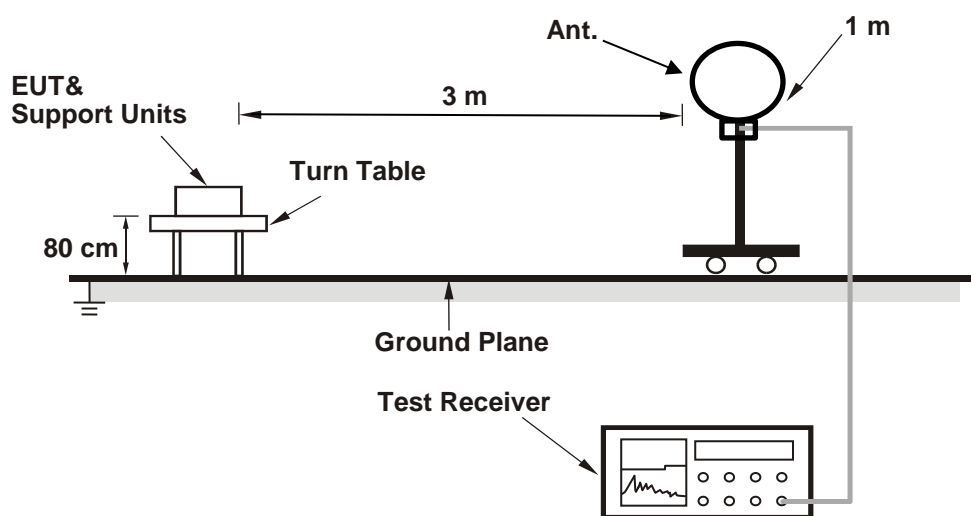

##### For Radiated emission above 30 MHz

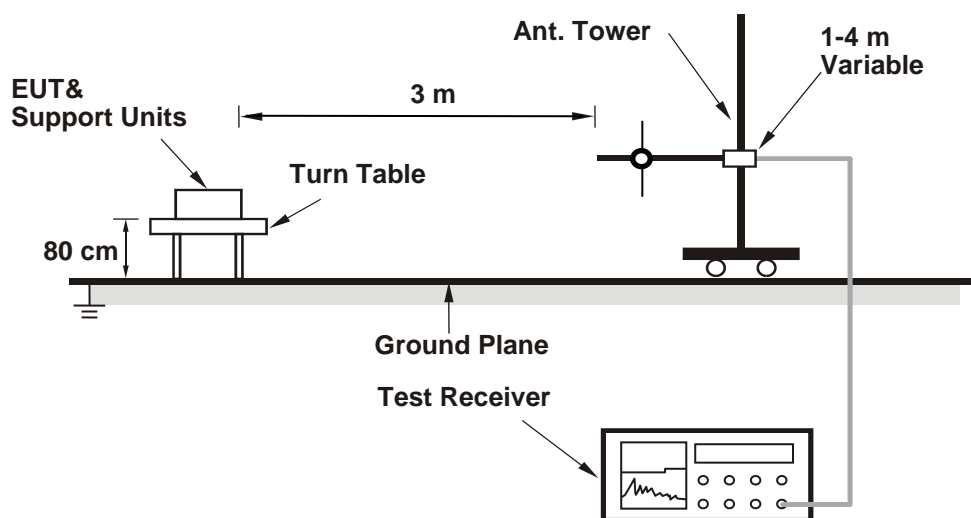

For the actual test configuration, please refer to the attached file (Test Setup Photo).

### 6.3.2 Test Procedure

#### For Radiated emission below 30 MHz

- a. The EUT was placed on the top of a rotating table 0.8 meters above the ground at 3 meter chamber room for test. The table was rotated 360 degrees to determine the position of the highest radiation.
- b. The EUT was set 3 meters away from the interference-receiving antenna, which was mounted on the top of a variable-height antenna tower.
- c. Parallel, perpendicular, and ground-parallel orientations of the antenna are set to make the measurement.
- d. For each suspected emission, the EUT was arranged to its worst case and the rotatable table was turned from 0 degrees to 360 degrees to find the maximum reading.
- e. The test-receiver system was set to Quasi-Peak Detect Function and Specified Bandwidth with Maximum Hold Mode, except for the frequency band (9 kHz to 90 kHz and 110 kHz to 490 kHz) set to average detect function and peak detect function.

#### Notes:

1. The resolution bandwidth and video bandwidth of test receiver/spectrum analyzer is 200 Hz at frequency below 150 kHz.
2. The resolution bandwidth and video bandwidth of test receiver/spectrum analyzer is 9 kHz or 10 kHz at frequency (150 kHz to 30 MHz).
3. All modes of operation were investigated and the worst-case emissions are reported.

#### For Radiated emission above 30 MHz

- a. The EUT was placed on the top of a rotating table 0.8 meters above the ground at 3 meter chamber room for test. The table was rotated 360 degrees to determine the position of the highest radiation.
- b. The EUT was set 3 meters away from the interference-receiving antenna, which was mounted on the top of a variable-height antenna tower.
- c. The height of antenna is varied from one meter to four meters above the ground to determine the maximum value of the field strength. Both horizontal and vertical polarizations of the antenna are set to make the measurement.
- d. For each suspected emission, the EUT was arranged to its worst case and then the antenna was tuned to heights from 1 meter to 4 meters and the rotatable table was turned from 0 degrees to 360 degrees to find the maximum reading.
- e. The test-receiver system was set to Quasi-peak(QP) detect function, Average(AV) detect function, Peak(PK) detect function and specified bandwidth with maximum hold mode when the test frequency is below 1 GHz.

#### Notes:

1. The resolution bandwidth and video bandwidth of test receiver/spectrum analyzer is 120 kHz for Quasi-peak detection (QP), Average detection (AV), Peak detection (PK) at frequency (30MHz to 1 GHz).
2. All modes of operation were investigated and the worst-case emissions are reported.

## 6.4 Unwanted Emissions above 1 GHz

### 6.4.1 Test Setup

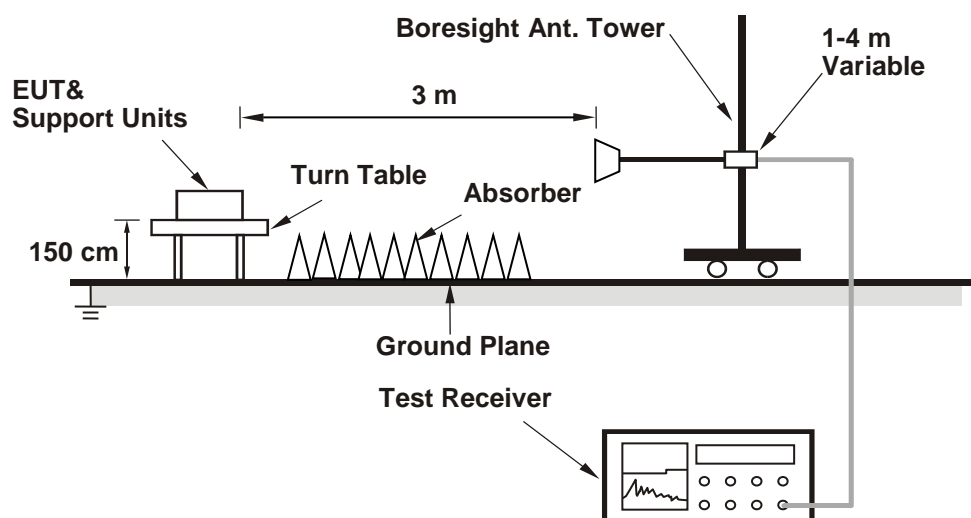

For the actual test configuration, please refer to the attached file (Test Setup Photo).

### 6.4.2 Test Procedure

- The EUT was placed on the top of a rotating table 1.5 meters above the ground at 3 meter chamber room for test. The table was rotated 360 degrees to determine the position of the highest radiation.
- The EUT was set 3 meters away from the interference-receiving antenna, which was mounted on the top of a variable-height antenna tower.
- The height of antenna is varied from one meter to four meters above the ground to determine the maximum value of the field strength. Both horizontal and vertical polarizations of the antenna are set to make the measurement.
- For each suspected emission, the EUT was arranged to its worst case and then the antenna was tuned to heights from 1 meter to 4 meters and the rotatable table was turned from 0 degrees to 360 degrees to find the maximum reading.
- The test-receiver system was set to peak and average detects function and specified bandwidth with maximum hold mode when the test frequency is above 1 GHz. If the peak reading value also meets average limit, measurement with the average detector is unnecessary.

#### Notes:

- The resolution bandwidth of test receiver/spectrum analyzer is 1 MHz and the video bandwidth is 3 MHz for Peak detection (PK) and Average detection (AV) at frequency above 1 GHz.
- For fundamental and harmonic signal measurement, the resolution bandwidth of test receiver/spectrum analyzer is 1 MHz and the video bandwidth is  $\geq 1/T$  (Duty cycle  $< 98\%$ ) or 10 Hz (Duty cycle  $\geq 98\%$ ) for Average detection (AV) at frequency above 1 GHz.
- All modes of operation were investigated and the worst-case emissions are reported.

## 7 Test Results of Test Item

### 7.1 RF Output Power

Input Power:	12 Vdc	Environmental Conditions:	25°C, 60% RH	Tested By:	John Peng
--------------	--------	---------------------------	--------------	------------	-----------

#### 802.11a

Chan.	Chan. Freq. (MHz)	Average Power (dBm)		Total Power (mW)	Total Power (dBm)	Power Limit (dBm)	Test Result
		Chain 0	Chain 1				
36	5180	18.52	18.86	148.034	21.70	24	Pass
40	5200	20.40	20.85	231.266	23.64	24	Pass
48	5240	20.64	20.59	230.429	23.63	24	Pass
149	5745	24.20	24.65	554.77	27.44	30	Pass
157	5785	24.42	24.12	534.92	27.28	30	Pass
165	5825	23.99	24.31	520.385	27.16	30	Pass

Notes:

1. Directional gain is the maximum gain of antennas.
2. For U-NII-1, the maximum gain is 2.03 dBi < 6 dBi, so the output power limit shall not be reduced.
3. For U-NII-3, the maximum gain is 2.33 dBi < 6 dBi, so the output power limit shall not be reduced.

#### 802.11ax (HE20)

Chan.	Chan. Freq. (MHz)	Average Power (dBm)		Total Power (mW)	Total Power (dBm)	Power Limit (dBm)	Test Result
		Chain 0	Chain 1				
36	5180	17.77	18.54	131.291	21.18	24	Pass
40	5200	20.51	20.95	236.912	23.75	24	Pass
48	5240	20.85	20.90	244.645	23.89	24	Pass
149	5745	23.67	23.91	478.846	26.80	30	Pass
157	5785	23.65	23.96	480.625	26.82	30	Pass
165	5825	23.57	23.92	474.114	26.76	30	Pass

Notes:

1. Directional gain is the maximum gain of antennas.
2. For U-NII-1, the maximum gain is 2.03 dBi < 6 dBi, so the output power limit shall not be reduced.
3. For U-NII-3, the maximum gain is 2.33 dBi < 6 dBi, so the output power limit shall not be reduced.

### 802.11ax (HE40)

Chan.	Chan. Freq. (MHz)	Average Power (dBm)		Total Power (mW)	Total Power (dBm)	Power Limit (dBm)	Test Result
		Chain 0	Chain 1				
38	5190	16.78	17.34	101.843	20.08	24	Pass
46	5230	18.35	19.06	148.929	21.73	24	Pass
151	5755	24.04	24.98	568.288	27.55	30	Pass
159	5795	24.06	24.93	565.855	27.53	30	Pass

Notes:

1. Directional gain is the maximum gain of antennas.
2. For U-NII-1, the maximum gain is 2.03 dBi < 6 dBi, so the output power limit shall not be reduced.
3. For U-NII-3, the maximum gain is 2.33 dBi < 6 dBi, so the output power limit shall not be reduced.

### 802.11ax (HE80)

Chan.	Chan. Freq. (MHz)	Average Power (dBm)		Total Power (mW)	Total Power (dBm)	Power Limit (dBm)	Test Result
		Chain 0	Chain 1				
42	5210	16.32	16.85	91.272	19.60	24	Pass
155	5775	21.68	22.09	309.039	24.90	30	Pass

Notes:

1. Directional gain is the maximum gain of antennas.
2. For U-NII-1, the maximum gain is 2.03 dBi < 6 dBi, so the output power limit shall not be reduced.
3. For U-NII-3, the maximum gain is 2.33 dBi < 6 dBi, so the output power limit shall not be reduced.

## 7.2 AC Power Conducted Emissions

RF Mode	802.11ax (HE40)	Channel	CH 151 : 5755 MHz
Frequency Range	150kHz ~ 30MHz	Detector Function & Resolution Bandwidth	Quasi-Peak (QP) / Average (AV), 9 kHz
Input Power (System)	120 Vac, 60 Hz	Environmental Conditions	25°C, 66% RH
Tested By	Tom Yang		

Phase Of Power : Line (L)										
No	Frequency (MHz)	Correction Factor (dB)	Reading Value (dBuV)		Emission Level (dBuV)		Limit (dBuV)		Margin (dB)	
			Q.P.	AV.	Q.P.	AV.	Q.P.	AV.	Q.P.	AV.
1	0.15947	9.98	31.32	16.45	41.30	26.43	65.49	55.49	-24.19	-29.06
<b>2</b>	<b>0.36159</b>	<b>9.99</b>	<b>35.68</b>	<b>32.14</b>	<b>45.67</b>	<b>42.13</b>	<b>58.69</b>	<b>48.69</b>	<b>-13.02</b>	<b>-6.56</b>
3	0.54371	10.00	21.72	17.53	31.72	27.53	56.00	46.00	-24.28	-18.47
4	0.96717	10.03	21.15	16.77	31.18	26.80	56.00	46.00	-24.82	-19.20
5	1.75951	10.08	16.35	12.96	26.43	23.04	56.00	46.00	-29.57	-22.96
6	2.99117	10.18	13.70	9.83	23.88	20.01	56.00	46.00	-32.12	-25.99

### Remarks:

1. Q.P. and AV. are abbreviations of quasi-peak and average individually.
2. The emission levels of other frequencies were very low against the limit.
3. Margin value = Emission level – Limit value
4. Correction factor = Insertion loss + Cable loss
5. Emission Level = Correction Factor + Reading Value

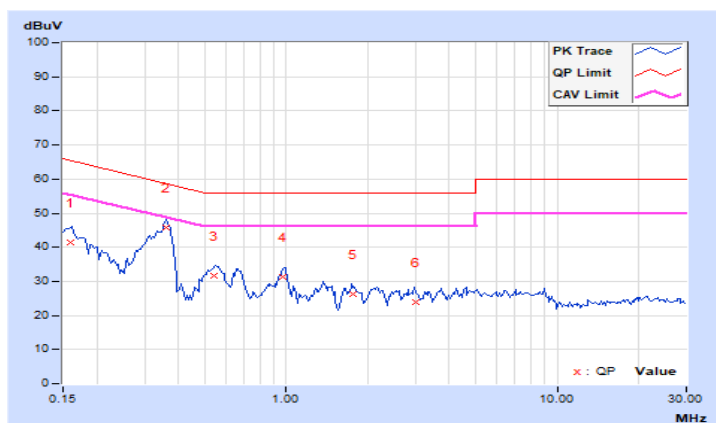



<b>RF Mode</b>	802.11ax (HE40)	<b>Channel</b>	CH 151 : 5755 MHz
<b>Frequency Range</b>	150kHz ~ 30MHz	<b>Detector Function &amp; Resolution Bandwidth</b>	Quasi-Peak (QP) / Average (AV), 9 kHz
<b>Input Power (System)</b>	120 Vac, 60 Hz	<b>Environmental Conditions</b>	25°C, 66% RH
<b>Tested By</b>	Tom Yang		

Phase Of Power : Neutral (N)										
No	Frequency (MHz)	Correction Factor (dB)	Reading Value (dBuV)		Emission Level (dBuV)		Limit (dBuV)		Margin (dB)	
			Q.P.	AV.	Q.P.	AV.	Q.P.	AV.	Q.P.	AV.
1	0.15531	10.02	32.48	18.16	42.50	28.18	65.71	55.71	-23.21	-27.53
2	0.17992	10.03	29.45	16.43	39.48	26.46	64.49	54.49	-25.01	-28.03
3	0.35982	10.04	33.37	29.85	43.41	39.89	58.73	48.73	-15.32	-8.84
4	0.54717	10.05	20.53	16.46	30.58	26.51	56.00	46.00	-25.42	-19.49
5	0.96015	10.08	21.29	17.69	31.37	27.77	56.00	46.00	-24.63	-18.23
6	2.15317	10.16	16.38	12.84	26.54	23.00	56.00	46.00	-29.46	-23.00

**Remarks:**

1. Q.P. and AV. are abbreviations of quasi-peak and average individually.
2. The emission levels of other frequencies were very low against the limit.
3. Margin value = Emission level – Limit value
4. Correction factor = Insertion loss + Cable loss
5. Emission Level = Correction Factor + Reading Value

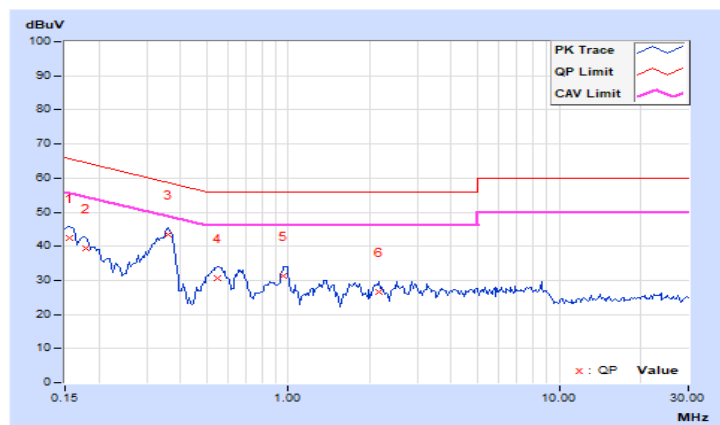

### 7.3 Unwanted Emissions below 1 GHz

RF Mode	802.11ax (HE40)	Channel	CH 151 : 5755 MHz
Frequency Range	30 MHz ~ 1 GHz	Detector Function & Bandwidth	(QP) RB = 120kHz
Input Power (System)	120 Vac, 60 Hz	Environmental Conditions	25°C, 66% RH
Tested By	Tom Yang		

#### Antenna Polarity & Test Distance : Horizontal at 3 m

No	Frequency (MHz)	Emission Level (dBuV/m)	Limit (dBuV/m)	Margin (dB)	Antenna Height (m)	Table Angle (Degree)	Raw Value (dBuV)	Correction Factor (dB/m)
1	87.11	27.7 QP	40.0	-12.3	2.00 H	246	46.6	-18.9
2	250.02	35.7 QP	46.0	-10.3	1.00 H	178	49.9	-14.2
3	375.09	37.1 QP	46.0	-8.9	1.50 H	233	47.6	-10.5
4	499.95	34.3 QP	46.0	-11.7	1.00 H	176	41.9	-7.6
5	625.03	40.4 QP	46.0	-5.6	1.50 H	215	44.9	-4.5
6	749.95	37.7 QP	46.0	-8.3	2.00 H	317	40.3	-2.6

#### Remarks:

1. Emission Level(dBuV/m) = Raw Value(dBuV) + Correction Factor(dB/m)
2. Correction Factor(dB/m) = Antenna Factor(dB/m) + Cable Factor(dB) – Pre-Amplifier Factor(dB)
3. Margin value = Emission Level – Limit value
4. The other emission levels were very low against the limit of frequency range 30 MHz ~ 1 GHz.
5. The emission levels were very low against the limit of frequency range 9 kHz ~ 30 MHz: the amplitude of spurious emissions attenuated more than 20 dB below the permissible value to be report.

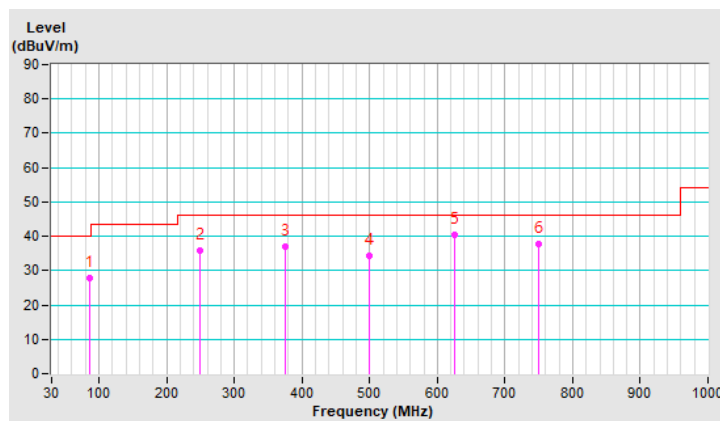

<b>RF Mode</b>	802.11ax (HE40)	<b>Channel</b>	CH 151 : 5755 MHz
<b>Frequency Range</b>	30 MHz ~ 1 GHz	<b>Detector Function &amp; Bandwidth</b>	(QP) RB = 120kHz
<b>Input Power (System)</b>	120 Vac, 60 Hz	<b>Environmental Conditions</b>	25°C, 66% RH
<b>Tested By</b>	Tom Yang		

Antenna Polarity & Test Distance : Vertical at 3 m								
No	Frequency (MHz)	Emission Level (dBuV/m)	Limit (dBuV/m)	Margin (dB)	Antenna Height (m)	Table Angle (Degree)	Raw Value (dBuV)	Correction Factor (dB/m)
1	46.00	35.9 QP	40.0	-4.1	1.50 V	125	49.0	-13.1
2	83.49	28.8 QP	40.0	-11.2	2.00 V	282	47.4	-18.6
3	250.01	25.4 QP	46.0	-20.6	1.00 V	120	39.6	-14.2
4	374.97	39.2 QP	46.0	-6.8	1.50 V	248	49.7	-10.5
5	625.01	36.8 QP	46.0	-9.2	1.00 V	330	41.3	-4.5
6	874.94	40.9 QP	46.0	-5.1	1.50 V	173	42.0	-1.1

**Remarks:**

1. Emission Level(dBuV/m) = Raw Value(dBuV) + Correction Factor(dB/m)
2. Correction Factor(dB/m) = Antenna Factor(dB/m) + Cable Factor(dB) – Pre-Amplifier Factor(dB)
3. Margin value = Emission Level – Limit value
4. The other emission levels were very low against the limit of frequency range 30 MHz ~ 1 GHz.
5. The emission levels were very low against the limit of frequency range 9 kHz ~ 30 MHz: the amplitude of spurious emissions attenuated more than 20 dB below the permissible value to be report.

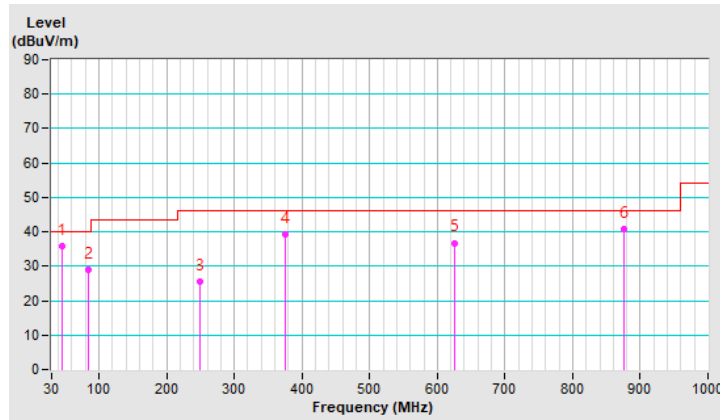

#### 7.4 Unwanted Emissions above 1 GHz

<b>RF Mode</b>	802.11ax (HE40)	<b>Channel</b>	CH 151 : 5755 MHz
<b>Frequency Range</b>	1 GHz ~ 40 GHz	<b>Detector Function &amp; Bandwidth</b>	(PK) RB = 1 MHz, VB = 3 MHz (AV) RB = 1 MHz, VB = 20 kHz
<b>Input Power (System)</b>	120 Vac, 60 Hz	<b>Environmental Conditions</b>	27°C, 67% RH
<b>Tested By</b>	Tom Yang		

Antenna Polarity & Test Distance : Horizontal at 3 m								
No	Frequency (MHz)	Emission Level (dBuV/m)	Limit (dBuV/m)	Margin (dB)	Antenna Height (m)	Table Angle (Degree)	Raw Value (dBuV)	Correction Factor (dB/m)
1	#5649.17	59.9 PK	68.2	-8.3	1.32 H	14	54.0	5.9
2	*5755.00	106.5 PK			1.32 H	14	100.7	5.8
3	*5755.00	98.3 AV			1.32 H	14	92.5	5.8
4	#5928.67	55.0 PK	68.2	-13.2	1.32 H	14	48.7	6.3
5	11510.00	59.3 PK	74.0	-14.7	1.51 H	128	42.4	16.9
6	11510.00	49.9 AV	54.0	-4.1	1.51 H	128	33.0	16.9
7	#17265.00	51.3 PK	68.2	-16.9	1.50 H	127	30.2	21.1

#### Remarks:

1. Emission Level(dBuV/m) = Raw Value(dBuV) + Correction Factor(dB/m)
2. Correction Factor(dB/m) = Antenna Factor(dB/m) + Cable Factor(dB) – Pre-Amplifier Factor(dB)
3. Margin value = Emission Level – Limit value
4. The other emission levels were very low against the limit.
5. " \* " : Fundamental frequency, the limit was restricted at the RF Output Power.
6. " # " : The radiated frequency is out of the restricted band.

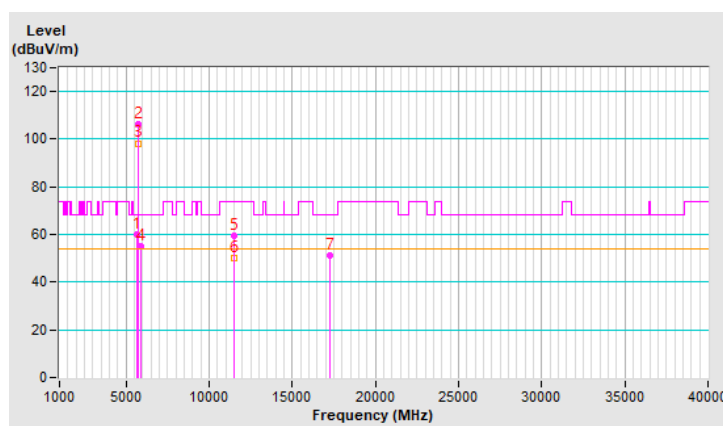

<b>RF Mode</b>	802.11ax (HE40)	<b>Channel</b>	CH 151 : 5755 MHz
<b>Frequency Range</b>	1 GHz ~ 40 GHz	<b>Detector Function &amp; Bandwidth</b>	(PK) RB = 1 MHz, VB = 3 MHz (AV) RB = 1 MHz, VB = 20 kHz
<b>Input Power (System)</b>	120 Vac, 60 Hz	<b>Environmental Conditions</b>	27°C, 67% RH
<b>Tested By</b>	Tom Yang		

Antenna Polarity & Test Distance : Vertical at 3 m								
No	Frequency (MHz)	Emission Level (dBuV/m)	Limit (dBuV/m)	Margin (dB)	Antenna Height (m)	Table Angle (Degree)	Raw Value (dBuV)	Correction Factor (dB/m)
1	#5650.00	67.9 PK	68.2	-0.3	1.56 V	54	62.0	5.9
2	*5755.00	115.2 PK			1.56 V	54	109.4	5.8
3	*5755.00	109.1 AV			1.56 V	54	103.3	5.8
4	#5961.93	63.8 PK	68.2	-4.4	1.56 V	54	57.5	6.3
5	11510.00	54.8 PK	74.0	-19.2	2.09 V	172	37.9	16.9
6	11510.00	46.5 AV	54.0	-7.5	2.09 V	172	29.6	16.9
7	#17265.00	50.2 PK	68.2	-18.0	1.55 V	155	29.1	21.1

**Remarks:**

1. Emission Level(dBuV/m) = Raw Value(dBuV) + Correction Factor(dB/m)
2. Correction Factor(dB/m) = Antenna Factor(dB/m) + Cable Factor(dB) – Pre-Amplifier Factor(dB)
3. Margin value = Emission Level – Limit value
4. The other emission levels were very low against the limit.
5. " \* " : Fundamental frequency, the limit was restricted at the RF Output Power.
6. " # " : The radiated frequency is out of the restricted band.

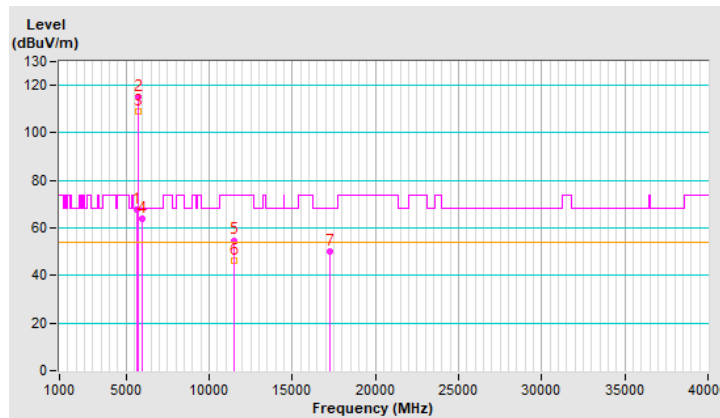

### Plot of Band Edge

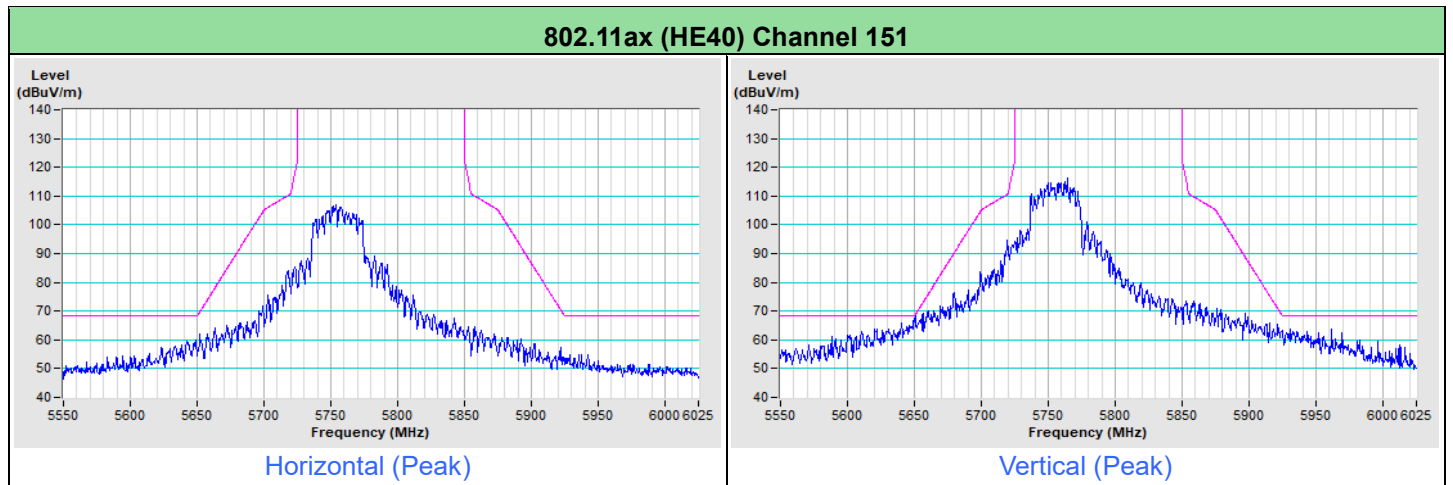

## 8 Pictures of Test Arrangements

Please refer to the attached file (Test Setup Photo)

## 9 Information of the Testing Laboratories

We, Bureau Veritas Consumer Products Services (H.K.) Ltd., Taoyuan Branch, were founded in 1988 to provide our best service in EMC, Radio, Telecom and Safety consultation. Our laboratories are FCC recognized accredited test firms and accredited according to ISO/IEC 17025.

If you have any comments, please feel free to contact us at the following:

**Lin Kou EMC/RF Lab**

Tel: 886-2-26052180

Fax: 886-2-26051924

**Hsin Chu EMC/RF/Telecom Lab**

Tel: 886-3-6668565

Fax: 886-3-6668323

**Hwa Ya EMC/RF/Safety Lab**

Tel: 886-3-3183232

Fax: 886-3-3270892

**Email:** [service.adt@bureauveritas.com](mailto:service.adt@bureauveritas.com)

**Web Site:** <http://ee.bureauveritas.com.tw>

The address and road map of all our labs can be found in our web site also.

--- END ---