

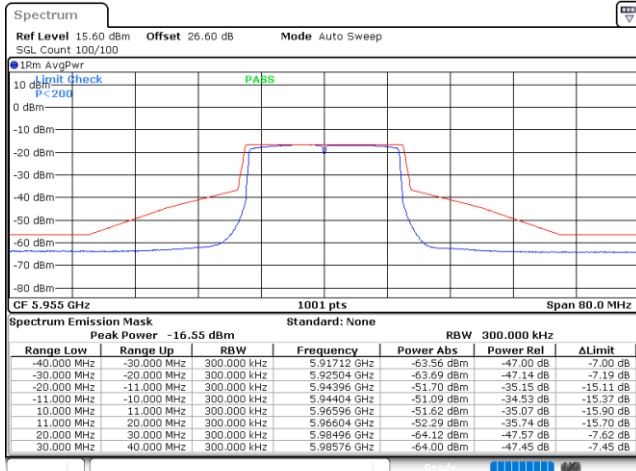

EUT Mode : 802.11ax HE20

Plot on Channel 5955MHz



Date: 28.NOV.2021 00:43:50

Plot on Channel 6175MHz

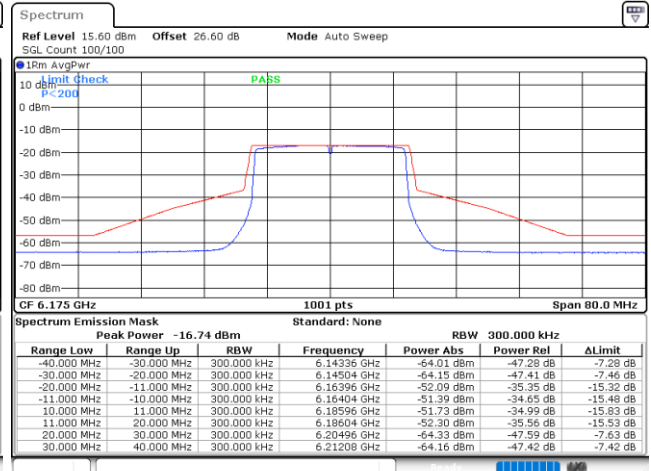

Date: 28.NOV.2021 00:47:47

Plot on Channel 6415MHz

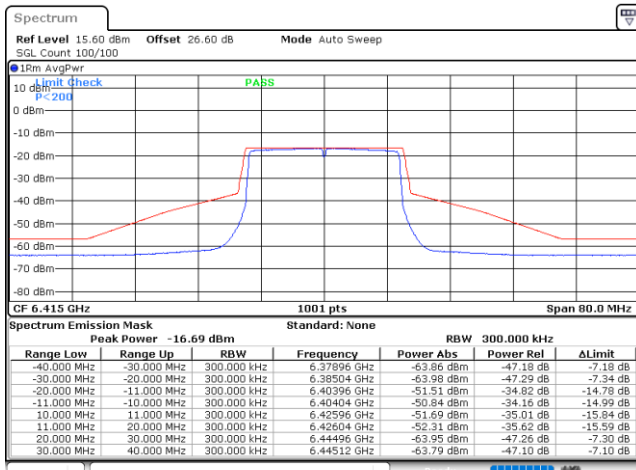

Date: 28.NOV.2021 00:55:35

Plot on Channel 6435MHz

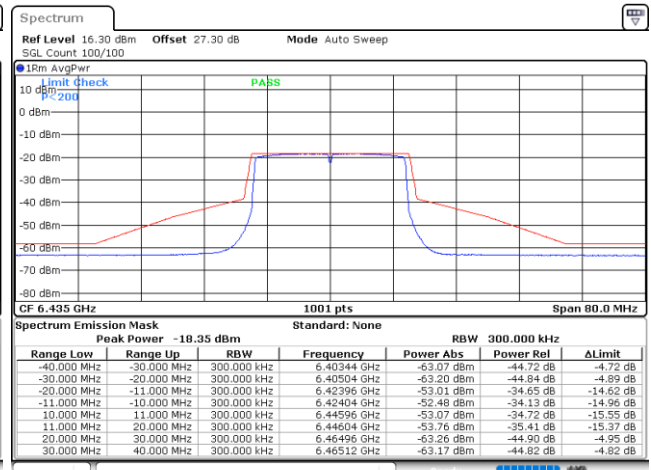

Date: 28.NOV.2021 01:00:04



Plot on Channel 6475MHz

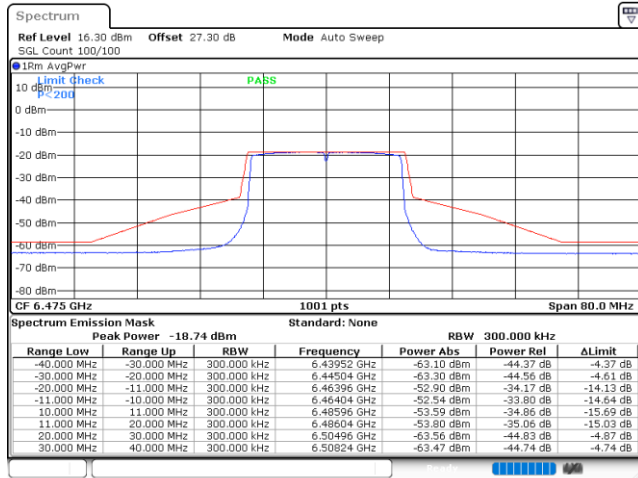

Date: 28.NOV.2021 01:08:54

Plot on Channel 6515MHz

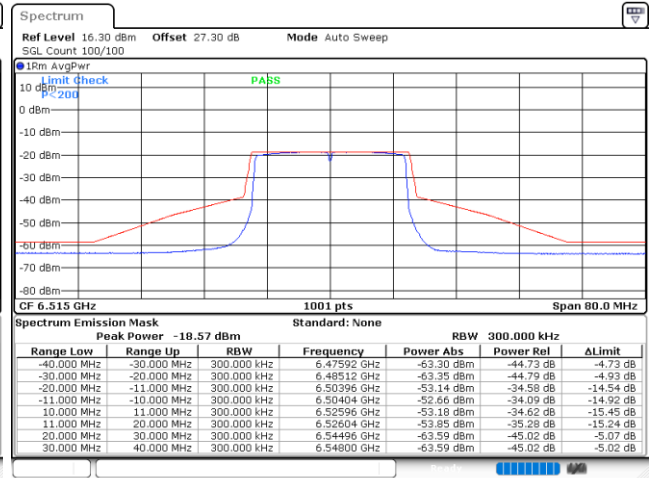

Date: 28.NOV.2021 01:13:44

Plot on Channel 6535MHz

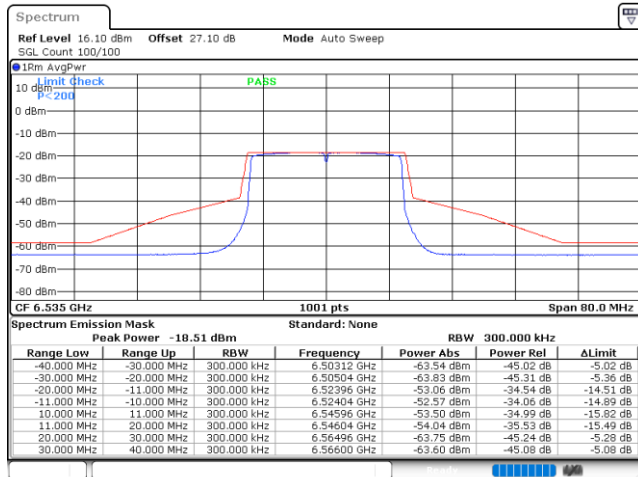

Date: 28.NOV.2021 01:17:53

Plot on Channel 6695MHz

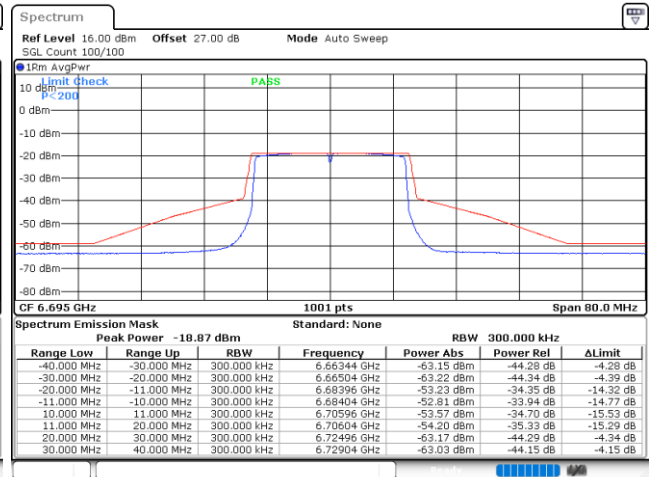

Date: 28.NOV.2021 01:23:27



Plot on Channel 6855MHz

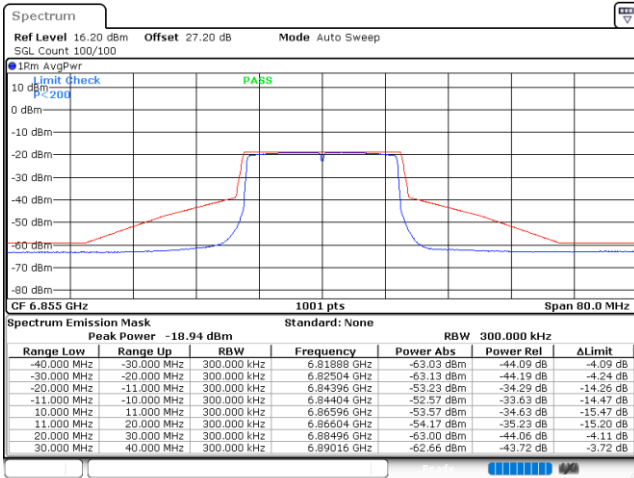

Date: 28.NOV.2021 01:29:18

Plot on Channel 6875MHz

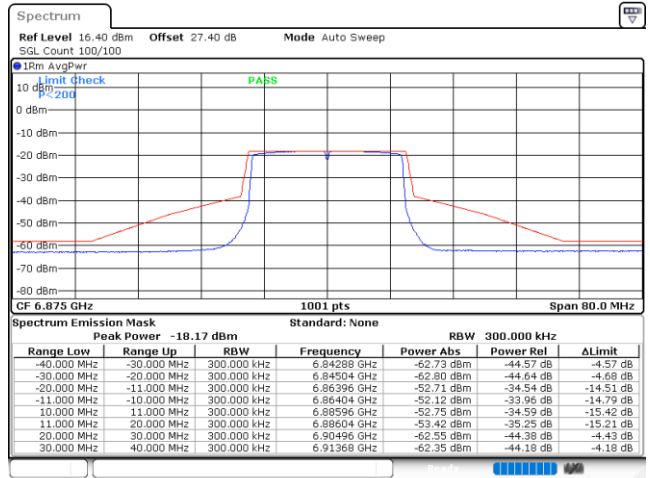

Date: 28.NOV.2021 01:36:36

Plot on Channel 6995MHz

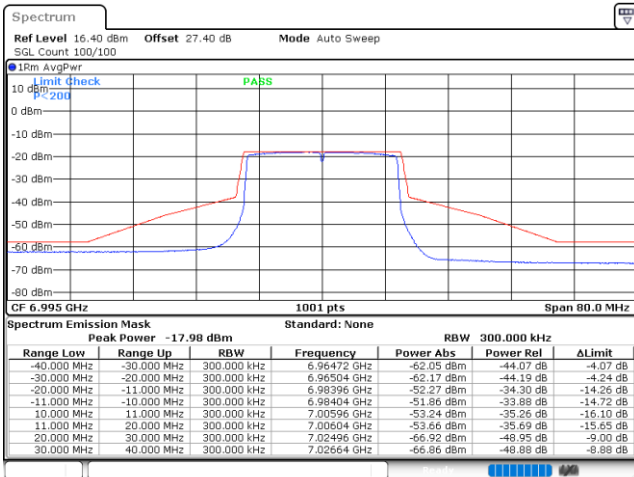

Date: 28.NOV.2021 01:40:28

Plot on Channel 7115MHz

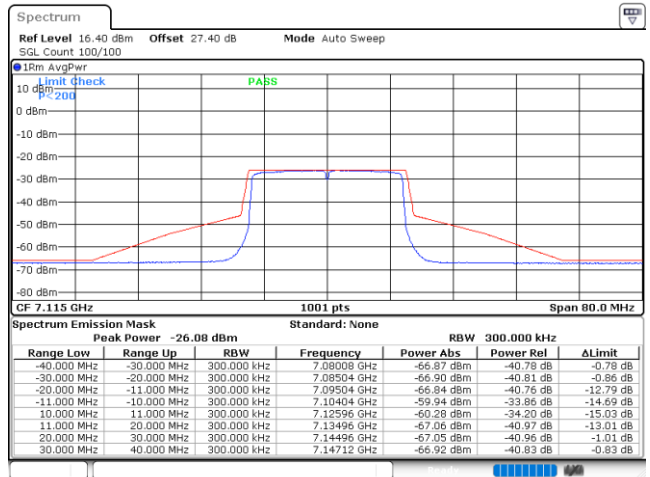

Date: 22.DEC.2021 05:48:37



EUT Mode : 802.11ax HE40

Plot on Channel 5965MHz

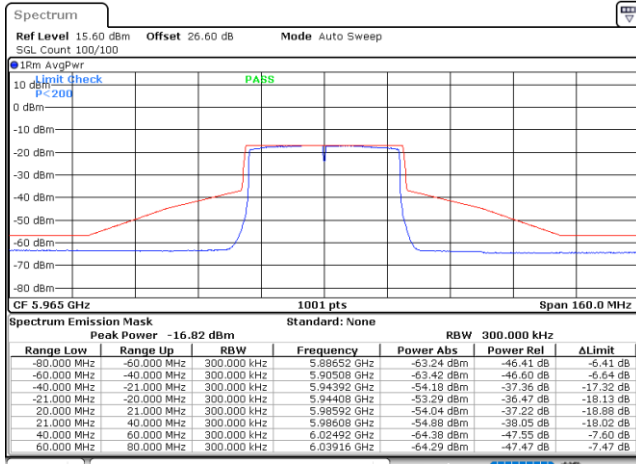

Date: 27.NOV.2021 22:55:50

Plot on Channel 6165MHz

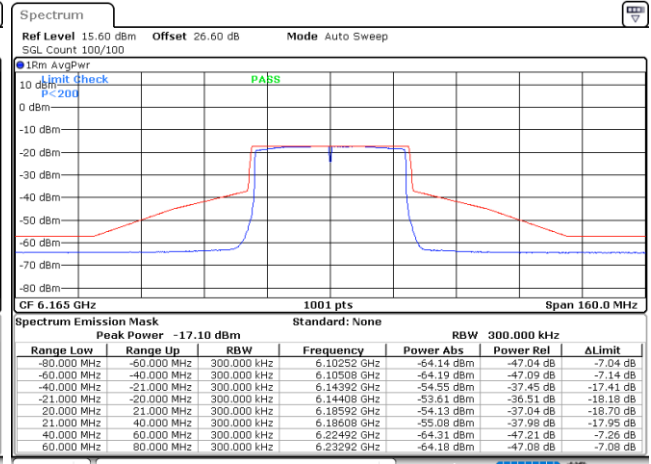

Date: 27.NOV.2021 23:00:28

Plot on Channel 6405MHz

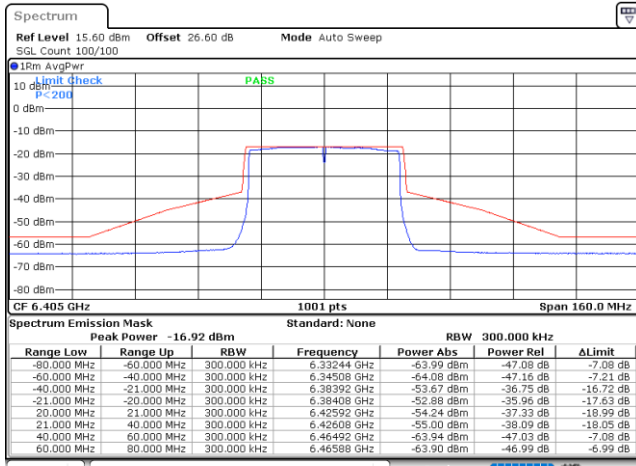

Date: 27.NOV.2021 23:06:28

Plot on Channel 6445MHz

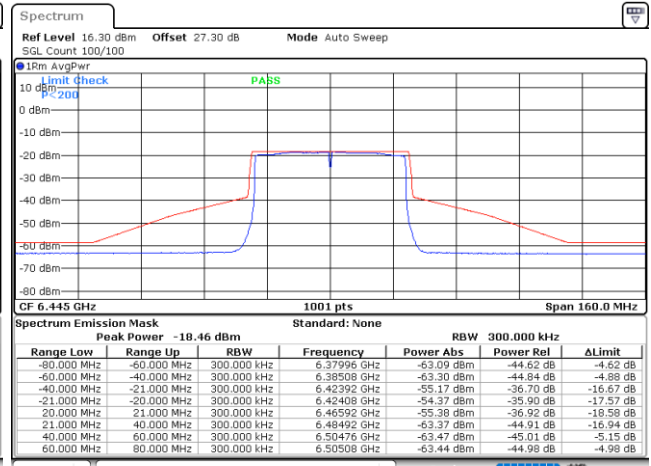

Date: 27.NOV.2021 23:11:16



Plot on Channel 6485MHz

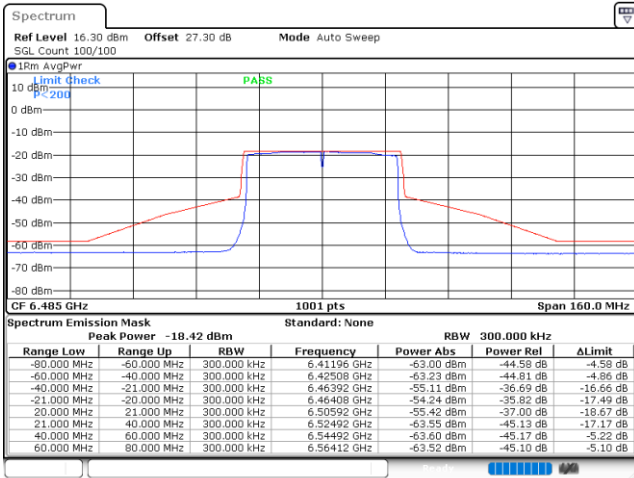

Date: 27.NOV.2021 23:16:35

Plot on Channel 6525MHz

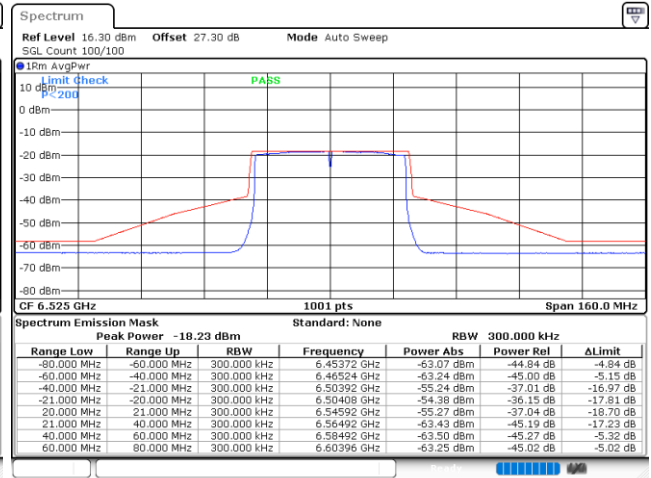

Date: 27.NOV.2021 23:21:33

Plot on Channel 6565MHz

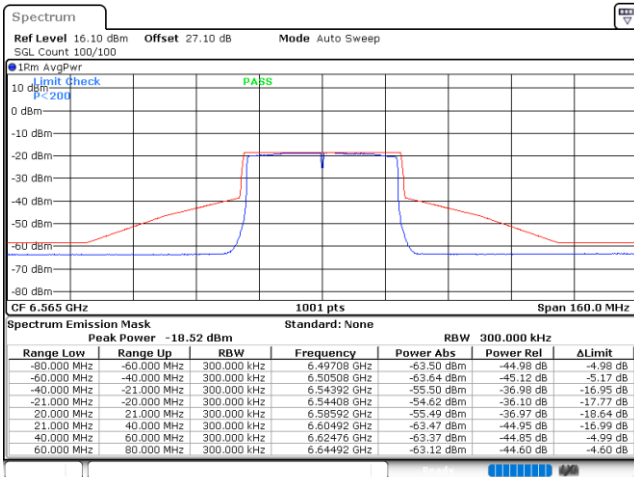

Date: 27.NOV.2021 23:25:34

Plot on Channel 6685MHz

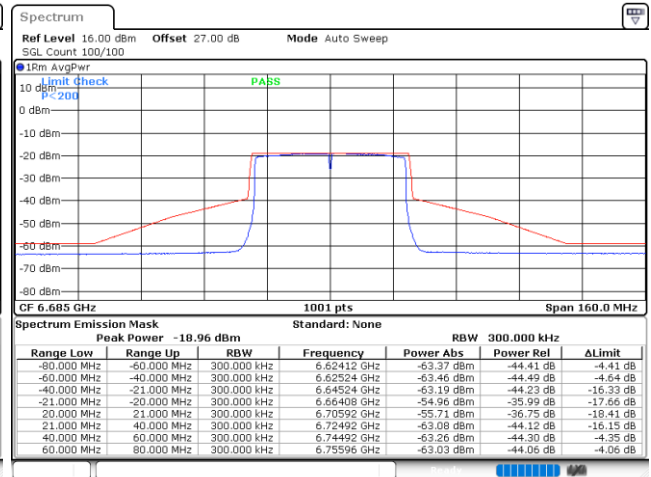

Date: 27.NOV.2021 23:30:06



Plot on Channel 6845MHz

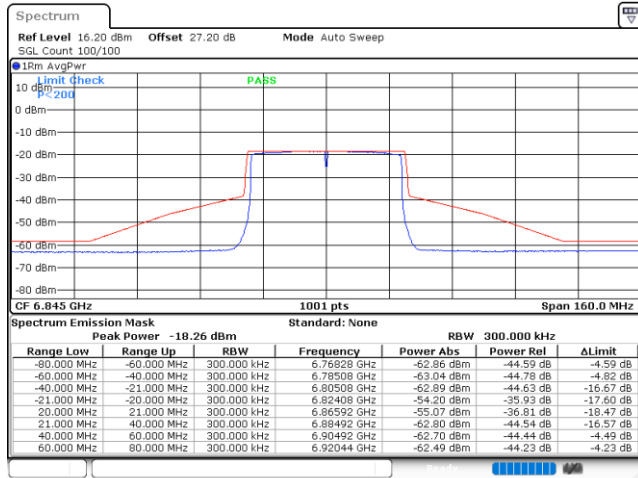

Date: 27.NOV.2021 23:36:11

Plot on Channel 6885MHz

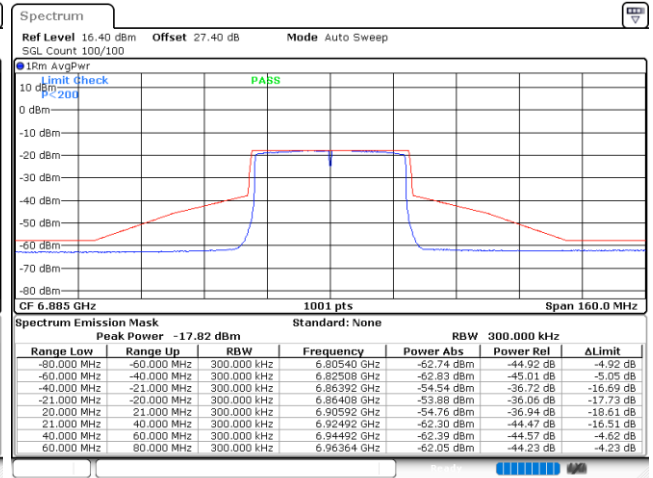

Date: 27.NOV.2021 23:42:03

Plot on Channel 6965MHz

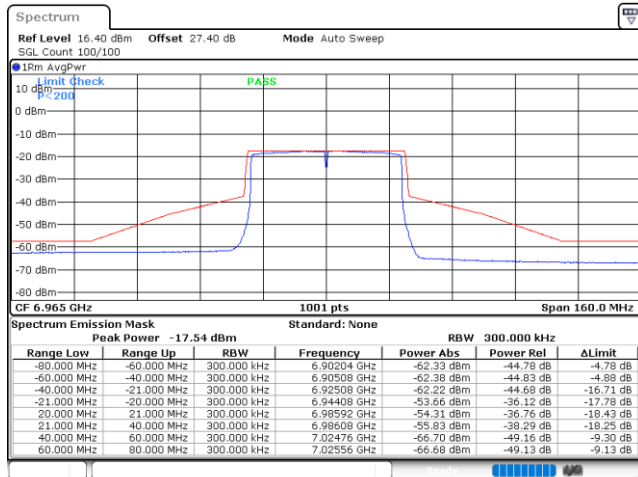

Date: 27.NOV.2021 23:51:58

Plot on Channel 7085MHz

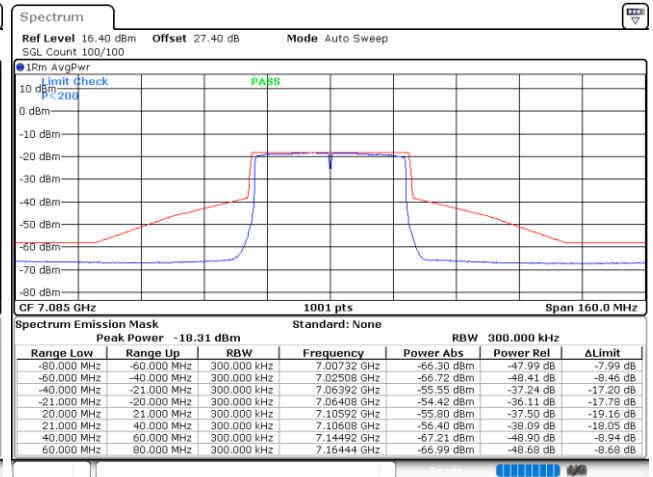

Date: 27.NOV.2021 23:55:42



EUT Mode : 802.11ax HE80

Plot on Channel 5985MHz

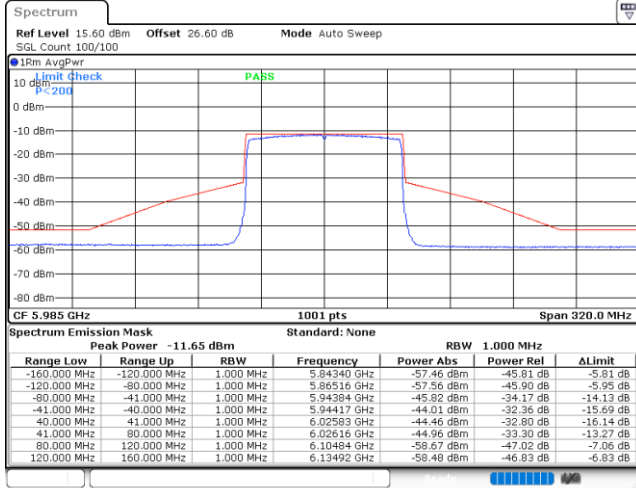

Date: 27.NOV.2021 05:25:58

Plot on Channel 6145MHz

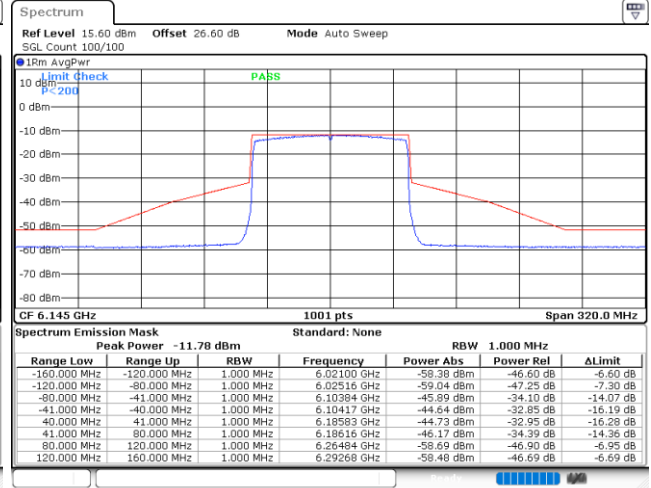

Date: 27.NOV.2021 05:30:23

Plot on Channel 6385MHz

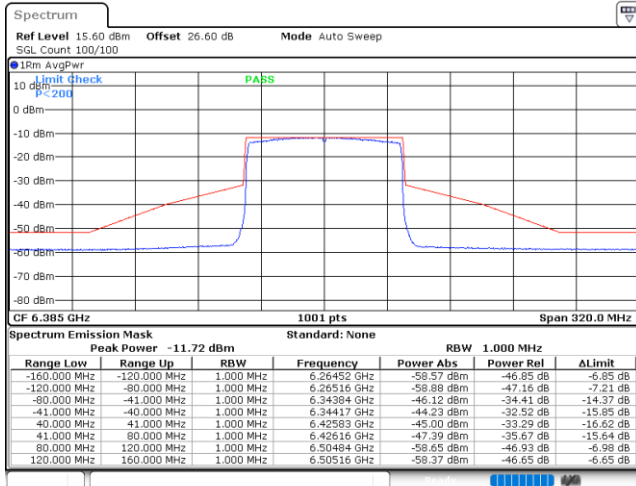

Date: 27.NOV.2021 05:34:45

Plot on Channel 6465MHz

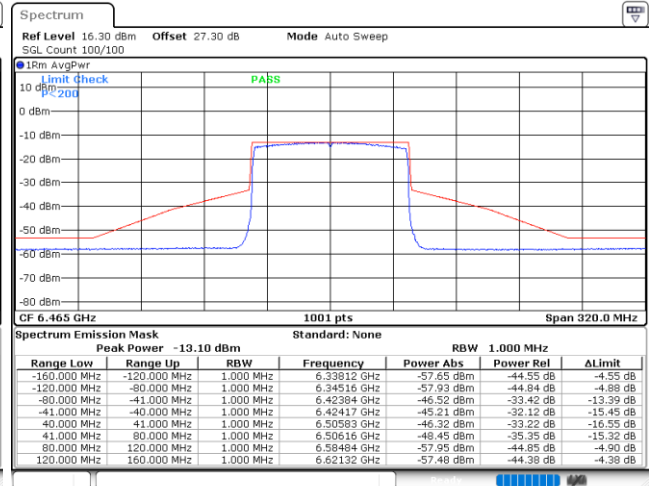

Date: 27.NOV.2021 05:42:20



Plot on Channel 6545MHz

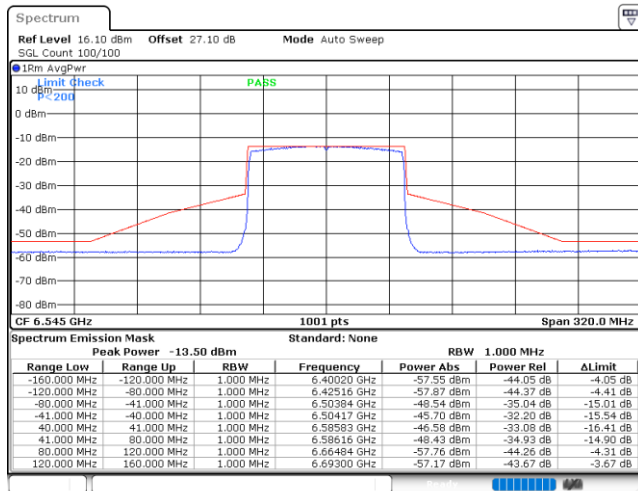

Date: 27.NOV.2021 05:52:03

Plot on Channel 6625MHz

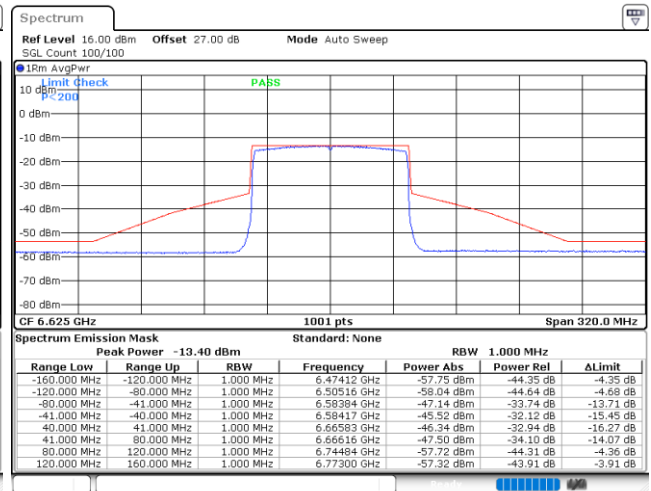

Date: 27.NOV.2021 06:01:18

Plot on Channel 6785MHz

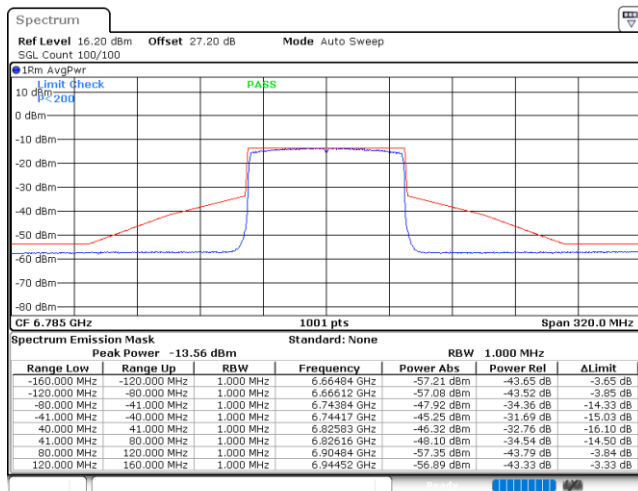

Date: 27.NOV.2021 06:12:39

Plot on Channel 6865MHz

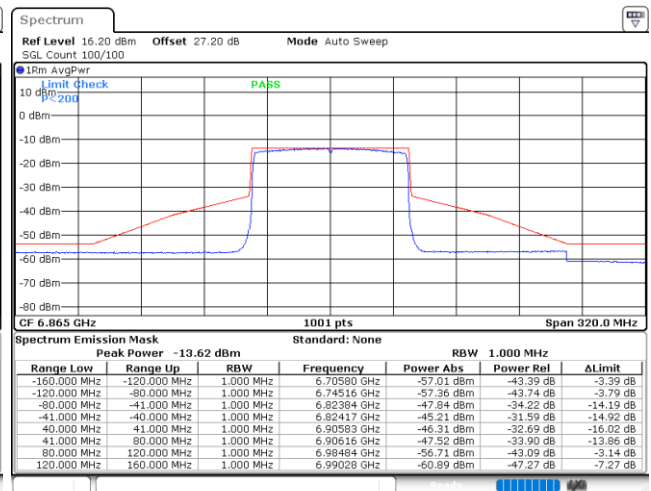

Date: 27.NOV.2021 06:24:02



Plot on Channel 6945MHz

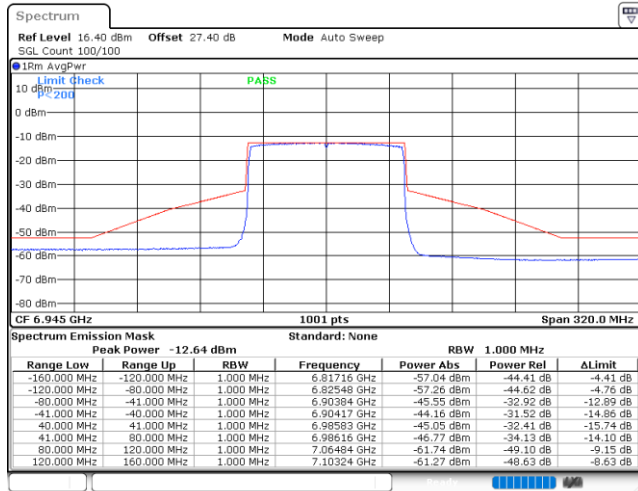

Date: 27.NOV.2021 06:32:20

Plot on Channel 7025MHz

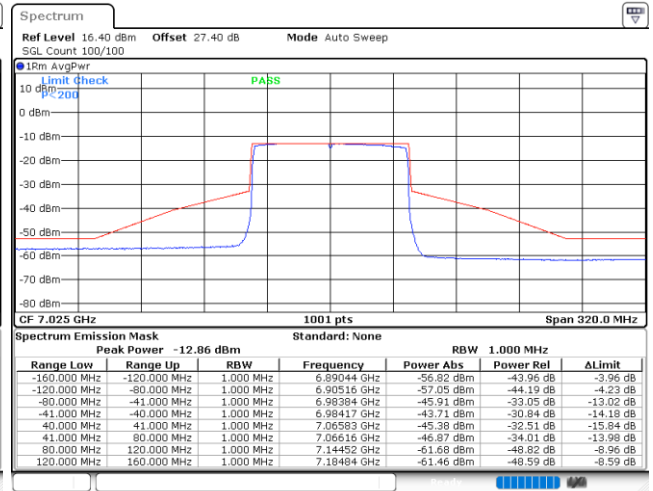

Date: 27.NOV.2021 06:39:21



EUT Mode : 802.11ax HE160

Plot on Channel 6025MHz

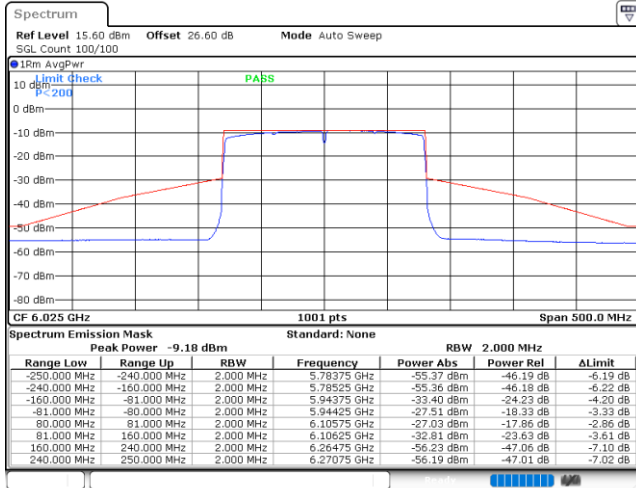

Date: 27.NOV.2021 03:36:35

Plot on Channel 6185MHz

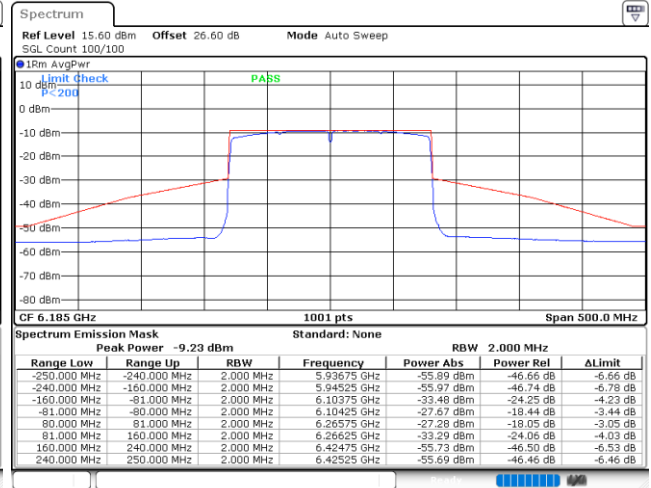

Date: 27.NOV.2021 04:31:16

Plot on Channel 6345MHz

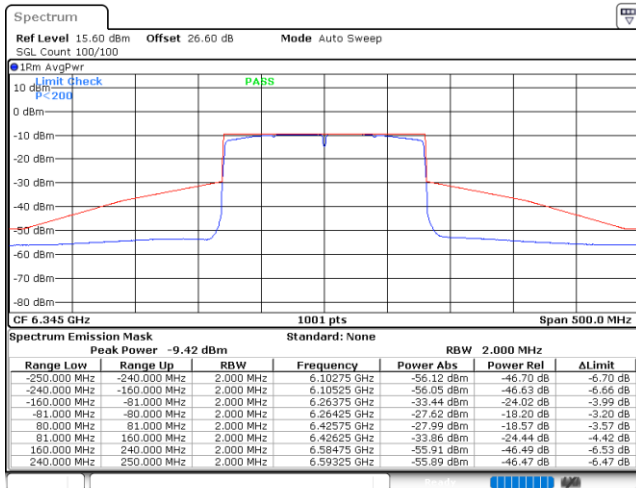

Date: 27.NOV.2021 04:42:36

Plot on Channel 6505MHz

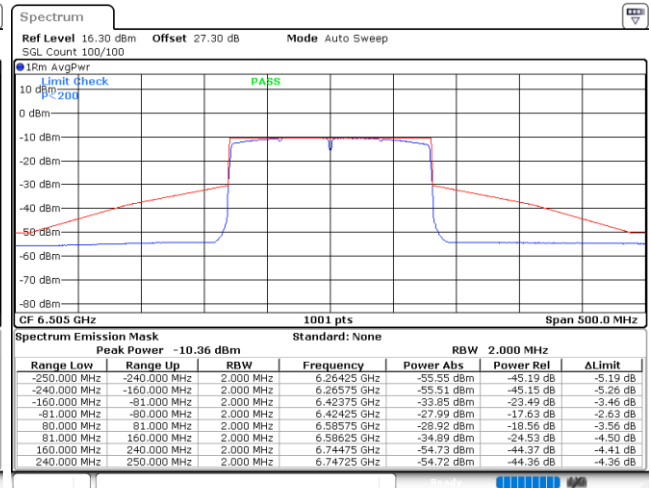

Date: 27.NOV.2021 05:00:24



Plot on Channel 6665MHz

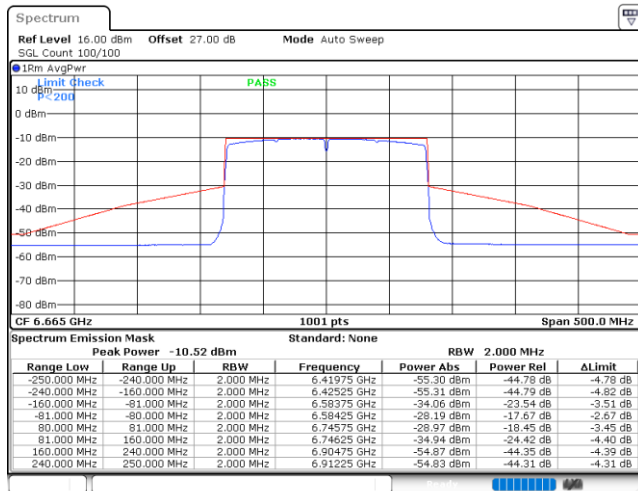

Date: 27.NOV.2021 05:04:55

Plot on Channel 6825MHz

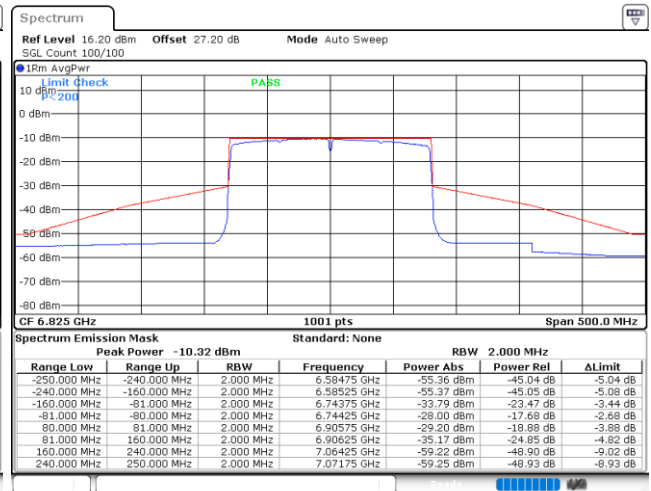

Date: 27.NOV.2021 05:10:03

Plot on Channel 6985MHz

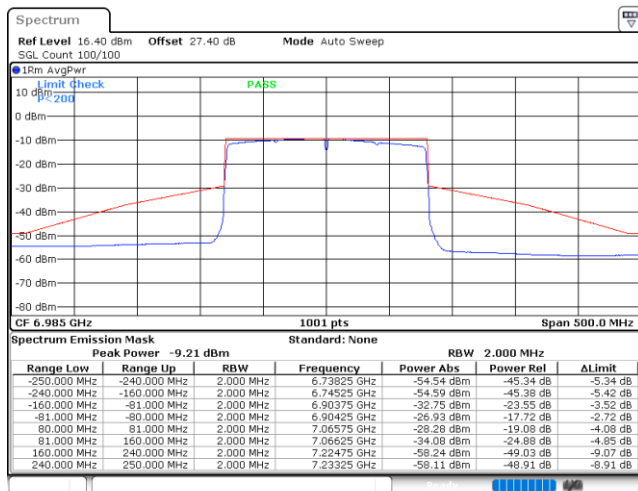

Date: 27.NOV.2021 05:15:56



3.5 Contention Based Protocol

3.5.1 Limit of Contention Based Protocol

<FCC 14-30 CFR 15.407>

(d)(6) Indoor access points, subordinate devices and client devices operating in the 5.925-7.125 GHz band must employ a contention-based protocol.

FCC KDB 987594 D02 U-NII 6GHz EMC Measurement v01

Unlicensed low-power indoor devices must detect co-channel radio frequency power that is at least -62 dBm or lower. Upon detection of energy in the band, unlicensed low power indoor devices must vacate the channel and stay off the channel as long as detected radio frequency power is equal to or greater than the threshold (-62 dBm). The -62 dBm (or lower) threshold is referenced to a 0 dBi antenna gain. To ensure incumbent operations are reliably detected in the band, low power indoor devices must detect RF energy throughout their intended operating channel. For example, an 802.11 device that plans to transmit a 40 MHz- wide signal (on a primary 20 MHz channel and a secondary 20 MHz channel) must detect energy throughout the entire 40 MHz channel. Additionally, low-power indoor devices must detect co-channel energy with 90% or greater certainty.

Table 1. Criteria to determine number of times detection threshold test may be performed

If	Number of Tests	Placement of Incumbent Transmission
$BW_{EUT} \leq BW_{Inc}$	Once	Tune incumbent and EUT transmissions ($f_{c1} = f_{c2}$)
$BW_{Inc} < BW_{EUT} \leq 2BW_{Inc}$	Once	Incumbent transmission is contained within BW_{EUT}
$2BW_{Inc} < BW_{EUT} \leq 4BW_{Inc}$	Twice. Incumbent transmission is contained within BW_{EUT}	Incumbent transmission is located as closely as possible to the lower edge and upper edge, respectively, of the EUT channel
$BW_{EUT} > 4BW_{Inc}$	Three times	Incumbent transmission is located as closely as possible to the lower edge of the EUT channel, in the middle of EUT channel, and as closely as possible to the upper edge of the EUT channel

where:

BW_{EUT} : Transmission bandwidth of EUT signal

BW_{Inc} : Transmission bandwidth of the simulated incumbent signal (10 MHz wide AWGN signal)

f_{c1} : Center frequency of EUT transmission

f_{c2} : Center frequency of simulated incumbent signal

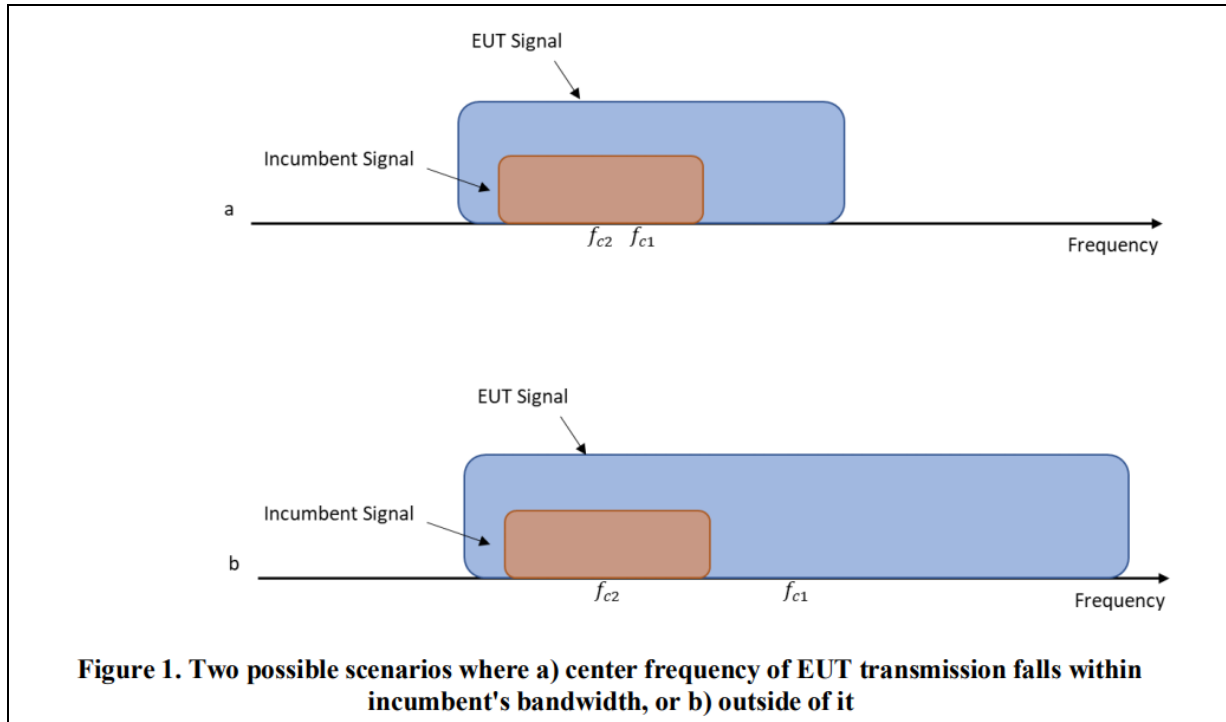

3.5.2 Measuring Instruments

Please refer to the measuring equipment list in this test report.

3.5.3 Test Procedures

Refer to KDB 987594 D02 v01v01.

1. To ensure EUT reliably detects an incumbent signal in both scenarios shown in Figure 1, the detection threshold test may be repeated more than once with the incumbent signal (having center frequency f_{c2}) tuned to different center frequencies within the UT transmission bandwidth. The criteria specified in Table 1 determines how many times the detection threshold test must be performed;
2. Using an AWGN signal source, generate (but do not transmit, i.e., RF OFF) a 10 MHz-wide AWGN signal. Use Table 1 to determine the center frequency of the 10 MHz AWGN signal relative to the EUT's channel bandwidth and center frequency.
3. Monitor the signal analyzer to verify if the AWGN signal has been detected and the EUT has ceased transmission. If the EUT continues to transmit, then incrementally increase the AWGN signal power level until the EUT stops transmitting.
4. (Including all losses in the RF paths) Determine and record the AWGN signal power level (at the EUT's antenna port) at which the EUT ceased transmission. Repeat the procedure at least 10 times to verify the EUT can detect an AWGN signal with 90% (or better) level of certainty.

5. Refer to Table 1 to determine number of times the detection threshold testing needs to be repeated. If testing is required more than once, then go back to step 2, choose a different center frequency for the AWGN signal and repeat the process.

3.5.4 Test Setup

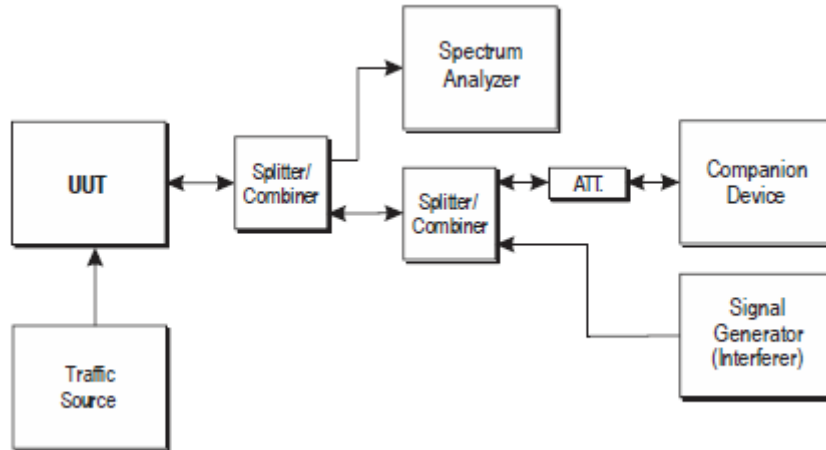

3.5.5 Support Unit used in test configuration and system

Instrument	Brand Name	Model No.	Characteristics
WLAN AP	Netgear	MR6500	Dual Band AP
Notebook	Acer	N15C1	LAN



3.5.6 Test Summary of Contention Based Protocol Test

Test Engineer :	Kai Liao	Temperature :	24~26°C
		Relative Humidity :	45~50%

Band	Channel Freq. (MHz)	Channel BW (MHz)	Incumbent freq. (MHz)	Measured Detection level (dBm)	Detection Rate (%)	Regulated Threshold level (dBm)	Margin (dB)
UNII Band 5	6135	20	6135	-71.28	100	-60.46	10.82
	6185	160	6110	-68.23	100	-60.46	7.77
			6185	-63.49	100	-60.46	3.03
			6260	-68.6	100	-60.46	8.14
UNII Band 6	6455	20	6455	-70.74	100	-60.46	10.28
	6505	160	6430	-67.84	100	-60.46	7.38
			6505	-62.98	100	-60.46	2.52
			6580	-66.97	100	-60.46	6.51
UNII Band 7	6695	20	6695	-70.17	100	-60.46	9.71
	6665	160	6590	-68.08	100	-60.46	7.62
			6665	-63.19	100	-60.46	2.73
			6740	-67.2	100	-60.46	6.74
UNII Band 8	7015	20	7015	-70.36	100	-60.46	9.9
	6985	160	6910	-67.07	100	-60.46	6.61
			6985	-61.8	100	-60.46	1.34
			7060	-67.01	100	-60.46	6.55

Note: Threshold Level (TL) = -62dBm + minimum antenna gain



3.5.7 Test Plots of Contention Based Protocol Test

Contention Based Protocol Result Plots on U-NII 5 (AWGN Interference)

802.11ax (HE20) / 6135MHz
Threshold Level (TL) = -71.28dBm

802.11ax (HE20) / CH37
Test result is pass due to no transmission occur.

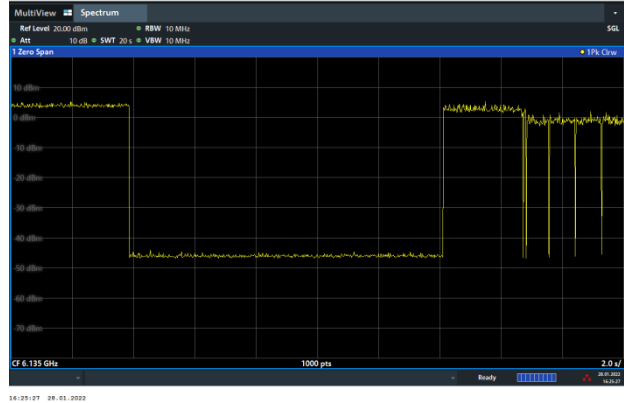
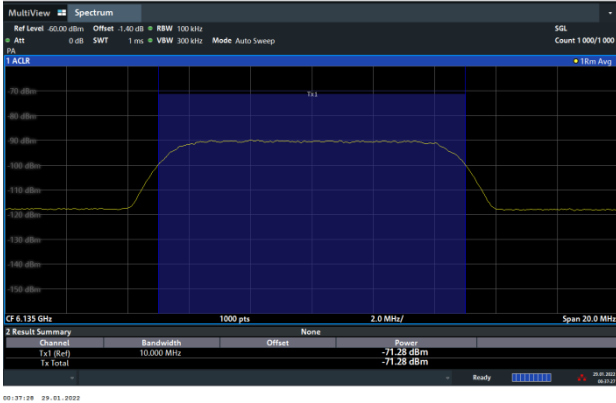

802.11ax (HE160) / 6110MHz (Lower edge)
Threshold Level (TL) = -68.23dBm

802.11ax (HE160) / CH47 (Lower edge)
Test result is pass due to no transmission occur.

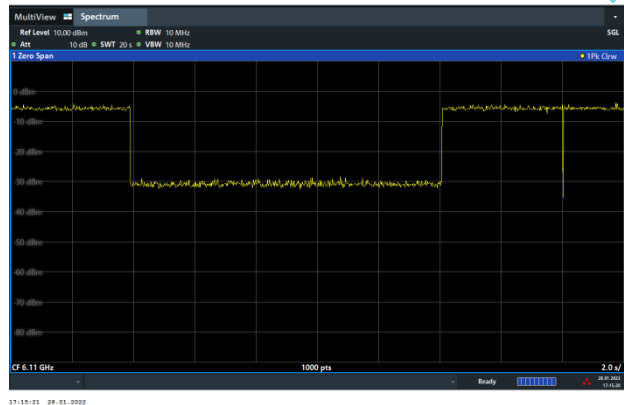
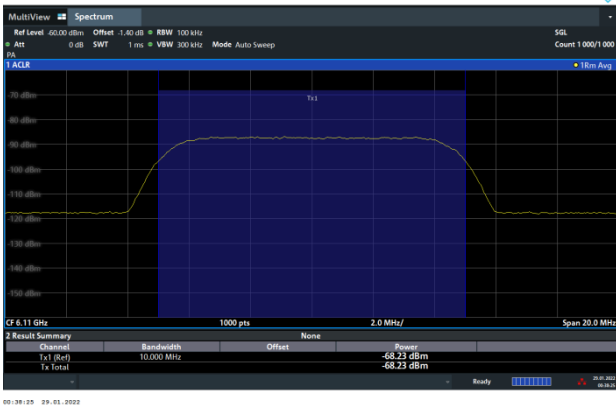



802.11ax (HE160) / 6185MHz (Middle)
Threshold Level (TL) = -63.49dBm

802.11ax (HE160) / CH47 (Middle)
Test result is pass due to no transmission occur.

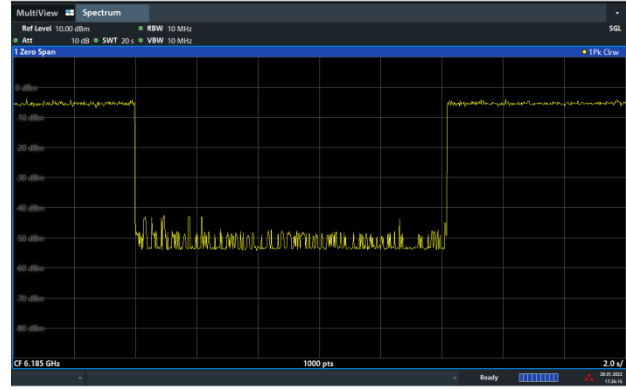
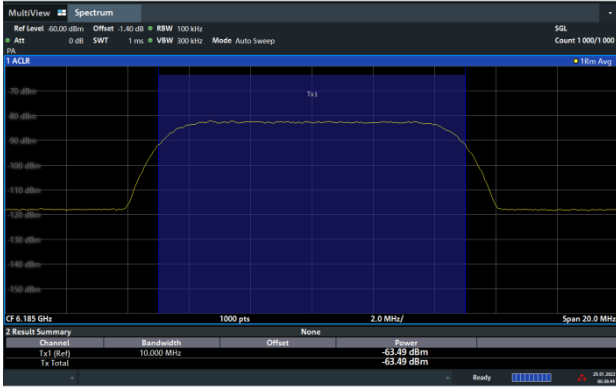

802.11ax (HE160) / 6260MHz (Upper edge)
Threshold Level (TL) = -68.6dBm

802.11ax (HE160) / CH47 (Upper edge)
Test result is pass due to no transmission occur.

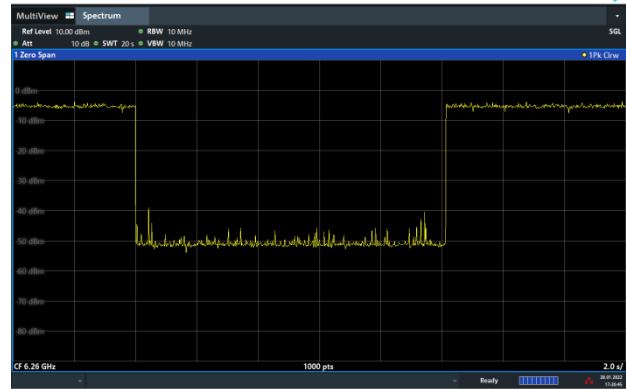
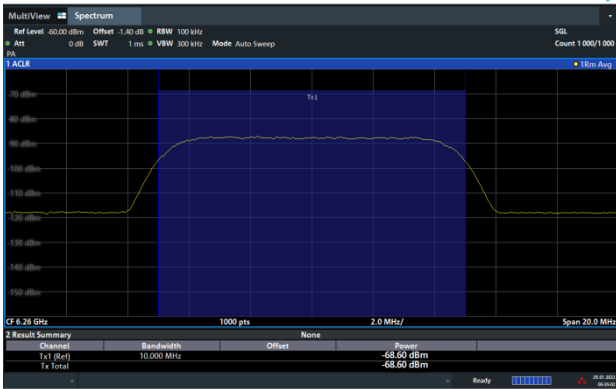



Contention Based Protocol Result Plots on U-NII 6 (AWGN Interference)

802.11ax (HE20) / 6455MHz
Threshold Level (TL) = -70.74dBm

802.11ax (HE20) / CH101
Test result is pass due to no transmission occur.

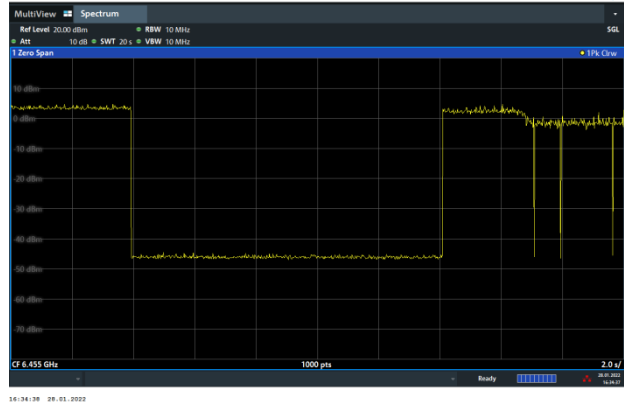
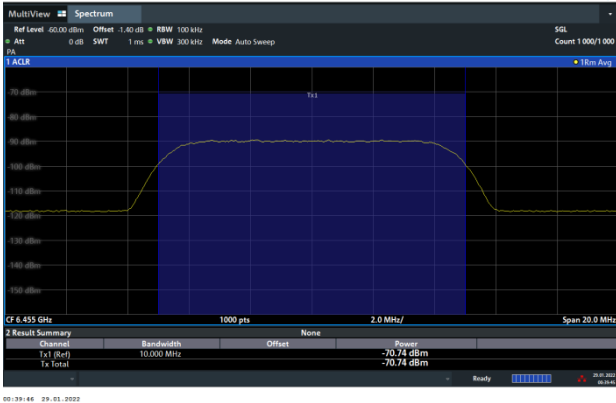

802.11ax (HE160) / 6430MHz (Lower edge)
Threshold Level (TL) = -67.84dBm

802.11ax (HE160) / CH111 (Lower edge)
Test result is pass due to no transmission occur.

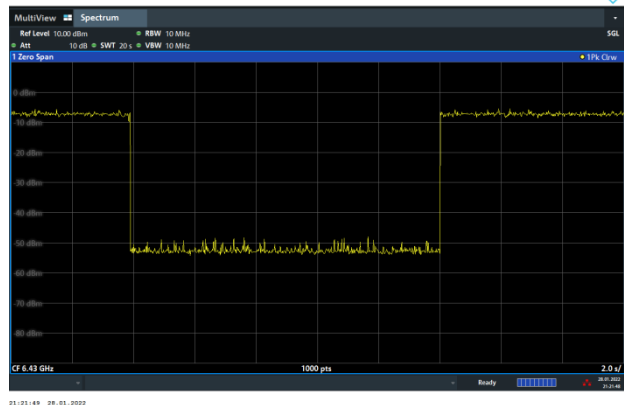
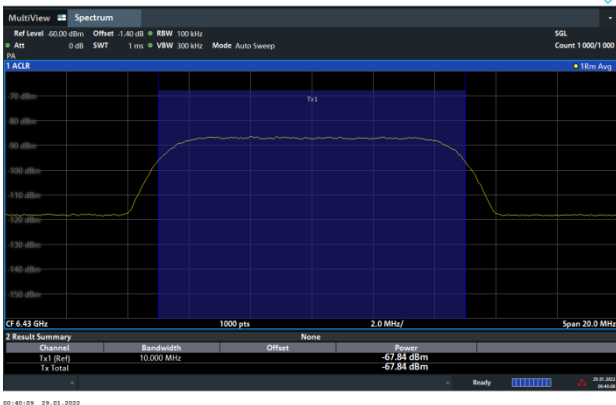



802.11ax (HE160) / 6505MHz (Middle)
Threshold Level (TL) = -62.98dBm

802.11ax (HE160) / CH111 (Middle)
Test result is pass due to no transmission occur.

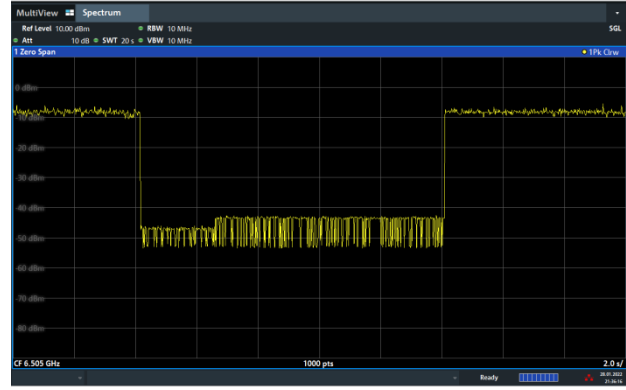
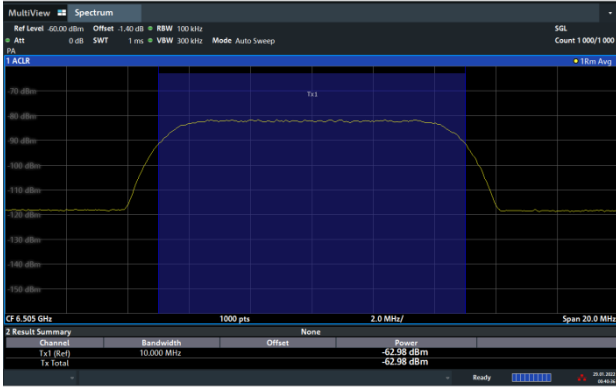

802.11ax (HE160) / 6580MHz (Upper edge)
Threshold Level (TL) = -66.97dBm

802.11ax (HE160) / CH111 (Upper edge)
Test result is pass due to no transmission occur.

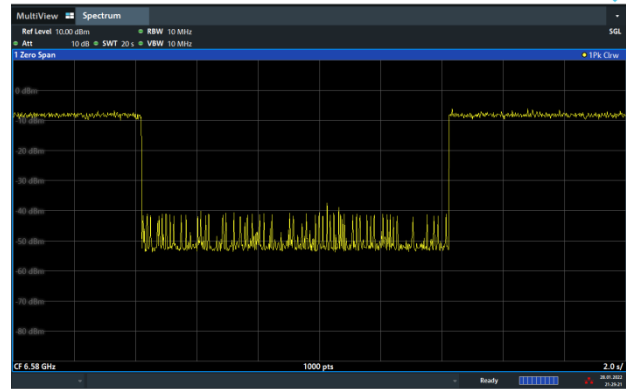
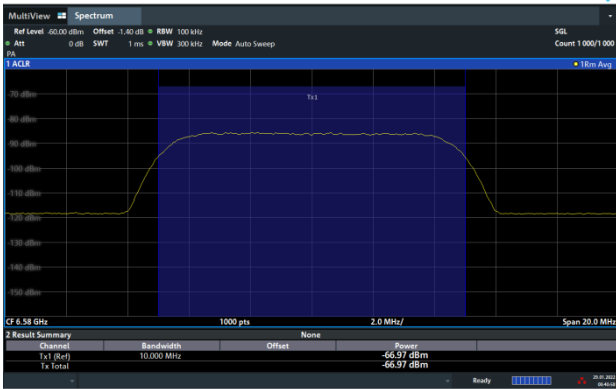



Contention Based Protocol Result Plots on U-NII 7 (AWGN Interference)

802.11ax (HE20) / 6695MHz
Threshold Level (TL) = -70.17dBm

802.11ax (HE20) / CH149
Test result is pass due to no transmission occur.

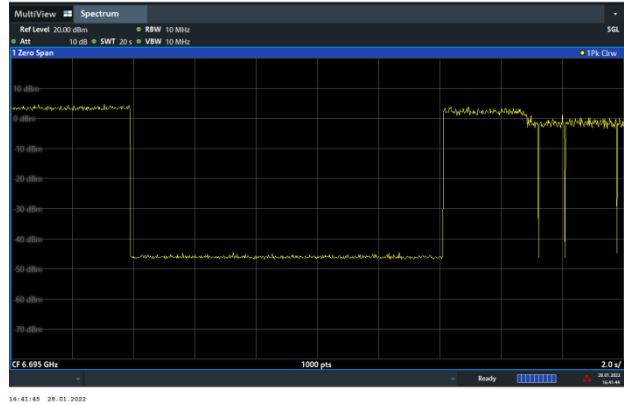
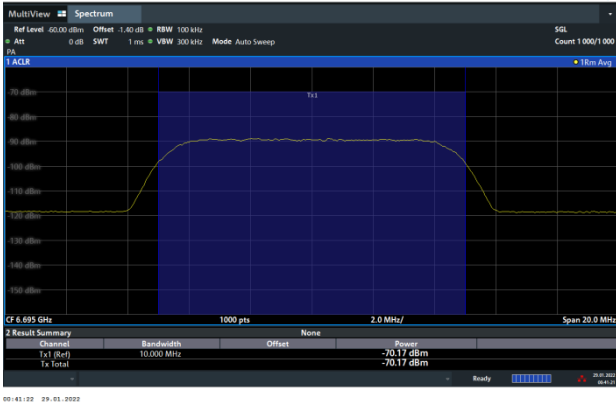

802.11ax (HE160) / 6590MHz (Lower edge)
Threshold Level (TL) = -68.08dBm

802.11ax (HE160) / CH143 (Lower edge)
Test result is pass due to no transmission occur.

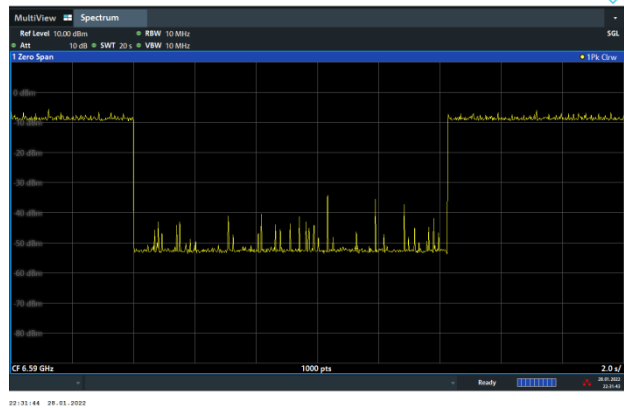
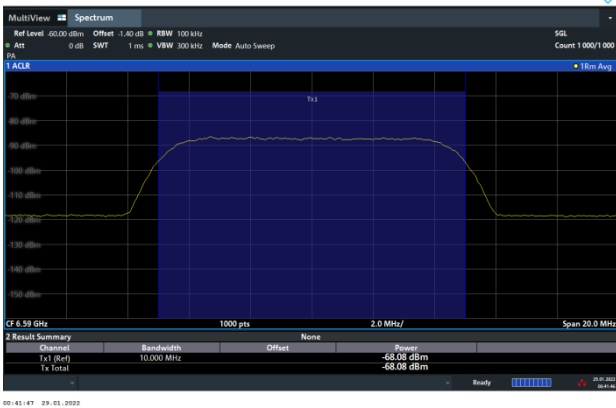



802.11ax (HE160) / 6665MHz (Middle)
Threshold Level (TL) = -63.19dBm

802.11ax (HE160) / CH143 (Middle)
Test result is pass due to no transmission occur.

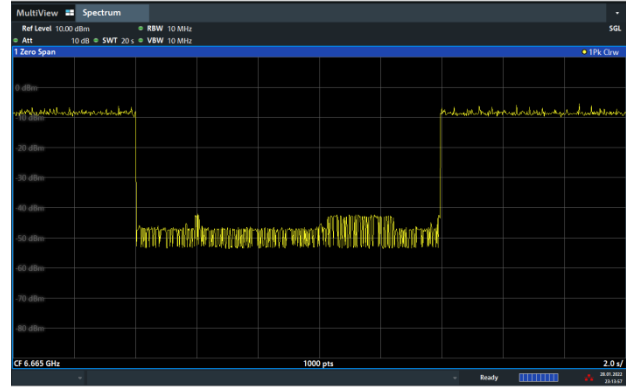
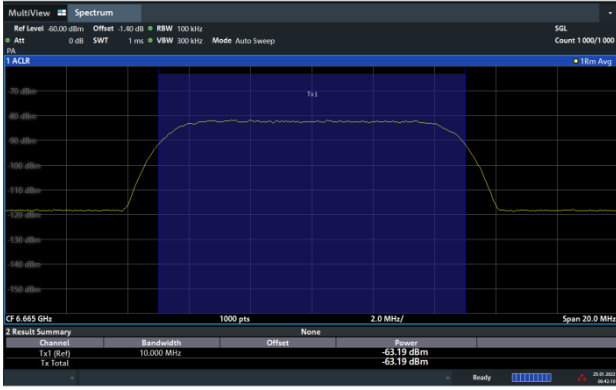

802.11ax (HE160) / 6740MHz (Upper edge)
Threshold Level (TL) = -67.20dBm

802.11ax (HE160) / CH143 (Upper edge)
Test result is pass due to no transmission occur.

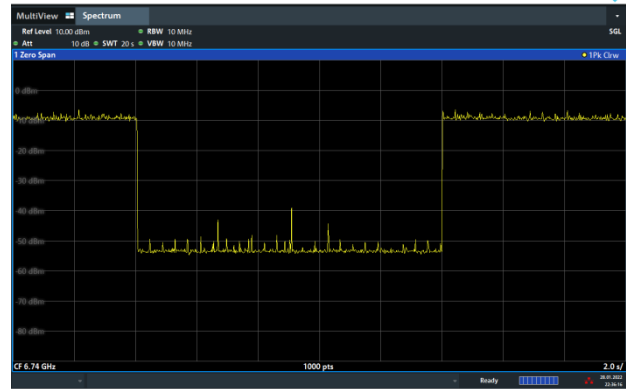
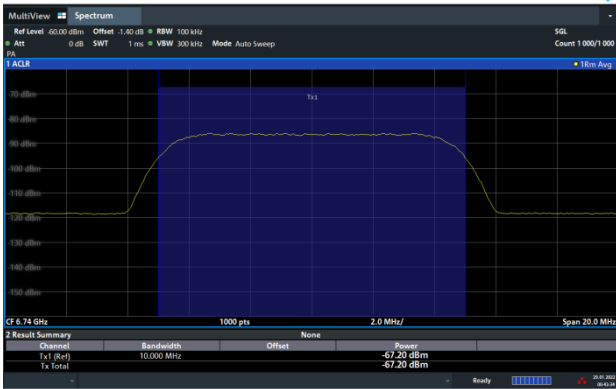



Contention Based Protocol Result Plots on U-NII 8 (AWGN Interference)

802.11ax (HE20) / 7015MHz
Threshold Level (TL) = -70.36dBm

802.11ax (HE20) / CH213
Test result is pass due to no transmission occur.

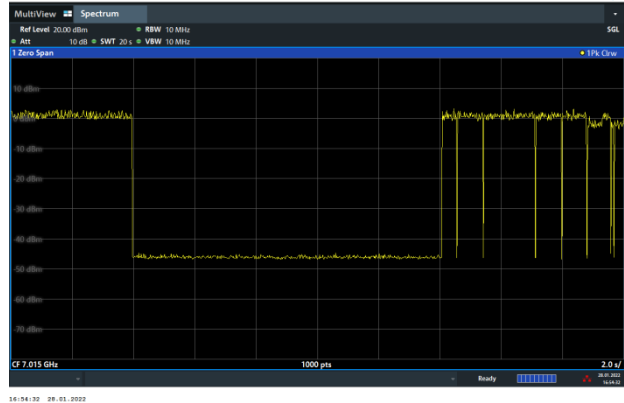
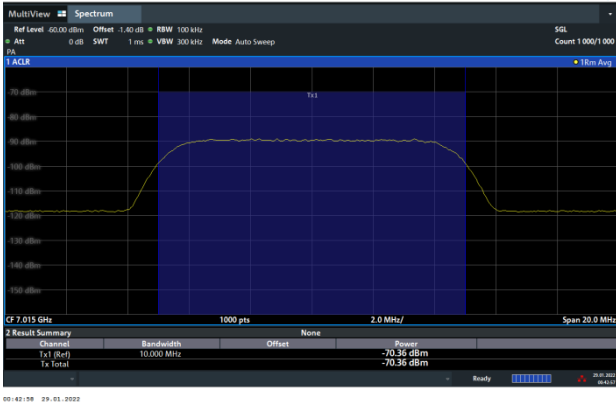

802.11ax (HE160) / 6910MHz (Lower edge)
Threshold Level (TL) = -67.07dBm

802.11ax (HE160) / CH207 (Lower edge)
Test result is pass due to no transmission occur.

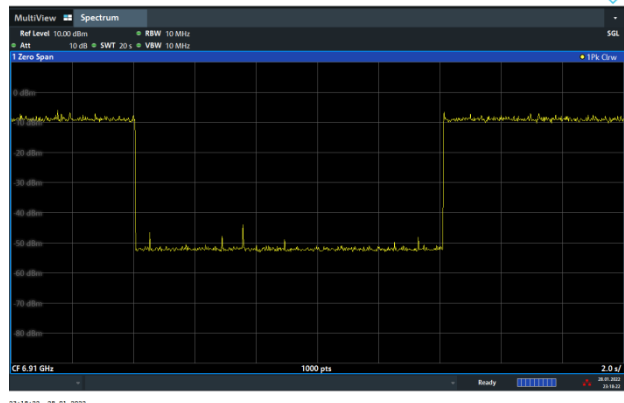
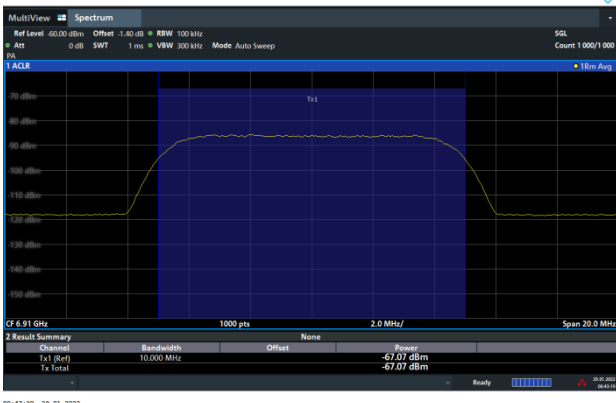



802.11ax (HE160) / 6985MHz (Middle)
Threshold Level (TL) = -61.8dBm

802.11ax (HE160) / CH207 (Middle)
Test result is pass due to no transmission occur.

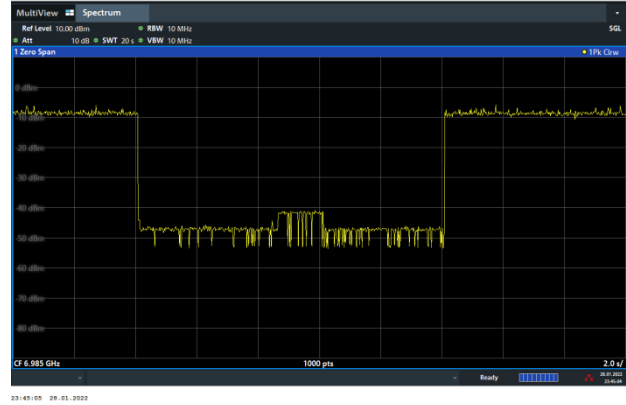
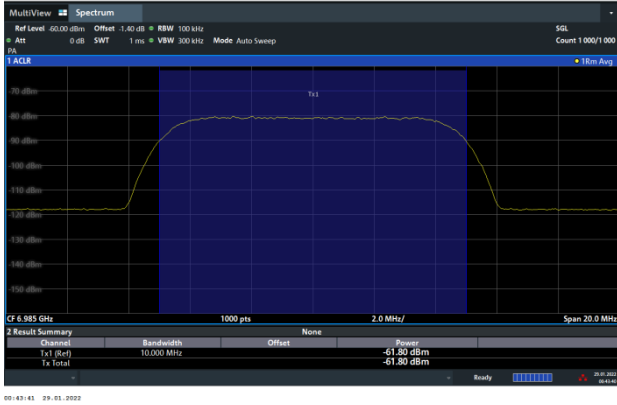

802.11ax (HE160) / 7060MHz (Upper edge)
Threshold Level (TL) = -67.01dBm

802.11ax (HE160) / CH207 (Upper edge)
Test result is pass due to no transmission occur.

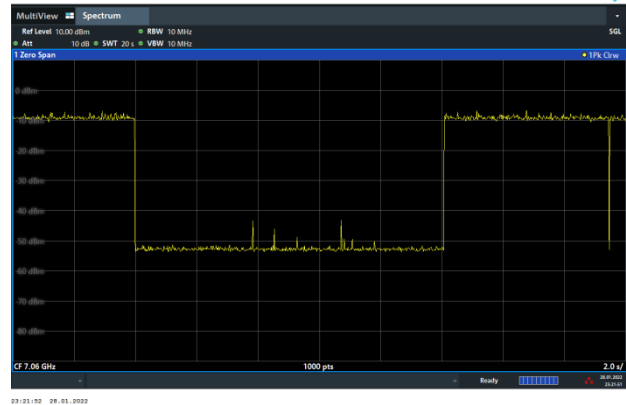
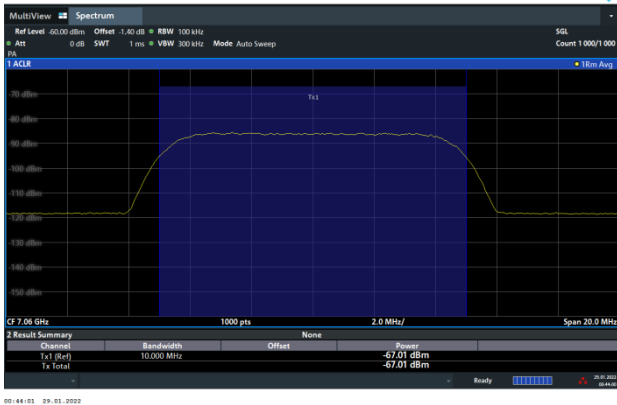

3.6 Unwanted Emissions Measurement

This section is to measure unwanted emissions through radiated measurement for band edge spurious emissions and out of band emissions measurement.

3.6.1 Limit of Unwanted Emissions

- (1) For transmitters operating within the 5.925-7.125 GHz band: Any emissions outside of the 5.925-7.125 GHz band must not exceed an e.i.r.p. of -27 dBm/MHz.

EIRP (dBm)	Field Strength at 3m (dBμV/m)
- 27 (RMS)	68.3
- 7 (Peak)	88.3

According 987594 D02 U-NII 6GHz EMC Measurement v01 section G:

Unwanted emissions outside of restricted bands are measured with a RMS detector.

In addition, 15.35(b) applies where the peak emissions must be limited to no more than 20 dB above the average limit

- (2) Unwanted spurious emissions fallen in restricted bands shall comply with the general field strength limits as below table:

Frequency (MHz)	Field Strength (microvolts/meter)	Measurement Distance (meters)
0.009 – 0.490	2400/F(kHz)	300
0.490 – 1.705	24000/F(kHz)	30
1.705 – 30.0	30	30
30 – 88	100	3
88 – 216	150	3
216 - 960	200	3
Above 960	500	3

Note: The following formula is used to convert the EIRP to field strength.

$$E = \frac{1000000\sqrt{30P}}{3} \mu\text{V/m, where P is the eirp (Watts)}$$

3.6.2 Measuring Instruments

Please refer to the measuring equipment list in this test report.



3.6.3 Test Procedures

1. The testing follows FCC KDB 789033 D02 General UNII Test Procedures New Rules v02r01. Section G) Unwanted emissions measurement.
 - (1) Procedure for Unwanted Emissions Measurements Below 1000MHz
 - RBW = 120 kHz
 - VBW = 300 kHz
 - Detector = Peak
 - Trace mode = max hold
 - (2) Procedure for Peak Unwanted Emissions Measurements Above 1000 MHz
 - RBW = 1 MHz
 - VBW \geq 3 MHz
 - Detector = Peak
 - Sweep time = auto
 - Trace mode = max hold
 - (3) Procedures for Average Unwanted Emissions Measurements Above 1000MHz
 - RBW = 1 MHz
 - VBW = 10 Hz, when duty cycle is no less than 98 percent.
 - VBW \geq 1/T, when duty cycle is less than 98 percent where T is the minimum transmission duration over which the transmitter is on and is transmitting at its maximum power control level for the tested mode of operation.
2. The EUT is placed on a turntable with 0.8 meter for frequency below 1 GHz and 1.5 meter for frequency above 1 GHz respectively above ground.
3. The EUT is set 3 meters away from the receiving antenna which is mounted on the top of a variable height antenna tower.
4. The antenna is a broadband antenna and its height is adjusted between one meter and four meters above ground to find the maximum value of the field strength for both horizontal polarization and vertical polarization of the antenna.
5. For each suspected emission, the EUT is arranged to its worst case and then adjust the antenna tower (from 1 m to 4 m) and turntable (from 0 degree to 360 degrees) to find the maximum reading.

6. Radiated testing below 1 GHz is performed by adjusting the antenna tower from 1 m to 4 m and by rotating the turn table from 0 degree to 360 degrees to find the peak maximum hold reading. When there is no suspected emission found and the emission level is with at least 6 dB margin against QP limit line, the position is marked as “-“.
7. Radiated testing above 1 GHz is performed by adjusting the antenna tower from 1 m to 4 m and by rotating the turn table from 0 degree to 360 degrees to find the peak maximum hold reading for scanning all frequencies. When there is no suspected emission found and the harmonic emission level is with at least 6 dB margin against average limit line, the position is marked as “-“.

3.6.4 Test Setup

For radiated emissions below 30MHz

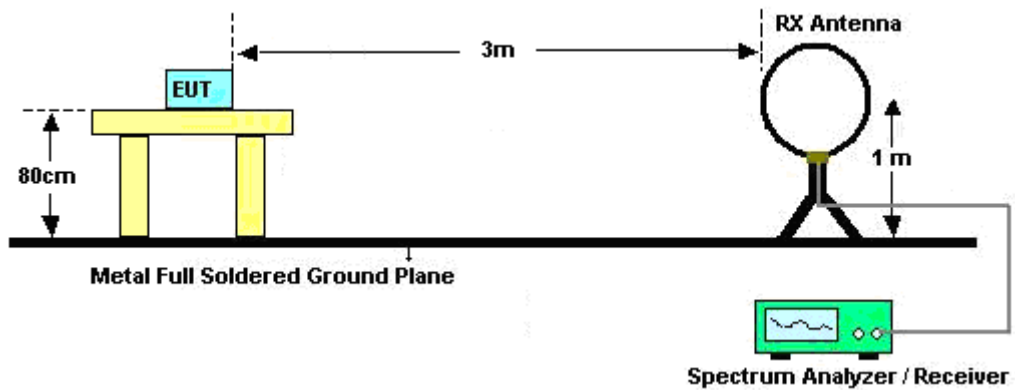

For radiated emissions from 30MHz to 1GHz

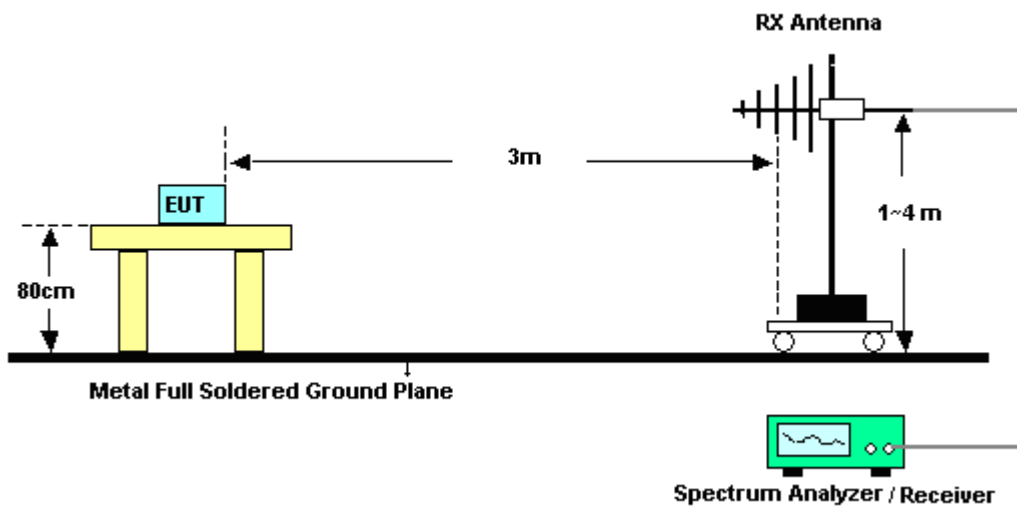

For radiated test from 1GHz to 18GHz

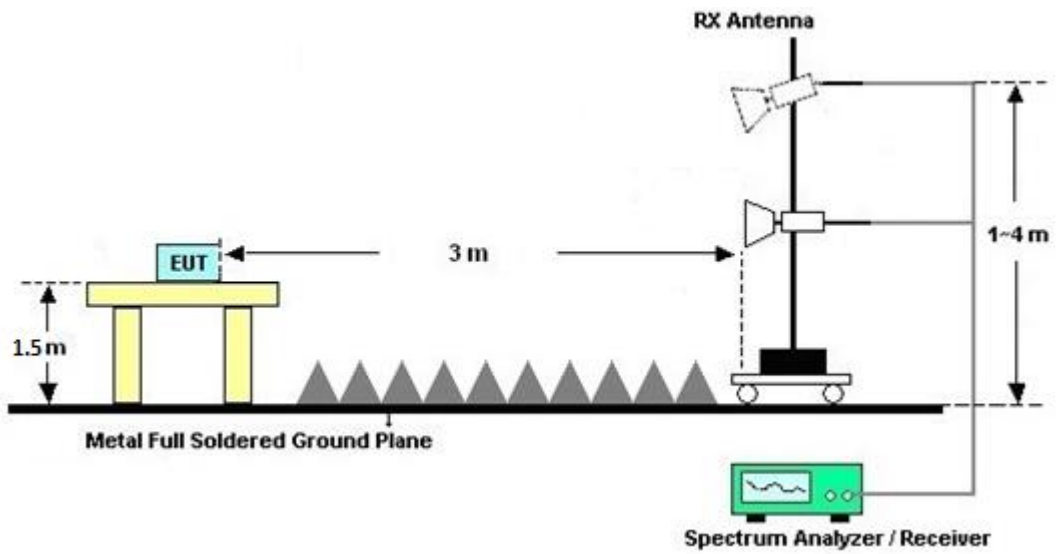

For radiated test above 18GHz

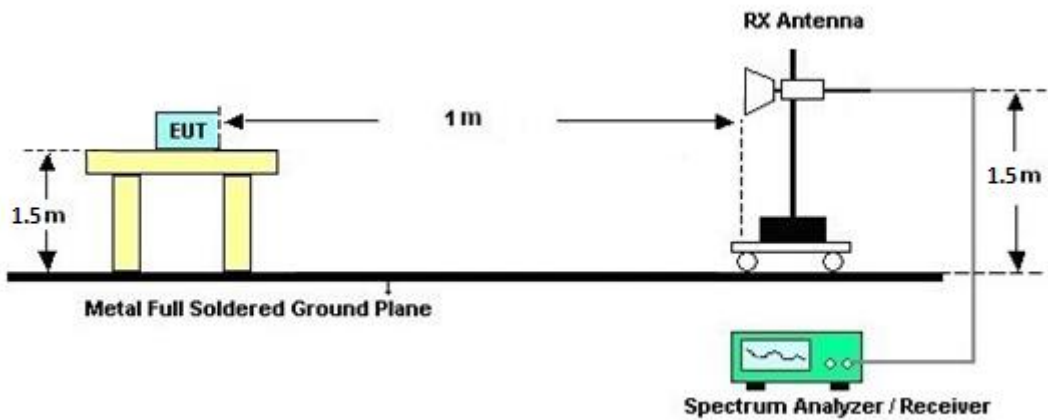



3.6.5 Test Results of Radiated Spurious Emissions (9 kHz ~ 30 MHz)

The low frequency, which starts from 9 kHz to 30 MHz, is pre-scanned and the result which is 20 dB lower than the limit line is not reported.

There is adequate comparison measurement of both open-field test site and alternative test site - semi-Anechoic chamber according to 414788 D01 Radiated Test Site v01r01, and the result came out very similar.

3.6.6 Test Result of Radiated Spurious at Band Edges

Please refer to Appendix C and D.

3.6.7 Duty Cycle

Please refer to Appendix E.

3.6.8 Test Result of Radiated Spurious Emissions (30MHz ~ 10th Harmonic)

Please refer to Appendix C and D.



3.7 AC Conducted Emission Measurement

3.7.1 Limit of AC Conducted Emission

For equipment that is designed to be connected to the public utility (AC) power line, the radio frequency voltage that is conducted back onto the AC power line on any frequency or frequencies within the band 150 kHz to 30 MHz shall not exceed the limits in the following table.

Frequency of emission (MHz)	Conducted limit (dB μ V)	
	Quasi-peak	Average
0.15-0.5	66 to 56*	56 to 46*
0.5-5	56	46
5-30	60	50

*Decreases with the logarithm of the frequency.

3.7.2 Measuring Instruments

Please refer to the measuring equipment list in this test report.

3.7.3 Test Procedures

1. The EUT is placed 0.4 meter away from the conducting wall of the shielding room, and is kept at least 80 centimeters from any other grounded conducting surface.
2. Connect EUT to the power mains through a line impedance stabilization network (LISN).
3. All the support units are connecting to the other LISN.
4. The LISN provides 50 ohm coupling impedance for the measuring instrument.
5. The FCC states that a 50 ohm, 50 microhenry LISN should be used.
6. Both Line and Neutral shall be tested in order to find out the maximum conducted emission.
7. The frequency range from 150 kHz to 30 MHz is scanned.
8. Set the test-receiver system to Peak Detect Function and specified bandwidth with Maximum Hold Mode.

3.7.4 Test Setup

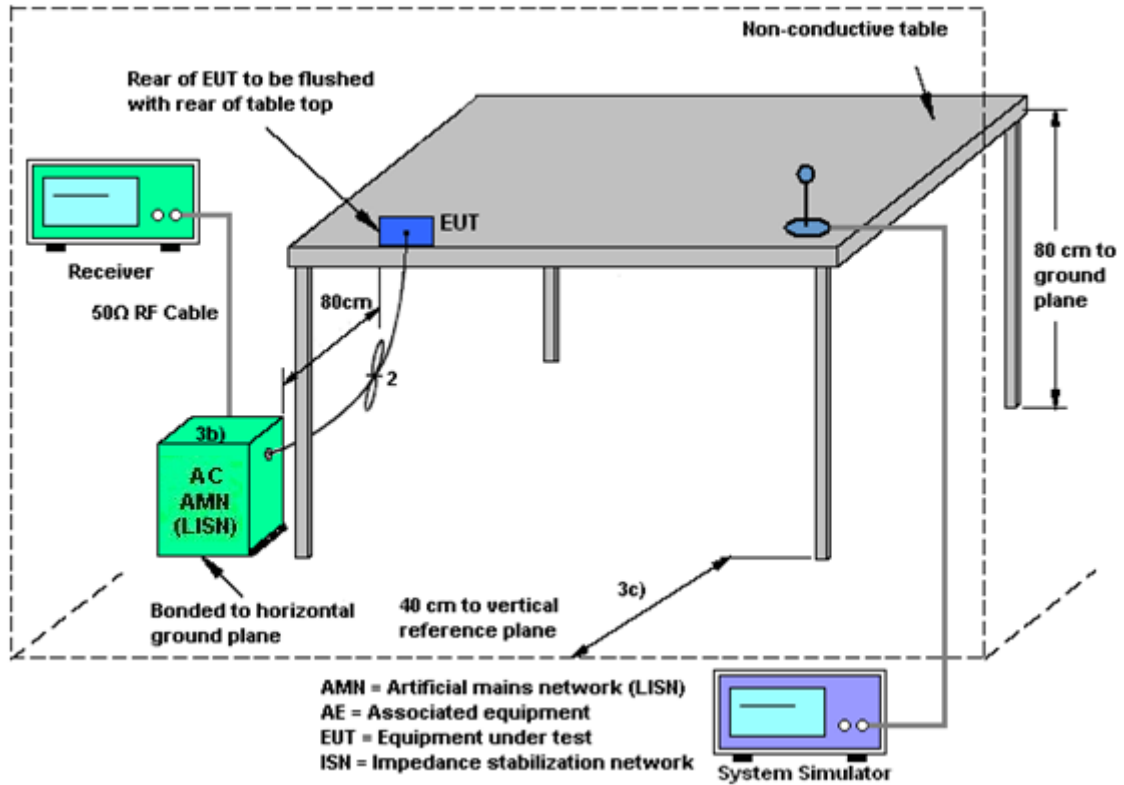

3.7.5 Test Result of AC Conducted Emission

Please refer to Appendix B.

3.8 Antenna Requirements

3.8.1 Antenna Anti-Replacement Construction

An embedded-in antenna design is used.

3.8.2 Antenna Gain

FCC KDB 662911 D01 Multiple Transmitter Output v02r01

For CDD transmissions, directional gain is calculated as

Directional gain = G_{ANT} + Array Gain, where Array Gain is as follows.

For power spectral density (PSD) measurements on all devices,

Array Gain = $10 \log(N_{ANT}/N_{SS}=1)$ dB.

For power measurements on IEEE 802.11 devices,

Array Gain = 0 dB (i.e., no array gain) for $N_{ANT} \leq 4$.

Directional gain may be calculated by using the formulas applicable to equal gain antennas with

G_{ANT} set equal to the gain of the antenna having the highest gain;

The EUT supports CDD mode.

For power, the directional gain G_{ANT} is set equal to the antenna having the highest gain, i.e.,

F)2)f)i).

For PSD, the directional gain calculation is following F)2)f)ii) of KDB 662911 D01 v02r01.

The directional gain “DG” is calculated as following table.

$$DirectionalGain = 10 \cdot \log \left[\frac{\sum_{j=1}^{N_{SS}} \left\{ \sum_{k=1}^{N_{ANT}} g_{j,k} \right\}^2}{N_{ANT}} \right]$$

where

Each antenna is driven by no more than one spatial stream;

N_{SS} = the number of independent spatial streams of data;

N_{ANT} = the total number of antennas

$g_{j,k} = 10^{G_k / 20}$ if the k th antenna is being fed by spatial stream j , or zero if it is not;

G_k is the gain in dBi of the k th antenna.



			DG	DG
			for	for
	Ant. 3	Ant. 4	Power	PSD
	(dBi)	(dBi)	(dBi)	(dBi)
5925 MHz ~ 6425 MHz	3.40	1.54	3.40	5.53
6425 MHz ~ 6525 MHz	3.40	1.54	3.40	5.53
6525 MHz ~ 6875 MHz	3.40	1.54	3.40	5.53
6875 MHz ~ 7125 MHz	3.40	1.54	3.40	5.53

Calculation example:

For the band 5925~6425MHz, the DG for PSD is derived from formula is

$$10 \times \log \left\{ \left[10^{(3.40 \text{ dBi} / 20)} + 10^{(1.54 \text{ dBi} / 20)} \right]^2 / 2 \right\}$$

= 5.53 dBi



4 List of Measuring Equipment

Instrument	Brand Name	Model No.	Serial No.	Characteristics	Calibration Date	Test Date	Due Date	Remark
Bilog Antenna	TESEQ	CBL 6111D & 00800N1D01N-06	35419 & 03	30MHz~1GHz	Apr. 28, 2021	Dec. 17, 2021~Dec. 20, 2021	Apr. 27, 2022	Radiation (03CH07-HY)
Double Ridge Horn Antenna	ESCO	3117	00075962	1GHz ~ 18GHz	Dec. 03, 2021	Dec. 17, 2021~Dec. 20, 2021	Dec. 02, 2022	Radiation (03CH07-HY)
Loop Antenna	Rohde & Schwarz	HFH2-Z2	100315	9 kHz~30 MHz	Jan. 04, 2021	Dec. 17, 2021~Dec. 20, 2021	Jan. 03, 2022	Radiation (03CH07-HY)
Preamplifier	MITEQ	AMF-7D-0010 1800-30-10P	1590075	1GHz~18GHz	Apr. 22, 2021	Dec. 17, 2021~Dec. 20, 2021	Apr. 21, 2022	Radiation (03CH07-HY)
Preamplifier	COM-POWER	PA-103A	161241	10MHz~1GHz	Oct. 04, 2021	Dec. 17, 2021~Dec. 20, 2021	Oct. 03, 2022	Radiation (03CH07-HY)
Preamplifier	Agilent	8449B	3008A02362	1GHz~26.5GHz	Oct. 04, 2021	Dec. 17, 2021~Dec. 20, 2021	Oct. 03, 2022	Radiation (03CH07-HY)
Preamplifier	EMEC	EM18G40G	0600789	18-40GHz	Jul. 23, 2021	Dec. 17, 2021~Dec. 20, 2021	Jul. 22, 2022	Radiation (03CH07-HY)
Spectrum Analyzer	Agilent	N9030A	MY52350276	3Hz~44GHz	Jul. 22, 2021	Dec. 17, 2021~Dec. 20, 2021	Jul. 21, 2022	Radiation (03CH07-HY)
RF Cable	HUBER + SUHNER	SUCOFLEX 104	MY15682-4	30MHz to 18GHz	Feb. 24, 2021	Dec. 17, 2021~Dec. 20, 2021	Feb. 23, 2022	Radiation (03CH07-HY)
RF Cable	HUBER + SUHNER	SUCOFLEX 104	MY24971-4	9kHz to 18GHz	Feb. 24, 2021	Dec. 17, 2021~Dec. 20, 2021	Feb. 23, 2022	Radiation (03CH07-HY)
RF Cable	HUBER + SUHNER	SUCOFLEX 104	MY28655-4	9kHz to 18GHz	Feb. 24, 2021	Dec. 17, 2021~Dec. 20, 2021	Feb. 23, 2022	Radiation (03CH07-HY)
RF Cable	HUBER + SUHNER	SUCOFLEX 102	MY2858/2,801 606/2	18GHz~ 40GHz	Feb. 24, 2021	Dec. 17, 2021~Dec. 20, 2021	Feb. 23, 2022	Radiation (03CH07-HY)
RF Cable	HUBER + SUHNER	SUCOFLEX 126	532078/126E	30MHz~ 18GHz	Sep. 17, 2021	Dec. 17, 2021~Dec. 20, 2021	Sep. 16, 2022	Radiation (03CH07-HY)
RF Cable	HUBER + SUHNER	SUCOFLEX 102	801606/2	9KHz ~ 40GHz	Apr. 03, 2021	Dec. 17, 2021~Dec. 20, 2021	Apr. 02, 2022	Radiation (03CH07-HY)
Controller	EMEC	EM1000	N/A	Control Ant Mast	N/A	Dec. 17, 2021~Dec. 20, 2021	N/A	Radiation (03CH07-HY)
Controller	MF	MF-7802	N/A	Control Turn table	N/A	Dec. 17, 2021~Dec. 20, 2021	N/A	Radiation (03CH07-HY)
Antenna Mast	EMEC	AM-BS-4500E	N/A	Boresight mast 1M~4M	N/A	Dec. 17, 2021~Dec. 20, 2021	N/A	Radiation (03CH07-HY)
Turn Table	ChainTek	Chaintek 3000	N/A	0~360 Degree	N/A	Dec. 17, 2021~Dec. 20, 2021	N/A	Radiation (03CH07-HY)
Software	Audix	E3	N/A	N/A	N/A	Dec. 17, 2021~Dec. 20, 2021	N/A	Radiation (03CH07-HY)
USB Data Logger	TECPEL	TR-32	HE17XB2495	N/A	Mar. 09, 2021	Dec. 17, 2021~Dec. 20, 2021	Mar. 08, 2022	Radiation (03CH07-HY)
SHF-EHF Horn Antenna	SCHWARZBECK	BBHA 9170	BBHA9170251	18GHz~ 40GHz	Nov. 30, 2021	Dec. 17, 2021~Dec. 20, 2021	Nov. 29, 2022	Radiation (03CH07-HY)



Instrument	Brand Name	Model No.	Serial No.	Characteristics	Calibration Date	Test Date	Due Date	Remark
AC Power Source	ChainTek	APC-1000W	N/A	N/A	N/A	Nov. 03, 2021	N/A	Conduction (CO05-HY)
EMI Test Receiver	Rohde & Schwarz	ESR3	102388	9kHz~3.6GHz	Nov. 30, 2020	Nov. 03, 2021	Nov. 29, 2021	Conduction (CO05-HY)
Hygrometer	Testo	608-H1	34913912	N/A	Nov. 18, 2020	Nov. 03, 2021	Nov. 17, 2021	Conduction (CO05-HY)
LISN	Rohde & Schwarz	ENV216	100080	9kHz~30MHz	Dec. 01, 2020	Nov. 03, 2021	Nov. 30, 2021	Conduction (CO05-HY)
Software	Rohde & Schwarz	EMC32 V10.30	N/A	N/A	N/A	Nov. 03, 2021	N/A	Conduction (CO05-HY)
Pulse Limiter	SCHWARZBECK	VTSD 9561-FN	00691	N/A	Jul. 28, 2021	Nov. 03, 2021	Jul. 27, 2022	Conduction (CO05-HY)
LISN Cable	MVE	RG-400	260260	N/A	Dec. 31, 2020	Nov. 03, 2021	Dec. 30, 2021	Conduction (CO05-HY)
Hygrometer	Testo	608-H1	34893241	N/A	Mar. 01, 2021	Nov. 09, 2021~Dec. 22, 2021	Feb. 28, 2022	Conducted (TH05-HY)
Power Sensor	DARE	RPR3006W #010	RPR6W-21010 02(NO:123)	10MHz~8GHz	Feb. 03, 2021	Nov. 09, 2021~Dec. 22, 2021	Feb. 02, 2022	Conducted (TH05-HY)
Signal Analyzer	Rohde & Schwarz	FSV40	101566	10Hz~40GHz	Aug. 30, 2021	Nov. 09, 2021~Dec. 22, 2021	Aug. 29, 2022	Conducted (TH05-HY)
Switch Box & RF Cable	EM Electronics	EMSW18SE	SW191204 (BOX8)	N/A	Jan. 07, 2021	Nov. 09, 2021~Dec. 22, 2021	Jan. 06, 2022	Conducted (TH05-HY)
Signal Generator (Interferer)	Rohde & Schwarz	SMW200A	109425	100kHz~7.5GHz	Jan. 13, 2022	Jan. 29, 2022	Jan. 12, 2023	CBP (DF02-HY)
Spectrum Analyzer	Rohde & Schwarz	FSV3044	101048	10Hz~44GHz	Apr. 20, 2021	Jan. 29, 2022	Apr. 19, 2022	CBP (DF02-HY)
Power Divider	Woken	2Way Divider	DCMB1KW7A1	0.5GHz-18GHz	Calibration from System	Jan. 29, 2022	Calibration from System	CBP (DF02-HY)
Power Divider	Woken	2Way Divider	DCMB1KW7A2	0.5GHz-18GHz	Calibration from System	Jan. 29, 2022	Calibration from System	CBP (DF02-HY)
Coupler	Woken	10dB 30W SMA	DOM5CIW3A1	0.5-18GHz	Calibration from System	Jan. 29, 2022	Calibration from System	CBP (DF02-HY)
Power Divider	Woken	3Way SMA Power Divder Rated to 20W	ST108-0010 (#2)	2GHz-8GHz	Calibration from System	Jan. 29, 2022	Calibration from System	CBP (DF02-HY)



5 Uncertainty of Evaluation

Uncertainty of Conducted Emission Measurement (150kHz ~ 30MHz)

Measuring Uncertainty for a Level of Confidence of 95% ($U = 2Uc(y)$)	3.1 dB
---	--------

Uncertainty of Radiated Emission Measurement (30 MHz ~ 1000 MHz)

Measuring Uncertainty for a Level of Confidence of 95% ($U = 2Uc(y)$)	5.1 dB
---	--------

Uncertainty of Radiated Emission Measurement (1000 MHz ~ 18000 MHz)

Measuring Uncertainty for a Level of Confidence of 95% ($U = 2Uc(y)$)	5.8 dB
---	--------

Uncertainty of Radiated Emission Measurement (18000 MHz ~ 40000 MHz)

Measuring Uncertainty for a Level of Confidence of 95% ($U = 2Uc(y)$)	4.0 dB
---	--------

Appendix A. Test Result of Conducted Test Items

Test Engineer:	Benny Ku/Shiming Liu	Temperature:	19.8~23.7	°C
Test Date:	2021/11/9~2021/12/22	Relative Humidity:	51.7~55.3	%

TEST RESULTS DATA
26dB and 99% OBW

Band V MIMO									
Mod.	Data Rate	NTX	CH.	Freq. (MHz)	99% Bandwidth (MHz)		26 dB Bandwidth (MHz)		Note
					Ant 3	Ant 4	Ant 3	Ant 4	
11a	6Mbps	2	001	5955	16.43	16.48	19.53	19.75	
11a	6Mbps	2	045	6175	16.43	16.43	19.43	19.48	
11a	6Mbps	2	093	6415	16.43	16.43	19.35	19.53	

TEST RESULTS DATA
EIRP Power Table

FCC Band V MIMO												
Mod.	Data Rate	NTX	CH.	Freq. (MHz)	Conducted Power (dBm)			DG (dBi)		EIRP Power (dBm)	EIRP Power Limit (dBm)	Pass /Fail
					Ant 3	Ant 4	SUM	Ant 3	Ant 4			
11a	6Mbps	2	001	5955	0.80	0.10	3.47	3.40		6.87	24.00	Pass
11a	6Mbps	2	045	6175	0.90	-0.20	3.40	3.40		6.80	24.00	Pass
11a	6Mbps	2	093	6415	0.70	-0.10	3.33	3.40		6.73	24.00	Pass

TEST RESULTS DATA
EIRP Power Spectral Density

FCC Band V MIMO												
Mod.	Data Rate	NTX	CH.	Freq. (MHz)	Conducted Power Density (dBm/MHz)			DG (dBi)		EIRP Power Density (dBm/MHz)	EIRP Power Density Limit (dBm)	Pass /Fail
					Ant 3	Ant 4	SUM	Ant 3	Ant 4	SUM		
11a	6Mbps	2	001	5955			-6.98	5.53		-1.45	-1.00	Pass
11a	6Mbps	2	045	6175			-7.00	5.53		-1.47	-1.00	Pass
11a	6Mbps	2	093	6415			-6.81	5.53		-1.28	-1.00	Pass

TEST RESULTS DATA
26dB and 99% OBW

Band VI MIMO									
Mod.	Data Rate	NTX	CH.	Freq. (MHz)	99% Bandwidth (MHz)		26 dB Bandwidth (MHz)		Note
					Ant 3	Ant 4	Ant 3	Ant 4	
11a	6Mbps	2	097	6435	16.43	16.43	19.48	19.60	
11a	6Mbps	2	105	6475	16.43	16.43	19.43	19.63	
11a	6Mbps	2	113	6515	16.43	16.43	19.43	19.63	

TEST RESULTS DATA
EIRP Power Table

FCC Band VI MIMO												
Mod.	Data Rate	NTX	CH.	Freq. (MHz)	Conducted Power (dBm)			DG (dBi)		EIRP Power (dBm)	EIRP Power Limit (dBm)	Pass /Fail
					Ant 3	Ant 4	SUM	Ant 3	Ant 4	SUM		
11a	6Mbps	2	097	6435	-1.00	-1.50	1.77	3.40		5.17	24.00	Pass
11a	6Mbps	2	105	6475	-1.20	-2.10	1.38	3.40		4.78	24.00	Pass
11a	6Mbps	2	113	6515	-1.30	-2.10	1.33	3.40		4.73	24.00	Pass

TEST RESULTS DATA
EIRP Power Spectral Density

FCC Band VI MIMO												
Mod.	Data Rate	NTX	CH.	Freq. (MHz)	Conducted Power Density (dBm/MHz)			DG (dBi)		EIRP Power Density (dBm/MHz)	EIRP Power Density Limit (dBm)	Pass /Fail
					Ant 3	Ant 4	SUM	Ant 3	Ant 4	SUM		
11a	6Mbps	2	097	6435			-8.25	5.53	-2.72	-1.00	Pass	
11a	6Mbps	2	105	6475			-8.50	5.53	-2.97	-1.00	Pass	
11a	6Mbps	2	113	6515			-8.37	5.53	-2.84	-1.00	Pass	

TEST RESULTS DATA
26dB and 99% OBW

Band VII MIMO									
Mod.	Data Rate	NTX	CH.	Freq. (MHz)	99% Bandwidth (MHz)		26 dB Bandwidth (MHz)		Note
					Ant 3	Ant 4	Ant 3	Ant 4	
11a	6Mbps	2	117	6535	16.43	16.43	19.48	19.58	
11a	6Mbps	2	149	6695	16.43	16.43	19.55	19.65	
11a	6Mbps	2	181	6855	16.43	16.43	19.40	19.60	

TEST RESULTS DATA
EIRP Power Table

FCC Band VII MIMO												
Mod.	Data Rate	NTX	CH.	Freq. (MHz)	Conducted Power (dBm)			DG (dBi)		EIRP Power (dBm)	EIRP Power Limit (dBm)	Pass /Fail
					Ant 3	Ant 4	SUM	Ant 3	Ant 4			
11a	6Mbps	2	117	6535	-1.00	-1.90	1.58	3.40		4.98	24.00	Pass
11a	6Mbps	2	149	6695	-1.30	-1.90	1.42	3.40		4.82	24.00	Pass
11a	6Mbps	2	181	6855	-1.10	-1.80	1.57	3.40		4.97	24.00	Pass

TEST RESULTS DATA
EIRP Power Spectral Density

FCC Band VII MIMO												
Mod.	Data Rate	NTX	CH.	Freq. (MHz)	Conducted Power Density (dBm/MHz)			DG (dBi)		EIRP Power Density (dBm/MHz)	EIRP Power Density Limit (dBm)	Pass /Fail
					Ant 3	Ant 4	SUM	Ant 3	Ant 4	SUM		
11a	6Mbps	2	117	6535			-8.34	5.53	-2.81	-1.00	Pass	
11a	6Mbps	2	149	6695			-8.63	5.53	-3.10	-1.00	Pass	
11a	6Mbps	2	181	6855			-8.69	5.53	-3.16	-1.00	Pass	

TEST RESULTS DATA
26dB EBW and 99% OBW

Band VII straddle channel MIMO									
Mod.	Data Rate	NTX	CH.	Freq. (MHz)	99% Bandwidth (MHz)		26 dB Bandwidth (MHz)		Note
					Ant 3	Ant 4	Ant 3	Ant 4	
11a	6Mbps	2	185	6875	16.43	16.43	19.45	19.60	

Band VIII MIMO									
Mod.	Data Rate	NTX	CH.	Freq. (MHz)	99% Bandwidth (MHz)		26 dB Bandwidth (MHz)		Note
					Ant 3	Ant 4	Ant 3	Ant 4	
11a	6Mbps	2	209	6995	16.48	16.43	19.30	19.35	
11a	6Mbps	2	233	7115	16.38	16.43	19.45	19.63	

TEST RESULTS DATA
EIRP Power Table

FCC Band VII straddle channel MIMO												
Mod.	Data Rate	NTX	CH.	Freq. (MHz)	Conducted Power (dBm)			DG (dBi)		EIRP Power (dBm)	EIRP Power Limit (dBm)	Pass /Fail
					Ant 3	Ant 4	SUM	Ant 3	Ant 4			
11a	6Mbps	2	185	6875	-0.40	-0.90	2.37	3.40		5.77	24.00	Pass

FCC Band VIII MIMO												
Mod.	Data Rate	NTX	CH.	Freq. (MHz)	Conducted Power (dBm)			DG (dBi)		EIRP Power (dBm)	EIRP Power Limit (dBm)	Pass /Fail
					Ant 3	Ant 4	SUM	Ant 3	Ant 4			
11a	6Mbps	2	209	6995	-0.50	-0.90	2.31	3.40		5.71	24.00	Pass
11a	6Mbps	2	233	7115	-8.80	-9.50	-6.13	3.40		-2.73	24.00	Pass

TEST RESULTS DATA
EIRP Power Spectral Density

FCC Band VII straddle channel MIMO											
Mod.	Data Rate	NTX	Freq. (MHz)	Conducted Power Density (dBm/MHz)			DG (dBi)		EIRP Power Density (dBm/MHz)	EIRP Power Density Limit (dBm)	Pass /Fail
				Ant 3	Ant 4	SUM	Ant 3	Ant 4	SUM		
11a	6Mbps	2	6875			-7.80	5.53	-2.27	-1.00	Pass	

FCC Band VIII MIMO											
Mod.	Data Rate	NTX	Freq. (MHz)	Conducted Power Density (dBm/MHz)			DG (dBi)		EIRP Power Density (dBm/MHz)	EIRP Power Density Limit (dBm)	Pass /Fail
				Ant 3	Ant 4	SUM	Ant 3	Ant 4	SUM		
11a	6Mbps	2	6995			-7.80	5.53	-2.27	-1.00	Pass	
11a	6Mbps	2	7115			-15.85	5.53	-10.32	-1.00	Pass	

TEST RESULTS DATA
26dB and 99% OBW

Band V MIMO									
Mod.	Data Rate	NTX	Freq. (MHz)	RU Config	99% Bandwidth (MHz)		26 dB Bandwidth (MHz)		Note
					Ant 3	Ant 4	Ant 3	Ant 4	
HE20	MCS0	2	5955	Full	18.93	18.93	21.13	21.50	
HE20	MCS0	2	6175	Full	18.93	18.93	21.25	21.28	
HE20	MCS0	2	6415	Full	18.93	18.93	21.25	21.30	
HE40	MCS0	2	5965	Full	37.96	37.96	40.41	40.23	
HE40	MCS0	2	6165	Full	37.96	37.96	40.14	40.19	
HE40	MCS0	2	6405	Full	37.96	38.06	40.28	40.28	
HE80	MCS0	2	5985	Full	77.20	77.20	83.12	84.24	
HE80	MCS0	2	6145	Full	77.20	77.08	83.12	83.12	
HE80	MCS0	2	6385	Full	77.32	77.20	82.96	83.28	
HE160	MCS0	2	6025	Full	156.32	156.32	165.44	166.24	
HE160	MCS0	2	6185	Full	156.08	156.08	165.28	164.96	
HE160	MCS0	2	6345	Full	156.32	156.08	164.96	165.12	

TEST RESULTS DATA
EIRP Power Table

FCC Band V MIMO												
Mod.	Data Rate	NTX	Freq. (MHz)	RU Config	Conducted Power (dBm)			DG (dBi)		EIRP Power (dBm)	EIRP Power Limit (dBm)	Pass /Fail
					Ant 3	Ant 4	SUM	Ant 3	Ant 4			
HE20	MCS0	2	5955	Full	1.00	0.50	3.77	3.40		7.17	24.00	Pass
HE20	MCS0	2	6175	Full	0.90	0.10	3.53	3.40		6.93	24.00	Pass
HE20	MCS0	2	6415	Full	0.80	0.10	3.47	3.40		6.87	24.00	Pass
HE40	MCS0	2	5965	Full	3.50	3.00	6.27	3.40		9.67	24.00	Pass
HE40	MCS0	2	6165	Full	3.60	2.70	6.18	3.40		9.58	24.00	Pass
HE40	MCS0	2	6405	Full	3.60	3.00	6.32	3.40		9.72	24.00	Pass
HE80	MCS0	2	5985	Full	7.00	6.20	9.63	3.40		13.03	24.00	Pass
HE80	MCS0	2	6145	Full	7.00	5.80	9.45	3.40		12.85	24.00	Pass
HE80	MCS0	2	6385	Full	6.60	5.90	9.27	3.40		12.67	24.00	Pass
HE160	MCS0	2	6025	Full	9.40	8.70	12.07	3.40		15.47	24.00	Pass
HE160	MCS0	2	6185	Full	9.40	8.30	11.90	3.40		15.30	24.00	Pass
HE160	MCS0	2	6345	Full	9.30	8.30	11.84	3.40		15.24	24.00	Pass

TEST RESULTS DATA
EIRP Power Spectral Density

FCC Band V MIMO												
Mod.	Data Rate	NTX	Freq. (MHz)	RU Config	Conducted Power Density (dBm/MHz)			DG (dBi)		EIRP Power Density (dBm/MHz)	EIRP Power Density Limit (dBm)	Pass /Fail
					Ant 3	Ant 4	SUM	Ant 3	Ant 4	SUM		
HE20	MCS0	2	5955	Full			-6.85	5.53		-1.32	-1.00	Pass
HE20	MCS0	2	6175	Full			-6.90	5.53		-1.37	-1.00	Pass
HE20	MCS0	2	6415	Full			-6.92	5.53		-1.39	-1.00	Pass
HE40	MCS0	2	5965	Full			-6.97	5.53		-1.44	-1.00	Pass
HE40	MCS0	2	6165	Full			-7.19	5.53		-1.66	-1.00	Pass
HE40	MCS0	2	6405	Full			-6.80	5.53		-1.27	-1.00	Pass
HE80	MCS0	2	5985	Full			-6.79	5.53		-1.26	-1.00	Pass
HE80	MCS0	2	6145	Full			-6.80	5.53		-1.27	-1.00	Pass
HE80	MCS0	2	6385	Full			-7.08	5.53		-1.55	-1.00	Pass
HE160	MCS0	2	6025	Full			-6.98	5.53		-1.45	-1.00	Pass
HE160	MCS0	2	6185	Full			-6.96	5.53		-1.43	-1.00	Pass
HE160	MCS0	2	6345	Full			-7.09	5.53		-1.56	-1.00	Pass

TEST RESULTS DATA
26dB and 99% OBW

Band VI MIMO									
Mod.	Data Rate	NTX	Freq. (MHz)	RU Config	99% Bandwidth (MHz)		26 dB Bandwidth (MHz)		Note
					Ant 3	Ant 4	Ant 3	Ant 4	
HE20	MCS0	2	6435	Full	18.93	18.93	21.25	21.33	
HE20	MCS0	2	6475	Full	18.93	18.93	21.40	21.50	
HE20	MCS0	2	6515	Full	18.93	18.93	21.18	21.28	
HE40	MCS0	2	6445	Full	37.96	38.06	40.37	40.28	
HE40	MCS0	2	6485	Full	38.06	37.96	40.37	40.32	
HE80	MCS0	2	6465	Full	77.20	77.32	83.60	83.20	

Band VI straddle channel MIMO									
Mod.	Data Rate	NTX	Freq. (MHz)	RU Config	99% Bandwidth (MHz)		26 dB Bandwidth (MHz)		Note
					Ant 3	Ant 4	Ant 3	Ant 4	
HE40	MCS0	2	6525	Full	37.86	37.86	40.55	40.10	
HE80	MCS0	2	6545	Full	77.20	77.08	82.47	82.24	
HE160	MCS0	2	6505	Full	156.08	156.08	165.60	165.76	

TEST RESULTS DATA
EIRP Power Table

FCC Band VI MIMO												
Mod.	Data Rate	NTX	Freq. (MHz)	RU Config	Conducted Power (dBm)			DG (dBi)		EIRP Power (dBm)	EIRP Power Limit (dBm)	Pass /Fail
					Ant 3	Ant 4	SUM	Ant 3	Ant 4			
HE20	MCS0	2	6435	Full	-0.80	-1.10	2.06	3.40		5.46	24.00	Pass
HE20	MCS0	2	6475	Full	-1.00	-1.80	1.63	3.40		5.03	24.00	Pass
HE20	MCS0	2	6515	Full	-1.00	-1.70	1.67	3.40		5.07	24.00	Pass
HE40	MCS0	2	6445	Full	2.00	1.30	4.67	3.40		8.07	24.00	Pass
HE40	MCS0	2	6485	Full	2.00	1.60	4.81	3.40		8.21	24.00	Pass
HE80	MCS0	2	6465	Full	5.00	4.40	7.72	3.40		11.12	24.00	Pass

FCC Band VI straddle channel MIMO												
Mod.	Data Rate	NTX	Freq. (MHz)	RU Config	Conducted Power (dBm)			DG (dBi)		EIRP Power (dBm)	EIRP Power Limit (dBm)	Pass /Fail
					Ant 3	Ant 4	SUM	Ant 3	Ant 4			
HE40	MCS0	2	6525	Full	2.50	1.40	5.00	3.40		8.40	24.00	Pass
HE80	MCS0	2	6545	Full	4.90	4.20	7.57	3.40		10.97	24.00	Pass
HE160	MCS0	2	6505	Full	8.30	7.50	10.93	3.40		14.33	24.00	Pass

TEST RESULTS DATA
EIRP Power Spectral Density

Band VI MIMO												
Mod.	Data Rate	NTX	Freq. (MHz)	RU Config	Conducted Power Density (dBm/MHz)			DG (dBi)		EIRP Power Density (dBm/MHz)	EIRP Power Density Limit (dBm)	Pass /Fail
					Ant 3	Ant 4	SUM	Ant 3	Ant 4			
HE20	MCS0	2	6435	Full			-8.35	5.53	-2.82	-1.00	Pass	
HE20	MCS0	2	6475	Full			-8.48	5.53	-2.95	-1.00	Pass	
HE20	MCS0	2	6515	Full			-8.35	5.53	-2.82	-1.00	Pass	
HE40	MCS0	2	6445	Full			-8.45	5.53	-2.92	-1.00	Pass	
HE40	MCS0	2	6485	Full			-8.53	5.53	-3.00	-1.00	Pass	
HE80	MCS0	2	6465	Full			-8.22	5.53	-2.69	-1.00	Pass	

FCC Band VI straddle channel MIMO												
Mod.	Data Rate	NTX	Freq. (MHz)	RU Config	Conducted Power Density (dBm/MHz)			DG (dBi)		EIRP Power Density (dBm/MHz)	EIRP Power Density Limit (dBm)	Pass /Fail
					Ant 3	Ant 4	SUM	Ant 3	Ant 4			
HE40	MCS0	2	6525	Full			-8.28	5.53	-2.75	-1.00	Pass	
HE80	MCS0	2	6545	Full			-8.60	5.53	-3.07	-1.00	Pass	
HE160	MCS0	2	6505	Full			-8.18	5.53	-2.65	-1.00	Pass	

TEST RESULTS DATA
26dB and 99% OBW

Band VII MIMO									
Mod.	Data Rate	NTX	Freq. (MHz)	RU Config	99% Bandwidth (MHz)		26 dB Bandwidth (MHz)		Note
					Ant 3	Ant 4	Ant 3	Ant 4	
HE20	MCS0	2	6535	Full	18.93	18.93	21.48	21.33	
HE20	MCS0	2	6695	Full	18.93	18.93	21.15	21.43	
HE20	MCS0	2	6855	Full	18.93	18.98	21.15	21.50	
HE40	MCS0	2	6565	Full	37.96	37.96	40.32	40.59	
HE40	MCS0	2	6685	Full	38.06	37.96	40.32	40.41	
HE40	MCS0	2	6845	Full	37.86	37.96	40.23	40.28	
HE80	MCS0	2	6625	Full	77.20	77.20	81.76	82.64	
HE80	MCS0	2	6785	Full	77.32	77.20	81.83	82.32	
HE160	MCS0	2	6665	Full	156.08	156.08	165.28	165.60	

Band VII straddle channel MIMO									
Mod.	Data Rate	NTX	Freq. (MHz)	RU Config	99% Bandwidth (MHz)		26 dB Bandwidth (MHz)		Note
					Ant 3	Ant 4	Ant 3	Ant 4	
HE80	MCS0	2	6865	Full	77.20	77.32	82.20	82.04	
HE160	MCS0	2	6825	Full	156.08	156.08	165.92	164.32	

TEST RESULTS DATA
EIRP Power Table

FCC Band VII MIMO												
Mod.	Data Rate	NTX	Freq. (MHz)	RU Config	Conducted Power (dBm)			DG (dBi)		EIRP Power (dBm)	EIRP Power Limit (dBm)	Pass /Fail
					Ant 3	Ant 4	SUM	Ant 3	Ant 4			
HE20	MCS0	2	6535	Full	-0.70	-1.50	1.93	3.40		5.33	24.00	Pass
HE20	MCS0	2	6695	Full	-1.00	-1.60	1.72	3.40		5.12	24.00	Pass
HE20	MCS0	2	6855	Full	-0.90	-1.60	1.77	3.40		5.17	24.00	Pass
HE40	MCS0	2	6565	Full	2.10	1.40	4.77	3.40		8.17	24.00	Pass
HE40	MCS0	2	6685	Full	1.80	1.30	4.57	3.40		7.97	24.00	Pass
HE40	MCS0	2	6845	Full	2.50	1.40	5.00	3.40		8.40	24.00	Pass
HE80	MCS0	2	6625	Full	5.00	4.20	7.63	3.40		11.03	24.00	Pass
HE80	MCS0	2	6785	Full	5.00	4.10	7.58	3.40		10.98	24.00	Pass
HE160	MCS0	2	6665	Full	7.80	7.40	10.61	3.40		14.01	24.00	Pass

FCC Band VII straddle channel MIMO												
Mod.	Data Rate	NTX	Freq. (MHz)	RU Config	Conducted Power (dBm)			DG (dBi)		EIRP Power (dBm)	EIRP Power Limit (dBm)	Pass /Fail
					Ant 3	Ant 4	SUM	Ant 3	Ant 4			
HE80	MCS0	2	6865	Full	5.10	4.30	7.73	3.40		11.13	24.00	Pass
HE160	MCS0	2	6825	Full	8.00	7.50	10.77	3.40		14.17	24.00	Pass

TEST RESULTS DATA
EIRP Power Spectral Density

FCC Band VII MIMO												
Mod.	Data Rate	NTX	Freq. (MHz)	RU Config	Conducted Power Density (dBm/MHz)			DG (dBi)		EIRP Power Density (dBm/MHz)	EIRP Power Density Limit (dBm)	Pass /Fail
					Ant 3	Ant 4	SUM	Ant 3	Ant 4	SUM		
HE20	MCS0	2	6535	Full			-8.32	5.53	-2.79	-1.00	Pass	
HE20	MCS0	2	6695	Full			-8.62	5.53	-3.09	-1.00	Pass	
HE20	MCS0	2	6855	Full			-8.62	5.53	-3.09	-1.00	Pass	
HE40	MCS0	2	6565	Full			-8.60	5.53	-3.07	-1.00	Pass	
HE40	MCS0	2	6685	Full			-8.74	5.53	-3.21	-1.00	Pass	
HE40	MCS0	2	6845	Full			-8.52	5.53	-2.99	-1.00	Pass	
HE80	MCS0	2	6625	Full			-8.39	5.53	-2.86	-1.00	Pass	
HE80	MCS0	2	6785	Full			-8.35	5.53	-2.82	-1.00	Pass	
HE160	MCS0	2	6665	Full			-8.63	5.53	-3.10	-1.00	Pass	

FCC Band VII straddle channel MIMO												
Mod.	Data Rate	NTX	Freq. (MHz)	RU Config	Conducted Power Density (dBm/MHz)			DG (dBi)		EIRP Power Density (dBm/MHz)	EIRP Power Density Limit (dBm)	Pass /Fail
					Ant 3	Ant 4	SUM	Ant 3	Ant 4	SUM		
HE80	MCS0	2	6865	Full			-8.67	5.53	-3.14	-1.00	Pass	
HE160	MCS0	2	6825	Full			-8.44	5.53	-2.91	-1.00	Pass	

TEST RESULTS DATA
26dB EBW and 99% OBW

Band VII straddle channel MIMO									
Mod.	Data Rate	NTX	Freq. (MHz)	RU Config	99% Bandwidth (MHz)		26 dB Bandwidth (MHz)		Note
					Ant 3	Ant 4	Ant 3	Ant 4	
HE20	MCS0	2	6875	Full	18.93	18.93	21.33	21.53	
HE40	MCS0	2	6885	Full	37.96	37.96	40.28	40.05	

Band VIII MIMO									
Mod.	Data Rate	NTX	Freq. (MHz)	RU Config	99% Bandwidth (MHz)		26 dB Bandwidth (MHz)		Note
					Ant 3	Ant 4	Ant 3	Ant 4	
HE20	MCS0	2	6995	Full	18.98	18.93	21.43	21.05	
HE20	MCS0	2	7115	Full	18.93	18.98	21.38	21.48	
HE40	MCS0	2	6965	Full	37.86	37.86	40.19	40.05	
HE40	MCS0	2	7085	Full	37.96	37.86	40.37	40.14	
HE80	MCS0	2	6945	Full	77.08	77.32	82.46	81.99	
HE80	MCS0	2	7025	Full	77.20	77.32	82.06	82.06	
HE160	MCS0	2	6985	Full	156.08	156.32	165.76	165.12	

TEST RESULTS DATA
EIRP Power Table

FCC Band VII straddle channel MIMO												
Mod.	Data Rate	NTX	Freq. (MHz)	RU Config	Conducted Power (dBm)			DG (dBi)		EIRP Power (dBm)	EIRP Power Limit (dBm)	Pass /Fail
					Ant 3	Ant 4	SUM	Ant 3	Ant 4			
HE20	MCS0	2	6875	Full	-0.20	-0.60	2.61	3.40		6.01	24.00	Pass
HE40	MCS0	2	6885	Full	2.90	2.10	5.53	3.40		8.93	24.00	Pass

Band VIII MIMO												
Mod.	Data Rate	NTX	Freq. (MHz)	RU Config	Conducted Power (dBm)			DG (dBi)		EIRP Power (dBm)	EIRP Power Limit (dBm)	Pass /Fail
					Ant 3	Ant 4	SUM	Ant 3	Ant 4			
HE20	MCS0	2	6995	Full	-0.20	-0.70	2.57	3.40		5.97	24.00	Pass
HE20	MCS0	2	7115	Full	-8.70	-9.50	-6.07	3.40		-2.67	24.00	Pass
HE40	MCS0	2	6965	Full	3.40	2.70	6.07	3.40		9.47	24.00	Pass
HE40	MCS0	2	7085	Full	3.00	2.20	5.63	3.40		9.03	24.00	Pass
HE80	MCS0	2	6945	Full	6.20	5.50	8.87	3.40		12.27	24.00	Pass
HE80	MCS0	2	7025	Full	6.20	6.00	9.11	3.40		12.51	24.00	Pass
HE160	MCS0	2	6985	Full	8.90	8.50	11.71	3.40		15.11	24.00	Pass

TEST RESULTS DATA
EIRP Power Spectral Density

FCC Band VII straddle channel MIMO												
Mod.	Data Rate	NTX	Freq. (MHz)	RU Config	Conducted Power Density (dBm/MHz)			DG (dBi)		EIRP Power Density (dBm/MHz)	EIRP Power Density Limit (dBm)	Pass /Fail
					Ant 3	Ant 4	SUM	Ant 3	Ant 4	SUM		
HE20	MCS0	2	6875	Full			-7.64	5.53	-2.11	-1.00	Pass	
HE40	MCS0	2	6885	Full			-7.61	5.53	-2.08	-1.00	Pass	

FCC Band VIII MIMO												
Mod.	Data Rate	NTX	Freq. (MHz)	RU Config	Conducted Power Density (dBm/MHz)			DG (dBi)		EIRP Power Density (dBm/MHz)	EIRP Power Density Limit (dBm)	Pass /Fail
					Ant 3	Ant 4	SUM	Ant 3	Ant 4	SUM		
HE20	MCS0	2	6995	Full			-7.87	5.53	-2.34	-1.00	Pass	
HE20	MCS0	2	7115	Full			-15.82	5.53	-10.29	-1.00	Pass	
HE40	MCS0	2	6965	Full			-7.55	5.53	-2.02	-1.00	Pass	
HE40	MCS0	2	7085	Full			-7.74	5.53	-2.21	-1.00	Pass	
HE80	MCS0	2	6945	Full			-7.61	5.53	-2.08	-1.00	Pass	
HE80	MCS0	2	7025	Full			-7.57	5.53	-2.04	-1.00	Pass	
HE160	MCS0	2	6985	Full			-7.63	5.53	-2.10	-1.00	Pass	



Appendix B. AC Conducted Emission Test Results

Test Engineer :	Calivn Wang	Temperature :	23~26°C
		Relative Humidity :	45~55%

EUT Information

Report NO : 190614
 Test Mode : Mode 1
 Test Voltage : 120Vac/60Hz
 Phase : Line

Full Spectrum

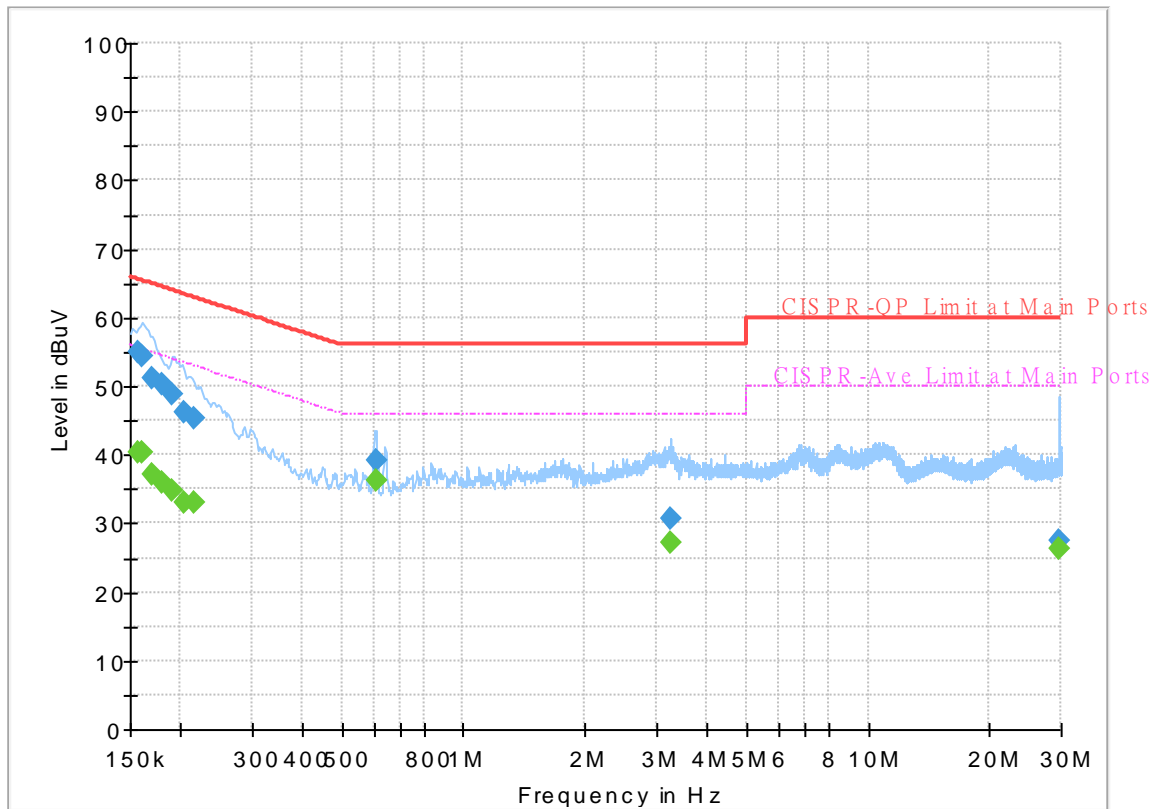

Final_Result

Frequency (MHz)	QuasiPeak (dBuV)	CAverage (dBuV)	Limit (dBuV)	Margin (dB)	Line	Filter	Corr. (dB)
0.156750	54.86	---	65.63	10.77	L1	OFF	19.7
0.156750	---	40.40	55.63	15.23	L1	OFF	19.7
0.161250	54.53	---	65.40	10.87	L1	OFF	19.7
0.161250	---	40.46	55.40	14.94	L1	OFF	19.7
0.170250	51.23	---	64.95	13.72	L1	OFF	19.7
0.170250	---	37.11	54.95	17.84	L1	OFF	19.7
0.179250	50.18	---	64.52	14.34	L1	OFF	19.7
0.179250	---	35.85	54.52	18.67	L1	OFF	19.7
0.190500	48.78	---	64.02	15.24	L1	OFF	19.7
0.190500	---	34.94	54.02	19.08	L1	OFF	19.7
0.204000	46.26	---	63.45	17.19	L1	OFF	19.7
0.204000	---	33.13	53.45	20.32	L1	OFF	19.7
0.215250	45.25	---	63.00	17.75	L1	OFF	19.7
0.215250	---	33.07	53.00	19.93	L1	OFF	19.7
0.606750	39.11	---	56.00	16.89	L1	OFF	19.9
0.606750	---	36.19	46.00	9.81	L1	OFF	19.9
3.246000	30.77	---	56.00	25.23	L1	OFF	20.0
3.246000	---	27.16	46.00	18.84	L1	OFF	20.0
29.564250	27.35	---	60.00	32.65	L1	OFF	20.7
29.564250	---	26.27	50.00	23.73	L1	OFF	20.7

EUT Information

Report NO : 190614
 Test Mode : Mode 1
 Test Voltage : 120Vac/60Hz
 Phase : Neutral

Full Spectrum

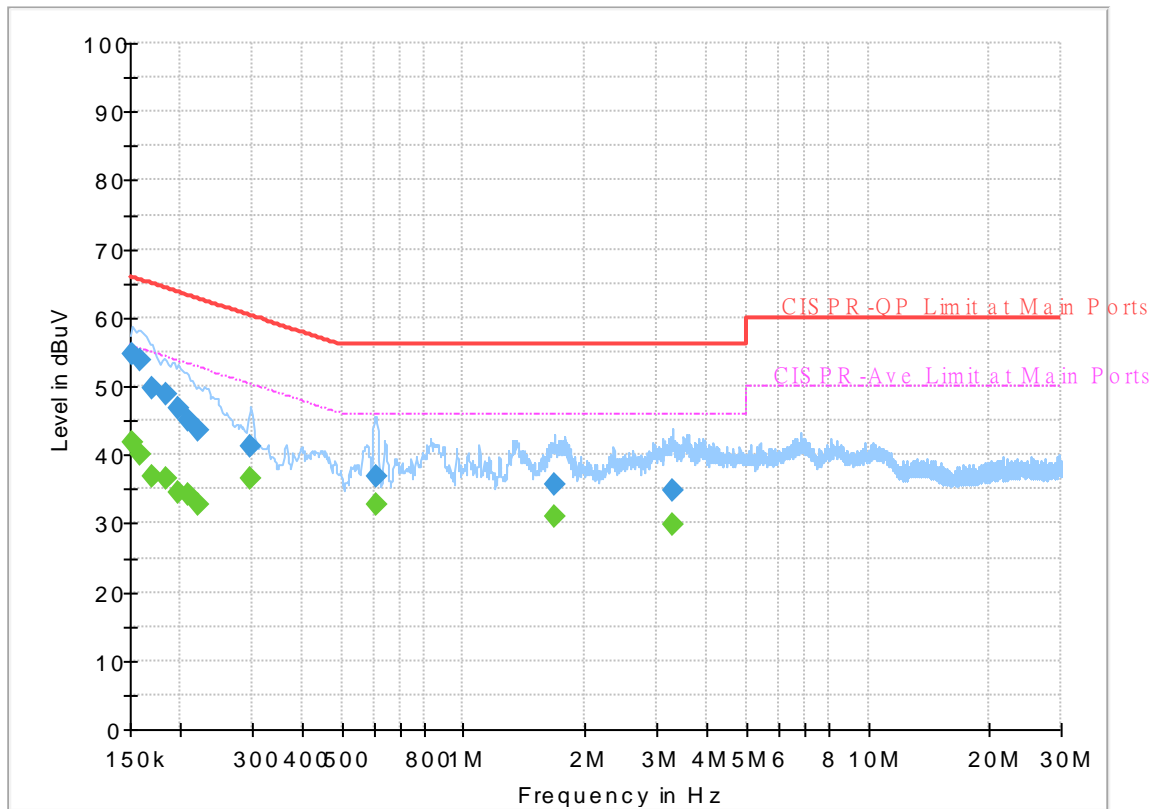

Final Result

Frequency (MHz)	QuasiPeak (dBuV)	CAverage (dBuV)	Limit (dBuV)	Margin (dB)	Line	Filter	Corr. (dB)
0.152250	---	41.89	55.88	13.99	N	OFF	19.7
0.152250	54.75	---	65.88	11.13	N	OFF	19.7
0.159000	---	40.14	55.52	15.38	N	OFF	19.7
0.159000	53.86	---	65.52	11.66	N	OFF	19.7
0.170250	---	36.96	54.95	17.99	N	OFF	19.7
0.170250	49.78	---	64.95	15.17	N	OFF	19.7
0.183750	---	36.59	54.31	17.72	N	OFF	19.7
0.183750	48.84	---	64.31	15.47	N	OFF	19.7
0.197250	---	34.56	53.73	19.17	N	OFF	19.7
0.197250	46.82	---	63.73	16.91	N	OFF	19.7
0.208500	---	34.21	53.27	19.06	N	OFF	19.7
0.208500	45.13	---	63.27	18.14	N	OFF	19.7
0.222000	---	32.65	52.74	20.09	N	OFF	19.7
0.222000	43.54	---	62.74	19.20	N	OFF	19.7
0.298500	---	36.50	50.28	13.78	N	OFF	19.7
0.298500	41.27	---	60.28	19.01	N	OFF	19.7
0.611250	---	32.83	46.00	13.17	N	OFF	19.9
0.611250	36.98	---	56.00	19.02	N	OFF	19.9
1.682250	---	30.99	46.00	15.01	N	OFF	20.2
1.682250	35.69	---	56.00	20.31	N	OFF	20.2
3.295500	---	29.95	46.00	16.05	N	OFF	20.0

3.295500	34.72	---	56.00	21.28	N	OFF	20.0
----------	-------	-----	-------	-------	---	-----	------



Appendix C. Radiated Spurious Emission

Test Engineer :	Jesse Wang, Stan Hsieh and Ken Wu	Temperature :	23.1~25.3°C
		Relative Humidity :	53.6~59.1%

Band 5 - 5925~6425MHz

WIFI 802.11ax HE20 Full (Band Edge @ 3m)

WIFI Ant.	Note	Frequency (MHz)	Level (dBμV/m)	Over Limit (dB)	Limit Line (dBμV/m)	Read Level (dBμV)	Antenna Factor (dB/m)	Path Loss (dB)	Preamp Factor (dB)	Ant Pos (cm)	Table Pos (deg)	Peak Avg. (P/A)	Pol. (H/V)	
802.11ax HE20 Full CH 01 5955MHz		5892.06	50.32	-37.88	88.2	38	34.97	12.54	35.19	246	175	P	H	
		5920.76	40.98	-27.22	68.2	28.58	35.04	12.56	35.2	246	175	A	H	
	*	5955	96	-	-	83.51	35.11	12.58	35.2	246	175	P	H	
	*	5955	88.24	-	-	75.75	35.11	12.58	35.2	246	175	A	H	
													H	
														H
			5852.3	49.56	-38.64	88.2	37.42	34.81	12.51	35.18	100	67	P	V
			5924.4	41.01	-27.19	68.2	28.6	35.05	12.56	35.2	100	67	A	V
		*	5955	97.86	-	-	85.37	35.11	12.58	35.2	100	67	P	V
		*	5955	89.42	-	-	76.93	35.11	12.58	35.2	100	67	A	V
													V	
													V	
Remark	1. No other spurious found. 2. All results are PASS against Peak and Average limit line.													



Band 5 5925~6425MHz
WIFI 802.11ax HE40 Full (Band Edge @ 3m)

WIFI Ant. 3+4	Note	Frequency (MHz)	Level (dBμV/m)	Over Limit (dB)	Limit Line (dBμV/m)	Read Level (dBμV)	Antenna Factor (dB/m)	Path Loss (dB)	Preamp Factor (dB)	Ant Pos (cm)	Table Pos (deg)	Peak Avg. (P/A)	Pol. (H/V)	
802.11ax HE40 Full CH 03 5965MHz		5925	51.49	-36.71	88.2	39.08	35.05	12.56	35.2	250	174	P	H	
		5925	41.09	-27.11	68.2	28.68	35.05	12.56	35.2	250	174	A	H	
	*	5965	96.98	-	-	84.47	35.13	12.59	35.21	250	174	P	H	
	*	5965	88.31	-	-	75.8	35.13	12.59	35.21	250	174	A	H	
													H	
														H
			5895.54	50.55	-37.65	88.2	38.22	34.98	12.54	35.19	250	43	P	V
			5925	41.1	-27.1	68.2	28.69	35.05	12.56	35.2	250	43	A	V
		*	5965	95.77	-	-	83.26	35.13	12.59	35.21	250	43	P	V
		*	5965	88.35	-	-	75.84	35.13	12.59	35.21	250	43	A	V
													V	
													V	
Remark	1. No other spurious found. 2. All results are PASS against Peak and Average limit line.													



Band 5 5925~6425MHz
WIFI 802.11ax HE80 Full (Band Edge @ 3m)

WIFI Ant. 3+4	Note	Frequency (MHz)	Level (dBμV/m)	Over Limit (dB)	Limit Line (dBμV/m)	Read Level (dBμV)	Antenna Factor (dB/m)	Path Loss (dB)	Preamp Factor (dB)	Ant Pos (cm)	Table Pos (deg)	Peak Avg. (P/A)	Pol. (H/V)	
802.11ax HE80 Full CH 07 5985MHz		5912.36	50.85	-37.35	88.2	38.48	35.02	12.55	35.2	268	173	P	H	
		5919.4	41.27	-26.93	68.2	28.87	35.04	12.56	35.2	268	173	A	H	
	*	5985	96.45	-	-	83.89	35.17	12.6	35.21	268	173	P	H	
	*	5985	88.61	-	-	76.05	35.17	12.6	35.21	268	173	A	H	
													H	
														H
			5901.64	50.55	-37.65	88.2	38.19	35	12.55	35.19	268	58	P	V
			5922.44	41.33	-26.87	68.2	28.93	35.04	12.56	35.2	268	58	A	V
		*	5985	97.26	-	-	84.7	35.17	12.6	35.21	268	58	P	V
		*	5985	90.12	-	-	77.56	35.17	12.6	35.21	268	58	A	V
													V	
													V	
Remark	1. No other spurious found. 2. All results are PASS against Peak and Average limit line.													



Band 5 5925~6425MHz

WIFI 802.11ax HE160 Full (Band Edge @ 3m)

WIFI Ant. 3+4	Note	Frequency (MHz)	Level (dBμV/m)	Over Limit (dB)	Limit Line (dBμV/m)	Read Level (dBμV)	Antenna Factor (dB/m)	Path Loss (dB)	Preamp Factor (dB)	Ant Pos (cm)	Table Pos (deg)	Peak Avg. (P/A)	Pol. (H/V)	
802.11ax HE160 Full CH 15 6025MHz		5833	50.53	-37.67	88.2	38.41	34.8	12.5	35.18	100	261	P	H	
		5922.6	41.47	-26.73	68.2	29.06	35.05	12.56	35.2	100	261	A	H	
	*	6025	96.13	-	-	83.36	35.35	12.64	35.22	100	261	P	H	
	*	6025	87.25	-	-	74.48	35.35	12.64	35.22	100	261	A	H	
													H	
														H
			5845.48	51.28	-36.92	88.2	39.15	34.8	12.51	35.18	264	49	P	V
			5917.48	41.78	-26.42	68.2	29.39	35.03	12.56	35.2	264	49	A	V
		*	6025	97.59	-	-	84.82	35.35	12.64	35.22	264	49	P	V
		*	6025	89.66	-	-	76.89	35.35	12.64	35.22	264	49	A	V
													V	
													V	
Remark	1. No other spurious found. 2. All results are PASS against Peak and Average limit line.													



Band 5 5925~6425MHz

WIFI 802.11ax HE80 Full (Harmonic @ 3m)

WIFI Ant. 3+4	Note	Frequency (MHz)	Level (dBμV/m)	Over Limit (dB)	Limit Line (dBμV/m)	Read Level (dBμV)	Antenna Factor (dB/m)	Path Loss (dB)	Preamp Factor (dB)	Ant Pos (cm)	Table Pos (deg)	Peak Avg. (P/A)	Pol. (H/V)
802.11ax HE160 Full CH 15 6025MHz		12050	43.86	-30.14	74	42.4	38.9	19.29	56.73	-	-	P	H
		18075	32.54	-41.46	74	50.15	37.54	4.74	59.89	-	-	P	H
													H
													H
		12050	44.36	-29.64	74	42.9	38.9	19.29	56.73	-	-	P	V
		18075	32.34	-41.66	74	49.95	37.54	4.74	59.89	-	-	P	V
													V
													V
802.11ax HE160 Full CH 47 6185MHz		12370	44.42	-29.58	74	42.56	39.14	19.58	56.86	-	-	P	H
		18555	33.21	-40.79	74	50.3	37.84	4.88	59.81	-	-	P	H
													H
													H
		12370	45.25	-28.75	74	43.39	39.14	19.58	56.86	-	-	P	V
		18555	32.51	-41.49	74	49.6	37.84	4.88	59.81	-	-	P	V
													V
													V
802.11ax HE160 Full CH 79 6345MHz		12690	45.86	-28.14	74	43.97	39.38	19.88	57.37	-	-	P	H
		19035	33.02	-40.98	74	50.09	37.82	5.01	59.9	-	-	P	H
													H
													H
		12690	45.7	-28.3	74	43.81	39.38	19.88	57.37	-	-	P	V
		19035	32.84	-41.16	74	49.91	37.82	5.01	59.9	-	-	P	V
													V
													V
Remark	<ol style="list-style-type: none"> No other spurious found. All results are PASS against Peak and Average limit line. The emission position marked as "-" means no suspected emission found with sufficient margin against limit line or noise floor only. 												



Band 6 - 6425~6525MHz

WIFI 802.11ax HE160 Full (Harmonic @ 3m)

WIFI Ant. 3+4	Note	Frequency (MHz)	Level (dBμV/m)	Over Limit (dB)	Limit Line (dBμV/m)	Read Level (dBμV)	Antenna Factor (dB/m)	Path Loss (dB)	Preamp Factor (dB)	Ant Pos (cm)	Table Pos (deg)	Peak Avg. (P/A)	Pol. (H/V)	
802.11ax HE160 Full CH 111 6505MHz		13010	45.26	-42.94	88.2	43.91	39.29	20.18	58.12	-	-	P	H	
		19515	32.89	-41.11	74	50.15	37.51	5.14	59.91	-	-	P	H	
													H	
													H	
			13010	45.24	-42.96	88.2	43.89	39.29	20.18	58.12	-	-	P	V
			19515	33.04	-40.96	74	50.3	37.51	5.14	59.91	-	-	P	V
													V	
													V	
Remark	<ol style="list-style-type: none"> No other spurious found. All results are PASS against Peak and Average limit line. The emission position marked as "-" means no suspected emission found with sufficient margin against limit line or noise floor only. 													



**Band 7 - 6525~6875MHz
WIFI 802.11ax HE160 Full (Harmonic @ 3m)**

WIFI Ant. 3+4	Note	Frequency (MHz)	Level (dBµV/m)	Over Limit (dB)	Limit Line (dBµV/m)	Read Level (dBµV)	Antenna Factor (dB/m)	Path Loss (dB)	Preamp Factor (dB)	Ant Pos (cm)	Table Pos (deg)	Peak Avg. (P/A)	Pol. (H/V)
802.11ax HE160 Full CH 143 6665MHz		13330	44.57	-29.43	74	42.87	39.37	20.54	58.21	-	-	P	H
		19995	32.69	-41.31	74	49.91	37.6	5.28	60.1	-	-	P	H
													H
													H
		13330	44.42	-29.58	74	42.72	39.37	20.54	58.21	-	-	P	V
		19995	32.61	-41.39	74	49.83	37.6	5.28	60.1	-	-	P	V
													V
802.11ax HE160 Full CH 175 6825MHz		13650	45.76	-42.44	88.2	44.21	38.9	20.89	58.24	-	-	P	H
		20475	33.14	-40.86	74	49.92	37.87	5.45	60.1	-	-	P	H
													H
													H
		13650	45.71	-42.49	88.2	44.16	38.9	20.89	58.24	-	-	P	V
		20475	34.11	-39.89	74	50.89	37.87	5.45	60.1	-	-	P	V
													V
Remark	1. No other spurious found. 2. All results are PASS against Peak and Average limit line. 3. The emission position marked as "-" means no suspected emission found with sufficient margin against limit line or noise floor only.												



Band 8 - 6875~7125MHz

WIFI 802.11ax HE20 Full (Band Edge @ 3m)

WIFI Ant. 3+4	Note	Frequency (MHz)	Level (dBμV/m)	Over Limit (dB)	Limit Line (dBμV/m)	Read Level (dBμV)	Antenna Factor (dB/m)	Path Loss (dB)	Preamp Factor (dB)	Ant Pos (cm)	Table Pos (deg)	Peak Avg. (P/A)	Pol. (H/V)
802.11ax HE20 Full CH 233 7115MHz	*	7115	86.97	-	-	72.6	36.07	13.74	35.44	100	200	P	H
	*	7115	77.32	-	-	62.95	36.07	13.74	35.44	100	200	A	H
		7125.02	73.87	-14.33	88.2	59.52	36.05	13.74	35.44	100	200	P	H
		7125.02	65.57	-2.63	68.2	51.22	36.05	13.74	35.44	100	200	A	H
													H
													H
	*	7115	89.44	-	-	75.07	36.07	13.74	35.44	100	300	P	V
	*	7115	79.89	-	-	65.52	36.07	13.74	35.44	100	300	A	V
		7125.02	73.35	-14.85	88.2	59	36.05	13.74	35.44	100	300	P	V
		7125.02	67.89	-0.31	68.2	53.54	36.05	13.74	35.44	100	300	A	V
												V	
												V	
Remark	1. No other spurious found. 2. All results are PASS against Peak and Average limit line.												



**Band 8 - 6875~7125MHz
WIFI 802.11ax HE40 Full (Band Edge @ 3m)**

WIFI Ant. 3+4	Note	Frequency (MHz)	Level (dBμV/m)	Over Limit (dB)	Limit Line (dBμV/m)	Read Level (dBμV)	Antenna Factor (dB/m)	Path Loss (dB)	Preamp Factor (dB)	Ant Pos (cm)	Table Pos (deg)	Peak Avg. (P/A)	Pol. (H/V)
802.11ax HE40 Full CH 227 7085MHz	*	7085	95.88	-	-	81.54	36.04	13.74	35.44	100	205	P	H
	*	7085	86.76	-	-	72.42	36.04	13.74	35.44	100	205	A	H
		7201.08	53.2	-35	88.2	38.72	36.2	13.73	35.45	100	205	P	H
		7219.44	42.99	-25.21	68.2	28.52	36.16	13.76	35.45	100	205	A	H
													H
													H
	*	7085	95.84	-	-	81.5	36.04	13.74	35.44	100	299	P	V
	*	7085	88.94	-	-	74.6	36.04	13.74	35.44	100	299	A	V
		7203.24	52.75	-35.45	88.2	38.28	36.19	13.73	35.45	100	299	P	V
		7216.56	43.02	-25.18	68.2	28.55	36.17	13.75	35.45	100	299	A	V
												V	
												V	
Remark	1. No other spurious found. 2. All results are PASS against Peak and Average limit line.												



**Band 8 - 6875~7125MHz
WIFI 802.11ax HE80 Full (Band Edge @ 3m)**

WIFI Ant. 3+4	Note	Frequency (MHz)	Level (dBμV/m)	Over Limit (dB)	Limit Line (dBμV/m)	Read Level (dBμV)	Antenna Factor (dB/m)	Path Loss (dB)	Preamp Factor (dB)	Ant Pos (cm)	Table Pos (deg)	Peak Avg. (P/A)	Pol. (H/V)
802.11ax HE80 Full CH 215 7025MHz	*	7025	94.58	-	-	80.31	35.95	13.75	35.43	101	198	P	H
	*	7025	86.65	-	-	72.38	35.95	13.75	35.43	101	198	A	H
		7137.8	51.21	-36.99	88.2	36.89	36.02	13.74	35.44	101	198	P	H
		7142.28	42.48	-25.72	68.2	28.16	36.02	13.74	35.44	101	198	A	H
													H
													H
	*	7025	95.49	-	-	81.22	35.95	13.75	35.43	100	297	P	V
	*	7025	89.35	-	-	75.08	35.95	13.75	35.43	100	297	A	V
		7130.92	52.11	-36.09	88.2	37.77	36.04	13.74	35.44	100	297	P	V
		7142.6	42.54	-25.66	68.2	28.23	36.01	13.74	35.44	100	297	A	V
												V	
												V	
Remark	1. No other spurious found. 2. All results are PASS against Peak and Average limit line.												



**Band 8 - 6875~7125MHz
WIFI 802.11ax HE160 Full (Band Edge @ 3m)**

WIFI Ant. 3+4	Note	Frequency (MHz)	Level (dBμV/m)	Over Limit (dB)	Limit Line (dBμV/m)	Read Level (dBμV)	Antenna Factor (dB/m)	Path Loss (dB)	Preamp Factor (dB)	Ant Pos (cm)	Table Pos (deg)	Peak Avg. (P/A)	Pol. (H/V)	
802.11ax HE160 Full CH 207 6985MHz	*	6985	95.4	-	-	81.13	35.97	13.73	35.43	100	203	P	H	
	*	6985	86.7	-	-	72.43	35.97	13.73	35.43	100	203	A	H	
		7158.76	52.8	-35.4	88.2	38.48	36.04	13.73	35.45	100	203	P	H	
		7218.28	43.01	-25.19	68.2	28.54	36.16	13.76	35.45	100	203	A	H	
													H	
														H
	*	6985	97.19	-	-	82.92	35.97	13.73	35.43	100	298	P	V	
	*	6985	88.95	-	-	74.68	35.97	13.73	35.43	100	298	A	V	
		7133.48	53.36	-34.84	88.2	39.03	36.03	13.74	35.44	100	298	P	V	
		7133.48	43.45	-24.75	68.2	29.12	36.03	13.74	35.44	100	298	A	V	
													V	
													V	
Remark	1. No other spurious found. 2. All results are PASS against Peak and Average limit line.													



**Band 8 - 6875~7125MHz
WIFI 802.11ax HE160 Full (Harmonic @ 3m)**

WIFI Ant. 3+4	Note	Frequency (MHz)	Level (dBμV/m)	Over Limit (dB)	Limit Line (dBμV/m)	Read Level (dBμV)	Antenna Factor (dB/m)	Path Loss (dB)	Preamp Factor (dB)	Ant Pos (cm)	Table Pos (deg)	Peak Avg. (P/A)	Pol. (H/V)	
802.11ax HE160 Full CH 207 6985MHz		13650	44.26	-43.94	88.2	42.71	38.9	20.89	58.24	-	-	P	H	
		20475	32.47	-41.53	74	49.25	37.87	5.45	60.1	-	-	P	H	
													H	
													H	
			13650	44.21	-43.99	88.2	42.66	38.9	20.89	58.24	-	-	P	V
			20475	33.1	-40.9	74	49.88	37.87	5.45	60.1	-	-	P	V
														V
Remark	1. No other spurious found. 2. All results are PASS against Peak and Average limit line. 3. The emission position marked as "-" means no suspected emission found with sufficient margin against limit line or noise floor only.													



Emission below 1GHz

WIFI 802.11ax HE20 Full (LF @ 3m)

WIFI	Note	Frequency	Level	Over	Limit	Read	Antenna	Path	Preamp	Ant	Table	Peak	Pol.
Ant.				Limit	Line	Level	Factor	Loss	Factor	Pos	Pos	Avg.	
3+4		(MHz)	(dBμV/m)	(dB)	(dBμV/m)	(dBμV)	(dB/m)	(dB)	(dB)	(cm)	(deg)	(P/A)	(H/V)
802.11ax HE20 Full LF		57.27	27.04	-12.96	40	43.61	12.09	1.35	30.01	-	-	P	H
		90.48	34	-9.5	43.5	47.7	14.69	1.6	29.99	-	-	P	H
		162.57	30.65	-12.85	43.5	42.16	16.34	2.13	29.98	-	-	P	H
		791.4	29.82	-16.18	46	27.26	27.8	4.37	29.61	-	-	P	H
		866.3	31.26	-14.74	46	26.89	28.88	4.63	29.14	-	-	P	H
		946.8	33.15	-12.85	46	26.97	30.04	4.86	28.72	-	-	P	H
		30.54	32.1	-7.9	40	37.04	24.17	0.92	30.03	-	-	P	V
		57.54	33	-7	40	49.64	12.01	1.36	30.01	-	-	P	V
		86.7	32.2	-7.8	40	46.38	14.23	1.59	30	-	-	P	V
		762.7	30.25	-15.75	46	27.89	27.73	4.29	29.66	-	-	P	V
		863.5	31.8	-14.2	46	27.44	28.9	4.62	29.16	-	-	P	V
		950.3	33.82	-12.18	46	27.33	30.33	4.87	28.71	-	-	P	V
Remark	<ol style="list-style-type: none"> No other spurious found. All results are PASS against limit line. The emission position marked as "-" means no suspected emission found with sufficient margin against limit line or noise floor only. 												



Note symbol

*	Fundamental Frequency which can be ignored. However, the level of any unwanted emissions shall not exceed the level of the fundamental frequency.
!	Test result is over limit line.
P/A	Peak or Average
H/V	Horizontal or Vertical



A calculation example for radiated spurious emission is shown as below:

WIFI	Note	Frequency	Level	Over	Limit	Read	Antenna	Path	Preamp	Ant	Table	Peak	Pol.
Ant.				Limit	Line	Level	Factor	Loss	Factor	Pos	Pos	Avg.	
3+4		(MHz)	(dBμV/m)	(dB)	(dBμV/m)	(dBμV)	(dB/m)	(dB)	(dB)	(cm)	(deg)	(P/A)	(H/V)
802.11b		2390	55.45	-18.55	74	54.51	32.22	4.58	35.86	103	308	P	H
CH 01													
2412MHz		2390	43.54	-10.46	54	42.6	32.22	4.58	35.86	103	308	A	H

1. Path Loss(dB) = Cable loss(dB) + Filter loss(dB) + Attenuator loss(dB)
2. Level(dBμV/m) = Antenna Factor(dB/m) + Path Loss(dB) + Read Level(dBμV) - Preamp Factor(dB)
3. Over Limit(dB) = Level(dBμV/m) – Limit Line(dBμV/m)

For Peak Limit @ 2390MHz:

1. Level(dBμV/m)
= Antenna Factor(dB/m) + Path Loss(dB) + Read Level(dBμV) - Preamp Factor(dB)
= 32.22(dB/m) + 4.58(dB) + 54.51(dBμV) – 35.86 (dB)
= 55.45 (dBμV/m)
2. Over Limit(dB)
= Level(dBμV/m) – Limit Line(dBμV/m)
= 55.45(dBμV/m) – 74(dBμV/m)
= -18.55(dB)

For Average Limit @ 2390MHz:

1. Level(dBμV/m)
= Antenna Factor(dB/m) + Path Loss(dB) + Read Level(dBμV) - Preamp Factor(dB)
= 32.22(dB/m) + 4.58(dB) + 42.6(dBμV) – 35.86 (dB)
= 43.54 (dBμV/m)
2. Over Limit(dB) = Level(dBμV/m) – Limit Line(dBμV/m)
= 43.54(dBμV/m) – 54(dBμV/m)
= -10.46(dB)

Both peak and average measured complies with the limit line, so test result is "PASS".



Appendix D. Radiated Spurious Emission Plots

Test Engineer :	Jesse Wang, Stan Hsieh and Ken Wu	Temperature :	23.1~25.3°C
		Relative Humidity :	53.6~59.1%

Note symbol

-L	Low channel location
-R	High channel location



Band 5 - 5925~6425MHz
WIFI 802.11ax HE20 Full (Band Edge @ 3m)

WIFI	Band 5 5925~6425MHz Band Edge @ 3m	
ANT	802.11ax HE20 Full CH01 5955MHz	
3+4	Horizontal	Fundamental
Peak	<p>Site : 03CH07-HY Condition : PEAK_BE[UNII]_E 3m HC_ANT_00066584 HORIZONTAL : RBW:1000.000kHz VBW:3000.000kHz SWT:Auto</p>	<p>Site : 03CH07-HY Condition : PEAK[UNII]_E 3m HC_ANT_00066584 HORIZONTAL : RBW:1000.000kHz VBW:3000.000kHz SWT:Auto</p>
Avg.	<p>Site : 03CH07-HY Condition : AVG_BE[UNII]_E 3m HF_ANT_00066584 HORIZONTAL : RBW:1000.000kHz VBW:0.010kHz SWT:Auto</p>	Left blank

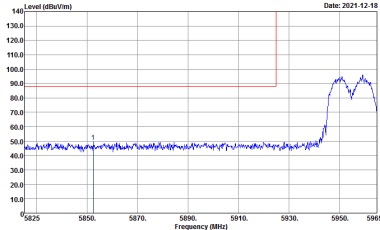
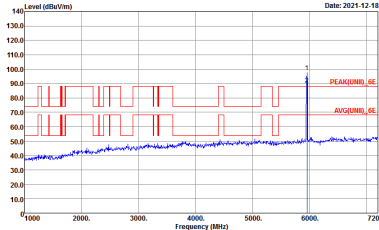
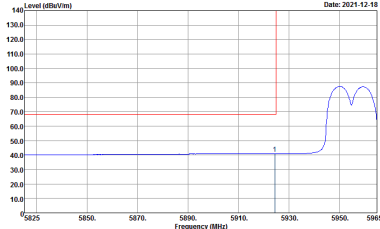

WIFI	Band 5 5925~6425MHz Band Edge @ 3m	
ANT	802.11ax HE20 Full CH01 5955MHz	
3+4	Vertical	Fundamental
Peak	 <p>Site : 03CH07-HY Condition : :PEAK_BE[UNII]_EE 3m HF_ANT_00066584 VERTICAL : RBW:1000.000kHz VBW:3000.000kHz SWT:Auto</p>	 <p>Site : 03CH07-HY Condition : :PEAK[UNII]_EE 3m HF_ANT_00066584 VERTICAL : RBW:1000.000kHz VBW:3000.000kHz SWT:Auto</p>
Avg.	 <p>Site : 03CH07-HY Condition : :AVG_BE[UNII]_EE 3m HF_ANT_00066584 VERTICAL : RBW:1000.000kHz VBW:0.0100kHz SWT:Auto</p>	Left blank

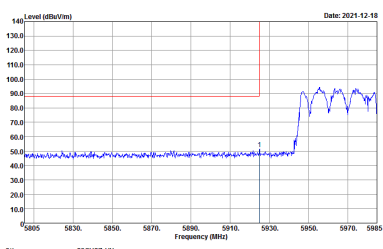
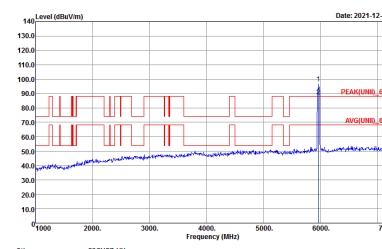
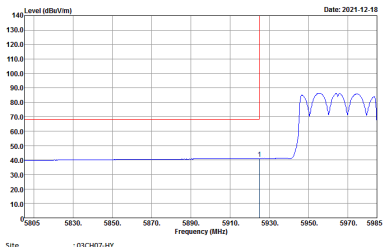

Band 5 5925~6425MHz
WIFI 802.11ax HE40 Full (Band Edge @ 3m)

WIFI	Band 5 5925~6425MHz Band Edge @ 3m	
ANT	802.11ax HE40 Full CH03 5965MHz	
3+4	Horizontal	Fundamental
Peak	 <p>Site : 03CH07-HY Condition : PEAK_BE(UNIT)_EE 3m HF_ANT_00066584 HORIZONTAL : RBW:1000.000kHz VBW:3000.000kHz SWTA:Auto</p>	 <p>Site : 03CH07-HY Condition : PEAK(UNIT)_EE 3m HF_ANT_00066584 HORIZONTAL : RBW:1000.000kHz VBW:3000.000kHz SWTA:Auto</p>
Avg.	 <p>Site : 03CH07-HY Condition : AVG_BE(UNIT)_EE 3m HF_ANT_00066584 HORIZONTAL : RBW:1000.000kHz VBW:0.010kHz SWTA:Auto</p>	Left blank

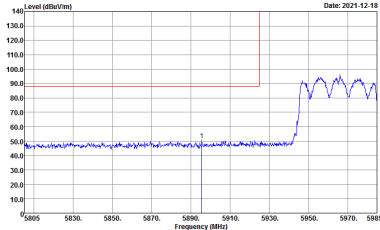
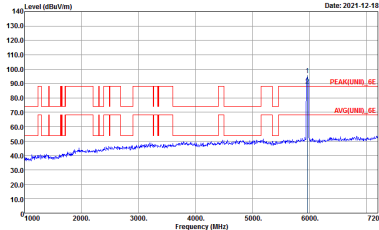
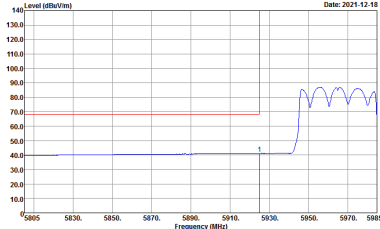

WIFI	Band 5 5925~6425MHz Band Edge @ 3m	
ANT	802.11ax HE40 Full CH03 5965MHz	
3+4	Vertical	Fundamental
Peak	 <p>Site : 03CH07-HY Condition : :PEAK_BE[UNII]_EE 3m HF_ANT_00066584 VERTICAL : RBW:1000.000kHz VBW:3000.000kHz SWT:Auto</p>	 <p>Site : 03CH07-HY Condition : :PEAK[UNII]_EE 3m HF_ANT_00066584 VERTICAL : RBW:1000.000kHz VBW:3000.000kHz SWT:Auto</p>
Avg.	 <p>Site : 03CH07-HY Condition : :AVG_BE[UNII]_EE 3m HF_ANT_00066584 VERTICAL : RBW:1000.000kHz VBW:0.0100kHz SWT:Auto</p>	Left blank



Band 5 5925~6425MHz
WIFI 802.11ax HE80 Full (Band Edge @ 3m)

WIFI	Band 5 5925~6425MHz Band Edge @ 3m	
ANT	802.11ax HE80 Full CH07 5985MHz	
3+4	Horizontal	Fundamental
Peak	<p>Site : 03CH07-HY Condition : PEAK_BE(UNIT)_EE 3m HF_ANT_00066584 HORIZONTAL : RBW:1000.000kHz VBW:3000.000kHz SWTA:Auto</p>	<p>Site : 03CH07-HY Condition : PEAK(UNIT)_EE 3m HF_ANT_00066584 HORIZONTAL : RBW:1000.000kHz VBW:3000.000kHz SWTA:Auto</p>
Avg.	<p>Site : 03CH07-HY Condition : AVG_BE(UNIT)_EE 3m HF_ANT_00066584 HORIZONTAL : RBW:1000.000kHz VBW:0.010kHz SWTA:Auto</p>	Left blank

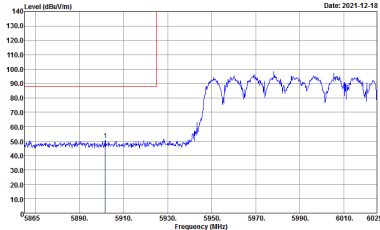
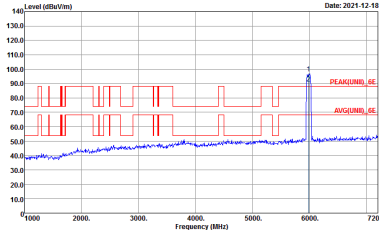
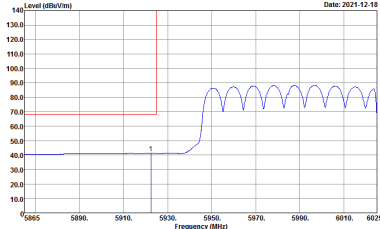

WIFI	Band 5 5925~6425MHz Band Edge @ 3m	
ANT	802.11ax HE80 Full CH07 5985MHz	
3+4	Vertical	Fundamental
Peak	 <p>Level (dBuV/m) vs Frequency (MHz) plot showing a peak at approximately 5985 MHz. The y-axis ranges from 10.0 to 140.0 dBuV/m, and the x-axis ranges from 5885 to 6025 MHz. A red line indicates the peak level at approximately 135 dBuV/m.</p> <p>Site : 03CH07-HY Condition : PEAK_BE[UNII]_EE 3m HF_ANT_00066584 VERTICAL : RBW:1000.000kHz VBW:3000.000kHz SWT:Auto</p>	 <p>Level (dBuV/m) vs Frequency (MHz) plot showing a peak at approximately 6000 MHz. The y-axis ranges from 10.0 to 140.0 dBuV/m, and the x-axis ranges from 1000 to 7200 MHz. A red line indicates the peak level at approximately 100 dBuV/m.</p> <p>Site : 03CH07-HY Condition : PEAK[UNII]_EE 3m HF_ANT_00066584 VERTICAL : RBW:1000.000kHz VBW:3000.000kHz SWT:Auto</p>
Avg.	 <p>Level (dBuV/m) vs Frequency (MHz) plot showing an average level at approximately 5985 MHz. The y-axis ranges from 10.0 to 140.0 dBuV/m, and the x-axis ranges from 5885 to 6025 MHz. A red line indicates the average level at approximately 80 dBuV/m.</p> <p>Site : 03CH07-HY Condition : AVG_BE[UNII]_EE 3m HF_ANT_00066584 VERTICAL : RBW:1000.000kHz VBW:0.0100kHz SWT:Auto</p>	Left blank



Band 5 5925~6425MHz
WIFI 802.11ax HE160 Full (Band Edge @ 3m)

WIFI	Band 5 5925~6425MHz Band Edge @ 3m	
ANT	802.11ax HE160 Full CH15 6025MHz	
3+4	Horizontal	Fundamental
Peak	<p>Site : 03CH07-HY Condition : PEAK_BE(UNIT)_EE 3m HF_ANT_00066584 HORIZONTAL : RBW:1000.000kHz VBW:3000.000kHz SWTA:Auto</p>	<p>Site : 03CH07-HY Condition : PEAK(UNIT)_EE 3m HF_ANT_00066584 HORIZONTAL : RBW:1000.000kHz VBW:3000.000kHz SWTA:Auto</p>
Avg.	<p>Site : 03CH07-HY Condition : AVG_BE(UNIT)_EE 3m HF_ANT_00066584 HORIZONTAL : RBW:1000.000kHz VBW:0.010kHz SWTA:Auto</p>	Left blank



WIFI	Band 5 5925~6425MHz Band Edge @ 3m	
ANT	802.11ax HE160 Full CH15 6025MHz	
3+4	Vertical	Fundamental
Peak	<p>Site : 03CH07-HY Condition : PEAK_BE(LIN1) _EE 3m HF_ANT_00066584 VERTICAL : RBW:1000.000kHz VBW:3000.000kHz SWT:Auto</p>	<p>Site : 03CH07-HY Condition : PEAK(LIN1) _EE 3m HF_ANT_00066584 VERTICAL : RBW:1000.000kHz VBW:3000.000kHz SWT:Auto</p>
Avg.	<p>Site : 03CH07-HY Condition : AVG_BE(LIN1) _EE 3m HF_ANT_00066584 VERTICAL : RBW:1000.000kHz VBW:0.0100kHz SWT:Auto</p>	Left blank



Band 5 5925~6425MHz
WIFI 802.11ax HE160 Full (Harmonic @ 3m)

WIFI	Band 5 5925~6425MHz Harmonic @ 3m	
ANT	802.11ax HE160 Full CH15 6025MHz	
3+4	Horizontal	Vertical
Peak Avg.	<p>Site : 03CH07-HY Condition : PEAK(UNII)_E 1m SHF-EHF_3170251 HORIZONTAL Detector : Peak</p>	<p>Site : 03CH07-HY Condition : PEAK(UNII)_E 1m SHF-EHF_3170251 VERTICAL Detector : Peak</p>



WIFI	Band 5 5925~6425MHz Harmonic @ 3m	
ANT	802.11ax HE160 Full CH47 6185MHz	
3+4	Horizontal	Vertical
Peak Avg.	<p>Site : 03CH07-HY Condition : PEARU(NII)_GE 1m SHF-EHF_9170251 HORIZONTAL Detector : Peak</p>	<p>Site : 03CH07-HY Condition : PEARU(NII)_GE 1m SHF-EHF_9170251 VERTICAL Detector : Peak</p>