

FCC Test Report (Co-Located)

Report No.: RFBBQZ-WTW-P22060184-4

FCC ID: PY322300569

Test Model: WAX214v2

Received Date: 2022/6/8

Test Date: 2022/9/21

Issued Date: 2022/10/3

Applicant and Manufacturer: NETGEAR, INC.

Address: 350 East Plumeria Drive San Jose, CA 95134

Issued By: Bureau Veritas Consumer Products Services (H.K.) Ltd., Taoyuan Branch
Lin Kou Laboratories

Lab Address: No. 47-2, 14th Ling, Chia Pau Vil., Lin Kou Dist., New Taipei City, Taiwan

Test Location: No. 19, Hwa Ya 2nd Rd., Wen Hwa Vil., Kwei Shan Dist., Taoyuan City
33383, TAIWAN

**FCC Registration /
Designation Number:** 788550 / TW0003



This report is governed by, and incorporates by reference, the Conditions of Testing as posted at the date of issuance of this report at <http://www.bureauveritas.com/home/about-us/our-business/cps/about-us/terms-conditions/> and is intended for your exclusive use. Any copying or replication of this report to or for any other person or entity, or use of our name or trademark, is permitted only with our prior written permission. This report sets forth our findings solely with respect to the test samples identified herein. The results set forth in this report are not indicative or representative of the quality or characteristics of the lot from which a test sample was taken or any similar or identical product unless specifically and expressly noted. Our report includes all of the tests requested by you and the results thereof based upon the information that you provided to us. Measurement uncertainty is only provided upon request for accredited tests. Statements of conformity are based on simple acceptance criteria without taking measurement uncertainty into account, unless otherwise requested in writing. You have 60 days from date of issuance of this report to notify us of any material error or omission caused by our negligence or if you require measurement uncertainty; provided, however, that such notice shall be in writing and shall specifically address the issue you wish to raise. A failure to raise such issue within the prescribed time shall constitute your unqualified acceptance of the completeness of this report, the tests conducted and the correctness of the report contents.

Table of Contents

Release Control Record	3
1 Certificate of Conformity	4
2 Summary of Test Results	5
2.1 Measurement Uncertainty.....	5
2.2 Modification Record.....	5
3 General Information	6
3.1 General Description of EUT.....	6
3.2 Description of Test Modes.....	11
3.2.1 Test Mode Applicability and Tested Channel Detail.....	14
3.3 Description of Support Units.....	15
3.3.1 Configuration of System under Test.....	15
3.4 General Description of Applied Standards.....	16
4 Test Types and Results	17
4.1 Radiated Emission and Bandedge Measurement.....	17
4.1.1 Limits of Radiated Emission and Bandedge Measurement.....	17
4.1.2 Test Instruments.....	18
4.1.3 Test Procedures.....	20
4.1.4 Deviation from Test Standard.....	20
4.1.5 Test Setup.....	21
4.1.6 EUT Operating Conditions.....	22
4.1.7 Test Results.....	23
4.2 Conducted Out of Band Emission Measurement.....	41
4.2.1 Limits of Conducted Out of Band Emission Measurement.....	41
4.2.2 Test Setup.....	41
4.2.3 Test Instruments.....	41
4.2.4 Test Procedure.....	41
4.2.5 Deviation from Test Standard.....	41
4.2.6 EUT Operating Condition.....	41
4.2.7 Test Results.....	42
5 Pictures of Test Arrangements	43
Annex A – Band Edge Measurement	44
Appendix – Information of the Testing Laboratories	45

Release Control Record

Issue No.	Description	Date Issued
RFBBQZ-WTW-P22060184-4	Original release.	2022/10/3

1 Certificate of Conformity

Product: WiFi 6 AX1800 Dual Band Access Point

Brand: NETGEAR

Test Model: WAX214v2

Sample Status: Engineering sample

**Applicant and
Manufacturer:** NETGEAR, INC.

Test Date: 2022/9/21

Standards: 47 CFR FCC Part 15, Subpart C (Section 15.247)
47 CFR FCC Part 15, Subpart E (Section 15.407)
ANSI C63.10:2013

The above equipment has been tested by **Bureau Veritas Consumer Products Services (H.K.) Ltd., Taoyuan Branch**, and found compliance with the requirement of the above standards. The test record, data evaluation & Equipment Under Test (EUT) configurations represented herein are true and accurate accounts of the measurements of the sample's RF characteristics under the conditions specified in this report.

Prepared by : Celine Chou , **Date:** 2022/10/3
Celine Chou / Senior Specialist

Approved by : Jeremy Lin , **Date:** 2022/10/3
Jeremy Lin / Project Engineer

2 Summary of Test Results

Applied Standard:	47 CFR FCC Part 15, Subpart C (Section 15.247) 47 CFR FCC Part 15, Subpart E (Section 15.407)		
FCC Clause	Test Item	Result	Remarks
15.205 / 15.209 / 15.247(d) 15.407(b) (1/2/3/4(i)/5/9/10)	Radiated Emissions	Pass	Meet the requirement of limit. Minimum passing margin is -2.9dB at 11570.00MHz.

Note: Determining compliance based on the results of the compliance measurement, not taking into account measurement instrumentation uncertainty.

2.1 Measurement Uncertainty

Where relevant, the following measurement uncertainty levels have been estimated for tests performed on the EUT as specified in CISPR 16-4-2:

Measurement	Frequency	Expanded Uncertainty (k=2) (\pm)
Radiated Emissions up to 1 GHz	9 kHz ~ 30 MHz	3.59 dB
	30 MHz ~ 1 GHz	3.60 dB
Radiated Emissions above 1 GHz	1 GHz ~ 18 GHz	2.29 dB
	18 GHz ~ 40 GHz	2.29 dB

2.2 Modification Record

There were no modifications required for compliance.

3 General Information

3.1 General Description of EUT

Product	WiFi 6 AX1800 Dual Band Access Point
Brand	NETGEAR
Test Model	WAX214v2
Sample Status	Engineering sample
Power Supply Rating	12 Vdc (adapter) 55.5 Vdc (POE)
Modulation Type	CCK, DQPSK, DBPSK for DSSS 256QAM, 64QAM, 16QAM, QPSK, BPSK for OFDM 1024QAM, 256QAM, 64QAM, 16QAM, QPSK, BPSK for OFDMA
Transfer Rate	802.11a: 54/48/36/24/18/12/9/6Mbps 802.11b: 11/5.5/2/1Mbps 802.11g: 54/48/36/24/18/12/9/6Mbps 802.11n: up to 300Mbps VHT: up to 400 Mbps (2.4GHz Band) 802.11ac: up to 866.7Mbps (5GHz Band) 802.11ax: up to 574Mbps (2.4GHz Band) 802.11ax: up to 1200Mbps (5GHz Band)
Operating Frequency	2.4GHz: 2412 ~ 2462MHz 5.0GHz: 5180 ~ 5240MHz, 5250 ~ 5320MHz, 5500 ~ 5720MHz, 5745 ~ 5825MHz, 5845 ~ 5885MHz

Number of Channel	<p>2412 ~ 2462 MHz: 802.11b, 802.11g, 802.11n (HT20), VHT20, 802.11ax (HE20): 11 802.11n (HT40), VHT40, 802.11ax (HE40): 7</p> <p>5180 ~ 5240 MHz: 802.11a, 802.11n (HT20), 802.11ac (VHT20), 802.11ax (HE20): 4 802.11n (HT40), 802.11ac (VHT40), 802.11ax (HE40): 2 802.11ac (VHT80), 802.11ax (HE80): 1</p> <p>5260 ~ 5320 MHz: 802.11a, 802.11n (HT20), 802.11ac (VHT20), 802.11ax (HE20): 4 802.11n (HT40), 802.11ac (VHT40), 802.11ax (HE40): 2 802.11ac (VHT80), 802.11ax (HE80): 1</p> <p>5500 ~ 5720 MHz: 802.11a, 802.11n (HT20), 802.11ac (VHT20), 802.11ax (HE20): 12 802.11n (HT40), 802.11ac (VHT40), 802.11ax (HE40): 6 802.11ac (VHT80), 802.11ax (HE80): 3</p> <p>5745 ~ 5825 MHz: 802.11a, 802.11n (HT20), 802.11ac (VHT20), 802.11ax (HE20): 5 802.11n (HT40), 802.11ac (VHT40), 802.11ax (HE40): 2 802.11ac (VHT80), 802.11ax (HE80): 1</p> <p>5845 ~ 5885 MHz: 802.11a, 802.11n (HT20), 802.11ac (VHT20), 802.11ax (HE20): 3 802.11n (HT40), 802.11ac (VHT40), 802.11ax (HE40): 2 802.11ac (VHT80), 802.11ax (HE80): 1</p>
Output Power	<p>CDD Mode: 2412 ~ 2462 MHz: 422.810 mW (26.26 dBm) (Conducted Power) 5180 ~ 5240 MHz: 809.205 mW (29.08 dBm) (Conducted Power) 5260 ~ 5320 MHz: 209.104 mW (23.20 dBm) (Conducted Power) 5500 ~ 5720 MHz: 211.369 mW (23.25 dBm) (Conducted Power) 5745 ~ 5825 MHz: 833.88 mW (29.21 dBm) (Conducted Power) 5845 ~ 5885 MHz: 30.88dBm (1224.616mW) (EIRP)</p> <p>Beamforming Mode: 2412 ~ 2462MHz: 391.325 mW (25.93 dBm) (Conducted Power) 5180 ~ 5240 MHz: 809.205 mW (29.08 dBm) (Conducted Power) 5260 ~ 5320 MHz: 209.104 mW (23.20 dBm) (Conducted Power) 5500 ~ 5720 MHz: 211.369 mW (23.25 dBm) (Conducted Power) 5745 ~ 5825 MHz: 833.88 mW (29.21 dBm) (Conducted Power) 5845 ~ 5885MHz: 33.53dBm (2254.239mW) (EIRP)</p>
Antenna Type	Refer to Note
Antenna Connector	Refer to Note
Accessory Device	Refer to Note
Cable Supplied	NA

Note:

1. The EUT incorporates a MIMO function. Physically, the EUT provides 2 completed transmitters and 2 receivers.

2.4 GHz Band		
Modulation Mode	Tx & Rx Configuration	
802.11b	2TX	2RX
802.11g	2TX	2RX
802.11n (HT20)	2TX	2RX
802.11n (HT40)	2TX	2RX
VHT20	2TX	2RX
VHT40	2TX	2RX
802.11ax (HE20)	2TX	2RX
802.11ax (HE40)	2TX	2RX

Note:

1. All of modulation mode support beamforming function except 802.11b/g modulation mode.
2. The EUT support Beamforming and CDD mode, therefore both mode were investigated and the worst case scenario was identified. The worst case data were presented in test report.
3. The modulation and bandwidth are similar for 802.11n mode for 20 MHz / 40 MHz and VHT mode for 20 MHz / 40 MHz, therefore the manufacturer will control the power for 802.11n/VHT mode is the same as the 802.11ax or more lower than it and investigated worst case to representative mode in test report.

5 GHz Band		
Modulation Mode	Tx & Rx Configuration	
802.11a	2TX	3RX
802.11n (HT20)	2TX	3RX
802.11n (HT40)	2TX	3RX
802.11ac (VHT20)	2TX	3RX
802.11ac (VHT40)	2TX	3RX
802.11ac (VHT80)	2TX	3RX
802.11ax (HE20)	2TX	3RX
802.11ax (HE40)	2TX	3RX
802.11ax (HE80)	2TX	3RX

Note:

1. All of modulation mode support beamforming function except 802.11a modulation mode.
2. The EUT support Beamforming and CDD mode, therefore both mode were investigated and the worst case scenario was identified. The worst case data were presented in test report.
3. The modulation and bandwidth are similar for 802.11n mode for 20 MHz / 40 MHz, 802.11ac mode for 20 MHz / 40 MHz / 80 MHz and 802.11ax mode for 20 MHz / 40 MHz / 80 MHz, therefore the manufacturer will control the power for 802.11n/ac mode is the same as the 802.11ax or more lower than it and investigated worst case to representative mode in test report.

2. The EUT uses following accessories.

Adapter 1	
Brand	NETGEAR
Model	AD2076F10
Part Number	332-10993-02
Input Power	100-120 Vac, 50/60 Hz, 0.56 A
Output Power	12 Vdc, 1.5 A
DC cable	1.8m DC cable without core

Adapter 2	
Brand	NETGEAR
Model	ADS-18FQ-12 12018EPCU-L ADS-18FQ-12 12018EPC-L
Part Number	332-11523-02
Input Power	100-120 Vac, 60 Hz, Max. 0.7 A
Output Power	12 Vdc, 1.5 A
DC cable	1.8m DC cable without core

Adapter 3	
Brand	NETGEAR
Model	2AAJ018F 1
Part Number	332-11572-01
Input Power	100-120 Vac, 50/60 Hz, 0.6 A
Output Power	12.0 Vdc, 1.5 A
DC cable	1.83m DC cable without core

POE (for support unit only)	
Brand	BUFFALO
Model	BIJ-POE-1P2GH
Input Power	100-240 Vac, 1.1 A, 50/60 Hz
Output Power	55.5 Vdc, 0.54 A

3. The antenna information is listed as below.

Antenna Type	PIFA
Connector Type	IPEX
Antenna Gain	Directional Gain (dBi)
2400~2483.5MHz	6.29
5150~5250MHz	6.03
5250~5350MHz	6.07
5470~5725MHz	6.04
5725~5850MHz	6.27

Antenna Type	PIFA	
Connector Type	IPEX	
Antenna Gain(dBi)	Chain 0	Chain 1
5845 ~ 5885MHz	4.40	4.30

* The detailed antenna information, please refer to the Test report-Antenna Spec.pdf.

4. The above EUT information is declared by manufacturer and for more detailed features description, please refer to the manufacturer's specifications or user's manual.

3.2 Description of Test Modes

For WLAN 2.4G:

11 channels are provided for 802.11b, 802.11g, 802.11n (HT20), VHT20, 802.11ax (HE20):

Channel	Frequency	Channel	Frequency
1	2412MHz	7	2442MHz
2	2417MHz	8	2447MHz
3	2422MHz	9	2452MHz
4	2427MHz	10	2457MHz
5	2432MHz	11	2462MHz
6	2437MHz		

7 channels are provided for 802.11n (HT40), VHT40, 802.11ax (HE40):

Channel	Frequency	Channel	Frequency
3	2422MHz	7	2442MHz
4	2427MHz	8	2447MHz
5	2432MHz	9	2452MHz
6	2437MHz		

For 5180 ~ 5240 MHz:

4 channels are provided for 802.11a, 802.11n (HT20), 802.11ac (VHT20) and 802.11ax (HE20):

Channel	Frequency	Channel	Frequency
36	5180 MHz	44	5220 MHz
40	5200 MHz	48	5240 MHz

2 channels are provided for 802.11n (HT40), 802.11ac (VHT40) and 802.11ax (HE40):

Channel	Frequency	Channel	Frequency
38	5190 MHz	46	5230 MHz

1 channel is provided for 802.11ac (VHT80), 802.11ax (HE80):

Channel	Frequency
42	5210MHz

For 5260 ~ 5320MHz:

4 channels are provided for 802.11a, 802.11n (HT20), 802.11ac (VHT20) and 802.11ax (HE20):

Channel	Frequency	Channel	Frequency
52	5260 MHz	60	5300 MHz
56	5280 MHz	64	5320 MHz

2 channels are provided for 802.11n (HT40), 802.11ac (VHT40) and 802.11ax (HE40):

Channel	Frequency	Channel	Frequency
54	5270 MHz	62	5310 MHz

1 channels are provided for 802.11ac (VHT80) and 802.11ax (HE80):

Channel	Frequency
58	5290MHz

For 5500 ~ 5720MHz:

12 channels are provided for 802.11a, 802.11n (HT20), 802.11ac (VHT20), 802.11ax (HE20):

Channel	Frequency	Channel	Frequency
100	5500 MHz	124	5620 MHz
104	5520 MHz	128	5640 MHz
108	5540 MHz	132	5660 MHz
112	5560 MHz	136	5680 MHz
116	5580 MHz	140	5700 MHz
120	5600 MHz	144	5720 MHz

6 channels are provided for 802.11n (HT40), 802.11ac (VHT40), 802.11ax (HE40):

Channel	Frequency	Channel	Frequency
102	5510 MHz	126	5630 MHz
110	5550 MHz	134	5670 MHz
118	5590 MHz	142	5710 MHz

3 channels are provided for 802.11ac (VHT80), 802.11ax (HE80):

Channel	Frequency	Channel	Frequency
106	5530 MHz	138	5690 MHz
122	5610 MHz		

For 5745 ~ 5825MHz:

5 channels are provided for 802.11a, 802.11n (HT20), 802.11ac (VHT20), 802.11ax (HE20):

Channel	Frequency	Channel	Frequency
149	5745MHz	161	5805MHz
153	5765MHz	165	5825MHz
157	5785MHz		

2 channels are provided for 802.11n (HT40), 802.11ac (VHT40), 802.11ax (HE40):

Channel	Frequency	Channel	Frequency
151	5755MHz	159	5795MHz

1 channel is provided for 802.11ac (VHT80), 802.11ax (HE80):

Channel	Frequency
155	5775MHz

For 5845 ~ 5885MHz:

3 channels are provided for 802.11a, 802.11n (HT20), 802.11ac (VHT20), 802.11ax (HE20):

Channel	Frequency	Channel	Frequency	Channel	Frequency
*169	5845.5 MHz	173	5865 MHz	177	5885 MHz

2 channels are provided for 802.11n (HT40), 802.11ac (VHT40), 802.11ax (HE40):

Channel	Frequency	Channel	Frequency
*167	5835 MHz	175	5875 MHz

1 channel is provided for 802.11ac (VHT80), 802.11ax (HE80):

Channel	Frequency
*171	5855 MHz

Note: * Straddle channels.

3.2.1 Test Mode Applicability and Tested Channel Detail

EUT Configure Mode	Applicable to		Description
	RE \geq 1G	RE<1G	
A	√	√	Powered by adapter 1
B	-	√	Powered by adapter 2
C	-	√	Powered by adapter 3
D	-	√	Powered by POE

Where RE \geq 1G: Radiated Emission above 1GHz & Bandedge Measurement RE<1G: Radiated Emission below 1GHz

Note:

1. The EUT had been pre-tested on the positioned of each 3 axis. The worst case was found when positioned on **Y-plane**.
2. "-": Means no effect.

Radiated Emission Test (Above 1 GHz):

- Pre-Scan has been conducted to determine the worst-case mode from all possible combinations between available modulations, data rates and antenna ports (if EUT with antenna diversity architecture).
- Following channel(s) was (were) selected for the final test as listed below.

EUT Configure Mode	Mode	Freq. Range (MHz)	Available Channel	Tested Channel	Modulation Technology
A	802.11b + 802.11ax (HE20)	2412-2462	1 to 11	6 + 157	DSSS
		5745-5825	149 to 165		OFDMA
A	802.11b + 802.11ax (HE40)	2412-2462	1 to 11	6 + 167	DSSS
		5835-5875	167 to 175		OFDMA

Radiated Emission Test (Below 1GHz):

- Pre-Scan has been conducted to determine the worst-case mode from all possible combinations between available modulations, data rates and antenna ports (if EUT with antenna diversity architecture).
- Following channel(s) was (were) selected for the final test as listed below.

EUT Configure Mode	Mode	Freq. Range (MHz)	Available Channel	Tested Channel	Modulation Technology
A, B, C, D	802.11b + 802.11ax (HE20)	2412-2462	1 to 11	6 + 157	DSSS
		5745-5825	149 to 165		OFDMA
A, B, C, D	802.11b + 802.11ax (HE40)	2412-2462	1 to 11	6 + 167	DSSS
		5835-5875	167 to 175		OFDMA

Test Condition:

Applicable to	Environmental Conditions	Input Power	Tested by
RE \geq 1G	23 deg. C, 66% RH	120Vac, 60Hz	Titan Hsu
RE<1G	23 deg. C, 66% RH	120Vac, 60Hz 55.5Vdc	Titan Hsu

3.3 Description of Support Units

The EUT has been tested as an independent unit together with other necessary accessories or support units. The following support units or accessories were used to form a representative test configuration during the tests.

ID	Product	Brand	Model No.	Serial No.	FCC ID	Remarks
A	Notebook	DELL	E5430	2RL3YW1	N/A	Provided by Lab
B	POE	Buffalo	BIJ-POE-1P2GH	N/A	N/A	Supplied by applicant

ID	Cable Descriptions	Qty.	Length (m)	Shielding (Yes/No)	Cores (Qty.)	Remarks
1	RJ-45 Cable	1	10	N/A	N/A	N/A
2	RJ-45 Cable	1	1.5	N/A	N/A	N/A

3.3.1 Configuration of System under Test

Test Mode A, B, C

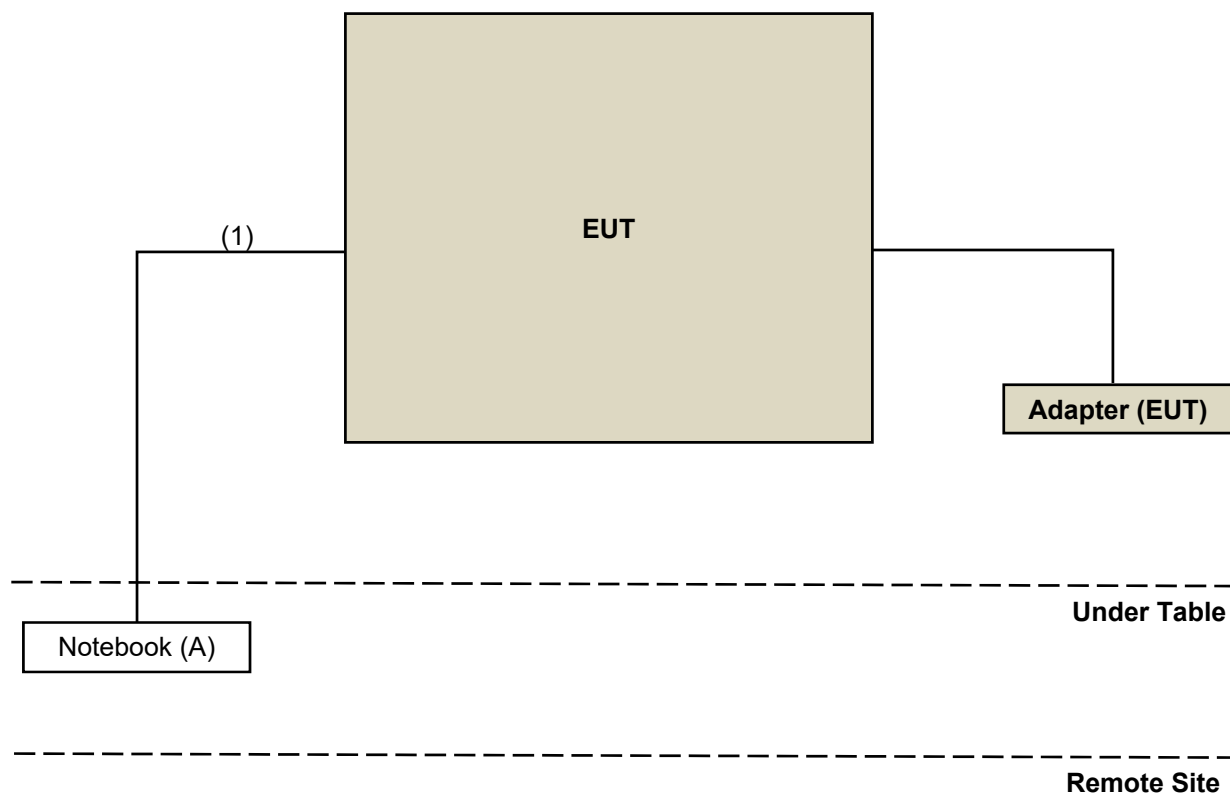

Test Mode D

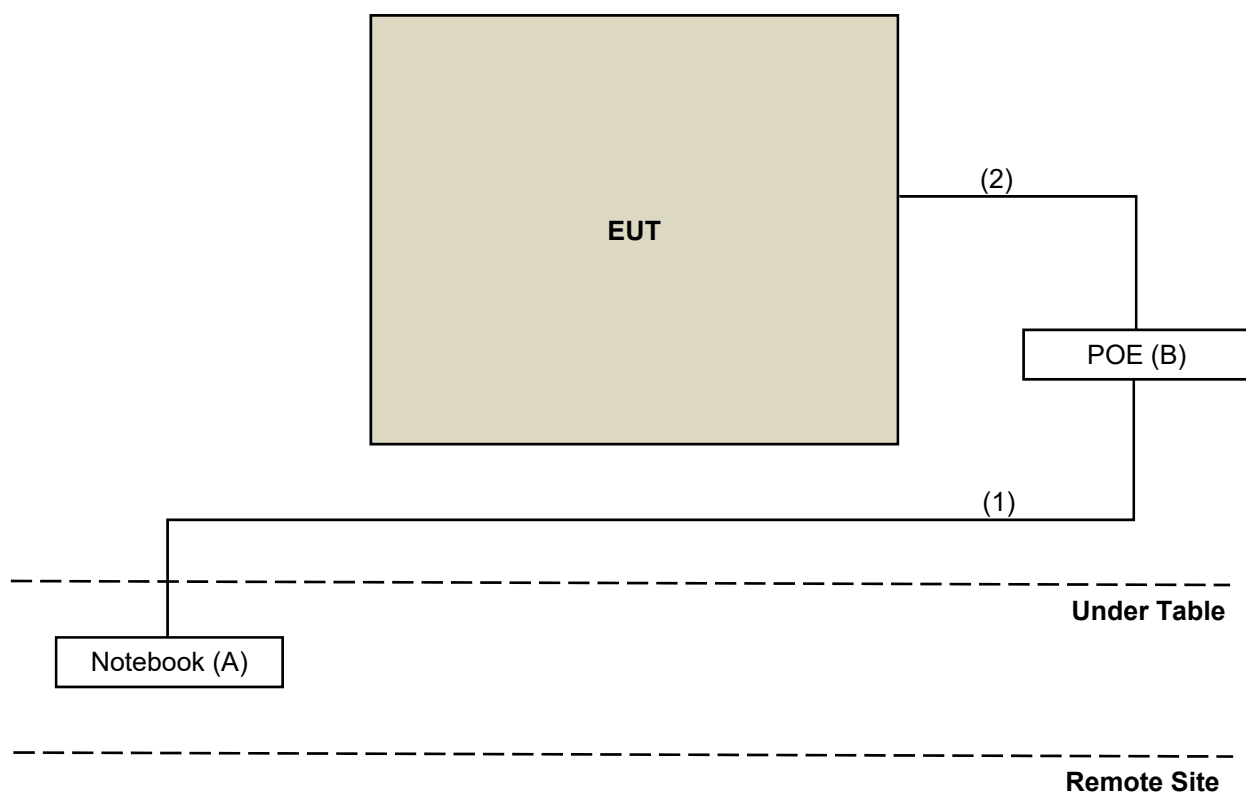

3.4 General Description of Applied Standards

The EUT is a RF Product. According to the specifications of the manufacturer, it must comply with the requirements of the following standards and references:

Test Standard:

FCC Part 15, Subpart C (15.247)

FCC Part 15, Subpart E (15.407)

ANSI C63.10-2013

All test items have been performed and recorded as per the above standards.

References Test Guidance:

KDB 558074 D01 15.247 Meas Guidance v05r02

KDB 789033 D02 General UNII Test Procedure New Rules v02r01

KDB 662911 D01 Multiple Transmitter Output v02r01

KDB 291074 D02 EMC Measurement v01

All test items have been performed as a reference to the above KDB test guidance.

4 Test Types and Results

4.1 Radiated Emission and Bandedge Measurement

4.1.1 Limits of Radiated Emission and Bandedge Measurement

Radiated emissions which fall in the restricted bands must comply with the radiated emission limits specified as below table.

Frequencies (MHz)	Field Strength (microvolts/meter)	Measurement Distance (meters)
0.009 ~ 0.490	2400/F(kHz)	300
0.490 ~ 1.705	24000/F(kHz)	30
1.705 ~ 30.0	30	30
30 ~ 88	100	3
88 ~ 216	150	3
216 ~ 960	200	3
Above 960	500	3

Note:

1. The lower limit shall apply at the transition frequencies.
2. Emission level (dBuV/m) = 20 log Emission level (uV/m).
3. For frequencies above 1000MHz, the field strength limits are based on average detector, however, the peak field strength of any emission shall not exceed the maximum permitted average limits, specified above by more than 20dB under any condition of modulation.

Limits of unwanted emission out of the restricted bands

Applicable To		Limit	
789033 D02 General UNII Test Procedure New Rules v02r01		Field Strength at 3m	
		PK: 74 (dBµV/m)	AV: 54 (dBµV/m)
Frequency Band	Applicable To	EIRP Limit	Equivalent Field Strength at 3m
5150~5250 MHz	15.407(b)(1)	PK: -27 (dBm/MHz)	PK: 68.2(dBµV/m)
5250~5350 MHz	15.407(b)(2)		
5470~5725 MHz	15.407(b)(3)		
5725~5850 MHz	<input checked="" type="checkbox"/> 15.407(b)(4)(i)	PK: -27 (dBm/MHz) ^{*1} PK: 10 (dBm/MHz) ^{*2} PK: 15.6 (dBm/MHz) ^{*3} PK: 27 (dBm/MHz) ^{*4}	PK: 68.2(dBµV/m) ^{*1} PK: 105.2 (dBµV/m) ^{*2} PK: 110.8(dBµV/m) ^{*3} PK: 122.2 (dBµV/m) ^{*4}
^{*1} beyond 75 MHz or more above of the band edge. ^{*3} below the band edge increasing linearly to a level of 15.6 dBm/MHz at 5 MHz above.		^{*2} below the band edge increasing linearly to 10 dBm/MHz at 25 MHz above. ^{*4} from 5 MHz above or below the band edge increasing linearly to a level of 27 dBm/MHz at the band edge.	

Note: The following formula is used to convert the equipment isotropic radiated power (eirp) to field strength:

$$E = \frac{1000000\sqrt{30P}}{3} \mu\text{V/m, where P is the eirp (Watts).}$$

4.1.2 Test Instruments

Unwanted Emissions below 1 GHz

Description Manufacturer	Model No.	Serial No.	Calibrated Date	Calibrated Until
Antenna Tower inn-co GmbH	MA 4000	010303	N/A	N/A
Bi_Log Antenna Schwarbeck	VULB9168	9168-155	11/1/2021	10/31/2022
Loop Antenna TESEQ	HLA 6121	45745	7/27/2022	7/26/2023
Pre_Amplifier Agilent	8447D	2944A10631	5/14/2022	5/13/2023
RF Coaxial Cable EMCI	5D-NM-BM	140903+140902	1/15/2022	1/14/2023
	EMC102-KM-KM-600	150928	7/9/2022	7/8/2023
	EMC102-KM-KM-3000	150929	7/9/2022	7/8/2023
Software BV ADT	ADT_Radiated_ V7.6.15.9.5	N/A	N/A	N/A
Spectrum Analyzer R&S	FSW43	101582	4/13/2022	4/12/2023
Test Receiver R&S	ESCI	100424	12/30/2021	12/29/2022
Turn Table BV ADT	TT100	TT93021705	N/A	N/A
Turn Table Controller BV ADT	SC100	SC93021705	N/A	N/A

- Note: 1. The calibration interval of the above test instruments is 12 months and the calibrations are traceable to NML/ROC and NIST/USA.
2. The test was performed in HY - 966 chamber 3.

Unwanted Emissions above 1 GHz

Description Manufacturer	Model No.	Serial No.	Calibrated Date	Calibrated Until
Antenna Tower inn-co GmbH	MA 4000	010303	N/A	N/A
Boresight antenna tower fixture BV	BAF-02	5	N/A	N/A
Horn Antenna Schwarzbeck	BBHA 9170	BBHA9170241	10/26/2021	10/25/2022
Pre-Amplifier EMCI	EMC 184045	980116	10/5/2021	10/4/2022
Pre_Amplifier KEYSIGHT	83017A	MY53270295	5/14/2022	5/13/2023
RF cable HUBER+SUHNER	Sucoflex 104	MY 13380+295012/04	5/14/2022	5/13/2023
RF Coaxial Cable HUBER+SUHNER	SUCOFLEX 104	Cable-CH4-03(250724)	5/14/2022	5/13/2023
		CABLE-CH9- (250795/4)	1/15/2022	1/14/2023
RF Coaxial Cable HUBER+SUHNER&EMCI	SUCOFLEX 104& EMC104-SM-SM8000	CABLE-CH9-02 (248780+171006)	1/15/2022	1/14/2023
Software BV ADT	ADT_Radiated_ V7.6.15.9.5	N/A	N/A	N/A
Spectrum Analyzer R&S	FSW43	101582	4/13/2022	4/12/2023
Test Receiver R&S	ESCI	100424	12/30/2021	12/29/2022
Turn Table BV ADT	TT100	TT93021705	N/A	N/A
Turn Table Controller BV ADT	SC100	SC93021705	N/A	N/A

- Note: 1. The calibration interval of the above test instruments is 12 months and the calibrations are traceable to NML/ROC and NIST/USA.
2. The test was performed in HY - 966 chamber 3.

4.1.3 Test Procedures

For Radiated emission below 30MHz

- a. The EUT was placed on the top of a rotating table 0.8 meters above the ground at a 3 meter chamber room. The table was rotated 360 degrees to determine the position of the highest radiation.
- b. The EUT was set 3 meters away from the interference-receiving antenna, which was mounted on the top of a variable-height antenna tower.
- c. Parallel, perpendicular, and ground-parallel orientations of the antenna are set to make the measurement.
- d. For each suspected emission, the EUT was arranged to its worst case and the rotatable table was turned from 0 degrees to 360 degrees to find the maximum reading.
- e. The test-receiver system was set to Quasi-Peak Detect Function and Specified Bandwidth with Maximum Hold Mode.

Note:

1. The resolution bandwidth and video bandwidth of test receiver/spectrum analyzer is 9kHz at frequency below 30MHz.

For Radiated emission above 30MHz

- a. The EUT was placed on the top of a rotating table 0.8 meters (for 30MHz ~ 1GHz) / 1.5 meters (for above 1GHz) above the ground at 3 meter chamber room for test. The table was rotated 360 degrees to determine the position of the highest radiation.
- b. The EUT was set 3 meters away from the interference-receiving antenna, which was mounted on the top of a variable-height antenna tower.
- c. The height of antenna is varied from one meter to four meters above the ground to determine the maximum value of the field strength. Both horizontal and vertical polarizations of the antenna are set to make the measurement.
- d. For each suspected emission, the EUT was arranged to its worst case and then the antenna was tuned to heights from 1 meter to 4 meters and the rotatable table was turned from 0 degrees to 360 degrees to find the maximum reading.
- e. The test-receiver system was set to quasi-peak detect function and specified bandwidth with maximum hold mode when the test frequency is below 1 GHz.
- f. The test-receiver system was set to peak and average detect function and specified bandwidth with maximum hold mode when the test frequency is above 1 GHz. If the peak reading value also meets average limit, measurement with the average detector is unnecessary.

Note:

1. The resolution bandwidth and video bandwidth of test receiver/spectrum analyzer is 120kHz for Quasi-peak detection (QP) at frequency below 1GHz.
2. For WLAN device measurement, the resolution bandwidth of test receiver/spectrum analyzer is 1 MHz and the video bandwidth is 3 MHz for Peak detection (PK) at frequency above 1 GHz. The resolution bandwidth of test receiver/spectrum analyzer is 1MHz and the video bandwidth is $\geq 1/T$ (Duty cycle < 98%) or 10Hz (Duty cycle $\geq 98\%$) for Average detection (AV) at frequency above 1GHz.
3. All modes of operation were investigated and the worst-case emissions are reported.

4.1.4 Deviation from Test Standard

No deviation.

4.1.5 Test Setup

For Radiated emission below 30MHz

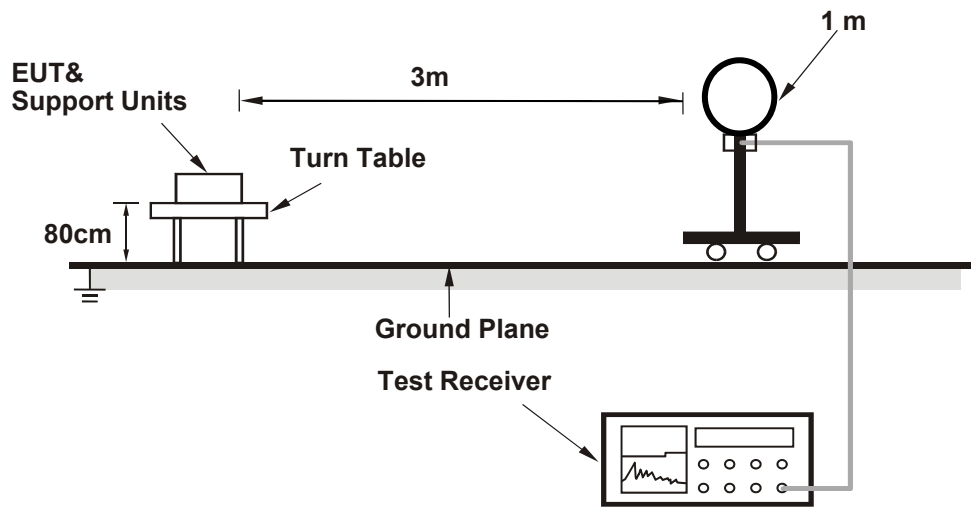

For Radiated emission 30MHz to 1GHz

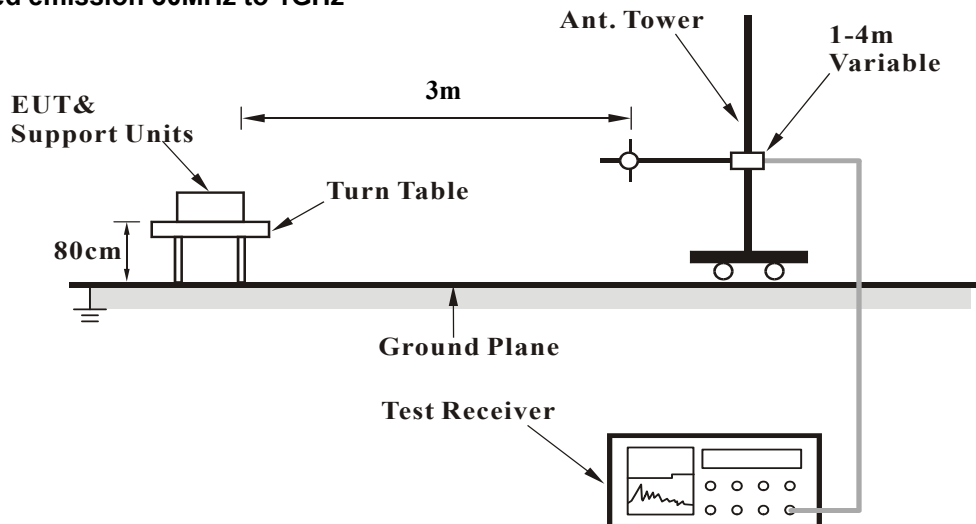

For Radiated emission above 1GHz

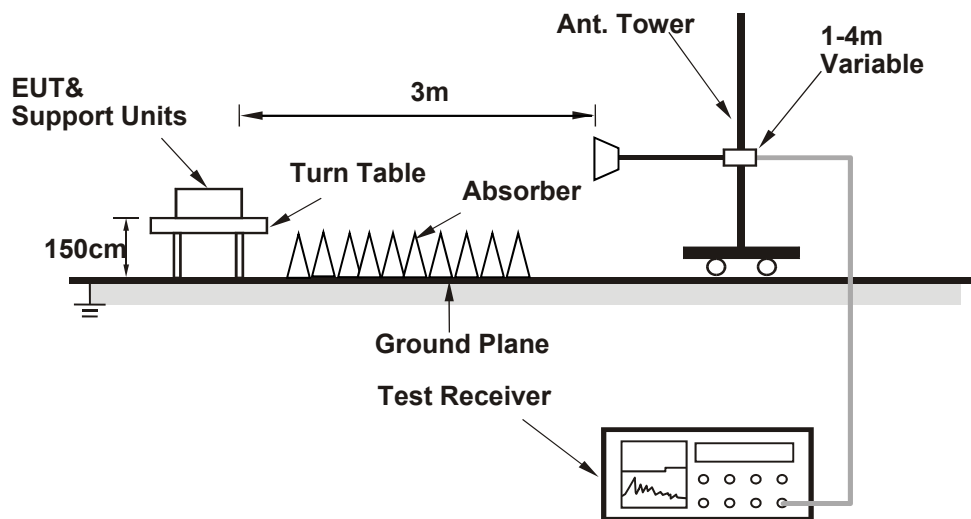

For the actual test configuration, please refer to the attached file (Test Setup Photo).

4.1.6 EUT Operating Conditions

- a. Placed the EUT on the testing table.
- b. Prepared a notebook to act as a communication partner and placed it outside of testing area.
- c. The communication partner connected with EUT via a RJ45 cable and ran a test program (provided by manufacturer) to enable EUT under transmission condition continuously at specific channel frequency.

4.1.7 Test Results

Above 1GHz Data:

RF Mode	TX 802.11b + 802.11ax (HE20)	Channel	CH 6 : 2437 MHz + CH 157 : 5785 MHz
Frequency Range	1 GHz ~ 40 GHz	Detector Function & Bandwidth	(PK) RB = 1 MHz, VB = 3 MHz (AV) RB = 1 MHz, VB = 1 kHz
Input Power	120 Vac, 60 Hz	Environmental Conditions	23°C, 66% RH
Tested By	Titan Hsu		

Antenna Polarity & Test Distance : Horizontal at 3 m								
No	Frequency (MHz)	Emission Level (dBuV/m)	Limit (dBuV/m)	Margin (dB)	Antenna Height (m)	Table Angle (Degree)	Raw Value (dBuV)	Correction Factor (dB/m)
1	*2437.00	113.4 PK			2.82 H	46	78.5	34.9
2	*2437.00	111.1 AV			2.82 H	46	76.2	34.9
3	4874.00	52.0 PK	74.0	-22.0	1.39 H	5	38.5	13.5
4	4874.00	39.0 AV	54.0	-15.0	1.39 H	5	25.5	13.5
5	#5630.80	61.4 PK	68.2	-6.8	2.55 H	341	48.7	12.7
6	*5785.00	122.0 PK			2.55 H	341	78.2	43.8
7	*5785.00	110.9 AV			2.55 H	341	67.1	43.8
8	#5988.00	61.3 PK	68.2	-6.9	2.55 H	341	47.6	13.7
9	11570.00	63.8 PK	74.0	-10.2	2.02 H	159	40.0	23.8
10	11570.00	50.9 AV	54.0	-3.1	2.02 H	159	27.1	23.8
Antenna Polarity & Test Distance : Vertical at 3 m								
No	Frequency (MHz)	Emission Level (dBuV/m)	Limit (dBuV/m)	Margin (dB)	Antenna Height (m)	Table Angle (Degree)	Raw Value (dBuV)	Correction Factor (dB/m)
1	*2437.00	112.0 PK			1.99 V	10	77.1	34.9
2	*2437.00	109.1 AV			1.99 V	10	74.2	34.9
3	4874.00	51.7 PK	74.0	-22.3	1.35 V	205	38.2	13.5
4	4874.00	38.9 AV	54.0	-15.1	1.35 V	205	25.4	13.5
5	#5632.40	61.7 PK	68.2	-6.5	1.46 V	47	49.0	12.7
6	*5785.00	122.9 PK			1.46 V	47	79.1	43.8
7	*5785.00	111.5 AV			1.46 V	47	67.7	43.8
8	#5956.80	62.3 PK	68.2	-5.9	1.46 V	47	48.5	13.8
9	11570.00	64.0 PK	74.0	-10.0	2.02 V	159	40.2	23.8
10	11570.00	51.1 AV	54.0	-2.9	2.02 V	159	27.3	23.8

Remarks:

1. Emission Level(dBuV/m) = Raw Value(dBuV) + Correction Factor(dB/m).
2. Correction Factor(dB/m) = Antenna Factor(dB/m) + Cable Factor(dB) – Pre-Amplifier Factor(dB).
3. Margin value = Emission Level – Limit value.
4. The other emission levels were very low against the limit.
5. " * " : Fundamental frequency, the limit was restricted at the RF Output Power.
6. " # " : The radiated frequency is out of the restricted band.

RF Mode	TX 802.11b + 802.11ax (HE40)	Channel	CH 6 : 2437 MHz + CH 167 : 5835 MHz
Frequency Range	1 GHz ~ 40 GHz	Detector Function & Bandwidth	(PK) RB = 1 MHz, VB = 3 MHz (AV) RB = 1 MHz, VB = 1 kHz
Input Power	120 Vac, 60 Hz	Environmental Conditions	23°C, 66% RH
Tested By	Titan Hsu		

Antenna Polarity & Test Distance : Horizontal at 3 m								
No	Frequency (MHz)	Emission Level (dBuV/m)	Limit (dBuV/m)	Margin (dB)	Antenna Height (m)	Table Angle (Degree)	Raw Value (dBuV)	Correction Factor (dB/m)
1	*2437.00	113.1 PK			2.85 H	48	78.2	34.9
2	*2437.00	110.9 AV			2.85 H	48	76.0	34.9
3	4874.00	52.1 PK	74.0	-21.9	1.45 H	7	38.6	13.5
4	4874.00	39.1 AV	54.0	-14.9	1.45 H	7	25.6	13.5
5	*5835.00	121.1 PK			2.58 H	352	77.1	44.0
6	*5835.00	109.0 AV			2.58 H	352	65.0	44.0
7	#5900.55	84.2 PK	106.1	-21.9	2.58 H	352	70.5	13.7
8	#5927.15	77.0 PK	88.2	-11.2	2.58 H	352	63.2	13.8
9	11670.00	65.2 PK	74.0	-8.8	1.82 H	256	42.0	23.2
10	11670.00	50.4 AV	54.0	-3.6	1.82 H	256	27.2	23.2
Antenna Polarity & Test Distance : Vertical at 3 m								
No	Frequency (MHz)	Emission Level (dBuV/m)	Limit (dBuV/m)	Margin (dB)	Antenna Height (m)	Table Angle (Degree)	Raw Value (dBuV)	Correction Factor (dB/m)
1	*2437.00	111.7 PK			1.95 V	12	76.8	34.9
2	*2437.00	109.0 AV			1.95 V	12	74.1	34.9
3	4874.00	51.8 PK	74.0	-22.2	1.38 V	202	38.3	13.5
4	4874.00	39.0 AV	54.0	-15.0	1.38 V	202	25.5	13.5
5	*5835.00	122.5 PK			1.37 V	26	78.5	44.0
6	*5835.00	110.3 AV			1.37 V	26	66.3	44.0
7	#5901.02	85.8 PK	105.8	-20.0	1.37 V	26	72.1	13.7
8	#5925.73	78.8 PK	88.2	-9.4	1.37 V	26	65.0	13.8
9	11670.00	65.4 PK	74.0	-8.6	2.25 V	308	42.2	23.2
10	11670.00	50.7 AV	54.0	-3.3	2.25 V	308	27.5	23.2

Remarks:

1. Emission Level(dBuV/m) = Raw Value(dBuV) + Correction Factor(dB/m).
2. Correction Factor(dB/m) = Antenna Factor(dB/m) + Cable Factor(dB) – Pre-Amplifier Factor(dB).
3. Margin value = Emission Level – Limit value.
4. The other emission levels were very low against the limit.
5. " * " : Fundamental frequency, the limit was restricted at the RF Output Power.
6. " # " : The radiated frequency is out of the restricted band.

Below 1GHz data

RF Mode	TX 802.11b + 802.11ax (HE20)	Channel	CH 6 : 2437 MHz + CH 157 : 5785 MHz
Frequency Range	30 MHz ~ 1 GHz	Detector Function & Bandwidth	(QP) RB = 120kHz
Input Power	120 Vac, 60 Hz	Environmental Conditions	23°C, 66% RH
Tested By	Titan Hsu	Test Mode	A

Antenna Polarity & Test Distance : Horizontal at 3 m								
No	Frequency (MHz)	Emission Level (dBuV/m)	Limit (dBuV/m)	Margin (dB)	Antenna Height (m)	Table Angle (Degree)	Raw Value (dBuV)	Correction Factor (dB/m)
1	61.04	36.6 QP	40.0	-3.4	1.49 H	226	46.0	-9.4
2	101.78	37.1 QP	43.5	-6.4	1.00 H	271	50.1	-13.0
3	163.86	31.9 QP	43.5	-11.6	1.49 H	255	40.6	-8.7
4	741.98	38.8 QP	46.0	-7.2	1.00 H	9	37.4	1.4
5	773.02	33.4 QP	46.0	-12.6	1.00 H	31	31.1	2.3
6	939.86	35.9 QP	46.0	-10.1	1.49 H	291	29.9	6.0

Remarks:

1. Emission Level(dBuV/m) = Raw Value(dBuV) + Correction Factor(dB/m).
2. Correction Factor(dB/m) = Antenna Factor(dB/m) + Cable Factor(dB) – Pre-Amplifier Factor(dB).
3. Margin value = Emission Level – Limit value.
4. The other emission levels were very low against the limit of frequency range 30 MHz ~ 1 GHz.
5. The emission levels were very low against the limit of frequency range 9 kHz ~ 30 MHz: the amplitude of spurious emissions attenuated more than 20 dB below the permissible value to be report.

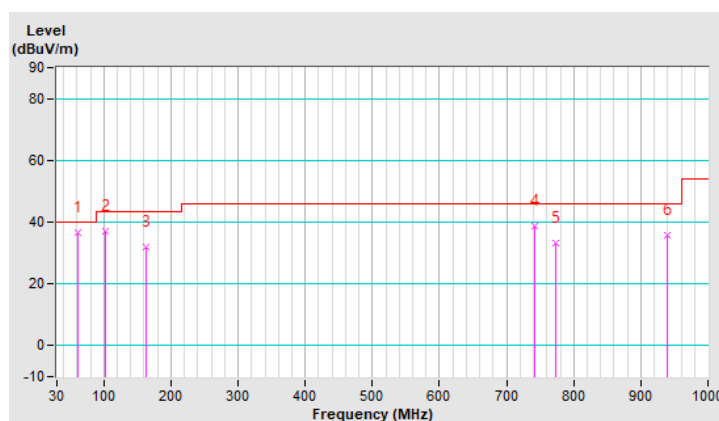

RF Mode	TX 802.11b + 802.11ax (HE20)	Channel	CH 6 : 2437 MHz + CH 157 : 5785 MHz
Frequency Range	30 MHz ~ 1 GHz	Detector Function & Bandwidth	(QP) RB = 120kHz
Input Power	120 Vac, 60 Hz	Environmental Conditions	23°C, 66% RH
Tested By	Titan Hsu	Test Mode	A

Antenna Polarity & Test Distance : Vertical at 3 m								
No	Frequency (MHz)	Emission Level (dBuV/m)	Limit (dBuV/m)	Margin (dB)	Antenna Height (m)	Table Angle (Degree)	Raw Value (dBuV)	Correction Factor (dB/m)
1	76.56	36.6 QP	40.0	-3.4	1.99 V	134	48.7	-12.1
2	128.94	35.4 QP	43.5	-8.1	1.49 V	16	45.4	-10.0
3	194.90	36.4 QP	43.5	-7.1	1.00 V	71	47.7	-11.3
4	291.90	37.8 QP	46.0	-8.2	1.49 V	60	45.5	-7.7
5	567.38	36.4 QP	46.0	-9.6	1.49 V	162	39.4	-3.0
6	730.34	37.6 QP	46.0	-8.4	1.00 V	53	36.6	1.0

Remarks:

1. Emission Level(dBuV/m) = Raw Value(dBuV) + Correction Factor(dB/m).
2. Correction Factor(dB/m) = Antenna Factor(dB/m) + Cable Factor(dB) – Pre-Amplifier Factor(dB).
3. Margin value = Emission Level – Limit value.
4. The other emission levels were very low against the limit of frequency range 30 MHz ~ 1 GHz.
5. The emission levels were very low against the limit of frequency range 9 kHz ~ 30 MHz: the amplitude of spurious emissions attenuated more than 20 dB below the permissible value to be report.

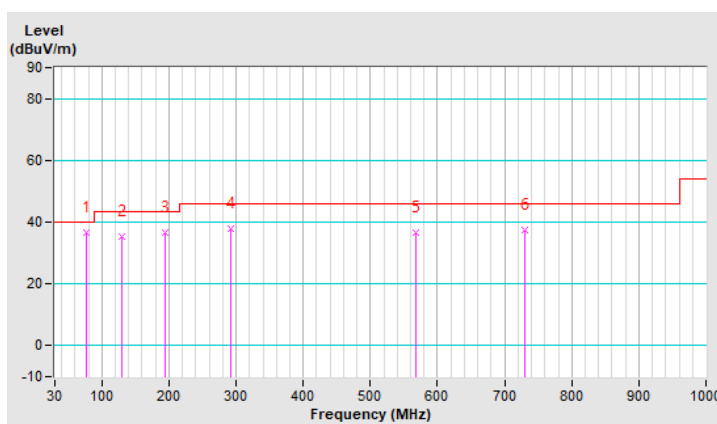

RF Mode	TX 802.11b + 802.11ax (HE20)	Channel	CH 6 : 2437 MHz + CH 157 : 5785 MHz
Frequency Range	30 MHz ~ 1 GHz	Detector Function & Bandwidth	(QP) RB = 120kHz
Input Power	120 Vac, 60 Hz	Environmental Conditions	23°C, 66% RH
Tested By	Titan Hsu	Test Mode	B

Antenna Polarity & Test Distance : Horizontal at 3 m								
No	Frequency (MHz)	Emission Level (dBuV/m)	Limit (dBuV/m)	Margin (dB)	Antenna Height (m)	Table Angle (Degree)	Raw Value (dBuV)	Correction Factor (dB/m)
1	99.84	36.1 QP	43.5	-7.4	1.01 H	113	49.4	-13.3
2	165.80	30.1 QP	43.5	-13.4	1.50 H	191	38.8	-8.7
3	381.14	28.0 QP	46.0	-18.0	1.01 H	20	34.0	-6.0
4	714.82	39.5 QP	46.0	-6.5	1.01 H	106	39.2	0.3
5	776.90	33.6 QP	46.0	-12.4	1.01 H	6	31.2	2.4
6	982.54	33.0 QP	54.0	-21.0	1.50 H	305	26.4	6.6

Remarks:

1. Emission Level(dBuV/m) = Raw Value(dBuV) + Correction Factor(dB/m).
2. Correction Factor(dB/m) = Antenna Factor(dB/m) + Cable Factor(dB) – Pre-Amplifier Factor(dB).
3. Margin value = Emission Level – Limit value.
4. The other emission levels were very low against the limit of frequency range 30 MHz ~ 1 GHz.
5. The emission levels were very low against the limit of frequency range 9 kHz ~ 30 MHz: the amplitude of spurious emissions attenuated more than 20 dB below the permissible value to be report.

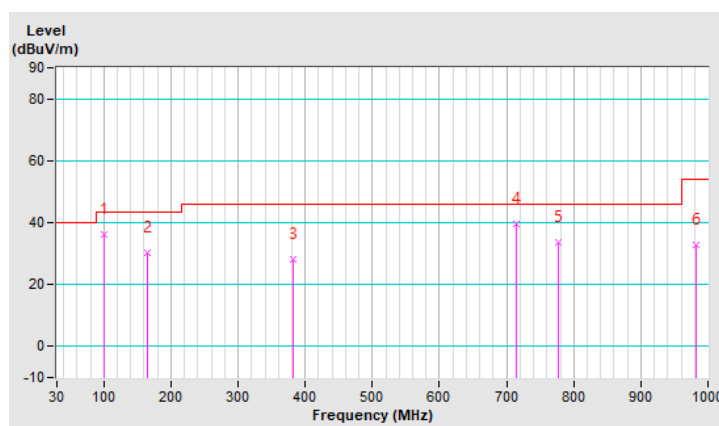

RF Mode	TX 802.11b + 802.11ax (HE20)	Channel	CH 6 : 2437 MHz + CH 157 : 5785 MHz
Frequency Range	30 MHz ~ 1 GHz	Detector Function & Bandwidth	(QP) RB = 120kHz
Input Power	120 Vac, 60 Hz	Environmental Conditions	23°C, 66% RH
Tested By	Titan Hsu	Test Mode	B

Antenna Polarity & Test Distance : Vertical at 3 m								
No	Frequency (MHz)	Emission Level (dBuV/m)	Limit (dBuV/m)	Margin (dB)	Antenna Height (m)	Table Angle (Degree)	Raw Value (dBuV)	Correction Factor (dB/m)
1	80.44	34.3 QP	40.0	-5.7	1.99 V	91	47.4	-13.1
2	138.64	35.3 QP	43.5	-8.2	1.49 V	132	44.5	-9.2
3	177.44	35.9 QP	43.5	-7.6	1.00 V	37	45.5	-9.6
4	253.10	40.0 QP	46.0	-6.0	1.49 V	143	49.1	-9.1
5	416.06	34.7 QP	46.0	-11.3	1.00 V	10	40.3	-5.6
6	724.52	38.6 QP	46.0	-7.4	1.99 V	90	37.8	0.8

Remarks:

1. Emission Level(dBuV/m) = Raw Value(dBuV) + Correction Factor(dB/m).
2. Correction Factor(dB/m) = Antenna Factor(dB/m) + Cable Factor(dB) – Pre-Amplifier Factor(dB).
3. Margin value = Emission Level – Limit value.
4. The other emission levels were very low against the limit of frequency range 30 MHz ~ 1 GHz.
5. The emission levels were very low against the limit of frequency range 9 kHz ~ 30 MHz: the amplitude of spurious emissions attenuated more than 20 dB below the permissible value to be report.

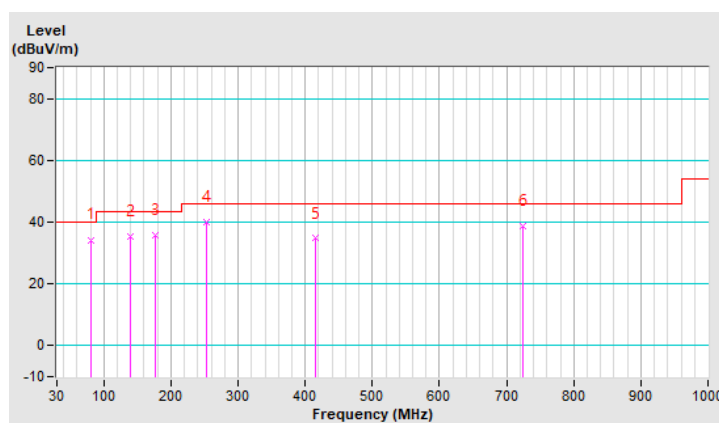

RF Mode	TX 802.11b + 802.11ax (HE20)	Channel	CH 6 : 2437 MHz + CH 157 : 5785 MHz
Frequency Range	30 MHz ~ 1 GHz	Detector Function & Bandwidth	(QP) RB = 120kHz
Input Power	120 Vac, 60 Hz	Environmental Conditions	23°C, 66% RH
Tested By	Titan Hsu	Test Mode	C

Antenna Polarity & Test Distance : Horizontal at 3 m								
No	Frequency (MHz)	Emission Level (dBuV/m)	Limit (dBuV/m)	Margin (dB)	Antenna Height (m)	Table Angle (Degree)	Raw Value (dBuV)	Correction Factor (dB/m)
1	101.78	36.9 QP	43.5	-6.6	1.01 H	313	49.9	-13.0
2	113.42	32.4 QP	43.5	-11.1	1.01 H	291	43.8	-11.4
3	169.68	32.1 QP	43.5	-11.4	1.01 H	132	41.1	-9.0
4	247.28	29.9 QP	46.0	-16.1	1.50 H	91	39.1	-9.2
5	730.34	35.9 QP	46.0	-10.1	1.01 H	16	34.9	1.0
6	932.10	36.6 QP	46.0	-9.4	1.01 H	16	30.9	5.7

Remarks:

1. Emission Level(dBuV/m) = Raw Value(dBuV) + Correction Factor(dB/m).
2. Correction Factor(dB/m) = Antenna Factor(dB/m) + Cable Factor(dB) – Pre-Amplifier Factor(dB).
3. Margin value = Emission Level – Limit value.
4. The other emission levels were very low against the limit of frequency range 30 MHz ~ 1 GHz.
5. The emission levels were very low against the limit of frequency range 9 kHz ~ 30 MHz: the amplitude of spurious emissions attenuated more than 20 dB below the permissible value to be report.

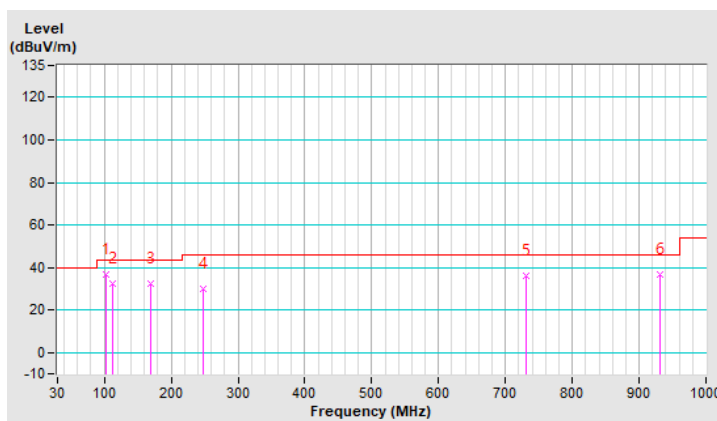

RF Mode	TX 802.11b + 802.11ax (HE20)	Channel	CH 6 : 2437 MHz + CH 157 : 5785 MHz
Frequency Range	30 MHz ~ 1 GHz	Detector Function & Bandwidth	(QP) RB = 120kHz
Input Power	120 Vac, 60 Hz	Environmental Conditions	23°C, 66% RH
Tested By	Titan Hsu	Test Mode	C

Antenna Polarity & Test Distance : Vertical at 3 m								
No	Frequency (MHz)	Emission Level (dBuV/m)	Limit (dBuV/m)	Margin (dB)	Antenna Height (m)	Table Angle (Degree)	Raw Value (dBuV)	Correction Factor (dB/m)
1	47.46	34.4 QP	40.0	-5.6	1.00 V	155	43.3	-8.9
2	95.96	37.2 QP	43.5	-6.3	1.49 V	36	51.3	-14.1
3	138.64	36.0 QP	43.5	-7.5	1.99 V	154	45.2	-9.2
4	233.70	37.7 QP	46.0	-8.3	1.00 V	134	48.0	-10.3
5	330.70	35.8 QP	46.0	-10.2	1.99 V	152	42.4	-6.6
6	483.96	35.1 QP	46.0	-10.9	1.49 V	32	39.6	-4.5

Remarks:

1. Emission Level(dBuV/m) = Raw Value(dBuV) + Correction Factor(dB/m).
2. Correction Factor(dB/m) = Antenna Factor(dB/m) + Cable Factor(dB) – Pre-Amplifier Factor(dB).
3. Margin value = Emission Level – Limit value.
4. The other emission levels were very low against the limit of frequency range 30 MHz ~ 1 GHz.
5. The emission levels were very low against the limit of frequency range 9 kHz ~ 30 MHz: the amplitude of spurious emissions attenuated more than 20 dB below the permissible value to be report.

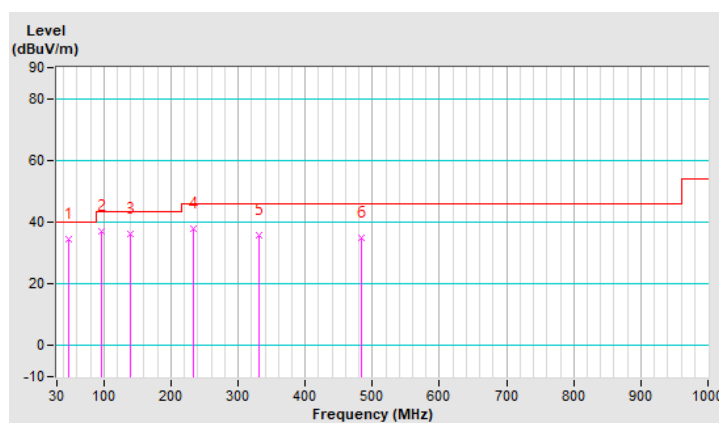

RF Mode	TX 802.11b + 802.11ax (HE20)	Channel	CH 6 : 2437 MHz + CH 157 : 5785 MHz
Frequency Range	30 MHz ~ 1 GHz	Detector Function & Bandwidth	(QP) RB = 120kHz
Input Power	55.5 Vdc	Environmental Conditions	23°C, 66% RH
Tested By	Titan Hsu	Test Mode	D

Antenna Polarity & Test Distance : Horizontal at 3 m								
No	Frequency (MHz)	Emission Level (dBuV/m)	Limit (dBuV/m)	Margin (dB)	Antenna Height (m)	Table Angle (Degree)	Raw Value (dBuV)	Correction Factor (dB/m)
1	90.14	36.5 QP	43.5	-7.0	1.00 H	18	50.8	-14.3
2	138.64	30.9 QP	43.5	-12.6	1.49 H	330	40.1	-9.2
3	177.44	30.5 QP	43.5	-13.0	1.00 H	154	40.1	-9.6
4	732.28	32.2 QP	46.0	-13.8	1.00 H	184	31.2	1.0
5	773.02	33.6 QP	46.0	-12.4	1.00 H	353	31.3	2.3
6	932.10	37.2 QP	46.0	-8.8	1.00 H	3	31.5	5.7

Remarks:

1. Emission Level(dBuV/m) = Raw Value(dBuV) + Correction Factor(dB/m).
2. Correction Factor(dB/m) = Antenna Factor(dB/m) + Cable Factor(dB) – Pre-Amplifier Factor(dB).
3. Margin value = Emission Level – Limit value.
4. The other emission levels were very low against the limit of frequency range 30 MHz ~ 1 GHz.
5. The emission levels were very low against the limit of frequency range 9 kHz ~ 30 MHz: the amplitude of spurious emissions attenuated more than 20 dB below the permissible value to be report.

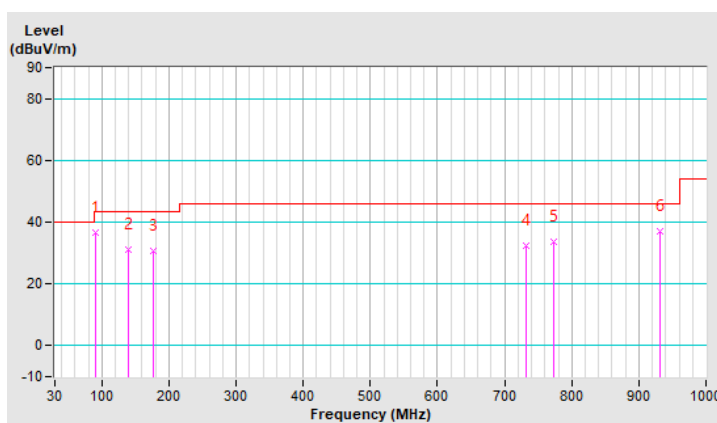

RF Mode	TX 802.11b + 802.11ax (HE20)	Channel	CH 6 : 2437 MHz + CH 157 : 5785 MHz
Frequency Range	30 MHz ~ 1 GHz	Detector Function & Bandwidth	(QP) RB = 120kHz
Input Power	55.5 Vdc	Environmental Conditions	23°C, 66% RH
Tested By	Titan Hsu	Test Mode	D

Antenna Polarity & Test Distance : Vertical at 3 m								
No	Frequency (MHz)	Emission Level (dBuV/m)	Limit (dBuV/m)	Margin (dB)	Antenna Height (m)	Table Angle (Degree)	Raw Value (dBuV)	Correction Factor (dB/m)
1	72.68	33.0 QP	40.0	-7.0	1.01 V	157	44.2	-11.2
2	130.88	33.6 QP	43.5	-9.9	1.01 V	195	43.5	-9.9
3	183.26	34.9 QP	43.5	-8.6	1.01 V	41	45.3	-10.4
4	239.52	36.6 QP	46.0	-9.4	1.01 V	188	46.2	-9.6
5	491.72	35.1 QP	46.0	-10.9	1.01 V	103	39.6	-4.5
6	588.72	33.6 QP	46.0	-12.4	1.01 V	100	35.8	-2.2

Remarks:

1. Emission Level(dBuV/m) = Raw Value(dBuV) + Correction Factor(dB/m).
2. Correction Factor(dB/m) = Antenna Factor(dB/m) + Cable Factor(dB) – Pre-Amplifier Factor(dB).
3. Margin value = Emission Level – Limit value.
4. The other emission levels were very low against the limit of frequency range 30 MHz ~ 1 GHz.
5. The emission levels were very low against the limit of frequency range 9 kHz ~ 30 MHz: the amplitude of spurious emissions attenuated more than 20 dB below the permissible value to be report.

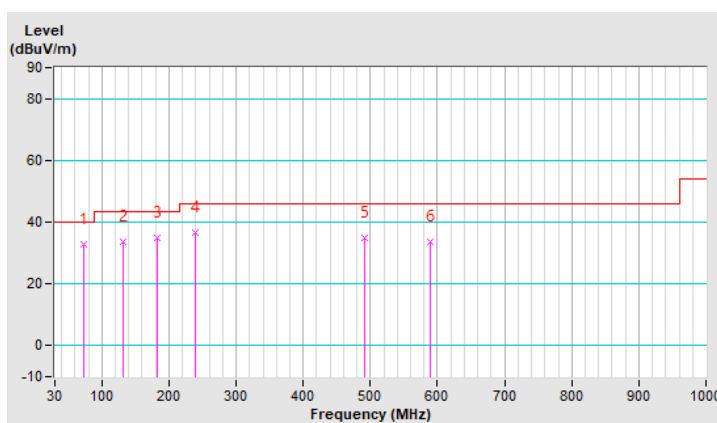

RF Mode	TX 802.11b + 802.11ax (HE40)	Channel	CH 6 : 2437 MHz + CH 167 : 5835 MHz
Frequency Range	30 MHz ~ 1 GHz	Detector Function & Bandwidth	(QP) RB = 120kHz
Input Power	120 Vac, 60 Hz	Environmental Conditions	23°C, 66% RH
Tested By	Titan Hsu	Test Mode	A

Antenna Polarity & Test Distance : Horizontal at 3 m								
No	Frequency (MHz)	Emission Level (dBuV/m)	Limit (dBuV/m)	Margin (dB)	Antenna Height (m)	Table Angle (Degree)	Raw Value (dBuV)	Correction Factor (dB/m)
1	101.78	36.8 QP	43.5	-6.7	1.00 H	73	49.8	-13.0
2	144.46	34.4 QP	43.5	-9.1	1.99 H	120	43.2	-8.8
3	187.14	30.6 QP	43.5	-12.9	1.99 H	157	41.3	-10.7
4	276.38	27.3 QP	46.0	-18.7	1.50 H	102	35.2	-7.9
5	687.66	34.0 QP	46.0	-12.0	1.50 H	129	34.3	-0.3
6	722.58	33.2 QP	46.0	-12.8	1.50 H	107	32.5	0.7

Remarks:

1. Emission Level(dBuV/m) = Raw Value(dBuV) + Correction Factor(dB/m).
2. Correction Factor(dB/m) = Antenna Factor(dB/m) + Cable Factor(dB) – Pre-Amplifier Factor(dB).
3. Margin value = Emission Level – Limit value.
4. The other emission levels were very low against the limit of frequency range 30 MHz ~ 1 GHz.
5. The emission levels were very low against the limit of frequency range 9 kHz ~ 30 MHz: the amplitude of spurious emissions attenuated more than 20 dB below the permissible value to be report.

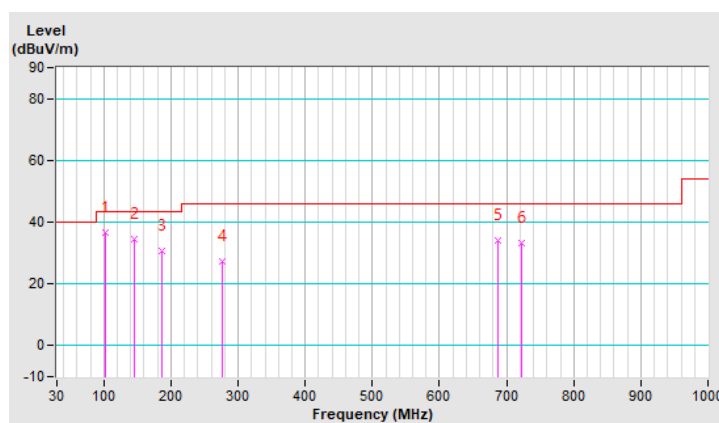

RF Mode	TX 802.11b + 802.11ax (HE40)	Channel	CH 6 : 2437 MHz + CH 167 : 5835 MHz
Frequency Range	30 MHz ~ 1 GHz	Detector Function & Bandwidth	(QP) RB = 120kHz
Input Power	120 Vac, 60 Hz	Environmental Conditions	23°C, 66% RH
Tested By	Titan Hsu	Test Mode	A

Antenna Polarity & Test Distance : Vertical at 3 m								
No	Frequency (MHz)	Emission Level (dBuV/m)	Limit (dBuV/m)	Margin (dB)	Antenna Height (m)	Table Angle (Degree)	Raw Value (dBuV)	Correction Factor (dB/m)
1	70.74	33.9 QP	40.0	-6.1	1.49 V	127	44.8	-10.9
2	101.78	35.3 QP	43.5	-8.2	1.49 V	71	48.3	-13.0
3	222.06	40.1 QP	46.0	-5.9	1.49 V	69	51.2	-11.1
4	322.94	37.1 QP	46.0	-8.9	1.49 V	69	44.0	-6.9
5	379.20	33.2 QP	46.0	-12.8	1.49 V	162	39.2	-6.0
6	730.34	35.0 QP	46.0	-11.0	1.00 V	230	34.0	1.0

Remarks:

1. Emission Level(dBuV/m) = Raw Value(dBuV) + Correction Factor(dB/m).
2. Correction Factor(dB/m) = Antenna Factor(dB/m) + Cable Factor(dB) – Pre-Amplifier Factor(dB).
3. Margin value = Emission Level – Limit value.
4. The other emission levels were very low against the limit of frequency range 30 MHz ~ 1 GHz.
5. The emission levels were very low against the limit of frequency range 9 kHz ~ 30 MHz: the amplitude of spurious emissions attenuated more than 20 dB below the permissible value to be report.

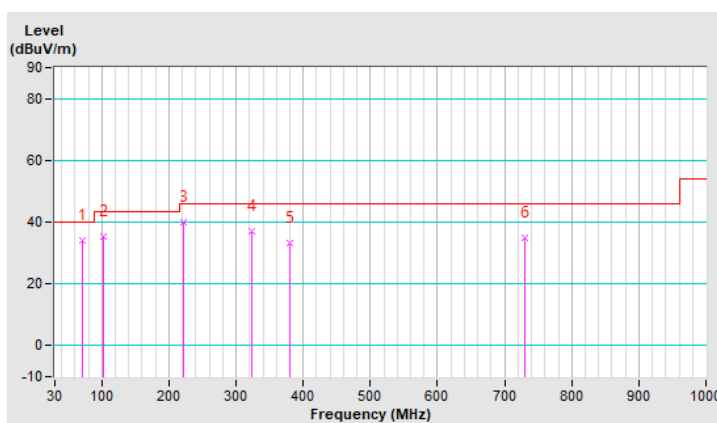

RF Mode	TX 802.11b + 802.11ax (HE40)	Channel	CH 6 : 2437 MHz + CH 167 : 5835 MHz
Frequency Range	30 MHz ~ 1 GHz	Detector Function & Bandwidth	(QP) RB = 120kHz
Input Power	120 Vac, 60 Hz	Environmental Conditions	23°C, 66% RH
Tested By	Titan Hsu	Test Mode	B

Antenna Polarity & Test Distance : Horizontal at 3 m								
No	Frequency (MHz)	Emission Level (dBuV/m)	Limit (dBuV/m)	Margin (dB)	Antenna Height (m)	Table Angle (Degree)	Raw Value (dBuV)	Correction Factor (dB/m)
1	35.82	33.1 QP	40.0	-6.9	1.49 H	81	43.1	-10.0
2	88.20	37.6 QP	43.5	-5.9	1.00 H	177	51.9	-14.3
3	150.28	29.5 QP	43.5	-14.0	1.49 H	5	38.0	-8.5
4	330.70	25.1 QP	46.0	-20.9	1.49 H	5	31.7	-6.6
5	740.04	31.4 QP	46.0	-14.6	1.00 H	97	30.1	1.3
6	949.56	35.3 QP	46.0	-10.7	1.49 H	5	29.2	6.1

Remarks:

1. Emission Level(dBuV/m) = Raw Value(dBuV) + Correction Factor(dB/m).
2. Correction Factor(dB/m) = Antenna Factor(dB/m) + Cable Factor(dB) – Pre-Amplifier Factor(dB).
3. Margin value = Emission Level – Limit value.
4. The other emission levels were very low against the limit of frequency range 30 MHz ~ 1 GHz.
5. The emission levels were very low against the limit of frequency range 9 kHz ~ 30 MHz: the amplitude of spurious emissions attenuated more than 20 dB below the permissible value to be report.

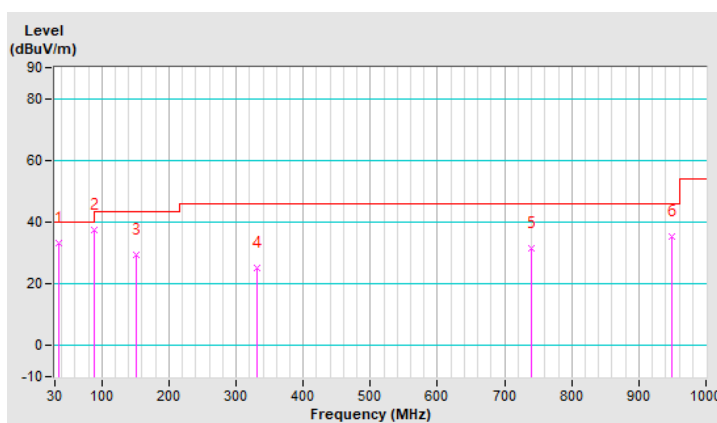

RF Mode	TX 802.11b + 802.11ax (HE40)	Channel	CH 6 : 2437 MHz + CH 167 : 5835 MHz
Frequency Range	30 MHz ~ 1 GHz	Detector Function & Bandwidth	(QP) RB = 120kHz
Input Power	120 Vac, 60 Hz	Environmental Conditions	23°C, 66% RH
Tested By	Titan Hsu	Test Mode	B

Antenna Polarity & Test Distance : Vertical at 3 m								
No	Frequency (MHz)	Emission Level (dBuV/m)	Limit (dBuV/m)	Margin (dB)	Antenna Height (m)	Table Angle (Degree)	Raw Value (dBuV)	Correction Factor (dB/m)
1	72.68	33.1 QP	40.0	-6.9	1.01 V	16	44.3	-11.2
2	210.42	39.1 QP	43.5	-4.4	1.01 V	139	50.4	-11.3
3	241.46	36.3 QP	46.0	-9.7	1.01 V	148	45.8	-9.5
4	303.54	34.8 QP	46.0	-11.2	1.01 V	106	42.1	-7.3
5	557.68	32.9 QP	46.0	-13.1	1.01 V	128	36.1	-3.2
6	724.52	36.4 QP	46.0	-9.6	1.01 V	16	35.6	0.8

Remarks:

1. Emission Level(dBuV/m) = Raw Value(dBuV) + Correction Factor(dB/m).
2. Correction Factor(dB/m) = Antenna Factor(dB/m) + Cable Factor(dB) – Pre-Amplifier Factor(dB).
3. Margin value = Emission Level – Limit value.
4. The other emission levels were very low against the limit of frequency range 30 MHz ~ 1 GHz.
5. The emission levels were very low against the limit of frequency range 9 kHz ~ 30 MHz: the amplitude of spurious emissions attenuated more than 20 dB below the permissible value to be report.

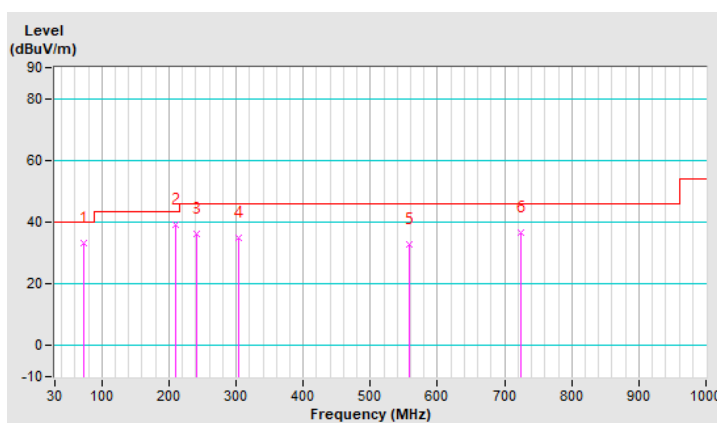

RF Mode	TX 802.11b + 802.11ax (HE40)	Channel	CH 6 : 2437 MHz + CH 167 : 5835 MHz
Frequency Range	30 MHz ~ 1 GHz	Detector Function & Bandwidth	(QP) RB = 120kHz
Input Power	120 Vac, 60 Hz	Environmental Conditions	23°C, 66% RH
Tested By	Titan Hsu	Test Mode	C

Antenna Polarity & Test Distance : Horizontal at 3 m								
No	Frequency (MHz)	Emission Level (dBuV/m)	Limit (dBuV/m)	Margin (dB)	Antenna Height (m)	Table Angle (Degree)	Raw Value (dBuV)	Correction Factor (dB/m)
1	101.78	36.5 QP	43.5	-7.0	1.00 H	266	49.5	-13.0
2	113.42	32.6 QP	43.5	-10.9	1.49 H	162	44.0	-11.4
3	192.96	34.8 QP	43.5	-8.7	1.49 H	180	46.2	-11.4
4	286.08	29.0 QP	46.0	-17.0	1.00 H	82	36.7	-7.7
5	776.90	34.0 QP	46.0	-12.0	1.00 H	118	31.6	2.4
6	939.86	38.4 QP	46.0	-7.6	1.49 H	110	32.4	6.0

Remarks:

1. Emission Level(dBuV/m) = Raw Value(dBuV) + Correction Factor(dB/m).
2. Correction Factor(dB/m) = Antenna Factor(dB/m) + Cable Factor(dB) – Pre-Amplifier Factor(dB).
3. Margin value = Emission Level – Limit value.
4. The other emission levels were very low against the limit of frequency range 30 MHz ~ 1 GHz.
5. The emission levels were very low against the limit of frequency range 9 kHz ~ 30 MHz: the amplitude of spurious emissions attenuated more than 20 dB below the permissible value to be report.

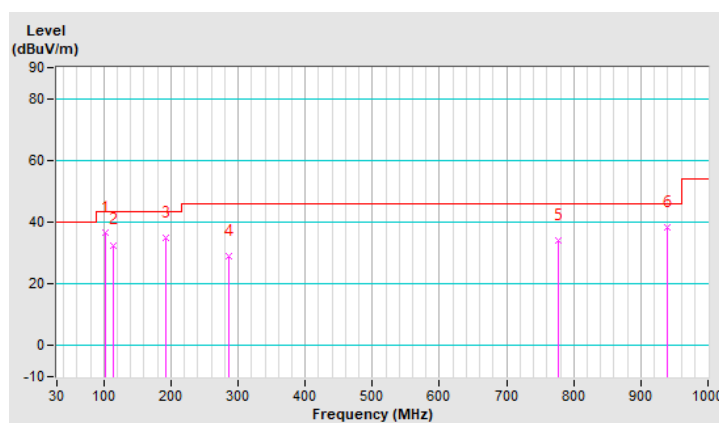

RF Mode	TX 802.11b + 802.11ax (HE40)	Channel	CH 6 : 2437 MHz + CH 167 : 5835 MHz
Frequency Range	30 MHz ~ 1 GHz	Detector Function & Bandwidth	(QP) RB = 120kHz
Input Power	120 Vac, 60 Hz	Environmental Conditions	23°C, 66% RH
Tested By	Titan Hsu	Test Mode	C

Antenna Polarity & Test Distance : Vertical at 3 m								
No	Frequency (MHz)	Emission Level (dBuV/m)	Limit (dBuV/m)	Margin (dB)	Antenna Height (m)	Table Angle (Degree)	Raw Value (dBuV)	Correction Factor (dB/m)
1	66.86	32.7 QP	40.0	-7.3	1.01 V	10	42.8	-10.1
2	225.94	38.0 QP	46.0	-8.0	1.01 V	30	49.2	-11.2
3	272.50	36.9 QP	46.0	-9.1	1.01 V	122	45.1	-8.2
4	346.22	35.2 QP	46.0	-10.8	1.01 V	134	42.0	-6.8
5	406.36	35.4 QP	46.0	-10.6	1.01 V	128	41.3	-5.9
6	730.34	41.1 QP	46.0	-4.9	1.01 V	181	40.1	1.0

Remarks:

1. Emission Level(dBuV/m) = Raw Value(dBuV) + Correction Factor(dB/m).
2. Correction Factor(dB/m) = Antenna Factor(dB/m) + Cable Factor(dB) – Pre-Amplifier Factor(dB).
3. Margin value = Emission Level – Limit value.
4. The other emission levels were very low against the limit of frequency range 30 MHz ~ 1 GHz.
5. The emission levels were very low against the limit of frequency range 9 kHz ~ 30 MHz: the amplitude of spurious emissions attenuated more than 20 dB below the permissible value to be report.

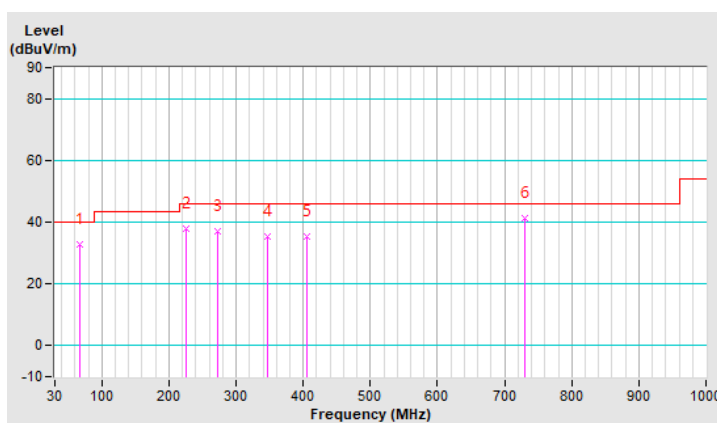

RF Mode	TX 802.11b + 802.11ax (HE40)	Channel	CH 6 : 2437 MHz + CH 167 : 5835 MHz
Frequency Range	30 MHz ~ 1 GHz	Detector Function & Bandwidth	(QP) RB = 120kHz
Input Power	55.5 Vdc	Environmental Conditions	23°C, 66% RH
Tested By	Titan Hsu	Test Mode	D

Antenna Polarity & Test Distance : Horizontal at 3 m								
No	Frequency (MHz)	Emission Level (dBuV/m)	Limit (dBuV/m)	Margin (dB)	Antenna Height (m)	Table Angle (Degree)	Raw Value (dBuV)	Correction Factor (dB/m)
1	51.34	36.2 QP	40.0	-3.8	1.50 H	132	45.0	-8.8
2	101.78	36.5 QP	43.5	-7.0	1.00 H	93	49.5	-13.0
3	192.96	30.6 QP	43.5	-12.9	1.50 H	144	42.0	-11.4
4	613.94	29.5 QP	46.0	-16.5	1.50 H	144	30.8	-1.3
5	722.58	34.9 QP	46.0	-11.1	1.50 H	221	34.2	0.7
6	932.10	37.6 QP	46.0	-8.4	1.00 H	6	31.9	5.7

Remarks:

1. Emission Level(dBuV/m) = Raw Value(dBuV) + Correction Factor(dB/m).
2. Correction Factor(dB/m) = Antenna Factor(dB/m) + Cable Factor(dB) – Pre-Amplifier Factor(dB).
3. Margin value = Emission Level – Limit value.
4. The other emission levels were very low against the limit of frequency range 30 MHz ~ 1 GHz.
5. The emission levels were very low against the limit of frequency range 9 kHz ~ 30 MHz: the amplitude of spurious emissions attenuated more than 20 dB below the permissible value to be report.

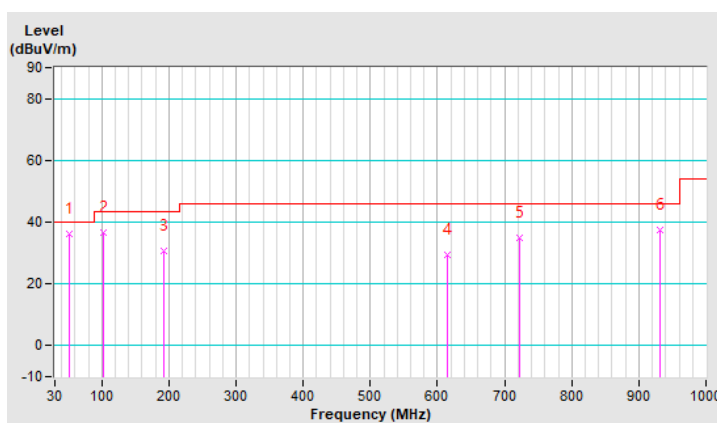

RF Mode	TX 802.11b + 802.11ax (HE40)	Channel	CH 6 : 2437 MHz + CH 167 : 5835 MHz
Frequency Range	30 MHz ~ 1 GHz	Detector Function & Bandwidth	(QP) RB = 120kHz
Input Power	55.5 Vdc	Environmental Conditions	23°C, 66% RH
Tested By	Titan Hsu	Test Mode	D

Antenna Polarity & Test Distance : Vertical at 3 m								
No	Frequency (MHz)	Emission Level (dBuV/m)	Limit (dBuV/m)	Margin (dB)	Antenna Height (m)	Table Angle (Degree)	Raw Value (dBuV)	Correction Factor (dB/m)
1	72.68	34.1 QP	40.0	-5.9	1.49 V	88	45.3	-11.2
2	132.82	32.7 QP	43.5	-10.8	1.49 V	170	42.4	-9.7
3	266.68	37.4 QP	46.0	-8.6	1.49 V	163	45.9	-8.5
4	284.14	34.6 QP	46.0	-11.4	1.49 V	166	42.3	-7.7
5	582.90	32.5 QP	46.0	-13.5	1.49 V	187	34.9	-2.4
6	730.34	38.6 QP	46.0	-7.4	1.00 V	159	37.6	1.0

Remarks:

1. Emission Level(dBuV/m) = Raw Value(dBuV) + Correction Factor(dB/m).
2. Correction Factor(dB/m) = Antenna Factor(dB/m) + Cable Factor(dB) – Pre-Amplifier Factor(dB).
3. Margin value = Emission Level – Limit value.
4. The other emission levels were very low against the limit of frequency range 30 MHz ~ 1 GHz.
5. The emission levels were very low against the limit of frequency range 9 kHz ~ 30 MHz: the amplitude of spurious emissions attenuated more than 20 dB below the permissible value to be report.

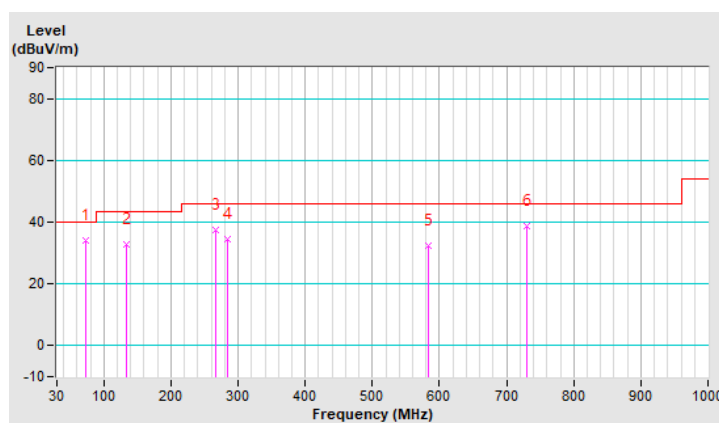

4.2 Conducted Out of Band Emission Measurement

4.2.1 Limits of Conducted Out of Band Emission Measurement

Below 30dB of the highest emission level of operating band (in 100kHz Resolution Bandwidth).

4.2.2 Test Setup

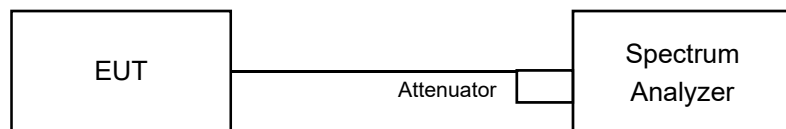

4.2.3 Test Instruments

Refer to section 4.1.2 to get information of above instrument.

4.2.4 Test Procedure

MEASUREMENT PROCEDURE REF

- Set the RBW = 100 kHz.
- Set the VBW \geq 300 kHz.
- Detector = peak.
- Sweep time = auto couple.
- Trace mode = max hold.
- Allow trace to fully stabilize.
- Use the peak marker function to determine the maximum power level in any 100 kHz band segment within the fundamental EBW.

MEASUREMENT PROCEDURE OOB

- Set RBW = 100 kHz.
- Set VBW \geq 300 kHz.
- Detector = peak.
- Sweep = auto couple.
- Trace Mode = max hold.
- Allow trace to fully stabilize.
- Use the peak marker function to determine the maximum amplitude level.

4.2.5 Deviation from Test Standard

No deviation.

4.2.6 EUT Operating Condition

The software provided by client to enable the EUT under transmission condition continuously at lowest, middle and highest channel frequencies individually.

4.2.7 Test Results

The spectrum plots are attached on the following pages. H1 line indicates the highest level, and H2 line indicates the 30dB offset below H1. It shows compliance with the requirement.

802.11b + 802.11ax (HE20)

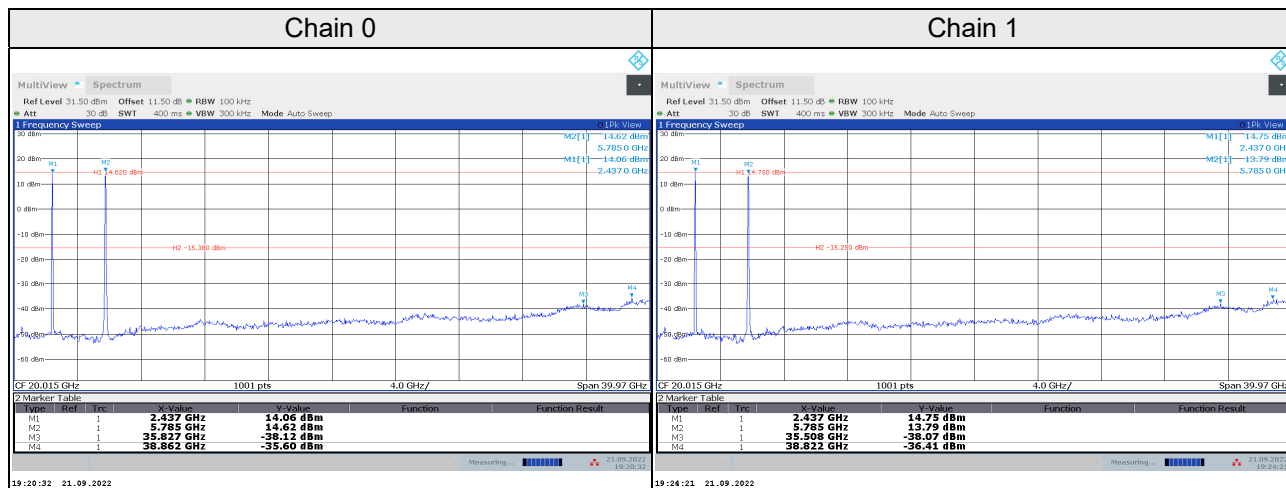

802.11b + 802.11ax (HE40)

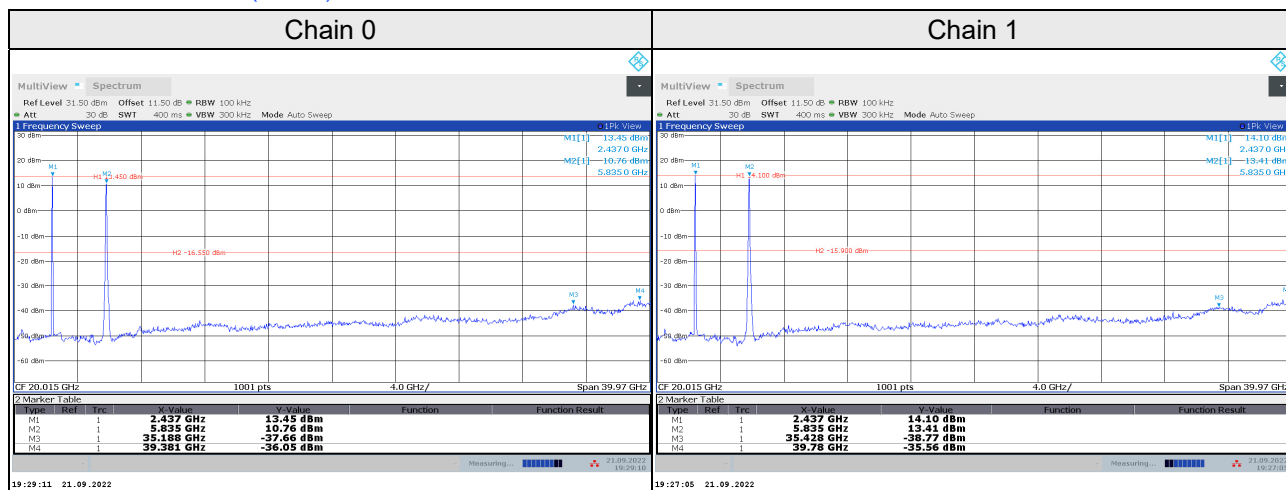

5 Pictures of Test Arrangements

Please refer to the attached file (Test Setup Photo).

Annex A – Band Edge Measurement

802.11b + 802.11ax (HE20)

802.11ax (HE20) CH 157 : 5785 MHz

Horizontal

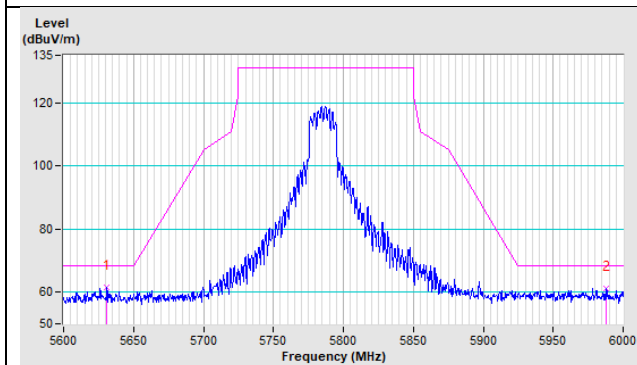

Vertical

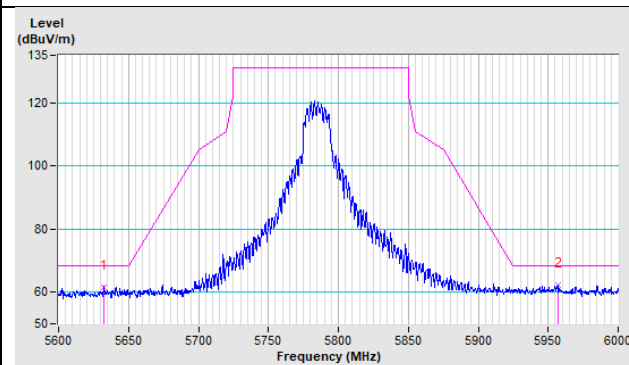

802.11b + 802.11ax (HE40)

802.11ax (HE40) CH 167 : 5835 MHz

Horizontal

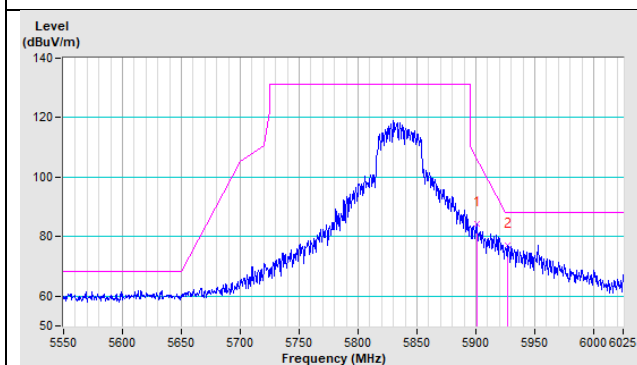

Vertical

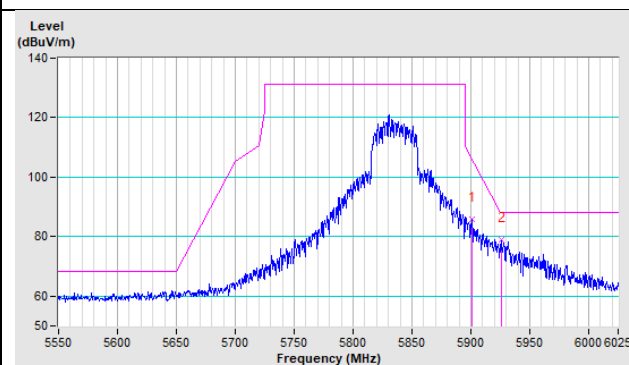

Appendix – Information of the Testing Laboratories

We, Bureau Veritas Consumer Products Services (H.K.) Ltd., Taoyuan Branch, were founded in 1988 to provide our best service in EMC, Radio, Telecom and Safety consultation. Our laboratories are FCC recognized accredited test firms and accredited and approved according to ISO/IEC 17025.

If you have any comments, please feel free to contact us at the following:

Lin Kou EMC/RF Lab

Tel: 886-2-26052180

Fax: 886-2-26051924

Hsin Chu EMC/RF/Telecom Lab

Tel: 886-3-6668565

Fax: 886-3-6668323

Hwa Ya EMC/RF/Safety

Tel: 886-3-3183232

Fax: 886-3-3270892

Email: service.adt@tw.bureauveritas.com

Web Site: www.bureauveritas-adt.com

The address and road map of all our labs can be found in our web site also.

--- END ---