

TEST REPORT

CERTIFICATE OF CONFORMITY

Standard: 47 CFR FCC Part 15, Subpart E (Section 15.407)

Report No.: RFBBQZ-WTW-P22090848-1

FCC ID: PY322100563

Product: Mesh WiFi 6E Router

Brand: NETGEAR

Model No.: MR90

Received Date: 2023/1/31

Test Date: 2023/2/24 ~ 2023/3/15

Issued Date: 2023/3/29

Applicant: NETGEAR, Inc.

Address: 350 East Plumeria Drive San Jose, CA 95134

Issued By: Bureau Veritas Consumer Products Services (H.K.) Ltd., Taoyuan Branch
Hsin Chu Laboratory

Lab Address: E-2, No.1, Li Hsin 1st Road, Hsinchu Science Park, Hsinchu City 300, Taiwan

Test Location: E-2, No.1, Li Hsin 1st Road, Hsinchu Science Park, Hsinchu City 300, Taiwan

FCC Registration / 723255 / TW2022

Designation Number:

Approved by:  , **Date:** 2023/3/29

May Chen / Manager

This test report consists of 167 pages in total. It may be duplicated completely for legal use with the approval of the applicant. It should not be reproduced except in full, without the written approval of our laboratory. The test results in the report only apply to the tested sample. The test results in this report are traceable to the national or international standards.

Prepared by : Vito Lung / Specialist



This report is governed by, and incorporates by reference, the Conditions of Testing as posted at the date of issuance of this report at <http://www.bureauveritas.com/home/about-us-our-business/cps/about-us/terms-conditions/> and is intended for your exclusive use. Any copying or replication of this report to or for any other person or entity, or use of our name or trademark, is permitted only with our prior written permission. This report sets forth our findings solely with respect to the test samples identified herein. The results set forth in this report are not indicative or representative of the quality or characteristics of the lot from which a test sample was taken or any similar or identical product unless specifically and expressly noted. Our report includes all of the tests requested by you and the results thereof based upon the information that you provided to us. Measurement uncertainty is only provided upon request for accredited tests. Statements of conformity are based on simple acceptance criteria without taking measurement uncertainty into account, unless otherwise requested in writing. You have 60 days from date of issuance of this report to notify us of any material error or omission caused by our negligence or if you require measurement uncertainty; provided, however, that such notice shall be in writing and shall specifically address the issue you wish to raise. A failure to raise such issue within the prescribed time shall constitute your unqualified acceptance of the completeness of this report, the tests conducted and the correctness of the report contents.

Table of Contents

Release Control Record	4
1 Certificate	5
2 Summary of Test Results	6
2.1 Measurement Uncertainty	6
2.2 Supplementary Information	6
3 General Information	7
3.1 General Description of EUT	7
3.2 Antenna Description of EUT	9
3.3 Channel List	10
3.4 Test Mode Applicability and Tested Channel Detail	12
3.5 Duty Cycle of Test Signal	14
3.6 Test Program Used and Operation Descriptions	16
3.7 Connection Diagram of EUT and Peripheral Devices	16
3.8 Configuration of Peripheral Devices and Cable Connections	17
4 Test Instruments	18
4.1 26 dB Bandwidth	18
4.2 RF Output Power	18
4.3 Power Spectral Density	18
4.4 6 dB Bandwidth	18
4.5 Occupied Bandwidth	18
4.6 Frequency Stability	19
4.7 AC Power Conducted Emissions	19
4.8 Unwanted Emissions below 1 GHz	20
4.9 Unwanted Emissions above 1 GHz	21
5 Limits of Test Items	22
5.1 26 dB Bandwidth	22
5.2 RF Output Power	22
5.3 Power Spectral Density	22
5.4 6 dB Bandwidth	22
5.5 Occupied Bandwidth	22
5.6 Frequency Stability	23
5.7 AC Power Conducted Emissions	23
5.8 Unwanted Emissions below 1 GHz	23
5.9 Unwanted Emissions above 1 GHz	24
6 Test Arrangements	25
6.1 26 dB Bandwidth	25
6.1.1 Test Setup	25
6.1.2 Test Procedure	25
6.2 RF Output Power	26
6.2.1 Test Setup	26
6.2.2 Test Procedure	26
6.3 Power Spectral Density	27
6.3.1 Test Setup	27
6.3.2 Test Procedure	27
6.4 6 dB Bandwidth	27
6.4.1 Test Setup	27
6.4.2 Test Procedure	27
6.5 Occupied Bandwidth	28
6.5.1 Test Setup	28
6.5.2 Test Procedure	28
6.6 Frequency Stability	28
6.6.1 Test Setup	28
6.6.2 Test Procedure	28
6.7 AC Power Conducted Emissions	29



6.7.1	Test Setup	29
6.7.2	Test Procedure	29
6.8	Unwanted Emissions below 1 GHz	30
6.8.1	Test Setup	30
6.8.2	Test Procedure	31
6.9	Unwanted Emissions above 1 GHz	32
6.9.1	Test Setup	32
6.9.2	Test Procedure	32
7	Test Results of Test Item	33
7.1	26 dB Bandwidth	33
7.2	RF Output Power	38
7.3	Power Spectral Density	48
7.4	6 dB Bandwidth	54
7.5	Occupied Bandwidth	56
7.6	Frequency Stability	62
7.7	AC Power Conducted Emissions	63
7.8	Unwanted Emissions below 1 GHz	65
7.9	Unwanted Emissions above 1 GHz	67
8	Pictures of Test Arrangements	166
9	Information of the Testing Laboratories	167



Release Control Record

Issue No.	Description	Date Issued
RFBBQZ-WTW-P22090848-1	Original release.	2023/3/29

1 Certificate

Product: Mesh WiFi 6E Router

Brand: NETGEAR

Test Model: MR90

Sample Status: Engineering sample

Applicant: NETGEAR, Inc.

Test Date: 2023/2/24 ~ 2023/3/15

Standard: 47 CFR FCC Part 15, Subpart E (Section 15.407)

Measurement ANSI C63.10-2013

procedure: KDB 789033 D02 General UNII Test Procedure New Rules v02r01
KDB 662911 D01 Multiple Transmitter Output v02r01

The above equipment has been tested by **Bureau Veritas Consumer Products Services (H.K.) Ltd., Taoyuan Branch**, and found compliance with the requirement of the above standards. The test record, data evaluation & Equipment Under Test (EUT) configurations represented herein are true and accurate accounts of the measurements of the sample's RF characteristics under the conditions specified in this report.

2 Summary of Test Results

47 CFR FCC Part 15, Subpart E (Section 15.407)			
Clause	Test Item	Result	Remark
15.407(a)(2)	26 dB Bandwidth	Pass	For U-NII-2A U-NII-2C Band output power limitation is determined based on 26dBc bandwidth.
15.407(a)(1) 15.407(a)(2) 15.407(a)(3)	RF Output Power	Pass	Meet the requirement of limit.
15.407(a)(1) 15.407(a)(2) 15.407(a)(3)	Power Spectral Density	Pass	Meet the requirement of limit.
15.407(e)	6 dB Bandwidth	Pass	Meet the requirement of limit. (U-NII-3 Band only)
---	Occupied Bandwidth	-	Reference only.
15.407(g)	Frequency Stability	Pass	Meet the requirement of limit.
15.407(b)(9)	AC Power Conducted Emissions	Pass	Minimum passing margin is -6.59 dB at 0.35062 MHz
15.407(b)(9)	Unwanted Emissions below 1 GHz	Pass	Minimum passing margin is -5.9 dB at 63.73 MHz
15.407(b) (1/10) 15.407(b) (2/10) 15.407(b) (3/10) 15.407(b) (4(i)/10)	Unwanted Emissions above 1 GHz	Pass	Minimum passing margin is -0.1 dB at 5150.00, 5460.00, 5644.38 MHz
15.203	Antenna Requirement	Pass	Antenna connector is ipex(MHF) not a standard connector.

Note: Determining compliance based on the results of the compliance measurement, not taking into account measurement instrumentation uncertainty.

2.1 Measurement Uncertainty

Where relevant, the following measurement uncertainty levels have been estimated for tests performed on the EUT as specified in CISPR 16-4-2:

Measurement	Specification	Expanded Uncertainty (k=2) (±)
AC Power Conducted Emissions	150 kHz ~ 30 MHz	1.9 dB
Unwanted Emissions below 1 GHz	9 kHz ~ 30 MHz	3.1 dB
	30 MHz ~ 1 GHz	5.5 dB
Unwanted Emissions above 1 GHz	1 GHz ~ 18 GHz	5.1 dB
	18 GHz ~ 40 GHz	5.3 dB

The other instruments specified are routine verified to remain within the calibrated levels, no measurement uncertainty is required to be calculated.

2.2 Supplementary Information

There is not any deviation from the test standards for the test method, and no modifications required for compliance.

3 General Information

3.1 General Description of EUT

Product	Mesh WiFi 6E Router
Brand	NETGEAR
Test Model	MR90
Status of EUT	Engineering sample
Power Supply Rating	Refer to Note
Modulation Type	64QAM, 16QAM, QPSK, BPSK for OFDM 256QAM for OFDM in 11ac mode 1024QAM for OFDMA in 11ax HE mode
Modulation Technology	OFDM, OFDMA
Transfer Rate	802.11a: up to 54 Mbps 802.11n: up to 300 Mbps 802.11ac: up to 1733.3 Mbps 802.11ax: up to 2401.9 Mbps
Operating Frequency	5.18 GHz ~ 5.25 GHz 5.26 GHz ~ 5.32 GHz 5.5 GHz ~ 5.72 GHz 5.745 GHz ~ 5.825 GHz
Number of Channel	802.11a, 802.11n (HT20), 802.11ac (VHT20), 802.11ax (HE20): 25 802.11n (HT40), 802.11ac (VHT40), 802.11ax (HE40): 12 802.11ac (VHT80), 802.11ax (HE80): 6 802.11ac (VHT160), 802.11ax (HE160): 2
Output Power	CDD Mode: 5.18 GHz ~ 5.25 GHz : 729.554 mW (28.63 dBm) 5.26 GHz ~ 5.32 GHz : 249.055 mW (23.96 dBm) 5.5 GHz ~ 5.72 GHz : 246.251 mW (23.91 dBm) 5.745 GHz ~ 5.825 GHz : 922.294 mW (29.65 dBm) Beamforming Mode: 5.18 GHz ~ 5.25 GHz : 672.347 mW (28.28 dBm) 5.26 GHz ~ 5.32 GHz : 550.83 mW (27.41 dBm) 5.5 GHz ~ 5.72 GHz : 246.251 mW (23.91 dBm) 5.745 GHz ~ 5.825 GHz : 922.294 mW (29.65 dBm)
EUT Category	Indoor Access Point

Note:

1. Simultaneously transmission condition.

Condition	Technology		
1	WLAN 2.4GHz	WLAN 5GHz	WLAN 6GHz

Note: The emission of the simultaneous operation has been evaluated and no non-compliance was found.

2. The EUT has below radios as following table:

Radios 1	Radios 2
WLAN 2.4GHz	WLAN 5GHz + WLAN 6GHz

3. The EUT uses following accessories.

AC Adapter 1		
Brand	Model	Specification
NETGEAR	2AED030FC	Part Number: 332-11595-01 AC Input: 100-120V~60Hz Max 1.0A DC Output: 12V, 2.5A DC Output Cable: unshielded, 1.8m without core
AC Adapter 2		
Brand	Model	Specification
NETGEAR	ADS-40FPC-12 12030E	Part Number: 332-11585-02 AC Input: 100-120V~50/60Hz 1.0A DC Output: 12V, 2.5A DC Output Cable: unshielded, 1.8m without core
Ethernet Cable		
Brand	Model	Specification
NETGEAR	312-10138-01	Signal Line : 2m, Unshielded

4. The above EUT information is declared by manufacturer and for more detailed features description, please refer to the manufacturer's specifications or user's manual.

3.2 Antenna Description of EUT

1. The antenna information is listed as below.

Antenna NO.	RF Chain NO.	Antenna Net Gain(dBi)	Frequency range (GHz)	Antenna Type	Connector Type
2G	2G-0	2.15	2.4~2.4835	PIFA	ipex(MHF)
DB1	2G-1	2.21	2.4~2.4835	PIFA	ipex(MHF)
DB2	2G-2	2.29	2.4~2.4835	PIFA	ipex(MHF)
5G1	5G-0	2.38	5.15~5.25	PIFA	ipex(MHF)
		2.38	5.25~5.35		
		2.65	5.47~5.725		
		2.69	5.725~5.85		
		2.69	5.85~5.895		
5G2	5G-1	2.49	5.15~5.25	PIFA	ipex(MHF)
		2.49	5.25~5.35		
		2.81	5.47~5.725		
		2.54	5.725~5.85		
		2.54	5.85~5.895		
DB1	6G-0	2.85	5.925~6.425	PIFA	ipex(MHF)
		2.89	6.425~6.525		
		2.89	6.525~6.875		
		2.93	6.875~7.125		
DB2	6G-1	2.98	5.925~6.425	PIFA	ipex(MHF)
		2.87	6.425~6.525		
		2.87	6.525~6.875		
		2.99	6.875~7.125		

* Detail antenna specification please refer to antenna datasheet and/or antenna measurement report.

2. The EUT incorporates a MIMO function:

5 GHz Band		
Modulation Mode	TX & RX Configuration	
802.11a	2TX	2RX
802.11n (HT20)	2TX	2RX
802.11n (HT40)	2TX	2RX
802.11ac (VHT20)	2TX	2RX
802.11ac (VHT40)	2TX	2RX
802.11ac (VHT80)	2TX	2RX
802.11ac (VHT160)	2TX	2RX
802.11ax (HE20)	2TX	2RX
802.11ax (HE40)	2TX	2RX
802.11ax (HE80)	2TX	2RX
802.11ax (HE160)	2TX	2RX

Note:

- All of modulation mode support beamforming function except 802.11a modulation mode.
- The EUT support Beamforming and CDD mode, therefore both mode were investigated and the worst case scenario was identified. The worst case data were presented in test report.
- The modulation and bandwidth are similar for 802.11n mode for 20 MHz (40 MHz), 802.11ac mode for 20 MHz (40 MHz, 80 MHz) and 802.11ax mode for 20 MHz (40 MHz, 80 MHz, 160 MHz), therefore the manufacturer will control the power for 802.11n/ac mode is the same as the 802.11ax or more lower than it and investigated worst case to representative mode in test report.

3.3 Channel List

FOR 5180 ~ 5320 MHz

8 channels are provided for 802.11a, 802.11n (HT20), 802.11ac (VHT20), 802.11ax (HE20):

Channel	Frequency	Channel	Frequency
36	5180 MHz	52	5260 MHz
40	5200 MHz	56	5280 MHz
44	5220 MHz	60	5300 MHz
48	5240 MHz	64	5320 MHz

4 channels are provided for 802.11n (HT40), 802.11ac (VHT40), 802.11ax (HE40):

Channel	Frequency	Channel	Frequency
38	5190 MHz	54	5270 MHz
46	5230 MHz	62	5310 MHz

2 channels are provided for 802.11ac (VHT80), 802.11ax (HE80):

Channel	Frequency	Channel	Frequency
42	5210 MHz	58	5290 MHz

1 straddle channel is provided for 802.11ac (VHT160), 802.11ax (HE160):

Channel	Frequency
50	5250 MHz

FOR 5500 ~ 5720 MHz

12 channels are provided for 802.11a, 802.11n (HT20), 802.11ac (VHT20), 802.11ax (HE20):

Channel	Frequency	Channel	Frequency
100	5500 MHz	124	5620 MHz
104	5520 MHz	128	5640 MHz
108	5540 MHz	132	5660 MHz
112	5560 MHz	136	5680 MHz
116	5580 MHz	140	5700 MHz
120	5600 MHz	144	5720 MHz

6 channels are provided for 802.11n (HT40), 802.11ac (VHT40), 802.11ax (HE40):

Channel	Frequency	Channel	Frequency
102	5510 MHz	126	5630 MHz
110	5550 MHz	134	5670 MHz
118	5590 MHz	142	5710 MHz

3 channels are provided for 802.11ac (VHT80), 802.11ax (HE80):

Channel	Frequency	Channel	Frequency
106	5530 MHz	138	5690 MHz
122	5610 MHz		

1 channels are provided for 802.11ac (VHT160), 802.11ax (HE160):

Channel	Frequency
114	5570 MHz

FOR 5745 ~ 5825 MHz:

5 channels are provided for 802.11a, 802.11n (HT20), 802.11ac (VHT20), 802.11ax (HE20):

Channel	Frequency	Channel	Frequency
149	5745 MHz	161	5805 MHz
153	5765 MHz	165	5825 MHz
157	5785 MHz		

2 channels are provided for 802.11n (HT40), 802.11ac (VHT40), 802.11ax (HE40):

Channel	Frequency	Channel	Frequency
151	5755 MHz	159	5795 MHz

1 channel is provided for 802.11ac (VHT80), 802.11ax (HE80):

Channel	Frequency
155	5775 MHz

3.4 Test Mode Applicability and Tested Channel Detail

Pre-Scan:	1. The AC Adapter has the following models: Adapter 1: 2AED030FC / Adapter 2: ADS-40FPC-12 12030E. Pre-scan these models of AC Adapters and find the worst case as a representative test condition. 2. Pre-Scan has been conducted to determine the worst-case mode from all possible combinations between available modulations, data rates and antenna ports (if EUT with antenna diversity architecture).
Worst Case:	1. AC Adapter Worst Condition: Adapter 1: 2AED030FC 2. The EUT is usually used lying flat and was therefore chosen for Unwanted Emission testing.

Following channel(s) was (were) selected for the final test as listed below:

Test Item	Mode	Signal Mode	Tested Channel	Modulation	Data Rate Parameter
26 dB Bandwidth	802.11a	CDD	52, 60, 64, 100, 116, 140, 144	BPSK	6Mb/s
	802.11ax (HE20)	CDD	52, 60, 64, 100, 116, 140, 144	BPSK	MCS0
	802.11ax (HE40)	CDD	54, 62, 102, 110, 134, 142	BPSK	MCS0
	802.11ax (HE80)	CDD	58, 106, 122, 138	BPSK	MCS0
	802.11ax (HE160)	CDD	50, 114	BPSK	MCS0
RF Output Power	802.11a	CDD	36, 40, 48, 52, 60, 64, 100, 116, 140, 144, 149, 157, 165	BPSK	6Mb/s
	802.11ax (HE20)	CDD & Beamforming	36, 40, 48, 52, 60, 64, 100, 116, 140, 144, 149, 157, 165	BPSK	MCS0
	802.11ax (HE40)	CDD & Beamforming	38, 46, 54, 62, 102, 110, 134, 142, 151, 159	BPSK	MCS0
	802.11ax (HE80)	CDD & Beamforming	42, 58, 106, 122, 138, 155	BPSK	MCS0
	802.11ax (HE160)	CDD & Beamforming	50, 114	BPSK	MCS0
Power Spectral Density	802.11a	CDD	36, 40, 48, 52, 60, 64, 100, 116, 140, 144, 149, 157, 165	BPSK	6Mb/s
	802.11ax (HE20)	CDD	36, 40, 48, 52, 60, 64, 100, 116, 140, 144, 149, 157, 165	BPSK	MCS0
	802.11ax (HE40)	CDD	38, 46, 54, 62, 102, 110, 134, 142, 151, 159	BPSK	MCS0
	802.11ax (HE80)	CDD	42, 58, 106, 122, 138, 155	BPSK	MCS0
	802.11ax (HE160)	CDD	50, 114	BPSK	MCS0

Test Item	Mode	Signal Mode	Tested Channel	Modulation	Data Rate Parameter
6 dB Bandwidth	802.11a	CDD	144, 149, 157, 165	BPSK	6Mb/s
	802.11ax (HE20)	CDD	144, 149, 157, 165	BPSK	MCS0
	802.11ax (HE40)	CDD	142, 151, 159	BPSK	MCS0
	802.11ax (HE80)	CDD	138, 155	BPSK	MCS0
Occupied Bandwidth	802.11a	CDD	36, 40, 48, 52, 60, 64, 100, 116, 140, 144, 149, 157, 165	BPSK	6Mb/s
	802.11ax (HE20)	CDD	36, 40, 48, 52, 60, 64, 100, 116, 140, 144, 149, 157, 165	BPSK	MCS0
	802.11ax (HE40)	CDD	38, 46, 54, 62, 102, 110, 134, 142, 151, 159	BPSK	MCS0
	802.11ax (HE80)	CDD	42, 58, 106, 122, 138, 155	BPSK	MCS0
	802.11ax (HE160)	CDD	50, 114	BPSK	MCS0
Frequency Stability	802.11a	CDD	36	un-modulation	-
AC Power Conducted Emissions	802.11ax (HE20)	CDD	157	BPSK	MCS0
Unwanted Emissions below 1 GHz	802.11ax (HE20)	CDD	157	BPSK	MCS0
Unwanted Emissions above 1 GHz	802.11a	CDD	36, 40, 48, 52, 60, 64, 100, 116, 140, 144, 149, 157, 165	BPSK	6Mb/s
	802.11ax (HE20)	CDD	36, 40, 48, 52, 60, 64, 100, 116, 140, 144, 149, 157, 165	BPSK	MCS0
	802.11ax (HE40)	CDD	38, 46, 54, 62, 102, 110, 134, 142, 151, 159	BPSK	MCS0
	802.11ax (HE80)	CDD	42, 58, 106, 122, 138, 155	BPSK	MCS0
	802.11ax (HE160)	CDD	50, 114	BPSK	MCS0

3.5 Duty Cycle of Test Signal

802.11a: Duty cycle = 2.152 ms / 2.182 ms x 100% = 98.6%

802.11ax (HE20): Duty cycle = 1.529 ms / 1.558 ms x 100% = 98.1%

802.11ax (HE40): Duty cycle = 1.514 ms / 1.544 ms x 100% = 98.1%

802.11ax (HE80): Duty cycle = 1.583 ms / 1.612 ms x 100% = 98.2%

802.11ax (HE160): Duty cycle = 2.143 ms / 2.171 ms x 100% = 98.7%

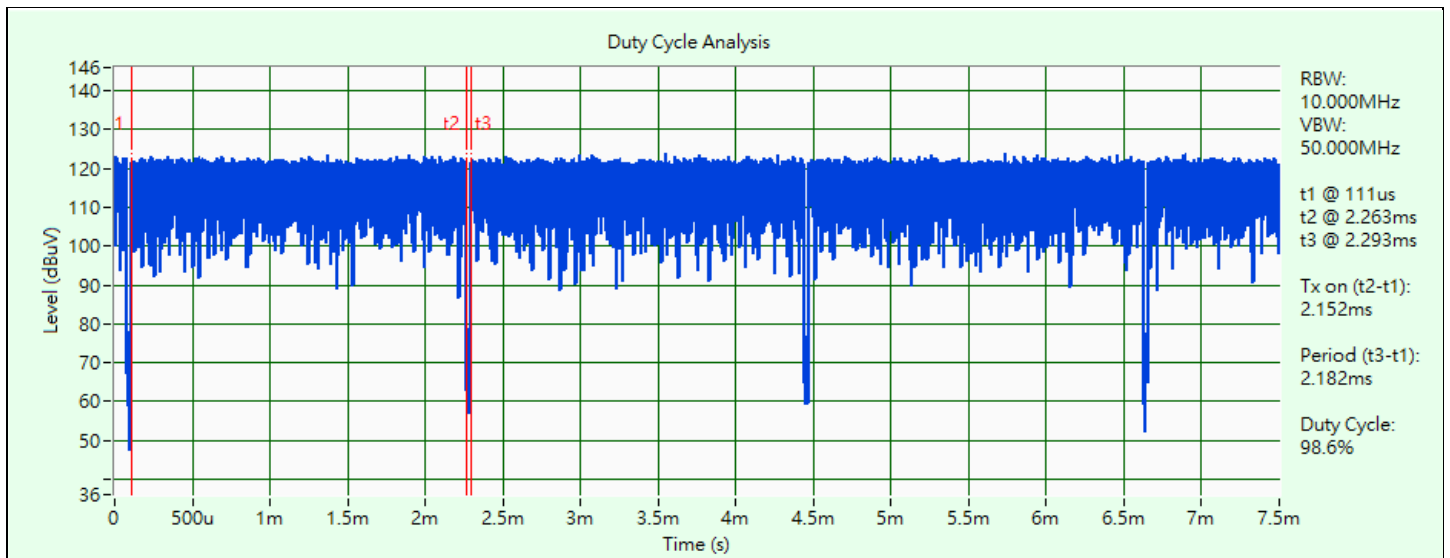

802.11a

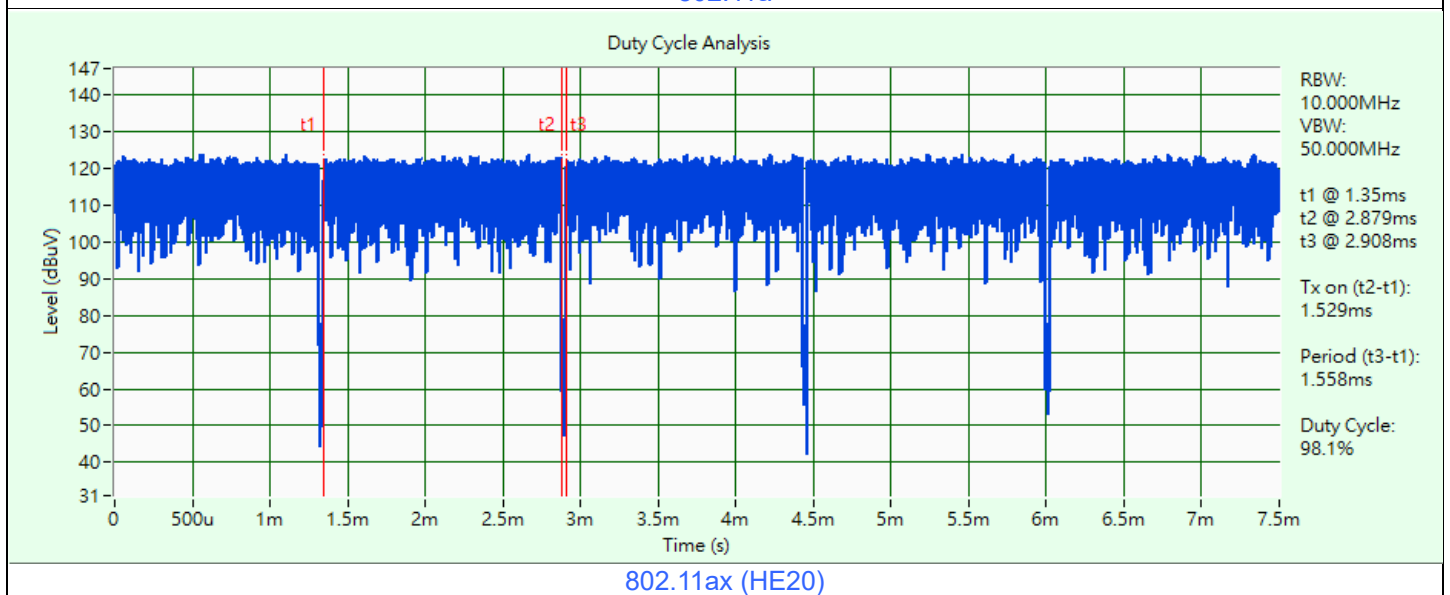

802.11ax (HE20)

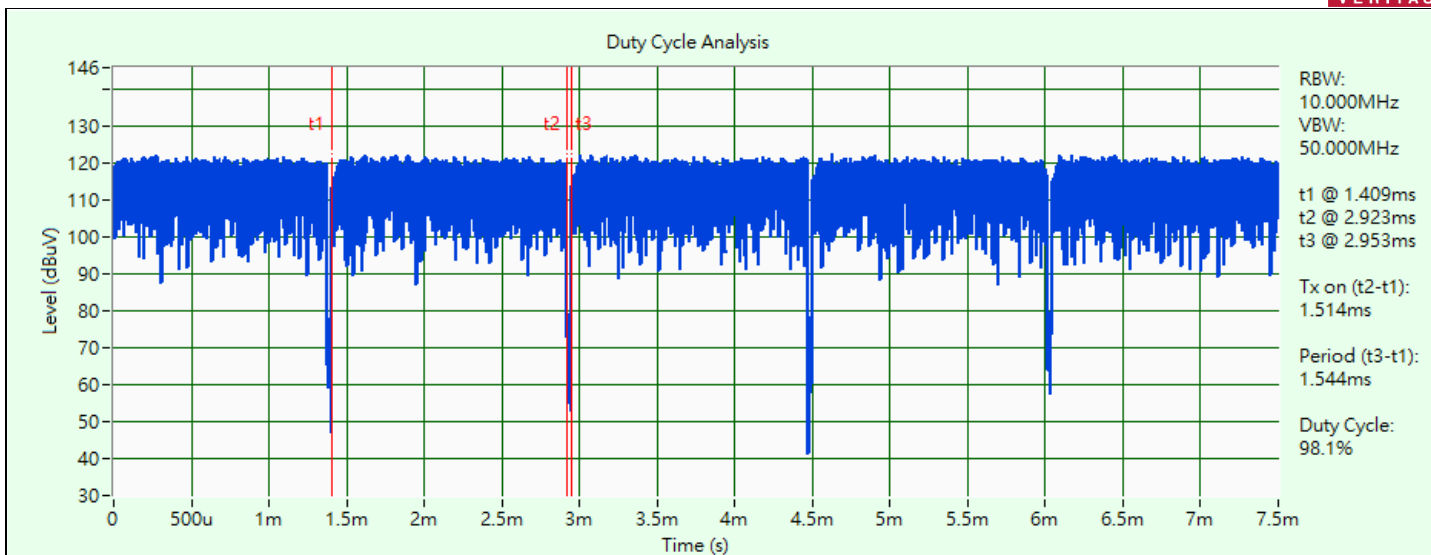

802.11ax (HE40)

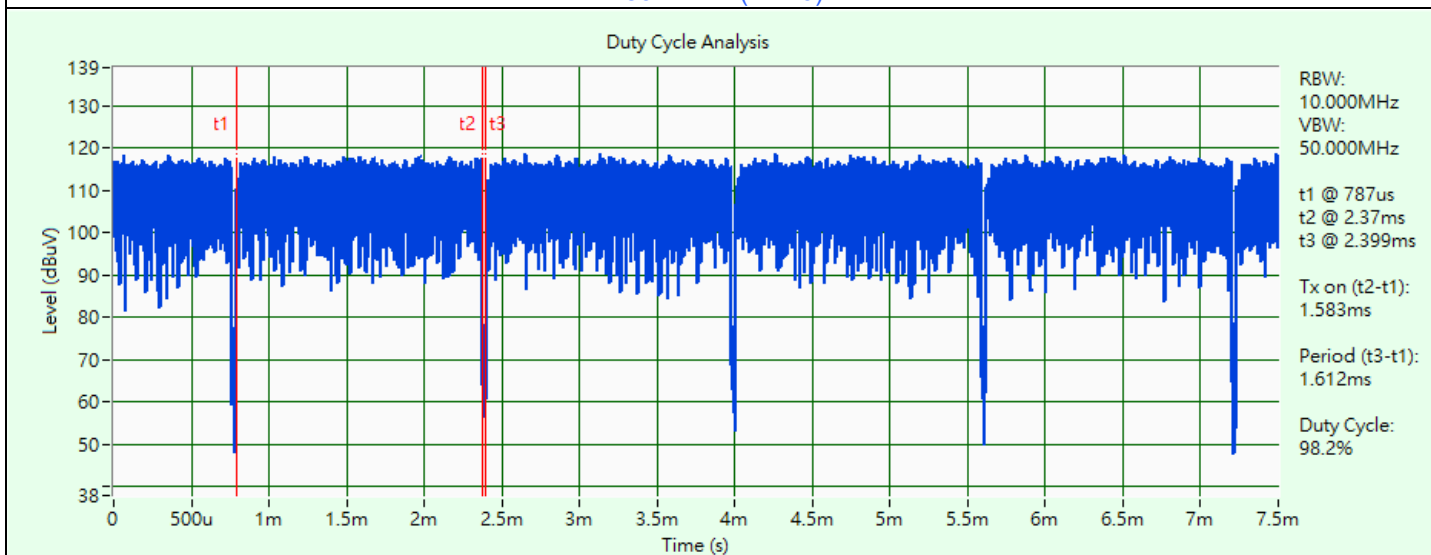

802.11ax (HE80)

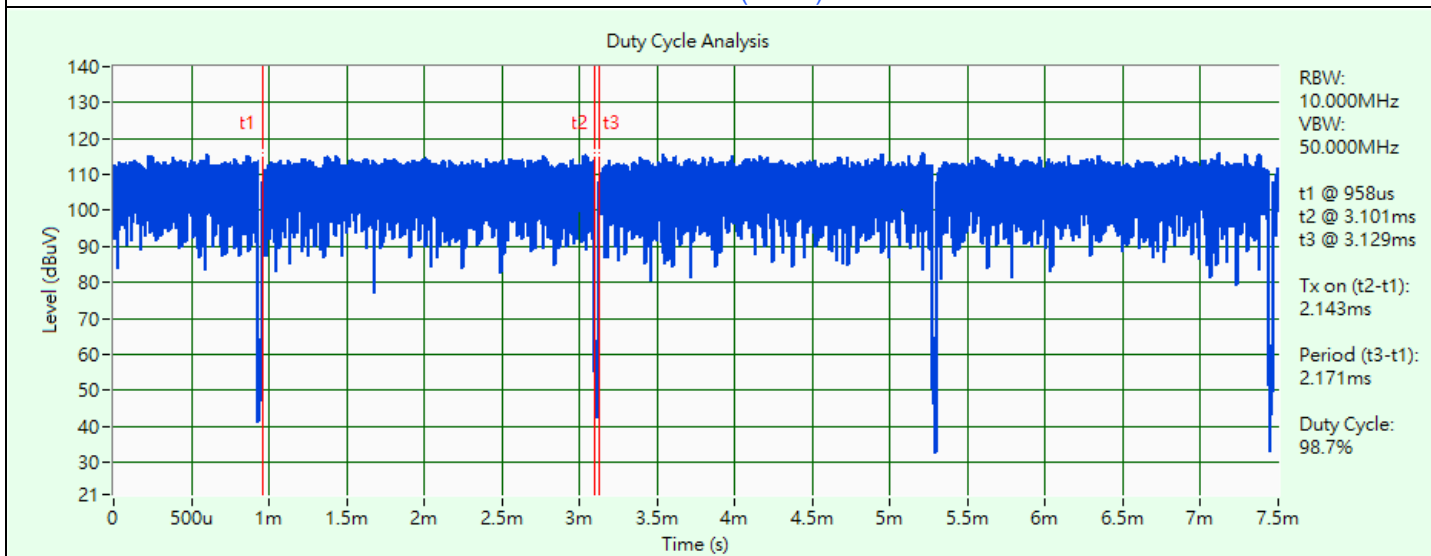

802.11ax (HE160)

3.6 Test Program Used and Operation Descriptions

Controlling software (accessMTool_REL_3_3_0_1) has been activated to set the EUT under transmission condition continuously at specific channel frequency.

3.7 Connection Diagram of EUT and Peripheral Devices

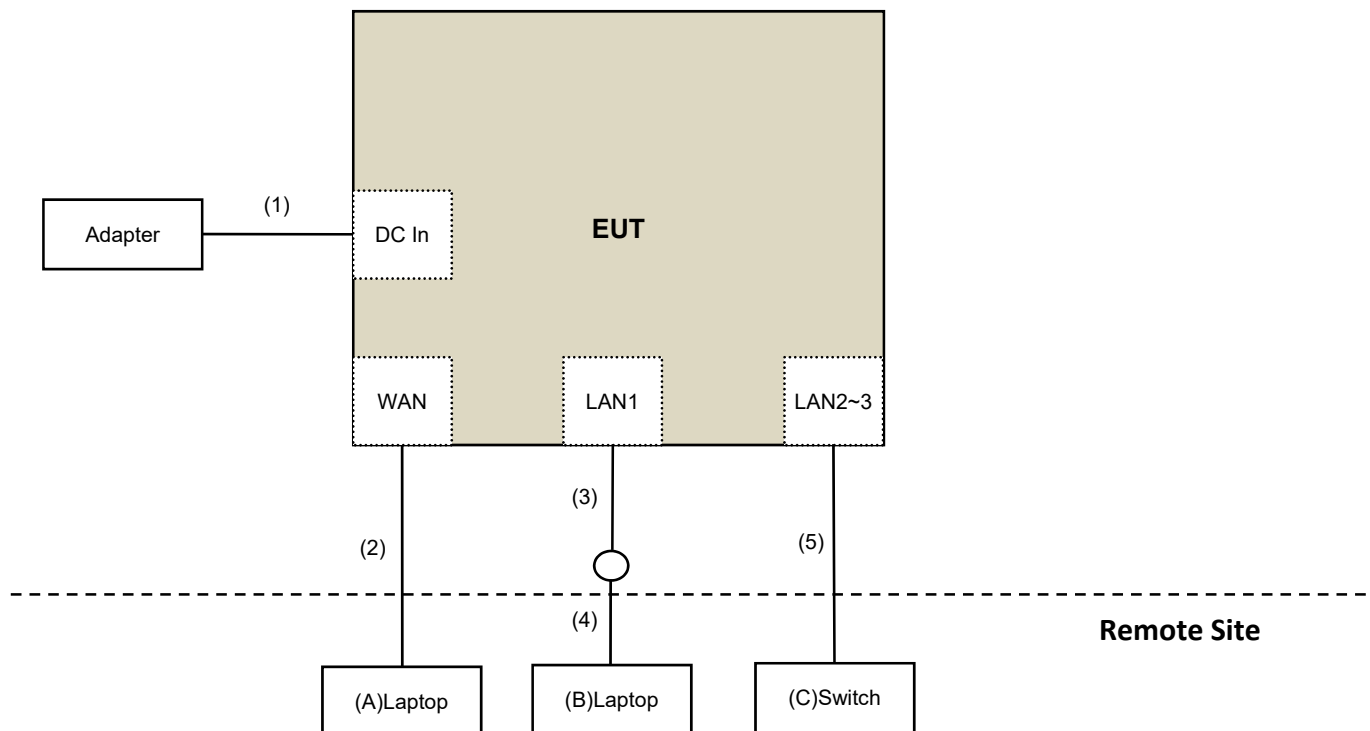

3.8 Configuration of Peripheral Devices and Cable Connections

ID	Product	Brand	Model No.	Serial No.	FCC ID	Remarks
A	Laptop	Lenovo	20U5S01X00 L14	PF-28LKK7	N/A	Provided by Lab
B	Laptop	Lenovo	20U5S01X00 L14	PF-1ANPYA	N/A	Provided by Lab
C	Switch	D-Link	DGS-1005D	DR8WC92000523	N/A	Provided by Lab

ID	Cable Descriptions	Qty.	Length (m)	Shielding (Yes/No)	Cores (Qty.)	Remarks
1	DC Cable	1	1.8	No	0	Supplied by applicant
2	RJ45	1	10	No	0	Provided by Lab
3	RJ45	1	2	No	0	Supplied by applicant
4	RJ45	1	10	No	0	Provided by Lab
5	RJ45	2	10	No	0	Provided by Lab

4 Test Instruments

The calibration interval of the all test instruments are 12 months and the calibrations are traceable to NML/ROC and NIST/USA.

4.1 26 dB Bandwidth

Description Manufacturer	Model No.	Serial No.	Calibrated Date	Calibrated Until
Attenuator WOKEN	MDCS18N-10	MDCS18N-10-01	2022/4/5	2023/4/4
Software	ADT_RF Test Software V6.6.5.4	N/A	N/A	N/A
Spectrum Analyzer Keysight	N9020B	MY60112409	2023/2/18	2024/2/17

Notes:

1. The test was performed in Oven room 2.
2. Tested Date: 2023/3/10

4.2 RF Output Power

Description Manufacturer	Model No.	Serial No.	Calibrated Date	Calibrated Until
Attenuator WOKEN	MDCS18N-10	MDCS18N-10-01	2022/4/5	2023/4/4
Power Meter Anritsu	ML2495A	1529002	2022/6/22	2023/6/21
Pulse Power Sensor Anritsu	MA2411B	1726434	2022/6/22	2023/6/21
Software	ADT_RF Test Software V6.6.5.4	N/A	N/A	N/A
Spectrum Analyzer Keysight	N9020B	MY60112409	2023/2/18	2024/2/17

Notes:

1. The test was performed in Oven room 2.
2. Tested Date: 2023/3/10

4.3 Power Spectral Density

Refer to section 4.1 to get information of the instruments.

4.4 6 dB Bandwidth

Refer to section 4.1 to get information of the instruments.

4.5 Occupied Bandwidth

Refer to section 4.1 to get information of the instruments.

4.6 Frequency Stability

Description Manufacturer	Model No.	Serial No.	Calibrated Date	Calibrated Until
AC Power Source GOOD WILL	6905S	1991551	N/A	N/A
Attenuator WOKEN	MDCS18N-10	MDCS18N-10-01	2022/4/5	2023/4/4
Software	ADT_RF Test Software V6.6.5.4	N/A	N/A	N/A
Spectrum Analyzer Keysight	N9020B	MY60112409	2023/2/18	2024/2/17
Temperature & Humidity Chamber Giant Force	GTH-150-40-SP-AR	MAA0812-008	2022/12/26	2023/12/25
True RMS Clamp Meter Fluke	325	31130711WS	2022/6/9	2023/6/8

Notes:

1. The test was performed in Oven room 2.
2. Tested Date: 2023/3/10

4.7 AC Power Conducted Emissions

Description Manufacturer	Model No.	Serial No.	Calibrated Date	Calibrated Until
50 ohm terminal resistance	N/A	EMC-01	2022/9/27	2023/9/26
Fixed attenuator STI	STI02-2200-10	005	2022/8/24	2023/8/23
LISN R&S	ESH3-Z5	848773/004	2022/10/18	2023/10/17
RF Coaxial Cable JYEBO	5D-FB	COCCAB-001	2022/8/24	2023/8/23
Software BVADT	BVADT_Cond_V7.3.7.4	N/A	N/A	N/A
TEST RECEIVER R&S	ESCS 30	847124/029	2022/10/14	2023/10/13

Notes:

1. The test was performed in Conduction 1
2. Tested Date: 2023/3/13

4.8 Unwanted Emissions below 1 GHz

Description Manufacturer	Model No.	Serial No.	Calibrated Date	Calibrated Until
Boresight Antenna Tower & Turn Table Max-Full	MF-7802BS	MF780208530	N/A	N/A
Fixed attenuator Mini-Circuits	UNAT-5+	PAD-ATT5-03	2022/12/28	2023/12/27
LOOP ANTENNA Electro-Metrics	EM-6879	264	2022/3/18	2023/3/17
Pre_Amplifier Agilent	8447D	2944A10636	2022/3/19	2023/3/18
Pre_Amplifier EMCI	EMC330N	980701	2023/2/18	2024/2/17
RF Coaxial Cable COMMATE/PEWC	8D	966-4-1	2023/2/18	2024/2/17
		966-4-2	2023/2/18	2024/2/17
		966-4-3	2023/2/18	2024/2/17
RF Coaxial Cable JYEBO	5D-FB	LOOPCAB-001	2022/12/19	2023/12/18
		LOOPCAB-002	2022/12/19	2023/12/18
Software	ADT_Radiated_V8.7.08	N/A	N/A	N/A
Spectrum Analyzer KEYSIGHT	N9030B	MY57142938	2022/4/26	2023/4/25
Trilog Broadband Antenna Schwarzbeck	VULB 9168	9168-406	2022/10/21	2023/10/20

Notes:

1. The test was performed in 966 Chamber No. 4.
2. Tested Date: 2023/3/15

4.9 Unwanted Emissions above 1 GHz

Description Manufacturer	Model No.	Serial No.	Calibrated Date	Calibrated Until
Boresight Antenna Tower & Turn Table Max-Full	MF-7802BS	MF780208530	N/A	N/A
Horn Antenna Schwarzbeck	BBHA 9120D	9120D-783	2022/11/13	2023/11/12
	BBHA 9170	9170-739	2022/11/13	2023/11/12
Pre_Amplifier EMCI	EMC12630SE	980688	2022/10/4	2023/10/3
	EMC184045SE	980387	2022/12/28	2023/12/27
RF Cable-Frequency Range : 1- 26.5GHz EMCI	EMC104-SM-SM-1200	160922	2022/12/15	2023/12/14
RF Cable-Frequency range: 1- 40GHz EMCI	EMC102-KM-KM-1200	160924	2022/12/28	2023/12/27
RF Coaxial Cable EMCI	EMC-KM-KM-4000	200214	2023/2/20	2024/2/19
	EMC104-SM-SM-2000	180502	2022/4/25	2023/4/24
	EMC104-SM-SM-6000	210704	2022/11/4	2023/11/3
Software	ADT_Radiated_V8.7.08	N/A	N/A	N/A
Spectrum Analyzer KEYSIGHT	N9030B	MY57142938	2022/4/26	2023/4/25

Notes:

1. The test was performed in 966 Chamber No. 4.
2. Tested Date: 2023/2/24 ~ 2023/3/10

5 Limits of Test Items

5.1 26 dB Bandwidth

The results are for reference only.

5.2 RF Output Power

Operation Band	EUT Category	Limit
U-NII-1	Outdoor Access Point	1 Watt (30 dBm) (Max. e.i.r.p \leq 125mW(21 dBm) at any elevation angle above 30 degrees as measured from the horizon)
	Fixed point-to-point Access Point	1 Watt (30 dBm)
	Indoor Access Point	1 Watt (30 dBm)
	Mobile and Portable client device	250mW (24 dBm)

Operation Band	Limit
U-NII-2A	250 mW (24 dBm) or 11 dBm+10 log B*
U-NII-2C	250 mW (24 dBm) or 11 dBm+10 log B*
U-NII-3	1 Watt (30 dBm)

*B is the 26 dB emission bandwidth in megahertz

Per KDB 662911 D01 Multiple Transmitter Output Method of conducted output power measurement on IEEE 802.11 devices,

Array Gain = 0 dB (i.e., no array gain) for $N_{ANT} \leq 4$;

Array Gain = 0 dB (i.e., no array gain) for channel widths ≥ 40 MHz for any N_{ANT} ;

Array Gain = 5 log(N_{ANT}/N_{SS}) dB or 3 dB, whichever is less, for 20-MHz channel widths with $N_{ANT} \geq 5$.

For power measurements on all other devices: Array Gain = 10 log(N_{ANT}/N_{SS}) dB.

5.3 Power Spectral Density

Operation Band	EUT Category	Limit
U-NII-1	Outdoor Access Point	17 dBm/MHz
	Fixed point-to-point Access Point	
	Indoor Access Point	
	Mobile and Portable client device	11 dBm/MHz

Operation Band	Limit
U-NII-2A	11 dBm/MHz
U-NII-2C	11 dBm/MHz
U-NII-3	30 dBm/500 kHz

5.4 6 dB Bandwidth

Within the 5.725-5.850 GHz band, the minimum 6 dB bandwidth of U-NII devices shall be at least 500 kHz.

5.5 Occupied Bandwidth

The results are for reference only.

5.6 Frequency Stability

The frequency of the carrier signal shall be maintained within band of operation.

5.7 AC Power Conducted Emissions

Frequency (MHz)	Conducted Limit (dBuV)	
	Quasi-peak	Average
0.15 - 0.5	66 - 56	56 - 46
0.50 - 5.0	56	46
5.0 - 30.0	60	50

Notes:

1. The lower limit shall apply at the transition frequencies.
2. The limit decreases in line with the logarithm of the frequency in the range of 0.15 to 0.50 MHz.

5.8 Unwanted Emissions below 1 GHz

Radiated emissions which fall in the restricted bands must comply with the radiated emission limits specified as below table.

Frequencies (MHz)	Field Strength (microvolts/meter)	Measurement Distance (meters)
0.009 ~ 0.490	2400/F(kHz)	300
0.490 ~ 1.705	24000/F(kHz)	30
1.705 ~ 30.0	30	30
30 ~ 88	100	3
88 ~ 216	150	3
216 ~ 960	200	3
Above 960	500	3

Notes:

1. The lower limit shall apply at the transition frequencies.
2. Emission level (dBuV/m) = 20 log Emission level (uV/m).

5.9 Unwanted Emissions above 1 GHz

Radiated emissions which fall in the restricted bands must comply with the radiated emission limits specified as below table.

Frequencies (MHz)	Field Strength (microvolts/meter)	Measurement Distance (meters)
Above 960	500	3

Notes:

1. The lower limit shall apply at the transition frequencies.
2. Emission level (dBuV/m) = 20 log Emission level (uV/m).
3. For frequencies above 1000 MHz, the field strength limits are based on average detector, however, the peak field strength of any emission shall not exceed the maximum permitted average limits, specified above by more than 20 dB under any condition of modulation.

Limits of unwanted emission out of the restricted bands

Applicable To	Limit	
789033 D02 General UNII Test Procedure New Rules v02r01	Field Strength at 3 m	
	PK: 74 (dBμV/m)	AV: 54 (dBμV/m)

For transmitters operating in the 5.15-5.25 GHz band:

Applicable To	EIRP Limit	Equivalent Field Strength at 3 m
15.407(b)(1)	PK: -27 (dBm/MHz)	PK: 68.2 (dBμV/m)

For transmitters operating in the 5.25-5.35 GHz band:

Applicable To	EIRP Limit	Equivalent Field Strength at 3 m
15.407(b)(2)	PK: -27 (dBm/MHz)	PK: 68.2 (dBμV/m)

For transmitters operating in the 5.47-5.725 GHz band:

Applicable To	EIRP Limit	Equivalent Field Strength at 3 m
15.407(b)(3)	PK: -27 (dBm/MHz)	PK: 68.2 (dBμV/m)

For transmitters operating in the 5.725-5.850 GHz band:

Applicable To	EIRP Limit	Equivalent Field Strength at 3 m
15.407(b)(4)(i)	PK: -27 (dBm/MHz) ^{*1}	PK: 68.2 (dBμV/m) ^{*1}
	PK: 10 (dBm/MHz) ^{*2}	PK: 105.2 (dBμV/m) ^{*2}
	PK: 15.6 (dBm/MHz) ^{*3}	PK: 110.8 (dBμV/m) ^{*3}
	PK: 27 (dBm/MHz) ^{*4}	PK: 122.2 (dBμV/m) ^{*4}

^{*1} beyond 75 MHz or more above of the band edge.

^{*2} below the band edge increasing linearly to 10 dBm/MHz at 25 MHz above.

^{*3} below the band edge increasing linearly to a level of 15.6 dBm/MHz at 5 MHz above.

^{*4} from 5 MHz above or below the band edge increasing linearly to a level of 27 dBm/MHz at the band edge.

Note: The following formula is used to convert the equipment isotropic radiated power (eirp) to field strength:

$$E = \frac{1000000 \sqrt{30P}}{3} \mu\text{V/m, where } P \text{ is the eirp (Watts).}$$

6 Test Arrangements

6.1 26 dB Bandwidth

6.1.1 Test Setup

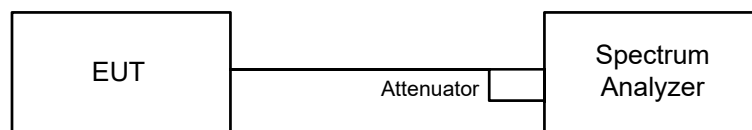

6.1.2 Test Procedure

- a. Set RBW = approximately 1% of the emission bandwidth.
- b. Set the VBW > RBW.
- c. Detector = Peak.
- d. Trace mode = max hold.
- e. Measure the maximum width of the emission that is 26 dB down from the peak of the emission. Compare this with the RBW setting of the analyzer. Readjust RBW and repeat measurement as needed until the RBW/EBW ratio is approximately 1%.

6.2 RF Output Power

6.2.1 Test Setup

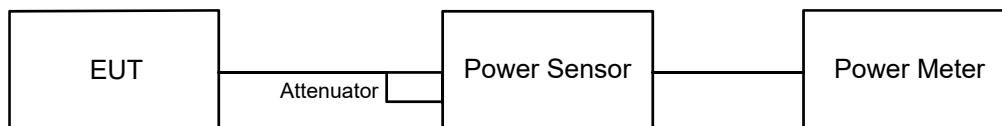

For channel straddling:

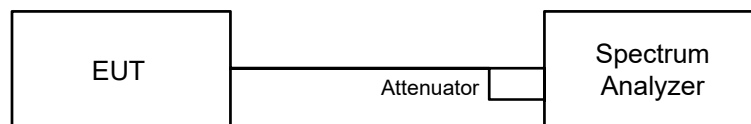

6.2.2 Test Procedure

Method PM is used to perform output power measurement, trigger and gating function of wide band power meter is enabled to measure max output power of TX on burst and set the detector to average. Duty factor is not added to measured value.

For channel straddling:

Method SA-1

- a. Set span to encompass the entire emission bandwidth (EBW) of the signal.
- b. Set RBW = 1 MHz, Set VBW \geq 3 MHz, Detector = RMS
- c. Sweep points \geq $[2 \times \text{span} / \text{RBW}]$. (This gives bin-to-bin spacing \leq RBW / 2, so that narrowband signals are not lost between frequency bins.)
- d. Sweep time = auto, trigger set to "free run".
- e. Trace average at least 100 traces in power averaging mode.
- f. Record the max value

Note: When measuring straddle channel power, use compute power by integrating the spectrum across the 26 dB EBW or 99% OBW of the signal using the instrument's band power measurement function, with band limits set equal to the EBW or OBW band edges. If the instrument does not have a band power function, then sum the spectrum levels (in power units) at 1 MHz intervals extending across the 26 dB EBW or 99% OBW of the spectrum.

6.3 Power Spectral Density

6.3.1 Test Setup

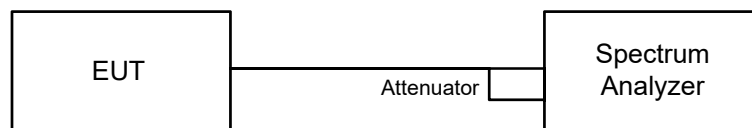

6.3.2 Test Procedure

For specified measurement bandwidth 1 MHz:

Method SA-1

- Set span to encompass the entire emission bandwidth (EBW) of the signal.
- Set RBW = 1 MHz, Set VBW \geq 3 MHz, Detector = RMS
- Sweep points \geq $[2 \times \text{span} / \text{RBW}]$. (This gives bin-to-bin spacing \leq RBW / 2, so that narrowband signals are not lost between frequency bins.)
- Sweep time = auto, trigger set to "free run".
- Trace average at least 100 traces in power averaging mode.
- Record the max value

For specified measurement bandwidth 500 kHz:

Method SA-1

- Set span to encompass the entire emission bandwidth (EBW) of the signal.
- Set RBW = 300 kHz, Set VBW \geq 1 MHz, Detector = RMS
- Scale the observed power level to an equivalent value in 500 kHz by adjusting (increasing) the measured power by a bandwidth correction factor (BWCF) where $\text{BWCF} = 10\log(500 \text{ kHz}/300 \text{ kHz})$
- Sweep points \geq $[2 \times \text{span} / \text{RBW}]$. (This gives bin-to-bin spacing \leq RBW / 2, so that narrowband signals are not lost between frequency bins.)
- Sweep time = auto, trigger set to "free run".
- Trace average at least 100 traces in power averaging mode.
- Record the max value

6.4 6 dB Bandwidth

6.4.1 Test Setup

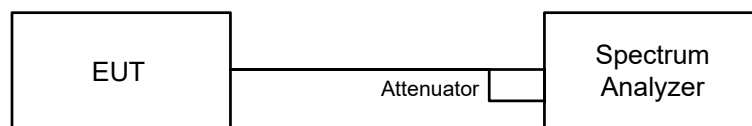

6.4.2 Test Procedure

- Set resolution bandwidth (RBW) = 100 kHz.
- Set the video bandwidth (VBW) \geq 3 x RBW, Detector = Peak.
- Trace mode = max hold.
- Sweep = auto couple.
- Measure the maximum width of the emission that is constrained by the frequencies associated with the two amplitude points (upper and lower) that are attenuated by 6 dB relative to the maximum level measured in the fundamental emission.

6.5 Occupied Bandwidth

6.5.1 Test Setup

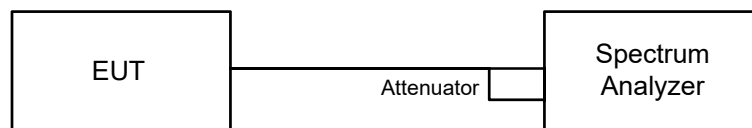

6.5.2 Test Procedure

The transmitter output was connected to the spectrum analyzer through an attenuator. The bandwidth of the fundamental frequency was measured by spectrum analyzer with resolution bandwidth in the range of 1% to 5% of the anticipated emission bandwidth, and a video bandwidth at least 3x the resolution bandwidth and set the detector to Sampling. The width of a frequency band such that, below the lower and above the upper frequency limits, the mean powers emitted are each equal to a specified percentage 0.5% of the total mean power of a given emission.

6.6 Frequency Stability

6.6.1 Test Setup

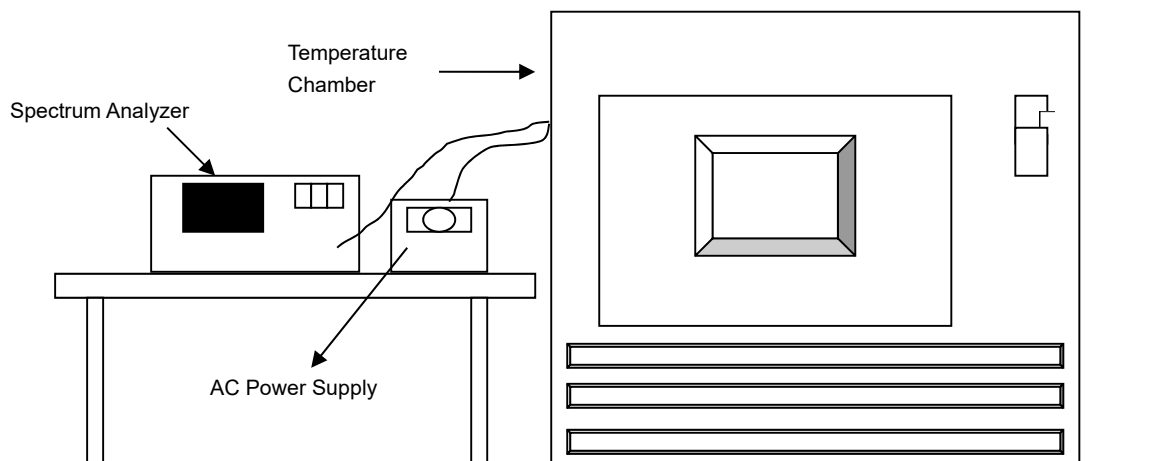

6.6.2 Test Procedure

- The EUT was placed inside the environmental test chamber and powered by nominal AC voltage.
- Turn the EUT on and couple its output to a spectrum analyzer.
- Turn the EUT off and set the chamber to the highest temperature specified.
- Allow sufficient time (approximately 30 min) for the temperature of the chamber to stabilize, turn the EUT on and measure the operating frequency after 2, 5, and 10 Minutes.
- Repeat step (d) with the temperature chamber set to the next desired temperature until measurements down to the lowest specified temperature have been completed.
- The test chamber was allowed to stabilize at +20 degree C for a minimum of 30 Minutes. The supply voltage was then adjusted on the EUT from 85% to 115% and the frequency record.

6.7 AC Power Conducted Emissions

6.7.1 Test Setup

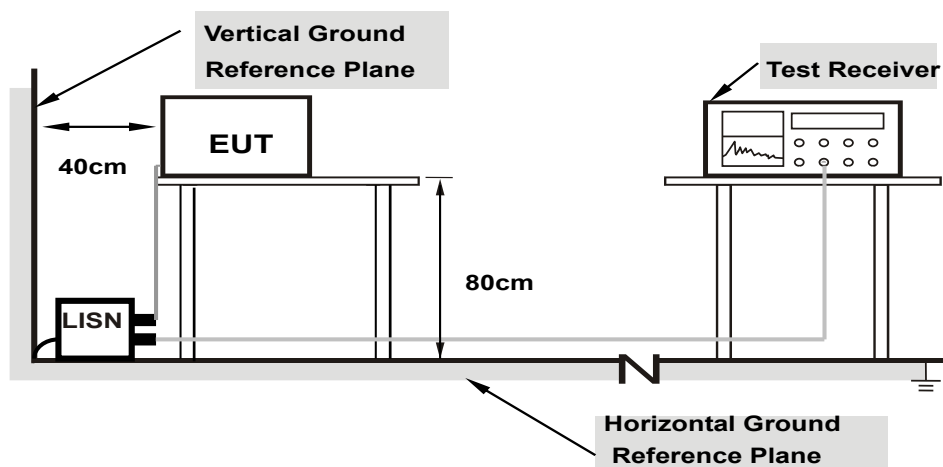

Note: 1.Support units were connected to second LISN.

For the actual test configuration, please refer to the attached file (Test Setup Photo).

6.7.2 Test Procedure

- The EUT was placed on a 0.8 meter to the top of table and placed 0.4 meters from the conducting wall of the shielded room with EUT being connected to the power mains through a line impedance stabilization network (LISN). Other support units were connected to the power mains through another LISN. The two LISNs provide 50 ohm/ 50 uH of coupling impedance for the measuring instrument.
- Both lines of the power mains connected to the EUT were checked for maximum conducted interference.
- The frequency range from 150 kHz to 30 MHz was searched. Emission levels under (Limit – 20 dB) was not recorded.

Note: The resolution bandwidth and video bandwidth of test receiver is 9 kHz for quasi-peak detection (QP) and average detection (AV) at frequency 0.15 MHz-30 MHz.

6.8 Unwanted Emissions below 1 GHz

6.8.1 Test Setup

For Radiated emission below 30 MHz

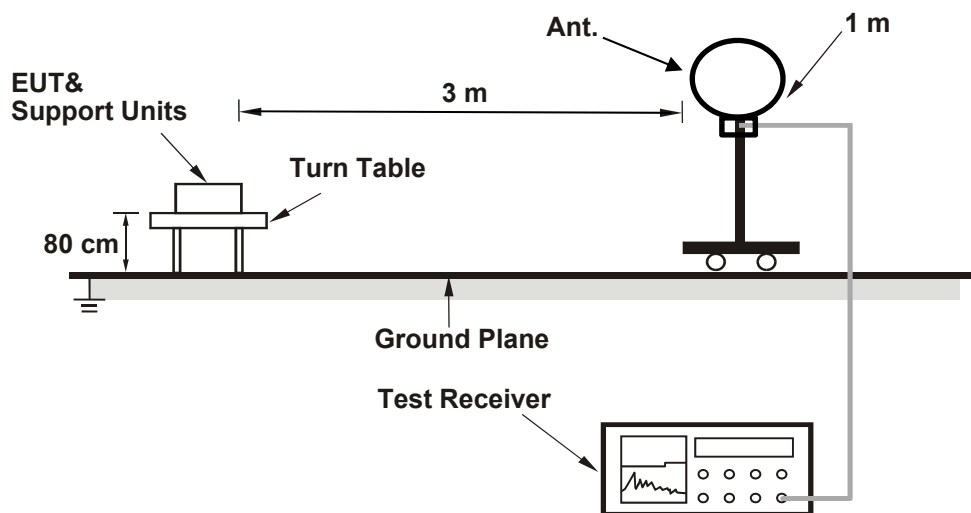

For Radiated emission above 30 MHz

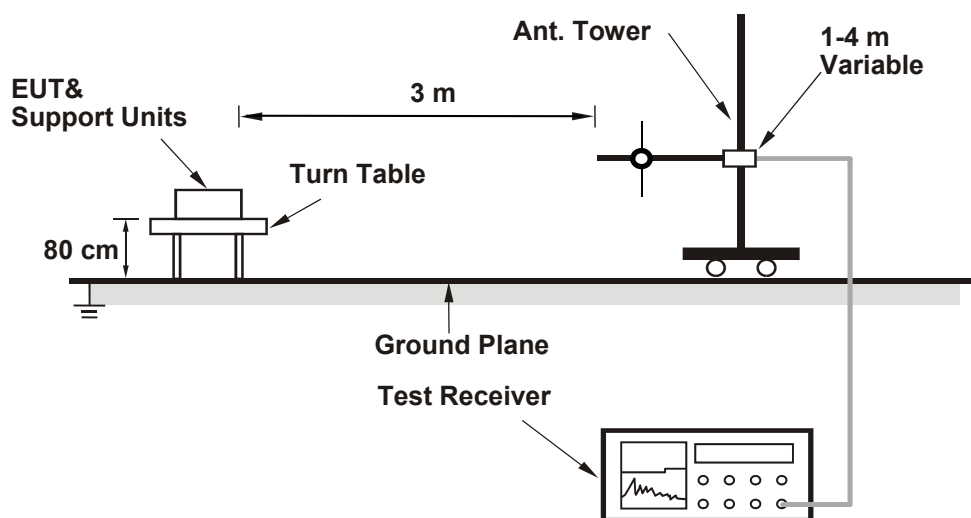

For the actual test configuration, please refer to the attached file (Test Setup Photo).

6.8.2 Test Procedure

For Radiated emission below 30 MHz

- a. The EUT was placed on the top of a rotating table 0.8 meters above the ground at 3 meter chamber room for test. The table was rotated 360 degrees to determine the position of the highest radiation.
- b. The EUT was set 3 meters away from the interference-receiving antenna, which was mounted on the top of a variable-height antenna tower.
- c. Parallel, perpendicular, and ground-parallel orientations of the antenna are set to make the measurement.
- d. For each suspected emission, the EUT was arranged to its worst case and the rotatable table was turned from 0 degrees to 360 degrees to find the maximum reading.
- e. The test-receiver system was set to Quasi-Peak Detect Function and Specified Bandwidth with Maximum Hold Mode, except for the frequency band (9 kHz to 90 kHz and 110 kHz to 490 kHz) set to average detect function and peak detect function.

Notes:

1. The resolution bandwidth and video bandwidth of test receiver/spectrum analyzer is 200 Hz at frequency below 150 kHz.
2. The resolution bandwidth and video bandwidth of test receiver/spectrum analyzer is 9 kHz or 10 kHz at frequency (150 kHz to 30 MHz).
3. All modes of operation were investigated and the worst-case emissions are reported.

For Radiated emission above 30 MHz

- a. The EUT was placed on the top of a rotating table 0.8 meters above the ground at 3 meter chamber room for test. The table was rotated 360 degrees to determine the position of the highest radiation.
- b. The EUT was set 3 meters away from the interference-receiving antenna, which was mounted on the top of a variable-height antenna tower.
- c. The height of antenna is varied from one meter to four meters above the ground to determine the maximum value of the field strength. Both horizontal and vertical polarizations of the antenna are set to make the measurement.
- d. For each suspected emission, the EUT was arranged to its worst case and then the antenna was tuned to heights from 1 meter to 4 meters and the rotatable table was turned from 0 degrees to 360 degrees to find the maximum reading.
- e. The test-receiver system was set to quasi-peak detect function and specified bandwidth with maximum hold mode when the test frequency is below 1 GHz.

Notes:

1. The resolution bandwidth and video bandwidth of test receiver/spectrum analyzer is 120 kHz for Quasi-peak detection (QP) at frequency below 1 GHz.
2. All modes of operation were investigated and the worst-case emissions are reported.

6.9 Unwanted Emissions above 1 GHz

6.9.1 Test Setup

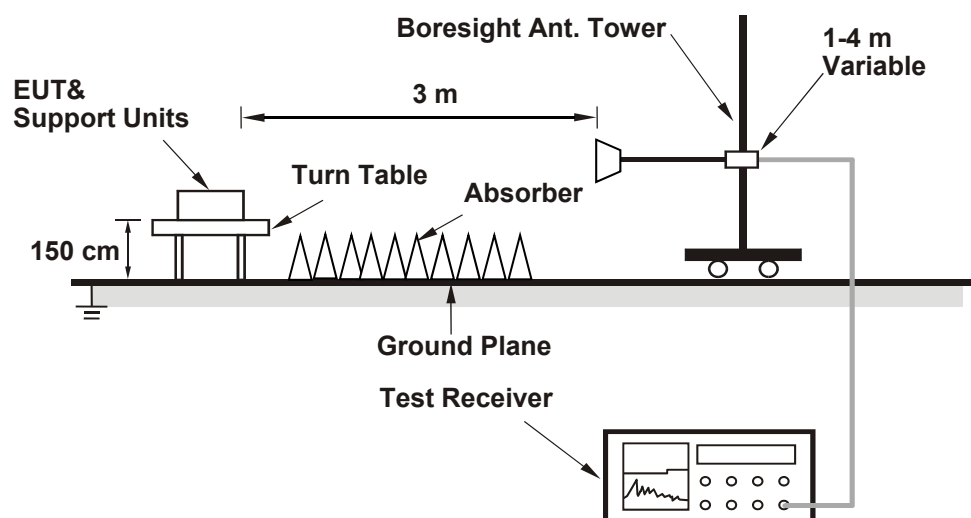

For the actual test configuration, please refer to the attached file (Test Setup Photo).

6.9.2 Test Procedure

- The EUT was placed on the top of a rotating table 1.5 meters above the ground at 3 meter chamber room for test. The table was rotated 360 degrees to determine the position of the highest radiation.
- The EUT was set 3 meters away from the interference-receiving antenna, which was mounted on the top of a variable-height antenna tower.
- The height of antenna is varied from one meter to four meters above the ground to determine the maximum value of the field strength. Both horizontal and vertical polarizations of the antenna are set to make the measurement.
- For each suspected emission, the EUT was arranged to its worst case and then the antenna was tuned to heights from 1 meter to 4 meters and the rotatable table was turned from 0 degrees to 360 degrees to find the maximum reading.
- The test-receiver system was set to peak and average detects function and specified bandwidth with maximum hold mode when the test frequency is above 1 GHz. If the peak reading value also meets average limit, measurement with the average detector is unnecessary.

Notes:

- The resolution bandwidth of test receiver/spectrum analyzer is 1 MHz and the video bandwidth is 3 MHz for Peak detection (PK) and Average detection (AV) at frequency above 1 GHz.
- For fundamental and harmonic signal measurement, the resolution bandwidth of test receiver/spectrum analyzer is 1 MHz and the video bandwidth is $\geq 1/T$ (Duty cycle $< 98\%$) or 10 Hz (Duty cycle $\geq 98\%$) for Average detection (AV) at frequency above 1 GHz.
- All modes of operation were investigated and the worst-case emissions are reported.

7 Test Results of Test Item

7.1 26 dB Bandwidth

Input Power:	120 Vac, 60 Hz	Environmental Conditions:	25°C, 60% RH	Tested By:	John Peng
--------------	----------------	---------------------------	--------------	------------	-----------

802.11a

Channel	Frequency (MHz)	26 dB Bandwidth (MHz)	
		Chain 0	Chain 1
52	5260	22.66	22.05
60	5300	22.24	22.18
64	5320	22.27	23.52
100	5500	22.05	21.99
116	5580	21.93	21.70
140	5700	21.47	21.21
144 (U-NII-2C)	5720	16.03	15.88
144 (U-NII-3)	5720	5.92	5.78

Determined Output Power Limit			
Channel Number	Freq.(MHz)	Min. B(MHz)	Determined Conducted Power Limit (dBm)
52	5260	22.05	24.43 > 24
60	5300	22.18	24.45 > 24
64	5320	22.27	24.47 > 24
100	5500	21.99	24.42 > 24
116	5580	21.70	24.36 > 24
140	5700	21.21	24.26 > 24
144 (U-NII-2C)	5720	15.88	23 < 24

Note: For U-NII-2A, U-NII-2C Band output power limitation is determined based on 26dBc bandwidth.

802.11ax (HE20)

Channel	Frequency (MHz)	26 dB Bandwidth (MHz)	
		Chain 0	Chain 1
52	5260	24.91	21.98
60	5300	23.06	24.52
64	5320	25.00	26.52
100	5500	25.51	24.38
116	5580	21.99	22.16
140	5700	21.79	21.56
144 (U-NII-2C)	5720	16.71	15.82
144 (U-NII-3)	5720	6.06	5.92

Determined Output Power Limit			
Channel Number	Freq.(MHz)	Min. B(MHz)	Determined Conducted Power Limit (dBm)
52	5260	21.98	24.42 > 24
60	5300	23.06	24.62 > 24
64	5320	25.00	24.97 > 24
100	5500	24.38	24.87 > 24
116	5580	21.99	24.42 > 24
140	5700	21.56	24.33 > 24
144 (U-NII-2C)	5720	15.82	22.99 < 24

Note: For U-NII-2A, U-NII-2C Band output power limitation is determined based on 26dBc bandwidth.

802.11ax (HE40)

Channel	Frequency (MHz)	26 dB Bandwidth (MHz)	
		Chain 0	Chain 1
54	5270	45.26	43.47
62	5310	47.33	45.99
102	5510	47.79	45.43
110	5550	46.69	43.03
134	5670	43.19	41.10
142 (U-NII-2C)	5710	35.97	38.70
142 (U-NII-3)	5710	7.69	7.43

Determined Output Power Limit			
Channel Number	Freq.(MHz)	Min. B(MHz)	Determined Conducted Power Limit (dBm)
54	5270	43.47	27.38 > 24
62	5310	45.99	27.62 > 24
102	5510	45.43	27.57 > 24
110	5550	43.03	27.33 > 24
134	5670	41.10	27.13 > 24
142 (U-NII-2C)	5710	35.97	26.55 > 24

Note: For U-NII-2A, U-NII-2C Band output power limitation is determined based on 26dBc bandwidth.

802.11ax (HE80)

Channel	Frequency (MHz)	26 dB Bandwidth (MHz)	
		Chain 0	Chain 1
58	5290	83.21	83.52
106	5530	84.94	83.47
122	5610	82.17	82.59
138 (U-NII-2C)	5690	75.70	75.57
138 (U-NII-3)	5690	6.03	5.49

Determined Output Power Limit			
Channel Number	Freq.(MHz)	Min. B(MHz)	Determined Conducted Power Limit (dBm)
58	5290	83.21	30.2 > 24
106	5530	83.47	30.21 > 24
122	5610	82.17	30.14 > 24
138 (U-NII-2C)	5690	75.57	29.78 > 24

Note: For U-NII-2A, U-NII-2C Band output power limitation is determined based on 26dBc bandwidth.

802.11ax (HE160)

Channel	Frequency (MHz)	26 dB Bandwidth (MHz)	
		Chain 0	Chain 1
50 (U-NII-1)	5250	82.79	83.08
50 (U-NII-2A)	5250	83.04	83.19
114	5570	167.34	166.32

Determined Output Power Limit			
Channel Number	Freq.(MHz)	Min. B(MHz)	Determined Conducted Power Limit (dBm)
50 (U-NII-2A)	5250	83.04	30.19 > 24
114	5570	166.32	33.2 > 24

Note: For U-NII-2A, U-NII-2C Band output power limitation is determined based on 26dBc bandwidth.



Spectrum Plot of Minimum Value

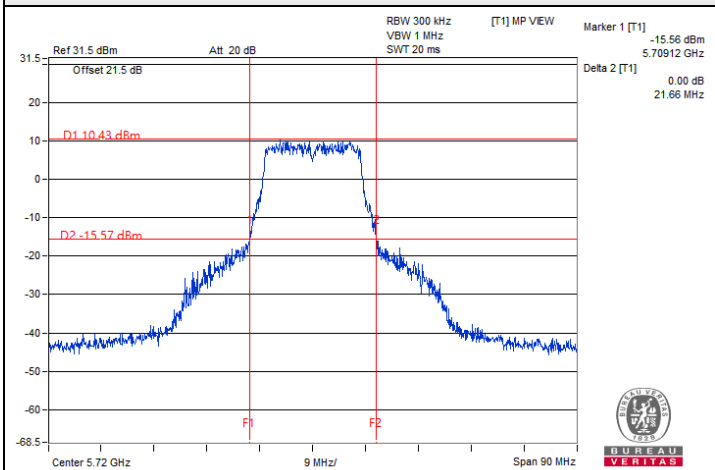

802.11a / Chain 1 : CH 144 (U-NII-3)

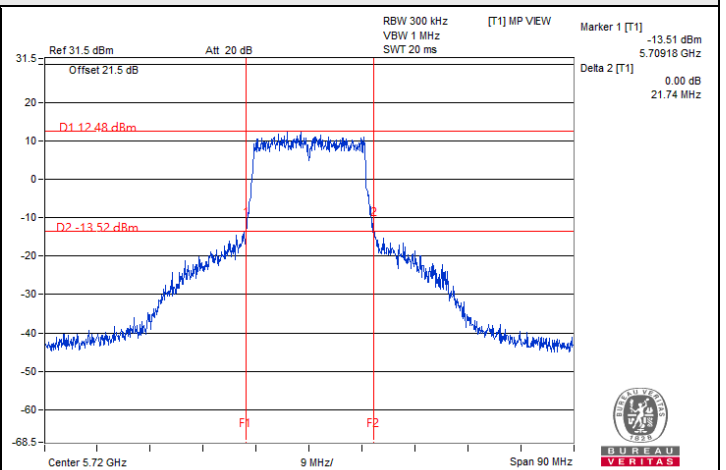

802.11ax (HE20) / Chain 1 : CH 144 (U-NII-3)

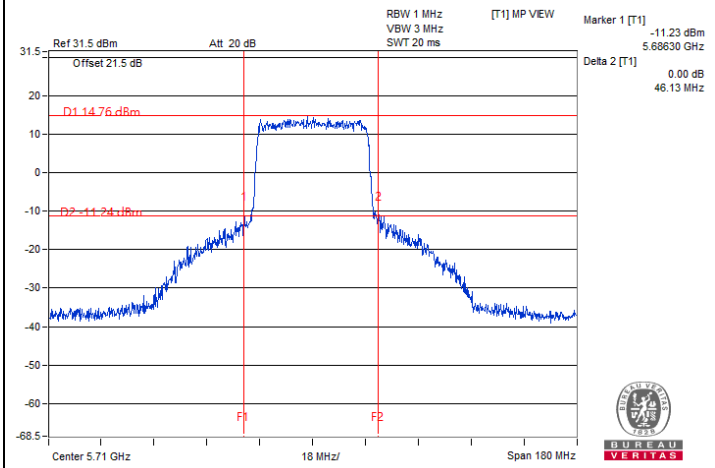

802.11ax (HE40) / Chain 1 : CH 142 (U-NII-3)

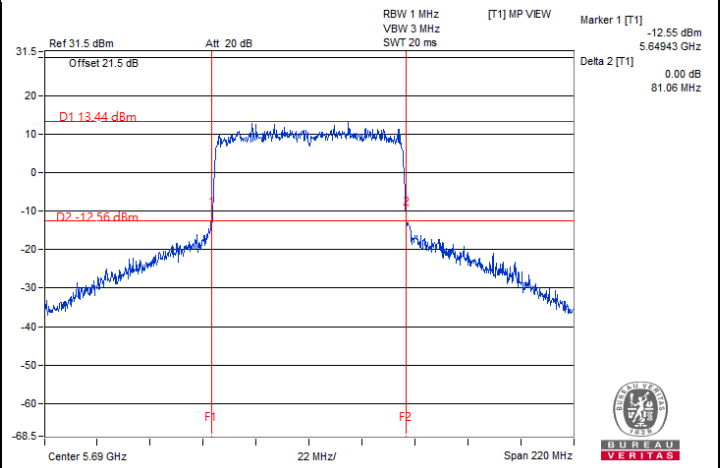

802.11ax (HE80) / Chain 1 : CH 138 (U-NII-3)

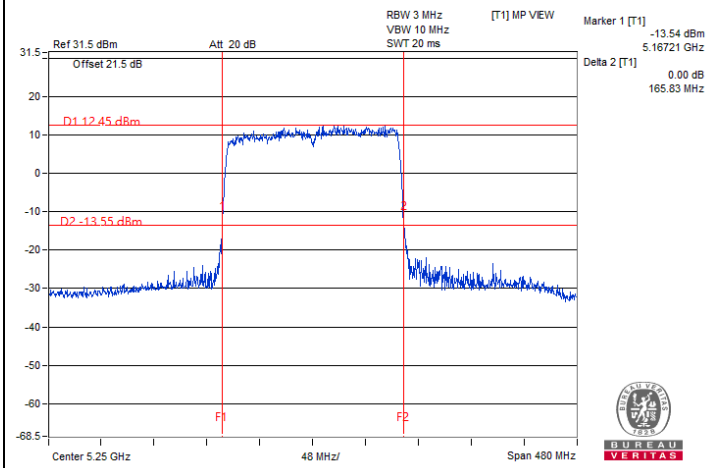

802.11ax (HE160) / Chain 0 : CH 50 (U-NII-1)

Notes:

1. For U-NII-2C straddle channel = 5725 MHz - Marker 1
2. For U-NII-3 straddle channel = Marker 1 + Delta 2 - 5725 MHz

7.2 RF Output Power

Input Power:	120 Vac, 60 Hz	Environmental Conditions:	25°C, 60% RH	Tested By:	John Peng
--------------	----------------	---------------------------	--------------	------------	-----------

802.11a CDD

Chan.	Chan. Freq. (MHz)	Average Power (dBm)		Total Power (mW)	Total Power (dBm)	Power Limit (dBm)	Test Result
		Chain 0	Chain 1				
36	5180	22.72	22.33	358.07	25.54	30	Pass
40	5200	26.02	25.18	729.554	28.63	30	Pass
48	5240	24.11	22.95	454.874	26.58	30	Pass
52	5260	21.67	20.05	248.051	23.95	24	Pass
60	5300	21.72	20.02	249.055	23.96	24	Pass
64	5320	21.70	19.97	247.222	23.93	24	Pass
100	5500	21.28	20.47	245.706	23.90	24	Pass
116	5580	21.18	20.53	244.2	23.88	24	Pass
140	5700	19.23	18.57	155.698	21.92	24	Pass
*144 (U-NII-2C)	5720	20.21	19.59	195.946	22.92	23	Pass
*144 (U-NII-3)	5720	14.05	13.51	47.849	16.80	30	Pass
149	5745	26.68	25.78	844.029	29.26	30	Pass
157	5785	26.97	26.03	898.604	29.54	30	Pass
165	5825	26.67	25.86	849.994	29.29	30	Pass

Notes:

- * : Test was performed in accordance with measurement follow FCC KDB 789033 UNII test procedure Method SA-1 and use spectrum analyzer test.
- Directional gain is the maximum gain of antennas.
- For U-NII-1, the maximum gain is 2.49 dBi < 6 dBi, so the output power limit shall not be reduced.
- For U-NII-2A, the maximum gain is 2.49 dBi < 6 dBi, so the output power limit shall not be reduced.
- For U-NII-2C, the maximum gain is 2.81 dBi < 6 dBi, so the output power limit shall not be reduced.
- For U-NII-3, the maximum gain is 2.69 dBi < 6 dBi, so the output power limit shall not be reduced.

802.11ax (HE20) CDD

Chan.	Chan. Freq. (MHz)	Average Power (dBm)		Total Power (mW)	Total Power (dBm)	Power Limit (dBm)	Test Result
		Chain 0	Chain 1				
36	5180	23.35	22.27	384.927	25.85	30	Pass
40	5200	25.82	24.63	672.347	28.28	30	Pass
48	5240	24.44	23.17	485.463	26.86	30	Pass
52	5260	21.65	20.08	248.077	23.95	24	Pass
60	5300	21.75	19.93	248.025	23.94	24	Pass
64	5320	21.83	19.71	245.946	23.91	24	Pass
100	5500	21.03	20.44	237.428	23.76	24	Pass
116	5580	20.96	20.68	241.688	23.83	24	Pass
140	5700	18.89	18.33	145.523	21.63	24	Pass
*144 (U-NII-2C)	5720	19.89	19.42	184.997	22.67	22.99	Pass
*144 (U-NII-3)	5720	14.70	14.15	55.514	17.44	30	Pass
149	5745	26.78	25.85	861.023	29.35	30	Pass
157	5785	27.02	26.22	922.294	29.65	30	Pass
165	5825	26.57	25.79	833.257	29.21	30	Pass

Notes:

1. * : Test was performed in accordance with measurement follow FCC KDB 789033 UNII test procedure Method SA-1 and use spectrum analyzer test.
2. Directional gain is the maximum gain of antennas.
3. For U-NII-1, the maximum gain is 2.49 dBi < 6 dBi, so the output power limit shall not be reduced.
4. For U-NII-2A, the maximum gain is 2.49 dBi < 6 dBi, so the output power limit shall not be reduced.
5. For U-NII-2C, the maximum gain is 2.81 dBi < 6 dBi, so the output power limit shall not be reduced.
6. For U-NII-3, the maximum gain is 2.69 dBi < 6 dBi, so the output power limit shall not be reduced.

802.11ax (HE40) CDD

Chan.	Chan. Freq. (MHz)	Average Power (dBm)		Total Power (mW)	Total Power (dBm)	Power Limit (dBm)	Test Result
		Chain 0	Chain 1				
38	5190	20.33	19.13	189.741	22.78	30	Pass
46	5230	24.88	23.86	550.83	27.41	30	Pass
54	5270	21.26	20.54	246.9	23.93	24	Pass
62	5310	19.33	18.32	153.624	21.86	24	Pass
102	5510	21.15	20.14	233.593	23.68	24	Pass
110	5550	21.13	20.37	238.611	23.78	24	Pass
134	5670	21.22	20.28	239.094	23.79	24	Pass
*142 (U-NII-2C)	5710	19.92	19.64	190.22	22.79	24	Pass
*142 (U-NII-3)	5710	10.28	9.91	20.461	13.11	30	Pass
151	5755	25.39	25.51	701.571	28.46	30	Pass
159	5795	26.32	26.05	831.266	29.20	30	Pass

Notes:

- * : Test was performed in accordance with measurement follow FCC KDB 789033 UNII test procedure Method SA-1 and use spectrum analyzer test.
- Directional gain is the maximum gain of antennas.
- For U-NII-1, the maximum gain is 2.49 dBi < 6 dBi, so the output power limit shall not be reduced.
- For U-NII-2A, the maximum gain is 2.49 dBi < 6 dBi, so the output power limit shall not be reduced.
- For U-NII-2C, the maximum gain is 2.81 dBi < 6 dBi, so the output power limit shall not be reduced.
- For U-NII-3, the maximum gain is 2.69 dBi < 6 dBi, so the output power limit shall not be reduced.

802.11ax (HE80) CDD

Chan.	Chan. Freq. (MHz)	Average Power (dBm)		Total Power (mW)	Total Power (dBm)	Power Limit (dBm)	Test Result
		Chain 0	Chain 1				
42	5210	19.86	18.32	164.748	22.17	30	Pass
58	5290	19.27	17.98	147.334	21.68	24	Pass
106	5530	20.92	19.94	222.223	23.47	24	Pass
122	5610	21.41	20.33	246.251	23.91	24	Pass
*138 (U-NII-2C)	5690	20.06	19.41	188.688	22.76	24	Pass
*138 (U-NII-3)	5690	6.79	6.25	8.992	9.54	30	Pass
155	5775	23.51	22.85	417.141	26.20	30	Pass

Notes:

- * : Test was performed in accordance with measurement follow FCC KDB 789033 UNII test procedure Method SA-1 and use spectrum analyzer test.
- Directional gain is the maximum gain of antennas.
- For U-NII-1, the maximum gain is 2.49 dBi < 6 dBi, so the output power limit shall not be reduced.
- For U-NII-2A, the maximum gain is 2.49 dBi < 6 dBi, so the output power limit shall not be reduced.
- For U-NII-2C, the maximum gain is 2.81 dBi < 6 dBi, so the output power limit shall not be reduced.
- For U-NII-3, the maximum gain is 2.69 dBi < 6 dBi, so the output power limit shall not be reduced.

802.11ax (HE160) CDD

Chan.	Chan. Freq. (MHz)	Average Power (dBm)		Total Power (mW)	Total Power (dBm)	Power Limit (dBm)	Test Result
		Chain 0	Chain 1				
*50 (U-NII-1)	5250	15.66	15.35	71.09	18.52	30	Pass
*50 (U-NII-2A)	5250	16.68	16.65	92.797	19.68	24	Pass
114	5570	18.09	17.68	123.031	20.90	24	Pass

Notes:

- * : Test was performed in accordance with measurement follow FCC KDB 789033 UNII test procedure Method SA-1 and use spectrum analyzer test.
- Directional gain is the maximum gain of antennas.
- For U-NII-1, the maximum gain is 2.49 dBi < 6 dBi, so the output power limit shall not be reduced.
- For U-NII-2A, the maximum gain is 2.49 dBi < 6 dBi, so the output power limit shall not be reduced.
- For U-NII-2C, the maximum gain is 2.81 dBi < 6 dBi, so the output power limit shall not be reduced.

802.11ax (HE20) Beamforming

Chan.	Chan. Freq. (MHz)	Average Power (dBm)		Total Power (mW)	Total Power (dBm)	Power Limit (dBm)	Test Result
		Chain 0	Chain 1				
36	5180	23.35	22.27	384.927	25.85	30	Pass
40	5200	25.82	24.63	672.347	28.28	30	Pass
48	5240	24.44	23.17	485.463	26.86	30	Pass
52	5260	21.65	20.08	248.077	23.95	24	Pass
60	5300	21.75	19.93	248.025	23.94	24	Pass
64	5320	21.83	19.71	245.946	23.91	24	Pass
100	5500	21.03	20.44	237.428	23.76	24	Pass
116	5580	20.96	20.68	241.688	23.83	24	Pass
140	5700	18.89	18.33	145.523	21.63	24	Pass
*144 (U-NII-2C)	5720	19.89	19.42	184.997	22.67	22.99	Pass
*144 (U-NII-3)	5720	14.70	14.15	55.514	17.44	30	Pass
149	5745	26.78	25.85	861.023	29.35	30	Pass
157	5785	27.02	26.22	922.294	29.65	30	Pass
165	5825	26.57	25.79	833.257	29.21	30	Pass

Notes:

- * : Test was performed in accordance with measurement follow FCC KDB 789033 UNII test procedure Method SA-1 and use spectrum analyzer test.
- Directional gain = $10 \log[(10^{\text{Chain0}/20} + 10^{\text{Chain1}/20})^2 / 2]$
- For U-NII-1, the directional gain is 5.45 dBi < 6 dBi, so the output power limit shall not be reduced.
- For U-NII-2A, the directional gain is 5.45 dBi < 6 dBi, so the output power limit shall not be reduced.
- For U-NII-2C, the directional gain is 5.74 dBi < 6 dBi, so the output power limit shall not be reduced.
- For U-NII-3, the directional gain is 5.63 dBi < 6 dBi, so the output power limit shall not be reduced.

802.11ax (HE40) Beamforming

Chan.	Chan. Freq. (MHz)	Average Power (dBm)		Total Power (mW)	Total Power (dBm)	Power Limit (dBm)	Test Result
		Chain 0	Chain 1				
38	5190	20.33	19.13	189.741	22.78	30	Pass
46	5230	24.88	23.86	550.83	27.41	30	Pass
54	5270	21.26	20.54	246.9	23.93	24	Pass
62	5310	19.33	18.32	153.624	21.86	24	Pass
102	5510	21.15	20.14	233.593	23.68	24	Pass
110	5550	21.13	20.37	238.611	23.78	24	Pass
134	5670	21.22	20.28	239.094	23.79	24	Pass
*142 (U-NII-2C)	5710	19.92	19.64	190.22	22.79	24	Pass
*142 (U-NII-3)	5710	10.28	9.91	20.461	13.11	30	Pass
151	5755	25.39	25.51	701.571	28.46	30	Pass
159	5795	26.32	26.05	831.266	29.20	30	Pass

Notes:

- * : Test was performed in accordance with measurement follow FCC KDB 789033 UNII test procedure Method SA-1 and use spectrum analyzer test.
- Directional gain = $10 \log[(10^{\text{Chain0}/20} + 10^{\text{Chain1}/20})^2 / 2]$
- For U-NII-1, the directional gain is 5.45 dBi < 6 dBi, so the output power limit shall not be reduced.
- For U-NII-2A, the directional gain is 5.45 dBi < 6 dBi, so the output power limit shall not be reduced.
- For U-NII-2C, the directional gain is 5.74 dBi < 6 dBi, so the output power limit shall not be reduced.
- For U-NII-3, the directional gain is 5.63 dBi < 6 dBi, so the output power limit shall not be reduced.

802.11ax (HE80) Beamforming

Chan.	Chan. Freq. (MHz)	Average Power (dBm)		Total Power (mW)	Total Power (dBm)	Power Limit (dBm)	Test Result
		Chain 0	Chain 1				
42	5210	19.86	18.32	164.748	22.17	30	Pass
58	5290	19.27	17.98	147.334	21.68	24	Pass
106	5530	20.92	19.94	222.223	23.47	24	Pass
122	5610	21.41	20.33	246.251	23.91	24	Pass
*138 (U-NII-2C)	5690	20.06	19.41	188.688	22.76	24	Pass
*138 (U-NII-3)	5690	6.79	6.25	8.992	9.54	30	Pass
155	5775	23.51	22.85	417.141	26.20	30	Pass

Notes:

- * : Test was performed in accordance with measurement follow FCC KDB 789033 UNII test procedure Method SA-1 and use spectrum analyzer test.
- Directional gain = $10 \log[(10^{\text{Chain0}/20} + 10^{\text{Chain1}/20})^2 / 2]$
- For U-NII-1, the directional gain is 5.45 dBi < 6 dBi, so the output power limit shall not be reduced.
- For U-NII-2A, the directional gain is 5.45 dBi < 6 dBi, so the output power limit shall not be reduced.
- For U-NII-2C, the directional gain is 5.74 dBi < 6 dBi, so the output power limit shall not be reduced.
- For U-NII-3, the directional gain is 5.63 dBi < 6 dBi, so the output power limit shall not be reduced.

802.11ax (HE160) Beamforming

Chan.	Chan. Freq. (MHz)	Average Power (dBm)		Total Power (mW)	Total Power (dBm)	Power Limit (dBm)	Test Result
		Chain 0	Chain 1				
*50 (U-NII-1)	5250	15.66	15.35	71.09	18.52	30	Pass
*50 (U-NII-2A)	5250	16.68	16.65	92.797	19.68	24	Pass
114	5570	18.09	17.68	123.031	20.90	24	Pass

Notes:

1. * : Test was performed in accordance with measurement follow FCC KDB 789033 UNII test procedure Method SA-1 and use spectrum analyzer test.
2. Directional gain is the maximum gain of antennas.
3. For U-NII-1, the maximum gain is 5.45 dBi < 6 dBi, so the output power limit shall not be reduced.
4. For U-NII-2A, the maximum gain is 5.45 dBi < 6 dBi, so the output power limit shall not be reduced.
5. For U-NII-2C, the maximum gain is 5.74 dBi < 6 dBi, so the output power limit shall not be reduced.



Spectrum Plot for channel straddling

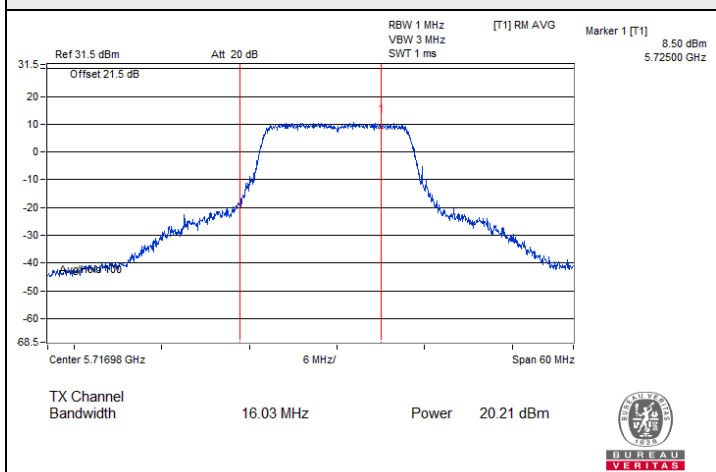

802.11a CDD / Chain 0 : CH 144 (U-NII-2C)

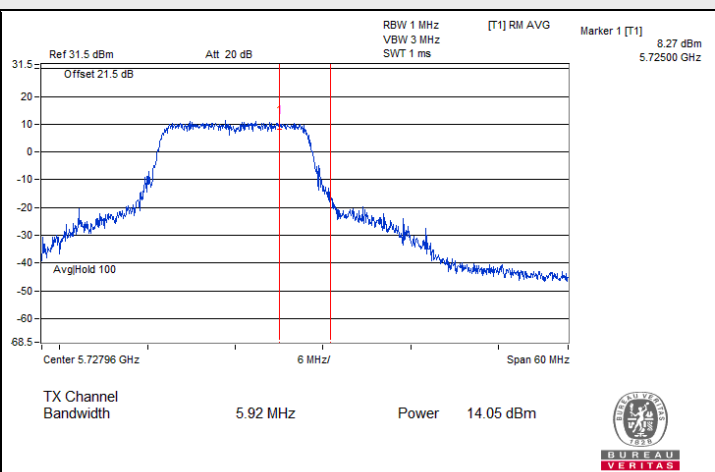

802.11a CDD / Chain 0 : CH 144 (U-NII-3)

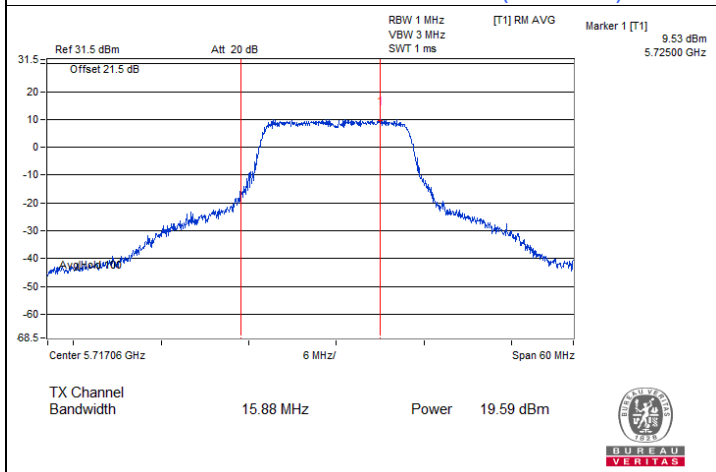

802.11a CDD / Chain 1 : CH 144 (U-NII-2C)

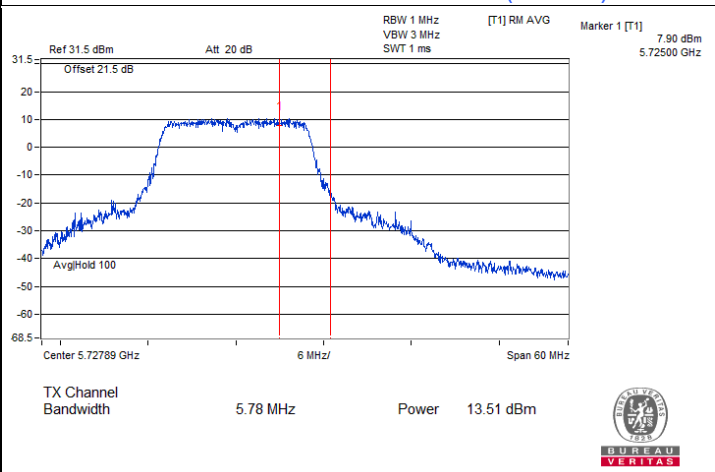

802.11a CDD / Chain 1 : CH 144 (U-NII-3)

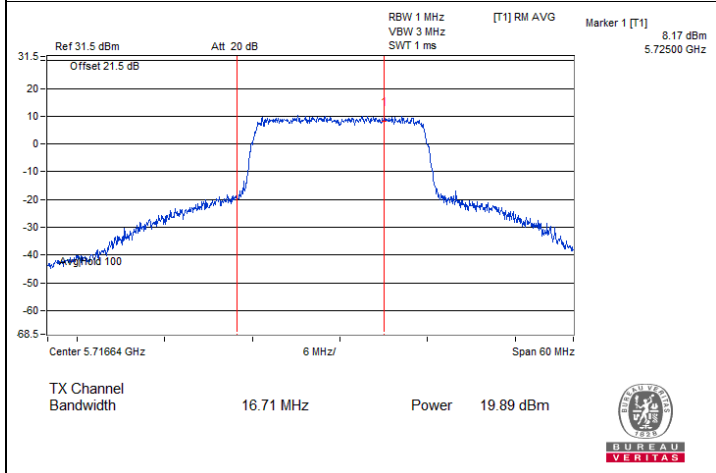

802.11ax (HE20) CDD / Chain 0 : CH 144 (U-NII-2C)

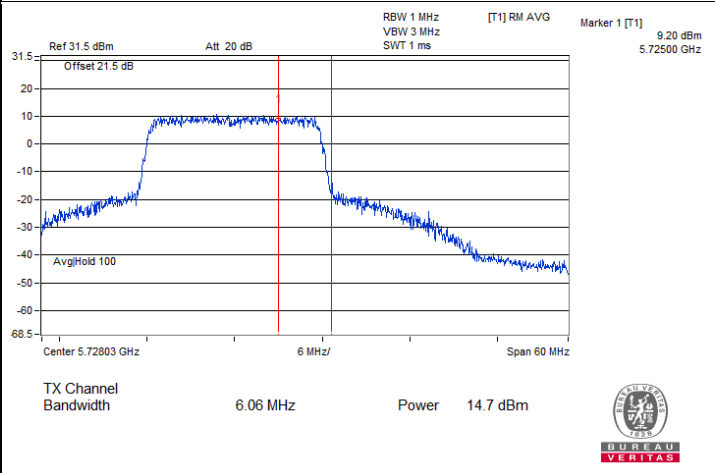

802.11ax (HE20) CDD / Chain 0 : CH 144 (U-NII-3)



Spectrum Plot for channel straddling

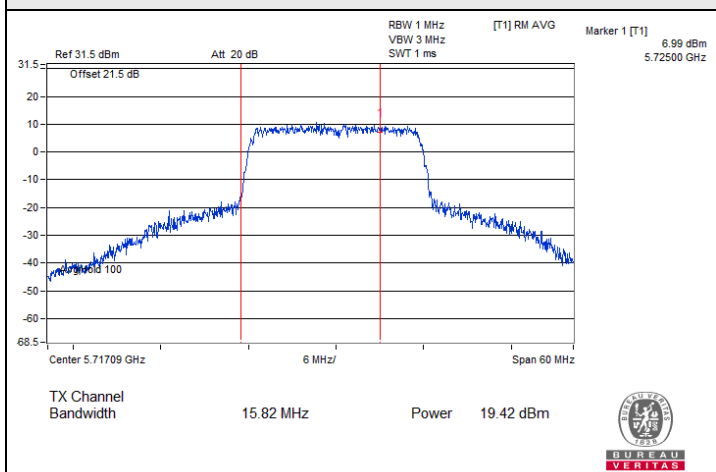

802.11ax (HE20) CDD / Chain 1 : CH 144 (U-NII-2C)

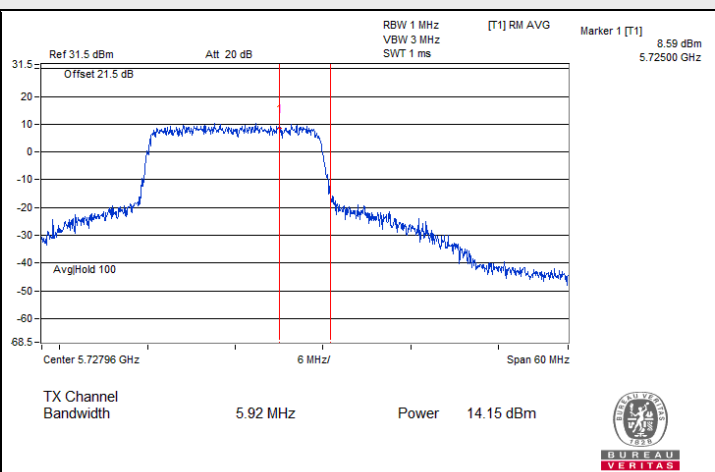

802.11ax (HE20) CDD / Chain 1 : CH 144 (U-NII-3)

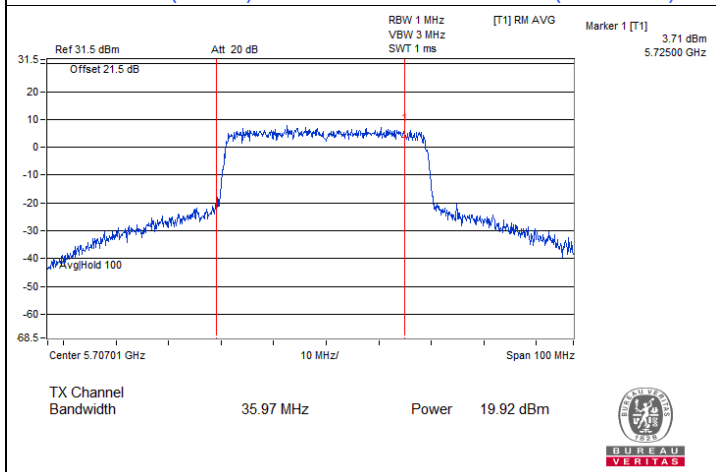

802.11ax (HE40) CDD / Chain 0 : CH 142 (U-NII-2C)

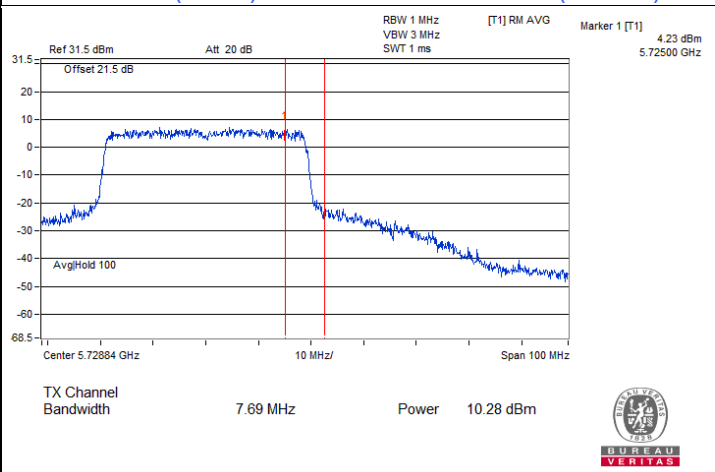

802.11ax (HE40) CDD / Chain 0 : CH 142 (U-NII-3)

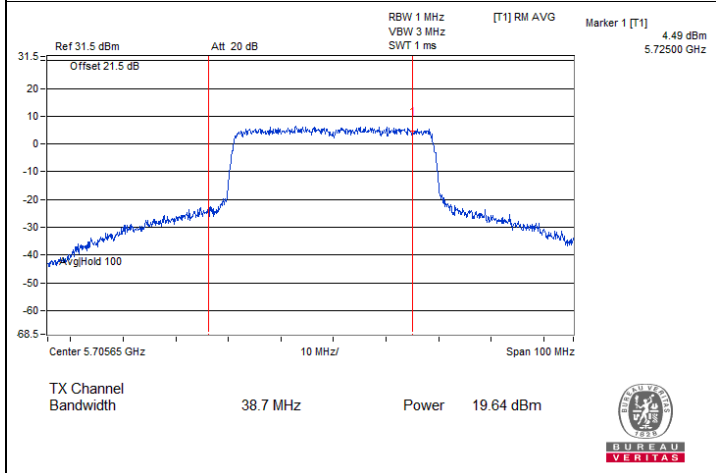

802.11ax (HE40) CDD / Chain 1 : CH 142 (U-NII-2C)

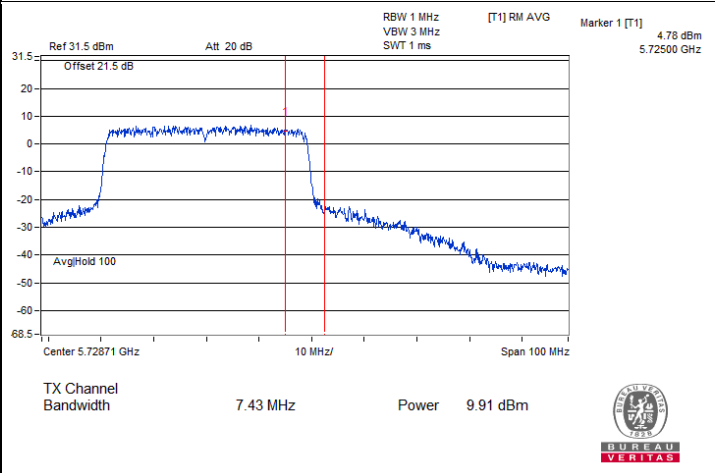

802.11ax (HE40) CDD / Chain 1 : CH 142 (U-NII-3)



Spectrum Plot for channel straddling

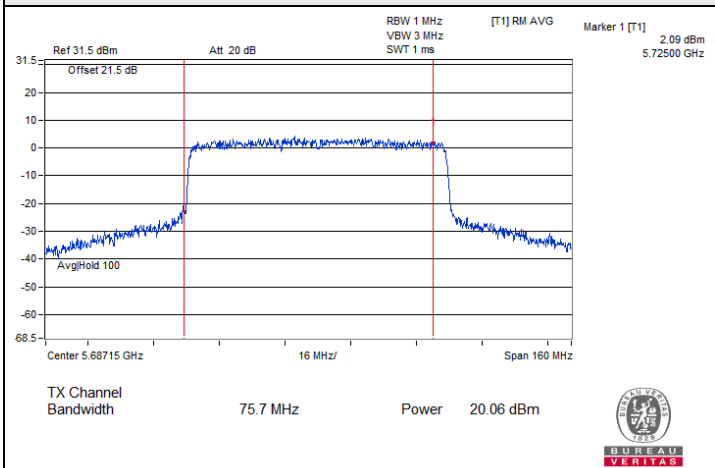

802.11ax (HE80) CDD / Chain 0 : CH 138 (U-NII-2C)

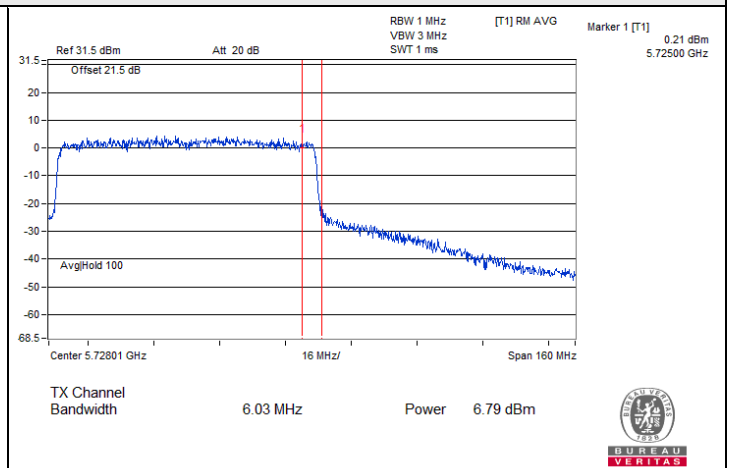

802.11ax (HE80) CDD / Chain 0 : CH 138 (U-NII-3)

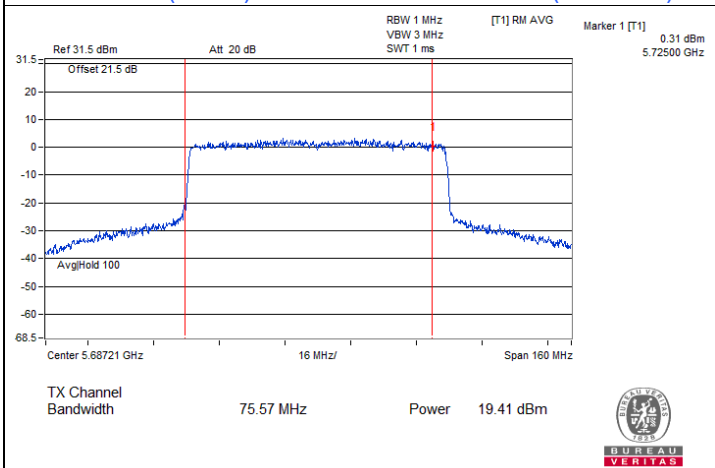

802.11ax (HE80) CDD / Chain 1 : CH 138 (U-NII-2C)

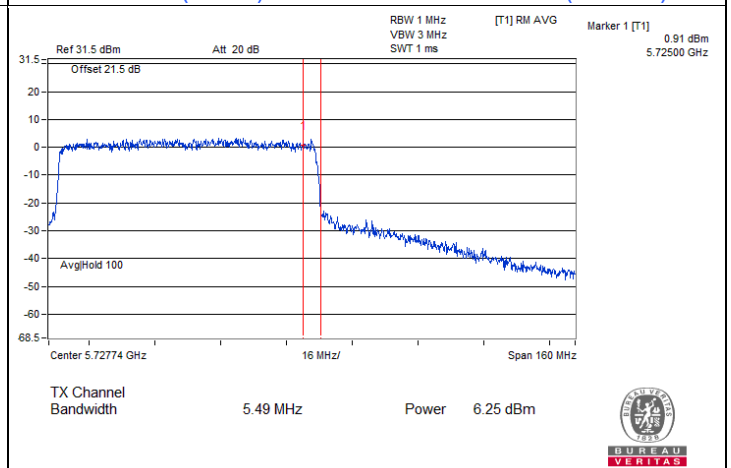

802.11ax (HE80) CDD / Chain 1 : CH 138 (U-NII-3)

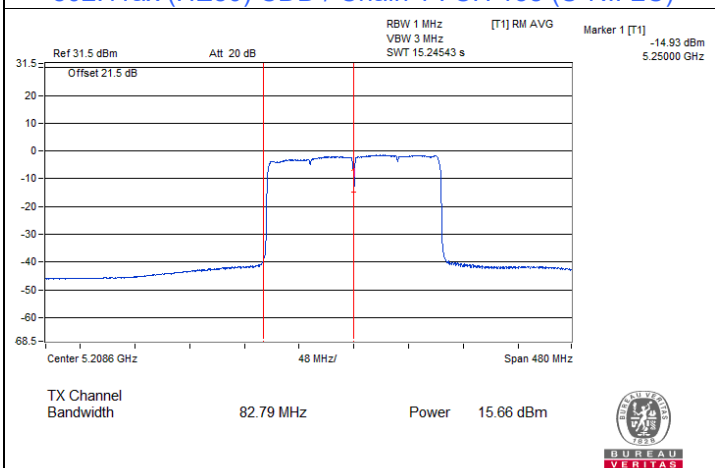

802.11ax (HE160) CDD / Chain 0 : CH 50 (U-NII-1)

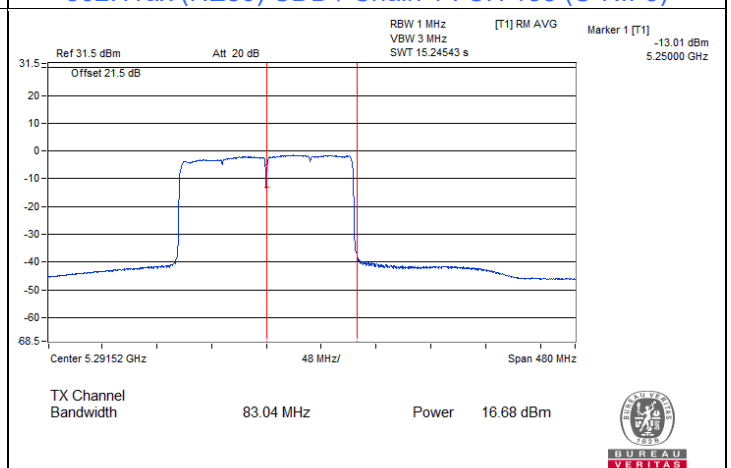

802.11ax (HE160) CDD / Chain 0 : CH 50 (U-NII-2A)



Spectrum Plot for channel straddling

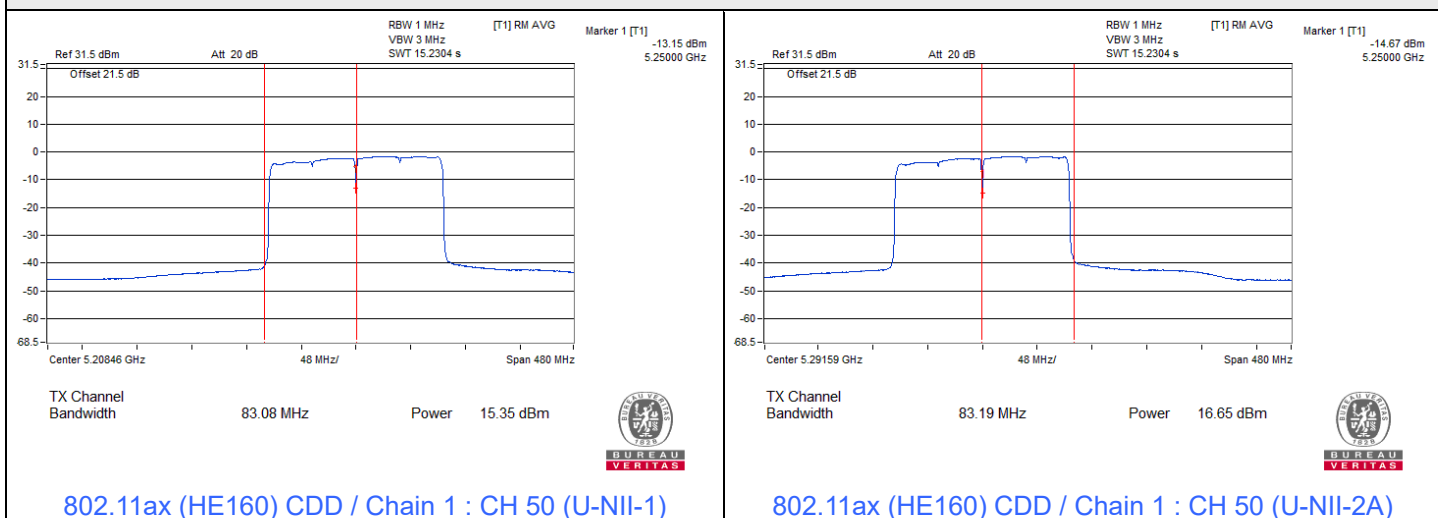

7.3 Power Spectral Density

Input Power:	120 Vac, 60 Hz	Environmental Conditions:	25°C, 60% RH	Tested By:	John Peng
--------------	----------------	---------------------------	--------------	------------	-----------

802.11a

Chan.	Chan. Freq. (MHz)	PSD (dBm/MHz)		Total PSD (dBm/MHz)	Max. PSD Limit (dBm/MHz)	Test Result
		Chain 0	Chain 1			
36	5180	9.18	9.14	12.17	17	Pass
40	5200	11.95	12.01	14.99	17	Pass
48	5240	9.88	10.34	13.13	17	Pass
52	5260	6.99	6.51	9.77	11	Pass
60	5300	7.13	6.66	9.91	11	Pass
64	5320	7.20	6.68	9.96	11	Pass
100	5500	7.52	5.19	9.52	11	Pass
116	5580	7.19	7.03	10.12	11	Pass
140	5700	6.66	5.76	9.24	11	Pass
144 (U-NII-2C)	5720	8.39	7.39	10.93	11	Pass

Notes:

- Method E) 2) a) of power density measurement of KDB 662911 is using for calculating total power density. Total power density is summing entire spectra across corresponding frequency bins on the various outputs by computer.
- Directional gain = $10 \log[(10^{\text{Chain0}/20} + 10^{\text{Chain1}/20})^2 / 2]$
- For U-NII-1, the directional gain is 5.45 dBi < 6dBi, so the power density limit shall not be reduced.
- For U-NII-2A, the directional gain is 5.45 dBi < 6 dBi, so the power density limit shall not be reduced.
- For U-NII-2C, the directional gain is 5.74 dBi < 6dBi, so the power density limit shall not be reduced.

802.11ax (HE20)

Chan.	Chan. Freq. (MHz)	PSD (dBm/MHz)		Total PSD (dBm/MHz)	Max. PSD Limit (dBm/MHz)	Test Result
		Chain 0	Chain 1			
36	5180	8.92	8.38	11.67	17	Pass
40	5200	6.17	11.10	12.31	17	Pass
48	5240	9.31	9.94	12.65	17	Pass
52	5260	6.87	5.64	9.31	11	Pass
60	5300	7.08	5.80	9.50	11	Pass
64	5320	7.06	5.99	9.57	11	Pass
100	5500	6.89	6.46	9.69	11	Pass
116	5580	6.69	6.88	9.80	11	Pass
140	5700	6.17	4.98	8.63	11	Pass
144 (U-NII-2C)	5720	7.91	6.87	10.43	11	Pass

Notes:

- Method E) 2) a) of power density measurement of KDB 662911 is using for calculating total power density. Total power density is summing entire spectra across corresponding frequency bins on the various outputs by computer.
- Directional gain = $10 \log[(10^{\text{Chain0}/20} + 10^{\text{Chain1}/20})^2 / 2]$
- For U-NII-1, the directional gain is 5.45 dBi < 6dBi, so the power density limit shall not be reduced.
- For U-NII-2A, the directional gain is 5.45 dBi < 6 dBi, so the power density limit shall not be reduced.
- For U-NII-2C, the directional gain is 5.74 dBi < 6 dBi, so the power density limit shall not be reduced.

802.11ax (HE40)

Chan.	Chan. Freq. (MHz)	PSD (dBm/MHz)		Total PSD (dBm/MHz)	Max. PSD Limit (dBm/MHz)	Test Result
		Chain 0	Chain 1			
38	5190	3.76	2.62	6.24	17	Pass
46	5230	8.31	7.70	11.03	17	Pass
54	5270	5.22	4.38	7.83	11	Pass
62	5310	2.99	2.06	5.56	11	Pass
102	5510	4.80	3.90	7.38	11	Pass
110	5550	4.89	4.15	7.55	11	Pass
134	5670	5.16	3.73	7.51	11	Pass
142 (U-NII-2C)	5710	5.05	3.49	7.35	11	Pass

Notes:

- Method E) 2) a) of power density measurement of KDB 662911 is using for calculating total power density. Total power density is summing entire spectra across corresponding frequency bins on the various outputs by computer.
- Directional gain = $10 \log[(10^{\text{Chain0}/20} + 10^{\text{Chain1}/20})^2 / 2]$
- For U-NII-1, the directional gain is 5.45 dBi < 6dBi, so the power density limit shall not be reduced.
- For U-NII-2A, the directional gain is 5.45 dBi < 6 dBi, so the power density limit shall not be reduced.
- For U-NII-2C, the directional gain is 5.74 dBi < 6 dBi, so the power density limit shall not be reduced.

802.11ax (HE80)

Chan.	Chan. Freq. (MHz)	PSD (dBm/MHz)		Total PSD (dBm/MHz)	Max. PSD Limit (dBm/MHz)	Test Result
		Chain 0	Chain 1			
42	5210	0.06	-2.44	2.00	17	Pass
58	5290	-0.12	-1.03	2.46	11	Pass
106	5530	1.03	0.40	3.74	11	Pass
122	5610	-0.55	1.89	3.85	11	Pass
138 (U-NII-2C)	5690	2.03	1.96	5.01	11	Pass

Notes:

- Method E) 2) a) of power density measurement of KDB 662911 is using for calculating total power density. Total power density is summing entire spectra across corresponding frequency bins on the various outputs by computer.
- Directional gain = $10 \log[(10^{\text{Chain0}/20} + 10^{\text{Chain1}/20})^2 / 2]$
- For U-NII-1, the directional gain is 5.45 dBi < 6dBi, so the power density limit shall not be reduced.
- For U-NII-2A, the directional gain is 5.45 dBi < 6 dBi, so the power density limit shall not be reduced.
- For U-NII-2C, the directional gain is 5.74 dBi < 6 dBi, so the power density limit shall not be reduced.

802.11ax (HE160)

Chan.	Chan. Freq. (MHz)	PSD (dBm/MHz)		Total PSD (dBm/MHz)	Max. PSD Limit (dBm/MHz)	Test Result
		Chain 0	Chain 1			
50 (U-NII-1)	5250	-4.60	-5.54	-2.03	17	Pass
50 (U-NII-2A)	5250	-3.90	-4.73	-1.28	11	Pass
114	5570	-2.74	-3.70	-0.18	11	Pass

Notes:

- Method E) 2) a) of power density measurement of KDB 662911 is using for calculating total power density. Total power density is summing entire spectra across corresponding frequency bins on the various outputs by computer.
- Directional gain = $10 \log[(10^{\text{Chain0}/20} + 10^{\text{Chain1}/20})^2 / 2]$
- For U-NII-1, the directional gain is 5.45 dBi < 6dBi, so the power density limit shall not be reduced.
- For U-NII-2A, the directional gain is 5.45 dBi < 6 dBi, so the power density limit shall not be reduced.
- For U-NII-2C, the directional gain is 5.74 dBi < 6 dBi, so the power density limit shall not be reduced.

802.11a

Chan.	Chan. Freq. (MHz)	PSD (dBm/300kHz)		Total PSD (dBm/300kHz)	Total PSD (dBm/500kHz)	PSD Limit (dBm/500kHz)	Test Result
		Chain 0	Chain 1				
144 (U-NII-3)	5720	3.17	2.13	5.69	7.91	30	Pass
149	5745	4.71	6.06	8.45	10.67	30	Pass
157	5785	8.69	7.87	11.31	13.53	30	Pass
165	5825	6.54	8.93	10.91	13.13	30	Pass

Notes:

1. Method E) 2) b) Measure and sum spectral maxima across the outputs of KDB 662911 is using for calculating total power density.
2. Directional gain = $10 \log[(10^{\text{Chain0}/20} + 10^{\text{Chain1}/20})^2 / 2]$
3. For U-NII-3, the directional gain is 5.63 dBi < 6 dBi, so the power density limit shall not be reduced.

802.11ax (HE20)

Chan.	Chan. Freq. (MHz)	PSD (dBm/300kHz)		Total PSD (dBm/300kHz)	Total PSD (dBm/500kHz)	PSD Limit (dBm/500kHz)	Test Result
		Chain 0	Chain 1				
144 (U-NII-3)	5720	2.41	1.42	4.95	7.17	30	Pass
149	5745	7.93	7.40	10.68	12.90	30	Pass
157	5785	8.21	7.40	10.83	13.05	30	Pass
165	5825	7.99	8.26	11.14	13.36	30	Pass

Notes:

1. Method E) 2) b) Measure and sum spectral maxima across the outputs of KDB 662911 is using for calculating total power density.
2. Directional gain = $10 \log[(10^{\text{Chain0}/20} + 10^{\text{Chain1}/20})^2 / 2]$
3. For U-NII-3, the directional gain is 5.63 dBi < 6 dBi, so the power density limit shall not be reduced.

802.11ax (HE40)

Chan.	Chan. Freq. (MHz)	PSD (dBm/300kHz)		Total PSD (dBm/300kHz)	Total PSD (dBm/500kHz)	PSD Limit (dBm/500kHz)	Test Result
		Chain 0	Chain 1				
142 (U-NII-3)	5710	-0.67	-2.33	1.59	3.81	30	Pass
151	5755	3.16	2.50	5.85	8.07	30	Pass
159	5795	4.04	2.93	6.53	8.75	30	Pass

Notes:

1. Method E) 2) b) Measure and sum spectral maxima across the outputs of KDB 662911 is using for calculating total power density.
2. Directional gain = $10 \log[(10^{\text{Chain0}/20} + 10^{\text{Chain1}/20})^2 / 2]$
3. For U-NII-3, the directional gain is 5.63 dBi < 6 dBi, so the power density limit shall not be reduced.



802.11ax (HE80)

Chan.	Chan. Freq. (MHz)	PSD (dBm/300kHz)		Total PSD (dBm/300kHz)	Total PSD (dBm/500kHz)	PSD Limit (dBm/500kHz)	Test Result
		Chain 0	Chain 1				
138 (U-NII-3)	5690	-4.25	-4.45	-1.34	0.88	30	Pass
155	5775	-2.27	-3.04	0.37	2.59	30	Pass

Notes:

1. Method E) 2) b) Measure and sum spectral maxima across the outputs of KDB 662911 is using for calculating total power density.
2. Directional gain = $10 \log[(10^{\text{Chain0}/20} + 10^{\text{Chain1}/20})^2 / 2]$
3. For U-NII-3, the directional gain is 5.63 dBi < 6 dBi, so the power density limit shall not be reduced.

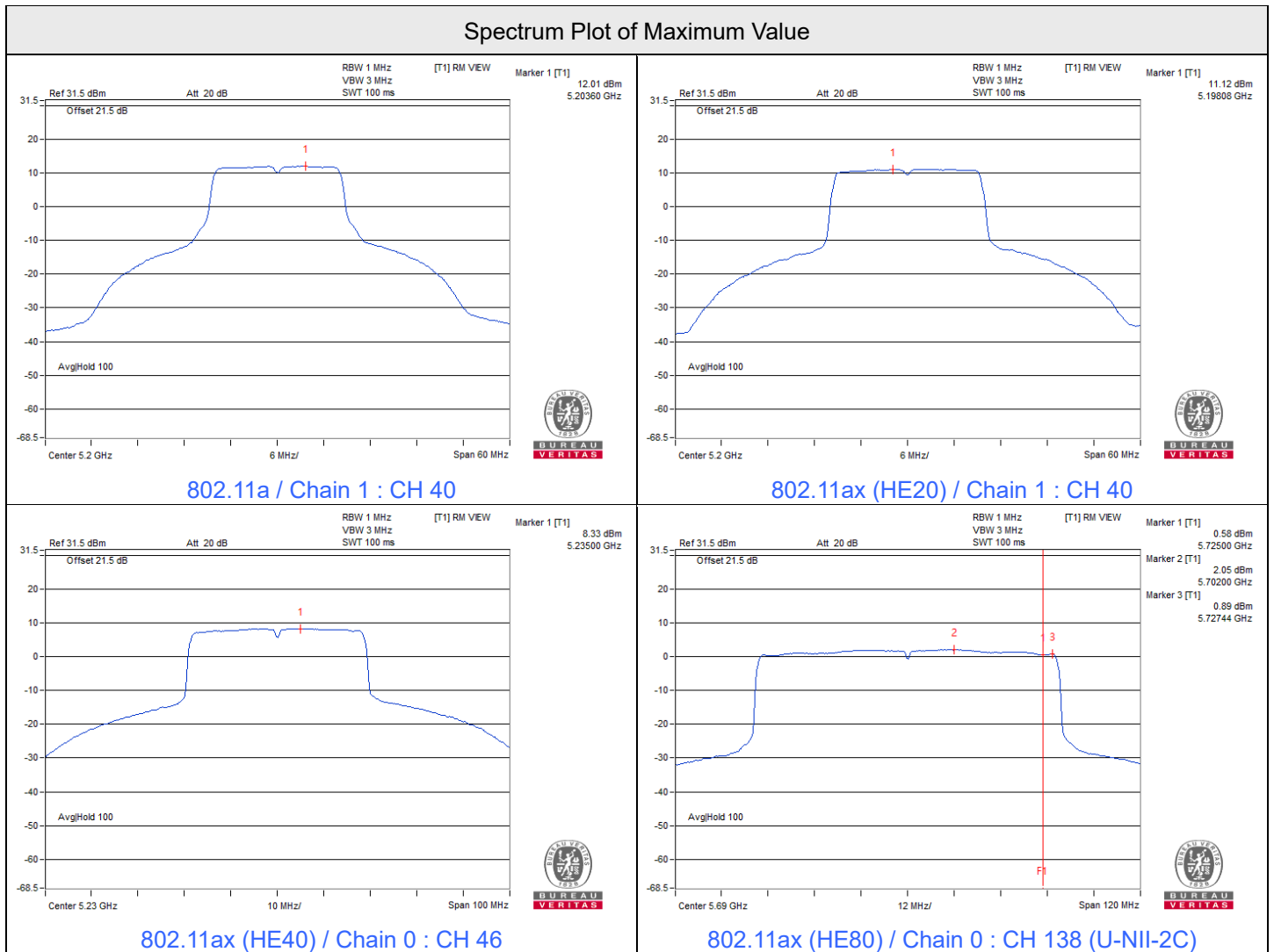

Spectrum Plot of Maximum Value

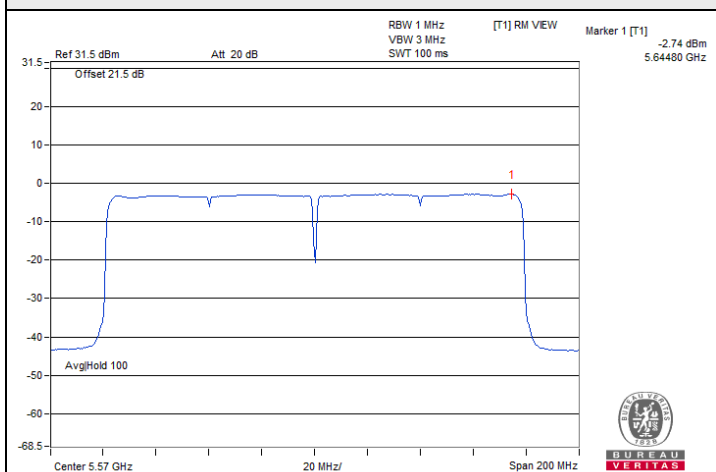

802.11ax (HE160) / Chain 0 : CH 114

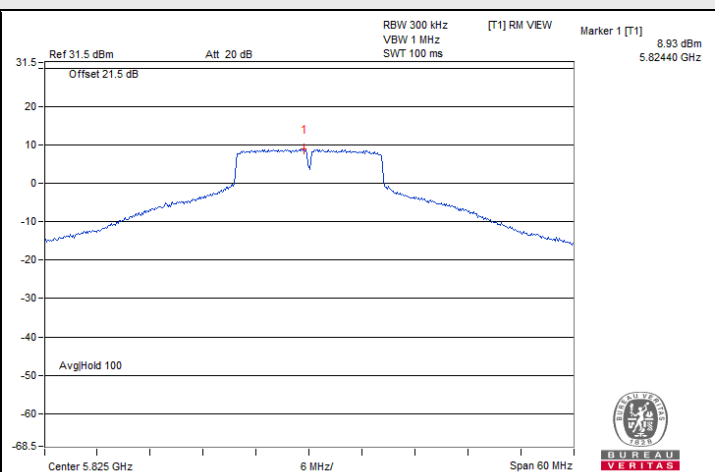

802.11a / Chain 1 : CH 165

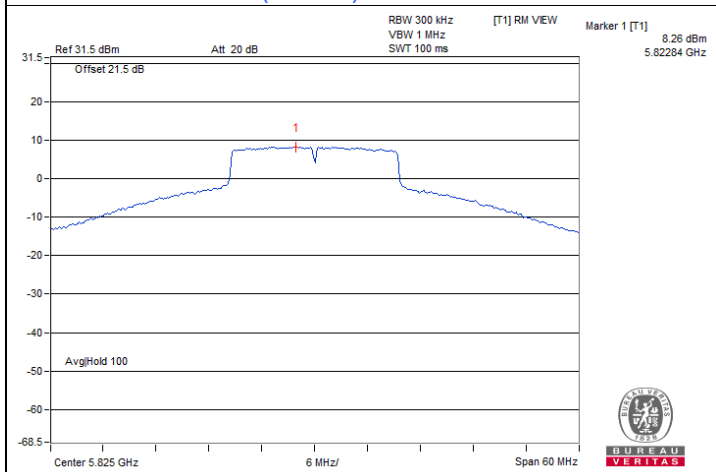

802.11ax (HE20) / Chain 1 : CH 165

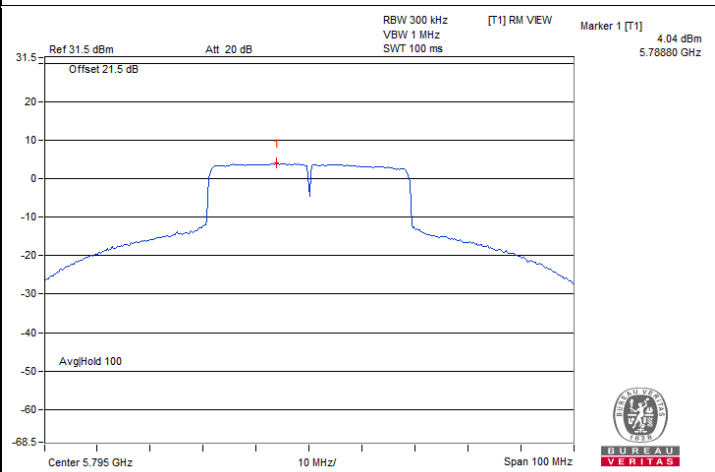

802.11ax (HE40) / Chain 0 : CH 159

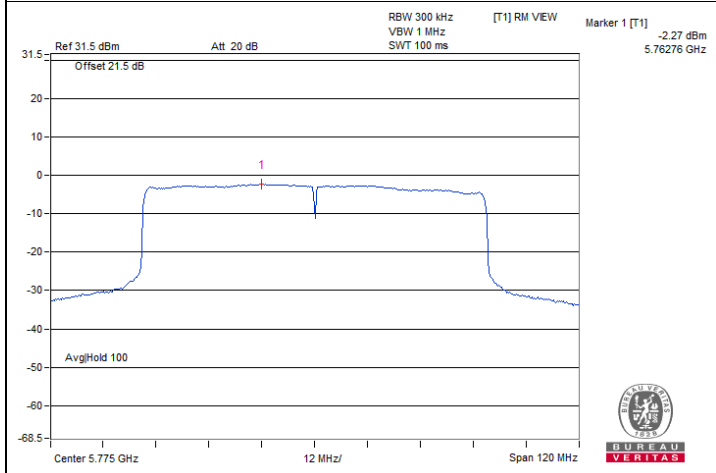

802.11ax (HE80) / Chain 0 : CH 155

7.4 6 dB Bandwidth

Input Power:	120 Vac, 60 Hz	Environmental Conditions:	25°C, 60% RH	Tested By:	John Peng
--------------	----------------	---------------------------	--------------	------------	-----------

802.11a

Channel	Frequency (MHz)	6 dB Bandwidth (MHz)		Minimum Limit (MHz)	Test Result
		Chain 0	Chain 1		
144 (U-NII-3)	5720	3.13	3.15	0.5	Pass
149	5745	16.38	16.28	0.5	Pass
157	5785	16.33	16.33	0.5	Pass
165	5825	16.30	16.34	0.5	Pass

802.11ax (HE20)

Channel	Frequency (MHz)	6 dB Bandwidth (MHz)		Minimum Limit (MHz)	Test Result
		Chain 0	Chain 1		
144 (U-NII-3)	5720	4.46	4.10	0.5	Pass
149	5745	18.51	17.63	0.5	Pass
157	5785	16.71	18.48	0.5	Pass
165	5825	18.59	18.83	0.5	Pass

802.11ax (HE40)

Channel	Frequency (MHz)	6 dB Bandwidth (MHz)		Minimum Limit (MHz)	Test Result
		Chain 0	Chain 1		
142 (U-NII-3)	5710	3.44	3.52	0.5	Pass
151	5755	37.09	36.51	0.5	Pass
159	5795	37.23	37.26	0.5	Pass

802.11ax (HE80)

Channel	Frequency (MHz)	6 dB Bandwidth (MHz)		Minimum Limit (MHz)	Test Result
		Chain 0	Chain 1		
138 (U-NII-3)	5690	2.74	3.70	0.5	Pass
155	5775	76.46	76.19	0.5	Pass

Spectrum Plot of Minimum Value

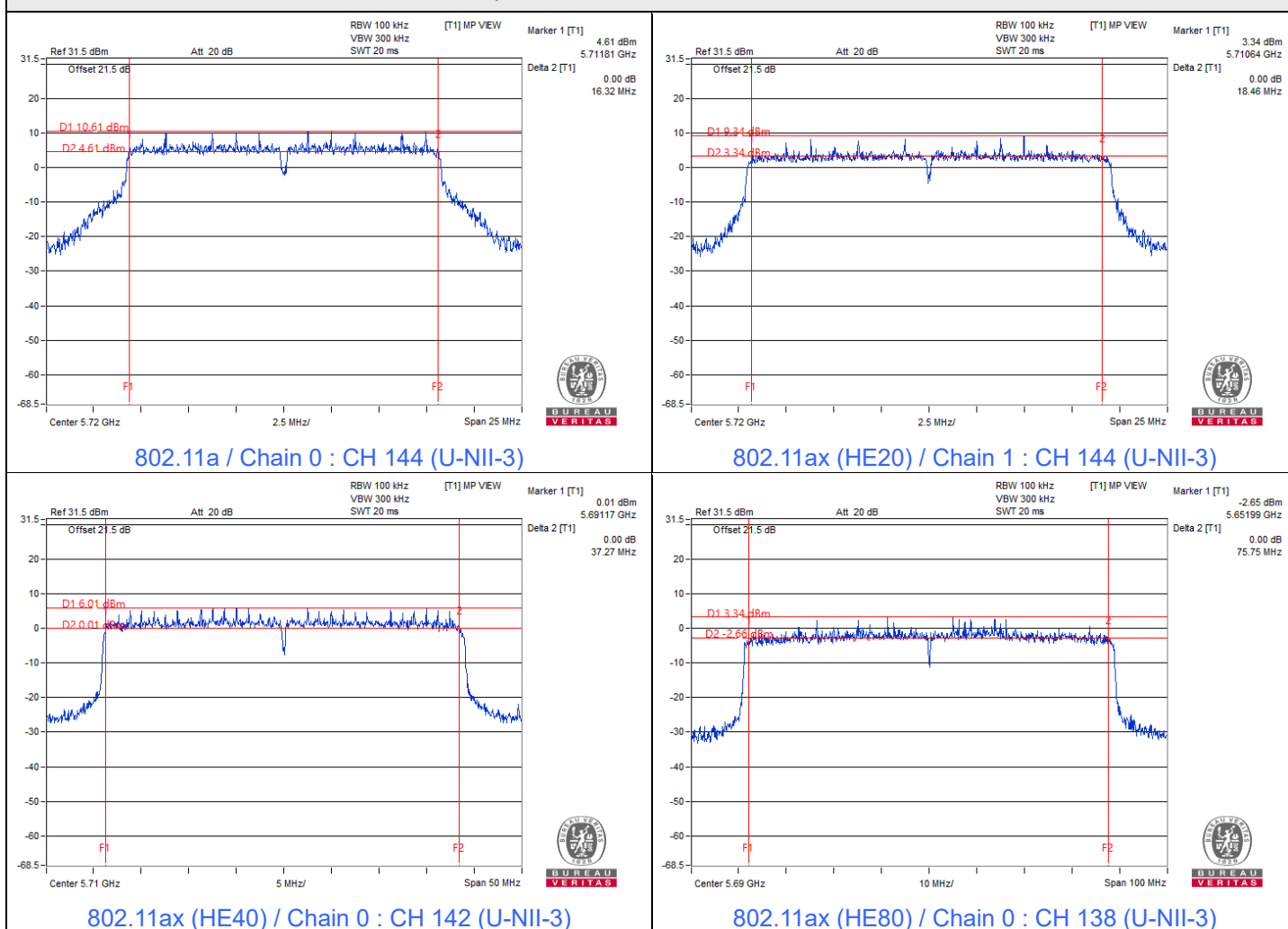
**Notes:**

1. For U-NII-3 straddle channel = Marker 1 + Delta 2 - 5725 MHz

7.5 Occupied Bandwidth

Input Power:	120 Vac, 60 Hz	Environmental Conditions:	25°C, 60% RH	Tested By:	John Peng
--------------	----------------	---------------------------	--------------	------------	-----------

802.11a

Channel	Frequency (MHz)	Occupied Bandwidth (MHz)	
		Chain 0	Chain 1
36	5180	16.92	16.98
40	5200	19.80	18.54
48	5240	17.22	17.34
52	5260	17.04	16.98
60	5300	16.98	16.92
64	5320	16.98	16.98
100	5500	16.92	16.98
116	5580	16.74	16.92
140	5700	16.80	16.80
144 (U-NII-2C)	5720	13.40	13.46
144 (U-NII-3)	5720	3.46	3.40
149	5745	28.56	17.10
157	5785	22.74	27.12
165	5825	19.50	25.86

802.11ax (HE20)

Channel	Frequency (MHz)	Occupied Bandwidth (MHz)	
		Chain 0	Chain 1
36	5180	19.14	19.14
40	5200	19.56	19.20
48	5240	19.26	19.08
52	5260	19.02	19.08
60	5300	19.08	19.08
64	5320	19.14	19.08
100	5500	19.08	19.14
116	5580	19.20	19.08
140	5700	19.02	19.02
144 (U-NII-2C)	5720	14.54	14.54
144 (U-NII-3)	5720	4.54	4.54
149	5745	26.04	20.16
157	5785	28.02	19.68
165	5825	19.38	27.66

802.11ax (HE40)

Channel	Frequency (MHz)	Occupied Bandwidth (MHz)	
		Chain 0	Chain 1
38	5190	37.80	38.04
46	5230	38.52	38.04
54	5270	37.80	37.80
62	5310	37.92	37.92
102	5510	37.92	37.80
110	5550	38.16	37.80
134	5670	37.80	37.92
142 (U-NII-2C)	5710	33.84	33.96
142 (U-NII-3)	5710	3.96	3.96
151	5755	38.52	38.04
159	5795	38.88	38.64

802.11ax (HE80)

Channel	Frequency (MHz)	Occupied Bandwidth (MHz)	
		Chain 0	Chain 1
42	5210	77.04	77.28
58	5290	77.04	77.04
106	5530	77.28	77.28
122	5610	77.28	77.04
138 (U-NII-2C)	5690	73.40	73.40
138 (U-NII-3)	5690	3.64	3.40
155	5775	77.28	77.04

802.11ax (HE160)

Channel	Frequency (MHz)	Occupied Bandwidth (MHz)	
		Chain 0	Chain 1
50 (U-NII-1)	5250	78.24	77.28
50 (U-NII-2A)	5250	77.76	78.24
114	5570	156.00	156.00

Spectrum Plot of Maximum Value

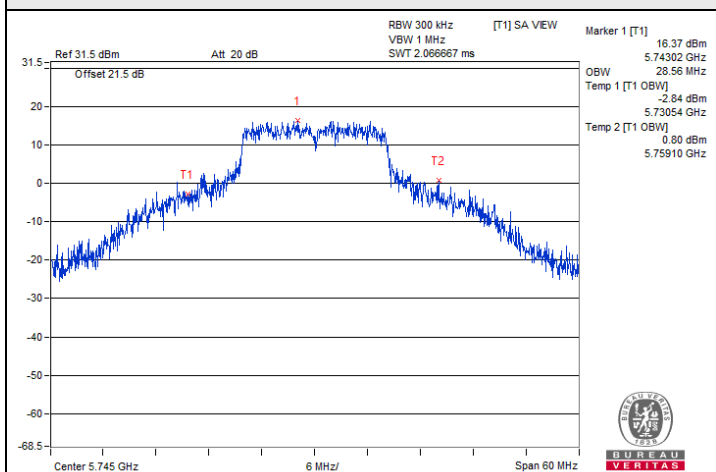

802.11a / Chain 0 : CH 149

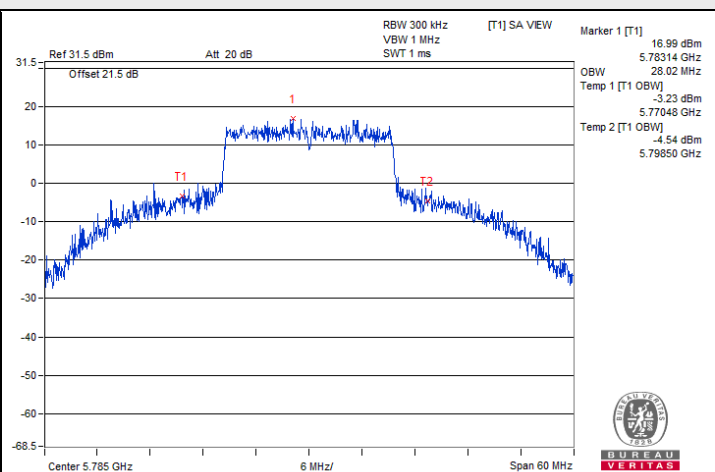

802.11ax (HE20) / Chain 0 : CH 157

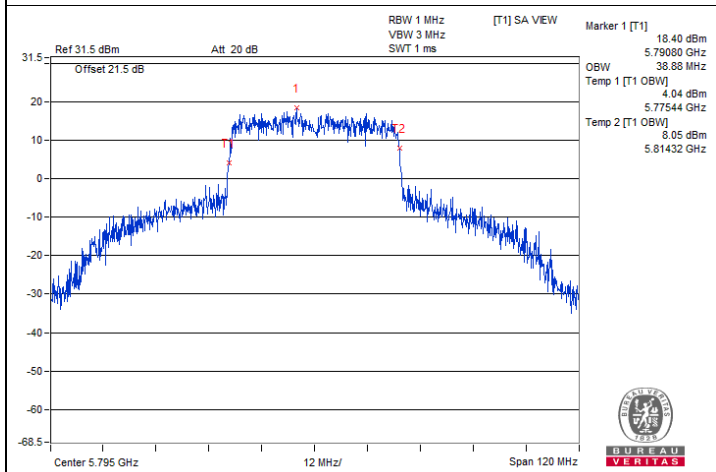

802.11ax (HE40) / Chain 0 : CH 159

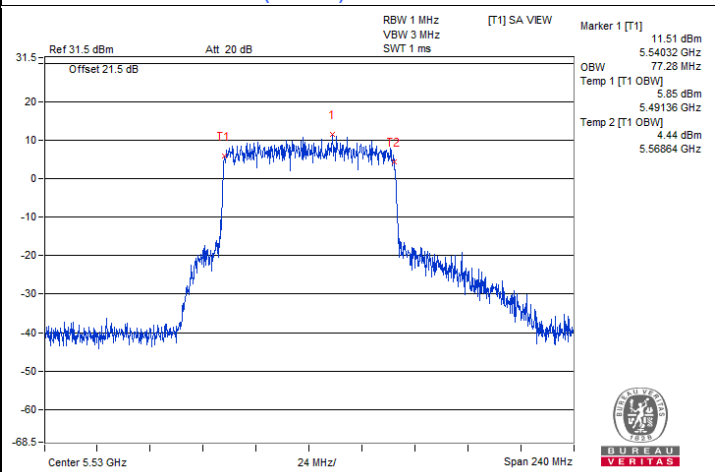

802.11ax (HE80) / Chain 0 : CH 106

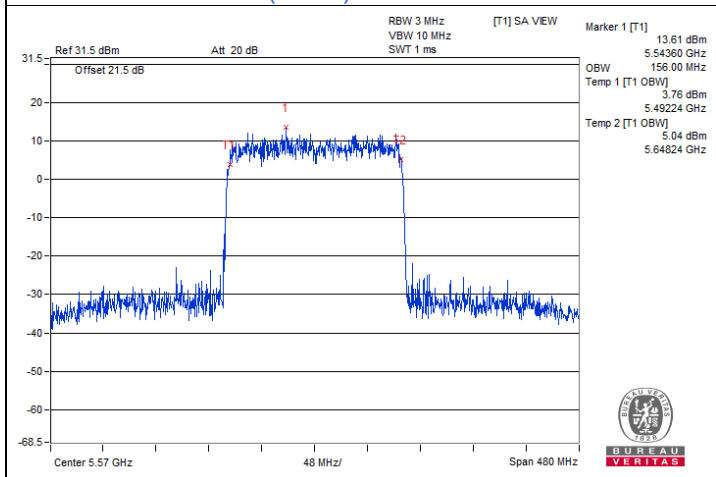

802.11ax (HE160) / Chain 0 : CH 114

Spectrum Plot for nearby DFS band (DFS is required, if 99% OCP straddle into U-NII-2A)

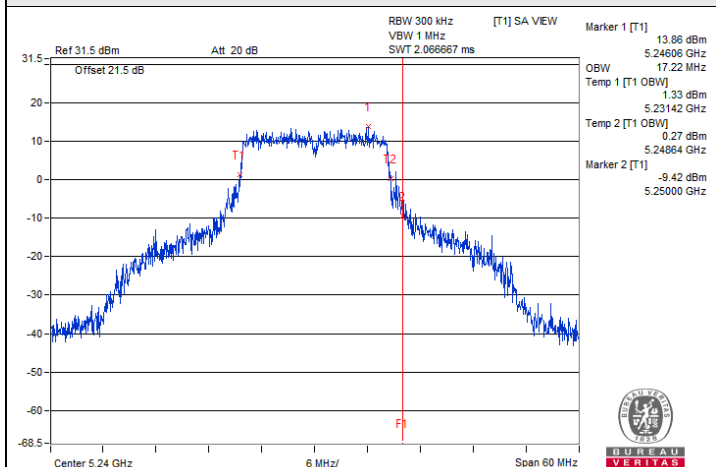
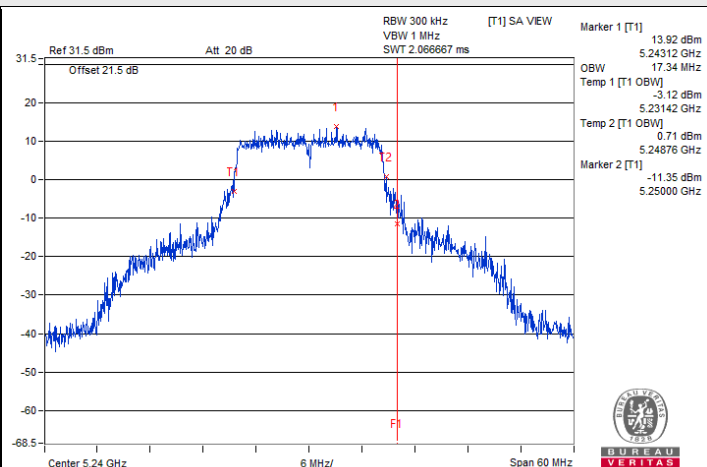
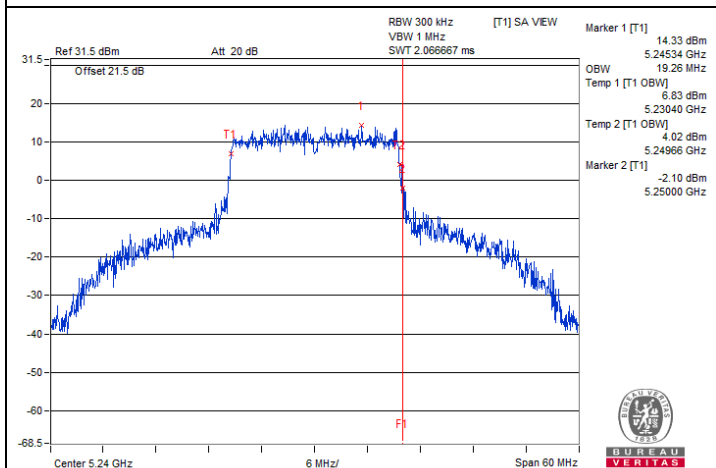
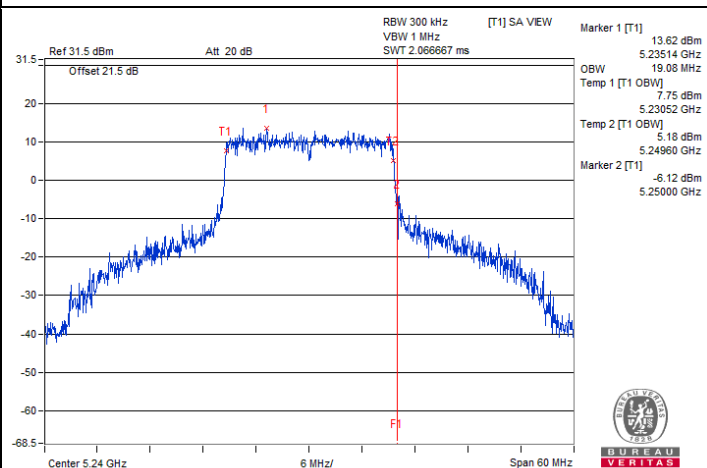
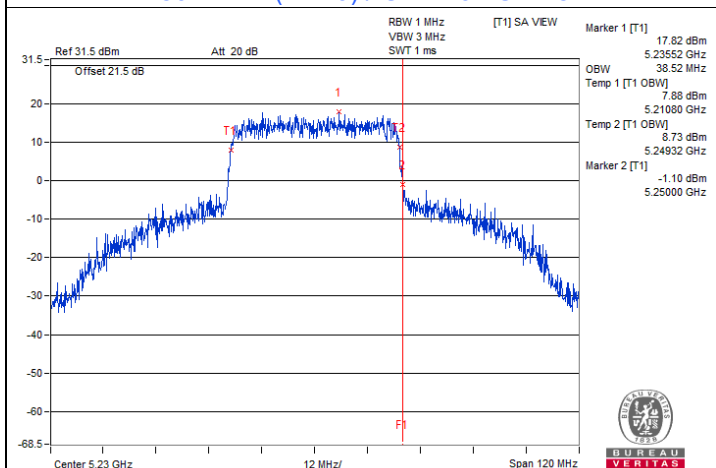
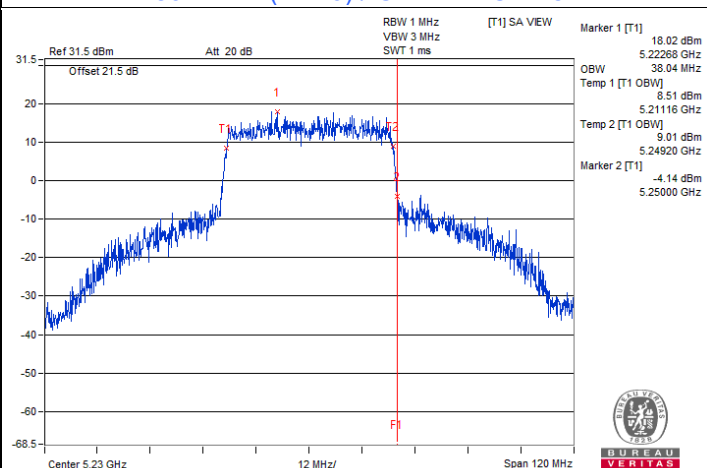
**802.11a / Chain 0 : CH 48****802.11a / Chain 1 : CH 48****802.11ax (HE20) / Chain 0 : CH 48****802.11ax (HE20) / Chain 1 : CH 48****802.11ax (HE40) / Chain 0 : CH 46****802.11ax (HE40) / Chain 1 : CH 46**

Spectrum Plot for nearby DFS band (DFS is required, if 99% OCP straddle into U-NII-2A)

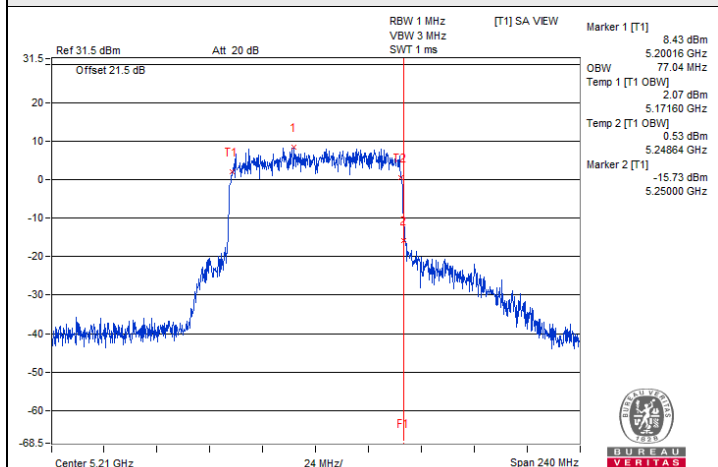

802.11ax (HE80) / Chain 0 : CH 42

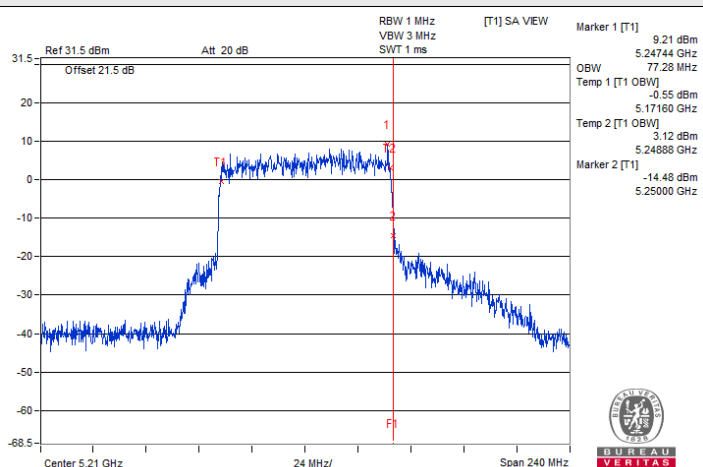

802.11ax (HE80) / Chain 1 : CH 42

Spectrum Plot for nearby DFS band (DFS is required, if 99% OCP straddle into U-NII-2C)

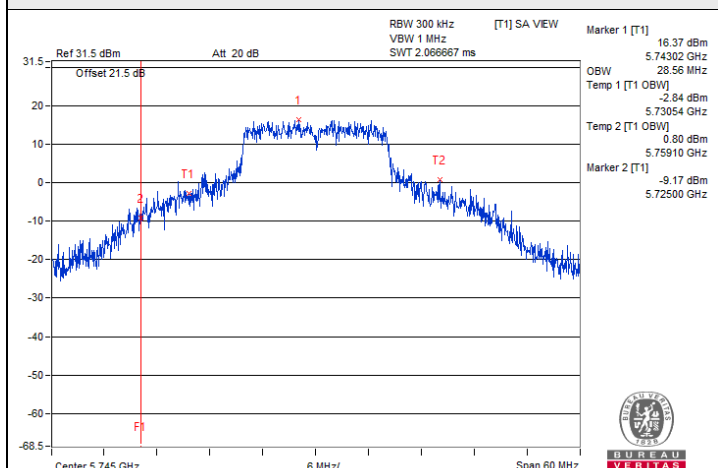

802.11a / Chain 0 : CH 149

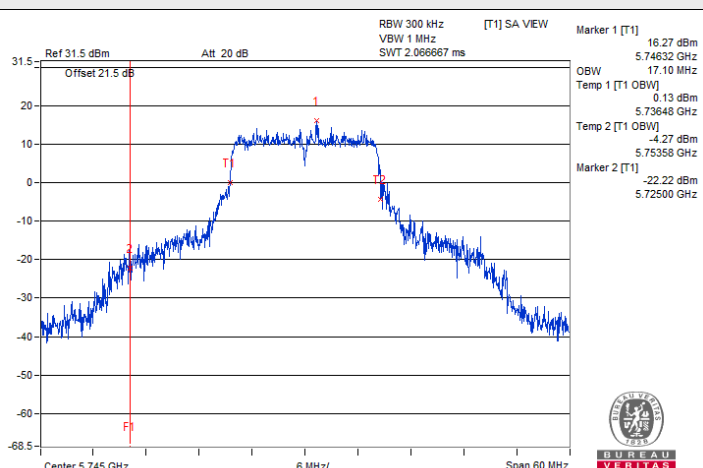

802.11a / Chain 1 : CH 149

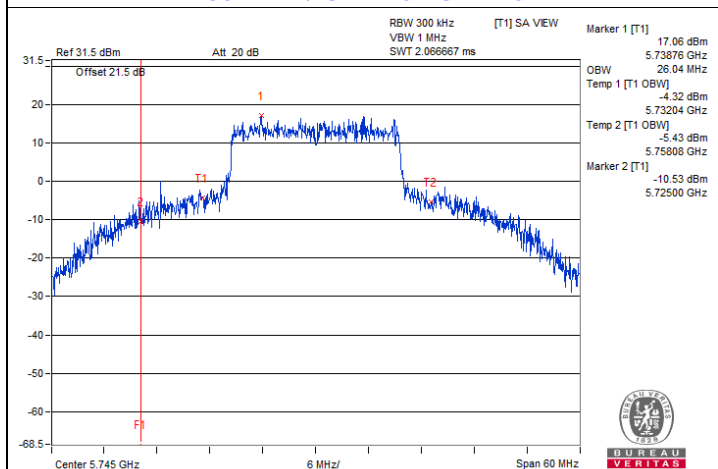

802.11ax (HE20) / Chain 0 : CH 149

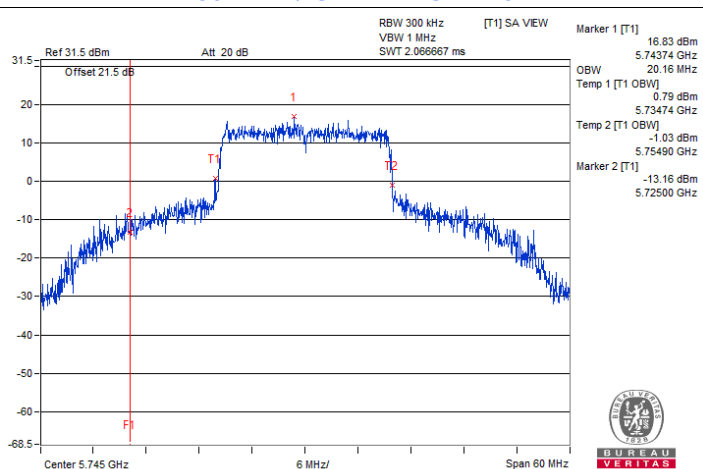

802.11ax (HE20) / Chain 1 : CH 149



Spectrum Plot for nearby DFS band (DFS is required, if 99% OCP straddle into U-NII-2C)

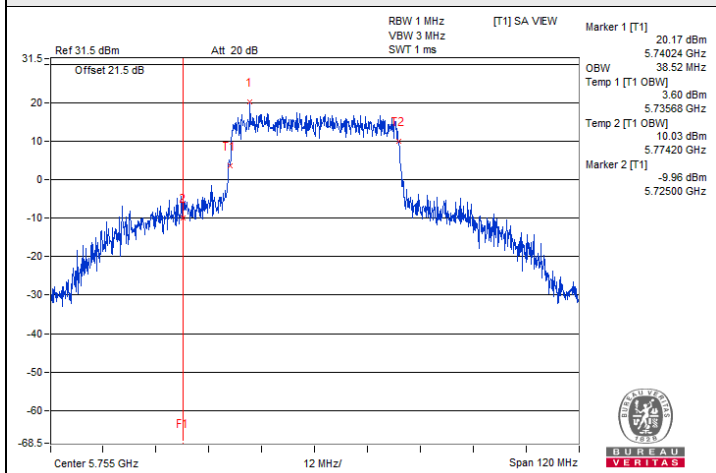

802.11ax (HE40) / Chain 0 : CH 151

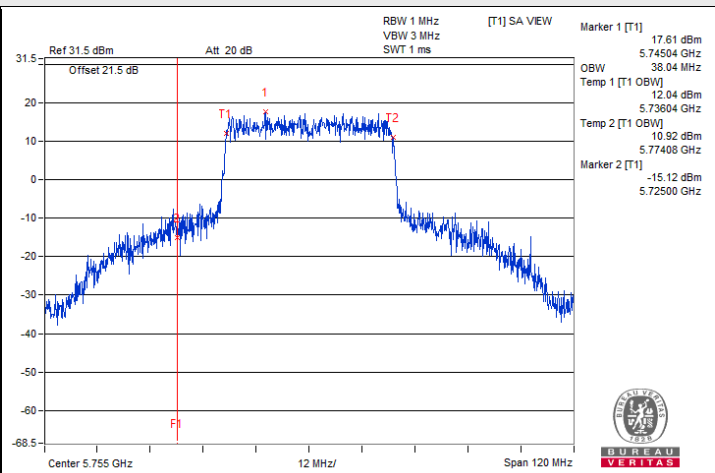

802.11ax (HE40) / Chain 1 : CH 151

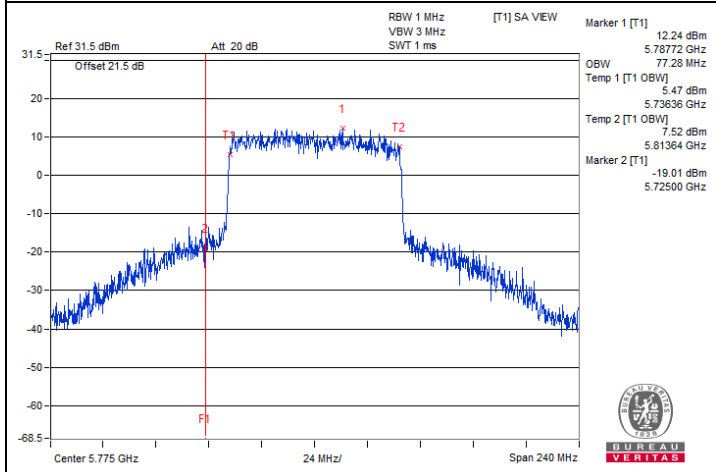

802.11ax (HE80) / Chain 0 : CH 155

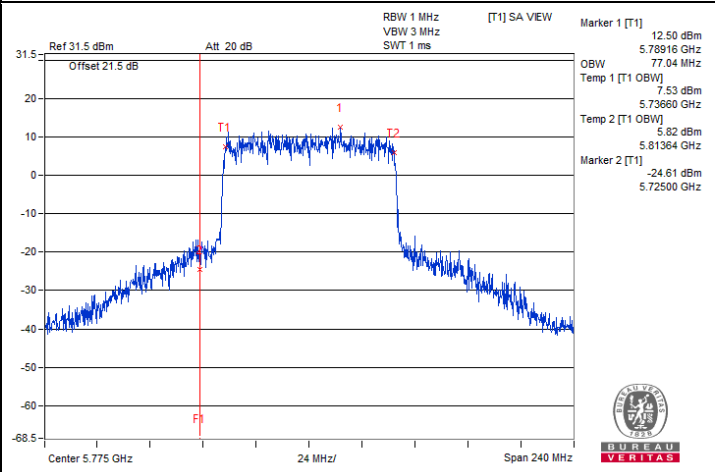

802.11ax (HE80) / Chain 1 : CH 155

7.6 Frequency Stability

Input Power:	120 Vac, 60 Hz	Environmental Conditions:	25°C, 60% RH	Tested By:	John Peng
--------------	----------------	---------------------------	--------------	------------	-----------

802.11a

Frequency Stability Versus Temperature									
Operating Frequency: 5180 MHz									
Temp. (°C)	Power Supply (Vac)	0 Minute		2 Minutes		5 Minutes		10 Minutes	
		Measured Frequency (MHz)	Test Result	Measured Frequency (MHz)	Test Result	Measured Frequency (MHz)	Test Result	Measured Frequency (MHz)	Test Result
40	120	5179.9809	Pass	5179.9849	Pass	5179.9818	Pass	5179.9808	Pass
30	120	5179.9824	Pass	5179.9834	Pass	5179.9817	Pass	5179.9816	Pass
20	120	5179.9781	Pass	5179.9756	Pass	5179.9789	Pass	5179.975	Pass
10	120	5179.9958	Pass	5179.9976	Pass	5179.9962	Pass	5179.998	Pass
0	120	5179.9761	Pass	5179.9758	Pass	5179.9752	Pass	5179.9729	Pass

Frequency Stability Versus Voltage									
Operating Frequency: 5180 MHz									
Temp. (°C)	Power Supply (Vac)	0 Minute		2 Minutes		5 Minutes		10 Minutes	
		Measured Frequency (MHz)	Test Result	Measured Frequency (MHz)	Test Result	Measured Frequency (MHz)	Test Result	Measured Frequency (MHz)	Test Result
20	138	5180.0043	Pass	5180.0052	Pass	5180.0052	Pass	5180.0051	Pass
	120	5179.9958	Pass	5179.9976	Pass	5179.9962	Pass	5179.998	Pass
	102	5180.0011	Pass	5180.0004	Pass	5180.0011	Pass	5179.9989	Pass

7.7 AC Power Conducted Emissions

RF Mode	802.11ax (HE20)	Channel	CH 157 : 5785 MHz
Frequency Range	150kHz ~ 30MHz	Detector Function & Resolution Bandwidth	Quasi-Peak (QP) / Average (AV), 9 kHz
Input Power	120 Vac, 60 Hz	Environmental Conditions	25°C, 75% RH
Tested By	Carter Lin		

Phase Of Power : Line (L)										
No	Frequency (MHz)	Correction Factor (dB)	Reading Value (dBuV)		Emission Level (dBuV)		Limit (dBuV)		Margin (dB)	
			Q.P.	AV.	Q.P.	AV.	Q.P.	AV.	Q.P.	AV.
1	0.16175	9.96	37.12	21.42	47.08	31.38	65.37	55.37	-18.29	-23.99
2	0.35062	9.97	32.55	32.39	42.52	42.36	58.95	48.95	-16.43	-6.59
3	0.56793	9.98	14.34	7.77	24.32	17.75	56.00	46.00	-31.68	-28.25
4	1.07426	10.00	14.41	10.86	24.41	20.86	56.00	46.00	-31.59	-25.14
5	2.06649	10.05	14.75	7.17	24.80	17.22	56.00	46.00	-31.20	-28.78
6	26.74601	11.21	20.25	18.08	31.46	29.29	60.00	50.00	-28.54	-20.71

Remarks:

1. Q.P. and AV. are abbreviations of quasi-peak and average individually.
2. The emission levels of other frequencies were very low against the limit.
3. Margin value = Emission level – Limit value
4. Correction factor = Insertion loss + Cable loss
5. Emission Level = Correction Factor + Reading Value

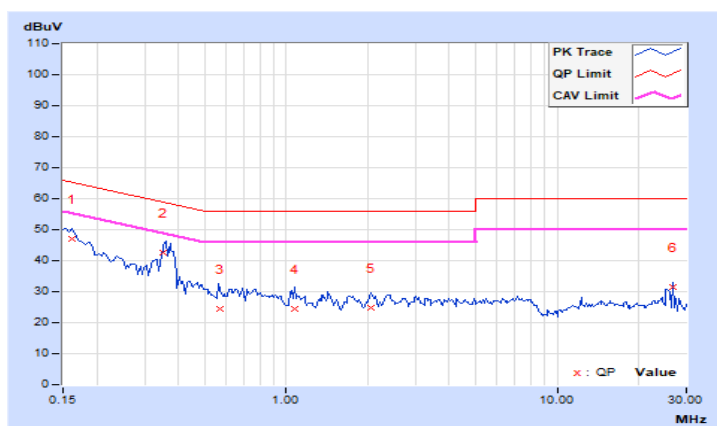

RF Mode	802.11ax (HE20)	Channel	CH 157 : 5785 MHz
Frequency Range	150kHz ~ 30MHz	Detector Function & Resolution Bandwidth	Quasi-Peak (QP) / Average (AV), 9 kHz
Input Power	120 Vac, 60 Hz	Environmental Conditions	25°C, 75% RH
Tested By	Carter Lin		

Phase Of Power : Neutral (N)										
No	Frequency (MHz)	Correction Factor (dB)	Reading Value (dBuV)		Emission Level (dBuV)		Limit (dBuV)		Margin (dB)	
			Q.P.	AV.	Q.P.	AV.	Q.P.	AV.	Q.P.	AV.
1	0.15780	9.93	36.72	21.43	46.65	31.36	65.58	55.58	-18.93	-24.22
2	0.22815	9.94	24.31	11.24	34.25	21.18	62.52	52.52	-28.27	-31.34
3	0.34933	9.94	33.65	31.86	43.59	41.80	58.98	48.98	-15.39	-7.18
4	0.72816	9.96	16.75	14.54	26.71	24.50	56.00	46.00	-29.29	-21.50
5	0.98208	9.97	15.39	12.37	25.36	22.34	56.00	46.00	-30.64	-23.66
6	25.98042	10.86	15.25	11.12	26.11	21.98	60.00	50.00	-33.89	-28.02

Remarks:

1. Q.P. and AV. are abbreviations of quasi-peak and average individually.
2. The emission levels of other frequencies were very low against the limit.
3. Margin value = Emission level – Limit value
4. Correction factor = Insertion loss + Cable loss
5. Emission Level = Correction Factor + Reading Value

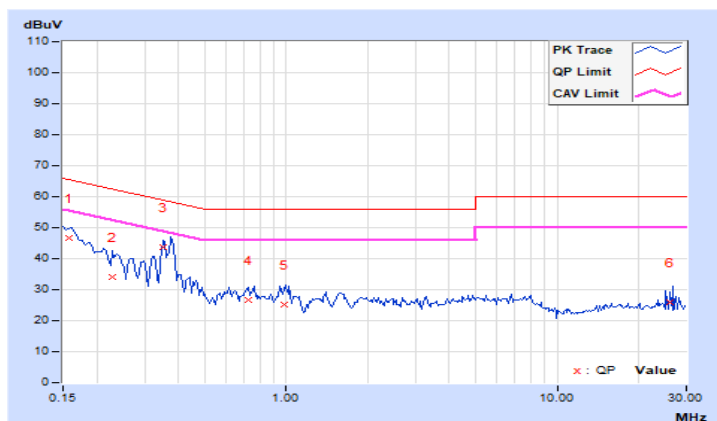

7.8 Unwanted Emissions below 1 GHz

RF Mode	802.11ax (HE20)	Channel	CH 157 : 5785 MHz
Frequency Range	30 MHz ~ 1 GHz	Detector Function & Bandwidth	(QP) RB = 120kHz
Input Power	120 Vac, 60 Hz	Environmental Conditions	20°C, 70% RH
Tested By	Ryan Du		

Antenna Polarity & Test Distance : Horizontal at 3 m								
No	Frequency (MHz)	Emission Level (dBuV/m)	Limit (dBuV/m)	Margin (dB)	Antenna Height (m)	Table Angle (Degree)	Raw Value (dBuV)	Correction Factor (dB/m)
1	63.20	31.4 QP	40.0	-8.6	1.50 H	236	44.4	-13.0
2	94.56	33.8 QP	43.5	-9.7	1.00 H	51	51.0	-17.2
3	173.53	31.8 QP	43.5	-11.7	1.50 H	248	44.1	-12.3
4	261.99	33.2 QP	46.0	-12.8	1.00 H	246	45.1	-11.9
5	463.03	38.8 QP	46.0	-7.2	2.00 H	347	44.2	-5.4
6	719.22	38.8 QP	46.0	-7.2	1.00 H	33	38.9	-0.1

Remarks:

1. Emission Level(dBuV/m) = Raw Value(dBuV) + Correction Factor(dB/m)
2. Correction Factor(dB/m) = Antenna Factor(dB/m) + Cable Factor(dB) – Pre-Amplifier Factor(dB)
3. Margin value = Emission Level – Limit value
4. The other emission levels were very low against the limit of frequency range 30 MHz ~ 1 GHz.
5. The emission levels were very low against the limit of frequency range 9 kHz ~ 30 MHz: the amplitude of spurious emissions attenuated more than 20 dB below the permissible value to be report.

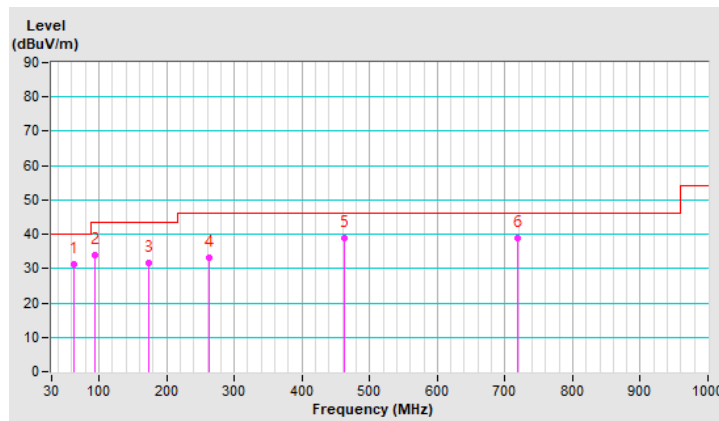

RF Mode	802.11ax (HE20)	Channel	CH 157 : 5785 MHz
Frequency Range	30 MHz ~ 1 GHz	Detector Function & Bandwidth	(QP) RB = 120kHz
Input Power	120 Vac, 60 Hz	Environmental Conditions	20°C, 70% RH
Tested By	Ryan Du		

Antenna Polarity & Test Distance : Vertical at 3 m								
No	Frequency (MHz)	Emission Level (dBuV/m)	Limit (dBuV/m)	Margin (dB)	Antenna Height (m)	Table Angle (Degree)	Raw Value (dBuV)	Correction Factor (dB/m)
1	46.53	32.5 QP	40.0	-7.5	1.00 V	37	44.6	-12.1
2	63.73	34.1 QP	40.0	-5.9	1.50 V	289	47.4	-13.3
3	108.70	35.7 QP	43.5	-7.8	1.00 V	151	50.4	-14.7
4	175.05	30.0 QP	43.5	-13.5	2.00 V	185	42.5	-12.5
5	466.65	39.9 QP	46.0	-6.1	1.00 V	347	45.3	-5.4
6	697.37	36.0 QP	46.0	-10.0	1.50 V	22	36.3	-0.3

Remarks:

1. Emission Level(dBuV/m) = Raw Value(dBuV) + Correction Factor(dB/m)
2. Correction Factor(dB/m) = Antenna Factor(dB/m) + Cable Factor(dB) – Pre-Amplifier Factor(dB)
3. Margin value = Emission Level – Limit value
4. The other emission levels were very low against the limit of frequency range 30 MHz ~ 1 GHz.
5. The emission levels were very low against the limit of frequency range 9 kHz ~ 30 MHz: the amplitude of spurious emissions attenuated more than 20 dB below the permissible value to be report.

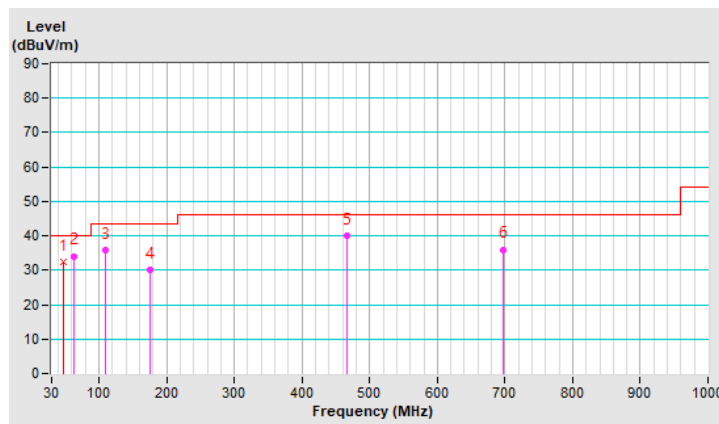

7.9 Unwanted Emissions above 1 GHz

RF Mode	802.11a	Channel	CH 36 : 5180 MHz
Frequency Range	1 GHz ~ 40 GHz	Detector Function & Bandwidth	(PK) RB = 1 MHz, VB = 3 MHz (AV) RB = 1 MHz, VB = 10 Hz
Input Power	120 Vac, 60 Hz	Environmental Conditions	20°C, 70% RH
Tested By	Ryan Du		

Antenna Polarity & Test Distance : Horizontal at 3 m								
No	Frequency (MHz)	Emission Level (dBuV/m)	Limit (dBuV/m)	Margin (dB)	Antenna Height (m)	Table Angle (Degree)	Raw Value (dBuV)	Correction Factor (dB/m)
1	5150.00	64.2 PK	74.0	-9.8	1.47 H	148	59.7	4.5
2	5150.00	52.2 AV	54.0	-1.8	1.47 H	148	47.7	4.5
3	*5180.00	117.2 PK			1.47 H	148	112.7	4.5
4	*5180.00	108.8 AV			1.47 H	148	104.3	4.5
5	#10360.00	48.1 PK	68.2	-20.1	1.66 H	204	34.1	14.0
6	15540.00	58.0 PK	74.0	-16.0	1.55 H	5	44.0	14.0
7	15540.00	45.6 AV	54.0	-8.4	1.55 H	5	31.6	14.0

Remarks:

1. Emission Level(dBuV/m) = Raw Value(dBuV) + Correction Factor(dB/m)
2. Correction Factor(dB/m) = Antenna Factor(dB/m) + Cable Factor(dB) – Pre-Amplifier Factor(dB)
3. Margin value = Emission Level – Limit value
4. The other emission levels were very low against the limit.
5. " * ": Fundamental frequency, the limit was restricted at the RF Output Power.
6. " # ": The radiated frequency is out of the restricted band.

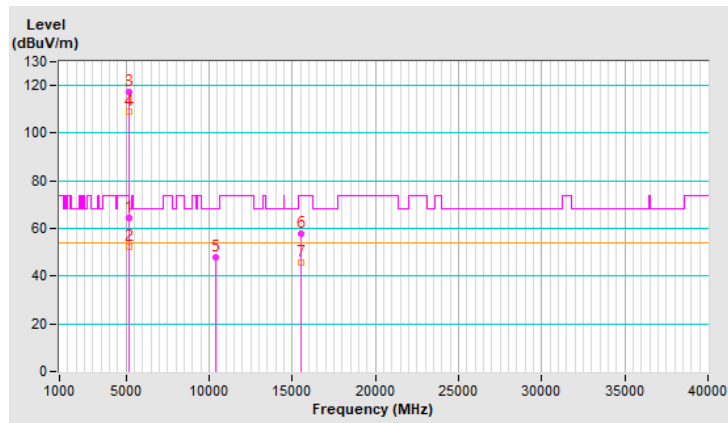

RF Mode	802.11a	Channel	CH 36 : 5180 MHz
Frequency Range	1 GHz ~ 40 GHz	Detector Function & Bandwidth	(PK) RB = 1 MHz, VB = 3 MHz (AV) RB = 1 MHz, VB = 10 Hz
Input Power	120 Vac, 60 Hz	Environmental Conditions	20°C, 70% RH
Tested By	Ryan Du		

Antenna Polarity & Test Distance : Vertical at 3 m								
No	Frequency (MHz)	Emission Level (dBuV/m)	Limit (dBuV/m)	Margin (dB)	Antenna Height (m)	Table Angle (Degree)	Raw Value (dBuV)	Correction Factor (dB/m)
1	5150.00	66.4 PK	74.0	-7.6	1.73 V	9	61.9	4.5
2	5150.00	53.8 AV	54.0	-0.2	1.73 V	9	49.3	4.5
3	*5180.00	120.3 PK			1.73 V	9	115.8	4.5
4	*5180.00	111.4 AV			1.73 V	9	106.9	4.5
5	#10360.00	48.4 PK	68.2	-19.8	1.75 V	224	34.4	14.0
6	15540.00	60.1 PK	74.0	-13.9	1.60 V	180	46.1	14.0
7	15540.00	47.3 AV	54.0	-6.7	1.60 V	180	33.3	14.0

Remarks:

1. Emission Level(dBuV/m) = Raw Value(dBuV) + Correction Factor(dB/m)
2. Correction Factor(dB/m) = Antenna Factor(dB/m) + Cable Factor(dB) – Pre-Amplifier Factor(dB)
3. Margin value = Emission Level – Limit value
4. The other emission levels were very low against the limit.
5. " * ": Fundamental frequency, the limit was restricted at the RF Output Power.
6. " # ": The radiated frequency is out of the restricted band.

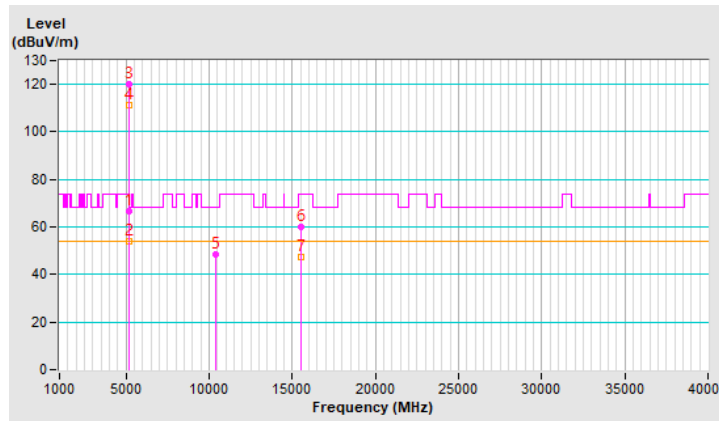

RF Mode	802.11a	Channel	CH 40 : 5200 MHz
Frequency Range	1 GHz ~ 40 GHz	Detector Function & Bandwidth	(PK) RB = 1 MHz, VB = 3 MHz (AV) RB = 1 MHz, VB = 10 Hz
Input Power	120 Vac, 60 Hz	Environmental Conditions	20°C, 70% RH
Tested By	Ryan Du		

Antenna Polarity & Test Distance : Horizontal at 3 m								
No	Frequency (MHz)	Emission Level (dBuV/m)	Limit (dBuV/m)	Margin (dB)	Antenna Height (m)	Table Angle (Degree)	Raw Value (dBuV)	Correction Factor (dB/m)
1	5150.00	59.5 PK	74.0	-14.5	2.38 H	207	55.0	4.5
2	5150.00	50.0 AV	54.0	-4.0	2.38 H	207	45.5	4.5
3	*5200.00	117.9 PK			2.38 H	207	113.6	4.3
4	*5200.00	109.3 AV			2.38 H	207	105.0	4.3
5	#10400.00	47.3 PK	68.2	-20.9	1.70 H	217	33.2	14.1
6	15600.00	58.4 PK	74.0	-15.6	1.62 H	35	44.1	14.3
7	15600.00	45.8 AV	54.0	-8.2	1.62 H	35	31.5	14.3

Remarks:

1. Emission Level(dBuV/m) = Raw Value(dBuV) + Correction Factor(dB/m)
2. Correction Factor(dB/m) = Antenna Factor(dB/m) + Cable Factor(dB) – Pre-Amplifier Factor(dB)
3. Margin value = Emission Level – Limit value
4. The other emission levels were very low against the limit.
5. " * ": Fundamental frequency, the limit was restricted at the RF Output Power.
6. " # ": The radiated frequency is out of the restricted band.

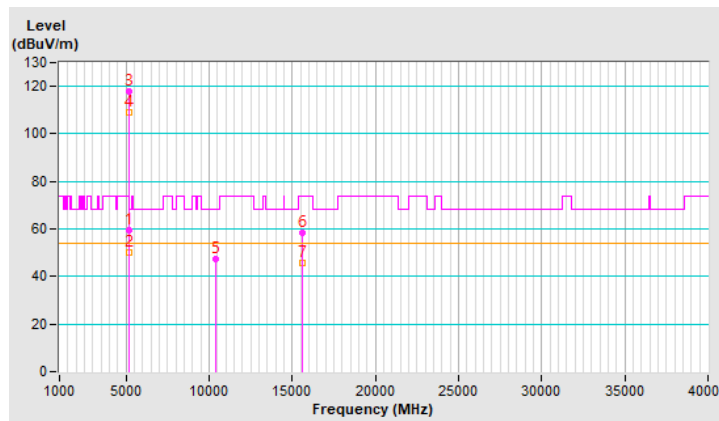

RF Mode	802.11a	Channel	CH 40 : 5200 MHz
Frequency Range	1 GHz ~ 40 GHz	Detector Function & Bandwidth	(PK) RB = 1 MHz, VB = 3 MHz (AV) RB = 1 MHz, VB = 10 Hz
Input Power	120 Vac, 60 Hz	Environmental Conditions	20°C, 70% RH
Tested By	Ryan Du		

Antenna Polarity & Test Distance : Vertical at 3 m								
No	Frequency (MHz)	Emission Level (dBuV/m)	Limit (dBuV/m)	Margin (dB)	Antenna Height (m)	Table Angle (Degree)	Raw Value (dBuV)	Correction Factor (dB/m)
1	5150.00	65.3 PK	74.0	-8.7	2.16 V	197	60.8	4.5
2	5150.00	53.7 AV	54.0	-0.3	2.16 V	197	49.2	4.5
3	*5200.00	123.5 PK			2.16 V	197	119.2	4.3
4	*5200.00	114.0 AV			2.16 V	197	109.7	4.3
5	#10400.00	47.8 PK	68.2	-20.4	1.77 V	214	33.7	14.1
6	15600.00	59.5 PK	74.0	-14.5	1.59 V	193	45.2	14.3
7	15600.00	47.0 AV	54.0	-7.0	1.59 V	193	32.7	14.3

Remarks:

1. Emission Level(dBuV/m) = Raw Value(dBuV) + Correction Factor(dB/m)
2. Correction Factor(dB/m) = Antenna Factor(dB/m) + Cable Factor(dB) – Pre-Amplifier Factor(dB)
3. Margin value = Emission Level – Limit value
4. The other emission levels were very low against the limit.
5. " * ": Fundamental frequency, the limit was restricted at the RF Output Power.
6. " # ": The radiated frequency is out of the restricted band.

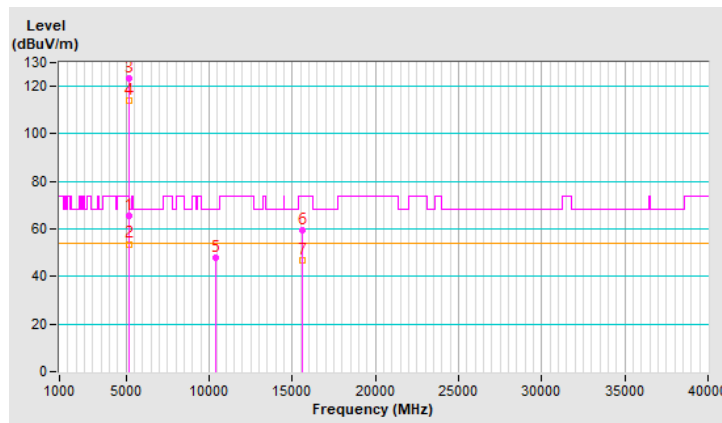

RF Mode	802.11a	Channel	CH 48 : 5240 MHz
Frequency Range	1 GHz ~ 40 GHz	Detector Function & Bandwidth	(PK) RB = 1 MHz, VB = 3 MHz (AV) RB = 1 MHz, VB = 10 Hz
Input Power	120 Vac, 60 Hz	Environmental Conditions	20°C, 70% RH
Tested By	Ryan Du		

Antenna Polarity & Test Distance : Horizontal at 3 m								
No	Frequency (MHz)	Emission Level (dBuV/m)	Limit (dBuV/m)	Margin (dB)	Antenna Height (m)	Table Angle (Degree)	Raw Value (dBuV)	Correction Factor (dB/m)
1	5150.00	53.6 PK	74.0	-20.4	2.35 H	188	49.1	4.5
2	5150.00	43.8 AV	54.0	-10.2	2.35 H	188	39.3	4.5
3	*5240.00	117.0 PK			2.35 H	188	113.0	4.0
4	*5240.00	108.5 AV			2.35 H	188	104.5	4.0
5	#10480.00	46.7 PK	68.2	-21.5	1.72 H	209	32.6	14.1
6	15720.00	58.2 PK	74.0	-15.8	1.66 H	42	43.8	14.4
7	15720.00	45.4 AV	54.0	-8.6	1.66 H	42	31.0	14.4

Remarks:

1. Emission Level(dBuV/m) = Raw Value(dBuV) + Correction Factor(dB/m)
2. Correction Factor(dB/m) = Antenna Factor(dB/m) + Cable Factor(dB) – Pre-Amplifier Factor(dB)
3. Margin value = Emission Level – Limit value
4. The other emission levels were very low against the limit.
5. " * " : Fundamental frequency, the limit was restricted at the RF Output Power.
6. " # " : The radiated frequency is out of the restricted band.

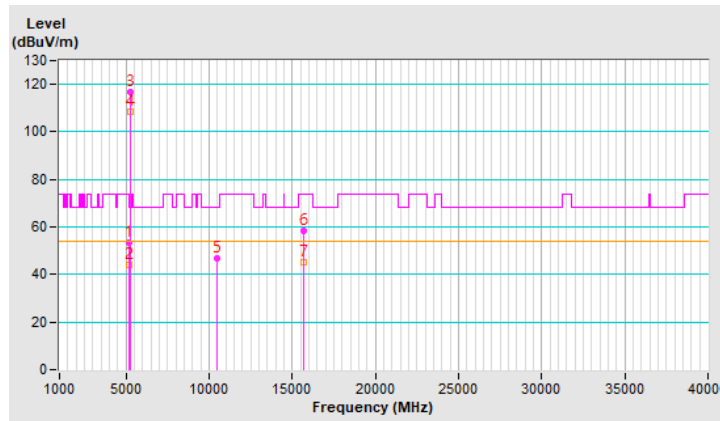

RF Mode	802.11a	Channel	CH 48 : 5240 MHz
Frequency Range	1 GHz ~ 40 GHz	Detector Function & Bandwidth	(PK) RB = 1 MHz, VB = 3 MHz (AV) RB = 1 MHz, VB = 10 Hz
Input Power	120 Vac, 60 Hz	Environmental Conditions	20°C, 70% RH
Tested By	Ryan Du		

Antenna Polarity & Test Distance : Vertical at 3 m								
No	Frequency (MHz)	Emission Level (dBuV/m)	Limit (dBuV/m)	Margin (dB)	Antenna Height (m)	Table Angle (Degree)	Raw Value (dBuV)	Correction Factor (dB/m)
1	5145.58	57.1 PK	74.0	-16.9	2.48 V	11	52.6	4.5
2	5145.58	48.2 AV	54.0	-5.8	2.48 V	11	43.7	4.5
3	*5240.00	121.6 PK			2.48 V	11	117.6	4.0
4	*5240.00	112.4 AV			2.48 V	11	108.4	4.0
5	#10480.00	47.4 PK	68.2	-20.8	1.78 V	226	33.3	14.1
6	15720.00	59.0 PK	74.0	-15.0	1.55 V	188	44.6	14.4
7	15720.00	46.7 AV	54.0	-7.3	1.55 V	188	32.3	14.4

Remarks:

1. Emission Level(dBuV/m) = Raw Value(dBuV) + Correction Factor(dB/m)
2. Correction Factor(dB/m) = Antenna Factor(dB/m) + Cable Factor(dB) – Pre-Amplifier Factor(dB)
3. Margin value = Emission Level – Limit value
4. The other emission levels were very low against the limit.
5. " * " : Fundamental frequency, the limit was restricted at the RF Output Power.
6. " # " : The radiated frequency is out of the restricted band.

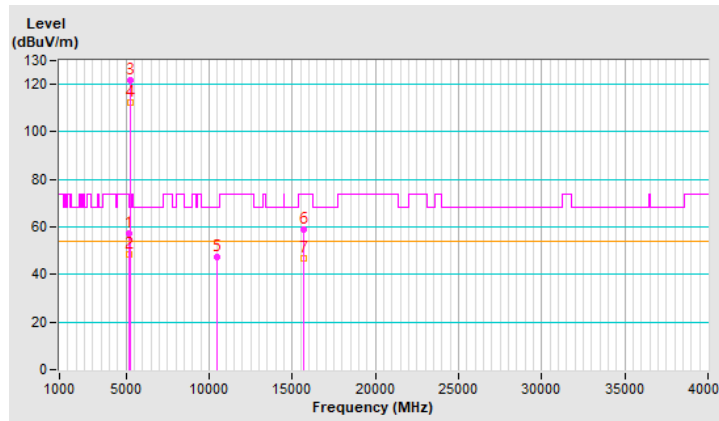

RF Mode	802.11a	Channel	CH 52 : 5260 MHz
Frequency Range	1 GHz ~ 40 GHz	Detector Function & Bandwidth	(PK) RB = 1 MHz, VB = 3 MHz (AV) RB = 1 MHz, VB = 10 Hz
Input Power	120 Vac, 60 Hz	Environmental Conditions	20°C, 70% RH
Tested By	Ryan Du		

Antenna Polarity & Test Distance : Horizontal at 3 m

No	Frequency (MHz)	Emission Level (dBuV/m)	Limit (dBuV/m)	Margin (dB)	Antenna Height (m)	Table Angle (Degree)	Raw Value (dBuV)	Correction Factor (dB/m)
1	*5260.00	117.1 PK			2.32 H	195	113.1	4.0
2	*5260.00	108.6 AV			2.32 H	195	104.6	4.0
3	5350.00	54.3 PK	74.0	-19.7	2.32 H	195	50.1	4.2
4	5350.00	44.6 AV	54.0	-9.4	2.32 H	195	40.4	4.2
5	#10520.00	47.1 PK	68.2	-21.1	1.75 H	220	32.9	14.2
6	15780.00	58.3 PK	74.0	-15.7	1.61 H	27	43.8	14.5
7	15780.00	45.8 AV	54.0	-8.2	1.61 H	27	31.3	14.5

Remarks:

1. Emission Level(dBuV/m) = Raw Value(dBuV) + Correction Factor(dB/m)
2. Correction Factor(dB/m) = Antenna Factor(dB/m) + Cable Factor(dB) – Pre-Amplifier Factor(dB)
3. Margin value = Emission Level – Limit value
4. The other emission levels were very low against the limit.
5. " * " : Fundamental frequency, the limit was restricted at the RF Output Power.
6. " # " : The radiated frequency is out of the restricted band.

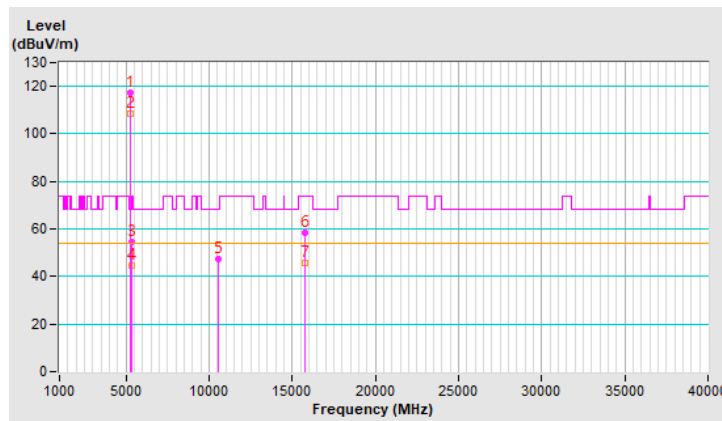

RF Mode	802.11a	Channel	CH 52 : 5260 MHz
Frequency Range	1 GHz ~ 40 GHz	Detector Function & Bandwidth	(PK) RB = 1 MHz, VB = 3 MHz (AV) RB = 1 MHz, VB = 10 Hz
Input Power	120 Vac, 60 Hz	Environmental Conditions	20°C, 70% RH
Tested By	Ryan Du		

Antenna Polarity & Test Distance : Vertical at 3 m								
No	Frequency (MHz)	Emission Level (dBuV/m)	Limit (dBuV/m)	Margin (dB)	Antenna Height (m)	Table Angle (Degree)	Raw Value (dBuV)	Correction Factor (dB/m)
1	*5260.00	121.9 PK			2.13 V	11	117.9	4.0
2	*5260.00	112.8 AV			2.13 V	11	108.8	4.0
3	5360.64	59.4 PK	74.0	-14.6	2.13 V	11	55.2	4.2
4	5360.64	49.7 AV	54.0	-4.3	2.13 V	11	45.5	4.2
5	#10520.00	47.8 PK	68.2	-20.4	1.77 V	219	33.6	14.2
6	15780.00	59.5 PK	74.0	-14.5	1.54 V	182	45.0	14.5
7	15780.00	46.8 AV	54.0	-7.2	1.54 V	182	32.3	14.5

Remarks:

1. Emission Level(dBuV/m) = Raw Value(dBuV) + Correction Factor(dB/m)
2. Correction Factor(dB/m) = Antenna Factor(dB/m) + Cable Factor(dB) – Pre-Amplifier Factor(dB)
3. Margin value = Emission Level – Limit value
4. The other emission levels were very low against the limit.
5. " * " : Fundamental frequency, the limit was restricted at the RF Output Power.
6. " # " : The radiated frequency is out of the restricted band.

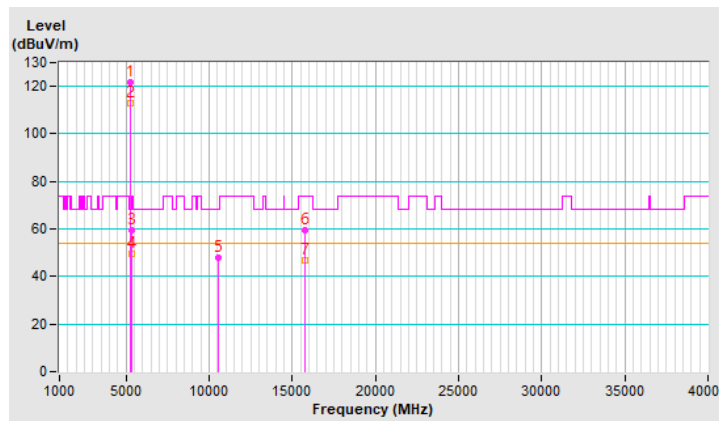

RF Mode	802.11a	Channel	CH 60 : 5300 MHz
Frequency Range	1 GHz ~ 40 GHz	Detector Function & Bandwidth	(PK) RB = 1 MHz, VB = 3 MHz (AV) RB = 1 MHz, VB = 10 Hz
Input Power	120 Vac, 60 Hz	Environmental Conditions	20°C, 70% RH
Tested By	Ryan Du		

Antenna Polarity & Test Distance : Horizontal at 3 m

No	Frequency (MHz)	Emission Level (dBuV/m)	Limit (dBuV/m)	Margin (dB)	Antenna Height (m)	Table Angle (Degree)	Raw Value (dBuV)	Correction Factor (dB/m)
1	*5300.00	117.3 PK			2.34 H	214	113.3	4.0
2	*5300.00	108.7 AV			2.34 H	214	104.7	4.0
3	10600.00	47.6 PK	74.0	-26.4	1.64 H	230	34.0	13.6
4	10600.00	36.7 AV	54.0	-17.3	1.64 H	230	23.1	13.6
5	15900.00	58.4 PK	74.0	-15.6	1.68 H	32	44.0	14.4
6	15900.00	45.5 AV	54.0	-8.5	1.68 H	32	31.1	14.4

Remarks:

1. Emission Level(dBuV/m) = Raw Value(dBuV) + Correction Factor(dB/m)
2. Correction Factor(dB/m) = Antenna Factor(dB/m) + Cable Factor(dB) – Pre-Amplifier Factor(dB)
3. Margin value = Emission Level – Limit value
4. The other emission levels were very low against the limit.
5. " * " : Fundamental frequency, the limit was restricted at the RF Output Power.

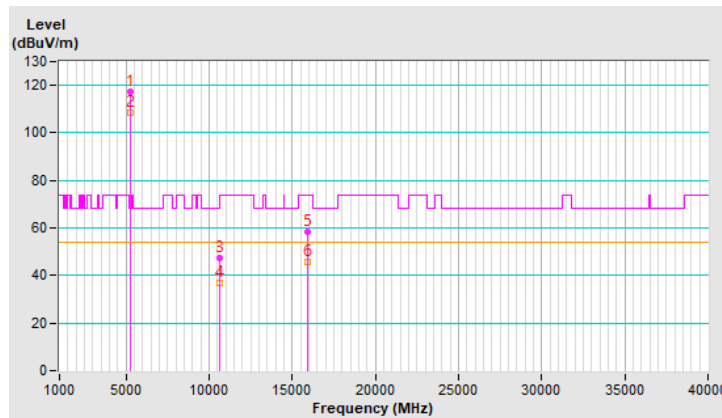

RF Mode	802.11a	Channel	CH 60 : 5300 MHz
Frequency Range	1 GHz ~ 40 GHz	Detector Function & Bandwidth	(PK) RB = 1 MHz, VB = 3 MHz (AV) RB = 1 MHz, VB = 10 Hz
Input Power	120 Vac, 60 Hz	Environmental Conditions	20°C, 70% RH
Tested By	Ryan Du		

Antenna Polarity & Test Distance : Vertical at 3 m								
No	Frequency (MHz)	Emission Level (dBuV/m)	Limit (dBuV/m)	Margin (dB)	Antenna Height (m)	Table Angle (Degree)	Raw Value (dBuV)	Correction Factor (dB/m)
1	*5300.00	122.1 PK			1.84 V	14	118.1	4.0
2	*5300.00	113.0 AV			1.84 V	14	109.0	4.0
3	10600.00	47.8 PK	74.0	-26.2	1.82 V	206	34.2	13.6
4	10600.00	36.6 AV	54.0	-17.4	1.82 V	206	23.0	13.6
5	15900.00	59.5 PK	74.0	-14.5	1.57 V	189	45.1	14.4
6	15900.00	47.2 AV	54.0	-6.8	1.57 V	189	32.8	14.4

Remarks:

1. Emission Level(dBuV/m) = Raw Value(dBuV) + Correction Factor(dB/m)
2. Correction Factor(dB/m) = Antenna Factor(dB/m) + Cable Factor(dB) – Pre-Amplifier Factor(dB)
3. Margin value = Emission Level – Limit value
4. The other emission levels were very low against the limit.
5. " * " : Fundamental frequency, the limit was restricted at the RF Output Power.

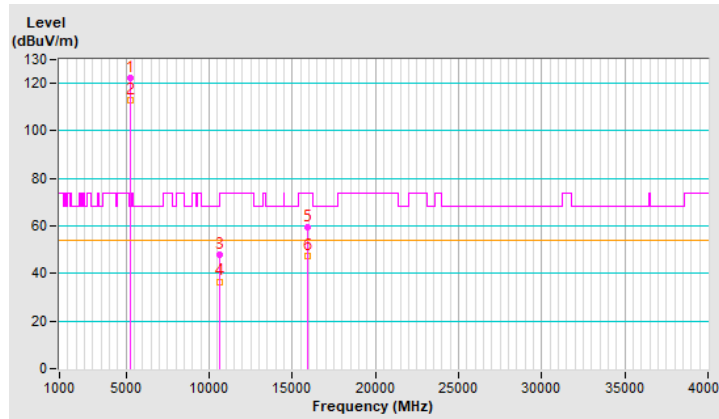

RF Mode	802.11a	Channel	CH 64 : 5320 MHz
Frequency Range	1 GHz ~ 40 GHz	Detector Function & Bandwidth	(PK) RB = 1 MHz, VB = 3 MHz (AV) RB = 1 MHz, VB = 10 Hz
Input Power	120 Vac, 60 Hz	Environmental Conditions	20°C, 70% RH
Tested By	Ryan Du		

Antenna Polarity & Test Distance : Horizontal at 3 m

No	Frequency (MHz)	Emission Level (dBuV/m)	Limit (dBuV/m)	Margin (dB)	Antenna Height (m)	Table Angle (Degree)	Raw Value (dBuV)	Correction Factor (dB/m)
1	*5320.00	115.3 PK			1.45 H	139	111.2	4.1
2	*5320.00	106.6 AV			1.45 H	139	102.5	4.1
3	5350.00	56.6 PK	74.0	-17.4	1.45 H	139	52.4	4.2
4	5350.00	45.5 AV	54.0	-8.5	1.45 H	139	41.3	4.2
5	10640.00	46.9 PK	74.0	-27.1	1.69 H	205	33.2	13.7
6	10640.00	35.9 AV	54.0	-18.1	1.69 H	205	22.2	13.7
7	15960.00	58.6 PK	74.0	-15.4	1.63 H	33	43.7	14.9
8	15960.00	46.2 AV	54.0	-7.8	1.63 H	33	31.3	14.9

Remarks:

1. Emission Level(dBuV/m) = Raw Value(dBuV) + Correction Factor(dB/m)
2. Correction Factor(dB/m) = Antenna Factor(dB/m) + Cable Factor(dB) – Pre-Amplifier Factor(dB)
3. Margin value = Emission Level – Limit value
4. The other emission levels were very low against the limit.
5. " * " : Fundamental frequency, the limit was restricted at the RF Output Power.

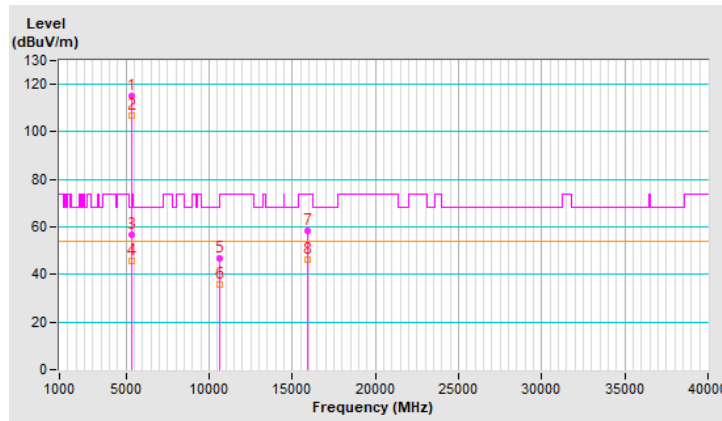

RF Mode	802.11a	Channel	CH 64 : 5320 MHz
Frequency Range	1 GHz ~ 40 GHz	Detector Function & Bandwidth	(PK) RB = 1 MHz, VB = 3 MHz (AV) RB = 1 MHz, VB = 10 Hz
Input Power	120 Vac, 60 Hz	Environmental Conditions	20°C, 70% RH
Tested By	Ryan Du		

Antenna Polarity & Test Distance : Vertical at 3 m								
No	Frequency (MHz)	Emission Level (dBuV/m)	Limit (dBuV/m)	Margin (dB)	Antenna Height (m)	Table Angle (Degree)	Raw Value (dBuV)	Correction Factor (dB/m)
1	*5320.00	120.6 PK			1.98 V	13	116.5	4.1
2	*5320.00	111.5 AV			1.98 V	13	107.4	4.1
3	5350.00	62.3 PK	74.0	-11.7	1.98 V	13	58.1	4.2
4	5350.00	53.8 AV	54.0	-0.2	1.98 V	13	49.6	4.2
5	10640.00	47.9 PK	74.0	-26.1	1.81 V	202	34.2	13.7
6	10640.00	36.5 AV	54.0	-17.5	1.81 V	202	22.8	13.7
7	15960.00	59.5 PK	74.0	-14.5	1.62 V	190	44.6	14.9
8	15960.00	46.8 AV	54.0	-7.2	1.62 V	190	31.9	14.9

Remarks:

1. Emission Level(dBuV/m) = Raw Value(dBuV) + Correction Factor(dB/m)
2. Correction Factor(dB/m) = Antenna Factor(dB/m) + Cable Factor(dB) – Pre-Amplifier Factor(dB)
3. Margin value = Emission Level – Limit value
4. The other emission levels were very low against the limit.
5. " * " : Fundamental frequency, the limit was restricted at the RF Output Power.

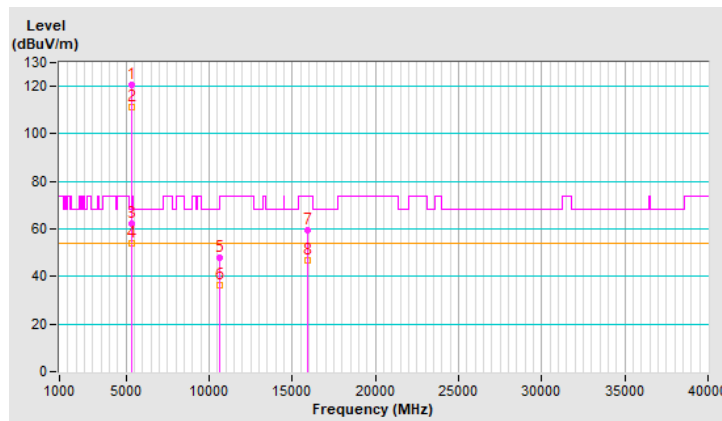

RF Mode	802.11a	Channel	CH 100 : 5500 MHz
Frequency Range	1 GHz ~ 40 GHz	Detector Function & Bandwidth	(PK) RB = 1 MHz, VB = 3 MHz (AV) RB = 1 MHz, VB = 10 Hz
Input Power	120 Vac, 60 Hz	Environmental Conditions	20°C, 70% RH
Tested By	Ryan Du		

Antenna Polarity & Test Distance : Horizontal at 3 m

No	Frequency (MHz)	Emission Level (dBuV/m)	Limit (dBuV/m)	Margin (dB)	Antenna Height (m)	Table Angle (Degree)	Raw Value (dBuV)	Correction Factor (dB/m)
1	5458.97	58.0 PK	74.0	-16.0	1.51 H	149	53.6	4.4
2	5458.97	47.0 AV	54.0	-7.0	1.51 H	149	42.6	4.4
3	#5464.82	66.5 PK	68.2	-1.7	1.51 H	149	62.1	4.4
4	*5500.00	117.6 PK			1.51 H	149	113.1	4.5
5	*5500.00	108.9 AV			1.51 H	149	104.4	4.5
6	11000.00	47.4 PK	74.0	-26.6	1.74 H	230	32.8	14.6
7	11000.00	36.2 AV	54.0	-17.8	1.74 H	230	21.6	14.6
8	#16500.00	58.6 PK	68.2	-9.6	1.63 H	32	41.8	16.8

Remarks:

1. Emission Level(dBuV/m) = Raw Value(dBuV) + Correction Factor(dB/m)
2. Correction Factor(dB/m) = Antenna Factor(dB/m) + Cable Factor(dB) – Pre-Amplifier Factor(dB)
3. Margin value = Emission Level – Limit value
4. The other emission levels were very low against the limit.
5. " * " : Fundamental frequency, the limit was restricted at the RF Output Power.
6. " # " : The radiated frequency is out of the restricted band.

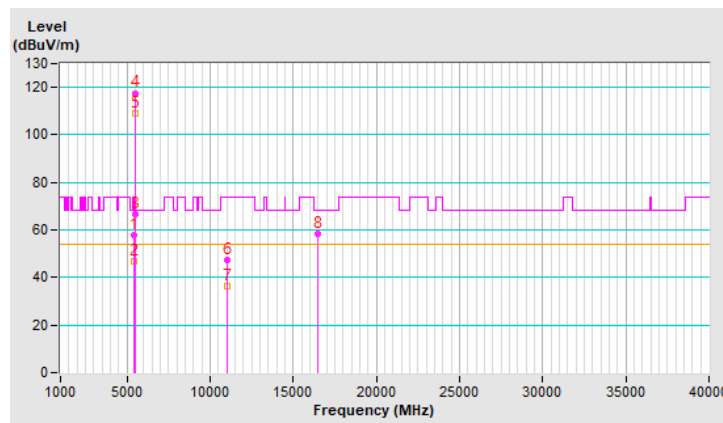

RF Mode	802.11a	Channel	CH 100 : 5500 MHz
Frequency Range	1 GHz ~ 40 GHz	Detector Function & Bandwidth	(PK) RB = 1 MHz, VB = 3 MHz (AV) RB = 1 MHz, VB = 10 Hz
Input Power	120 Vac, 60 Hz	Environmental Conditions	20°C, 70% RH
Tested By	Ryan Du		

Antenna Polarity & Test Distance : Vertical at 3 m								
No	Frequency (MHz)	Emission Level (dBuV/m)	Limit (dBuV/m)	Margin (dB)	Antenna Height (m)	Table Angle (Degree)	Raw Value (dBuV)	Correction Factor (dB/m)
1	5459.50	63.2 PK	74.0	-10.8	1.87 V	9	58.8	4.4
2	5459.50	51.5 AV	54.0	-2.5	1.87 V	9	47.1	4.4
3	#5470.00	67.9 PK	68.2	-0.3	1.87 V	9	63.5	4.4
4	*5500.00	121.2 PK			1.87 V	9	116.7	4.5
5	*5500.00	112.3 AV			1.87 V	9	107.8	4.5
6	11000.00	47.8 PK	74.0	-26.2	1.79 V	201	33.2	14.6
7	11000.00	36.7 AV	54.0	-17.3	1.79 V	201	22.1	14.6
8	#16500.00	59.6 PK	68.2	-8.6	1.62 V	179	42.8	16.8

Remarks:

1. Emission Level(dBuV/m) = Raw Value(dBuV) + Correction Factor(dB/m)
2. Correction Factor(dB/m) = Antenna Factor(dB/m) + Cable Factor(dB) – Pre-Amplifier Factor(dB)
3. Margin value = Emission Level – Limit value
4. The other emission levels were very low against the limit.
5. " * " : Fundamental frequency, the limit was restricted at the RF Output Power.
6. " # " : The radiated frequency is out of the restricted band.

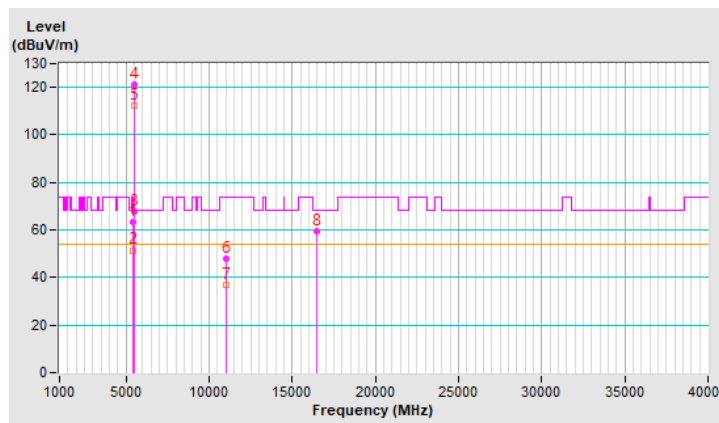

RF Mode	802.11a	Channel	CH 116 : 5580 MHz
Frequency Range	1 GHz ~ 40 GHz	Detector Function & Bandwidth	(PK) RB = 1 MHz, VB = 3 MHz (AV) RB = 1 MHz, VB = 10 Hz
Input Power	120 Vac, 60 Hz	Environmental Conditions	20°C, 70% RH
Tested By	Ryan Du		

Antenna Polarity & Test Distance : Horizontal at 3 m

No	Frequency (MHz)	Emission Level (dBuV/m)	Limit (dBuV/m)	Margin (dB)	Antenna Height (m)	Table Angle (Degree)	Raw Value (dBuV)	Correction Factor (dB/m)
1	*5580.00	117.8 PK			1.54 H	148	113.4	4.4
2	*5580.00	109.4 AV			1.54 H	148	105.0	4.4
3	11160.00	46.8 PK	74.0	-27.2	1.71 H	225	32.8	14.0
4	11160.00	36.0 AV	54.0	-18.0	1.71 H	225	22.0	14.0
5	#16740.00	58.4 PK	68.2	-9.8	1.67 H	50	40.1	18.3

Remarks:

1. Emission Level(dBuV/m) = Raw Value(dBuV) + Correction Factor(dB/m)
2. Correction Factor(dB/m) = Antenna Factor(dB/m) + Cable Factor(dB) – Pre-Amplifier Factor(dB)
3. Margin value = Emission Level – Limit value
4. The other emission levels were very low against the limit.
5. " * " : Fundamental frequency, the limit was restricted at the RF Output Power.
6. " # " : The radiated frequency is out of the restricted band.

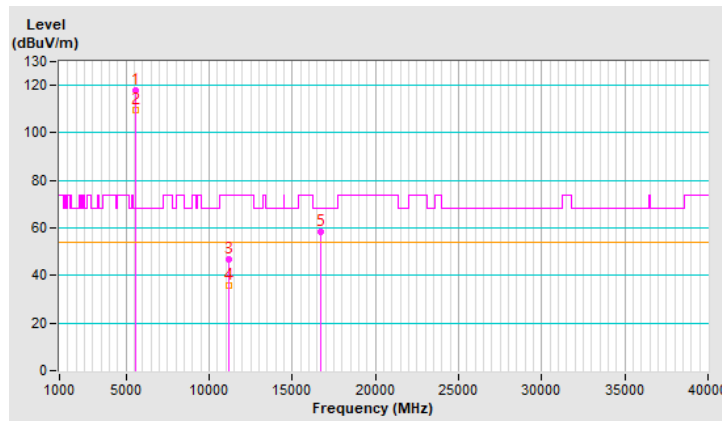

RF Mode	802.11a	Channel	CH 116 : 5580 MHz
Frequency Range	1 GHz ~ 40 GHz	Detector Function & Bandwidth	(PK) RB = 1 MHz, VB = 3 MHz (AV) RB = 1 MHz, VB = 10 Hz
Input Power	120 Vac, 60 Hz	Environmental Conditions	20°C, 70% RH
Tested By	Ryan Du		

Antenna Polarity & Test Distance : Vertical at 3 m

No	Frequency (MHz)	Emission Level (dBuV/m)	Limit (dBuV/m)	Margin (dB)	Antenna Height (m)	Table Angle (Degree)	Raw Value (dBuV)	Correction Factor (dB/m)
1	*5580.00	121.1 PK			1.76 V	33	116.7	4.4
2	*5580.00	111.8 AV			1.76 V	33	107.4	4.4
3	11160.00	48.0 PK	74.0	-26.0	1.71 V	206	34.0	14.0
4	11160.00	36.6 AV	54.0	-17.4	1.71 V	206	22.6	14.0
5	#16740.00	59.2 PK	68.2	-9.0	1.64 V	196	40.9	18.3

Remarks:

1. Emission Level(dBuV/m) = Raw Value(dBuV) + Correction Factor(dB/m)
2. Correction Factor(dB/m) = Antenna Factor(dB/m) + Cable Factor(dB) – Pre-Amplifier Factor(dB)
3. Margin value = Emission Level – Limit value
4. The other emission levels were very low against the limit.
5. " * " : Fundamental frequency, the limit was restricted at the RF Output Power.
6. " # " : The radiated frequency is out of the restricted band.

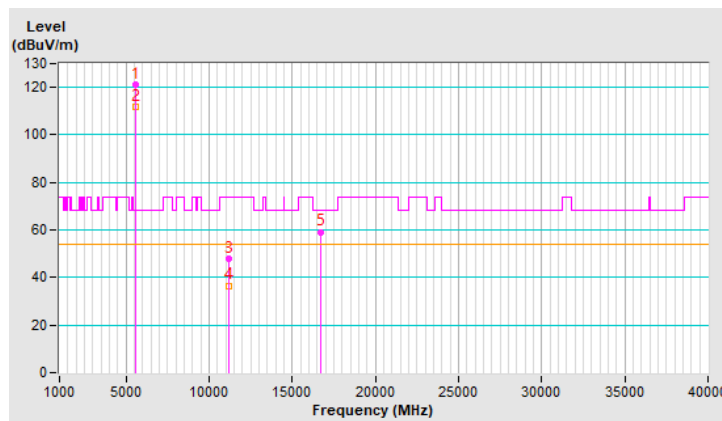

RF Mode	802.11a	Channel	CH 140 : 5700 MHz
Frequency Range	1 GHz ~ 40 GHz	Detector Function & Bandwidth	(PK) RB = 1 MHz, VB = 3 MHz (AV) RB = 1 MHz, VB = 10 Hz
Input Power	120 Vac, 60 Hz	Environmental Conditions	20°C, 70% RH
Tested By	Ryan Du		

Antenna Polarity & Test Distance : Horizontal at 3 m								
No	Frequency (MHz)	Emission Level (dBuV/m)	Limit (dBuV/m)	Margin (dB)	Antenna Height (m)	Table Angle (Degree)	Raw Value (dBuV)	Correction Factor (dB/m)
1	*5700.00	118.3 PK			1.51 H	154	113.8	4.5
2	*5700.00	109.3 AV			1.51 H	154	104.8	4.5
3	#5726.10	64.5 PK	68.2	-3.7	1.51 H	154	59.9	4.6
4	11400.00	47.3 PK	74.0	-26.7	1.74 H	230	32.3	15.0
5	11400.00	36.2 AV	54.0	-17.8	1.74 H	230	21.2	15.0
6	#17100.00	58.5 PK	68.2	-9.7	1.68 H	42	39.2	19.3

Remarks:

1. Emission Level(dBuV/m) = Raw Value(dBuV) + Correction Factor(dB/m)
2. Correction Factor(dB/m) = Antenna Factor(dB/m) + Cable Factor(dB) – Pre-Amplifier Factor(dB)
3. Margin value = Emission Level – Limit value
4. The other emission levels were very low against the limit.
5. " * " : Fundamental frequency, the limit was restricted at the RF Output Power.
6. " # " : The radiated frequency is out of the restricted band.

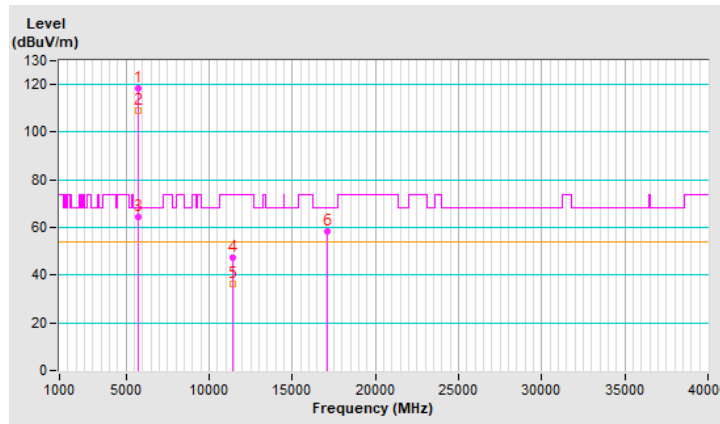

RF Mode	802.11a	Channel	CH 140 : 5700 MHz
Frequency Range	1 GHz ~ 40 GHz	Detector Function & Bandwidth	(PK) RB = 1 MHz, VB = 3 MHz (AV) RB = 1 MHz, VB = 10 Hz
Input Power	120 Vac, 60 Hz	Environmental Conditions	20°C, 70% RH
Tested By	Ryan Du		

Antenna Polarity & Test Distance : Vertical at 3 m								
No	Frequency (MHz)	Emission Level (dBuV/m)	Limit (dBuV/m)	Margin (dB)	Antenna Height (m)	Table Angle (Degree)	Raw Value (dBuV)	Correction Factor (dB/m)
1	*5700.00	116.6 PK			1.92 V	11	112.1	4.5
2	*5700.00	107.8 AV			1.92 V	11	103.3	4.5
3	#5726.10	67.8 PK	68.2	-0.4	1.92 V	11	63.2	4.6
4	11400.00	48.6 PK	74.0	-25.4	1.74 V	230	33.6	15.0
5	11400.00	37.0 AV	54.0	-17.0	1.74 V	230	22.0	15.0
6	#17100.00	59.6 PK	68.2	-8.6	1.60 V	201	40.3	19.3

Remarks:

1. Emission Level(dBuV/m) = Raw Value(dBuV) + Correction Factor(dB/m)
2. Correction Factor(dB/m) = Antenna Factor(dB/m) + Cable Factor(dB) – Pre-Amplifier Factor(dB)
3. Margin value = Emission Level – Limit value
4. The other emission levels were very low against the limit.
5. " * " : Fundamental frequency, the limit was restricted at the RF Output Power.
6. " # " : The radiated frequency is out of the restricted band.

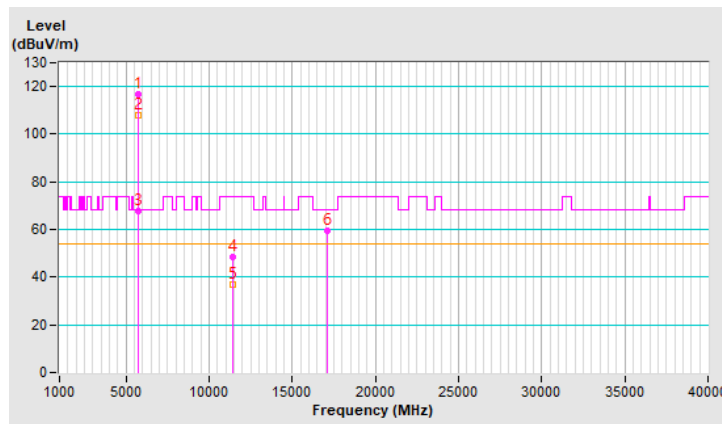

RF Mode	802.11a	Channel	CH 144 : 5720 MHz
Frequency Range	1 GHz ~ 40 GHz	Detector Function & Bandwidth	(PK) RB = 1 MHz, VB = 3 MHz (AV) RB = 1 MHz, VB = 10 Hz
Input Power	120 Vac, 60 Hz	Environmental Conditions	20°C, 70% RH
Tested By	Ryan Du		

Antenna Polarity & Test Distance : Horizontal at 3 m

No	Frequency (MHz)	Emission Level (dBuV/m)	Limit (dBuV/m)	Margin (dB)	Antenna Height (m)	Table Angle (Degree)	Raw Value (dBuV)	Correction Factor (dB/m)
1	*5720.00	117.9 PK			1.45 H	159	113.3	4.6
2	*5720.00	109.3 AV			1.45 H	159	104.7	4.6
3	11440.00	46.7 PK	74.0	-27.3	1.68 H	215	31.8	14.9
4	11440.00	36.0 AV	54.0	-18.0	1.68 H	215	21.1	14.9
5	#17160.00	58.6 PK	68.2	-9.6	1.60 H	51	39.5	19.1

Remarks:

1. Emission Level(dBuV/m) = Raw Value(dBuV) + Correction Factor(dB/m)
2. Correction Factor(dB/m) = Antenna Factor(dB/m) + Cable Factor(dB) – Pre-Amplifier Factor(dB)
3. Margin value = Emission Level – Limit value
4. The other emission levels were very low against the limit.
5. " * " : Fundamental frequency, the limit was restricted at the RF Output Power.
6. " # " : The radiated frequency is out of the restricted band.

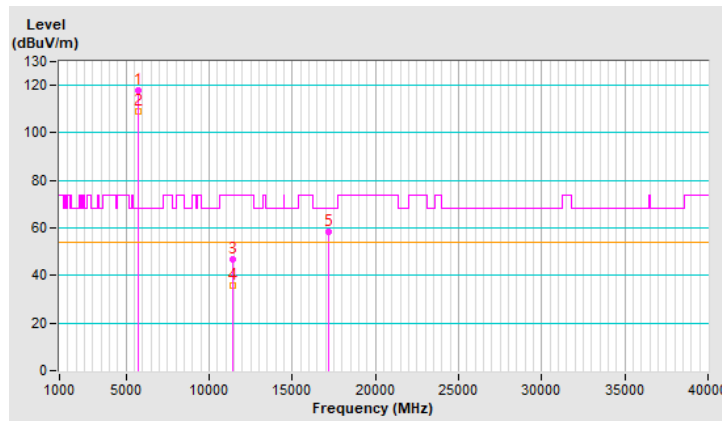

RF Mode	802.11a	Channel	CH 144 : 5720 MHz
Frequency Range	1 GHz ~ 40 GHz	Detector Function & Bandwidth	(PK) RB = 1 MHz, VB = 3 MHz (AV) RB = 1 MHz, VB = 10 Hz
Input Power	120 Vac, 60 Hz	Environmental Conditions	20°C, 70% RH
Tested By	Ryan Du		

Antenna Polarity & Test Distance : Vertical at 3 m								
No	Frequency (MHz)	Emission Level (dBuV/m)	Limit (dBuV/m)	Margin (dB)	Antenna Height (m)	Table Angle (Degree)	Raw Value (dBuV)	Correction Factor (dB/m)
1	*5720.00	121.2 PK			1.71 V	21	116.6	4.6
2	*5720.00	112.1 AV			1.71 V	21	107.5	4.6
3	11440.00	47.8 PK	74.0	-26.2	1.77 V	208	32.9	14.9
4	11440.00	36.4 AV	54.0	-17.6	1.77 V	208	21.5	14.9
5	#17160.00	59.2 PK	68.2	-9.0	1.54 V	178	40.1	19.1

Remarks:

1. Emission Level(dBuV/m) = Raw Value(dBuV) + Correction Factor(dB/m)
2. Correction Factor(dB/m) = Antenna Factor(dB/m) + Cable Factor(dB) – Pre-Amplifier Factor(dB)
3. Margin value = Emission Level – Limit value
4. The other emission levels were very low against the limit.
5. " * " : Fundamental frequency, the limit was restricted at the RF Output Power.
6. " # " : The radiated frequency is out of the restricted band.

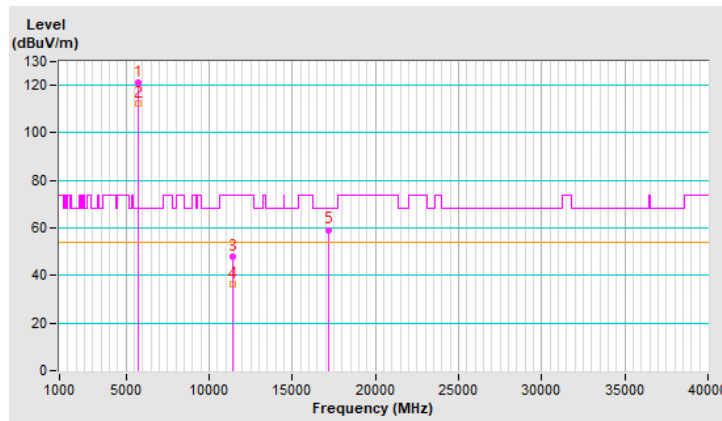

RF Mode	802.11a	Channel	CH 149 : 5745 MHz
Frequency Range	1 GHz ~ 40 GHz	Detector Function & Bandwidth	(PK) RB = 1 MHz, VB = 3 MHz (AV) RB = 1 MHz, VB = 10 Hz
Input Power	120 Vac, 60 Hz	Environmental Conditions	20°C, 70% RH
Tested By	Ryan Du		

Antenna Polarity & Test Distance : Horizontal at 3 m

No	Frequency (MHz)	Emission Level (dBuV/m)	Limit (dBuV/m)	Margin (dB)	Antenna Height (m)	Table Angle (Degree)	Raw Value (dBuV)	Correction Factor (dB/m)
1	#5648.04	59.2 PK	68.2	-9.0	1.52 H	156	54.5	4.7
2	*5745.00	118.2 PK			1.52 H	156	113.6	4.6
3	*5745.00	109.2 AV			1.52 H	156	104.6	4.6
4	#5951.53	53.2 PK	68.2	-15.0	1.52 H	156	48.1	5.1
5	11490.00	47.8 PK	74.0	-26.2	1.67 H	208	32.9	14.9
6	11490.00	36.7 AV	54.0	-17.3	1.67 H	208	21.8	14.9
7	#17235.00	58.7 PK	68.2	-9.5	1.54 H	3	39.9	18.8

Remarks:

1. Emission Level(dBuV/m) = Raw Value(dBuV) + Correction Factor(dB/m)
2. Correction Factor(dB/m) = Antenna Factor(dB/m) + Cable Factor(dB) – Pre-Amplifier Factor(dB)
3. Margin value = Emission Level – Limit value
4. The other emission levels were very low against the limit.
5. " * " : Fundamental frequency, the limit was restricted at the RF Output Power.
6. " # " : The radiated frequency is out of the restricted band.

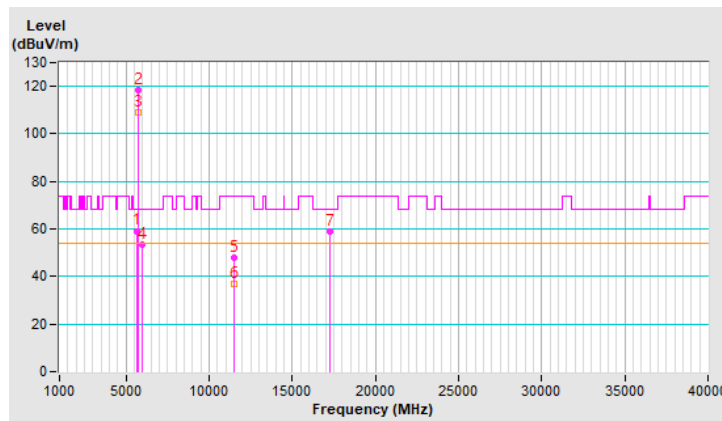

RF Mode	802.11a	Channel	CH 149 : 5745 MHz
Frequency Range	1 GHz ~ 40 GHz	Detector Function & Bandwidth	(PK) RB = 1 MHz, VB = 3 MHz (AV) RB = 1 MHz, VB = 10 Hz
Input Power	120 Vac, 60 Hz	Environmental Conditions	20°C, 70% RH
Tested By	Ryan Du		

Antenna Polarity & Test Distance : Vertical at 3 m								
No	Frequency (MHz)	Emission Level (dBuV/m)	Limit (dBuV/m)	Margin (dB)	Antenna Height (m)	Table Angle (Degree)	Raw Value (dBuV)	Correction Factor (dB/m)
1	#5637.54	67.7 PK	68.2	-0.5	1.31 V	5	63.1	4.6
2	*5745.00	124.6 PK			1.31 V	5	120.0	4.6
3	*5745.00	114.6 AV			1.31 V	5	110.0	4.6
4	#5927.30	56.4 PK	68.2	-11.8	1.31 V	5	51.3	5.1
5	11490.00	48.9 PK	74.0	-25.1	1.35 V	133	34.0	14.9
6	11490.00	37.5 AV	54.0	-16.5	1.35 V	133	22.6	14.9
7	#17235.00	59.3 PK	68.2	-8.9	1.37 V	318	40.5	18.8

Remarks:

1. Emission Level(dBuV/m) = Raw Value(dBuV) + Correction Factor(dB/m)
2. Correction Factor(dB/m) = Antenna Factor(dB/m) + Cable Factor(dB) – Pre-Amplifier Factor(dB)
3. Margin value = Emission Level – Limit value
4. The other emission levels were very low against the limit.
5. " * " : Fundamental frequency, the limit was restricted at the RF Output Power.
6. " # " : The radiated frequency is out of the restricted band.

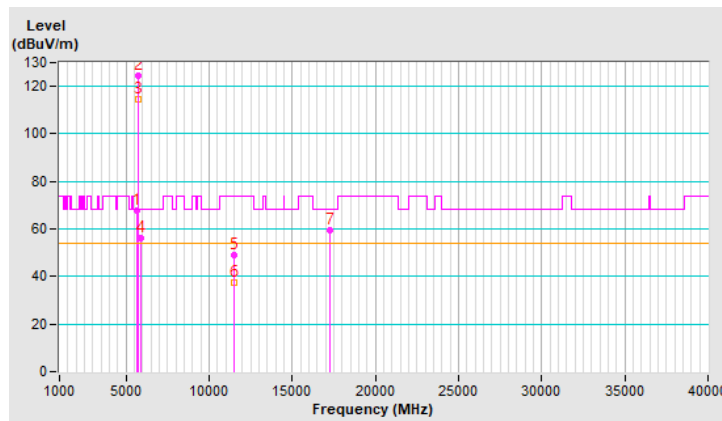

RF Mode	802.11a	Channel	CH 157 : 5785 MHz
Frequency Range	1 GHz ~ 40 GHz	Detector Function & Bandwidth	(PK) RB = 1 MHz, VB = 3 MHz (AV) RB = 1 MHz, VB = 10 Hz
Input Power	120 Vac, 60 Hz	Environmental Conditions	20°C, 70% RH
Tested By	Ryan Du		

Antenna Polarity & Test Distance : Horizontal at 3 m

No	Frequency (MHz)	Emission Level (dBUV/m)	Limit (dBUV/m)	Margin (dB)	Antenna Height (m)	Table Angle (Degree)	Raw Value (dBUV)	Correction Factor (dB/m)
1	#5591.47	55.7 PK	68.2	-12.5	1.46 H	155	51.4	4.3
2	*5785.00	118.2 PK			1.46 H	155	113.4	4.8
3	*5785.00	109.6 AV			1.46 H	155	104.8	4.8
4	#5932.06	53.3 PK	68.2	-14.9	1.46 H	155	48.2	5.1
5	11570.00	47.0 PK	74.0	-27.0	1.73 H	223	32.3	14.7
6	11570.00	36.0 AV	54.0	-18.0	1.73 H	223	21.3	14.7
7	#17355.00	58.5 PK	68.2	-9.7	1.68 H	48	39.7	18.8

Remarks:

1. Emission Level(dBUV/m) = Raw Value(dBUV) + Correction Factor(dB/m)
2. Correction Factor(dB/m) = Antenna Factor(dB/m) + Cable Factor(dB) – Pre-Amplifier Factor(dB)
3. Margin value = Emission Level – Limit value
4. The other emission levels were very low against the limit.
5. " * " : Fundamental frequency, the limit was restricted at the RF Output Power.
6. " # " : The radiated frequency is out of the restricted band.

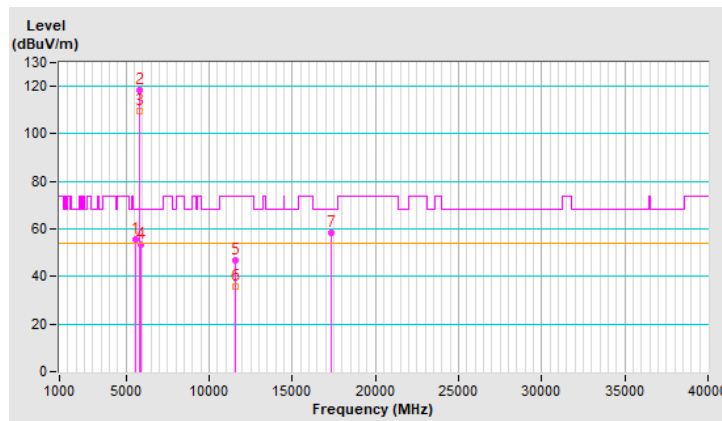

RF Mode	802.11a	Channel	CH 157 : 5785 MHz
Frequency Range	1 GHz ~ 40 GHz	Detector Function & Bandwidth	(PK) RB = 1 MHz, VB = 3 MHz (AV) RB = 1 MHz, VB = 10 Hz
Input Power	120 Vac, 60 Hz	Environmental Conditions	20°C, 70% RH
Tested By	Ryan Du		

Antenna Polarity & Test Distance : Vertical at 3 m								
No	Frequency (MHz)	Emission Level (dBuV/m)	Limit (dBuV/m)	Margin (dB)	Antenna Height (m)	Table Angle (Degree)	Raw Value (dBuV)	Correction Factor (dB/m)
1	#5644.62	67.8 PK	68.2	-0.4	1.44 V	5	63.1	4.7
2	*5785.00	125.0 PK			1.44 V	5	120.2	4.8
3	*5785.00	115.3 AV			1.44 V	5	110.5	4.8
4	#5925.32	67.7 PK	68.2	-0.5	1.44 V	5	62.6	5.1
5	11570.00	49.9 PK	74.0	-24.1	1.42 V	124	35.2	14.7
6	11570.00	38.5 AV	54.0	-15.5	1.42 V	124	23.8	14.7
7	#17355.00	60.3 PK	68.2	-7.9	1.43 V	302	41.5	18.8

Remarks:

1. Emission Level(dBuV/m) = Raw Value(dBuV) + Correction Factor(dB/m)
2. Correction Factor(dB/m) = Antenna Factor(dB/m) + Cable Factor(dB) – Pre-Amplifier Factor(dB)
3. Margin value = Emission Level – Limit value
4. The other emission levels were very low against the limit.
5. " * " : Fundamental frequency, the limit was restricted at the RF Output Power.
6. " # " : The radiated frequency is out of the restricted band.

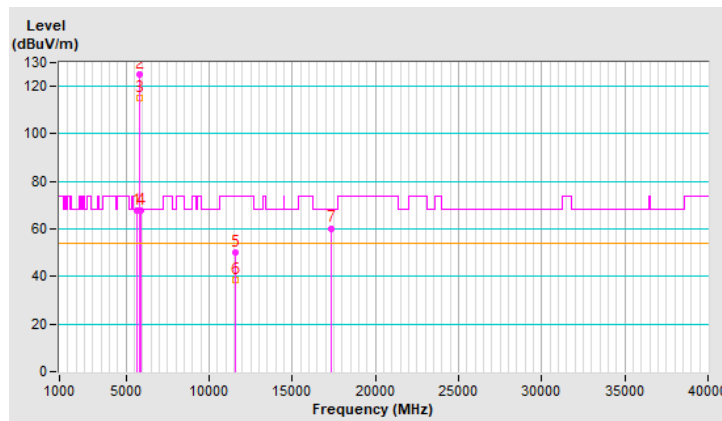

RF Mode	802.11a	Channel	CH 165 : 5825 MHz
Frequency Range	1 GHz ~ 40 GHz	Detector Function & Bandwidth	(PK) RB = 1 MHz, VB = 3 MHz (AV) RB = 1 MHz, VB = 10 Hz
Input Power	120 Vac, 60 Hz	Environmental Conditions	20°C, 70% RH
Tested By	Ryan Du		

Antenna Polarity & Test Distance : Horizontal at 3 m

No	Frequency (MHz)	Emission Level (dBUV/m)	Limit (dBUV/m)	Margin (dB)	Antenna Height (m)	Table Angle (Degree)	Raw Value (dBUV)	Correction Factor (dB/m)
1	#5627.24	55.5 PK	68.2	-12.7	1.53 H	133	50.9	4.6
2	*5825.00	118.6 PK			1.53 H	133	113.6	5.0
3	*5825.00	109.7 AV			1.53 H	133	104.7	5.0
4	#5925.83	55.5 PK	68.2	-12.7	1.53 H	133	50.4	5.1
5	11650.00	46.9 PK	74.0	-27.1	1.71 H	201	32.3	14.6
6	11650.00	36.0 AV	54.0	-18.0	1.71 H	201	21.4	14.6
7	#17475.00	58.5 PK	68.2	-9.7	1.68 H	25	39.0	19.5

Remarks:

1. Emission Level(dBUV/m) = Raw Value(dBUV) + Correction Factor(dB/m)
2. Correction Factor(dB/m) = Antenna Factor(dB/m) + Cable Factor(dB) – Pre-Amplifier Factor(dB)
3. Margin value = Emission Level – Limit value
4. The other emission levels were very low against the limit.
5. " * " : Fundamental frequency, the limit was restricted at the RF Output Power.
6. " # " : The radiated frequency is out of the restricted band.

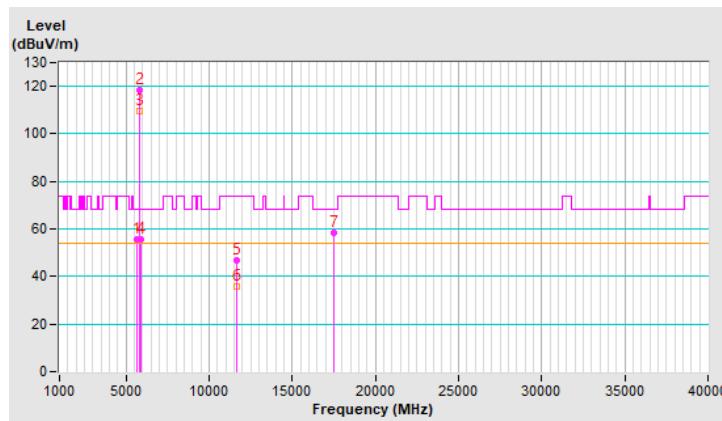

RF Mode	802.11a	Channel	CH 165 : 5825 MHz
Frequency Range	1 GHz ~ 40 GHz	Detector Function & Bandwidth	(PK) RB = 1 MHz, VB = 3 MHz (AV) RB = 1 MHz, VB = 10 Hz
Input Power	120 Vac, 60 Hz	Environmental Conditions	20°C, 70% RH
Tested By	Ryan Du		

Antenna Polarity & Test Distance : Vertical at 3 m								
No	Frequency (MHz)	Emission Level (dBuV/m)	Limit (dBuV/m)	Margin (dB)	Antenna Height (m)	Table Angle (Degree)	Raw Value (dBuV)	Correction Factor (dB/m)
1	#5644.94	61.9 PK	68.2	-6.3	1.60 V	12	57.2	4.7
2	*5825.00	124.7 PK			1.60 V	12	119.7	5.0
3	*5825.00	115.3 AV			1.60 V	12	110.3	5.0
4	#5925.15	67.8 PK	68.2	-0.4	1.60 V	12	62.7	5.1
5	11650.00	48.1 PK	74.0	-25.9	1.73 V	226	33.5	14.6
6	11650.00	37.0 AV	54.0	-17.0	1.73 V	226	22.4	14.6
7	#17475.00	59.2 PK	68.2	-9.0	1.63 V	200	39.7	19.5

Remarks:

1. Emission Level(dBuV/m) = Raw Value(dBuV) + Correction Factor(dB/m)
2. Correction Factor(dB/m) = Antenna Factor(dB/m) + Cable Factor(dB) – Pre-Amplifier Factor(dB)
3. Margin value = Emission Level – Limit value
4. The other emission levels were very low against the limit.
5. " * " : Fundamental frequency, the limit was restricted at the RF Output Power.
6. " # " : The radiated frequency is out of the restricted band.

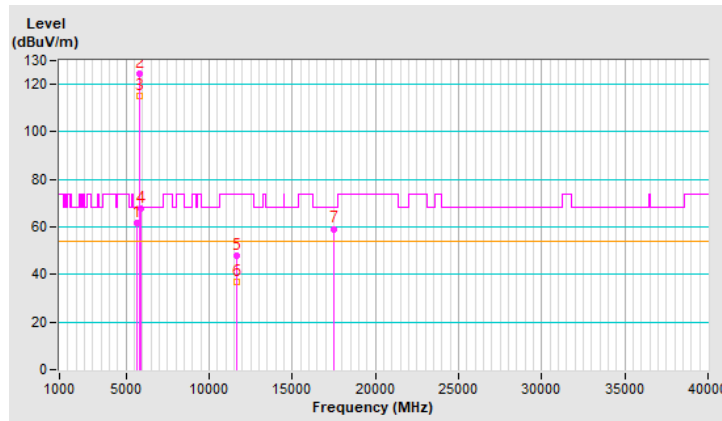

RF Mode	802.11ax (HE20)	Channel	CH 36 : 5180 MHz
Frequency Range	1 GHz ~ 40 GHz	Detector Function & Bandwidth	(PK) RB = 1 MHz, VB = 3 MHz (AV) RB = 1 MHz, VB = 10 Hz
Input Power	120 Vac, 60 Hz	Environmental Conditions	20°C, 70% RH
Tested By	Ryan Du		

Antenna Polarity & Test Distance : Horizontal at 3 m								
No	Frequency (MHz)	Emission Level (dBuV/m)	Limit (dBuV/m)	Margin (dB)	Antenna Height (m)	Table Angle (Degree)	Raw Value (dBuV)	Correction Factor (dB/m)
1	5149.24	62.1 PK	74.0	-11.9	1.51 H	136	57.6	4.5
2	5149.24	51.2 AV	54.0	-2.8	1.51 H	136	46.7	4.5
3	*5180.00	119.7 PK			1.51 H	136	115.2	4.5
4	*5180.00	108.0 AV			1.51 H	136	103.5	4.5
5	#10360.00	47.0 PK	68.2	-21.2	1.75 H	218	33.0	14.0
6	15540.00	58.5 PK	74.0	-15.5	1.62 H	44	44.5	14.0
7	15540.00	45.7 AV	54.0	-8.3	1.62 H	44	31.7	14.0

Remarks:

1. Emission Level(dBuV/m) = Raw Value(dBuV) + Correction Factor(dB/m)
2. Correction Factor(dB/m) = Antenna Factor(dB/m) + Cable Factor(dB) – Pre-Amplifier Factor(dB)
3. Margin value = Emission Level – Limit value
4. The other emission levels were very low against the limit.
5. " * " : Fundamental frequency, the limit was restricted at the RF Output Power.
6. " # " : The radiated frequency is out of the restricted band.

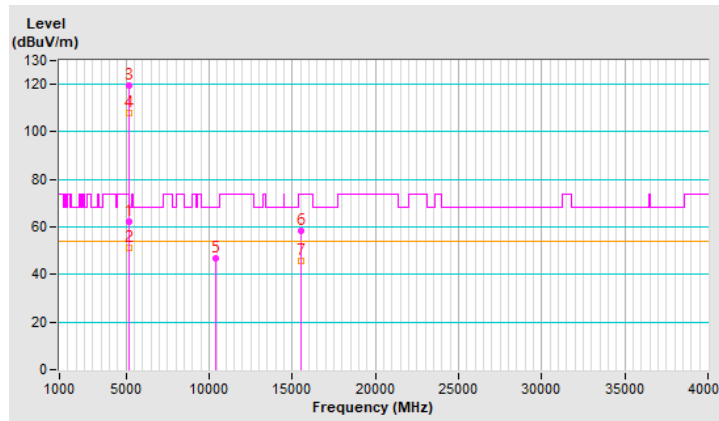

RF Mode	802.11ax (HE20)	Channel	CH 36 : 5180 MHz
Frequency Range	1 GHz ~ 40 GHz	Detector Function & Bandwidth	(PK) RB = 1 MHz, VB = 3 MHz (AV) RB = 1 MHz, VB = 10 Hz
Input Power	120 Vac, 60 Hz	Environmental Conditions	20°C, 70% RH
Tested By	Ryan Du		

Antenna Polarity & Test Distance : Vertical at 3 m								
No	Frequency (MHz)	Emission Level (dBuV/m)	Limit (dBuV/m)	Margin (dB)	Antenna Height (m)	Table Angle (Degree)	Raw Value (dBuV)	Correction Factor (dB/m)
1	5148.05	64.2 PK	74.0	-9.8	2.13 V	12	59.7	4.5
2	5148.05	53.7 AV	54.0	-0.3	2.13 V	12	49.2	4.5
3	*5180.00	121.4 PK			2.13 V	12	116.9	4.5
4	*5180.00	110.5 AV			2.13 V	12	106.0	4.5
5	#10360.00	47.8 PK	68.2	-20.4	1.75 V	200	33.8	14.0
6	15540.00	59.4 PK	74.0	-14.6	1.59 V	180	45.4	14.0
7	15540.00	47.1 AV	54.0	-6.9	1.59 V	180	33.1	14.0

Remarks:

1. Emission Level(dBuV/m) = Raw Value(dBuV) + Correction Factor(dB/m)
2. Correction Factor(dB/m) = Antenna Factor(dB/m) + Cable Factor(dB) – Pre-Amplifier Factor(dB)
3. Margin value = Emission Level – Limit value
4. The other emission levels were very low against the limit.
5. " * " : Fundamental frequency, the limit was restricted at the RF Output Power.
6. " # " : The radiated frequency is out of the restricted band.

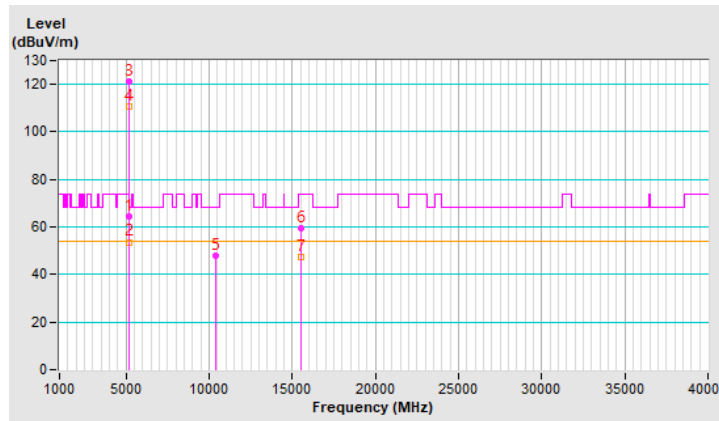

RF Mode	802.11ax (HE20)	Channel	CH 40 : 5200 MHz
Frequency Range	1 GHz ~ 40 GHz	Detector Function & Bandwidth	(PK) RB = 1 MHz, VB = 3 MHz (AV) RB = 1 MHz, VB = 10 Hz
Input Power	120 Vac, 60 Hz	Environmental Conditions	20°C, 70% RH
Tested By	Ryan Du		

Antenna Polarity & Test Distance : Horizontal at 3 m								
No	Frequency (MHz)	Emission Level (dBuV/m)	Limit (dBuV/m)	Margin (dB)	Antenna Height (m)	Table Angle (Degree)	Raw Value (dBuV)	Correction Factor (dB/m)
1	5150.00	59.2 PK	74.0	-14.8	1.57 H	140	54.7	4.5
2	5150.00	49.7 AV	54.0	-4.3	1.57 H	140	45.2	4.5
3	*5200.00	119.5 PK			1.57 H	140	115.2	4.3
4	*5200.00	109.2 AV			1.57 H	140	104.9	4.3
5	#10400.00	47.1 PK	68.2	-21.1	1.69 H	220	33.0	14.1
6	15600.00	57.8 PK	74.0	-16.2	1.62 H	50	43.5	14.3
7	15600.00	45.4 AV	54.0	-8.6	1.62 H	50	31.1	14.3

Remarks:

1. Emission Level(dBuV/m) = Raw Value(dBuV) + Correction Factor(dB/m)
2. Correction Factor(dB/m) = Antenna Factor(dB/m) + Cable Factor(dB) – Pre-Amplifier Factor(dB)
3. Margin value = Emission Level – Limit value
4. The other emission levels were very low against the limit.
5. " * ": Fundamental frequency, the limit was restricted at the RF Output Power.
6. " # ": The radiated frequency is out of the restricted band.

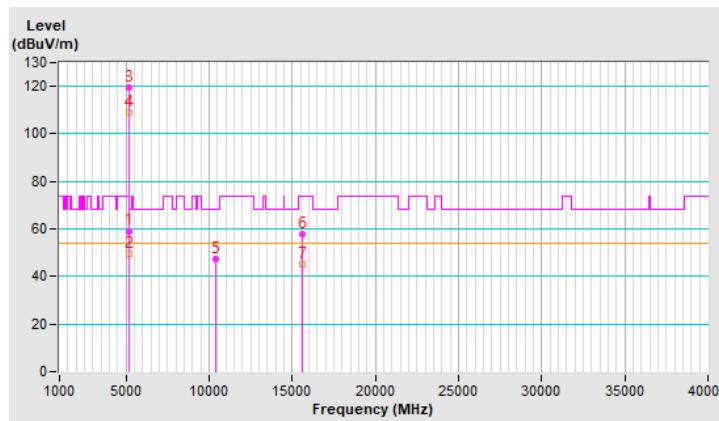

RF Mode	802.11ax (HE20)	Channel	CH 40 : 5200 MHz
Frequency Range	1 GHz ~ 40 GHz	Detector Function & Bandwidth	(PK) RB = 1 MHz, VB = 3 MHz (AV) RB = 1 MHz, VB = 10 Hz
Input Power	120 Vac, 60 Hz	Environmental Conditions	20°C, 70% RH
Tested By	Ryan Du		

Antenna Polarity & Test Distance : Vertical at 3 m								
No	Frequency (MHz)	Emission Level (dBuV/m)	Limit (dBuV/m)	Margin (dB)	Antenna Height (m)	Table Angle (Degree)	Raw Value (dBuV)	Correction Factor (dB/m)
1	5150.00	65.9 PK	74.0	-8.1	2.25 V	13	61.4	4.5
2	5150.00	53.9 AV	54.0	-0.1	2.25 V	13	49.4	4.5
3	*5200.00	123.5 PK			2.25 V	13	119.2	4.3
4	*5200.00	113.0 AV			2.25 V	13	108.7	4.3
5	#10400.00	47.4 PK	68.2	-20.8	1.80 V	218	33.3	14.1
6	15600.00	59.6 PK	74.0	-14.4	1.54 V	194	45.3	14.3
7	15600.00	47.1 AV	54.0	-6.9	1.54 V	194	32.8	14.3

Remarks:

1. Emission Level(dBuV/m) = Raw Value(dBuV) + Correction Factor(dB/m)
2. Correction Factor(dB/m) = Antenna Factor(dB/m) + Cable Factor(dB) – Pre-Amplifier Factor(dB)
3. Margin value = Emission Level – Limit value
4. The other emission levels were very low against the limit.
5. " * " : Fundamental frequency, the limit was restricted at the RF Output Power.
6. " # " : The radiated frequency is out of the restricted band.

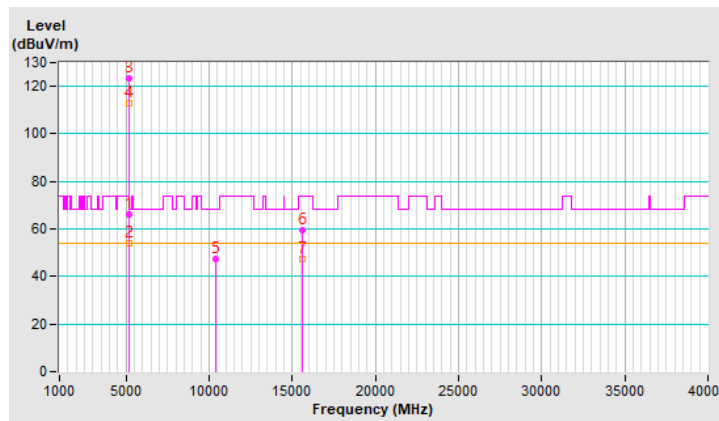

RF Mode	802.11ax (HE20)	Channel	CH 48 : 5240 MHz
Frequency Range	1 GHz ~ 40 GHz	Detector Function & Bandwidth	(PK) RB = 1 MHz, VB = 3 MHz (AV) RB = 1 MHz, VB = 10 Hz
Input Power	120 Vac, 60 Hz	Environmental Conditions	20°C, 70% RH
Tested By	Ryan Du		

Antenna Polarity & Test Distance : Horizontal at 3 m								
No	Frequency (MHz)	Emission Level (dBuV/m)	Limit (dBuV/m)	Margin (dB)	Antenna Height (m)	Table Angle (Degree)	Raw Value (dBuV)	Correction Factor (dB/m)
1	5150.00	54.3 PK	74.0	-19.7	1.51 H	148	49.8	4.5
2	5150.00	44.4 AV	54.0	-9.6	1.51 H	148	39.9	4.5
3	*5240.00	119.2 PK			1.51 H	148	115.2	4.0
4	*5240.00	108.0 AV			1.51 H	148	104.0	4.0
5	#10480.00	47.5 PK	68.2	-20.7	1.73 H	213	33.4	14.1
6	15720.00	59.2 PK	74.0	-14.8	1.65 H	20	44.8	14.4
7	15720.00	46.3 AV	54.0	-7.7	1.65 H	20	31.9	14.4

Remarks:

1. Emission Level(dBuV/m) = Raw Value(dBuV) + Correction Factor(dB/m)
2. Correction Factor(dB/m) = Antenna Factor(dB/m) + Cable Factor(dB) – Pre-Amplifier Factor(dB)
3. Margin value = Emission Level – Limit value
4. The other emission levels were very low against the limit.
5. " * ": Fundamental frequency, the limit was restricted at the RF Output Power.
6. " # ": The radiated frequency is out of the restricted band.

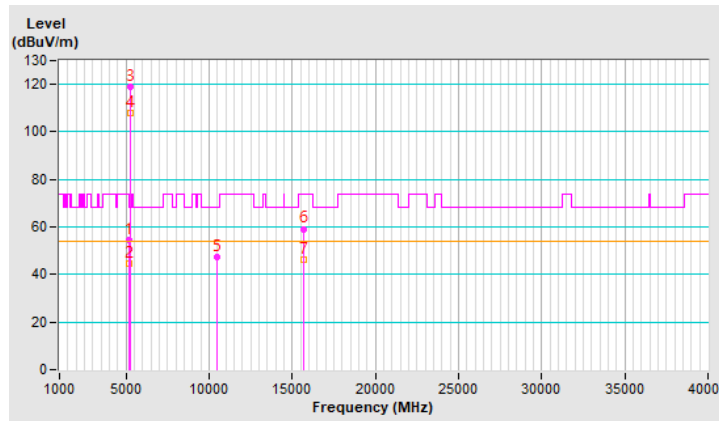

RF Mode	802.11ax (HE20)	Channel	CH 48 : 5240 MHz
Frequency Range	1 GHz ~ 40 GHz	Detector Function & Bandwidth	(PK) RB = 1 MHz, VB = 3 MHz (AV) RB = 1 MHz, VB = 10 Hz
Input Power	120 Vac, 60 Hz	Environmental Conditions	20°C, 70% RH
Tested By	Ryan Du		

Antenna Polarity & Test Distance : Vertical at 3 m								
No	Frequency (MHz)	Emission Level (dBuV/m)	Limit (dBuV/m)	Margin (dB)	Antenna Height (m)	Table Angle (Degree)	Raw Value (dBuV)	Correction Factor (dB/m)
1	5143.10	57.0 PK	74.0	-17.0	2.47 V	11	52.5	4.5
2	5143.10	47.7 AV	54.0	-6.3	2.47 V	11	43.2	4.5
3	*5240.00	123.9 PK			2.47 V	11	119.9	4.0
4	*5240.00	112.0 AV			2.47 V	11	108.0	4.0
5	#10480.00	47.6 PK	68.2	-20.6	1.79 V	217	33.5	14.1
6	15720.00	59.1 PK	74.0	-14.9	1.56 V	197	44.7	14.4
7	15720.00	46.9 AV	54.0	-7.1	1.56 V	197	32.5	14.4

Remarks:

1. Emission Level(dBuV/m) = Raw Value(dBuV) + Correction Factor(dB/m)
2. Correction Factor(dB/m) = Antenna Factor(dB/m) + Cable Factor(dB) – Pre-Amplifier Factor(dB)
3. Margin value = Emission Level – Limit value
4. The other emission levels were very low against the limit.
5. " * ": Fundamental frequency, the limit was restricted at the RF Output Power.
6. " # ": The radiated frequency is out of the restricted band.

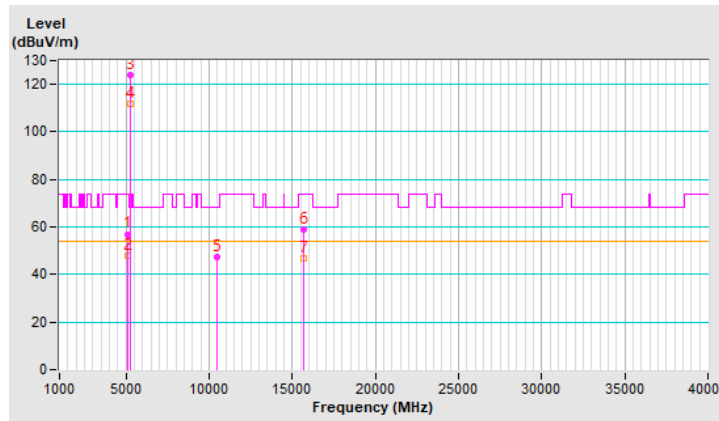

RF Mode	802.11ax (HE20)	Channel	CH 52 : 5260 MHz
Frequency Range	1 GHz ~ 40 GHz	Detector Function & Bandwidth	(PK) RB = 1 MHz, VB = 3 MHz (AV) RB = 1 MHz, VB = 10 Hz
Input Power	120 Vac, 60 Hz	Environmental Conditions	20°C, 70% RH
Tested By	Ryan Du		

Antenna Polarity & Test Distance : Horizontal at 3 m								
No	Frequency (MHz)	Emission Level (dBuV/m)	Limit (dBuV/m)	Margin (dB)	Antenna Height (m)	Table Angle (Degree)	Raw Value (dBuV)	Correction Factor (dB/m)
1	*5260.00	118.7 PK			1.47 H	134	114.7	4.0
2	*5260.00	107.5 AV			1.47 H	134	103.5	4.0
3	5350.00	54.5 PK	74.0	-19.5	1.47 H	134	50.3	4.2
4	5350.00	45.3 AV	54.0	-8.7	1.47 H	134	41.1	4.2
5	#10520.00	47.3 PK	68.2	-20.9	1.69 H	205	33.1	14.2
6	15780.00	58.8 PK	74.0	-15.2	1.64 H	49	44.3	14.5
7	15780.00	46.3 AV	54.0	-7.7	1.64 H	49	31.8	14.5

Remarks:

1. Emission Level(dBuV/m) = Raw Value(dBuV) + Correction Factor(dB/m)
2. Correction Factor(dB/m) = Antenna Factor(dB/m) + Cable Factor(dB) – Pre-Amplifier Factor(dB)
3. Margin value = Emission Level – Limit value
4. The other emission levels were very low against the limit.
5. " * " : Fundamental frequency, the limit was restricted at the RF Output Power.
6. " # " : The radiated frequency is out of the restricted band.

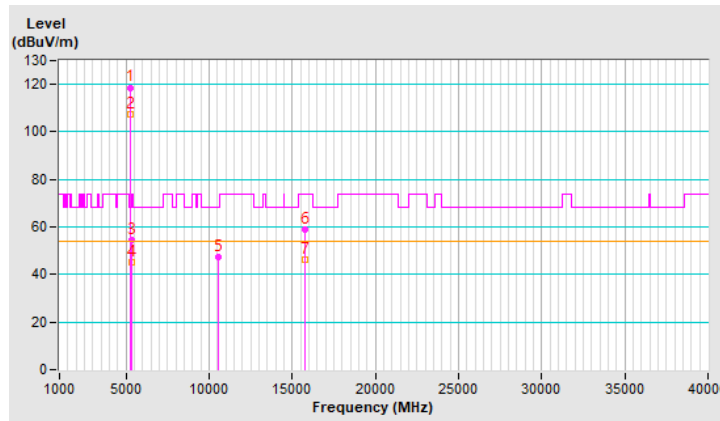

RF Mode	802.11ax (HE20)	Channel	CH 52 : 5260 MHz
Frequency Range	1 GHz ~ 40 GHz	Detector Function & Bandwidth	(PK) RB = 1 MHz, VB = 3 MHz (AV) RB = 1 MHz, VB = 10 Hz
Input Power	120 Vac, 60 Hz	Environmental Conditions	20°C, 70% RH
Tested By	Ryan Du		

Antenna Polarity & Test Distance : Vertical at 3 m								
No	Frequency (MHz)	Emission Level (dBuV/m)	Limit (dBuV/m)	Margin (dB)	Antenna Height (m)	Table Angle (Degree)	Raw Value (dBuV)	Correction Factor (dB/m)
1	*5260.00	124.4 PK			2.30 V	13	120.4	4.0
2	*5260.00	112.5 AV			2.30 V	13	108.5	4.0
3	5357.54	58.4 PK	74.0	-15.6	2.30 V	13	54.2	4.2
4	5357.54	49.3 AV	54.0	-4.7	2.30 V	13	45.1	4.2
5	#10520.00	48.1 PK	68.2	-20.1	1.77 V	207	33.9	14.2
6	15780.00	59.6 PK	74.0	-14.4	1.59 V	187	45.1	14.5
7	15780.00	47.1 AV	54.0	-6.9	1.59 V	187	32.6	14.5

Remarks:

1. Emission Level(dBuV/m) = Raw Value(dBuV) + Correction Factor(dB/m)
2. Correction Factor(dB/m) = Antenna Factor(dB/m) + Cable Factor(dB) – Pre-Amplifier Factor(dB)
3. Margin value = Emission Level – Limit value
4. The other emission levels were very low against the limit.
5. " * " : Fundamental frequency, the limit was restricted at the RF Output Power.
6. " # " : The radiated frequency is out of the restricted band.

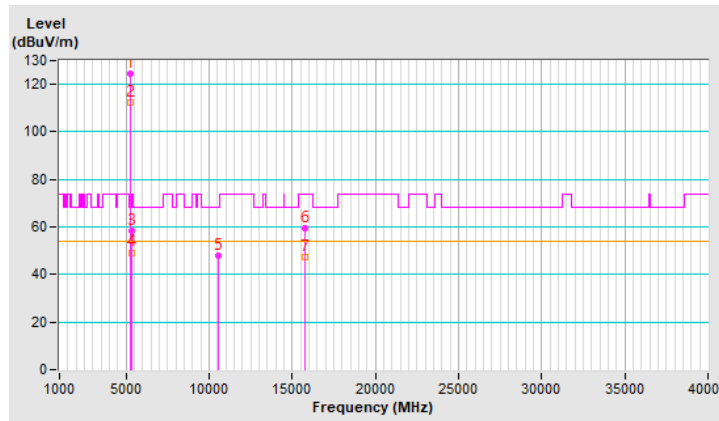

RF Mode	802.11ax (HE20)	Channel	CH 60 : 5300 MHz
Frequency Range	1 GHz ~ 40 GHz	Detector Function & Bandwidth	(PK) RB = 1 MHz, VB = 3 MHz (AV) RB = 1 MHz, VB = 10 Hz
Input Power	120 Vac, 60 Hz	Environmental Conditions	20°C, 70% RH
Tested By	Ryan Du		

Antenna Polarity & Test Distance : Horizontal at 3 m								
No	Frequency (MHz)	Emission Level (dBuV/m)	Limit (dBuV/m)	Margin (dB)	Antenna Height (m)	Table Angle (Degree)	Raw Value (dBuV)	Correction Factor (dB/m)
1	*5300.00	119.2 PK			1.51 H	163	115.2	4.0
2	*5300.00	108.1 AV			1.51 H	163	104.1	4.0
3	10600.00	47.7 PK	74.0	-26.3	1.74 H	222	34.1	13.6
4	10600.00	36.6 AV	54.0	-17.4	1.74 H	222	23.0	13.6
5	15900.00	58.7 PK	74.0	-15.3	1.63 H	23	44.3	14.4
6	15900.00	45.8 AV	54.0	-8.2	1.63 H	23	31.4	14.4

Remarks:

1. Emission Level(dBuV/m) = Raw Value(dBuV) + Correction Factor(dB/m)
2. Correction Factor(dB/m) = Antenna Factor(dB/m) + Cable Factor(dB) – Pre-Amplifier Factor(dB)
3. Margin value = Emission Level – Limit value
4. The other emission levels were very low against the limit.
5. " * " : Fundamental frequency, the limit was restricted at the RF Output Power.

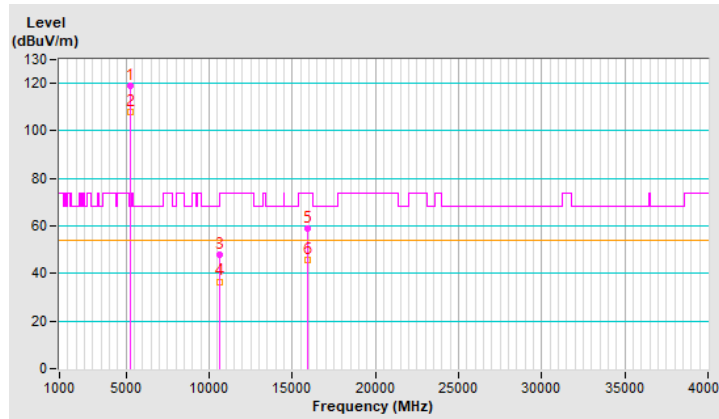

RF Mode	802.11ax (HE20)	Channel	CH 60 : 5300 MHz
Frequency Range	1 GHz ~ 40 GHz	Detector Function & Bandwidth	(PK) RB = 1 MHz, VB = 3 MHz (AV) RB = 1 MHz, VB = 10 Hz
Input Power	120 Vac, 60 Hz	Environmental Conditions	20°C, 70% RH
Tested By	Ryan Du		

Antenna Polarity & Test Distance : Vertical at 3 m								
No	Frequency (MHz)	Emission Level (dBuV/m)	Limit (dBuV/m)	Margin (dB)	Antenna Height (m)	Table Angle (Degree)	Raw Value (dBuV)	Correction Factor (dB/m)
1	*5300.00	123.4 PK			2.04 V	15	119.4	4.0
2	*5300.00	112.3 AV			2.04 V	15	108.3	4.0
3	10600.00	47.8 PK	74.0	-26.2	1.81 V	215	34.2	13.6
4	10600.00	36.7 AV	54.0	-17.3	1.81 V	215	23.1	13.6
5	15900.00	59.3 PK	74.0	-14.7	1.64 V	188	44.9	14.4
6	15900.00	47.1 AV	54.0	-6.9	1.64 V	188	32.7	14.4

Remarks:

1. Emission Level(dBuV/m) = Raw Value(dBuV) + Correction Factor(dB/m)
2. Correction Factor(dB/m) = Antenna Factor(dB/m) + Cable Factor(dB) – Pre-Amplifier Factor(dB)
3. Margin value = Emission Level – Limit value
4. The other emission levels were very low against the limit.
5. " * " : Fundamental frequency, the limit was restricted at the RF Output Power.

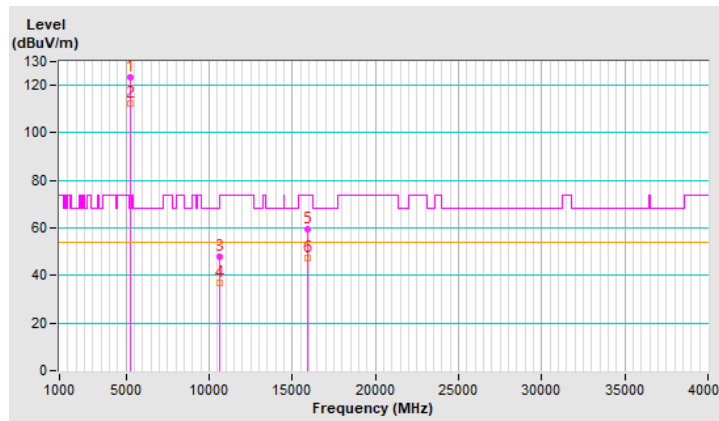

RF Mode	802.11ax (HE20)	Channel	CH 64 : 5320 MHz
Frequency Range	1 GHz ~ 40 GHz	Detector Function & Bandwidth	(PK) RB = 1 MHz, VB = 3 MHz (AV) RB = 1 MHz, VB = 10 Hz
Input Power	120 Vac, 60 Hz	Environmental Conditions	20°C, 70% RH
Tested By	Ryan Du		

Antenna Polarity & Test Distance : Horizontal at 3 m

No	Frequency (MHz)	Emission Level (dBuV/m)	Limit (dBuV/m)	Margin (dB)	Antenna Height (m)	Table Angle (Degree)	Raw Value (dBuV)	Correction Factor (dB/m)
1	*5320.00	117.6 PK			1.46 H	146	113.5	4.1
2	*5320.00	106.2 AV			1.46 H	146	102.1	4.1
3	5351.76	56.5 PK	74.0	-17.5	1.46 H	146	52.3	4.2
4	5351.76	47.1 AV	54.0	-6.9	1.46 H	146	42.9	4.2
5	10640.00	47.5 PK	74.0	-26.5	1.76 H	229	33.8	13.7
6	10640.00	36.3 AV	54.0	-17.7	1.76 H	229	22.6	13.7
7	15960.00	58.6 PK	74.0	-15.4	1.66 H	46	43.7	14.9
8	15960.00	45.9 AV	54.0	-8.1	1.66 H	46	31.0	14.9

Remarks:

1. Emission Level(dBuV/m) = Raw Value(dBuV) + Correction Factor(dB/m)
2. Correction Factor(dB/m) = Antenna Factor(dB/m) + Cable Factor(dB) – Pre-Amplifier Factor(dB)
3. Margin value = Emission Level – Limit value
4. The other emission levels were very low against the limit.
5. " * " : Fundamental frequency, the limit was restricted at the RF Output Power.

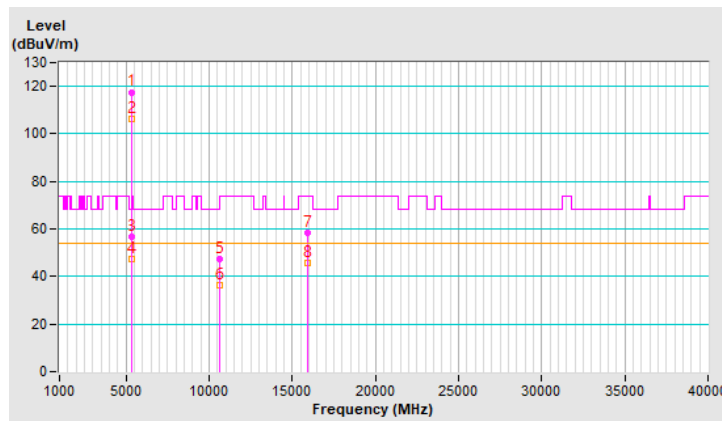

RF Mode	802.11ax (HE20)	Channel	CH 64 : 5320 MHz
Frequency Range	1 GHz ~ 40 GHz	Detector Function & Bandwidth	(PK) RB = 1 MHz, VB = 3 MHz (AV) RB = 1 MHz, VB = 10 Hz
Input Power	120 Vac, 60 Hz	Environmental Conditions	20°C, 70% RH
Tested By	Ryan Du		

Antenna Polarity & Test Distance : Vertical at 3 m								
No	Frequency (MHz)	Emission Level (dBuV/m)	Limit (dBuV/m)	Margin (dB)	Antenna Height (m)	Table Angle (Degree)	Raw Value (dBuV)	Correction Factor (dB/m)
1	*5320.00	121.9 PK			1.65 V	22	117.8	4.1
2	*5320.00	110.3 AV			1.65 V	22	106.2	4.1
3	5352.12	64.1 PK	74.0	-9.9	1.65 V	22	59.9	4.2
4	5352.12	53.8 AV	54.0	-0.2	1.65 V	22	49.6	4.2
5	10640.00	48.1 PK	74.0	-25.9	1.83 V	219	34.4	13.7
6	10640.00	36.8 AV	54.0	-17.2	1.83 V	219	23.1	13.7
7	15960.00	59.3 PK	74.0	-14.7	1.57 V	180	44.4	14.9
8	15960.00	47.1 AV	54.0	-6.9	1.57 V	180	32.2	14.9

Remarks:

1. Emission Level(dBuV/m) = Raw Value(dBuV) + Correction Factor(dB/m)
2. Correction Factor(dB/m) = Antenna Factor(dB/m) + Cable Factor(dB) – Pre-Amplifier Factor(dB)
3. Margin value = Emission Level – Limit value
4. The other emission levels were very low against the limit.
5. " * " : Fundamental frequency, the limit was restricted at the RF Output Power.

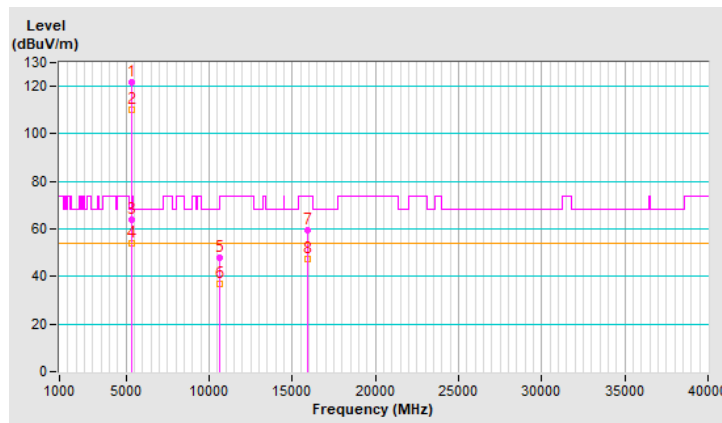

RF Mode	802.11ax (HE20)	Channel	CH 100 : 5500 MHz
Frequency Range	1 GHz ~ 40 GHz	Detector Function & Bandwidth	(PK) RB = 1 MHz, VB = 3 MHz (AV) RB = 1 MHz, VB = 10 Hz
Input Power	120 Vac, 60 Hz	Environmental Conditions	20°C, 70% RH
Tested By	Ryan Du		

Antenna Polarity & Test Distance : Horizontal at 3 m								
No	Frequency (MHz)	Emission Level (dBuV/m)	Limit (dBuV/m)	Margin (dB)	Antenna Height (m)	Table Angle (Degree)	Raw Value (dBuV)	Correction Factor (dB/m)
1	5460.00	62.0 PK	74.0	-12.0	1.49 H	154	57.6	4.4
2	5460.00	49.1 AV	54.0	-4.9	1.49 H	154	44.7	4.4
3	#5470.00	65.6 PK	68.2	-2.6	1.49 H	154	61.2	4.4
4	*5500.00	119.2 PK			1.49 H	154	114.7	4.5
5	*5500.00	107.8 AV			1.49 H	154	103.3	4.5
6	11000.00	47.6 PK	74.0	-26.4	1.70 H	211	33.0	14.6
7	11000.00	36.4 AV	54.0	-17.6	1.70 H	211	21.8	14.6
8	#16500.00	57.7 PK	68.2	-10.5	1.62 H	47	40.9	16.8

Remarks:

1. Emission Level(dBuV/m) = Raw Value(dBuV) + Correction Factor(dB/m)
2. Correction Factor(dB/m) = Antenna Factor(dB/m) + Cable Factor(dB) – Pre-Amplifier Factor(dB)
3. Margin value = Emission Level – Limit value
4. The other emission levels were very low against the limit.
5. " * " : Fundamental frequency, the limit was restricted at the RF Output Power.
6. " # " : The radiated frequency is out of the restricted band.

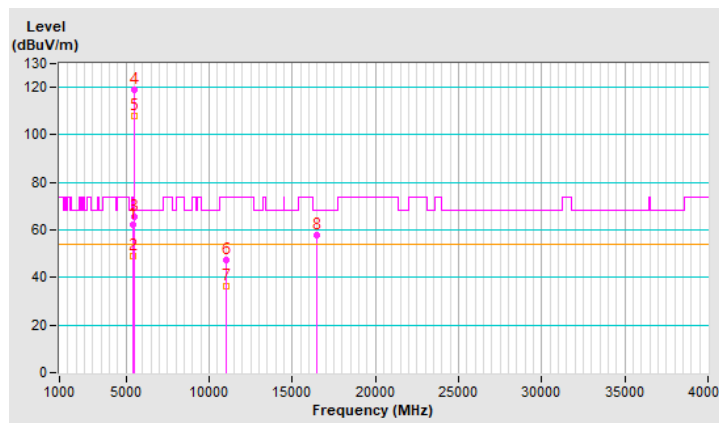

RF Mode	802.11ax (HE20)	Channel	CH 100 : 5500 MHz
Frequency Range	1 GHz ~ 40 GHz	Detector Function & Bandwidth	(PK) RB = 1 MHz, VB = 3 MHz (AV) RB = 1 MHz, VB = 10 Hz
Input Power	120 Vac, 60 Hz	Environmental Conditions	20°C, 70% RH
Tested By	Ryan Du		

Antenna Polarity & Test Distance : Vertical at 3 m								
No	Frequency (MHz)	Emission Level (dBuV/m)	Limit (dBuV/m)	Margin (dB)	Antenna Height (m)	Table Angle (Degree)	Raw Value (dBuV)	Correction Factor (dB/m)
1	5460.00	65.1 PK	74.0	-8.9	1.86 V	12	60.7	4.4
2	5460.00	53.7 AV	54.0	-0.3	1.86 V	12	49.3	4.4
3	#5470.00	67.8 PK	68.2	-0.4	1.86 V	12	63.4	4.4
4	*5500.00	124.4 PK			1.86 V	12	119.9	4.5
5	*5500.00	112.4 AV			1.86 V	12	107.9	4.5
6	11000.00	47.9 PK	74.0	-26.1	1.75 V	200	33.3	14.6
7	11000.00	36.4 AV	54.0	-17.6	1.75 V	200	21.8	14.6
8	#16500.00	59.9 PK	68.2	-8.3	1.61 V	203	43.1	16.8

Remarks:

1. Emission Level(dBuV/m) = Raw Value(dBuV) + Correction Factor(dB/m)
2. Correction Factor(dB/m) = Antenna Factor(dB/m) + Cable Factor(dB) – Pre-Amplifier Factor(dB)
3. Margin value = Emission Level – Limit value
4. The other emission levels were very low against the limit.
5. " * " : Fundamental frequency, the limit was restricted at the RF Output Power.
6. " # " : The radiated frequency is out of the restricted band.

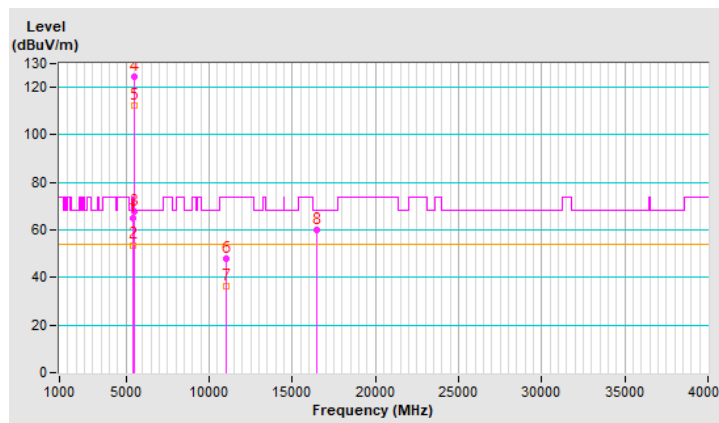

RF Mode	802.11ax (HE20)	Channel	CH 116 : 5580 MHz
Frequency Range	1 GHz ~ 40 GHz	Detector Function & Bandwidth	(PK) RB = 1 MHz, VB = 3 MHz (AV) RB = 1 MHz, VB = 10 Hz
Input Power	120 Vac, 60 Hz	Environmental Conditions	20°C, 70% RH
Tested By	Ryan Du		

Antenna Polarity & Test Distance : Horizontal at 3 m

No	Frequency (MHz)	Emission Level (dBuV/m)	Limit (dBuV/m)	Margin (dB)	Antenna Height (m)	Table Angle (Degree)	Raw Value (dBuV)	Correction Factor (dB/m)
1	*5580.00	118.8 PK			1.50 H	154	114.4	4.4
2	*5580.00	107.3 AV			1.50 H	154	102.9	4.4
3	11160.00	47.4 PK	74.0	-26.6	1.76 H	217	33.4	14.0
4	11160.00	36.4 AV	54.0	-17.6	1.76 H	217	22.4	14.0
5	#16740.00	58.4 PK	68.2	-9.8	1.64 H	48	40.1	18.3

Remarks:

1. Emission Level(dBuV/m) = Raw Value(dBuV) + Correction Factor(dB/m)
2. Correction Factor(dB/m) = Antenna Factor(dB/m) + Cable Factor(dB) – Pre-Amplifier Factor(dB)
3. Margin value = Emission Level – Limit value
4. The other emission levels were very low against the limit.
5. " * " : Fundamental frequency, the limit was restricted at the RF Output Power.
6. " # " : The radiated frequency is out of the restricted band.

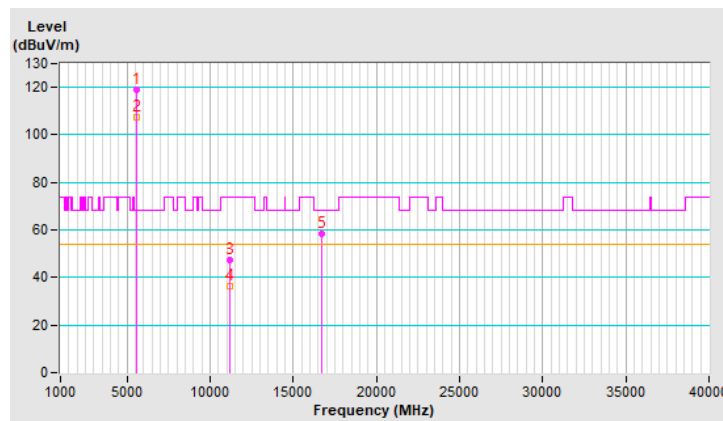

RF Mode	802.11ax (HE20)	Channel	CH 116 : 5580 MHz
Frequency Range	1 GHz ~ 40 GHz	Detector Function & Bandwidth	(PK) RB = 1 MHz, VB = 3 MHz (AV) RB = 1 MHz, VB = 10 Hz
Input Power	120 Vac, 60 Hz	Environmental Conditions	20°C, 70% RH
Tested By	Ryan Du		

Antenna Polarity & Test Distance : Vertical at 3 m

No	Frequency (MHz)	Emission Level (dBuV/m)	Limit (dBuV/m)	Margin (dB)	Antenna Height (m)	Table Angle (Degree)	Raw Value (dBuV)	Correction Factor (dB/m)
1	*5580.00	124.2 PK			1.67 V	24	119.8	4.4
2	*5580.00	112.0 AV			1.67 V	24	107.6	4.4
3	11160.00	47.8 PK	74.0	-26.2	1.74 V	216	33.8	14.0
4	11160.00	36.8 AV	54.0	-17.2	1.74 V	216	22.8	14.0
5	#16740.00	59.8 PK	68.2	-8.4	1.55 V	206	41.5	18.3

Remarks:

1. Emission Level(dBuV/m) = Raw Value(dBuV) + Correction Factor(dB/m)
2. Correction Factor(dB/m) = Antenna Factor(dB/m) + Cable Factor(dB) – Pre-Amplifier Factor(dB)
3. Margin value = Emission Level – Limit value
4. The other emission levels were very low against the limit.
5. " * " : Fundamental frequency, the limit was restricted at the RF Output Power.
6. " # " : The radiated frequency is out of the restricted band.

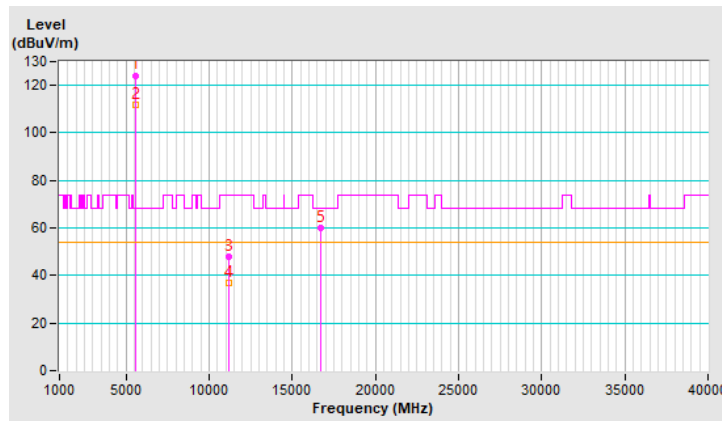

RF Mode	802.11ax (HE20)	Channel	CH 140 : 5700 MHz
Frequency Range	1 GHz ~ 40 GHz	Detector Function & Bandwidth	(PK) RB = 1 MHz, VB = 3 MHz (AV) RB = 1 MHz, VB = 10 Hz
Input Power	120 Vac, 60 Hz	Environmental Conditions	20°C, 70% RH
Tested By	Ryan Du		

Antenna Polarity & Test Distance : Horizontal at 3 m

No	Frequency (MHz)	Emission Level (dBuV/m)	Limit (dBuV/m)	Margin (dB)	Antenna Height (m)	Table Angle (Degree)	Raw Value (dBuV)	Correction Factor (dB/m)
1	*5700.00	119.2 PK			1.54 H	157	114.7	4.5
2	*5700.00	108.0 AV			1.54 H	157	103.5	4.5
3	#5725.00	64.0 PK	68.2	-4.2	1.54 H	157	59.4	4.6
4	11400.00	47.6 PK	74.0	-26.4	1.73 H	218	32.6	15.0
5	11400.00	36.9 AV	54.0	-17.1	1.73 H	218	21.9	15.0
6	#17100.00	59.1 PK	68.2	-9.1	1.64 H	30	39.8	19.3

Remarks:

1. Emission Level(dBuV/m) = Raw Value(dBuV) + Correction Factor(dB/m)
2. Correction Factor(dB/m) = Antenna Factor(dB/m) + Cable Factor(dB) – Pre-Amplifier Factor(dB)
3. Margin value = Emission Level – Limit value
4. The other emission levels were very low against the limit.
5. " * " : Fundamental frequency, the limit was restricted at the RF Output Power.
6. " # " : The radiated frequency is out of the restricted band.

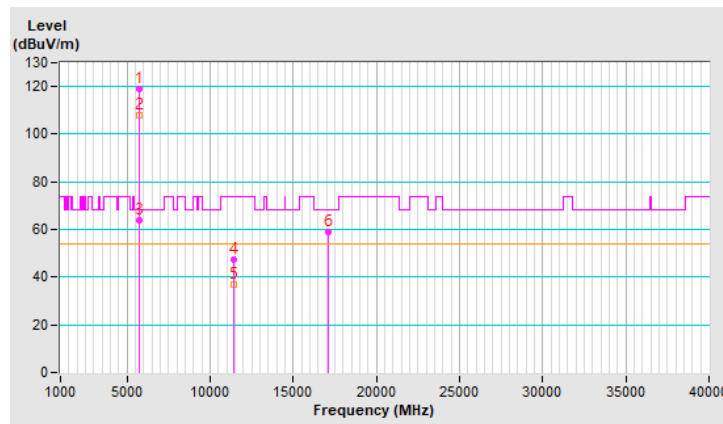

RF Mode	802.11ax (HE20)	Channel	CH 140 : 5700 MHz
Frequency Range	1 GHz ~ 40 GHz	Detector Function & Bandwidth	(PK) RB = 1 MHz, VB = 3 MHz (AV) RB = 1 MHz, VB = 10 Hz
Input Power	120 Vac, 60 Hz	Environmental Conditions	20°C, 70% RH
Tested By	Ryan Du		

Antenna Polarity & Test Distance : Vertical at 3 m

No	Frequency (MHz)	Emission Level (dBuV/m)	Limit (dBuV/m)	Margin (dB)	Antenna Height (m)	Table Angle (Degree)	Raw Value (dBuV)	Correction Factor (dB/m)
1	*5700.00	118.0 PK			1.41 V	15	113.5	4.5
2	*5700.00	106.5 AV			1.41 V	15	102.0	4.5
3	#5726.11	67.8 PK	68.2	-0.4	1.41 V	15	63.2	4.6
4	11400.00	48.4 PK	74.0	-25.6	1.78 V	217	33.4	15.0
5	11400.00	37.0 AV	54.0	-17.0	1.78 V	217	22.0	15.0
6	#17100.00	59.6 PK	68.2	-8.6	1.60 V	186	40.3	19.3

Remarks:

1. Emission Level(dBuV/m) = Raw Value(dBuV) + Correction Factor(dB/m)
2. Correction Factor(dB/m) = Antenna Factor(dB/m) + Cable Factor(dB) – Pre-Amplifier Factor(dB)
3. Margin value = Emission Level – Limit value
4. The other emission levels were very low against the limit.
5. " * " : Fundamental frequency, the limit was restricted at the RF Output Power.
6. " # " : The radiated frequency is out of the restricted band.

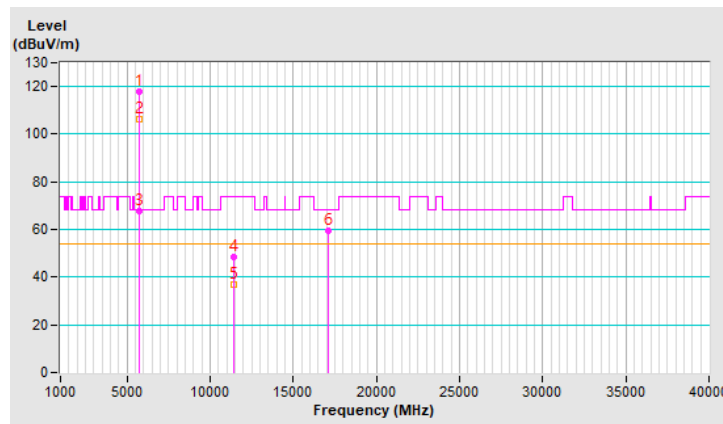

RF Mode	802.11ax (HE20)	Channel	CH 144 : 5720 MHz
Frequency Range	1 GHz ~ 40 GHz	Detector Function & Bandwidth	(PK) RB = 1 MHz, VB = 3 MHz (AV) RB = 1 MHz, VB = 10 Hz
Input Power	120 Vac, 60 Hz	Environmental Conditions	20°C, 70% RH
Tested By	Ryan Du		

Antenna Polarity & Test Distance : Horizontal at 3 m

No	Frequency (MHz)	Emission Level (dBuV/m)	Limit (dBuV/m)	Margin (dB)	Antenna Height (m)	Table Angle (Degree)	Raw Value (dBuV)	Correction Factor (dB/m)
1	*5720.00	119.1 PK			1.57 H	150	114.5	4.6
2	*5720.00	108.0 AV			1.57 H	150	103.4	4.6
3	11440.00	47.4 PK	74.0	-26.6	1.69 H	221	32.5	14.9
4	11440.00	36.4 AV	54.0	-17.6	1.69 H	221	21.5	14.9
5	#17160.00	57.9 PK	68.2	-10.3	1.58 H	33	38.8	19.1

Remarks:

1. Emission Level(dBuV/m) = Raw Value(dBuV) + Correction Factor(dB/m)
2. Correction Factor(dB/m) = Antenna Factor(dB/m) + Cable Factor(dB) – Pre-Amplifier Factor(dB)
3. Margin value = Emission Level – Limit value
4. The other emission levels were very low against the limit.
5. " * " : Fundamental frequency, the limit was restricted at the RF Output Power.
6. " # " : The radiated frequency is out of the restricted band.

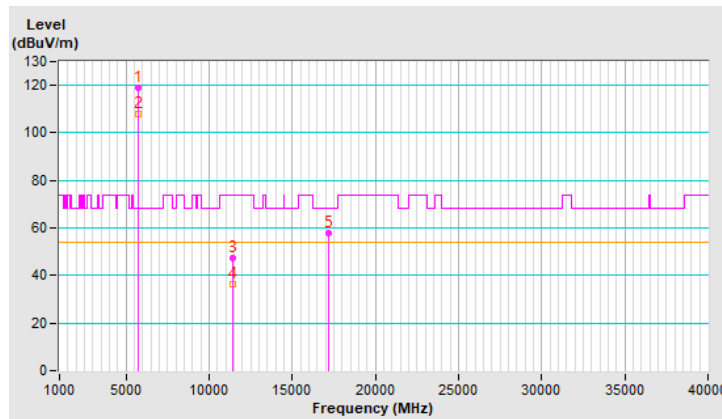

RF Mode	802.11ax (HE20)	Channel	CH 144 : 5720 MHz
Frequency Range	1 GHz ~ 40 GHz	Detector Function & Bandwidth	(PK) RB = 1 MHz, VB = 3 MHz (AV) RB = 1 MHz, VB = 10 Hz
Input Power	120 Vac, 60 Hz	Environmental Conditions	20°C, 70% RH
Tested By	Ryan Du		

Antenna Polarity & Test Distance : Vertical at 3 m

No	Frequency (MHz)	Emission Level (dBuV/m)	Limit (dBuV/m)	Margin (dB)	Antenna Height (m)	Table Angle (Degree)	Raw Value (dBuV)	Correction Factor (dB/m)
1	*5720.00	124.1 PK			1.51 V	32	119.5	4.6
2	*5720.00	112.2 AV			1.51 V	32	107.6	4.6
3	11440.00	47.8 PK	74.0	-26.2	1.77 V	202	32.9	14.9
4	11440.00	36.2 AV	54.0	-17.8	1.77 V	202	21.3	14.9
5	#17160.00	59.8 PK	68.2	-8.4	1.61 V	186	40.7	19.1

Remarks:

1. Emission Level(dBuV/m) = Raw Value(dBuV) + Correction Factor(dB/m)
2. Correction Factor(dB/m) = Antenna Factor(dB/m) + Cable Factor(dB) – Pre-Amplifier Factor(dB)
3. Margin value = Emission Level – Limit value
4. The other emission levels were very low against the limit.
5. " * " : Fundamental frequency, the limit was restricted at the RF Output Power.
6. " # " : The radiated frequency is out of the restricted band.

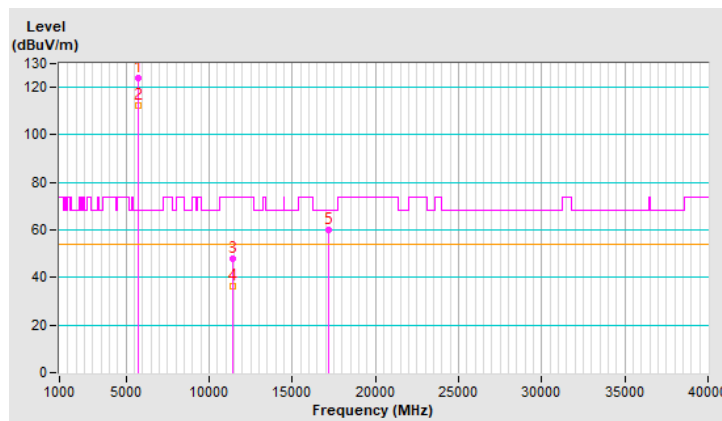

RF Mode	802.11ax (HE20)	Channel	CH 149 : 5745 MHz
Frequency Range	1 GHz ~ 40 GHz	Detector Function & Bandwidth	(PK) RB = 1 MHz, VB = 3 MHz (AV) RB = 1 MHz, VB = 10 Hz
Input Power	120 Vac, 60 Hz	Environmental Conditions	20°C, 70% RH
Tested By	Ryan Du		

Antenna Polarity & Test Distance : Horizontal at 3 m

No	Frequency (MHz)	Emission Level (dBUV/m)	Limit (dBUV/m)	Margin (dB)	Antenna Height (m)	Table Angle (Degree)	Raw Value (dBUV)	Correction Factor (dB/m)
1	#5643.77	58.7 PK	68.2	-9.5	1.50 H	140	54.0	4.7
2	*5745.00	120.1 PK			1.50 H	140	115.5	4.6
3	*5745.00	108.5 AV			1.50 H	140	103.9	4.6
4	#5950.64	52.3 PK	68.2	-15.9	1.50 H	140	47.2	5.1
5	11490.00	47.3 PK	74.0	-26.7	1.66 H	225	32.4	14.9
6	11490.00	36.2 AV	54.0	-17.8	1.66 H	225	21.3	14.9
7	#17235.00	58.8 PK	68.2	-9.4	1.67 H	20	40.0	18.8

Remarks:

1. Emission Level(dBUV/m) = Raw Value(dBUV) + Correction Factor(dB/m)
2. Correction Factor(dB/m) = Antenna Factor(dB/m) + Cable Factor(dB) – Pre-Amplifier Factor(dB)
3. Margin value = Emission Level – Limit value
4. The other emission levels were very low against the limit.
5. " * " : Fundamental frequency, the limit was restricted at the RF Output Power.
6. " # " : The radiated frequency is out of the restricted band.

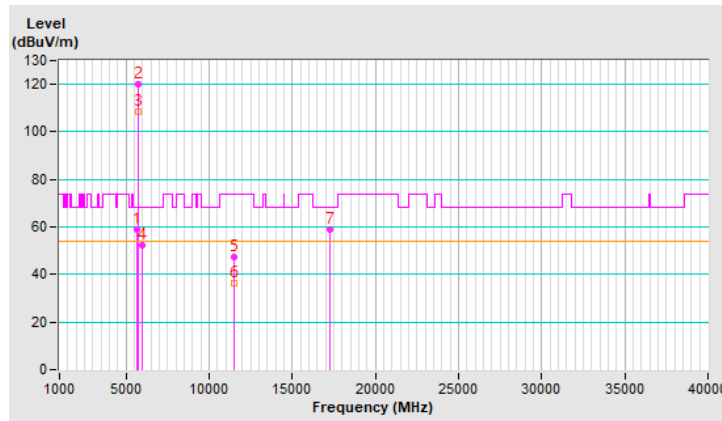

RF Mode	802.11ax (HE20)	Channel	CH 149 : 5745 MHz
Frequency Range	1 GHz ~ 40 GHz	Detector Function & Bandwidth	(PK) RB = 1 MHz, VB = 3 MHz (AV) RB = 1 MHz, VB = 10 Hz
Input Power	120 Vac, 60 Hz	Environmental Conditions	20°C, 70% RH
Tested By	Ryan Du		

Antenna Polarity & Test Distance : Vertical at 3 m

No	Frequency (MHz)	Emission Level (dBuV/m)	Limit (dBuV/m)	Margin (dB)	Antenna Height (m)	Table Angle (Degree)	Raw Value (dBuV)	Correction Factor (dB/m)
1	#5645.33	67.8 PK	68.2	-0.4	1.56 V	16	63.1	4.7
2	*5745.00	126.3 PK			1.56 V	16	121.7	4.6
3	*5745.00	114.5 AV			1.56 V	16	109.9	4.6
4	#5931.25	53.4 PK	68.2	-14.8	1.56 V	16	48.3	5.1
5	11490.00	47.3 PK	74.0	-26.7	1.78 V	203	32.4	14.9
6	11490.00	36.1 AV	54.0	-17.9	1.78 V	203	21.2	14.9
7	#17235.00	59.3 PK	68.2	-8.9	1.63 V	203	40.5	18.8

Remarks:

1. Emission Level(dBuV/m) = Raw Value(dBuV) + Correction Factor(dB/m)
2. Correction Factor(dB/m) = Antenna Factor(dB/m) + Cable Factor(dB) – Pre-Amplifier Factor(dB)
3. Margin value = Emission Level – Limit value
4. The other emission levels were very low against the limit.
5. " * " : Fundamental frequency, the limit was restricted at the RF Output Power.
6. " # " : The radiated frequency is out of the restricted band.

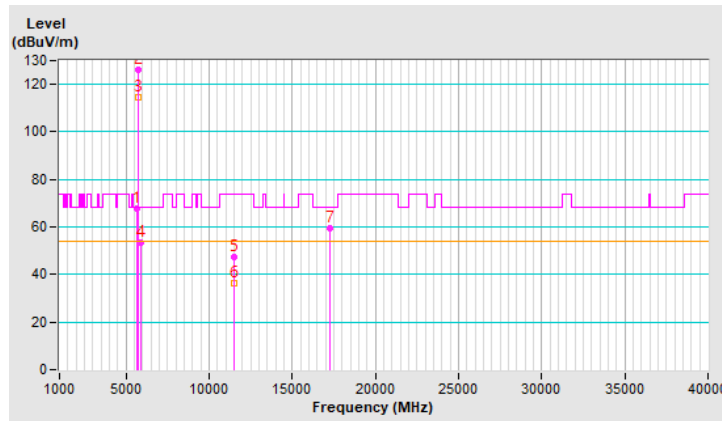

RF Mode	802.11ax (HE20)	Channel	CH 157 : 5785 MHz
Frequency Range	1 GHz ~ 40 GHz	Detector Function & Bandwidth	(PK) RB = 1 MHz, VB = 3 MHz (AV) RB = 1 MHz, VB = 10 Hz
Input Power	120 Vac, 60 Hz	Environmental Conditions	20°C, 70% RH
Tested By	Ryan Du		

Antenna Polarity & Test Distance : Horizontal at 3 m

No	Frequency (MHz)	Emission Level (dBuV/m)	Limit (dBuV/m)	Margin (dB)	Antenna Height (m)	Table Angle (Degree)	Raw Value (dBuV)	Correction Factor (dB/m)
1	#5610.03	54.8 PK	68.2	-13.4	1.45 H	145	50.3	4.5
2	*5785.00	120.1 PK			1.45 H	145	115.3	4.8
3	*5785.00	108.8 AV			1.45 H	145	104.0	4.8
4	#5927.55	53.0 PK	68.2	-15.2	1.45 H	145	47.9	5.1
5	11570.00	47.4 PK	74.0	-26.6	1.76 H	214	32.7	14.7
6	11570.00	36.6 AV	54.0	-17.4	1.76 H	214	21.9	14.7
7	#17355.00	57.9 PK	68.2	-10.3	1.68 H	39	39.1	18.8

Remarks:

1. Emission Level(dBuV/m) = Raw Value(dBuV) + Correction Factor(dB/m)
2. Correction Factor(dB/m) = Antenna Factor(dB/m) + Cable Factor(dB) – Pre-Amplifier Factor(dB)
3. Margin value = Emission Level – Limit value
4. The other emission levels were very low against the limit.
5. " * " : Fundamental frequency, the limit was restricted at the RF Output Power.
6. " # " : The radiated frequency is out of the restricted band.

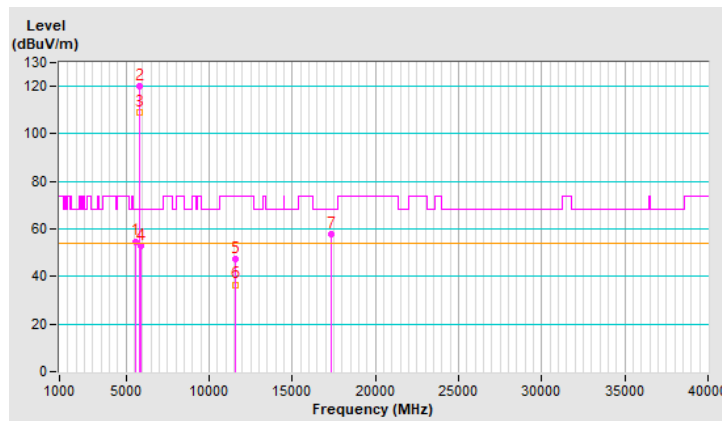

RF Mode	802.11ax (HE20)	Channel	CH 157 : 5785 MHz
Frequency Range	1 GHz ~ 40 GHz	Detector Function & Bandwidth	(PK) RB = 1 MHz, VB = 3 MHz (AV) RB = 1 MHz, VB = 10 Hz
Input Power	120 Vac, 60 Hz	Environmental Conditions	20°C, 70% RH
Tested By	Ryan Du		

Antenna Polarity & Test Distance : Vertical at 3 m								
No	Frequency (MHz)	Emission Level (dBuV/m)	Limit (dBuV/m)	Margin (dB)	Antenna Height (m)	Table Angle (Degree)	Raw Value (dBuV)	Correction Factor (dB/m)
1	#5644.38	68.1 PK	68.2	-0.1	1.49 V	8	63.4	4.7
2	*5785.00	125.7 PK			1.49 V	8	120.9	4.8
3	*5785.00	114.7 AV			1.49 V	8	109.9	4.8
4	#5929.60	60.3 PK	68.2	-7.9	1.49 V	8	55.2	5.1
5	11570.00	47.6 PK	74.0	-26.4	1.71 V	229	32.9	14.7
6	11570.00	36.2 AV	54.0	-17.8	1.71 V	229	21.5	14.7
7	#17355.00	59.8 PK	68.2	-8.4	1.61 V	196	41.0	18.8

Remarks:

1. Emission Level(dBuV/m) = Raw Value(dBuV) + Correction Factor(dB/m)
2. Correction Factor(dB/m) = Antenna Factor(dB/m) + Cable Factor(dB) – Pre-Amplifier Factor(dB)
3. Margin value = Emission Level – Limit value
4. The other emission levels were very low against the limit.
5. " * " : Fundamental frequency, the limit was restricted at the RF Output Power.
6. " # " : The radiated frequency is out of the restricted band.

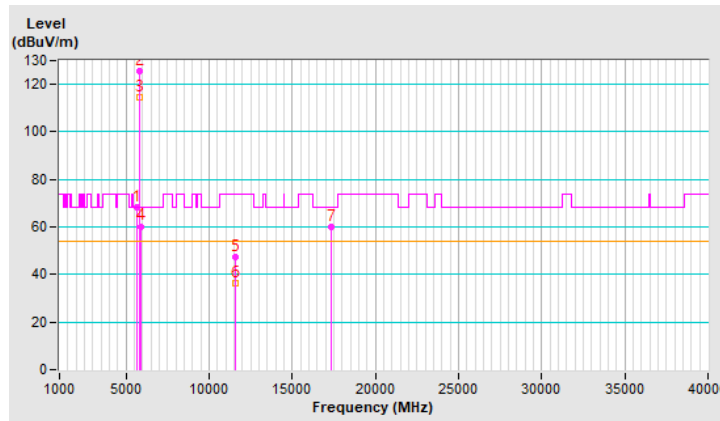

RF Mode	802.11ax (HE20)	Channel	CH 165 : 5825 MHz
Frequency Range	1 GHz ~ 40 GHz	Detector Function & Bandwidth	(PK) RB = 1 MHz, VB = 3 MHz (AV) RB = 1 MHz, VB = 10 Hz
Input Power	120 Vac, 60 Hz	Environmental Conditions	20°C, 70% RH
Tested By	Ryan Du		

Antenna Polarity & Test Distance : Horizontal at 3 m

No	Frequency (MHz)	Emission Level (dBuV/m)	Limit (dBuV/m)	Margin (dB)	Antenna Height (m)	Table Angle (Degree)	Raw Value (dBuV)	Correction Factor (dB/m)
1	#5635.43	55.0 PK	68.2	-13.2	1.48 H	133	50.4	4.6
2	*5825.00	120.1 PK			1.48 H	133	115.1	5.0
3	*5825.00	108.4 AV			1.48 H	133	103.4	5.0
4	#5925.82	54.7 PK	68.2	-13.5	1.48 H	133	49.6	5.1
5	11650.00	47.3 PK	74.0	-26.7	1.67 H	233	32.7	14.6
6	11650.00	36.7 AV	54.0	-17.3	1.67 H	233	22.1	14.6
7	#17475.00	58.6 PK	68.2	-9.6	1.60 H	43	39.1	19.5

Remarks:

1. Emission Level(dBuV/m) = Raw Value(dBuV) + Correction Factor(dB/m)
2. Correction Factor(dB/m) = Antenna Factor(dB/m) + Cable Factor(dB) – Pre-Amplifier Factor(dB)
3. Margin value = Emission Level – Limit value
4. The other emission levels were very low against the limit.
5. " * " : Fundamental frequency, the limit was restricted at the RF Output Power.
6. " # " : The radiated frequency is out of the restricted band.

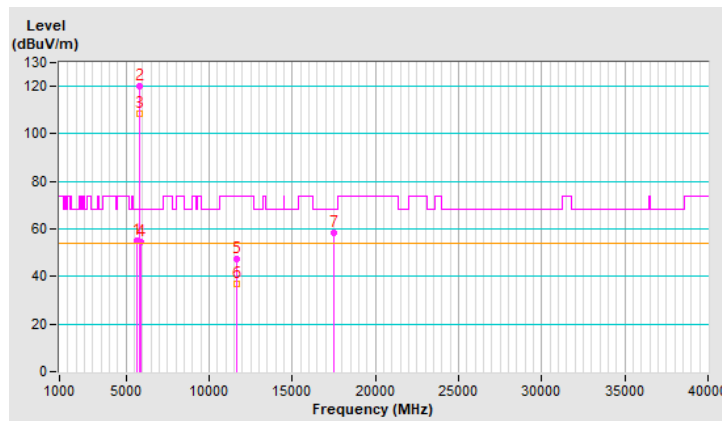

RF Mode	802.11ax (HE20)	Channel	CH 165 : 5825 MHz
Frequency Range	1 GHz ~ 40 GHz	Detector Function & Bandwidth	(PK) RB = 1 MHz, VB = 3 MHz (AV) RB = 1 MHz, VB = 10 Hz
Input Power	120 Vac, 60 Hz	Environmental Conditions	20°C, 70% RH
Tested By	Ryan Du		

Antenna Polarity & Test Distance : Vertical at 3 m								
No	Frequency (MHz)	Emission Level (dBuV/m)	Limit (dBuV/m)	Margin (dB)	Antenna Height (m)	Table Angle (Degree)	Raw Value (dBuV)	Correction Factor (dB/m)
1	#5635.99	63.2 PK	68.2	-5.0	1.37 V	16	58.6	4.6
2	*5825.00	125.4 PK			1.37 V	16	120.4	5.0
3	*5825.00	114.3 AV			1.37 V	16	109.3	5.0
4	#5925.73	67.8 PK	68.2	-0.4	1.37 V	16	62.7	5.1
5	11650.00	47.5 PK	74.0	-26.5	1.73 V	224	32.9	14.6
6	11650.00	36.2 AV	54.0	-17.8	1.73 V	224	21.6	14.6
7	#17475.00	59.2 PK	68.2	-9.0	1.59 V	201	39.7	19.5

Remarks:

1. Emission Level(dBuV/m) = Raw Value(dBuV) + Correction Factor(dB/m)
2. Correction Factor(dB/m) = Antenna Factor(dB/m) + Cable Factor(dB) – Pre-Amplifier Factor(dB)
3. Margin value = Emission Level – Limit value
4. The other emission levels were very low against the limit.
5. " * " : Fundamental frequency, the limit was restricted at the RF Output Power.
6. " # " : The radiated frequency is out of the restricted band.

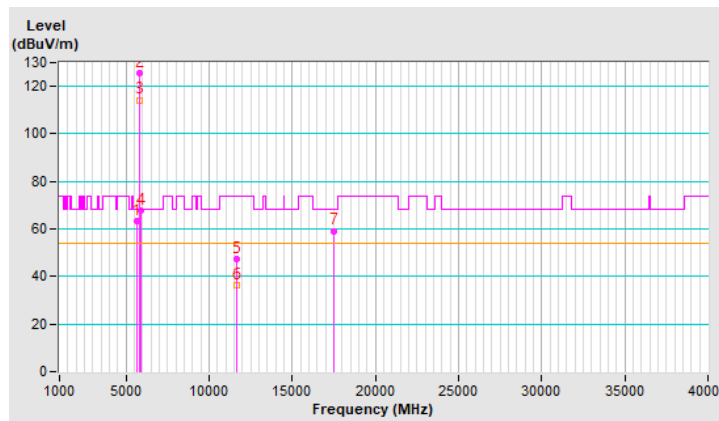

RF Mode	802.11ax (HE40)	Channel	CH 38 : 5190 MHz
Frequency Range	1 GHz ~ 40 GHz	Detector Function & Bandwidth	(PK) RB = 1 MHz, VB = 3 MHz (AV) RB = 1 MHz, VB = 10 Hz
Input Power	120 Vac, 60 Hz	Environmental Conditions	20°C, 70% RH
Tested By	Ryan Du		

Antenna Polarity & Test Distance : Horizontal at 3 m								
No	Frequency (MHz)	Emission Level (dBuV/m)	Limit (dBuV/m)	Margin (dB)	Antenna Height (m)	Table Angle (Degree)	Raw Value (dBuV)	Correction Factor (dB/m)
1	5150.00	59.2 PK	74.0	-14.8	1.49 H	150	54.7	4.5
2	5150.00	50.8 AV	54.0	-3.2	1.49 H	150	46.3	4.5
3	*5190.00	115.2 PK			1.49 H	150	110.8	4.4
4	*5190.00	103.4 AV			1.49 H	150	99.0	4.4
5	#10380.00	47.3 PK	68.2	-20.9	1.69 H	214	33.2	14.1
6	15570.00	58.7 PK	74.0	-15.3	1.64 H	43	44.6	14.1
7	15570.00	45.9 AV	54.0	-8.1	1.64 H	43	31.8	14.1

Remarks:

1. Emission Level(dBuV/m) = Raw Value(dBuV) + Correction Factor(dB/m)
2. Correction Factor(dB/m) = Antenna Factor(dB/m) + Cable Factor(dB) – Pre-Amplifier Factor(dB)
3. Margin value = Emission Level – Limit value
4. The other emission levels were very low against the limit.
5. " * " : Fundamental frequency, the limit was restricted at the RF Output Power.
6. " # " : The radiated frequency is out of the restricted band.

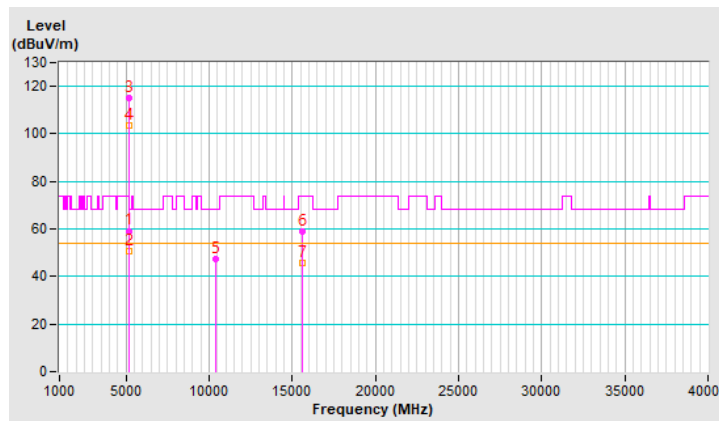

RF Mode	802.11ax (HE40)	Channel	CH 38 : 5190 MHz
Frequency Range	1 GHz ~ 40 GHz	Detector Function & Bandwidth	(PK) RB = 1 MHz, VB = 3 MHz (AV) RB = 1 MHz, VB = 10 Hz
Input Power	120 Vac, 60 Hz	Environmental Conditions	20°C, 70% RH
Tested By	Ryan Du		

Antenna Polarity & Test Distance : Vertical at 3 m								
No	Frequency (MHz)	Emission Level (dBuV/m)	Limit (dBuV/m)	Margin (dB)	Antenna Height (m)	Table Angle (Degree)	Raw Value (dBuV)	Correction Factor (dB/m)
1	5150.00	63.3 PK	74.0	-10.7	2.08 V	11	58.8	4.5
2	5150.00	53.9 AV	54.0	-0.1	2.08 V	11	49.4	4.5
3	*5190.00	117.1 PK			2.08 V	11	112.7	4.4
4	*5190.00	105.5 AV			2.08 V	11	101.1	4.4
5	#10380.00	48.0 PK	68.2	-20.2	1.73 V	214	33.9	14.1
6	15570.00	59.8 PK	74.0	-14.2	1.55 V	196	45.7	14.1
7	15570.00	47.3 AV	54.0	-6.7	1.55 V	196	33.2	14.1

Remarks:

1. Emission Level(dBuV/m) = Raw Value(dBuV) + Correction Factor(dB/m)
2. Correction Factor(dB/m) = Antenna Factor(dB/m) + Cable Factor(dB) – Pre-Amplifier Factor(dB)
3. Margin value = Emission Level – Limit value
4. The other emission levels were very low against the limit.
5. " * " : Fundamental frequency, the limit was restricted at the RF Output Power.
6. " # " : The radiated frequency is out of the restricted band.

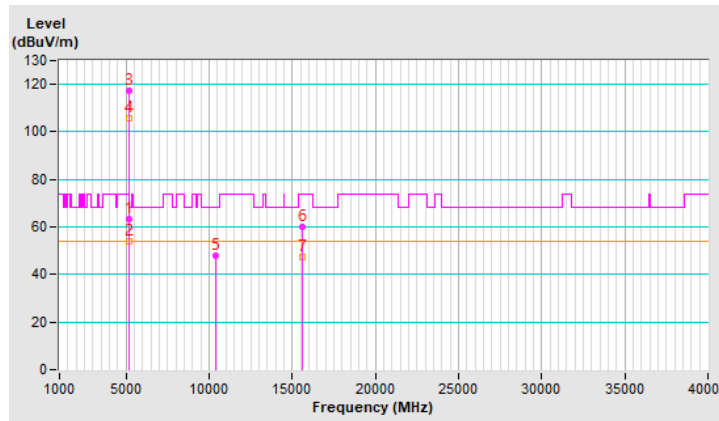

RF Mode	802.11ax (HE40)	Channel	CH 46 : 5230 MHz
Frequency Range	1 GHz ~ 40 GHz	Detector Function & Bandwidth	(PK) RB = 1 MHz, VB = 3 MHz (AV) RB = 1 MHz, VB = 10 Hz
Input Power	120 Vac, 60 Hz	Environmental Conditions	20°C, 70% RH
Tested By	Ryan Du		

Antenna Polarity & Test Distance : Horizontal at 3 m								
No	Frequency (MHz)	Emission Level (dBuV/m)	Limit (dBuV/m)	Margin (dB)	Antenna Height (m)	Table Angle (Degree)	Raw Value (dBuV)	Correction Factor (dB/m)
1	5150.00	61.9 PK	74.0	-12.1	1.57 H	155	57.4	4.5
2	5150.00	50.0 AV	54.0	-4.0	1.57 H	155	45.5	4.5
3	*5230.00	117.2 PK			1.57 H	155	113.0	4.2
4	*5230.00	106.7 AV			1.57 H	155	102.5	4.2
5	#10460.00	47.7 PK	68.2	-20.5	1.75 H	202	33.5	14.2
6	15690.00	58.2 PK	74.0	-15.8	1.66 H	44	43.7	14.5
7	15690.00	45.8 AV	54.0	-8.2	1.66 H	44	31.3	14.5

Remarks:

1. Emission Level(dBuV/m) = Raw Value(dBuV) + Correction Factor(dB/m)
2. Correction Factor(dB/m) = Antenna Factor(dB/m) + Cable Factor(dB) – Pre-Amplifier Factor(dB)
3. Margin value = Emission Level – Limit value
4. The other emission levels were very low against the limit.
5. " * " : Fundamental frequency, the limit was restricted at the RF Output Power.
6. " # " : The radiated frequency is out of the restricted band.

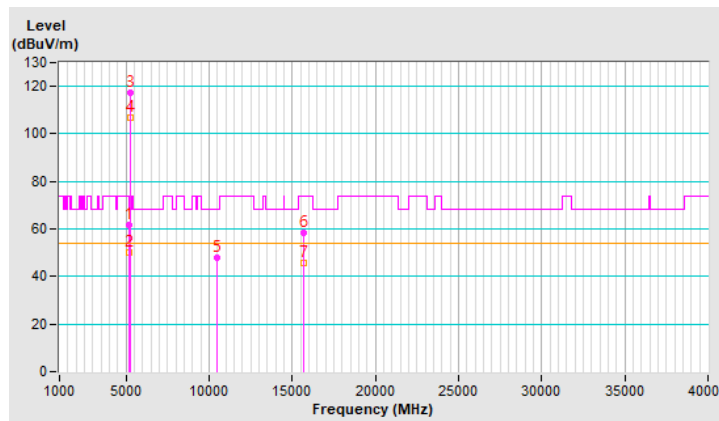

RF Mode	802.11ax (HE40)	Channel	CH 46 : 5230 MHz
Frequency Range	1 GHz ~ 40 GHz	Detector Function & Bandwidth	(PK) RB = 1 MHz, VB = 3 MHz (AV) RB = 1 MHz, VB = 10 Hz
Input Power	120 Vac, 60 Hz	Environmental Conditions	20°C, 70% RH
Tested By	Ryan Du		

Antenna Polarity & Test Distance : Vertical at 3 m								
No	Frequency (MHz)	Emission Level (dBuV/m)	Limit (dBuV/m)	Margin (dB)	Antenna Height (m)	Table Angle (Degree)	Raw Value (dBuV)	Correction Factor (dB/m)
1	5150.00	65.2 PK	74.0	-8.8	2.48 V	11	60.7	4.5
2	5150.00	53.7 AV	54.0	-0.3	2.48 V	11	49.2	4.5
3	*5230.00	120.1 PK			2.48 V	11	115.9	4.2
4	*5230.00	109.3 AV			2.48 V	11	105.1	4.2
5	#10460.00	48.0 PK	68.2	-20.2	1.73 V	220	33.8	14.2
6	15690.00	59.8 PK	74.0	-14.2	1.65 V	209	45.3	14.5
7	15690.00	47.4 AV	54.0	-6.6	1.65 V	209	32.9	14.5

Remarks:

1. Emission Level(dBuV/m) = Raw Value(dBuV) + Correction Factor(dB/m)
2. Correction Factor(dB/m) = Antenna Factor(dB/m) + Cable Factor(dB) – Pre-Amplifier Factor(dB)
3. Margin value = Emission Level – Limit value
4. The other emission levels were very low against the limit.
5. " * ": Fundamental frequency, the limit was restricted at the RF Output Power.
6. " # ": The radiated frequency is out of the restricted band.

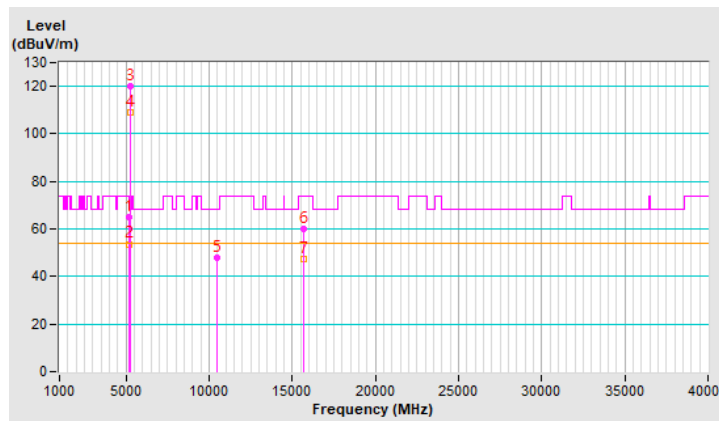

RF Mode	802.11ax (HE40)	Channel	CH 54 : 5270 MHz
Frequency Range	1 GHz ~ 40 GHz	Detector Function & Bandwidth	(PK) RB = 1 MHz, VB = 3 MHz (AV) RB = 1 MHz, VB = 10 Hz
Input Power	120 Vac, 60 Hz	Environmental Conditions	20°C, 70% RH
Tested By	Ryan Du		

Antenna Polarity & Test Distance : Horizontal at 3 m								
No	Frequency (MHz)	Emission Level (dBuV/m)	Limit (dBuV/m)	Margin (dB)	Antenna Height (m)	Table Angle (Degree)	Raw Value (dBuV)	Correction Factor (dB/m)
1	*5270.00	117.5 PK			1.52 H	149	113.5	4.0
2	*5270.00	106.7 AV			1.52 H	149	102.7	4.0
3	5350.00	60.2 PK	74.0	-13.8	1.52 H	149	56.0	4.2
4	5350.00	49.5 AV	54.0	-4.5	1.52 H	149	45.3	4.2
5	#10540.00	47.7 PK	68.2	-20.5	1.67 H	210	33.8	13.9
6	15810.00	58.3 PK	74.0	-15.7	1.61 H	32	43.9	14.4
7	15810.00	45.8 AV	54.0	-8.2	1.61 H	32	31.4	14.4

Remarks:

1. Emission Level(dBuV/m) = Raw Value(dBuV) + Correction Factor(dB/m)
2. Correction Factor(dB/m) = Antenna Factor(dB/m) + Cable Factor(dB) – Pre-Amplifier Factor(dB)
3. Margin value = Emission Level – Limit value
4. The other emission levels were very low against the limit.
5. " * " : Fundamental frequency, the limit was restricted at the RF Output Power.
6. " # " : The radiated frequency is out of the restricted band.

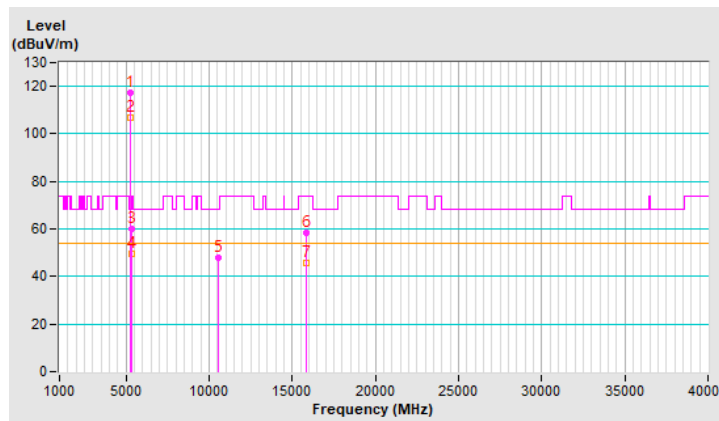

RF Mode	802.11ax (HE40)	Channel	CH 54 : 5270 MHz
Frequency Range	1 GHz ~ 40 GHz	Detector Function & Bandwidth	(PK) RB = 1 MHz, VB = 3 MHz (AV) RB = 1 MHz, VB = 10 Hz
Input Power	120 Vac, 60 Hz	Environmental Conditions	20°C, 70% RH
Tested By	Ryan Du		

Antenna Polarity & Test Distance : Vertical at 3 m								
No	Frequency (MHz)	Emission Level (dBuV/m)	Limit (dBuV/m)	Margin (dB)	Antenna Height (m)	Table Angle (Degree)	Raw Value (dBuV)	Correction Factor (dB/m)
1	*5270.00	120.2 PK			2.25 V	10	116.2	4.0
2	*5270.00	109.0 AV			2.25 V	10	105.0	4.0
3	5350.30	64.3 PK	74.0	-9.7	2.25 V	10	60.1	4.2
4	5350.30	53.7 AV	54.0	-0.3	2.25 V	10	49.5	4.2
5	#10540.00	47.5 PK	68.2	-20.7	1.76 V	211	33.6	13.9
6	15810.00	60.1 PK	74.0	-13.9	1.56 V	177	45.7	14.4
7	15810.00	47.5 AV	54.0	-6.5	1.56 V	177	33.1	14.4

Remarks:

1. Emission Level(dBuV/m) = Raw Value(dBuV) + Correction Factor(dB/m)
2. Correction Factor(dB/m) = Antenna Factor(dB/m) + Cable Factor(dB) – Pre-Amplifier Factor(dB)
3. Margin value = Emission Level – Limit value
4. The other emission levels were very low against the limit.
5. " * " : Fundamental frequency, the limit was restricted at the RF Output Power.
6. " # " : The radiated frequency is out of the restricted band.

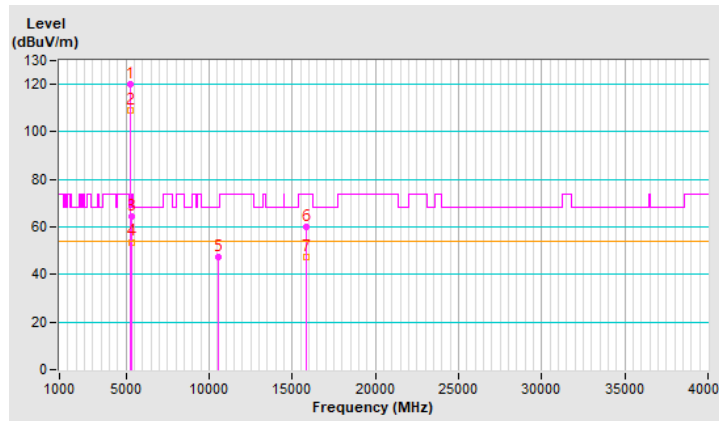

RF Mode	802.11ax (HE40)	Channel	CH 62 : 5310 MHz
Frequency Range	1 GHz ~ 40 GHz	Detector Function & Bandwidth	(PK) RB = 1 MHz, VB = 3 MHz (AV) RB = 1 MHz, VB = 10 Hz
Input Power	120 Vac, 60 Hz	Environmental Conditions	20°C, 70% RH
Tested By	Ryan Du		

Antenna Polarity & Test Distance : Horizontal at 3 m

No	Frequency (MHz)	Emission Level (dBuV/m)	Limit (dBuV/m)	Margin (dB)	Antenna Height (m)	Table Angle (Degree)	Raw Value (dBuV)	Correction Factor (dB/m)
1	*5310.00	113.1 PK			1.47 H	148	109.1	4.0
2	*5310.00	101.2 AV			1.47 H	148	97.2	4.0
3	5350.00	58.0 PK	74.0	-16.0	1.47 H	148	53.8	4.2
4	5350.00	48.3 AV	54.0	-5.7	1.47 H	148	44.1	4.2
5	10620.00	47.1 PK	74.0	-26.9	1.72 H	215	33.4	13.7
6	10620.00	36.5 AV	54.0	-17.5	1.72 H	215	22.8	13.7
7	15930.00	58.9 PK	74.0	-15.1	1.63 H	35	44.3	14.6
8	15930.00	46.2 AV	54.0	-7.8	1.63 H	35	31.6	14.6

Remarks:

1. Emission Level(dBuV/m) = Raw Value(dBuV) + Correction Factor(dB/m)
2. Correction Factor(dB/m) = Antenna Factor(dB/m) + Cable Factor(dB) – Pre-Amplifier Factor(dB)
3. Margin value = Emission Level – Limit value
4. The other emission levels were very low against the limit.
5. " * " : Fundamental frequency, the limit was restricted at the RF Output Power.

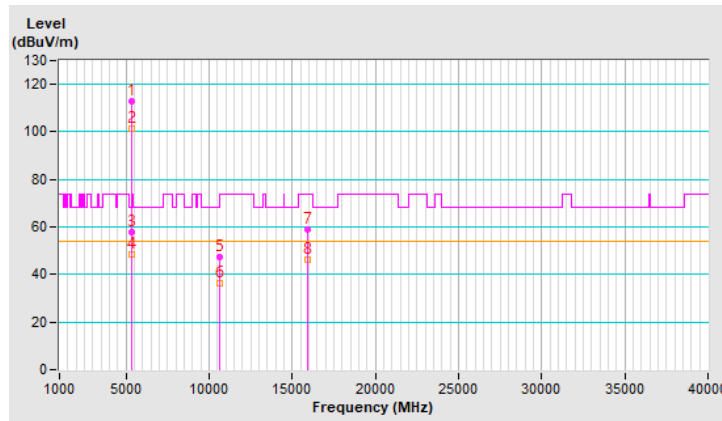

RF Mode	802.11ax (HE40)	Channel	CH 62 : 5310 MHz
Frequency Range	1 GHz ~ 40 GHz	Detector Function & Bandwidth	(PK) RB = 1 MHz, VB = 3 MHz (AV) RB = 1 MHz, VB = 10 Hz
Input Power	120 Vac, 60 Hz	Environmental Conditions	20°C, 70% RH
Tested By	Ryan Du		

Antenna Polarity & Test Distance : Vertical at 3 m								
No	Frequency (MHz)	Emission Level (dBuV/m)	Limit (dBuV/m)	Margin (dB)	Antenna Height (m)	Table Angle (Degree)	Raw Value (dBuV)	Correction Factor (dB/m)
1	*5310.00	116.3 PK			2.09 V	11	112.3	4.0
2	*5310.00	104.4 AV			2.09 V	11	100.4	4.0
3	5350.00	63.0 PK	74.0	-11.0	2.09 V	11	58.8	4.2
4	5350.00	53.8 AV	54.0	-0.2	2.09 V	11	49.6	4.2
5	10620.00	47.9 PK	74.0	-26.1	1.79 V	206	34.2	13.7
6	10620.00	36.5 AV	54.0	-17.5	1.79 V	206	22.8	13.7
7	15930.00	59.3 PK	74.0	-14.7	1.60 V	182	44.7	14.6
8	15930.00	46.8 AV	54.0	-7.2	1.60 V	182	32.2	14.6

Remarks:

1. Emission Level(dBuV/m) = Raw Value(dBuV) + Correction Factor(dB/m)
2. Correction Factor(dB/m) = Antenna Factor(dB/m) + Cable Factor(dB) – Pre-Amplifier Factor(dB)
3. Margin value = Emission Level – Limit value
4. The other emission levels were very low against the limit.
5. " * " : Fundamental frequency, the limit was restricted at the RF Output Power.

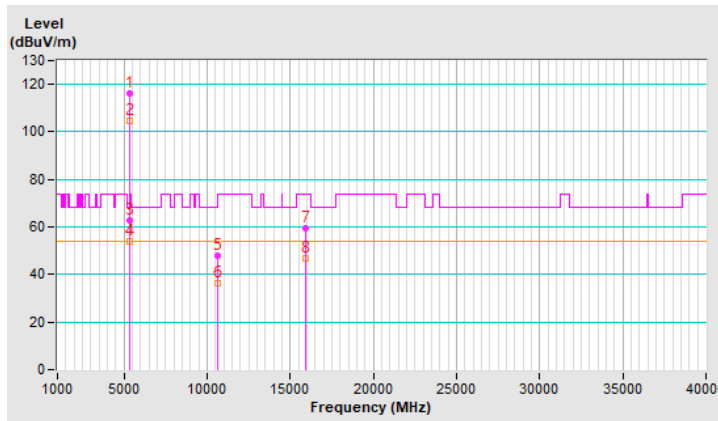

RF Mode	802.11ax (HE40)	Channel	CH 102 : 5510 MHz
Frequency Range	1 GHz ~ 40 GHz	Detector Function & Bandwidth	(PK) RB = 1 MHz, VB = 3 MHz (AV) RB = 1 MHz, VB = 10 Hz
Input Power	120 Vac, 60 Hz	Environmental Conditions	20°C, 70% RH
Tested By	Ryan Du		

Antenna Polarity & Test Distance : Horizontal at 3 m								
No	Frequency (MHz)	Emission Level (dBuV/m)	Limit (dBuV/m)	Margin (dB)	Antenna Height (m)	Table Angle (Degree)	Raw Value (dBuV)	Correction Factor (dB/m)
1	5455.14	59.8 PK	74.0	-14.2	1.54 H	151	55.4	4.4
2	5455.14	49.1 AV	54.0	-4.9	1.54 H	151	44.7	4.4
3	#5470.00	62.5 PK	68.2	-5.7	1.54 H	151	58.1	4.4
4	*5510.00	114.6 PK			1.54 H	151	110.1	4.5
5	*5510.00	103.5 AV			1.54 H	151	99.0	4.5
6	11020.00	47.6 PK	74.0	-26.4	1.71 H	221	33.2	14.4
7	11020.00	36.9 AV	54.0	-17.1	1.71 H	221	22.5	14.4
8	#16530.00	57.9 PK	68.2	-10.3	1.57 H	26	41.0	16.9

Remarks:

1. Emission Level(dBuV/m) = Raw Value(dBuV) + Correction Factor(dB/m)
2. Correction Factor(dB/m) = Antenna Factor(dB/m) + Cable Factor(dB) – Pre-Amplifier Factor(dB)
3. Margin value = Emission Level – Limit value
4. The other emission levels were very low against the limit.
5. " * " : Fundamental frequency, the limit was restricted at the RF Output Power.
6. " # " : The radiated frequency is out of the restricted band.

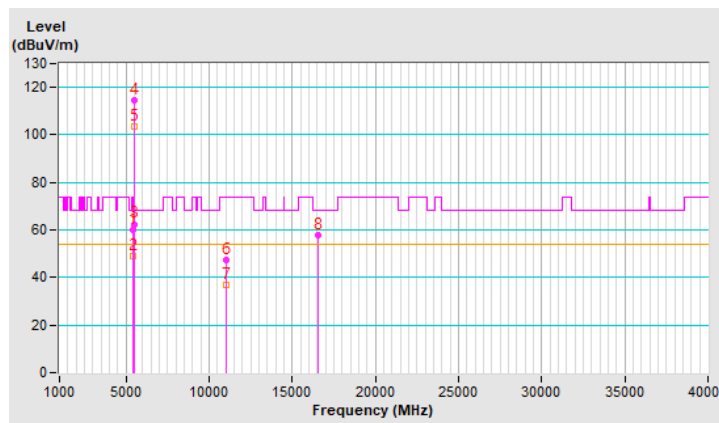

RF Mode	802.11ax (HE40)	Channel	CH 102 : 5510 MHz
Frequency Range	1 GHz ~ 40 GHz	Detector Function & Bandwidth	(PK) RB = 1 MHz, VB = 3 MHz (AV) RB = 1 MHz, VB = 10 Hz
Input Power	120 Vac, 60 Hz	Environmental Conditions	20°C, 70% RH
Tested By	Ryan Du		

Antenna Polarity & Test Distance : Vertical at 3 m

No	Frequency (MHz)	Emission Level (dBuV/m)	Limit (dBuV/m)	Margin (dB)	Antenna Height (m)	Table Angle (Degree)	Raw Value (dBuV)	Correction Factor (dB/m)
1	5458.84	63.5 PK	74.0	-10.5	1.88 V	12	59.1	4.4
2	5458.84	52.2 AV	54.0	-1.8	1.88 V	12	47.8	4.4
3	#5470.00	67.8 PK	68.2	-0.4	1.88 V	12	63.4	4.4
4	*5510.00	117.8 PK			1.88 V	12	113.3	4.5
5	*5510.00	107.4 AV			1.88 V	12	102.9	4.5
6	11020.00	48.1 PK	74.0	-25.9	1.74 V	218	33.7	14.4
7	11020.00	36.9 AV	54.0	-17.1	1.74 V	218	22.5	14.4
8	#16530.00	59.0 PK	68.2	-9.2	1.58 V	181	42.1	16.9

Remarks:

1. Emission Level(dBuV/m) = Raw Value(dBuV) + Correction Factor(dB/m)
2. Correction Factor(dB/m) = Antenna Factor(dB/m) + Cable Factor(dB) – Pre-Amplifier Factor(dB)
3. Margin value = Emission Level – Limit value
4. The other emission levels were very low against the limit.
5. " * " : Fundamental frequency, the limit was restricted at the RF Output Power.
6. " # " : The radiated frequency is out of the restricted band.

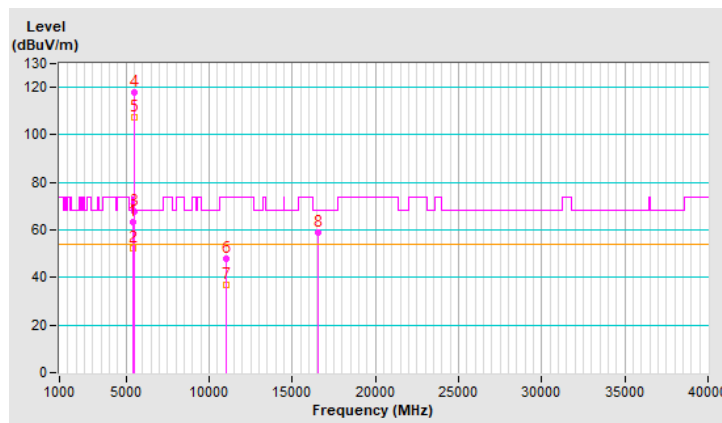

RF Mode	802.11ax (HE40)	Channel	CH 110 : 5550 MHz
Frequency Range	1 GHz ~ 40 GHz	Detector Function & Bandwidth	(PK) RB = 1 MHz, VB = 3 MHz (AV) RB = 1 MHz, VB = 10 Hz
Input Power	120 Vac, 60 Hz	Environmental Conditions	20°C, 70% RH
Tested By	Ryan Du		

Antenna Polarity & Test Distance : Horizontal at 3 m

No	Frequency (MHz)	Emission Level (dBuV/m)	Limit (dBuV/m)	Margin (dB)	Antenna Height (m)	Table Angle (Degree)	Raw Value (dBuV)	Correction Factor (dB/m)
1	5460.00	62.0 PK	74.0	-12.0	1.50 H	159	57.6	4.4
2	5460.00	50.8 AV	54.0	-3.2	1.50 H	159	46.4	4.4
3	#5470.00	66.1 PK	68.2	-2.1	1.50 H	159	61.7	4.4
4	*5550.00	118.0 PK			1.50 H	159	113.6	4.4
5	*5550.00	107.2 AV			1.50 H	159	102.8	4.4
6	11100.00	46.8 PK	74.0	-27.2	1.75 H	206	32.9	13.9
7	11100.00	36.1 AV	54.0	-17.9	1.75 H	206	22.2	13.9
8	#16650.00	58.7 PK	68.2	-9.5	1.57 H	34	41.1	17.6

Remarks:

1. Emission Level(dBuV/m) = Raw Value(dBuV) + Correction Factor(dB/m)
2. Correction Factor(dB/m) = Antenna Factor(dB/m) + Cable Factor(dB) – Pre-Amplifier Factor(dB)
3. Margin value = Emission Level – Limit value
4. The other emission levels were very low against the limit.
5. " * " : Fundamental frequency, the limit was restricted at the RF Output Power.
6. " # " : The radiated frequency is out of the restricted band.

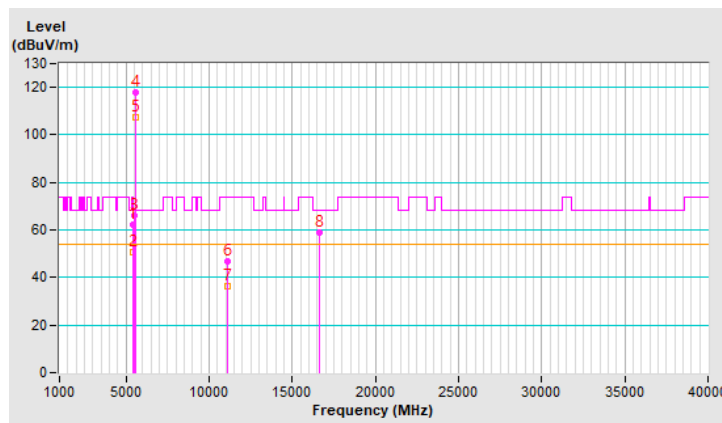

RF Mode	802.11ax (HE40)	Channel	CH 110 : 5550 MHz
Frequency Range	1 GHz ~ 40 GHz	Detector Function & Bandwidth	(PK) RB = 1 MHz, VB = 3 MHz (AV) RB = 1 MHz, VB = 10 Hz
Input Power	120 Vac, 60 Hz	Environmental Conditions	20°C, 70% RH
Tested By	Ryan Du		

Antenna Polarity & Test Distance : Vertical at 3 m								
No	Frequency (MHz)	Emission Level (dBuV/m)	Limit (dBuV/m)	Margin (dB)	Antenna Height (m)	Table Angle (Degree)	Raw Value (dBuV)	Correction Factor (dB/m)
1	5460.00	64.7 PK	74.0	-9.3	1.84 V	14	60.3	4.4
2	5460.00	53.8 AV	54.0	-0.2	1.84 V	14	49.4	4.4
3	#5470.00	67.8 PK	68.2	-0.4	1.84 V	14	63.4	4.4
4	*5550.00	120.7 PK			1.84 V	14	116.3	4.4
5	*5550.00	110.3 AV			1.84 V	14	105.9	4.4
6	11100.00	48.5 PK	74.0	-25.5	1.81 V	209	34.6	13.9
7	11100.00	37.0 AV	54.0	-17.0	1.81 V	209	23.1	13.9
8	#16650.00	60.1 PK	68.2	-8.1	1.58 V	187	42.5	17.6

Remarks:

1. Emission Level(dBuV/m) = Raw Value(dBuV) + Correction Factor(dB/m)
2. Correction Factor(dB/m) = Antenna Factor(dB/m) + Cable Factor(dB) – Pre-Amplifier Factor(dB)
3. Margin value = Emission Level – Limit value
4. The other emission levels were very low against the limit.
5. " * " : Fundamental frequency, the limit was restricted at the RF Output Power.
6. " # " : The radiated frequency is out of the restricted band.

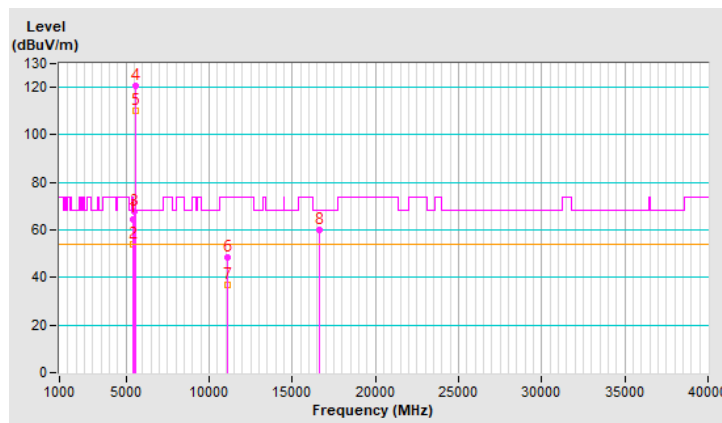

RF Mode	802.11ax (HE40)	Channel	CH 134 : 5670 MHz
Frequency Range	1 GHz ~ 40 GHz	Detector Function & Bandwidth	(PK) RB = 1 MHz, VB = 3 MHz (AV) RB = 1 MHz, VB = 10 Hz
Input Power	120 Vac, 60 Hz	Environmental Conditions	20°C, 70% RH
Tested By	Ryan Du		

Antenna Polarity & Test Distance : Horizontal at 3 m

No	Frequency (MHz)	Emission Level (dBuV/m)	Limit (dBuV/m)	Margin (dB)	Antenna Height (m)	Table Angle (Degree)	Raw Value (dBuV)	Correction Factor (dB/m)
1	*5670.00	115.7 PK			1.52 H	134	111.2	4.5
2	*5670.00	103.3 AV			1.52 H	134	98.8	4.5
3	#5725.00	64.2 PK	68.2	-4.0	1.52 H	134	59.6	4.6
4	11340.00	47.0 PK	74.0	-27.0	1.72 H	201	32.2	14.8
5	11340.00	36.0 AV	54.0	-18.0	1.72 H	201	21.2	14.8
6	#17010.00	58.7 PK	68.2	-9.5	1.62 H	41	39.6	19.1

Remarks:

1. Emission Level(dBuV/m) = Raw Value(dBuV) + Correction Factor(dB/m)
2. Correction Factor(dB/m) = Antenna Factor(dB/m) + Cable Factor(dB) – Pre-Amplifier Factor(dB)
3. Margin value = Emission Level – Limit value
4. The other emission levels were very low against the limit.
5. " * " : Fundamental frequency, the limit was restricted at the RF Output Power.
6. " # " : The radiated frequency is out of the restricted band.

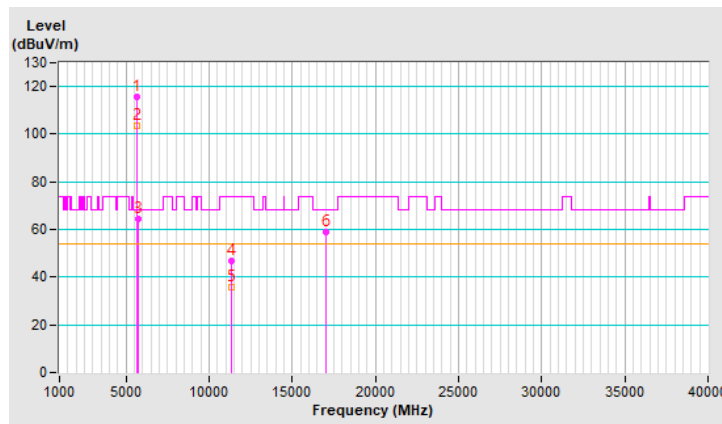

RF Mode	802.11ax (HE40)	Channel	CH 134 : 5670 MHz
Frequency Range	1 GHz ~ 40 GHz	Detector Function & Bandwidth	(PK) RB = 1 MHz, VB = 3 MHz (AV) RB = 1 MHz, VB = 10 Hz
Input Power	120 Vac, 60 Hz	Environmental Conditions	20°C, 70% RH
Tested By	Ryan Du		

Antenna Polarity & Test Distance : Vertical at 3 m								
No	Frequency (MHz)	Emission Level (dBuV/m)	Limit (dBuV/m)	Margin (dB)	Antenna Height (m)	Table Angle (Degree)	Raw Value (dBuV)	Correction Factor (dB/m)
1	*5670.00	119.3 PK			1.95 V	12	114.8	4.5
2	*5670.00	107.9 AV			1.95 V	12	103.4	4.5
3	#5730.34	67.8 PK	68.2	-0.4	1.95 V	12	63.2	4.6
4	11340.00	47.9 PK	74.0	-26.1	1.81 V	213	33.1	14.8
5	11340.00	36.7 AV	54.0	-17.3	1.81 V	213	21.9	14.8
6	#17010.00	58.9 PK	68.2	-9.3	1.60 V	201	39.8	19.1

Remarks:

1. Emission Level(dBuV/m) = Raw Value(dBuV) + Correction Factor(dB/m)
2. Correction Factor(dB/m) = Antenna Factor(dB/m) + Cable Factor(dB) – Pre-Amplifier Factor(dB)
3. Margin value = Emission Level – Limit value
4. The other emission levels were very low against the limit.
5. " * " : Fundamental frequency, the limit was restricted at the RF Output Power.
6. " # " : The radiated frequency is out of the restricted band.

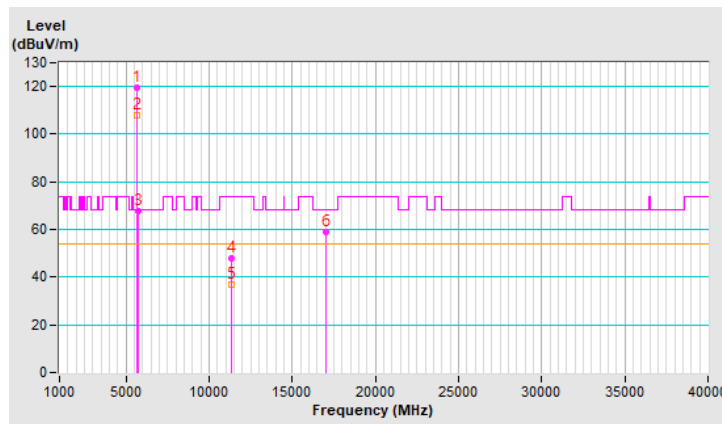

RF Mode	802.11ax (HE40)	Channel	CH 142 : 5710 MHz
Frequency Range	1 GHz ~ 40 GHz	Detector Function & Bandwidth	(PK) RB = 1 MHz, VB = 3 MHz (AV) RB = 1 MHz, VB = 10 Hz
Input Power	120 Vac, 60 Hz	Environmental Conditions	20°C, 70% RH
Tested By	Ryan Du		

Antenna Polarity & Test Distance : Horizontal at 3 m

No	Frequency (MHz)	Emission Level (dBuV/m)	Limit (dBuV/m)	Margin (dB)	Antenna Height (m)	Table Angle (Degree)	Raw Value (dBuV)	Correction Factor (dB/m)
1	*5710.00	117.5 PK			1.50 H	161	113.0	4.5
2	*5710.00	106.5 AV			1.50 H	161	102.0	4.5
3	11420.00	47.3 PK	74.0	-26.7	1.67 H	208	32.4	14.9
4	11420.00	36.4 AV	54.0	-17.6	1.67 H	208	21.5	14.9
5	#17130.00	58.5 PK	68.2	-9.7	1.67 H	38	39.3	19.2

Remarks:

1. Emission Level(dBuV/m) = Raw Value(dBuV) + Correction Factor(dB/m)
2. Correction Factor(dB/m) = Antenna Factor(dB/m) + Cable Factor(dB) – Pre-Amplifier Factor(dB)
3. Margin value = Emission Level – Limit value
4. The other emission levels were very low against the limit.
5. " * " : Fundamental frequency, the limit was restricted at the RF Output Power.
6. " # " : The radiated frequency is out of the restricted band.

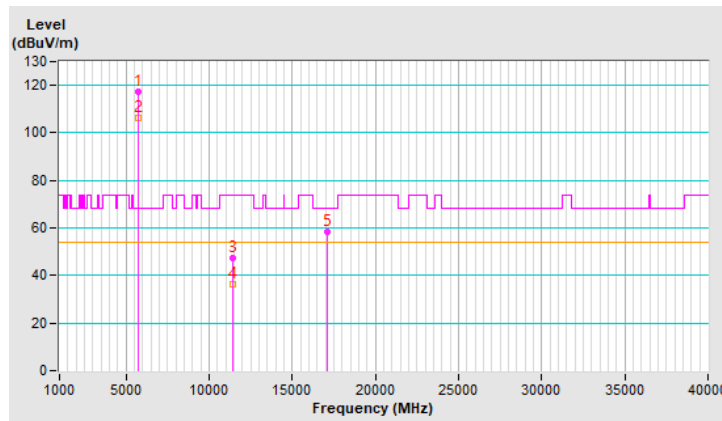

RF Mode	802.11ax (HE40)	Channel	CH 142 : 5710 MHz
Frequency Range	1 GHz ~ 40 GHz	Detector Function & Bandwidth	(PK) RB = 1 MHz, VB = 3 MHz (AV) RB = 1 MHz, VB = 10 Hz
Input Power	120 Vac, 60 Hz	Environmental Conditions	20°C, 70% RH
Tested By	Ryan Du		

Antenna Polarity & Test Distance : Vertical at 3 m								
No	Frequency (MHz)	Emission Level (dBuV/m)	Limit (dBuV/m)	Margin (dB)	Antenna Height (m)	Table Angle (Degree)	Raw Value (dBuV)	Correction Factor (dB/m)
1	*5710.00	120.8 PK			1.57 V	51	116.3	4.5
2	*5710.00	110.5 AV			1.57 V	51	106.0	4.5
3	11420.00	48.1 PK	74.0	-25.9	1.82 V	211	33.2	14.9
4	11420.00	37.0 AV	54.0	-17.0	1.82 V	211	22.1	14.9
5	#17130.00	59.7 PK	68.2	-8.5	1.57 V	205	40.5	19.2

Remarks:

1. Emission Level(dBuV/m) = Raw Value(dBuV) + Correction Factor(dB/m)
2. Correction Factor(dB/m) = Antenna Factor(dB/m) + Cable Factor(dB) – Pre-Amplifier Factor(dB)
3. Margin value = Emission Level – Limit value
4. The other emission levels were very low against the limit.
5. " * " : Fundamental frequency, the limit was restricted at the RF Output Power.
6. " # " : The radiated frequency is out of the restricted band.

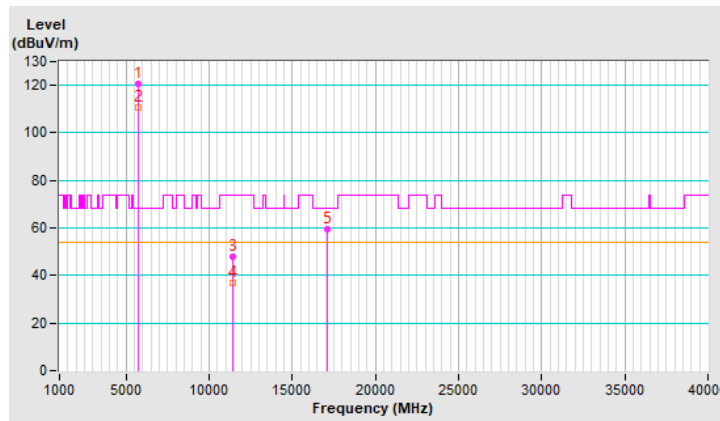

RF Mode	802.11ax (HE40)	Channel	CH 151 : 5755 MHz
Frequency Range	1 GHz ~ 40 GHz	Detector Function & Bandwidth	(PK) RB = 1 MHz, VB = 3 MHz (AV) RB = 1 MHz, VB = 10 Hz
Input Power	120 Vac, 60 Hz	Environmental Conditions	20°C, 70% RH
Tested By	Ryan Du		

Antenna Polarity & Test Distance : Horizontal at 3 m

No	Frequency (MHz)	Emission Level (dBUV/m)	Limit (dBUV/m)	Margin (dB)	Antenna Height (m)	Table Angle (Degree)	Raw Value (dBUV)	Correction Factor (dB/m)
1	#5646.42	63.1 PK	68.2	-5.1	1.54 H	156	58.4	4.7
2	*5755.00	117.2 PK			1.54 H	156	112.7	4.5
3	*5755.00	106.5 AV			1.54 H	156	102.0	4.5
4	#5926.72	54.4 PK	68.2	-13.8	1.54 H	156	49.3	5.1
5	11510.00	46.8 PK	74.0	-27.2	1.68 H	225	31.9	14.9
6	11510.00	36.0 AV	54.0	-18.0	1.68 H	225	21.1	14.9
7	#17265.00	58.7 PK	68.2	-9.5	1.65 H	23	40.1	18.6

Remarks:

1. Emission Level(dBUV/m) = Raw Value(dBUV) + Correction Factor(dB/m)
2. Correction Factor(dB/m) = Antenna Factor(dB/m) + Cable Factor(dB) – Pre-Amplifier Factor(dB)
3. Margin value = Emission Level – Limit value
4. The other emission levels were very low against the limit.
5. " * " : Fundamental frequency, the limit was restricted at the RF Output Power.
6. " # " : The radiated frequency is out of the restricted band.

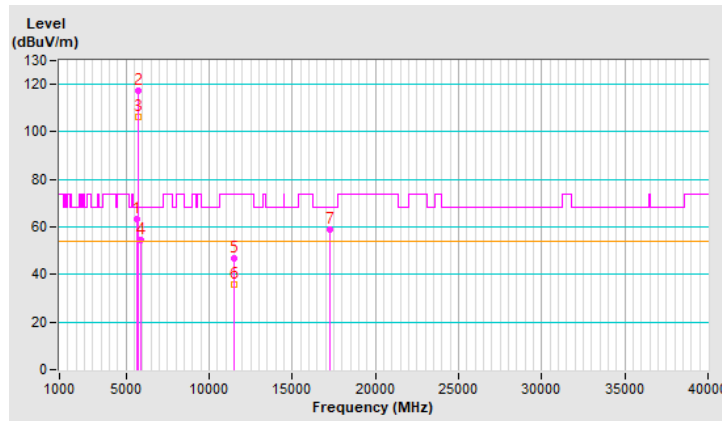

RF Mode	802.11ax (HE40)	Channel	CH 151 : 5755 MHz
Frequency Range	1 GHz ~ 40 GHz	Detector Function & Bandwidth	(PK) RB = 1 MHz, VB = 3 MHz (AV) RB = 1 MHz, VB = 10 Hz
Input Power	120 Vac, 60 Hz	Environmental Conditions	20°C, 70% RH
Tested By	Ryan Du		

Antenna Polarity & Test Distance : Vertical at 3 m

No	Frequency (MHz)	Emission Level (dBuV/m)	Limit (dBuV/m)	Margin (dB)	Antenna Height (m)	Table Angle (Degree)	Raw Value (dBuV)	Correction Factor (dB/m)
1	#5645.05	67.8 PK	68.2	-0.4	1.90 V	12	63.1	4.7
2	*5755.00	120.9 PK			1.90 V	12	116.4	4.5
3	*5755.00	110.5 AV			1.90 V	12	106.0	4.5
4	#5927.44	55.1 PK	68.2	-13.1	1.90 V	12	50.0	5.1
5	11510.00	47.6 PK	74.0	-26.4	1.80 V	204	32.7	14.9
6	11510.00	36.3 AV	54.0	-17.7	1.80 V	204	21.4	14.9
7	#17265.00	59.7 PK	68.2	-8.5	1.59 V	184	41.1	18.6

Remarks:

1. Emission Level(dBuV/m) = Raw Value(dBuV) + Correction Factor(dB/m)
2. Correction Factor(dB/m) = Antenna Factor(dB/m) + Cable Factor(dB) – Pre-Amplifier Factor(dB)
3. Margin value = Emission Level – Limit value
4. The other emission levels were very low against the limit.
5. " * " : Fundamental frequency, the limit was restricted at the RF Output Power.
6. " # " : The radiated frequency is out of the restricted band.

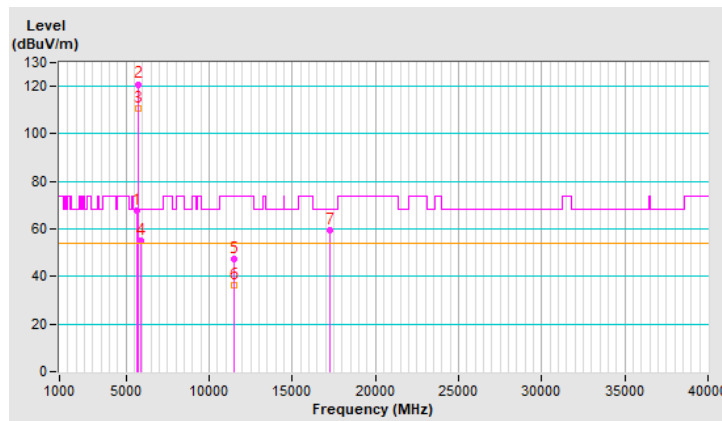

RF Mode	802.11ax (HE40)	Channel	CH 159 : 5795 MHz
Frequency Range	1 GHz ~ 40 GHz	Detector Function & Bandwidth	(PK) RB = 1 MHz, VB = 3 MHz (AV) RB = 1 MHz, VB = 10 Hz
Input Power	120 Vac, 60 Hz	Environmental Conditions	20°C, 70% RH
Tested By	Ryan Du		

Antenna Polarity & Test Distance : Horizontal at 3 m

No	Frequency (MHz)	Emission Level (dBuV/m)	Limit (dBuV/m)	Margin (dB)	Antenna Height (m)	Table Angle (Degree)	Raw Value (dBuV)	Correction Factor (dB/m)
1	#5643.12	62.8 PK	68.2	-5.4	1.51 H	127	58.1	4.7
2	*5795.00	118.5 PK			1.51 H	127	113.6	4.9
3	*5795.00	107.5 AV			1.51 H	127	102.6	4.9
4	#5932.75	61.7 PK	68.2	-6.5	1.51 H	127	56.6	5.1
5	11590.00	47.0 PK	74.0	-27.0	1.66 H	204	32.4	14.6
6	11590.00	36.1 AV	54.0	-17.9	1.66 H	204	21.5	14.6
7	#17385.00	58.2 PK	68.2	-10.0	1.59 H	36	39.3	18.9

Remarks:

1. Emission Level(dBuV/m) = Raw Value(dBuV) + Correction Factor(dB/m)
2. Correction Factor(dB/m) = Antenna Factor(dB/m) + Cable Factor(dB) – Pre-Amplifier Factor(dB)
3. Margin value = Emission Level – Limit value
4. The other emission levels were very low against the limit.
5. " * " : Fundamental frequency, the limit was restricted at the RF Output Power.
6. " # " : The radiated frequency is out of the restricted band.

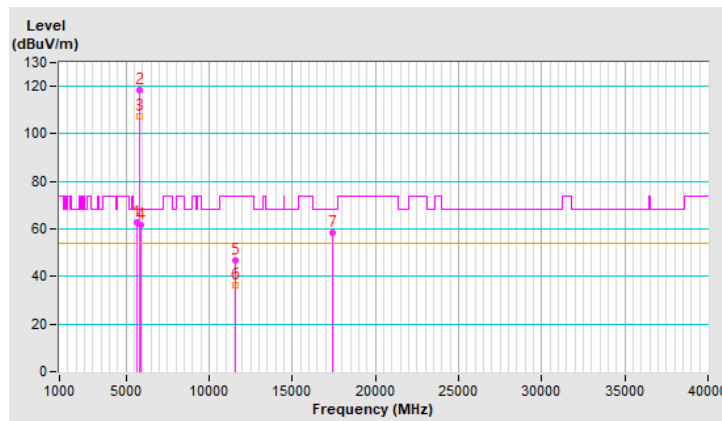

RF Mode	802.11ax (HE40)	Channel	CH 159 : 5795 MHz
Frequency Range	1 GHz ~ 40 GHz	Detector Function & Bandwidth	(PK) RB = 1 MHz, VB = 3 MHz (AV) RB = 1 MHz, VB = 10 Hz
Input Power	120 Vac, 60 Hz	Environmental Conditions	20°C, 70% RH
Tested By	Ryan Du		

Antenna Polarity & Test Distance : Vertical at 3 m								
No	Frequency (MHz)	Emission Level (dBuV/m)	Limit (dBuV/m)	Margin (dB)	Antenna Height (m)	Table Angle (Degree)	Raw Value (dBuV)	Correction Factor (dB/m)
1	#5647.83	67.8 PK	68.2	-0.4	1.71 V	11	63.1	4.7
2	*5795.00	122.9 PK			1.71 V	11	118.0	4.9
3	*5795.00	111.2 AV			1.71 V	11	106.3	4.9
4	#5925.00	68.0 PK	68.2	-0.2	1.71 V	11	62.9	5.1
5	11590.00	47.9 PK	74.0	-26.1	1.81 V	212	33.3	14.6
6	11590.00	36.7 AV	54.0	-17.3	1.81 V	212	22.1	14.6
7	#17385.00	59.2 PK	68.2	-9.0	1.62 V	182	40.3	18.9

Remarks:

1. Emission Level(dBuV/m) = Raw Value(dBuV) + Correction Factor(dB/m)
2. Correction Factor(dB/m) = Antenna Factor(dB/m) + Cable Factor(dB) – Pre-Amplifier Factor(dB)
3. Margin value = Emission Level – Limit value
4. The other emission levels were very low against the limit.
5. " * " : Fundamental frequency, the limit was restricted at the RF Output Power.
6. " # " : The radiated frequency is out of the restricted band.

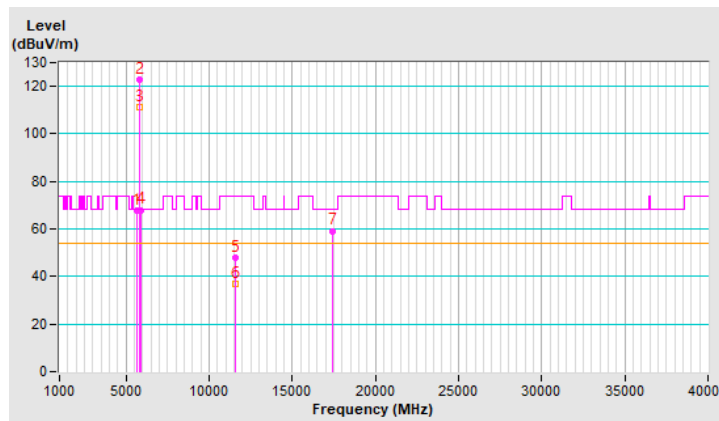

RF Mode	802.11ax (HE80)	Channel	CH 42 : 5210 MHz
Frequency Range	1 GHz ~ 40 GHz	Detector Function & Bandwidth	(PK) RB = 1 MHz, VB = 3 MHz (AV) RB = 1 MHz, VB = 10 Hz
Input Power	120 Vac, 60 Hz	Environmental Conditions	20°C, 70% RH
Tested By	Ryan Du		

Antenna Polarity & Test Distance : Horizontal at 3 m								
No	Frequency (MHz)	Emission Level (dBuV/m)	Limit (dBuV/m)	Margin (dB)	Antenna Height (m)	Table Angle (Degree)	Raw Value (dBuV)	Correction Factor (dB/m)
1	5150.00	60.3 PK	74.0	-13.7	1.55 H	130	55.8	4.5
2	5150.00	49.7 AV	54.0	-4.3	1.55 H	130	45.2	4.5
3	*5210.00	110.5 PK			1.55 H	130	106.2	4.3
4	*5210.00	99.5 AV			1.55 H	130	95.2	4.3
5	#10420.00	47.5 PK	68.2	-20.7	1.65 H	228	33.4	14.1
6	15630.00	58.6 PK	74.0	-15.4	1.62 H	34	44.3	14.3
7	15630.00	45.9 AV	54.0	-8.1	1.62 H	34	31.6	14.3

Remarks:

1. Emission Level(dBuV/m) = Raw Value(dBuV) + Correction Factor(dB/m)
2. Correction Factor(dB/m) = Antenna Factor(dB/m) + Cable Factor(dB) – Pre-Amplifier Factor(dB)
3. Margin value = Emission Level – Limit value
4. The other emission levels were very low against the limit.
5. " * ": Fundamental frequency, the limit was restricted at the RF Output Power.
6. " # ": The radiated frequency is out of the restricted band.

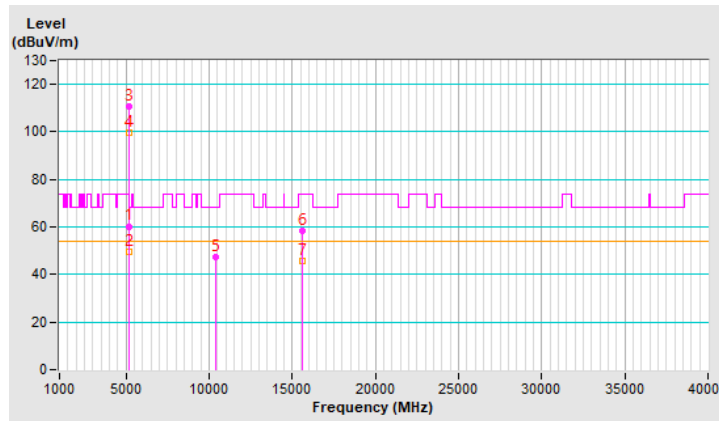

RF Mode	802.11ax (HE80)	Channel	CH 42 : 5210 MHz
Frequency Range	1 GHz ~ 40 GHz	Detector Function & Bandwidth	(PK) RB = 1 MHz, VB = 3 MHz (AV) RB = 1 MHz, VB = 10 Hz
Input Power	120 Vac, 60 Hz	Environmental Conditions	20°C, 70% RH
Tested By	Ryan Du		

Antenna Polarity & Test Distance : Vertical at 3 m								
No	Frequency (MHz)	Emission Level (dBuV/m)	Limit (dBuV/m)	Margin (dB)	Antenna Height (m)	Table Angle (Degree)	Raw Value (dBuV)	Correction Factor (dB/m)
1	5150.00	64.6 PK	74.0	-9.4	2.10 V	12	60.1	4.5
2	5150.00	53.8 AV	54.0	-0.2	2.10 V	12	49.3	4.5
3	*5210.00	111.7 PK			2.10 V	12	107.4	4.3
4	*5210.00	102.1 AV			2.10 V	12	97.8	4.3
5	#10420.00	48.2 PK	68.2	-20.0	1.79 V	205	34.1	14.1
6	15630.00	59.0 PK	74.0	-15.0	1.65 V	178	44.7	14.3
7	15630.00	46.5 AV	54.0	-7.5	1.65 V	178	32.2	14.3

Remarks:

1. Emission Level(dBuV/m) = Raw Value(dBuV) + Correction Factor(dB/m)
2. Correction Factor(dB/m) = Antenna Factor(dB/m) + Cable Factor(dB) – Pre-Amplifier Factor(dB)
3. Margin value = Emission Level – Limit value
4. The other emission levels were very low against the limit.
5. " * ": Fundamental frequency, the limit was restricted at the RF Output Power.
6. " # ": The radiated frequency is out of the restricted band.

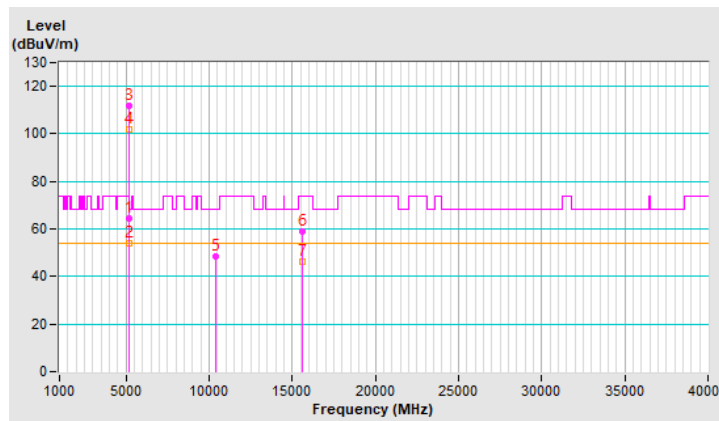

RF Mode	802.11ax (HE80)	Channel	CH 58 : 5290 MHz
Frequency Range	1 GHz ~ 40 GHz	Detector Function & Bandwidth	(PK) RB = 1 MHz, VB = 3 MHz (AV) RB = 1 MHz, VB = 10 Hz
Input Power	120 Vac, 60 Hz	Environmental Conditions	20°C, 70% RH
Tested By	Ryan Du		

Antenna Polarity & Test Distance : Horizontal at 3 m

No	Frequency (MHz)	Emission Level (dBuV/m)	Limit (dBuV/m)	Margin (dB)	Antenna Height (m)	Table Angle (Degree)	Raw Value (dBuV)	Correction Factor (dB/m)
1	*5290.00	108.5 PK			1.45 H	150	104.5	4.0
2	*5290.00	98.2 AV			1.45 H	150	94.2	4.0
3	5350.00	56.8 PK	74.0	-17.2	1.45 H	150	52.6	4.2
4	5350.00	50.2 AV	54.0	-3.8	1.45 H	150	46.0	4.2
5	#10580.00	47.3 PK	68.2	-20.9	1.73 H	222	33.5	13.8
6	15870.00	58.5 PK	74.0	-15.5	1.64 H	51	44.0	14.5
7	15870.00	45.9 AV	54.0	-8.1	1.64 H	51	31.4	14.5

Remarks:

1. Emission Level(dBuV/m) = Raw Value(dBuV) + Correction Factor(dB/m)
2. Correction Factor(dB/m) = Antenna Factor(dB/m) + Cable Factor(dB) – Pre-Amplifier Factor(dB)
3. Margin value = Emission Level – Limit value
4. The other emission levels were very low against the limit.
5. " * " : Fundamental frequency, the limit was restricted at the RF Output Power.
6. " # " : The radiated frequency is out of the restricted band.

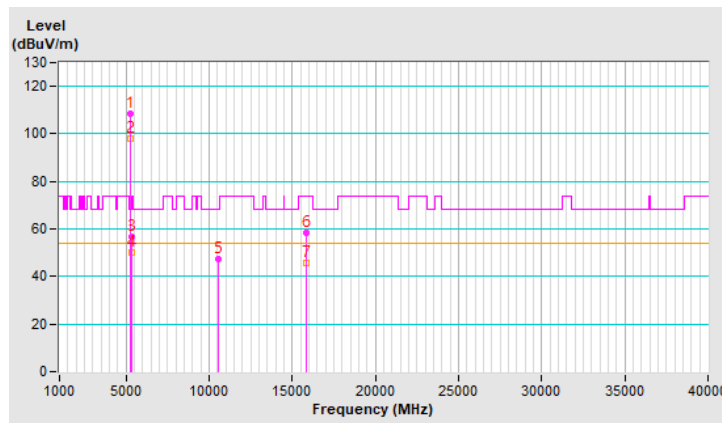

RF Mode	802.11ax (HE80)	Channel	CH 58 : 5290 MHz
Frequency Range	1 GHz ~ 40 GHz	Detector Function & Bandwidth	(PK) RB = 1 MHz, VB = 3 MHz (AV) RB = 1 MHz, VB = 10 Hz
Input Power	120 Vac, 60 Hz	Environmental Conditions	20°C, 70% RH
Tested By	Ryan Du		

Antenna Polarity & Test Distance : Vertical at 3 m								
No	Frequency (MHz)	Emission Level (dBuV/m)	Limit (dBuV/m)	Margin (dB)	Antenna Height (m)	Table Angle (Degree)	Raw Value (dBuV)	Correction Factor (dB/m)
1	*5290.00	112.1 PK			1.94 V	11	108.1	4.0
2	*5290.00	101.3 AV			1.94 V	11	97.3	4.0
3	5350.00	63.4 PK	74.0	-10.6	1.94 V	11	59.2	4.2
4	5350.00	53.7 AV	54.0	-0.3	1.94 V	11	49.5	4.2
5	#10580.00	48.3 PK	68.2	-19.9	1.73 V	204	34.5	13.8
6	15870.00	59.3 PK	74.0	-14.7	1.57 V	196	44.8	14.5
7	15870.00	46.7 AV	54.0	-7.3	1.57 V	196	32.2	14.5

Remarks:

1. Emission Level(dBuV/m) = Raw Value(dBuV) + Correction Factor(dB/m)
2. Correction Factor(dB/m) = Antenna Factor(dB/m) + Cable Factor(dB) – Pre-Amplifier Factor(dB)
3. Margin value = Emission Level – Limit value
4. The other emission levels were very low against the limit.
5. " * " : Fundamental frequency, the limit was restricted at the RF Output Power.
6. " # " : The radiated frequency is out of the restricted band.

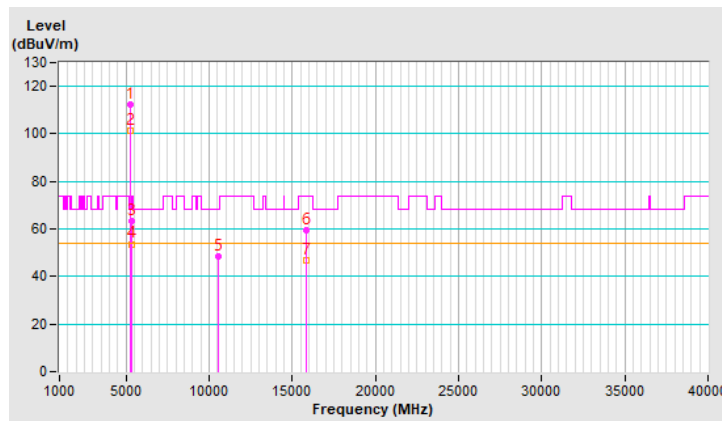

RF Mode	802.11ax (HE80)	Channel	CH 106 : 5530 MHz
Frequency Range	1 GHz ~ 40 GHz	Detector Function & Bandwidth	(PK) RB = 1 MHz, VB = 3 MHz (AV) RB = 1 MHz, VB = 10 Hz
Input Power	120 Vac, 60 Hz	Environmental Conditions	20°C, 70% RH
Tested By	Ryan Du		

Antenna Polarity & Test Distance : Horizontal at 3 m

No	Frequency (MHz)	Emission Level (dBuV/m)	Limit (dBuV/m)	Margin (dB)	Antenna Height (m)	Table Angle (Degree)	Raw Value (dBuV)	Correction Factor (dB/m)
1	5459.13	60.5 PK	74.0	-13.5	1.52 H	125	56.1	4.4
2	5459.13	49.4 AV	54.0	-4.6	1.52 H	125	45.0	4.4
3	#5470.00	62.1 PK	68.2	-6.1	1.52 H	125	57.7	4.4
4	*5530.00	111.4 PK			1.52 H	125	107.0	4.4
5	*5530.00	100.1 AV			1.52 H	125	95.7	4.4
6	11060.00	47.9 PK	74.0	-26.1	1.72 H	216	33.7	14.2
7	11060.00	36.8 AV	54.0	-17.2	1.72 H	216	22.6	14.2
8	#16590.00	58.8 PK	68.2	-9.4	1.57 H	38	41.6	17.2

Remarks:

1. Emission Level(dBuV/m) = Raw Value(dBuV) + Correction Factor(dB/m)
2. Correction Factor(dB/m) = Antenna Factor(dB/m) + Cable Factor(dB) – Pre-Amplifier Factor(dB)
3. Margin value = Emission Level – Limit value
4. The other emission levels were very low against the limit.
5. " * " : Fundamental frequency, the limit was restricted at the RF Output Power.
6. " # " : The radiated frequency is out of the restricted band.

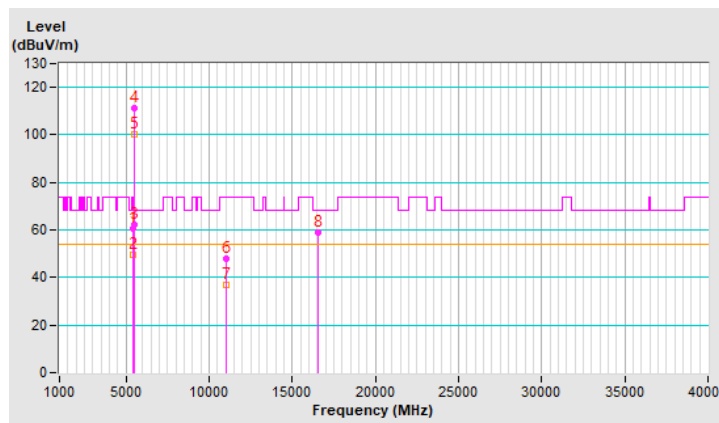

RF Mode	802.11ax (HE80)	Channel	CH 106 : 5530 MHz
Frequency Range	1 GHz ~ 40 GHz	Detector Function & Bandwidth	(PK) RB = 1 MHz, VB = 3 MHz (AV) RB = 1 MHz, VB = 10 Hz
Input Power	120 Vac, 60 Hz	Environmental Conditions	20°C, 70% RH
Tested By	Ryan Du		

Antenna Polarity & Test Distance : Vertical at 3 m								
No	Frequency (MHz)	Emission Level (dBuV/m)	Limit (dBuV/m)	Margin (dB)	Antenna Height (m)	Table Angle (Degree)	Raw Value (dBuV)	Correction Factor (dB/m)
1	5460.00	63.8 PK	74.0	-10.2	2.08 V	14	59.4	4.4
2	5460.00	53.9 AV	54.0	-0.1	2.08 V	14	49.5	4.4
3	#5467.71	65.7 PK	68.2	-2.5	2.08 V	14	61.3	4.4
4	*5530.00	113.8 PK			2.08 V	14	109.4	4.4
5	*5530.00	103.3 AV			2.08 V	14	98.9	4.4
6	11060.00	47.9 PK	74.0	-26.1	1.75 V	205	33.7	14.2
7	11060.00	36.8 AV	54.0	-17.2	1.75 V	205	22.6	14.2
8	#16590.00	59.6 PK	68.2	-8.6	1.54 V	201	42.4	17.2

Remarks:

1. Emission Level(dBuV/m) = Raw Value(dBuV) + Correction Factor(dB/m)
2. Correction Factor(dB/m) = Antenna Factor(dB/m) + Cable Factor(dB) – Pre-Amplifier Factor(dB)
3. Margin value = Emission Level – Limit value
4. The other emission levels were very low against the limit.
5. " * " : Fundamental frequency, the limit was restricted at the RF Output Power.
6. " # " : The radiated frequency is out of the restricted band.

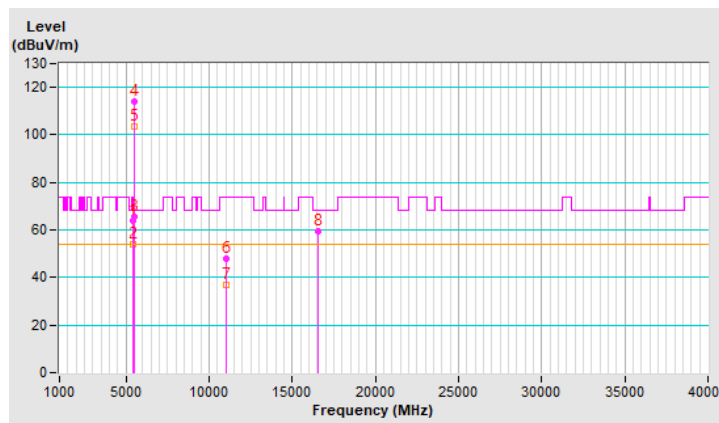

RF Mode	802.11ax (HE80)	Channel	CH 122 : 5610 MHz
Frequency Range	1 GHz ~ 40 GHz	Detector Function & Bandwidth	(PK) RB = 1 MHz, VB = 3 MHz (AV) RB = 1 MHz, VB = 10 Hz
Input Power	120 Vac, 60 Hz	Environmental Conditions	20°C, 70% RH
Tested By	Ryan Du		

Antenna Polarity & Test Distance : Horizontal at 3 m

No	Frequency (MHz)	Emission Level (dBuV/m)	Limit (dBuV/m)	Margin (dB)	Antenna Height (m)	Table Angle (Degree)	Raw Value (dBuV)	Correction Factor (dB/m)
1	5460.00	62.4 PK	74.0	-11.6	1.53 H	137	58.0	4.4
2	5460.00	50.2 AV	54.0	-3.8	1.53 H	137	45.8	4.4
3	#5460.57	64.3 PK	68.2	-3.9	1.53 H	137	59.9	4.4
4	*5610.00	113.3 PK			1.53 H	137	108.8	4.5
5	*5610.00	101.6 AV			1.53 H	137	97.1	4.5
6	#5737.48	64.8 PK	68.2	-3.4	1.53 H	137	60.2	4.6
7	11220.00	47.6 PK	74.0	-26.4	1.67 H	229	33.5	14.1
8	11220.00	36.9 AV	54.0	-17.1	1.67 H	229	22.8	14.1
9	#16830.00	58.0 PK	68.2	-10.2	1.60 H	35	39.6	18.4

Remarks:

1. Emission Level(dBuV/m) = Raw Value(dBuV) + Correction Factor(dB/m)
2. Correction Factor(dB/m) = Antenna Factor(dB/m) + Cable Factor(dB) – Pre-Amplifier Factor(dB)
3. Margin value = Emission Level – Limit value
4. The other emission levels were very low against the limit.
5. " * ": Fundamental frequency, the limit was restricted at the RF Output Power.
6. " # ": The radiated frequency is out of the restricted band.

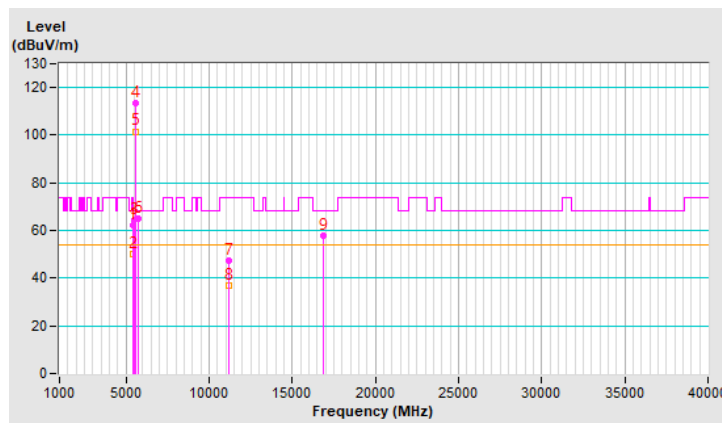

RF Mode	802.11ax (HE80)	Channel	CH 122 : 5610 MHz
Frequency Range	1 GHz ~ 40 GHz	Detector Function & Bandwidth	(PK) RB = 1 MHz, VB = 3 MHz (AV) RB = 1 MHz, VB = 10 Hz
Input Power	120 Vac, 60 Hz	Environmental Conditions	20°C, 70% RH
Tested By	Ryan Du		

Antenna Polarity & Test Distance : Vertical at 3 m

No	Frequency (MHz)	Emission Level (dBuV/m)	Limit (dBuV/m)	Margin (dB)	Antenna Height (m)	Table Angle (Degree)	Raw Value (dBuV)	Correction Factor (dB/m)
1	5460.00	65.9 PK	74.0	-8.1	2.18 V	14	61.5	4.4
2	5460.00	53.7 AV	54.0	-0.3	2.18 V	14	49.3	4.4
3	#5460.57	66.1 PK	68.2	-2.1	2.18 V	14	61.7	4.4
4	*5610.00	117.4 PK			2.18 V	14	112.9	4.5
5	*5610.00	105.7 AV			2.18 V	14	101.2	4.5
6	#5737.48	67.0 PK	68.2	-1.2	2.18 V	14	62.4	4.6
7	11220.00	47.8 PK	74.0	-26.2	1.76 V	207	33.7	14.1
8	11220.00	36.2 AV	54.0	-17.8	1.76 V	207	22.1	14.1
9	#16830.00	60.1 PK	68.2	-8.1	1.55 V	189	41.7	18.4

Remarks:

1. Emission Level(dBuV/m) = Raw Value(dBuV) + Correction Factor(dB/m)
2. Correction Factor(dB/m) = Antenna Factor(dB/m) + Cable Factor(dB) – Pre-Amplifier Factor(dB)
3. Margin value = Emission Level – Limit value
4. The other emission levels were very low against the limit.
5. " * ": Fundamental frequency, the limit was restricted at the RF Output Power.
6. " # ": The radiated frequency is out of the restricted band.

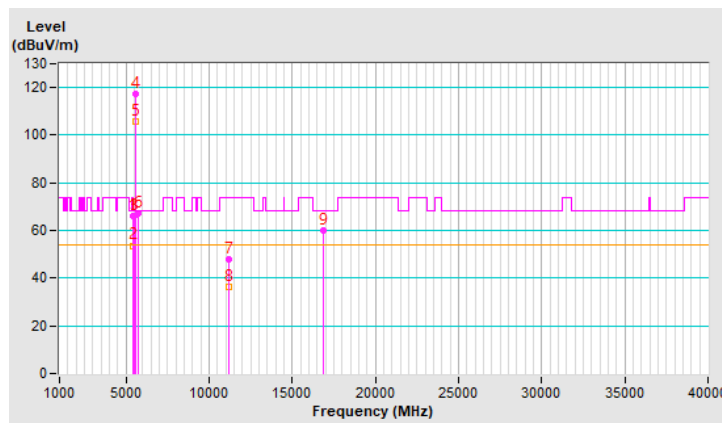

RF Mode	802.11ax (HE80)	Channel	CH 138 : 5690 MHz
Frequency Range	1 GHz ~ 40 GHz	Detector Function & Bandwidth	(PK) RB = 1 MHz, VB = 3 MHz (AV) RB = 1 MHz, VB = 10 Hz
Input Power	120 Vac, 60 Hz	Environmental Conditions	20°C, 70% RH
Tested By	Ryan Du		

Antenna Polarity & Test Distance : Horizontal at 3 m

No	Frequency (MHz)	Emission Level (dBuV/m)	Limit (dBuV/m)	Margin (dB)	Antenna Height (m)	Table Angle (Degree)	Raw Value (dBuV)	Correction Factor (dB/m)
1	5460.00	55.9 PK	74.0	-18.1	1.54 H	140	51.5	4.4
2	5460.00	45.1 AV	54.0	-8.9	1.54 H	140	40.7	4.4
3	#5470.00	56.5 PK	68.2	-11.7	1.54 H	140	52.1	4.4
4	*5690.00	112.5 PK			1.54 H	140	108.0	4.5
5	*5690.00	101.1 AV			1.54 H	140	96.6	4.5
6	#5850.00	65.0 PK	68.2	-3.2	1.54 H	140	59.9	5.1
7	11380.00	47.0 PK	74.0	-27.0	1.70 H	216	32.0	15.0
8	11380.00	35.9 AV	54.0	-18.1	1.70 H	216	20.9	15.0
9	#17070.00	58.2 PK	68.2	-10.0	1.57 H	35	39.0	19.2

Remarks:

1. Emission Level(dBuV/m) = Raw Value(dBuV) + Correction Factor(dB/m)
2. Correction Factor(dB/m) = Antenna Factor(dB/m) + Cable Factor(dB) – Pre-Amplifier Factor(dB)
3. Margin value = Emission Level – Limit value
4. The other emission levels were very low against the limit.
5. " * ": Fundamental frequency, the limit was restricted at the RF Output Power.
6. " # ": The radiated frequency is out of the restricted band.

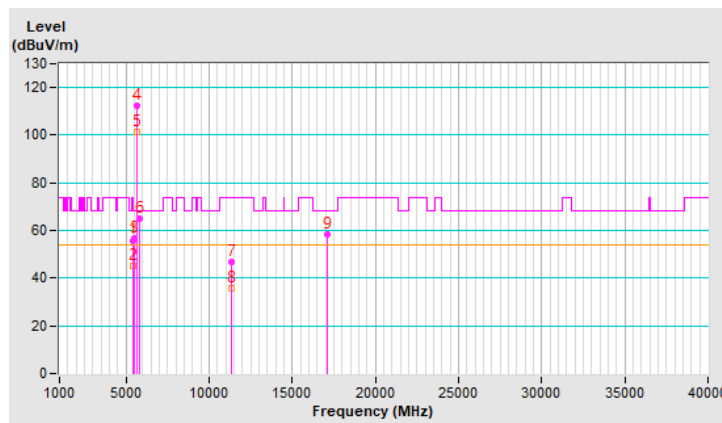

RF Mode	802.11ax (HE80)	Channel	CH 138 : 5690 MHz
Frequency Range	1 GHz ~ 40 GHz	Detector Function & Bandwidth	(PK) RB = 1 MHz, VB = 3 MHz (AV) RB = 1 MHz, VB = 10 Hz
Input Power	120 Vac, 60 Hz	Environmental Conditions	20°C, 70% RH
Tested By	Ryan Du		

Antenna Polarity & Test Distance : Vertical at 3 m								
No	Frequency (MHz)	Emission Level (dBuV/m)	Limit (dBuV/m)	Margin (dB)	Antenna Height (m)	Table Angle (Degree)	Raw Value (dBuV)	Correction Factor (dB/m)
1	5460.00	59.7 PK	74.0	-14.3	1.91 V	12	55.3	4.4
2	5460.00	48.6 AV	54.0	-5.4	1.91 V	12	44.2	4.4
3	#5470.00	61.1 PK	68.2	-7.1	1.91 V	12	56.7	4.4
4	*5690.00	118.3 PK			1.91 V	12	113.8	4.5
5	*5690.00	107.0 AV			1.91 V	12	102.5	4.5
6	#5852.23	67.7 PK	68.2	-0.5	1.91 V	12	62.6	5.1
7	11380.00	47.3 PK	74.0	-26.7	1.80 V	205	32.3	15.0
8	11380.00	36.2 AV	54.0	-17.8	1.80 V	205	21.2	15.0
9	#17070.00	59.2 PK	68.2	-9.0	1.55 V	201	40.0	19.2

Remarks:

1. Emission Level(dBuV/m) = Raw Value(dBuV) + Correction Factor(dB/m)
2. Correction Factor(dB/m) = Antenna Factor(dB/m) + Cable Factor(dB) – Pre-Amplifier Factor(dB)
3. Margin value = Emission Level – Limit value
4. The other emission levels were very low against the limit.
5. " * ": Fundamental frequency, the limit was restricted at the RF Output Power.
6. " # ": The radiated frequency is out of the restricted band.

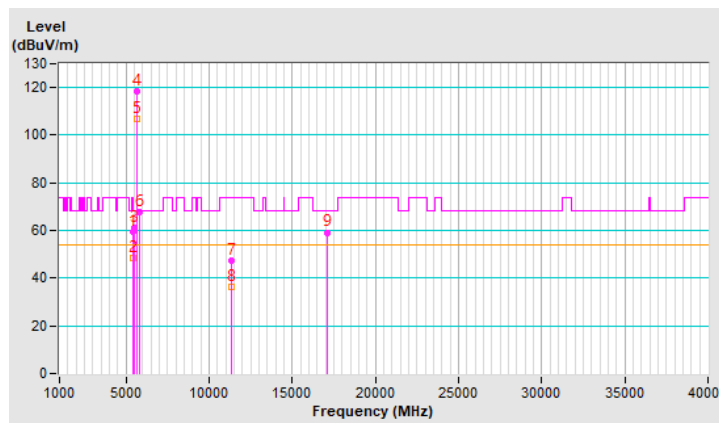

RF Mode	802.11ax (HE80)	Channel	CH 155 : 5775 MHz
Frequency Range	1 GHz ~ 40 GHz	Detector Function & Bandwidth	(PK) RB = 1 MHz, VB = 3 MHz (AV) RB = 1 MHz, VB = 10 Hz
Input Power	120 Vac, 60 Hz	Environmental Conditions	20°C, 70% RH
Tested By	Ryan Du		

Antenna Polarity & Test Distance : Horizontal at 3 m

No	Frequency (MHz)	Emission Level (dBuV/m)	Limit (dBuV/m)	Margin (dB)	Antenna Height (m)	Table Angle (Degree)	Raw Value (dBuV)	Correction Factor (dB/m)
1	#5643.14	63.0 PK	68.2	-5.2	1.46 H	154	58.3	4.7
2	*5775.00	112.8 PK			1.46 H	154	108.1	4.7
3	*5775.00	101.3 AV			1.46 H	154	96.6	4.7
4	#5928.55	57.2 PK	68.2	-11.0	1.46 H	154	52.1	5.1
5	11550.00	47.4 PK	74.0	-26.6	1.72 H	204	32.7	14.7
6	11550.00	36.3 AV	54.0	-17.7	1.72 H	204	21.6	14.7
7	#17325.00	58.7 PK	68.2	-9.5	1.63 H	44	40.2	18.5

Remarks:

1. Emission Level(dBuV/m) = Raw Value(dBuV) + Correction Factor(dB/m)
2. Correction Factor(dB/m) = Antenna Factor(dB/m) + Cable Factor(dB) – Pre-Amplifier Factor(dB)
3. Margin value = Emission Level – Limit value
4. The other emission levels were very low against the limit.
5. " * " : Fundamental frequency, the limit was restricted at the RF Output Power.
6. " # " : The radiated frequency is out of the restricted band.

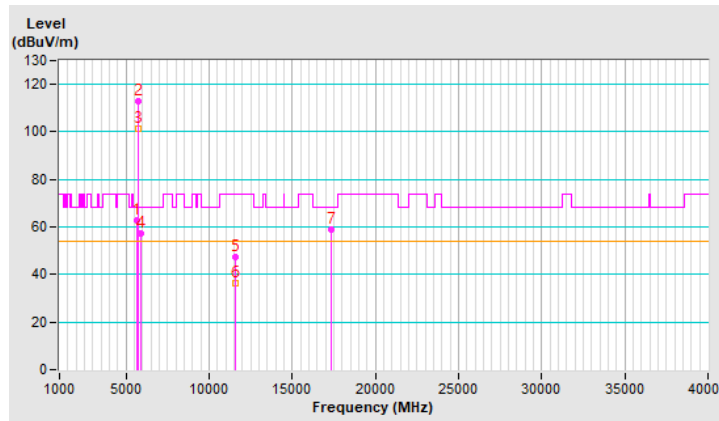

RF Mode	802.11ax (HE80)	Channel	CH 155 : 5775 MHz
Frequency Range	1 GHz ~ 40 GHz	Detector Function & Bandwidth	(PK) RB = 1 MHz, VB = 3 MHz (AV) RB = 1 MHz, VB = 10 Hz
Input Power	120 Vac, 60 Hz	Environmental Conditions	20°C, 70% RH
Tested By	Ryan Du		

Antenna Polarity & Test Distance : Vertical at 3 m								
No	Frequency (MHz)	Emission Level (dBuV/m)	Limit (dBuV/m)	Margin (dB)	Antenna Height (m)	Table Angle (Degree)	Raw Value (dBuV)	Correction Factor (dB/m)
1	#5638.92	67.8 PK	68.2	-0.4	1.90 V	11	63.2	4.6
2	*5775.00	117.0 PK			1.90 V	11	112.3	4.7
3	*5775.00	105.7 AV			1.90 V	11	101.0	4.7
4	#5927.91	61.5 PK	68.2	-6.7	1.90 V	11	56.4	5.1
5	11550.00	47.7 PK	74.0	-26.3	1.74 V	202	33.0	14.7
6	11550.00	36.3 AV	54.0	-17.7	1.74 V	202	21.6	14.7
7	#17325.00	59.7 PK	68.2	-8.5	1.64 V	188	41.2	18.5

Remarks:

1. Emission Level(dBuV/m) = Raw Value(dBuV) + Correction Factor(dB/m)
2. Correction Factor(dB/m) = Antenna Factor(dB/m) + Cable Factor(dB) – Pre-Amplifier Factor(dB)
3. Margin value = Emission Level – Limit value
4. The other emission levels were very low against the limit.
5. " * " : Fundamental frequency, the limit was restricted at the RF Output Power.
6. " # " : The radiated frequency is out of the restricted band.

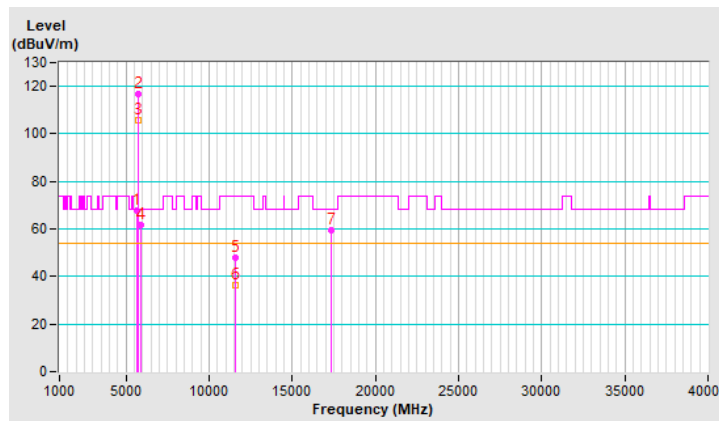

RF Mode	802.11ax (HE160)	Channel	CH 50 : 5250 MHz
Frequency Range	1 GHz ~ 40 GHz	Detector Function & Bandwidth	(PK) RB = 1 MHz, VB = 3 MHz (AV) RB = 1 MHz, VB = 10 Hz
Input Power	120 Vac, 60 Hz	Environmental Conditions	20°C, 70% RH
Tested By	Ryan Du		

Antenna Polarity & Test Distance : Horizontal at 3 m

No	Frequency (MHz)	Emission Level (dBuV/m)	Limit (dBuV/m)	Margin (dB)	Antenna Height (m)	Table Angle (Degree)	Raw Value (dBuV)	Correction Factor (dB/m)
1	5150.00	61.3 PK	74.0	-12.7	1.44 H	138	56.8	4.5
2	5150.00	49.1 AV	54.0	-4.9	1.44 H	138	44.6	4.5
3	*5250.00	106.4 PK			1.44 H	138	102.4	4.0
4	*5250.00	94.8 AV			1.44 H	138	90.8	4.0
5	5416.57	63.0 PK	74.0	-11.0	1.44 H	138	58.7	4.3
6	5416.57	50.9 AV	54.0	-3.1	1.44 H	138	46.6	4.3
7	#10500.00	47.3 PK	68.2	-20.9	1.71 H	228	33.1	14.2
8	15750.00	58.1 PK	74.0	-15.9	1.58 H	46	43.7	14.4
9	15750.00	45.5 AV	54.0	-8.5	1.58 H	46	31.1	14.4

Remarks:

1. Emission Level(dBuV/m) = Raw Value(dBuV) + Correction Factor(dB/m)
2. Correction Factor(dB/m) = Antenna Factor(dB/m) + Cable Factor(dB) – Pre-Amplifier Factor(dB)
3. Margin value = Emission Level – Limit value
4. The other emission levels were very low against the limit.
5. " * " : Fundamental frequency, the limit was restricted at the RF Output Power.
6. " # " : The radiated frequency is out of the restricted band.

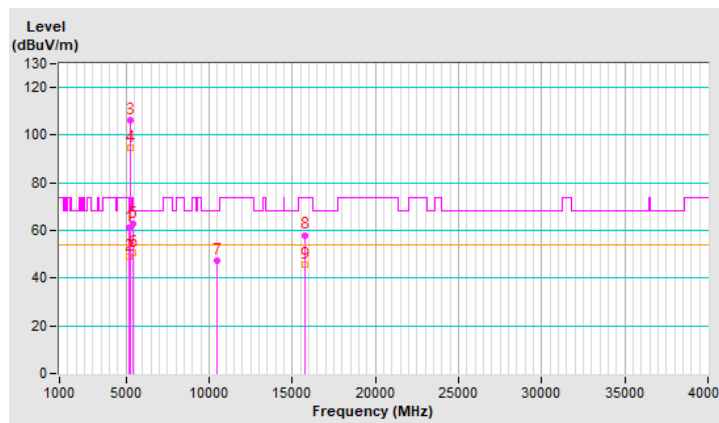

RF Mode	802.11ax (HE160)	Channel	CH 50 : 5250 MHz
Frequency Range	1 GHz ~ 40 GHz	Detector Function & Bandwidth	(PK) RB = 1 MHz, VB = 3 MHz (AV) RB = 1 MHz, VB = 10 Hz
Input Power	120 Vac, 60 Hz	Environmental Conditions	20°C, 70% RH
Tested By	Ryan Du		

Antenna Polarity & Test Distance : Vertical at 3 m								
No	Frequency (MHz)	Emission Level (dBuV/m)	Limit (dBuV/m)	Margin (dB)	Antenna Height (m)	Table Angle (Degree)	Raw Value (dBuV)	Correction Factor (dB/m)
1	5150.00	65.2 PK	74.0	-8.8	1.10 V	11	60.7	4.5
2	5150.00	49.8 AV	54.0	-4.2	1.10 V	11	45.3	4.5
3	*5250.00	109.5 PK			1.10 V	11	105.5	4.0
4	*5250.00	97.6 AV			1.10 V	11	93.6	4.0
5	5350.00	67.7 PK	74.0	-6.3	1.10 V	11	63.5	4.2
6	5350.00	53.6 AV	54.0	-0.4	1.10 V	11	49.4	4.2
7	5395.20	72.5 PK	74.0	-1.5	1.10 V	11	68.2	4.3
8	5395.20	52.3 AV	54.0	-1.7	1.10 V	11	48.0	4.3
9	#10500.00	48.4 PK	68.2	-19.8	1.73 V	214	34.2	14.2
10	15750.00	59.2 PK	74.0	-14.8	1.62 V	194	44.8	14.4
11	15750.00	46.6 AV	54.0	-7.4	1.62 V	194	32.2	14.4

Remarks:

1. Emission Level(dBuV/m) = Raw Value(dBuV) + Correction Factor(dB/m)
2. Correction Factor(dB/m) = Antenna Factor(dB/m) + Cable Factor(dB) – Pre-Amplifier Factor(dB)
3. Margin value = Emission Level – Limit value
4. The other emission levels were very low against the limit.
5. " * " : Fundamental frequency, the limit was restricted at the RF Output Power.
6. " # " : The radiated frequency is out of the restricted band.

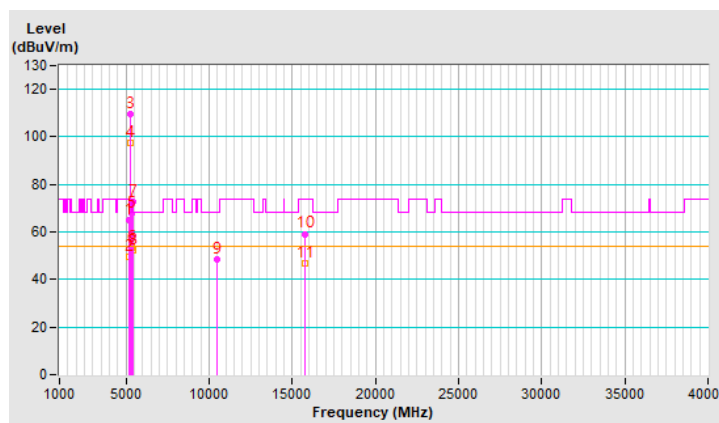

RF Mode	802.11ax (HE160)	Channel	CH 114 : 5570 MHz
Frequency Range	1 GHz ~ 40 GHz	Detector Function & Bandwidth	(PK) RB = 1 MHz, VB = 3 MHz (AV) RB = 1 MHz, VB = 10 Hz
Input Power	120 Vac, 60 Hz	Environmental Conditions	20°C, 70% RH
Tested By	Ryan Du		

Antenna Polarity & Test Distance : Horizontal at 3 m

No	Frequency (MHz)	Emission Level (dBuV/m)	Limit (dBuV/m)	Margin (dB)	Antenna Height (m)	Table Angle (Degree)	Raw Value (dBuV)	Correction Factor (dB/m)
1	5422.51	62.5 PK	74.0	-11.5	1.45 H	135	58.2	4.3
2	5422.51	50.7 AV	54.0	-3.3	1.45 H	135	46.4	4.3
3	#5469.64	65.8 PK	68.2	-2.4	1.45 H	135	61.4	4.4
4	*5570.00	106.4 PK			1.45 H	135	102.0	4.4
5	*5570.00	95.0 AV			1.45 H	135	90.6	4.4
6	#5761.32	59.5 PK	68.2	-8.7	1.45 H	135	54.9	4.6
7	11140.00	47.6 PK	74.0	-26.4	1.68 H	224	33.6	14.0
8	11140.00	36.5 AV	54.0	-17.5	1.68 H	224	22.5	14.0
9	#16710.00	58.4 PK	68.2	-9.8	1.58 H	41	40.1	18.3

Remarks:

1. Emission Level(dBuV/m) = Raw Value(dBuV) + Correction Factor(dB/m)
2. Correction Factor(dB/m) = Antenna Factor(dB/m) + Cable Factor(dB) – Pre-Amplifier Factor(dB)
3. Margin value = Emission Level – Limit value
4. The other emission levels were very low against the limit.
5. " * ": Fundamental frequency, the limit was restricted at the RF Output Power.
6. " # ": The radiated frequency is out of the restricted band.

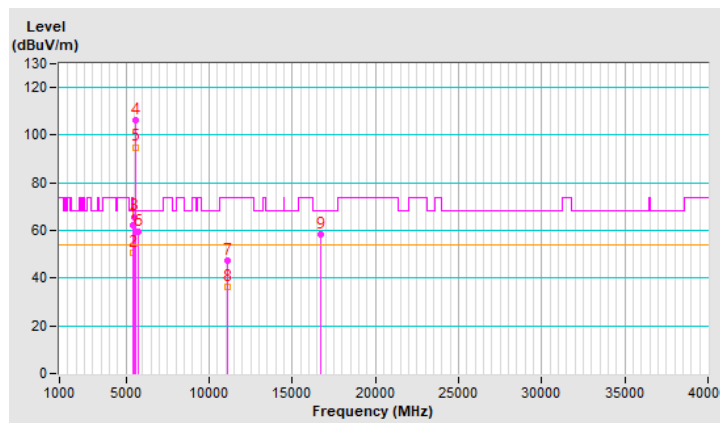

RF Mode	802.11ax (HE160)	Channel	CH 114 : 5570 MHz
Frequency Range	1 GHz ~ 40 GHz	Detector Function & Bandwidth	(PK) RB = 1 MHz, VB = 3 MHz (AV) RB = 1 MHz, VB = 10 Hz
Input Power	120 Vac, 60 Hz	Environmental Conditions	20°C, 70% RH
Tested By	Ryan Du		

Antenna Polarity & Test Distance : Vertical at 3 m								
No	Frequency (MHz)	Emission Level (dBuV/m)	Limit (dBuV/m)	Margin (dB)	Antenna Height (m)	Table Angle (Degree)	Raw Value (dBuV)	Correction Factor (dB/m)
1	5424.85	64.5 PK	74.0	-9.5	2.00 V	198	60.2	4.3
2	5424.85	53.7 AV	54.0	-0.3	2.00 V	198	49.4	4.3
3	#5461.00	67.8 PK	68.2	-0.4	2.00 V	198	63.4	4.4
4	*5570.00	108.8 PK			2.00 V	198	104.4	4.4
5	*5570.00	97.4 AV			2.00 V	198	93.0	4.4
6	#5751.04	66.3 PK	68.2	-1.9	2.00 V	198	61.8	4.5
7	11140.00	48.1 PK	74.0	-25.9	1.73 V	205	34.1	14.0
8	11140.00	36.9 AV	54.0	-17.1	1.73 V	205	22.9	14.0
9	#16710.00	59.5 PK	68.2	-8.7	1.64 V	198	41.2	18.3

Remarks:

1. Emission Level(dBuV/m) = Raw Value(dBuV) + Correction Factor(dB/m)
2. Correction Factor(dB/m) = Antenna Factor(dB/m) + Cable Factor(dB) – Pre-Amplifier Factor(dB)
3. Margin value = Emission Level – Limit value
4. The other emission levels were very low against the limit.
5. " * ": Fundamental frequency, the limit was restricted at the RF Output Power.
6. " # ": The radiated frequency is out of the restricted band.

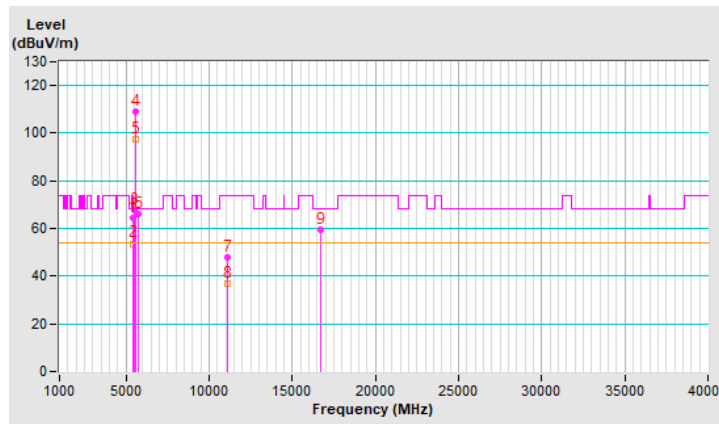

Plot of Band Edge

802.11a Channel 36

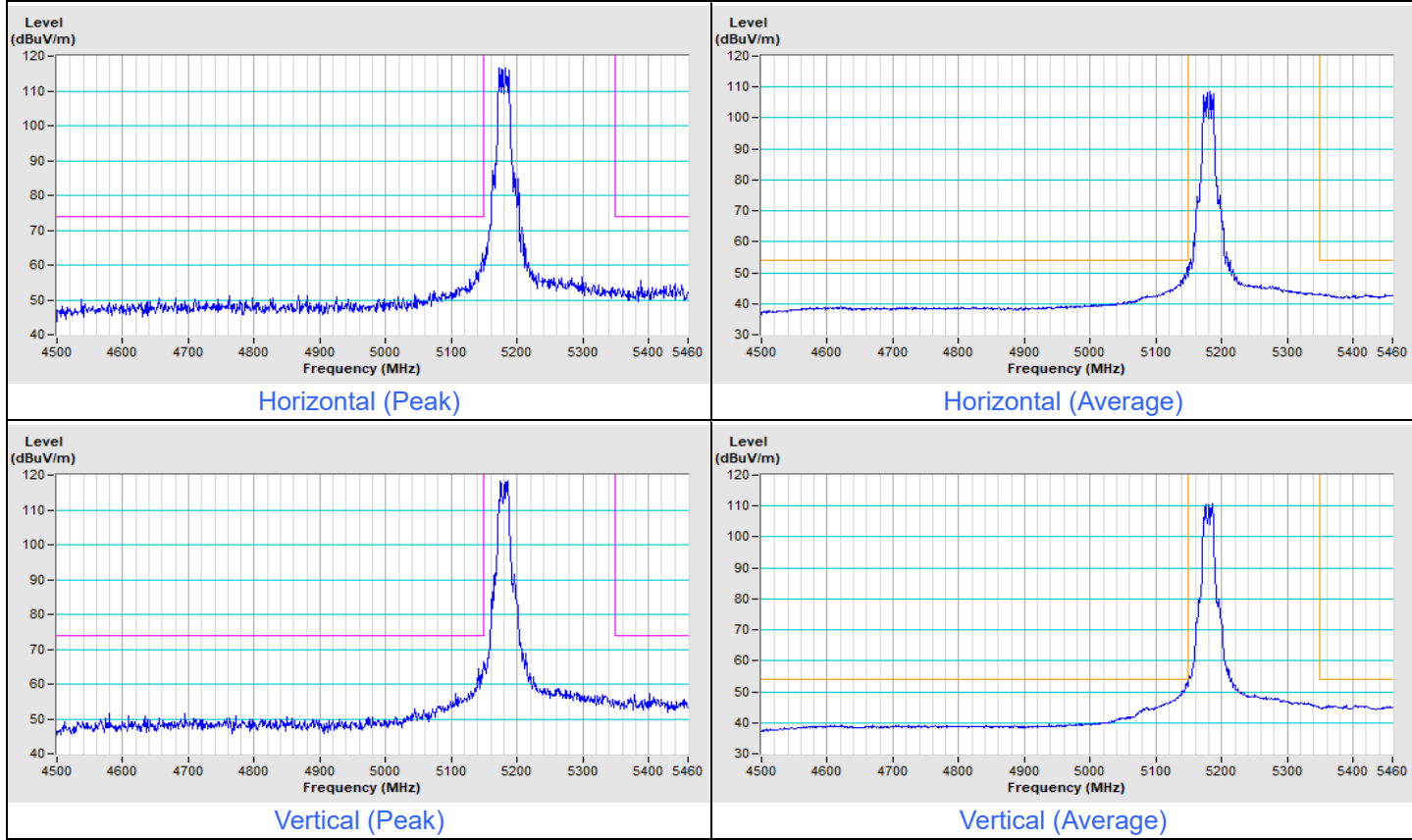

802.11a Channel 64

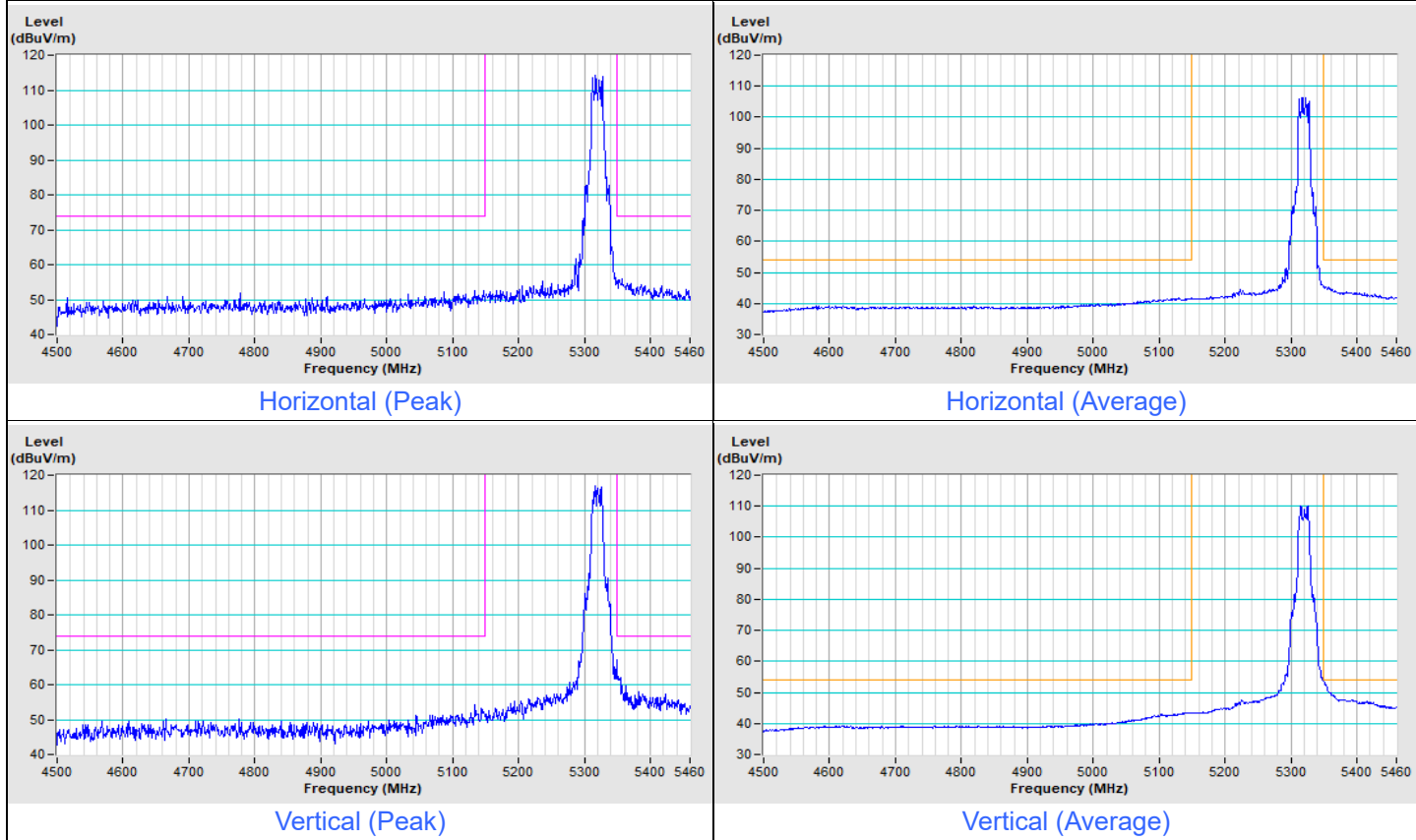

802.11a Channel 100

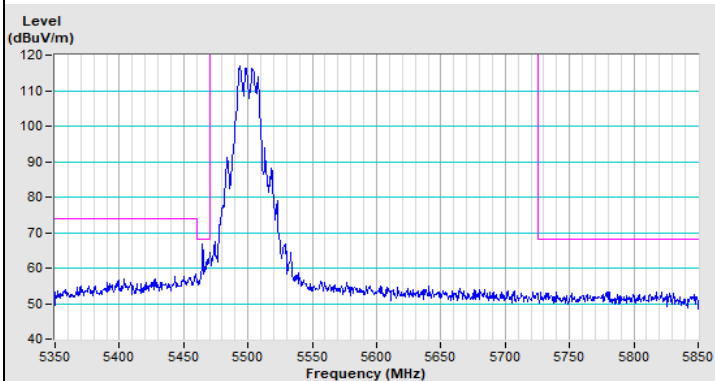

Horizontal (Peak)

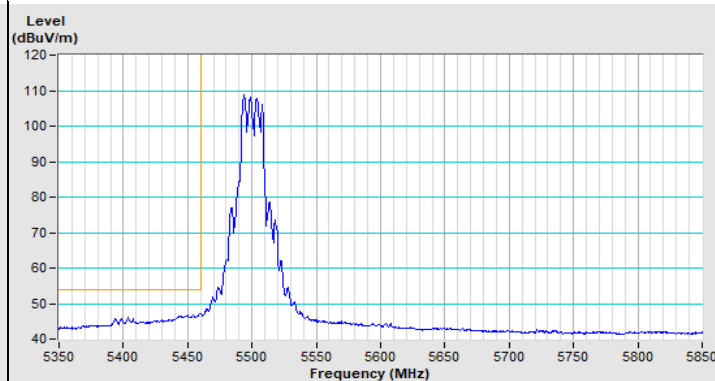

Horizontal (Average)

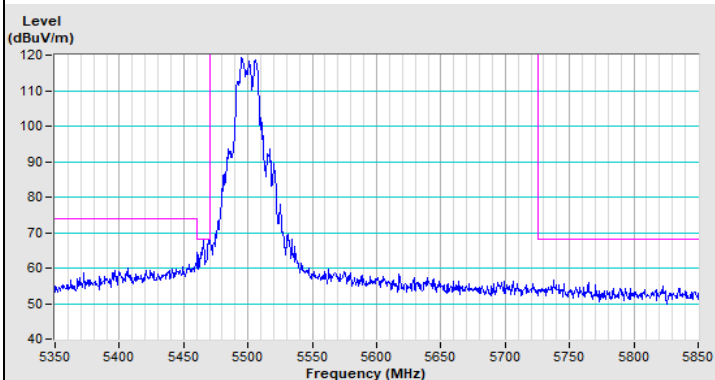

Vertical (Peak)

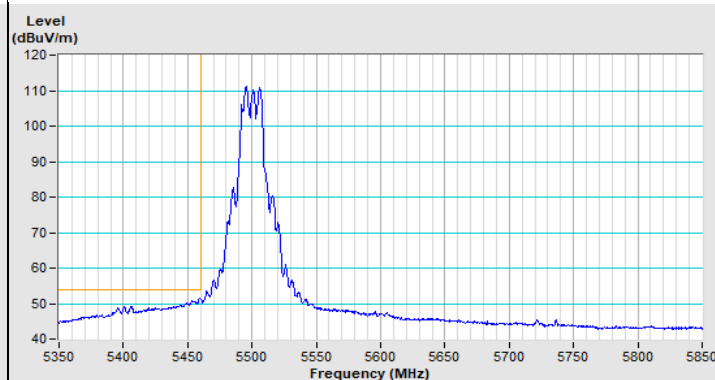

Vertical (Average)

802.11a Channel 149

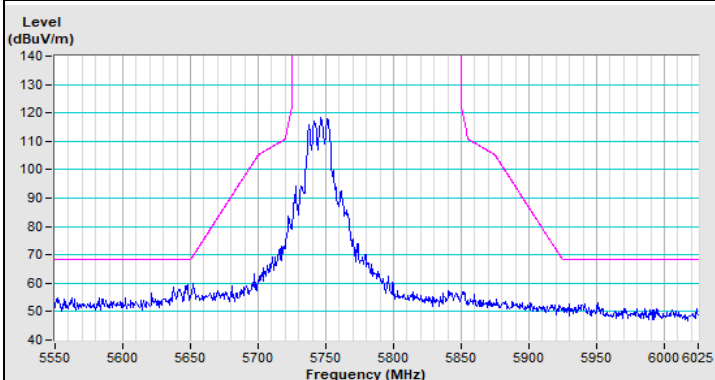

Horizontal (Peak)

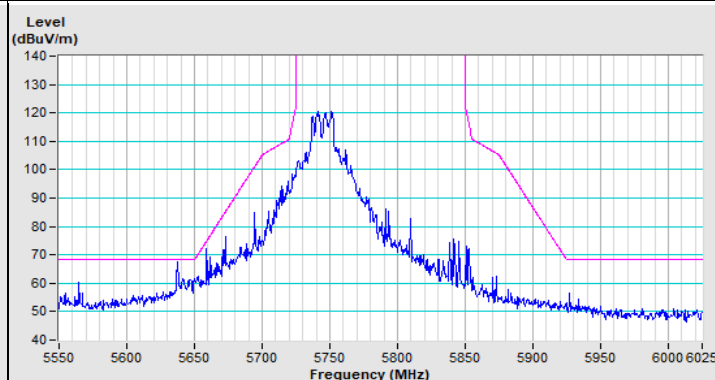

Vertical (Peak)

802.11a Channel 157

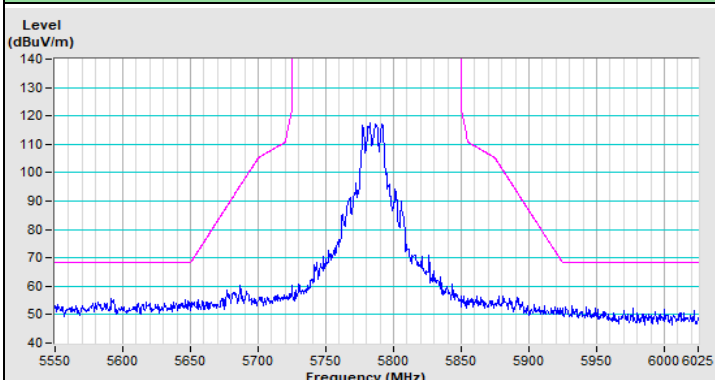

Horizontal (Peak)

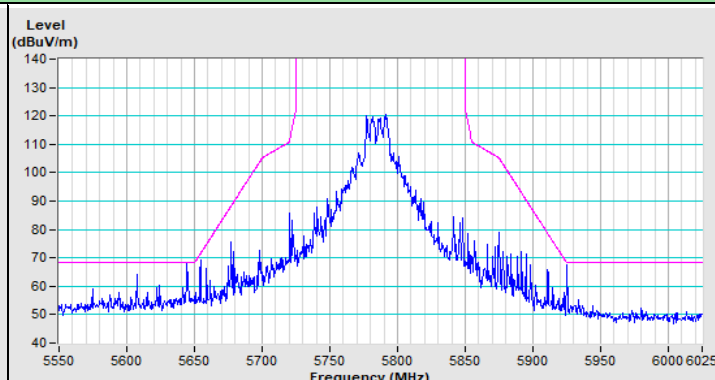

Vertical (Peak)

802.11a Channel 165

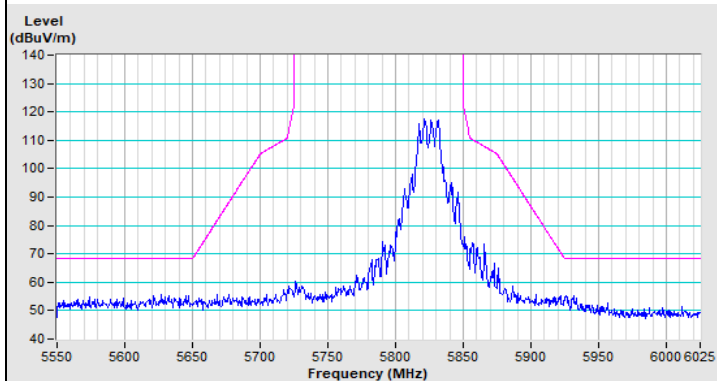

Horizontal (Peak)

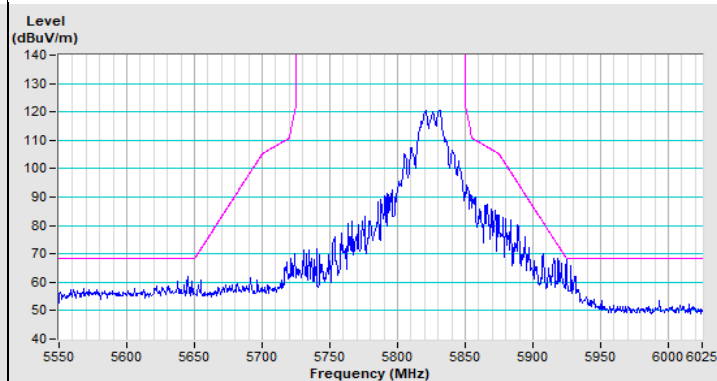

Vertical (Peak)

802.11ax (HE20) Channel 36

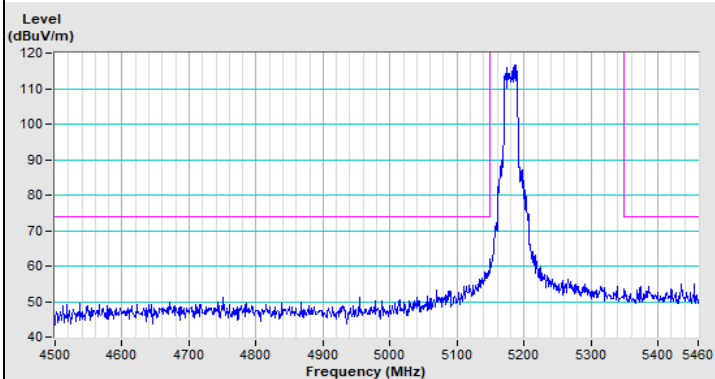

Horizontal (Peak)

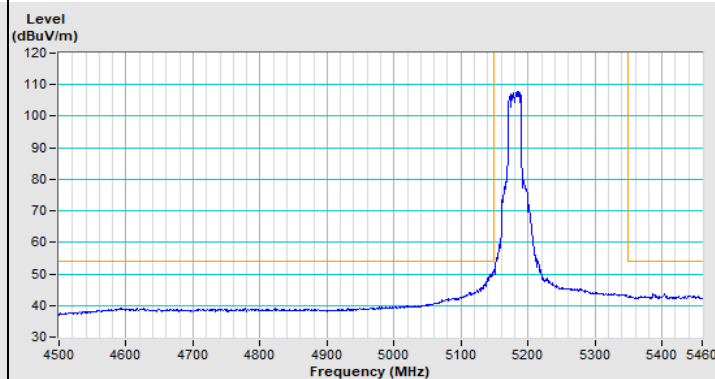

Horizontal (Average)

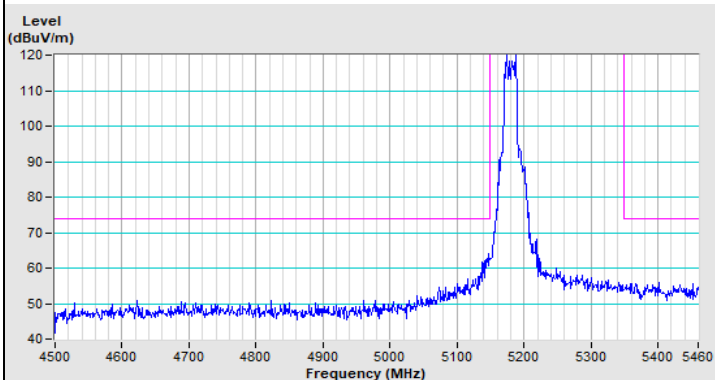

Vertical (Peak)

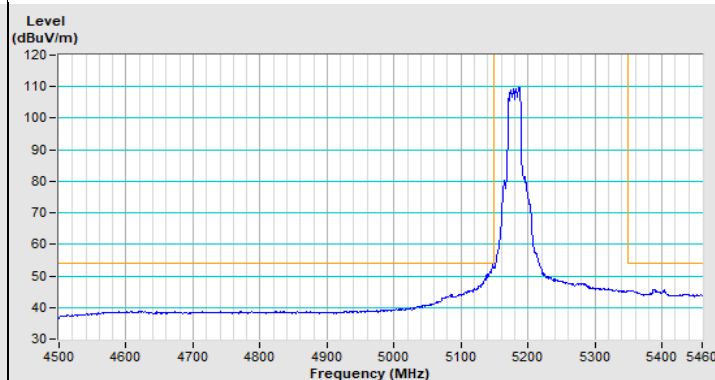

Vertical (Average)

802.11ax (HE20) Channel 64

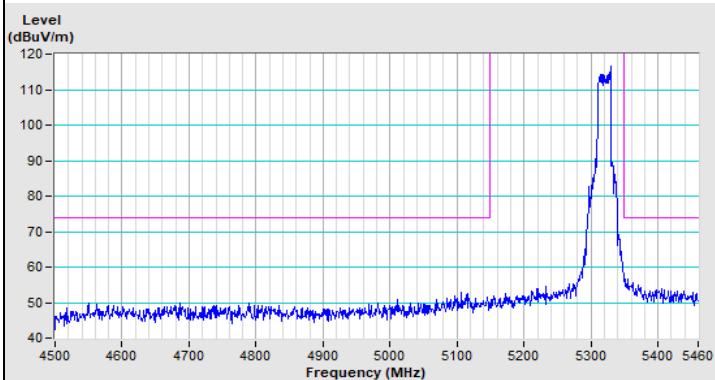

Horizontal (Peak)

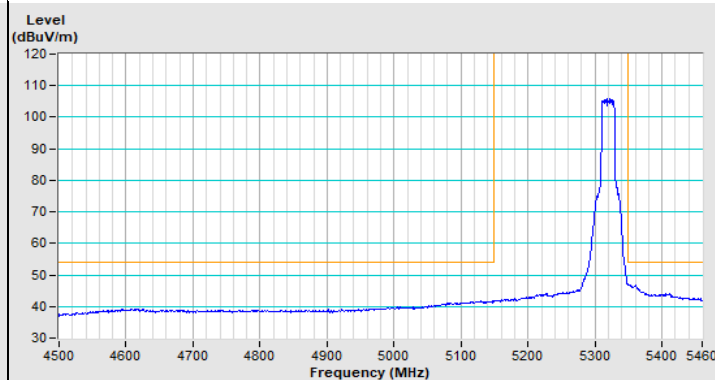

Horizontal (Average)

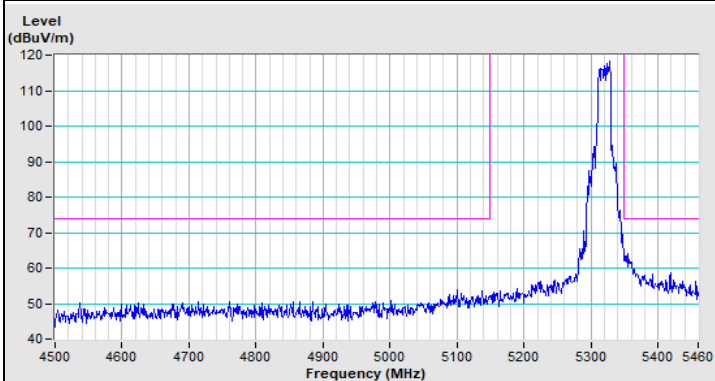

Vertical (Peak)

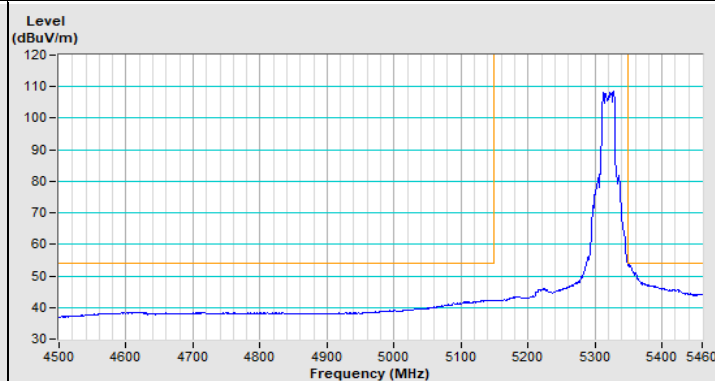

Vertical (Average)

802.11ax (HE20) Channel 100

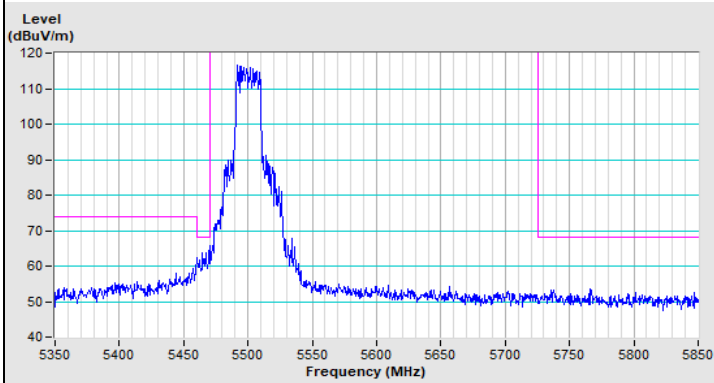

Horizontal (Peak)

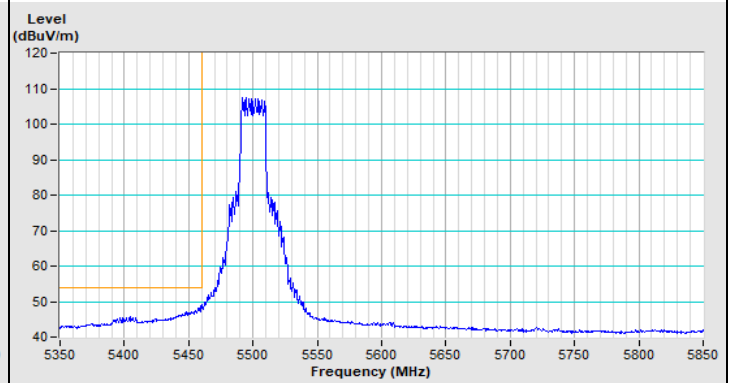

Horizontal (Average)

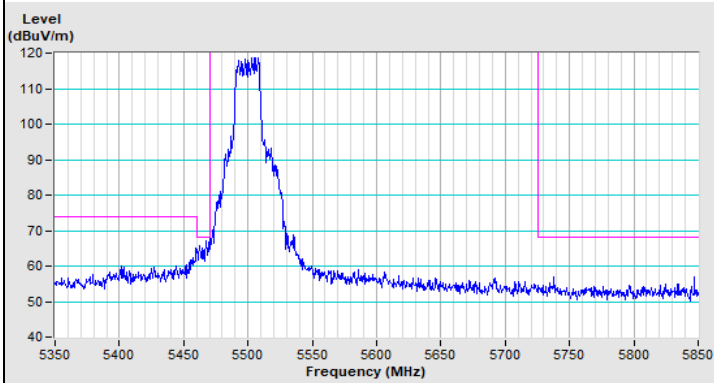

Vertical (Peak)

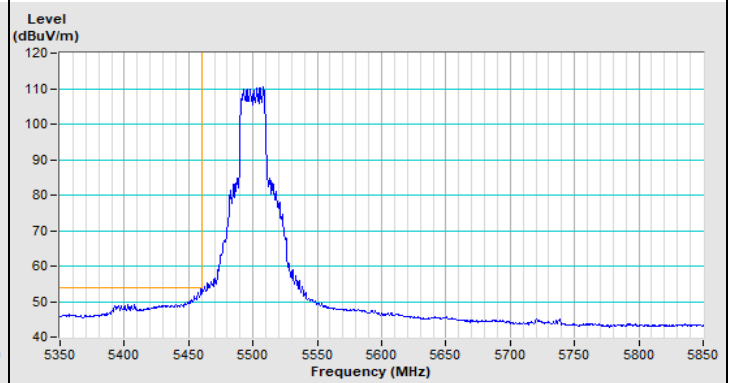

Vertical (Average)

802.11ax (HE20) Channel 149

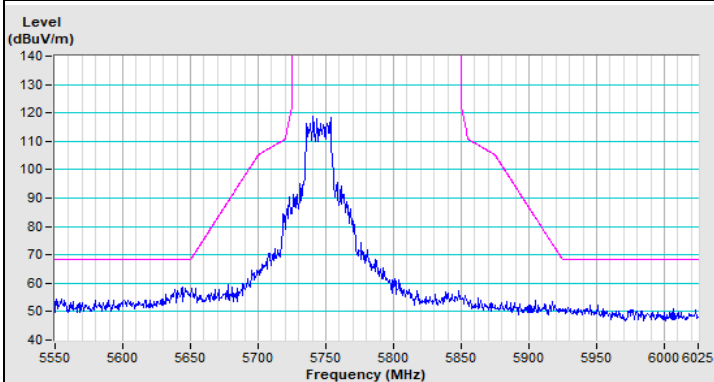

Horizontal (Peak)

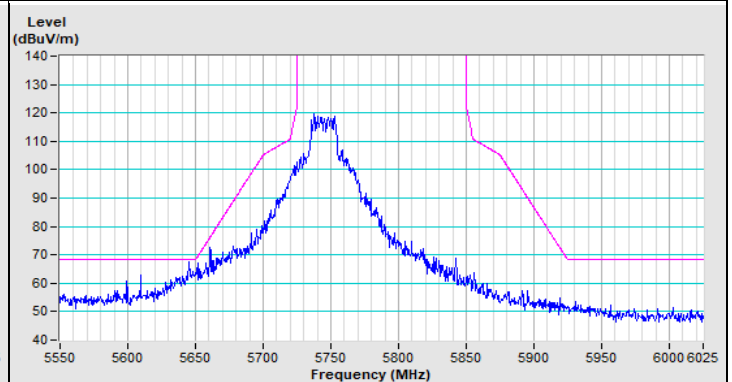

Vertical (Peak)

802.11ax (HE20) Channel 157

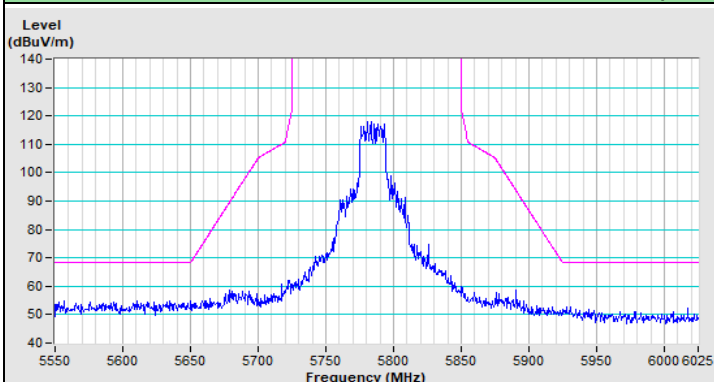

Horizontal (Peak)

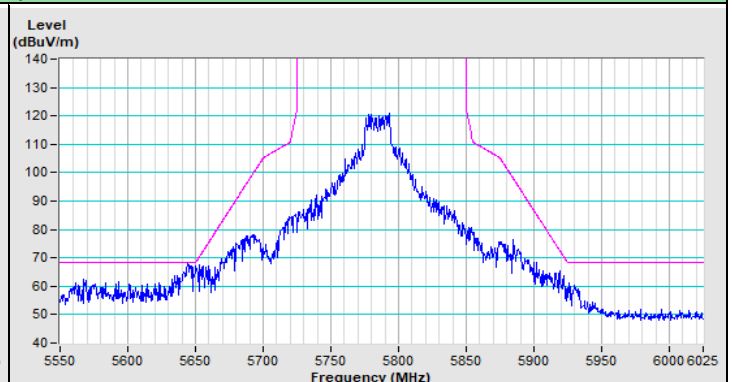

Vertical (Peak)

802.11ax (HE20) Channel 165

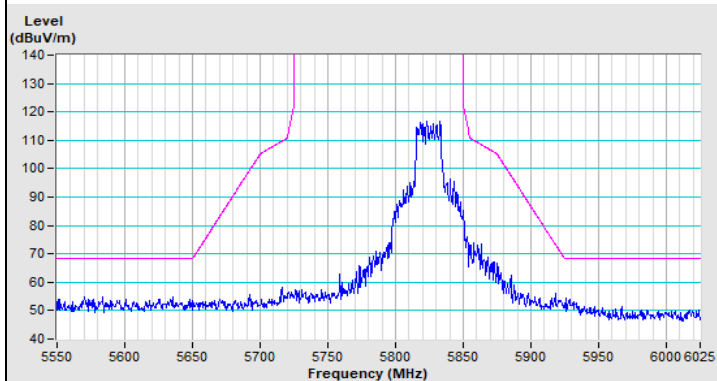

Horizontal (Peak)

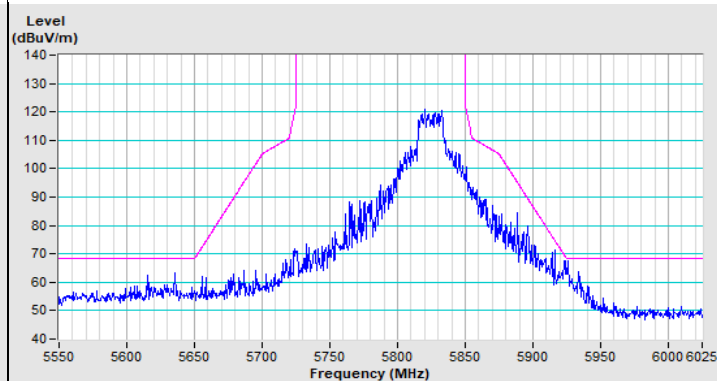

Vertical (Peak)

802.11ax (HE40) Channel 38

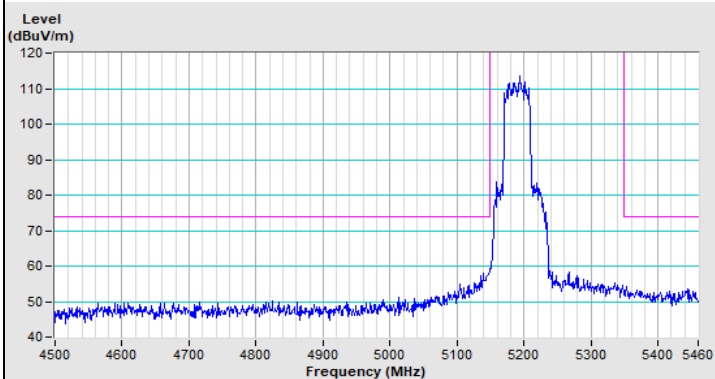

Horizontal (Peak)

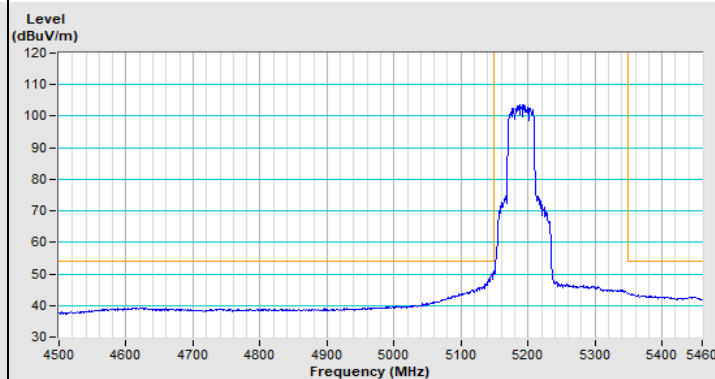

Horizontal (Average)

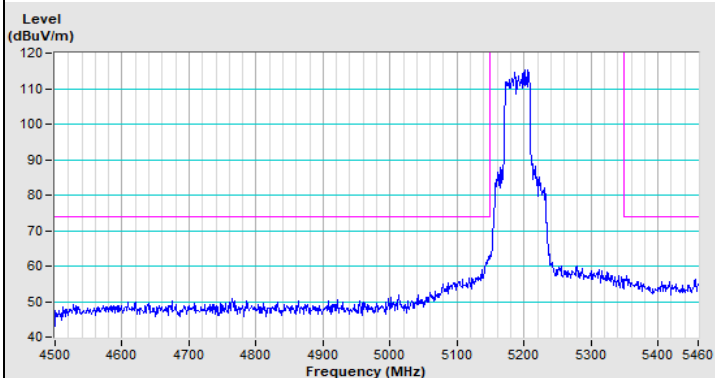

Vertical (Peak)

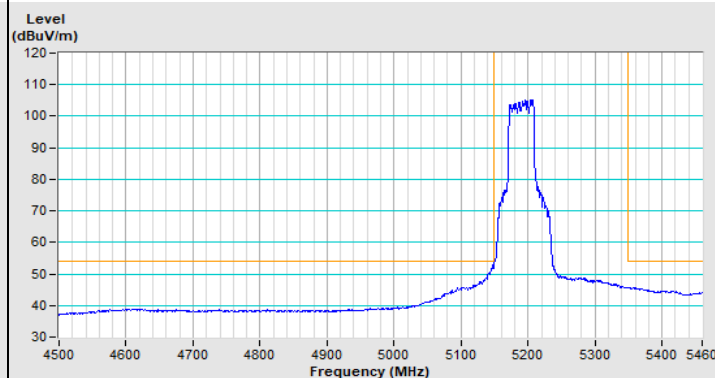

Vertical (Average)

802.11ax (HE40) Channel 62

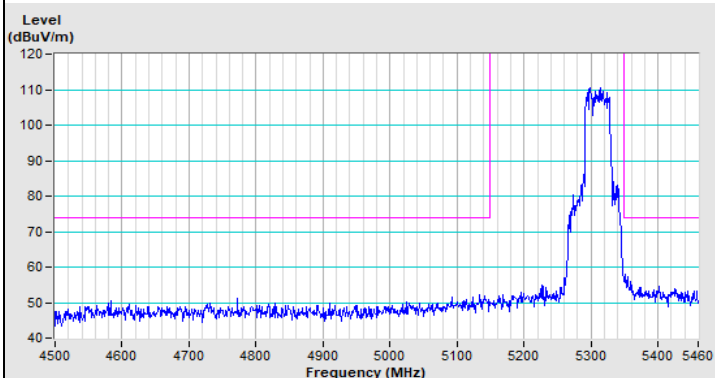

Horizontal (Peak)

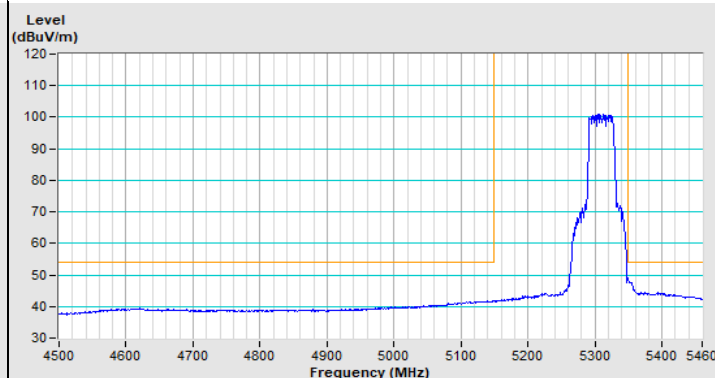

Horizontal (Average)

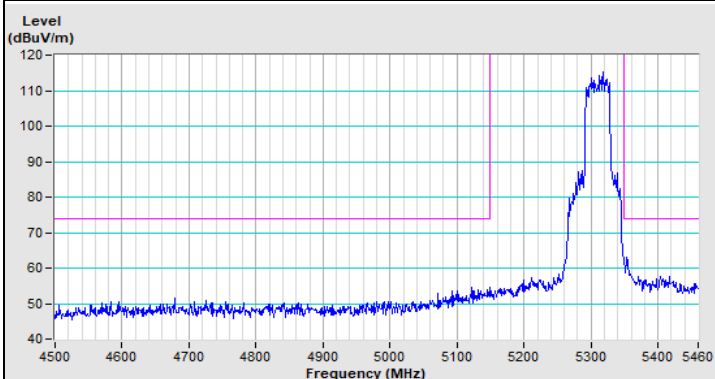

Vertical (Peak)

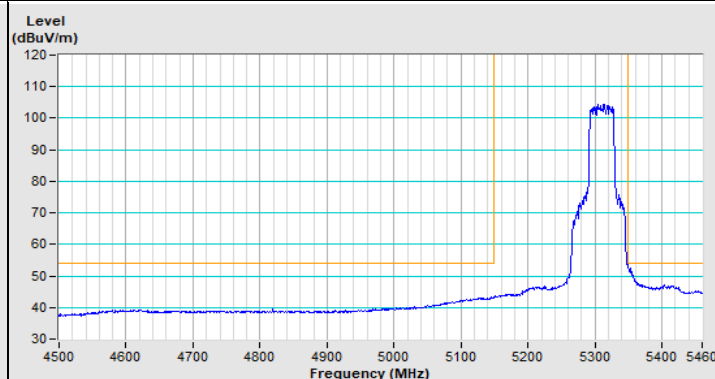

Vertical (Average)

802.11ax (HE40) Channel 102

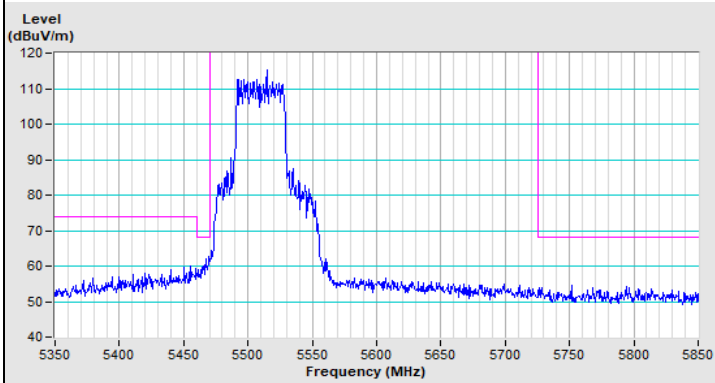

Horizontal (Peak)

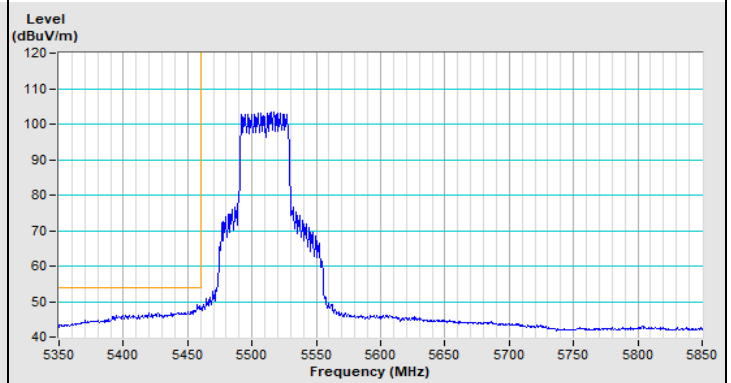

Horizontal (Average)

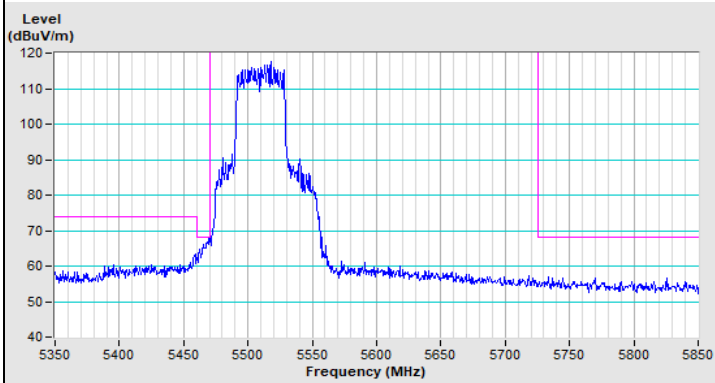

Vertical (Peak)

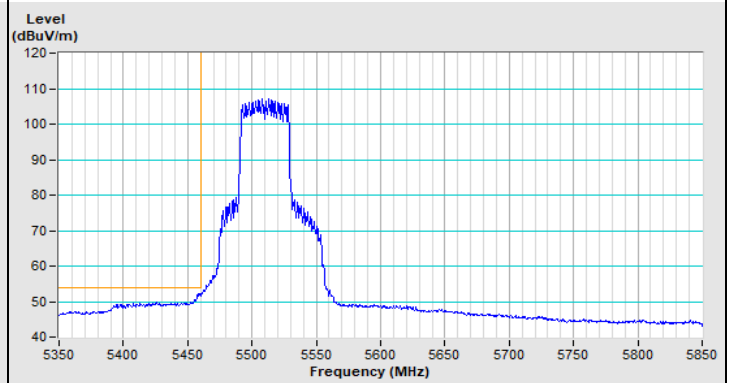

Vertical (Average)

802.11ax (HE40) Channel 151

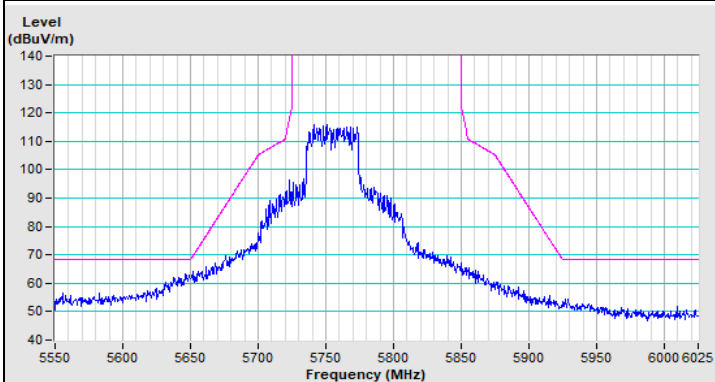

Horizontal (Peak)

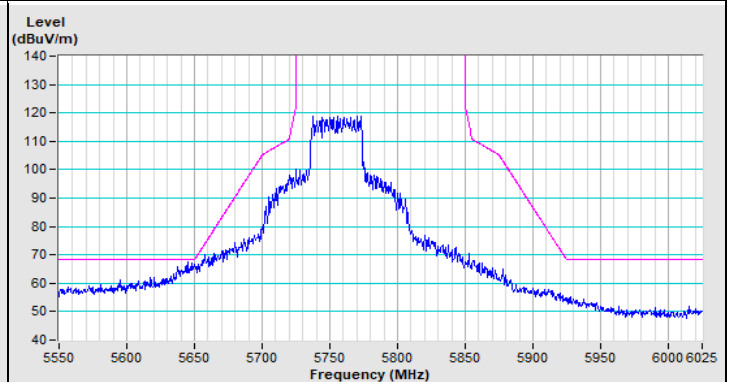

Vertical (Peak)

802.11ax (HE40) Channel 159

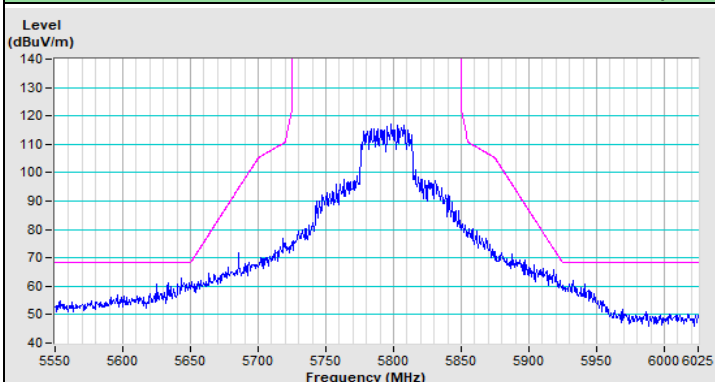

Horizontal (Peak)

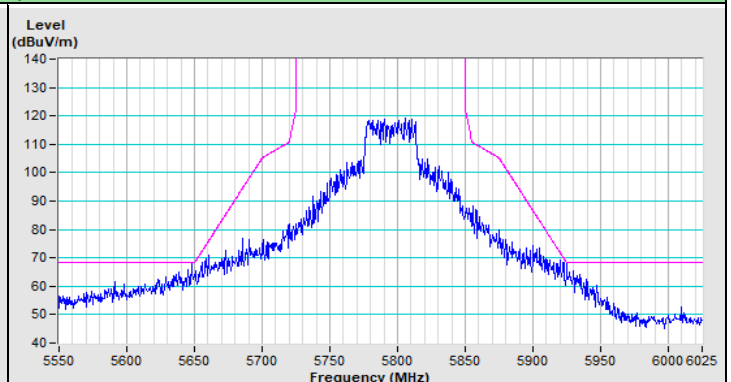

Vertical (Peak)

802.11ax (HE80) Channel 42

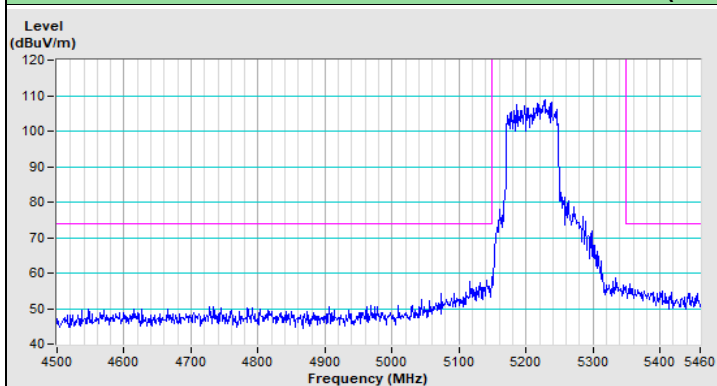

Horizontal (Peak)

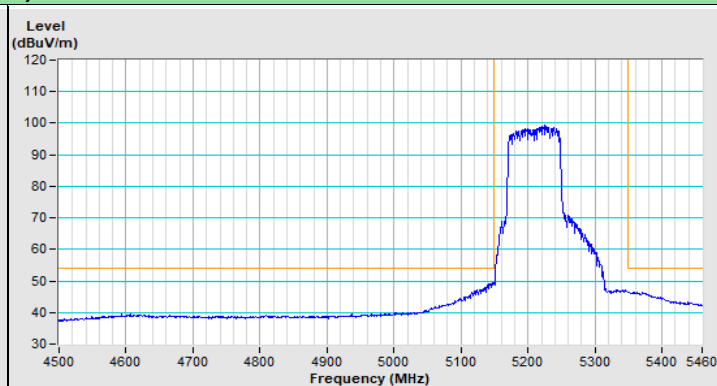

Horizontal (Average)

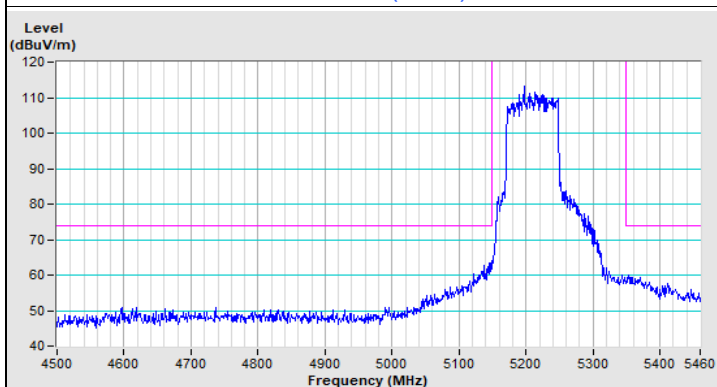

Vertical (Peak)

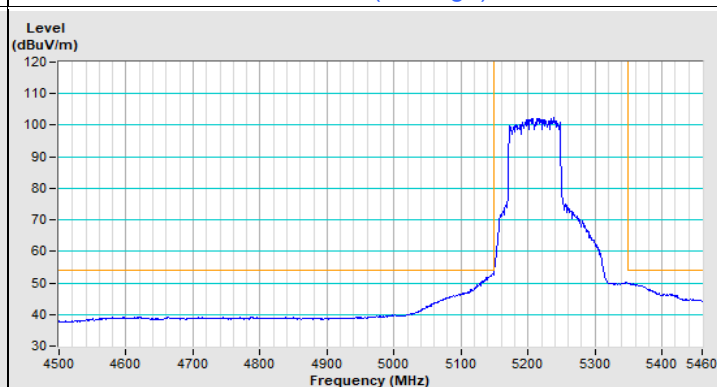

Vertical (Average)

802.11ax (HE80) Channel 58

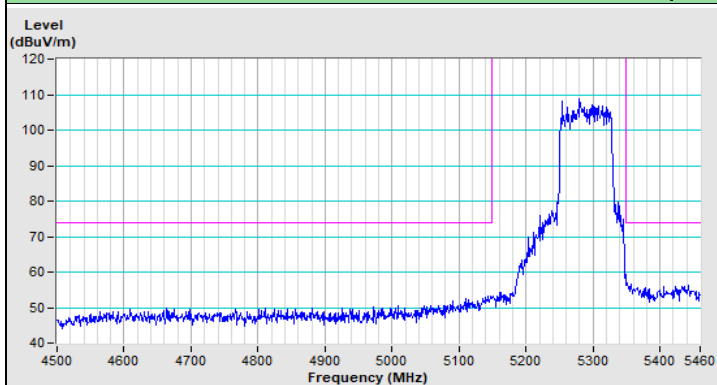

Horizontal (Peak)

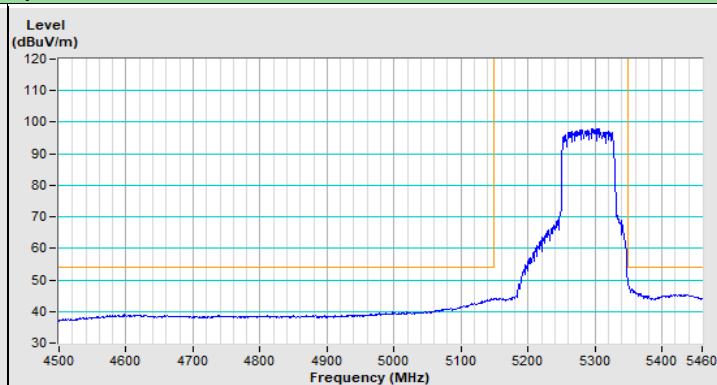

Horizontal (Average)

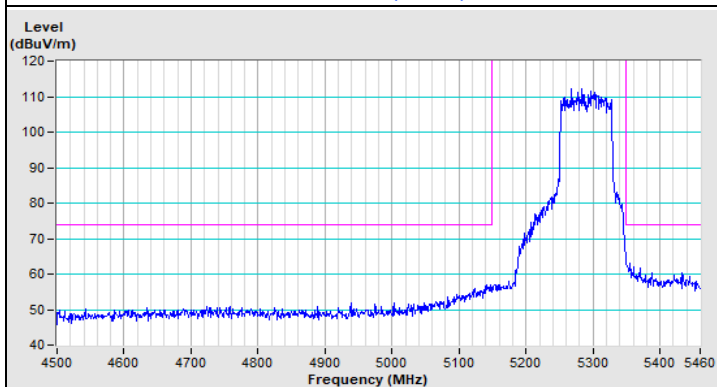

Vertical (Peak)

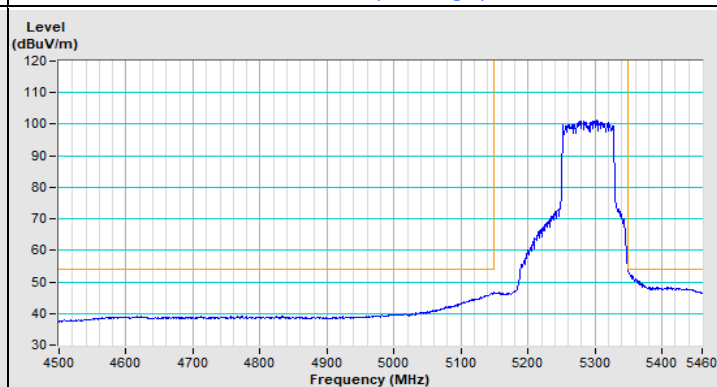

Vertical (Average)

802.11ax (HE80) Channel 106

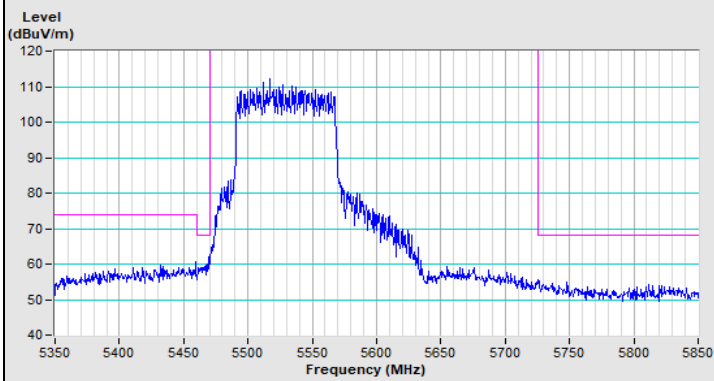

Horizontal (Peak)

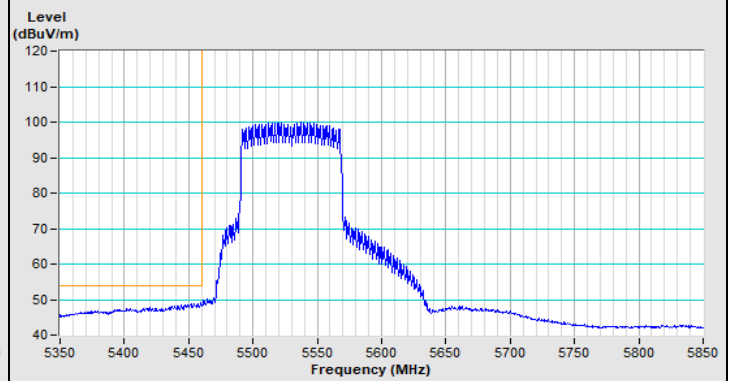

Horizontal (Average)

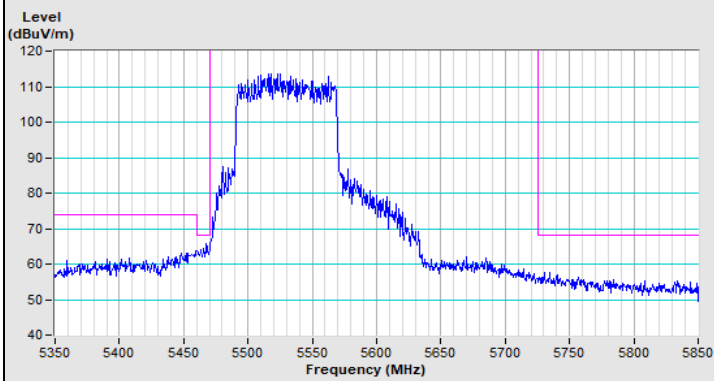

Vertical (Peak)

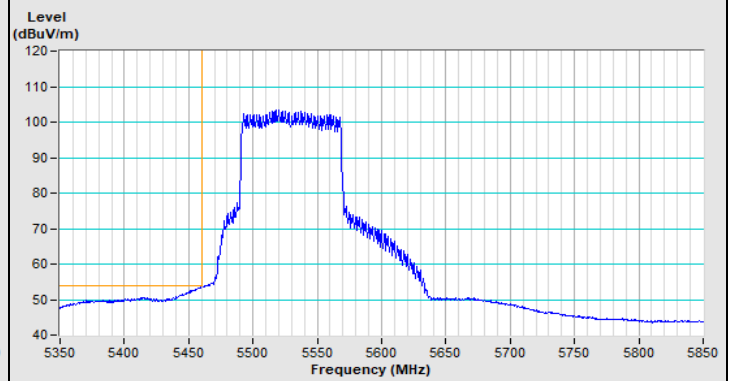

Vertical (Average)

802.11ax (HE80) Channel 155

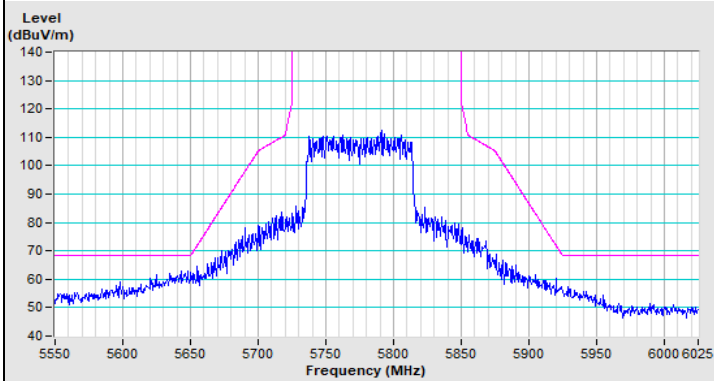

Horizontal (Peak)

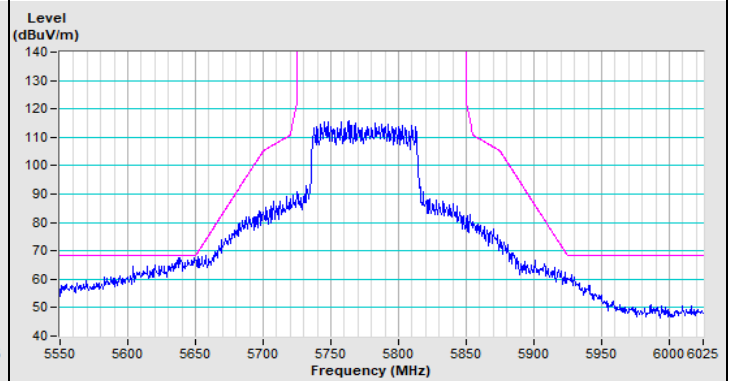

Vertical (Peak)

802.11ax (HE160) Channel 50

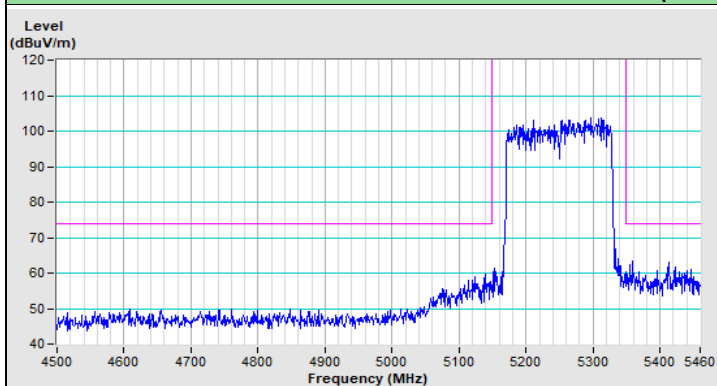

Horizontal (Peak)

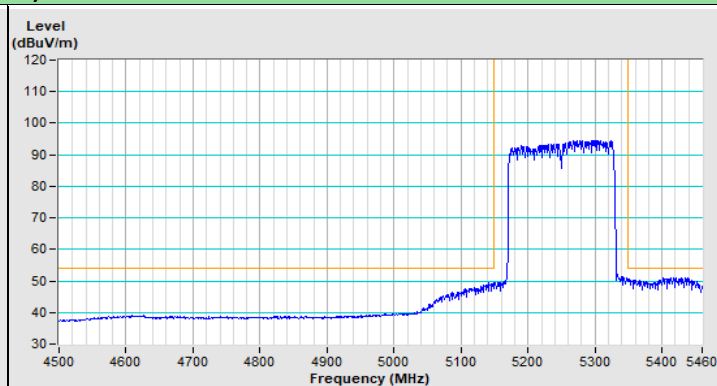

Horizontal (Average)

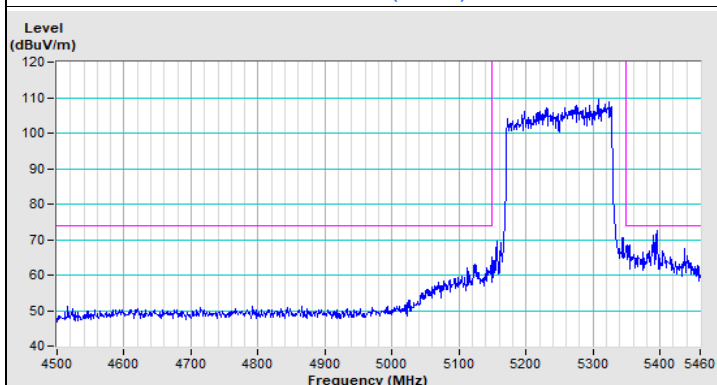

Vertical (Peak)

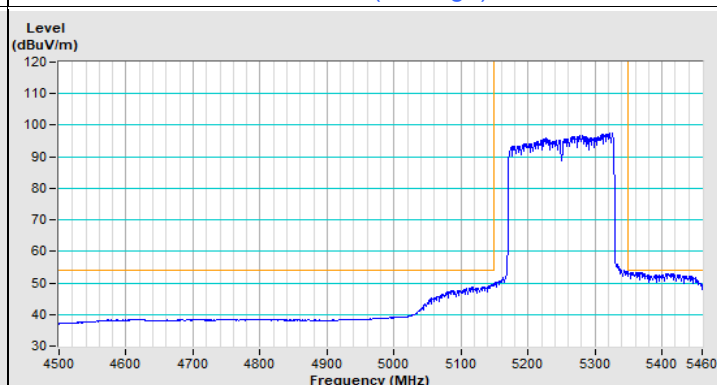

Vertical (Average)

802.11ax (HE160) Channel 114

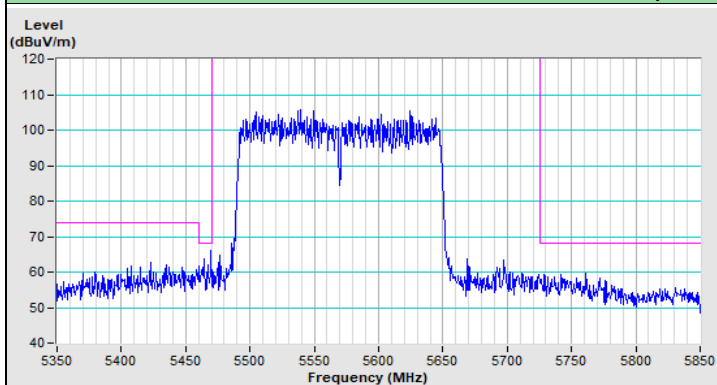

Horizontal (Peak)

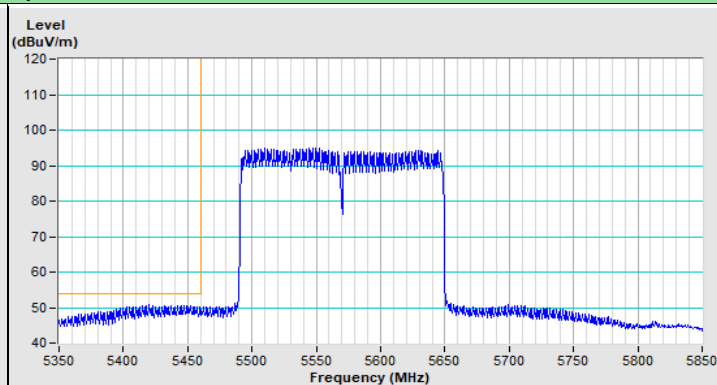

Horizontal (Average)

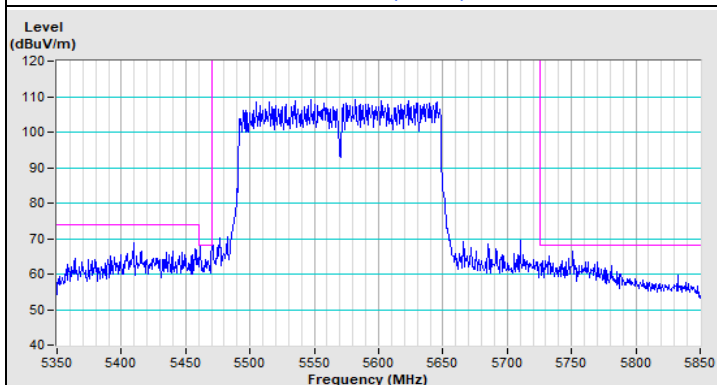

Vertical (Peak)

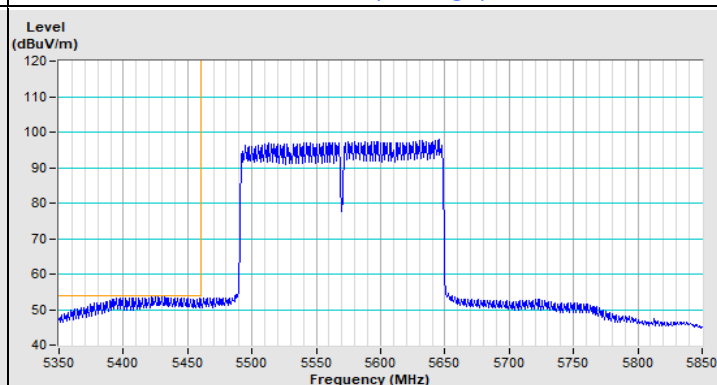

Vertical (Average)

8 Pictures of Test Arrangements

Please refer to the attached file (Test Setup Photo)



9 Information of the Testing Laboratories

We, Bureau Veritas Consumer Products Services (H.K.) Ltd., Taoyuan Branch, were founded in 1988 to provide our best service in EMC, Radio, Telecom and Safety consultation. Our laboratories are FCC recognized accredited test firms and accredited according to ISO/IEC 17025.

If you have any comments, please feel free to contact us at the following:

Lin Kou EMC/RF Lab

Tel: 886-2-26052180

Fax: 886-2-26051924

Hsin Chu EMC/RF/Telecom Lab

Tel: 886-3-6668565

Fax: 886-3-6668323

Hwa Ya EMC/RF/Safety Lab

Tel: 886-3-3183232

Fax: 886-3-3270892

Email: service.adt@bureauveritas.com

Web Site: <http://ee.bureauveritas.com.tw>

The address and road map of all our labs can be found in our web site also.

--- END ---