

FCC Test Report

Report No.: RF181024C03A

FCC ID: PY318400431

Test Model: EX6250

Received Date: Oct. 24, 2018

Test Date: Nov. 07 ~ Dec. 11, 2018

Issued Date: Dec. 28, 2018

Applicant: NETGEAR, INC.

Address: 350 East Plumeria Drive San Jose, CA 95134

Issued By: Bureau Veritas Consumer Products Services (H.K.) Ltd., Taoyuan Branch

Lab Address: No. 47-2, 14th Ling, Chia Pau Vil., Lin Kou Dist., New Taipei City, Taiwan (R.O.C.)

Test Location: No. 19, Hwa Ya 2nd Rd., Wen Hwa Vil., Kwei Shan Dist., Taoyuan City 33383, TAIWAN (R.O.C.)

**FCC Registration /
Designation Number:** 788550 / TW0003



This report is for your exclusive use. Any copying or replication of this report to or for any other person or entity, or use of our name or trademark, is permitted only with our prior written permission. This report sets forth our findings solely with respect to the test samples identified herein. The results set forth in this report are not indicative or representative of the quality or characteristics of the lot from which a test sample was taken or any similar or identical product unless specifically and expressly noted. Our report includes all of the tests requested by you and the results thereof based upon the information that you provided to us. You have 60 days from date of issuance of this report to notify us of any material error or omission caused by our negligence, provided, however, that such notice shall be in writing and shall specifically address the issue you wish to raise. A failure to raise such issue within the prescribed time shall constitute your unqualified acceptance of the completeness of this report, the tests conducted and the correctness of the report contents. Unless specific mention, the uncertainty of measurement has been explicitly taken into account to declare the compliance or non-compliance to the specification. The report must not be used by the client to claim product certification, approval, or endorsement by TAF or any government agencies.

Table of Contents

Release Control Record	4
1 Certificate of Conformity	5
2 Summary of Test Results	6
2.1 Measurement Uncertainty.....	6
2.2 Modification Record.....	6
3 General Information	7
3.1 General Description of EUT.....	7
3.2 Description of Test Modes.....	9
3.2.1 Test Mode Applicability and Tested Channel Detail.....	10
3.3 Duty Cycle of Test Signal.....	12
3.4 Description of Support Units.....	13
3.4.1 Configuration of System under Test.....	13
3.5 General Description of Applied Standards.....	13
4 Test Types and Results	14
4.1 Radiated Emission and Bandedge Measurement.....	14
4.1.1 Limits of Radiated Emission and Bandedge Measurement.....	14
4.1.2 Test Instruments.....	15
4.1.3 Test Procedures.....	16
4.1.4 Deviation from Test Standard.....	16
4.1.5 Test Setup.....	17
4.1.6 EUT Operating Conditions.....	18
4.1.7 Test Results.....	19
4.2 Conducted Emission Measurement.....	45
4.2.1 Limits of Conducted Emission Measurement.....	45
4.2.2 Test Instruments.....	45
4.2.3 Test Procedures.....	46
4.2.4 Deviation from Test Standard.....	46
4.2.5 Test Setup.....	46
4.2.6 EUT Operating Conditions.....	46
4.2.7 Test Results.....	47
4.3 Transmit Power Measurement.....	49
4.3.1 Limits of Transmit Power Measurement.....	49
4.3.2 Test Setup.....	49
4.3.3 Test Instruments.....	49
4.3.4 Test Procedure.....	50
4.3.5 Deviation from Test Standard.....	50
4.3.6 EUT Operating Conditions.....	50
4.3.7 Test Result.....	51
4.4 Occupied Bandwidth Measurement.....	65
4.4.1 Test Setup.....	65
4.4.2 Test Instruments.....	65
4.4.3 Test Procedure.....	65
4.4.4 Test Result.....	66
4.5 Peak Power Spectral Density Measurement.....	68
4.5.1 Limits of Peak Power Spectral Density Measurement.....	68
4.5.2 Test Setup.....	68
4.5.3 Test Instruments.....	68
4.5.4 Test Procedures.....	68
4.5.5 Deviation from Test Standard.....	69
4.5.6 EUT Operating Conditions.....	69
4.5.7 Test Results.....	70
4.6 Frequency Stability.....	75
4.6.1 Limits of Frequency Stability Measurement.....	75

4.6.2	Test Setup.....	75
4.6.3	Test Instruments	75
4.6.4	Test Procedure	75
4.6.5	Deviation from Test Standard	76
4.6.6	EUT Operating Condition	76
4.6.7	Test Results	76
4.7	6dB Bandwidth Measurement.....	77
4.7.1	Limits of 6dB Bandwidth Measurement.....	77
4.7.2	Test Setup.....	77
4.7.3	Test Instruments	77
4.7.4	Test Procedure	77
4.7.5	Deviation from Test Standard	77
4.7.6	EUT Operating Condition	77
4.7.7	Test Results	78
5	Pictures of Test Arrangements.....	80
	Appendix – Information on the Testing Laboratories	81

Release Control Record

Issue No.	Description	Date Issued
RF181024C03A	Original release	Dec. 28, 2018

1 Certificate of Conformity

Product: AC1750 WiFi Mesh Extender

Brand: NETGEAR

Test Model: EX6250

Sample Status: Engineering sample

Applicant: NETGEAR, INC.

Test Date: Nov. 07 ~ Dec. 11, 2018

Standards: 47 CFR FCC Part 15, Subpart E (Section 15.407)
ANSI C63.10:2013

The above equipment has been tested by **Bureau Veritas Consumer Products Services (H.K.) Ltd., Taoyuan Branch**, and found compliance with the requirement of the above standards. The test record, data evaluation & Equipment Under Test (EUT) configurations represented herein are true and accurate accounts of the measurements of the sample's RF characteristics under the conditions specified in this report.

Prepared by : Celine Chou , **Date:** Dec. 28, 2018
Celine Chou / Senior Specialist

Approved by : Bruce Chen , **Date:** Dec. 28, 2018
Bruce Chen / Project Engineer

2 Summary of Test Results

47 CFR FCC Part 15, Subpart E (Section 15.407)			
FCC Clause	Test Item	Result	Remarks
15.407(b)(6)	AC Power Conducted Emissions	Pass	Meet the requirement of limit. Minimum passing margin is -12.57dB at 0.56121MHz.
15.407(b)(1/2/3/4(i/ii)/6)	Radiated Emissions & Band Edge Measurement	Pass	Meet the requirement of limit. Minimum passing margin is -0.1dB at 5350.00MHz.
15.407(a)(1/2/3)	Max Average Transmit Power	Pass	Meet the requirement of limit.
---	Occupied Bandwidth Measurement	-	Reference only.
15.407(a)(1/2/3)	Peak Power Spectral Density	Pass	Meet the requirement of limit.
15.407(e)	6dB bandwidth	Pass	Meet the requirement of limit. (U-NII-3 Band only)
15.407(g)	Frequency Stability	Pass	Meet the requirement of limit.
15.203	Antenna Requirement	Pass	No antenna connector is used.

2.1 Measurement Uncertainty

Where relevant, the following measurement uncertainty levels have been estimated for tests performed on the EUT as specified in CISPR 16-4-2:

Measurement	Frequency	Expanded Uncertainty (k=2) (\pm)
Conducted Emissions at mains ports	150kHz ~ 30MHz	2.94 dB
Radiated Emissions up to 1 GHz	30MHz ~ 200MHz	3.63 dB
	200MHz ~ 1000MHz	3.64 dB
Radiated Emissions above 1 GHz	1GHz ~ 18GHz	2.29 dB
	18GHz ~ 40GHz	2.29 dB

2.2 Modification Record

There were no modifications required for compliance.

3 General Information

3.1 General Description of EUT

Product	AC1750 WiFi Mesh Extender
Brand	NETGEAR
Test Model	EX6250
Sample Status	Engineering sample
Power Supply Rating	100-240Vac
Modulation Type	256QAM, 64QAM, 16QAM, QPSK, BPSK
Modulation Technology	OFDM
Transfer Rate	802.11a: 54/48/36/24/18/12/9/6Mbps 802.11n: up to 450.0Mbps 802.11ac: 1300.0Mbps
Operating Frequency	5260 ~ 5320MHz, 5500 ~ 5720MHz
Number of Channel	5260 ~ 5320MHz: 802.11a, 802.11n (HT20), 802.11ac (VHT20): 4 802.11n (HT40), 802.11ac (VHT40): 2 802.11ac (VHT80): 1 5500 ~ 5720MHz: 802.11a, 802.11n (HT20), 802.11ac (VHT20): 12 802.11n (HT40), 802.11ac (VHT40): 6 802.11ac (VHT80): 3
Conducted Output Power	CDD Mode: 5260 ~ 5320MHz: 223.784mW 5500 ~ 5720MHz: 218.011mW Beamforming Mode: 5260 ~ 5320MHz: 223.782mW 5500 ~ 5720MHz: 218.011mW
Antenna Type	Refer to note
Antenna Connector	Refer to note
Accessory Device	NA
Cable Supplied	NA

Note:

1. This report is prepared for FCC class II permissive change. The differences compared with the original report (BV CPS report no.: RF181024C03-1) are adding 5.26GHz to 5.32GHz and 5.50GHz to 5.72GHz by software.

2. The EUT incorporates a MIMO function. Physically, the EUT provides 3 completed transmitters and 3 receivers.

Modulation Mode	TX Function	Beamforming
802.11a	3TX	Not Support
802.11n (HT20)	3TX	Support
802.11n (HT40)	3TX	Support
802.11ac (VHT20)	3TX	Support
802.11ac (VHT40)	3TX	Support
802.11ac (VHT80)	3TX	Support

* The modulation and bandwidth are similar for 802.11n mode for HT20/HT40 and 802.11ac mode for VHT20/VHT40, therefore investigated worst case to representative mode in test report. (Final test mode refer section 3.2.1)

* CDD mode is the worst case for final tests except output power test after pretesting CDD mode and beamforming mode.

3. The EUT uses following antennas.

Ant. Type	PIFA		
Connector Type	NA		
Directional Antenna Gain (dBi)			
5G Band 1	5G Band 2	5G Band 3	5G Band 4
4.34	4.15	4.17	4.80

3.2 Description of Test Modes

For 5260 ~ 5320MHz:

4 channels are provided for 802.11a, 802.11n (HT20):

Channel	Frequency	Channel	Frequency
52	5260 MHz	60	5300 MHz
56	5280 MHz	64	5320 MHz

2 channels are provided for 802.11n (HT40):

Channel	Frequency	Channel	Frequency
54	5270 MHz	62	5310 MHz

1 channel is provided for 802.11ac (VHT80):

Channel	Frequency
58	5290MHz

For 5500 ~ 5720MHz:

12 channels are provided for 802.11a, 802.11n (HT20), 802.11ac (VHT20):

Channel	Frequency	Channel	Frequency
100	5500 MHz	124	5620 MHz
104	5520 MHz	128	5640 MHz
108	5540 MHz	132	5660 MHz
112	5560 MHz	136	5680 MHz
116	5580 MHz	140	5700 MHz
120	5600 MHz	144	5720 MHz

6 channels are provided for 802.11n (HT40), 802.11ac (VHT40):

Channel	Frequency	Channel	Frequency
102	5510 MHz	126	5630 MHz
110	5550 MHz	134	5670 MHz
118	5590 MHz	142	5710 MHz

3 channels are provided for 802.11ac (VHT80):

Channel	Frequency	Channel	Frequency
106	5530 MHz	122	5610 MHz
138	5690 MHz		

3.2.1 Test Mode Applicability and Tested Channel Detail

EUT Configure Mode	Applicable to				Description
	RE \geq 1G	RE<1G	PLC	APCM	
-	√	√	√	√	-

Where RE \geq 1G: Radiated Emission above 1GHz & Bandedge Measurement
 RE<1G: Radiated Emission below 1GHz
 PLC: Power Line Conducted Emission
 APCM: Antenna Port Conducted Measurement

Note: The EUT had been pre-tested on the positioned of each 3 axis. The worst case was found when positioned on **Z-plane**.

Radiated Emission Test (Above 1GHz):

- Pre-Scan has been conducted to determine the worst-case mode from all possible combinations between available modulations, data rates and antenna ports (if EUT with antenna diversity architecture).
- Following channel(s) was (were) selected for the final test as listed below.

EUT Configure Mode	Mode	Frequency Band (MHz)	Available Channel	Tested Channel	Modulation Technology	Data Rate (Mbps)
-	802.11a	5260-5320	52 to 64	52, 60, 64	OFDM	6.0
	802.11n (HT20)		52 to 64	52, 60, 64	OFDM	6.5
	802.11n (HT40)		54 to 62	54, 62	OFDM	13.5
	802.11ac (VHT80)		58	58	OFDM	29.3
-	802.11a	5500-5720	100 to 144	100, 116, 140, 144	OFDM	6.0
	802.11n (HT20)		100 to 144	100, 116, 140, 144	OFDM	6.5
	802.11n (HT40)		102 to 142	102, 110, 134, 142	OFDM	13.5
	802.11ac (VHT80)		106 to 138	106, 122, 138	OFDM	29.3

Radiated Emission Test (Below 1GHz):

- Pre-Scan has been conducted to determine the worst-case mode from all possible combinations between available modulations, data rates and antenna ports (if EUT with antenna diversity architecture).
- Following channel(s) was (were) selected for the final test as listed below.

EUT Configure Mode	Mode	Frequency Band (MHz)	Available Channel	Tested Channel	Modulation Technology	Data Rate (Mbps)
-	802.11a	5260-5320	52 to 64	52	OFDM	6.0
	802.11a	5500-5720	100 to 144		OFDM	6.0

Power Line Conducted Emission Test:

- Pre-Scan has been conducted to determine the worst-case mode from all possible combinations between available modulations, data rates and antenna ports (if EUT with antenna diversity architecture).
- Following channel(s) was (were) selected for the final test as listed below.

EUT Configure Mode	Mode	Frequency Band (MHz)	Available Channel	Tested Channel	Modulation Technology	Data Rate (Mbps)
-	802.11a	5260-5320	52 to 64	52	OFDM	6.0
	802.11a	5500-5720	100 to 144		OFDM	6.0

Antenna Port Conducted Measurement:

- This item includes all test value of each mode, but only includes spectrum plot of worst value of each mode.
- Pre-Scan has been conducted to determine the worst-case mode from all possible combinations between available modulations, data rates and antenna ports (if EUT with antenna diversity architecture).
- Following channel(s) was (were) selected for the final test as listed below.

EUT Configure Mode	Mode	Frequency Band (MHz)	Available Channel	Tested Channel	Modulation Technology	Data Rate (Mbps)
-	802.11a	5260-5320	52 to 64	52, 60, 64	OFDM	6.0
	802.11n (HT20)		52 to 64	52, 60, 64	OFDM	6.5
	802.11n (HT40)		54 to 62	54, 62	OFDM	13.5
	802.11ac (VHT80)		58	58	OFDM	29.3
-	802.11a	5500-5720	100 to 144	100, 116, 140, 144	OFDM	6.0
	802.11n (HT20)		100 to 144	100, 116, 140, 144	OFDM	6.5
	802.11n (HT40)		102 to 142	102, 110, 134, 142	OFDM	13.5
	802.11ac (VHT80)		106 to 138	106, 122, 138	OFDM	29.3

Test Condition:

Applicable to	Environmental Conditions	Input Power	Tested by
RE \geq 1G	25 deg. C, 70% RH	120Vac, 60Hz	Luis Lee
RE $<$ 1G	25 deg. C, 71% RH	120Vac, 60Hz	Noah Chang
PLC	25 deg. C, 75% RH	120Vac, 60Hz	Noah Chang
APCM	25 deg. C, 70% RH	120Vac, 60Hz	Alan Wu

3.3 Duty Cycle of Test Signal

Duty cycle of test signal is < 98%, duty factor is required.

802.11a: Duty cycle = 2.055/2.133 = 0.963, Duty factor = $10 \cdot \log(1/0.963) = 0.16$

802.11n (HT20): Duty cycle = 2.060/2.132 = 0.966, Duty factor = $10 \cdot \log(1/0.966) = 0.15$

802.11n (HT40): Duty cycle = 2.427/2.505 = 0.969, Duty factor = $10 \cdot \log(1/0.969) = 0.14$

802.11ac (VHT80): Duty cycle = 1.137/1.210 = 0.940, Duty factor = $10 \cdot \log(1/0.940) = 0.27$



3.4 Description of Support Units

The EUT has been tested as an independent unit together with other necessary accessories or support units. The following support units or accessories were used to form a representative test configuration during the tests.

ID	Product	Brand	Model No.	Serial No.	FCC ID	Remarks
A.	Notebook	ASUS	P2420L	FCNXCXV16385351D	FCC DoC Approved	-

Note:

1. All power cords of the above support units are non-shielded (1.8m).
2. Item A acted as a communication partner to transfer data.

ID	Descriptions	Qty.	Length (m)	Shielding (Yes/No)	Cores (Qty.)	Remarks
1.	RJ45, Cat5e cable	1	10	N	0	-

3.4.1 Configuration of System under Test

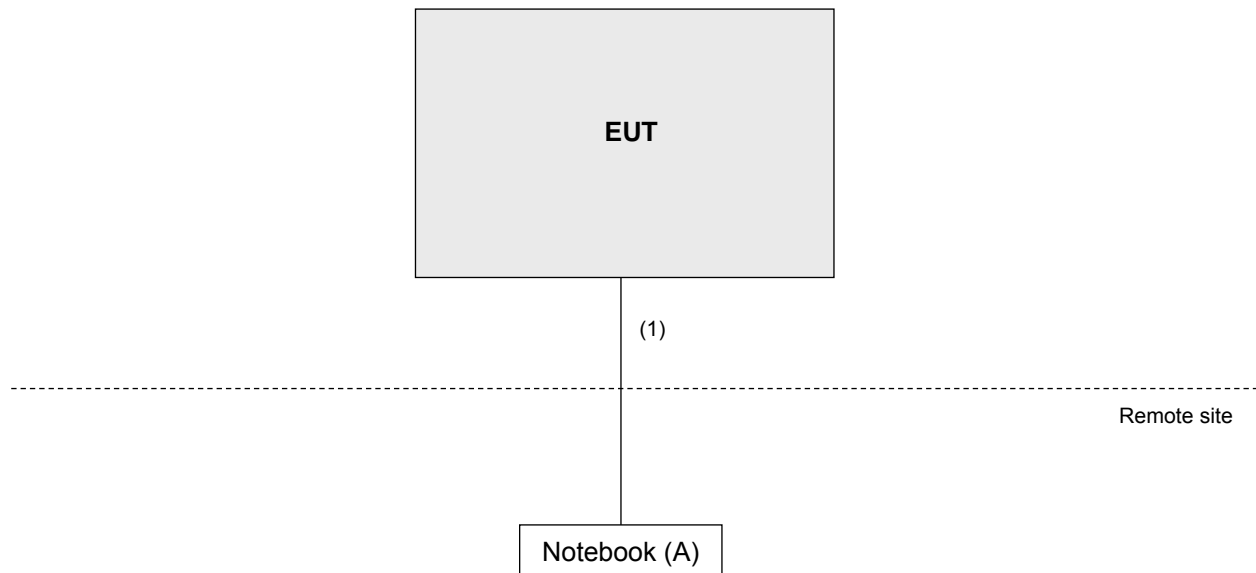

3.5 General Description of Applied Standards

The EUT is a RF Product. According to the specifications of the manufacturer, it must comply with the requirements of the following standards:

FCC Part 15, Subpart E (15.407)

KDB 789033 D02 General UNII Test Procedure New Rules v02r01

KDB 662911 D01 Multiple Transmitter Output v02r01

ANSI C63.10:2013

All test items have been performed and recorded as per the above standards.

4 Test Types and Results

4.1 Radiated Emission and Bandedge Measurement

4.1.1 Limits of Radiated Emission and Bandedge Measurement

Radiated emissions which fall in the restricted bands must comply with the radiated emission limits specified as below table.

Frequencies (MHz)	Field Strength (microvolts/meter)	Measurement Distance (meters)
0.009 ~ 0.490	2400/F(kHz)	300
0.490 ~ 1.705	24000/F(kHz)	30
1.705 ~ 30.0	30	30
30 ~ 88	100	3
88 ~ 216	150	3
216 ~ 960	200	3
Above 960	500	3

Note:

1. The lower limit shall apply at the transition frequencies.
2. Emission level (dBuV/m) = 20 log Emission level (uV/m).
3. For frequencies above 1000MHz, the field strength limits are based on average detector, however, the peak field strength of any emission shall not exceed the maximum permitted average limits, specified above by more than 20dB under any condition of modulation.

Limits of unwanted emission out of the restricted bands

Applicable To		Limit	
789033 D02 General UNII Test Procedure New Rules v02r01		Field Strength at 3m	
		PK: 74 (dBuV/m)	AV: 54 (dBuV/m)
Frequency Band	Applicable To	EIRP Limit	Equivalent Field Strength at 3m
5150~5250 MHz	15.407(b)(1)	PK: -27 (dBm/MHz)	PK: 68.2(dBuV/m)
5250~5350 MHz	15.407(b)(2)		
5470~5725 MHz	15.407(b)(3)		
5725~5850 MHz	<input checked="" type="checkbox"/> 15.407(b)(4)(i)	PK: -27 (dBm/MHz) ^{*1} PK: 10 (dBm/MHz) ^{*2} PK: 15.6 (dBm/MHz) ^{*3} PK: 27 (dBm/MHz) ^{*4}	PK: 68.2(dBuV/m) ^{*1} PK: 105.2 (dBuV/m) ^{*2} PK: 110.8(dBuV/m) ^{*3} PK: 122.2 (dBuV/m) ^{*4}
	<input type="checkbox"/> 15.407(b)(4)(ii)	Emission limits in section 15.247(d)	
^{*1} beyond 75 MHz or more above of the band edge.		^{*2} below the band edge increasing linearly to 10 dBm/MHz at 25 MHz above.	
^{*3} below the band edge increasing linearly to a level of 15.6 dBm/MHz at 5 MHz above.		^{*4} from 5 MHz above or below the band edge increasing linearly to a level of 27 dBm/MHz at the band edge.	

Note: The following formula is used to convert the equipment isotropic radiated power (eirp) to field strength:

$$E = \frac{1000000\sqrt{30P}}{3} \mu\text{V/m, where P is the eirp (Watts).}$$

4.1.2 Test Instruments

Description & Manufacturer	Model No.	Serial No.	Cal. Date	Cal. Due
Test Receiver ROHDE & SCHWARZ	ESIB7	100187	May 29, 2018	May 28, 2019
Spectrum Analyzer ROHDE & SCHWARZ	FSP40	100040	Sep. 25, 2018	Sep. 24, 2019
BILOG Antenna SCHWARZBECK	VULB9168	9168-155	Dec. 11, 2017	Dec. 10, 2018
			Nov. 21, 2018	Nov. 20, 2019
HORN Antenna SCHWARZBECK	BBHA 9120D	9120D-1170	Mar. 25, 2018	Mar. 24, 2019
HORN Antenna SCHWARZBECK	BBHA 9170	BBHA9170241	Dec. 01, 2017	Nov. 30, 2018
			Nov. 25, 2018	Nov. 24, 2019
Loop Antenna TESEQ	HLA 6121	45745	Jun. 14, 2018	Jun. 13, 2019
Preamplifier Agilent (Below 1GHz)	8447D	2944A10631	Aug. 08, 2018	Aug. 07, 2019
Preamplifier KEYSIGHT (Above 1GHz)	83017A	MY53270295	Jul. 02, 2018	Jul. 01, 2019
RF signal cable HUBER+SUHNER	SUCOFLEX 104	MY 13380+295012/04	Aug. 08, 2018	Aug. 07, 2019
RF signal cable HUBER+SUHNER	SUCOFLEX 104	Cable-CH4-03 (250724)	Aug. 08, 2018	Aug. 07, 2019
Software BV ADT	ADT_Radiated_ V7.6.15.9.5	NA	NA	NA
Antenna Tower inn-co GmbH	MA 4000	010303	NA	NA
Antenna Tower Controller BV ADT	AT100	AT93021703	NA	NA
Turn Table BV ADT	TT100	TT93021703	NA	NA
Turn Table Controller BV ADT	SC100	SC93021703	NA	NA
Boresight Antenna Fixture	FBA-01	FBA-SIP01	NA	NA
Pre-amplifier (18GHz-40GHz) EMC	EMC184045B	980175	Nov. 14, 2017	Nov. 13, 2018
			Nov. 14, 2018	Nov. 13, 2019
USB Wideband Power Sensor KEYSIGHT	U2021XA	MY55050005/MY5519000 4/MY55190007/MY55210 005	Jul. 17, 2018	Jul. 16, 2019

- Note: 1. The calibration interval of the above test instruments is 12 months and the calibrations are traceable to NML/ROC and NIST/USA.
2. The test was performed in HwaYa Chamber 4.
3. The FCC Designation Number is TW0003. The number will be varied with the Lab location and scope as attached.
4. The IC Site Registration No. is 7450F-4.

4.1.3 Test Procedures

For Radiated emission below 30MHz

- a. The EUT was placed on the top of a rotating table 0.8 meters above the ground at a 3 meter chamber room. The table was rotated 360 degrees to determine the position of the highest radiation.
- b. The EUT was set 3 meters away from the interference-receiving antenna, which was mounted on the top of a variable-height antenna tower.
- c. Parallel, perpendicular, and ground-parallel orientations of the antenna are set to make the measurement.
- d. For each suspected emission, the EUT was arranged to its worst case and the rotatable table was turned from 0 degrees to 360 degrees to find the maximum reading.
- e. The test-receiver system was set to Quasi-Peak Detect Function and Specified Bandwidth with Maximum Hold Mode.

Note:

1. The resolution bandwidth and video bandwidth of test receiver/spectrum analyzer is 9kHz at frequency below 30MHz.

For Radiated emission above 30MHz

- a. The EUT was placed on the top of a rotating table 0.8 meters (for 30MHz ~ 1GHz) / 1.5 meters (for above 1GHz) above the ground at 3 meter chamber room for test. The table was rotated 360 degrees to determine the position of the highest radiation.
- b. The EUT was set 3 meters away from the interference-receiving antenna, which was mounted on the top of a variable-height antenna tower.
- c. The height of antenna is varied from one meter to four meters above the ground to determine the maximum value of the field strength. Both horizontal and vertical polarizations of the antenna are set to make the measurement.
- d. For each suspected emission, the EUT was arranged to its worst case and then the antenna was tuned to heights from 1 meter to 4 meters and the rotatable table was turned from 0 degrees to 360 degrees to find the maximum reading.
- e. The test-receiver system was set to quasi-peak detect function and specified bandwidth with maximum hold mode when the test frequency is below 1 GHz.
- f. The test-receiver system was set to peak and average detect function and specified bandwidth with maximum hold mode when the test frequency is above 1 GHz. If the peak reading value also meets average limit, measurement with the average detector is unnecessary.

Note:

1. The resolution bandwidth and video bandwidth of test receiver/spectrum analyzer is 120kHz for Quasi-peak detection (QP) at frequency below 1GHz.
2. The resolution bandwidth of test receiver/spectrum analyzer is 1 MHz and the video bandwidth is 3 MHz for Peak detection (PK) at frequency above 1GHz.
3. The resolution bandwidth of test receiver/spectrum analyzer is 1MHz and the video bandwidth is $\geq 1/T$ (Duty cycle < 98%) or 10Hz (Duty cycle $\geq 98\%$) for Average detection (AV) at frequency above 1GHz.
4. All modes of operation were investigated and the worst-case emissions are reported.

4.1.4 Deviation from Test Standard

No deviation.

4.1.5 Test Setup

For Radiated emission below 30MHz

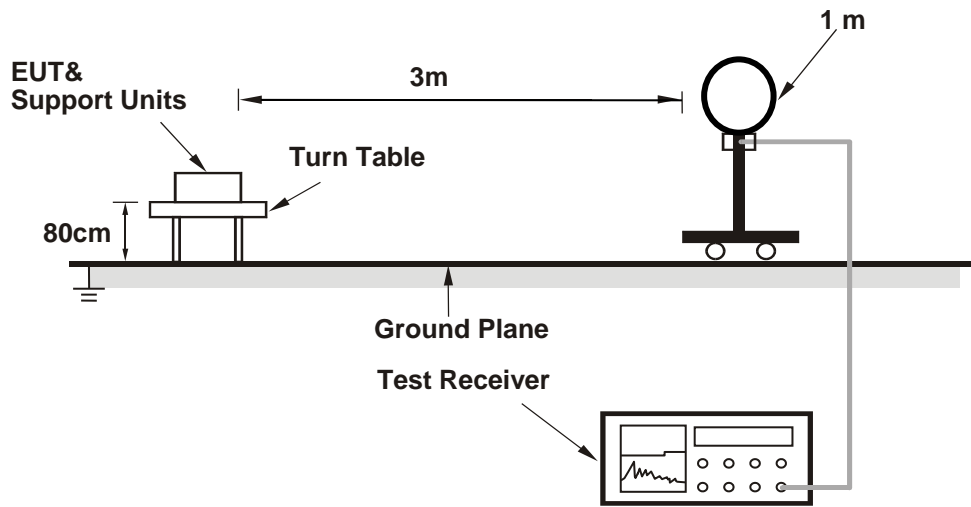

For Radiated emission 30MHz to 1GHz

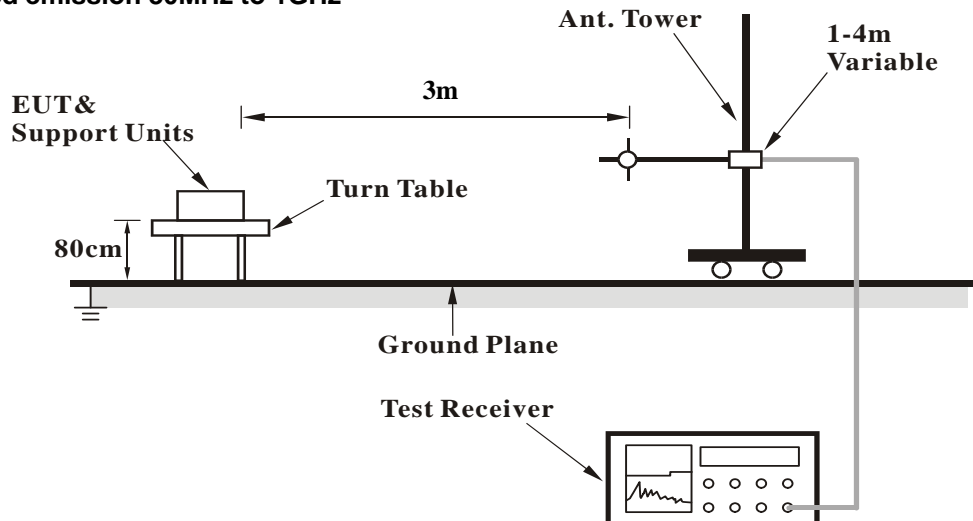

For Radiated emission above 1GHz

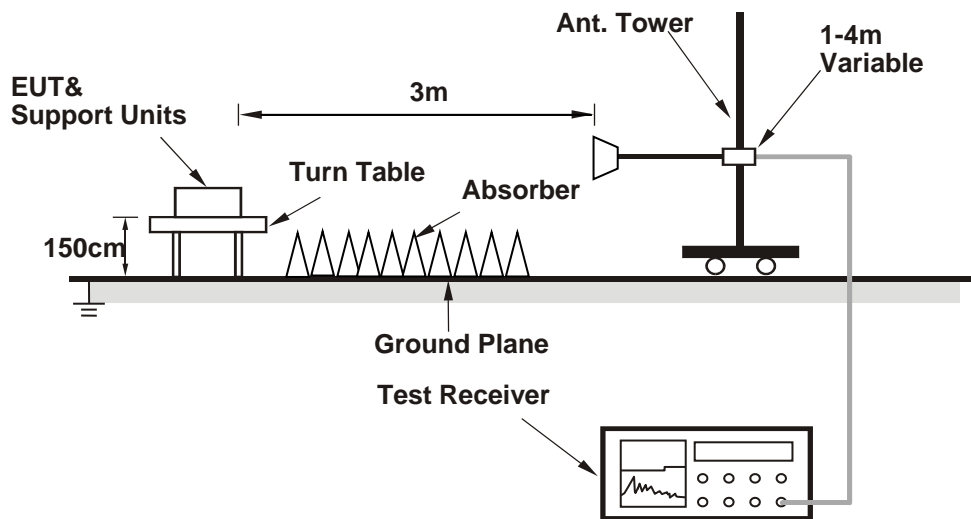

For the actual test configuration, please refer to the attached file (Test Setup Photo).

4.1.6 EUT Operating Conditions

- a. Placed the EUT on the testing table.
- b. Prepared a notebook to act as a communication partner and placed it outside of testing area.
- c. The communication partner connected with EUT via a RJ45 cable and ran a test program (provided by manufacturer) to enable EUT under transmission condition continuously at specific channel frequency.
- d. The communication partner sent data to EUT by command "PING".

4.1.7 Test Results

Above 1GHz data:

802.11a

CHANNEL	TX Channel 52	DETECTOR FUNCTION	Peak (PK)
FREQUENCY RANGE	1GHz ~ 40GHz		Average (AV)

ANTENNA POLARITY & TEST DISTANCE: HORIZONTAL AT 3 M								
NO.	FREQ. (MHz)	EMISSION LEVEL (dBuV/m)	LIMIT (dBuV/m)	MARGIN (dB)	ANTENNA HEIGHT (m)	TABLE ANGLE (Degree)	RAW VALUE (dBuV)	CORRECTION FACTOR (dB/m)
1	5150.00	59.5 PK	74.0	-14.5	1.01 H	239	47.7	11.8
2	5150.00	46.6 AV	54.0	-7.4	1.01 H	239	34.8	11.8
3	*5260.00	112.8 PK			1.01 H	239	72.3	40.5
4	*5260.00	102.3 AV			1.01 H	239	61.8	40.5
5	#10520.00	61.2 PK	68.2	-7.0	2.63 H	152	38.9	22.3

ANTENNA POLARITY & TEST DISTANCE: VERTICAL AT 3 M								
NO.	FREQ. (MHz)	EMISSION LEVEL (dBuV/m)	LIMIT (dBuV/m)	MARGIN (dB)	ANTENNA HEIGHT (m)	TABLE ANGLE (Degree)	RAW VALUE (dBuV)	CORRECTION FACTOR (dB/m)
1	5150.00	59.9 PK	74.0	-14.1	1.23 V	227	48.1	11.8
2	5150.00	46.6 AV	54.0	-7.4	1.23 V	227	34.8	11.8
3	*5260.00	115.5 PK			1.23 V	227	75.0	40.5
4	*5260.00	105.6 AV			1.23 V	227	65.1	40.5
5	#10520.00	61.5 PK	68.2	-6.7	1.83 V	190	39.2	22.3

Remarks:

1. Emission Level(dBuV/m) = Raw Value(dBuV) + Correction Factor(dB/m)
2. Correction Factor(dB/m) = Antenna Factor(dB/m) + Cable Factor(dB) – Pre-Amplifier Factor(dB)
3. The other emission levels were very low against the limit
4. Margin value = Emission Level – Limit value
5. " * ": Fundamental frequency
6. " # ": The radiated frequency is out of the restricted band

CHANNEL	TX Channel 60	DETECTOR FUNCTION	Peak (PK)
FREQUENCY RANGE	1GHz ~ 40GHz		Average (AV)

ANTENNA POLARITY & TEST DISTANCE: HORIZONTAL AT 3 M

NO.	FREQ. (MHz)	EMISSION LEVEL (dBuV/m)	LIMIT (dBuV/m)	MARGIN (dB)	ANTENNA HEIGHT (m)	TABLE ANGLE (Degree)	RAW VALUE (dBuV)	CORRECTION FACTOR (dB/m)
1	*5300.00	112.4 PK			1.03 H	251	72.0	40.4
2	*5300.00	101.9 AV			1.03 H	251	61.5	40.4
3	10600.00	61.5 PK	74.0	-12.5	1.98 H	145	39.2	22.3
4	10600.00	48.7 AV	54.0	-5.3	1.98 H	145	26.4	22.3

ANTENNA POLARITY & TEST DISTANCE: VERTICAL AT 3 M

NO.	FREQ. (MHz)	EMISSION LEVEL (dBuV/m)	LIMIT (dBuV/m)	MARGIN (dB)	ANTENNA HEIGHT (m)	TABLE ANGLE (Degree)	RAW VALUE (dBuV)	CORRECTION FACTOR (dB/m)
1	*5300.00	115.6 PK			1.26 V	210	75.2	40.4
2	*5300.00	105.2 AV			1.26 V	210	64.8	40.4
3	10600.00	62.1 PK	74.0	-11.9	1.48 V	265	39.8	22.3
4	10600.00	49.0 AV	54.0	-5.0	1.48 V	265	26.7	22.3

Remarks:

1. Emission Level(dBuV/m) = Raw Value(dBuV) + Correction Factor(dB/m)
2. Correction Factor(dB/m) = Antenna Factor(dB/m) + Cable Factor(dB) – Pre-Amplifier Factor(dB)
3. The other emission levels were very low against the limit
4. Margin value = Emission Level – Limit value
5. " * ": Fundamental frequency
6. " # ": The radiated frequency is out of the restricted band

CHANNEL	TX Channel 64	DETECTOR FUNCTION	Peak (PK)
FREQUENCY RANGE	1GHz ~ 40GHz		Average (AV)

ANTENNA POLARITY & TEST DISTANCE: HORIZONTAL AT 3 M

NO.	FREQ. (MHz)	EMISSION LEVEL (dBuV/m)	LIMIT (dBuV/m)	MARGIN (dB)	ANTENNA HEIGHT (m)	TABLE ANGLE (Degree)	RAW VALUE (dBuV)	CORRECTION FACTOR (dB/m)
1	*5320.00	110.7 PK			1.21 H	236	70.1	40.6
2	*5320.00	99.6 AV			1.21 H	236	59.0	40.6
3	5350.00	63.0 PK	74.0	-11.0	1.21 H	236	51.1	11.9
4	5350.00	50.8 AV	54.0	-3.2	1.21 H	236	38.9	11.9
5	10640.00	61.5 PK	74.0	-12.5	1.73 H	216	39.0	22.5
6	10640.00	48.6 AV	54.0	-5.4	1.73 H	216	26.1	22.5

ANTENNA POLARITY & TEST DISTANCE: VERTICAL AT 3 M

NO.	FREQ. (MHz)	EMISSION LEVEL (dBuV/m)	LIMIT (dBuV/m)	MARGIN (dB)	ANTENNA HEIGHT (m)	TABLE ANGLE (Degree)	RAW VALUE (dBuV)	CORRECTION FACTOR (dB/m)
1	*5320.00	112.4 PK			1.33 V	215	71.8	40.6
2	*5320.00	102.0 AV			1.33 V	215	61.4	40.6
3	5350.00	64.6 PK	74.0	-9.4	1.33 V	215	52.7	11.9
4	5350.00	53.9 AV	54.0	-0.1	1.33 V	215	42.0	11.9
5	10640.00	62.0 PK	74.0	-12.0	2.64 V	188	39.5	22.5
6	10640.00	48.9 AV	54.0	-5.1	2.64 V	188	26.4	22.5

Remarks:

1. Emission Level(dBuV/m) = Raw Value(dBuV) + Correction Factor(dB/m)
2. Correction Factor(dB/m) = Antenna Factor(dB/m) + Cable Factor(dB) – Pre-Amplifier Factor(dB)
3. The other emission levels were very low against the limit
4. Margin value = Emission Level – Limit value
5. " * ": Fundamental frequency
6. " # ": The radiated frequency is out of the restricted band

CHANNEL	TX Channel 100	DETECTOR FUNCTION	Peak (PK)
FREQUENCY RANGE	1GHz ~ 40GHz		Average (AV)

ANTENNA POLARITY & TEST DISTANCE: HORIZONTAL AT 3 M

NO.	FREQ. (MHz)	EMISSION LEVEL (dBuV/m)	LIMIT (dBuV/m)	MARGIN (dB)	ANTENNA HEIGHT (m)	TABLE ANGLE (Degree)	RAW VALUE (dBuV)	CORRECTION FACTOR (dB/m)
1	5460.00	61.4 PK	74.0	-12.6	1.14 H	237	48.9	12.5
2	5460.00	51.3 AV	54.0	-2.7	1.14 H	237	38.8	12.5
3	#5470.00	62.8 PK	68.2	-5.4	1.14 H	237	50.3	12.5
4	*5500.00	112.2 PK			1.14 H	237	70.7	41.5
5	*5500.00	101.0 AV			1.14 H	237	59.5	41.5
6	11000.00	61.7 PK	74.0	-12.3	2.10 H	143	39.0	22.7
7	11000.00	49.5 AV	54.0	-4.5	2.10 H	143	26.8	22.7

ANTENNA POLARITY & TEST DISTANCE: VERTICAL AT 3 M

NO.	FREQ. (MHz)	EMISSION LEVEL (dBuV/m)	LIMIT (dBuV/m)	MARGIN (dB)	ANTENNA HEIGHT (m)	TABLE ANGLE (Degree)	RAW VALUE (dBuV)	CORRECTION FACTOR (dB/m)
1	5460.00	62.0 PK	74.0	-12.0	1.19 V	224	49.5	12.5
2	5460.00	51.7 AV	54.0	-2.3	1.19 V	224	39.2	12.5
3	#5470.00	67.8 PK	68.2	-0.4	1.19 V	224	55.3	12.5
4	*5500.00	115.4 PK			1.19 V	224	73.9	41.5
5	*5500.00	105.5 AV			1.19 V	224	64.0	41.5
6	11000.00	62.2 PK	74.0	-11.8	1.63 V	197	39.5	22.7
7	11000.00	49.8 AV	54.0	-4.2	1.63 V	197	27.1	22.7

Remarks:

1. Emission Level(dBuV/m) = Raw Value(dBuV) + Correction Factor(dB/m)
2. Correction Factor(dB/m) = Antenna Factor(dB/m) + Cable Factor(dB) – Pre-Amplifier Factor(dB)
3. The other emission levels were very low against the limit
4. Margin value = Emission Level – Limit value
5. " * ": Fundamental frequency
6. " # ": The radiated frequency is out of the restricted band

CHANNEL	TX Channel 116	DETECTOR FUNCTION	Peak (PK)
FREQUENCY RANGE	1GHz ~ 40GHz		Average (AV)

ANTENNA POLARITY & TEST DISTANCE: HORIZONTAL AT 3 M								
NO.	FREQ. (MHz)	EMISSION LEVEL (dBuV/m)	LIMIT (dBuV/m)	MARGIN (dB)	ANTENNA HEIGHT (m)	TABLE ANGLE (Degree)	RAW VALUE (dBuV)	CORRECTION FACTOR (dB/m)
1	*5580.00	114.3 PK			1.19 H	241	72.5	41.8
2	*5580.00	104.1 AV			1.19 H	241	62.3	41.8
3	11160.00	62.2 PK	74.0	-11.8	1.98 H	230	39.5	22.7
4	11160.00	49.5 AV	54.0	-4.5	1.98 H	230	26.8	22.7
ANTENNA POLARITY & TEST DISTANCE: VERTICAL AT 3 M								
NO.	FREQ. (MHz)	EMISSION LEVEL (dBuV/m)	LIMIT (dBuV/m)	MARGIN (dB)	ANTENNA HEIGHT (m)	TABLE ANGLE (Degree)	RAW VALUE (dBuV)	CORRECTION FACTOR (dB/m)
1	*5580.00	117.7 PK			1.20 V	221	75.9	41.8
2	*5580.00	107.5 AV			1.20 V	221	65.7	41.8
3	11160.00	62.7 PK	74.0	-11.3	2.11 V	302	40.0	22.7
4	11160.00	49.5 AV	54.0	-4.5	2.11 V	302	26.8	22.7

Remarks:

1. Emission Level(dBuV/m) = Raw Value(dBuV) + Correction Factor(dB/m)
2. Correction Factor(dB/m) = Antenna Factor(dB/m) + Cable Factor(dB) – Pre-Amplifier Factor(dB)
3. The other emission levels were very low against the limit
4. Margin value = Emission Level – Limit value
5. " * ": Fundamental frequency
6. " # ": The radiated frequency is out of the restricted band

CHANNEL	TX Channel 140	DETECTOR FUNCTION	Peak (PK)
FREQUENCY RANGE	1GHz ~ 40GHz		Average (AV)

ANTENNA POLARITY & TEST DISTANCE: HORIZONTAL AT 3 M

NO.	FREQ. (MHz)	EMISSION LEVEL (dBuV/m)	LIMIT (dBuV/m)	MARGIN (dB)	ANTENNA HEIGHT (m)	TABLE ANGLE (Degree)	RAW VALUE (dBuV)	CORRECTION FACTOR (dB/m)
1	*5700.00	114.7 PK			1.12 H	235	72.6	42.1
2	*5700.00	104.5 AV			1.12 H	235	62.4	42.1
3	#5725.00	64.4 PK	68.2	-3.8	1.12 H	235	51.6	12.8
4	11400.00	62.7 PK	74.0	-11.3	2.11 H	193	38.9	23.8
5	11400.00	50.2 AV	54.0	-3.8	2.11 H	193	26.4	23.8

ANTENNA POLARITY & TEST DISTANCE: VERTICAL AT 3 M

NO.	FREQ. (MHz)	EMISSION LEVEL (dBuV/m)	LIMIT (dBuV/m)	MARGIN (dB)	ANTENNA HEIGHT (m)	TABLE ANGLE (Degree)	RAW VALUE (dBuV)	CORRECTION FACTOR (dB/m)
1	*5700.00	117.3 PK			1.18 V	217	75.2	42.1
2	*5700.00	106.9 AV			1.18 V	217	64.8	42.1
3	#5725.00	67.7 PK	68.2	-0.5	1.18 V	217	54.9	12.8
4	11400.00	63.8 PK	74.0	-10.2	1.95 V	261	40.0	23.8
5	11400.00	50.6 AV	54.0	-3.4	1.95 V	261	26.8	23.8

Remarks:

1. Emission Level(dBuV/m) = Raw Value(dBuV) + Correction Factor(dB/m)
2. Correction Factor(dB/m) = Antenna Factor(dB/m) + Cable Factor(dB) – Pre-Amplifier Factor(dB)
3. The other emission levels were very low against the limit
4. Margin value = Emission Level – Limit value
5. " * ": Fundamental frequency
6. " # ": The radiated frequency is out of the restricted band

CHANNEL	TX Channel 144	DETECTOR FUNCTION	Peak (PK)
FREQUENCY RANGE	1GHz ~ 40GHz		Average (AV)

ANTENNA POLARITY & TEST DISTANCE: HORIZONTAL AT 3 M

NO.	FREQ. (MHz)	EMISSION LEVEL (dBuV/m)	LIMIT (dBuV/m)	MARGIN (dB)	ANTENNA HEIGHT (m)	TABLE ANGLE (Degree)	RAW VALUE (dBuV)	CORRECTION FACTOR (dB/m)
1	#5470.00	61.1 PK	68.2	-7.1	1.16 H	240	48.6	12.5
2	*5720.00	114.6 PK			1.16 H	240	72.5	42.1
3	*5720.00	104.5 AV			1.16 H	240	62.4	42.1
4	#5850.00	61.8 PK	68.2	-6.4	1.16 H	240	48.0	13.8
5	11440.00	62.5 PK	74.0	-11.5	2.99 H	154	38.9	23.6
6	11440.00	49.9 AV	54.0	-4.1	2.99 H	154	26.3	23.6

ANTENNA POLARITY & TEST DISTANCE: VERTICAL AT 3 M

NO.	FREQ. (MHz)	EMISSION LEVEL (dBuV/m)	LIMIT (dBuV/m)	MARGIN (dB)	ANTENNA HEIGHT (m)	TABLE ANGLE (Degree)	RAW VALUE (dBuV)	CORRECTION FACTOR (dB/m)
1	#5470.00	60.4 PK	68.2	-7.8	1.16 V	201	47.9	12.5
2	*5720.00	116.3 PK			1.16 V	201	74.2	42.1
3	*5720.00	106.1 AV			1.16 V	201	64.0	42.1
4	#5850.00	61.4 PK	68.2	-6.8	1.16 V	201	47.6	13.8
5	11440.00	62.1 PK	74.0	-11.9	2.05 V	103	38.5	23.6
6	11440.00	49.4 AV	54.0	-4.6	2.05 V	103	25.8	23.6

Remarks:

1. Emission Level(dBuV/m) = Raw Value(dBuV) + Correction Factor(dB/m)
2. Correction Factor(dB/m) = Antenna Factor(dB/m) + Cable Factor(dB) – Pre-Amplifier Factor(dB)
3. The other emission levels were very low against the limit
4. Margin value = Emission Level – Limit value
5. " * ": Fundamental frequency
6. " # ": The radiated frequency is out of the restricted band

802.11n (HT20)

CHANNEL	TX Channel 52	DETECTOR FUNCTION	Peak (PK)
FREQUENCY RANGE	1GHz ~ 40GHz		Average (AV)

ANTENNA POLARITY & TEST DISTANCE: HORIZONTAL AT 3 M

NO.	FREQ. (MHz)	EMISSION LEVEL (dBuV/m)	LIMIT (dBuV/m)	MARGIN (dB)	ANTENNA HEIGHT (m)	TABLE ANGLE (Degree)	RAW VALUE (dBuV)	CORRECTION FACTOR (dB/m)
1	5150.00	59.4 PK	74.0	-14.6	1.19 H	236	47.6	11.8
2	5150.00	46.6 AV	54.0	-7.4	1.19 H	236	34.8	11.8
3	*5260.00	113.2 PK			1.19 H	236	72.7	40.5
4	*5260.00	101.9 AV			1.19 H	236	61.4	40.5
5	#10520.00	61.1 PK	68.2	-7.1	2.91 H	143	38.8	22.3

ANTENNA POLARITY & TEST DISTANCE: VERTICAL AT 3 M

NO.	FREQ. (MHz)	EMISSION LEVEL (dBuV/m)	LIMIT (dBuV/m)	MARGIN (dB)	ANTENNA HEIGHT (m)	TABLE ANGLE (Degree)	RAW VALUE (dBuV)	CORRECTION FACTOR (dB/m)
1	5150.00	59.8 PK	74.0	-14.2	1.34 V	186	48.0	11.8
2	5150.00	46.4 AV	54.0	-7.6	1.34 V	186	34.6	11.8
3	*5260.00	114.0 PK			1.34 V	186	73.5	40.5
4	*5260.00	103.8 AV			1.34 V	186	63.3	40.5
5	#10520.00	61.5 PK	68.2	-6.7	1.75 V	230	39.2	22.3

Remarks:

1. Emission Level(dBuV/m) = Raw Value(dBuV) + Correction Factor(dB/m)
2. Correction Factor(dB/m) = Antenna Factor(dB/m) + Cable Factor(dB) – Pre-Amplifier Factor(dB)
3. The other emission levels were very low against the limit
4. Margin value = Emission Level – Limit value
5. " * ": Fundamental frequency
6. " # ": The radiated frequency is out of the restricted band

CHANNEL	TX Channel 60	DETECTOR FUNCTION	Peak (PK)
FREQUENCY RANGE	1GHz ~ 40GHz		Average (AV)

ANTENNA POLARITY & TEST DISTANCE: HORIZONTAL AT 3 M								
NO.	FREQ. (MHz)	EMISSION LEVEL (dBuV/m)	LIMIT (dBuV/m)	MARGIN (dB)	ANTENNA HEIGHT (m)	TABLE ANGLE (Degree)	RAW VALUE (dBuV)	CORRECTION FACTOR (dB/m)
1	*5300.00	113.2 PK			1.24 H	237	72.8	40.4
2	*5300.00	102.6 AV			1.24 H	237	62.2	40.4
3	10600.00	61.3 PK	74.0	-12.7	1.63 H	225	39.0	22.3
4	10600.00	48.7 AV	54.0	-5.3	1.63 H	225	26.4	22.3
ANTENNA POLARITY & TEST DISTANCE: VERTICAL AT 3 M								
NO.	FREQ. (MHz)	EMISSION LEVEL (dBuV/m)	LIMIT (dBuV/m)	MARGIN (dB)	ANTENNA HEIGHT (m)	TABLE ANGLE (Degree)	RAW VALUE (dBuV)	CORRECTION FACTOR (dB/m)
1	*5300.00	114.4 PK			1.33 V	200	74.0	40.4
2	*5300.00	104.0 AV			1.33 V	200	63.6	40.4
3	10600.00	61.8 PK	74.0	-12.2	1.68 V	241	39.5	22.3
4	10600.00	49.0 AV	54.0	-5.0	1.68 V	241	26.7	22.3

Remarks:

1. Emission Level(dBuV/m) = Raw Value(dBuV) + Correction Factor(dB/m)
2. Correction Factor(dB/m) = Antenna Factor(dB/m) + Cable Factor(dB) – Pre-Amplifier Factor(dB)
3. The other emission levels were very low against the limit
4. Margin value = Emission Level – Limit value
5. " * ": Fundamental frequency
6. " # ": The radiated frequency is out of the restricted band

CHANNEL	TX Channel 64	DETECTOR FUNCTION	Peak (PK)
FREQUENCY RANGE	1GHz ~ 40GHz		Average (AV)

ANTENNA POLARITY & TEST DISTANCE: HORIZONTAL AT 3 M

NO.	FREQ. (MHz)	EMISSION LEVEL (dBuV/m)	LIMIT (dBuV/m)	MARGIN (dB)	ANTENNA HEIGHT (m)	TABLE ANGLE (Degree)	RAW VALUE (dBuV)	CORRECTION FACTOR (dB/m)
1	*5320.00	110.6 PK			1.21 H	231	70.0	40.6
2	*5320.00	100.0 AV			1.21 H	231	59.4	40.6
3	5350.00	63.4 PK	74.0	-10.6	1.21 H	231	51.5	11.9
4	5350.00	51.1 AV	54.0	-2.9	1.21 H	231	39.2	11.9
5	10640.00	61.8 PK	74.0	-12.2	1.99 H	263	39.3	22.5
6	10640.00	48.7 AV	54.0	-5.3	1.99 H	263	26.2	22.5

ANTENNA POLARITY & TEST DISTANCE: VERTICAL AT 3 M

NO.	FREQ. (MHz)	EMISSION LEVEL (dBuV/m)	LIMIT (dBuV/m)	MARGIN (dB)	ANTENNA HEIGHT (m)	TABLE ANGLE (Degree)	RAW VALUE (dBuV)	CORRECTION FACTOR (dB/m)
1	*5320.00	112.0 PK			1.34 V	198	71.4	40.6
2	*5320.00	101.8 AV			1.34 V	198	61.2	40.6
3	5350.00	64.8 PK	74.0	-9.2	1.34 V	198	52.9	11.9
4	5350.00	53.5 AV	54.0	-0.5	1.34 V	198	41.6	11.9
5	10640.00	62.2 PK	74.0	-11.8	2.33 V	178	39.7	22.5
6	10640.00	49.0 AV	54.0	-5.0	2.33 V	178	26.5	22.5

Remarks:

1. Emission Level(dBuV/m) = Raw Value(dBuV) + Correction Factor(dB/m)
2. Correction Factor(dB/m) = Antenna Factor(dB/m) + Cable Factor(dB) – Pre-Amplifier Factor(dB)
3. The other emission levels were very low against the limit
4. Margin value = Emission Level – Limit value
5. " * ": Fundamental frequency
6. " # ": The radiated frequency is out of the restricted band

CHANNEL	TX Channel 100	DETECTOR FUNCTION	Peak (PK)
FREQUENCY RANGE	1GHz ~ 40GHz		Average (AV)

ANTENNA POLARITY & TEST DISTANCE: HORIZONTAL AT 3 M

NO.	FREQ. (MHz)	EMISSION LEVEL (dBuV/m)	LIMIT (dBuV/m)	MARGIN (dB)	ANTENNA HEIGHT (m)	TABLE ANGLE (Degree)	RAW VALUE (dBuV)	CORRECTION FACTOR (dB/m)
1	5460.00	61.6 PK	74.0	-12.4	1.20 H	235	49.1	12.5
2	5460.00	50.5 AV	54.0	-3.5	1.20 H	235	38.0	12.5
3	#5470.00	64.0 PK	68.2	-4.2	1.20 H	235	51.5	12.5
4	*5500.00	113.5 PK			1.20 H	235	72.0	41.5
5	*5500.00	103.3 AV			1.20 H	235	61.8	41.5
6	11000.00	61.9 PK	74.0	-12.1	2.05 H	171	39.2	22.7
7	11000.00	49.0 AV	54.0	-5.0	2.05 H	171	26.3	22.7

ANTENNA POLARITY & TEST DISTANCE: VERTICAL AT 3 M

NO.	FREQ. (MHz)	EMISSION LEVEL (dBuV/m)	LIMIT (dBuV/m)	MARGIN (dB)	ANTENNA HEIGHT (m)	TABLE ANGLE (Degree)	RAW VALUE (dBuV)	CORRECTION FACTOR (dB/m)
1	5460.00	62.3 PK	74.0	-11.7	1.08 V	227	49.8	12.5
2	5460.00	50.8 AV	54.0	-3.2	1.08 V	227	38.3	12.5
3	#5470.00	66.5 PK	68.2	-1.7	1.08 V	227	54.0	12.5
4	*5500.00	115.6 PK			1.08 V	227	74.1	41.5
5	*5500.00	105.7 AV			1.08 V	227	64.2	41.5
6	11000.00	62.6 PK	74.0	-11.4	1.27 V	230	39.9	22.7
7	11000.00	49.4 AV	54.0	-4.6	1.27 V	230	26.7	22.7

Remarks:

1. Emission Level(dBuV/m) = Raw Value(dBuV) + Correction Factor(dB/m)
2. Correction Factor(dB/m) = Antenna Factor(dB/m) + Cable Factor(dB) – Pre-Amplifier Factor(dB)
3. The other emission levels were very low against the limit
4. Margin value = Emission Level – Limit value
5. " * ": Fundamental frequency
6. " # ": The radiated frequency is out of the restricted band

CHANNEL	TX Channel 116	DETECTOR FUNCTION	Peak (PK)
FREQUENCY RANGE	1GHz ~ 40GHz		Average (AV)

ANTENNA POLARITY & TEST DISTANCE: HORIZONTAL AT 3 M								
NO.	FREQ. (MHz)	EMISSION LEVEL (dBuV/m)	LIMIT (dBuV/m)	MARGIN (dB)	ANTENNA HEIGHT (m)	TABLE ANGLE (Degree)	RAW VALUE (dBuV)	CORRECTION FACTOR (dB/m)
1	*5580.00	113.9 PK			1.17 H	231	72.1	41.8
2	*5580.00	103.8 AV			1.17 H	231	62.0	41.8
3	11160.00	61.9 PK	74.0	-12.1	1.62 H	114	39.2	22.7
4	11160.00	49.0 AV	54.0	-5.0	1.62 H	114	26.3	22.7
ANTENNA POLARITY & TEST DISTANCE: VERTICAL AT 3 M								
NO.	FREQ. (MHz)	EMISSION LEVEL (dBuV/m)	LIMIT (dBuV/m)	MARGIN (dB)	ANTENNA HEIGHT (m)	TABLE ANGLE (Degree)	RAW VALUE (dBuV)	CORRECTION FACTOR (dB/m)
1	*5580.00	116.2 PK			1.15 V	219	74.4	41.8
2	*5580.00	106.1 AV			1.15 V	219	64.3	41.8
3	11160.00	62.8 PK	74.0	-11.2	1.63 V	297	40.1	22.7
4	11160.00	49.5 AV	54.0	-4.5	1.63 V	297	26.8	22.7

Remarks:

1. Emission Level(dBuV/m) = Raw Value(dBuV) + Correction Factor(dB/m)
2. Correction Factor(dB/m) = Antenna Factor(dB/m) + Cable Factor(dB) – Pre-Amplifier Factor(dB)
3. The other emission levels were very low against the limit
4. Margin value = Emission Level – Limit value
5. " * ": Fundamental frequency
6. " # ": The radiated frequency is out of the restricted band

CHANNEL	TX Channel 140	DETECTOR FUNCTION	Peak (PK)
FREQUENCY RANGE	1GHz ~ 40GHz		Average (AV)

ANTENNA POLARITY & TEST DISTANCE: HORIZONTAL AT 3 M

NO.	FREQ. (MHz)	EMISSION LEVEL (dBuV/m)	LIMIT (dBuV/m)	MARGIN (dB)	ANTENNA HEIGHT (m)	TABLE ANGLE (Degree)	RAW VALUE (dBuV)	CORRECTION FACTOR (dB/m)
1	*5700.00	114.0 PK			1.15 H	239	71.9	42.1
2	*5700.00	103.5 AV			1.15 H	239	61.4	42.1
3	#5725.00	65.1 PK	68.2	-3.1	1.15 H	239	52.3	12.8
4	11400.00	62.8 PK	74.0	-11.2	2.91 H	183	39.0	23.8
5	11400.00	50.5 AV	54.0	-3.5	2.91 H	183	26.7	23.8

ANTENNA POLARITY & TEST DISTANCE: VERTICAL AT 3 M

NO.	FREQ. (MHz)	EMISSION LEVEL (dBuV/m)	LIMIT (dBuV/m)	MARGIN (dB)	ANTENNA HEIGHT (m)	TABLE ANGLE (Degree)	RAW VALUE (dBuV)	CORRECTION FACTOR (dB/m)
1	*5700.00	115.8 PK			1.21 V	214	73.7	42.1
2	*5700.00	105.8 AV			1.21 V	214	63.7	42.1
3	#5725.00	67.2 PK	68.2	-1.0	1.21 V	214	54.4	12.8
4	11400.00	64.0 PK	74.0	-10.0	2.52 V	143	40.2	23.8
5	11400.00	50.7 AV	54.0	-3.3	2.52 V	143	26.9	23.8

Remarks:

1. Emission Level(dBuV/m) = Raw Value(dBuV) + Correction Factor(dB/m)
2. Correction Factor(dB/m) = Antenna Factor(dB/m) + Cable Factor(dB) – Pre-Amplifier Factor(dB)
3. The other emission levels were very low against the limit
4. Margin value = Emission Level – Limit value
5. " * ": Fundamental frequency
6. " # ": The radiated frequency is out of the restricted band

CHANNEL	TX Channel 144	DETECTOR FUNCTION	Peak (PK)
FREQUENCY RANGE	1GHz ~ 40GHz		Average (AV)

ANTENNA POLARITY & TEST DISTANCE: HORIZONTAL AT 3 M

NO.	FREQ. (MHz)	EMISSION LEVEL (dBuV/m)	LIMIT (dBuV/m)	MARGIN (dB)	ANTENNA HEIGHT (m)	TABLE ANGLE (Degree)	RAW VALUE (dBuV)	CORRECTION FACTOR (dB/m)
1	#5470.00	60.7 PK	68.2	-7.5	1.13 H	231	48.2	12.5
2	*5720.00	114.0 PK			1.13 H	231	71.9	42.1
3	*5720.00	103.9 AV			1.13 H	231	61.8	42.1
4	#5850.00	62.0 PK	68.2	-6.2	1.13 H	231	48.2	13.8
5	11440.00	62.6 PK	74.0	-11.4	2.84 H	193	39.0	23.6
6	11440.00	50.4 AV	54.0	-3.6	2.84 H	193	26.8	23.6

ANTENNA POLARITY & TEST DISTANCE: VERTICAL AT 3 M

NO.	FREQ. (MHz)	EMISSION LEVEL (dBuV/m)	LIMIT (dBuV/m)	MARGIN (dB)	ANTENNA HEIGHT (m)	TABLE ANGLE (Degree)	RAW VALUE (dBuV)	CORRECTION FACTOR (dB/m)
1	#5470.00	60.4 PK	68.2	-7.8	1.17 V	209	47.9	12.5
2	*5720.00	115.4 PK			1.17 V	209	73.3	42.1
3	*5720.00	105.0 AV			1.17 V	209	62.9	42.1
4	#5850.00	62.5 PK	68.2	-5.7	1.17 V	209	48.7	13.8
5	11440.00	63.4 PK	74.0	-10.6	1.67 V	268	39.8	23.6
6	11440.00	50.7 AV	54.0	-3.3	1.67 V	268	27.1	23.6

Remarks:

1. Emission Level(dBuV/m) = Raw Value(dBuV) + Correction Factor(dB/m)
2. Correction Factor(dB/m) = Antenna Factor(dB/m) + Cable Factor(dB) – Pre-Amplifier Factor(dB)
3. The other emission levels were very low against the limit
4. Margin value = Emission Level – Limit value
5. " * ": Fundamental frequency
6. " # ": The radiated frequency is out of the restricted band

802.11n (HT40)

CHANNEL	TX Channel 54	DETECTOR FUNCTION	Peak (PK)
FREQUENCY RANGE	1GHz ~ 40GHz		Average (AV)

ANTENNA POLARITY & TEST DISTANCE: HORIZONTAL AT 3 M								
NO.	FREQ. (MHz)	EMISSION LEVEL (dBuV/m)	LIMIT (dBuV/m)	MARGIN (dB)	ANTENNA HEIGHT (m)	TABLE ANGLE (Degree)	RAW VALUE (dBuV)	CORRECTION FACTOR (dB/m)
1	5150.00	58.6 PK	74.0	-15.4	1.35 H	229	46.8	11.8
2	5150.00	46.3 AV	54.0	-7.7	1.35 H	229	34.5	11.8
3	*5270.00	109.8 PK			1.35 H	229	69.4	40.4
4	*5270.00	99.7 AV			1.35 H	229	59.3	40.4
5	#10540.00	61.0 PK	68.2	-7.2	2.18 H	147	38.8	22.2

ANTENNA POLARITY & TEST DISTANCE: VERTICAL AT 3 M								
NO.	FREQ. (MHz)	EMISSION LEVEL (dBuV/m)	LIMIT (dBuV/m)	MARGIN (dB)	ANTENNA HEIGHT (m)	TABLE ANGLE (Degree)	RAW VALUE (dBuV)	CORRECTION FACTOR (dB/m)
1	5150.00	59.7 PK	74.0	-14.3	1.30 V	225	47.9	11.8
2	5150.00	46.7 AV	54.0	-7.3	1.30 V	225	34.9	11.8
3	*5270.00	111.6 PK			1.30 V	225	71.2	40.4
4	*5270.00	101.7 AV			1.30 V	225	61.3	40.4
5	#10540.00	61.4 PK	68.2	-6.8	1.79 V	245	39.2	22.2

Remarks:

1. Emission Level(dBuV/m) = Raw Value(dBuV) + Correction Factor(dB/m)
2. Correction Factor(dB/m) = Antenna Factor(dB/m) + Cable Factor(dB) – Pre-Amplifier Factor(dB)
3. The other emission levels were very low against the limit
4. Margin value = Emission Level – Limit value
5. " * ": Fundamental frequency
6. " # ": The radiated frequency is out of the restricted band

CHANNEL	TX Channel 62	DETECTOR FUNCTION	Peak (PK)
FREQUENCY RANGE	1GHz ~ 40GHz		Average (AV)

ANTENNA POLARITY & TEST DISTANCE: HORIZONTAL AT 3 M

NO.	FREQ. (MHz)	EMISSION LEVEL (dBuV/m)	LIMIT (dBuV/m)	MARGIN (dB)	ANTENNA HEIGHT (m)	TABLE ANGLE (Degree)	RAW VALUE (dBuV)	CORRECTION FACTOR (dB/m)
1	*5310.00	109.4 PK			1.20 H	229	68.9	40.5
2	*5310.00	99.3 AV			1.20 H	229	58.8	40.5
3	5350.00	62.0 PK	74.0	-12.0	1.20 H	229	50.1	11.9
4	5350.00	49.0 AV	54.0	-5.0	1.20 H	229	37.1	11.9
5	10620.00	60.9 PK	74.0	-13.1	1.93 H	271	38.6	22.3
6	10620.00	48.7 AV	54.0	-5.3	1.93 H	271	26.4	22.3

ANTENNA POLARITY & TEST DISTANCE: VERTICAL AT 3 M

NO.	FREQ. (MHz)	EMISSION LEVEL (dBuV/m)	LIMIT (dBuV/m)	MARGIN (dB)	ANTENNA HEIGHT (m)	TABLE ANGLE (Degree)	RAW VALUE (dBuV)	CORRECTION FACTOR (dB/m)
1	*5310.00	111.7 PK			1.14 V	222	71.2	40.5
2	*5310.00	101.6 AV			1.14 V	222	61.1	40.5
3	5350.00	68.9 PK	74.0	-5.1	1.14 V	222	57.0	11.9
4	5350.00	53.4 AV	54.0	-0.6	1.14 V	222	41.5	11.9
5	10620.00	61.2 PK	74.0	-12.8	2.41 V	187	38.9	22.3
6	10620.00	49.1 AV	54.0	-4.9	2.41 V	187	26.8	22.3

Remarks:

1. Emission Level(dBuV/m) = Raw Value(dBuV) + Correction Factor(dB/m)
2. Correction Factor(dB/m) = Antenna Factor(dB/m) + Cable Factor(dB) – Pre-Amplifier Factor(dB)
3. The other emission levels were very low against the limit
4. Margin value = Emission Level – Limit value
5. " * ": Fundamental frequency
6. " # ": The radiated frequency is out of the restricted band

CHANNEL	TX Channel 102	DETECTOR FUNCTION	Peak (PK)
FREQUENCY RANGE	1GHz ~ 40GHz		Average (AV)

ANTENNA POLARITY & TEST DISTANCE: HORIZONTAL AT 3 M

NO.	FREQ. (MHz)	EMISSION LEVEL (dBuV/m)	LIMIT (dBuV/m)	MARGIN (dB)	ANTENNA HEIGHT (m)	TABLE ANGLE (Degree)	RAW VALUE (dBuV)	CORRECTION FACTOR (dB/m)
1	5460.00	64.3 PK	74.0	-9.7	1.14 H	240	51.8	12.5
2	5460.00	51.1 AV	54.0	-2.9	1.14 H	240	38.6	12.5
3	#5470.00	65.4 PK	68.2	-2.8	1.14 H	240	52.9	12.5
4	*5510.00	110.8 PK			1.14 H	240	69.2	41.6
5	*5510.00	100.7 AV			1.14 H	240	59.1	41.6
6	11020.00	61.9 PK	74.0	-12.1	1.85 H	206	39.2	22.7
7	11020.00	49.2 AV	54.0	-4.8	1.85 H	206	26.5	22.7

ANTENNA POLARITY & TEST DISTANCE: VERTICAL AT 3 M

NO.	FREQ. (MHz)	EMISSION LEVEL (dBuV/m)	LIMIT (dBuV/m)	MARGIN (dB)	ANTENNA HEIGHT (m)	TABLE ANGLE (Degree)	RAW VALUE (dBuV)	CORRECTION FACTOR (dB/m)
1	5460.00	66.2 PK	74.0	-7.8	1.15 V	221	53.7	12.5
2	5460.00	51.8 AV	54.0	-2.2	1.15 V	221	39.3	12.5
3	#5470.00	67.6 PK	68.2	-0.6	1.15 V	221	55.1	12.5
4	*5510.00	113.2 PK			1.15 V	221	71.6	41.6
5	*5510.00	103.2 AV			1.15 V	221	61.6	41.6
6	11020.00	62.4 PK	74.0	-11.6	1.63 V	175	39.7	22.7
7	11020.00	49.5 AV	54.0	-4.5	1.63 V	175	26.8	22.7

Remarks:

1. Emission Level(dBuV/m) = Raw Value(dBuV) + Correction Factor(dB/m)
2. Correction Factor(dB/m) = Antenna Factor(dB/m) + Cable Factor(dB) – Pre-Amplifier Factor(dB)
3. The other emission levels were very low against the limit
4. Margin value = Emission Level – Limit value
5. " * ": Fundamental frequency
6. " # ": The radiated frequency is out of the restricted band

CHANNEL	TX Channel 110	DETECTOR FUNCTION	Peak (PK)
FREQUENCY RANGE	1GHz ~ 40GHz		Average (AV)

ANTENNA POLARITY & TEST DISTANCE: HORIZONTAL AT 3 M								
NO.	FREQ. (MHz)	EMISSION LEVEL (dBuV/m)	LIMIT (dBuV/m)	MARGIN (dB)	ANTENNA HEIGHT (m)	TABLE ANGLE (Degree)	RAW VALUE (dBuV)	CORRECTION FACTOR (dB/m)
1	*5550.00	111.8 PK			1.19 H	231	70.1	41.7
2	*5550.00	102.0 AV			1.19 H	231	60.3	41.7
3	11100.00	61.8 PK	74.0	-12.2	2.30 H	157	38.9	22.9
4	11100.00	49.6 AV	54.0	-4.4	2.30 H	157	26.7	22.9
ANTENNA POLARITY & TEST DISTANCE: VERTICAL AT 3 M								
NO.	FREQ. (MHz)	EMISSION LEVEL (dBuV/m)	LIMIT (dBuV/m)	MARGIN (dB)	ANTENNA HEIGHT (m)	TABLE ANGLE (Degree)	RAW VALUE (dBuV)	CORRECTION FACTOR (dB/m)
1	*5550.00	114.0 PK			1.15 V	219	72.3	41.7
2	*5550.00	103.9 AV			1.15 V	219	62.2	41.7
3	11100.00	62.5 PK	74.0	-11.5	1.98 V	230	39.6	22.9
4	11100.00	49.8 AV	54.0	-4.2	1.98 V	230	26.9	22.9

Remarks:

1. Emission Level(dBuV/m) = Raw Value(dBuV) + Correction Factor(dB/m)
2. Correction Factor(dB/m) = Antenna Factor(dB/m) + Cable Factor(dB) – Pre-Amplifier Factor(dB)
3. The other emission levels were very low against the limit
4. Margin value = Emission Level – Limit value
5. " * ": Fundamental frequency
6. " # ": The radiated frequency is out of the restricted band

CHANNEL	TX Channel 134	DETECTOR FUNCTION	Peak (PK)
FREQUENCY RANGE	1GHz ~ 40GHz		Average (AV)

ANTENNA POLARITY & TEST DISTANCE: HORIZONTAL AT 3 M

NO.	FREQ. (MHz)	EMISSION LEVEL (dBuV/m)	LIMIT (dBuV/m)	MARGIN (dB)	ANTENNA HEIGHT (m)	TABLE ANGLE (Degree)	RAW VALUE (dBuV)	CORRECTION FACTOR (dB/m)
1	*5670.00	111.8 PK			1.21 H	243	70.1	41.7
2	*5670.00	101.6 AV			1.21 H	243	59.9	41.7
3	#5725.00	65.1 PK	68.2	-3.1	1.21 H	243	52.3	12.8
4	11340.00	62.4 PK	74.0	-11.6	2.94 H	182	39.1	23.3
5	11340.00	49.5 AV	54.0	-4.5	2.94 H	182	26.2	23.3

ANTENNA POLARITY & TEST DISTANCE: VERTICAL AT 3 M

NO.	FREQ. (MHz)	EMISSION LEVEL (dBuV/m)	LIMIT (dBuV/m)	MARGIN (dB)	ANTENNA HEIGHT (m)	TABLE ANGLE (Degree)	RAW VALUE (dBuV)	CORRECTION FACTOR (dB/m)
1	*5670.00	114.0 PK			1.18 V	217	72.3	41.7
2	*5670.00	103.8 AV			1.18 V	217	62.1	41.7
3	#5725.00	67.7 PK	68.2	-0.5	1.18 V	217	54.9	12.8
4	11340.00	63.0 PK	74.0	-11.0	1.88 V	267	39.7	23.3
5	11340.00	49.8 AV	54.0	-4.2	1.88 V	267	26.5	23.3

Remarks:

1. Emission Level(dBuV/m) = Raw Value(dBuV) + Correction Factor(dB/m)
2. Correction Factor(dB/m) = Antenna Factor(dB/m) + Cable Factor(dB) – Pre-Amplifier Factor(dB)
3. The other emission levels were very low against the limit
4. Margin value = Emission Level – Limit value
5. " * ": Fundamental frequency
6. " # ": The radiated frequency is out of the restricted band

CHANNEL	TX Channel 142	DETECTOR FUNCTION	Peak (PK)
FREQUENCY RANGE	1GHz ~ 40GHz		Average (AV)

ANTENNA POLARITY & TEST DISTANCE: HORIZONTAL AT 3 M

NO.	FREQ. (MHz)	EMISSION LEVEL (dBuV/m)	LIMIT (dBuV/m)	MARGIN (dB)	ANTENNA HEIGHT (m)	TABLE ANGLE (Degree)	RAW VALUE (dBuV)	CORRECTION FACTOR (dB/m)
1	#5470.00	60.1 PK	68.2	-8.1	1.18 H	242	47.6	12.5
2	*5710.00	110.5 PK			1.18 H	242	68.4	42.1
3	*5710.00	100.3 AV			1.18 H	242	58.2	42.1
4	#5850.00	61.4 PK	68.2	-6.8	1.18 H	242	47.6	13.8
5	11420.00	62.7 PK	74.0	-11.3	3.15 H	142	38.9	23.8
6	11420.00	49.6 AV	54.0	-4.4	3.15 H	142	25.8	23.8

ANTENNA POLARITY & TEST DISTANCE: VERTICAL AT 3 M

NO.	FREQ. (MHz)	EMISSION LEVEL (dBuV/m)	LIMIT (dBuV/m)	MARGIN (dB)	ANTENNA HEIGHT (m)	TABLE ANGLE (Degree)	RAW VALUE (dBuV)	CORRECTION FACTOR (dB/m)
1	#5470.00	60.3 PK	68.2	-7.9	1.57 V	202	47.8	12.5
2	*5710.00	112.1 PK			1.57 V	202	70.0	42.1
3	*5710.00	102.5 AV			1.57 V	202	60.4	42.1
4	#5850.00	61.8 PK	68.2	-6.4	1.57 V	202	48.0	13.8
5	11420.00	63.0 PK	74.0	-11.0	2.47 V	116	39.2	23.8
6	11420.00	49.9 AV	54.0	-4.1	2.47 V	116	26.1	23.8

Remarks:

1. Emission Level(dBuV/m) = Raw Value(dBuV) + Correction Factor(dB/m)
2. Correction Factor(dB/m) = Antenna Factor(dB/m) + Cable Factor(dB) – Pre-Amplifier Factor(dB)
3. The other emission levels were very low against the limit
4. Margin value = Emission Level – Limit value
5. " * ": Fundamental frequency
6. " # ": The radiated frequency is out of the restricted band

802.11ac (VHT80)

CHANNEL	TX Channel 58	DETECTOR FUNCTION	Peak (PK)
FREQUENCY RANGE	1GHz ~ 40GHz		Average (AV)

ANTENNA POLARITY & TEST DISTANCE: HORIZONTAL AT 3 M								
NO.	FREQ. (MHz)	EMISSION LEVEL (dBuV/m)	LIMIT (dBuV/m)	MARGIN (dB)	ANTENNA HEIGHT (m)	TABLE ANGLE (Degree)	RAW VALUE (dBuV)	CORRECTION FACTOR (dB/m)
1	5150.00	60.1 PK	74.0	-13.9	1.15 H	238	48.3	11.8
2	5150.00	47.0 AV	54.0	-7.0	1.15 H	238	35.2	11.8
3	*5290.00	103.3 PK			1.15 H	238	62.9	40.4
4	*5290.00	93.7 AV			1.15 H	238	53.3	40.4
5	5350.00	63.0 PK	74.0	-11.0	1.15 H	238	51.1	11.9
6	5350.00	49.8 AV	54.0	-4.2	1.15 H	238	37.9	11.9
7	#10580.00	61.0 PK	68.2	-7.2	1.62 H	178	38.8	22.2

ANTENNA POLARITY & TEST DISTANCE: VERTICAL AT 3 M								
NO.	FREQ. (MHz)	EMISSION LEVEL (dBuV/m)	LIMIT (dBuV/m)	MARGIN (dB)	ANTENNA HEIGHT (m)	TABLE ANGLE (Degree)	RAW VALUE (dBuV)	CORRECTION FACTOR (dB/m)
1	5150.00	60.5 PK	74.0	-13.5	1.14 V	221	48.7	11.8
2	5150.00	47.4 AV	54.0	-6.6	1.14 V	221	35.6	11.8
3	*5290.00	106.5 PK			1.14 V	221	66.1	40.4
4	*5290.00	96.3 AV			1.14 V	221	55.9	40.4
5	5350.00	67.0 PK	74.0	-7.0	1.14 V	221	55.1	11.9
6	5350.00	53.9 AV	54.0	-0.1	1.14 V	221	42.0	11.9
7	#10580.00	61.3 PK	68.2	-6.9	2.66 V	154	39.1	22.2

Remarks:

1. Emission Level(dBuV/m) = Raw Value(dBuV) + Correction Factor(dB/m)
2. Correction Factor(dB/m) = Antenna Factor(dB/m) + Cable Factor(dB) – Pre-Amplifier Factor(dB)
3. The other emission levels were very low against the limit
4. Margin value = Emission Level – Limit value
5. " * ": Fundamental frequency
6. " # ": The radiated frequency is out of the restricted band

CHANNEL	TX Channel 106	DETECTOR FUNCTION	Peak (PK)
FREQUENCY RANGE	1GHz ~ 40GHz		Average (AV)

ANTENNA POLARITY & TEST DISTANCE: HORIZONTAL AT 3 M								
NO.	FREQ. (MHz)	EMISSION LEVEL (dBuV/m)	LIMIT (dBuV/m)	MARGIN (dB)	ANTENNA HEIGHT (m)	TABLE ANGLE (Degree)	RAW VALUE (dBuV)	CORRECTION FACTOR (dB/m)
1	5460.00	64.0 PK	74.0	-10.0	1.15 H	232	51.5	12.5
2	5460.00	51.9 AV	54.0	-2.1	1.15 H	232	39.4	12.5
3	#5470.00	64.6 PK	68.2	-3.6	1.15 H	232	52.1	12.5
4	*5530.00	104.8 PK			1.15 H	232	63.1	41.7
5	*5530.00	94.6 AV			1.15 H	232	52.9	41.7
6	#5725.00	61.2 PK	68.2	-7.0	1.15 H	232	48.4	12.8
7	11060.00	61.9 PK	74.0	-12.1	1.53 H	299	39.1	22.8
8	11060.00	49.5 AV	54.0	-4.5	1.53 H	299	26.7	22.8
ANTENNA POLARITY & TEST DISTANCE: VERTICAL AT 3 M								
NO.	FREQ. (MHz)	EMISSION LEVEL (dBuV/m)	LIMIT (dBuV/m)	MARGIN (dB)	ANTENNA HEIGHT (m)	TABLE ANGLE (Degree)	RAW VALUE (dBuV)	CORRECTION FACTOR (dB/m)
1	5460.00	66.1 PK	74.0	-7.9	1.17 V	217	53.6	12.5
2	5460.00	53.5 AV	54.0	-0.5	1.17 V	217	41.0	12.5
3	#5470.00	66.7 PK	68.2	-1.5	1.17 V	217	54.2	12.5
4	*5530.00	107.5 PK			1.17 V	217	65.8	41.7
5	*5530.00	98.0 AV			1.17 V	217	56.3	41.7
6	#5725.00	60.7 PK	68.2	-7.5	1.17 V	217	47.9	12.8
7	11060.00	62.3 PK	74.0	-11.7	2.17 V	146	39.5	22.8
8	11060.00	49.6 AV	54.0	-4.4	2.17 V	146	26.8	22.8

Remarks:

1. Emission Level(dBuV/m) = Raw Value(dBuV) + Correction Factor(dB/m)
2. Correction Factor(dB/m) = Antenna Factor(dB/m) + Cable Factor(dB) – Pre-Amplifier Factor(dB)
3. The other emission levels were very low against the limit
4. Margin value = Emission Level – Limit value
5. " * ": Fundamental frequency
6. " # ": The radiated frequency is out of the restricted band

CHANNEL	TX Channel 122	DETECTOR FUNCTION	Peak (PK)
FREQUENCY RANGE	1GHz ~ 40GHz		Average (AV)

ANTENNA POLARITY & TEST DISTANCE: HORIZONTAL AT 3 M								
NO.	FREQ. (MHz)	EMISSION LEVEL (dBuV/m)	LIMIT (dBuV/m)	MARGIN (dB)	ANTENNA HEIGHT (m)	TABLE ANGLE (Degree)	RAW VALUE (dBuV)	CORRECTION FACTOR (dB/m)
1	5460.00	63.0 PK	74.0	-11.0	1.20 H	235	50.5	12.5
2	5460.00	49.0 AV	54.0	-5.0	1.20 H	235	36.5	12.5
3	#5470.00	63.9 PK	68.2	-4.3	1.20 H	235	51.4	12.5
4	*5610.00	106.6 PK			1.20 H	235	64.9	41.7
5	*5610.00	96.4 AV			1.20 H	235	54.7	41.7
6	#5725.00	67.9 PK	68.2	-0.3	1.20 H	235	55.1	12.8
7	11220.00	61.5 PK	74.0	-12.5	2.53 H	144	38.9	22.6
8	11220.00	49.0 AV	54.0	-5.0	2.53 H	144	26.4	22.6
ANTENNA POLARITY & TEST DISTANCE: VERTICAL AT 3 M								
NO.	FREQ. (MHz)	EMISSION LEVEL (dBuV/m)	LIMIT (dBuV/m)	MARGIN (dB)	ANTENNA HEIGHT (m)	TABLE ANGLE (Degree)	RAW VALUE (dBuV)	CORRECTION FACTOR (dB/m)
1	5460.00	63.3 PK	74.0	-10.7	1.22 V	217	50.8	12.5
2	5460.00	49.0 AV	54.0	-5.0	1.22 V	217	36.5	12.5
3	#5470.00	64.1 PK	68.2	-4.1	1.22 V	217	51.6	12.5
4	*5610.00	110.9 PK			1.22 V	217	69.2	41.7
5	*5610.00	100.6 AV			1.22 V	217	58.9	41.7
6	#5725.00	67.2 PK	68.2	-1.0	1.22 V	217	54.4	12.8
7	11220.00	62.0 PK	74.0	-12.0	2.98 V	140	39.4	22.6
8	11220.00	49.2 AV	54.0	-4.8	2.98 V	140	26.6	22.6

Remarks:

1. Emission Level(dBuV/m) = Raw Value(dBuV) + Correction Factor(dB/m)
2. Correction Factor(dB/m) = Antenna Factor(dB/m) + Cable Factor(dB) – Pre-Amplifier Factor(dB)
3. The other emission levels were very low against the limit
4. Margin value = Emission Level – Limit value
5. " * ": Fundamental frequency
6. " # ": The radiated frequency is out of the restricted band

CHANNEL	TX Channel 138	DETECTOR FUNCTION	Peak (PK)
FREQUENCY RANGE	1GHz ~ 40GHz		Average (AV)

ANTENNA POLARITY & TEST DISTANCE: HORIZONTAL AT 3 M								
NO.	FREQ. (MHz)	EMISSION LEVEL (dBuV/m)	LIMIT (dBuV/m)	MARGIN (dB)	ANTENNA HEIGHT (m)	TABLE ANGLE (Degree)	RAW VALUE (dBuV)	CORRECTION FACTOR (dB/m)
1	#5470.00	60.5 PK	68.2	-7.7	1.14 H	236	48.0	12.5
2	*5690.00	108.1 PK			1.14 H	236	66.1	42.0
3	*5690.00	97.7 AV			1.14 H	236	55.7	42.0
4	#5850.00	62.7 PK	68.2	-5.5	1.14 H	236	48.9	13.8
5	11380.00	62.5 PK	74.0	-11.5	2.20 H	198	38.9	23.6
6	11380.00	50.4 AV	54.0	-3.6	2.20 H	198	26.8	23.6

ANTENNA POLARITY & TEST DISTANCE: VERTICAL AT 3 M								
NO.	FREQ. (MHz)	EMISSION LEVEL (dBuV/m)	LIMIT (dBuV/m)	MARGIN (dB)	ANTENNA HEIGHT (m)	TABLE ANGLE (Degree)	RAW VALUE (dBuV)	CORRECTION FACTOR (dB/m)
1	#5470.00	60.7 PK	68.2	-7.5	1.39 V	207	48.2	12.5
2	*5690.00	109.0 PK			1.39 V	207	67.0	42.0
3	*5690.00	99.1 AV			1.39 V	207	57.1	42.0
4	#5850.00	64.2 PK	68.2	-4.0	1.39 V	207	50.4	13.8
5	11380.00	62.9 PK	74.0	-11.1	2.28 V	183	39.3	23.6
6	11380.00	50.4 AV	54.0	-3.6	2.28 V	183	26.8	23.6

Remarks:

1. Emission Level(dBuV/m) = Raw Value(dBuV) + Correction Factor(dB/m)
2. Correction Factor(dB/m) = Antenna Factor(dB/m) + Cable Factor(dB) – Pre-Amplifier Factor(dB)
3. The other emission levels were very low against the limit
4. Margin value = Emission Level – Limit value
5. " * ": Fundamental frequency
6. " # ": The radiated frequency is out of the restricted band

Below 1GHz Worst-Case Data:

802.11a

CHANNEL	TX Channel 52	DETECTOR FUNCTION	Quasi-Peak (QP)
FREQUENCY RANGE	9kHz ~ 1GHz		

ANTENNA POLARITY & TEST DISTANCE: HORIZONTAL AT 3 M								
NO.	FREQ. (MHz)	EMISSION LEVEL (dBuV/m)	LIMIT (dBuV/m)	MARGIN (dB)	ANTENNA HEIGHT (m)	TABLE ANGLE (Degree)	RAW VALUE (dBuV)	CORRECTION FACTOR (dB/m)
1	35.72	32.0 QP	40.0	-8.0	1.00 H	108	42.0	-10.0
2	124.98	29.7 QP	43.5	-13.8	1.00 H	304	40.4	-10.7
3	291.85	21.9 QP	46.0	-24.1	1.00 H	347	30.0	-8.1
4	604.26	27.0 QP	46.0	-19.0	1.00 H	9	29.2	-2.2
5	730.38	35.1 QP	46.0	-10.9	1.00 H	19	34.6	0.5
6	932.19	33.0 QP	46.0	-13.0	1.00 H	31	28.9	4.1

Remarks:

1. Emission Level(dBuV/m) = Raw Value(dBuV) + Correction Factor(dB/m)
2. Correction Factor(dB/m) = Antenna Factor(dB/m) + Cable Factor(dB) – Pre-Amplifier Factor(dB)
3. The other emission levels were very low against the limit of frequency range 30MHz ~ 1000MHz
4. Margin value = Emission Level – Limit value
5. The emission levels were very low against the limit of frequency range 9kHz ~ 30MHz: the amplitude of spurious emissions attenuated more than 20 dB below the permissible value to be report

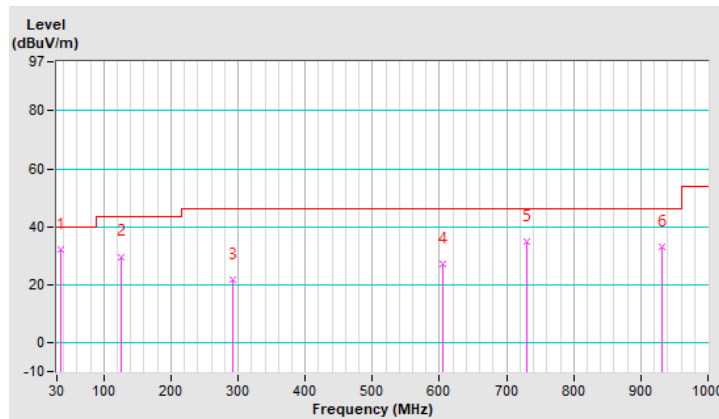

CHANNEL	TX Channel 52	DETECTOR FUNCTION	Quasi-Peak (QP)
FREQUENCY RANGE	9kHz ~ 1GHz		

ANTENNA POLARITY & TEST DISTANCE: VERTICAL AT 3 M								
NO.	FREQ. (MHz)	EMISSION LEVEL (dBuV/m)	LIMIT (dBuV/m)	MARGIN (dB)	ANTENNA HEIGHT (m)	TABLE ANGLE (Degree)	RAW VALUE (dBuV)	CORRECTION FACTOR (dB/m)
1	30.90	35.2 QP	40.0	-4.8	1.00 V	138	45.4	-10.2
2	59.01	35.9 QP	40.0	-4.1	1.00 V	9	44.7	-8.8
3	134.68	28.6 QP	43.5	-14.9	1.00 V	41	38.3	-9.7
4	600.38	27.7 QP	46.0	-18.3	1.00 V	347	30.0	-2.3
5	835.17	30.5 QP	46.0	-15.5	1.00 V	9	27.9	2.6
6	947.71	31.4 QP	46.0	-14.6	1.00 V	289	26.9	4.5

Remarks:

1. Emission Level(dBuV/m) = Raw Value(dBuV) + Correction Factor(dB/m)
2. Correction Factor(dB/m) = Antenna Factor(dB/m) + Cable Factor(dB) – Pre-Amplifier Factor(dB)
3. The other emission levels were very low against the limit of frequency range 30MHz ~ 1000MHz
4. Margin value = Emission Level – Limit value
5. The emission levels were very low against the limit of frequency range 9kHz ~ 30MHz: the amplitude of spurious emissions attenuated more than 20 dB below the permissible value to be report

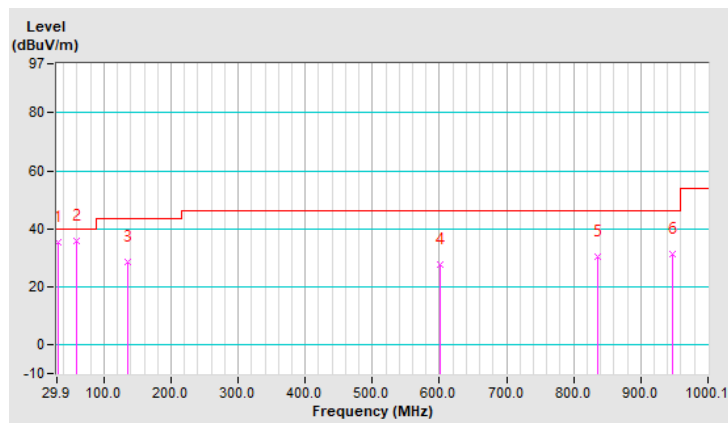

4.2 Conducted Emission Measurement

4.2.1 Limits of Conducted Emission Measurement

Frequency (MHz)	Conducted Limit (dBuV)	
	Quasi-peak	Average
0.15 - 0.5	66 - 56	56 - 46
0.50 - 5.0	56	46
5.0 - 30.0	60	50

Note: 1. The lower limit shall apply at the transition frequencies.

2. The limit decreases in line with the logarithm of the frequency in the range of 0.15 to 0.50MHz.

4.2.2 Test Instruments

Description & Manufacturer	Model No.	Serial No.	Cal. Date	Cal. Due
Test Receiver ROHDE & SCHWARZ	ESCS30	100291	Sep. 03, 2018	Sep. 02, 2019
RF signal cable Woken	5D-FB	Cable-cond1-01	Sep. 05, 2018	Sep. 04, 2019
LISN ROHDE & SCHWARZ (EUT)	ENV216	101826	Feb. 26, 2018	Feb. 25, 2019
LISN ROHDE & SCHWARZ (Peripheral)	ESH3-Z5	100311	Aug. 19, 2018	Aug. 18, 2019
Software ADT	BV ADT_Cond_ V7.3.7.4	NA	NA	NA

Note: 1. The calibration interval of the above test instruments is 12 months and the calibrations are traceable to NML/ROC and NIST/USA.

2. The test was performed in HwaYa Shielded Room 1.

3. The VCCI Site Registration No. is C-2040.

4.2.3 Test Procedures

- The EUT was placed 0.4 meters from the conducting wall of the shielded room with EUT being connected to the power mains through a line impedance stabilization network (LISN). Other support units were connected to the power mains through another LISN. The two LISNs provide 50 ohm/ 50uH of coupling impedance for the measuring instrument.
- Both lines of the power mains connected to the EUT were checked for maximum conducted interference.
- The frequency range from 150kHz to 30MHz was searched. Emission levels under (Limit - 20dB) was not recorded.

Note: The resolution bandwidth and video bandwidth of test receiver is 9kHz for quasi-peak detection (QP) and average detection (AV) at frequency 0.15MHz-30MHz.

4.2.4 Deviation from Test Standard

No deviation.

4.2.5 Test Setup

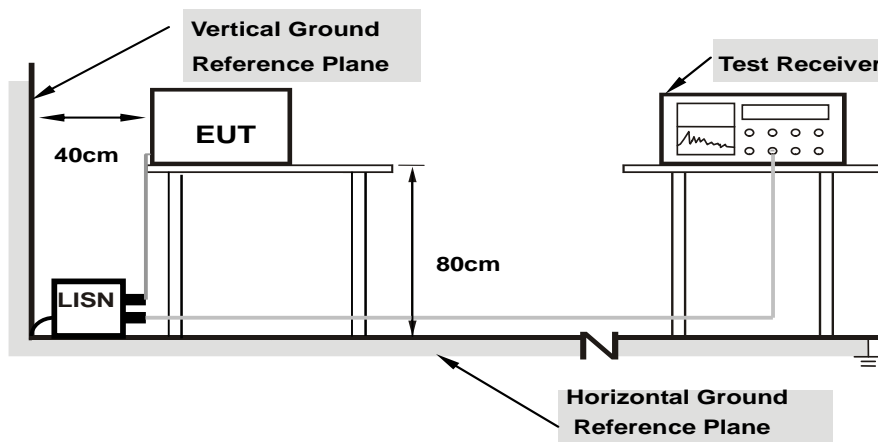

Note: 1.Support units were connected to second LISN.

For the actual test configuration, please refer to the attached file (Test Setup Photo).

4.2.6 EUT Operating Conditions

Same as 4.1.6.

4.2.7 Test Results

Worst-case data:

802.11a

Phase	Line (L)	Detector Function	Quasi-Peak (QP) / Average (AV)
-------	----------	-------------------	--------------------------------

No	Freq. [MHz]	Corr. Factor (dB)	Reading Value [dB (uV)]		Emission Level [dB (uV)]		Limit [dB (uV)]		Margin (dB)	
			Q.P.	AV.	Q.P.	AV.	Q.P.	AV.	Q.P.	AV.
			1	0.16564	9.67	38.83	25.97	48.50	35.64	65.18
2	0.56121	9.66	30.15	23.77	39.81	33.43	56.00	46.00	-16.19	-12.57
3	0.99847	9.65	19.90	12.55	29.55	22.20	56.00	46.00	-26.45	-23.80
4	2.32005	9.69	15.91	9.30	25.60	18.99	56.00	46.00	-30.40	-27.01
5	9.90936	9.85	23.63	17.69	33.48	27.54	60.00	50.00	-26.52	-22.46
6	18.51918	9.90	18.79	12.97	28.69	22.87	60.00	50.00	-31.31	-27.13

Remarks:

1. Q.P. and AV. are abbreviations of quasi-peak and average individually.
2. The emission levels of other frequencies were very low against the limit.
3. Margin value = Emission level - Limit value
4. Correction factor = Insertion loss + Cable loss
5. Emission Level = Correction Factor + Reading Value.

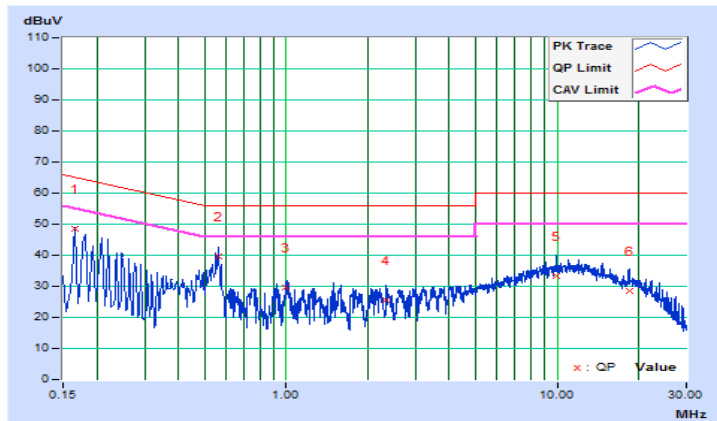

Phase	Neutral (N)	Detector Function	Quasi-Peak (QP) / Average (AV)
-------	-------------	-------------------	--------------------------------

No	Freq. [MHz]	Corr. Factor (dB)	Reading Value [dB (uV)]		Emission Level [dB (uV)]		Limit [dB (uV)]		Margin (dB)	
			Q.P.	AV.	Q.P.	AV.	Q.P.	AV.	Q.P.	AV.
			1	0.16955	9.68	38.11	23.16	47.79	32.84	64.98
2	0.28140	9.67	26.63	11.31	36.30	20.98	60.77	50.77	-24.47	-29.79
3	0.55679	9.66	28.50	22.38	38.16	32.04	56.00	46.00	-17.84	-13.96
4	1.49895	9.66	16.96	12.05	26.62	21.71	56.00	46.00	-29.38	-24.29
5	7.32876	9.80	18.32	12.53	28.12	22.33	60.00	50.00	-31.88	-27.67
6	17.48694	9.97	16.02	10.26	25.99	20.23	60.00	50.00	-34.01	-29.77

Remarks:

1. Q.P. and AV. are abbreviations of quasi-peak and average individually.
2. The emission levels of other frequencies were very low against the limit.
3. Margin value = Emission level - Limit value
4. Correction factor = Insertion loss + Cable loss
5. Emission Level = Correction Factor + Reading Value.

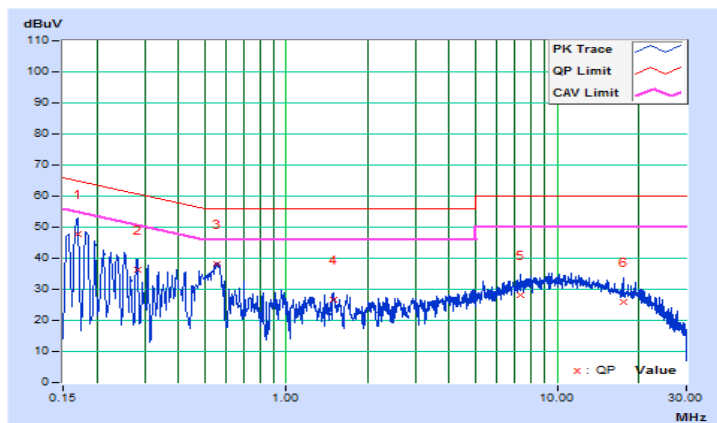

4.3 Transmit Power Measurement

4.3.1 Limits of Transmit Power Measurement

Operation Band	EUT Category	Limit
U-NII-1	Outdoor Access Point	1 Watt (30 dBm) (Max. e.i.r.p \leq 125mW(21 dBm) at any elevation angle above 30 degrees as measured from the horizon)
	Fixed point-to-point Access Point	1 Watt (30 dBm)
	Indoor Access Point	1 Watt (30 dBm)
	Mobile and Portable client device	250mW (24 dBm)
U-NII-2A	√	250mW (24 dBm) or 11 dBm+10 log B*
U-NII-2C	√	250mW (24 dBm) or 11 dBm+10 log B*
U-NII-3	√	1 Watt (30 dBm)

*B is the 26 dB emission bandwidth in megahertz

Per KDB 662911 Method of conducted output power measurement on IEEE 802.11 devices,

Array Gain = 0 dB (i.e., no array gain) for $N_{ANT} \leq 4$;

Array Gain = 0 dB (i.e., no array gain) for channel widths ≥ 40 MHz for any N_{ANT} ;

Array Gain = $5 \log(N_{ANT}/N_{SS})$ dB or 3 dB, whichever is less for 20-MHz channel widths with $N_{ANT} \geq 5$.

For power measurements on all other devices: Array Gain = $10 \log(N_{ANT}/N_{SS})$ dB.

4.3.2 Test Setup

For Power Output

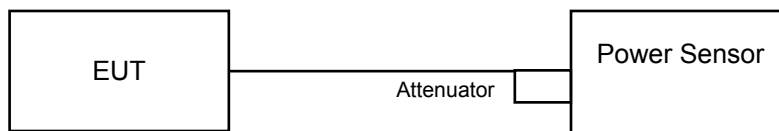

For 26dB Bandwidth

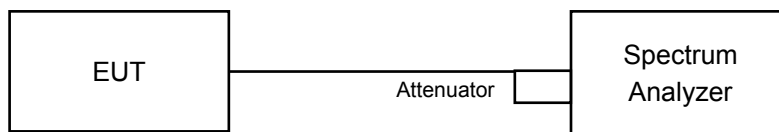

4.3.3 Test Instruments

Refer to section 4.1.2 to get information of above instrument.

4.3.4 Test Procedure

For Average Power Measurement

802.11a, 802.11n (HT20), 802.11n (HT40)

Method PM is used to perform output power measurement, trigger and gating function of wide band power meter is enabled to measure max output power of TX on burst and set the detector to average. Duty factor is not added to measured value.

For 26dB Bandwidth

- a. Set RBW = approximately 1% of the emission bandwidth.
- b. Set the VBW > RBW.
- c. Detector = Peak.
- d. Trace mode = max hold.
- e. Measure the maximum width of the emission that is 26 dB down from the peak of the emission. Compare this with the RBW setting of the analyzer. Readjust RBW and repeat measurement as needed until the RBW/EBW ratio is approximately 1%.

4.3.5 Deviation from Test Standard

No deviation.

4.3.6 EUT Operating Conditions

The software provided by client to enable the EUT under transmission condition continuously at lowest, middle and highest channel frequencies individually.

4.3.7 Test Result

Power Output:

CDD Mode

802.11a

Chan.	Freq. (MHz)	Average Power (dBm)			Total Power (mW)	Total Power (dBm)	Power Limit (dBm)	Pass / Fail
		Chain 0	Chain 1	Chain 2				
52	5260	18.67	18.74	18.62	221.216	23.45	23.86	Pass
60	5300	18.81	18.69	18.68	223.784	23.50	23.88	Pass
64	5320	17.61	17.75	17.58	174.523	22.42	23.95	Pass
100	5500	17.31	17.15	17.10	156.993	21.96	23.95	Pass
116	5580	18.68	18.54	18.59	217.517	23.37	23.95	Pass
140	5700	18.21	18.15	18.17	197.15	22.95	23.95	Pass
144	5720 (For U-NII-2C)	13.51	13.18	13.16	65.985	18.19	22.67	Pass
144	5720 (For U-NII-3)	6.88	7.03	7.28	15.757	11.97	30.00	Pass

Note:

For U-NII-2A, U-NII-2C Band:

Chain 0

1. $11\text{dBm} + 10\log(20.06) = 24.02 > 24\text{dBm}$
2. $11\text{dBm} + 10\log(20.06) = 24.02 > 24\text{dBm}$
3. $11\text{dBm} + 10\log(19.90) = 23.98 < 24\text{dBm}$
4. $11\text{dBm} + 10\log(20.06) = 24.02 > 24\text{dBm}$
5. $11\text{dBm} + 10\log(19.95) = 23.99 < 24\text{dBm}$
6. $11\text{dBm} + 10\log(20.06) = 24.02 > 24\text{dBm}$
7. $11\text{dBm} + 10\log(5725.00 - 5709.88) = 22.79 < 24\text{dBm}$

Chain 1

1. $11\text{dBm} + 10\log(19.33) = 23.86 < 24\text{dBm}$
2. $11\text{dBm} + 10\log(19.44) = 23.88 < 24\text{dBm}$
3. $11\text{dBm} + 10\log(19.73) = 23.95 < 24\text{dBm}$
4. $11\text{dBm} + 10\log(19.78) = 23.96 < 24\text{dBm}$
5. $11\text{dBm} + 10\log(19.76) = 23.95 < 24\text{dBm}$
6. $11\text{dBm} + 10\log(19.77) = 23.96 < 24\text{dBm}$
7. $11\text{dBm} + 10\log(5725.00 - 5709.89) = 22.79 < 24\text{dBm}$

Chain 2

1. $11\text{dBm} + 10\log(19.79) = 23.96 < 24\text{dBm}$
2. $11\text{dBm} + 10\log(20.10) = 24.03 > 24\text{dBm}$
3. $11\text{dBm} + 10\log(20.10) = 24.03 > 24\text{dBm}$
4. $11\text{dBm} + 10\log(19.76) = 23.95 < 24\text{dBm}$
5. $11\text{dBm} + 10\log(19.76) = 23.95 < 24\text{dBm}$
6. $11\text{dBm} + 10\log(19.74) = 23.95 < 24\text{dBm}$
7. $11\text{dBm} + 10\log(5725.00 - 5710.30) = 22.67 < 24\text{dBm}$

For reference only - power meter value

The power value was measured by power meter with average sensor

Chan.	Freq. (MHz)	Conducted Power (mW)	Conducted Power (dBm)
144	5720	215.278	23.33

802.11n (HT20)

Chan.	Freq. (MHz)	Average Power (dBm)			Total Power (mW)	Total Power (dBm)	Power Limit (dBm)	Pass / Fail
		Chain 0	Chain 1	Chain 2				
52	5260	18.72	18.66	18.70	222.055	23.46	24.00	Pass
60	5300	18.79	18.65	18.74	223.782	23.50	24.00	Pass
64	5320	18.17	18.05	17.99	192.392	22.84	24.00	Pass
100	5500	18.67	18.59	18.48	216.367	23.35	24.00	Pass
116	5580	18.63	18.60	18.52	216.511	23.35	24.00	Pass
140	5700	18.63	18.54	18.49	215.028	23.32	24.00	Pass
144	5720 (For U-NII-2C)	14.38	13.81	13.60	74.369	18.71	22.84	Pass
144	5720 (For U-NII-3)	8.28	8.02	8.34	19.892	12.99	30.00	Pass

Note:

For U-NII-2A, U-NII-2C Band:

Chain 0

1. $11\text{dBm} + 10\log(20.53) = 24.12 > 24\text{dBm}$
2. $11\text{dBm} + 10\log(20.51) = 24.11 > 24\text{dBm}$
3. $11\text{dBm} + 10\log(20.48) = 24.11 > 24\text{dBm}$
4. $11\text{dBm} + 10\log(20.62) = 24.14 > 24\text{dBm}$
5. $11\text{dBm} + 10\log(20.67) = 24.15 > 24\text{dBm}$
6. $11\text{dBm} + 10\log(20.67) = 24.15 > 24\text{dBm}$
7. $11\text{dBm} + 10\log(5725.00 - 5709.70) = 22.84 < 24\text{dBm}$

Chain 1

1. $11\text{dBm} + 10\log(20.68) = 24.15 > 24\text{dBm}$
2. $11\text{dBm} + 10\log(20.57) = 24.13 > 24\text{dBm}$
3. $11\text{dBm} + 10\log(20.56) = 24.13 > 24\text{dBm}$
4. $11\text{dBm} + 10\log(20.59) = 24.13 > 24\text{dBm}$
5. $11\text{dBm} + 10\log(20.65) = 24.14 > 24\text{dBm}$
6. $11\text{dBm} + 10\log(20.75) = 24.17 > 24\text{dBm}$
7. $11\text{dBm} + 10\log(5725.00 - 5709.66) = 22.85 < 24\text{dBm}$

Chain 2

1. $11\text{dBm} + 10\log(20.58) = 24.13 > 24\text{dBm}$
2. $11\text{dBm} + 10\log(20.64) = 24.14 > 24\text{dBm}$
3. $11\text{dBm} + 10\log(20.59) = 24.13 > 24\text{dBm}$
4. $11\text{dBm} + 10\log(20.63) = 24.14 > 24\text{dBm}$
5. $11\text{dBm} + 10\log(20.78) = 24.17 > 24\text{dBm}$
6. $11\text{dBm} + 10\log(20.76) = 24.17 > 24\text{dBm}$
7. $11\text{dBm} + 10\log(5725.00 - 5709.56) = 22.88 < 24\text{dBm}$

For reference only - power meter value

The power value was measured by power meter with average sensor

Chan.	Freq. (MHz)	Conducted Power (mW)	Conducted Power (dBm)
144	5720	213.796	23.30

802.11n (HT40)

Chan.	Freq. (MHz)	Average Power (dBm)			Total Power (mW)	Total Power (dBm)	Power Limit (dBm)	Pass / Fail
		Chain 0	Chain 1	Chain 2				
54	5270	18.70	18.62	18.66	220.360	23.43	24.00	Pass
62	5310	18.19	18.30	18.22	199.899	23.01	24.00	Pass
102	5510	18.28	18.17	18.13	197.926	22.97	24.00	Pass
110	5550	18.56	18.67	18.61	218.011	23.38	24.00	Pass
134	5670	18.52	18.65	18.61	217.014	23.36	24.00	Pass
142	5710 (For U-NII-2C)	16.48	17.25	16.64	148.008	21.70	24.00	Pass
142	5710 (For U-NII-3)	5.79	5.40	3.83	9.966	9.99	30.00	Pass

Note:

For U-NII-2A, U-NII-2C Band:

Chain 0

1. $11\text{dBm} + 10\log(41.08) = 27.13 > 24\text{dBm}$
2. $11\text{dBm} + 10\log(40.86) = 27.11 > 24\text{dBm}$
3. $11\text{dBm} + 10\log(40.84) = 27.11 > 24\text{dBm}$
4. $11\text{dBm} + 10\log(40.81) = 27.10 > 24\text{dBm}$
5. $11\text{dBm} + 10\log(40.90) = 27.11 > 24\text{dBm}$
6. $11\text{dBm} + 10\log(5725.00 - 5689.72) = 26.47 > 24\text{dBm}$

Chain 1

1. $11\text{dBm} + 10\log(40.85) = 27.11 > 24\text{dBm}$
2. $11\text{dBm} + 10\log(40.89) = 27.11 > 24\text{dBm}$
3. $11\text{dBm} + 10\log(40.90) = 27.11 > 24\text{dBm}$
4. $11\text{dBm} + 10\log(40.91) = 27.11 > 24\text{dBm}$
5. $11\text{dBm} + 10\log(40.98) = 27.12 > 24\text{dBm}$
6. $11\text{dBm} + 10\log(5725.00 - 5689.61) = 26.48 > 24\text{dBm}$

Chain 2

1. $11\text{dBm} + 10\log(40.53) = 27.07 > 24\text{dBm}$
2. $11\text{dBm} + 10\log(40.66) = 27.09 > 24\text{dBm}$
3. $11\text{dBm} + 10\log(40.68) = 27.09 > 24\text{dBm}$
4. $11\text{dBm} + 10\log(40.58) = 27.08 > 24\text{dBm}$
5. $11\text{dBm} + 10\log(40.62) = 27.08 > 24\text{dBm}$
6. $11\text{dBm} + 10\log(5725.00 - 5689.67) = 26.48 > 24\text{dBm}$

For reference only - power meter value

The power value was measured by power meter with average sensor

Chan.	Freq. (MHz)	Conducted Power (mW)	Conducted Power (dBm)
142	5710	215.774	23.34

802.11ac (VHT80)

Chan.	Freq. (MHz)	Average Power (dBm)			Total Power (mW)	Total Power (dBm)	Power Limit (dBm)	Pass / Fail
		Chain 0	Chain 1	Chain 2				
58	5290	16.10	16.06	16.27	123.467	20.92	24.00	Pass
106	5530	17.24	17.19	17.09	156.494	21.94	24.00	Pass
122	5610	17.73	17.60	17.55	173.722	22.40	24.00	Pass
138	5690 (For U-NII-2C)	13.44	15.59	15.57	100.141	20.01	24.00	Pass
138	5690 (For U-NII-3)	0.53	0.49	1.02	3.729	5.72	30.00	Pass

Note:

For U-NII-2A, U-NII-2C Band:

Chain 0

1. $11\text{dBm} + 10\log(83.98) = 30.24 > 24\text{dBm}$
2. $11\text{dBm} + 10\log(83.74) = 30.22 > 24\text{dBm}$
3. $11\text{dBm} + 10\log(82.77) = 30.17 > 24\text{dBm}$
4. $11\text{dBm} + 10\log(5725.00 - 5648.72) = 29.82 > 24\text{dBm}$

Chain 1

1. $11\text{dBm} + 10\log(84.05) = 30.24 > 24\text{dBm}$
2. $11\text{dBm} + 10\log(84.19) = 30.25 > 24\text{dBm}$
3. $11\text{dBm} + 10\log(84.22) = 30.25 > 24\text{dBm}$
4. $11\text{dBm} + 10\log(5725.00 - 5648.12) = 29.86 > 24\text{dBm}$

Chain 2

1. $11\text{dBm} + 10\log(84.13) = 30.24 > 24\text{dBm}$
2. $11\text{dBm} + 10\log(84.18) = 30.25 > 24\text{dBm}$
3. $11\text{dBm} + 10\log(84.18) = 30.25 > 24\text{dBm}$
4. $11\text{dBm} + 10\log(5725.00 - 5648.06) = 29.86 > 24\text{dBm}$

For reference only - power meter value

The power value was measured by power meter with average sensor

Chan.	Freq. (MHz)	Conducted Power (mW)	Conducted Power (dBm)
138	5690	211.349	23.25

Beamforming Mode

802.11n (HT20)

Chan.	Freq. (MHz)	Average Power (dBm)			Total Power (mW)	Total Power (dBm)	Power Limit (dBm)	Pass / Fail
		Chain 0	Chain 1	Chain 2				
52	5260	18.72	18.66	18.70	222.055	23.46	24.00	Pass
60	5300	18.79	18.65	18.74	223.782	23.50	24.00	Pass
64	5320	18.17	18.05	17.99	192.392	22.84	24.00	Pass
100	5500	18.67	18.59	18.48	216.367	23.35	24.00	Pass
116	5580	18.63	18.60	18.52	216.511	23.35	24.00	Pass
140	5700	18.63	18.54	18.49	215.028	23.32	24.00	Pass
144	5720 (For U-NII-2C)	14.38	13.81	13.60	74.369	18.71	22.84	Pass
144	5720 (For U-NII-3)	8.28	8.02	8.34	19.892	12.99	30.00	Pass

Note:

- 5260~5320MHz Directional gain = 4.15dBi < 6dBi, so the limit no need to be reduced.
- 5500~5720MHz Directional gain = 4.17dBi < 6dBi, so the limit no need to be reduced.
- 5745~5825MHz Directional gain = 4.80dBi < 6dBi, so the limit no need to be reduced.

For U-NII-2A, U-NII-2C Band:

Chain 0

- $11\text{dBm} + 10\log(20.53) = 24.12 > 24\text{dBm}$
- $11\text{dBm} + 10\log(20.51) = 24.11 > 24\text{dBm}$
- $11\text{dBm} + 10\log(20.48) = 24.11 > 24\text{dBm}$
- $11\text{dBm} + 10\log(20.62) = 24.14 > 24\text{dBm}$
- $11\text{dBm} + 10\log(20.67) = 24.15 > 24\text{dBm}$
- $11\text{dBm} + 10\log(20.67) = 24.15 > 24\text{dBm}$
- $11\text{dBm} + 10\log(5725.00 - 5709.70) = 22.84 < 24\text{dBm}$

Chain 1

- $11\text{dBm} + 10\log(20.68) = 24.15 > 24\text{dBm}$
- $11\text{dBm} + 10\log(20.57) = 24.13 > 24\text{dBm}$
- $11\text{dBm} + 10\log(20.56) = 24.13 > 24\text{dBm}$
- $11\text{dBm} + 10\log(20.59) = 24.13 > 24\text{dBm}$
- $11\text{dBm} + 10\log(20.65) = 24.14 > 24\text{dBm}$
- $11\text{dBm} + 10\log(20.75) = 24.17 > 24\text{dBm}$
- $11\text{dBm} + 10\log(5725.00 - 5709.66) = 22.85 < 24\text{dBm}$

Chain 2

- $11\text{dBm} + 10\log(20.58) = 24.13 > 24\text{dBm}$
- $11\text{dBm} + 10\log(20.64) = 24.14 > 24\text{dBm}$
- $11\text{dBm} + 10\log(20.59) = 24.13 > 24\text{dBm}$
- $11\text{dBm} + 10\log(20.63) = 24.14 > 24\text{dBm}$
- $11\text{dBm} + 10\log(20.78) = 24.17 > 24\text{dBm}$
- $11\text{dBm} + 10\log(20.76) = 24.17 > 24\text{dBm}$
- $11\text{dBm} + 10\log(5725.00 - 5709.56) = 22.88 < 24\text{dBm}$

For reference only - power meter value

The power value was measured by power meter with average sensor

Chan.	Freq. (MHz)	Conducted Power (mW)	Conducted Power (dBm)
144	5720	213.796	23.30

802.11n (HT40)

Chan.	Freq. (MHz)	Average Power (dBm)			Total Power (mW)	Total Power (dBm)	Power Limit (dBm)	Pass / Fail
		Chain 0	Chain 1	Chain 2				
54	5270	18.70	18.62	18.66	220.360	23.43	24.00	Pass
62	5310	18.19	18.30	18.22	199.899	23.01	24.00	Pass
102	5510	18.28	18.17	18.13	197.926	22.97	24.00	Pass
110	5550	18.56	18.67	18.61	218.011	23.38	24.00	Pass
134	5670	18.52	18.65	18.61	217.014	23.36	24.00	Pass
142	5710 (For U-NII-2C)	16.48	17.25	16.64	148.008	21.70	24.00	Pass
142	5710 (For U-NII-3)	5.79	5.40	3.83	9.966	9.99	30.00	Pass

Note:

- 5260~5320MHz Directional gain = 4.15dBi < 6dBi, so the limit no need to be reduced.
- 5500~5720MHz Directional gain = 4.17dBi < 6dBi, so the limit no need to be reduced.
- 5745~5825MHz Directional gain = 4.80dBi < 6dBi, so the limit no need to be reduced.

For U-NII-2A, U-NII-2C Band:

Chain 0

- 11dBm + 10log (41.08) = 27.13 > 24dBm
- 11dBm + 10log (40.86) = 27.11 > 24dBm
- 11dBm + 10log (40.84) = 27.11 > 24dBm
- 11dBm + 10log (40.81) = 27.10 > 24dBm
- 11dBm + 10log (40.90) = 27.11 > 24dBm
- 11dBm + 10log (5725.00 - 5689.72) = 26.47 > 24dBm

Chain 1

- 11dBm + 10log (40.85) = 27.11 > 24dBm
- 11dBm + 10log (40.89) = 27.11 > 24dBm
- 11dBm + 10log (40.90) = 27.11 > 24dBm
- 11dBm + 10log (40.91) = 27.11 > 24dBm
- 11dBm + 10log (40.98) = 27.12 > 24dBm
- 11dBm + 10log (5725.00 - 5689.61) = 26.48 > 24dBm

Chain 2

- 11dBm + 10log (40.53) = 27.07 > 24dBm
- 11dBm + 10log (40.66) = 27.09 > 24dBm
- 11dBm + 10log (40.68) = 27.09 > 24dBm
- 11dBm + 10log (40.58) = 27.08 > 24dBm
- 11dBm + 10log (40.62) = 27.08 > 24dBm
- 11dBm + 10log (5725.00 - 5689.67) = 26.48 > 24dBm

For reference only - power meter value

The power value was measured by power meter with average sensor

Chan.	Freq. (MHz)	Conducted Power (mW)	Conducted Power (dBm)
142	5710	215.774	23.34

802.11ac (VHT80)

Chan.	Freq. (MHz)	Average Power (dBm)			Total Power (mW)	Total Power (dBm)	Power Limit (dBm)	Pass / Fail
		Chain 0	Chain 1	Chain 2				
58	5290	16.10	16.06	16.27	123.467	20.92	24.00	Pass
106	5530	17.24	17.19	17.09	156.494	21.94	24.00	Pass
122	5610	17.73	17.60	17.55	173.722	22.40	24.00	Pass
138	5690 (For U-NII-2C)	13.44	15.59	15.57	100.141	20.01	24.00	Pass
138	5690 (For U-NII-3)	0.53	0.49	1.02	3.729	5.72	30.00	Pass

Note:

- 5260~5320MHz Directional gain = 4.15dBi < 6dBi, so the limit no need to be reduced.
- 5500~5720MHz Directional gain = 4.17dBi < 6dBi, so the limit no need to be reduced.
- 5745~5825MHz Directional gain = 4.80dBi < 6dBi, so the limit no need to be reduced.

For U-NII-2A, U-NII-2C Band:

Chain 0

- $11\text{dBm} + 10\log(83.98) = 30.24 > 24\text{dBm}$
- $11\text{dBm} + 10\log(83.74) = 30.22 > 24\text{dBm}$
- $11\text{dBm} + 10\log(82.77) = 30.17 > 24\text{dBm}$
- $11\text{dBm} + 10\log(5725.00 - 5648.72) = 29.82 > 24\text{dBm}$

Chain 1

- $11\text{dBm} + 10\log(84.05) = 30.24 > 24\text{dBm}$
- $11\text{dBm} + 10\log(84.19) = 30.25 > 24\text{dBm}$
- $11\text{dBm} + 10\log(84.22) = 30.25 > 24\text{dBm}$
- $11\text{dBm} + 10\log(5725.00 - 5648.12) = 29.86 > 24\text{dBm}$

Chain 2

- $11\text{dBm} + 10\log(84.13) = 30.24 > 24\text{dBm}$
- $11\text{dBm} + 10\log(84.18) = 30.25 > 24\text{dBm}$
- $11\text{dBm} + 10\log(84.18) = 30.25 > 24\text{dBm}$
- $11\text{dBm} + 10\log(5725.00 - 5648.06) = 29.86 > 24\text{dBm}$

For reference only - power meter value

The power value was measured by power meter with average sensor

Chan.	Freq. (MHz)	Conducted Power (mW)	Conducted Power (dBm)
138	5690	211.349	23.25

26dB Bandwidth:

802.11a

Chan.	Freq. (MHz)	26dBc Bandwidth (MHz)		
		Chain 0	Chain 1	Chain 2
52	5260	20.06	19.33	19.79
60	5300	20.06	19.44	20.10
64	5320	19.90	19.73	20.10
100	5500	20.06	19.78	19.76
116	5580	19.95	19.76	19.76
140	5700	20.06	19.77	19.74
144	5720 (For U-NII-2C)	15.12	15.11	14.70
144	5720 (For U-NII-3)	4.89	4.70	5.06

802.11n (HT20)

Chan.	Freq. (MHz)	26dBc Bandwidth (MHz)		
		Chain 0	Chain 1	Chain 2
52	5260	20.53	20.68	20.58
60	5300	20.51	20.57	20.64
64	5320	20.48	20.56	20.59
100	5500	20.62	20.59	20.63
116	5580	20.67	20.65	20.78
140	5700	20.67	20.75	20.76
144	5720 (For U-NII-2C)	15.30	15.34	15.44
144	5720 (For U-NII-3)	5.37	5.34	5.39

802.11n (HT40)

Chan.	Freq. (MHz)	26dBc Bandwidth (MHz)		
		Chain 0	Chain 1	Chain 2
54	5270	41.08	40.85	40.53
62	5310	40.86	40.89	40.66
102	5510	40.84	40.90	40.68
110	5550	40.81	40.91	40.58
134	5670	40.90	40.98	40.62
142	5710 (For U-NII-2C)	35.28	35.39	35.33
142	5710 (For U-NII-3)	5.45	5.49	5.26

802.11ac (VHT80)

Chan.	Freq. (MHz)	26dBc Bandwidth (MHz)		
		Chain 0	Chain 1	Chain 2
58	5290	83.98	84.05	84.13
106	5530	83.74	84.19	84.18
122	5610	82.77	84.22	84.18
138	5690 (For U-NII-2C)	76.28	76.88	76.94
138	5690 (For U-NII-3)	6.50	7.21	16.12

Spectrum Plot of Worst Value

802.11a

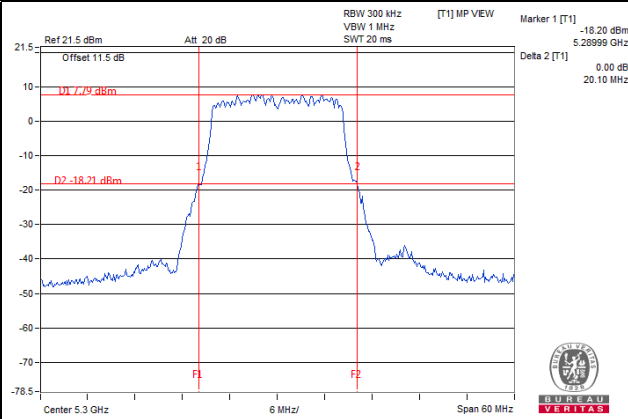

802.11n (HT20)

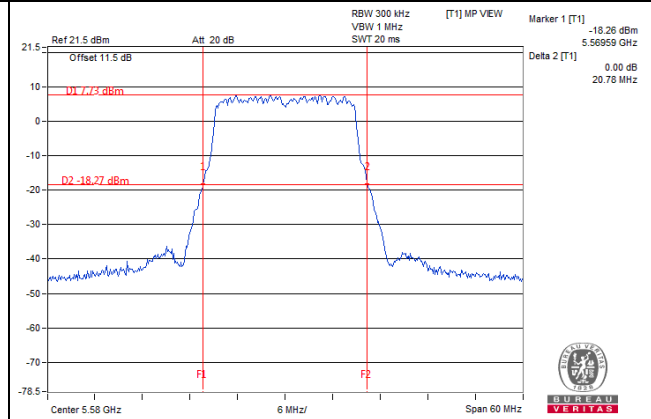

802.11n (HT40)

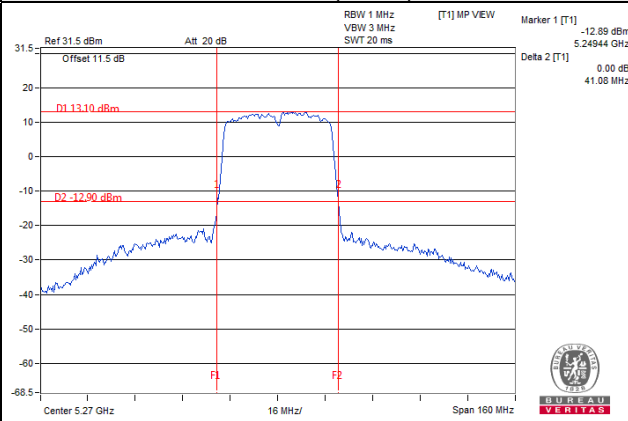

802.11ac (VHT80)

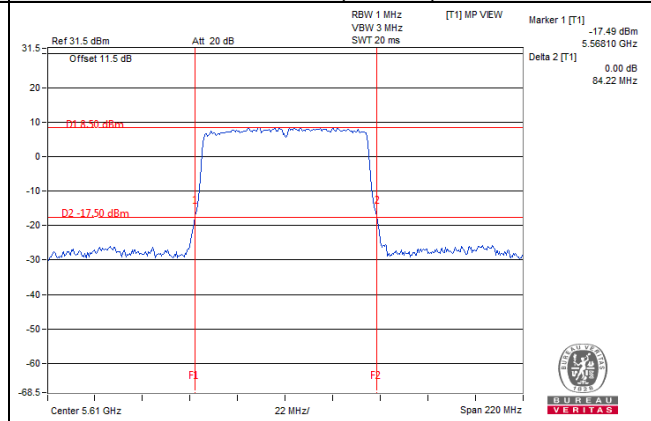

EUT Maximum Conducted Power

CDD Mode

802.11a

Frequency Band (MHz)	Max. Power	
	Output Power (mW)	Output Power (dBm)
5250~5350	223.784	23.50
5470~5725	217.517	23.37

802.11n (HT20)

Frequency Band (MHz)	Max. Power	
	Output Power (mW)	Output Power (dBm)
5250~5350	223.782	23.50
5470~5725	216.511	23.35

802.11n (HT40)

Frequency Band (MHz)	Max. Power	
	Output Power (mW)	Output Power (dBm)
5250~5350	220.360	23.43
5470~5725	218.011	23.38

802.11ac (VHT80)

Frequency Band (MHz)	Max. Power	
	Output Power (mW)	Output Power (dBm)
5250~5350	123.467	20.92
5470~5725	173.722	22.40

Beamforming Mode

802.11n (HT20)

Frequency Band (MHz)	Max. Power	
	Output Power (mW)	Output Power (dBm)
5250~5350	223.782	23.50
5470~5725	216.511	23.35

802.11n (HT40)

Frequency Band (MHz)	Max. Power	
	Output Power (mW)	Output Power (dBm)
5250~5350	220.360	23.43
5470~5725	218.011	23.38

802.11ac (VHT80)

Frequency Band (MHz)	Max. Power	
	Output Power (mW)	Output Power (dBm)
5250~5350	123.467	20.92
5470~5725	173.722	22.40

4.4 Occupied Bandwidth Measurement

4.4.1 Test Setup

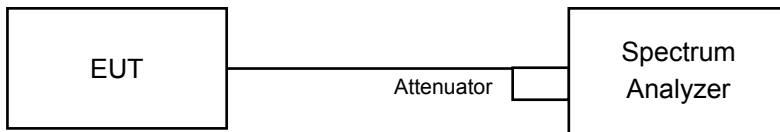

4.4.2 Test Instruments

Refer to section 4.1.2 to get information of above instrument.

4.4.3 Test Procedure

The transmitter output was connected to the spectrum analyzer through an attenuator. The bandwidth of the fundamental frequency was measured by spectrum analyzer with resolution bandwidth in the range of 1% to 5% of the anticipated emission bandwidth, and a video bandwidth at least 3x the resolution bandwidth and set the detector to sampling. The width of a frequency band such that, below the lower and above the upper frequency limits, the mean powers emitted are each equal to a specified percentage 0.5 %of the total mean power of a given emission.

4.4.4 Test Result

802.11a

Chan.	Freq. (MHz)	Occupied Bandwidth (MHz)		
		Chain 0	Chain 1	Chain 2
52	5260	16.56	16.44	16.44
60	5300	16.56	16.44	16.44
64	5320	16.44	16.44	16.44
100	5500	16.44	16.44	16.44
116	5580	16.44	16.44	16.44
140	5700	16.44	16.44	16.44
144	5720 (For U-NII-2C)	13.28	13.28	13.28
144	5720 (For U-NII-3)	3.16	3.16	3.16

802.11n (HT20)

Chan.	Freq. (MHz)	Occupied Bandwidth (MHz)		
		Chain 0	Chain 1	Chain 2
52	5260	17.64	17.64	17.64
60	5300	17.64	17.64	17.64
64	5320	17.64	17.64	17.64
100	5500	17.64	17.64	17.64
116	5580	17.64	17.64	17.64
140	5700	17.64	17.64	17.64
144	5720 (For U-NII-2C)	13.88	13.88	13.88
144	5720 (For U-NII-3)	3.76	3.76	3.76

802.11n (HT40)

Chan.	Freq. (MHz)	Occupied Bandwidth (MHz)		
		Chain 0	Chain 1	Chain 2
54	5270	36.00	36.00	36.00
62	5310	36.00	36.12	36.00
102	5510	36.00	36.12	36.00
110	5550	36.00	36.00	36.00
134	5670	36.00	36.00	36.00
142	5710 (For U-NII-2C)	33.00	33.00	33.00
142	5710 (For U-NII-3)	3.00	3.00	3.00

802.11ac (VHT80)

Chan.	Freq. (MHz)	Occupied Bandwidth (MHz)		
		Chain 0	Chain 1	Chain 2
58	5290	75.84	75.84	76.08
106	5530	75.84	76.08	76.08
122	5620	75.84	75.84	75.84
138	5690 (For U-NII-2C)	72.92	72.92	73.16
138	5690 (For U-NII-3)	2.92	2.92	2.92

Spectrum Plot of Worst Value

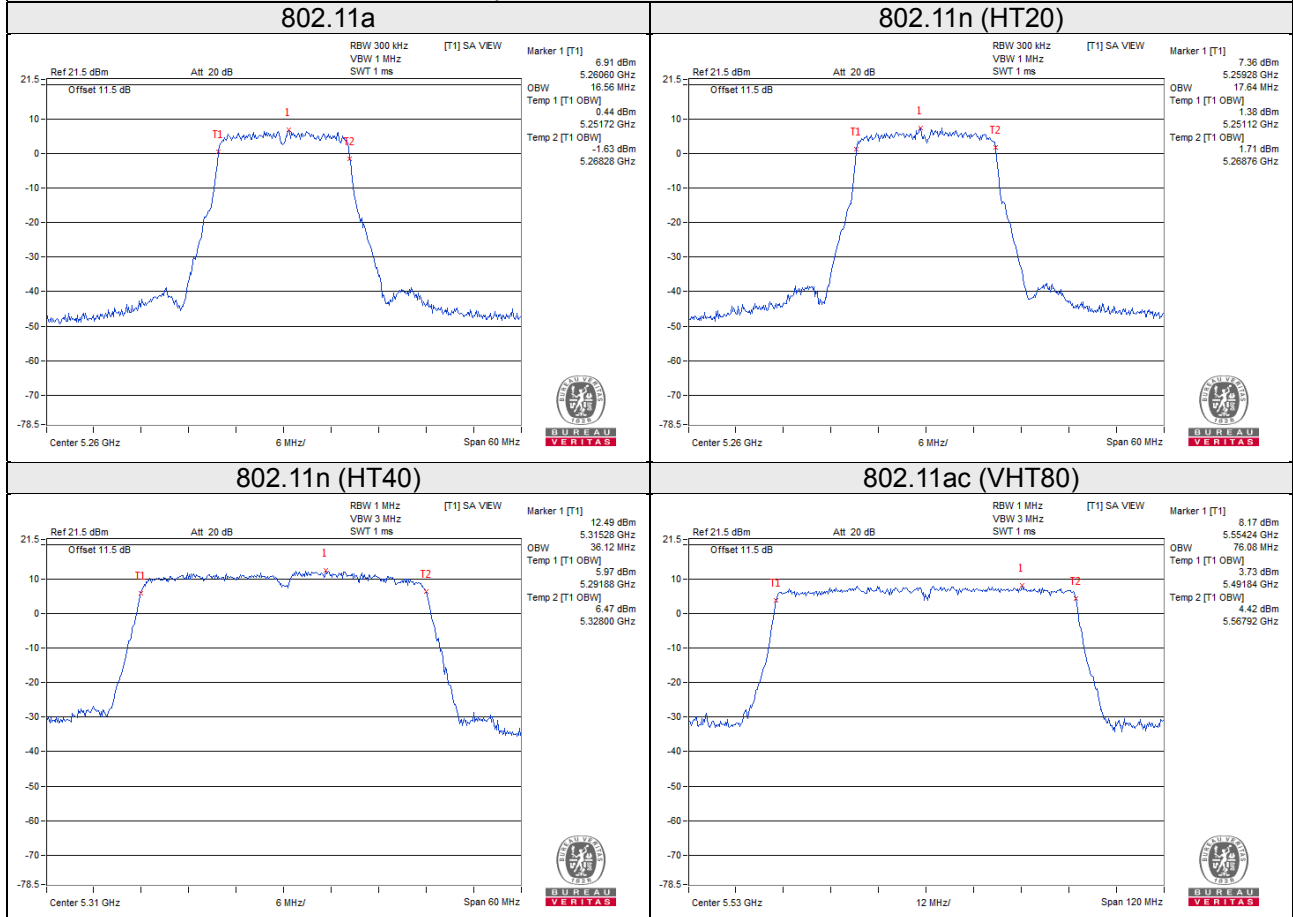

4.5 Peak Power Spectral Density Measurement

4.5.1 Limits of Peak Power Spectral Density Measurement

Operation Band	EUT Category		Limit
U-NII-1		Outdoor Access Point	17dBm/ MHz
		Fixed point-to-point Access Point	
		Indoor Access Point	
		Mobile and Portable client device	11dBm/ MHz
U-NII-2A	√		11dBm/ MHz
U-NII-2C	√		11dBm/ MHz
U-NII-3	√		30dBm/ 500kHz

4.5.2 Test Setup

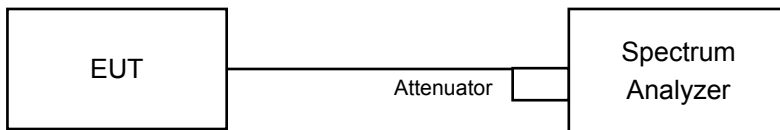

4.5.3 Test Instruments

Refer to section 4.1.2 to get information of above instrument.

4.5.4 Test Procedures

For U-NII-2A and U-NII-2C band:

Using method SA-2

- Set span to encompass the entire emission bandwidth (EBW) of the signal.
- Set RBW = 1MHz, Set VBW \geq 3 MHz, Detector = RMS
- Set Channel power measure = 1MHz
- Sweep time = auto, trigger set to "free run".
- Trace average at least 100 traces in power averaging mode.
- Record the max value and add 10 log (1/duty cycle)

For U-NII-3 band:

- Set span to encompass the entire emission bandwidth (EBW) of the signal.
- Set RBW = 300 kHz, Set VBW \geq 1 MHz, Detector = RMS
- Use the peak marker function to determine the maximum power level in any 300 kHz band segment within the fundamental EBW.
- Scale the observed power level to an equivalent value in 500 kHz by adjusting (reducing) the measured power by a bandwidth correction factor (BWCF) where $BWCF = 10\log(500 \text{ kHz} / 300 \text{ kHz})$
- Sweep time = auto, trigger set to "free run".
- Trace average at least 100 traces in power averaging mode.
- Record the max value and add 10 log (1/duty cycle)

4.5.5 Deviation from Test Standard

No deviation.

4.5.6 EUT Operating Conditions

Same as 4.3.6.

4.5.7 Test Results

For U-NII-2A and U-NII-2C band:

802.11a

Chan.	Freq. (MHz)	PSD w/o Duty Factor (dBm/MHz)			Duty Factor (dB)	Total PSD with Duty Factor (dBm/MHz)	Max. Limit (dBm/MHz)	Pass / Fail
		Chain 0	Chain 1	Chain 2				
52	5260	5.50	5.83	5.75	0.16	10.63	11.00	Pass
60	5300	5.60	5.93	5.92	0.16	10.75	11.00	Pass
64	5320	4.45	4.81	4.84	0.16	9.63	11.00	Pass
100	5500	3.96	4.36	3.57	0.16	8.91	11.00	Pass
116	5580	5.91	5.54	5.58	0.16	10.61	11.00	Pass
140	5700	5.23	5.35	5.11	0.16	10.16	11.00	Pass
144	5720	5.73	6.08	5.73	0.16	10.78	11.00	Pass

Note:

- Method 1 of power density measurement of KDB 662911 is using for calculating total power density. Total power density is summing entire spectra across corresponding frequency bins on the various outputs by computer.
- 5260~5320MHz: Directional gain = 4.15dBi < 6dBi, so the power density limit no need to reduced.
5500~5720MHz: Directional gain = 4.17dBi < 6dBi, so the power density limit no need to reduced.
- Refer to section 3.3 for duty cycle spectrum plot.

802.11n (HT20)

Chan.	Freq. (MHz)	PSD w/o Duty Factor (dBm/MHz)			Duty Factor (dB)	Total PSD with Duty Factor (dBm/MHz)	Max. Limit (dBm/MHz)	Pass / Fail
		Chain 0	Chain 1	Chain 2				
52	5260	4.98	5.07	5.38	0.15	10.07	11.00	Pass
60	5300	5.13	5.39	5.59	0.15	10.30	11.00	Pass
64	5320	4.51	4.85	4.95	0.15	9.70	11.00	Pass
100	5500	5.18	5.67	4.54	0.15	10.08	11.00	Pass
116	5580	5.00	5.26	4.64	0.15	9.90	11.00	Pass
140	5700	5.11	5.34	4.97	0.15	10.06	11.00	Pass
144	5720	5.12	5.48	5.04	0.15	10.14	11.00	Pass

Note:

- Method 1 of power density measurement of KDB 662911 is using for calculating total power density. Total power density is summing entire spectra across corresponding frequency bins on the various outputs by computer.
- 5260~5320MHz: Directional gain = 4.15dBi < 6dBi, so the power density limit no need to reduced.
5500~5720MHz: Directional gain = 4.17dBi < 6dBi, so the power density limit no need to reduced.
- Refer to section 3.3 for duty cycle spectrum plot.

802.11n (HT40)

Chan.	Freq. (MHz)	PSD w/o Duty Factor (dBm/MHz)			Duty Factor (dB)	Total PSD with Duty Factor (dBm/MHz)	Max. Limit (dBm/MHz)	Pass / Fail
		Chain 0	Chain 1	Chain 2				
54	5270	2.52	2.64	2.70	0.14	7.53	11.00	Pass
62	5310	2.09	2.21	2.27	0.14	7.10	11.00	Pass
102	5510	1.88	2.37	1.37	0.14	6.80	11.00	Pass
110	5550	2.57	2.29	2.50	0.14	7.37	11.00	Pass
134	5670	2.71	2.51	2.97	0.14	7.65	11.00	Pass
142	5710	2.64	2.82	2.77	0.14	7.66	11.00	Pass

Note:

- Method 1 of power density measurement of KDB 662911 is using for calculating total power density. Total power density is summing entire spectra across corresponding frequency bins on the various outputs by computer.
- 5260~5320MHz: Directional gain = 4.15dBi < 6dBi, so the power density limit no need to reduced.
5500~5720MHz: Directional gain = 4.17dBi < 6dBi, so the power density limit no need to reduced.
- Refer to section 3.3 for duty cycle spectrum plot.

802.11ac (VHT80)

Chan.	Freq. (MHz)	PSD w/o Duty Factor (dBm/MHz)			Duty Factor (dB)	Total PSD with Duty Factor (dBm/MHz)	Max. Limit (dBm/MHz)	Pass / Fail
		Chain 0	Chain 1	Chain 2				
58	5290	-3.53	-3.24	-3.21	0.27	1.72	11.00	Pass
106	5530	-2.20	-2.53	-2.48	0.27	2.64	11.00	Pass
122	5610	-1.27	-2.19	-2.04	0.27	3.23	11.00	Pass
138	5690	-0.29	-0.83	-1.06	0.27	4.33	11.00	Pass

Note:

- Method 1 of power density measurement of KDB 662911 is using for calculating total power density. Total power density is summing entire spectra across corresponding frequency bins on the various outputs by computer.
- 5260~5320MHz: Directional gain = 4.15dBi < 6dBi, so the power density limit no need to reduced.
5500~5720MHz: Directional gain = 4.17dBi < 6dBi, so the power density limit no need to reduced.
- Refer to section 3.3 for duty cycle spectrum plot.

Spectrum Plot of Worst Value

802.11a / Chain 1 / CH 144

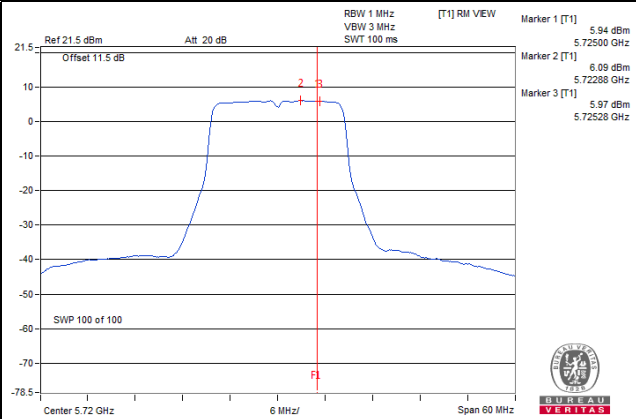

802.11n (HT20) / Chain 1 / CH 100

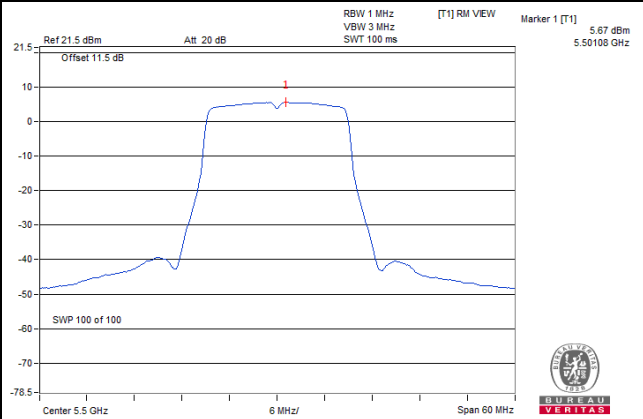

802.11n (HT40) / Chain 2 / CH 134

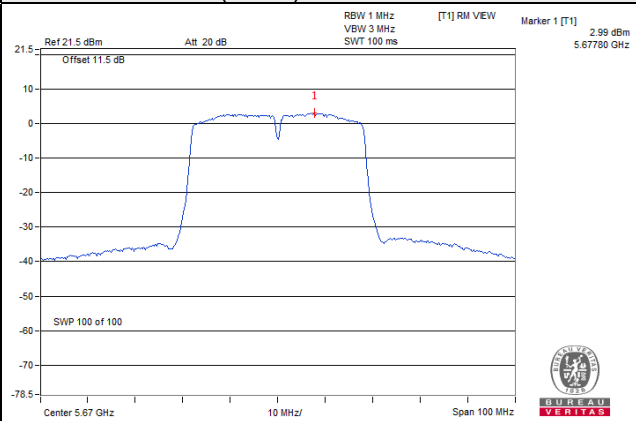

802.11ac (VHT80) / Chain 0 / 138

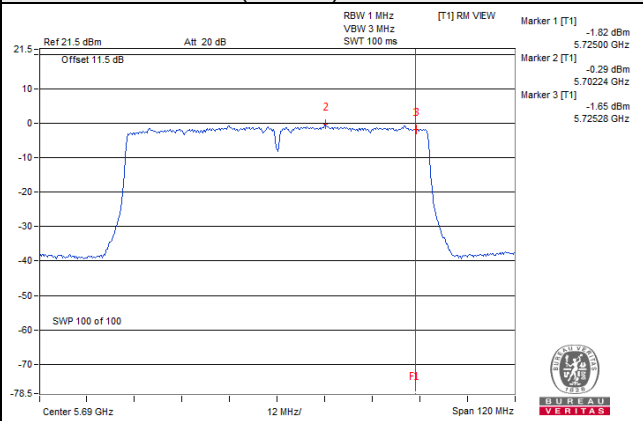

For U-NII-3 band:

802.11a

TX chain	Chan.	Freq. (MHz)	PSD w/o Duty Factor		10 log (N=3) dB	Duty Factor (dB)	Total PSD with Duty Factor (dBm/500kHz)	Limit (dBm/500 kHz)	Pass / Fail
			(dBm/300kHz)	(dBm/500kHz)					
0	144	5720	-2.48	-0.26	4.77	0.16	4.67	30.00	Pass
1	144	5720	-2.23	-0.01	4.77	0.16	4.92	30.00	Pass
2	144	5720	-2.58	-0.36	4.77	0.16	4.57	30.00	Pass

Note:

1. Directional gain = 4.80dBi < 6dBi, so the power density limit no need to reduced.
2. Refer to section 3.3 for duty cycle spectrum plot.

802.11n (HT20)

TX chain	Chan.	Freq. (MHz)	PSD w/o Duty Factor		10 log (N=3) dB	Duty Factor (dB)	Total PSD with Duty Factor (dBm/500kHz)	Limit (dBm/500 kHz)	Pass / Fail
			(dBm/300kHz)	(dBm/500kHz)					
0	144	5720	-3.39	-1.17	4.77	0.15	3.75	30.00	Pass
1	144	5720	-3.05	-0.83	4.77	0.15	4.09	30.00	Pass
2	144	5720	-3.11	-0.89	4.77	0.15	4.03	30.00	Pass

Note:

1. Directional gain = 4.80dBi < 6dBi, so the power density limit no need to reduced.
2. Refer to section 3.3 for duty cycle spectrum plot.

802.11n (HT40)

TX chain	Chan.	Freq. (MHz)	PSD w/o Duty Factor		10 log (N=3) dB	Duty Factor (dB)	Total PSD with Duty Factor (dBm/500kHz)	Limit (dBm/500 kHz)	Pass / Fail
			(dBm/300kHz)	(dBm/500kHz)					
0	142	5710	-7.33	-5.11	4.77	0.14	-0.20	30.00	Pass
1	142	5710	-7.02	-4.80	4.77	0.14	0.11	30.00	Pass
2	142	5710	-7.88	-5.66	4.77	0.14	-0.75	30.00	Pass

Note:

1. Directional gain = 4.80dBi < 6dBi, so the power density limit no need to reduced.
2. Refer to section 3.3 for duty cycle spectrum plot.

802.11ac (VHT80)

TX chain	Chan.	Freq. (MHz)	PSD w/o Duty Factor		10 log (N=3) dB	Duty Factor (dB)	Total PSD with Duty Factor (dBm/500kHz)	Limit (dBm/500 kHz)	Pass / Fail
			(dBm/300kHz)	(dBm/500kHz)					
0	138	5690	-10.49	-8.27	4.77	0.27	-3.23	30.00	Pass
1	138	5690	-10.35	-8.13	4.77	0.27	-3.09	30.00	Pass
2	138	5690	-10.98	-8.76	4.77	0.27	-3.72	30.00	Pass

Note:

1. Directional gain = 4.80dBi < 6dBi, so the power density limit no need to reduced.
2. Refer to section 3.3 for duty cycle spectrum plot.

Spectrum Plot of Worst Value

802.11a

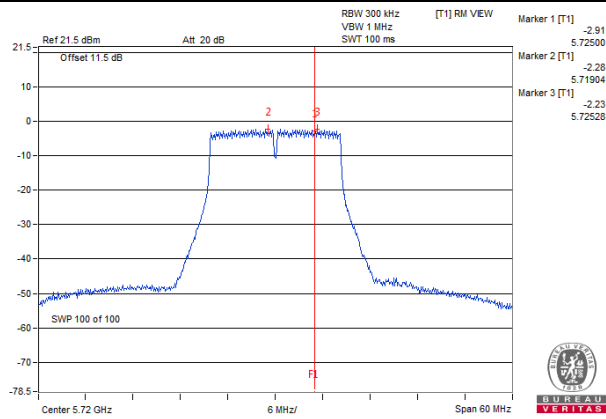

802.11n (HT20)

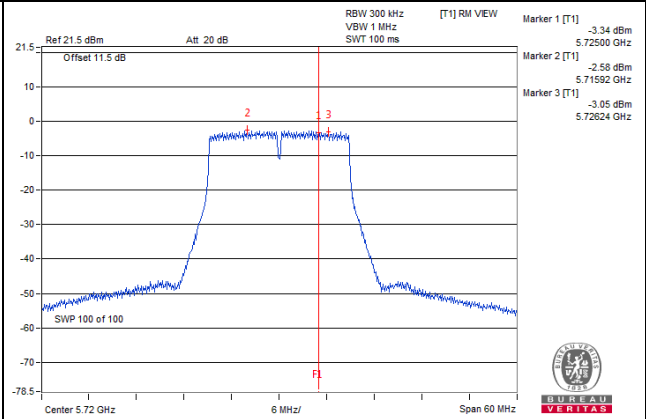

802.11n (HT40)

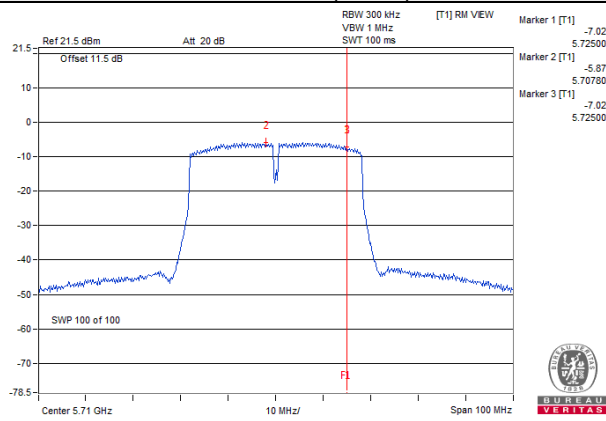

802.11ac (VHT80)

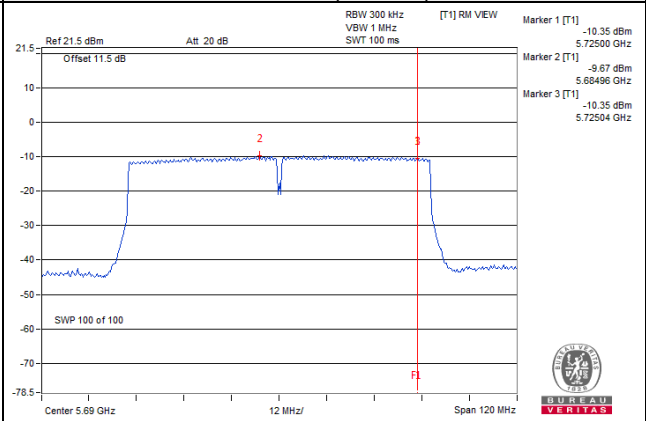

4.6 Frequency Stability

4.6.1 Limits of Frequency Stability Measurement

The frequency of the carrier signal shall be maintained within band of operation

4.6.2 Test Setup

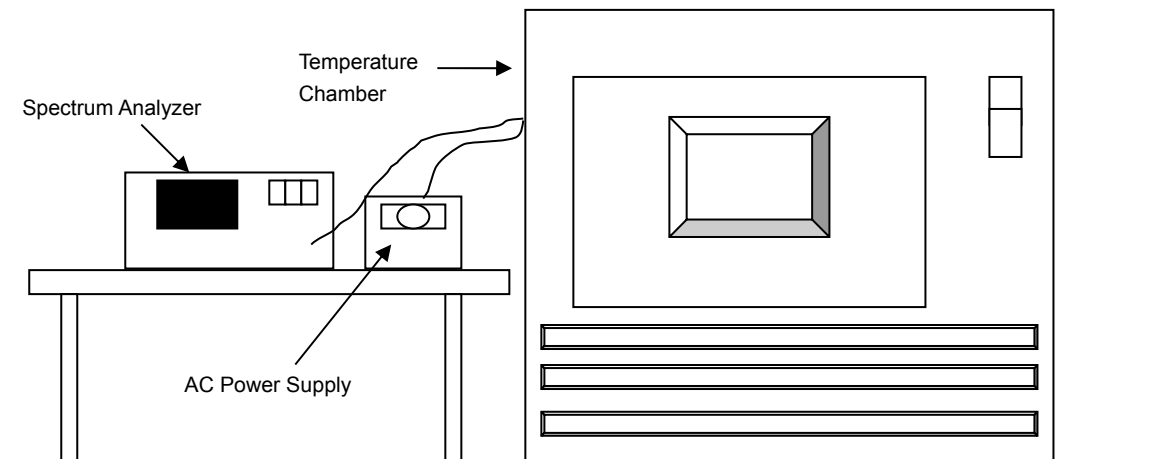

4.6.3 Test Instruments

Description & Manufacturer	Model No.	Serial No.	Cal. Date	Cal. Due
Spectrum Analyzer ROHDE & SCHWARZ	FSP40	100039	Jun. 11, 2018	Jun. 10, 2019
WIT Standard Temperature And Humidity Chamber	TH-4S-C	W981030	Jun. 04, 2018	Jun. 03, 2019
Digital Multimeter Fluke	87-III	70360742	Jun. 29, 2018	Jun. 28, 2019
AC Power Supply Extech	CFW-105	E000603	NA	NA

Note: 1. The calibration interval of the above test instruments is 12 months and the calibrations are traceable to NML/ROC and NIST/USA.

4.6.4 Test Procedure

- The EUT was placed inside the environmental test chamber and powered by nominal AC voltage.
- Turn the EUT on and couple its output to a spectrum analyzer.
- Turn the EUT off and set the chamber to the highest temperature specified.
- Allow sufficient time (approximately 30 min) for the temperature of the chamber to stabilize, turn the EUT on and measure the operating frequency after 2, 5, and 10 minutes.
- Repeat step 2 and 3 with the temperature chamber set to the lowest temperature.
- The test chamber was allowed to stabilize at +20 degree C for a minimum of 30 minutes. The supply voltage was then adjusted on the EUT from 85% to 115% and the frequency record.

4.6.5 Deviation from Test Standard

No deviation.

4.6.6 EUT Operating Condition

Set the EUT transmit at un-modulation mode to test frequency stability.

4.6.7 Test Results

Frequency Stability Versus Temp.									
Operating Frequency: 5260MHz									
Temp. (°C)	Power Supply (Vac)	0 Minute		2 Minute		5 Minute		10 Minute	
		Measured Frequency (MHz)	Result	Measured Frequency (MHz)	Result	Measured Frequency (MHz)	Result	Measured Frequency (MHz)	Result
45	120	5260.0194	Pass	5260.0195	Pass	5260.0213	Pass	5260.0182	Pass
40	120	5260.012	Pass	5260.0164	Pass	5260.0117	Pass	5260.0159	Pass
30	120	5259.994	Pass	5259.9891	Pass	5259.99	Pass	5259.9934	Pass
20	120	5260.0161	Pass	5260.0127	Pass	5260.0137	Pass	5260.014	Pass
10	120	5259.9788	Pass	5259.9806	Pass	5259.9803	Pass	5259.9802	Pass
0	120	5259.9775	Pass	5259.9822	Pass	5259.9787	Pass	5259.9783	Pass

Frequency Stability Versus Voltage									
Operating Frequency: 5260MHz									
Temp. (°C)	Power Supply (Vac)	0 Minute		2 Minute		5 Minute		10 Minute	
		Measured Frequency (MHz)	Result	Measured Frequency (MHz)	Result	Measured Frequency (MHz)	Result	Measured Frequency (MHz)	Result
20	138	5260.0167	Pass	5260.0123	Pass	5260.013	Pass	5260.0139	Pass
	120	5260.0161	Pass	5260.0127	Pass	5260.0137	Pass	5260.014	Pass
	102	5260.0152	Pass	5260.0124	Pass	5260.0134	Pass	5260.015	Pass

4.7 6dB Bandwidth Measurement

4.7.1 Limits of 6dB Bandwidth Measurement

The minimum of 6dB Bandwidth Measurement is 0.5MHz.

4.7.2 Test Setup

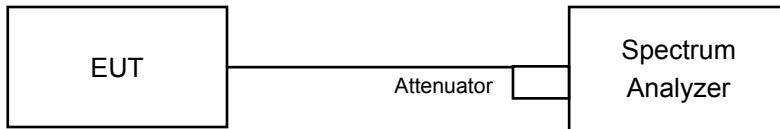

4.7.3 Test Instruments

Refer to section 4.1.2 to get information of above instrument.

4.7.4 Test Procedure

- Set resolution bandwidth (RBW) = 100kHz
- Set the video bandwidth (VBW) $\geq 3 \times$ RBW, Detector = Peak.
- Trace mode = max hold.
- Sweep = auto couple.
- Measure the maximum width of the emission that is constrained by the frequencies associated with the two amplitude points (upper and lower) that are attenuated by 6 dB relative to the maximum level measured in the fundamental emission

4.7.5 Deviation from Test Standard

No deviation.

4.7.6 EUT Operating Condition

The software provided by client to enable the EUT under transmission condition continuously at lowest, middle and highest channel frequencies individually.

4.7.7 Test Results

802.11a

Channel	Frequency (MHz)	6dB Bandwidth (MHz)			Minimum Limit (MHz)	Pass / Fail
		Chain 0	Chain 1	Chain 2		
144	5720 (For U-NII-3)	3.15	3.15	2.85	0.5	Pass

802.11n (HT20)

Channel	Frequency (MHz)	6dB Bandwidth (MHz)			Minimum Limit (MHz)	Pass / Fail
		Chain 0	Chain 1	Chain 2		
144	5720 (For U-NII-3)	3.47	3.75	3.75	0.5	Pass

802.11n (HT40)

Channel	Frequency (MHz)	6dB Bandwidth (MHz)			Minimum Limit (MHz)	Pass / Fail
		Chain 0	Chain 1	Chain 2		
142	5710 (For U-NII-2C)	2.54	2.62	2.56	0.5	Pass

802.11ac (VHT80)

Channel	Frequency (MHz)	6dB Bandwidth (MHz)			Minimum Limit (MHz)	Pass / Fail
		Chain 0	Chain 1	Chain 2		
138	5690 (For U-NII-2C)	3.10	3.03	2.77	0.5	Pass

Spectrum Plot of Worst Value

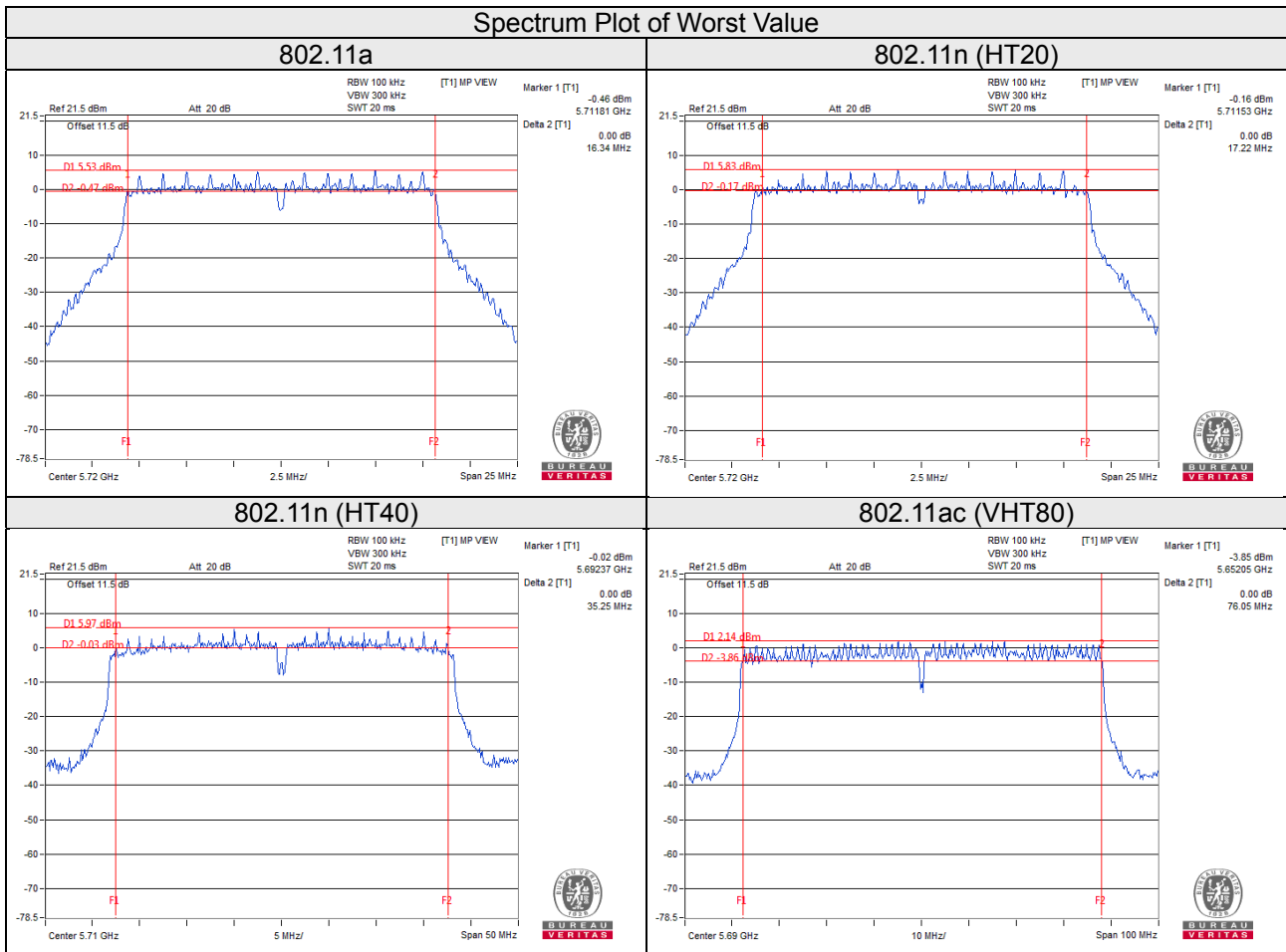

Note:

For CH144 (UNII-3 Band): The 6dB bandwidth above 5725MHz = Marker 1 + Delta 2 - 5725MHz

For CH142 (UNII-3 Band): The 6dB bandwidth above 5725MHz = Marker 1 + Delta 2 - 5725MHz

For CH138 (UNII-3 Band): The 6dB bandwidth above 5725MHz = Marker 1 + Delta 2 - 5725MHz

5 Pictures of Test Arrangements

Please refer to the attached file (Test Setup Photo).

Appendix – Information on the Testing Laboratories

We, Bureau Veritas Consumer Products Services (H.K.) Ltd., Taoyuan Branch, were founded in 1988 to provide our best service in EMC, Radio, Telecom and Safety consultation. Our laboratories are FCC recognized accredited test firms and accredited and approved according to ISO/IEC 17025.

If you have any comments, please feel free to contact us at the following:

Linko EMC/RF Lab

Tel: 886-2-26052180

Fax: 886-2-26051924

Hsin Chu EMC/RF/Telecom Lab

Tel: 886-3-6668565

Fax: 886-3-6668323

Hwa Ya EMC/RF/Safety

Tel: 886-3-3183232

Fax: 886-3-3270892

Email: service.adt@tw.bureauveritas.com

Web Site: www.bureauveritas-adt.com

The address and road map of all our labs can be found in our web site also.

--- END ---