

## FCC Test Report (DFS Band)

**Report No.:** RF160913E02A-1

**FCC ID:** PY316200342

**Test Model:** R6400v2

**Received Date:** Nov. 02, 2016

**Test Date:** Nov. 10 to 16, 2016

**Issued Date:** Mar. 29, 2017

**Applicant:** NETGEAR, Inc.

**Address:** 350 East Plumeria Drive San Jose, CA 95134

**Issued By:** Bureau Veritas Consumer Products Services (H.K.) Ltd., Taoyuan Branch  
Hsin Chu Laboratory

**Lab Address:** E-2, No.1, Li Hsin 1st Road, Hsinchu Science Park, Hsinchu City 300,  
Taiwan R.O.C.

**Test Location (1):** E-2, No.1, Li Hsin 1st Road, Hsinchu Science Park, Hsinchu City 300,  
Taiwan R.O.C.

**Test Location (2):** No. 49, Ln. 206, Wende Rd., Shangshan Tsuen, Chiung Lin Hsiang, Hsin  
Chu Hsien 307, Taiwan R.O.C.



This report is for your exclusive use. Any copying or replication of this report to or for any other person or entity, or use of our name or trademark, is permitted only with our prior written permission. This report sets forth our findings solely with respect to the test samples identified herein. The results set forth in this report are not indicative or representative of the quality or characteristics of the lot from which a test sample was taken or any similar or identical product unless specifically and expressly noted. Our report includes all of the tests requested by you and the results thereof based upon the information that you provided to us. You have 60 days from date of issuance of this report to notify us of any material error or omission caused by our negligence, provided, however, that such notice shall be in writing and shall specifically address the issue you wish to raise. A failure to raise such issue within the prescribed time shall constitute your unqualified acceptance of the completeness of this report, the tests conducted and the correctness of the report contents. Unless specific mention, the uncertainty of measurement has been explicitly taken into account to declare the compliance or non-compliance to the specification. The report must not be used by the client to claim product certification, approval, or endorsement by TAF or any government agencies.

## Table of Contents

<b>Release Control Record</b> .....	<b>4</b>
<b>1 Certificate of Conformity</b> .....	<b>5</b>
<b>2 Summary of Test Results</b> .....	<b>6</b>
2.1 Measurement Uncertainty .....	6
2.2 Modification Record .....	6
<b>3 General Information</b> .....	<b>7</b>
3.1 General Description of EUT .....	7
3.2 Description of Test Modes .....	10
3.2.1 Test Mode Applicability and Tested Channel Detail .....	11
3.3 Duty Cycle of Test Signal .....	13
3.4 Description of Support Units .....	14
3.4.1 Configuration of System under Test .....	15
3.5 General Description of Applied Standard .....	16
<b>4 Test Types and Results</b> .....	<b>17</b>
4.1 Radiated Emission and Bandedge Measurement .....	17
4.1.1 Limits of Radiated Emission and Bandedge Measurement .....	17
4.1.2 Test Instruments .....	18
4.1.3 Test Procedure .....	20
4.1.4 Deviation from Test Standard .....	20
4.1.5 Test Setup .....	21
4.1.6 EUT Operating Condition .....	22
4.1.7 Test Results (Mode 2) .....	23
4.2 Conducted Emission Measurement .....	44
4.2.1 Limits of Conducted Emission Measurement .....	44
4.2.2 Test Instruments .....	44
4.2.3 Test Procedure .....	45
4.2.4 Deviation from Test Standard .....	45
4.2.5 Test Setup .....	45
4.2.6 EUT Operating Condition .....	45
4.2.7 Test Results (Mode 1) .....	46
4.2.8 Test Results (Mode 2) .....	48
4.3 Transmit Power Measurement .....	50
4.3.1 Limits of Transmit Power Measurement .....	50
4.3.2 Test Setup .....	50
4.3.3 Test Instruments .....	50
4.3.4 Test Procedure .....	51
4.3.5 Deviation from Test Standard .....	51
4.3.6 EUT Operating Condition .....	51
4.3.7 Test Result .....	52
4.4 Occupied Bandwidth Measurement .....	57
4.4.1 Test Setup .....	57
4.4.2 Test Instruments .....	57
4.4.3 Test Procedure .....	57
4.4.4 Test Results .....	58
4.5 Peak Power Spectral Density Measurement .....	60
4.5.1 Limits of Peak Power Spectral Density Measurement .....	60
4.5.2 Test Setup .....	60
4.5.3 Test Instruments .....	60
4.5.4 Test Procedure .....	60
4.5.5 Deviation from Test Standard .....	60
4.5.6 EUT Operating Condition .....	60
4.5.7 Test Results .....	61
4.6 Frequency Stability Measurement .....	64

4.6.1	Limits of Frequency Stability Measurement .....	64
4.6.2	Test Setup.....	64
4.6.3	Test Instruments .....	64
4.6.4	Test Procedure .....	64
4.6.5	Deviation from Test Standard .....	64
4.6.6	EUT Operating Condition .....	64
4.6.7	Test Results .....	65
<b>5</b>	<b>Pictures of Test Arrangements.....</b>	<b>66</b>
	<b>Appendix – Information on the Testing Laboratories .....</b>	<b>67</b>

### Release Control Record

Issue No.	Description	Date Issued
RF160913E02A-1	Original release.	Mar. 29, 2017

## 1 Certificate of Conformity

**Product:** AC1750 Smart WiFi Router

**Brand:** NETGEAR

**Test Model:** R6400v2

**Sample Status:** ENGINEERING SAMPLE

**Applicant:** NETGEAR, Inc.

**Test Date:** Nov. 10 to 16, 2016

**Standard:** 47 CFR FCC Part 15, Subpart E (Section 15.407)  
ANSI C63.10: 2013

The above equipment has been tested by **Bureau Veritas Consumer Products Services (H.K.) Ltd., Taoyuan Branch**, and found compliance with the requirement of the above standards. The test record, data evaluation & Equipment Under Test (EUT) configurations represented herein are true and accurate accounts of the measurements of the sample's EMC characteristics under the conditions specified in this report.

**Prepared by :** Wendy Wu , **Date:** Mar. 29, 2017  
Wendy Wu / Specialist

**Approved by :** May Chen , **Date:** Mar. 29, 2017  
May Chen / Manager

## 2 Summary of Test Results

47 CFR FCC Part 15, Subpart E (Section 15.407)			
FCC Clause	Test Item	Result	Remarks
15.407(b)(6)	AC Power Conducted Emissions	Pass	Meet the requirement of limit. Minimum passing margin is -12.65dB at 0.29849MHz.
15.407(b) (1/2/3/4(i/ii)/6)	Radiated Emissions & Band Edge Measurement*	Pass	Meet the requirement of limit. Minimum passing margin is -0.2dB at 5470.00MHz.
15.407(a)(1/2/3)	Max Average Transmit Power	Pass	Meet the requirement of limit.
---	Occupied Bandwidth Measurement	-	Reference only.
15.407(a)(1/2/3)	Peak Power Spectral Density	Pass	Meet the requirement of limit.
15.407(e)	6dB bandwidth	Pass	Meet the requirement of limit. (U-NII-3 Band only)
15.407(g)	Frequency Stability	Pass	Meet the requirement of limit.
15.203	Antenna Requirement	Pass	Antenna connector is i-pex (MHF) not a standard connector.

### 2.1 Measurement Uncertainty

Where relevant, the following measurement uncertainty levels have been estimated for tests performed on the EUT as specified in CISPR 16-4-2:

Measurement	Frequency	Expanded Uncertainty (k=2) (±)
Conducted Emissions at mains ports	150kHz ~ 30MHz	1.83 dB
Radiated Emissions up to 1 GHz	30MHz ~ 1GHz	5.19 dB
Radiated Emissions above 1 GHz	1GHz ~ 6GHz	3.43 dB
	6GHz ~ 18GHz	3.49 dB
	18GHz ~ 40GHz	4.11 dB

### 2.2 Modification Record

There were no modifications required for compliance.

### 3 General Information

#### 3.1 General Description of EUT (DFS Band)

Product	AC1750 Smart WiFi Router
Brand	NETGEAR
Test Model	R6400v2
Status of EUT	ENGINEERING SAMPLE
Power Supply Rating	12Vdc from power adapter
Modulation Type	64QAM, 16QAM, QPSK, BPSK for OFDM 256QAM for OFDM in 11ac mode and VHT20/40 mode in 2.4GHz band
Modulation Technology	OFDM
Transfer Rate	802.11a: up to 54Mbps 802.11n: up to 450Mbps 802.11ac: up to 1300Mbps
Operating Frequency	5.26 ~ 5.32GHz, 5.50 ~ 5.70GHz
Number of Channel	802.11a, 802.11n (HT20), 802.11ac (VHT20): 15 802.11n (HT40), 802.11ac (VHT40): 7 802.11ac (VHT80): 3
Output Power	<b>5.26GHz ~ 5.32GHz:</b> <b>CDD Mode:</b> 233.329mW <b>Beamforming Mode:</b> 235.09mW <b>5.50GHz ~ 5.70GHz:</b> <b>CDD Mode:</b> 237.081mW <b>Beamforming Mode:</b> 245.947mW
Antenna Type	Refer to Note
Antenna Connector	Refer to Note
Accessory Device	Adapter x 1
Data Cable Supplied	NA

Note:

- This report is prepared for FCC class II permissive change. The difference compared with the Report No.: RF160913E02-1 as the following:
  - ◆ Add DFS band <5.26GHz ~ 5.32GHz, 5.50GHz ~ 5.70GHz>
- According to above condition, all test items need to be performed. And all data weres verified to meet the requirements.
- Simultaneously transmission condition.

Condition	Technology	
1	WLAN (2.4GHz)	WLAN (5GHz)

**Note:** The emission of the simultaneous operation has been evaluated and no non-compliance was found.

4. The EUT must be supplied with a power adapter and following different models could be chosen as following table:

No	Brand Name	Model No.	P/N	Spec.
1	NETGEAR	2ABL030F 1 NA	332-10758-01	Input: 100-120Vac, 50/60Hz, 1.0A Output: 12Vdc, 2.5A DC output cable (Unshielded, 1.8m)
2	NETGEAR	AD2067F10	332-10797-01	Input: 100-120Vac, 50/60Hz, 1.0A Output: 12Vdc, 2.5A DC output cable (Unshielded, 1.8m)

Note: From the above adapters, the radiated emission worse case was found in Adapter 2. Therefore only the test data of the mode was recorded in this report.

5. The antennas provided to the EUT, please refer to the following table:

Antenna No.	Brand	Model	Antenna Gain(dBi)	Frequency range (GHz ~ GHz)	Antenna Type	Connecter Type
98612PIPF003	NA	NA	3.4	2.4~2.4835	Dipole	I-pex (MHF)
			3.94	5.15~5.25		
			3.44	5.25~5.35		
			3.44	5.47~5.725		
			3.73	5.725~5.85		
98612PIPF004	NA	NA	3.23	2.4~2.4835	Dipole	I-pex (MHF)
			3.66	5.15~5.25		
			3.83	5.25~5.35		
			3.83	5.47~5.725		
			3.77	5.725~5.85		
98612PIPF005	NA	NA	3.36	2.4~2.4835	Dipole	I-pex (MHF)
			3.32	5.15~5.25		
			3.63	5.25~5.35		
			3.63	5.47~5.725		
			3.74	5.725~5.85		

6. The Directional gain table:

Frequency (MHz)	Max Gain (dBi)
5260-5320	5.95
5500-5700	5.98

Note:

1. Non-TxBF mode & TxBF mode antenna gain refer to KDB 662911 F 2) f) (ii)

$$DirectionalGain = 10 \cdot \log \left[ \frac{\sum_{j=1}^{N_{SS}} \left\{ \sum_{k=1}^{N_{ANT}} g_{j,k} \right\}^2}{N_{ANT}} \right]$$

where

Each antenna is driven by no more than one spatial stream;

$N_{SS}$  = the number of independent spatial streams of data;

$N_{ANT}$  = the total number of antennas

$g_{j,k} = 10^{G_k / 20}$  if the  $k$ th antenna is being fed by spatial stream  $j$ , or zero if it is not;  
 $G_k$  is the gain in dBi of the  $k$ th antenna.



7. The EUT incorporates a MIMO function.

2.4GHz Band			
MODULATION MODE	DATA RATE (MCS)	TX & RX CONFIGURATION	
802.11b	1 ~ 11Mbps	3TX	3RX
802.11g	6 ~ 54Mbps	3TX	3RX
802.11n (HT20)	MCS 0~7	3TX	3RX
	MCS 8~15	3TX	3RX
	MCS16~23	3TX	3RX
802.11n (HT40)	MCS 0~7	3TX	3RX
	MCS 8~15	3TX	3RX
	MCS16~23	3TX	3RX
5GHz Band			
MODULATION MODE	DATA RATE (MCS)	TX & RX CONFIGURATION	
802.11a	6 ~ 54Mbps	3TX	3RX
802.11n (HT20)	MCS 0~7	3TX	3RX
	MCS 8~15	3TX	3RX
	MCS16~23	3TX	3RX
802.11n (HT40)	MCS 0~7	3TX	3RX
	MCS 8~15	3TX	3RX
	MCS16~23	3TX	3RX
802.11ac (VHT20)	MCS0~8 Nss=1	3TX	3RX
	MCS0~8 Nss=2	3TX	3RX
	MCS0~9 Nss=3	3TX	3RX
802.11ac (VHT40)	MCS0~9 Nss=1	3TX	3RX
	MCS0~9 Nss=2	3TX	3RX
	MCS0~9 Nss=3	3TX	3RX
802.11ac (VHT80)	MCS0~9 Nss=1	3TX	3RX
	MCS0~9 Nss=2	3TX	3RX
	MCS0~9 Nss=3	3TX	3RX

Note:

1. All of modulation mode support beamforming function except 802.11a modulation mode and 2.4GHz band.
2. The modulation and bandwidth are similar for 802.11n mode for 20MHz (40MHz) and 802.11ac mode for 20MHz (40MHz), therefore investigated worst case to representative mode in test report. (Final test mode refer section 3.2.1)

8. The above EUT information is declared by manufacturer and for more detailed features description, please refer to the manufacturer's specifications or user's manual.

### 3.2 Description of Test Modes

#### FOR 5260 ~ 5320MHz

4 channels are provided for 802.11a, 802.11n (HT20), 802.11ac (VHT20):

Channel	Frequency	Channel	Frequency
52	5260 MHz	60	5300 MHz
56	5280 MHz	64	5320 MHz

2 channels are provided for 802.11n (HT40), 802.11ac (VHT40):

Channel	Frequency	Channel	Frequency
54	5270 MHz	62	5310 MHz

1 channel is provided for 802.11ac (VHT80):

Channel	Frequency
58	5290MHz

#### FOR 5500 ~ 5700MHz

11 channels are provided for 802.11a, 802.11n (HT20), 802.11ac (VHT20):

Channel	Frequency	Channel	Frequency
100	5500 MHz	124	5620 MHz
104	5520 MHz	128	5640 MHz
108	5540 MHz	132	5660 MHz
112	5560 MHz	136	5680 MHz
116	5580 MHz	140	5700 MHz
120	5600 MHz		

5 channels are provided for 802.11n (HT40), 802.11ac (VHT40):

Channel	Frequency	Channel	Frequency
102	5510 MHz	126	5630 MHz
110	5550 MHz	134	5670 MHz
118	5590 MHz		

2 channels are provided for 802.11ac (VHT80):

Channel	Frequency	Channel	Frequency
106	5530MHz	122	5610 MHz

### 3.2.1 Test Mode Applicability and Tested Channel Detail

EUT Configure Mode	Applicable To				Description
	RE $\geq$ 1G	RE<1G	PLC	APCM	
1	-	-	√	-	With adapter 1
2	√	√	√	√	With adapter 2

Where **RE $\geq$ 1G**: Radiated Emission above 1GHz      **RE<1G**: Radiated Emission below 1GHz  
**PLC**: Power Line Conducted Emission      **APCM**: Antenna Port Conducted Measurement

**NOTE:**

1. The EUT had been pre-tested on the positioned of each 2 axis. The worst case was found when positioned on **X-plane**.
2. "-" means no effect.

#### **Radiated Emission Test (Above 1GHz):**

- Pre-Scan has been conducted to determine the worst-case mode from all possible combinations between available modulations, data rates and antenna ports (if EUT with antenna diversity architecture).
- Following channel(s) was (were) selected for the final test as listed below.

CDD Mode						
Mode	FREQ. Band (MHz)	Available Channel	Tested Channel	Modulation Technology	Modulation Type	Data Rate (Mbps)
802.11a	5260-5320	52 to 64	52, 60, 64	OFDM	BPSK	6
802.11a	5500-5700	100 to 140	100, 116, 140	OFDM	BPSK	6
Beamforming Mode						
Mode	FREQ. Band (MHz)	Available Channel	Tested Channel	Modulation Technology	Modulation Type	Data Rate (Mbps)
802.11ac (VHT20)	5260-5320	52 to 64	52, 60, 64	OFDM	BPSK	6.5
802.11ac (VHT40)		54 to 62	54, 62	OFDM	BPSK	13.5
802.11ac (VHT80)		58	58	OFDM	BPSK	29.3
802.11ac (VHT20)	5500-5700	100 to 140	100, 116, 140	OFDM	BPSK	6.5
802.11ac (VHT40)		102 to 134	102, 110, 134	OFDM	BPSK	13.5
802.11ac (VHT80)		106 to 122	106, 122	OFDM	BPSK	29.3

#### **Radiated Emission Test (Below 1GHz):**

- Pre-Scan has been conducted to determine the worst-case mode from all possible combinations between available modulations, data rates and antenna ports (if EUT with antenna diversity architecture).
- Following channel(s) was (were) selected for the final test as listed below.

Beamforming Mode						
Mode	FREQ. Band (MHz)	Available Channel	Tested Channel	Modulation Technology	Modulation Type	Data Rate (Mbps)
802.11ac (VHT40)	5500-5700	102 to 134	110	OFDM	BPSK	13.5

### Power Line Conducted Emission Test:

- Pre-Scan has been conducted to determine the worst-case mode from all possible combinations between available modulations, data rates and antenna ports (if EUT with antenna diversity architecture).
- Following channel(s) was (were) selected for the final test as listed below.

Beamforming Mode						
Mode	FREQ. Band (MHz)	Available Channel	Tested Channel	Modulation Technology	Modulation Type	Data Rate (Mbps)
802.11ac (VHT40)	5500-5700	102 to 134	110	OFDM	BPSK	13.5

### Antenna Port Conducted Measurement:

- This item includes all test value of each mode, but only includes spectrum plot of worst value of each mode.
- Pre-Scan has been conducted to determine the worst-case mode from all possible combinations between available modulations, data rates and antenna ports (if EUT with antenna diversity architecture).
- Following channel(s) was (were) selected for the final test as listed below.

CDD Mode						
Mode	FREQ. Band (MHz)	Available Channel	Tested Channel	Modulation Technology	Modulation Type	Data Rate (Mbps)
802.11a	5260-5320	52 to 64	52, 60, 64	OFDM	BPSK	6
802.11a	5500-5700	100 to 140	100, 116, 140	OFDM	BPSK	6
Beamforming Mode						
Mode	FREQ. Band (MHz)	Available Channel	Tested Channel	Modulation Technology	Modulation Type	Data Rate (Mbps)
802.11ac (VHT20)	5260-5320	52 to 64	52, 60, 64	OFDM	BPSK	6.5
802.11ac (VHT40)		54 to 62	54, 62	OFDM	BPSK	13.5
802.11ac (VHT80)		58	58	OFDM	BPSK	29.3
802.11ac (VHT20)	5500-5700	100 to 140	100, 116, 140	OFDM	BPSK	6.5
802.11ac (VHT40)		102 to 134	102, 110, 134	OFDM	BPSK	13.5
802.11ac (VHT80)		106 to 122	106, 122	OFDM	BPSK	29.3

### Test Condition:

Applicable To	Environmental Conditions	Input Power	Tested By
RE $\geq$ 1G	23deg. C, 68%RH	120Vac, 60Hz	Weiwei Lo
RE $<$ 1G	22deg. C, 65%RH	120Vac, 60Hz	Robert Cheng
PLC	26deg. C, 60%RH	120Vac, 60Hz	Barry Lee
APCM	24deg. C, 62%RH	120Vac, 60Hz	Jyunchen Lin

### 3.3 Duty Cycle of Test Signal

If duty cycle of test signal is  $\geq 98\%$ , duty factor is not required.

If duty cycle of test signal is  $< 98\%$ , duty factor shall be considered.

**802.11a:** Duty cycle =  $2.062 \text{ ms} / 2.084 \text{ ms} = 0.989$

**802.11ac (VHT20):** Duty cycle =  $1.926 \text{ ms} / 1.947 \text{ ms} = 0.989$

**802.11ac (VHT40):** Duty cycle =  $0.955 \text{ ms} / 0.973 \text{ ms} = 0.982$

**802.11ac (VHT80):** Duty cycle =  $0.459 \text{ ms} / 0.48 \text{ ms} = 0.956$ , Duty factor =  $10 * \log(1/0.956) = 0.19$

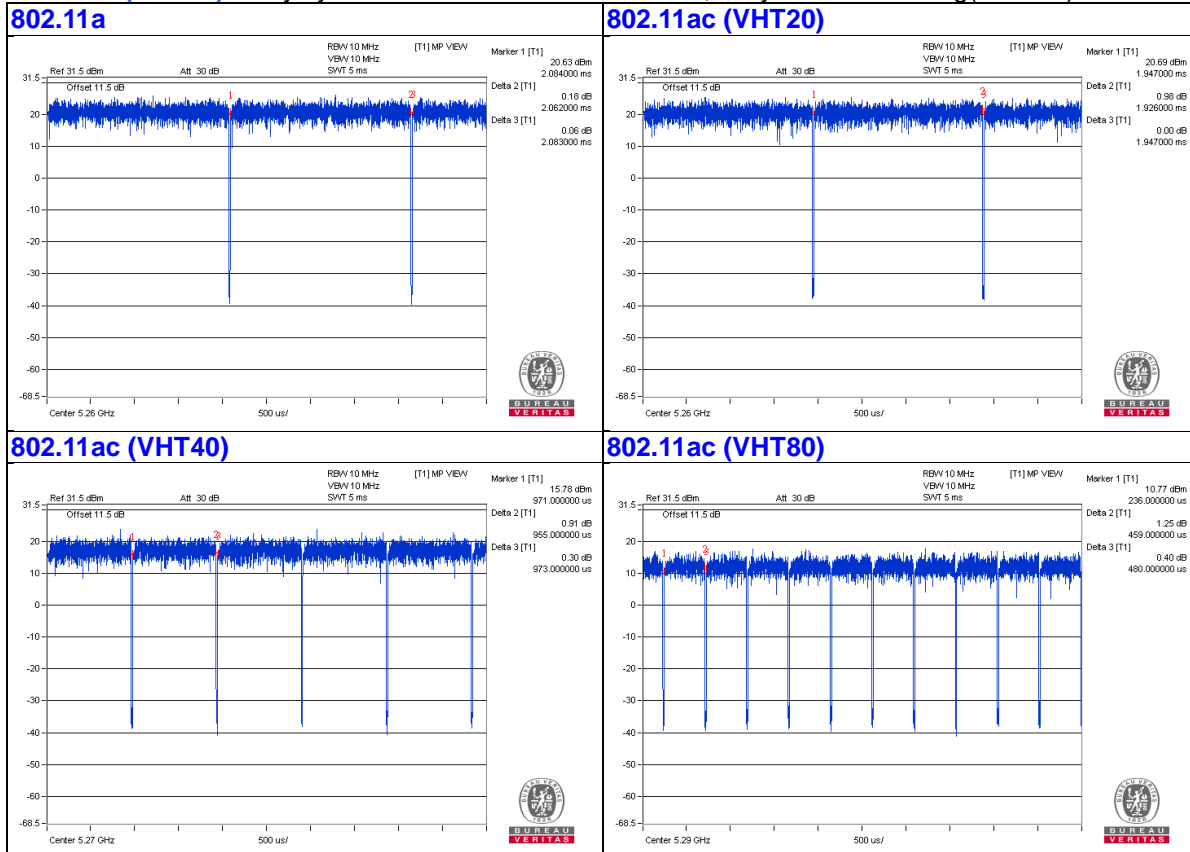

### 3.4 Description of Support Units

The EUT has been tested as an independent unit together with other necessary accessories or support units. The following support units or accessories were used to form a representative test configuration during the tests.

ID	Product	Brand	Model No.	Serial No.	FCC ID	Remarks
A.	Laptop	DELL	E5430	4YV4VY1	FCC DoC	Provided by Lab
B.	Laptop	DELL	E5430	HYV4VY1	FCC DoC	Provided by Lab
C.	HUB	ZyXEL	ES-116P	S060H02000215	FCC DoC	Provided by Lab
D.	iPod	Apple	MC749TA/A	CC4DN25WDFDM	NA	Provided by Lab
E.	USB Disk	Transcend(16GB)	NA	NA	NA	Provided by Lab

Note:

1. All power cords of the above support units are non-shielded (1.8m).

ID	Descriptions	Qty.	Length (m)	Shielding (Yes/No)	Cores (Qty.)	Remarks
1.	RJ-45 Cable	1	10	No	0	Provided by Lab
2.	RJ-45 Cable	1	10	No	0	Provided by Lab
3.	RJ-45 Cable	3	10	No	0	Provided by Lab
4.	DC Cable	1	1.8	No	0	Supplied by client
5.	USB Cable	1	0.1	No	0	Provided by Lab

Note: The core(s) is(are) originally attached to the cable(s).

### 3.4.1 Configuration of System under Test

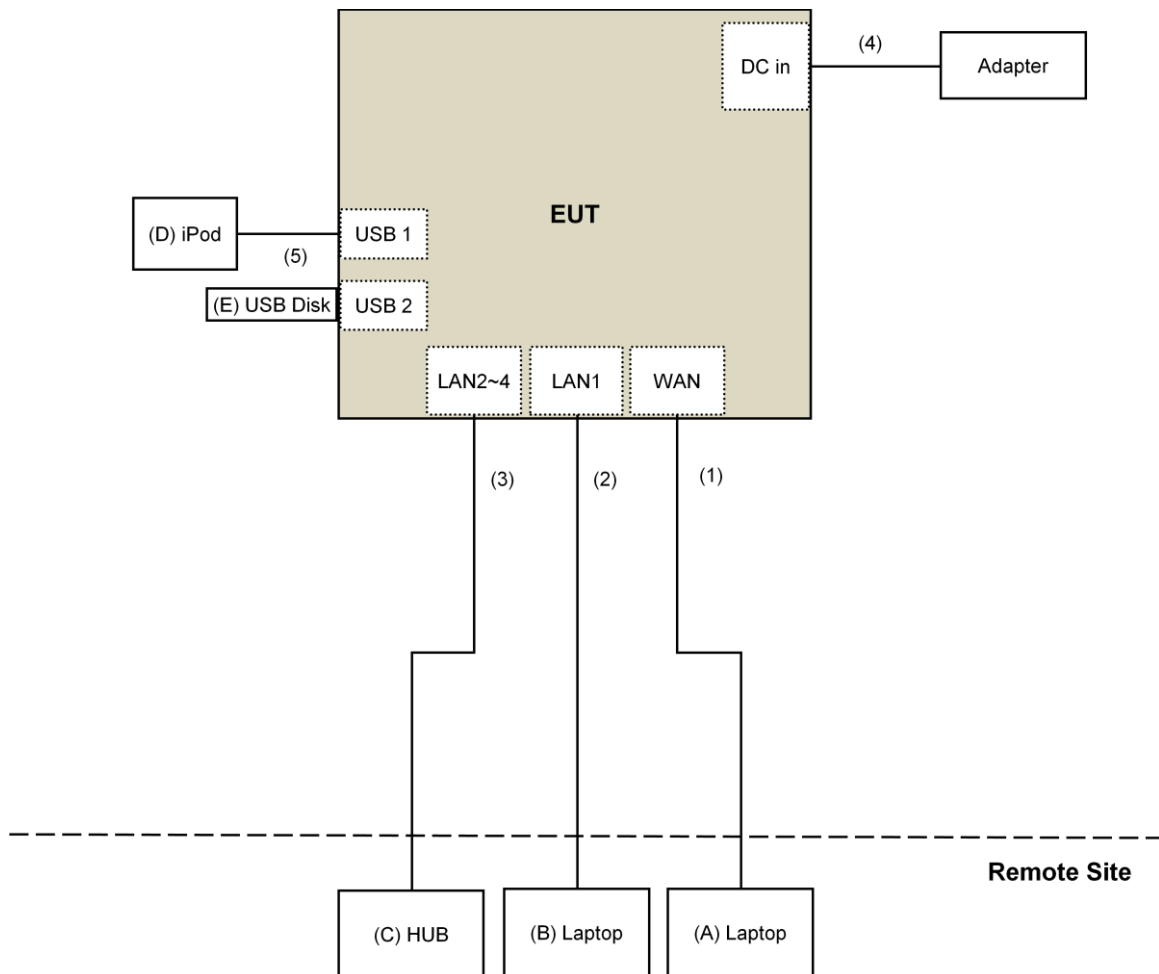

### 3.5 General Description of Applied Standard

The EUT is a RF Product. According to the specifications of the manufacturer, it must comply with the requirements of the following standards:

**FCC Part 15, Subpart E (15.407)**  
**KDB 789033 D02 General UNII Test Procedure New Rules v01r03**  
**KDB 662911 D01 Multiple Transmitter Output v02r01**  
**ANSI C63.10-2013**

All test items have been performed and recorded as per the above standards.

**NOTE:** The EUT has been verified to comply with the requirements of FCC Part 15, Subpart B, Class B (DoC). The test report has been issued separately.



## 4 Test Types and Results

### 4.1 Radiated Emission and Bandedge Measurement

#### 4.1.1 Limits of Radiated Emission and Bandedge Measurement

Radiated emissions which fall in the restricted bands must comply with the radiated emission limits specified as below table.

Frequencies (MHz)	Field Strength (microvolts/meter)	Measurement Distance (meters)
0.009 ~ 0.490	2400/F(kHz)	300
0.490 ~ 1.705	24000/F(kHz)	30
1.705 ~ 30.0	30	30
30 ~ 88	100	3
88 ~ 216	150	3
216 ~ 960	200	3
Above 960	500	3

#### NOTE:

1. The lower limit shall apply at the transition frequencies.
2. Emission level (dBuV/m) = 20 log Emission level (uV/m).
3. For frequencies above 1000MHz, the field strength limits are based on average detector, however, the peak field strength of any emission shall not exceed the maximum permitted average limits, specified above by more than 20dB under any condition of modulation.

Limits of unwanted emission out of the restricted bands

Applicable To		Limit	
789033 D02 General UNII Test Procedure New Rules v01r03		Field Strength at 3m	
		PK:74 (dBuV/m)	AV:54 (dBuV/m)
Frequency Band	Applicable To	EIRP Limit	Equivalent Field Strength at 3m
5150~5250 MHz	15.407(b)(1)	PK:-27 (dBm/MHz)	PK:68.2(dBuV/m)
5250~5350 MHz	15.407(b)(2)		
5470~5725 MHz	15.407(b)(3)		
5725~5850 MHz	<input type="checkbox"/> 15.407(b)(4)(i)	PK:-27 (dBm/MHz) <sup>*1</sup> PK:10 (dBm/MHz) <sup>*2</sup> PK:15.6 (dBm/MHz) <sup>*3</sup> PK:27 (dBm/MHz) <sup>*4</sup>	PK: 68.2(dBuV/m) <sup>*1</sup> PK:105.2 (dBuV/m) <sup>*2</sup> PK: 110.8(dBuV/m) <sup>*3</sup> PK:122.2 (dBuV/m) <sup>*4</sup>
	<input type="checkbox"/> 15.407(b)(4)(ii)	Emission limits in section 15.247(d)	
<sup>*1</sup> beyond 75 MHz or more above of the band edge.		<sup>*2</sup> below the band edge increasing linearly to 10 dBm/MHz at 25 MHz above.	
<sup>*3</sup> below the band edge increasing linearly to a level of 15.6 dBm/MHz at 5 MHz above.		<sup>*4</sup> from 5 MHz above or below the band edge increasing linearly to a level of 27 dBm/MHz at the band edge.	

#### Note:

The following formula is used to convert the equipment isotropic radiated power (eirp) to field strength:

$$E = \frac{1000000\sqrt{30P}}{3} \mu\text{V/m, where } P \text{ is the eirp (Watts).}$$

## 4.1.2 Test Instruments

DESCRIPTION & MANUFACTURER	MODEL NO.	SERIAL NO.	CALIBRATED DATE	CALIBRATED UNTIL
Test Receiver Keysight	N9038A	MY54450088	July 20, 2016	July 19, 2017
Pre-Amplifier <sup>(*)</sup> EMCI	EMC001340	980142	Jan. 20, 2016	Jan. 19, 2018
Loop Antenna <sup>(*)</sup> Electro-Metrics	EM-6879	264	Dec. 16, 2014	Dec. 15, 2016
RF Cable	NA	LOOPCAB-001 LOOPCAB-002	Jan. 18, 2016	Jan. 17, 2017
Pre-Amplifier Mini-Circuits	ZFL-1000VH2B	AMP-ZFL-01	Nov. 10, 2016	Nov. 09, 2017
Trilog Broadband Antenna SCHWARZBECK	VULB 9168	9168-406	Jan. 04, 2016	Jan. 03, 2017
RF Cable	8D	966-4-1 966-4-2 966-4-3	Apr. 02, 2016	Apr. 01, 2017
Fixed attenuator Mini-Circuits	UNAT-5+	PAD-3m-4-01	Oct. 05, 2016	Oct. 04, 2017
Horn_Antenna SCHWARZBECK	BBHA 9120D	9120D-783	Jan. 19, 2016	Jan. 18, 2017
Pre-Amplifier Agilent	8449B	3008A01922	Sep. 18, 2016	Sep. 17, 2017
RF Cable	EMC104-SM-SM-2000 EMC104-SM-SM-5000 EMC104-SM-SM-5000	150318 150323 150324	Mar. 30, 2016	Mar. 29, 2017
Pre-Amplifier EMCI	EMC184045	980143	Jan. 15, 2016	Jan. 14, 2017
Horn_Antenna SCHWARZBECK	BBHA 9170	BBHA9170608	Jan. 08, 2016	Jan. 07, 2017
RF Cable	SUCOFLEX 102	36432/2 36441/2	Jan. 16, 2016	Jan. 15, 2017
Software	ADT_Radiated_V8.7.08	NA	NA	NA
Antenna Tower & Turn Table Max-Full	MF-7802	MF780208410	NA	NA
Boresight Antenna Fixture	FBA-01	FBA-SIP02	NA	NA
Spectrum Analyzer R&S	FSv40	100964	June 28, 2016	June 27, 2017
Power meter Anritsu	ML2495A	1014008	May 5, 2016	May 4, 2017
Power sensor Anritsu	MA2411B	0917122	May 5, 2016	May 4, 2017
AC Power Source Extech Electronics	6205	1440452	NA	NA
Temperature & Humidity Chamber Giant Force	GTH-150-40-SP-AR	MAA0812-008	Jan. 15, 2016	Jan. 14, 2017
Digital Multimeter FLUKE	87III	73680266	Nov. 10, 2016	Nov. 09, 2017

**Note:**

1. The calibration interval of the above test instruments is 12 months and the calibrations are traceable to NML/ROC and NIST/USA.
2. \*The calibration interval of the above test instruments is 24 months and the calibrations are traceable to NML/ROC and NIST/USA.
3. The test was performed in 966 Chamber No. 4.
4. The FCC Site Registration No. is 292998
5. The CANADA Site Registration No. is 20331-2
- 6 Loop antenna was used for all emissions below 30 MHz.
7. Tested Date: Nov. 10 to 16, 2016

#### 4.1.3 Test Procedure

##### **For Radiated emission below 30MHz**

- a. The EUT was placed on the top of a rotating table 0.8 meters above the ground at a 3 meter chamber room. The table was rotated 360 degrees to determine the position of the highest radiation.
- b. The EUT was set 3 meters away from the interference-receiving antenna, which was mounted on the top of a variable-height antenna tower.
- c. Both X and Y axes of the antenna are set to make the measurement.
- d. For each suspected emission, the EUT was arranged to its worst case and the rotatable table was turned from 0 degrees to 360 degrees to find the maximum reading.
- e. The test-receiver system was set to Quasi-Peak Detect Function and Specified Bandwidth with Maximum Hold Mode.

##### **NOTE:**

1. The resolution bandwidth and video bandwidth of test receiver/spectrum analyzer is 9kHz at frequency below 30MHz.

##### **For Radiated emission above 30MHz**

- a. The EUT was placed on the top of a rotating table 0.8 meters (for 30MHz ~ 1GHz) / 1.5 meters (for above 1GHz) above the ground at 3 meter chamber room for test. The table was rotated 360 degrees to determine the position of the highest radiation.
- b. The EUT was set 3 meters away from the interference-receiving antenna, which was mounted on the top of a variable-height antenna tower.
- c. The height of antenna is varied from one meter to four meters above the ground to determine the maximum value of the field strength. Both horizontal and vertical polarizations of the antenna are set to make the measurement.
- d. For each suspected emission, the EUT was arranged to its worst case and then the antenna was tuned to heights from 1 meter to 4 meters and the rotatable table was turned from 0 degrees to 360 degrees to find the maximum reading.
- e. The test-receiver system was set to quasi-peak detect function and specified bandwidth with maximum hold mode when the test frequency is below 1 GHz.
- f. The test-receiver system was set to peak and average detect function and specified bandwidth with maximum hold mode when the test frequency is above 1 GHz. If the peak reading value also meets average limit, measurement with the average detector is unnecessary.

##### **Note:**

1. The resolution bandwidth and video bandwidth of test receiver/spectrum analyzer is 120kHz for Quasi-peak detection (QP) at frequency below 1GHz.
2. The resolution bandwidth of test receiver/spectrum analyzer is 1 MHz and the video bandwidth is 3 MHz for Peak detection (PK) at frequency above 1GHz.
3. The resolution bandwidth of test receiver/spectrum analyzer is 1MHz and the video bandwidth is  $\geq 1/T$  (Duty cycle < 98%) or 10Hz (Duty cycle  $\geq 98\%$ ) for Average detection (AV) at frequency above 1GHz.
4. All modes of operation were investigated and the worst-case emissions are reported.

#### 4.1.4 Deviation from Test Standard

No deviation.

#### 4.1.5 Test Setup

##### For Radiated emission below 30MHz

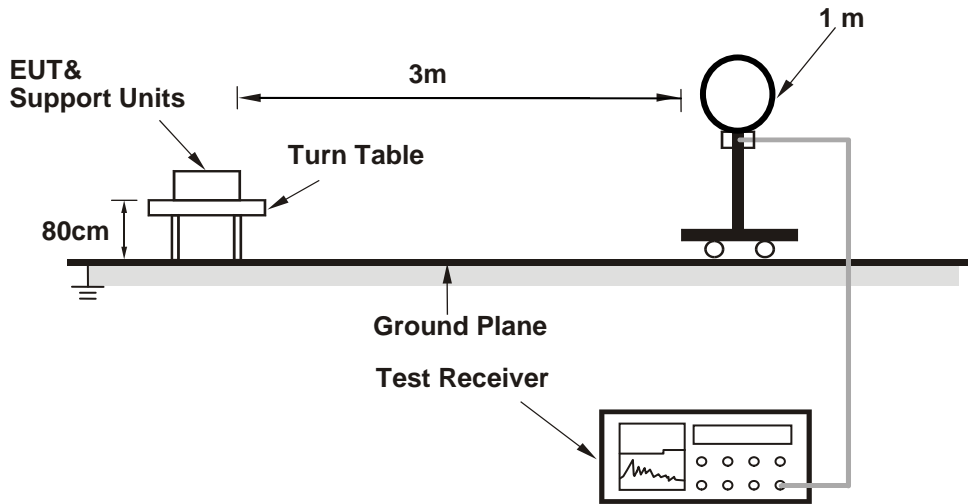

##### For Radiated emission 30MHz to 1GHz

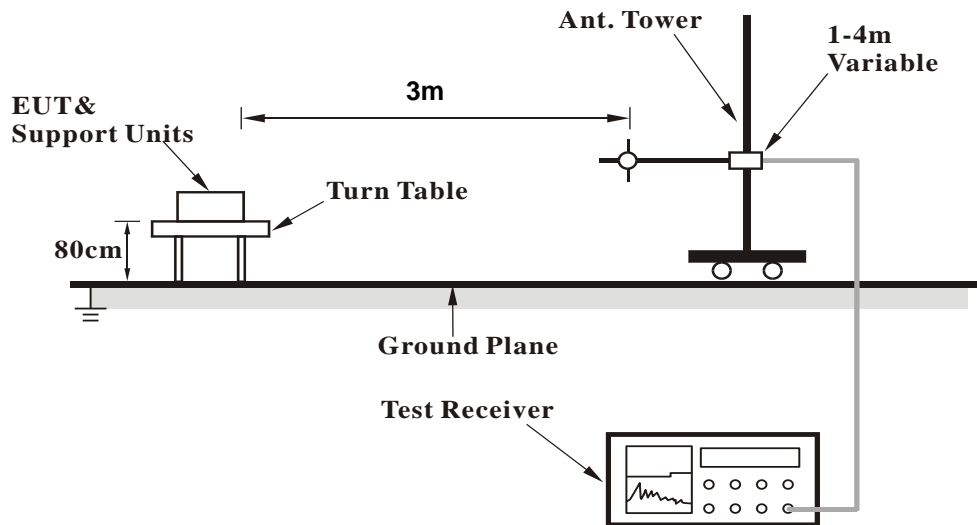

**For Radiated emission above 1GHz**

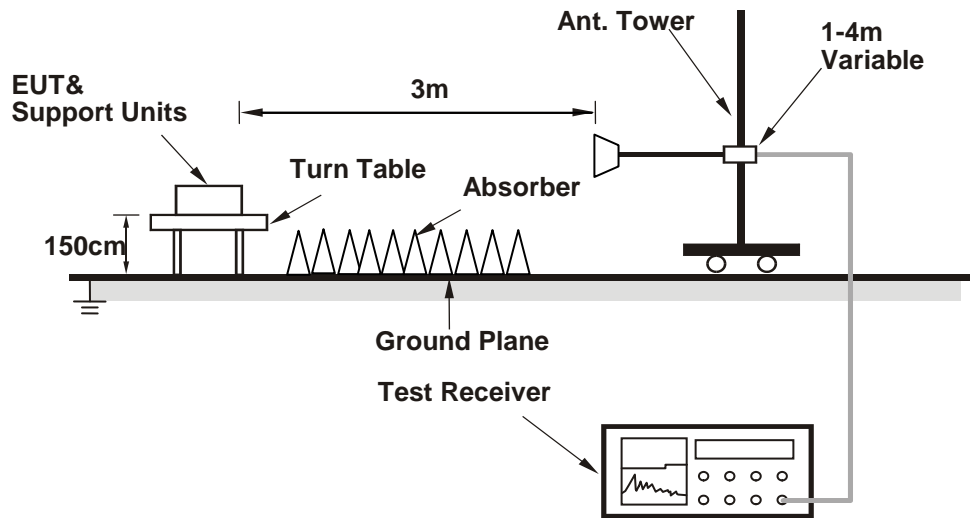

For the actual test configuration, please refer to the attached file (Test Setup Photo).

**4.1.6 EUT Operating Condition**

- a. Connected the EUT with the laptop which is placed on remote site.
- b. Contorlling software (Mtool 2.0.1.8.exe) has been activated to set the EUT on specific status.

## 4.1.7 Test Results (Mode 2)

## Above 1GHz Data:

## 802.11a

<b>CHANNEL</b>	TX Channel 52	<b>DETECTOR FUNCTION</b>	Peak (PK)
<b>FREQUENCY RANGE</b>	1GHz ~ 40GHz		Average (AV)

**ANTENNA POLARITY & TEST DISTANCE: HORIZONTAL AT 3 M**

NO.	FREQ. (MHz)	EMISSION LEVEL (dBuV/m)	LIMIT (dBuV/m)	MARGIN (dB)	ANTENNA HEIGHT (m)	TABLE ANGLE (Degree)	RAW VALUE (dBuV)	CORRECTION FACTOR (dB/m)
1	5038.00	50.8 PK	74.0	-23.2	2.94 H	156	49.5	1.3
2	5038.00	40.5 AV	54.0	-13.5	2.94 H	156	39.2	1.3
3	*5260.00	108.4 PK			2.94 H	156	106.7	1.7
4	*5260.00	99.2 AV			2.94 H	156	97.5	1.7
5	#10520.00	51.1 PK	74.0	-22.9	1.45 H	302	38.8	12.3
6	#10520.00	38.2 AV	54.0	-15.8	1.45 H	302	25.9	12.3
7	15780.00	53.7 PK	74.0	-20.3	2.14 H	99	40.6	13.1
8	15780.00	39.9 AV	54.0	-14.1	2.14 H	99	26.8	13.1

**ANTENNA POLARITY & TEST DISTANCE: VERTICAL AT 3 M**

NO.	FREQ. (MHz)	EMISSION LEVEL (dBuV/m)	LIMIT (dBuV/m)	MARGIN (dB)	ANTENNA HEIGHT (m)	TABLE ANGLE (Degree)	RAW VALUE (dBuV)	CORRECTION FACTOR (dB/m)
1	5038.00	56.6 PK	74.0	-17.4	2.02 V	167	55.3	1.3
2	5038.00	47.7 AV	54.0	-6.3	2.02 V	167	46.4	1.3
3	*5260.00	115.1 PK			2.02 V	167	113.4	1.7
4	*5260.00	105.8 AV			2.02 V	167	104.1	1.7
5	#10520.00	50.7 PK	74.0	-23.3	2.30 V	233	38.4	12.3
6	#10520.00	39.5 AV	54.0	-14.5	2.30 V	233	27.2	12.3
7	15780.00	55.8 PK	74.0	-18.2	1.00 V	185	42.7	13.1
8	15780.00	43.0 AV	54.0	-11.0	1.00 V	185	29.9	13.1

**REMARKS:**

1. Emission Level(dBuV/m) = Raw Value(dBuV) + Correction Factor(dB/m)
2. Correction Factor(dB/m) = Antenna Factor(dB/m) + Cable Factor(dB) – Pre-Amplifier Factor(dB)
3. The other emission levels were very low against the limit.
4. Margin value = Emission Level – Limit value
5. " \* ": Fundamental frequency.
6. " # ": The radiated frequency is out of the restricted band.

<b>CHANNEL</b>	TX Channel 60	<b>DETECTOR FUNCTION</b>	Peak (PK)
<b>FREQUENCY RANGE</b>	1GHz ~ 40GHz		Average (AV)

**ANTENNA POLARITY & TEST DISTANCE: HORIZONTAL AT 3 M**

NO.	FREQ. (MHz)	EMISSION LEVEL (dBuV/m)	LIMIT (dBuV/m)	MARGIN (dB)	ANTENNA HEIGHT (m)	TABLE ANGLE (Degree)	RAW VALUE (dBuV)	CORRECTION FACTOR (dB/m)
1	5079.00	51.2 PK	74.0	-22.8	2.93 H	146	49.9	1.3
2	5079.00	40.7 AV	54.0	-13.3	2.93 H	146	39.4	1.3
3	*5300.00	108.5 PK			2.93 H	146	106.7	1.8
4	*5300.00	99.2 AV			2.93 H	146	97.4	1.8
5	10600.00	51.6 PK	74.0	-22.4	1.42 H	287	39.1	12.5
6	10600.00	38.6 AV	54.0	-15.4	1.42 H	287	26.1	12.5
7	15900.00	53.6 PK	74.0	-20.4	2.08 H	109	40.6	13.0
8	15900.00	39.8 AV	54.0	-14.2	2.08 H	109	26.8	13.0

**ANTENNA POLARITY & TEST DISTANCE: VERTICAL AT 3 M**

NO.	FREQ. (MHz)	EMISSION LEVEL (dBuV/m)	LIMIT (dBuV/m)	MARGIN (dB)	ANTENNA HEIGHT (m)	TABLE ANGLE (Degree)	RAW VALUE (dBuV)	CORRECTION FACTOR (dB/m)
1	5079.00	57.5 PK	74.0	-16.5	1.98 V	155	56.2	1.3
2	5079.00	49.2 AV	54.0	-4.8	1.98 V	155	47.9	1.3
3	*5300.00	115.2 PK			1.98 V	155	113.4	1.8
4	*5300.00	105.9 AV			1.98 V	155	104.1	1.8
5	10600.00	50.2 PK	74.0	-23.8	2.30 V	242	37.7	12.5
6	10600.00	39.1 AV	54.0	-14.9	2.30 V	242	26.6	12.5
7	15900.00	55.5 PK	74.0	-18.5	1.05 V	189	42.5	13.0
8	15900.00	42.9 AV	54.0	-11.1	1.05 V	189	29.9	13.0

**REMARKS:**

1. Emission Level(dBuV/m) = Raw Value(dBuV) + Correction Factor(dB/m)
2. Correction Factor(dB/m) = Antenna Factor(dB/m) + Cable Factor(dB) – Pre-Amplifier Factor(dB)
3. The other emission levels were very low against the limit.
4. Margin value = Emission Level – Limit value
5. " \* ": Fundamental frequency.



<b>CHANNEL</b>	TX Channel 64	<b>DETECTOR FUNCTION</b>	Peak (PK)
<b>FREQUENCY RANGE</b>	1GHz ~ 40GHz		Average (AV)

**ANTENNA POLARITY & TEST DISTANCE: HORIZONTAL AT 3 M**

NO.	FREQ. (MHz)	EMISSION LEVEL (dBuV/m)	LIMIT (dBuV/m)	MARGIN (dB)	ANTENNA HEIGHT (m)	TABLE ANGLE (Degree)	RAW VALUE (dBuV)	CORRECTION FACTOR (dB/m)
1	*5320.00	107.8 PK			2.96 H	142	106.0	1.8
2	*5320.00	98.8 AV			2.96 H	142	97.0	1.8
3	5350.00	50.9 PK	74.0	-23.1	2.96 H	142	49.0	1.9
4	5350.00	40.5 AV	54.0	-13.5	2.96 H	142	38.6	1.9
5	10640.00	51.3 PK	74.0	-22.7	1.42 H	303	38.8	12.5
6	10640.00	38.4 AV	54.0	-15.6	1.42 H	303	25.9	12.5
7	15960.00	53.5 PK	74.0	-20.5	2.11 H	86	40.6	12.9
8	15960.00	39.8 AV	54.0	-14.2	2.11 H	86	26.9	12.9

**ANTENNA POLARITY & TEST DISTANCE: VERTICAL AT 3 M**

NO.	FREQ. (MHz)	EMISSION LEVEL (dBuV/m)	LIMIT (dBuV/m)	MARGIN (dB)	ANTENNA HEIGHT (m)	TABLE ANGLE (Degree)	RAW VALUE (dBuV)	CORRECTION FACTOR (dB/m)
1	*5320.00	114.7 PK			2.00 V	181	112.9	1.8
2	*5320.00	105.5 AV			2.00 V	181	103.7	1.8
3	5350.00	61.5 PK	74.0	-12.5	2.00 V	181	59.6	1.9
4	5350.00	47.3 AV	54.0	-6.7	2.00 V	181	45.4	1.9
5	10640.00	51.4 PK	74.0	-22.6	2.35 V	229	38.9	12.5
6	10640.00	39.9 AV	54.0	-14.1	2.35 V	229	27.4	12.5
7	15960.00	55.9 PK	74.0	-18.1	1.00 V	187	43.0	12.9
8	15960.00	42.9 AV	54.0	-11.1	1.00 V	187	30.0	12.9

**REMARKS:**

1. Emission Level(dBuV/m) = Raw Value(dBuV) + Correction Factor(dB/m)
2. Correction Factor(dB/m) = Antenna Factor(dB/m) + Cable Factor(dB) – Pre-Amplifier Factor(dB)
3. The other emission levels were very low against the limit.
4. Margin value = Emission Level – Limit value
5. " \* ": Fundamental frequency.

<b>CHANNEL</b>	TX Channel 100	<b>DETECTOR FUNCTION</b>	Peak (PK)
<b>FREQUENCY RANGE</b>	1GHz ~ 40GHz		Average (AV)

**ANTENNA POLARITY & TEST DISTANCE: HORIZONTAL AT 3 M**

NO.	FREQ. (MHz)	EMISSION LEVEL (dBuV/m)	LIMIT (dBuV/m)	MARGIN (dB)	ANTENNA HEIGHT (m)	TABLE ANGLE (Degree)	RAW VALUE (dBuV)	CORRECTION FACTOR (dB/m)
1	5418.00	50.9 PK	74.0	-23.1	2.91 H	164	48.8	2.1
2	5418.00	40.5 AV	54.0	-13.5	2.91 H	164	38.4	2.1
3	#5470.00	61.1 PK	74.0	-12.9	2.91 H	164	59.0	2.1
4	#5470.00	43.2 AV	54.0	-10.8	2.91 H	164	41.1	2.1
5	*5500.00	106.9 PK			2.91 H	164	104.8	2.1
6	*5500.00	97.8 AV			2.91 H	164	95.7	2.1
7	11000.00	51.5 PK	74.0	-22.5	1.40 H	304	38.3	13.2
8	11000.00	38.4 AV	54.0	-15.6	1.40 H	304	25.2	13.2
9	#16500.00	54.1 PK	74.0	-19.9	2.09 H	93	39.1	15.0
10	#16500.00	40.3 AV	54.0	-13.7	2.09 H	93	25.3	15.0

**ANTENNA POLARITY & TEST DISTANCE: VERTICAL AT 3 M**

NO.	FREQ. (MHz)	EMISSION LEVEL (dBuV/m)	LIMIT (dBuV/m)	MARGIN (dB)	ANTENNA HEIGHT (m)	TABLE ANGLE (Degree)	RAW VALUE (dBuV)	CORRECTION FACTOR (dB/m)
1	5418.00	62.1 PK	74.0	-11.9	2.11 V	94	60.0	2.1
2	5418.00	50.8 AV	54.0	-3.2	2.11 V	94	48.7	2.1
3	#5470.00	66.1 PK	74.0	-7.9	2.11 V	94	64.0	2.1
4	#5470.00	48.0 AV	54.0	-6.0	2.11 V	94	45.9	2.1
5	*5500.00	114.7 PK			2.11 V	94	112.6	2.1
6	*5500.00	104.8 AV			2.11 V	94	102.7	2.1
7	11000.00	51.0 PK	74.0	-23.0	2.27 V	225	37.8	13.2
8	11000.00	39.9 AV	54.0	-14.1	2.27 V	225	26.7	13.2
9	#16500.00	55.6 PK	74.0	-18.4	1.00 V	201	40.6	15.0
10	#16500.00	43.0 AV	54.0	-11.0	1.00 V	201	28.0	15.0

**REMARKS:**

- Emission Level(dBuV/m) = Raw Value(dBuV) + Correction Factor(dB/m)
- Correction Factor(dB/m) = Antenna Factor(dB/m) + Cable Factor(dB) – Pre-Amplifier Factor(dB)
- The other emission levels were very low against the limit.
- Margin value = Emission Level – Limit value
- " \* ": Fundamental frequency.
- " # ": The radiated frequency is out of the restricted band.

<b>CHANNEL</b>	TX Channel 116	<b>DETECTOR FUNCTION</b>	Peak (PK)
<b>FREQUENCY RANGE</b>	1GHz ~ 40GHz		Average (AV)

**ANTENNA POLARITY & TEST DISTANCE: HORIZONTAL AT 3 M**

NO.	FREQ. (MHz)	EMISSION LEVEL (dBuV/m)	LIMIT (dBuV/m)	MARGIN (dB)	ANTENNA HEIGHT (m)	TABLE ANGLE (Degree)	RAW VALUE (dBuV)	CORRECTION FACTOR (dB/m)
1	*5580.00	106.7 PK			2.86 H	173	104.4	2.3
2	*5580.00	97.5 AV			2.86 H	173	95.2	2.3
3	#5815.00	50.9 PK	74.0	-23.1	2.86 H	173	48.2	2.7
4	#5815.00	40.7 AV	54.0	-13.3	2.86 H	173	38.0	2.7
5	11160.00	50.7 PK	74.0	-23.3	1.40 H	305	37.6	13.1
6	11160.00	38.0 AV	54.0	-16.0	1.40 H	305	24.9	13.1
7	#16740.00	54.1 PK	74.0	-19.9	2.20 H	99	38.0	16.1
8	#16740.00	40.1 AV	54.0	-13.9	2.20 H	99	24.0	16.1

**ANTENNA POLARITY & TEST DISTANCE: VERTICAL AT 3 M**

NO.	FREQ. (MHz)	EMISSION LEVEL (dBuV/m)	LIMIT (dBuV/m)	MARGIN (dB)	ANTENNA HEIGHT (m)	TABLE ANGLE (Degree)	RAW VALUE (dBuV)	CORRECTION FACTOR (dB/m)
1	*5580.00	114.9 PK			2.05 V	84	112.6	2.3
2	*5580.00	105.0 AV			2.05 V	84	102.7	2.3
3	#5815.00	56.3 PK	74.0	-17.7	2.05 V	84	53.6	2.7
4	#5815.00	48.3 AV	54.0	-5.7	2.05 V	84	45.6	2.7
5	11160.00	50.7 PK	74.0	-23.3	2.32 V	228	37.6	13.1
6	11160.00	39.4 AV	54.0	-14.6	2.32 V	228	26.3	13.1
7	#16740.00	55.8 PK	74.0	-18.2	1.04 V	191	39.7	16.1
8	#16740.00	43.2 AV	54.0	-10.8	1.04 V	191	27.1	16.1

**REMARKS:**

1. Emission Level(dBuV/m) = Raw Value(dBuV) + Correction Factor(dB/m)
2. Correction Factor(dB/m) = Antenna Factor(dB/m) + Cable Factor(dB) – Pre-Amplifier Factor(dB)
3. The other emission levels were very low against the limit.
4. Margin value = Emission Level – Limit value
5. " \* ": Fundamental frequency.
6. " # ": The radiated frequency is out of the restricted band.

<b>CHANNEL</b>	TX Channel 140	<b>DETECTOR FUNCTION</b>	Peak (PK)
<b>FREQUENCY RANGE</b>	1GHz ~ 40GHz		Average (AV)

**ANTENNA POLARITY & TEST DISTANCE: HORIZONTAL AT 3 M**

NO.	FREQ. (MHz)	EMISSION LEVEL (dBuV/m)	LIMIT (dBuV/m)	MARGIN (dB)	ANTENNA HEIGHT (m)	TABLE ANGLE (Degree)	RAW VALUE (dBuV)	CORRECTION FACTOR (dB/m)
1	*5700.00	107.1 PK			2.90 H	159	104.4	2.7
2	*5700.00	98.0 AV			2.90 H	159	95.3	2.7
3	#5725.00	66.4 PK	74.0	-7.6	2.90 H	159	63.7	2.7
4	#5725.00	46.4 AV	54.0	-7.6	2.90 H	159	43.7	2.7
5	11400.00	51.3 PK	74.0	-22.7	1.51 H	304	38.0	13.3
6	11400.00	38.1 AV	54.0	-15.9	1.51 H	304	24.8	13.3
7	#17100.00	53.5 PK	74.0	-20.5	2.12 H	90	35.8	17.7
8	#17100.00	39.7 AV	54.0	-14.3	2.12 H	90	22.0	17.7

**ANTENNA POLARITY & TEST DISTANCE: VERTICAL AT 3 M**

NO.	FREQ. (MHz)	EMISSION LEVEL (dBuV/m)	LIMIT (dBuV/m)	MARGIN (dB)	ANTENNA HEIGHT (m)	TABLE ANGLE (Degree)	RAW VALUE (dBuV)	CORRECTION FACTOR (dB/m)
1	*5700.00	114.7 PK			2.06 V	89	112.0	2.7
2	*5700.00	105.1 AV			2.06 V	89	102.4	2.7
3	#5725.00	71.2 PK	74.0	-2.8	2.06 V	89	68.5	2.7
4	#5725.00	51.8 AV	54.0	-2.2	2.06 V	89	49.1	2.7
5	11400.00	50.2 PK	74.0	-23.8	2.31 V	220	36.9	13.3
6	11400.00	39.1 AV	54.0	-14.9	2.31 V	220	25.8	13.3
7	#17100.00	55.7 PK	74.0	-18.3	1.06 V	189	38.0	17.7
8	#17100.00	43.2 AV	54.0	-10.8	1.06 V	189	25.5	17.7

**REMARKS:**

1. Emission Level(dBuV/m) = Raw Value(dBuV) + Correction Factor(dB/m)
2. Correction Factor(dB/m) = Antenna Factor(dB/m) + Cable Factor(dB) – Pre-Amplifier Factor(dB)
3. The other emission levels were very low against the limit.
4. Margin value = Emission Level – Limit value
5. " \* ": Fundamental frequency.
6. " # ": The radiated frequency is out of the restricted band.

**802.11ac (VHT20)**

<b>CHANNEL</b>	TX Channel 52	<b>DETECTOR FUNCTION</b>	Peak (PK)
<b>FREQUENCY RANGE</b>	1GHz ~ 40GHz		Average (AV)

**ANTENNA POLARITY & TEST DISTANCE: HORIZONTAL AT 3 M**

NO.	FREQ. (MHz)	EMISSION LEVEL (dBuV/m)	LIMIT (dBuV/m)	MARGIN (dB)	ANTENNA HEIGHT (m)	TABLE ANGLE (Degree)	RAW VALUE (dBuV)	CORRECTION FACTOR (dB/m)
1	5038.00	51.1 PK	74.0	-22.9	2.88 H	155	49.8	1.3
2	5038.00	40.8 AV	54.0	-13.2	2.88 H	155	39.5	1.3
3	*5260.00	111.3 PK			2.88 H	155	109.6	1.7
4	*5260.00	100.3 AV			2.88 H	155	98.6	1.7
5	#10520.00	51.1 PK	74.0	-22.9	1.43 H	303	38.8	12.3
6	#10520.00	38.3 AV	54.0	-15.7	1.43 H	303	26.0	12.3
7	15780.00	53.3 PK	74.0	-20.7	2.18 H	95	40.2	13.1
8	15780.00	39.5 AV	54.0	-14.5	2.18 H	95	26.4	13.1

**ANTENNA POLARITY & TEST DISTANCE: VERTICAL AT 3 M**

NO.	FREQ. (MHz)	EMISSION LEVEL (dBuV/m)	LIMIT (dBuV/m)	MARGIN (dB)	ANTENNA HEIGHT (m)	TABLE ANGLE (Degree)	RAW VALUE (dBuV)	CORRECTION FACTOR (dB/m)
1	5038.00	56.6 PK	74.0	-17.4	1.87 V	180	55.3	1.3
2	5038.00	47.4 AV	54.0	-6.6	1.87 V	180	46.1	1.3
3	*5260.00	117.8 PK			1.87 V	180	116.1	1.7
4	*5260.00	106.9 AV			1.87 V	180	105.2	1.7
5	#10520.00	50.8 PK	74.0	-23.2	2.28 V	239	38.5	12.3
6	#10520.00	39.9 AV	54.0	-14.1	2.28 V	239	27.6	12.3
7	15780.00	56.0 PK	74.0	-18.0	1.00 V	171	42.9	13.1
8	15780.00	43.3 AV	54.0	-10.7	1.00 V	171	30.2	13.1

**REMARKS:**

- Emission Level(dBuV/m) = Raw Value(dBuV) + Correction Factor(dB/m)
- Correction Factor(dB/m) = Antenna Factor(dB/m) + Cable Factor(dB) – Pre-Amplifier Factor(dB)
- The other emission levels were very low against the limit.
- Margin value = Emission Level – Limit value
- " \* ": Fundamental frequency.
- " # ": The radiated frequency is out of the restricted band.

<b>CHANNEL</b>	TX Channel 60	<b>DETECTOR FUNCTION</b>	Peak (PK)
<b>FREQUENCY RANGE</b>	1GHz ~ 40GHz		Average (AV)

**ANTENNA POLARITY & TEST DISTANCE: HORIZONTAL AT 3 M**

NO.	FREQ. (MHz)	EMISSION LEVEL (dBuV/m)	LIMIT (dBuV/m)	MARGIN (dB)	ANTENNA HEIGHT (m)	TABLE ANGLE (Degree)	RAW VALUE (dBuV)	CORRECTION FACTOR (dB/m)
1	5079.00	50.8 PK	74.0	-23.2	2.88 H	163	49.5	1.3
2	5079.00	40.4 AV	54.0	-13.6	2.88 H	163	39.1	1.3
3	*5300.00	111.4 PK			2.88 H	163	109.6	1.8
4	*5300.00	100.4 AV			2.88 H	163	98.6	1.8
5	10600.00	51.1 PK	74.0	-22.9	1.46 H	301	38.6	12.5
6	10600.00	38.0 AV	54.0	-16.0	1.46 H	301	25.5	12.5
7	15900.00	54.2 PK	74.0	-19.8	2.18 H	113	41.2	13.0
8	15900.00	40.2 AV	54.0	-13.8	2.18 H	113	27.2	13.0

**ANTENNA POLARITY & TEST DISTANCE: VERTICAL AT 3 M**

NO.	FREQ. (MHz)	EMISSION LEVEL (dBuV/m)	LIMIT (dBuV/m)	MARGIN (dB)	ANTENNA HEIGHT (m)	TABLE ANGLE (Degree)	RAW VALUE (dBuV)	CORRECTION FACTOR (dB/m)
1	5079.00	57.1 PK	74.0	-16.9	1.90 V	165	55.8	1.3
2	5079.00	48.9 AV	54.0	-5.1	1.90 V	165	47.6	1.3
3	*5300.00	117.8 PK			1.90 V	165	116.0	1.8
4	*5300.00	107.2 AV			1.90 V	165	105.4	1.8
5	10600.00	50.4 PK	74.0	-23.6	2.25 V	217	37.9	12.5
6	10600.00	39.3 AV	54.0	-14.7	2.25 V	217	26.8	12.5
7	15900.00	55.9 PK	74.0	-18.1	1.00 V	171	42.9	13.0
8	15900.00	43.1 AV	54.0	-10.9	1.00 V	171	30.1	13.0

**REMARKS:**

1. Emission Level(dBuV/m) = Raw Value(dBuV) + Correction Factor(dB/m)
2. Correction Factor(dB/m) = Antenna Factor(dB/m) + Cable Factor(dB) – Pre-Amplifier Factor(dB)
3. The other emission levels were very low against the limit.
4. Margin value = Emission Level – Limit value
5. " \* ": Fundamental frequency.

<b>CHANNEL</b>	TX Channel 64	<b>DETECTOR FUNCTION</b>	Peak (PK)
<b>FREQUENCY RANGE</b>	1GHz ~ 40GHz		Average (AV)

**ANTENNA POLARITY & TEST DISTANCE: HORIZONTAL AT 3 M**

NO.	FREQ. (MHz)	EMISSION LEVEL (dBuV/m)	LIMIT (dBuV/m)	MARGIN (dB)	ANTENNA HEIGHT (m)	TABLE ANGLE (Degree)	RAW VALUE (dBuV)	CORRECTION FACTOR (dB/m)
1	*5320.00	110.8 PK			2.89 H	149	109.0	1.8
2	*5320.00	100.0 AV			2.89 H	149	98.2	1.8
3	5350.00	51.4 PK	74.0	-22.6	2.89 H	149	49.5	1.9
4	5350.00	40.8 AV	54.0	-13.2	2.89 H	149	38.9	1.9
5	10640.00	50.9 PK	74.0	-23.1	1.40 H	302	38.4	12.5
6	10640.00	38.2 AV	54.0	-15.8	1.40 H	302	25.7	12.5
7	15960.00	53.6 PK	74.0	-20.4	2.17 H	115	40.7	12.9
8	15960.00	39.8 AV	54.0	-14.2	2.17 H	115	26.9	12.9

**ANTENNA POLARITY & TEST DISTANCE: VERTICAL AT 3 M**

NO.	FREQ. (MHz)	EMISSION LEVEL (dBuV/m)	LIMIT (dBuV/m)	MARGIN (dB)	ANTENNA HEIGHT (m)	TABLE ANGLE (Degree)	RAW VALUE (dBuV)	CORRECTION FACTOR (dB/m)
1	*5320.00	118.3 PK			1.84 V	169	116.5	1.8
2	*5320.00	107.1 AV			1.84 V	169	105.3	1.8
3	5350.00	61.7 PK	74.0	-12.3	1.84 V	169	59.8	1.9
4	5350.00	47.2 AV	54.0	-6.8	1.84 V	169	45.3	1.9
5	10640.00	51.1 PK	74.0	-22.9	2.31 V	223	38.6	12.5
6	10640.00	40.0 AV	54.0	-14.0	2.31 V	223	27.5	12.5
7	15960.00	56.2 PK	74.0	-17.8	1.01 V	173	43.3	12.9
8	15960.00	43.3 AV	54.0	-10.7	1.01 V	173	30.4	12.9

**REMARKS:**

1. Emission Level(dBuV/m) = Raw Value(dBuV) + Correction Factor(dB/m)
2. Correction Factor(dB/m) = Antenna Factor(dB/m) + Cable Factor(dB) – Pre-Amplifier Factor(dB)
3. The other emission levels were very low against the limit.
4. Margin value = Emission Level – Limit value
5. " \* ": Fundamental frequency.

<b>CHANNEL</b>	TX Channel 100	<b>DETECTOR FUNCTION</b>	Peak (PK)
<b>FREQUENCY RANGE</b>	1GHz ~ 40GHz		Average (AV)

**ANTENNA POLARITY & TEST DISTANCE: HORIZONTAL AT 3 M**

NO.	FREQ. (MHz)	EMISSION LEVEL (dBuV/m)	LIMIT (dBuV/m)	MARGIN (dB)	ANTENNA HEIGHT (m)	TABLE ANGLE (Degree)	RAW VALUE (dBuV)	CORRECTION FACTOR (dB/m)
1	5418.00	50.9 PK	74.0	-23.1	2.88 H	150	48.8	2.1
2	5418.00	40.4 AV	54.0	-13.6	2.88 H	150	38.3	2.1
3	#5470.00	59.8 PK	74.0	-14.2	2.88 H	150	57.7	2.1
4	#5470.00	42.1 AV	54.0	-11.9	2.88 H	150	40.0	2.1
5	*5500.00	108.6 PK			2.88 H	150	106.5	2.1
6	*5500.00	98.1 AV			2.88 H	150	96.0	2.1
7	11000.00	50.8 PK	74.0	-23.2	1.41 H	315	37.6	13.2
8	11000.00	38.0 AV	54.0	-16.0	1.41 H	315	24.8	13.2
9	#16500.00	53.9 PK	74.0	-20.1	2.13 H	86	38.9	15.0
10	#16500.00	40.0 AV	54.0	-14.0	2.13 H	86	25.0	15.0

**ANTENNA POLARITY & TEST DISTANCE: VERTICAL AT 3 M**

NO.	FREQ. (MHz)	EMISSION LEVEL (dBuV/m)	LIMIT (dBuV/m)	MARGIN (dB)	ANTENNA HEIGHT (m)	TABLE ANGLE (Degree)	RAW VALUE (dBuV)	CORRECTION FACTOR (dB/m)
1	5418.00	62.1 PK	74.0	-11.9	1.84 V	160	60.0	2.1
2	5418.00	50.8 AV	54.0	-3.2	1.84 V	160	48.7	2.1
3	#5470.00	65.7 PK	74.0	-8.3	1.84 V	160	63.6	2.1
4	#5470.00	47.7 AV	54.0	-6.3	1.84 V	160	45.6	2.1
5	*5500.00	115.7 PK			1.84 V	160	113.6	2.1
6	*5500.00	105.7 AV			1.84 V	160	103.6	2.1
7	11000.00	51.1 PK	74.0	-22.9	2.29 V	244	37.9	13.2
8	11000.00	39.8 AV	54.0	-14.2	2.29 V	244	26.6	13.2
9	#16500.00	55.2 PK	74.0	-18.8	1.05 V	178	40.2	15.0
10	#16500.00	42.7 AV	54.0	-11.3	1.05 V	178	27.7	15.0

**REMARKS:**

1. Emission Level(dBuV/m) = Raw Value(dBuV) + Correction Factor(dB/m)
2. Correction Factor(dB/m) = Antenna Factor(dB/m) + Cable Factor(dB) – Pre-Amplifier Factor(dB)
3. The other emission levels were very low against the limit.
4. Margin value = Emission Level – Limit value
5. " \* ": Fundamental frequency.
6. " # ": The radiated frequency is out of the restricted band.



<b>CHANNEL</b>	TX Channel 116	<b>DETECTOR FUNCTION</b>	Peak (PK)
<b>FREQUENCY RANGE</b>	1GHz ~ 40GHz		Average (AV)

**ANTENNA POLARITY & TEST DISTANCE: HORIZONTAL AT 3 M**

NO.	FREQ. (MHz)	EMISSION LEVEL (dBuV/m)	LIMIT (dBuV/m)	MARGIN (dB)	ANTENNA HEIGHT (m)	TABLE ANGLE (Degree)	RAW VALUE (dBuV)	CORRECTION FACTOR (dB/m)
1	*5580.00	108.9 PK			2.87 H	146	106.6	2.3
2	*5580.00	98.4 AV			2.87 H	146	96.1	2.3
3	#5815.00	50.9 PK	74.0	-23.1	2.87 H	146	48.2	2.7
4	#5815.00	40.4 AV	54.0	-13.6	2.87 H	146	37.7	2.7
5	11160.00	50.7 PK	74.0	-23.3	1.40 H	288	37.6	13.1
6	11160.00	38.0 AV	54.0	-16.0	1.40 H	288	24.9	13.1
7	#16740.00	54.0 PK	74.0	-20.0	2.13 H	103	37.9	16.1
8	#16740.00	39.9 AV	54.0	-14.1	2.13 H	103	23.8	16.1

**ANTENNA POLARITY & TEST DISTANCE: VERTICAL AT 3 M**

NO.	FREQ. (MHz)	EMISSION LEVEL (dBuV/m)	LIMIT (dBuV/m)	MARGIN (dB)	ANTENNA HEIGHT (m)	TABLE ANGLE (Degree)	RAW VALUE (dBuV)	CORRECTION FACTOR (dB/m)
1	*5580.00	115.6 PK			1.88 V	157	113.3	2.3
2	*5580.00	105.5 AV			1.88 V	157	103.2	2.3
3	#5815.00	56.8 PK	74.0	-17.2	1.88 V	157	54.1	2.7
4	#5815.00	48.5 AV	54.0	-5.5	1.88 V	157	45.8	2.7
5	11160.00	51.0 PK	74.0	-23.0	2.31 V	227	37.9	13.1
6	11160.00	39.8 AV	54.0	-14.2	2.31 V	227	26.7	13.1
7	#16740.00	55.9 PK	74.0	-18.1	1.01 V	189	39.8	16.1
8	#16740.00	42.8 AV	54.0	-11.2	1.01 V	189	26.7	16.1

**REMARKS:**

1. Emission Level(dBuV/m) = Raw Value(dBuV) + Correction Factor(dB/m)
2. Correction Factor(dB/m) = Antenna Factor(dB/m) + Cable Factor(dB) – Pre-Amplifier Factor(dB)
3. The other emission levels were very low against the limit.
4. Margin value = Emission Level – Limit value
5. " \* ": Fundamental frequency.
6. " # ": The radiated frequency is out of the restricted band.

<b>CHANNEL</b>	TX Channel 140	<b>DETECTOR FUNCTION</b>	Peak (PK)
<b>FREQUENCY RANGE</b>	1GHz ~ 40GHz		Average (AV)

**ANTENNA POLARITY & TEST DISTANCE: HORIZONTAL AT 3 M**

NO.	FREQ. (MHz)	EMISSION LEVEL (dBuV/m)	LIMIT (dBuV/m)	MARGIN (dB)	ANTENNA HEIGHT (m)	TABLE ANGLE (Degree)	RAW VALUE (dBuV)	CORRECTION FACTOR (dB/m)
1	*5700.00	108.8 PK			2.90 H	153	106.1	2.7
2	*5700.00	98.1 AV			2.90 H	153	95.4	2.7
3	#5725.00	65.1 PK	74.0	-8.9	2.90 H	153	62.4	2.7
4	#5725.00	46.3 AV	54.0	-7.7	2.90 H	153	43.6	2.7
5	11400.00	50.8 PK	74.0	-23.2	1.47 H	300	37.5	13.3
6	11400.00	38.1 AV	54.0	-15.9	1.47 H	300	24.8	13.3
7	#17100.00	53.8 PK	74.0	-20.2	2.13 H	108	36.1	17.7
8	#17100.00	39.9 AV	54.0	-14.1	2.13 H	108	22.2	17.7

**ANTENNA POLARITY & TEST DISTANCE: VERTICAL AT 3 M**

NO.	FREQ. (MHz)	EMISSION LEVEL (dBuV/m)	LIMIT (dBuV/m)	MARGIN (dB)	ANTENNA HEIGHT (m)	TABLE ANGLE (Degree)	RAW VALUE (dBuV)	CORRECTION FACTOR (dB/m)
1	*5700.00	115.4 PK			1.85 V	164	112.7	2.7
2	*5700.00	105.2 AV			1.85 V	164	102.5	2.7
3	#5725.00	70.7 PK	74.0	-3.3	1.85 V	164	68.0	2.7
4	#5725.00	51.5 AV	54.0	-2.5	1.85 V	164	48.8	2.7
5	11400.00	50.1 PK	74.0	-23.9	2.30 V	243	36.8	13.3
6	11400.00	39.1 AV	54.0	-14.9	2.30 V	243	25.8	13.3
7	#17100.00	55.9 PK	74.0	-18.1	1.00 V	179	38.2	17.7
8	#17100.00	43.3 AV	54.0	-10.7	1.00 V	179	25.6	17.7

**REMARKS:**

1. Emission Level(dBuV/m) = Raw Value(dBuV) + Correction Factor(dB/m)
2. Correction Factor(dB/m) = Antenna Factor(dB/m) + Cable Factor(dB) – Pre-Amplifier Factor(dB)
3. The other emission levels were very low against the limit.
4. Margin value = Emission Level – Limit value
5. " \* ": Fundamental frequency.
6. " # ": The radiated frequency is out of the restricted band.

802.11ac (VHT40)

<b>CHANNEL</b>	TX Channel 54	<b>DETECTOR FUNCTION</b>	Peak (PK)
<b>FREQUENCY RANGE</b>	1GHz ~ 40GHz		Average (AV)

ANTENNA POLARITY & TEST DISTANCE: HORIZONTAL AT 3 M								
NO.	FREQ. (MHz)	EMISSION LEVEL (dBuV/m)	LIMIT (dBuV/m)	MARGIN (dB)	ANTENNA HEIGHT (m)	TABLE ANGLE (Degree)	RAW VALUE (dBuV)	CORRECTION FACTOR (dB/m)
1	5150.00	51.4 PK	74.0	-22.6	2.89 H	143	49.9	1.5
2	5150.00	40.8 AV	54.0	-13.2	2.89 H	143	39.3	1.5
3	*5270.00	106.4 PK			2.89 H	143	104.6	1.8
4	*5270.00	95.8 AV			2.89 H	143	94.0	1.8
5	#10540.00	51.5 PK	74.0	-22.5	1.42 H	302	39.2	12.3
6	#10540.00	38.5 AV	54.0	-15.5	1.42 H	302	26.2	12.3
7	15810.00	53.8 PK	74.0	-20.2	2.12 H	102	40.8	13.0
8	15810.00	39.8 AV	54.0	-14.2	2.12 H	102	26.8	13.0

ANTENNA POLARITY & TEST DISTANCE: VERTICAL AT 3 M								
NO.	FREQ. (MHz)	EMISSION LEVEL (dBuV/m)	LIMIT (dBuV/m)	MARGIN (dB)	ANTENNA HEIGHT (m)	TABLE ANGLE (Degree)	RAW VALUE (dBuV)	CORRECTION FACTOR (dB/m)
1	5150.00	56.6 PK	74.0	-17.4	1.88 V	169	55.1	1.5
2	5150.00	47.2 AV	54.0	-6.8	1.88 V	169	45.7	1.5
3	*5270.00	113.8 PK			1.88 V	169	112.0	1.8
4	*5270.00	102.7 AV			1.88 V	169	100.9	1.8
5	#10540.00	50.6 PK	74.0	-23.4	2.29 V	249	38.3	12.3
6	#10540.00	37.8 AV	54.0	-16.2	2.29 V	249	25.5	12.3
7	15810.00	53.4 PK	74.0	-20.6	1.00 V	172	40.4	13.0
8	15810.00	39.8 AV	54.0	-14.2	1.00 V	172	26.8	13.0

**REMARKS:**

1. Emission Level(dBuV/m) = Raw Value(dBuV) + Correction Factor(dB/m)
2. Correction Factor(dB/m) = Antenna Factor(dB/m) + Cable Factor(dB) – Pre-Amplifier Factor(dB)
3. The other emission levels were very low against the limit.
4. Margin value = Emission Level – Limit value
5. " \* ": Fundamental frequency.
6. " # ": The radiated frequency is out of the restricted band.

<b>CHANNEL</b>	TX Channel 62	<b>DETECTOR FUNCTION</b>	Peak (PK)
<b>FREQUENCY RANGE</b>	1GHz ~ 40GHz		Average (AV)

**ANTENNA POLARITY & TEST DISTANCE: HORIZONTAL AT 3 M**

NO.	FREQ. (MHz)	EMISSION LEVEL (dBuV/m)	LIMIT (dBuV/m)	MARGIN (dB)	ANTENNA HEIGHT (m)	TABLE ANGLE (Degree)	RAW VALUE (dBuV)	CORRECTION FACTOR (dB/m)
1	*5310.00	105.9 PK			2.85 H	157	104.1	1.8
2	*5310.00	95.1 AV			2.85 H	157	93.3	1.8
3	5350.00	68.2 PK	74.0	-5.8	2.85 H	157	66.3	1.9
4	5350.00	47.7 AV	54.0	-6.3	2.85 H	157	45.8	1.9
5	10620.00	50.9 PK	74.0	-23.1	1.44 H	290	38.4	12.5
6	10620.00	38.1 AV	54.0	-15.9	1.44 H	290	25.6	12.5
7	15930.00	54.0 PK	74.0	-20.0	2.13 H	109	41.0	13.0
8	15930.00	40.4 AV	54.0	-13.6	2.13 H	109	27.4	13.0

**ANTENNA POLARITY & TEST DISTANCE: VERTICAL AT 3 M**

NO.	FREQ. (MHz)	EMISSION LEVEL (dBuV/m)	LIMIT (dBuV/m)	MARGIN (dB)	ANTENNA HEIGHT (m)	TABLE ANGLE (Degree)	RAW VALUE (dBuV)	CORRECTION FACTOR (dB/m)
1	*5310.00	113.3 PK			1.94 V	176	111.5	1.8
2	*5310.00	102.2 AV			1.94 V	176	100.4	1.8
3	5350.00	73.7 PK	74.0	-0.3	1.94 V	176	71.8	1.9
4	5350.00	53.1 AV	54.0	-0.9	1.94 V	176	51.2	1.9
5	10620.00	51.0 PK	74.0	-23.0	2.34 V	261	38.5	12.5
6	10620.00	38.2 AV	54.0	-15.8	2.34 V	261	25.7	12.5
7	15930.00	53.6 PK	74.0	-20.4	1.00 V	165	40.6	13.0
8	15930.00	40.0 AV	54.0	-14.0	1.00 V	165	27.0	13.0

**REMARKS:**

1. Emission Level(dBuV/m) = Raw Value(dBuV) + Correction Factor(dB/m)
2. Correction Factor(dB/m) = Antenna Factor(dB/m) + Cable Factor(dB) – Pre-Amplifier Factor(dB)
3. The other emission levels were very low against the limit.
4. Margin value = Emission Level – Limit value
5. " \* ": Fundamental frequency.

<b>CHANNEL</b>	TX Channel 102	<b>DETECTOR FUNCTION</b>	Peak (PK)
<b>FREQUENCY RANGE</b>	1GHz ~ 40GHz		Average (AV)

**ANTENNA POLARITY & TEST DISTANCE: HORIZONTAL AT 3 M**

NO.	FREQ. (MHz)	EMISSION LEVEL (dBuV/m)	LIMIT (dBuV/m)	MARGIN (dB)	ANTENNA HEIGHT (m)	TABLE ANGLE (Degree)	RAW VALUE (dBuV)	CORRECTION FACTOR (dB/m)
1	#5470.00	67.9 PK	74.0	-6.1	2.90 H	147	65.8	2.1
2	#5470.00	47.2 AV	54.0	-6.8	2.90 H	147	45.1	2.1
3	*5510.00	104.2 PK			2.90 H	147	102.1	2.1
4	*5510.00	93.1 AV			2.90 H	147	91.0	2.1
5	11020.00	51.1 PK	74.0	-22.9	1.50 H	287	37.9	13.2
6	11020.00	38.3 AV	54.0	-15.7	1.50 H	287	25.1	13.2
7	#16530.00	53.2 PK	74.0	-20.8	2.20 H	111	37.8	15.4
8	#16530.00	39.6 AV	54.0	-14.4	2.20 H	111	24.2	15.4

**ANTENNA POLARITY & TEST DISTANCE: VERTICAL AT 3 M**

NO.	FREQ. (MHz)	EMISSION LEVEL (dBuV/m)	LIMIT (dBuV/m)	MARGIN (dB)	ANTENNA HEIGHT (m)	TABLE ANGLE (Degree)	RAW VALUE (dBuV)	CORRECTION FACTOR (dB/m)
1	#5470.00	73.4 PK	74.0	-0.6	2.43 V	357	71.3	2.1
2	#5470.00	52.1 AV	54.0	-1.9	2.43 V	357	50.0	2.1
3	*5510.00	111.4 PK			2.43 V	357	109.3	2.1
4	*5510.00	100.2 AV			2.43 V	357	98.1	2.1
5	11020.00	50.3 PK	74.0	-23.7	2.32 V	262	37.1	13.2
6	11020.00	37.7 AV	54.0	-16.3	2.32 V	262	24.5	13.2
7	#16530.00	53.0 PK	74.0	-21.0	1.00 V	184	37.6	15.4
8	#16530.00	39.5 AV	54.0	-14.5	1.00 V	184	24.1	15.4

**REMARKS:**

1. Emission Level(dBuV/m) = Raw Value(dBuV) + Correction Factor(dB/m)
2. Correction Factor(dB/m) = Antenna Factor(dB/m) + Cable Factor(dB) – Pre-Amplifier Factor(dB)
3. The other emission levels were very low against the limit.
4. Margin value = Emission Level – Limit value
5. " \* ": Fundamental frequency.
6. " # ": The radiated frequency is out of the restricted band.

<b>CHANNEL</b>	TX Channel 110	<b>DETECTOR FUNCTION</b>	Peak (PK)
<b>FREQUENCY RANGE</b>	1GHz ~ 40GHz		Average (AV)

**ANTENNA POLARITY & TEST DISTANCE: HORIZONTAL AT 3 M**

NO.	FREQ. (MHz)	EMISSION LEVEL (dBuV/m)	LIMIT (dBuV/m)	MARGIN (dB)	ANTENNA HEIGHT (m)	TABLE ANGLE (Degree)	RAW VALUE (dBuV)	CORRECTION FACTOR (dB/m)
1	*5550.00	105.3 PK			2.92 H	140	103.0	2.3
2	*5550.00	94.2 AV			2.92 H	140	91.9	2.3
3	11100.00	50.9 PK	74.0	-23.1	1.43 H	314	37.9	13.0
4	11100.00	38.1 AV	54.0	-15.9	1.43 H	314	25.1	13.0
5	#16650.00	53.6 PK	74.0	-20.4	2.18 H	89	37.5	16.1
6	#16650.00	39.6 AV	54.0	-14.4	2.18 H	89	23.5	16.1

**ANTENNA POLARITY & TEST DISTANCE: VERTICAL AT 3 M**

NO.	FREQ. (MHz)	EMISSION LEVEL (dBuV/m)	LIMIT (dBuV/m)	MARGIN (dB)	ANTENNA HEIGHT (m)	TABLE ANGLE (Degree)	RAW VALUE (dBuV)	CORRECTION FACTOR (dB/m)
1	*5550.00	112.5 PK			2.08 V	357	110.2	2.3
2	*5550.00	101.5 AV			2.08 V	357	99.2	2.3
3	11100.00	50.6 PK	74.0	-23.4	2.33 V	238	37.6	13.0
4	11100.00	38.0 AV	54.0	-16.0	2.33 V	238	25.0	13.0
5	#16650.00	53.4 PK	74.0	-20.6	1.00 V	168	37.3	16.1
6	#16650.00	39.9 AV	54.0	-14.1	1.00 V	168	23.8	16.1

**REMARKS:**

1. Emission Level(dBuV/m) = Raw Value(dBuV) + Correction Factor(dB/m)
2. Correction Factor(dB/m) = Antenna Factor(dB/m) + Cable Factor(dB) – Pre-Amplifier Factor(dB)
3. The other emission levels were very low against the limit.
4. Margin value = Emission Level – Limit value
5. " \* ": Fundamental frequency.
6. " # ": The radiated frequency is out of the restricted band.

<b>CHANNEL</b>	TX Channel 134	<b>DETECTOR FUNCTION</b>	Peak (PK)
<b>FREQUENCY RANGE</b>	1GHz ~ 40GHz		Average (AV)

**ANTENNA POLARITY & TEST DISTANCE: HORIZONTAL AT 3 M**

NO.	FREQ. (MHz)	EMISSION LEVEL (dBuV/m)	LIMIT (dBuV/m)	MARGIN (dB)	ANTENNA HEIGHT (m)	TABLE ANGLE (Degree)	RAW VALUE (dBuV)	CORRECTION FACTOR (dB/m)
1	*5670.00	105.2 PK			2.84 H	159	102.7	2.5
2	*5670.00	94.1 AV			2.84 H	159	91.6	2.5
3	#5725.00	64.2 PK	74.0	-9.8	2.84 H	159	61.5	2.7
4	#5725.00	46.1 AV	54.0	-7.9	2.84 H	159	43.4	2.7
5	11340.00	50.3 PK	74.0	-23.7	1.49 H	302	36.7	13.6
6	11340.00	37.7 AV	54.0	-16.3	1.49 H	302	24.1	13.6
7	#17010.00	53.7 PK	74.0	-20.3	2.19 H	106	35.9	17.8
8	#17010.00	39.7 AV	54.0	-14.3	2.19 H	106	21.9	17.8

**ANTENNA POLARITY & TEST DISTANCE: VERTICAL AT 3 M**

NO.	FREQ. (MHz)	EMISSION LEVEL (dBuV/m)	LIMIT (dBuV/m)	MARGIN (dB)	ANTENNA HEIGHT (m)	TABLE ANGLE (Degree)	RAW VALUE (dBuV)	CORRECTION FACTOR (dB/m)
1	*5670.00	112.2 PK			2.08 V	356	109.7	2.5
2	*5670.00	101.1 AV			2.08 V	356	98.6	2.5
3	#5725.00	69.5 PK	74.0	-4.5	2.08 V	356	66.8	2.7
4	#5725.00	51.1 AV	54.0	-2.9	2.08 V	356	48.4	2.7
5	11340.00	50.1 PK	74.0	-23.9	2.24 V	236	36.5	13.6
6	11340.00	37.3 AV	54.0	-16.7	2.24 V	236	23.7	13.6
7	#17010.00	53.6 PK	74.0	-20.4	1.00 V	172	35.8	17.8
8	#17010.00	40.2 AV	54.0	-13.8	1.00 V	172	22.4	17.8

**REMARKS:**

1. Emission Level(dBuV/m) = Raw Value(dBuV) + Correction Factor(dB/m)
2. Correction Factor(dB/m) = Antenna Factor(dB/m) + Cable Factor(dB) – Pre-Amplifier Factor(dB)
3. The other emission levels were very low against the limit.
4. Margin value = Emission Level – Limit value
5. " \* ": Fundamental frequency.
6. " # ": The radiated frequency is out of the restricted band.

**802.11ac (VHT80)**

<b>CHANNEL</b>	TX Channel 58	<b>DETECTOR FUNCTION</b>	Peak (PK)
<b>FREQUENCY RANGE</b>	1GHz ~ 40GHz		Average (AV)

**ANTENNA POLARITY & TEST DISTANCE: HORIZONTAL AT 3 M**

NO.	FREQ. (MHz)	EMISSION LEVEL (dBuV/m)	LIMIT (dBuV/m)	MARGIN (dB)	ANTENNA HEIGHT (m)	TABLE ANGLE (Degree)	RAW VALUE (dBuV)	CORRECTION FACTOR (dB/m)
1	5150.00	50.5 PK	74.0	-23.5	2.89 H	144	49.0	1.5
2	5150.00	40.5 AV	54.0	-13.5	2.89 H	144	39.0	1.5
3	*5290.00	103.1 PK			2.89 H	144	101.3	1.8
4	*5290.00	91.1 AV			2.89 H	144	89.3	1.8
5	5350.00	66.4 PK	74.0	-7.6	2.89 H	144	64.5	1.9
6	5350.00	48.1 AV	54.0	-5.9	2.89 H	144	46.2	1.9
7	#10580.00	50.7 PK	74.0	-23.3	1.47 H	299	38.3	12.4
8	#10580.00	37.9 AV	54.0	-16.1	1.47 H	299	25.5	12.4
9	15870.00	54.1 PK	74.0	-19.9	2.15 H	91	41.1	13.0
10	15870.00	40.3 AV	54.0	-13.7	2.15 H	91	27.3	13.0

**ANTENNA POLARITY & TEST DISTANCE: VERTICAL AT 3 M**

NO.	FREQ. (MHz)	EMISSION LEVEL (dBuV/m)	LIMIT (dBuV/m)	MARGIN (dB)	ANTENNA HEIGHT (m)	TABLE ANGLE (Degree)	RAW VALUE (dBuV)	CORRECTION FACTOR (dB/m)
1	5150.00	58.5 PK	74.0	-15.5	1.87 V	174	57.0	1.5
2	5150.00	44.7 AV	54.0	-9.3	1.87 V	174	43.2	1.5
3	*5290.00	109.4 PK			1.87 V	174	107.6	1.8
4	*5290.00	97.2 AV			1.87 V	174	95.4	1.8
5	5350.00	71.8 PK	74.0	-2.2	1.87 V	174	69.9	1.9
6	5350.00	53.5 AV	54.0	-0.5	1.87 V	174	51.6	1.9
7	#10580.00	50.3 PK	74.0	-23.7	2.28 V	238	37.9	12.4
8	#10580.00	37.5 AV	54.0	-16.5	2.28 V	238	25.1	12.4
9	15870.00	53.2 PK	74.0	-20.8	1.00 V	165	40.2	13.0
10	15870.00	39.5 AV	54.0	-14.5	1.00 V	165	26.5	13.0

**REMARKS:**

- Emission Level(dBuV/m) = Raw Value(dBuV) + Correction Factor(dB/m)
- Correction Factor(dB/m) = Antenna Factor(dB/m) + Cable Factor(dB) – Pre-Amplifier Factor(dB)
- The other emission levels were very low against the limit.
- Margin value = Emission Level – Limit value
- " \* ": Fundamental frequency.
- " # ": The radiated frequency is out of the restricted band.



<b>CHANNEL</b>	TX Channel 106	<b>DETECTOR FUNCTION</b>	Peak (PK)
<b>FREQUENCY RANGE</b>	1GHz ~ 40GHz		Average (AV)

**ANTENNA POLARITY & TEST DISTANCE: HORIZONTAL AT 3 M**

NO.	FREQ. (MHz)	EMISSION LEVEL (dBuV/m)	LIMIT (dBuV/m)	MARGIN (dB)	ANTENNA HEIGHT (m)	TABLE ANGLE (Degree)	RAW VALUE (dBuV)	CORRECTION FACTOR (dB/m)
1	#5470.00	67.9 PK	74.0	-6.1	2.94 H	137	65.8	2.1
2	#5470.00	47.2 AV	54.0	-6.8	2.94 H	137	45.1	2.1
3	*5530.00	100.2 PK			2.94 H	137	98.0	2.2
4	*5530.00	89.7 AV			2.94 H	137	87.5	2.2
5	11060.00	51.8 PK	74.0	-22.2	1.49 H	300	38.7	13.1
6	11060.00	38.6 AV	54.0	-15.4	1.49 H	300	25.5	13.1
7	#16590.00	54.2 PK	74.0	-19.8	2.16 H	113	38.0	16.2
8	#16590.00	40.3 AV	54.0	-13.7	2.16 H	113	24.1	16.2

**ANTENNA POLARITY & TEST DISTANCE: VERTICAL AT 3 M**

NO.	FREQ. (MHz)	EMISSION LEVEL (dBuV/m)	LIMIT (dBuV/m)	MARGIN (dB)	ANTENNA HEIGHT (m)	TABLE ANGLE (Degree)	RAW VALUE (dBuV)	CORRECTION FACTOR (dB/m)
1	#5470.00	73.8 PK	74.0	-0.2	2.21 V	358	71.7	2.1
2	#5470.00	52.8 AV	54.0	-1.2	2.21 V	358	50.7	2.1
3	*5530.00	108.8 PK			2.21 V	358	106.6	2.2
4	*5530.00	95.5 AV			2.21 V	358	93.3	2.2
5	11060.00	50.4 PK	74.0	-23.6	2.33 V	252	37.3	13.1
6	11060.00	37.9 AV	54.0	-16.1	2.33 V	252	24.8	13.1
7	#16590.00	53.8 PK	74.0	-20.2	1.00 V	161	37.6	16.2
8	#16590.00	40.0 AV	54.0	-14.0	1.00 V	161	23.8	16.2

**REMARKS:**

1. Emission Level(dBuV/m) = Raw Value(dBuV) + Correction Factor(dB/m)
2. Correction Factor(dB/m) = Antenna Factor(dB/m) + Cable Factor(dB) – Pre-Amplifier Factor(dB)
3. The other emission levels were very low against the limit.
4. Margin value = Emission Level – Limit value
5. " \* ": Fundamental frequency.
6. " # ": The radiated frequency is out of the restricted band.

<b>CHANNEL</b>	TX Channel 122	<b>DETECTOR FUNCTION</b>	Peak (PK)
<b>FREQUENCY RANGE</b>	1GHz ~ 40GHz		Average (AV)

**ANTENNA POLARITY & TEST DISTANCE: HORIZONTAL AT 3 M**

NO.	FREQ. (MHz)	EMISSION LEVEL (dBuV/m)	LIMIT (dBuV/m)	MARGIN (dB)	ANTENNA HEIGHT (m)	TABLE ANGLE (Degree)	RAW VALUE (dBuV)	CORRECTION FACTOR (dB/m)
1	*5610.00	101.3 PK			2.88 H	131	98.8	2.5
2	*5610.00	89.7 AV			2.88 H	131	87.2	2.5
3	#5725.00	59.4 PK	74.0	-14.6	2.88 H	131	56.7	2.7
4	#5725.00	44.8 AV	54.0	-9.2	2.88 H	131	42.1	2.7
5	11220.00	51.3 PK	74.0	-22.7	1.40 H	292	38.0	13.3
6	11220.00	38.7 AV	54.0	-15.3	1.40 H	292	25.4	13.3
7	#16830.00	54.0 PK	74.0	-20.0	2.13 H	109	37.3	16.7
8	#16830.00	40.1 AV	54.0	-13.9	2.13 H	109	23.4	16.7

**ANTENNA POLARITY & TEST DISTANCE: VERTICAL AT 3 M**

NO.	FREQ. (MHz)	EMISSION LEVEL (dBuV/m)	LIMIT (dBuV/m)	MARGIN (dB)	ANTENNA HEIGHT (m)	TABLE ANGLE (Degree)	RAW VALUE (dBuV)	CORRECTION FACTOR (dB/m)
1	*5610.00	109.0 PK			2.04 V	355	106.5	2.5
2	*5610.00	96.5 AV			2.04 V	355	94.0	2.5
3	#5725.00	64.8 PK	74.0	-9.2	2.04 V	355	62.1	2.7
4	#5725.00	50.1 AV	54.0	-3.9	2.04 V	355	47.4	2.7
5	11220.00	51.0 PK	74.0	-23.0	2.24 V	236	37.7	13.3
6	11220.00	38.2 AV	54.0	-15.8	2.24 V	236	24.9	13.3
7	#16830.00	53.9 PK	74.0	-20.1	1.00 V	167	37.2	16.7
8	#16830.00	40.1 AV	54.0	-13.9	1.00 V	167	23.4	16.7

**REMARKS:**

1. Emission Level(dBuV/m) = Raw Value(dBuV) + Correction Factor(dB/m)
2. Correction Factor(dB/m) = Antenna Factor(dB/m) + Cable Factor(dB) – Pre-Amplifier Factor(dB)
3. The other emission levels were very low against the limit.
4. Margin value = Emission Level – Limit value
5. " \* ": Fundamental frequency.
6. " # ": The radiated frequency is out of the restricted band.

**Below 1GHz Data:**

**802.11ac (VHT40)**

<b>CHANNEL</b>	TX Channel 110	<b>DETECTOR FUNCTION</b>	Quasi-Peak (QP)
<b>FREQUENCY RANGE</b>	9kHz ~ 1GHz		

**ANTENNA POLARITY & TEST DISTANCE: HORIZONTAL AT 3 M**

NO.	FREQ. (MHz)	EMISSION LEVEL (dBuV/m)	LIMIT (dBuV/m)	MARGIN (dB)	ANTENNA HEIGHT (m)	TABLE ANGLE (Degree)	RAW VALUE (dBuV)	CORRECTION FACTOR (dB/m)
1	41.61	31.5 QP	40.0	-8.5	1.15 H	347	40.5	-9.0
2	76.77	31.0 QP	40.0	-9.0	1.82 H	180	43.6	-12.6
3	113.78	32.0 QP	43.5	-11.5	1.12 H	180	43.1	-11.1
4	152.00	39.5 QP	43.5	-4.0	1.44 H	331	48.0	-8.5
5	224.10	38.3 QP	46.0	-7.7	1.24 H	331	50.4	-12.1
6	372.00	35.9 QP	46.0	-10.1	1.22 H	170	42.1	-6.2

**ANTENNA POLARITY & TEST DISTANCE: VERTICAL AT 3 M**

NO.	FREQ. (MHz)	EMISSION LEVEL (dBuV/m)	LIMIT (dBuV/m)	MARGIN (dB)	ANTENNA HEIGHT (m)	TABLE ANGLE (Degree)	RAW VALUE (dBuV)	CORRECTION FACTOR (dB/m)
1	47.85	36.0 QP	40.0	-4.0	1.26 V	180	44.8	-8.8
2	83.95	33.3 QP	40.0	-6.7	1.85 V	130	47.5	-14.2
3	185.62	39.7 QP	43.5	-3.8	1.95 V	301	50.7	-11.0
4	214.21	36.5 QP	43.5	-7.0	1.22 V	118	48.5	-12.0
5	510.16	42.5 QP	46.0	-3.5	1.65 V	272	45.0	-2.5
6	533.85	42.4 QP	46.0	-3.6	1.22 V	262	44.7	-2.3

**REMARKS:**

1. Emission Level(dBuV/m) = Raw Value(dBuV) + Correction Factor(dB/m)
2. Correction Factor(dB/m) = Antenna Factor(dB/m) + Cable Factor(dB) – Pre-Amplifier Factor(dB)
3. The other emission levels were very low against the limit.
4. Margin value = Emission Level – Limit value

## 4.2 Conducted Emission Measurement

### 4.2.1 Limits of Conducted Emission Measurement

Frequency (MHz)	Conducted Limit (dBuV)	
	Quasi-peak	Average
0.15 - 0.5	66 - 56	56 - 46
0.50 - 5.0	56	46
5.0 - 30.0	60	50

Note: 1. The lower limit shall apply at the transition frequencies.

2. The limit decreases in line with the logarithm of the frequency in the range of 0.15 to 0.50MHz.

### 4.2.2 Test Instruments

DESCRIPTION & MANUFACTURER	MODEL NO.	SERIAL NO.	CALIBRATED DATE	CALIBRATED UNTIL
Test Receiver R&S	ESCS 30	100375	May 09, 2016	May 08, 2017
Line-Impedance Stabilization Network (for EUT) SCHWARZBECK	NSLK-8127	8127-522	Aug. 31, 2016	Aug. 30, 2017
Line-Impedance Stabilization Network (for Peripheral ) R&S	ENV216	100072	June 13, 2016	June 12, 2017
RF Cable	5D-FB	COACAB-002	Mar. 04, 2016	Mar. 03, 2017
10 dB PAD Mini-Circuits	HAT-10+	CONATT-003	Sep. 13, 2016	Sep. 12, 2017
50 ohms Terminator	N/A	EMC-03	Sep. 29, 2016	Sep. 28, 2017
50 ohms Terminator	N/A	EMC-02	Sep. 29, 2016	Sep. 28, 2017
Software BVADT	BVADT_Cond_ V7.3.7.4	NA	NA	NA

**Note:**

1. The calibration interval of the above test instruments are 12 months and the calibrations are traceable to NML/ROC and NIST/USA.
2. The test was performed in Shielded Room No. C.
- 3 The VCCI Con C Registration No. is C-3611.
- 4 Tested Date:Nov. 16, 2016

#### 4.2.3 Test Procedure

- The EUT was placed 0.4 meters from the conducting wall of the shielded room with EUT being connected to the power mains through a line impedance stabilization network (LISN). Other support units were connected to the power mains through another LISN. The two LISNs provide 50 ohm/ 50uH of coupling impedance for the measuring instrument.
- Both lines of the power mains connected to the EUT were checked for maximum conducted interference.
- The frequency range from 150kHz to 30MHz was searched. Emission levels under (Limit - 20dB) was not recorded.

**NOTE:** All modes of operation were investigated and the worst-case emissions are reported.

#### 4.2.4 Deviation from Test Standard

No deviation.

#### 4.2.5 Test Setup

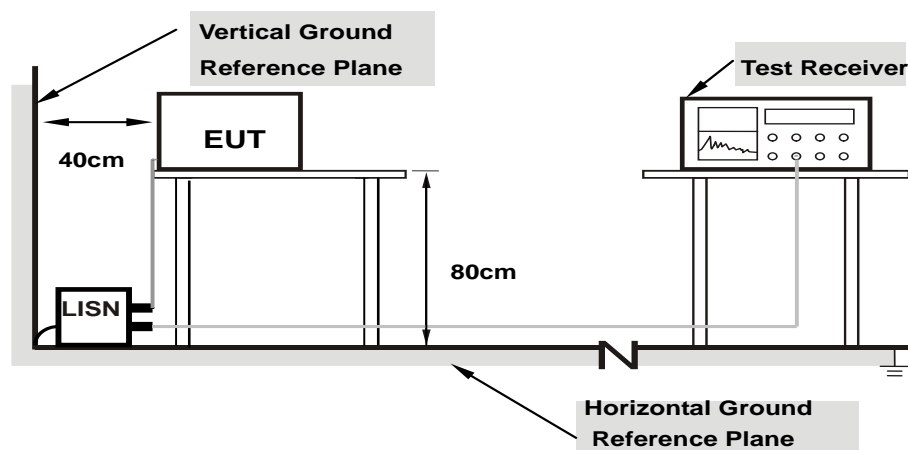

**Note: 1.Support units were connected to second LISN.**

For the actual test configuration, please refer to the attached file (Test Setup Photo).

#### 4.2.6 EUT Operating Condition

Same as 4.1.6.

#### 4.2.7 Test Results (Mode 1)

Phase	Line (L)	Detector Function	Quasi-Peak (QP) / Average (AV)
-------	----------	-------------------	--------------------------------

No	Freq. [MHz]	Corr.	Reading Value		Emission Level		Limit		Margin	
		Factor (dB)	[dB (uV)]		[dB (uV)]		[dB (uV)]		(dB)	
			Q.P.	AV.	Q.P.	AV.	Q.P.	AV.	Q.P.	AV.
1	0.17739	10.13	30.23	18.29	40.36	28.42	64.61	54.61	-24.25	-26.19
2	0.30238	10.11	33.23	26.61	43.34	36.72	60.18	50.18	-16.84	-13.46
3	0.33362	10.11	24.44	18.36	34.55	28.47	59.36	49.36	-24.81	-20.89
4	0.47855	10.11	13.29	5.88	23.40	15.99	56.36	46.36	-32.96	-30.37
5	6.39089	10.36	12.48	2.69	22.84	13.05	60.00	50.00	-37.16	-36.95
6	10.76976	10.46	11.46	7.28	21.92	17.74	60.00	50.00	-38.08	-32.26

#### REMARKS:

1. Q.P. and AV. are abbreviations of quasi-peak and average individually.
2. The emission levels of other frequencies were very low against the limit.
3. Margin value = Emission level - Limit value
4. Correction factor = Insertion loss + Cable loss
5. Emission Level = Correction Factor + Reading Value.

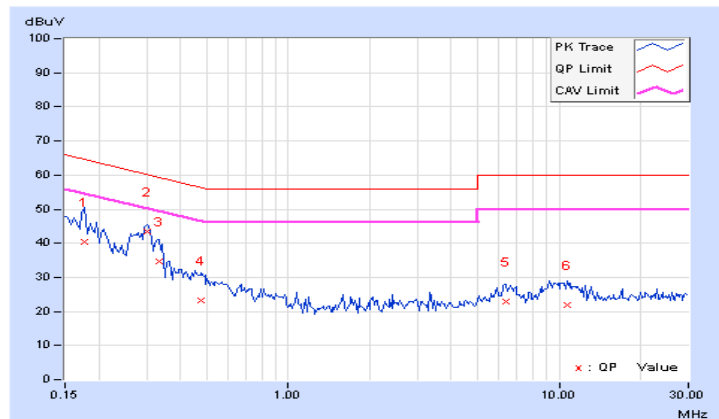

Phase	Neutral (N)	Detector Function	Quasi-Peak (QP) / Average (AV)
-------	-------------	-------------------	--------------------------------

No	Freq.	Corr.	Reading Value		Emission Level		Limit		Margin	
	[MHz]	Factor	[dB (uV)]		[dB (uV)]		[dB (uV)]		(dB)	
		(dB)	Q.P.	AV.	Q.P.	AV.	Q.P.	AV.	Q.P.	AV.
1	0.16565	10.15	31.96	17.93	42.11	28.08	65.18	55.18	-23.07	-27.10
<b>2</b>	<b>0.29849</b>	<b>10.08</b>	<b>34.78</b>	<b>27.55</b>	<b>44.86</b>	<b>37.63</b>	<b>60.28</b>	<b>50.28</b>	<b>-15.42</b>	<b>-12.65</b>
3	0.56033	10.12	17.83	12.66	27.95	22.78	56.00	46.00	-28.05	-23.22
4	0.83366	10.18	13.75	8.66	23.93	18.84	56.00	46.00	-32.07	-27.16
5	9.61723	10.47	15.33	9.69	25.80	20.16	60.00	50.00	-34.20	-29.84
6	21.45715	10.89	4.82	3.03	15.71	13.92	60.00	50.00	-44.29	-36.08

#### REMARKS:

1. Q.P. and AV. are abbreviations of quasi-peak and average individually.
2. The emission levels of other frequencies were very low against the limit.
3. Margin value = Emission level - Limit value
4. Correction factor = Insertion loss + Cable loss
5. Emission Level = Correction Factor + Reading Value.

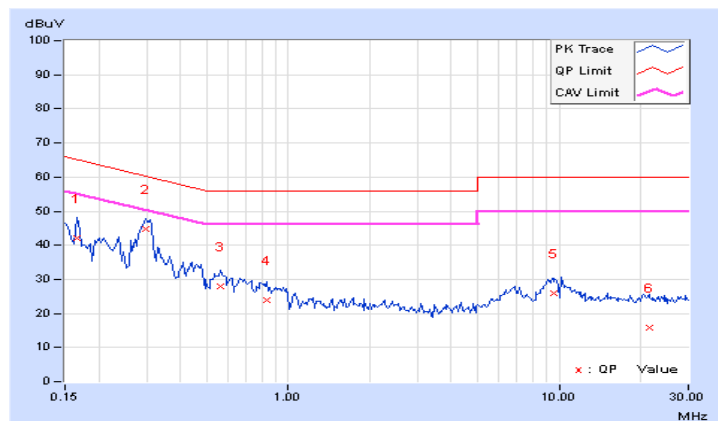

#### 4.2.8 Test Results (Mode 2)

Phase	Line (L)	Detector Function	Quasi-Peak (QP) / Average (AV)
-------	----------	-------------------	--------------------------------

No	Freq. [MHz]	Corr. Factor	Reading Value [dB (uV)]		Emission Level [dB (uV)]		Limit [dB (uV)]		Margin (dB)	
		(dB)	Q.P.	AV.	Q.P.	AV.	Q.P.	AV.	Q.P.	AV.
	1	0.16569	10.13	31.29	15.22	41.42	25.35	65.17	55.17	-23.75
2	0.21255	10.12	27.66	16.45	37.78	26.57	63.11	53.11	-25.33	-26.54
3	0.48208	10.11	21.33	15.66	31.44	25.77	56.30	46.30	-24.86	-20.53
4	7.00001	10.37	23.53	18.99	33.90	29.36	60.00	50.00	-26.10	-20.64
5	13.51175	10.57	18.22	12.95	28.79	23.52	60.00	50.00	-31.21	-26.48
6	29.69928	11.16	19.22	14.33	30.38	25.49	60.00	50.00	-29.62	-24.51

#### REMARKS:

1. Q.P. and AV. are abbreviations of quasi-peak and average individually.
2. The emission levels of other frequencies were very low against the limit.
3. Margin value = Emission level - Limit value
4. Correction factor = Insertion loss + Cable loss
5. Emission Level = Correction Factor + Reading Value.

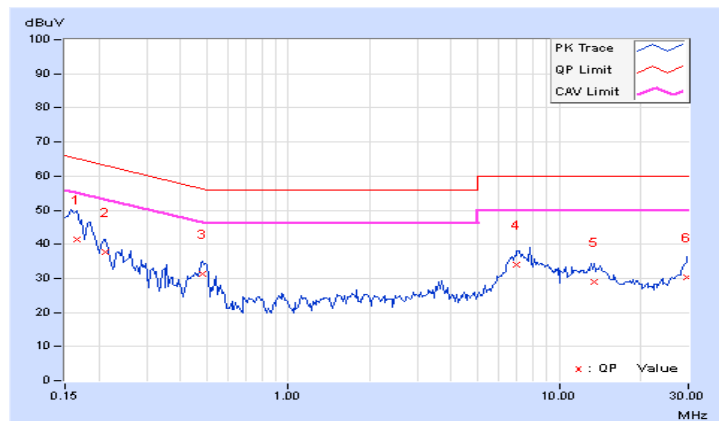



Phase	Neutral (N)	Detector Function	Quasi-Peak (QP) / Average (AV)
-------	-------------	-------------------	--------------------------------

No	Freq. [MHz]	Corr. Factor	Reading Value [dB (uV)]		Emission Level [dB (uV)]		Limit [dB (uV)]		Margin (dB)	
		(dB)	Q.P.	AV.	Q.P.	AV.	Q.P.	AV.	Q.P.	AV.
	1	0.16175	10.16	36.89	25.47	47.05	35.63	65.37	55.37	-18.32
2	0.29066	10.08	22.36	17.69	32.44	27.77	60.51	50.51	-28.07	-22.74
3	0.48205	10.11	22.69	18.92	32.80	29.03	56.30	46.30	-23.50	-17.27
4	1.48439	10.19	10.13	6.29	20.32	16.48	56.00	46.00	-35.68	-29.52
5	6.97269	10.40	23.66	19.16	34.06	29.56	60.00	50.00	-25.94	-20.44
6	13.58208	10.62	17.19	11.86	27.81	22.48	60.00	50.00	-32.19	-27.52

**REMARKS:**

1. Q.P. and AV. are abbreviations of quasi-peak and average individually.
2. The emission levels of other frequencies were very low against the limit.
3. Margin value = Emission level - Limit value
4. Correction factor = Insertion loss + Cable loss
5. Emission Level = Correction Factor + Reading Value.

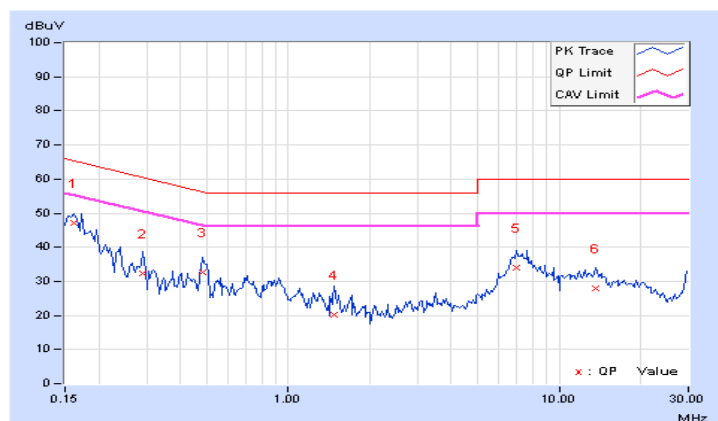

### 4.3 Transmit Power Measurement

#### 4.3.1 Limits of Transmit Power Measurement

Operation Band	EUT Category		Limit
U-NII-1		Outdoor Access Point	1 Watt (30 dBm) (Max. e.i.r.p $\leq$ 125mW(21 dBm) at any elevation angle above 30 degrees as measured from the horizon)
		Fixed point-to-point Access Point	1 Watt (30 dBm)
		Indoor Access Point	1 Watt (30 dBm)
		Mobile and Portable client device	250mW (24 dBm)
U-NII-2A	√		250mW (24 dBm) or 11 dBm+10 log B*
U-NII-2C	√		250mW (24 dBm) or 11 dBm+10 log B*
U-NII-3			1 Watt (30 dBm)

\*B is the 26 dB emission bandwidth in megahertz

Per KDB 662911 Method of conducted output power measurement on IEEE 802.11 devices,

Array Gain = 0 dB (i.e., no array gain) for  $N_{ANT} \leq 4$ ;

Array Gain = 0 dB (i.e., no array gain) for channel widths  $\geq 40$  MHz for any  $N_{ANT}$ ;

Array Gain =  $5 \log(N_{ANT}/N_{SS})$  dB or 3 dB, whichever is less for 20-MHz channel widths with  $N_{ANT} \geq 5$ .

For power measurements on all other devices: Array Gain =  $10 \log(N_{ANT}/N_{SS})$  dB.

#### 4.3.2 Test Setup

##### FOR POWER OUTPUT MEASUREMENT

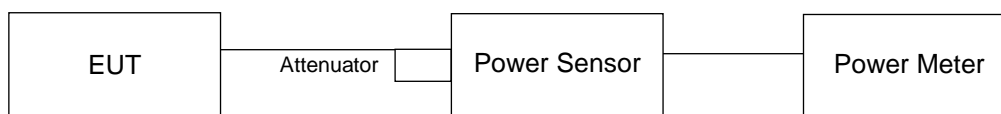

##### FOR 26dB OCCUPIED BANDWIDTH

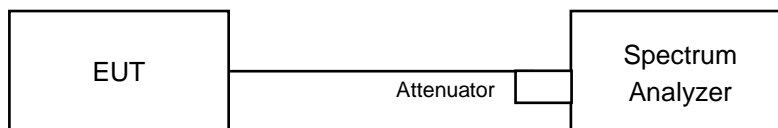

#### 4.3.3 Test Instruments

Refer to section 4.1.2 to get information of above instrument.

#### 4.3.4 Test Procedure

##### For Average Power Measurement

Method PM is used to perform output power measurement, trigger and gating function of wide band power meter is enabled to measure max output power of TX on burst. Duty factor is not added to measured value.

##### FOR 26dB OCCUPIED BANDWIDTH

1. Set RBW = approximately 1% of the emission bandwidth.
2. Set the VBW > RBW.
3. Detector = Peak.
4. Trace mode = max hold.
5. Measure the maximum width of the emission that is 26 dB down from the peak of the emission. Compare this with the RBW setting of the analyzer. Readjust RBW and repeat measurement as needed until the RBW/EBW ratio is approximately 1%.

#### 4.3.5 Deviation from Test Standard

No deviation.

#### 4.3.6 EUT Operating Condition

The software provided by client to enable the EUT under transmission condition continuously at lowest, middle and highest channel frequencies individually.

#### 4.3.7 Test Result

#### CDD Mode

#### 802.11a

#### Power Output:

Chan.	Chan. Freq. (MHz)	Maximum Conducted Power (dBm)			Total Power (mW)	Total Power (dBm)	Limit (dBm)	Pass / Fail
		Chain 0	Chain 1	Chain 2				
52	5260	18.86	18.76	19.05	232.428	23.66	24	Pass
60	5300	18.85	18.79	19.08	233.329	23.68	24	Pass
64	5320	18.87	18.81	19.01	232.739	23.67	24	Pass
100	5500	18.82	18.99	19.08	236.368	23.74	24	Pass
116	5580	18.73	19.21	18.98	237.081	23.75	24	Pass
140	5700	18.79	19.19	18.67	232.289	23.66	24	Pass

#### 26dB OCCUPIED BANDWIDTH

Channel	Frequency (MHz)	26dBc Bandwidth (MHz)		
		Chain 0	Chain 1	Chain 2
52	5260	20.55	20.42	20.18
60	5300	20.72	20.46	20.44
64	5320	20.80	20.45	20.54
100	5500	20.53	20.49	20.33
120	5600	20.48	20.48	20.39
140	5700	20.45	20.88	20.42

**Note: For U-NII-2A, U-NII-2C Band output power limitation is determined based on 26dBc bandwidth**

Power Limit = 11dBm + 10logB < U-NII-2A, U-NII-2C >			
Channel Number	Freq.(MHz)	Min. B(MHz)	Determined Conducted Limit (dBm)
52	5260	20.18	24.04 > 24
60	5300	20.44	24.1 > 24
64	5320	20.45	24.1 > 24
100	5500	20.33	24.08 > 24
120	5600	20.39	24.09 > 24
140	5700	20.42	24.1 > 24

## Beamforming Mode

### 802.11ac (VHT20)

Chan.	Chan. Freq. (MHz)	Maximum Conducted Power (dBm)			Total Power (mW)	Total Power (dBm)	Limit (dBm)	Pass / Fail
		Chain 0	Chain 1	Chain 2				
52	5260	18.82	18.79	19.17	234.495	23.70	24	Pass
60	5300	18.84	18.76	19.21	235.09	23.71	24	Pass
64	5320	18.88	18.78	19.15	235.001	23.71	24	Pass
100	5500	18.65	18.96	19.06	232.525	23.66	24	Pass
116	5580	18.76	19.17	18.92	235.749	23.72	24	Pass
140	5700	18.88	19.16	18.62	232.46	23.66	24	Pass

### 26dB OCCUPIED BANDWIDTH

Channel	Frequency (MHz)	26dBc Bandwidth (MHz)		
		Chain 0	Chain 1	Chain 2
52	5260	22.25	20.49	21.40
60	5300	22.07	20.76	20.80
64	5320	21.17	20.74	20.73
100	5500	20.84	20.69	20.68
120	5600	20.90	20.76	20.94
140	5700	22.24	21.92	20.58

**Note: For U-NII-2A, U-NII-2C Band output power limitation is determined based on 26dBc bandwidth**

Power Limit = 11dBm + 10logB < U-NII-2A, U-NII-2C >			
Channel Number	Freq.(MHz)	Min. B(MHz)	Determined Conducted Limit (dBm)
52	5260	20.49	24.11 > 24
60	5300	20.76	24.17 > 24
64	5320	20.73	24.16 > 24
100	5500	20.68	24.15 > 24
120	5600	20.76	24.17 > 24
140	5700	20.58	24.13 > 24

**802.11ac (VHT40)**

Chan.	Chan. Freq. (MHz)	Maximum Conducted Power (dBm)			Total Power (mW)	Total Power (dBm)	Limit (dBm)	Pass / Fail
		Chain 0	Chain 1	Chain 2				
54	5270	18.71	18.61	19.26	231.246	23.64	24	Pass
62	5310	18.26	18.24	18.73	208.314	23.19	24	Pass
102	5510	17.40	17.77	17.67	173.274	22.39	24	Pass
110	5550	18.79	19.39	19.21	245.947	23.91	24	Pass
134	5670	18.90	19.33	18.79	239.012	23.78	24	Pass

**26dB OCCUPIED BANDWIDTH**

Channel	Frequency (MHz)	26dBc Bandwidth (MHz)		
		Chain 0	Chain 1	Chain 2
54	5270	43.25	42.24	41.19
62	5310	41.32	41.30	40.76
102	5510	41.49	41.36	41.27
118	5590	41.75	41.18	41.85
134	5670	53.39	60.08	45.93

**Note: For U-NII-2A, U-NII-2C Band output power limitation is determined based on 26dBc bandwidth**

Power Limit = 11dBm + 10logB < U-NII-2A, U-NII-2C >			
Channel Number	Freq.(MHz)	Min. B(MHz)	Determined Conducted Limit (dBm)
54	5270	41.19	27.14 > 24
62	5310	40.76	27.1 > 24
102	5510	41.27	27.15 > 24
118	5590	41.18	27.14 > 24
134	5670	45.93	27.62 > 24

### 802.11ac (VHT80)

Chan.	Chan. Freq. (MHz)	Maximum Conducted Power (dBm)			Total Power (mW)	Total Power (dBm)	Limit (dBm)	Pass / Fail
		Chain 0	Chain 1	Chain 2				
58	5290	17.19	17.73	18.36	180.202	22.56	24	Pass
106	5530	17.46	18.43	18.28	192.68	22.85	24	Pass
122	5610	18.52	19.33	18.94	235.168	23.71	24	Pass

### 26dB OCCUPIED BANDWIDTH

Channel	Frequency (MHz)	26dBc Bandwidth (MHz)		
		Chain 0	Chain 1	Chain 2
58	5290	83.22	82.70	82.18
106	5530	82.77	82.54	81.97
122	5610	83.76	86.99	83.02

**Note: For U-NII-2A, U-NII-2C Band output power limitation is determined based on 26dBc bandwidth**

Power Limit = 11dBm + 10logB < U-NII-2A, U-NII-2C >			
Channel Number	Freq.(MHz)	Min. B(MHz)	Determined Conducted Limit (dBm)
58	5290	82.18	30.14 > 24
106	5530	81.97	30.13 > 24
122	5610	83.02	30.19 > 24

### Spectrum Plot of Worst Value

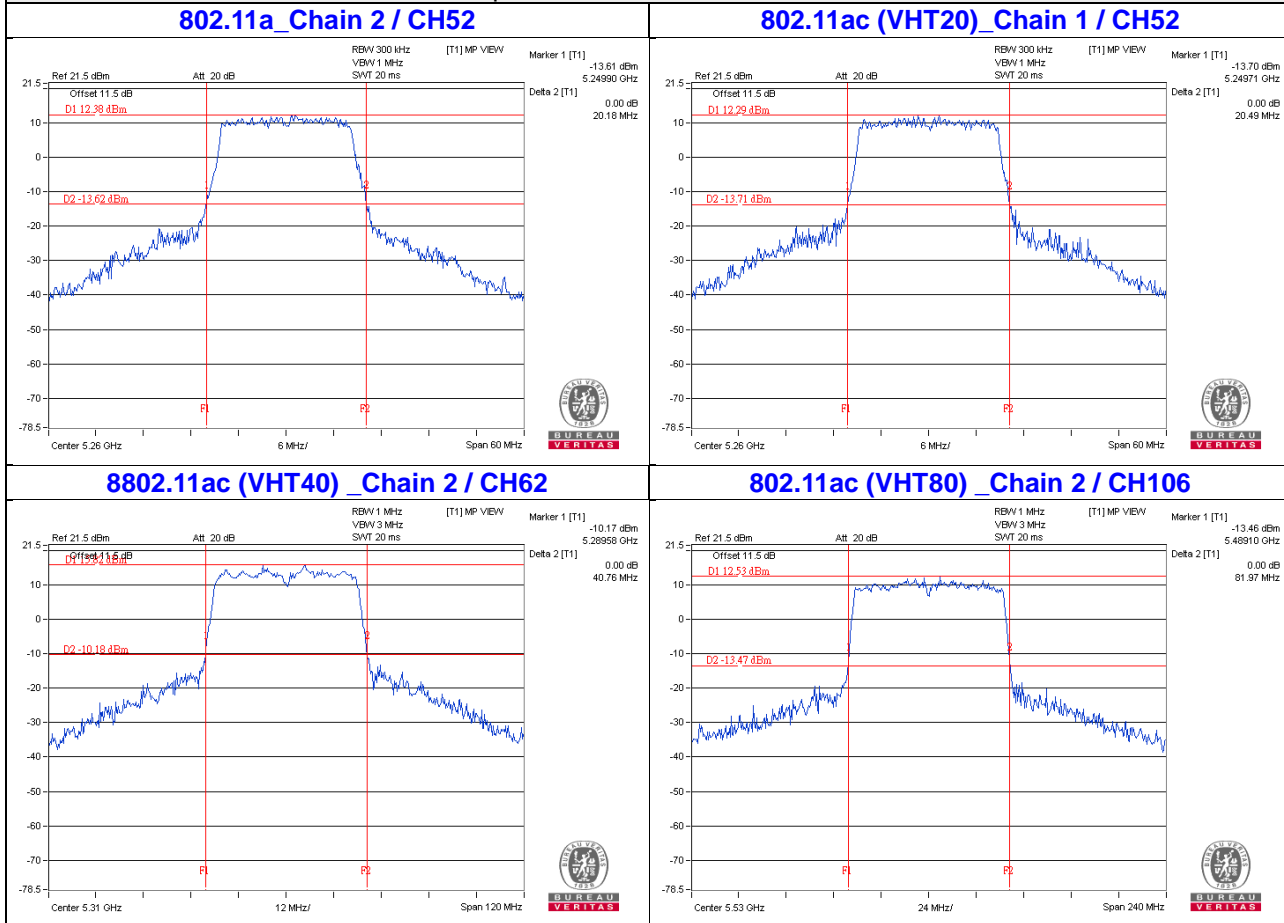



## 4.4 Occupied Bandwidth Measurement

### 4.4.1 Test Setup

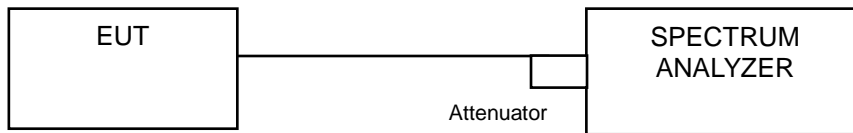

### 4.4.2 Test Instruments

Refer to section 4.1.2 to get information of above instrument.

### 4.4.3 Test Procedure

The transmitter output was connected to the spectrum analyzer through an attenuator. The bandwidth of the fundamental frequency was measured by spectrum analyzer with resolution bandwidth in the range of 1% to 5% of the anticipated emission bandwidth, and a video bandwidth at least 3x the resolution bandwidth and set the detector to SAMPLE. The width of a frequency band such that, below the lower and above the upper frequency limits, the mean powers emitted are each equal to a specified percentage 0.5 %of the total mean power of a given emission.

#### 4.4.4 Test Results

##### CDD Mode

##### 802.11a

Channel	Channel Frequency (MHz)	Occupied Bandwidth (MHz)		
		CHAIN 0	CHAIN 1	CHAIN 2
52	5260	16.80	16.68	16.92
60	5300	16.80	16.80	16.68
64	5320	16.80	16.80	16.80
100	5500	16.92	16.68	16.80
116	5580	16.92	16.80	16.68
140	5700	16.92	16.92	16.80

##### Beamforming Mode

##### 802.11ac (VHT20)

Channel	Channel Frequency (MHz)	Occupied Bandwidth (MHz)		
		CHAIN 0	CHAIN 1	CHAIN 2
52	5260	17.88	17.88	17.88
60	5300	17.88	17.88	17.88
64	5320	17.88	17.88	17.88
100	5500	17.88	17.76	17.76
116	5580	18.00	17.88	17.76
140	5700	17.88	17.88	17.76

##### 802.11ac (VHT40)

Channel	Channel Frequency (MHz)	Occupied Bandwidth (MHz)		
		CHAIN 0	CHAIN 1	CHAIN 2
54	5270	36.72	36.72	36.48
62	5310	36.72	36.72	36.72
102	5510	36.72	36.72	36.96
110	5550	36.72	36.72	36.72
134	5670	36.72	36.72	36.72

##### 802.11ac (VHT80)

Channel	Channel Frequency (MHz)	Occupied Bandwidth (MHz)		
		CHAIN 0	CHAIN 1	CHAIN 2
58	5290	76.32	76.32	75.36
106	5530	75.84	76.32	76.32
122	5610	76.32	76.32	76.32

### Spectrum Plot of Worst Value

**802.11a\_Chain0 / CH100**

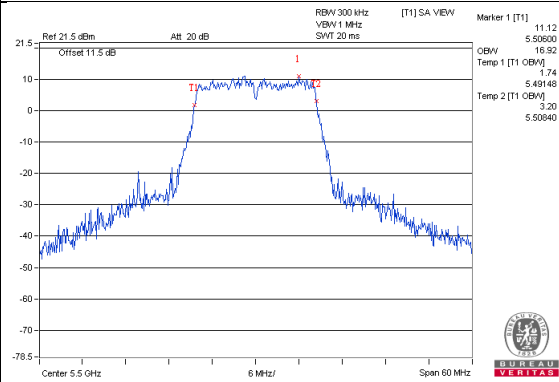

**802.11ac (VHT20)\_Chain0 / CH116**

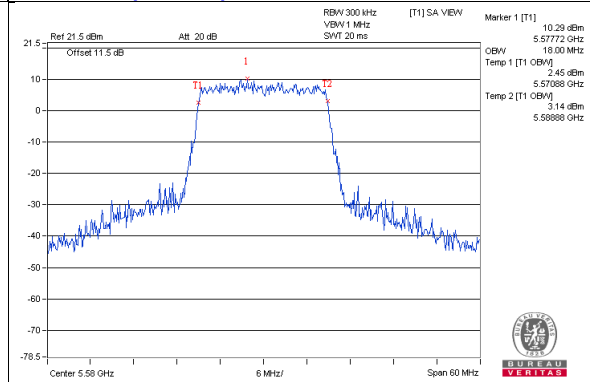

**802.11ac (VHT40)\_Chain2 / CH102**

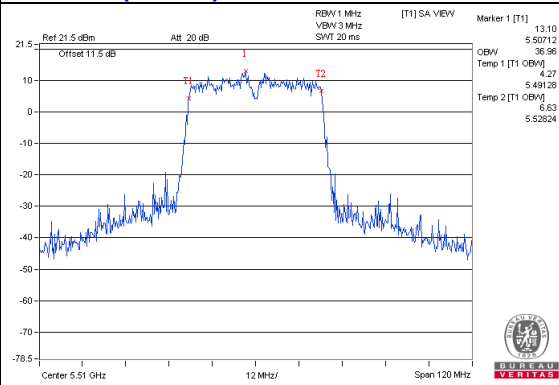

**802.11ac (VHT80)\_Chain0 / CH58**

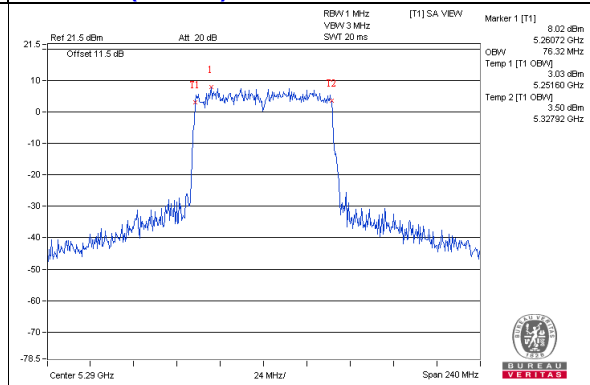

## 4.5 Peak Power Spectral Density Measurement

### 4.5.1 Limits of Peak Power Spectral Density Measurement

Operation Band	EUT Category		Limit
U-NII-1		Outdoor Access Point	17dBm/ MHz
		Fixed point-to-point Access Point	
		Indoor Access Point	
		Mobile and Portable client device	11dBm/ MHz
U-NII-2A		√	11dBm/ MHz
U-NII-2C		√	11dBm/ MHz
U-NII-3			30dBm/ 500kHz

### 4.5.2 Test Setup

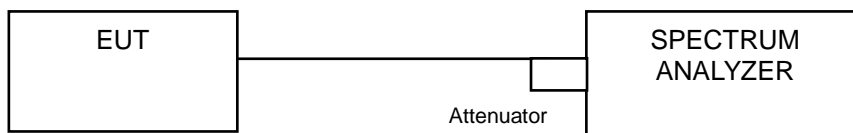

### 4.5.3 Test Instruments

Refer to section 4.1.2 to get information of above instrument.

### 4.5.4 Test Procedure

#### 802.11a, 802.11ac (VHT20), 802.11ac (VHT40)

Using method SA-1

1. Set span to encompass the entire emission bandwidth (EBW) of the signal.
2. Set RBW = 1 MHz, Set VBW  $\geq$  3 MHz, Detector = RMS
3. Sweep time = auto, trigger set to "free run".
4. Trace average at least 100 traces in power averaging mode.
5. Record the max value

#### 802.11ac (VHT80)

Using method SA-2

1. Set span to encompass the entire emission bandwidth (EBW) of the signal.
2. Set RBW = 1 MHz, Set VBW  $\geq$  3 MHz, Detector = RMS
3. Sweep time = auto, trigger set to "free run".
4. Trace average at least 100 traces in power averaging mode.
5. Record the max value and add  $10 \log(1/\text{duty cycle})$

### 4.5.5 Deviation from Test Standard

No deviation.

### 4.5.6 EUT Operating Condition

Same as Item 4.3.6.

#### 4.5.7 Test Results

##### CDD Mode

##### 802.11a

Chan.	Chan. Freq. (MHz)	PSD (dBm/MHz)			Total Power Density (dBm/MHz)	MAX. Limit (dBm/MHz)	Pass / Fail
		Chain 0	Chain 1	Chain 2			
52	5260	6.50	4.93	6.46	10.79	11.00	Pass
60	5300	5.76	5.28	6.72	10.73	11.00	Pass
64	5320	5.70	5.68	6.70	10.82	11.00	Pass
100	5500	6.17	5.83	6.02	10.78	11.00	Pass
120	5600	6.55	6.47	5.54	10.98	11.00	Pass
140	5700	6.28	6.09	5.40	10.71	11.00	Pass

- Note:** 1. Method a) of power density measurement of KDB 662911 is using for calculating total power density. Total power density is summing entire spectra across corresponding frequency bins on the various outputs by computer.
2. For UNII-2A: Directional gain = 5.95dBi < 6dBi, so the power density limit shall not be reduced.
3. For UNII-2C: Directional gain = 5.98dBi < 6dBi, so the power density limit shall not be reduced.

##### Beamforming Mode

##### 802.11ac (VHT20)

Chan.	Chan. Freq. (MHz)	PSD (dBm/MHz)			Total Power Density (dBm/MHz)	MAX. Limit (dBm/MHz)	Pass / Fail
		Chain 0	Chain 1	Chain 2			
52	5260	5.62	6.18	6.30	10.81	11.00	Pass
60	5300	5.17	6.05	7.17	10.98	11.00	Pass
64	5320	5.11	5.51	7.25	10.83	11.00	Pass
100	5500	5.87	6.03	6.67	10.98	11.00	Pass
120	5600	5.73	6.54	6.23	10.95	11.00	Pass
140	5700	5.99	6.59	5.80	10.91	11.00	Pass

- Note:** 1. Method a) of power density measurement of KDB 662911 is using for calculating total power density. Total power density is summing entire spectra across corresponding frequency bins on the various outputs by computer.
2. For UNII-2A: Directional gain = 5.95dBi < 6dBi, so the power density limit shall not be reduced.
3. For UNII-2C: Directional gain = 5.98dBi < 6dBi, so the power density limit shall not be reduced.

### 802.11ac (VHT40)

Chan.	Chan. Freq. (MHz)	PSD (dBm/MHz)			Total Power Density (dBm/MHz)	MAX. Limit (dBm/MHz)	Pass / Fail
		Chain 0	Chain 1	Chain 2			
54	5270	3.11	2.87	4.21	8.21	11.00	Pass
62	5310	2.43	2.51	4.09	7.85	11.00	Pass
102	5510	2.11	2.40	1.10	6.68	11.00	Pass
118	5590	2.99	3.56	4.19	8.38	11.00	Pass
134	5670	3.47	3.79	2.36	8.02	11.00	Pass

- Note:**
- Method a) of power density measurement of KDB 662911 is using for calculating total power density. Total power density is summing entire spectra across corresponding frequency bins on the various outputs by computer.
  - For UNII-2A: Directional gain = 5.95dBi < 6dBi, so the power density limit shall not be reduced.
  - For UNII-2C: Directional gain = 5.98dBi < 6dBi, so the power density limit shall not be reduced.

### 802.11ac (VHT80)

Chan.	Chan. Freq. (MHz)	PSD W/O Duty Factor (dBm/MHz)			Duty Factor (dB)	Total PSD With Duty Factor (dBm/MHz)	MAX. Limit (dBm/MHz)	Pass / Fail
		Chain 0	Chain 1	Chain 2				
58	5290	-1.64	-0.94	-0.43	0.19	3.99	11.00	Pass
106	5530	-1.33	-0.23	0.00	0.19	4.48	11.00	Pass
122	5610	-0.14	0.43	0.70	0.19	5.31	11.00	Pass

- Note:**
- Method a) of power density measurement of KDB 662911 is using for calculating total power density. Total power density is summing entire spectra across corresponding frequency bins on the various outputs by computer.
  - For UNII-2A: Directional gain = 5.95dBi < 6dBi, so the power density limit shall not be reduced.
  - For UNII-2C: Directional gain = 5.98dBi < 6dBi, so the power density limit shall not be reduced.
  - Refer to section 3.3 for duty cycle spectrum plot

Spectrum Plot of Worst Value

802.11a\_Chain 2 / CH60

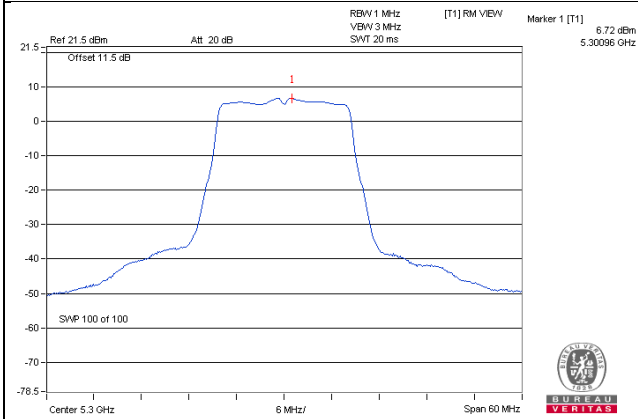

802.11ac (VHT20)\_Chain 2 / CH64

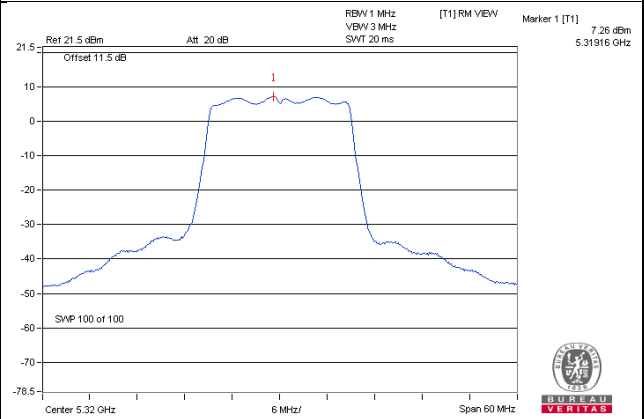

802.11ac (VHT40)\_Chain 2 / CH54

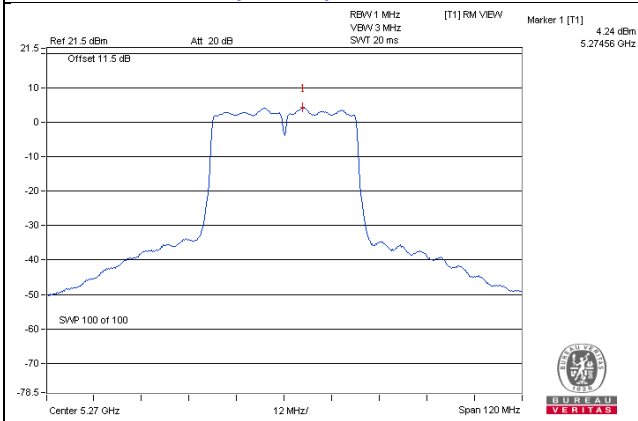

802.11ac (VHT80)\_Chain 2 / CH122

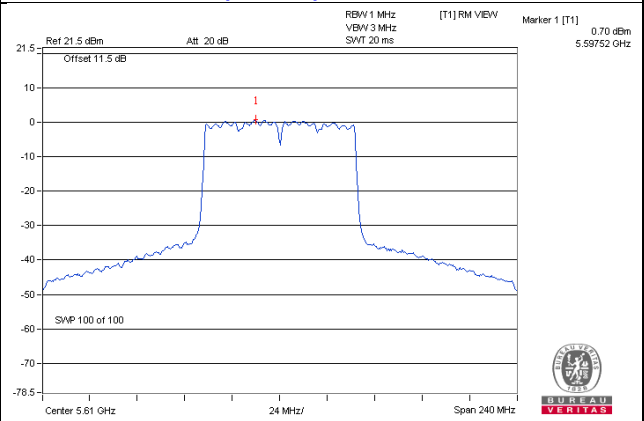

## 4.6 Frequency Stability Measurement

### 4.6.1 Limits of Frequency Stability Measurement

The frequency of the carrier signal shall be maintained within band of operation

### 4.6.2 Test Setup

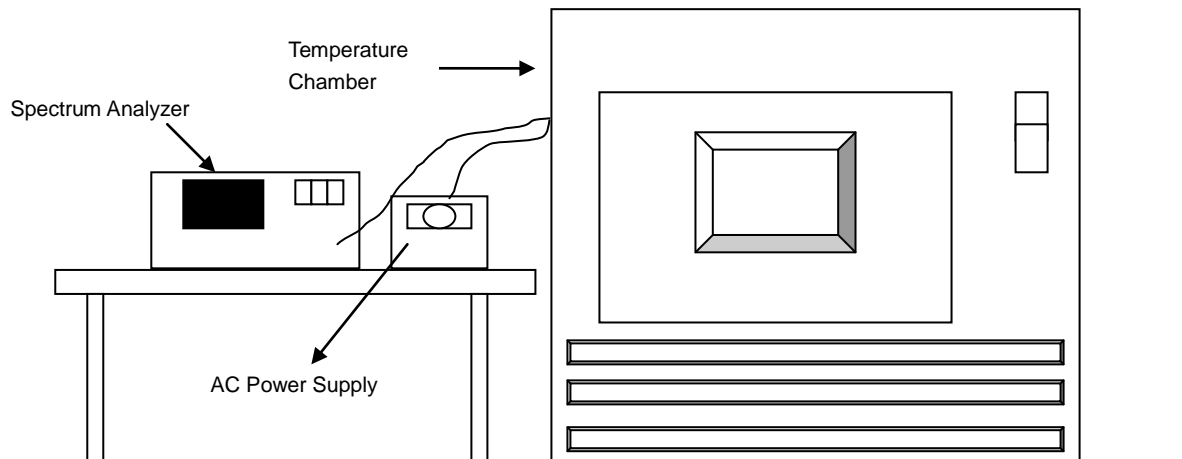

### 4.6.3 Test Instruments

Refer to section 4.1.2 to get information of above instrument.

### 4.6.4 Test Procedure

- The EUT was placed inside the environmental test chamber and powered by nominal AC voltage.
- Turn the EUT on and couple its output to a spectrum analyzer.
- Turn the EUT off and set the chamber to the highest temperature specified.
- Allow sufficient time (approximately 30 min) for the temperature of the chamber to stabilize, turn the EUT on and measure the operating frequency after 2, 5, and 10 Minutes.
- Repeat step 2 and 3 with the temperature chamber set to the lowest temperature.
- The test chamber was allowed to stabilize at +20 degree C for a minimum of 30 Minutes. The supply voltage was then adjusted on the EUT from 85% to 115% and the frequency record.

### 4.6.5 Deviation from Test Standard

No deviation.

### 4.6.6 EUT Operating Condition

Set the EUT transmit at un-modulation mode to test frequency stability.



#### 4.6.7 Test Results

Frequency Stability Versus Temp.									
Operating Frequency: 5260 MHz									
TEMP. (°C)	Power Supply (Vac)	0 Minute		2 Minute		5 Minute		10 Minute	
		Measured Frequency (MHz)	Pass/Fail	Measured Frequency (MHz)	Pass/Fail	Measured Frequency (MHz)	Pass/Fail	Measured Frequency (MHz)	Pass/Fail
50	120	5260.0116	Pass	5260.0099	Pass	5260.0114	Pass	5260.0111	Pass
40	120	5260.0248	Pass	5260.0241	Pass	5260.021	Pass	5260.0249	Pass
30	120	5260.0254	Pass	5260.0247	Pass	5260.0228	Pass	5260.0261	Pass
20	120	5260.0138	Pass	5260.0122	Pass	5260.0151	Pass	5260.0144	Pass
10	120	5259.977	Pass	5259.9798	Pass	5259.9756	Pass	5259.9786	Pass
0	120	5259.9886	Pass	5259.9923	Pass	5259.9886	Pass	5259.9883	Pass
-10	120	5259.9783	Pass	5259.9771	Pass	5259.9787	Pass	5259.9807	Pass
-20	120	5259.981	Pass	5259.9855	Pass	5259.9842	Pass	5259.9856	Pass
-30	120	5259.9917	Pass	5259.9914	Pass	5259.9914	Pass	5259.9874	Pass

Frequency Stability Versus Voltage									
Operating Frequency: 5260 MHz									
TEMP. (°C)	Power Supply (Vac)	0 Minute		2 Minute		5 Minute		10 Minute	
		Measured Frequency (MHz)	Pass/Fail	Measured Frequency (MHz)	Pass/Fail	Measured Frequency (MHz)	Pass/Fail	Measured Frequency (MHz)	Pass/Fail
20	138	5260.0137	Pass	5260.0123	Pass	5260.0158	Pass	5260.0146	Pass
	120	5260.0138	Pass	5260.0122	Pass	5260.0151	Pass	5260.0144	Pass
	102	5260.0148	Pass	5260.0112	Pass	5260.0142	Pass	5260.0152	Pass

## 5 Pictures of Test Arrangements

Please refer to the attached file (Test Setup Photo).

## Appendix – Information on the Testing Laboratories

We, Bureau Veritas Consumer Products Services (H.K.) Ltd., Taoyuan Branch, were founded in 1988 to provide our best service in EMC, Radio, Telecom and Safety consultation. Our laboratories are accredited and approved according to ISO/IEC 17025.

If you have any comments, please feel free to contact us at the following:

**Linko EMC/RF Lab**

Tel: 886-2-26052180

Fax: 886-2-26051924

**Hsin Chu EMC/RF/Telecom Lab**

Tel: 886-3-6668565

Fax: 886-3-6668323

**Hwa Ya EMC/RF/Safety Lab**

Tel: 886-3-3183232

Fax: 886-3-3270892

**Email:** [service.adt@tw.bureauveritas.com](mailto:service.adt@tw.bureauveritas.com)

**Web Site:** [www.bureauveritas-adt.com](http://www.bureauveritas-adt.com)

The address and road map of all our labs can be found in our web site also.

--- END ---