

FCC Test Report

Report No.: RF160621C27-1

FCC ID: PY316200341

Test Model: RBR50

Series Model: RBS50

Received Date: Jun. 20, 2016

Test Date: Jun. 20 ~ Aug. 19, 2016

Issued Date: Aug. 19, 2016

Applicant: NETGEAR, INC.

Address: 350 East Plumeria Drive San Jose, CA 95134

Issued By: Bureau Veritas Consumer Products Services (H.K.) Ltd., Taoyuan Branch

Lab Address: No. 47-2, 14th Ling, Chia Pau Vil., Lin Kou Dist., New Taipei City, Taiwan (R.O.C.)

Test Location: No. 19, Hwa Ya 2nd Rd., Wen Hwa Vil., Kwei Shan Dist., Taoyuan City 33383, TAIWAN (R.O.C.)



This report is for your exclusive use. Any copying or replication of this report to or for any other person or entity, or use of our name or trademark, is permitted only with our prior written permission. This report sets forth our findings solely with respect to the test samples identified herein. The results set forth in this report are not indicative or representative of the quality or characteristics of the lot from which a test sample was taken or any similar or identical product unless specifically and expressly noted. Our report includes all of the tests requested by you and the results thereof based upon the information that you provided to us. You have 60 days from date of issuance of this report to notify us of any material error or omission caused by our negligence, provided, however, that such notice shall be in writing and shall specifically address the issue you wish to raise. A failure to raise such issue within the prescribed time shall constitute your unqualified acceptance of the completeness of this report, the tests conducted and the correctness of the report contents. Unless specific mention, the uncertainty of measurement has been explicitly taken into account to declare the compliance or non-compliance to the specification. The report must not be used by the client to claim product certification, approval, or endorsement by TAF or any government agencies.

Table of Contents

Release Control Record	4
1 Certificate of Conformity	5
2 Summary of Test Results	6
2.1 Measurement Uncertainty.....	6
2.2 Modification Record.....	6
3 General Information	7
3.1 General Description of EUT.....	7
3.2 Description of Test Modes.....	10
3.2.1 Test Mode Applicability and Tested Channel Detail.....	11
3.3 Duty Cycle of Test Signal.....	13
3.4 Description of Support Units.....	18
3.4.1 Configuration of System under Test.....	18
3.5 General Description of Applied Standard.....	18
4 Test Types and Results	19
4.1 Radiated Emission and Bandedge Measurement.....	19
4.1.1 Limits of Radiated Emission and Bandedge Measurement.....	19
4.1.2 Test Instruments.....	20
4.1.3 Test Procedure.....	21
4.1.4 Deviation from Test Standard.....	21
4.1.5 Test Setup.....	22
4.1.6 EUT Operating Conditions.....	22
4.1.7 Test Results.....	23
4.2 Conducted Emission Measurement.....	42
4.2.1 Limits of Conducted Emission Measurement.....	42
4.2.2 Test Instruments.....	42
4.2.3 Test Procedure.....	43
4.2.4 Deviation from Test Standard.....	43
4.2.5 Test Setup.....	43
4.2.6 EUT Operating Conditions.....	43
4.2.7 Test Results.....	44
4.3 Transmit Power Measurement.....	48
4.3.1 Limits of Transmit Power Measurement.....	48
4.3.2 Test Setup.....	48
4.3.3 Test Instruments.....	48
4.3.4 Test Procedure.....	49
4.3.5 Deviation from Test Standard.....	49
4.3.6 EUT Operating Conditions.....	49
4.3.7 Test Result.....	50
4.4 Peak Power Spectral Density Measurement.....	69
4.4.1 Limits of Peak Power Spectral Density Measurement.....	69
4.4.2 Test Setup.....	69
4.4.3 Test Instruments.....	69
4.4.4 Test Procedure.....	70
4.4.5 Deviation from Test Standard.....	70
4.4.6 EUT Operating Condition.....	70
4.4.7 Test Results.....	71
4.5 Frequency Stability.....	84
4.5.1 Limits of Frequency Stability Measurement.....	84
4.5.2 Test Setup.....	84
4.5.3 Test Instruments.....	84
4.5.4 Test Procedure.....	84
4.5.5 Deviation from Test Standard.....	84
4.5.6 EUT Operating Condition.....	84

4.5.7 Test Results	85
4.6 6dB Bandwidth Measurement.....	86
4.6.1 Limits of 6dB Bandwidth Measurement.....	86
4.6.2 Test Setup.....	86
4.6.3 Test Instruments	86
4.6.4 Test Procedure	86
4.6.5 Deviation from Test Standard	86
4.6.6 EUT Operating Condition	86
4.6.7 Test Results	87
5 Pictures of Test Arrangements.....	91
Annex A - Radiated Out of Band Emission (OOBE) Measurement (For U-NII-3 band)	92
Appendix – Information on the Testing Laboratories	95

Release Control Record

Issue No.	Description	Date Issued
RF160621C27-1	Original release.	Aug. 19, 2016

1 Certificate of Conformity

Product: Orbi Router (refer to item 3.1 for more details)

Brand: NETGEAR

Test Model: RBR50

Series Model: RBS50

Sample Status: Engineering sample

Applicant: NETGEAR, INC.

Test Date: Jun. 20 ~ Aug. 19, 2016

Standard: 47 CFR FCC Part 15, Subpart E (Section 15.407)
ANSI C63.10:2013

The above equipment has been tested by **Bureau Veritas Consumer Products Services (H.K.) Ltd., Taoyuan Branch**, and found compliance with the requirement of the above standards. The test record, data evaluation & Equipment Under Test (EUT) configurations represented herein are true and accurate accounts of the measurements of the sample's EMC characteristics under the Conditions specified in this report.

Prepared by :  , **Date:** Aug. 19, 2016
Polly Chien / Specialist

Approved by :  , **Date:** Aug. 19, 2016
Ken Liu / Senior Manager

2 Summary of Test Results

47 CFR FCC Part 15, Subpart E (SECTION 15.407)			
FCC Clause	Test Item	Result	Remarks
15.407(b)(6)	AC Power Conducted Emissions	Pass	Meet the requirement of limit. Minimum passing margin is -16.10dB at 0.15391MHz.
15.407(b)(1/2/3/4(i/ii)/6)	Radiated Emissions & Band Edge Measurement	Pass	Meet the requirement of limit. Minimum passing margin is -0.1dB at 5150.00MHz.
15.407(a)(1/2/3)	Max Average Transmit Power	Pass	Meet the requirement of limit.
15.407(a)(1/2/3)	Peak Power Spectral Density	Pass	Meet the requirement of limit.
15.407(e)	6dB bandwidth	Pass	Meet the requirement of limit. (U-NII-3 Band only)
15.407(g)	Frequency Stability	Pass	Meet the requirement of limit.
15.203	Antenna Requirement	PASS	Antenna connector is I-PEX not a standard connector.

*For U-NII-3 band compliance with rule part 15.407(b)(4)(i), the OBE test plots were recorded in Annex A.

2.1 Measurement Uncertainty

Where relevant, the following measurement uncertainty levels have been estimated for tests performed on the EUT as specified in CISPR 16-4-2:

Measurement	Frequency	Expanded Uncertainty (k=2) (±)
Conducted Emissions at mains ports	150kHz ~ 30MHz	2.44 dB
Radiated Emissions up to 1 GHz	30MHz ~ 200MHz	3.59 dB
	200MHz ~ 1000MHz	3.60 dB
Radiated Emissions above 1 GHz	1GHz ~ 18GHz	2.29 dB
	18GHz ~ 40GHz	2.29 dB

2.2 Modification Record

There were no modifications required for compliance.

3 General Information

3.1 General Description of EUT

Product	Orbi Router (Refer to note for more details)
Brand	NETGEAR
Test Model	RBR50
Series Model	RBS50
Model Difference	Refer to note for more details
Sample Status	Engineering sample
Power Supply Rating	12Vdc from adapter
Modulation Type	256QAM, 64QAM, 16QAM, QPSK, BPSK
Modulation Technology	OFDM
Transfer Rate	802.11a: 54/48/36/24/18/12/9/6Mbps 802.11n: up to 600.0Mbps 802.11ac: up to 1733.0Mbps
Operating Frequency	5180 ~ 5240MHz, 5745 ~ 5825MHz
Number of Channel	5180 ~ 5240MHz: 4 for 802.11a, 802.11n (HT20), 802.11ac (VHT20) 2 for 802.11n (HT40), 802.11ac (VHT40) 1 for 802.11ac (VHT80) 5745 ~ 5825MHz: 5 for 802.11a, 802.11n (HT20), 802.11ac (VHT20) 2 for 802.11n (HT40), 802.11ac (VHT40) 1 for 802.11ac (VHT80)
Output Power	CDD Mode: 5180 ~ 5240MHz: 900.332mW 5745 ~ 5825MHz: 934.132mW Beamforming_NSS1 Mode: 5180 ~ 5240MHz: 820.722mW 5745 ~ 5825MHz: 619.725mW Beamforming_NSS 2 Mode: 5745 ~ 5825MHz: 894.270mW
Antenna Type	Refer to Note
Antenna Connector	Refer to Note
Accessory Device	Adapter
Data Cable Supplied	1.95m RJ45 non-shielded cable w/o core

Note:

1. All models are electrically identical except software firmware. Model: RBR50 is the representative for final test.

Brand	Model	Product Name	RF Module Brand / Model	Difference
NETGEAR	RBR50	Orbi Router	Dakota / IPQ-4019	software firmware: RBR50_V1.1.0.16 Master mode only
			Cascade / QCA9984	
	RBS50	Orbi Satellite	Dakota / IPQ-4019	software firmware: RBS50_V1.1.0.16 Master mode and Client mode for U-NII-3 band
			Cascade / QCA9984	

Note: RF Module Dakota / IPQ-4019 support WLAN 2.4GHz band & U-NII-1 band functionally.
Cascade / QCA9984 support WLAN U-NII-3 band functionally.

2. The EUT incorporates a MIMO function. Physically, the EUT provides 4 completed transmitters and 4 receivers.

Band	Modulation Mode	Beamforming Mode	TX Function
5GHz U-NII-1Band	802.11a	Not Support	2TX
	802.11n (HT20)	Support (CDD / NSS=1)	2TX
	802.11n (HT40)	Support (CDD / NSS=1)	2TX
	802.11ac (VHT20)	Support (CDD / NSS=1)	2TX
	802.11ac (VHT40)	Support (CDD / NSS=1)	2TX
	802.11ac (VHT80)	Support (CDD / NSS=1)	2TX
5GHz U-NII-3 Band	802.11a	Not Support	4TX
	802.11n (HT20)	Support (CDD / NSS=1 / NSS=2)	4TX
	802.11n (HT40)	Support (CDD / NSS=1 / NSS=2)	4TX
	802.11ac (VHT20)	Support (CDD / NSS=1 / NSS=2)	4TX
	802.11ac (VHT40)	Support (CDD / NSS=1 / NSS=2)	4TX
	802.11ac (VHT80)	Support (CDD / NSS=1 / NSS=2)	4TX

* The modulation and bandwidth are similar for 802.11n mode for 20MHz/40MHz and 802.11ac mode for 20MHz/40MHz, therefore investigated worst case to representative mode in test report. (Final test mode refer section 3.2.1)

* For 5GHz band 802.11n and 802.11ac, CDD mode is the worst case for final radiated emission and power line conducted emission tests after pretesting CDD mode and beamforming mode.

3. The following antennas were provided to the EUT.

Ant. Type	Dipole			
Connector Type	I-PEX			
Antenna Gain(dBi)				
Item	2.4G	5G Band 1	5G Band 4	
Ant. 0			3.54	
Ant. 1			3.79	
Ant. 2			3.76	
Ant. 3			3.79	
Ant. 4	2.42	3.41		
Ant. 5	2.68	3.72		
Composite Antenna Gain(dBi)				
Item	2.4G	5G Band 1	5G Band 4	
	CDD / Beamforming NSS1	CDD / Beamforming NSS1	CDD / Beamforming NSS1	Beamforming NSS2
Ant. 0			8.068	5.058
Ant. 1				
Ant. 2				
Ant. 3				
Ant. 4	3.448	5.812		
Ant. 5				

4. The cascade module card has type C, type D and different gaskets on the following modes. Mode C was the worst case for final test.

Mode	Description
A	Type C on chain 1, 2, 3, and 4. Triangular gaskets on chain 1, 2, 3, and 4.
B	Type C on chain 1, 2, 3, and 4. Triangular gaskets on chain 1, 2, and 3. No gasket on chain 4.
C	Type C on chain 1, 2, 3, and 4. Rectangular gaskets on chain 1, 2, 3, and 4.
D	Type C on chain 1, 2, 3, and 4. Rectangular gaskets on chain 1, 2, and 3. No gasket on chain 4.
E	Type C on chain 1, 2, and 3. Type D on chain 4. Triangular gaskets on chain 1, 2, and 3. No gasket on chain 4.

5. The EUT uses following adapters.

Adapter 1	
Brand	NETGEAR
Model	AD2080F20
PN	332-10883-01
Input Power	100-240Vdc, 50/60Hz 1.0A
Output Power	12Vdc, 3.5A
Power Line	1.8m power cable without core attached on adapter

Adapter 2	
Brand	NETGEAR
Model	2ABN042F NA
PN	332-10888-01
Input Power	100-240Vdc, 50/60Hz 1.3A
Output Power	12Vdc, 3.5A
Power Line	1.85m power cable without core attached on adapter

* After pre-testing, adapter 2 was the worst case for final test.

6. Spurious emission of the simultaneous operation (2.4GHz and 5GHz) has been evaluated and no non-compliance was found.

3.2 Description of Test Modes

FOR 5180 ~ 5240MHz:

4 channels are provided for 802.11a, 802.11n (HT20), 802.11ac (VHT20):

Channel	Frequency	Channel	Frequency
36	5180 MHz	44	5220 MHz
40	5200 MHz	48	5240 MHz

2 channels are provided for 802.11n (HT40), 802.11ac (40MHz):

Channel	Frequency	Channel	Frequency
38	5190 MHz	46	5230 MHz

1 channel is provided for 802.11ac (VHT80):

Channel	Frequency
42	5210MHz

FOR 5745 ~ 5825MHz:

5 channels are provided for 802.11a, 802.11n (HT20), 802.11ac (VHT20):

Channel	Frequency	Channel	Frequency
149	5745MHz	161	5805MHz
153	5765MHz	165	5825MHz
157	5785MHz		

2 channels are provided for 802.11n (HT40), 802.11ac (VHT40):

Channel	Frequency	Channel	Frequency
151	5755MHz	159	5795MHz

1 channel is provided for 802.11ac (VHT80):

Channel	Frequency
155	5775MHz

3.2.1 Test Mode Applicability and Tested Channel Detail

EUT Configure Mode	Applicable to				Description
	RE \geq 1G	RE<1G	PLC	APCM	
A	√	-	√	√	EUT power from adapter 1
B	-	√	√	-	EUT power from adapter 2

Where RE \geq 1G: Radiated Emission above 1GHz & Bandedge Measurement
 RE<1G: Radiated Emission below 1GHz
 PLC: Power Line Conducted Emission
 APCM: Antenna Port Conducted Measurement

Note:

- The EUT was positioned on the Z-plane during testing.
- "-" means no effect.

Radiated Emission Test (Above 1GHz):

- Pre-Scan has been conducted to determine the worst-case mode from all possible combinations between available modulations, data rates and antenna ports (if EUT with antenna diversity architecture).
- Following channel(s) was (were) selected for the final test as listed below.

EUT CONFIGURE MODE	MODE	FREQ. BAND (MHz)	AVAILABLE CHANNEL	TESTED CHANNEL	MODULATION TECHNOLOGY	MODULATION TYPE	DATA RATE (Mbps)
A	802.11a	5180-5240	36 to 48	36, 40, 48	OFDM	BPSK	6.0
A	802.11ac (VHT20)		36 to 48	36, 40, 48	OFDM	BPSK	13.0
A	802.11ac (VHT40)		38 to 46	38, 46	OFDM	BPSK	27.0
A	802.11ac (VHT80)		42	42	OFDM	BPSK	58.5
A	802.11a	5745-5825	149 to 165	149, 157, 165	OFDM	BPSK	6.0
A	802.11ac (VHT20)		149 to 165	149, 157, 165	OFDM	BPSK	13.0
A	802.11ac (VHT40)		151 to 159	151, 159	OFDM	BPSK	27.0
A	802.11ac (VHT80)		155	155	OFDM	BPSK	130.0

Radiated Emission Test (Below 1GHz):

- Pre-Scan has been conducted to determine the worst-case mode from all possible combinations between available modulations, data rates and antenna ports (if EUT with antenna diversity architecture).
- Following channel(s) was (were) selected for the final test as listed below.

EUT CONFIGURE MODE	MODE	FREQ. BAND (MHz)	AVAILABLE CHANNEL	TESTED CHANNEL	MODULATION TECHNOLOGY	MODULATION TYPE	DATA RATE (Mbps)
B	802.11a	5180-5240	36 to 48	149	OFDM	BPSK	6.0
	802.11a	5745-5825	149 to 165		OFDM	BPSK	6.0

Power Line Conducted Emission Test:

- Pre-Scan has been conducted to determine the worst-case mode from all possible combinations between available modulations, data rates and antenna ports (if EUT with antenna diversity architecture).
- Following channel(s) was (were) selected for the final test as listed below.

EUT CONFIGURE MODE	MODE	FREQ. BAND (MHz)	AVAILABLE CHANNEL	TESTED CHANNEL	MODULATION TECHNOLOGY	MODULATION TYPE	DATA RATE (Mbps)
A, B	802.11a	5180-5320	36 to 64	149	OFDM	BPSK	6.0
	802.11a	5745-5825	149 to 165		OFDM	BPSK	6.0

Antenna Port Conducted Measurement:

- This item includes all test value of each mode, but only includes spectrum plot of worst value of each mode.
- Pre-Scan has been conducted to determine the worst-case mode from all possible combinations between available modulations, data rates and antenna ports (if EUT with antenna diversity architecture).
- Following channel(s) was (were) selected for the final test as listed below.

EUT CONFIGURE MODE	MODE	FREQ. BAND (MHz)	AVAILABLE CHANNEL	TESTED CHANNEL	MODULATION TECHNOLOGY	MODULATION TYPE	DATA RATE (Mbps)
A	802.11a	5180-5240	36 to 48	36, 40, 48	OFDM	BPSK	6.0
A	802.11ac (VHT20)		36 to 48	36, 40, 48	OFDM	BPSK	13.0
A	802.11ac (VHT40)		38 to 46	38, 46	OFDM	BPSK	27.0
A	802.11ac (VHT80)		42	42	OFDM	BPSK	58.5
A	802.11a	5745-5825	149 to 165	149, 157, 165	OFDM	BPSK	6.0
A	802.11ac (VHT20)		149 to 165	149, 157, 165	OFDM	BPSK	13.0
A	802.11ac (VHT40)		151 to 159	151, 159	OFDM	BPSK	27.0
A	802.11ac (VHT80)		155	155	OFDM	BPSK	130.0

Test Condition:

Applicable to	Environmental Conditions	Input Power	Tested by
RE≥1G	25 deg. C, 65% RH	120Vac, 60Hz	Chris Lin
	28 deg. C, 69% RH	120Vac, 60Hz	Alan Wu
RE<1G	25 deg. C, 69% RH	120Vac, 60Hz	Matthew Yang
PLC	25 deg. C, 75% RH	120Vac, 60Hz	Chris Lin, Matthew Yang
APCM	25 deg. C, 60% RH	120Vac, 60Hz	Leo Tsai

3.3 Duty Cycle of Test Signal

Duty cycle of test signal is $\geq 98\%$, duty factor is not required.

Duty cycle of test signal is $< 98\%$, duty factor shall be considered.

5GHz U-NII-1Band:

CDD Mode

802.11a: Duty cycle = $2.055/2.142 = 0.959$, Duty factor = $10 * \log(1/0.959) = 0.18$

802.11ac (VHT20): Duty cycle = $4.980/5.073 = 0.982$

802.11ac (VHT40): Duty cycle = $2.415/2.505 = 0.964$, Duty factor = $10 * \log(1/0.964) = 0.16$

802.11ac (VHT80): Duty cycle = $1.125/1.227 = 0.917$, Duty factor = $10 * \log(1/0.917) = 0.38$

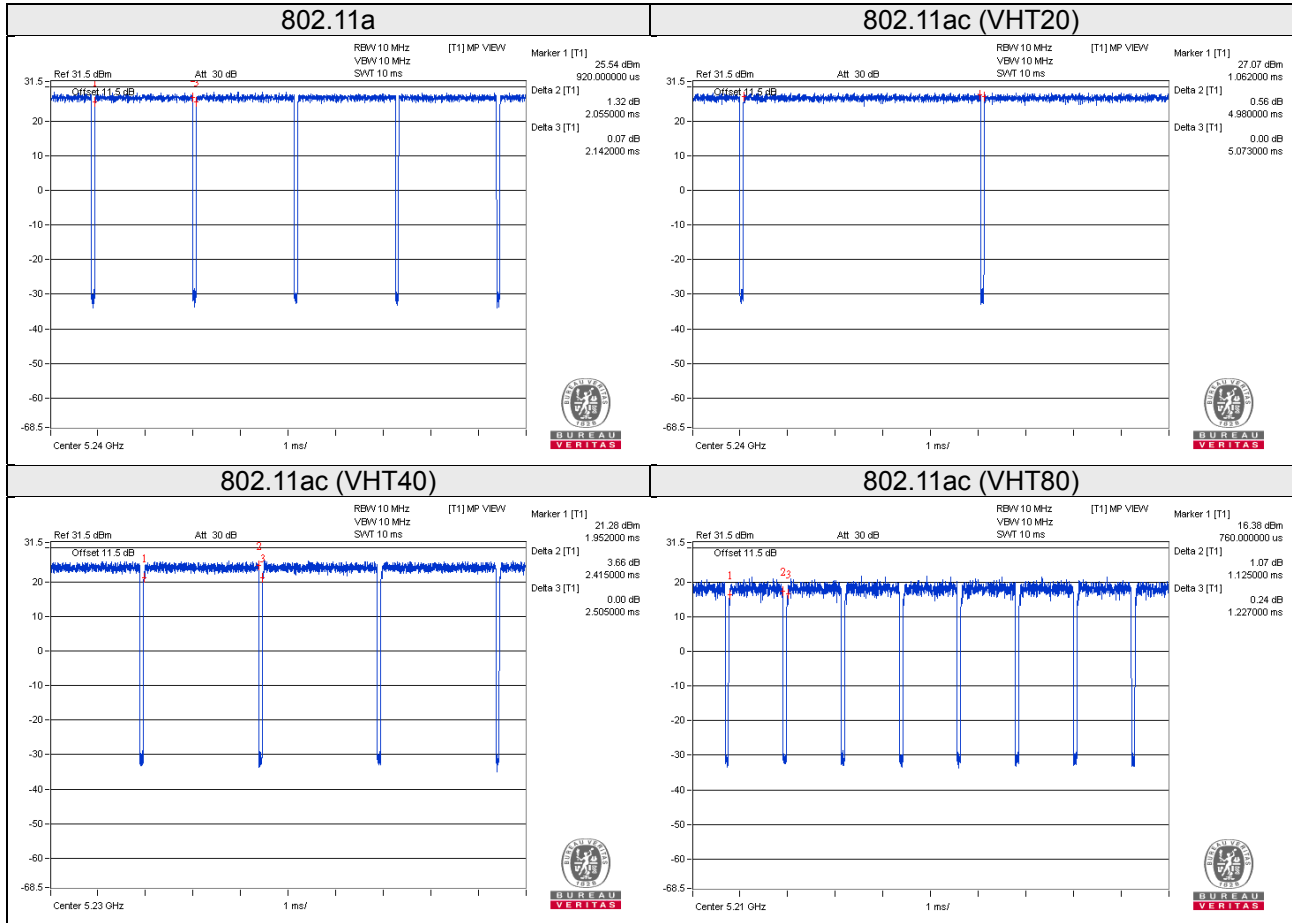

Beamforming_NSS1 Mode

802.11ac (VHT20): Duty cycle = 4.990/5.090 = 0.9803

802.11ac (VHT40): Duty cycle = 2.430/2.525 = 0.962, Duty factor = $10 * \log(1/0.962) = 0.17$

802.11ac (VHT80): Duty cycle = 1.140/1.245 = 0.916, Duty factor = $10 * \log(1/0.916) = 0.38$

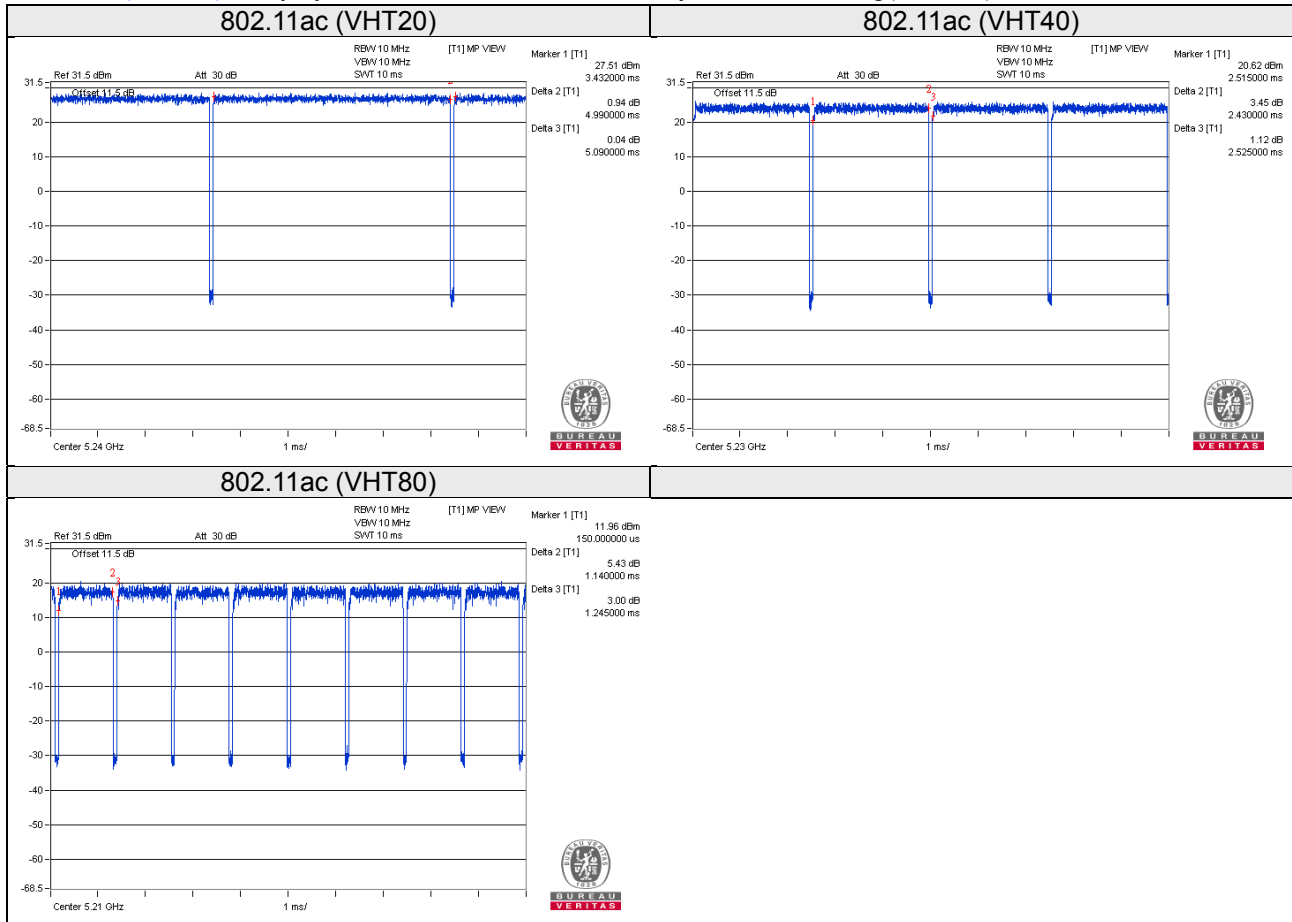

5GHz U-NII-3 Band:
CDD Mode

802.11a: Duty cycle = $2.045/2.137 = 0.957$, Duty factor = $10 * \log(1/0.957) = 0.19$

802.11ac (VHT20): Duty cycle = $4.970/5.070 = 0.9802$

802.11ac (VHT40): Duty cycle = $2.418/2.493 = 0.970$, Duty factor = $10 * \log(1/0.970) = 0.13$

802.11ac (VHT80): Duty cycle = $1.142/1.217 = 0.938$, Duty factor = $10 * \log(1/0.938) = 0.28$

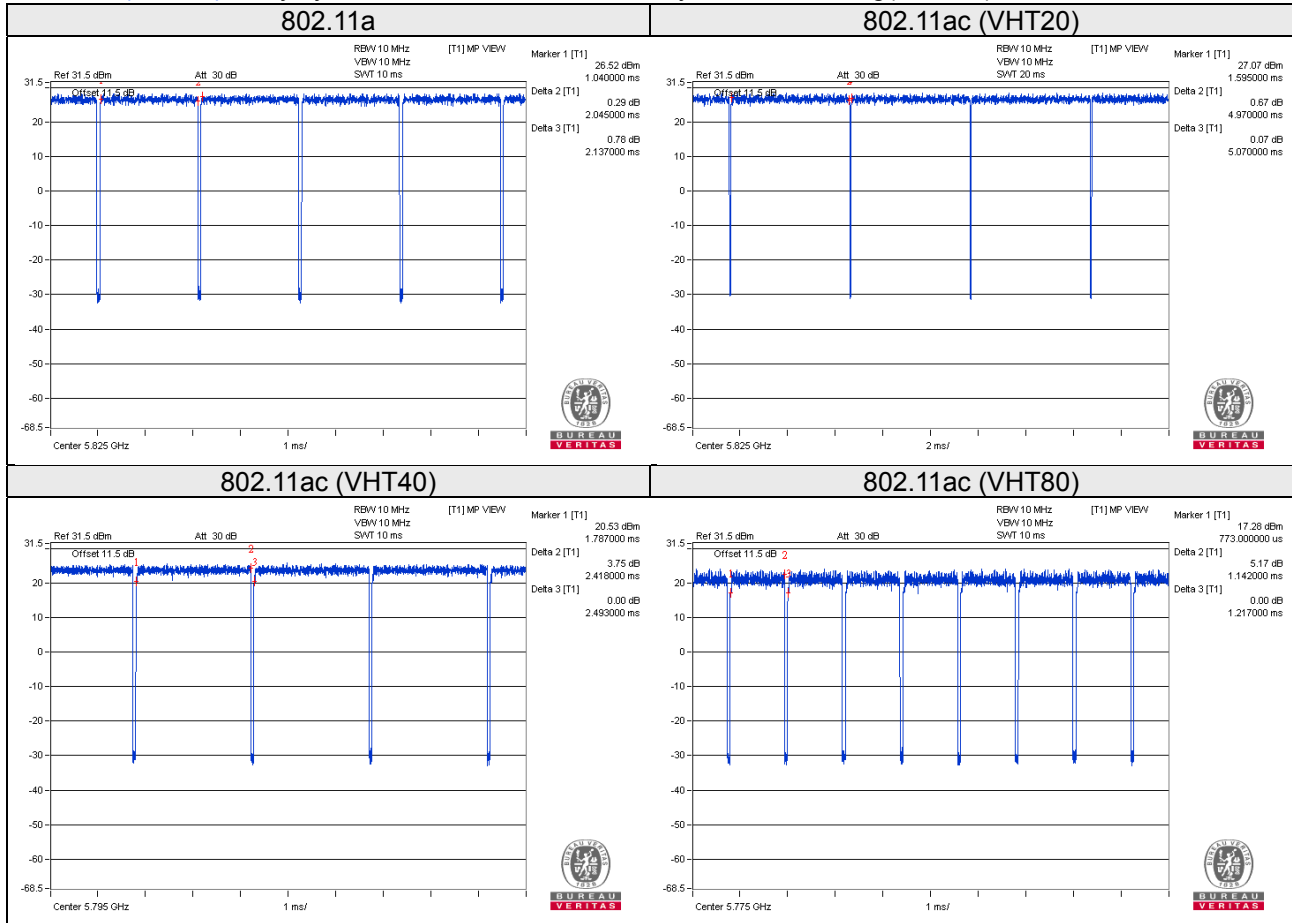

Beamforming_NSS1 Mode

802.11ac (VHT20): Duty cycle = 4.990/5.085 = 0.981

802.11ac (VHT40): Duty cycle = 2.425/2.520 = 0.962, Duty factor = $10 * \log(1/0.962) = 0.17$

802.11ac (VHT80): Duty cycle = 1.129/1.217 = 0.928, Duty factor = $10 * \log(1/0.928) = 0.33$

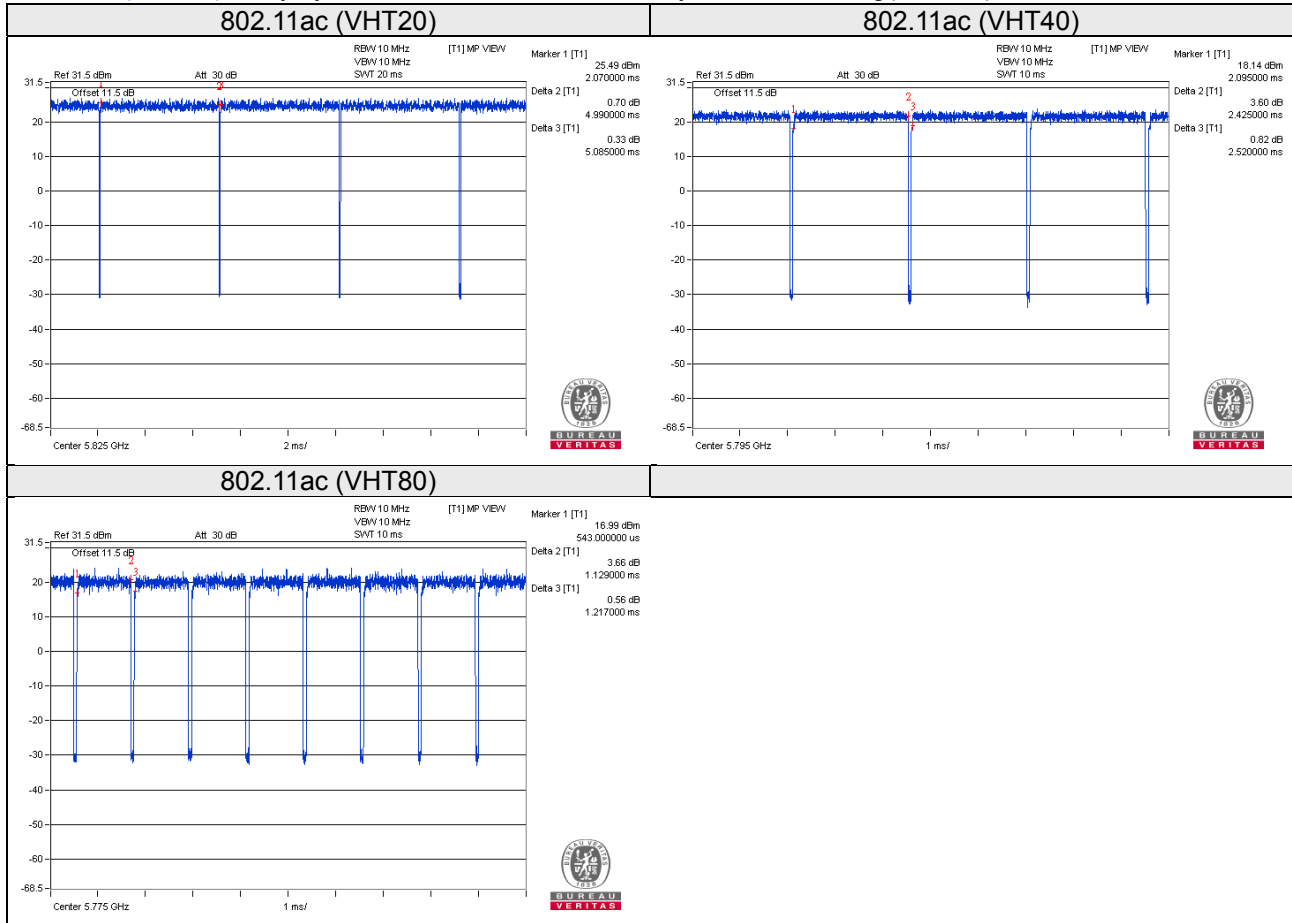

Beamforming_NSS2 Mode

802.11ac (VHT20): Duty cycle = 5.001/5.078 = 0.985

802.11ac (VHT40): Duty cycle = 2.427/2.514 = 0.965, Duty factor = $10 * \log(1/0.965) = 0.15$

802.11ac (VHT80): Duty cycle = 1.137/1.209 = 0.940, Duty factor = $10 * \log(1/0.940) = 0.27$

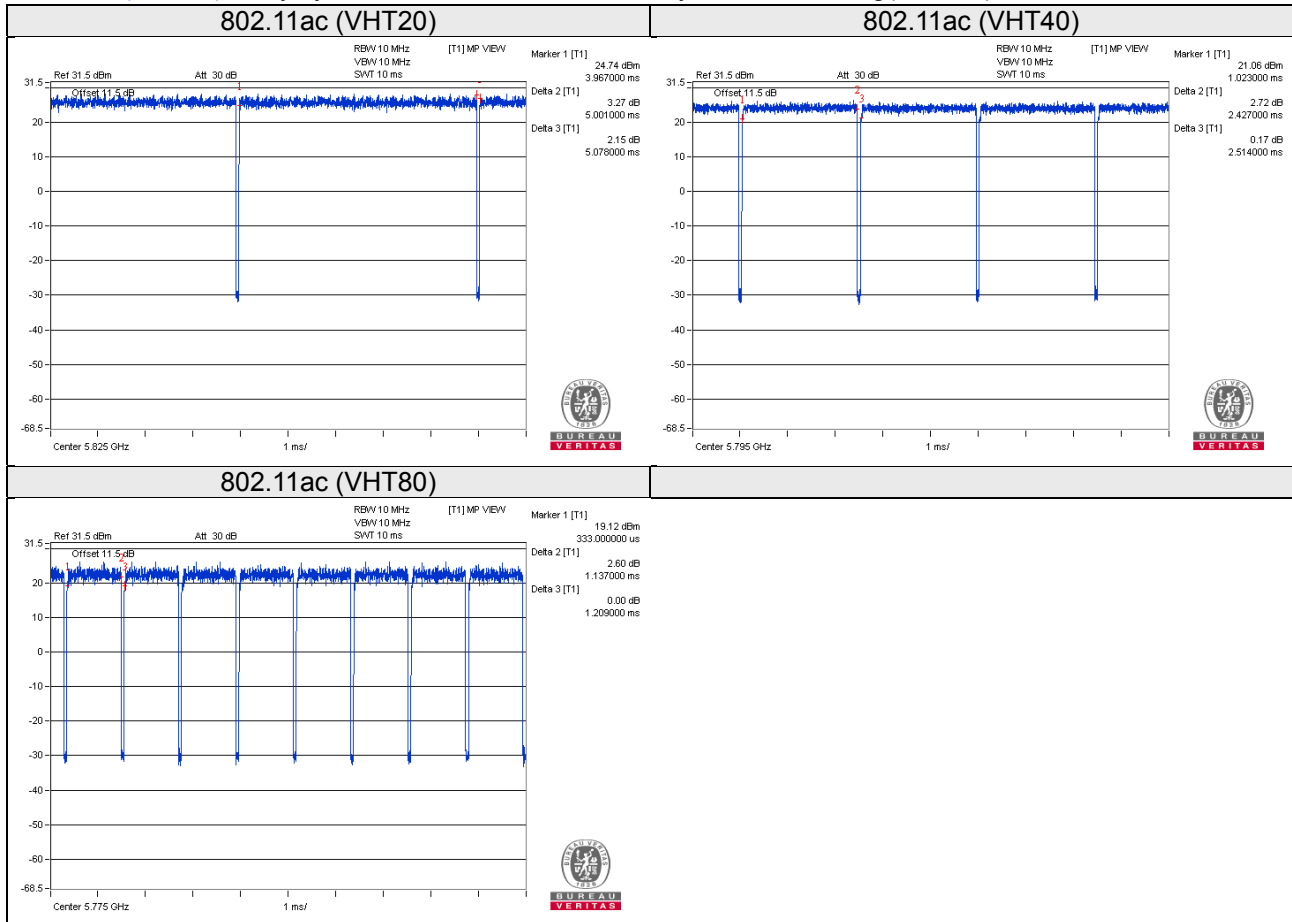

3.4 Description of Support Units

The EUT has been tested as an independent unit together with other necessary accessories or support units. The following support units or accessories were used to form a representative test configuration during the tests.

ID	Product	Brand	Model No.	Serial No.	FCC ID	Remarks
A.	Notebook	DELL	E5410	6RP2YM1	FCC DoC Approved	-
B.	USB 3.0 Flash	HP	v250W	01	FCC DoC Approved	-
C.	Load	N/A	N/A	N/A	N/A	-

Note:

1. All power cords of the above support units are non-shielded (1.8m).
2. Item A acted as a communication partner to transfer data.

ID	Descriptions	Qty.	Length (m)	Shielding (Yes/No)	Cores (Qty.)	Remarks
1.	RJ45	3	1.8	N	0	-
2.	RJ45	1	10	N	0	-

3.4.1 Configuration of System under Test

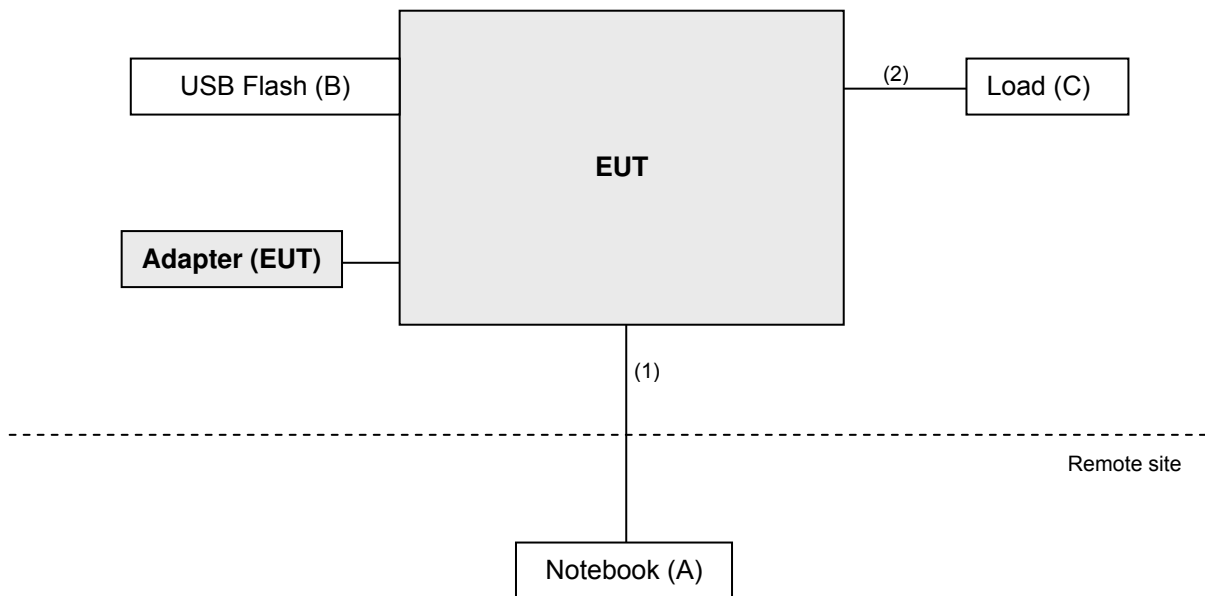

3.5 General Description of Applied Standard

The EUT is a RF Product. According to the specifications of the manufacturer, it must comply with the requirements of the following standards:

FCC Part 15, Subpart E (15.407)
789033 D02 General UNII Test Procedures New Rules v01r02
662911 D01 Multiple Transmitter Output v02r01
 ANSI C63.10:2013

All test items have been performed and recorded as per the above standards.

Note: The EUT has been verified to comply with the requirements of FCC Part 15, Subpart B, Class B (DoC). The test report has been issued separately.

4 Test Types and Results

4.1 Radiated Emission and Bandedge Measurement

4.1.1 Limits of Radiated Emission and Bandedge Measurement

Radiated emissions which fall in the restricted bands must comply with the radiated emission limits specified as below table.

Frequencies (MHz)	Field Strength (microvolts/meter)	Measurement Distance (meters)
0.009 ~ 0.490	2400/F(kHz)	300
0.490 ~ 1.705	24000/F(kHz)	30
1.705 ~ 30.0	30	30
30 ~ 88	100	3
88 ~ 216	150	3
216 ~ 960	200	3
Above 960	500	3

NOTE:

1. The lower limit shall apply at the transition frequencies.
2. Emission level (dBuV/m) = 20 log Emission level (uV/m).
3. For frequencies above 1000MHz, the field strength limits are based on average detector, however, the peak field strength of any emission shall not exceed the maximum permitted average limits, specified above by more than 20dB under any condition of modulation.

LIMITS OF UNWANTED EMISSION OUT OF THE RESTRICTED BANDS

Applicable To	Limit	
789033 D02 General UNII Test Procedure New Rules v01r02	FIELD STRENGTH at 3m	
	PK:74 (dBuV/m)	AV:54 (dBuV/m)
Applicable To	EIRP Limit	Equivalent Field Strength at 3m
15.407(b)(1)	PK:-27 (dBm/MHz)	PK:68.2 (dBuV/m)
15.407(b)(2)		
15.407(b)(3)		
15.407(b)(4)(i)	PK: -27 (dBm/MHz) ^{*1} PK: 10 (dBm/MHz) ^{*2} PK: 15.6 (dBm/MHz) ^{*3} PK: 27 (dBm/MHz) ^{*4}	PK: 68.2 (dBuV/m) ^{*1} PK: 105.2 (dBuV/m) ^{*2} PK: 110.8 (dBuV/m) ^{*3} PK: 122.2 (dBuV/m) ^{*4}
15.407(b)(4)(ii)	FIELD STRENGTH at 3m / § 15.247(d),	
	PK:74 (dBuV/m)	AV:54 (dBuV/m)
^{*1} beyond 75 MHz or more above of the band edge. ^{*2} below the band edge increasing linearly to 10 dBm/MHz at 25 MHz above. ^{*3} below the band edge increasing linearly to a level of 15.6 dBm/MHz at 5 MHz above. ^{*4} from 5 MHz above or below the band edge increasing linearly to a level of 27 dBm/MHz at the band edge.		

NOTE: The following formula is used to convert the equipment isotropic radiated power (eirp) to field strength:

$$E = \frac{1000000 \sqrt{30P}}{3} \mu\text{V/m, where } P \text{ is the eirp (Watts).}$$

4.1.2 Test Instruments

Tested date: Jun. 20 ~ Jul. 15, 2016

Description & Manufacturer	Model No.	Serial No.	Cal. Date	Cal. Due
Test Receiver ROHDE & SCHWARZ	ESCI	100424	Oct. 12, 2015	Oct. 11, 2016
Spectrum Analyzer ROHDE & SCHWARZ	FSP40	100041	Sep. 02, 2015	Sep. 01, 2016
BILOG Antenna SCHWARZBECK	VULB9168	9168-155	Jan. 07, 2016	Jan. 06, 2017
HORN Antenna SCHWARZBECK	BBHA 9120D	9120D-1170	Jan. 08, 2016	Jan. 07, 2017
HORN Antenna SCHWARZBECK	BBHA 9170	BBHA9170241	Jan. 18, 2016	Jan. 17, 2017
HORN Antenna SCHWARZBECK	BBHA 9170	BBHA9170241	Jan. 18, 2016	Jan. 17, 2017
Preamplifier Agilent	8449B	3008A01960	Aug. 09, 2015	Aug. 08, 2016
Preamplifier Agilent	8447D	2944A10631	Aug. 09, 2015	Aug. 08, 2016
RF signal cable HUBER+SUHNER	SUCOFLEX 104	Cable-CH4-02(295012+309220)	Aug. 09, 2015	Aug. 08, 2016
RF signal cable HUBER+SUHNER	SUCOFLEX 104	Cable-CH4-03(250724)	Aug. 09, 2015	Aug. 08, 2016
Software BV ADT	ADT_Radiated_ V7.6.15.9.4	NA	NA	NA
Antenna Tower inn-co GmbH	MA 4000	010303	NA	NA
Antenna Tower Controller BV ADT	AT100	AT93021703	NA	NA
Turn Table BV ADT	TT100	TT93021703	NA	NA
Turn Table Controller BV ADT	SC100.	SC93021703	NA	NA
High Speed Peak Power Meter	ML2495A	1232003	Oct. 07, 2015	Oct. 06, 2016
Power Sensor	MA2411B	1207333	Oct. 07, 2015	Oct. 06, 2016
WIT Standard Temperature And Humidity Chamber	TH-4S-C	W981030	Jun. 08, 2016	Jun. 07, 2017

- Note: 1. The calibration interval of the above test instruments is 12 months and the calibrations are traceable to NML/ROC and NIST/USA.
 2. The test was performed in HwaYa Chamber 4.
 3. The horn antenna and preamplifier (model: 8449B) are used only for the measurement of emission frequency above 1GHz if tested.
 4. The FCC Site Registration No. is 460141.
 5. The IC Site Registration No. is IC7450F-4.

4.1.3 Test Procedure

- a. The EUT was placed on the top of a rotating table 0.8 meters (for below 1GHz) / 1.5 meters (for above 1GHz) above the ground at 3 meter chamber room for test. The table was rotated 360 degrees to determine the position of the highest radiation.
- b. The EUT was set 3 meters away from the interference-receiving antenna, which was mounted on the top of a variable-height antenna tower.
- c. The height of antenna is varied from one meter to four meters above the ground to determine the maximum value of the field strength. Both horizontal and vertical polarizations of the antenna are set to make the measurement.
- d. For each suspected emission, the EUT was arranged to its worst case and then the antenna was tuned to heights from 1 meter to 4 meters and the rotatable table was turned from 0 degrees to 360 degrees to find the maximum reading.
- e. The test-receiver system was set to quasi-peak detect function and specified bandwidth with maximum hold mode when the test frequency is below 1 GHz.
- f. The test-receiver system was set to peak and average detect function and specified bandwidth with maximum hold mode when the test frequency is above 1 GHz. If the peak reading value also meets average limit, measurement with the average detector is unnecessary.

Note:

1. The resolution bandwidth and video bandwidth of test receiver/spectrum analyzer is 120kHz for Quasi-peak detection (QP) at frequency below 1GHz.
2. The resolution bandwidth of test receiver/spectrum analyzer is 1 MHz and the video bandwidth is 3 MHz for Peak detection (PK) at frequency above 1GHz.
3. The resolution bandwidth of test receiver/spectrum analyzer is 1MHz and the video bandwidth is 3MHz for RMS Average (Duty cycle < 98%) for Average detection (AV) at frequency above 1GHz, then the measurement results was added to a correction factor ($10 \log(1/\text{duty cycle})$).
4. The resolution bandwidth of test receiver/spectrum analyzer is 1MHz and the video bandwidth is 10Hz (Duty cycle $\geq 98\%$) for Average detection (AV) at frequency above 1GHz.
5. All modes of operation were investigated and the worst-case emissions are reported.

4.1.4 Deviation from Test Standard

No deviation.

4.1.5 Test Setup

<Frequency Range 30MHz~1GHz>

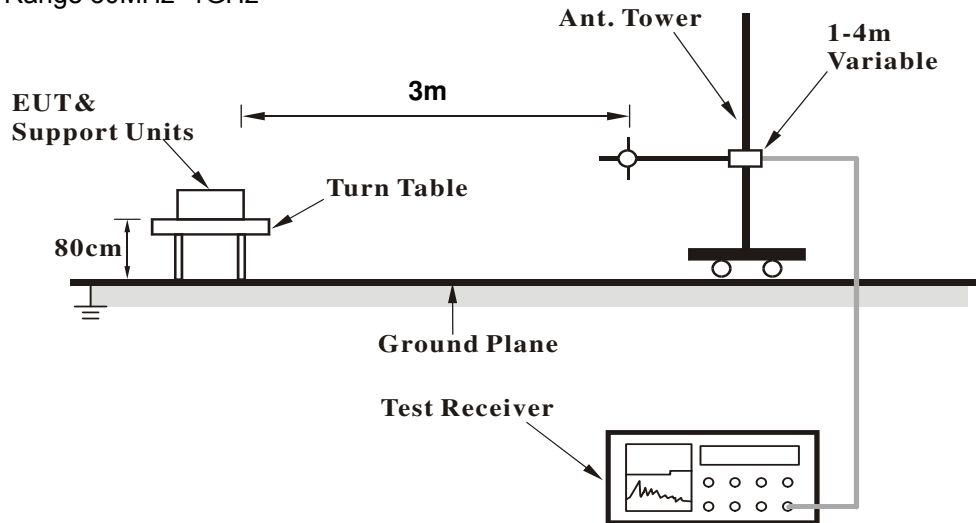

<Frequency Range above 1GHz>

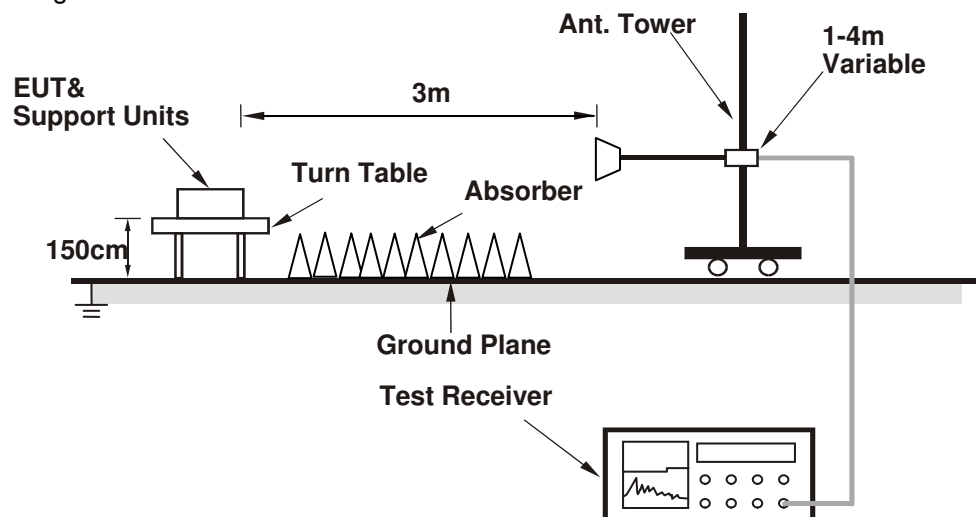

For the actual test configuration, please refer to the attached file (Test Setup Photo).

4.1.6 EUT Operating Conditions

- Placed the EUT on the testing table.
- Prepared a notebook to act as a communication partner and placed it outside of testing area.
- The communication partner connected with EUT via a RJ45 cable and ran a test program (provided by manufacturer) to enable EUT under transmission condition continuously at specific channel frequency.
- The communication partner sent data to EUT by command "PING".
- The necessary accessories enable the system in full functions.

4.1.7 Test Results

Above 1GHz Worst-Case Data:

802.11a

CHANNEL	TX Channel 36	DETECTOR FUNCTION	Peak (PK)
FREQUENCY RANGE	1GHz ~ 40GHz		Average (AV)

ANTENNA POLARITY & TEST DISTANCE: HORIZONTAL AT 3 M								
NO.	FREQ. (MHz)	EMISSION LEVEL (dBuV/m)	LIMIT (dBuV/m)	MARGIN (dB)	ANTENNA HEIGHT (m)	TABLE ANGLE (Degree)	RAW VALUE (dBuV)	CORRECTION FACTOR (dB/m)
1	5150.00	58.7 PK	74.0	-15.3	1.00 H	289	53.20	5.50
2	5150.00	45.6 AV	54.0	-8.4	1.00 H	289	40.10	5.50
3	*5180.00	106.8 PK			1.00 H	289	67.30	39.50
4	*5180.00	97.2 AV			1.00 H	289	57.70	39.50
5	#10360.00	59.1 PK	74.0	-14.9	1.36 H	98	41.60	17.50
6	#10360.00	45.6 AV	54.0	-8.4	1.36 H	98	28.10	17.50
ANTENNA POLARITY & TEST DISTANCE: VERTICAL AT 3 M								
NO.	FREQ. (MHz)	EMISSION LEVEL (dBuV/m)	LIMIT (dBuV/m)	MARGIN (dB)	ANTENNA HEIGHT (m)	TABLE ANGLE (Degree)	RAW VALUE (dBuV)	CORRECTION FACTOR (dB/m)
1	5150.00	71.4 PK	74.0	-2.6	1.18 V	159	65.90	5.50
2	5150.00	53.7 AV	54.0	-0.3	1.18 V	159	48.20	5.50
3	*5180.00	116.0 PK			1.18 V	159	76.50	39.50
4	*5180.00	105.6 AV			1.18 V	159	66.10	39.50
5	#10360.00	59.8 PK	74.0	-14.2	1.00 V	227	42.30	17.50
6	#10360.00	46.9 AV	54.0	-7.1	1.00 V	227	29.40	17.50

REMARKS:

- Emission Level(dBuV/m) = Raw Value(dBuV) + Correction Factor(dB/m)
- Correction Factor(dB/m) = Antenna Factor(dB/m) + Cable Factor(dB)
– Pre-Amplifier Factor(dB)
- The other emission levels were very low against the limit.
- Margin value = Emission Level – Limit value
- " * ": Fundamental frequency.
- " # ": The radiated frequency is out of the restricted band.

CHANNEL	TX Channel 40	DETECTOR FUNCTION	Peak (PK)
FREQUENCY RANGE	1GHz ~ 40GHz		Average (AV)

ANTENNA POLARITY & TEST DISTANCE: HORIZONTAL AT 3 M

NO.	FREQ. (MHz)	EMISSION LEVEL (dBuV/m)	LIMIT (dBuV/m)	MARGIN (dB)	ANTENNA HEIGHT (m)	TABLE ANGLE (Degree)	RAW VALUE (dBuV)	CORRECTION FACTOR (dB/m)
1	5150.00	58.1 PK	74.0	-15.9	1.06 H	288	52.60	5.50
2	5150.00	45.5 AV	54.0	-8.5	1.06 H	288	40.00	5.50
3	*5200.00	111.0 PK			1.06 H	288	71.40	39.60
4	*5200.00	100.7 AV			1.06 H	288	61.10	39.60
5	#10400.00	59.5 PK	74.0	-14.5	1.03 H	65	41.50	18.00
6	#10400.00	46.4 AV	54.0	-7.6	1.03 H	65	28.40	18.00

ANTENNA POLARITY & TEST DISTANCE: VERTICAL AT 3 M

NO.	FREQ. (MHz)	EMISSION LEVEL (dBuV/m)	LIMIT (dBuV/m)	MARGIN (dB)	ANTENNA HEIGHT (m)	TABLE ANGLE (Degree)	RAW VALUE (dBuV)	CORRECTION FACTOR (dB/m)
1	5150.00	67.7 PK	74.0	-6.3	1.00 V	1	62.20	5.50
2	5150.00	53.5 AV	54.0	-0.5	1.00 V	1	48.00	5.50
3	*5200.00	121.2 PK			1.00 V	1	81.60	39.60
4	*5200.00	111.6 AV			1.00 V	1	72.00	39.60
5	#10400.00	59.9 PK	74.0	-14.1	1.10 V	258	41.90	18.00
6	#10400.00	47.6 AV	54.0	-6.4	1.10 V	258	29.60	18.00

REMARKS:

1. Emission Level(dBuV/m) = Raw Value(dBuV) + Correction Factor(dB/m)
2. Correction Factor(dB/m) = Antenna Factor(dB/m) + Cable Factor(dB)
- Pre-Amplifier Factor(dB)
3. The other emission levels were very low against the limit.
4. Margin value = Emission Level – Limit value
5. " * ": Fundamental frequency.
6. " # ": The radiated frequency is out of the restricted band.

CHANNEL	TX Channel 48	DETECTOR FUNCTION	Peak (PK)
FREQUENCY RANGE	1GHz ~ 40GHz		Average (AV)

ANTENNA POLARITY & TEST DISTANCE: HORIZONTAL AT 3 M

NO.	FREQ. (MHz)	EMISSION LEVEL (dBuV/m)	LIMIT (dBuV/m)	MARGIN (dB)	ANTENNA HEIGHT (m)	TABLE ANGLE (Degree)	RAW VALUE (dBuV)	CORRECTION FACTOR (dB/m)
1	*5240.00	110.3 PK			1.07 H	300	70.70	39.60
2	*5240.00	99.8 AV			1.07 H	300	60.20	39.60
3	5350.00	58.7 PK	74.0	-15.3	1.07 H	300	53.00	5.70
4	5350.00	46.3 AV	54.0	-7.7	1.07 H	300	40.60	5.70
5	#10480.00	59.6 PK	74.0	-14.4	1.06 H	32	41.60	18.00
6	#10480.00	46.1 AV	54.0	-7.9	1.06 H	32	28.10	18.00

ANTENNA POLARITY & TEST DISTANCE: VERTICAL AT 3 M

NO.	FREQ. (MHz)	EMISSION LEVEL (dBuV/m)	LIMIT (dBuV/m)	MARGIN (dB)	ANTENNA HEIGHT (m)	TABLE ANGLE (Degree)	RAW VALUE (dBuV)	CORRECTION FACTOR (dB/m)
1	*5240.00	122.8 PK			1.63 V	140	83.20	39.60
2	*5240.00	111.8 AV			1.63 V	140	72.20	39.60
3	5350.00	56.8 PK	74.0	-17.2	1.63 V	140	51.10	5.70
4	5350.00	47.3 AV	54.0	-6.7	1.63 V	140	41.60	5.70
5	#10480.00	61.2 PK	74.0	-12.8	1.10 V	89	43.20	18.00
6	#10480.00	48.9 AV	54.0	-5.1	1.10 V	89	30.90	18.00

REMARKS:

1. Emission Level(dBuV/m) = Raw Value(dBuV) + Correction Factor(dB/m)
2. Correction Factor(dB/m) = Antenna Factor(dB/m) + Cable Factor(dB)
– Pre-Amplifier Factor(dB)
3. The other emission levels were very low against the limit.
4. Margin value = Emission Level – Limit value
5. " * ": Fundamental frequency.
6. " # ": The radiated frequency is out of the restricted band.

CHANNEL	TX Channel 149	DETECTOR FUNCTION	Peak (PK)
FREQUENCY RANGE	1GHz ~ 40GHz		Average (AV)

ANTENNA POLARITY & TEST DISTANCE: HORIZONTAL AT 3 M

NO.	FREQ. (MHz)	EMISSION LEVEL (dBuV/m)	LIMIT (dBuV/m)	MARGIN (dB)	ANTENNA HEIGHT (m)	TABLE ANGLE (Degree)	RAW VALUE (dBuV)	CORRECTION FACTOR (dB/m)
1	#5623.20	58.2 PK	68.2	-10.0	1.00 H	129	52.10	6.10
2	*5745.00	115.7 PK			1.00 H	129	75.30	40.40
3	*5745.00	105.2 AV			1.00 H	129	64.80	40.40
4	#5964.00	59.0 PK	68.2	-9.2	1.00 H	129	52.30	6.70
5	11490.00	61.2 PK	74.0	-12.8	1.10 H	86	41.90	19.30
6	11490.00	47.5 AV	54.0	-6.5	1.10 H	86	28.20	19.30

ANTENNA POLARITY & TEST DISTANCE: VERTICAL AT 3 M

NO.	FREQ. (MHz)	EMISSION LEVEL (dBuV/m)	LIMIT (dBuV/m)	MARGIN (dB)	ANTENNA HEIGHT (m)	TABLE ANGLE (Degree)	RAW VALUE (dBuV)	CORRECTION FACTOR (dB/m)
1	#5605.60	59.0 PK	68.2	-9.2	1.33 V	229	53.00	6.00
2	*5745.00	124.4 PK			1.33 V	229	84.00	40.40
3	*5745.00	113.7 AV			1.33 V	229	73.30	40.40
4	#5956.00	58.9 PK	68.2	-9.3	1.33 V	229	52.20	6.70
5	11490.00	60.3 PK	74.0	-13.7	1.00 V	187	41.00	19.30
6	11490.00	47.2 AV	54.0	-6.8	1.00 V	187	27.90	19.30

REMARKS:

1. Emission Level(dBuV/m) = Raw Value(dBuV) + Correction Factor(dB/m)
2. Correction Factor(dB/m) = Antenna Factor(dB/m) + Cable Factor(dB)
- Pre-Amplifier Factor(dB)
3. The other emission levels were very low against the limit.
4. Margin value = Emission Level – Limit value
5. " * ": Fundamental frequency.
6. " # ": The radiated frequency is out of the restricted band.

CHANNEL	TX Channel 157	DETECTOR FUNCTION	Peak (PK)
FREQUENCY RANGE	1GHz ~ 40GHz		Average (AV)

ANTENNA POLARITY & TEST DISTANCE: HORIZONTAL AT 3 M

NO.	FREQ. (MHz)	EMISSION LEVEL (dBuV/m)	LIMIT (dBuV/m)	MARGIN (dB)	ANTENNA HEIGHT (m)	TABLE ANGLE (Degree)	RAW VALUE (dBuV)	CORRECTION FACTOR (dB/m)
1	#5611.20	58.5 PK	68.2	-9.7	1.27 H	132	52.50	6.00
2	*5785.00	115.4 PK			1.27 H	132	74.90	40.50
3	*5785.00	105.2 AV			1.27 H	132	64.70	40.50
4	#5982.40	58.5 PK	68.2	-9.7	1.27 H	132	51.80	6.70
5	11570.00	61.0 PK	74.0	-13.0	1.00 H	118	42.00	19.00
6	11570.00	47.4 AV	54.0	-6.6	1.00 H	118	28.40	19.00

ANTENNA POLARITY & TEST DISTANCE: VERTICAL AT 3 M

NO.	FREQ. (MHz)	EMISSION LEVEL (dBuV/m)	LIMIT (dBuV/m)	MARGIN (dB)	ANTENNA HEIGHT (m)	TABLE ANGLE (Degree)	RAW VALUE (dBuV)	CORRECTION FACTOR (dB/m)
1	#5617.60	58.7 PK	68.2	-9.5	1.90 V	156	52.60	6.10
2	*5785.00	124.8 PK			1.90 V	156	84.30	40.50
3	*5785.00	114.2 AV			1.90 V	156	73.70	40.50
4	#5955.20	59.2 PK	68.2	-9.0	1.90 V	156	52.50	6.70
5	11570.00	60.6 PK	74.0	-13.4	1.10 V	177	41.60	19.00
6	11570.00	47.0 AV	54.0	-7.0	1.10 V	177	28.00	19.00

REMARKS:

1. Emission Level(dBuV/m) = Raw Value(dBuV) + Correction Factor(dB/m)
2. Correction Factor(dB/m) = Antenna Factor(dB/m) + Cable Factor(dB)
- Pre-Amplifier Factor(dB)
3. The other emission levels were very low against the limit.
4. Margin value = Emission Level – Limit value
5. " * ": Fundamental frequency.
6. " # ": The radiated frequency is out of the restricted band.

CHANNEL	TX Channel 165	DETECTOR FUNCTION	Peak (PK)
FREQUENCY RANGE	1GHz ~ 40GHz		Average (AV)

ANTENNA POLARITY & TEST DISTANCE: HORIZONTAL AT 3 M

NO.	FREQ. (MHz)	EMISSION LEVEL (dBuV/m)	LIMIT (dBuV/m)	MARGIN (dB)	ANTENNA HEIGHT (m)	TABLE ANGLE (Degree)	RAW VALUE (dBuV)	CORRECTION FACTOR (dB/m)
1	#5628.00	58.6 PK	68.2	-9.6	1.14 H	135	52.50	6.10
2	*5825.00	115.1 PK			1.14 H	135	74.50	40.60
3	*5825.00	105.3 AV			1.14 H	135	64.70	40.60
4	#5932.80	59.2 PK	68.2	-9.0	1.14 H	135	52.50	6.70
5	11650.00	60.6 PK	74.0	-13.4	1.00 H	142	42.10	18.50
6	11650.00	46.9 AV	54.0	-7.1	1.00 H	142	28.40	18.50

ANTENNA POLARITY & TEST DISTANCE: VERTICAL AT 3 M

NO.	FREQ. (MHz)	EMISSION LEVEL (dBuV/m)	LIMIT (dBuV/m)	MARGIN (dB)	ANTENNA HEIGHT (m)	TABLE ANGLE (Degree)	RAW VALUE (dBuV)	CORRECTION FACTOR (dB/m)
1	#5635.20	58.5 PK	68.2	-9.7	1.25 V	228	52.40	6.10
2	*5825.00	124.1 PK			1.25 V	228	83.50	40.60
3	*5825.00	113.9 AV			1.25 V	228	73.30	40.60
4	#5934.40	58.6 PK	68.2	-9.6	1.25 V	228	51.90	6.70
5	11650.00	59.4 PK	74.0	-14.6	1.00 V	258	40.90	18.50
6	11650.00	46.8 AV	54.0	-7.2	1.00 V	258	28.30	18.50

REMARKS:

1. Emission Level(dBuV/m) = Raw Value(dBuV) + Correction Factor(dB/m)
2. Correction Factor(dB/m) = Antenna Factor(dB/m) + Cable Factor(dB)
– Pre-Amplifier Factor(dB)
3. The other emission levels were very low against the limit.
4. Margin value = Emission Level – Limit value
5. " * ": Fundamental frequency.
6. " # ": The radiated frequency is out of the restricted band.

802.11ac (VHT20)

CHANNEL	TX Channel 36	DETECTOR FUNCTION	Peak (PK)
FREQUENCY RANGE	1GHz ~ 40GHz		Average (AV)

ANTENNA POLARITY & TEST DISTANCE: HORIZONTAL AT 3 M								
NO.	FREQ. (MHz)	EMISSION LEVEL (dBuV/m)	LIMIT (dBuV/m)	MARGIN (dB)	ANTENNA HEIGHT (m)	TABLE ANGLE (Degree)	RAW VALUE (dBuV)	CORRECTION FACTOR (dB/m)
1	5150.00	59.1 PK	74.0	-14.9	1.00 H	292	53.60	5.50
2	5150.00	47.1 AV	54.0	-6.9	1.00 H	292	41.60	5.50
3	*5180.00	107.8 PK			1.00 H	292	68.30	39.50
4	*5180.00	98.2 AV			1.00 H	292	58.70	39.50
5	#10360.00	59.0 PK	74.0	-15.0	1.18 H	74	41.50	17.50
6	#10360.00	45.6 AV	54.0	-8.4	1.18 H	74	28.10	17.50

ANTENNA POLARITY & TEST DISTANCE: VERTICAL AT 3 M								
NO.	FREQ. (MHz)	EMISSION LEVEL (dBuV/m)	LIMIT (dBuV/m)	MARGIN (dB)	ANTENNA HEIGHT (m)	TABLE ANGLE (Degree)	RAW VALUE (dBuV)	CORRECTION FACTOR (dB/m)
1	5150.00	67.9 PK	74.0	-6.1	1.12 V	168	62.40	5.50
2	5150.00	53.6 AV	54.0	-0.4	1.12 V	168	48.10	5.50
3	*5180.00	116.1 PK			1.12 V	168	76.60	39.50
4	*5180.00	105.4 AV			1.12 V	168	65.90	39.50
5	#10360.00	60.5 PK	74.0	-13.5	1.25 V	87	43.00	17.50
6	#10360.00	47.9 AV	54.0	-6.1	1.25 V	87	30.40	17.50

REMARKS:

1. Emission Level(dBuV/m) = Raw Value(dBuV) + Correction Factor(dB/m)
2. Correction Factor(dB/m) = Antenna Factor(dB/m) + Cable Factor(dB)
– Pre-Amplifier Factor(dB)
3. The other emission levels were very low against the limit.
4. Margin value = Emission Level – Limit value
5. " * ": Fundamental frequency.
6. " # ": The radiated frequency is out of the restricted band.

CHANNEL	TX Channel 40	DETECTOR FUNCTION	Peak (PK)
FREQUENCY RANGE	1GHz ~ 40GHz		Average (AV)

ANTENNA POLARITY & TEST DISTANCE: HORIZONTAL AT 3 M

NO.	FREQ. (MHz)	EMISSION LEVEL (dBuV/m)	LIMIT (dBuV/m)	MARGIN (dB)	ANTENNA HEIGHT (m)	TABLE ANGLE (Degree)	RAW VALUE (dBuV)	CORRECTION FACTOR (dB/m)
1	5150.00	58.5 PK	74.0	-15.5	1.03 H	301	53.00	5.50
2	5150.00	47.1 AV	54.0	-6.9	1.03 H	301	41.60	5.50
3	*5200.00	109.6 PK			1.03 H	301	70.00	39.60
4	*5200.00	100.2 AV			1.03 H	301	60.60	39.60
5	#10400.00	59.9 PK	74.0	-14.1	1.36 H	98	41.90	18.00
6	#10400.00	46.5 AV	54.0	-7.5	1.36 H	98	28.50	18.00

ANTENNA POLARITY & TEST DISTANCE: VERTICAL AT 3 M

NO.	FREQ. (MHz)	EMISSION LEVEL (dBuV/m)	LIMIT (dBuV/m)	MARGIN (dB)	ANTENNA HEIGHT (m)	TABLE ANGLE (Degree)	RAW VALUE (dBuV)	CORRECTION FACTOR (dB/m)
1	5150.00	67.6 PK	74.0	-6.4	1.00 V	17	62.10	5.50
2	5150.00	53.6 AV	54.0	-0.4	1.00 V	17	48.10	5.50
3	*5200.00	121.2 PK			1.00 V	17	81.60	39.60
4	*5200.00	109.9 AV			1.00 V	17	70.30	39.60
5	#10400.00	59.8 PK	74.0	-14.2	1.10 V	56	41.80	18.00
6	#10400.00	47.9 AV	54.0	-6.1	1.10 V	56	29.90	18.00

REMARKS:

1. Emission Level(dBuV/m) = Raw Value(dBuV) + Correction Factor(dB/m)
2. Correction Factor(dB/m) = Antenna Factor(dB/m) + Cable Factor(dB)
– Pre-Amplifier Factor(dB)
3. The other emission levels were very low against the limit.
4. Margin value = Emission Level – Limit value
5. " * ": Fundamental frequency.
6. " # ": The radiated frequency is out of the restricted band.

CHANNEL	TX Channel 48	DETECTOR FUNCTION	Peak (PK)
FREQUENCY RANGE	1GHz ~ 40GHz		Average (AV)

ANTENNA POLARITY & TEST DISTANCE: HORIZONTAL AT 3 M

NO.	FREQ. (MHz)	EMISSION LEVEL (dBuV/m)	LIMIT (dBuV/m)	MARGIN (dB)	ANTENNA HEIGHT (m)	TABLE ANGLE (Degree)	RAW VALUE (dBuV)	CORRECTION FACTOR (dB/m)
1	*5240.00	109.9 PK			1.00 H	300	70.30	39.60
2	*5240.00	99.9 AV			1.00 H	300	60.30	39.60
3	5350.00	57.6 PK	74.0	-16.4	1.00 H	300	51.90	5.70
4	5350.00	45.2 AV	54.0	-8.8	1.00 H	300	39.50	5.70
5	#10480.00	59.2 PK	74.0	-14.8	1.17 H	41	41.20	18.00
6	#10480.00	46.8 AV	54.0	-7.2	1.17 H	41	28.80	18.00

ANTENNA POLARITY & TEST DISTANCE: VERTICAL AT 3 M

NO.	FREQ. (MHz)	EMISSION LEVEL (dBuV/m)	LIMIT (dBuV/m)	MARGIN (dB)	ANTENNA HEIGHT (m)	TABLE ANGLE (Degree)	RAW VALUE (dBuV)	CORRECTION FACTOR (dB/m)
1	*5240.00	121.6 PK			1.70 V	155	82.00	39.60
2	*5240.00	110.7 AV			1.70 V	155	71.10	39.60
3	5350.00	59.2 PK	74.0	-14.8	1.70 V	155	53.50	5.70
4	5350.00	46.9 AV	54.0	-7.1	1.70 V	155	41.20	5.70
5	#10480.00	60.7 PK	74.0	-13.3	1.10 V	113	42.70	18.00
6	#10480.00	48.1 AV	54.0	-5.9	1.10 V	113	30.10	18.00

REMARKS:

1. Emission Level(dBuV/m) = Raw Value(dBuV) + Correction Factor(dB/m)
2. Correction Factor(dB/m) = Antenna Factor(dB/m) + Cable Factor(dB)
– Pre-Amplifier Factor(dB)
3. The other emission levels were very low against the limit.
4. Margin value = Emission Level – Limit value
5. " * ": Fundamental frequency.
6. " # ": The radiated frequency is out of the restricted band.

CHANNEL	TX Channel 149	DETECTOR FUNCTION	Peak (PK)
FREQUENCY RANGE	1GHz ~ 40GHz		Average (AV)

ANTENNA POLARITY & TEST DISTANCE: HORIZONTAL AT 3 M

NO.	FREQ. (MHz)	EMISSION LEVEL (dBuV/m)	LIMIT (dBuV/m)	MARGIN (dB)	ANTENNA HEIGHT (m)	TABLE ANGLE (Degree)	RAW VALUE (dBuV)	CORRECTION FACTOR (dB/m)
1	#5604.80	58.7 PK	68.2	-9.5	1.22 H	133	52.80	5.90
2	*5745.00	115.7 PK			1.22 H	133	75.30	40.40
3	*5745.00	105.3 AV			1.22 H	133	64.90	40.40
4	#5937.60	59.7 PK	68.2	-8.5	1.22 H	133	53.00	6.70
5	11490.00	61.3 PK	74.0	-12.7	1.00 H	127	42.00	19.30
6	11490.00	47.5 AV	54.0	-6.5	1.00 H	127	28.20	19.30

ANTENNA POLARITY & TEST DISTANCE: VERTICAL AT 3 M

NO.	FREQ. (MHz)	EMISSION LEVEL (dBuV/m)	LIMIT (dBuV/m)	MARGIN (dB)	ANTENNA HEIGHT (m)	TABLE ANGLE (Degree)	RAW VALUE (dBuV)	CORRECTION FACTOR (dB/m)
1	#5628.80	59.1 PK	68.2	-9.1	1.17 V	174	53.00	6.10
2	*5745.00	123.0 PK			1.17 V	174	82.60	40.40
3	*5745.00	112.1 AV			1.17 V	174	71.70	40.40
4	#5982.40	59.6 PK	68.2	-8.6	1.17 V	174	52.90	6.70
5	11490.00	60.6 PK	74.0	-13.4	1.00 V	155	41.30	19.30
6	11490.00	47.5 AV	54.0	-6.5	1.00 V	155	28.20	19.30

REMARKS:

1. Emission Level(dBuV/m) = Raw Value(dBuV) + Correction Factor(dB/m)
2. Correction Factor(dB/m) = Antenna Factor(dB/m) + Cable Factor(dB)
- Pre-Amplifier Factor(dB)
3. The other emission levels were very low against the limit.
4. Margin value = Emission Level – Limit value
5. " * ": Fundamental frequency.
6. " # ": The radiated frequency is out of the restricted band.

CHANNEL	TX Channel 157	DETECTOR FUNCTION	Peak (PK)
FREQUENCY RANGE	1GHz ~ 40GHz		Average (AV)

ANTENNA POLARITY & TEST DISTANCE: HORIZONTAL AT 3 M

NO.	FREQ. (MHz)	EMISSION LEVEL (dBuV/m)	LIMIT (dBuV/m)	MARGIN (dB)	ANTENNA HEIGHT (m)	TABLE ANGLE (Degree)	RAW VALUE (dBuV)	CORRECTION FACTOR (dB/m)
1	#5644.80	58.4 PK	68.2	-9.8	1.28 H	133	52.30	6.10
2	*5785.00	115.0 PK			1.28 H	133	74.50	40.50
3	*5785.00	104.9 AV			1.28 H	133	64.40	40.50
4	#5954.40	59.6 PK	68.2	-8.6	1.28 H	133	52.90	6.70
5	11570.00	60.7 PK	74.0	-13.3	1.00 H	139	41.70	19.00
6	11570.00	47.4 AV	54.0	-6.6	1.00 H	139	28.40	19.00

ANTENNA POLARITY & TEST DISTANCE: VERTICAL AT 3 M

NO.	FREQ. (MHz)	EMISSION LEVEL (dBuV/m)	LIMIT (dBuV/m)	MARGIN (dB)	ANTENNA HEIGHT (m)	TABLE ANGLE (Degree)	RAW VALUE (dBuV)	CORRECTION FACTOR (dB/m)
1	#5629.60	59.0 PK	68.2	-9.2	1.30 V	229	52.90	6.10
2	*5785.00	122.9 PK			1.30 V	229	82.40	40.50
3	*5785.00	112.3 AV			1.30 V	229	71.80	40.50
4	#5964.00	60.2 PK	68.2	-8.0	1.30 V	229	53.50	6.70
5	11570.00	60.2 PK	74.0	-13.8	1.00 V	201	41.20	19.00
6	11570.00	47.0 AV	54.0	-7.0	1.00 V	201	28.00	19.00

REMARKS:

1. Emission Level(dBuV/m) = Raw Value(dBuV) + Correction Factor(dB/m)
2. Correction Factor(dB/m) = Antenna Factor(dB/m) + Cable Factor(dB)
- Pre-Amplifier Factor(dB)
3. The other emission levels were very low against the limit.
4. Margin value = Emission Level – Limit value
5. " * ": Fundamental frequency.

CHANNEL	TX Channel 165	DETECTOR FUNCTION	Peak (PK)
FREQUENCY RANGE	1GHz ~ 40GHz		Average (AV)

ANTENNA POLARITY & TEST DISTANCE: HORIZONTAL AT 3 M

NO.	FREQ. (MHz)	EMISSION LEVEL (dBuV/m)	LIMIT (dBuV/m)	MARGIN (dB)	ANTENNA HEIGHT (m)	TABLE ANGLE (Degree)	RAW VALUE (dBuV)	CORRECTION FACTOR (dB/m)
1	#5640.00	59.1 PK	68.2	-9.1	1.17 H	134	53.00	6.10
2	*5825.00	115.2 PK			1.17 H	134	74.60	40.60
3	*5825.00	104.9 AV			1.17 H	134	64.30	40.60
4	#5981.60	59.4 PK	68.2	-8.8	1.17 H	134	52.70	6.70
5	11650.00	59.7 PK	74.0	-14.3	1.00 H	119	41.20	18.50
6	11650.00	46.3 AV	54.0	-7.7	1.00 H	119	27.80	18.50

ANTENNA POLARITY & TEST DISTANCE: VERTICAL AT 3 M

NO.	FREQ. (MHz)	EMISSION LEVEL (dBuV/m)	LIMIT (dBuV/m)	MARGIN (dB)	ANTENNA HEIGHT (m)	TABLE ANGLE (Degree)	RAW VALUE (dBuV)	CORRECTION FACTOR (dB/m)
1	#5608.80	58.6 PK	68.2	-9.6	1.42 V	233	52.60	6.00
2	*5825.00	124.6 PK			1.42 V	233	84.00	40.60
3	*5825.00	113.6 AV			1.42 V	233	73.00	40.60
4	#5990.40	59.1 PK	68.2	-9.1	1.42 V	233	52.40	6.70
5	11650.00	60.0 PK	74.0	-14.0	1.00 V	254	41.50	18.50
6	11650.00	47.0 AV	54.0	-7.0	1.00 V	254	28.50	18.50

REMARKS:

1. Emission Level(dBuV/m) = Raw Value(dBuV) + Correction Factor(dB/m)
2. Correction Factor(dB/m) = Antenna Factor(dB/m) + Cable Factor(dB)
– Pre-Amplifier Factor(dB)
3. The other emission levels were very low against the limit.
4. Margin value = Emission Level – Limit value
5. " * ": Fundamental frequency.
6. " # ": The radiated frequency is out of the restricted band.

802.11ac (VHT40)

CHANNEL	TX Channel 38	DETECTOR FUNCTION	Peak (PK)
FREQUENCY RANGE	1GHz ~ 40GHz		Average (AV)

ANTENNA POLARITY & TEST DISTANCE: HORIZONTAL AT 3 M

NO.	FREQ. (MHz)	EMISSION LEVEL (dBuV/m)	LIMIT (dBuV/m)	MARGIN (dB)	ANTENNA HEIGHT (m)	TABLE ANGLE (Degree)	RAW VALUE (dBuV)	CORRECTION FACTOR (dB/m)
1	5150.00	59.5 PK	74.0	-14.5	1.00 H	295	54.00	5.50
2	5150.00	47.1 AV	54.0	-6.9	1.00 H	295	41.60	5.50
3	*5190.00	101.5 PK			1.00 H	295	62.00	39.50
4	*5190.00	92.1 AV			1.00 H	295	52.60	39.50
5	#10380.00	59.3 PK	74.0	-14.7	1.09 H	64	41.50	17.80
6	#10380.00	46.2 AV	54.0	-7.8	1.09 H	64	28.40	17.80

ANTENNA POLARITY & TEST DISTANCE: VERTICAL AT 3 M

NO.	FREQ. (MHz)	EMISSION LEVEL (dBuV/m)	LIMIT (dBuV/m)	MARGIN (dB)	ANTENNA HEIGHT (m)	TABLE ANGLE (Degree)	RAW VALUE (dBuV)	CORRECTION FACTOR (dB/m)
1	5150.00	68.0 PK	74.0	-6.0	1.11 V	180	62.50	5.50
2	5150.00	53.5 AV	54.0	-0.5	1.11 V	180	48.00	5.50
3	*5190.00	111.2 PK			1.11 V	180	71.70	39.50
4	*5190.00	101.2 AV			1.11 V	180	61.70	39.50
5	#10380.00	60.4 PK	74.0	-13.6	1.18 V	64	42.60	17.80
6	#10380.00	48.2 AV	54.0	-5.8	1.18 V	64	30.40	17.80

REMARKS:

1. Emission Level(dBuV/m) = Raw Value(dBuV) + Correction Factor(dB/m)
2. Correction Factor(dB/m) = Antenna Factor(dB/m) + Cable Factor(dB)
– Pre-Amplifier Factor(dB)
3. The other emission levels were very low against the limit.
4. Margin value = Emission Level – Limit value
5. " * ": Fundamental frequency.
6. " # ": The radiated frequency is out of the restricted band.

CHANNEL	TX Channel 46	DETECTOR FUNCTION	Peak (PK)
FREQUENCY RANGE	1GHz ~ 40GHz		Average (AV)

ANTENNA POLARITY & TEST DISTANCE: HORIZONTAL AT 3 M

NO.	FREQ. (MHz)	EMISSION LEVEL (dBuV/m)	LIMIT (dBuV/m)	MARGIN (dB)	ANTENNA HEIGHT (m)	TABLE ANGLE (Degree)	RAW VALUE (dBuV)	CORRECTION FACTOR (dB/m)
1	5150.00	59.2 PK	74.0	-14.8	1.46 H	322	53.70	5.50
2	5150.00	46.5 AV	54.0	-7.5	1.46 H	322	41.00	5.50
3	*5230.00	107.3 PK			1.46 H	322	67.70	39.60
4	*5230.00	97.6 AV			1.46 H	322	58.00	39.60
5	#10460.00	59.4 PK	74.0	-14.6	1.00 H	39	41.40	18.00
6	#10460.00	46.3 AV	54.0	-7.7	1.00 H	39	28.30	18.00

ANTENNA POLARITY & TEST DISTANCE: VERTICAL AT 3 M

NO.	FREQ. (MHz)	EMISSION LEVEL (dBuV/m)	LIMIT (dBuV/m)	MARGIN (dB)	ANTENNA HEIGHT (m)	TABLE ANGLE (Degree)	RAW VALUE (dBuV)	CORRECTION FACTOR (dB/m)
1	5150.00	68.4 PK	74.0	-5.6	1.55 V	331	62.90	5.50
2	5150.00	53.9 AV	54.0	-0.1	1.55 V	331	48.40	5.50
3	*5230.00	117.2 PK			1.55 V	331	77.60	39.60
4	*5230.00	107.5 AV			1.55 V	331	67.90	39.60
5	#10460.00	60.4 PK	74.0	-13.6	1.08 V	289	42.40	18.00
6	#10460.00	48.2 AV	54.0	-5.8	1.08 V	289	30.20	18.00

REMARKS:

- Emission Level(dBuV/m) = Raw Value(dBuV) + Correction Factor(dB/m)
- Correction Factor(dB/m) = Antenna Factor(dB/m) + Cable Factor(dB)
– Pre-Amplifier Factor(dB)
- The other emission levels were very low against the limit.
- Margin value = Emission Level – Limit value
- " * ": Fundamental frequency.
- " # ": The radiated frequency is out of the restricted band.

CHANNEL	TX Channel 151	DETECTOR FUNCTION	Peak (PK)
FREQUENCY RANGE	1GHz ~ 40GHz		Average (AV)

ANTENNA POLARITY & TEST DISTANCE: HORIZONTAL AT 3 M

NO.	FREQ. (MHz)	EMISSION LEVEL (dBuV/m)	LIMIT (dBuV/m)	MARGIN (dB)	ANTENNA HEIGHT (m)	TABLE ANGLE (Degree)	RAW VALUE (dBuV)	CORRECTION FACTOR (dB/m)
1	#5643.20	58.8 PK	68.2	-9.4	1.19 H	134	52.70	6.10
2	*5755.00	113.0 PK			1.19 H	134	72.50	40.50
3	*5755.00	103.3 AV			1.19 H	134	62.80	40.50
4	#5934.40	59.6 PK	68.2	-8.6	1.19 H	134	52.90	6.70
5	11510.00	60.6 PK	74.0	-13.4	1.00 H	91	41.50	19.10
6	11510.00	47.5 AV	54.0	-6.5	1.00 H	91	28.40	19.10

ANTENNA POLARITY & TEST DISTANCE: VERTICAL AT 3 M

NO.	FREQ. (MHz)	EMISSION LEVEL (dBuV/m)	LIMIT (dBuV/m)	MARGIN (dB)	ANTENNA HEIGHT (m)	TABLE ANGLE (Degree)	RAW VALUE (dBuV)	CORRECTION FACTOR (dB/m)
1	#5642.40	58.9 PK	68.2	-9.3	1.93 V	176	52.80	6.10
2	*5755.00	120.7 PK			1.93 V	176	80.20	40.50
3	*5755.00	110.7 AV			1.93 V	176	70.20	40.50
4	#5945.60	58.4 PK	68.2	-9.8	1.93 V	176	51.70	6.70
5	11510.00	60.0 PK	74.0	-14.0	1.00 V	121	40.90	19.10
6	11510.00	47.7 AV	54.0	-6.3	1.00 V	121	28.60	19.10

REMARKS:

1. Emission Level(dBuV/m) = Raw Value(dBuV) + Correction Factor(dB/m)
2. Correction Factor(dB/m) = Antenna Factor(dB/m) + Cable Factor(dB)
– Pre-Amplifier Factor(dB)
3. The other emission levels were very low against the limit.
4. Margin value = Emission Level – Limit value
5. " * ": Fundamental frequency.
6. " # ": The radiated frequency is out of the restricted band.

CHANNEL	TX Channel 159	DETECTOR FUNCTION	Peak (PK)
FREQUENCY RANGE	1GHz ~ 40GHz		Average (AV)

ANTENNA POLARITY & TEST DISTANCE: HORIZONTAL AT 3 M

NO.	FREQ. (MHz)	EMISSION LEVEL (dBuV/m)	LIMIT (dBuV/m)	MARGIN (dB)	ANTENNA HEIGHT (m)	TABLE ANGLE (Degree)	RAW VALUE (dBuV)	CORRECTION FACTOR (dB/m)
1	#5627.20	58.8 PK	68.2	-9.4	1.38 H	125	52.70	6.10
2	*5795.00	113.6 PK			1.38 H	125	73.10	40.50
3	*5795.00	103.6 AV			1.38 H	125	63.10	40.50
4	#5955.20	59.1 PK	68.2	-9.1	1.38 H	125	52.40	6.70
5	11590.00	60.4 PK	74.0	-13.6	1.00 H	99	41.70	18.70
6	11590.00	47.3 AV	54.0	-6.7	1.00 H	99	28.60	18.70

ANTENNA POLARITY & TEST DISTANCE: VERTICAL AT 3 M

NO.	FREQ. (MHz)	EMISSION LEVEL (dBuV/m)	LIMIT (dBuV/m)	MARGIN (dB)	ANTENNA HEIGHT (m)	TABLE ANGLE (Degree)	RAW VALUE (dBuV)	CORRECTION FACTOR (dB/m)
1	#5638.40	58.1 PK	68.2	-10.1	1.74 V	162	52.00	6.10
2	*5795.00	120.6 PK			1.74 V	162	80.10	40.50
3	*5795.00	110.8 AV			1.74 V	162	70.30	40.50
4	#5932.00	58.9 PK	68.2	-9.3	1.74 V	162	52.20	6.70
5	11590.00	59.9 PK	74.0	-14.1	1.10 V	144	41.20	18.70
6	11590.00	47.4 AV	54.0	-6.6	1.10 V	144	28.70	18.70

REMARKS:

1. Emission Level(dBuV/m) = Raw Value(dBuV) + Correction Factor(dB/m)
2. Correction Factor(dB/m) = Antenna Factor(dB/m) + Cable Factor(dB)
- Pre-Amplifier Factor(dB)
3. The other emission levels were very low against the limit.
4. Margin value = Emission Level – Limit value
5. " * ": Fundamental frequency.
6. " # ": The radiated frequency is out of the restricted band.

802.11ac (VHT80)

CHANNEL	TX Channel 42	DETECTOR FUNCTION	Peak (PK)
FREQUENCY RANGE	1GHz ~ 40GHz		Average (AV)

ANTENNA POLARITY & TEST DISTANCE: HORIZONTAL AT 3 M								
NO.	FREQ. (MHz)	EMISSION LEVEL (dBuV/m)	LIMIT (dBuV/m)	MARGIN (dB)	ANTENNA HEIGHT (m)	TABLE ANGLE (Degree)	RAW VALUE (dBuV)	CORRECTION FACTOR (dB/m)
1	5150.00	57.1 PK	74.0	-16.9	1.09 H	293	51.60	5.50
2	5150.00	44.3 AV	54.0	-9.7	1.09 H	293	38.80	5.50
3	*5210.00	96.1 PK			1.09 H	293	56.50	39.60
4	*5210.00	86.3 AV			1.09 H	293	46.70	39.60
5	#10420.00	59.1 PK	74.0	-14.9	1.00 H	36	41.10	18.00
6	#10420.00	46.0 AV	54.0	-8.0	1.00 H	36	28.00	18.00

ANTENNA POLARITY & TEST DISTANCE: VERTICAL AT 3 M								
NO.	FREQ. (MHz)	EMISSION LEVEL (dBuV/m)	LIMIT (dBuV/m)	MARGIN (dB)	ANTENNA HEIGHT (m)	TABLE ANGLE (Degree)	RAW VALUE (dBuV)	CORRECTION FACTOR (dB/m)
1	5150.00	68.8 PK	74.0	-5.2	1.56 V	161	63.30	5.50
2	5150.00	53.6 AV	54.0	-0.4	1.56 V	161	48.10	5.50
3	*5210.00	108.7 PK			1.56 V	161	69.10	39.60
4	*5210.00	98.6 AV			1.56 V	161	59.00	39.60
5	#10420.00	60.0 PK	74.0	-14.0	1.10 V	68	42.00	18.00
6	#10420.00	47.9 AV	54.0	-6.1	1.10 V	68	29.90	18.00

REMARKS:

1. Emission Level(dBuV/m) = Raw Value(dBuV) + Correction Factor(dB/m)
2. Correction Factor(dB/m) = Antenna Factor(dB/m) + Cable Factor(dB)
– Pre-Amplifier Factor(dB)
3. The other emission levels were very low against the limit.
4. Margin value = Emission Level – Limit value
5. " * ": Fundamental frequency.
6. " # ": The radiated frequency is out of the restricted band.

CHANNEL	TX Channel 155	DETECTOR FUNCTION	Peak (PK)
FREQUENCY RANGE	1GHz ~ 40GHz		Average (AV)

ANTENNA POLARITY & TEST DISTANCE: HORIZONTAL AT 3 M

NO.	FREQ. (MHz)	EMISSION LEVEL (dBuV/m)	LIMIT (dBuV/m)	MARGIN (dB)	ANTENNA HEIGHT (m)	TABLE ANGLE (Degree)	RAW VALUE (dBuV)	CORRECTION FACTOR (dB/m)
1	#5643.20	59.9 PK	68.2	-8.3	1.27 H	133	53.80	6.10
2	*5775.00	109.5 PK			1.27 H	133	69.00	40.50
3	*5775.00	100.4 AV			1.27 H	133	59.90	40.50
4	#5962.40	59.3 PK	68.2	-8.9	1.27 H	133	52.60	6.70
5	11550.00	61.1 PK	74.0	-12.9	1.00 H	157	42.10	19.00
6	11550.00	47.6 AV	54.0	-6.4	1.00 H	157	28.60	19.00

ANTENNA POLARITY & TEST DISTANCE: VERTICAL AT 3 M

NO.	FREQ. (MHz)	EMISSION LEVEL (dBuV/m)	LIMIT (dBuV/m)	MARGIN (dB)	ANTENNA HEIGHT (m)	TABLE ANGLE (Degree)	RAW VALUE (dBuV)	CORRECTION FACTOR (dB/m)
1	#5632.80	65.8 PK	68.2	-2.4	1.39 V	229	59.70	6.10
2	#5652.80	69.9 PK	70.3	-0.4	1.39 V	229	63.80	6.10
3	*5775.00	117.8 PK			1.39 V	229	77.30	40.50
4	*5775.00	107.7 AV			1.39 V	229	67.20	40.50
5	#5932.00	62.4 PK	68.2	-5.8	1.39 V	229	55.70	6.70
6	11550.00	60.3 PK	74.0	-13.7	1.00 V	205	41.30	19.00
7	11550.00	47.6 AV	54.0	-6.4	1.00 V	205	28.60	19.00

REMARKS:

1. Emission Level(dBuV/m) = Raw Value(dBuV) + Correction Factor(dB/m)
2. Correction Factor(dB/m) = Antenna Factor(dB/m) + Cable Factor(dB)
- Pre-Amplifier Factor(dB)
3. The other emission levels were very low against the limit.
4. Margin value = Emission Level – Limit value
5. " * ": Fundamental frequency.
6. " # ": The radiated frequency is out of the restricted band.

Below 1GHz Worst-Case Data: 802.11a

CHANNEL	TX Channel 149	DETECTOR FUNCTION	Quasi-Peak (QP)
FREQUENCY RANGE	30MHz ~ 1GHz	TEST MODE	B

ANTENNA POLARITY & TEST DISTANCE: HORIZONTAL AT 3 M								
NO.	FREQ. (MHz)	EMISSION LEVEL (dBuV/m)	LIMIT (dBuV/m)	MARGIN (dB)	ANTENNA HEIGHT (m)	TABLE ANGLE (Degree)	RAW VALUE (dBuV)	CORRECTION FACTOR (dB/m)
1	124.98	31.4 QP	43.5	-12.1	1.99 H	226	47.20	-15.80
2	249.17	31.0 QP	46.0	-15.0	1.24 H	298	45.60	-14.60
3	454.85	30.5 QP	46.0	-15.5	1.99 H	285	40.70	-10.20
4	577.09	28.0 QP	46.0	-18.0	1.50 H	234	35.90	-7.90
5	755.61	30.9 QP	46.0	-15.1	1.00 H	176	34.70	-3.80
6	961.29	40.6 QP	54.0	-13.4	1.24 H	222	41.10	-0.50

ANTENNA POLARITY & TEST DISTANCE: VERTICAL AT 3 M								
NO.	FREQ. (MHz)	EMISSION LEVEL (dBuV/m)	LIMIT (dBuV/m)	MARGIN (dB)	ANTENNA HEIGHT (m)	TABLE ANGLE (Degree)	RAW VALUE (dBuV)	CORRECTION FACTOR (dB/m)
1	45.42	36.8 QP	40.0	-3.2	1.00 V	13	51.10	-14.30
2	124.98	32.2 QP	43.5	-11.3	1.00 V	233	48.00	-15.80
3	450.97	30.2 QP	46.0	-15.8	1.00 V	252	40.40	-10.20
4	577.09	28.4 QP	46.0	-17.6	1.00 V	119	36.30	-7.90
5	751.73	29.6 QP	46.0	-16.4	1.00 V	204	33.40	-3.80
6	961.29	41.4 QP	54.0	-12.6	1.25 V	172	41.90	-0.50

REMARKS:

1. Emission Level(dBuV/m) = Raw Value(dBuV) + Correction Factor(dB/m)
2. Correction Factor(dB/m) = Antenna Factor(dB/m) + Cable Factor(dB)
– Pre-Amplifier Factor(dB)
3. The other emission levels were very low against the limit.
4. Margin value = Emission Level – Limit value

4.2 Conducted Emission Measurement

4.2.1 Limits of Conducted Emission Measurement

Frequency (MHz)	Conducted Limit (dBuV)	
	Quasi-peak	Average
0.15 - 0.5	66 - 56	56 - 46
0.50 - 5.0	56	46
5.0 - 30.0	60	50

Note: 1. The lower limit shall apply at the transition frequencies.

2. The limit decreases in line with the logarithm of the frequency in the range of 0.15 to 0.50MHz.

4.2.2 Test Instruments

Tested date: Jul. 12 ~ Aug. 19, 2016

Description & Manufacturer	Model No.	Serial No.	Cal. Date	Cal. Due
Test Receiver ROHDE & SCHWARZ	ESCS30	100289	Dec. 23, 2015	Dec. 22, 2016
RF signal cable (with 10dB PAD) Woken	5D-FB	Cable-cond2-01	Dec. 26, 2015	Dec. 25, 2016
LISN ROHDE & SCHWARZ (EUT)	ESH2-Z5	100100	Jan. 11, 2016	Jan. 10, 2017
LISN ROHDE & SCHWARZ (Peripheral)	ESH3-Z5	100312	Jul. 21, 2015	Jul. 20, 2016
			Jul. 26, 2016	Jul. 25, 2017
Software ADT	BV ADT_Cond_ V7.3.7.3	NA	NA	NA

Note: 1. The calibration interval of the above test instruments is 12 months and the calibrations are traceable to NML/ROC and NIST/USA.

2. The test was performed in HwaYa Shielded Room 2.

3. The VCCI Site Registration No. is C-2047.

4.2.3 Test Procedure

- The EUT was placed 0.4 meters from the conducting wall of the shielded room with EUT being connected to the power mains through a line impedance stabilization network (LISN). Other support units were connected to the power mains through another LISN. The two LISNs provide 50 ohm/ 50uH of coupling impedance for the measuring instrument.
- Both lines of the power mains connected to the EUT were checked for maximum conducted interference.
- The frequency range from 150kHz to 30MHz was searched. Emission levels under (Limit - 20dB) was not recorded.

NOTE: The resolution bandwidth and video bandwidth of test receiver is 9kHz for quasi-peak detection (QP) and average detection (AV) at frequency 0.15MHz-30MHz.

4.2.4 Deviation from Test Standard

No deviation.

4.2.5 Test Setup

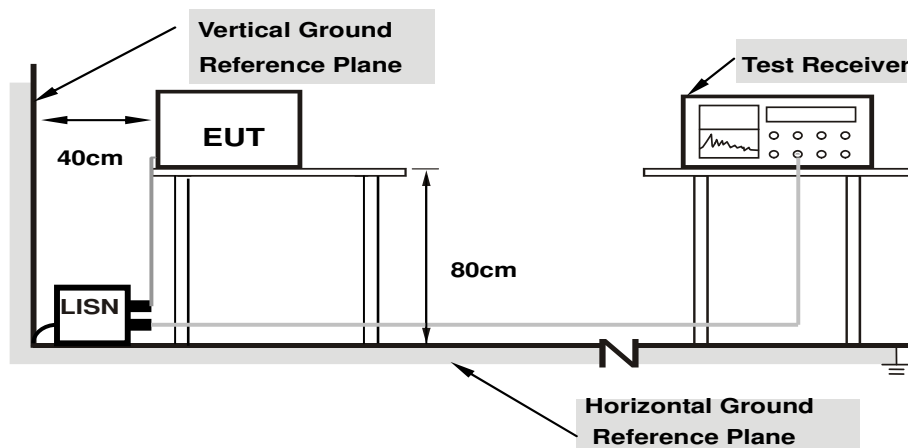

- Note:**
- Support units were connected to second LISN.
 - Both of LISNs (AMN) are 80 cm from EUT and at least 80 from other units and other metal planes

For the actual test configuration, please refer to the attached file (Test Setup Photo).

4.2.6 EUT Operating Conditions

Same as 4.1.6.

4.2.7 Test Results

Phase	Line (L)	Detector Function	Quasi-Peak (QP) / Average (AV)
Test Mode	A		

No	Freq. [MHz]	Corr. Factor (dB)	Reading Value		Emission Level		Limit		Margin	
			[dB (uV)]		[dB (uV)]		[dB (uV)]		(dB)	
			Q.P.	AV.	Q.P.	AV.	Q.P.	AV.	Q.P.	AV.
1	0.21250	10.21	26.06	11.47	36.27	21.68	63.11	53.11	-26.84	-31.43
2	0.38438	10.24	22.74	15.83	32.98	26.07	58.18	48.18	-25.20	-22.11
3	0.75938	10.28	6.20	4.82	16.48	15.10	56.00	46.00	-39.52	-30.90
4	2.61328	10.39	7.53	1.95	17.92	12.34	56.00	46.00	-38.08	-33.66
5	4.71875	10.42	12.98	6.12	23.40	16.54	56.00	46.00	-32.60	-29.46
6	11.72656	10.55	13.74	7.83	24.29	18.38	60.00	50.00	-35.71	-31.62

REMARKS:

1. Q.P. and AV. are abbreviations of quasi-peak and average individually.
2. The emission levels of other frequencies were very low against the limit.
3. Margin value = Emission level - Limit value
4. Correction factor = Insertion loss + Cable loss
5. Emission Level = Correction Factor + Reading Value.



Phase	Neutral (N)	Detector Function	Quasi-Peak (QP) / Average (AV)
Test Mode	A		

No	Freq. [MHz]	Corr. Factor (dB)	Reading Value [dB (uV)]		Emission Level [dB (uV)]		Limit [dB (uV)]		Margin (dB)	
			Q.P.	AV.	Q.P.	AV.	Q.P.	AV.	Q.P.	AV.
			1	0.22031	10.21	22.24	9.02	32.45	19.23	62.81
2	0.38047	10.29	19.34	11.96	29.63	22.25	58.27	48.27	-28.64	-26.02
3	1.04297	10.30	1.15	-3.11	11.45	7.19	56.00	46.00	-44.55	-38.81
4	4.55078	10.56	12.08	5.67	22.64	16.23	56.00	46.00	-33.36	-29.77
5	10.28516	10.62	15.21	10.19	25.83	20.81	60.00	50.00	-34.17	-29.19
6	20.65625	10.87	-0.77	-3.81	10.10	7.06	60.00	50.00	-49.90	-42.94

REMARKS:

1. Q.P. and AV. are abbreviations of quasi-peak and average individually.
2. The emission levels of other frequencies were very low against the limit.
3. Margin value = Emission level - Limit value
4. Correction factor = Insertion loss + Cable loss
5. Emission Level = Correction Factor + Reading Value.

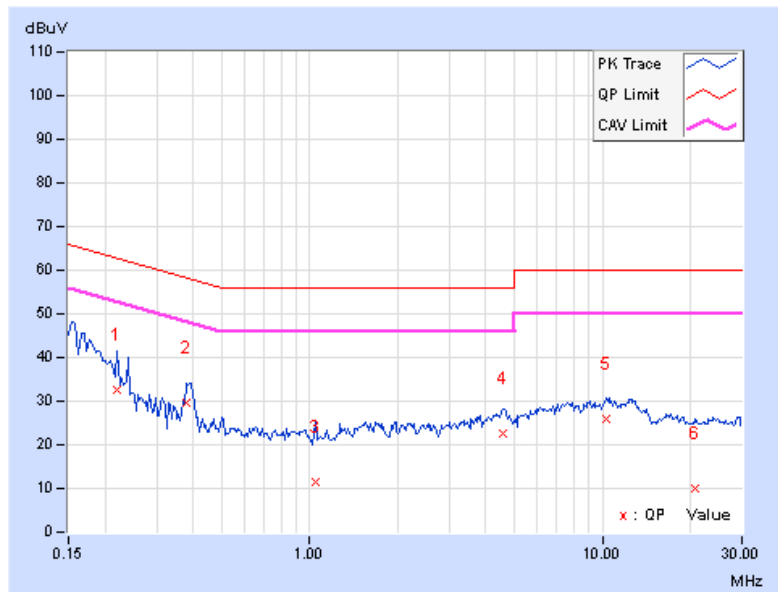

Phase	Line (L)	Detector Function	Quasi-Peak (QP) / Average (AV)
Test Mode	B		

No	Freq. [MHz]	Corr. Factor (dB)	Reading Value [dB (uV)]		Emission Level [dB (uV)]		Limit [dB (uV)]		Margin (dB)	
			Q.P.	AV.	Q.P.	AV.	Q.P.	AV.	Q.P.	AV.
			1	0.15781	10.13	39.14	21.04	49.27	31.17	65.58
2	0.21250	10.16	29.42	15.68	39.58	25.84	63.11	53.11	-23.53	-27.27
3	0.38828	10.19	21.82	12.18	32.01	22.37	58.10	48.10	-26.09	-25.73
4	1.11328	10.23	7.98	4.36	18.21	14.59	56.00	46.00	-37.79	-31.41
5	3.61328	10.34	8.40	3.62	18.74	13.96	56.00	46.00	-37.26	-32.04
6	12.17969	10.51	10.54	4.92	21.05	15.43	60.00	50.00	-38.95	-34.57

REMARKS:

1. Q.P. and AV. are abbreviations of quasi-peak and average individually.
2. The emission levels of other frequencies were very low against the limit.
3. Margin value = Emission level - Limit value
4. Correction factor = Insertion loss + Cable loss
5. Emission Level = Correction Factor + Reading Value.

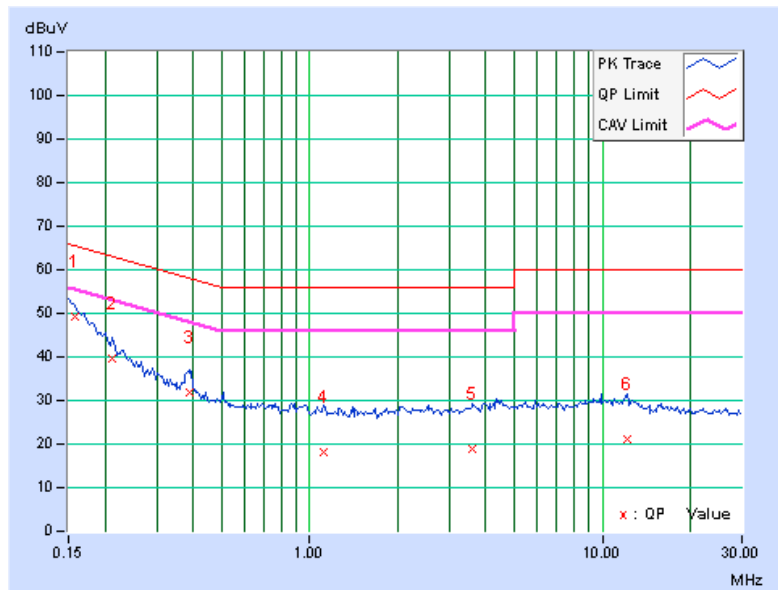

Phase	Neutral (N)	Detector Function	Quasi-Peak (QP) / Average (AV)
Test Mode	B		

No	Freq. [MHz]	Corr. Factor (dB)	Reading Value [dB (uV)]		Emission Level [dB (uV)]		Limit [dB (uV)]		Margin (dB)	
			Q.P.	AV.	Q.P.	AV.	Q.P.	AV.	Q.P.	AV.
			1	0.15391	10.13	39.56	23.06	49.69	33.19	65.79
2	0.20859	10.16	29.80	14.26	39.96	24.42	63.26	53.26	-23.30	-28.84
3	0.39219	10.19	22.50	12.42	32.69	22.61	58.02	48.02	-25.33	-25.41
4	1.34375	10.24	8.34	4.34	18.58	14.58	56.00	46.00	-37.42	-31.42
5	4.44141	10.40	9.84	4.28	20.24	14.68	56.00	46.00	-35.76	-31.32
6	12.01172	10.60	12.64	5.92	23.24	16.52	60.00	50.00	-36.76	-33.48

REMARKS:

1. Q.P. and AV. are abbreviations of quasi-peak and average individually.
2. The emission levels of other frequencies were very low against the limit.
3. Margin value = Emission level - Limit value
4. Correction factor = Insertion loss + Cable loss
5. Emission Level = Correction Factor + Reading Value.

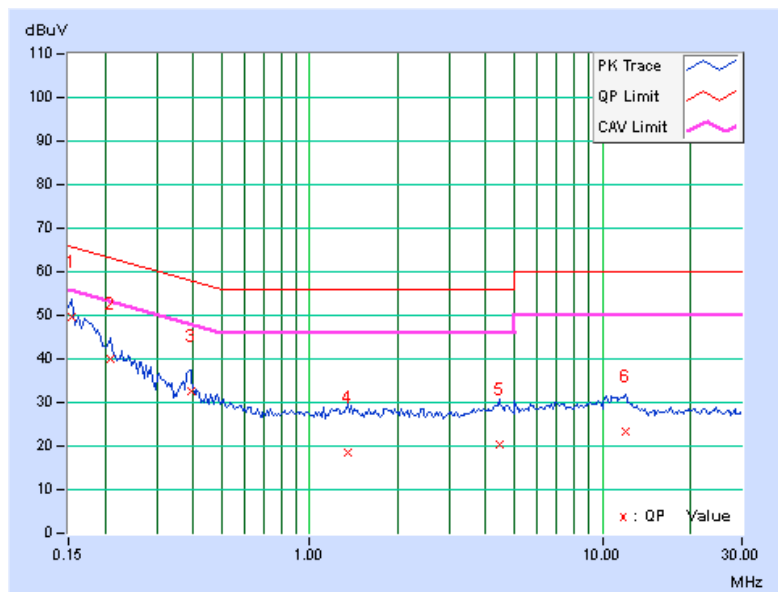

4.3 Transmit Power Measurement

4.3.1 Limits of Transmit Power Measurement

Operation Band	EUT Category		LIMIT
U-NII-1		Outdoor Access Point	1 Watt (30 dBm) (Max. e.i.r.p \leq 125mW (21 dBm) at any elevation angle above 30 degrees as measured from the horizon)
		Fixed point-to-point Access Point	1 Watt (30 dBm)
	√	Indoor Access Point	1 Watt (30 dBm)
		Mobile and Portable client device	250mW (24 dBm)
U-NII-2A	---		250mW (24 dBm) or 11 dBm+10 log B*
U-NII-2C	---		250mW (24 dBm) or 11 dBm+10 log B*
U-NII-3	√		1 Watt (30 dBm)

*B is the 26 dB emission bandwidth in megahertz

Per KDB 662911 Method of conducted output power measurement on IEEE 802.11 devices,

Array Gain = 0 dB (i.e., no array gain) for $N_{ANT} \leq 4$;

Array Gain = 0 dB (i.e., no array gain) for channel widths ≥ 40 MHz for any N_{ANT} ;

Array Gain = $5 \log(N_{ANT}/N_{SS})$ dB or 3 dB, whichever is less for 20-MHz channel widths with $N_{ANT} \geq 5$.

For power measurements on all other devices: Array Gain = $10 \log(N_{ANT}/N_{SS})$ dB.

4.3.2 Test Setup

For Power Output Measurement

For 802.11a, 802.11n (HT20), 802.11n (HT40)

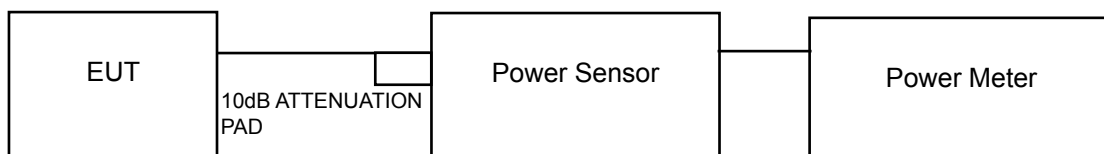

For 802.11ac (VHT80)

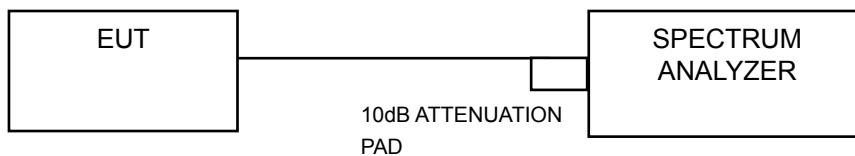

For 26dB and Occupied Bandwidth

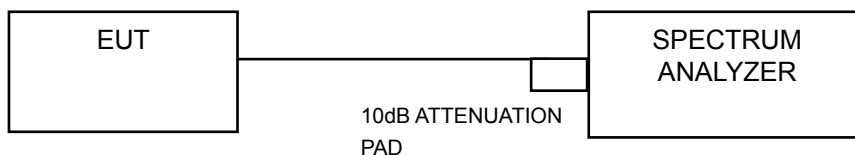

4.3.3 Test Instruments

Refer to section 4.1.2 to get information of above instrument.

4.3.4 Test Procedure

For Average Power Measurement

For 802.11a, 802.11ac (VHT20), 802.11ac (VHT40)

Method PM is used to perform output power measurement, trigger and gating function of wide band power meter is enabled to measure max output power of TX on burst. Duty factor is not added to measured value.

For 802.11ac (VHT80)

- a. Set span to encompass the entire 26 dB EBW (or, alternatively, the entire 99% occupied bandwidth) of the signal.
- b. Set sweep trigger to "free run".
- c. Set RBW = 1 MHz
- d. Set VBW \geq 3 MHz
- e. Number of points in sweep \geq 2 Span / RBW
- f. Sweep time \leq (number of points in sweep) * T
- g. Using emission bandwidth to determine the frequency span for integration the channel bandwidth.
- h. Detector = RMS
- i. Trace mode = max hold
- j. Allow max hold to run for at least 60 seconds, or longer as needed to allow the trace to stabilize.

For Occupied Bandwidth

The transmitter output was connected to the spectrum analyzer through an attenuator. The bandwidth of the fundamental frequency was measured by spectrum analyzer with resolution bandwidth in the range of 1% to 5% of the anticipated emission bandwidth, and a video bandwidth at least 3x the resolution bandwidth and set the detector to Sampling. The width of a frequency band such that, below the lower and above the upper frequency limits, the mean powers emitted are each equal to a specified percentage 0.5 %of the total mean power of a given emission.

4.3.5 Deviation from Test Standard

No deviation.

4.3.6 EUT Operating Conditions

The software provided by client to enable the EUT under transmission Condition continuously at lowest, middle and highest channel frequencies individually.

4.3.7 Test Result

Power Output:

For U-NII-1Band:

CDD Mode

802.11a

Channel	Frequency (MHz)	Maximum Conducted Power (dBm)		Total Power (mW)	Total Power (dBm)	Power Limit (dBm)	Pass / Fail
		Chain 0	Chain 1				
36	5180	22.52	22.72	365.717	25.63	30	Pass
40	5200	26.35	26.71	900.332	29.54	30	Pass
48	5240	25.32	25.63	706.003	28.49	30	Pass

802.11ac (VHT20)

Channel	Frequency (MHz)	Maximum Conducted Power (dBm)		Total Power (mW)	Total Power (dBm)	Power Limit (dBm)	Pass / Fail
		Chain 0	Chain 1				
36	5180	22.58	22.81	372.119	25.71	30	Pass
40	5200	26.31	26.67	892.078	29.50	30	Pass
48	5240	25.33	25.65	708.475	28.50	30	Pass

802.11ac (VHT40)

Channel	Frequency (MHz)	Maximum Conducted Power (dBm)		Total Power (mW)	Total Power (dBm)	Power Limit (dBm)	Pass / Fail
		Chain 0	Chain 1				
38	5190	20.85	21.23	254.358	24.05	30	Pass
46	5230	24.65	24.92	602.199	27.80	30	Pass

802.11ac (VHT80)

Channel	Frequency (MHz)	Maximum Conducted Power (dBm)		Total Power (mW)	Total Power (dBm)	Power Limit (dBm)	Pass / Fail
		Chain 0	Chain 1				
42	5210	20.82	21.09	249.31	23.97	30	Pass

Beamforming_NSS1 Mode

802.11ac (VHT20)

Channel	Frequency (MHz)	Maximum Conducted Power (dBm)		Total Power (mW)	Total Power (dBm)	Power Limit (dBm)	Pass / Fail
		Chain 0	Chain 1				
36	5180	22.47	22.69	362.384	25.59	30	Pass
40	5200	26.01	26.25	820.722	29.14	30	Pass
48	5240	25.37	25.69	715.031	28.54	30	Pass

Note: Directional gain = 5.812dBi < 6dBi, so the power limit is not reduced.

802.11ac (VHT40)

Channel	Frequency (MHz)	Maximum Conducted Power (dBm)		Total Power (mW)	Total Power (dBm)	Power Limit (dBm)	Pass / Fail
		Chain 0	Chain 1				
38	5190	20.93	21.25	257.232	24.10	30	Pass
46	5230	25.19	25.24	664.565	28.23	30	Pass

Note: Directional gain = 5.812dBi < 6dBi, so the power limit is not reduced.

802.11ac (VHT80)

Channel	Frequency (MHz)	Maximum Conducted Power (dBm)		Total Power (mW)	Total Power (dBm)	Power Limit (dBm)	Pass / Fail
		Chain 0	Chain 1				
42	5210	20.90	21.19	254.549	24.06	30	Pass

Note: Directional gain = 5.812dBi < 6dBi, so the power limit is not reduced.

For U-NII-3 Band:

CDD Mode

802.11a

Channel	Freq. (MHz)	Maximum Conducted Power (dBm)				Total Power (mW)	Total Power (dBm)	Limit (dBm)	Pass / Fail
		Chain 0	Chain 1	Chain 2	Chain 3				
149	5745	23.69	23.53	23.77	23.74	934.132	29.70	30	Pass
157	5785	23.42	23.42	23.55	23.51	890.424	29.50	30	Pass
165	5825	23.57	23.56	23.52	23.37	896.671	29.53	30	Pass

802.11ac (VHT20)

Channel	Freq. (MHz)	Maximum Conducted Power (dBm)				Total Power (mW)	Total Power (dBm)	Limit (dBm)	Pass / Fail
		Chain 0	Chain 1	Chain 2	Chain 3				
149	5745	23.63	23.27	23.59	23.47	893.890	29.51	30	Pass
157	5785	23.56	23.46	23.60	23.39	896.166	29.52	30	Pass
165	5825	23.68	23.39	23.62	23.24	892.626	29.51	30	Pass

802.11ac (VHT40)

Channel	Freq. (MHz)	Maximum Conducted Power (dBm)				Total Power (mW)	Total Power (dBm)	Limit (dBm)	Pass / Fail
		Chain 0	Chain 1	Chain 2	Chain 3				
151	5755	23.48	23.54	23.73	23.45	906.145	29.57	30	Pass
159	5795	23.61	23.53	23.75	23.39	910.449	29.59	30	Pass

802.11ac (VHT80)

Channel	Freq. (MHz)	Maximum Conducted Power (dBm)				Total Power (mW)	Total Power (dBm)	Limit (dBm)	Pass / Fail
		Chain 0	Chain 1	Chain 2	Chain 3				
155	5775	23.66	23.39	23.55	23.39	895.284	29.52	30	Pass

Beamforming_NSS1 Mode

802.11ac (VHT20)

Channel	Freq. (MHz)	Maximum Conducted Power (dBm)				Total Power (mW)	Total Power (dBm)	Limit (dBm)	Pass / Fail
		Chain 0	Chain 1	Chain 2	Chain 3				
149	5745	21.74	21.63	22.35	21.85	619.725	27.92	27.932	Pass
157	5785	21.87	21.79	22.09	21.83	619.036	27.92	27.932	Pass
165	5825	21.79	21.67	22.12	21.72	609.425	27.85	27.932	Pass

Note: Directional gain = 8.068dBi > 6dBi, so the power limit shall be reduced to $30 - (8.068 - 6) = 27.932$ dBm.

802.11ac (VHT40)

Channel	Freq. (MHz)	Maximum Conducted Power (dBm)				Total Power (mW)	Total Power (dBm)	Limit (dBm)	Pass / Fail
		Chain 0	Chain 1	Chain 2	Chain 3				
151	5755	21.81	21.84	22.01	21.92	618.914	27.92	27.932	Pass
159	5795	21.81	21.85	22.03	21.73	613.338	27.88	27.932	Pass

Note: Directional gain = 8.068dBi > 6dBi, so the power limit shall be reduced to $30 - (8.068 - 6) = 27.932$ dBm.

802.11ac (VHT80)

Channel	Freq. (MHz)	Maximum Conducted Power (dBm)				Total Power (mW)	Total Power (dBm)	Limit (dBm)	Pass / Fail
		Chain 0	Chain 1	Chain 2	Chain 3				
155	5775	21.85	21.68	22.09	21.74	611.427	27.86	27.932	Pass

Note: Directional gain = 8.068dBi > 6dBi, so the power limit shall be reduced to $30 - (8.068 - 6) = 27.932$ dBm.

Beamforming_NSS2 Mode

802.11ac (VHT20)

Channel	Freq. (MHz)	Maximum Conducted Power (dBm)				Total Power (mW)	Total Power (dBm)	Limit (dBm)	Pass / Fail
		Chain 0	Chain 1	Chain 2	Chain 3				
149	5745	23.32	23.25	23.40	23.63	875.583	29.42	30	Pass
157	5785	23.44	23.56	23.64	23.33	894.270	29.51	30	Pass
165	5825	23.41	23.26	23.61	23.62	890.875	29.50	30	Pass

Note: Directional gain = 5.058dBi < 6dBi, so the power limit no need to reduced.

802.11ac (VHT40)

Channel	Freq. (MHz)	Maximum Conducted Power (dBm)				Total Power (mW)	Total Power (dBm)	Limit (dBm)	Pass / Fail
		Chain 0	Chain 1	Chain 2	Chain 3				
151	5755	23.64	23.33	23.36	23.35	879.526	29.44	30	Pass
159	5795	23.30	23.46	23.25	23.53	872.389	29.41	30	Pass

Note: Directional gain = 5.058dBi < 6dBi, so the power limit no need to reduced.

802.11ac (VHT80)

Channel	Freq. (MHz)	Maximum Conducted Power (dBm)				Total Power (mW)	Total Power (dBm)	Limit (dBm)	Pass / Fail
		Chain 0	Chain 1	Chain 2	Chain 3				
155	5775	23.51	23.24	23.47	23.43	877.875	29.43	30	Pass

Note: Directional gain = 5.058dBi < 6dBi, so the power limit no need to reduced.

26dB Bandwidth:

CDD Mode

802.11a

Channel	Frequency (MHz)	26dBc Bandwidth (MHz)		Pass / Fail
		Chain 0	Chain 1	
36	5180	20.04	20.18	Pass
40	5200	35.15	34.63	Pass
48	5240	35.22	36.88	Pass

802.11ac (VHT20)

Channel	Frequency (MHz)	26dBc Bandwidth (MHz)		Pass / Fail
		Chain 0	Chain 1	
36	5180	20.58	29.88	Pass
40	5200	34.19	45.38	Pass
48	5240	36.45	42.06	Pass

802.11ac (VHT40)

Channel	Frequency (MHz)	26dBc Bandwidth (MHz)		Pass / Fail
		Chain 0	Chain 1	
38	5190	40.80	41.01	Pass
46	5230	75.00	84.72	Pass

802.11ac (VHT80)

Channel	Frequency (MHz)	26dBc Bandwidth (MHz)		Pass / Fail
		Chain 0	Chain 1	
42	5210	83.81	83.79	Pass

Spectrum Plot of Worst Value

802.11a

802.11ac (VHT20)

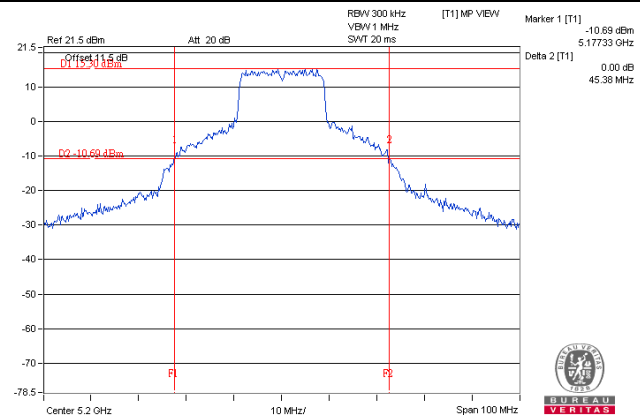
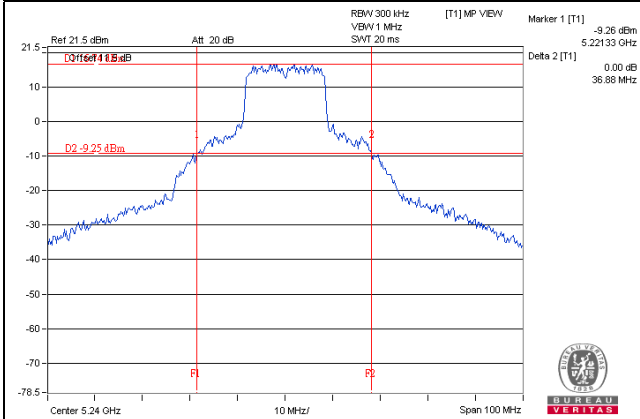

802.11ac (VHT40)

802.11ac (VHT80)

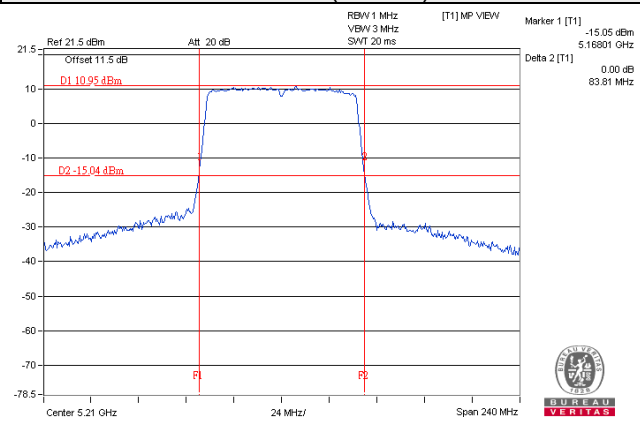
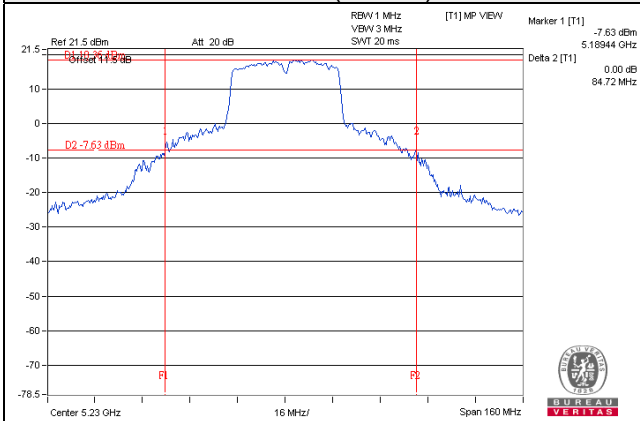

Beamforming_NSS1 Mode

802.11ac (VHT20)

Channel	Frequency (MHz)	26dBc Bandwidth (MHz)		Pass / Fail
		Chain 0	Chain 1	
36	5180	20.85	20.73	Pass
40	5200	42.77	41.69	Pass
48	5240	33.34	33.07	Pass

802.11ac (VHT40)

Channel	Frequency (MHz)	26dBc Bandwidth (MHz)		Pass / Fail
		Chain 0	Chain 1	
38	5190	41.05	40.71	Pass
46	5230	71.78	68.02	Pass

802.11ac (VHT80)

Channel	Frequency (MHz)	26dBc Bandwidth (MHz)		Pass / Fail
		Chain 0	Chain 1	
42	5210	84.34	84.17	Pass

Spectrum Plot of Worst Value

802.11ac (VHT20)

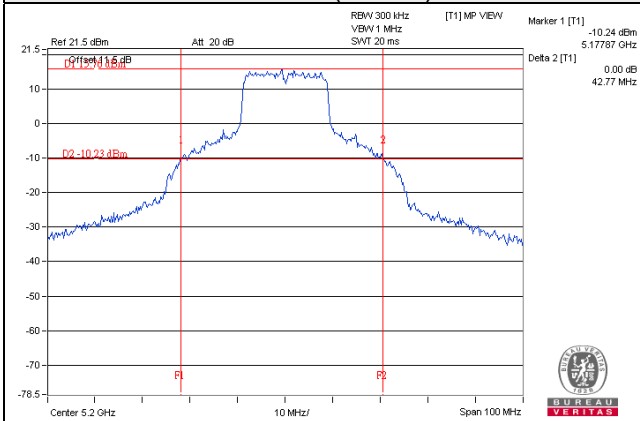

802.11ac (VHT40)

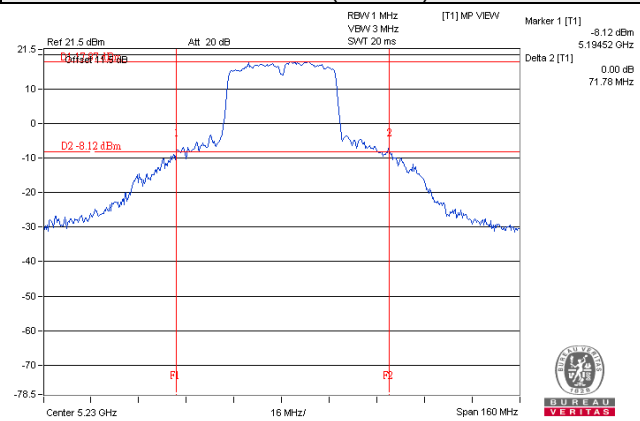

802.11ac (VHT80)

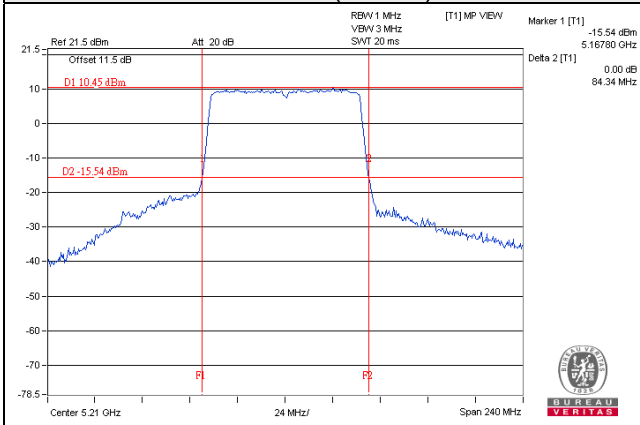

Occupied Bandwidth:
For U-NII-1Band:

CDD Mode

802.11a

Channel	Frequency (MHz)	Occupied Bandwidth (MHz)	
		Chain 0	Chain 1
36	5180	16.56	16.56
40	5200	17.16	17.16
48	5240	17.76	20.64

802.11ac (VHT20)

Channel	Frequency (MHz)	Occupied Bandwidth (MHz)	
		Chain 0	Chain 1
36	5180	17.64	17.76
40	5200	18.12	27.60
48	5240	18.48	21.60

802.11ac (VHT40)

Channel	Frequency (MHz)	Occupied Bandwidth (MHz)	
		Chain 0	Chain 1
38	5190	36.12	36.24
46	5230	36.60	37.32

802.11ac (VHT80)

Channel	Frequency (MHz)	Occupied Bandwidth (MHz)	
		Chain 0	Chain 1
42	5210	75.88	76.16

Spectrum Plot of Worst Value

802.11a

802.11ac (VHT20) Chain 1 / Ch40

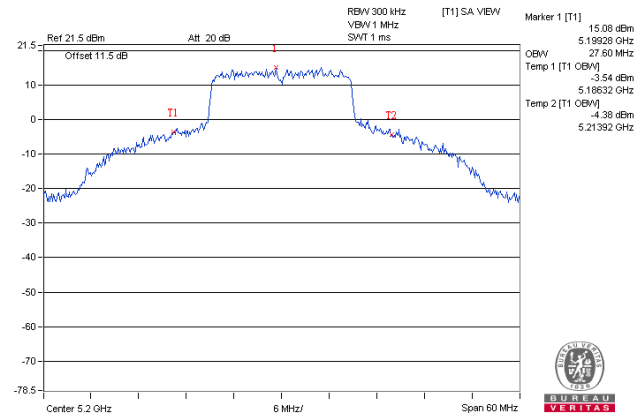
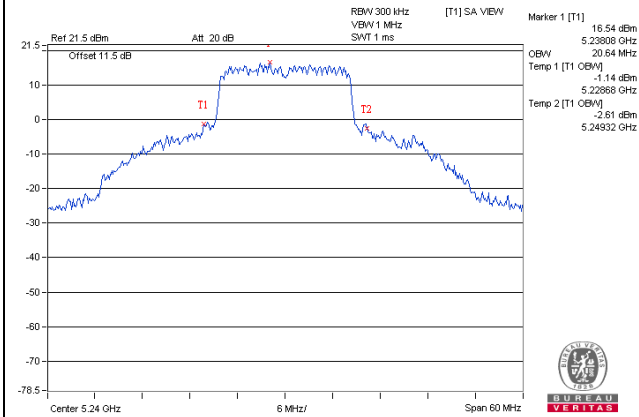

802.11ac (VHT20) Chain 1 / Ch48

802.11ac (VHT40)

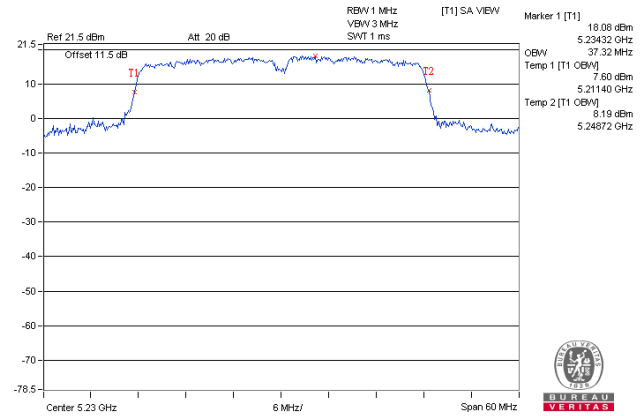
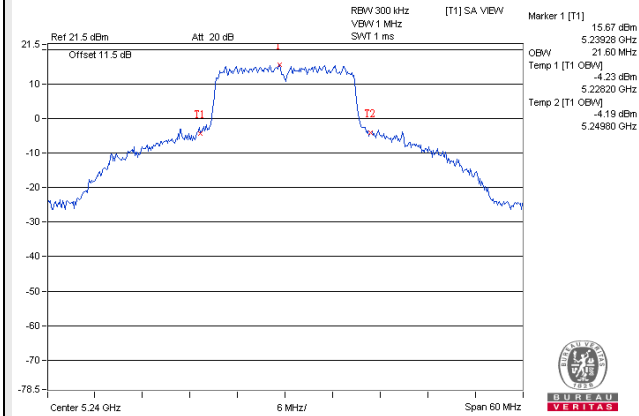

802.11ac (VHT80)

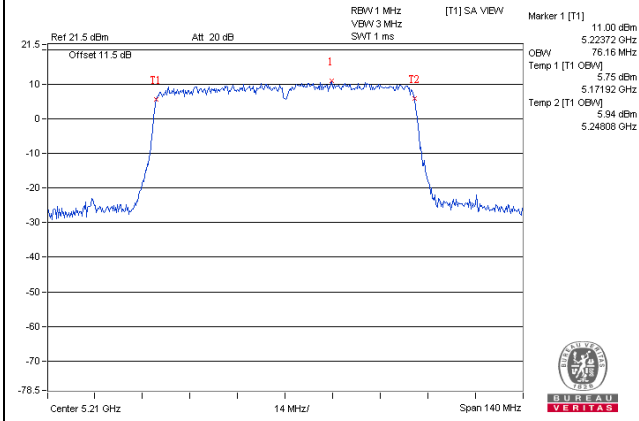

Beamforming_NSS1 Mode

802.11ac (VHT20)

Channel	Frequency (MHz)	Occupied Bandwidth (MHz)	
		Chain 0	Chain 1
36	5180	17.64	17.64
40	5200	23.52	21.00
48	5240	18.00	18.00

802.11ac (VHT40)

Channel	Frequency (MHz)	Occupied Bandwidth (MHz)	
		Chain 0	Chain 1
38	5190	36.12	36.00
46	5230	36.48	36.48

802.11ac (VHT80)

Channel	Frequency (MHz)	Occupied Bandwidth (MHz)	
		Chain 0	Chain 1
42	5210	75.88	75.88

Spectrum Plot of Worst Value

802.11ac (VHT20)

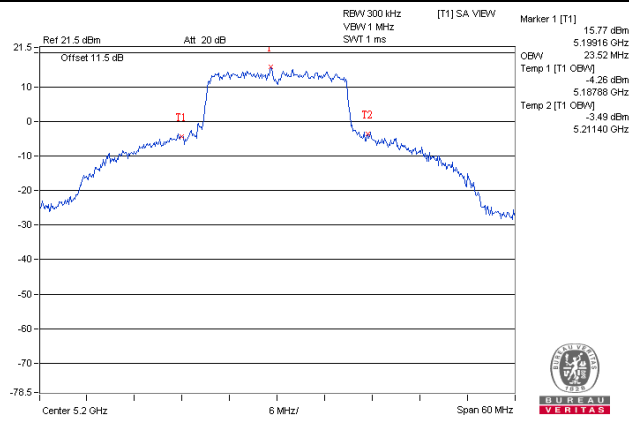

802.11ac (VHT40)

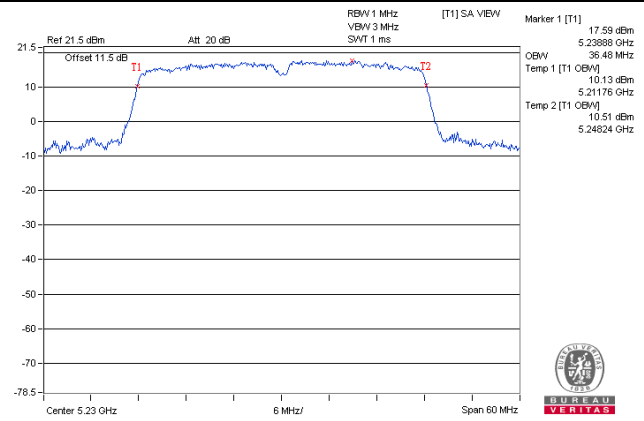

802.11ac (VHT80)

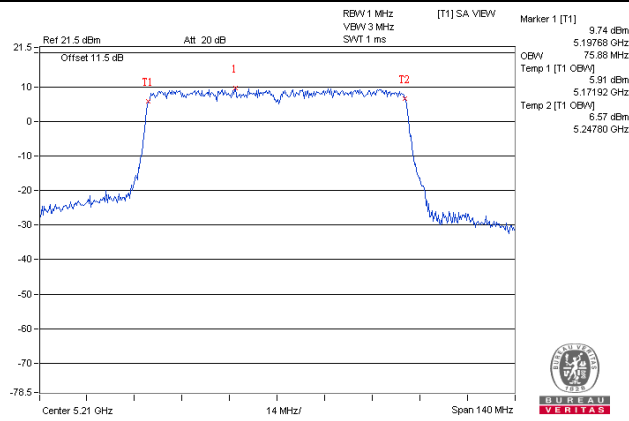

5GHz U-NII-3 Band:

CDD Mode

802.11a

Channel	Frequency (MHz)	Occupied Bandwidth (MHz)			
		Chain 0	Chain 1	Chain 2	Chain 3
149	5745	16.52	16.60	16.52	16.43
157	5785	16.56	16.68	16.44	16.44
165	5825	16.44	16.68	16.44	16.44

802.11ac (VHT20)

Channel	Frequency (MHz)	Occupied Bandwidth (MHz)			
		Chain 0	Chain 1	Chain 2	Chain 3
149	5745	17.64	17.64	17.64	17.64
157	5785	17.64	17.64	17.64	17.64
165	5825	17.64	17.76	17.64	17.64

802.11ac (VHT40)

Channel	Frequency (MHz)	Occupied Bandwidth (MHz)			
		Chain 0	Chain 1	Chain 2	Chain 3
151	5755	36.24	36.00	36.12	36.24
159	5795	36.24	36.00	36.12	36.00

802.11ac (VHT80)

Channel	Frequency (MHz)	Occupied Bandwidth (MHz)			
		Chain 0	Chain 1	Chain 2	Chain 3
155	5775	75.88	75.60	75.88	76.16

Spectrum Plot of Worst Value

802.11a

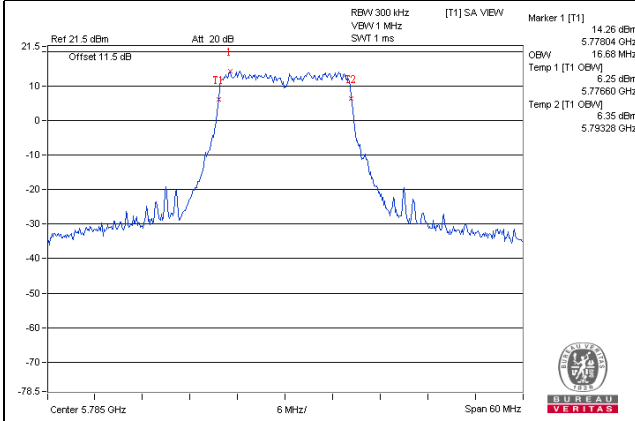

802.11ac (VHT20)

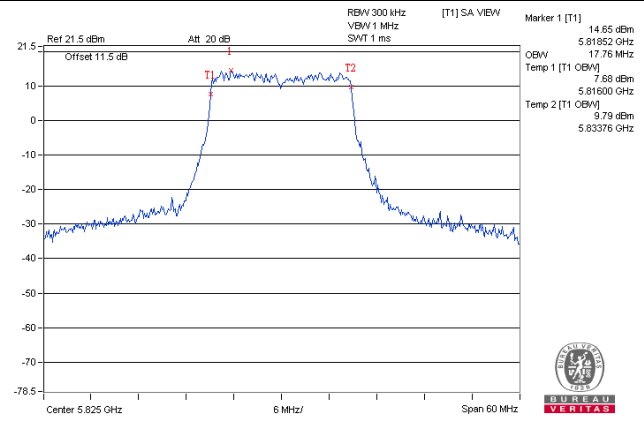

802.11ac (VHT40)

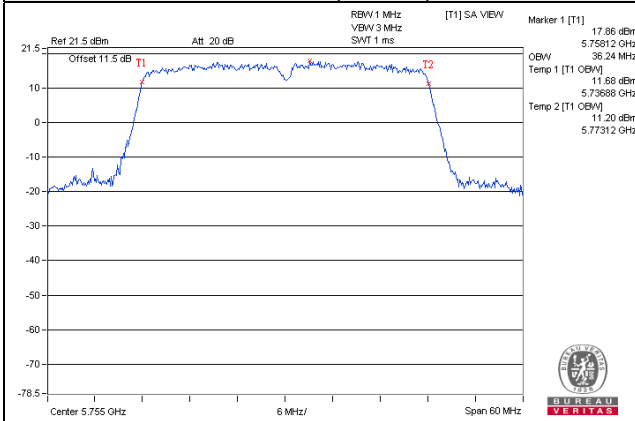

802.11ac (VHT80)

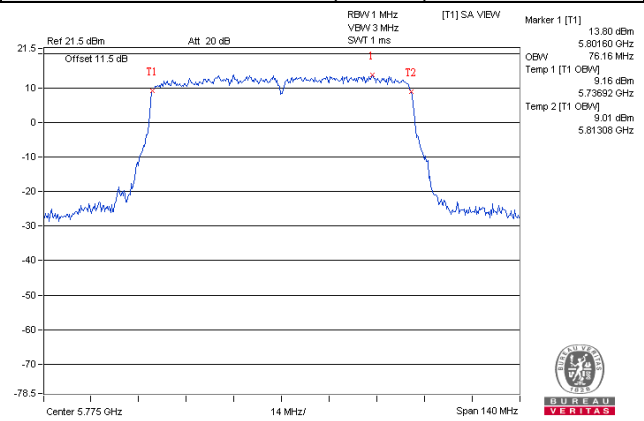

Beamforming_NSS1 Mode

802.11ac (VHT20)

Channel	Frequency (MHz)	Occupied Bandwidth (MHz)			
		Chain 0	Chain 1	Chain 2	Chain 3
149	5745	17.65	17.65	17.65	17.65
157	5785	17.64	17.64	17.64	17.64
165	5825	17.64	17.64	17.64	17.64

802.11ac (VHT40)

Channel	Frequency (MHz)	Occupied Bandwidth (MHz)			
		Chain 0	Chain 1	Chain 2	Chain 3
151	5755	36.12	36.00	36.12	36.00
159	5795	36.12	36.00	36.12	36.00

802.11ac (VHT80)

Channel	Frequency (MHz)	Occupied Bandwidth (MHz)			
		Chain 0	Chain 1	Chain 2	Chain 3
155	5775	75.88	75.60	75.88	75.60

Spectrum Plot of Worst Value

802.11ac (VHT20)

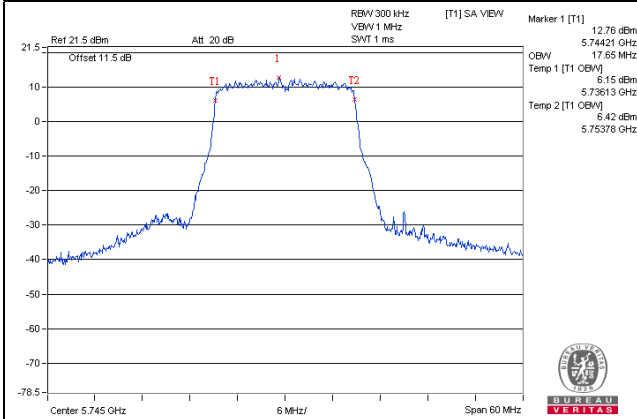

802.11ac (VHT40)

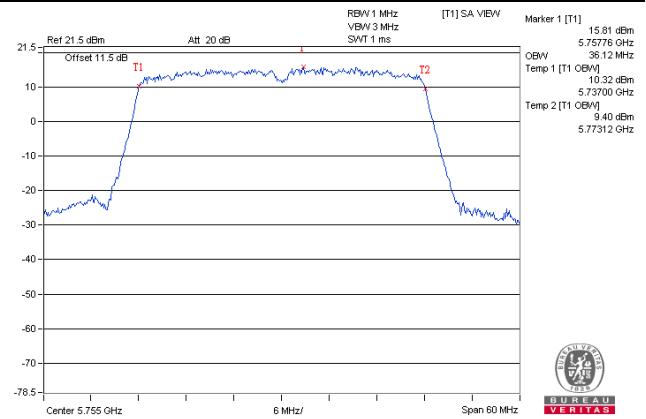

802.11ac (VHT80)

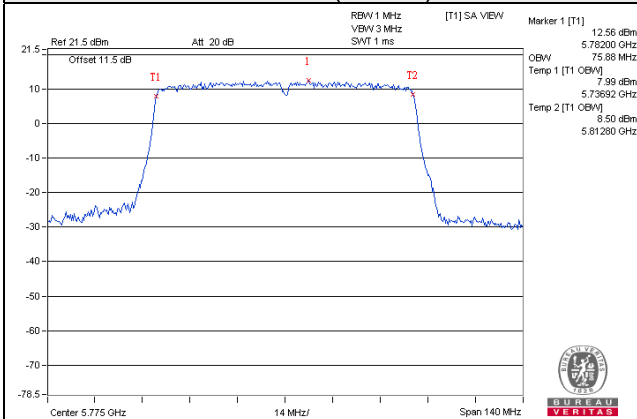

Beamforming_NSS2 Mode

802.11ac (VHT20)

Channel	Frequency (MHz)	Occupied Bandwidth (MHz)			
		Chain 0	Chain 1	Chain 2	Chain 3
149	5745	17.65	17.65	17.65	17.65
157	5785	17.64	17.64	17.64	17.64
165	5825	17.64	17.64	17.64	17.64

802.11ac (VHT40)

Channel	Frequency (MHz)	Occupied Bandwidth (MHz)			
		Chain 0	Chain 1	Chain 2	Chain 3
151	5755	36.24	36.00	36.12	36.12
159	5795	36.12	36.00	36.12	36.12

802.11ac (VHT80)

Channel	Frequency (MHz)	Occupied Bandwidth (MHz)			
		Chain 0	Chain 1	Chain 2	Chain 3
155	5775	75.88	75.88	76.44	76.16

Spectrum Plot of Worst Value

802.11ac (VHT20)

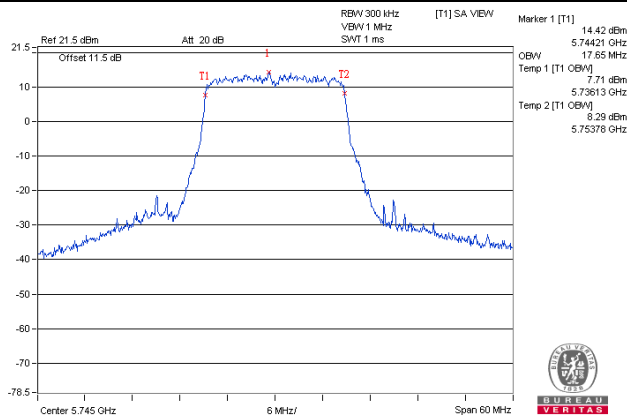

802.11ac (VHT40)

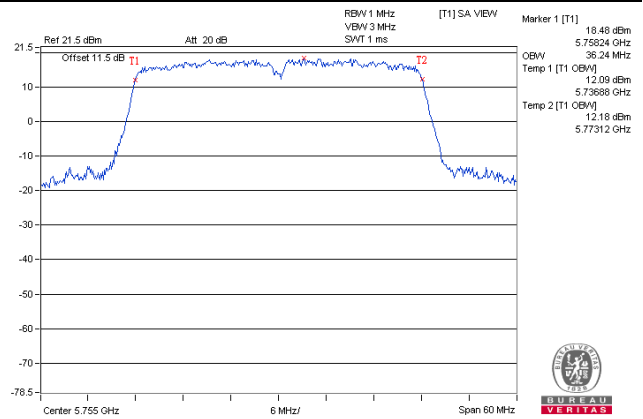

802.11ac (VHT80)

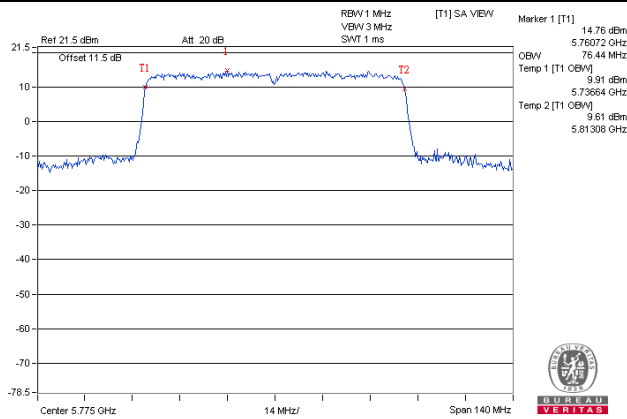

4.4 Peak Power Spectral Density Measurement

4.4.1 Limits of Peak Power Spectral Density Measurement

Operation Band	EUT Category		LIMIT
U-NII-1		Outdoor Access Point	17dBm/ MHz
		Fixed point-to-point Access Point	
	√	Indoor Access Point	
		Mobile and Portable client device	11dBm/ MHz
U-NII-2A	---		11dBm/ MHz
U-NII-2C	---		11dBm/ MHz
U-NII-3	√		30dBm/ 500kHz

4.4.2 Test Setup

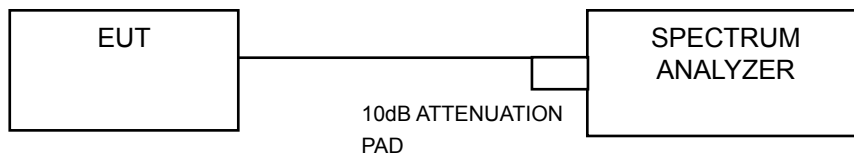

4.4.3 Test Instruments

Refer to section 4.1.2 to get information of above instrument.

4.4.4 Test Procedure

For U-NII-1 band:

Duty cycle of test signal is $\geq 98\%$

Using method SA-1

- 1) Set span to encompass the entire emission bandwidth (EBW) of the signal.
- 2) Set RBW = 30 kHz, Set VBW ≥ 1 MHz, Detector = RMS
- 3) Set Channel power measure = 1MHz
- 4) Sweep time = auto, trigger set to "free run".
- 5) Trace average at least 100 traces in power averaging mode.
- 6) Record the max value

Duty cycle of test signal is $< 98\%$

Using method SA-2

- 1) Set span to encompass the entire emission bandwidth (EBW) of the signal.
- 2) Set RBW = 30 kHz, Set VBW ≥ 1 MHz, Detector = RMS
- 3) Set Channel power measure = 1MHz
- 4) Sweep time = auto, trigger set to "free run".
- 5) Trace average at least 100 traces in power averaging mode.
- 6) Record the max value and add $10 \log (1/\text{duty cycle})$

For U-NII-3 band:

- 1) Set span to encompass the entire emission bandwidth (EBW) of the signal.
- 2) Set RBW = 500 kHz, Set VBW ≥ 3 RBW, Detector = RMS
- 3) Sweep time = auto, trigger set to "free run".
- 4) Trace average at least 100 traces in power averaging mode.
- 5) Record the max value and add $10 \log (1/\text{duty cycle})$
- 6) Scale the observed power level to an equivalent value in 500 kHz by adjusting (reducing) the measured power by a bandwidth correction factor (BWCF) where $\text{BWCF} = 10 \log(500 \text{ kHz}/300 \text{ kHz})$

4.4.5 Deviation from Test Standard

No deviation.

4.4.6 EUT Operating Condition

Same as Item 4.3.6.

4.4.7 Test Results

For U-NII-1 Band

CDD Mode

802.11a

Chan.	Freq. (MHz)	PSD (dBm)		Total PSD w/o duty factor (dBm)	Duty factor	Total PSD with duty factor (dBm)	Max. Limit (dBm)	Pass / Fail
		Chain 0	Chain 1					
36	5180	8.63	8.64	11.65	0.18	11.83	17.00	Pass
40	5200	11.03	11.12	14.09	0.18	14.27	17.00	Pass
48	5240	11.07	11.36	14.23	0.18	14.41	17.00	Pass

Note:

1. Method 1 of power density measurement of KDB 662911 is using for calculating total power density. Total power density is summing entire spectra across corresponding frequency bins on the various outputs by computer.
2. Directional gain = 5.812dBi < 6dBi, so the limit no need to reduced.
3. Refer to section 3.3 for duty cycle spectrum plot.

802.11ac (VHT20)

Chan.	Freq. (MHz)	PSD (dBm)		Total PSD (dBm)	Max. Limit (dBm)	Pass / Fail
		Chain 0	Chain 1			
36	5180	8.21	8.40	11.32	17.00	Pass
40	5200	10.78	10.64	13.72	17.00	Pass
48	5240	10.92	11.20	14.07	17.00	Pass

Note:

1. Method 1 of power density measurement of KDB 662911 is using for calculating total power density. Total power density is summing entire spectra across corresponding frequency bins on the various outputs by computer.
2. Directional gain = 5.812dBi < 6dBi, so the limit no need to reduced.

802.11ac (VHT40)

Chan.	Freq. (MHz)	PSD (dBm)		Total PSD w/o duty factor (dBm)	Duty factor	Total PSD with duty factor (dBm)	Max. Limit (dBm)	Pass / Fail
		Chain 0	Chain 1					
38	5190	3.78	3.83	6.81	0.16	6.97	17.00	Pass
46	5230	7.67	7.98	10.84	0.16	11.00	17.00	Pass

Note:

1. Method 1 of power density measurement of KDB 662911 is using for calculating total power density. Total power density is summing entire spectra across corresponding frequency bins on the various outputs by computer.
2. Directional gain = 5.812dBi < 6dBi, so the limit no need to reduced.
3. Refer to section 3.3 for duty cycle spectrum plot.

802.11ac (VHT80)

Chan.	Freq. (MHz)	PSD (dBm)		Total PSD w/o duty factor (dBm)	Duty factor	Total PSD with duty factor (dBm)	Max. Limit (dBm)	Pass / Fail
		Chain 0	Chain 1					
42	5210	0.20	0.50	3.36	0.38	3.74	17.00	Pass

Note:

1. Method 1 of power density measurement of KDB 662911 is using for calculating total power density. Total power density is summing entire spectra across corresponding frequency bins on the various outputs by computer.
2. Directional gain = 5.812dBi < 6dBi, so the limit no need to reduced.
3. Refer to section 3.3 for duty cycle spectrum plot.

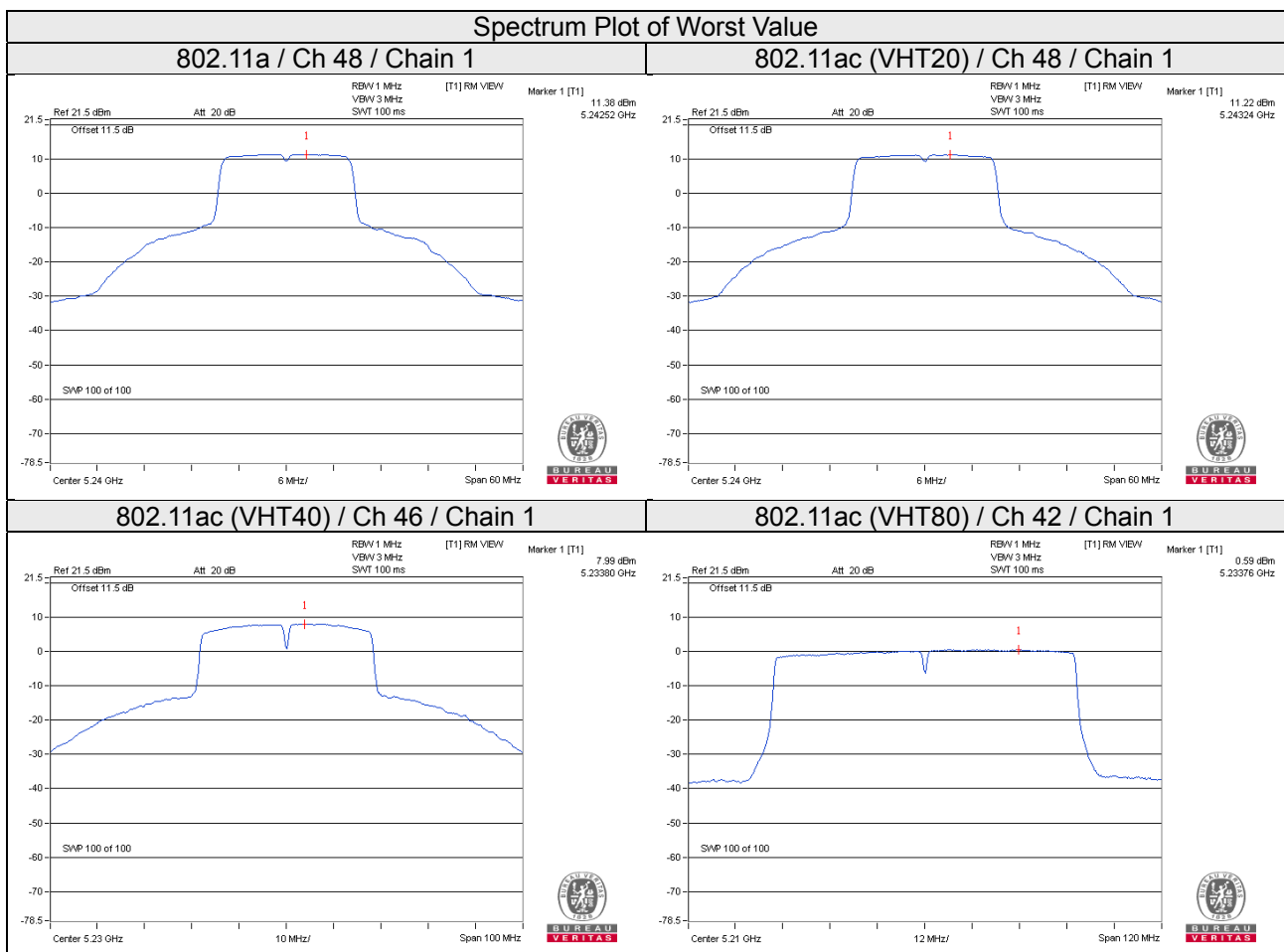

Beamforming_NSS1 Mode

802.11ac (VHT20)

Chan.	Freq. (MHz)	PSD (dBm)		Total PSD (dBm)	Max. Limit (dBm)	Pass / Fail
		Chain 0	Chain 1			
36	5180	7.90	8.42	11.18	17.00	Pass
40	5200	10.69	11.58	14.17	17.00	Pass
48	5240	10.98	10.58	13.79	17.00	Pass

Note:

1. Method 1 of power density measurement of KDB 662911 is using for calculating total power density. Total power density is summing entire spectra across corresponding frequency bins on the various outputs by computer.
2. Directional gain = 5.812dBi < 6dBi, so the limit no need to reduced.

802.11ac (VHT40)

Chan.	Freq. (MHz)	PSD (dBm)		Total PSD w/o duty factor (dBm)	Duty factor	Total PSD with duty factor (dBm)	Max. Limit (dBm)	Pass / Fail
		Chain 0	Chain 1					
38	5190	3.30	3.69	6.51	0.17	6.68	17.00	Pass
46	5230	7.69	7.12	10.42	0.17	10.59	17.00	Pass

Note:

1. Method 1 of power density measurement of KDB 662911 is using for calculating total power density. Total power density is summing entire spectra across corresponding frequency bins on the various outputs by computer.
2. Directional gain = 5.812dBi < 6dBi, so the limit no need to reduced.
3. Refer to section 3.3 for duty cycle spectrum plot.

802.11ac (VHT80)

Chan.	Freq. (MHz)	PSD (dBm)		Total PSD w/o duty factor (dBm)	Duty factor	Total PSD with duty factor (dBm)	Max. Limit (dBm)	Pass / Fail
		Chain 0	Chain 1					
42	5210	-0.61	-0.11	2.66	0.38	3.04	17.00	Pass

Note:

1. Method 1 of power density measurement of KDB 662911 is using for calculating total power density. Total power density is summing entire spectra across corresponding frequency bins on the various outputs by computer.
2. Directional gain = 5.812dBi < 6dBi, so the limit no need to reduced.
3. Refer to section 3.3 for duty cycle spectrum plot.

Spectrum Plot of Worst Value

802.11ac (VHT20) / Ch 40 / Chain 1

802.11ac (VHT40) / Ch 46 / Chain 0

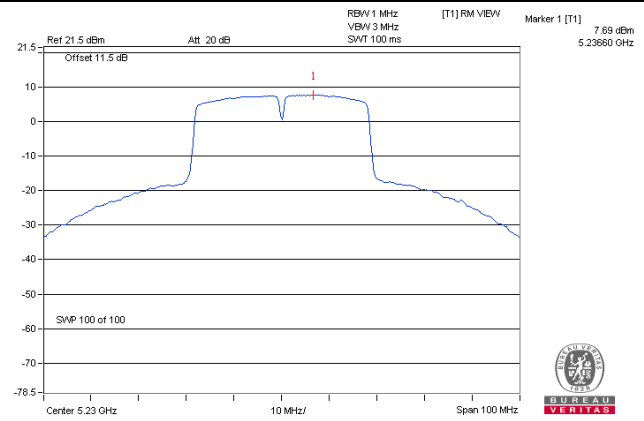
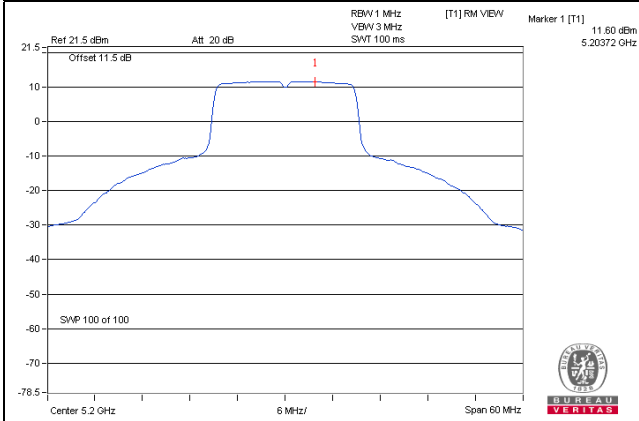

802.11ac (VHT80) / Ch 42 / Chain 1

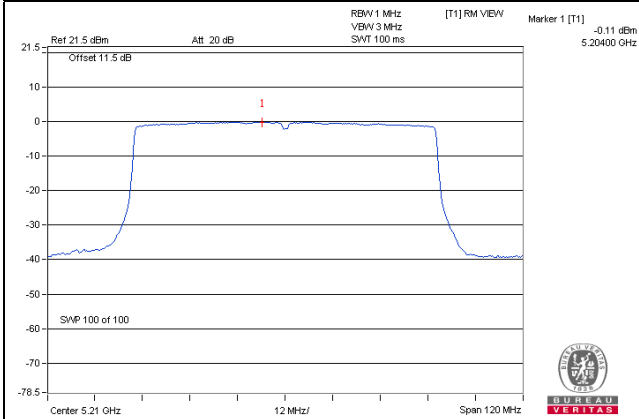

For U-NII-3 Band

CDD Mode

802.11a

TX chain	Channel	Freq. (MHz)	PSD (dBm/300kHz)	PSD (dBm/500kHz)	10 log (N=4) dB	Duty factor	Total PSD (dBm/500kHz)	Limit (dBm/500kHz)	Pass / Fail
0	149	5745	2.13	4.35	6.02	0.19	10.56	27.932	Pass
	157	5785	2.13	4.35	6.02	0.19	10.56	27.932	Pass
	165	5825	2.53	4.75	6.02	0.19	10.96	27.932	Pass
1	149	5745	2.04	4.26	6.02	0.19	10.47	27.932	Pass
	157	5785	1.64	3.86	6.02	0.19	10.07	27.932	Pass
	165	5825	2.21	4.43	6.02	0.19	10.64	27.932	Pass
2	149	5745	2.07	4.29	6.02	0.19	10.50	27.932	Pass
	157	5785	1.67	3.89	6.02	0.19	10.10	27.932	Pass
	165	5825	2.18	4.40	6.02	0.19	10.61	27.932	Pass
3	149	5745	1.83	4.05	6.02	0.19	10.26	27.932	Pass
	157	5785	1.32	3.54	6.02	0.19	9.75	27.932	Pass
	165	5825	1.68	3.90	6.02	0.19	10.11	27.932	Pass

Note:

1. Method 1 of power density measurement of KDB 662911 is using for calculating total power density. Total power density is summing entire spectra across corresponding frequency bins on the various outputs by computer.
2. Directional gain = 8.068dBi > 6dBi, so the limit shall be reduced to $30 - (8.068 - 6) = 27.932\text{dBm}$.
3. Refer to section 3.3 for duty cycle spectrum plot.

802.11ac (VHT20)

TX chain	Channel	Freq. (MHz)	PSD (dBm/300kHz)	PSD (dBm/500kHz)	10 log (N=4) dB	Total PSD (dBm/500kHz)	Limit (dBm/500kHz)	Pass / Fail
0	149	5745	1.58	3.80	6.02	9.82	27.932	Pass
	157	5785	1.53	3.75	6.02	9.77	27.932	Pass
	165	5825	2.01	4.23	6.02	10.25	27.932	Pass
1	149	5745	1.52	3.74	6.02	9.76	27.932	Pass
	157	5785	1.45	3.67	6.02	9.69	27.932	Pass
	165	5825	1.80	4.02	6.02	10.04	27.932	Pass
2	149	5745	1.74	3.96	6.02	9.98	27.932	Pass
	157	5785	1.42	3.64	6.02	9.66	27.932	Pass
	165	5825	1.66	3.88	6.02	9.90	27.932	Pass
3	149	5745	1.49	3.71	6.02	9.73	27.932	Pass
	157	5785	1.07	3.29	6.02	9.31	27.932	Pass
	165	5825	1.50	3.72	6.02	9.74	27.932	Pass

Note:

- Method 1 of power density measurement of KDB 662911 is using for calculating total power density. Total power density is summing entire spectra across corresponding frequency bins on the various outputs by computer.
- Directional gain = 8.068dBi > 6dBi, so the limit shall be reduced to 30-(8.068-6) = 27.932dBm.

802.11ac (VHT40)

TX chain	Channel	Freq. (MHz)	PSD (dBm/300kHz)	PSD (dBm/500kHz)	10 log (N=4) dB	Duty factor	Total PSD (dBm/500kHz)	Limit (dBm/500kHz)	Pass / Fail
0	151	5755	-1.48	0.74	6.02	0.13	6.89	27.932	Pass
	159	5795	-1.17	1.05	6.02	0.13	7.20	27.932	Pass
1	151	5755	-1.26	0.96	6.02	0.13	7.11	27.932	Pass
	159	5795	-0.98	1.24	6.02	0.13	7.39	27.932	Pass
2	151	5755	-1.23	0.99	6.02	0.13	7.14	27.932	Pass
	159	5795	-1.03	1.19	6.02	0.13	7.34	27.932	Pass
3	151	5755	-1.95	0.27	6.02	0.13	6.42	27.932	Pass
	159	5795	-1.57	0.65	6.02	0.13	6.80	27.932	Pass

Note:

- Method 1 of power density measurement of KDB 662911 is using for calculating total power density. Total power density is summing entire spectra across corresponding frequency bins on the various outputs by computer.
- Directional gain = 8.068dBi > 6dBi, so the limit shall be reduced to 30-(8.068-6) = 27.932dBm.
- Refer to section 3.3 for duty cycle spectrum plot.

802.11ac (VHT80)

TX chain	Channel	Freq. (MHz)	PSD (dBm/300kHz)	PSD (dBm/500kHz)	10 log (N=4) dB	Duty factor	Total PSD (dBm/500kHz)	Limit (dBm/500kHz)	Pass / Fail
0	155	5775	-4.97	-2.75	6.02	0.28	3.55	27.932	Pass
1	155	5775	-4.74	-2.52	6.02	0.28	3.78	27.932	Pass
2	155	5775	-4.85	-2.63	6.02	0.28	3.67	27.932	Pass
3	155	5775	-5.73	-3.51	6.02	0.28	2.79	27.932	Pass

Note:

- Method 1 of power density measurement of KDB 662911 is using for calculating total power density. Total power density is summing entire spectra across corresponding frequency bins on the various outputs by computer.
- Directional gain = 8.068dBi > 6dBi, so the limit shall be reduced to $30 - (8.068 - 6) = 27.932$ dBm.
- Refer to section 3.3 for duty cycle spectrum plot.

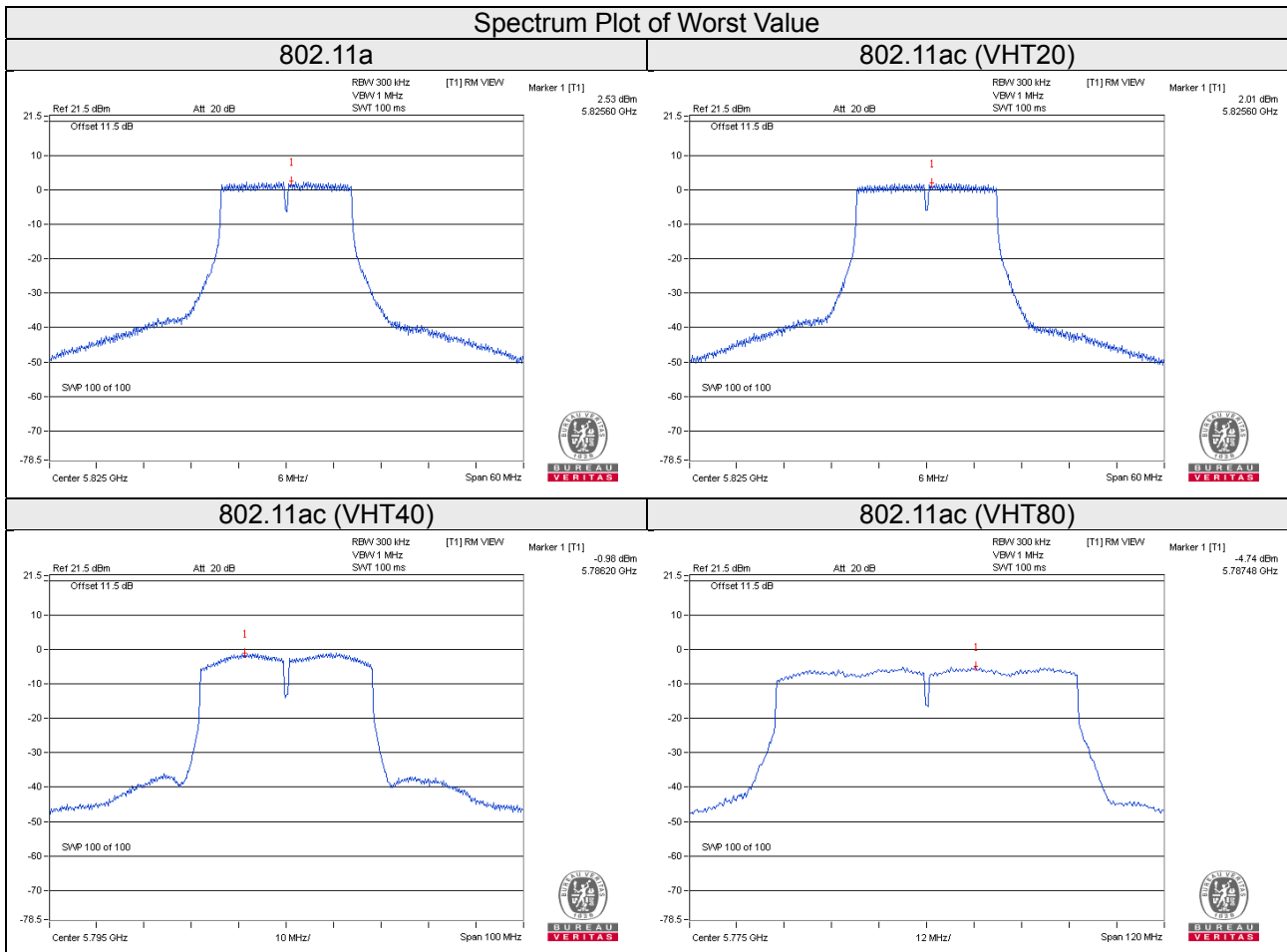

Beamforming_NSS1 Mode

802.11ac (VHT20)

TX chain	Channel	Freq. (MHz)	PSD (dBm/300kHz)	PSD (dBm/500kHz)	10 log (N=4) dB	Total PSD (dBm/500kHz)	Limit (dBm/500kHz)	Pass / Fail
0	149	5745	-0.36	1.86	6.02	7.88	27.932	Pass
	157	5785	-0.29	1.93	6.02	7.95	27.932	Pass
	165	5825	-0.23	1.99	6.02	8.01	27.932	Pass
1	149	5745	-0.57	1.65	6.02	7.67	27.932	Pass
	157	5785	-0.31	1.91	6.02	7.93	27.932	Pass
	165	5825	-0.18	2.04	6.02	8.06	27.932	Pass
2	149	5745	-0.30	1.92	6.02	7.94	27.932	Pass
	157	5785	0.06	2.28	6.02	8.30	27.932	Pass
	165	5825	0.18	2.40	6.02	8.42	27.932	Pass
3	149	5745	-0.47	1.75	6.02	7.77	27.932	Pass
	157	5785	-0.24	1.98	6.02	8.00	27.932	Pass
	165	5825	0.07	2.29	6.02	8.31	27.932	Pass

Note:

- Method 1 of power density measurement of KDB 662911 is using for calculating total power density. Total power density is summing entire spectra across corresponding frequency bins on the various outputs by computer.
- Directional gain = 8.068dBi > 6dBi, so the limit shall be reduced to $30-(8.068-6) = 27.932\text{dBm}$.

802.11ac (VHT40)

TX chain	Channel	Freq. (MHz)	PSD (dBm/300kHz)	PSD (dBm/500kHz)	10 log (N=4) dB	Duty factor	Total PSD (dBm/500kHz)	Limit (dBm/500kHz)	Pass / Fail
0	151	5755	-3.37	-1.15	6.02	0.17	5.04	27.932	Pass
	159	5795	-3.37	-1.15	6.02	0.17	5.04	27.932	Pass
1	151	5755	-3.53	-1.31	6.02	0.17	4.88	27.932	Pass
	159	5795	-3.21	-0.99	6.02	0.17	5.20	27.932	Pass
2	151	5755	-3.49	-1.27	6.02	0.17	4.92	27.932	Pass
	159	5795	-3.33	-1.11	6.02	0.17	5.08	27.932	Pass
3	151	5755	-3.74	-1.52	6.02	0.17	4.67	27.932	Pass
	159	5795	-3.57	-1.35	6.02	0.17	4.84	27.932	Pass

Note:

- Method 1 of power density measurement of KDB 662911 is using for calculating total power density. Total power density is summing entire spectra across corresponding frequency bins on the various outputs by computer.
- Directional gain = 8.068dBi > 6dBi, so the limit shall be reduced to $30-(8.068-6) = 27.932\text{dBm}$.
- Refer to section 3.3 for duty cycle spectrum plot.

802.11ac (VHT80)

TX chain	Channel	Freq. (MHz)	PSD (dBm/300kHz)	PSD (dBm/500kHz)	10 log (N=4) dB	Duty factor	Total PSD (dBm/500kHz)	Limit (dBm/500kHz)	Pass / Fail
0	155	5775	-6.75	-4.53	6.02	0.33	1.82	27.932	Pass
1	155	5775	-6.87	-4.65	6.02	0.33	1.70	27.932	Pass
2	155	5775	-6.98	-4.76	6.02	0.33	1.59	27.932	Pass
3	155	5775	-7.14	-4.92	6.02	0.33	1.43	27.932	Pass

Note:

1. Method 1 of power density measurement of KDB 662911 is using for calculating total power density. Total power density is summing entire spectra across corresponding frequency bins on the various outputs by computer.
2. Directional gain = 8.068dBi > 6dBi, so the limit shall be reduced to $30 - (8.068 - 6) = 27.932$ dBm.
3. Refer to section 3.3 for duty cycle spectrum plot.

Spectrum Plot of Worst Value

802.11ac (VHT20)

802.11ac (VHT40)

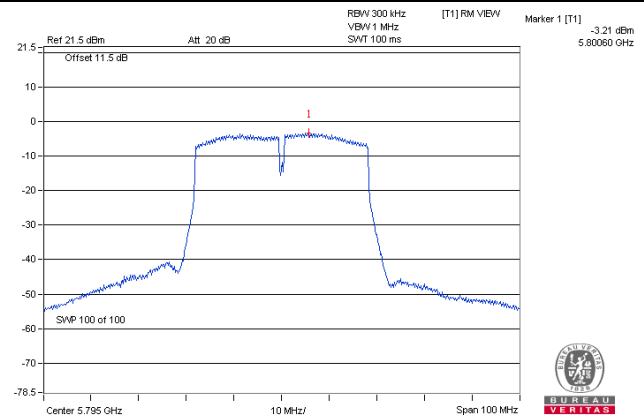
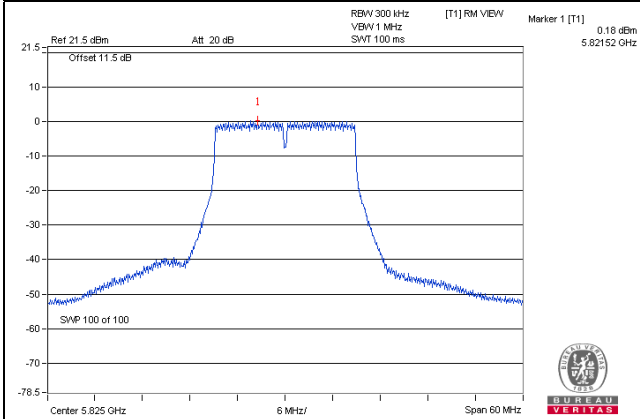

802.11ac (VHT80)

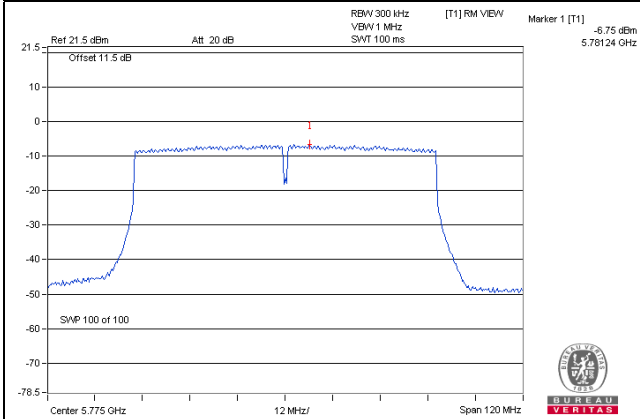

Beamforming_NSS2 Mode

802.11ac (VHT20)

TX chain	Channel	Freq. (MHz)	PSD (dBm/300kHz)	PSD (dBm/500kHz)	10 log (N=4) dB	Total PSD (dBm/500kHz)	Limit (dBm/500kHz)	Pass / Fail
0	149	5745	1.09	3.31	6.02	9.33	30.00	Pass
	157	5785	1.20	3.42	6.02	9.44	30.00	Pass
	165	5825	1.27	3.49	6.02	9.51	30.00	Pass
1	149	5745	1.10	3.32	6.02	9.34	30.00	Pass
	157	5785	1.25	3.47	6.02	9.49	30.00	Pass
	165	5825	1.38	3.60	6.02	9.62	30.00	Pass
2	149	5745	1.06	3.28	6.02	9.30	30.00	Pass
	157	5785	1.33	3.55	6.02	9.57	30.00	Pass
	165	5825	1.54	3.76	6.02	9.78	30.00	Pass
3	149	5745	1.07	3.29	6.02	9.31	30.00	Pass
	157	5785	1.29	3.51	6.02	9.53	30.00	Pass
	165	5825	1.40	3.62	6.02	9.64	30.00	Pass

Note:

- Method 1 of power density measurement of KDB 662911 is using for calculating total power density. Total power density is summing entire spectra across corresponding frequency bins on the various outputs by computer.
- Directional gain = 5.058dBi < 6dBi, so the power density limit is not reduced

802.11ac (VHT40)

TX chain	Channel	Freq. (MHz)	PSD (dBm/300kHz)	PSD (dBm/500kHz)	10 log (N=4) dB	Duty factor	Total PSD (dBm/500kHz)	Limit (dBm/500kHz)	Pass / Fail
0	151	5755	-0.95	1.27	6.02	0.15	7.44	30.00	Pass
	159	5795	-0.86	1.36	6.02	0.15	7.53	30.00	Pass
1	151	5755	-0.91	1.31	6.02	0.15	7.48	30.00	Pass
	159	5795	-0.80	1.42	6.02	0.15	7.59	30.00	Pass
2	151	5755	-1.07	1.15	6.02	0.15	7.32	30.00	Pass
	159	5795	-0.85	1.37	6.02	0.15	7.54	30.00	Pass
3	151	5755	-1.47	0.75	6.02	0.15	6.92	30.00	Pass
	159	5795	-1.14	1.08	6.02	0.15	7.25	30.00	Pass

Note:

- Method 1 of power density measurement of KDB 662911 is using for calculating total power density. Total power density is summing entire spectra across corresponding frequency bins on the various outputs by computer.
- Directional gain = 5.058dBi < 6dBi, so the power density limit is not reduced.
- Refer to section 3.3 for duty cycle spectrum plot.

802.11ac (VHT80)

TX chain	Channel	Freq. (MHz)	PSD (dBm/300kHz)	PSD (dBm/500kHz)	10 log (N=4) dB	Duty factor	Total PSD (dBm/500kHz)	Limit (dBm/500kHz)	Pass / Fail
0	155	5775	-4.24	-2.02	6.02	0.27	4.27	30.00	Pass
1	155	5775	-4.27	-2.05	6.02	0.27	4.24	30.00	Pass
2	155	5775	-4.65	-2.43	6.02	0.27	3.86	30.00	Pass
3	155	5775	-4.80	-2.58	6.02	0.27	3.71	30.00	Pass

Note:

1. Method 1 of power density measurement of KDB 662911 is using for calculating total power density. Total power density is summing entire spectra across corresponding frequency bins on the various outputs by computer.
2. Directional gain = 5.058dBi < 6dBi, so the power density limit is not reduced
3. Refer to section 3.3 for duty cycle spectrum plot.

Spectrum Plot of Worst Value

802.11ac (VHT20)

802.11ac (VHT40)

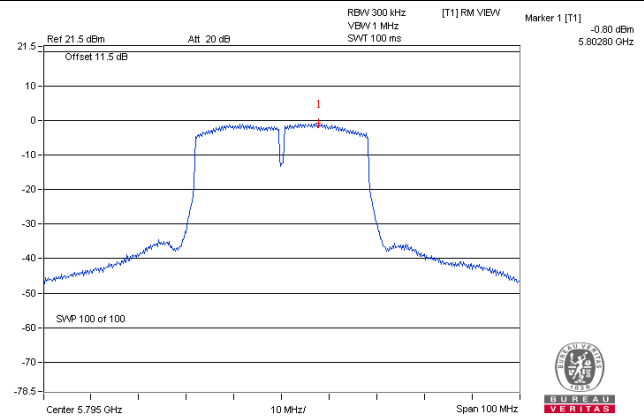
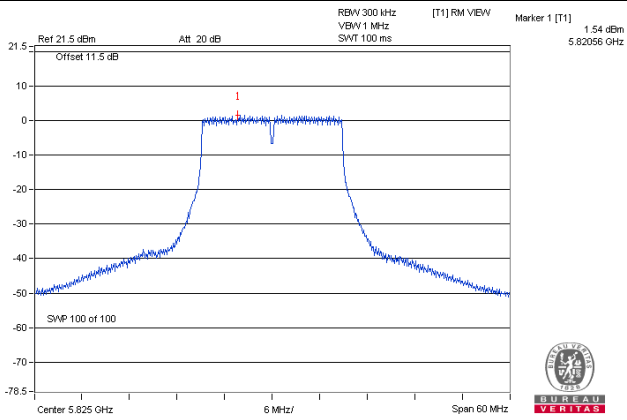

802.11ac (VHT80)

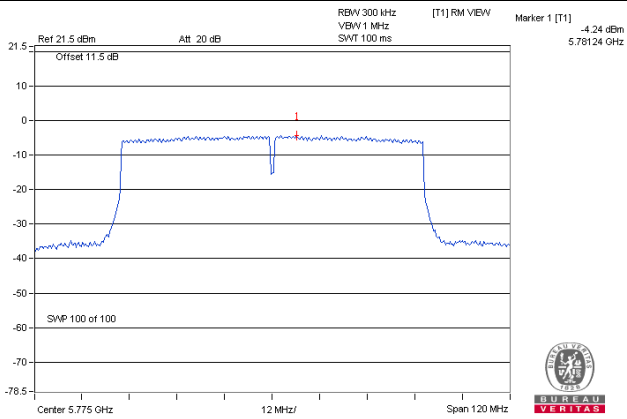

4.5 Frequency Stability

4.5.1 Limits of Frequency Stability Measurement

The frequency of the carrier signal shall be maintained within band of operation

4.5.2 Test Setup

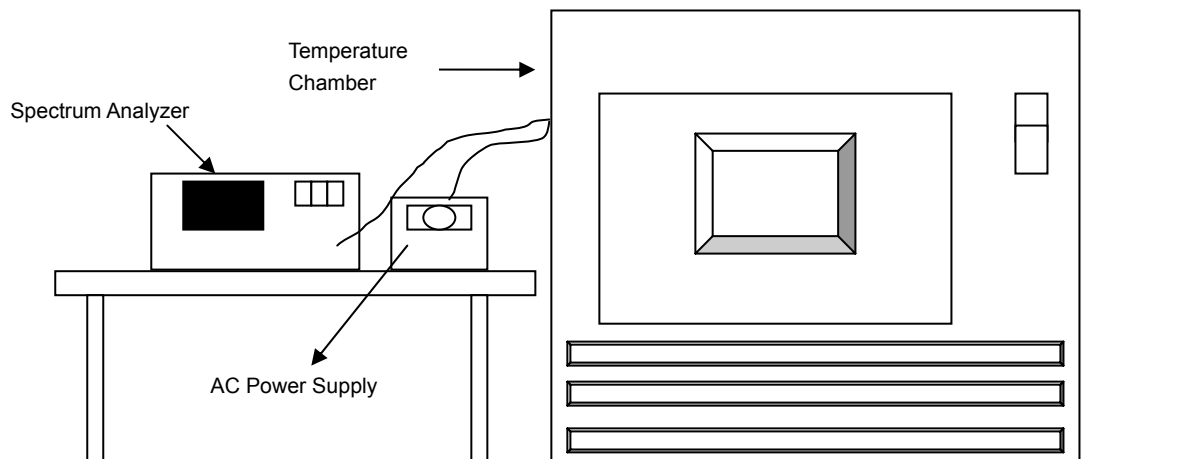

4.5.3 Test Instruments

Refer to section 4.1.2 to get information of above instrument.

4.5.4 Test Procedure

- The EUT was placed inside the environmental test chamber and powered by nominal AC voltage.
- Turn the EUT on and couple its output to a spectrum analyzer.
- Turn the EUT off and set the chamber to the highest temperature specified.
- Allow sufficient time (approximately 30 min) for the temperature of the chamber to stabilize, turn the EUT on and measure the operating frequency after 2, 5, and 10 minutes.
- Repeat step 2 and 3 with the temperature chamber set to the lowest temperature.
- The test chamber was allowed to stabilize at +20 degree C for a minimum of 30 minutes. The supply voltage was then adjusted on the EUT from 85% to 115% and the frequency record.

4.5.5 Deviation from Test Standard

No deviation.

4.5.6 EUT Operating Condition

Set the EUT transmit at un-modulation mode to test frequency stability.

4.5.7 Test Results

Frequency Stability Versus Temp.									
Operating Frequency: 5180MHz									
Temp. (°C)	Power Supply (Vac)	0 Minute		2 Minute		5 Minute		10 Minute	
		Measured Frequency (MHz)	Frequency Drift (%)	Measured Frequency (MHz)	Frequency Drift (%)	Measured Frequency (MHz)	Frequency Drift (%)	Measured Frequency (MHz)	Frequency Drift (%)
50	120	5180.0162	0.00031	5180.0156	0.00030	5180.0154	0.00030	5180.0177	0.00034
40	120	5180.0145	0.00028	5180.0146	0.00028	5180.0145	0.00028	5180.0117	0.00023
30	120	5179.9803	-0.00038	5179.9833	-0.00032	5179.9839	-0.00031	5179.9834	-0.00032
20	120	5179.9775	-0.00043	5179.9803	-0.00038	5179.9774	-0.00044	5179.9795	-0.00040
10	120	5180.0063	0.00012	5180.0083	0.00016	5180.0058	0.00011	5180.0089	0.00017
0	120	5179.9776	-0.00043	5179.9766	-0.00045	5179.9787	-0.00041	5179.9774	-0.00044
-10	120	5179.9804	-0.00038	5179.9802	-0.00038	5179.9777	-0.00043	5179.9773	-0.00044
-20	120	5180.0219	0.00042	5180.0195	0.00038	5180.0168	0.00032	5180.0181	0.00035
-30	120	5180.0074	0.00014	5180.0047	0.00009	5180.0077	0.00015	5180.0048	0.00009

Frequency Stability Versus Voltage									
Operating Frequency: 5180MHz									
Temp. (°C)	Power Supply (Vac)	0 Minute		2 Minute		5 Minute		10 Minute	
		Measured Frequency (MHz)	Frequency Drift (%)	Measured Frequency (MHz)	Frequency Drift (%)	Measured Frequency (MHz)	Frequency Drift (%)	Measured Frequency (MHz)	Frequency Drift (%)
20	138	5179.9778	-0.00043	5179.9803	-0.00038	5179.9776	-0.00043	5179.9787	-0.00041
	120	5179.9775	-0.00043	5179.9803	-0.00038	5179.9774	-0.00044	5179.9795	-0.00040
	102	5179.9782	-0.00042	5179.9813	-0.00036	5179.9772	-0.00044	5179.9800	-0.00039

4.6 6dB Bandwidth Measurement

4.6.1 Limits of 6dB Bandwidth Measurement

The minimum of 6dB Bandwidth Measurement is 0.5MHz.

4.6.2 Test Setup

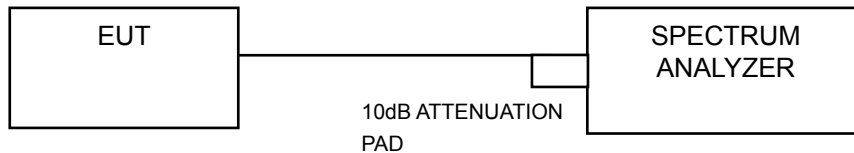

4.6.3 Test Instruments

Refer to section 4.1.2 to get information of above instrument.

4.6.4 Test Procedure

- Set resolution bandwidth (RBW) = 100kHz
- Set the video bandwidth (VBW) $\geq 3 \times$ RBW, Detector = Peak
- Trace mode = max hold
- Sweep = auto couple
- Measure the maximum width of the emission that is constrained by the frequencies associated with the two amplitude points (upper and lower) that are attenuated by 6 dB relative to the maximum level measured in the fundamental emission

4.6.5 Deviation from Test Standard

No deviation.

4.6.6 EUT Operating Condition

The software provided by client to enable the EUT under transmission Condition continuously at lowest, middle and highest channel frequencies individually.

4.6.7 Test Results

CDD Mode

802.11a

Channel	Frequency (MHz)	6dB Bandwidth (MHz)				Minimum Limit (MHz)	Pass / Fail
		Chain 0	Chain 1	Chain 2	Chain 3		
149	5745	16.36	16.39	16.38	16.36	0.5	Pass
157	5785	16.38	16.40	16.38	16.37	0.5	Pass
165	5825	16.37	16.40	16.39	16.38	0.5	Pass

802.11ac (VHT20)

Channel	Frequency (MHz)	6dB Bandwidth (MHz)				Minimum Limit (MHz)	Pass / Fail
		Chain 0	Chain 1	Chain 2	Chain 3		
149	5745	17.56	17.63	17.63	17.21	0.5	Pass
157	5785	17.56	17.63	17.61	17.18	0.5	Pass
165	5825	17.59	17.63	17.57	17.61	0.5	Pass

802.11ac (VHT40)

Channel	Frequency (MHz)	6dB Bandwidth (MHz)				Minimum Limit (MHz)	Pass / Fail
		Chain 0	Chain 1	Chain 2	Chain 3		
151	5755	35.20	35.21	35.18	35.21	0.5	Pass
159	5795	35.20	35.16	35.21	35.93	0.5	Pass

802.11ac (VHT80)

Channel	Frequency (MHz)	6dB Bandwidth (MHz)				Minimum Limit (MHz)	Pass / Fail
		Chain 0	Chain 1	Chain 2	Chain 3		
155	5775	75.52	74.20	75.44	75.47	0.5	Pass

Spectrum Plot of Worst Value

802.11a

802.11ac (VHT20)

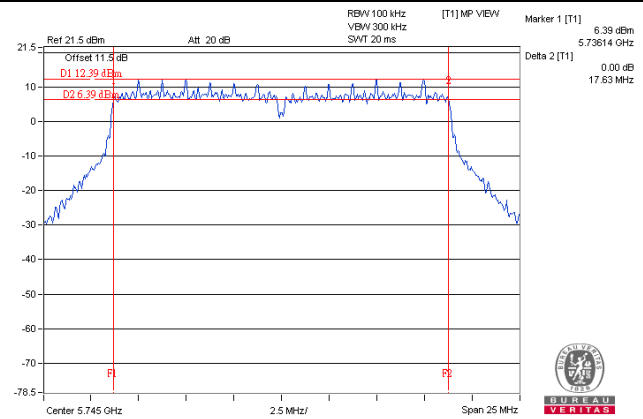
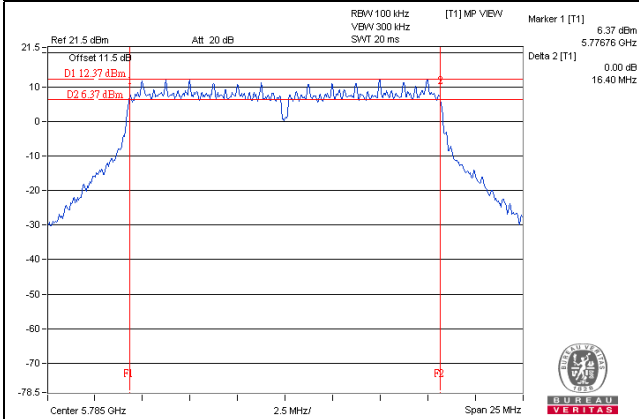

802.11ac (VHT40)

802.11ac (VHT80)

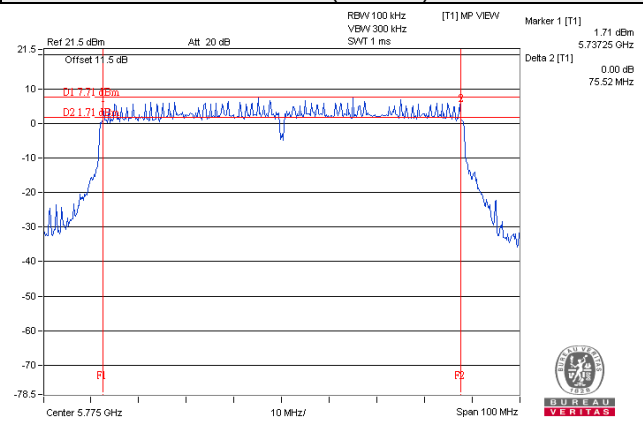
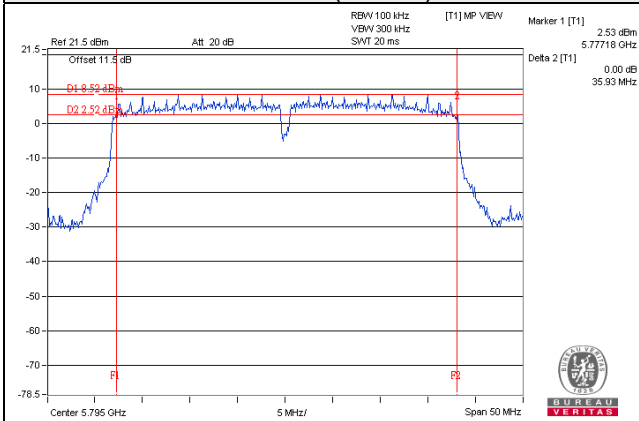

Beamforming_NSS1 Mode

802.11ac (VHT20)

Channel	Frequency (MHz)	6dB Bandwidth (MHz)				Minimum Limit (MHz)	Pass / Fail
		Chain 0	Chain 1	Chain 2	Chain 3		
149	5745	17.56	17.60	17.59	17.56	0.5	Pass
157	5785	17.57	17.58	17.60	17.62	0.5	Pass
165	5825	17.34	16.86	17.59	17.62	0.5	Pass

802.11ac (VHT40)

Channel	Frequency (MHz)	6dB Bandwidth (MHz)				Minimum Limit (MHz)	Pass / Fail
		Chain 0	Chain 1	Chain 2	Chain 3		
151	5755	35.21	35.20	35.20	35.21	0.5	Pass
159	5795	35.46	35.19	35.23	35.23	0.5	Pass

802.11ac (VHT80)

Channel	Frequency (MHz)	6dB Bandwidth (MHz)				Minimum Limit (MHz)	Pass / Fail
		Chain 0	Chain 1	Chain 2	Chain 3		
155	5775	76.40	75.97	76.44	76.02	0.5	Pass

Spectrum Plot of Worst Value

802.11ac (VHT20)

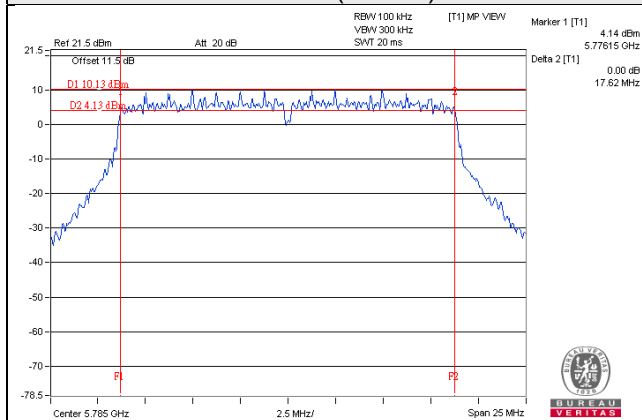

802.11ac (VHT40)

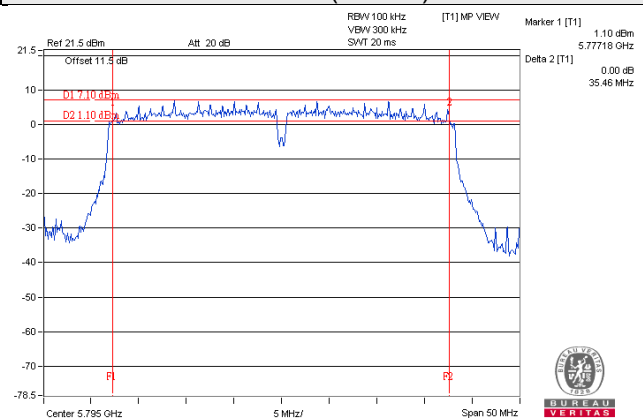

802.11ac (VHT80)

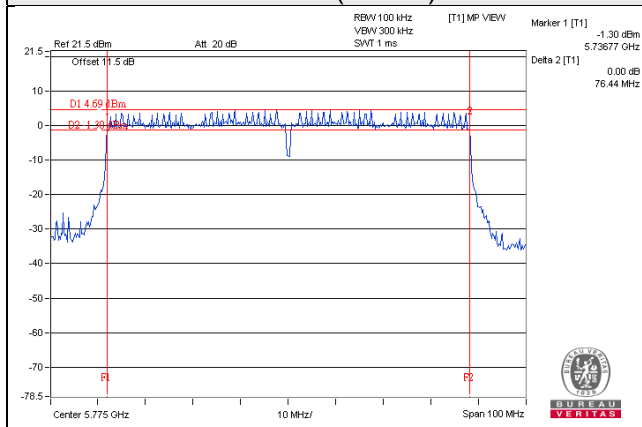

Beamforming_NSS2 Mode

802.11ac (VHT20)

Channel	Frequency (MHz)	6dB Bandwidth (MHz)				Minimum Limit (MHz)	Pass / Fail
		Chain 0	Chain 1	Chain 2	Chain 3		
149	5745	17.21	17.59	17.60	17.56	0.5	Pass
157	5785	17.35	17.60	17.62	17.21	0.5	Pass
165	5825	17.36	17.22	17.61	17.21	0.5	Pass

802.11ac (VHT40)

Channel	Frequency (MHz)	6dB Bandwidth (MHz)				Minimum Limit (MHz)	Pass / Fail
		Chain 0	Chain 1	Chain 2	Chain 3		
151	5755	35.20	35.18	35.20	35.20	0.5	Pass
159	5795	35.22	35.15	35.20	35.20	0.5	Pass

802.11ac (VHT80)

Channel	Frequency (MHz)	6dB Bandwidth (MHz)				Minimum Limit (MHz)	Pass / Fail
		Chain 0	Chain 1	Chain 2	Chain 3		
155	5775	75.76	76.00	75.64	75.99	0.5	Pass

Spectrum Plot of Worst Value

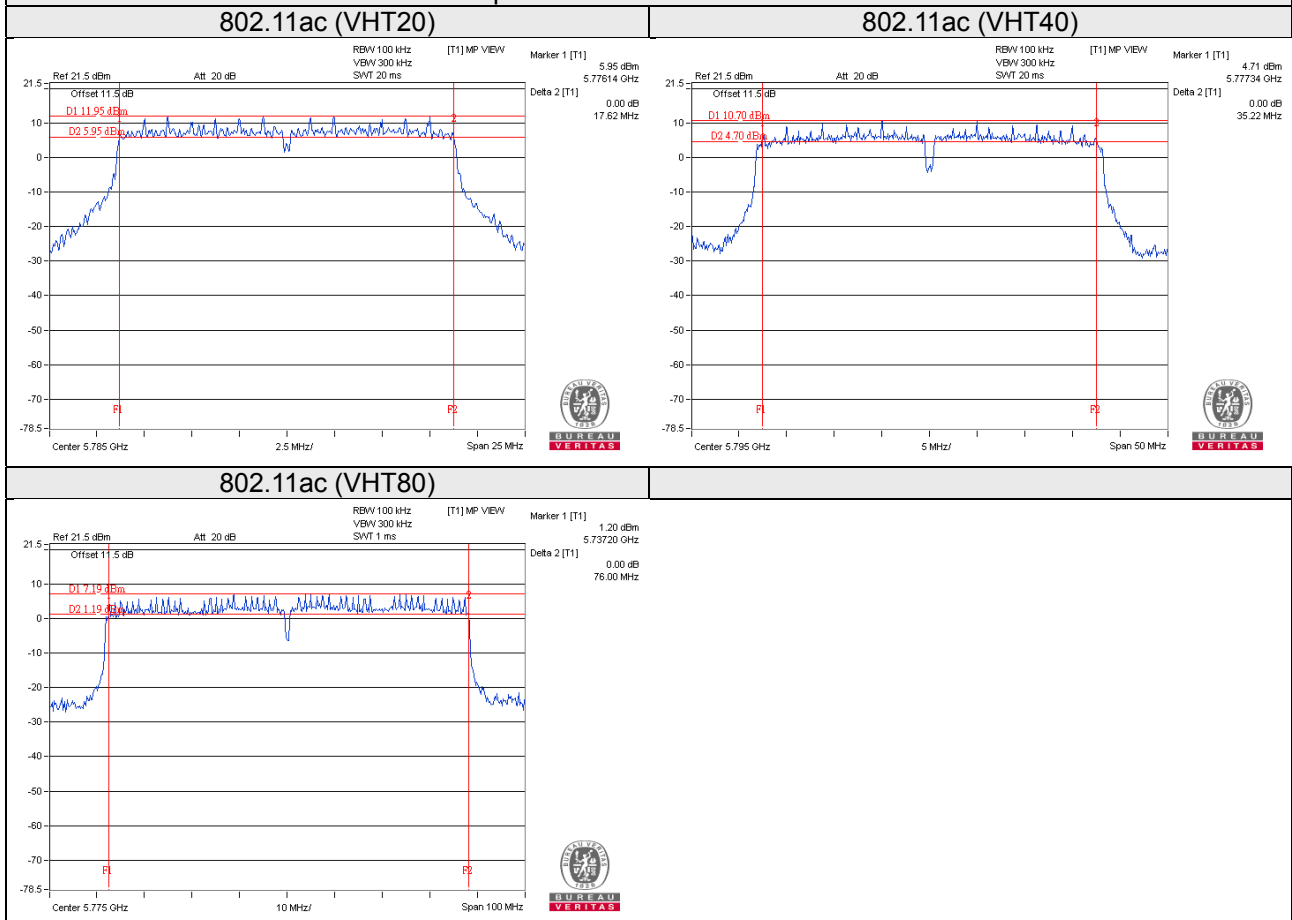

5 Pictures of Test Arrangements

Please refer to the attached file (Test Setup Photo).

Annex A - Radiated Out of Band Emission (OOBE) Measurement (For U-NII-3 band)

802.11a

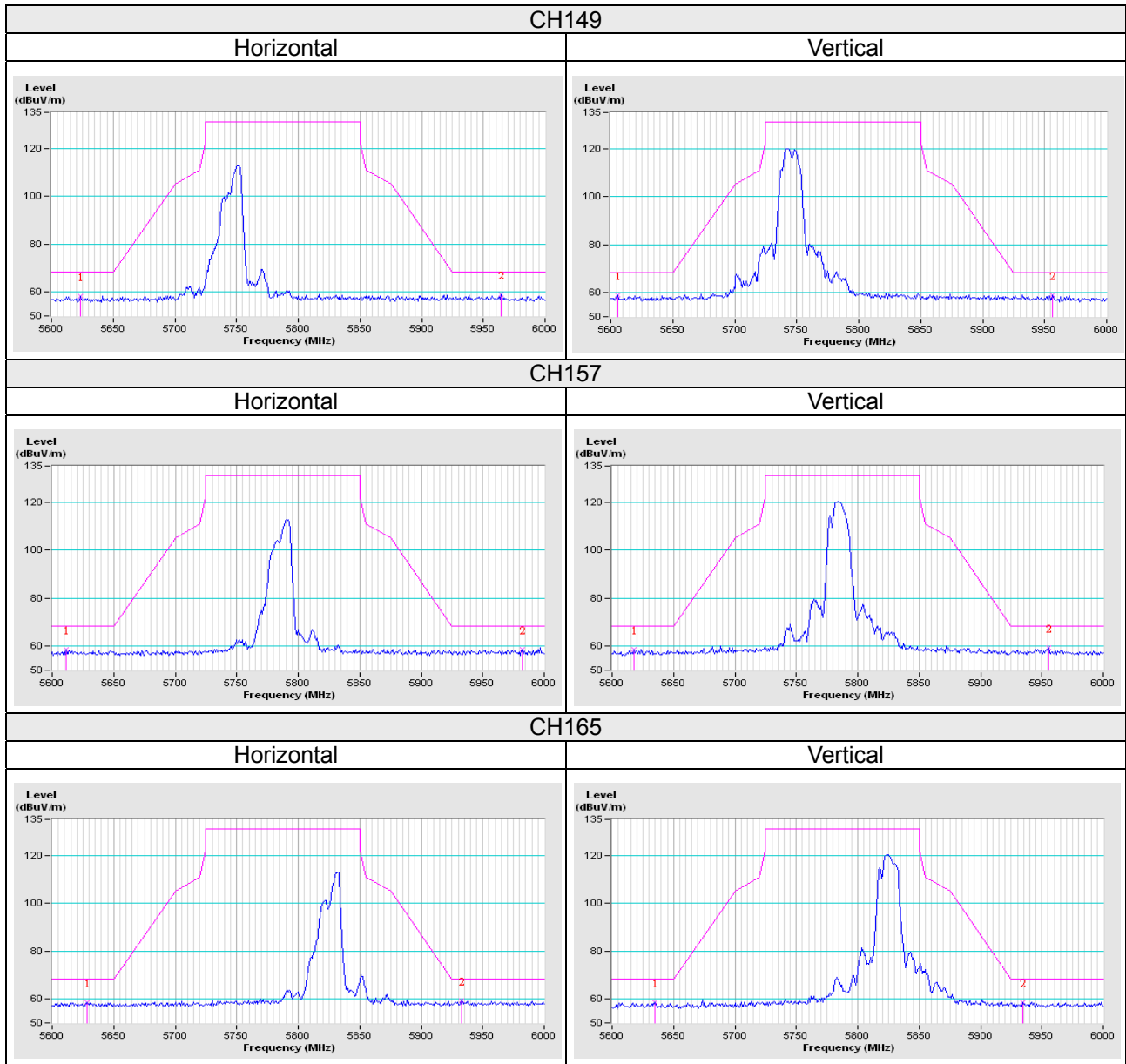

802.11ac (VHT20)

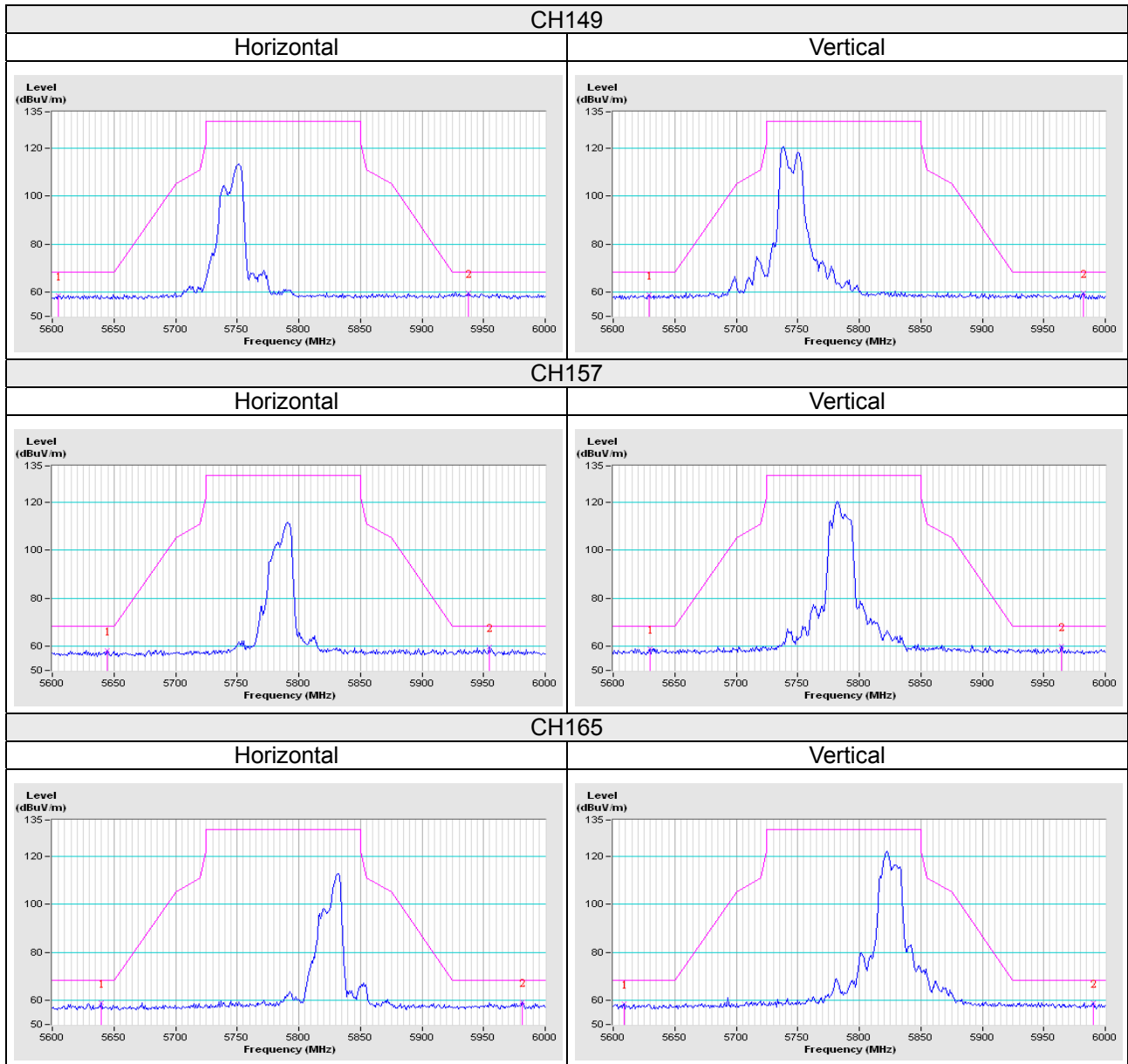

802.11ac (VHT40)

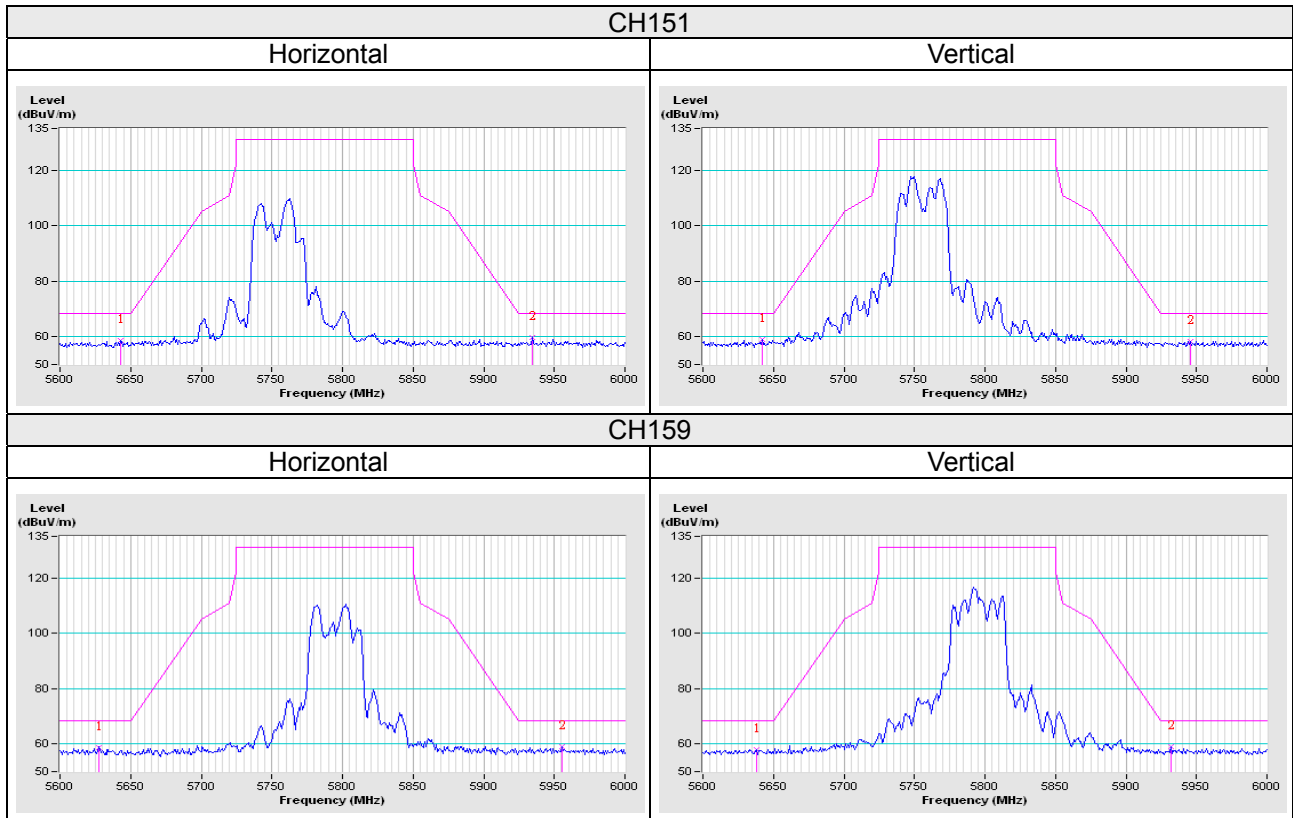

802.11ac (VHT80)

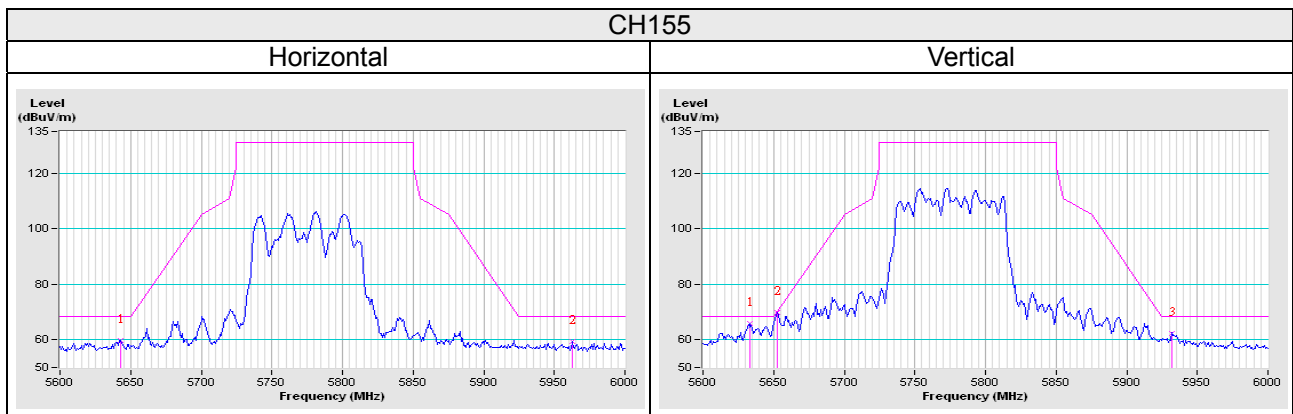

Appendix – Information on the Testing Laboratories

We, Bureau Veritas Consumer Products Services (H.K.) Ltd., Taoyuan Branch, were founded in 1988 to provide our best service in EMC, Radio, Telecom and Safety consultation. Our laboratories are accredited and approved according to ISO/IEC 17025.

If you have any comments, please feel free to contact us at the following:

Linko EMC/RF Lab

Tel: 886-2-26052180

Fax: 886-2-26051924

Hsin Chu EMC/RF/Telecom Lab

Tel: 886-3-6668565

Fax: 886-3-6668323

Hwa Ya EMC/RF/Safety Lab

Tel: 886-3-3183232

Fax: 886-3-3270892

Email: service.adt@tw.bureauveritas.com

Web Site: www.bureauveritas-adt.com

The address and road map of all our labs can be found in our web site also.

--- END ---