

FCC Test Report

Report No.: RF160714C04-1

FCC ID: PY316200340

Test Model: C7800

Received Date: July 14, 2016

Test Date: Nov. 15 to 22, 2016

Issued Date: Dec. 13, 2016

Applicant: NETGEAR INC.

Address: 350 East Plumeria Drive, San Jose CA 96134, USA

Issued By: Bureau Veritas Consumer Products Services (H.K.) Ltd., Taoyuan Branch
Hsin Chu Laboratory

Lab Address: E-2, No.1, Li Hsin 1st Road, Hsinchu Science Park, Hsinchu City 300,
Taiwan R.O.C.

Test Location (1): E-2, No.1, Li Hsin 1st Road, Hsinchu Science Park, Hsinchu City 300,
Taiwan R.O.C.

Test Location (2): No. 49, Ln. 206, Wende Rd., Shangshan Tsuen, Chiung Lin Hsiang, Hsin
Chu Hsien 307, Taiwan R.O.C.



This report is for your exclusive use. Any copying or replication of this report to or for any other person or entity, or use of our name or trademark, is permitted only with our prior written permission. This report sets forth our findings solely with respect to the test samples identified herein. The results set forth in this report are not indicative or representative of the quality or characteristics of the lot from which a test sample was taken or any similar or identical product unless specifically and expressly noted. Our report includes all of the tests requested by you and the results thereof based upon the information that you provided to us. You have 60 days from date of issuance of this report to notify us of any material error or omission caused by our negligence, provided, however, that such notice shall be in writing and shall specifically address the issue you wish to raise. A failure to raise such issue within the prescribed time shall constitute your unqualified acceptance of the completeness of this report, the tests conducted and the correctness of the report contents. Unless specific mention, the uncertainty of measurement has been explicitly taken into account to declare the compliance or non-compliance to the specification. The report must not be used by the client to claim product certification, approval, or endorsement by TAF or any government agencies.

Table of Contents

Release Control Record	4
1 Certificate of Conformity	5
2 Summary of Test Results	6
2.1 Measurement Uncertainty	6
2.2 Modification Record	6
3 General Information	7
3.1 General Description of EUT	7
3.2 Description of Test Modes	11
3.2.1 Test Mode Applicability and Tested Channel Detail	12
3.3 Duty Cycle of Test Signal	15
3.4 Description of Support Units	16
3.4.1 Configuration of System under Test	17
3.5 General Description of Applied Standard	18
4 Test Types and Results	19
4.1 Radiated Emission and Bandedge Measurement	19
4.1.1 Limits of Radiated Emission and Bandedge Measurement	19
4.1.2 Test Instruments	20
4.1.3 Test Procedure	22
4.1.4 Deviation from Test Standard	22
4.1.5 Test Setup	23
4.1.6 EUT Operating Condition	24
4.1.7 Test Results	25
4.2 Conducted Emission Measurement	44
4.2.1 Limits of Conducted Emission Measurement	44
4.2.2 Test Instruments	44
4.2.3 Test Procedure	45
4.2.4 Deviation from Test Standard	45
4.2.5 Test Setup	45
4.2.6 EUT Operating Condition	45
4.2.7 Test Results (Mode 1)	46
4.2.8 Test Results (Mode 2)	48
4.3 Transmit Power Measurement	50
4.3.1 Limits of Transmit Power Measurement	50
4.3.2 Test Setup	50
4.3.3 Test Instruments	50
4.3.4 Test Procedure	50
4.3.5 Deviation from Test Standard	50
4.3.6 EUT Operating Condition	51
4.3.7 Test Result	52
4.4 Occupied Bandwidth Measurement	55
4.4.1 Test Setup	55
4.4.2 Test Instruments	55
4.4.3 Test Procedure	55
4.4.4 Test Results	56
4.5 Peak Power Spectral Density Measurement	62
4.5.1 Limits of Peak Power Spectral Density Measurement	62
4.5.2 Test Setup	62
4.5.3 Test Instruments	62
4.5.4 Test Procedure	63
4.5.5 Deviation from Test Standard	63
4.5.6 EUT Operating Condition	63
4.5.7 Test Results	64
4.6 Frequency Stability Measurement	70

4.6.1	Limits of Frequency Stability Measurement	70
4.6.2	Test Setup.....	70
4.6.3	Test Instruments	70
4.6.4	Test Procedure	70
4.6.5	Deviation from Test Standard	70
4.6.6	EUT Operating Condition	70
4.6.7	Test Results	71
4.7	6dB Bandwidth Measurement	72
4.7.1	Limits of 6dB Bandwidth Measurement.....	72
4.7.2	Test Setup.....	72
4.7.3	Test Instruments	72
4.7.4	Test Procedure	72
4.7.5	Deviation from Test Standard	72
4.7.6	EUT Operating Condition	72
4.7.7	Test Results	73
5	Pictures of Test Arrangements.....	75
	Annex A- Radiated Out of Band Emission (OOBE) Measurement (For U-NII-3 band)	76
	Appendix – Information on the Testing Laboratories	79

Release Control Record

Issue No.	Description	Date Issued
RF160714C04-1	Original release.	Dec. 13, 2016

1 Certificate of Conformity

Product: AC3200 WiFi Cable Modem Router

Brand: NETGEAR

Test Model: C7800

Sample Status: ENGINEERING SAMPLE

Applicant: NETGEAR INC.

Test Date: Nov. 15 to 22, 2016

Standard: 47 CFR FCC Part 15, Subpart E (Section 15.407)
ANSI C63.10: 2013

The above equipment has been tested by **Bureau Veritas Consumer Products Services (H.K.) Ltd., Taoyuan Branch**, and found compliance with the requirement of the above standards. The test record, data evaluation & Equipment Under Test (EUT) configurations represented herein are true and accurate accounts of the measurements of the sample's EMC characteristics under the conditions specified in this report.

Prepared by : Midoli Peng , **Date:** Dec. 13, 2016
Midoli Peng / Specialist

Approved by : May Chen , **Date:** Dec. 13, 2016
May Chen / Manager

2 Summary of Test Results

47 CFR FCC Part 15, Subpart E (Section 15.407)			
FCC Clause	Test Item	Result	Remarks
15.407(b)(6)	AC Power Conducted Emissions	Pass	Meet the requirement of limit. Minimum passing margin is -17.85dB at 11.67188MHz.
15.407(b)(1/2/3/4(i/ii)/6)	Radiated Emissions & Band Edge Measurement*	Pass	Meet the requirement of limit. Minimum passing margin is -0.1dB at 11650.00MHz & 5150.00MHz.
15.407(a)(1/2/3)	Max Average Transmit Power	Pass	Meet the requirement of limit.
---	Occupied Bandwidth Measurement	-	Reference only.
15.407(a)(1/2/3)	Peak Power Spectral Density	Pass	Meet the requirement of limit.
15.407(e)	6dB bandwidth	Pass	Meet the requirement of limit. (U-NII-3 Band only)
15.407(g)	Frequency Stability	Pass	Meet the requirement of limit.
15.203	Antenna Requirement	PASS	Antenna connector is i-pex(MHF) not a standard connector.

*For U-NII-3 band compliance with rule part 15.407(b)(4)(i), the OOB test plots were recorded in Annex A.

2.1 Measurement Uncertainty

Where relevant, the following measurement uncertainty levels have been estimated for tests performed on the EUT as specified in CISPR 16-4-2:

Measurement	Frequency	Expanded Uncertainty (k=2) (±)
Conducted Emissions at mains ports	150kHz ~ 30MHz	1.83 dB
Radiated Emissions up to 1 GHz	30MHz ~ 1GHz	5.34 dB
Radiated Emissions above 1 GHz	1GHz ~ 6GHz	3.41 dB
	6GHz ~ 18GHz	3.49 dB
	18GHz ~ 40GHz	3.30 dB

2.2 Modification Record

There were no modifications required for compliance.

3 General Information

3.1 General Description of EUT

Product	AC3200 WiFi Cable Modem Router
Brand	NETGEAR
Test Model	C7800
Status of EUT	ENGINEERING SAMPLE
Power Supply Rating	DC 19V from power adapter
Modulation Type	CCK, DQPSK, DBPSK for DSSS 64QAM, 16QAM, QPSK, BPSK for OFDM 256QAM for OFDM in 11ac mode and VHT20/40 mode in 2.4GHz band
Modulation Technology	DSSS, OFDM
Transfer Rate	802.11b: up to 11Mbps 802.11a / g: up to 54Mbps 802.11n: up to 600Mbps 802.11ac: up to 1733.3Mbps
Operating Frequency	2.4GHz: 2.412 ~ 2.462GHz 5GHz: 5.18 ~ 5.24GHz, 5.745 ~ 5.825GHz
Number of Channel	2.4GHz: 802.11b, 802.11g, 802.11n (HT20), VHT20: 11 802.11n (HT40), VHT40: 7 5GHz: 802.11a, 802.11n (HT20), 802.11ac (VHT20): 9 802.11n (HT40), 802.11ac (VHT40): 4 802.11ac (VHT80): 2
Output Power	2.4GHz: CDD Mode: 997.948mW Beamforming Mode(NSS1): 562.494 mW Beamforming Mode(NSS2): 997.948mW 5GHz: 5.18GHz ~ 5.24GHz: CDD Mode: 955.585mW Beamforming Mode(NSS1): 597.263mW Beamforming Mode(NSS2): 597.263mW 5.745GHz ~ 5.825GHz: CDD Mode: 981.188mW Beamforming Mode(NSS1): 754.849mW Beamforming Mode(NSS2): 981.188mW
Antenna Type	Refer to Note
Antenna Connector	Refer to Note
Accessory Device	Adapter x1
Data Cable Supplied	RJ45 Cable(unshielded, 1.45m)

Note:

1. Simultaneously transmission condition.

Condition	Technology	
1	WLAN (2.4GHz)	WLAN (5GHz)

Note: The emission of the simultaneous operation has been evaluated and no non-compliance was found.

2. The EUT must be supplied with a power adapter and following different models could be chosen as following table:

No	Brand Name	Model No.	PN	Spec.
1	NETGEAR	AD2003F10	332-10631-01	Input: 100-120V~50/60Hz 1.5A Output: 19V / 3.16A Power cord (Unshielded, 1.8m)
2	NETGEAR	2ABS060K 1 NA	332-10788-01	Input: 100-120V~50/60Hz 1.7A Output: 19V / 3.16A Power cord (Unshielded, 1.8m)

Note: From the above adapters, the radiated emission worse case was found in Adapter 1. Therefore only the test data of the mode was recorded in this report.

3. The antennas provided to the EUT, please refer to the following table:

Antenna No.	Transmitter Circuit	Antenna Gain(dBi)	Frequency range (GHz ~ GHz)	Antenna Type	Connector Type
1	Chain (0)	3.06	2.4~2.4835	Dipole	i-pex(MHF)
		2.68	5.15~5.25		
		2.55	5.725~5.85		
2	Chain (1)	3.06	2.4~2.4835	Dipole	i-pex(MHF)
		2.68	5.15~5.25		
		2.55	5.725~5.85		
3	Chain (2)	3.06	2.4~2.4835	Dipole	i-pex(MHF)
		2.68	5.15~5.25		
		2.55	5.725~5.85		
4	Chain (3)	3.06	2.4~2.4835	Dipole	i-pex(MHF)
		2.68	5.15~5.25		
		2.55	5.725~5.85		

4. The Directional gain table:

Frequency (MHz)	Max Gain (dBi)
2.4GHz band	8.49dBi (Nss=1) , 5.48dBi (Nss=2)
5GHz (UNII-1) band	8.15dBi (Nss=1), 5.14dBi (Nss=2)
5GHz (UNII-3) band	7.21dBi (Nss=1), 4.2dBi (Nss=2)

Note:

1. Non-TxBF mode & TxBF mode antenna gain refer to KDB 662911 F 2) f) (ii)

$$DirectionalGain = 10 \cdot \log \left[\frac{\sum_{j=1}^{N_{SS}} \left\{ \sum_{k=1}^{N_{ANT}} g_{j,k} \right\}^2}{N_{ANT}} \right]$$

where

Each antenna is driven by no more than one spatial stream;

N_{SS} = the number of independent spatial streams of data;

N_{ANT} = the total number of antennas

$g_{j,k} = 10^{G_k / 20}$ if the k th antenna is being fed by spatial stream j , or zero if it is not;

G_k is the gain in dBi of the k th antenna.

5. The EUT incorporates a MIMO function.

2.4GHz Band			
MODULATION MODE	DATA RATE (MCS)	TX & RX CONFIGURATION	
802.11b	1 ~ 11Mbps	4TX	4RX
802.11g	6 ~ 54Mbps	4TX	4RX
802.11n (HT20)	MCS 0~7	4TX	4RX
	MCS 8~15	4TX	4RX
	MCS16~23	4TX	4RX
	MCS 24~31	4TX	4RX
802.11n (HT40)	MCS 0~7	4TX	4RX
	MCS 8~15	4TX	4RX
	MCS16~23	4TX	4RX
	MCS 24~31	4TX	4RX
5GHz Band			
MODULATION MODE	DATA RATE (MCS)	TX & RX CONFIGURATION	
802.11a	6 ~ 54Mbps	4TX	4RX
802.11n (HT20)	MCS 0~7	4TX	4RX
	MCS 8~15	4TX	4RX
	MCS16~23	4TX	4RX
	MCS 24~31	4TX	4RX
802.11n (HT40)	MCS 0~7	4TX	4RX
	MCS 8~15	4TX	4RX
	MCS16~23	4TX	4RX
	MCS 24~31	4TX	4RX
802.11ac (VHT20)	MCS 0~8, Nss=1	4TX	4RX
	MCS 0~8, Nss=2	4TX	4RX
	MCS 0~9, Nss=3	4TX	4RX
	MCS 0~8, Nss=4	4TX	4RX
802.11ac (VHT40)	MCS 0~9, Nss=1	4TX	4RX
	MCS 0~9, Nss=2	4TX	4RX
	MCS 0~9, Nss=3	4TX	4RX
	MCS 0~9, Nss=4	4TX	4RX
802.11ac (VHT80)	MCS 0~9, Nss=1	4TX	4RX
	MCS 0~9, Nss=2	4TX	4RX
	MCS 0~9, Nss=3	4TX	4RX
	MCS 0~9, Nss=4	4TX	4RX

Note:

- All of modulation mode support beamforming function except 802.11a/b/g modulation mode.
- The modulation and bandwidth are similar for 802.11n mode for 20MHz (40MHz) and 802.11ac mode for 20MHz (40MHz), therefore investigated worst case to representative mode in test report. (Final test mode refer section 3.2.1)

6. The above EUT information is declared by manufacturer and for more detailed features description, please refer to the manufacturer's specifications or user's manual.

3.2 Description of Test Modes

FOR 5180 ~ 5240MHz

4 channels are provided for 802.11a, 802.11n (HT20), 802.11ac (VHT20):

Channel	Frequency	Channel	Frequency
36	5180MHz	44	5220MHz
40	5200MHz	48	5240MHz

2 channels are provided for 802.11n (HT40), 802.11ac (VHT40):

Channel	Frequency	Channel	Frequency
38	5190MHz	46	5230MHz

1 channel is provided for 802.11ac (VHT80):

Channel	Frequency
42	5210MHz

FOR 5745 ~ 5825MHz:

5 channels are provided for 802.11a, 802.11n (HT20), 802.11ac (VHT20):

Channel	Frequency	Channel	Frequency
149	5745MHz	161	5805MHz
153	5765MHz	165	5825MHz
157	5785MHz		

2 channels are provided for 802.11n (HT40), 802.11ac (VHT40):

Channel	Frequency	Channel	Frequency
151	5755MHz	159	5795MHz

1 channel is provided for 802.11ac (VHT80):

Channel	Frequency
155	5775MHz

3.2.1 Test Mode Applicability and Tested Channel Detail

EUT CONFIGURE MODE	APPLICABLE TO				DESCRIPTION
	RE \geq 1G	RE<1G	PLC	APCM	
1	√	√	√	√	With adapter 1
2	-	-	√	-	With adapter 2

Where **RE \geq 1G**: Radiated Emission above 1GHz & Bandedge Measurement
RE<1G: Radiated Emission below 1GHz
PLC: Power Line Conducted Emission
APCM: Antenna Port Conducted Measurement

NOTE:

1. The EUT had been pre-tested on the positioned of each 2 axis. The worst case was found when positioned on **X-plane**.
2. "-" means no effect.

Radiated Emission Test (Above 1GHz):

- Pre-Scan has been conducted to determine the worst-case mode from all possible combinations between available modulations, data rates and antenna ports (if EUT with antenna diversity architecture).
- Following channel(s) was (were) selected for the final test as listed below.

CDD Mode						
MODE	Freq. BAND (MHz)	AVAILABLE CHANNEL	TESTED CHANNEL	MODULATION TECHNOLOGY	MODULATION TYPE	DATA RATE (Mbps)
802.11a	5180-5240	36 to 48	36, 40, 48	OFDM	BPSK	6
802.11ac (VHT20)		36 to 48	36, 40, 48	OFDM	BPSK	6.5
802.11ac (VHT40)		38 to 46	38, 46	OFDM	BPSK	13.5
802.11ac (VHT80)		42	42	OFDM	BPSK	29.3
802.11a	5745-5825	149 to 165	149, 157, 165	OFDM	BPSK	6
802.11ac (VHT20)		149 to 165	149, 157, 165	OFDM	BPSK	6.5
802.11ac (VHT40)		151 to 159	151, 159	OFDM	BPSK	13.5
802.11ac (VHT80)		155	155	OFDM	BPSK	29.3

Radiated Emission Test (Below 1GHz):

- Pre-Scan has been conducted to determine the worst-case mode from all possible combinations between available modulations, data rates and antenna ports (if EUT with antenna diversity architecture).
- Following channel(s) was (were) selected for the final test as listed below.

CDD Mode						
MODE	Freq. BAND (MHz)	AVAILABLE CHANNEL	TESTED CHANNEL	MODULATION TECHNOLOGY	MODULATION TYPE	DATA RATE (Mbps)
802.11ac (VHT20)	5180-5240	36 to 48	157	OFDM	BPSK	6.5
	5745-5825	149 to 165				

Power Line Conducted Emission Test:

- Pre-Scan has been conducted to determine the worst-case mode from all possible combinations between available modulations, data rates and antenna ports (if EUT with antenna diversity architecture).
- Following channel(s) was (were) selected for the final test as listed below.

CDD Mode						
MODE	Freq. BAND (MHz)	AVAILABLE CHANNEL	TESTED CHANNEL	MODULATION TECHNOLOGY	MODULATION TYPE	DATA RATE (Mbps)
802.11ac (VHT20)	5180-5240	36 to 48	157	OFDM	BPSK	6.5
	5745-5825	149 to 165				

Antenna Port Conducted Measurement:

- This item includes all test value of each mode, but only includes spectrum plot of worst value of each mode.
- Pre-Scan has been conducted to determine the worst-case mode from all possible combinations between available modulations, data rates and antenna ports (if EUT with antenna diversity architecture).
- Following channel(s) was (were) selected for the final test as listed below.

CDD Mode						
MODE	Freq. BAND (MHz)	AVAILABLE CHANNEL	TESTED CHANNEL	MODULATION TECHNOLOGY	MODULATION TYPE	DATA RATE (Mbps)
802.11a	5180-5240	36 to 48	36, 40, 48	OFDM	BPSK	6
802.11ac (VHT20)		36 to 48	36, 40, 48	OFDM	BPSK	6.5
802.11ac (VHT40)		38 to 46	38, 46	OFDM	BPSK	13.5
802.11ac (VHT80)		42	42	OFDM	BPSK	29.3
802.11a	5745-5825	149 to 165	149, 157, 165	OFDM	BPSK	6
802.11ac (VHT20)		149 to 165	149, 157, 165	OFDM	BPSK	6.5
802.11ac (VHT40)		151 to 159	151, 159	OFDM	BPSK	13.5
802.11ac (VHT80)		155	155	OFDM	BPSK	29.3

Beamforming Mode Nss=1 (Output power only)

MODE	Freq. BAND (MHz)	AVAILABLE CHANNEL	TESTED CHANNEL	MODULATION TECHNOLOGY	MODULATION TYPE	DATA RATE (Mbps)
802.11ac (VHT20)	5180-5240	36 to 48	36, 40, 48	OFDM	BPSK	6.5
802.11ac (VHT40)		38 to 46	38, 46	OFDM	BPSK	13.5
802.11ac (VHT80)		42	42	OFDM	BPSK	29.3
802.11ac (VHT20)	5745-5825	149 to 165	149, 157, 165	OFDM	BPSK	6.5
802.11ac (VHT40)		151 to 159	151, 159	OFDM	BPSK	13.5
802.11ac (VHT80)		155	155	OFDM	BPSK	29.3

Beamforming Mode Nss=2 (Output power only)

MODE	Freq. BAND (MHz)	AVAILABLE CHANNEL	TESTED CHANNEL	MODULATION TECHNOLOGY	MODULATION TYPE	DATA RATE (Mbps)
802.11ac (VHT20)	5180-5240	36 to 48	36, 40, 48	OFDM	BPSK	6.5
802.11ac (VHT40)		38 to 46	38, 46	OFDM	BPSK	13.5
802.11ac (VHT80)		42	42	OFDM	BPSK	29.3
802.11ac (VHT20)	5745-5825	149 to 165	149, 157, 165	OFDM	BPSK	6.5
802.11ac (VHT40)		151 to 159	151, 159	OFDM	BPSK	13.5
802.11ac (VHT80)		155	155	OFDM	BPSK	29.3

Test Condition:

APPLICABLE TO	ENVIRONMENTAL CONDITIONS	INPUT POWER	TESTED BY
RE \geq 1G	26deg. C, 72%RH	120Vac, 60Hz	Gary Cheng
RE $<$ 1G	25deg. C, 66%RH	120Vac, 60Hz	Jyunchun Lin
PLC	25deg. C, 68%RH	120Vac, 60Hz	Andy Ho
APCM	25deg. C, 60%RH	120Vac, 60Hz	Gary Cheng

3.3 Duty Cycle of Test Signal

If duty cycle of test signal is $\geq 98\%$, duty factor is not required.

If duty cycle of test signal is $< 98\%$, duty factor is required

802.11a: Duty cycle = $2.061/2.087 = 0.988$

802.11ac (VHT20): Duty cycle = $1.926/1.95 = 0.988$

802.11ac (VHT40): Duty cycle = $0.956/0.974 = 0.982$

802.11ac (VHT80): Duty cycle = $0.46/0.48 = 0.958$, Duty factor = $10 * \log(1/0.958) = 0.18$

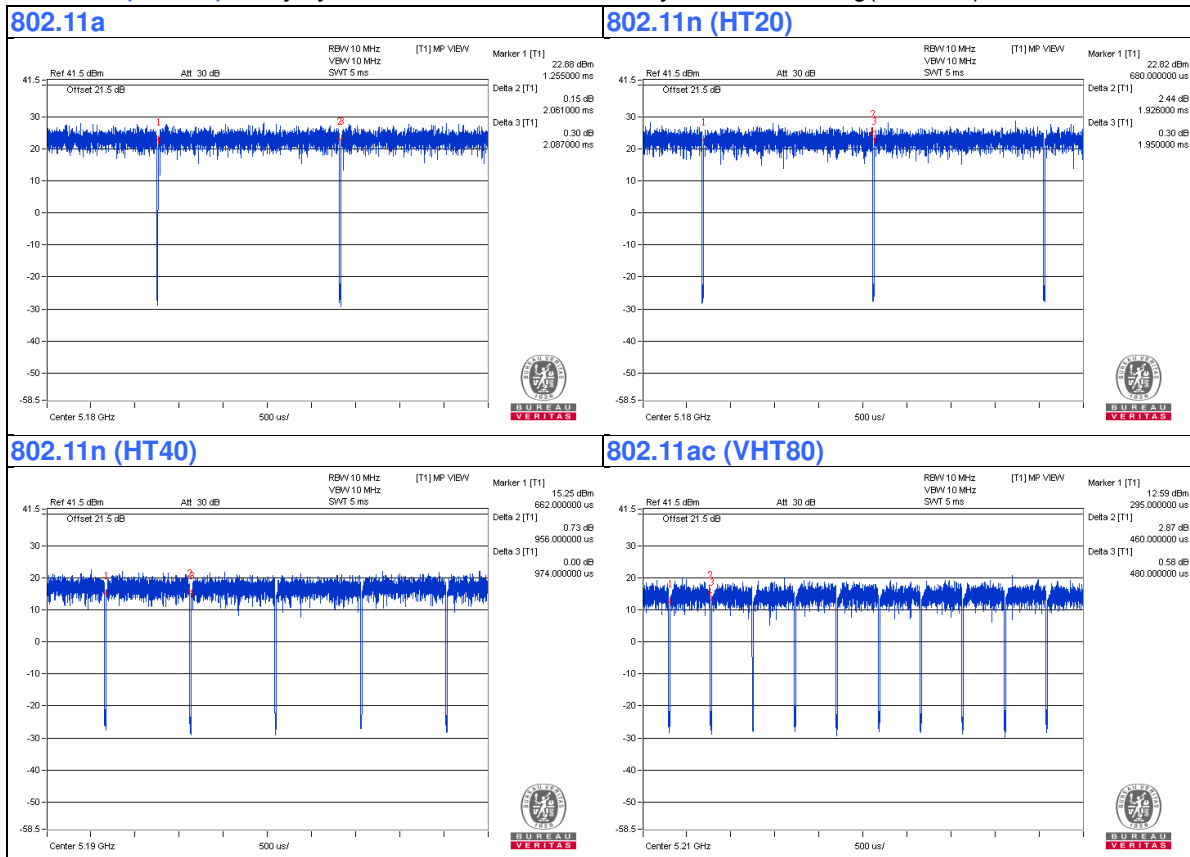

3.4 Description of Support Units

ID	Product	Brand	Model No.	Serial No.	FCC ID	Remarks
A.	Laptop	DELL	E5430	HYV4VY1	FCC DoC	Provided by Lab
B.	Laptop	LENOVO	E440	PF071LWC	NA	Provided by Lab
C.	USB Disk3.0	Transcend	16GB	NA	NA	Provided by Lab
D.	USB Disk3.0	Transcend	16GB	NA	NA	Provided by Lab

Note:

1. All power cords of the above support units are non-shielded (1.8m).

ID	Descriptions	Qty.	Length (m)	Shielding (Yes/No)	Cores (Qty.)	Remarks
1.	DC Cable	1	1.8	No	0	Supplied by client
2.	RJ-45 Cable	1	10	No	0	Provided by Lab
3.	RJ-45 Cable	1	10	No	0	Provided by Lab
4.	Coaxial Cable	1	10	Yes	0	Provided by Lab

3.4.1 Configuration of System under Test

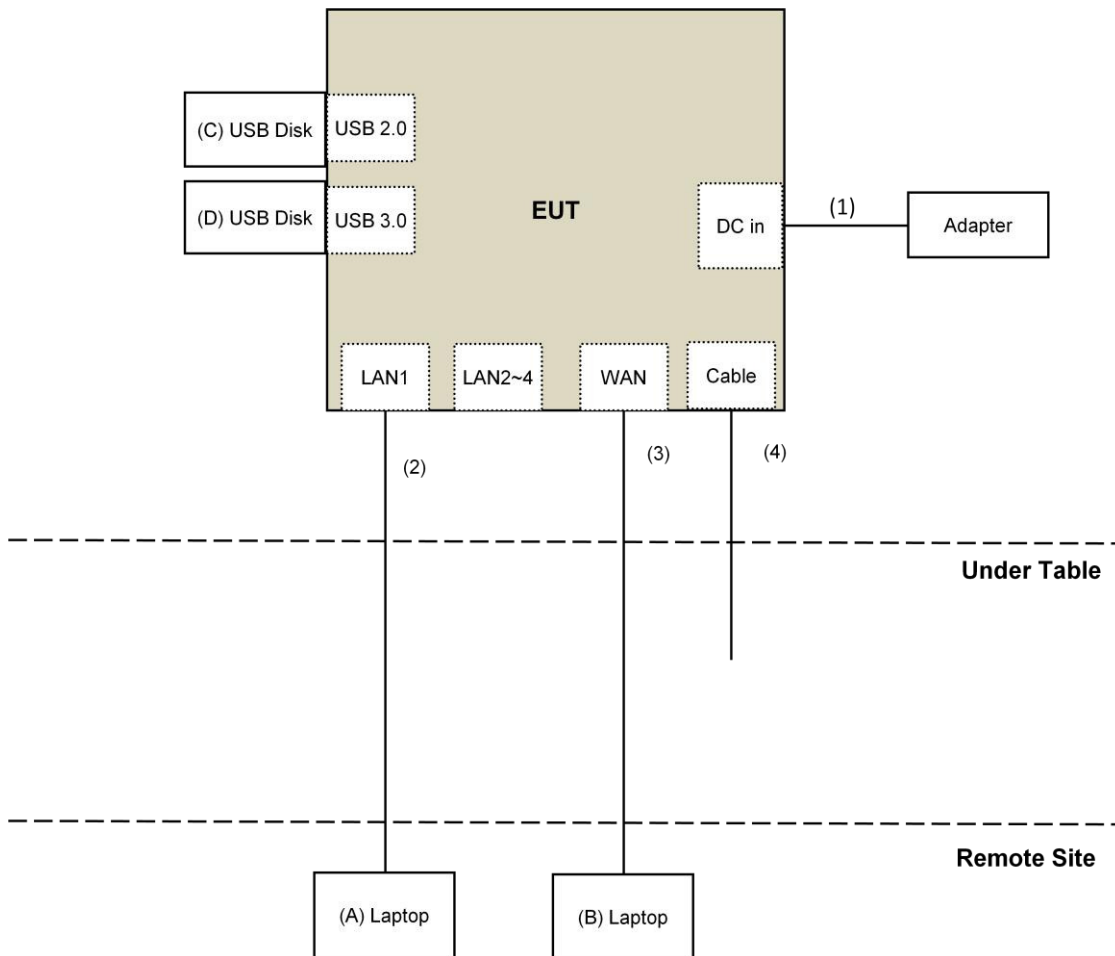

3.5 General Description of Applied Standard

The EUT is a RF Product. According to the specifications of the manufacturer, it must comply with the requirements of the following standards:

FCC Part 15, Subpart E (15.407)
KDB 789033 D02 General UNII Test Procedure New Rules v01r03
KDB 662911 D01 Multiple Transmitter Output v02r01
ANSI C63.10-2013

All test items have been performed and recorded as per the above standards.

NOTE: The EUT has been verified to comply with the requirements of FCC Part 15, Subpart B, Class B (DoC). The test report has been issued separately.

4 Test Types and Results

4.1 Radiated Emission and Bandedge Measurement

4.1.1 Limits of Radiated Emission and Bandedge Measurement

Radiated emissions which fall in the restricted bands must comply with the radiated emission limits specified as below table.

Frequencies (MHz)	Field Strength (microvolts/meter)	Measurement Distance (meters)
0.009 ~ 0.490	2400/F(kHz)	300
0.490 ~ 1.705	24000/F(kHz)	30
1.705 ~ 30.0	30	30
30 ~ 88	100	3
88 ~ 216	150	3
216 ~ 960	200	3
Above 960	500	3

NOTE:

1. The lower limit shall apply at the transition frequencies.
2. Emission level (dBuV/m) = 20 log Emission level (uV/m).
3. For frequencies above 1000MHz, the field strength limits are based on average detector, however, the peak field strength of any emission shall not exceed the maximum permitted average limits, specified above by more than 20dB under any condition of modulation.

Limits of unwanted emission out of the restricted bands

Applicable To		Limit	
789033 D02 General UNII Test Procedure New Rules v01r03		Field Strength at 3m	
		PK:74 (dBμV/m)	AV:54 (dBμV/m)
Frequency Band	Applicable To	EIRP Limit	Equivalent Field Strength at 3m
5150~5250 MHz	15.407(b)(1)	PK:-27 (dBm/MHz)	PK:68.2(dBμV/m)
5250~5350 MHz	15.407(b)(2)		
5470~5725 MHz	15.407(b)(3)		
5725~5850 MHz	<input checked="" type="checkbox"/> 15.407(b)(4)(i)	PK:-27 (dBm/MHz) ^{*1} PK:10 (dBm/MHz) ^{*2} PK:15.6 (dBm/MHz) ^{*3} PK:27 (dBm/MHz) ^{*4}	PK: 68.2(dBμV/m) ^{*1} PK:105.2 (dBμV/m) ^{*2} PK: 110.8(dBμV/m) ^{*3} PK:122.2 (dBμV/m) ^{*4}
	<input type="checkbox"/> 15.407(b)(4)(ii)	Emission limits in section 15.247(d)	
^{*1} beyond 75 MHz or more above of the band edge.		^{*2} below the band edge increasing linearly to 10 dBm/MHz at 25 MHz above.	
^{*3} below the band edge increasing linearly to a level of 15.6 dBm/MHz at 5 MHz above.		^{*4} from 5 MHz above or below the band edge increasing linearly to a level of 27 dBm/MHz at the band edge.	

Note:

The following formula is used to convert the equipment isotropic radiated power (eirp) to field strength:

$$E = \frac{1000000\sqrt{30P}}{3} \mu\text{V/m, where P is the eirp (Watts).}$$

4.1.2 Test Instruments

DESCRIPTION & MANUFACTURER	MODEL NO.	SERIAL NO.	CALIBRATED DATE	CALIBRATED UNTIL
Test Receiver Keysight	N9038A	MY54450088	July 20, 2016	July 19, 2017
Pre-Amplifier ^(*) EMCI	EMC001340	980142	Jan. 20, 2016	Jan. 19, 2018
Loop Antenna ^(*) Electro-Metrics	EM-6879	264	Dec. 16, 2014	Dec. 15, 2016
RF Cable	NA	LOOPCAB-001 LOOPCAB-002	Jan. 18, 2016	Jan. 17, 2017
Pre-Amplifier Mini-Circuits	ZFL-1000VH2 B	AMP-ZFL-01	Nov. 10, 2016	Nov. 09, 2017
Trilog Broadband Antenna SCHWARZBECK	VULB 9168	9168-406	Jan. 04, 2016	Jan. 03, 2017
RF Cable	8D	966-4-1 966-4-2 966-4-3	Apr. 02, 2016	Apr. 01, 2017
Fixed attenuator Mini-Circuits	UNAT-5+	PAD-3m-4-01	Oct. 05, 2016	Oct. 04, 2017
Horn_Antenna SCHWARZBECK	BBHA 9120D	9120D-783	Jan. 19, 2016	Jan. 18, 2017
Pre-Amplifier Agilent	8449B	3008A01922	Sep. 18, 2016	Sep. 17, 2017
RF Cable	EMC104-SM- SM-2000 EMC104-SM- SM-5000 EMC104-SM- SM-5000	150318 150323 150324	Mar. 30, 2016	Mar. 29, 2017
Pre-Amplifier EMCI	EMC184045	980143	Jan. 15, 2016	Jan. 14, 2017
Horn_Antenna SCHWARZBECK	BBHA 9170	BBHA9170608	Jan. 08, 2016	Jan. 07, 2017
RF Cable	SUCOFLEX 102	36432/2 36441/2	Jan. 16, 2016	Jan. 15, 2017
Software	ADT_Radiated _V8.7.08	NA	NA	NA
Antenna Tower & Turn Table Max-Full	MF-7802	MF780208410	NA	NA
Boresight Antenna Fixture	FBA-01	FBA-SIP02	NA	NA
Spectrum Analyzer R&S	FSV40	100964	June 28, 2016	June 27, 2017
Power meter Anritsu	ML2495A	0824006	May 26, 2016	May 25, 2017
Power sensor Anritsu	MA2411B	0738172	May 26, 2016	May 25, 2017

Note:

1. The calibration interval of the above test instruments is 12 months and the calibrations are traceable to NML/ROC and NIST/USA.
2. *The calibration interval of the above test instruments is 24 months and the calibrations are traceable to NML/ROC and NIST/USA.
3. Loop antenna was used for all emissions below 30 MHz.
4. The test was performed in 966 Chamber No. 4.
5. The FCC Site Registration No. is 292998
6. The CANADA Site Registration No. is 20331-2
7. Tested Date: Nov. 15 to 22, 2016

4.1.3 Test Procedure

For Radiated emission below 30MHz

- a. The EUT was placed on the top of a rotating table 0.8 meters above the ground at a 3 meter chamber room. The table was rotated 360 degrees to determine the position of the highest radiation.
- b. The EUT was set 3 meters away from the interference-receiving antenna, which was mounted on the top of a variable-height antenna tower.
- c. Both X and Y axes of the antenna are set to make the measurement.
- d. For each suspected emission, the EUT was arranged to its worst case and the rotatable table was turned from 0 degrees to 360 degrees to find the maximum reading.
- e. The test-receiver system was set to Quasi-Peak Detect Function and Specified Bandwidth with Maximum Hold Mode.

NOTE:

1. The resolution bandwidth and video bandwidth of test receiver/spectrum analyzer is 9kHz at frequency below 30MHz.

For Radiated emission above 30MHz

- a. The EUT was placed on the top of a rotating table 0.8 meters (for 30MHz ~ 1GHz) / 1.5 meters (for above 1GHz) above the ground at 3 meter chamber room for test. The table was rotated 360 degrees to determine the position of the highest radiation.
- b. The EUT was set 3 meters away from the interference-receiving antenna, which was mounted on the top of a variable-height antenna tower.
- c. The height of antenna is varied from one meter to four meters above the ground to determine the maximum value of the field strength. Both horizontal and vertical polarizations of the antenna are set to make the measurement.
- d. For each suspected emission, the EUT was arranged to its worst case and then the antenna was tuned to heights from 1 meter to 4 meters and the rotatable table was turned from 0 degrees to 360 degrees to find the maximum reading.
- e. The test-receiver system was set to quasi-peak detect function and specified bandwidth with maximum hold mode when the test frequency is below 1 GHz.
- f. The test-receiver system was set to peak and average detect function and specified bandwidth with maximum hold mode when the test frequency is above 1 GHz. If the peak reading value also meets average limit, measurement with the average detector is unnecessary.

Note:

1. The resolution bandwidth and video bandwidth of test receiver/spectrum analyzer is 120kHz for Quasi-peak detection (QP) at frequency below 1GHz.
2. The resolution bandwidth of test receiver/spectrum analyzer is 1 MHz and the video bandwidth is 3 MHz for Peak detection (PK) at frequency above 1GHz.
3. The resolution bandwidth of test receiver/spectrum analyzer is 1MHz and the video bandwidth is $\geq 1/T$ (Duty cycle < 98%) or 10Hz (Duty cycle $\geq 98\%$) for Average detection (AV) at frequency above 1GHz.
4. All modes of operation were investigated and the worst-case emissions are reported.

4.1.4 Deviation from Test Standard

No deviation.

4.1.5 Test Setup

For Radiated emission below 30MHz

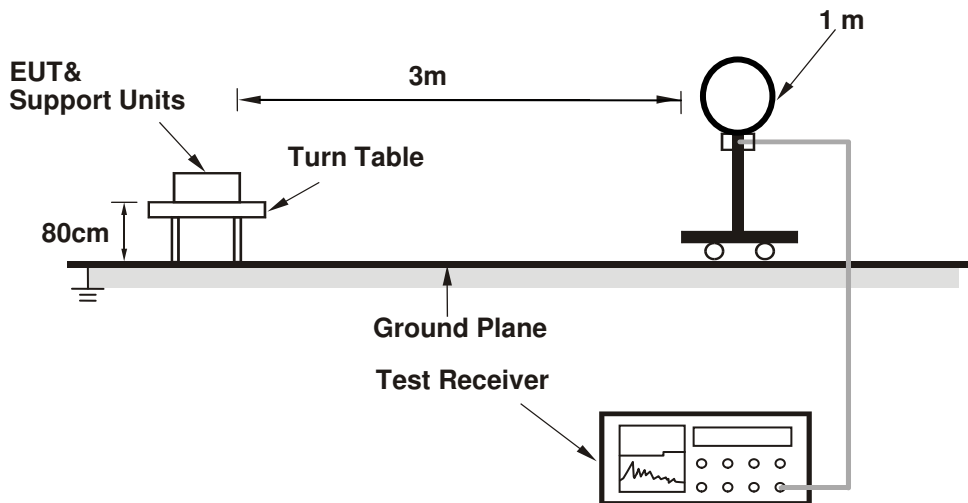

For Radiated emission 30MHz to 1GHz

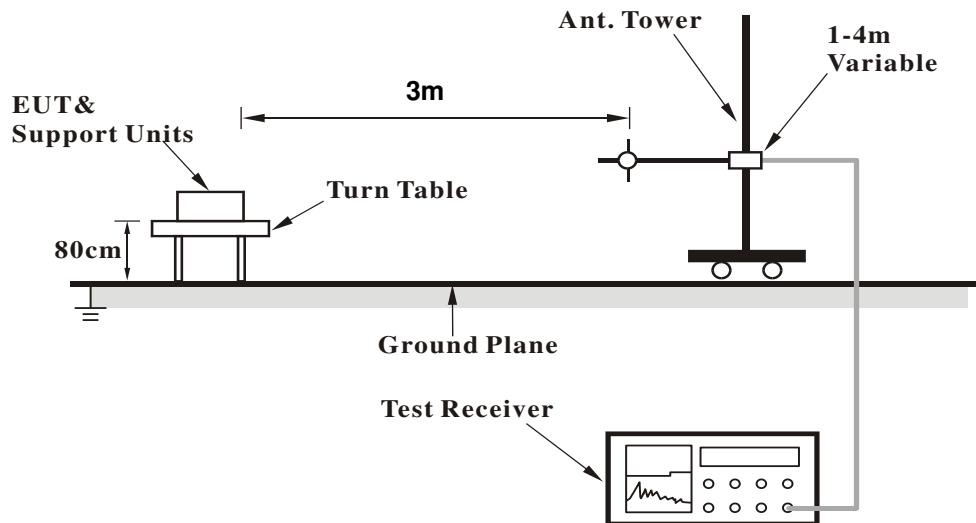

For Radiated emission above 1GHz

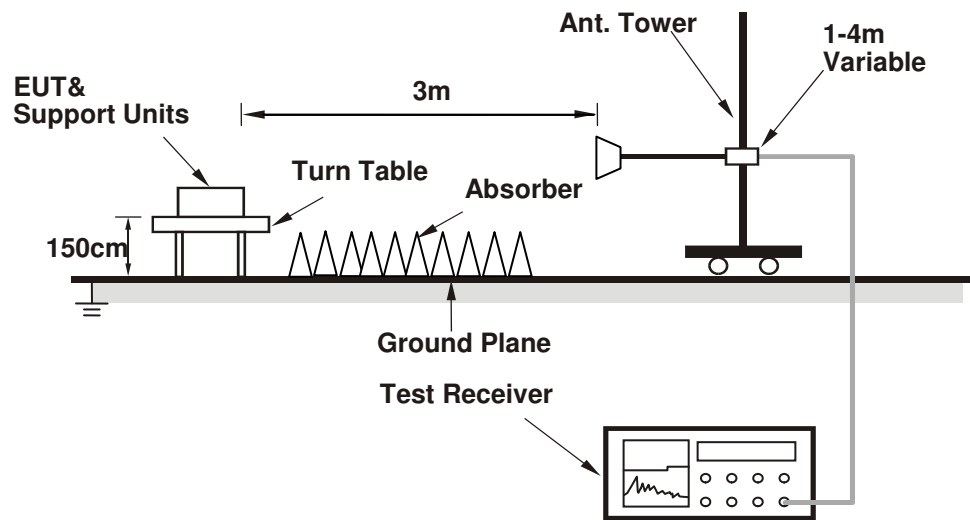

For the actual test configuration, please refer to the attached file (Test Setup Photo).

4.1.6 EUT Operating Condition

- a. Connected the EUT with the Laptop which is placed on remote site.
- b. Controlling software (MTool.exe Ver.2.0.3.2) has been activated to set the EUT on specific status.

4.1.7 Test Results

Above 1GHz Data

802.11a

CHANNEL	TX Channel 36	DETECTOR FUNCTION	Peak (PK)
FREQUENCY RANGE	1GHz ~ 40GHz		Average (AV)

ANTENNA POLARITY & TEST DISTANCE: HORIZONTAL AT 3 M

NO.	FREQ. (MHz)	EMISSION LEVEL (dBuV/m)	LIMIT (dBuV/m)	MARGIN (dB)	ANTENNA HEIGHT (m)	TABLE ANGLE (Degree)	RAW VALUE (dBuV)	CORRECTION FACTOR (dB/m)
1	5150.00	65.4 PK	74.0	-8.6	3.15 H	208	63.9	1.5
2	5150.00	50.0 AV	54.0	-4.0	3.15 H	208	48.5	1.5
3	*5180.00	105.9 PK			3.15 H	208	104.3	1.6
4	*5180.00	95.0 AV			3.15 H	208	93.4	1.6
5	#10360.00	67.7 PK	74.0	-6.3	1.56 H	215	56.2	11.5
6	#10360.00	52.5 AV	54.0	-1.5	1.56 H	215	41.0	11.5
7	15540.00	52.8 PK	74.0	-21.2	1.91 H	171	39.7	13.1
8	15540.00	41.6 AV	54.0	-12.4	1.91 H	171	28.5	13.1

ANTENNA POLARITY & TEST DISTANCE: VERTICAL AT 3 M

NO.	FREQ. (MHz)	EMISSION LEVEL (dBuV/m)	LIMIT (dBuV/m)	MARGIN (dB)	ANTENNA HEIGHT (m)	TABLE ANGLE (Degree)	RAW VALUE (dBuV)	CORRECTION FACTOR (dB/m)
1	5150.00	67.8 PK	74.0	-6.2	3.80 V	186	66.3	1.5
2	5150.00	52.4 AV	54.0	-1.6	3.80 V	186	50.9	1.5
3	*5180.00	115.2 PK			3.90 V	360	113.6	1.6
4	*5180.00	104.3 AV			3.90 V	360	102.7	1.6
5	#10360.00	62.1 PK	74.0	-11.9	3.79 V	285	50.6	11.5
6	#10360.00	46.7 AV	54.0	-7.3	3.79 V	285	35.2	11.5
7	15540.00	52.4 PK	74.0	-21.6	2.20 V	356	39.3	13.1
8	15540.00	42.1 AV	54.0	-11.9	2.20 V	356	29.0	13.1

REMARKS:

1. Emission Level(dBuV/m) = Raw Value(dBuV) + Correction Factor(dB/m)
2. Correction Factor(dB/m) = Antenna Factor(dB/m) + Cable Factor(dB) – Pre-Amplifier Factor(dB)
3. The other emission levels were very low against the limit.
4. Margin value = Emission Level – Limit value
5. " * ": Fundamental frequency.
6. " # ": The radiated frequency is out of the restricted band.

CHANNEL	TX Channel 40	DETECTOR FUNCTION	Peak (PK)
FREQUENCY RANGE	1GHz ~ 40GHz		Average (AV)

ANTENNA POLARITY & TEST DISTANCE: HORIZONTAL AT 3 M

NO.	FREQ. (MHz)	EMISSION LEVEL (dBuV/m)	LIMIT (dBuV/m)	MARGIN (dB)	ANTENNA HEIGHT (m)	TABLE ANGLE (Degree)	RAW VALUE (dBuV)	CORRECTION FACTOR (dB/m)
1	5150.00	49.6 PK	74.0	-24.4	3.17 H	205	48.1	1.5
2	5150.00	38.4 AV	54.0	-15.6	3.17 H	205	36.9	1.5
3	*5200.00	107.1 PK			3.17 H	205	105.4	1.7
4	*5200.00	96.3 AV			3.17 H	205	94.6	1.7
5	#10400.00	66.3 PK	74.0	-7.7	1.52 H	218	54.7	11.6
6	#10400.00	51.0 AV	54.0	-3.0	1.52 H	218	39.4	11.6
7	15600.00	51.4 PK	74.0	-22.6	1.85 H	183	38.3	13.1
8	15600.00	40.0 AV	54.0	-14.0	1.85 H	183	26.9	13.1

ANTENNA POLARITY & TEST DISTANCE: VERTICAL AT 3 M

NO.	FREQ. (MHz)	EMISSION LEVEL (dBuV/m)	LIMIT (dBuV/m)	MARGIN (dB)	ANTENNA HEIGHT (m)	TABLE ANGLE (Degree)	RAW VALUE (dBuV)	CORRECTION FACTOR (dB/m)
1	5150.00	60.0 PK	74.0	-14.0	3.86 V	187	58.5	1.5
2	5150.00	46.6 AV	54.0	-7.4	3.86 V	187	45.1	1.5
3	*5200.00	116.4 PK			3.86 V	187	114.7	1.7
4	*5200.00	105.6 AV			3.86 V	187	103.9	1.7
5	#10400.00	63.3 PK	74.0	-10.7	3.73 V	278	51.7	11.6
6	#10400.00	49.7 AV	54.0	-4.3	3.73 V	278	38.1	11.6
7	15600.00	50.5 PK	74.0	-23.5	2.15 V	347	37.4	13.1
8	15600.00	40.5 AV	54.0	-13.5	2.15 V	347	27.4	13.1

REMARKS:

1. Emission Level(dBuV/m) = Raw Value(dBuV) + Correction Factor(dB/m)
2. Correction Factor(dB/m) = Antenna Factor(dB/m) + Cable Factor(dB) – Pre-Amplifier Factor(dB)
3. The other emission levels were very low against the limit.
4. Margin value = Emission Level – Limit value
5. " * ": Fundamental frequency.
6. " # ": The radiated frequency is out of the restricted band.

CHANNEL	TX Channel 48	DETECTOR FUNCTION	Peak (PK)
FREQUENCY RANGE	1GHz ~ 40GHz		Average (AV)

ANTENNA POLARITY & TEST DISTANCE: HORIZONTAL AT 3 M

NO.	FREQ. (MHz)	EMISSION LEVEL (dBuV/m)	LIMIT (dBuV/m)	MARGIN (dB)	ANTENNA HEIGHT (m)	TABLE ANGLE (Degree)	RAW VALUE (dBuV)	CORRECTION FACTOR (dB/m)
1	5150.00	54.5 PK	74.0	-19.5	3.14 H	194	53.0	1.5
2	5150.00	41.9 AV	54.0	-12.1	3.14 H	194	40.4	1.5
3	*5240.00	106.5 PK			3.14 H	194	104.9	1.6
4	*5240.00	96.3 AV			3.14 H	194	94.7	1.6
5	5394.80	54.8 PK	74.0	-19.2	3.14 H	194	52.7	2.1
6	5394.80	41.6 AV	54.0	-12.4	3.14 H	194	39.5	2.1
7	#10480.00	66.0 PK	74.0	-8.0	1.55 H	222	54.0	12.0
8	#10480.00	51.0 AV	54.0	-3.0	1.55 H	222	39.0	12.0
9	15720.00	51.1 PK	74.0	-22.9	1.80 H	181	37.9	13.2
10	15720.00	40.0 AV	54.0	-14.0	1.80 H	181	26.8	13.2

ANTENNA POLARITY & TEST DISTANCE: VERTICAL AT 3 M

NO.	FREQ. (MHz)	EMISSION LEVEL (dBuV/m)	LIMIT (dBuV/m)	MARGIN (dB)	ANTENNA HEIGHT (m)	TABLE ANGLE (Degree)	RAW VALUE (dBuV)	CORRECTION FACTOR (dB/m)
1	5150.00	56.5 PK	74.0	-17.5	3.69 V	187	55.0	1.5
2	5150.00	44.0 AV	54.0	-10.0	3.69 V	187	42.5	1.5
3	*5240.00	115.8 PK			3.69 V	187	114.2	1.6
4	*5240.00	105.6 AV			3.69 V	187	104.0	1.6
5	5394.80	56.9 PK	74.0	-17.1	3.69 V	187	54.8	2.1
6	5394.80	43.9 AV	54.0	-10.1	3.69 V	187	41.8	2.1
7	#10480.00	63.1 PK	74.0	-10.9	3.72 V	278	51.1	12.0
8	#10480.00	49.6 AV	54.0	-4.4	3.72 V	278	37.6	12.0
9	15720.00	50.5 PK	74.0	-23.5	2.21 V	357	37.3	13.2
10	15720.00	40.3 AV	54.0	-13.7	2.21 V	357	27.1	13.2

REMARKS:

1. Emission Level(dBuV/m) = Raw Value(dBuV) + Correction Factor(dB/m)
2. Correction Factor(dB/m) = Antenna Factor(dB/m) + Cable Factor(dB) – Pre-Amplifier Factor(dB)
3. The other emission levels were very low against the limit.
4. Margin value = Emission Level – Limit value
5. " * ": Fundamental frequency.
6. " # ": The radiated frequency is out of the restricted band.

CHANNEL	TX Channel 149	DETECTOR FUNCTION	Peak (PK)
FREQUENCY RANGE	1GHz ~ 40GHz		Average (AV)

ANTENNA POLARITY & TEST DISTANCE: HORIZONTAL AT 3 M

NO.	FREQ. (MHz)	EMISSION LEVEL (dBuV/m)	LIMIT (dBuV/m)	MARGIN (dB)	ANTENNA HEIGHT (m)	TABLE ANGLE (Degree)	RAW VALUE (dBuV)	CORRECTION FACTOR (dB/m)
1	#5615.55	58.4 PK	68.2	-9.8	3.10 H	217	55.8	2.6
2	*5745.00	108.6 PK			3.10 H	217	105.9	2.7
3	*5745.00	98.2 AV			3.10 H	217	95.5	2.7
4	#5940.45	59.4 PK	68.2	-8.8	3.10 H	217	56.3	3.1
5	11490.00	62.5 PK	74.0	-11.5	1.75 H	232	49.1	13.4
6	11490.00	48.6 AV	54.0	-5.4	1.75 H	232	35.2	13.4
7	#17235.00	55.5 PK	74.0	-18.5	1.84 H	196	37.2	18.3
8	#17235.00	42.7 AV	54.0	-11.3	1.84 H	196	24.4	18.3

ANTENNA POLARITY & TEST DISTANCE: VERTICAL AT 3 M

NO.	FREQ. (MHz)	EMISSION LEVEL (dBuV/m)	LIMIT (dBuV/m)	MARGIN (dB)	ANTENNA HEIGHT (m)	TABLE ANGLE (Degree)	RAW VALUE (dBuV)	CORRECTION FACTOR (dB/m)
1	#5642.15	60.2 PK	68.2	-8.0	2.81 V	189	57.6	2.6
2	*5745.00	117.9 PK			2.82 V	189	115.2	2.7
3	*5745.00	107.5 AV			2.82 V	189	104.8	2.7
4	#5992.23	61.4 PK	68.2	-6.8	2.81 V	189	58.0	3.4
5	11490.00	64.2 PK	74.0	-9.8	3.98 V	34	50.8	13.4
6	11490.00	50.6 AV	54.0	-3.4	3.98 V	34	37.2	13.4
7	#17235.00	57.6 PK	74.0	-16.4	3.80 V	207	39.3	18.3
8	#17235.00	44.8 AV	54.0	-9.2	3.80 V	207	26.5	18.3

REMARKS:

1. Emission Level(dBuV/m) = Raw Value(dBuV) + Correction Factor(dB/m)
2. Correction Factor(dB/m) = Antenna Factor(dB/m) + Cable Factor(dB) – Pre-Amplifier Factor(dB)
3. The other emission levels were very low against the limit.
4. Margin value = Emission Level – Limit value
5. " * ": Fundamental frequency.
6. " # ": The radiated frequency is out of the restricted band.

CHANNEL	TX Channel 157	DETECTOR FUNCTION	Peak (PK)
FREQUENCY RANGE	1GHz ~ 40GHz		Average (AV)

ANTENNA POLARITY & TEST DISTANCE: HORIZONTAL AT 3 M

NO.	FREQ. (MHz)	EMISSION LEVEL (dBuV/m)	LIMIT (dBuV/m)	MARGIN (dB)	ANTENNA HEIGHT (m)	TABLE ANGLE (Degree)	RAW VALUE (dBuV)	CORRECTION FACTOR (dB/m)
1	#5613.65	58.2 PK	68.2	-10.0	3.06 H	218	55.6	2.6
2	*5785.00	109.7 PK			3.06 H	218	107.0	2.7
3	*5785.00	99.0 AV			3.06 H	218	96.3	2.7
4	#5963.73	59.0 PK	68.2	-9.2	3.06 H	218	55.8	3.2
5	11570.00	64.9 PK	74.0	-9.1	1.76 H	238	51.8	13.1
6	11570.00	52.8 AV	54.0	-1.2	1.76 H	238	39.7	13.1
7	#17355.00	57.2 PK	74.0	-16.8	1.77 H	165	38.4	18.8
8	#17355.00	45.4 AV	54.0	-8.6	1.77 H	165	26.6	18.8

ANTENNA POLARITY & TEST DISTANCE: VERTICAL AT 3 M

NO.	FREQ. (MHz)	EMISSION LEVEL (dBuV/m)	LIMIT (dBuV/m)	MARGIN (dB)	ANTENNA HEIGHT (m)	TABLE ANGLE (Degree)	RAW VALUE (dBuV)	CORRECTION FACTOR (dB/m)
1	#5550.00	59.5 PK	68.2	-8.7	2.62 V	195	57.0	2.5
2	*5785.00	118.8 PK			2.62 V	195	116.1	2.7
3	*5785.00	108.2 AV			2.62 V	195	105.5	2.7
4	#6018.82	60.4 PK	68.2	-7.8	2.62 V	195	57.0	3.4
5	11570.00	68.7 PK	74.0	-5.3	2.27 V	43	55.6	13.1
6	11570.00	53.6 AV	54.0	-0.4	2.27 V	43	40.5	13.1
7	#17355.00	57.3 PK	74.0	-16.7	1.88 V	128	38.5	18.8
8	#17355.00	44.6 AV	54.0	-9.4	1.88 V	128	25.8	18.8

REMARKS:

1. Emission Level(dBuV/m) = Raw Value(dBuV) + Correction Factor(dB/m)
2. Correction Factor(dB/m) = Antenna Factor(dB/m) + Cable Factor(dB) – Pre-Amplifier Factor(dB)
3. The other emission levels were very low against the limit.
4. Margin value = Emission Level – Limit value
5. " * ": Fundamental frequency.
6. " # ": The radiated frequency is out of the restricted band.

CHANNEL	TX Channel 165	DETECTOR FUNCTION	Peak (PK)
FREQUENCY RANGE	1GHz ~ 40GHz		Average (AV)

ANTENNA POLARITY & TEST DISTANCE: HORIZONTAL AT 3 M

NO.	FREQ. (MHz)	EMISSION LEVEL (dBuV/m)	LIMIT (dBuV/m)	MARGIN (dB)	ANTENNA HEIGHT (m)	TABLE ANGLE (Degree)	RAW VALUE (dBuV)	CORRECTION FACTOR (dB/m)
1	#5621.73	59.1 PK	68.2	-9.1	2.94 H	217	56.5	2.6
2	*5825.00	107.5 PK			2.94 H	217	104.8	2.7
3	*5825.00	96.7 AV			2.94 H	217	94.0	2.7
4	#5985.10	58.6 PK	68.2	-9.6	2.94 H	217	55.3	3.3
5	11650.00	67.6 PK	74.0	-6.4	1.74 H	212	54.5	13.1
6	11650.00	53.9 AV	54.0	-0.1	1.74 H	212	40.8	13.1
7	#17475.00	57.2 PK	74.0	-16.8	1.72 H	166	38.0	19.2
8	#17475.00	45.6 AV	54.0	-8.4	1.72 H	166	26.4	19.2

ANTENNA POLARITY & TEST DISTANCE: VERTICAL AT 3 M

NO.	FREQ. (MHz)	EMISSION LEVEL (dBuV/m)	LIMIT (dBuV/m)	MARGIN (dB)	ANTENNA HEIGHT (m)	TABLE ANGLE (Degree)	RAW VALUE (dBuV)	CORRECTION FACTOR (dB/m)
1	#5554.75	59.6 PK	68.2	-8.6	2.64 V	177	57.1	2.5
2	*5825.00	116.6 PK			2.64 V	177	113.9	2.7
3	*5825.00	105.8 AV			2.64 V	177	103.1	2.7
4	#6012.65	60.6 PK	68.2	-7.6	2.64 V	177	57.2	3.4
5	11650.00	70.0 PK	74.0	-4.0	2.27 V	45	56.9	13.1
6	11650.00	53.9 AV	54.0	-0.1	2.27 V	45	40.8	13.1
7	#17475.00	57.2 PK	74.0	-16.8	1.87 V	141	38.0	19.2
8	#17475.00	44.3 AV	54.0	-9.7	1.87 V	141	25.1	19.2

REMARKS:

1. Emission Level(dBuV/m) = Raw Value(dBuV) + Correction Factor(dB/m)
2. Correction Factor(dB/m) = Antenna Factor(dB/m) + Cable Factor(dB) – Pre-Amplifier Factor(dB)
3. The other emission levels were very low against the limit.
4. Margin value = Emission Level – Limit value
5. " * ": Fundamental frequency.
6. " # ": The radiated frequency is out of the restricted band.

802.11ac (VHT20)

CHANNEL	TX Channel 36	DETECTOR FUNCTION	Peak (PK)
FREQUENCY RANGE	1GHz ~ 40GHz		Average (AV)

ANTENNA POLARITY & TEST DISTANCE: HORIZONTAL AT 3 M

NO.	FREQ. (MHz)	EMISSION LEVEL (dBuV/m)	LIMIT (dBuV/m)	MARGIN (dB)	ANTENNA HEIGHT (m)	TABLE ANGLE (Degree)	RAW VALUE (dBuV)	CORRECTION FACTOR (dB/m)
1	5150.00	63.8 PK	74.0	-10.2	3.02 H	223	62.3	1.5
2	5150.00	50.7 AV	54.0	-3.3	3.02 H	223	49.2	1.5
3	*5180.00	106.5 PK			3.02 H	223	104.9	1.6
4	*5180.00	95.9 AV			3.02 H	223	94.3	1.6
5	#10360.00	67.4 PK	74.0	-6.6	1.50 H	210	55.9	11.5
6	#10360.00	51.9 AV	54.0	-2.1	1.50 H	210	40.4	11.5
7	15540.00	51.6 PK	74.0	-22.4	1.88 H	178	38.5	13.1
8	15540.00	40.1 AV	54.0	-13.9	1.88 H	178	27.0	13.1

ANTENNA POLARITY & TEST DISTANCE: VERTICAL AT 3 M

NO.	FREQ. (MHz)	EMISSION LEVEL (dBuV/m)	LIMIT (dBuV/m)	MARGIN (dB)	ANTENNA HEIGHT (m)	TABLE ANGLE (Degree)	RAW VALUE (dBuV)	CORRECTION FACTOR (dB/m)
1	5150.00	65.9 PK	74.0	-8.1	2.59 V	204	64.4	1.5
2	5150.00	52.8 AV	54.0	-1.2	2.59 V	204	51.3	1.5
3	*5180.00	115.8 PK			2.59 V	204	114.2	1.6
4	*5180.00	105.2 AV			2.59 V	204	103.6	1.6
5	#10360.00	62.6 PK	74.0	-11.4	3.74 V	271	51.1	11.5
6	#10360.00	48.8 AV	54.0	-5.2	3.74 V	271	37.3	11.5
7	15540.00	49.9 PK	74.0	-24.1	2.14 V	354	36.8	13.1
8	15540.00	39.5 AV	54.0	-14.5	2.14 V	354	26.4	13.1

REMARKS:

- Emission Level(dBuV/m) = Raw Value(dBuV) + Correction Factor(dB/m)
- Correction Factor(dB/m) = Antenna Factor(dB/m) + Cable Factor(dB) – Pre-Amplifier Factor(dB)
- The other emission levels were very low against the limit.
- Margin value = Emission Level – Limit value
- " * ": Fundamental frequency.
- " # ": The radiated frequency is out of the restricted band.

CHANNEL	TX Channel 40	DETECTOR FUNCTION	Peak (PK)
FREQUENCY RANGE	1GHz ~ 40GHz		Average (AV)

ANTENNA POLARITY & TEST DISTANCE: HORIZONTAL AT 3 M

NO.	FREQ. (MHz)	EMISSION LEVEL (dBuV/m)	LIMIT (dBuV/m)	MARGIN (dB)	ANTENNA HEIGHT (m)	TABLE ANGLE (Degree)	RAW VALUE (dBuV)	CORRECTION FACTOR (dB/m)
1	5150.00	56.6 PK	74.0	-17.4	2.98 H	229	55.1	1.5
2	5150.00	45.5 AV	54.0	-8.5	2.98 H	229	44.0	1.5
3	*5200.00	108.0 PK			2.98 H	229	106.3	1.7
4	*5200.00	97.8 AV			2.98 H	229	96.1	1.7
5	5360.00	52.2 PK	74.0	-21.8	2.98 H	229	50.2	2.0
6	5360.00	41.7 AV	54.0	-12.3	2.98 H	229	39.7	2.0
7	#10400.00	66.8 PK	74.0	-7.2	1.51 H	222	55.2	11.6
8	#10400.00	51.5 AV	54.0	-2.5	1.51 H	222	39.9	11.6
9	15600.00	51.7 PK	74.0	-22.3	1.85 H	189	38.6	13.1
10	15600.00	40.3 AV	54.0	-13.7	1.85 H	189	27.2	13.1

ANTENNA POLARITY & TEST DISTANCE: VERTICAL AT 3 M

NO.	FREQ. (MHz)	EMISSION LEVEL (dBuV/m)	LIMIT (dBuV/m)	MARGIN (dB)	ANTENNA HEIGHT (m)	TABLE ANGLE (Degree)	RAW VALUE (dBuV)	CORRECTION FACTOR (dB/m)
1	5150.00	58.7 PK	74.0	-15.3	2.72 V	206	57.2	1.5
2	5150.00	47.6 AV	54.0	-6.4	2.72 V	206	46.1	1.5
3	*5200.00	117.3 PK			2.72 V	206	115.6	1.7
4	*5200.00	107.1 AV			2.72 V	206	105.4	1.7
5	5360.00	54.3 PK	74.0	-19.7	2.72 V	206	52.3	2.0
6	5360.00	43.8 AV	54.0	-10.2	2.72 V	206	41.8	2.0
7	#10400.00	62.1 PK	74.0	-11.9	3.71 V	269	50.5	11.6
8	#10400.00	48.4 AV	54.0	-5.6	3.71 V	269	36.8	11.6
9	15600.00	49.3 PK	74.0	-24.7	2.13 V	350	36.2	13.1
10	15600.00	39.1 AV	54.0	-14.9	2.13 V	350	26.0	13.1

REMARKS:

1. Emission Level(dBuV/m) = Raw Value(dBuV) + Correction Factor(dB/m)
2. Correction Factor(dB/m) = Antenna Factor(dB/m) + Cable Factor(dB) – Pre-Amplifier Factor(dB)
3. The other emission levels were very low against the limit.
4. Margin value = Emission Level – Limit value
5. " * ": Fundamental frequency.
6. " # ": The radiated frequency is out of the restricted band.

CHANNEL	TX Channel 48	DETECTOR FUNCTION	Peak (PK)
FREQUENCY RANGE	1GHz ~ 40GHz		Average (AV)

ANTENNA POLARITY & TEST DISTANCE: HORIZONTAL AT 3 M

NO.	FREQ. (MHz)	EMISSION LEVEL (dBuV/m)	LIMIT (dBuV/m)	MARGIN (dB)	ANTENNA HEIGHT (m)	TABLE ANGLE (Degree)	RAW VALUE (dBuV)	CORRECTION FACTOR (dB/m)
1	*5240.00	108.3 PK			2.97 H	222	106.7	1.6
2	*5240.00	97.1 AV			2.97 H	222	95.5	1.6
3	5350.00	55.2 PK	74.0	-18.8	2.97 H	222	53.3	1.9
4	5350.00	42.5 AV	54.0	-11.5	2.97 H	222	40.6	1.9
5	#10480.00	66.3 PK	74.0	-7.7	1.46 H	219	54.3	12.0
6	#10480.00	51.3 AV	54.0	-2.7	1.46 H	219	39.3	12.0
7	15720.00	51.2 PK	74.0	-22.8	1.80 H	194	38.0	13.2
8	15720.00	40.0 AV	54.0	-14.0	1.80 H	194	26.8	13.2

ANTENNA POLARITY & TEST DISTANCE: VERTICAL AT 3 M

NO.	FREQ. (MHz)	EMISSION LEVEL (dBuV/m)	LIMIT (dBuV/m)	MARGIN (dB)	ANTENNA HEIGHT (m)	TABLE ANGLE (Degree)	RAW VALUE (dBuV)	CORRECTION FACTOR (dB/m)
1	*5240.00	117.6 PK			2.79 V	154	116.0	1.6
2	*5240.00	106.4 AV			2.79 V	154	104.8	1.6
3	5350.00	57.3 PK	74.0	-16.7	2.79 V	154	55.4	1.9
4	5350.00	44.6 AV	54.0	-9.4	2.79 V	154	42.7	1.9
5	#10480.00	61.9 PK	74.0	-12.1	3.73 V	279	49.9	12.0
6	#10480.00	48.2 AV	54.0	-5.8	3.73 V	279	36.2	12.0
7	15720.00	49.8 PK	74.0	-24.2	2.09 V	346	36.6	13.2
8	15720.00	39.4 AV	54.0	-14.6	2.09 V	346	26.2	13.2

REMARKS:

1. Emission Level(dBuV/m) = Raw Value(dBuV) + Correction Factor(dB/m)
2. Correction Factor(dB/m) = Antenna Factor(dB/m) + Cable Factor(dB) – Pre-Amplifier Factor(dB)
3. The other emission levels were very low against the limit.
4. Margin value = Emission Level – Limit value
5. " * ": Fundamental frequency.
6. " # ": The radiated frequency is out of the restricted band.

CHANNEL	TX Channel 149	DETECTOR FUNCTION	Peak (PK)
FREQUENCY RANGE	1GHz ~ 40GHz		Average (AV)

ANTENNA POLARITY & TEST DISTANCE: HORIZONTAL AT 3 M

NO.	FREQ. (MHz)	EMISSION LEVEL (dBuV/m)	LIMIT (dBuV/m)	MARGIN (dB)	ANTENNA HEIGHT (m)	TABLE ANGLE (Degree)	RAW VALUE (dBuV)	CORRECTION FACTOR (dB/m)
1	#5586.10	58.8 PK	68.2	-9.4	3.06 H	232	56.3	2.5
2	*5745.00	110.0 PK			3.06 H	232	107.3	2.7
3	*5745.00	99.3 AV			3.06 H	232	96.6	2.7
4	#6000.77	60.0 PK	68.2	-8.2	3.06 H	232	56.6	3.4
5	11490.00	61.7 PK	74.0	-12.3	1.73 H	235	48.3	13.4
6	11490.00	46.8 AV	54.0	-7.2	1.73 H	235	33.4	13.4
7	#17235.00	56.8 PK	74.0	-17.2	1.72 H	166	38.5	18.3
8	#17235.00	45.1 AV	54.0	-8.9	1.72 H	166	26.8	18.3

ANTENNA POLARITY & TEST DISTANCE: VERTICAL AT 3 M

NO.	FREQ. (MHz)	EMISSION LEVEL (dBuV/m)	LIMIT (dBuV/m)	MARGIN (dB)	ANTENNA HEIGHT (m)	TABLE ANGLE (Degree)	RAW VALUE (dBuV)	CORRECTION FACTOR (dB/m)
1	#5643.57	61.1 PK	68.2	-7.1	2.65 V	179	58.5	2.6
2	*5745.00	118.6 PK			2.65 V	179	115.9	2.7
3	*5745.00	108.3 AV			2.65 V	179	105.6	2.7
4	#5983.20	60.0 PK	68.2	-8.2	2.65 V	179	56.7	3.3
5	11490.00	58.5 PK	74.0	-15.5	1.98 V	234	45.1	13.4
6	11490.00	49.2 AV	54.0	-4.8	1.98 V	234	35.8	13.4
7	#17235.00	49.9 PK	74.0	-24.1	2.05 V	333	31.6	18.3
8	#17235.00	39.4 AV	54.0	-14.6	2.05 V	333	21.1	18.3

REMARKS:

1. Emission Level(dBuV/m) = Raw Value(dBuV) + Correction Factor(dB/m)
2. Correction Factor(dB/m) = Antenna Factor(dB/m) + Cable Factor(dB) – Pre-Amplifier Factor(dB)
3. The other emission levels were very low against the limit.
4. Margin value = Emission Level – Limit value
5. " * ": Fundamental frequency.
6. " # ": The radiated frequency is out of the restricted band.

CHANNEL	TX Channel 157	DETECTOR FUNCTION	Peak (PK)
FREQUENCY RANGE	1GHz ~ 40GHz		Average (AV)

ANTENNA POLARITY & TEST DISTANCE: HORIZONTAL AT 3 M

NO.	FREQ. (MHz)	EMISSION LEVEL (dBuV/m)	LIMIT (dBuV/m)	MARGIN (dB)	ANTENNA HEIGHT (m)	TABLE ANGLE (Degree)	RAW VALUE (dBuV)	CORRECTION FACTOR (dB/m)
1	#5597.50	59.0 PK	68.2	-9.2	2.94 H	218	56.5	2.5
2	*5785.00	109.0 PK			2.94 H	218	106.3	2.7
3	*5785.00	98.1 AV			2.94 H	218	95.4	2.7
4	#5987.48	58.8 PK	68.2	-9.4	2.94 H	218	55.5	3.3
5	11570.00	61.6 PK	74.0	-12.4	1.77 H	221	48.5	13.1
6	11570.00	46.8 AV	54.0	-7.2	1.77 H	221	33.7	13.1
7	#17355.00	56.7 PK	74.0	-17.3	1.83 H	163	37.9	18.8
8	#17355.00	45.0 AV	54.0	-9.0	1.83 H	163	26.2	18.8

ANTENNA POLARITY & TEST DISTANCE: VERTICAL AT 3 M

NO.	FREQ. (MHz)	EMISSION LEVEL (dBuV/m)	LIMIT (dBuV/m)	MARGIN (dB)	ANTENNA HEIGHT (m)	TABLE ANGLE (Degree)	RAW VALUE (dBuV)	CORRECTION FACTOR (dB/m)
1	#5551.90	60.4 PK	68.2	-7.8	2.65 V	184	57.9	2.5
2	*5785.00	119.1 PK			2.65 V	184	116.4	2.7
3	*5785.00	108.6 AV			2.65 V	184	105.9	2.7
4	#5939.50	60.2 PK	68.2	-8.0	2.65 V	184	57.1	3.1
5	11570.00	63.4 PK	74.0	-10.6	1.98 V	196	50.3	13.1
6	11570.00	51.3 AV	54.0	-2.7	1.98 V	196	38.2	13.1
7	#17355.00	56.7 PK	74.0	-17.3	1.89 V	135	37.9	18.8
8	#17355.00	44.0 AV	54.0	-10.0	1.89 V	135	25.2	18.8

REMARKS:

1. Emission Level(dBuV/m) = Raw Value(dBuV) + Correction Factor(dB/m)
2. Correction Factor(dB/m) = Antenna Factor(dB/m) + Cable Factor(dB) – Pre-Amplifier Factor(dB)
3. The other emission levels were very low against the limit.
4. Margin value = Emission Level – Limit value
5. " * ": Fundamental frequency.
6. " # ": The radiated frequency is out of the restricted band.

CHANNEL	TX Channel 165	DETECTOR FUNCTION	Peak (PK)
FREQUENCY RANGE	1GHz ~ 40GHz		Average (AV)

ANTENNA POLARITY & TEST DISTANCE: HORIZONTAL AT 3 M

NO.	FREQ. (MHz)	EMISSION LEVEL (dBuV/m)	LIMIT (dBuV/m)	MARGIN (dB)	ANTENNA HEIGHT (m)	TABLE ANGLE (Degree)	RAW VALUE (dBuV)	CORRECTION FACTOR (dB/m)
1	#5581.35	58.6 PK	68.2	-9.6	2.89 H	202	56.1	2.5
2	*5825.00	106.9 PK			2.89 H	202	104.2	2.7
3	*5825.00	96.3 AV			2.89 H	202	93.6	2.7
4	#5945.20	60.1 PK	68.2	-8.1	2.89 H	202	57.0	3.1
5	11650.00	68.0 PK	74.0	-6.0	1.64 H	221	54.9	13.1
6	11650.00	53.9 AV	54.0	-0.1	1.64 H	221	40.8	13.1
7	#17475.00	56.9 PK	74.0	-17.1	1.79 H	160	37.7	19.2
8	#17475.00	45.5 AV	54.0	-8.5	1.79 H	160	26.3	19.2

ANTENNA POLARITY & TEST DISTANCE: VERTICAL AT 3 M

NO.	FREQ. (MHz)	EMISSION LEVEL (dBuV/m)	LIMIT (dBuV/m)	MARGIN (dB)	ANTENNA HEIGHT (m)	TABLE ANGLE (Degree)	RAW VALUE (dBuV)	CORRECTION FACTOR (dB/m)
1	#5591.32	59.3 PK	68.2	-8.9	2.65 V	180	56.8	2.5
2	*5825.00	117.1 PK			2.65 V	180	114.4	2.7
3	*5825.00	105.3 AV			2.65 V	180	102.6	2.7
4	#5984.15	59.3 PK	68.2	-8.9	2.65 V	180	56.0	3.3
5	11650.00	67.1 PK	74.0	-6.9	1.98 V	193	54.0	13.1
6	11650.00	52.0 AV	54.0	-2.0	1.98 V	193	38.9	13.1
7	#17475.00	56.5 PK	74.0	-17.5	1.86 V	139	37.3	19.2
8	#17475.00	43.8 AV	54.0	-10.2	1.86 V	139	24.6	19.2

REMARKS:

1. Emission Level(dBuV/m) = Raw Value(dBuV) + Correction Factor(dB/m)
2. Correction Factor(dB/m) = Antenna Factor(dB/m) + Cable Factor(dB) – Pre-Amplifier Factor(dB)
3. The other emission levels were very low against the limit.
4. Margin value = Emission Level – Limit value
5. " * ": Fundamental frequency.
6. " # ": The radiated frequency is out of the restricted band.

802.11ac (VHT40)

CHANNEL	TX Channel 38	DETECTOR FUNCTION	Peak (PK)
FREQUENCY RANGE	1GHz ~ 40GHz		Average (AV)

ANTENNA POLARITY & TEST DISTANCE: HORIZONTAL AT 3 M

NO.	FREQ. (MHz)	EMISSION LEVEL (dBuV/m)	LIMIT (dBuV/m)	MARGIN (dB)	ANTENNA HEIGHT (m)	TABLE ANGLE (Degree)	RAW VALUE (dBuV)	CORRECTION FACTOR (dB/m)
1	5150.00	63.6 PK	74.0	-10.4	2.83 H	207	62.1	1.5
2	5150.00	51.7 AV	54.0	-2.3	2.83 H	207	50.2	1.5
3	*5190.00	101.2 PK			2.83 H	207	99.5	1.7
4	*5190.00	89.9 AV			2.83 H	207	88.2	1.7
5	5350.00	54.2 PK	74.0	-19.8	2.83 H	207	52.3	1.9
6	5350.00	44.1 AV	54.0	-9.9	2.83 H	207	42.2	1.9
7	#10380.00	60.9 PK	74.0	-13.1	1.75 H	210	49.4	11.5
8	#10380.00	49.3 AV	54.0	-4.7	1.75 H	210	37.8	11.5
9	15570.00	56.8 PK	74.0	-17.2	1.84 H	167	43.7	13.1
10	15570.00	44.9 AV	54.0	-9.1	1.84 H	167	31.8	13.1

ANTENNA POLARITY & TEST DISTANCE: VERTICAL AT 3 M

NO.	FREQ. (MHz)	EMISSION LEVEL (dBuV/m)	LIMIT (dBuV/m)	MARGIN (dB)	ANTENNA HEIGHT (m)	TABLE ANGLE (Degree)	RAW VALUE (dBuV)	CORRECTION FACTOR (dB/m)
1	5150.00	65.7 PK	74.0	-8.3	2.60 V	204	64.2	1.5
2	5150.00	53.8 AV	54.0	-0.2	2.60 V	204	52.3	1.5
3	*5190.00	110.5 PK			2.60 V	204	108.8	1.7
4	*5190.00	99.2 AV			2.60 V	204	97.5	1.7
5	5350.00	56.3 PK	74.0	-17.7	2.60 V	204	54.4	1.9
6	5350.00	46.2 AV	54.0	-7.8	2.60 V	204	44.3	1.9
7	#10380.00	62.1 PK	74.0	-11.9	3.72 V	278	50.6	11.5
8	#10380.00	48.7 AV	54.0	-5.3	3.72 V	278	37.2	11.5
9	15570.00	49.3 PK	74.0	-24.7	2.12 V	360	36.2	13.1
10	15570.00	39.2 AV	54.0	-14.8	2.12 V	360	26.1	13.1

REMARKS:

- Emission Level(dBuV/m) = Raw Value(dBuV) + Correction Factor(dB/m)
- Correction Factor(dB/m) = Antenna Factor(dB/m) + Cable Factor(dB) – Pre-Amplifier Factor(dB)
- The other emission levels were very low against the limit.
- Margin value = Emission Level – Limit value
- " * ": Fundamental frequency.
- " # ": The radiated frequency is out of the restricted band.

CHANNEL	TX Channel 46	DETECTOR FUNCTION	Peak (PK)
FREQUENCY RANGE	1GHz ~ 40GHz		Average (AV)

ANTENNA POLARITY & TEST DISTANCE: HORIZONTAL AT 3 M

NO.	FREQ. (MHz)	EMISSION LEVEL (dBuV/m)	LIMIT (dBuV/m)	MARGIN (dB)	ANTENNA HEIGHT (m)	TABLE ANGLE (Degree)	RAW VALUE (dBuV)	CORRECTION FACTOR (dB/m)
1	5150.00	62.5 PK	74.0	-11.5	2.88 H	218	61.0	1.5
2	5150.00	37.4 AV	54.0	-16.6	2.88 H	218	35.9	1.5
3	*5230.00	105.6 PK			2.88 H	218	104.0	1.6
4	*5230.00	95.0 AV			2.88 H	218	93.4	1.6
5	5382.00	58.3 PK	74.0	-15.7	2.88 H	218	56.2	2.1
6	5382.00	48.7 AV	54.0	-5.3	2.88 H	218	46.6	2.1
7	#10460.00	60.9 PK	74.0	-13.1	1.79 H	220	49.0	11.9
8	#10460.00	49.2 AV	54.0	-4.8	1.79 H	220	37.3	11.9
9	15690.00	56.5 PK	74.0	-17.5	1.83 H	157	43.2	13.3
10	15690.00	44.5 AV	54.0	-9.5	1.83 H	157	31.2	13.3

ANTENNA POLARITY & TEST DISTANCE: VERTICAL AT 3 M

NO.	FREQ. (MHz)	EMISSION LEVEL (dBuV/m)	LIMIT (dBuV/m)	MARGIN (dB)	ANTENNA HEIGHT (m)	TABLE ANGLE (Degree)	RAW VALUE (dBuV)	CORRECTION FACTOR (dB/m)
1	5150.00	64.6 PK	74.0	-9.4	2.65 V	155	63.1	1.5
2	5150.00	51.0 AV	54.0	-3.0	2.65 V	155	49.5	1.5
3	*5230.00	114.9 PK			2.65 V	155	113.3	1.6
4	*5230.00	104.3 AV			2.65 V	155	102.7	1.6
5	5382.00	60.4 PK	74.0	-13.6	2.65 V	155	58.3	2.1
6	5382.00	50.8 AV	54.0	-3.2	2.65 V	155	48.7	2.1
7	#10460.00	61.8 PK	74.0	-12.2	3.78 V	274	49.9	11.9
8	#10460.00	48.6 AV	54.0	-5.4	3.78 V	274	36.7	11.9
9	15690.00	49.5 PK	74.0	-24.5	2.11 V	356	36.2	13.3
10	15690.00	39.5 AV	54.0	-14.5	2.11 V	356	26.2	13.3

REMARKS:

1. Emission Level(dBuV/m) = Raw Value(dBuV) + Correction Factor(dB/m)
2. Correction Factor(dB/m) = Antenna Factor(dB/m) + Cable Factor(dB) – Pre-Amplifier Factor(dB)
3. The other emission levels were very low against the limit.
4. Margin value = Emission Level – Limit value
5. " * ": Fundamental frequency.
6. " # ": The radiated frequency is out of the restricted band.

CHANNEL	TX Channel 151	DETECTOR FUNCTION	Peak (PK)
FREQUENCY RANGE	1GHz ~ 40GHz		Average (AV)

ANTENNA POLARITY & TEST DISTANCE: HORIZONTAL AT 3 M

NO.	FREQ. (MHz)	EMISSION LEVEL (dBuV/m)	LIMIT (dBuV/m)	MARGIN (dB)	ANTENNA HEIGHT (m)	TABLE ANGLE (Degree)	RAW VALUE (dBuV)	CORRECTION FACTOR (dB/m)
1	#5563.77	59.1 PK	68.2	-9.1	3.06 H	211	56.6	2.5
2	*5755.00	105.1 PK			3.06 H	211	102.4	2.7
3	*5755.00	94.3 AV			3.06 H	211	91.6	2.7
4	#5954.70	59.8 PK	68.2	-8.4	3.06 H	211	56.6	3.2
5	11510.00	60.5 PK	74.0	-13.5	1.84 H	229	47.1	13.4
6	11510.00	48.8 AV	54.0	-5.2	1.84 H	229	35.4	13.4
7	#17265.00	56.3 PK	74.0	-17.7	1.78 H	153	38.0	18.3
8	#17265.00	44.4 AV	54.0	-9.6	1.78 H	153	26.1	18.3

ANTENNA POLARITY & TEST DISTANCE: VERTICAL AT 3 M

NO.	FREQ. (MHz)	EMISSION LEVEL (dBuV/m)	LIMIT (dBuV/m)	MARGIN (dB)	ANTENNA HEIGHT (m)	TABLE ANGLE (Degree)	RAW VALUE (dBuV)	CORRECTION FACTOR (dB/m)
1	#5608.43	63.5 PK	68.2	-4.7	2.76 V	175	60.9	2.6
2	*5755.00	114.9 PK			2.76 V	175	112.2	2.7
3	*5755.00	103.8 AV			2.76 V	175	101.1	2.7
4	#6006.48	61.2 PK	68.2	-7.0	2.76 V	175	57.8	3.4
5	11510.00	61.5 PK	74.0	-12.5	3.76 V	273	48.1	13.4
6	11510.00	48.5 AV	54.0	-5.5	3.76 V	273	35.1	13.4
7	#17265.00	50.0 PK	74.0	-24.0	2.15 V	356	31.7	18.3
8	#17265.00	39.7 AV	54.0	-14.3	2.15 V	356	21.4	18.3

REMARKS:

1. Emission Level(dBuV/m) = Raw Value(dBuV) + Correction Factor(dB/m)
2. Correction Factor(dB/m) = Antenna Factor(dB/m) + Cable Factor(dB) – Pre-Amplifier Factor(dB)
3. The other emission levels were very low against the limit.
4. Margin value = Emission Level – Limit value
5. " * ": Fundamental frequency.
6. " # ": The radiated frequency is out of the restricted band.

CHANNEL	TX Channel 159	DETECTOR FUNCTION	Peak (PK)
FREQUENCY RANGE	1GHz ~ 40GHz		Average (AV)

ANTENNA POLARITY & TEST DISTANCE: HORIZONTAL AT 3 M

NO.	FREQ. (MHz)	EMISSION LEVEL (dBuV/m)	LIMIT (dBuV/m)	MARGIN (dB)	ANTENNA HEIGHT (m)	TABLE ANGLE (Degree)	RAW VALUE (dBuV)	CORRECTION FACTOR (dB/m)
1	#5633.12	59.2 PK	68.2	-9.0	3.00 H	205	56.6	2.6
2	*5795.00	105.1 PK			3.00 H	206	102.4	2.7
3	*5795.00	94.2 AV			3.00 H	206	91.5	2.7
4	#5967.05	59.7 PK	68.2	-8.5	3.00 H	205	56.5	3.2
5	11590.00	61.0 PK	74.0	-13.0	1.82 H	225	48.0	13.0
6	11590.00	49.3 AV	54.0	-4.7	1.82 H	225	36.3	13.0
7	#17385.00	56.2 PK	74.0	-17.8	1.82 H	158	37.2	19.0
8	#17385.00	44.4 AV	54.0	-9.6	1.82 H	158	25.4	19.0

ANTENNA POLARITY & TEST DISTANCE: VERTICAL AT 3 M

NO.	FREQ. (MHz)	EMISSION LEVEL (dBuV/m)	LIMIT (dBuV/m)	MARGIN (dB)	ANTENNA HEIGHT (m)	TABLE ANGLE (Degree)	RAW VALUE (dBuV)	CORRECTION FACTOR (dB/m)
1	#5624.10	61.8 PK	68.2	-6.4	2.71 V	176	59.2	2.6
2	*5795.00	116.8 PK			2.71 V	176	114.1	2.7
3	*5795.00	104.3 AV			2.71 V	176	101.6	2.7
4	#5944.25	62.7 PK	68.2	-5.5	2.71 V	176	59.6	3.1
5	11590.00	61.0 PK	74.0	-13.0	3.73 V	260	48.0	13.0
6	11590.00	48.2 AV	54.0	-5.8	3.73 V	260	35.2	13.0
7	#17385.00	49.6 PK	74.0	-24.4	2.18 V	360	30.6	19.0
8	#17385.00	39.2 AV	54.0	-14.8	2.18 V	360	20.2	19.0

REMARKS:

1. Emission Level(dBuV/m) = Raw Value(dBuV) + Correction Factor(dB/m)
2. Correction Factor(dB/m) = Antenna Factor(dB/m) + Cable Factor(dB) – Pre-Amplifier Factor(dB)
3. The other emission levels were very low against the limit.
4. Margin value = Emission Level – Limit value
5. " * ": Fundamental frequency.
6. " # ": The radiated frequency is out of the restricted band.

802.11ac (VHT80)

CHANNEL	TX Channel 42	DETECTOR FUNCTION	Peak (PK)
FREQUENCY RANGE	1GHz ~ 40GHz		Average (AV)

ANTENNA POLARITY & TEST DISTANCE: HORIZONTAL AT 3 M

NO.	FREQ. (MHz)	EMISSION LEVEL (dBuV/m)	LIMIT (dBuV/m)	MARGIN (dB)	ANTENNA HEIGHT (m)	TABLE ANGLE (Degree)	RAW VALUE (dBuV)	CORRECTION FACTOR (dB/m)
1	5150.00	67.4 PK	74.0	-6.6	3.03 H	209	65.9	1.5
2	5150.00	51.8 AV	54.0	-2.2	3.03 H	209	50.3	1.5
3	*5210.00	99.5 PK			3.03 H	209	97.8	1.7
4	*5210.00	90.0 AV			3.03 H	209	88.3	1.7
5	5350.00	56.5 PK	74.0	-17.5	3.03 H	209	54.6	1.9
6	5350.00	45.6 AV	54.0	-8.4	3.03 H	209	43.7	1.9
7	#10420.00	60.8 PK	74.0	-13.2	1.84 H	214	49.1	11.7
8	#10420.00	49.0 AV	54.0	-5.0	1.84 H	214	37.3	11.7
9	15630.00	56.7 PK	74.0	-17.3	1.88 H	153	43.5	13.2
10	15630.00	44.6 AV	54.0	-9.4	1.88 H	153	31.4	13.2

ANTENNA POLARITY & TEST DISTANCE: VERTICAL AT 3 M

NO.	FREQ. (MHz)	EMISSION LEVEL (dBuV/m)	LIMIT (dBuV/m)	MARGIN (dB)	ANTENNA HEIGHT (m)	TABLE ANGLE (Degree)	RAW VALUE (dBuV)	CORRECTION FACTOR (dB/m)
1	5150.00	69.5 PK	74.0	-4.5	2.75 V	153	68.0	1.5
2	5150.00	53.9 AV	54.0	-0.1	2.75 V	153	52.4	1.5
3	*5210.00	108.8 PK			2.75 V	153	107.1	1.7
4	*5210.00	99.3 AV			2.75 V	153	97.6	1.7
5	5350.00	59.3 PK	74.0	-14.7	2.75 V	153	57.4	1.9
6	5350.00	48.7 AV	54.0	-5.3	2.75 V	153	46.8	1.9
7	#10420.00	61.0 PK	74.0	-13.0	3.74 V	254	49.3	11.7
8	#10420.00	48.2 AV	54.0	-5.8	3.74 V	254	36.5	11.7
9	15630.00	49.7 PK	74.0	-24.3	2.15 V	355	36.5	13.2
10	15630.00	39.3 AV	54.0	-14.7	2.15 V	355	26.1	13.2

REMARKS:

- Emission Level(dBuV/m) = Raw Value(dBuV) + Correction Factor(dB/m)
- Correction Factor(dB/m) = Antenna Factor(dB/m) + Cable Factor(dB) – Pre-Amplifier Factor(dB)
- The other emission levels were very low against the limit.
- Margin value = Emission Level – Limit value
- " * ": Fundamental frequency.
- " # ": The radiated frequency is out of the restricted band.

CHANNEL	TX Channel 155	DETECTOR FUNCTION	Peak (PK)
FREQUENCY RANGE	1GHz ~ 40GHz		Average (AV)

ANTENNA POLARITY & TEST DISTANCE: HORIZONTAL AT 3 M

NO.	FREQ. (MHz)	EMISSION LEVEL (dBuV/m)	LIMIT (dBuV/m)	MARGIN (dB)	ANTENNA HEIGHT (m)	TABLE ANGLE (Degree)	RAW VALUE (dBuV)	CORRECTION FACTOR (dB/m)
1	#5633.12	59.0 PK	68.2	-9.2	3.00 H	206	56.4	2.6
2	*5775.00	103.5 PK			3.00 H	201	100.8	2.7
3	*5775.00	91.0 AV			3.00 H	201	88.3	2.7
4	#5942.35	61.3 PK	68.2	-6.9	3.00 H	206	58.2	3.1
5	11550.00	61.2 PK	74.0	-12.8	1.88 H	207	48.0	13.2
6	11550.00	49.3 AV	54.0	-4.7	1.88 H	207	36.1	13.2
7	#17325.00	56.9 PK	74.0	-17.1	1.84 H	164	38.3	18.6
8	#17325.00	44.9 AV	54.0	-9.1	1.84 H	164	26.3	18.6

ANTENNA POLARITY & TEST DISTANCE: VERTICAL AT 3 M

NO.	FREQ. (MHz)	EMISSION LEVEL (dBuV/m)	LIMIT (dBuV/m)	MARGIN (dB)	ANTENNA HEIGHT (m)	TABLE ANGLE (Degree)	RAW VALUE (dBuV)	CORRECTION FACTOR (dB/m)
1	#5648.80	67.3 PK	68.2	-0.9	2.54 V	179	64.7	2.6
2	*5775.00	112.8 PK			2.35 V	330	110.1	2.7
3	*5775.00	100.3 AV			2.35 V	330	97.6	2.7
4	#5921.45	70.6 PK	70.8	-0.2	2.54 V	179	67.5	3.1
5	11550.00	60.9 PK	74.0	-13.1	3.78 V	258	47.7	13.2
6	11550.00	48.1 AV	54.0	-5.9	3.78 V	258	34.9	13.2
7	#17325.00	49.6 PK	74.0	-24.4	2.18 V	348	31.0	18.6
8	#17325.00	39.2 AV	54.0	-14.8	2.18 V	348	20.6	18.6

REMARKS:

1. Emission Level(dBuV/m) = Raw Value(dBuV) + Correction Factor(dB/m)
2. Correction Factor(dB/m) = Antenna Factor(dB/m) + Cable Factor(dB) – Pre-Amplifier Factor(dB)
3. The other emission levels were very low against the limit.
4. Margin value = Emission Level – Limit value
5. " * ": Fundamental frequency.
6. " # ": The radiated frequency is out of the restricted band.

Below 1GHz Data

802.11ac (VHT20)

CHANNEL	TX Channel 157	DETECTOR FUNCTION	Quasi-Peak (QP)
FREQUENCY RANGE	9kHz ~ 1GHz		

ANTENNA POLARITY & TEST DISTANCE: HORIZONTAL AT 3 M

NO.	FREQ. (MHz)	EMISSION LEVEL (dBuV/m)	LIMIT (dBuV/m)	MARGIN (dB)	ANTENNA HEIGHT (m)	TABLE ANGLE (Degree)	RAW VALUE (dBuV)	CORRECTION FACTOR (dB/m)
1	30.99	30.8 QP	40.0	-9.2	1.50 H	213	40.8	-10.0
2	47.95	30.1 QP	40.0	-9.9	2.40 H	115	38.8	-8.7
3	250.00	41.5 QP	46.0	-4.5	1.00 H	226	51.5	-10.0
4	375.00	39.1 QP	46.0	-6.9	1.50 H	215	45.1	-6.0
5	874.99	38.2 QP	46.0	-7.8	1.00 H	226	34.8	3.4
6	899.99	34.5 QP	46.0	-11.5	1.50 H	206	30.7	3.8

ANTENNA POLARITY & TEST DISTANCE: VERTICAL AT 3 M

NO.	FREQ. (MHz)	EMISSION LEVEL (dBuV/m)	LIMIT (dBuV/m)	MARGIN (dB)	ANTENNA HEIGHT (m)	TABLE ANGLE (Degree)	RAW VALUE (dBuV)	CORRECTION FACTOR (dB/m)
1	42.95	36.3 QP	40.0	-3.7	1.00 V	137	45.1	-8.8
2	93.78	32.5 QP	43.5	-11.0	1.50 V	226	46.6	-14.1
3	250.00	33.2 QP	46.0	-12.8	2.00 V	118	43.2	-10.0
4	375.00	35.7 QP	46.0	-10.3	1.00 V	206	41.7	-6.0
5	625.00	33.5 QP	46.0	-12.5	1.50 V	281	33.5	0.0
6	899.99	37.8 QP	46.0	-8.2	1.50 V	241	34.0	3.8

REMARKS:

1. Emission Level(dBuV/m) = Raw Value(dBuV) + Correction Factor(dB/m)
2. Correction Factor(dB/m) = Antenna Factor(dB/m) + Cable Factor(dB) – Pre-Amplifier Factor(dB)
3. The other emission levels were very low against the limit.
4. Margin value = Emission Level – Limit value

4.2 Conducted Emission Measurement

4.2.1 Limits of Conducted Emission Measurement

Frequency (MHz)	Conducted Limit (dBuV)	
	Quasi-peak	Average
0.15 - 0.5	66 - 56	56 - 46
0.50 - 5.0	56	46
5.0 - 30.0	60	50

Note: 1. The lower limit shall apply at the transition frequencies.

2. The limit decreases in line with the logarithm of the frequency in the range of 0.15 to 0.50MHz.

4.2.2 Test Instruments

DESCRIPTION & MANUFACTURER	MODEL NO.	SERIAL NO.	CALIBRATED DATE	CALIBRATED UNTIL
Test Receiver R&S	ESCS 30	847124/029	Oct. 24, 2016	Oct. 23, 2017
Line-Impedance Stabilization Network (for EUT) R&S	ESH3-Z5	848773/004	Oct. 26, 2016	Oct. 25, 2017
Line-Impedance Stabilization Network (for Peripheral) R&S	ENV216	100072	June 13, 2016	June 12, 2017
RF Cable	5D-FB	COCCAB-001	Sep. 30, 2016	Sep. 29, 2017
10 dB PAD Mini-Circuits	HAT-10+	CONATT-004	June 20, 2016	June 19, 2017
Software BVADT	BVADT_Cond_ V7.3.7.4	NA	NA	NA

Note:

1. The calibration interval of the above test instruments are 12 months and the calibrations are traceable to NML/ROC and NIST/USA.
2. The test was performed in Shielded Room No. 1.
3. Tested Date: Nov. 22, 2016

4.2.3 Test Procedure

- The EUT was placed 0.4 meters from the conducting wall of the shielded room with EUT being connected to the power mains through a line impedance stabilization network (LISN). Other support units were connected to the power mains through another LISN. The two LISNs provide 50 ohm/ 50uH of coupling impedance for the measuring instrument.
- Both lines of the power mains connected to the EUT were checked for maximum conducted interference.
- The frequency range from 150kHz to 30MHz was searched. Emission levels under (Limit - 20dB) was not recorded.

NOTE: All modes of operation were investigated and the worst-case emissions are reported.

4.2.4 Deviation from Test Standard

No deviation.

4.2.5 Test Setup

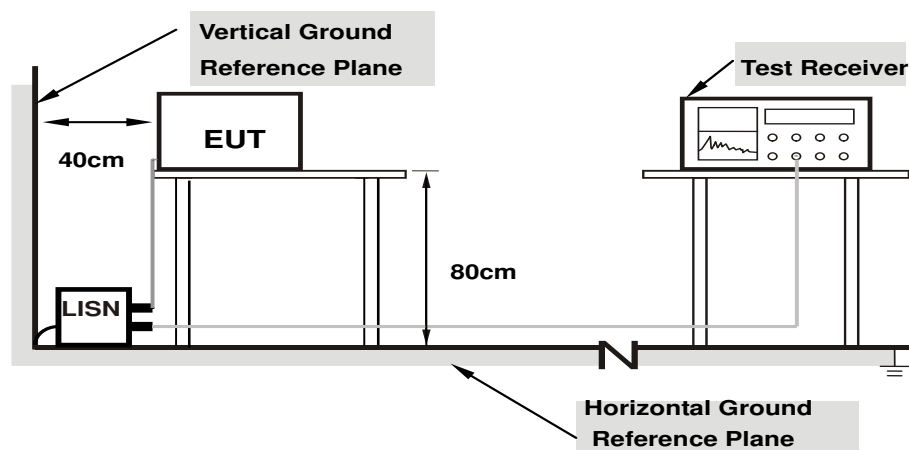

Note: 1.Support units were connected to second LISN.

For the actual test configuration, please refer to the attached file (Test Setup Photo).

4.2.6 EUT Operating Condition

Same as 4.1.6.

4.2.7 Test Results (Mode 1)

Phase	Line (L)	Detector Function	Quasi-Peak (QP) / Average (AV)
-------	----------	-------------------	--------------------------------

Phase Of Power : Line (L)										
No	Frequency (MHz)	Correction Factor (dB)	Reading Value (dBuV)		Emission Level (dBuV)		Limit (dBuV)		Margin (dB)	
			Q.P.	AV.	Q.P.	AV.	Q.P.	AV.	Q.P.	AV.
1	0.15781	10.20	37.14	25.33	47.34	35.53	65.58	55.58	-18.24	-20.05
2	0.17734	10.20	28.66	10.14	38.86	20.34	64.61	54.61	-25.75	-34.27
3	3.36719	10.30	19.00	12.31	29.30	22.61	56.00	46.00	-26.70	-23.39
4	8.65234	10.64	26.54	20.93	37.18	31.57	60.00	50.00	-22.82	-18.43
5	11.67188	10.92	26.48	21.23	37.40	32.15	60.00	50.00	-22.60	-17.85
6	15.77734	11.36	22.38	16.65	33.74	28.01	60.00	50.00	-26.26	-21.99

Remarks:

1. Q.P. and AV. are abbreviations of quasi-peak and average individually.
2. The emission levels of other frequencies were very low against the limit.
3. Margin value = Emission level – Limit value
4. Correction factor = Insertion loss + Cable loss
5. Emission Level = Correction Factor + Reading Value

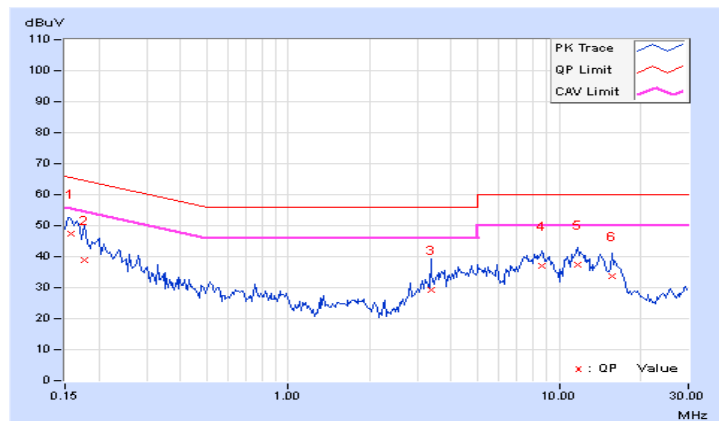

Phase	Neutral (N)	Detector Function	Quasi-Peak (QP) / Average (AV)
-------	-------------	-------------------	--------------------------------

Phase Of Power : Neutral (N)										
No	Frequency (MHz)	Correction Factor (dB)	Reading Value (dBuV)		Emission Level (dBuV)		Limit (dBuV)		Margin (dB)	
			Q.P.	AV.	Q.P.	AV.	Q.P.	AV.	Q.P.	AV.
1	0.15391	10.19	33.17	18.29	43.36	28.48	65.79	55.79	-22.43	-27.31
2	0.20078	10.17	29.35	17.15	39.52	27.32	63.58	53.58	-24.06	-26.26
3	0.48203	10.24	19.55	14.01	29.79	24.25	56.30	46.30	-26.51	-22.05
4	8.49609	10.53	26.02	20.57	36.55	31.10	60.00	50.00	-23.45	-18.90
5	11.56250	10.77	26.04	20.69	36.81	31.46	60.00	50.00	-23.19	-18.54
6	14.37500	11.03	25.57	20.16	36.60	31.19	60.00	50.00	-23.40	-18.81

Remarks:

1. Q.P. and AV. are abbreviations of quasi-peak and average individually.
2. The emission levels of other frequencies were very low against the limit.
3. Margin value = Emission level – Limit value
4. Correction factor = Insertion loss + Cable loss
5. Emission Level = Correction Factor + Reading Value

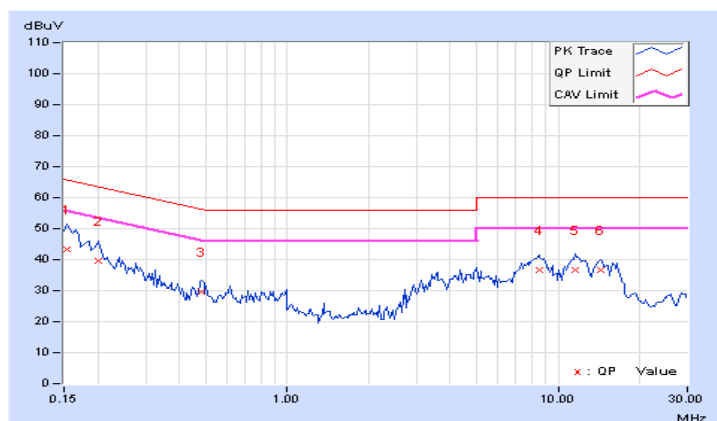

4.2.8 Test Results (Mode 2)

Phase	Line (L)	Detector Function	Quasi-Peak (QP) / Average (AV)
-------	----------	-------------------	--------------------------------

Phase Of Power : Line (L)										
No	Frequency (MHz)	Correction Factor (dB)	Reading Value (dBuV)		Emission Level (dBuV)		Limit (dBuV)		Margin (dB)	
			Q.P.	AV.	Q.P.	AV.	Q.P.	AV.	Q.P.	AV.
1	0.15000	10.20	36.05	22.40	46.25	32.60	66.00	56.00	-19.75	-23.40
2	0.16172	10.20	32.32	15.31	42.52	25.51	65.38	55.38	-22.86	-29.87
3	0.19297	10.20	30.22	14.31	40.42	24.51	63.91	53.91	-23.49	-29.40
4	0.25547	10.21	22.65	9.18	32.86	19.39	61.58	51.58	-28.72	-32.19
5	0.34141	10.23	21.83	13.35	32.06	23.58	59.17	49.17	-27.11	-25.59
6	11.28906	10.88	11.80	5.17	22.68	16.05	60.00	50.00	-37.32	-33.95

Remarks:

1. Q.P. and AV. are abbreviations of quasi-peak and average individually.
2. The emission levels of other frequencies were very low against the limit.
3. Margin value = Emission level – Limit value
4. Correction factor = Insertion loss + Cable loss
5. Emission Level = Correction Factor + Reading Value

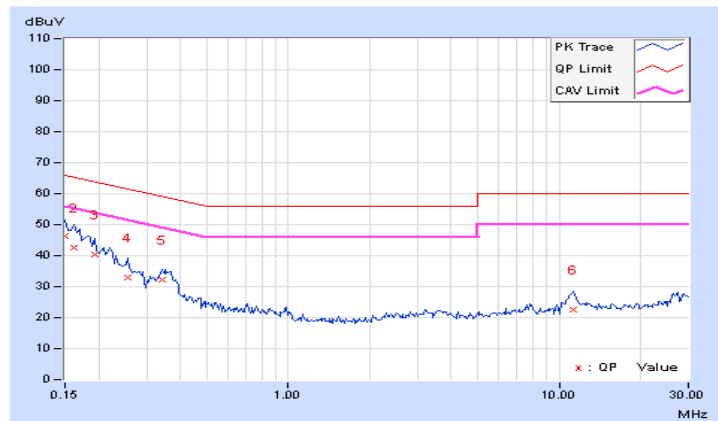

Phase	Neutral (N)	Detector Function	Quasi-Peak (QP) / Average (AV)
-------	-------------	-------------------	--------------------------------

Phase Of Power : Neutral (N)										
No	Frequency (MHz)	Correction Factor (dB)	Reading Value (dBuV)		Emission Level (dBuV)		Limit (dBuV)		Margin (dB)	
			Q.P.	AV.	Q.P.	AV.	Q.P.	AV.	Q.P.	AV.
1	0.15000	10.19	35.97	22.50	46.16	32.69	66.00	56.00	-19.84	-23.31
2	0.20078	10.17	28.89	14.12	39.06	24.29	63.58	53.58	-24.52	-29.29
3	0.34141	10.22	21.25	12.85	31.47	23.07	59.17	49.17	-27.70	-26.10
4	0.97422	10.26	5.75	0.26	16.01	10.52	56.00	46.00	-39.99	-35.48
5	10.55859	10.68	9.34	2.23	20.02	12.91	60.00	50.00	-39.98	-37.09
6	27.75781	11.40	3.15	-2.19	14.55	9.21	60.00	50.00	-45.45	-40.79

Remarks:

1. Q.P. and AV. are abbreviations of quasi-peak and average individually.
2. The emission levels of other frequencies were very low against the limit.
3. Margin value = Emission level – Limit value
4. Correction factor = Insertion loss + Cable loss
5. Emission Level = Correction Factor + Reading Value

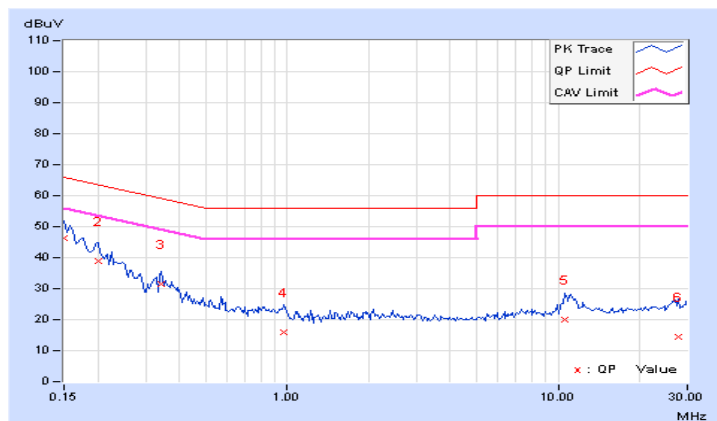

4.3 Transmit Power Measurement

4.3.1 Limits of Transmit Power Measurement

Operation Band	EUT Category		Limit
U-NII-1		Outdoor Access Point	1 Watt (30 dBm) (Max. e.i.r.p \leq 125mW(21 dBm) at any elevation angle above 30 degrees as measured from the horizon)
		Fixed point-to-point Access Point	1 Watt (30 dBm)
	√	Indoor Access Point	1 Watt (30 dBm)
		Mobile and Portable client device	250mW (24 dBm)
U-NII-2A	---		250mW (24 dBm) or 11 dBm+10 log B*
U-NII-2C	---		250mW (24 dBm) or 11 dBm+10 log B*
U-NII-3	√		1 Watt (30 dBm)

*B is the 26 dB emission bandwidth in megahertz

Per KDB 662911 Method of conducted output power measurement on IEEE 802.11 devices,

Array Gain = 0 dB (i.e., no array gain) for $N_{ANT} \leq 4$;

Array Gain = 0 dB (i.e., no array gain) for channel widths ≥ 40 MHz for any N_{ANT} ;

Array Gain = $5 \log(N_{ANT}/N_{SS})$ dB or 3 dB, whichever is less for 20-MHz channel widths with $N_{ANT} \geq 5$.

For power measurements on all other devices: Array Gain = $10 \log(N_{ANT}/N_{SS})$ dB.

4.3.2 Test Setup

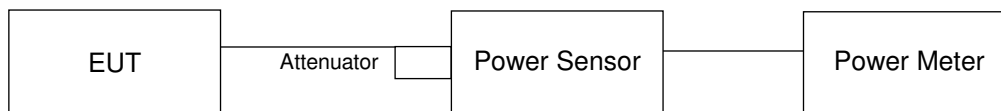

4.3.3 Test Instruments

Refer to section 4.1.2 to get information of above instrument.

4.3.4 Test Procedure

Method PM is used to perform output power measurement, trigger and gating function of wide band power meter is enabled to measure max output power of TX on burst. Duty factor is not added to measured value.

4.3.5 Deviation from Test Standard

No deviation.

4.3.6 EUT Operating Condition

The software provided by client to enable the EUT under transmission condition continuously at lowest, middle and highest channel frequencies individually.

4.3.7 Test Result

CDD Mode
802.11a

Chan.	Chan. Freq. (MHz)	Maximum Conducted Power (dBm)				Total Power (mW)	Total Power (dBm)	Limit (dBm)	Pass / Fail
		Chain 0	Chain 1	Chain 2	Chain 3				
36	5180	21.55	21.71	21.36	22.40	601.694	27.79	30	Pass
40	5200	22.04	22.08	21.15	21.36	588.482	27.70	30	Pass
48	5240	22.08	22.08	21.21	21.42	593.678	27.74	30	Pass
149	5745	23.92	23.86	23.88	23.86	977.387	29.90	30	Pass
157	5785	23.94	23.62	23.92	23.86	967.71	29.86	30	Pass
165	5825	20.78	20.15	21.17	21.28	488.382	26.89	30	Pass

802.11ac (VHT20)

Chan.	Chan. Freq. (MHz)	Maximum Conducted Power (dBm)				Total Power (mW)	Total Power (dBm)	Limit (dBm)	Pass / Fail
		Chain 0	Chain 1	Chain 2	Chain 3				
36	5180	21.46	21.80	20.96	22.22	582.778	27.66	30	Pass
40	5200	22.11	22.07	21.31	21.30	593.723	27.74	30	Pass
48	5240	21.90	22.13	21.24	21.29	585.818	27.68	30	Pass
149	5745	24.05	23.82	23.92	23.62	971.836	29.88	30	Pass
157	5785	24.16	23.79	23.98	23.64	981.188	29.92	30	Pass
165	5825	20.66	20.28	21.16	21.03	480.455	26.82	30	Pass

802.11ac (VHT40)

Chan.	Chan. Freq. (MHz)	Maximum Conducted Power (dBm)				Total Power (mW)	Total Power (dBm)	Limit (dBm)	Pass / Fail
		Chain 0	Chain 1	Chain 2	Chain 3				
38	5190	18.99	19.17	18.20	18.30	295.531	24.71	30	Pass
46	5230	24.12	24.06	23.38	23.52	955.585	29.80	30	Pass
151	5755	23.86	23.39	23.72	23.63	927.673	29.67	30	Pass
159	5795	23.79	23.45	23.68	23.74	930.579	29.69	30	Pass

802.11ac (VHT80)

Chan.	Chan. Freq. (MHz)	Maximum Conducted Power (dBm)				Total Power (mW)	Total Power (dBm)	Limit (dBm)	Pass / Fail
		Chain 0	Chain 1	Chain 2	Chain 3				
42	5210	19.00	18.41	17.94	18.17	276.621	24.42	30	Pass
155	5775	23.95	23.04	24.05	23.86	947.002	29.76	30	Pass

Beamforming Mode - NSS1

802.11ac (VHT20)

Chan.	Chan. Freq. (MHz)	Maximum Conducted Power (dBm)				Total Power (mW)	Total Power (dBm)	Limit (dBm)	Pass / Fail
		Chain 0	Chain 1	Chain 2	Chain 3				
36	5180	21.46	21.80	20.96	22.22	582.778	27.66	27.85	Pass
40	5200	22.11	22.07	21.31	21.30	593.723	27.74	27.85	Pass
48	5240	21.90	22.13	21.24	21.29	585.818	27.68	27.85	Pass
149	5745	22.97	22.62	22.85	22.58	754.849	28.78	28.79	Pass
157	5785	23.07	22.42	22.65	22.58	742.561	28.71	28.79	Pass
165	5825	20.66	20.28	21.16	21.03	480.455	26.82	28.79	Pass

Note: 1. For UNII-1: Directional gain = 8.15dBi > 6dBi , so the power limit shall be reduced to $30-(8.15-6) = 27.85\text{dBm}$.

2. For UNII-3: Directional gain = 7.21dBi > 6dBi , so the power limit shall be reduced to $30-(7.21-6) = 28.79\text{dBm}$.

802.11ac (VHT40)

Chan.	Chan. Freq. (MHz)	Maximum Conducted Power (dBm)				Total Power (mW)	Total Power (dBm)	Limit (dBm)	Pass / Fail
		Chain 0	Chain 1	Chain 2	Chain 3				
38	5190	18.99	19.17	18.20	18.30	295.531	24.71	27.85	Pass
46	5230	22.04	21.96	21.40	21.53	597.263	27.76	27.85	Pass
151	5755	22.79	22.35	22.74	22.55	729.718	28.63	28.79	Pass
159	5795	22.70	22.41	22.65	22.68	729.82	28.63	28.79	Pass

Note: 1. For UNII-1: Directional gain = 8.15dBi > 6dBi , so the power limit shall be reduced to $30-(8.15-6) = 27.85\text{dBm}$.

2. For UNII-3: Directional gain = 7.21dBi > 6dBi , so the power limit shall be reduced to $30-(7.21-6) = 28.79\text{dBm}$.

802.11ac (VHT80)

Chan.	Chan. Freq. (MHz)	Maximum Conducted Power (dBm)				Total Power (mW)	Total Power (dBm)	Limit (dBm)	Pass / Fail
		Chain 0	Chain 1	Chain 2	Chain 3				
42	5210	19.00	18.41	17.94	18.17	276.621	24.42	27.85	Pass
155	5775	22.90	22.00	23.06	22.82	747.201	28.73	28.79	Pass

Note: 1. For UNII-1: Directional gain = 8.15dBi > 6dBi , so the power limit shall be reduced to $30-(8.15-6) = 27.85\text{dBm}$.

2. For UNII-3: Directional gain = 7.21dBi > 6dBi , so the power limit shall be reduced to $30-(7.21-6) = 28.79\text{dBm}$.

Beamforming Mode – NSS2

802.11ac (VHT20)

Chan.	Chan. Freq. (MHz)	Maximum Conducted Power (dBm)				Total Power (mW)	Total Power (dBm)	Limit (dBm)	Pass / Fail
		Chain 0	Chain 1	Chain 2	Chain 3				
36	5180	21.46	21.80	20.96	22.22	582.778	27.66	30.00	Pass
40	5200	22.11	22.07	21.31	21.30	593.723	27.74	30.00	Pass
48	5240	21.90	22.13	21.24	21.29	585.818	27.68	30.00	Pass
149	5745	24.05	23.82	23.92	23.62	971.836	29.88	30.00	Pass
157	5785	24.16	23.79	23.98	23.64	981.188	29.92	30.00	Pass
165	5825	20.66	20.28	21.16	21.03	480.455	26.82	30.00	Pass

Note: 1. For UNII-1: Directional gain = 5.14dBi < 6dBi, so the power limit shall not be reduced.

2. For UNII-3: Directional gain = 4.2dBi < 6dBi, so the power limit shall not be reduced.

802.11ac (VHT40)

Chan.	Chan. Freq. (MHz)	Maximum Conducted Power (dBm)				Total Power (mW)	Total Power (dBm)	Limit (dBm)	Pass / Fail
		Chain 0	Chain 1	Chain 2	Chain 3				
38	5190	18.99	19.17	18.20	18.30	295.531	24.71	30.00	Pass
46	5230	22.04	21.96	21.40	21.53	597.263	27.76	30.00	Pass
151	5755	23.86	23.39	23.72	23.63	927.673	29.67	30.00	Pass
159	5795	23.79	23.45	23.68	23.74	930.579	29.69	30.00	Pass

Note: 1. For UNII-1: Directional gain = 5.14dBi < 6dBi, so the power limit shall not be reduced.

2. For UNII-3: Directional gain = 4.2dBi < 6dBi, so the power limit shall not be reduced.

802.11ac (VHT80)

Chan.	Chan. Freq. (MHz)	Maximum Conducted Power (dBm)				Total Power (mW)	Total Power (dBm)	Limit (dBm)	Pass / Fail
		Chain 0	Chain 1	Chain 2	Chain 3				
42	5210	19.00	18.41	17.94	18.17	276.621	24.42	30.00	Pass
155	5775	23.95	23.04	24.05	23.86	947.002	29.76	30.00	Pass

Note: 1. For UNII-1: Directional gain = 5.14dBi < 6dBi, so the power limit shall not be reduced.

2. For UNII-3: Directional gain = 4.2dBi < 6dBi, so the power limit shall not be reduced.

4.4 Occupied Bandwidth Measurement

4.4.1 Test Setup



4.4.2 Test Instruments

Refer to section 4.1.2 to get information of above instrument.

4.4.3 Test Procedure

The transmitter output was connected to the spectrum analyzer through an attenuator. The bandwidth of the fundamental frequency was measured by spectrum analyzer with resolution bandwidth in the range of 1% to 5% of the anticipated emission bandwidth, and a video bandwidth at least 3x the resolution bandwidth and set the detector to SAMPLE. The width of a frequency band such that, below the lower and above the upper frequency limits, the mean powers emitted are each equal to a specified percentage 0.5 %of the total mean power of a given emission.

4.4.4 Test Results

802.11a

Channel	Channel Frequency (MHz)	Occupied Bandwidth (MHz)			
		Chain 0	Chain 1	Chain 2	Chain 3
36	5180	17.04	17.88	18.12	18.12
40	5200	17.16	18.12	18.00	18.36
48	5240	16.92	17.04	17.16	17.28
149	5745	18.24	17.04	17.88	19.08
157	5785	17.76	18.00	18.60	19.56
165	5825	17.04	17.76	18.00	18.00

802.11ac (VHT20)

Channel	Channel Frequency (MHz)	Occupied Bandwidth (MHz)			
		Chain 0	Chain 1	Chain 2	Chain 3
36	5180	18.00	18.96	18.96	18.96
40	5200	18.12	18.96	19.08	19.56
48	5240	18.00	18.24	18.12	18.36
149	5745	18.96	18.12	18.72	20.40
157	5785	18.84	19.08	19.56	20.40
165	5825	18.00	19.08	18.84	18.72

802.11ac (VHT40)

Channel	Channel Frequency (MHz)	Occupied Bandwidth (MHz)			
		Chain 0	Chain 1	Chain 2	Chain 3
38	5190	36.72	36.72	36.72	36.72
46	5230	37.68	37.20	36.96	37.44
151	5755	37.44	36.72	37.20	38.16
159	5795	37.20	36.72	37.44	37.92

802.11ac (VHT80)

Channel	Channel Frequency (MHz)	Occupied Bandwidth (MHz)			
		Chain 0	Chain 1	Chain 2	Chain 3
42	5210	75.36	75.36	74.88	74.88
155	5775	76.32	76.32	76.32	76.80

Spectrum Plot of Worst Value

802.11a / Chain 3: CH157

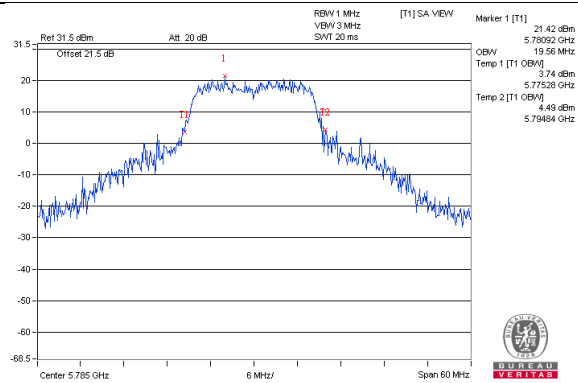

802.11ac (VHT20) / Chain 3 : CH149

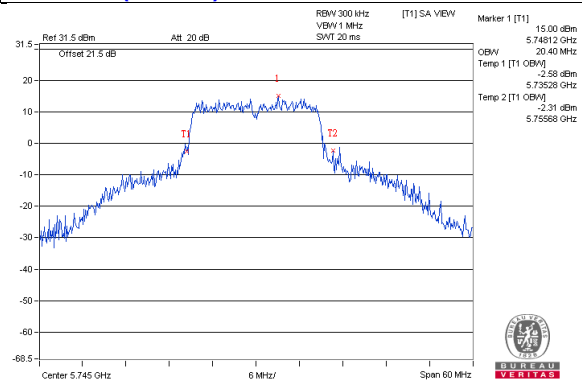

802.11ac (VHT40) / Chain 3: CH151

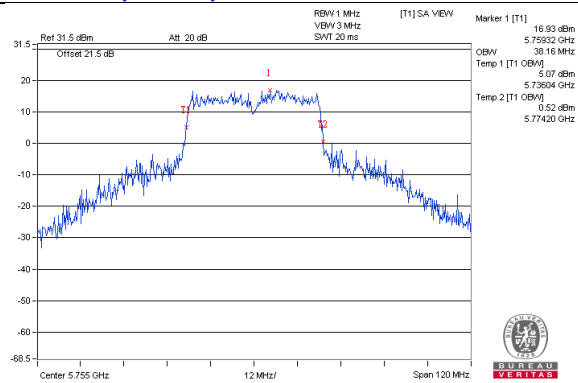

802.11ac (VHT80) / Chain 3 : CH155

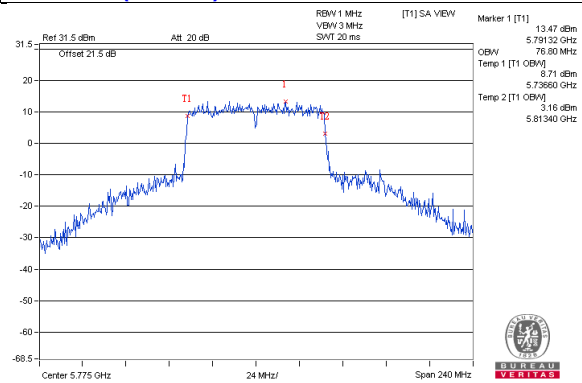

Spectrum Plot for near by DFS band (DFS is required, if 99% OCP straddle into U-NII-2A band)

802.11a / Chain 0 : CH48

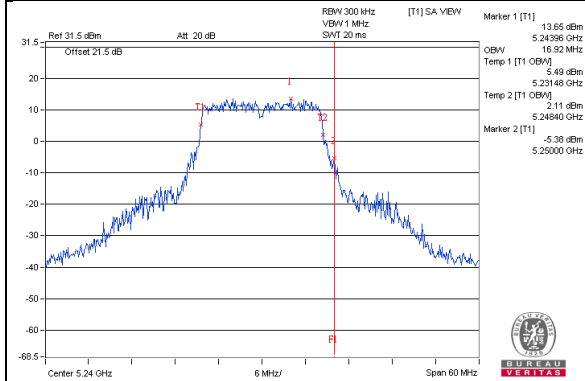

802.11a / Chain 1 : CH48

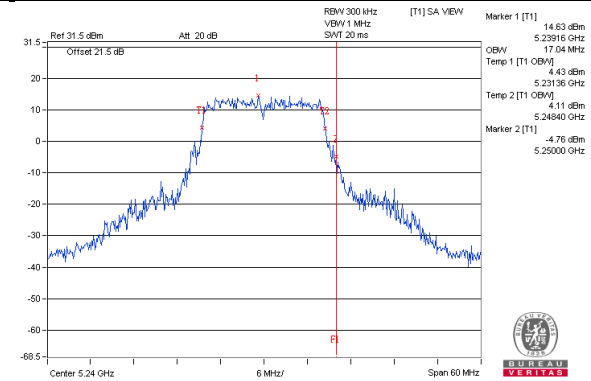

802.11a / Chain 2 : CH48

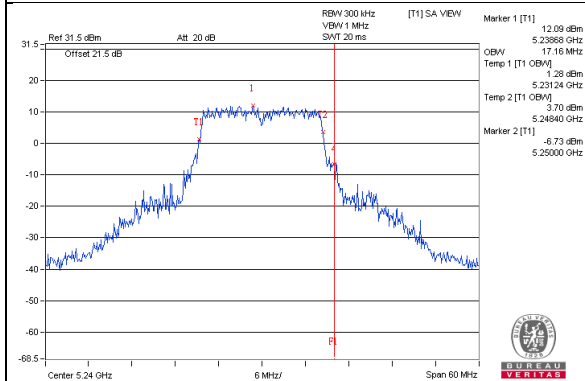

802.11a / Chain 3 : CH48

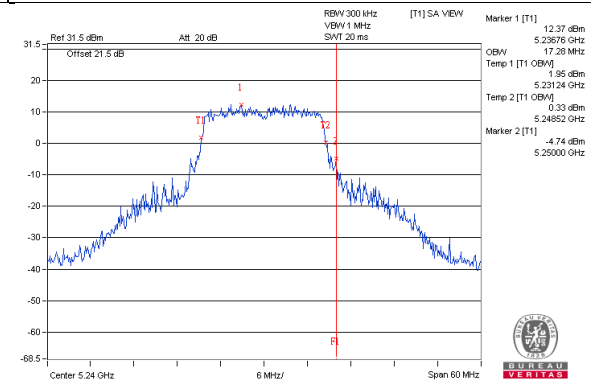

802.11ac (VHT20) / Chain 0 : CH48

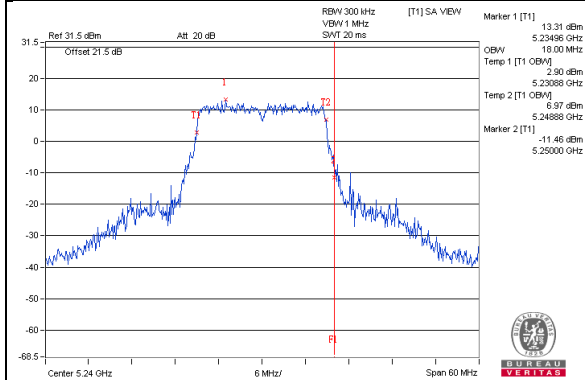

802.11ac (VHT20) / Chain 1 : CH48

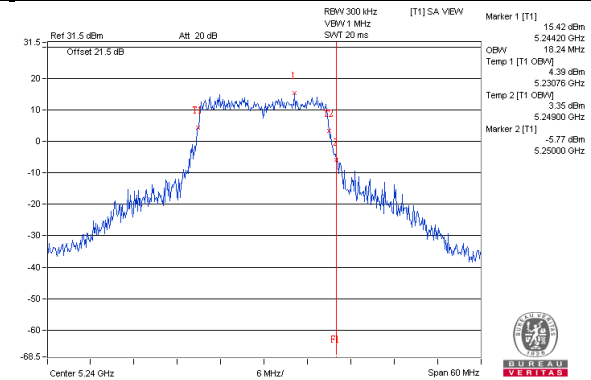

802.11ac (VHT20) / Chain 2 : CH48

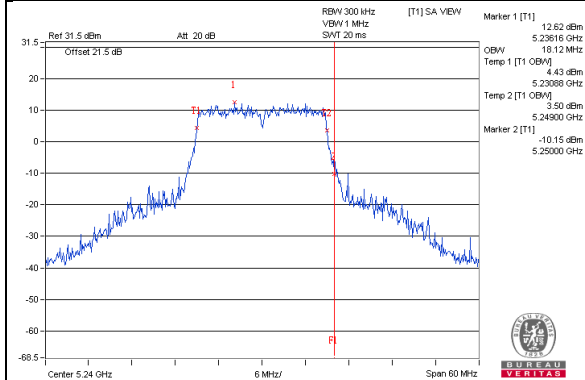

802.11ac (VHT20) / Chain 3 : CH48

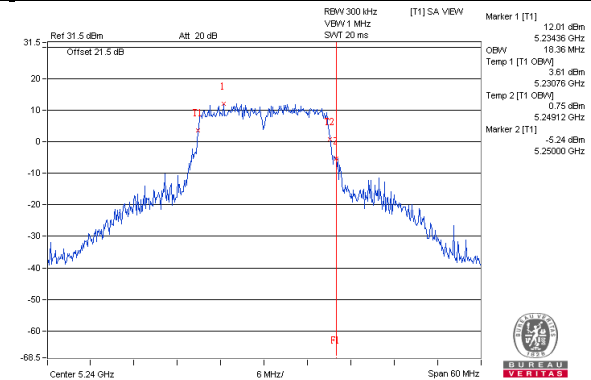

802.11ac (VHT40) / Chain 0 : CH46

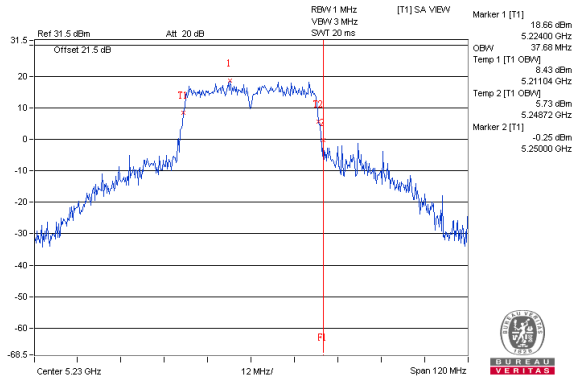

802.11ac (VHT40) / Chain 1 : CH46

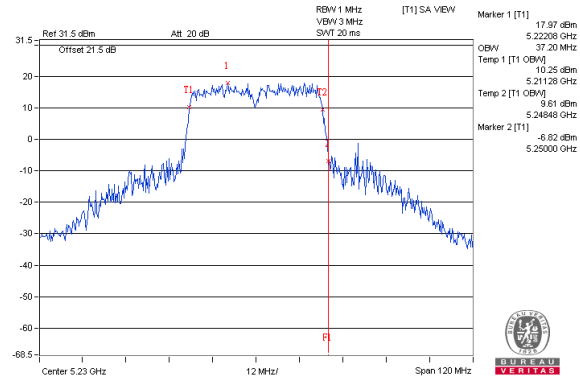

802.11ac (VHT40) / Chain 2 : CH46

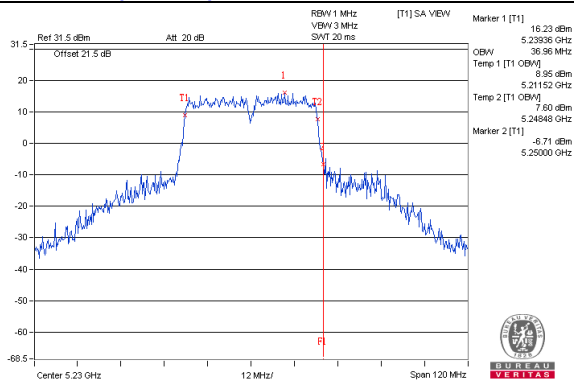

802.11ac (VHT40) / Chain 3 : CH46

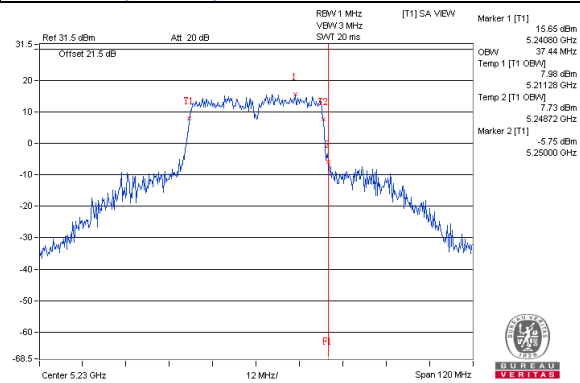

802.11ac (VHT80) / Chain 0 : CH42

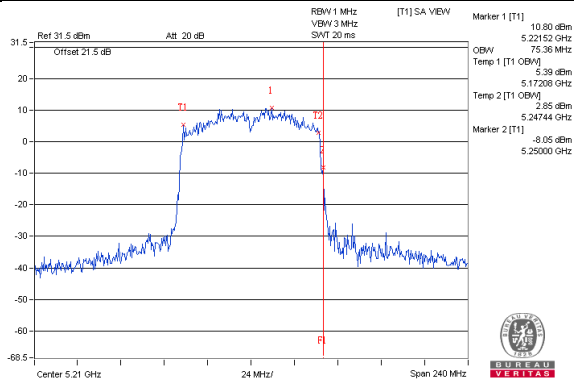

802.11ac (VHT80) / Chain 1 : CH42

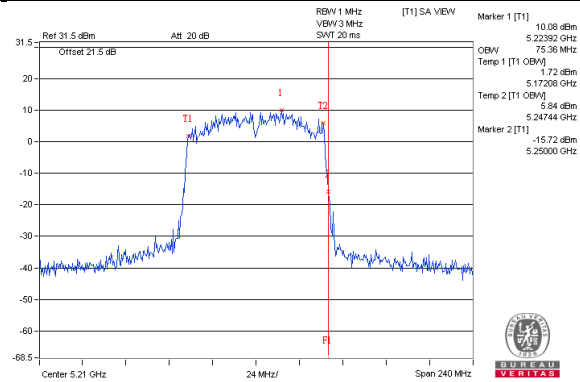

802.11ac (VHT80) / Chain 2 : CH42

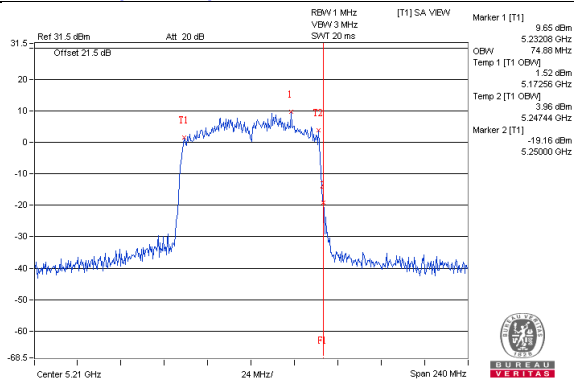

802.11ac (VHT80) / Chain 3 : CH42

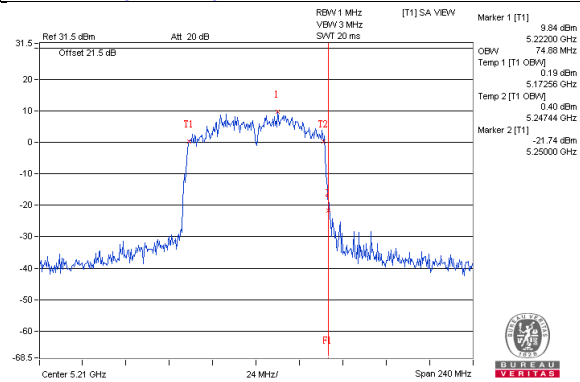

**Spectrum Plot for near by DFS band
(DFS is required, if 99% OCP straddle into U-NII-2C band)**

802.11a / Chain 0 : CH149

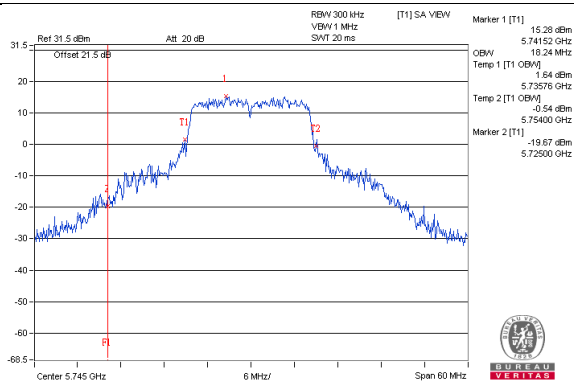

802.11a / Chain 1 : CH149

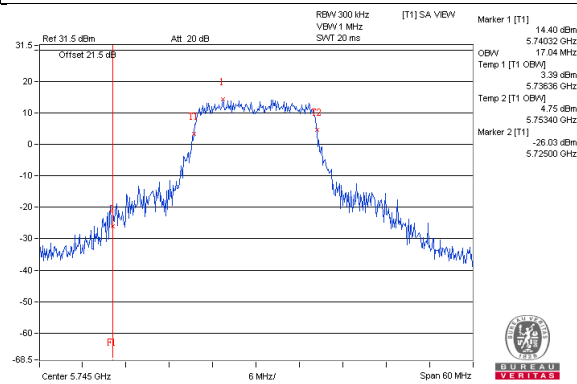

802.11a / Chain 2 : CH149

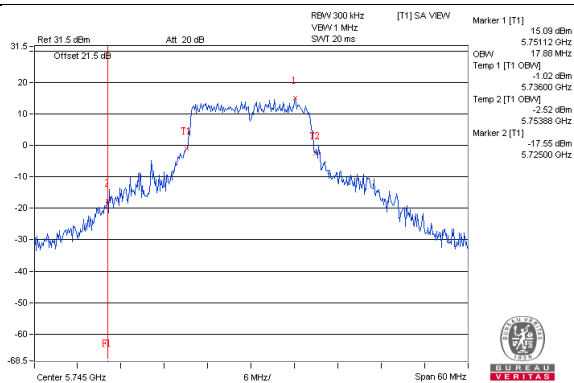

802.11a / Chain 3 : CH149

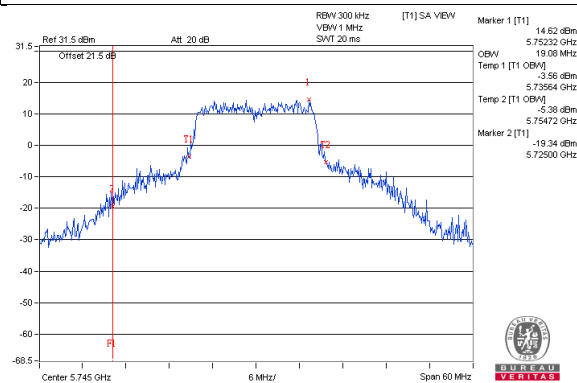

802.11ac (VHT20) / Chain 0 : CH149

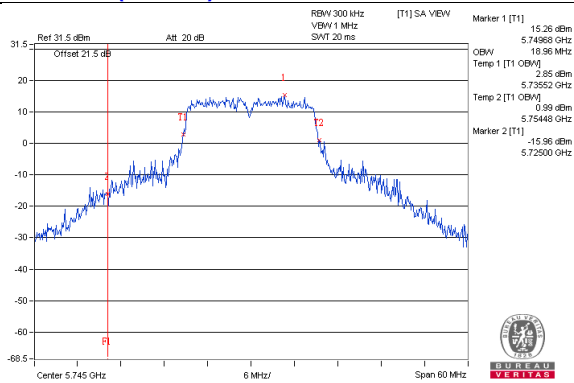

802.11ac (VHT20) / Chain 1 : CH149

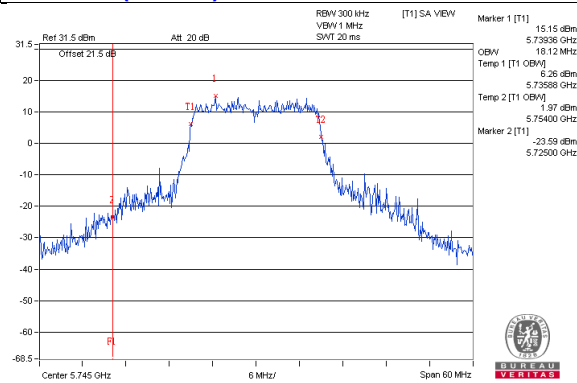

802.11ac (VHT20) / Chain 2 : CH149

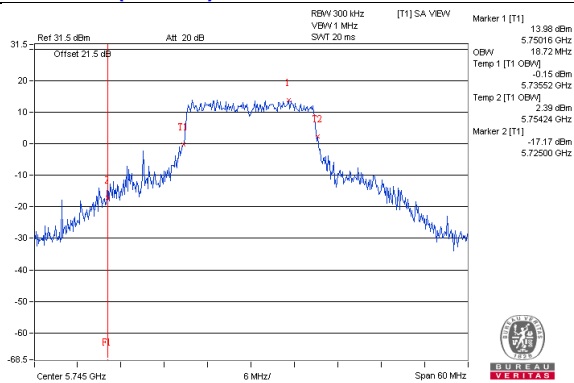

802.11ac (VHT20) / Chain 3 : CH149

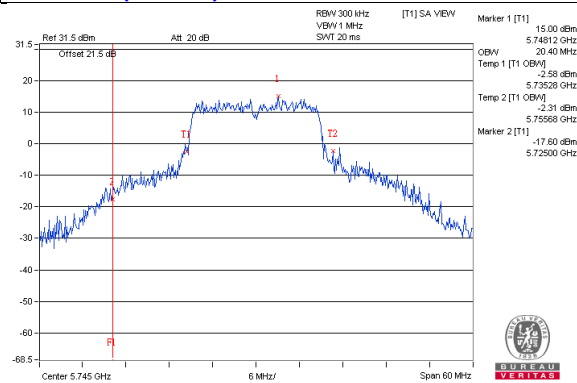

802.11ac (VHT40) / Chain 0 : CH151

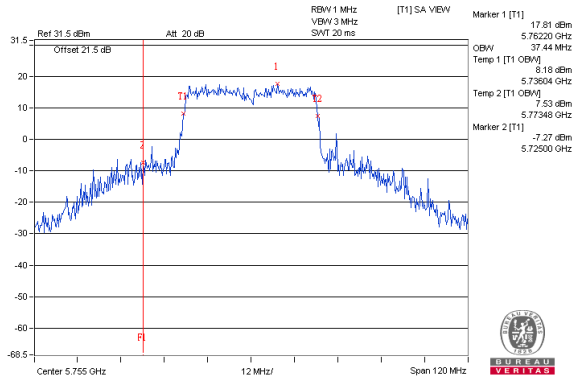

802.11ac (VHT40) / Chain 1 : CH151

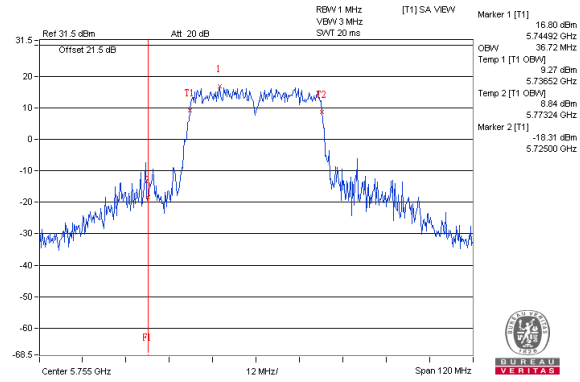

802.11ac (VHT40) / Chain 2 : CH151

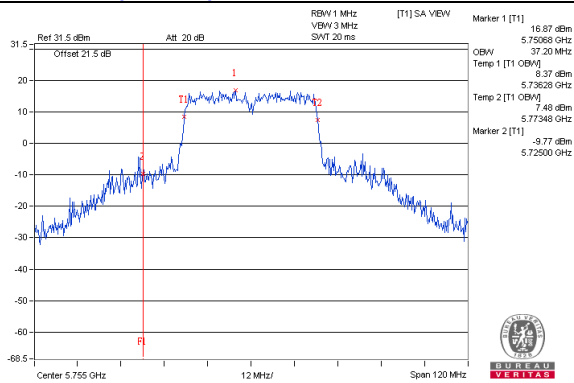

802.11ac (VHT40) / Chain 3 : CH151

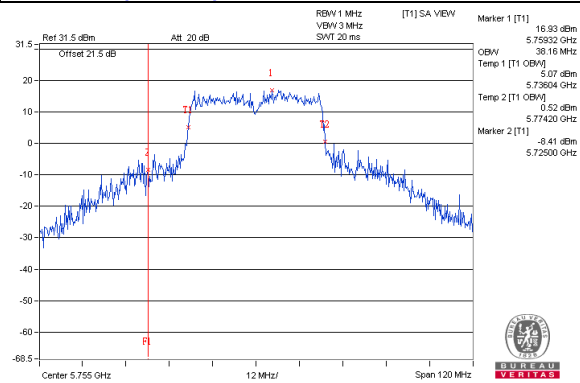

802.11ac (VHT80) / Chain 0 : CH155

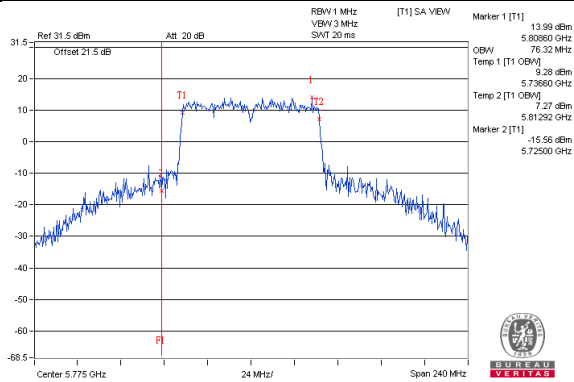

802.11ac (VHT80) / Chain 1 : CH155

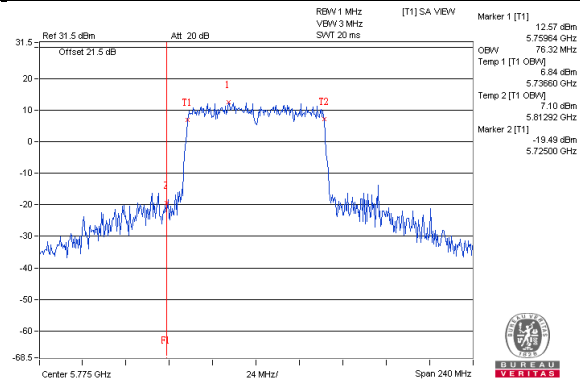

802.11ac (VHT80) / Chain 2 : CH155

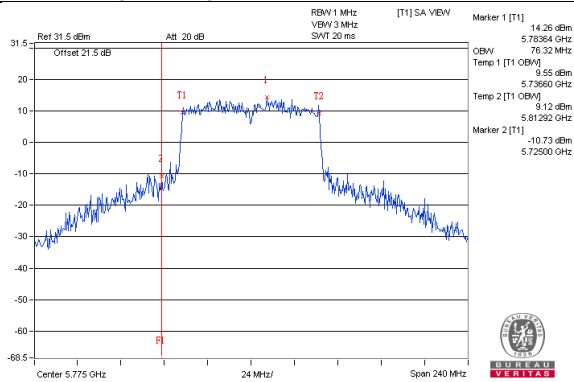

802.11ac (VHT80) / Chain 3 : CH155

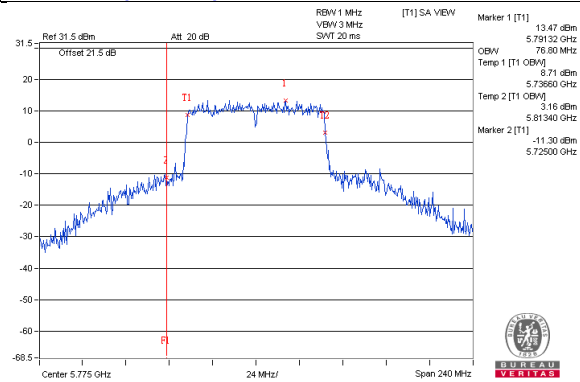

4.5 Peak Power Spectral Density Measurement

4.5.1 Limits of Peak Power Spectral Density Measurement

Operation Band	EUT Category		Limit
U-NII-1		Outdoor Access Point	17dBm/ MHz
		Fixed point-to-point Access Point	
	√	Indoor Access Point	
		Mobile and Portable client device	11dBm/ MHz
U-NII-2A	---		11dBm/ MHz
U-NII-2C	---		11dBm/ MHz
U-NII-3	√		30dBm/ 500kHz

4.5.2 Test Setup

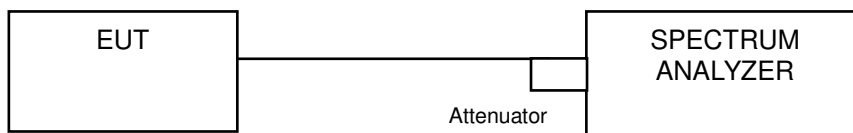

4.5.3 Test Instruments

Refer to section 4.1.2 to get information of above instrument.

4.5.4 Test Procedure

For 802.11a, 802.11ac (VHT20) & 802.11ac (VHT40):

For U-NII-1 band:

Using method SA-1

1. Set span to encompass the entire emission bandwidth (EBW) of the signal.
2. Set RBW = 1 MHz, Set VBW \geq 3 MHz, Detector = RMS
3. Sweep time = auto, trigger set to "free run".
4. Trace average at least 100 traces in power averaging mode.
5. Record the max value

For U-NII-3:

1. Set span to encompass the entire emission bandwidth (EBW) of the signal.
2. Set RBW = 300 kHz, Set VBW \geq 1 MHz, Detector = RMS
3. Use the peak marker function to determine the maximum power level in any 300 kHz band segment within the fundamental EBW.
4. Scale the observed power level to an equivalent value in 500 kHz by adjusting (reducing) the measured power by a bandwidth correction factor (BWCF) where $BWCF = 10\log(500 \text{ kHz}/300\text{kHz})$
5. Sweep time = auto, trigger set to "free run".
6. Trace average at least 100 traces in power averaging mode.
7. Record the max value

For 802.11ac (VHT80):

For U-NII-1 band:

Using method SA-2

1. Set span to encompass the entire emission bandwidth (EBW) of the signal.
2. Set RBW = 1 MHz, Set VBW \geq 3 MHz, Detector = RMS
3. Sweep time = auto, trigger set to "free run".
4. Trace average at least 100 traces in power averaging mode.
5. Record the max value and add $10 \log (1/\text{duty cycle})$

For U-NII-3:

1. Set span to encompass the entire emission bandwidth (EBW) of the signal.
2. Set RBW = 300 kHz, Set VBW \geq 1 MHz, Detector = RMS
3. Use the peak marker function to determine the maximum power level in any 300 kHz band segment within the fundamental EBW.
4. Scale the observed power level to an equivalent value in 500 kHz by adjusting (reducing) the measured power by a bandwidth correction factor (BWCF) where $BWCF = 10\log(500 \text{ kHz}/300\text{kHz})$
5. Sweep time = auto, trigger set to "free run".
6. Trace average at least 100 traces in power averaging mode.
7. Record the max value and add $10 \log (1/\text{duty cycle})$

4.5.5 Deviation from Test Standard

No deviation.

4.5.6 EUT Operating Condition

Same as Item 4.3.6.

4.5.7 Test Results

For U-NII-1:

802.11a

Chan.	Chan. Freq. (MHz)	PSD (dBm/MHz)				Total Power Density (dBm/MHz)	MAX. Limit (dBm/MHz)	Pass / Fail
		Chain 0	Chain 1	Chain 2	Chain 3			
36	5180	8.94	8.73	7.01	7.37	14.11	14.85	Pass
40	5200	7.42	7.77	7.51	7.72	13.63	14.85	Pass
48	5240	8.42	7.32	7.24	7.34	13.63	14.85	Pass

- Note:** 1. Method a) of power density measurement of KDB 662911 is using for calculating total power density. Total power density is summing entire spectra across corresponding frequency bins on the various outputs by computer.
2. Directional gain = 8.15dBi > 6dBi , so the power density limit shall be reduced to 17-(8.15-6) = 14.85dBm.

802.11ac (VHT20)

Chan.	Chan. Freq. (MHz)	PSD (dBm/MHz)				Total Power Density (dBm/MHz)	MAX. Limit (dBm/MHz)	Pass / Fail
		Chain 0	Chain 1	Chain 2	Chain 3			
36	5180	8.77	8.73	7.30	7.23	14.09	14.85	Pass
40	5200	7.98	7.77	8.00	8.29	14.03	14.85	Pass
48	5240	8.88	7.27	8.13	8.09	14.15	14.85	Pass

- Note:** 1. Method a) of power density measurement of KDB 662911 is using for calculating total power density. Total power density is summing entire spectra across corresponding frequency bins on the various outputs by computer.
2. Directional gain = 8.15dBi > 6dBi , so the power density limit shall be reduced to 17-(8.15-6) = 14.85dBm.

802.11ac (VHT40)

Chan.	Chan. Freq. (MHz)	PSD (dBm/MHz)				Total Power Density (dBm/MHz)	MAX. Limit (dBm/MHz)	Pass / Fail
		Chain 0	Chain 1	Chain 2	Chain 3			
38	5190	3.15	2.67	1.12	1.32	8.17	14.85	Pass
46	5230	8.41	8.06	6.08	5.93	13.28	14.85	Pass

- Note:** 1. Method a) of power density measurement of KDB 662911 is using for calculating total power density. Total power density is summing entire spectra across corresponding frequency bins on the various outputs by computer.
2. Directional gain = 8.15dBi > 6dBi , so the power density limit shall be reduced to 17-(8.15-6) = 14.85dBm.

802.11ac (VHT80)

Chan.	Chan. Freq. (MHz)	PSD W/O Duty Factor (dBm/MHz)				Duty Factor (dB)	Total PSD With Duty Factor (dBm/MHz)	MAX. Limit (dBm/MHz)	Pass / Fail
		Chain 0	Chain 1	Chain 2	Chain 3				
42	5210	1.32	0.23	-1.03	-0.72	0.18	6.25	14.85	Pass

- Note:**
- Method a) of power density measurement of KDB 662911 is using for calculating total power density. Total power density is summing entire spectra across corresponding frequency bins on the various outputs by computer.
 - Directional gain = 8.15dBi > 6dBi , so the power density limit shall be reduced to $17 - (8.15 - 6) = 14.85\text{dBm}$.
 - Refer to section 3.3 for duty cycle spectrum plot.

Spectrum Plot of Worst Value

802.11a / Chain 0 : CH36

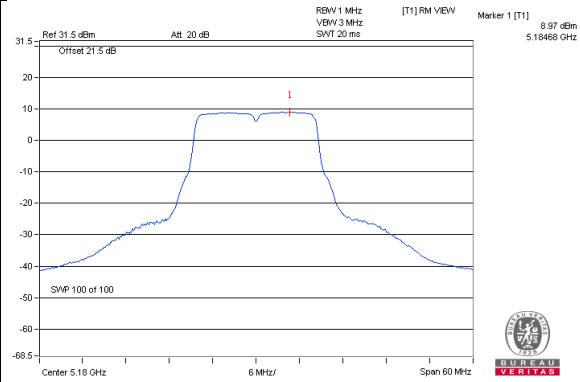

802.11ac (VHT20) / Chain 0 : CH48

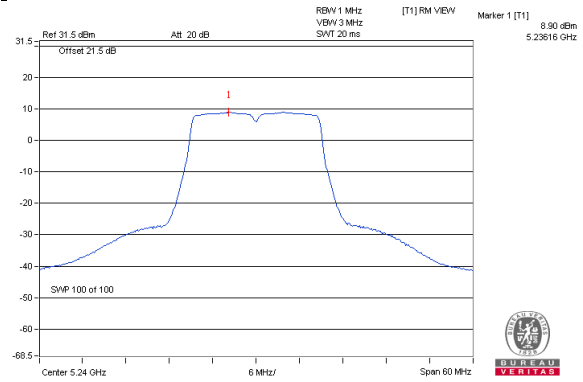

802.11ac (VHT40) / Chain 0 : CH46

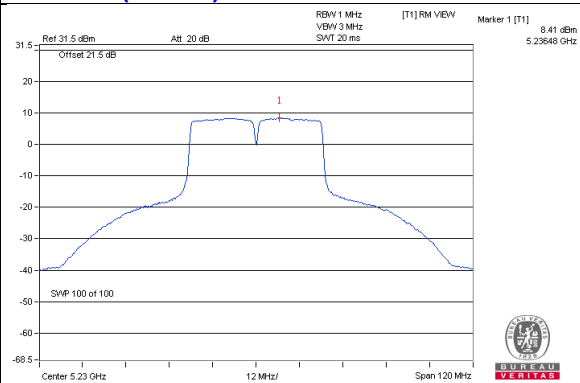

802.11ac (VHT80) / Chain 0 : CH42

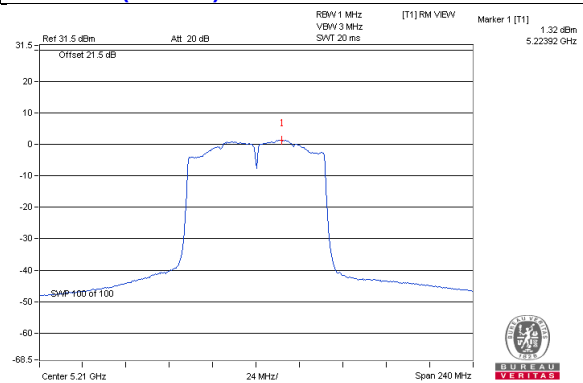

For U-NII-3:
802.11a

TX chain	Channel	Freq. (MHz)	PSD (dBm/300kHz)	PSD (dBm/500kHz)	10 log (N=4) dB	Total PSD (dBm/500kHz)	Limit (dBm/500kHz)	Pass /Fail
0	149	5745	3.24	5.46	6.02	11.48	28.79	Pass
	157	5785	3.36	5.58	6.02	11.60	28.79	Pass
	165	5825	-0.09	2.13	6.02	8.15	28.79	Pass
1	149	5745	2.33	4.55	6.02	10.57	28.79	Pass
	157	5785	2.19	4.41	6.02	10.43	28.79	Pass
	165	5825	-1.48	0.74	6.02	6.76	28.79	Pass
2	149	5745	2.52	4.74	6.02	10.76	28.79	Pass
	157	5785	2.86	5.08	6.02	11.10	28.79	Pass
	165	5825	-0.44	1.78	6.02	7.80	28.79	Pass
3	149	5745	2.52	4.74	6.02	10.76	28.79	Pass
	157	5785	2.56	4.78	6.02	10.80	28.79	Pass
	165	5825	-0.47	1.75	6.02	7.77	28.79	Pass

NOTE: 1. Directional gain = 7.21dBi > 6dBi , so the power density limit shall be reduced to $30-(7.21-6)$ =28.79dBm.

802.11ac (VHT20)

TX chain	Channel	Freq. (MHz)	PSD (dBm/300kHz)	PSD (dBm/500kHz)	10 log (N=4) dB	Total PSD (dBm/500kHz)	Limit (dBm/500kHz)	Pass /Fail
0	149	5745	3.22	5.44	6.02	11.46	28.79	Pass
	157	5785	3.12	5.34	6.02	11.36	28.79	Pass
	165	5825	-0.12	2.10	6.02	8.12	28.79	Pass
1	149	5745	1.97	4.19	6.02	10.21	28.79	Pass
	157	5785	1.69	3.91	6.02	9.93	28.79	Pass
	165	5825	0.80	3.02	6.02	9.04	28.79	Pass
2	149	5745	2.19	4.41	6.02	10.43	28.79	Pass
	157	5785	2.29	4.51	6.02	10.53	28.79	Pass
	165	5825	-0.93	1.29	6.02	7.31	28.79	Pass
3	149	5745	2.26	4.48	6.02	10.50	28.79	Pass
	157	5785	2.37	4.59	6.02	10.61	28.79	Pass
	165	5825	-0.60	1.62	6.02	7.64	28.79	Pass

NOTE: 1. Directional gain = 7.21dBi > 6dBi , so the power density limit shall be reduced to $30-(7.21-6)$ =28.79dBm.

802.11ac (VHT40)

TX chain	Channel	Freq. (MHz)	PSD (dBm/300kHz)	PSD (dBm/500kHz)	10 log (N=4) dB	Total PSD (dBm/500kHz)	Limit (dBm/500kHz)	Pass /Fail
0	151	5755	-0.62	1.60	6.02	7.62	28.79	Pass
	159	5795	-0.61	1.61	6.02	7.63	28.79	Pass
1	151	5755	-2.06	0.16	6.02	6.18	28.79	Pass
	159	5795	-2.23	-0.01	6.02	6.01	28.79	Pass
2	151	5755	-1.19	1.03	6.02	7.05	28.79	Pass
	159	5795	-0.95	1.27	6.02	7.29	28.79	Pass
3	151	5755	-1.58	0.64	6.02	6.66	28.79	Pass
	159	5795	-1.40	0.82	6.02	6.84	28.79	Pass

NOTE: 1. Directional gain = 7.21dBi > 6dBi , so the power density limit shall be reduced to $30-(7.21-6) = 28.79\text{dBm}$.

802.11ac (VHT80)

TX chain	Chan.	Chan. Freq. (MHz)	PSD W/O Duty Factor		10 log (N=4) dB	Duty Factor (dB)	Total PSD With Duty Factor (dBm/500kHz)	Limit (dBm/500kHz)	Pass /Fail
			(dBm/300kHz)	(dBm/500kHz)					
0	155	5775	-4.02	-1.80	6.02	0.18	4.40	28.79	Pass
1	155	5775	-5.49	-3.27	6.02	0.18	2.93	28.79	Pass
2	155	5775	-4.44	-2.22	6.02	0.18	3.98	28.79	Pass
3	155	5775	-4.58	-2.36	6.02	0.18	3.84	28.79	Pass

NOTE: 1. Directional gain = 7.21dBi > 6dBi , so the power density limit shall be reduced to $30-(7.21-6) = 28.79\text{dBm}$.

2. Refer to section 3.3 for duty cycle spectrum plot.

Spectrum Plot of Worst Value

802.11a – Chain 0: CH 157

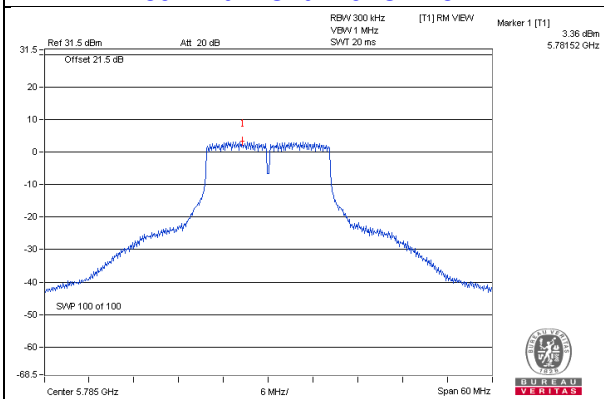

802.11ac (VHT20) – Chain 0: CH 149

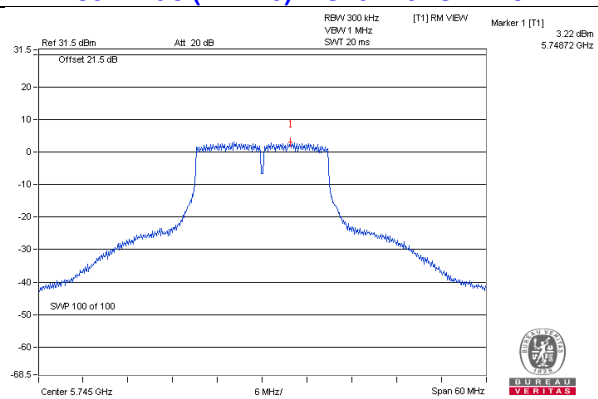

802.11ac (VHT40) – Chain 0: CH 159

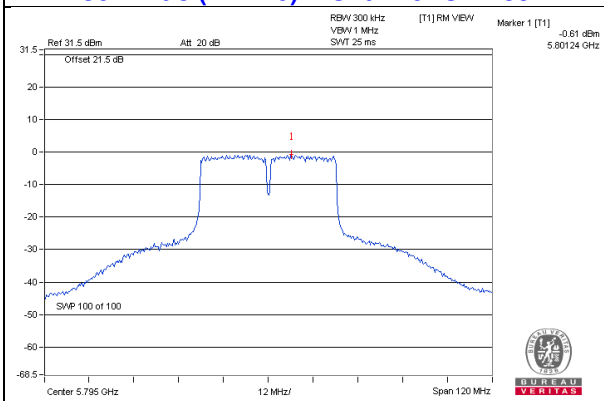

802.11ac (VHT80) – Chain 0: CH 155

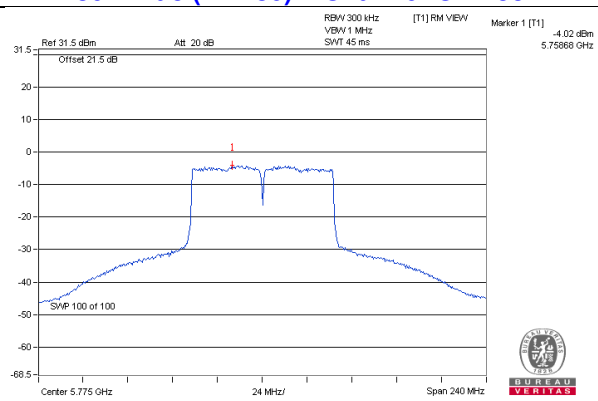

4.6 Frequency Stability Measurement

4.6.1 Limits of Frequency Stability Measurement

The frequency of the carrier signal shall be maintained within band of operation

4.6.2 Test Setup

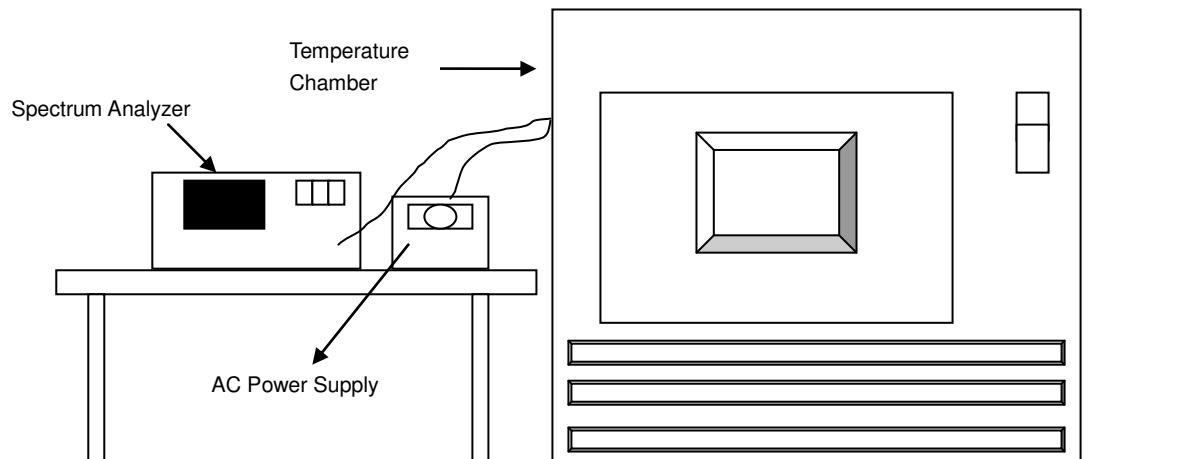

4.6.3 Test Instruments

Refer to section 4.1.2 to get information of above instrument.

4.6.4 Test Procedure

- The EUT was placed inside the environmental test chamber and powered by nominal AC voltage.
- Turn the EUT on and couple its output to a spectrum analyzer.
- Turn the EUT off and set the chamber to the highest temperature specified.
- Allow sufficient time (approximately 30 min) for the temperature of the chamber to stabilize, turn the EUT on and measure the operating frequency after 2, 5, and 10 Minutes.
- Repeat step 2 and 3 with the temperature chamber set to the lowest temperature.
- The test chamber was allowed to stabilize at +20 degree C for a minimum of 30 Minutes. The supply voltage was then adjusted on the EUT from 85% to 115% and the frequency record.

4.6.5 Deviation from Test Standard

No deviation.

4.6.6 EUT Operating Condition

Set the EUT transmit at un-modulation mode to test frequency stability.

4.6.7 Test Results

Frequency Stability Versus Temp.									
Operating Frequency: 5180 MHz									
TEMP. (°C)	Power Supply (Vac)	0 Minute		2 Minute		5 Minute		10 Minute	
		Measured Frequency (MHz)	Pass/Fail	Measured Frequency (MHz)	Pass/Fail	Measured Frequency (MHz)	Pass/Fail	Measured Frequency (MHz)	Pass/Fail
50	120	5180.0148	Pass	5180.0125	Pass	5180.011	Pass	5180.0127	Pass
40	120	5179.9858	Pass	5179.9855	Pass	5179.9843	Pass	5179.9832	Pass
30	120	5180.0187	Pass	5180.0211	Pass	5180.0207	Pass	5180.0178	Pass
20	120	5180.0091	Pass	5180.0134	Pass	5180.0121	Pass	5180.0091	Pass
10	120	5180.0055	Pass	5180.0036	Pass	5180.0038	Pass	5180.002	Pass
0	120	5180.0201	Pass	5180.0188	Pass	5180.0176	Pass	5180.021	Pass
-10	120	5179.9937	Pass	5179.9958	Pass	5179.9933	Pass	5179.9952	Pass
-20	120	5179.9801	Pass	5179.9839	Pass	5179.9826	Pass	5179.9794	Pass
-30	120	5180.0077	Pass	5180.0077	Pass	5180.0074	Pass	5180.0077	Pass

Frequency Stability Versus Voltage									
Operating Frequency: 5180 MHz									
TEMP. (°C)	Power Supply (Vac)	0 Minute		2 Minute		5 Minute		10 Minute	
		Measured Frequency (MHz)	Pass/Fail	Measured Frequency (MHz)	Pass/Fail	Measured Frequency (MHz)	Pass/Fail	Measured Frequency (MHz)	Pass/Fail
20	138	5180.009	Pass	5180.0132	Pass	5180.0122	Pass	5180.01	Pass
	120	5180.0091	Pass	5180.0134	Pass	5180.0121	Pass	5180.0091	Pass
	102	5180.0094	Pass	5180.0144	Pass	5180.0112	Pass	5180.0099	Pass

4.7 6dB Bandwidth Measurement

4.7.1 Limits of 6dB Bandwidth Measurement

The minimum of 6dB Bandwidth Measurement is 0.5MHz.

4.7.2 Test Setup

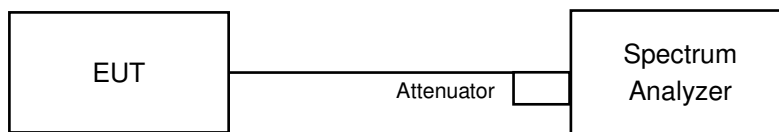

4.7.3 Test Instruments

Refer to section 4.1.2 to get information of above instrument.

4.7.4 Test Procedure

MEASUREMENT PROCEDURE REF

- Set resolution bandwidth (RBW) = 100kHz
- Set the video bandwidth (VBW) $\geq 3 \times$ RBW, Detector = Peak.
- Trace mode = max hold.
- Sweep = auto couple.
- Measure the maximum width of the emission that is constrained by the frequencies associated with the two amplitude points (upper and lower) that are attenuated by 6 dB relative to the maximum level measured in the fundamental emission

4.7.5 Deviation from Test Standard

No deviation.

4.7.6 EUT Operating Condition

The software provided by client to enable the EUT under transmission condition continuously at lowest, middle and highest channel frequencies individually.

4.7.7 Test Results

802.11a

Channel	Frequency (MHz)	6dB Bandwidth (MHz)				Minimum Limit (MHz)	Pass / Fail
		Chain 0	Chain 1	Chain 2	Chain 3		
149	5745	16.44	16.44	16.44	16.42	0.5	Pass
157	5785	16.43	16.44	16.43	16.43	0.5	Pass
165	5825	16.46	16.44	16.44	16.44	0.5	Pass

802.11ac (VHT20)

Channel	Frequency (MHz)	6dB Bandwidth (MHz)				Minimum Limit (MHz)	Pass / Fail
		Chain 0	Chain 1	Chain 2	Chain 3		
149	5745	17.71	17.71	17.69	17.67	0.5	Pass
157	5785	17.68	17.70	17.67	17.66	0.5	Pass
165	5825	17.67	17.71	17.69	17.70	0.5	Pass

802.11ac (VHT40)

Channel	Frequency (MHz)	6dB Bandwidth (MHz)				Minimum Limit (MHz)	Pass / Fail
		Chain 0	Chain 1	Chain 2	Chain 3		
151	5755	36.49	36.50	36.48	36.43	0.5	Pass
159	5795	36.48	36.50	36.49	36.46	0.5	Pass

802.11ac (VHT80)

Channel	Frequency (MHz)	6dB Bandwidth (MHz)				Minimum Limit (MHz)	Pass / Fail
		Chain 0	Chain 1	Chain 2	Chain 3		
155	5775	76.47	76.56	76.48	76.02	0.5	Pass

Spectrum Plot of Worst Value

802.11a / Chain 3 : CH149

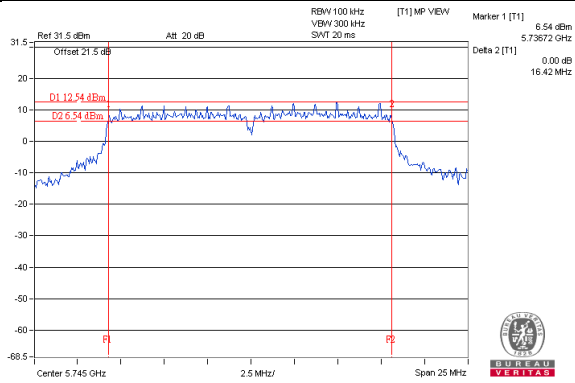

802.11ac (VHT20) / Chain 3 : CH157

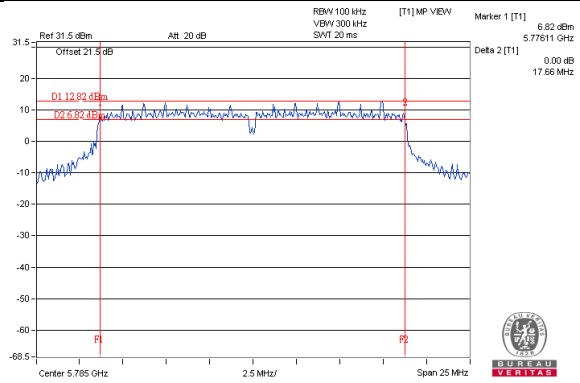

802.11ac (VHT40) / Chain 3: CH151

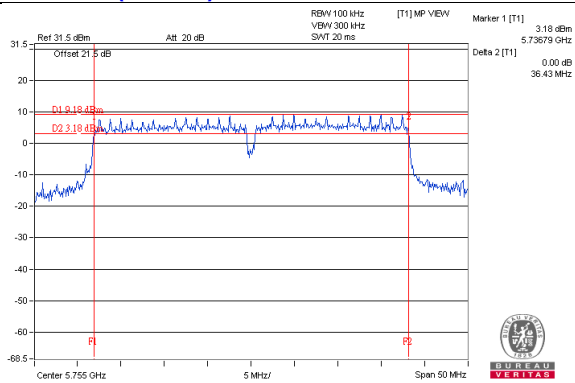

802.11ac (VHT80) / Chain 3 : CH155

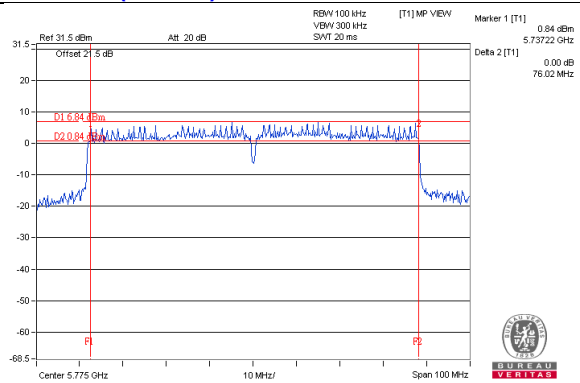

5 Pictures of Test Arrangements

Please refer to the attached file (Test Setup Photo).

Annex A- Radiated Out of Band Emission (OOBE) Measurement (For U-NII-3 band)

802.11a

CH 149 5745 MHz

Horizontal

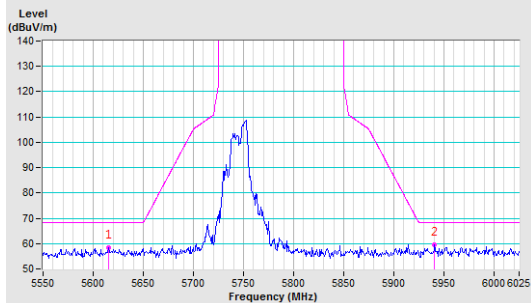

Vertical

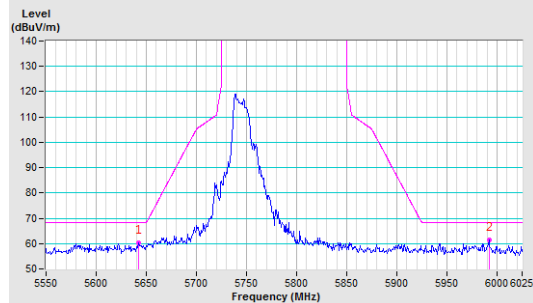

CH 157 5785 MHz

Horizontal

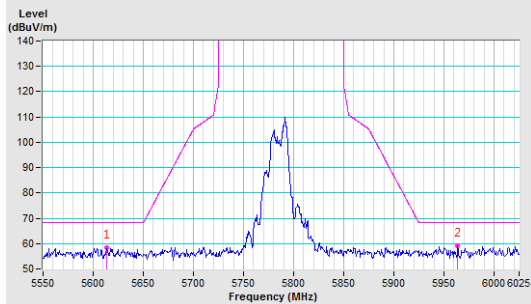

Vertical

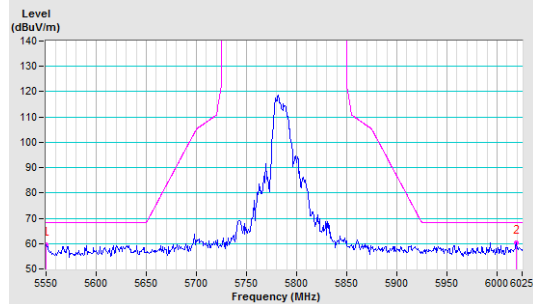

CH 165 5825 MHz

Horizontal

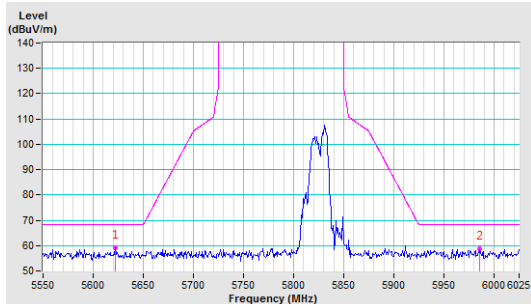

Vertical

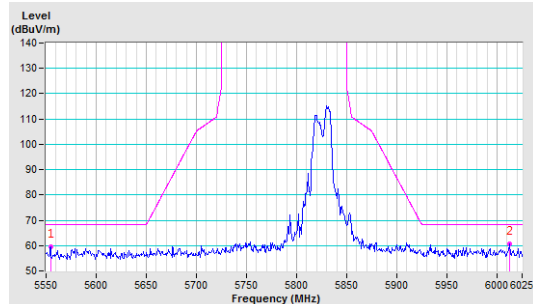

802.11ac (VHT20)

CH 149 5745 MHz

Horizontal

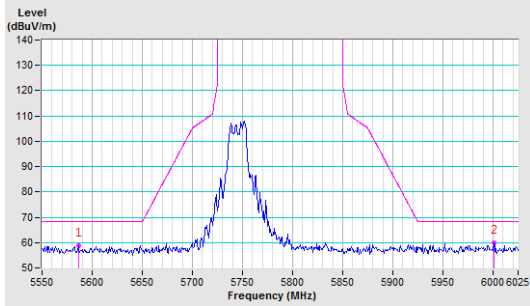

Vertical

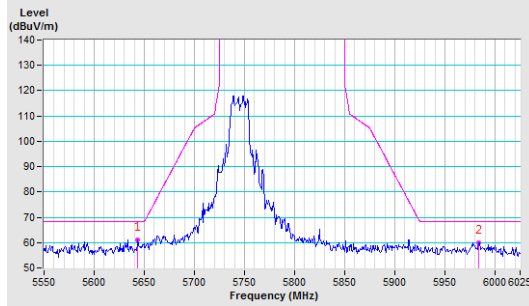

CH 157 5785 MHz

Horizontal

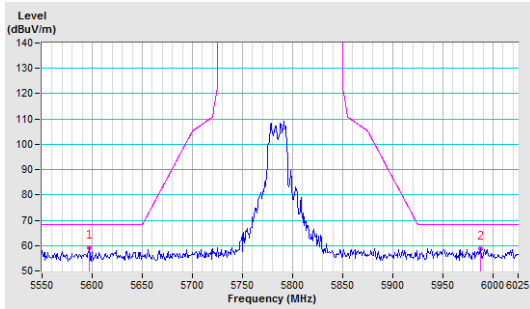

Vertical

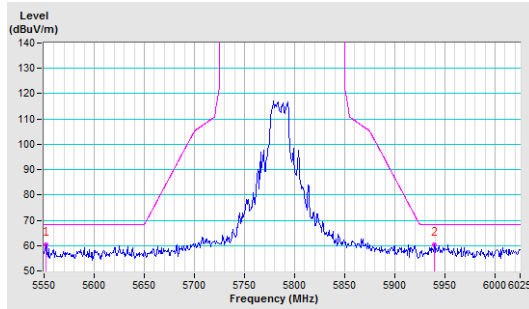

CH 165 5825 MHz

Horizontal

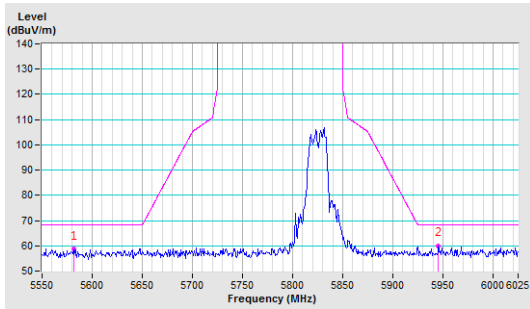

Vertical

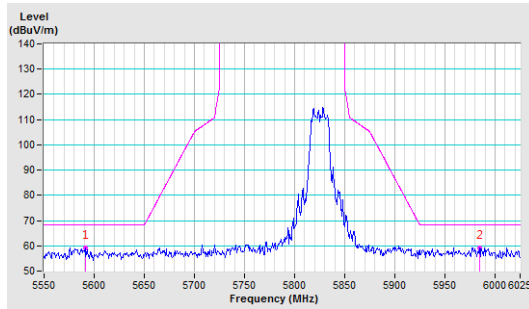

802.11ac (VHT40)

CH 151 5755 MHz

Horizontal

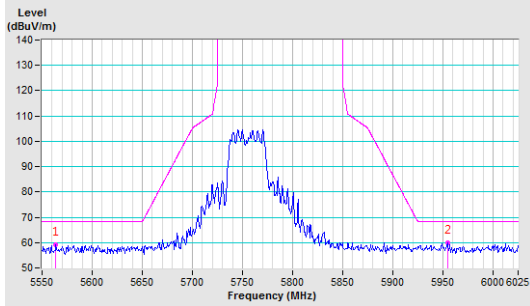

Vertical

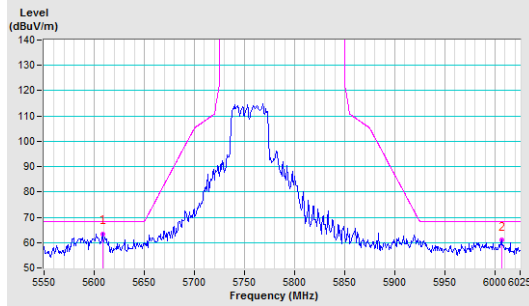

CH 159 5795 MHz

Horizontal

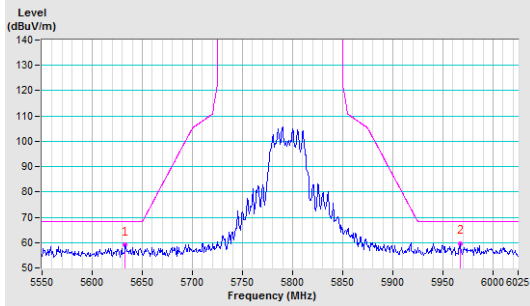

Vertical

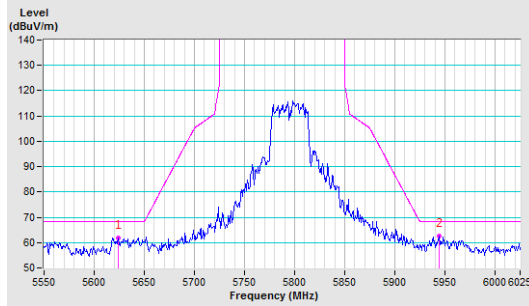

802.11ac (VHT80)

CH 155 5775 MHz

Horizontal

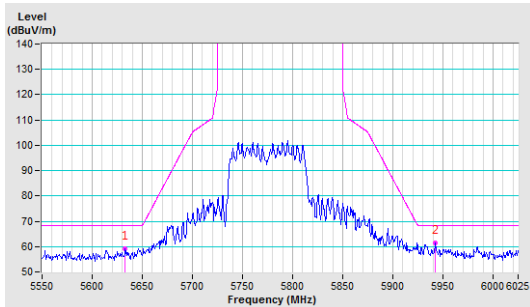

Vertical

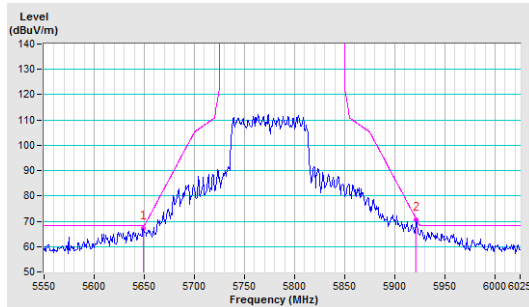

Appendix – Information on the Testing Laboratories

We, Bureau Veritas Consumer Products Services (H.K.) Ltd., Taoyuan Branch, were founded in 1988 to provide our best service in EMC, Radio, Telecom and Safety consultation. Our laboratories are accredited and approved according to ISO/IEC 17025.

If you have any comments, please feel free to contact us at the following:

Linko EMC/RF Lab

Tel: 886-2-26052180

Fax: 886-2-26051924

Hsin Chu EMC/RF/Telecom Lab

Tel: 886-3-6668565

Fax: 886-3-6668323

Hwa Ya EMC/RF/Safety Lab

Tel: 886-3-3183232

Fax: 886-3-3270892

Email: service.adt@tw.bureauveritas.com

Web Site: www.bureauveritas-adt.com

The address and road map of all our labs can be found in our web site also.

--- END ---