

FCC Test Report

Report No.: RF150925E07B

FCC ID: PY316100338

Test Model: VMC3040S

Received Date: Sep. 25, 2015

Test Date: Oct. 22 to 23, 2015 & Mar. 03 to 25, 2016

Issued Date: Apr. 07, 2016

Applicant: NETGEAR, Inc.

Address: 350 East Plumeria Drive San Jose, CA 95134

Issued By: Bureau Veritas Consumer Products Services (H.K.) Ltd., Taoyuan Branch
Hsin Chu Laboratory

Lab Address: E-2, No.1, Li Hsin 1st Road, Hsinchu Science Park, Hsinchu City 300,
Taiwan R.O.C.

Test Location (1): E-2, No.1, Li Hsin 1st Road, Hsinchu Science Park, Hsinchu City 300,
Taiwan R.O.C.

Test Location (2): No. 49, Ln. 206, Wende Rd., Shangshan Tsuen, Chiung Lin Hsiang, Hsin
Chu Hsien 307, Taiwan R.O.C.



This report is for your exclusive use. Any copying or replication of this report to or for any other person or entity, or use of our name or trademark, is permitted only with our prior written permission. This report sets forth our findings solely with respect to the test samples identified herein. The results set forth in this report are not indicative or representative of the quality or characteristics of the lot from which a test sample was taken or any similar or identical product specifically and expressly noted. Our report includes all of the tests requested by you and the results thereof based upon the information that you provided to us. You have 60 days from date of issuance of this report to notify us of any material error or omission caused by our negligence, provided, however, that such notice shall be in writing and shall specifically address the issue you wish to raise. A failure to raise such issue within the prescribed time shall constitute your unqualified acceptance of the completeness of this report, the tests conducted and the correctness of the report contents. Unless specific mention, the uncertainty of measurement has been explicitly taken into account to declare the compliance or non-compliance to the specification. The report must not be used by the client to claim product certification, approval, or endorsement by TAF or any government agencies.



Table of Contents

Release Control Record	4
1 Certificate of Conformity	5
2 Summary of Test Results	6
2.1 Measurement Uncertainty.....	6
2.2 Modification Record.....	6
3 General Information	7
3.1 General Description of EUT.....	7
3.2 Description of Test Modes.....	10
3.2.1 Test Mode Applicability and Tested Channel Detail.....	11
3.3 Duty Cycle of Test Signal.....	13
3.4 Description of Support Units.....	14
3.4.1 Configuration of System under Test.....	14
3.5 General Description of Applied Standards.....	17
4 Test Types and Results	18
4.1 Radiated Emission and Bandedge Measurement.....	18
4.1.1 Limits of Radiated Emission and Bandedge Measurement.....	18
4.1.2 Test Instruments.....	19
4.1.3 Test Procedures.....	21
4.1.4 Deviation from Test Standard.....	21
4.1.5 Test Setup.....	22
4.1.6 EUT Operating Conditions.....	22
4.1.7 Test Results.....	23
4.2 Conducted Emission Measurement.....	33
4.2.1 Limits of Conducted Emission Measurement.....	33
4.2.2 Test Instruments.....	33
4.2.3 Test Procedures.....	34
4.2.4 Deviation from Test Standard.....	34
4.2.5 Test Setup.....	34
4.2.6 EUT Operating Conditions.....	34
4.2.7 Test Results (Mode 1).....	35
4.2.8 Test Results (Mode 2).....	37
4.2.9 Test Results (Mode 3).....	39
4.3 6dB Bandwidth Measurement.....	41
4.3.1 Limits of 6dB Bandwidth Measurement.....	41
4.3.2 Test Setup.....	41
4.3.3 Test Instruments.....	41
4.3.4 Test Procedure.....	41
4.3.5 Deviation from Test Standard.....	41
4.3.6 EUT Operating Conditions.....	41
4.3.7 Test Result.....	42
4.4 Conducted Output Power Measurement.....	43
4.4.1 Limits of Conducted Output Power Measurement.....	43
4.4.2 Test Setup.....	43
4.4.3 Test Instruments.....	43
4.4.4 Test Procedures.....	43
4.4.5 Deviation from Test Standard.....	43
4.4.6 EUT Operating Conditions.....	43
4.4.7 Test Results.....	44
4.5 Power Spectral Density Measurement.....	45
4.5.1 Limits of Power Spectral Density Measurement.....	45
4.5.2 Test Setup.....	45
4.5.3 Test Instruments.....	45
4.5.4 Test Procedure.....	45



4.5.5	Deviation from Test Standard	45
4.5.6	EUT Operating Condition	45
4.5.7	Test Results	46
4.6	Conducted Out of Band Emission Measurement.....	48
4.6.1	Limits of Conducted Out of Band Emission Measurement	48
4.6.2	Test Setup.....	48
4.6.3	Test Instruments	48
4.6.4	Test Procedure	48
4.6.5	Deviation from Test Standard	48
4.6.6	EUT Operating Condition	48
4.6.7	Test Results	48
5	Pictures of Test Arrangements.....	55
	Appendix – Information on the Testing Laboratories	56



A D T

Release Control Record

Issue No.	Description	Date Issued
RF150925E07B	Original release.	Apr. 07, 2016



1 Certificate of Conformity

Product: Arlo Q Plus
Brand: NETGEAR
Test Model: VMC3040S
Sample Status: ENGINEERING SAMPLE
Applicant: NETGEAR, Inc.
Test Date: Oct. 22 to 23, 2015 & Mar. 03 to 25, 2016
Standards: 47 CFR FCC Part 15, Subpart C (Section 15.247)
ANSI C63.10: 2013

The above equipment has been tested by **Bureau Veritas Consumer Products Services (H.K.) Ltd., Taoyuan Branch**, and found compliance with the requirement of the above standards. The test record, data evaluation & Equipment Under Test (EUT) configurations represented herein are true and accurate accounts of the measurements of the sample's EMC characteristics under the conditions specified in this report.

Prepared by : *midoli = P* , **Date:** Apr. 07, 2016
Midoli Peng / Specialist

Approved by : *[Signature]* , **Date:** Apr. 07, 2016
May Chen / Manager

2 Summary of Test Results

47 CFR FCC Part 15, Subpart C (SECTION 15.247)			
FCC Clause	Test Item	Result	Remarks
15.207	AC Power Conducted Emission	PASS	Meet the requirement of limit. Minimum passing margin is -3.12dB at 16.23047MHz.
15.205 / 15.209 / 15.247(d)	Radiated Emissions and Band Edge Measurement	PASS	Meet the requirement of limit. Minimum passing margin is -0.1dB at 2390.00MHz.
15.247(d)	Antenna Port Emission	PASS	Meet the requirement of limit.
15.247(a)(2)	6dB bandwidth	PASS	Meet the requirement of limit.
15.247(b)	Conducted power	PASS	Meet the requirement of limit.
15.247(e)	Power Spectral Density	PASS	Meet the requirement of limit.
15.203	Antenna Requirement	PASS	No antenna connector is used.

NOTE: 1. The EUT was operating in 2.4 ~ 2.4835GHz, 5.15~5.35GHz, 5.47~5.7GHz and 5.725~5.850GHz frequencies band. This report was recorded the RF parameters including 2.4 ~ 2.4835GHz. For the 5.15~5.35GHz, 5.47~5.7GHz and 5.725~5.850GHz RF parameters was recorded in another test report.

2.1 Measurement Uncertainty

Where relevant, the following measurement uncertainty levels have been estimated for tests performed on the EUT as specified in CISPR 16-4-2:

Measurement	Frequency	Expanded Uncertainty (k=2) (±)
Conducted Emissions at mains ports	150kHz ~ 30MHz	2.86 dB
Radiated Emissions up to 1 GHz	30MHz ~ 1000MHz	5.19 dB
Radiated Emissions above 1 GHz	1GHz ~ 6GHz	3.43 dB
	6GHz ~ 18GHz	3.49 dB
	18GHz ~ 40GHz	4.11 dB

2.2 Modification Record

There were no modifications required for compliance.

3 General Information

3.1 General Description of EUT

Product	Arlo Q Plus
Brand	NETGEAR
Test Model	VMC3040S
Status of EUT	ENGINEERING SAMPLE
Power Supply Rating	DC 5V from Micro USB
Modulation Type	CCK, DQPSK, DBPSK for DSSS 64QAM, 16QAM, QPSK, BPSK for OFDM
Modulation Technology	DSSS, OFDM
Transfer Rate	802.11b: up to 11Mbps 802.11a/g: up to 54Mbps 802.11n : up to 300Mbps
Operating Frequency	For 15.407 5.18 ~ 5.24GHz, 5.26 ~ 5.32GHz, 5.50 ~ 5.70GHz, 5.745 ~ 5.825GHz
	For 15.247 2.412 ~ 2.462GHz
Number of Channel	For 15.407 24 for 802.11a, 802.11n (HT20) 11 for 802.11n (HT40)
	For 15.247 11 for 802.11b/g, 802.11n (HT20)
Output Power	For 15.407 802.11a: 185.904mW 802.11n (HT20): 172.398mW 802.11n (HT40): 200.775mW
	For 15.247 802.11b: 277.308mW 802.11g: 332.644mW 802.11n (HT20): 562.159mW
Antenna Type	Refer to Note
Antenna Connector	Refer to Note
Accessory Device	USB adapter x 1 POE adapter x1
Data Cable Supplied	Mini USB Cable (Shielded, 3m) x 1 POE adapter cable(Unshielded, 0.1m) x 1

Note:

- 2.4GHz and 5GHz technology can not transmit at same time.
- The antennas provided to the EUT, please refer to the following table:

Antenna No.	Transmitter Circuit	Brand	Model	Antenna Gain (dBi) including cable loss	Antenna Type	Connector Type	Frequency range (GHz to GHz)
1	Chain (0)	Netgear	NA	0.91	PIFA	NA	2.4~2.4835
				1.83			5.15~5.25
				1.91			5.25~5.35
				1.29			5.47~5.725
				2.12			5.725~5.85
2	Chain (1)	Netgear	NA	1.01	Monopole	NA	2.4~2.4835
				1.12			5.15~5.25
				1.91			5.25~5.35
				2.18			5.47~5.725
				2.27			5.725~5.85

- The EUT power needs to be supplied from USB adapters or POE adapter, the information is as below table:

USB adapter				
No	Brand	Model No.	P/N	Spec.
1	NETGEAR	ADS-12DA-05 05010EPCU	332-10813-01	Input: 100-240V, 50/60Hz, 0.3A Output: 5V, 2A
2	NETGEAR	AD2037320	332-10809-01	
POE adapter				
No	Brand	Part number	Spec.	
1	NETGEAR	107-11054-01	Rating 36-57V 350mA	

Note

- From the above adapters, adapter 1 was selected as representative adapter for the test and its data was recorded in this report.

- The EUT incorporates a MIMO function.

2.4GHz Band			
MODULATION MODE	DATA RATE (MCS)	TX & RX CONFIGURATION	
802.11b	1 ~ 11Mbps	2TX	2RX
802.11g	6 ~ 54Mbps	2TX	2RX
802.11n (HT20)	MCS 0~7	2TX	2RX
	MCS 8~15	2TX	2RX
5GHz Band			
MODULATION MODE	DATA RATE (MCS)	TX & RX CONFIGURATION	
802.11a	6 ~ 54Mbps	2TX	2RX
802.11n (HT20)	MCS 0~7	2TX	2RX
	MCS 8~15	2TX	2RX
802.11n (HT40)	MCS 0~7	2TX	2RX
	MCS 8~15	2TX	2RX

5. For radiated, the EUT was pre-tested under the following modes:

Test Mode	Description
Mode A	Power from USB adapter
Mode B	Power from POE adapter (LAN port)
Mode C	Power from POE adapter (USB interface)

From the above modes, the worst cases were found in Mode C (below 1GHz) & Mode A (above 1GHz). Therefore only the test data of the modes were recorded in this report.

6. The above EUT information is declared by manufacturer and for more detailed features description, please refer to the manufacturer's specifications or user's manual.

3.2 Description of Test Modes

11 channels are provided for 802.11b, 802.11g and 802.11n (HT20):

Channel	Frequency	Channel	Frequency
1	2412MHz	7	2442MHz
2	2417MHz	8	2447MHz
3	2422MHz	9	2452MHz
4	2427MHz	10	2457MHz
5	2432MHz	11	2462MHz
6	2437MHz		

3.2.1 Test Mode Applicability and Tested Channel Detail

EUT CONFIGURE MODE	APPLICABLE TO				DESCRIPTION
	RE \geq 1G	RE $<$ 1G	PLC	APCM	
1	√	-	√	√	Power from USB adapter
2	-	-	√	-	Power from POE adapter (LAN port)
3	-	√	√	-	Power from POE adapter (USB interface)

Where RE \geq 1G: Radiated Emission above 1GHz & Bandedge Measurement

RE $<$ 1G: Radiated Emission below 1GHz

PLC: Power Line Conducted Emission

APCM: Antenna Port Conducted Measurement

NOTE : 1.The EUT had been pre-tested on the positioned of each 3 axis. The worst case was found when positioned on Y-plane (for below 1GHz) and Z-plane (for above 1GHz)

2."-"means no effect.

Radiated Emission Test (Above 1GHz):

Pre-Scan has been conducted to determine the worst-case mode from all possible combinations between available modulations, data rates and antenna ports (if EUT with antenna diversity architecture).

Following channel(s) was (were) selected for the final test as listed below.

MODE	AVAILABLE CHANNEL	TESTED CHANNEL	MODULATION TECHNOLOGY	MODULATION TYPE	DATA RATE (Mbps)
802.11b	1 to 11	1, 6, 11	DSSS	DBPSK	1
802.11g	1 to 11	1, 6, 11	OFDM	BPSK	6
802.11n (HT20)	1 to 11	1, 6, 11	OFDM	BPSK	6.5

Radiated Emission Test (Below 1GHz):

Pre-Scan has been conducted to determine the worst-case mode from all possible combinations between available modulations, data rates and antenna ports (if EUT with antenna diversity architecture).

Following channel(s) was (were) selected for the final test as listed below.

MODE	AVAILABLE CHANNEL	TESTED CHANNEL	MODULATION TECHNOLOGY	MODULATION TYPE	DATA RATE (Mbps)
802.11n (HT20)	1 to 11	6	OFDM	BPSK	6.5

Power Line Conducted Emission Test:

- Pre-Scan has been conducted to determine the worst-case mode from all possible combinations between available modulations, data rates and antenna ports (if EUT with antenna diversity architecture).
- Following channel(s) was (were) selected for the final test as listed below.

MODE	AVAILABLE CHANNEL	TESTED CHANNEL	MODULATION TECHNOLOGY	MODULATION TYPE	DATA RATE (Mbps)
802.11n (HT20)	1 to 11	6	OFDM	BPSK	6.5

Antenna Port Conducted Measurement:

- This item includes all test value of each mode, but only includes spectrum plot of worst value of each mode.
- Pre-Scan has been conducted to determine the worst-case mode from all possible combinations between available modulations, data rates and antenna ports (if EUT with antenna diversity architecture).
- Following channel(s) was (were) selected for the final test as listed below.

MODE	AVAILABLE CHANNEL	TESTED CHANNEL	MODULATION TECHNOLOGY	MODULATION TYPE	DATA RATE (Mbps)
802.11b	1 to 11	1, 6, 11	DSSS	DBPSK	1
802.11g	1 to 11	1, 6, 11	OFDM	BPSK	6
802.11n (HT20)	1 to 11	1, 6, 11	OFDM	BPSK	6.5

Test Condition:

APPLICABLE TO	ENVIRONMENTAL CONDITIONS	INPUT POWER	TESTED BY
RE \geq 1G	24deg. C, 69%RH	120Vac, 60Hz	Alex Ku
RE $<$ 1G	23deg. C, 72%RH	120Vac, 60Hz	Gary Cheng
PLC	19deg. C, 67%RH	120Vac, 60Hz	Wythe Lin
	22deg. C, 71%RH		Gavin Peng
APCM	25deg. C, 60%RH	120Vac, 60Hz	Anderson Chen

3.3 Duty Cycle of Test Signal

Duty cycle of test signal is $\geq 98\%$, duty factor is not required.

802.11b: Duty cycle = 12.45 ms/12.544 ms = 0.993

802.11g: Duty cycle = 2.093 ms/2.129 ms = 0.983

802.11n (HT20): Duty cycle = 1.938 ms/1.975 ms = 0.981

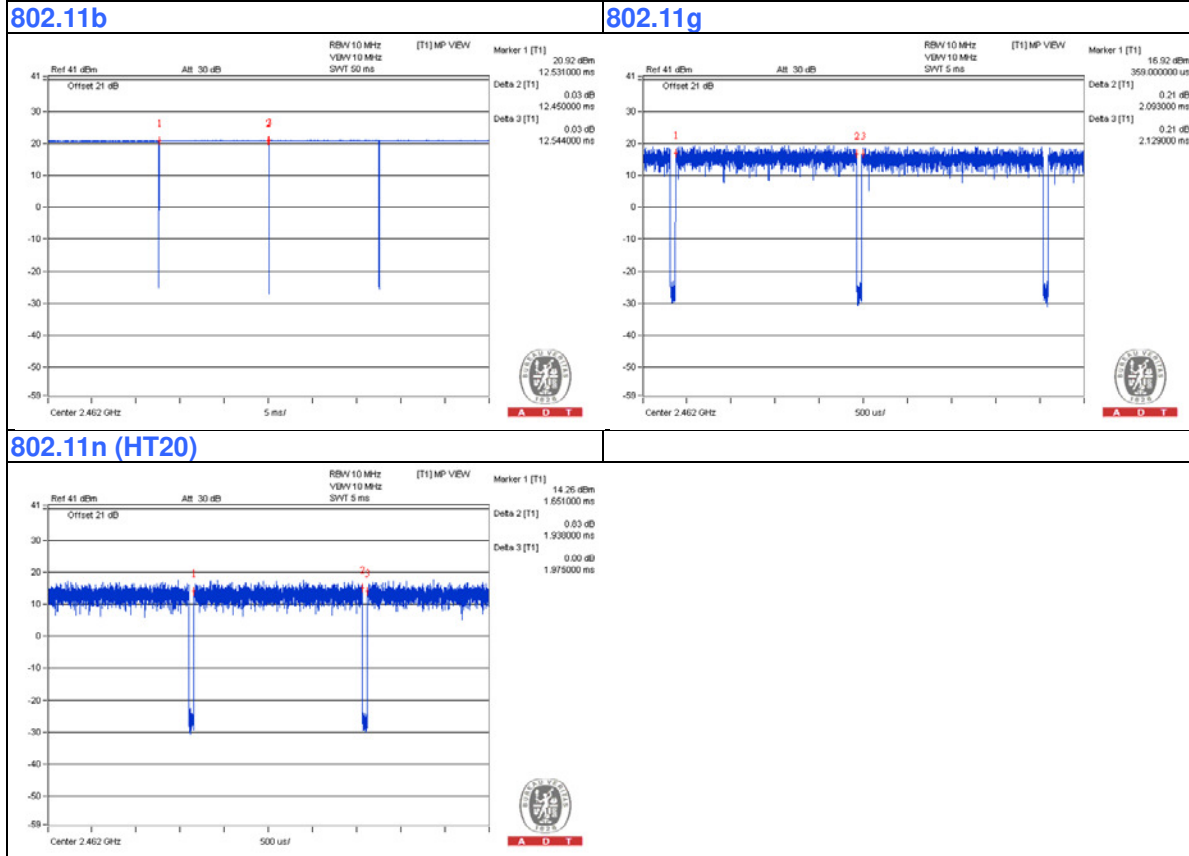

3.4 Description of Support Units

The EUT has been tested as an independent unit together with other necessary accessories or support units. The following support units or accessories were used to form a representative test configuration during the tests.

ID	Product	Brand	Model No.	Serial No.	FCC ID	Remarks
A.	Micro SD card	SanDisk	2G	NA	NA	Provided by Lab
B.	NOTEBOOK COMPUTER	DELL	E5440	6FC7F12	FCC DoC	Provided by Lab
C.	POE	PowerDsine	PD-9001GR/AT/AC	NA	NA	Provided by Lab

Note:

1. All power cords of the above support units are non-shielded (1.8m).

ID	Descriptions	Qty.	Length (m)	Shielding (Yes/No)	Cores (Qty.)	Remarks
1.	RJ45	1	10	No	0	Provided by Lab
2.	mini USB	1	3	Yes	0	Supplied by client
3.	POE cable	1	0.1	No	0	Supplied by client
4.	RJ45	1	1	No	0	Provided by Lab

3.4.1 Configuration of System under Test

For test mode 1:

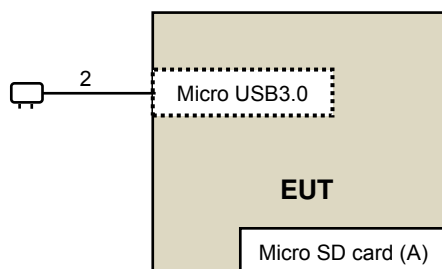

For test mode 2

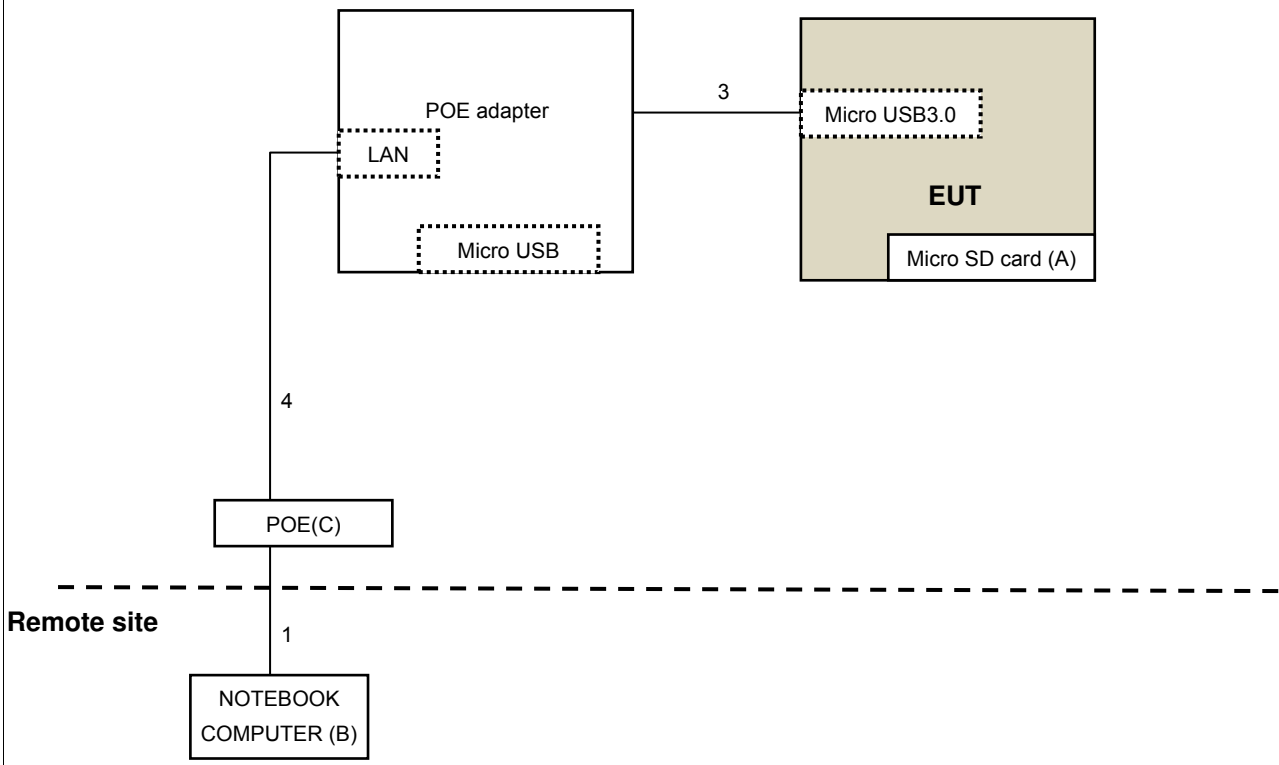

For test mode 3

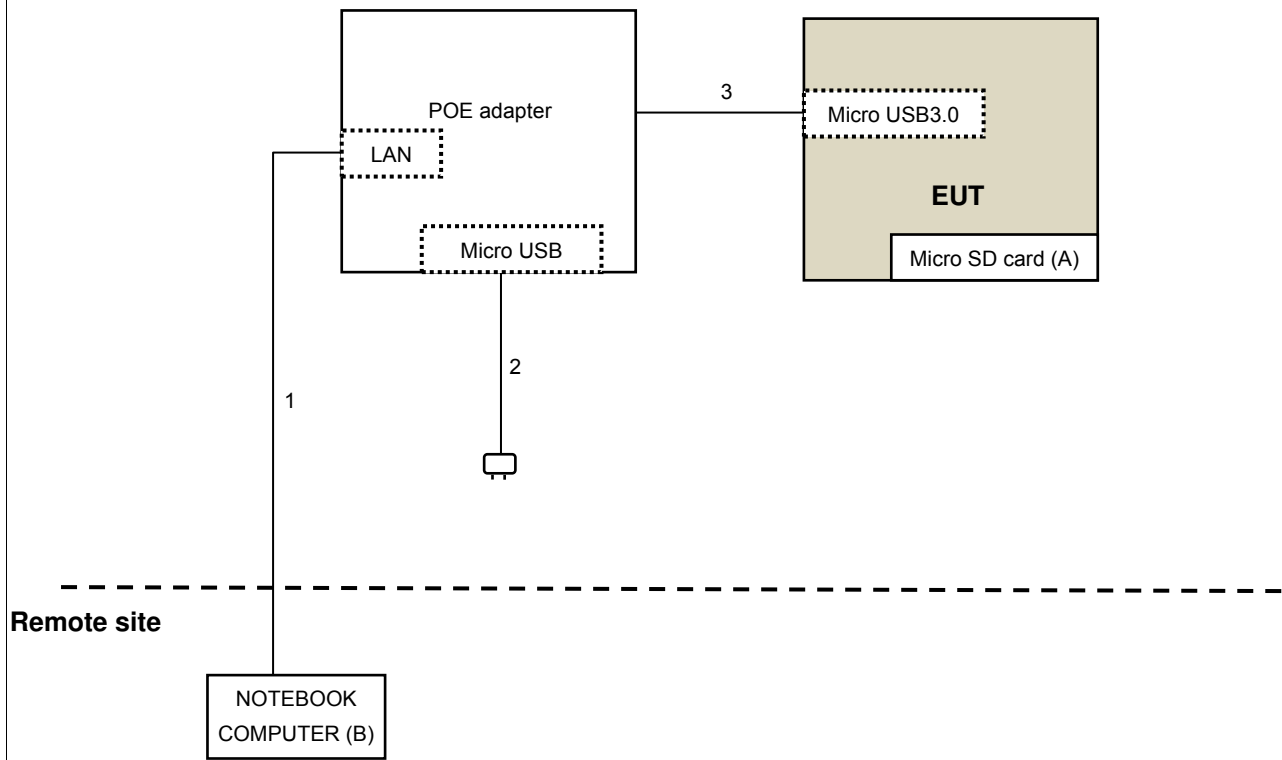

3.5 General Description of Applied Standards

The EUT is a RF Product. According to the specifications of the manufacturer, it must comply with the requirements of the following standards:

FCC Part 15, Subpart C (15.247)
KDB 558074 D01 DTS Meas Guidance v03r05
KDB 662911 D01 Multiple Transmitter Output v02r01
ANSI C63.10-2013

All test items have been performed and recorded as per the above standards.

4 Test Types and Results

4.1 Radiated Emission and Bandedge Measurement

4.1.1 Limits of Radiated Emission and Bandedge Measurement

Radiated emissions which fall in the restricted bands must comply with the radiated emission limits specified as below table. Other emissions shall be at least 20dB below the highest level of the desired power:

Frequencies (MHz)	Field Strength (microvolts/meter)	Measurement Distance (meters)
0.009 ~ 0.490	2400/F(kHz)	300
0.490 ~ 1.705	24000/F(kHz)	30
1.705 ~ 30.0	30	30
30 ~ 88	100	3
88 ~ 216	150	3
216 ~ 960	200	3
Above 960	500	3

NOTE:

1. The lower limit shall apply at the transition frequencies.
2. Emission level (dBuV/m) = 20 log Emission level (uV/m).
3. For frequencies above 1000MHz, the field strength limits are based on average detector, however, the peak field strength of any emission shall not exceed the maximum permitted average limits, specified above by more than 20dB under any condition of modulation.



4.1.2 Test Instruments

For Below 1GHz test:

DESCRIPTION & MANUFACTURER	MODEL NO.	SERIAL NO.	CALIBRATED DATE	CALIBRATED UNTIL
Test Receiver Agilent	N9038A	MY54450088	July 24, 2015	July 23, 2016
Pre-Amplifier ^(*) EMCI	EMC001340	980142	Jan. 20, 2016	Jan. 19, 2018
Loop Antenna ^(*) Electro-Metrics	EM-6879	264	Dec. 16, 2014	Dec. 15, 2016
RF Cable	NA	LOOPCAB-001 LOOPCAB-002	Jan. 18, 2016	Jan. 17, 2017
Pre-Amplifier Mini-Circuits	ZFL-1000VH2 B	AMP-ZFL-01	Nov. 11, 2015	Nov. 10, 2016
Trilog Broadband Antenna SCHWARZBECK	VULB 9168	9168-406	Jan. 04, 2016	Jan. 03, 2017
RF Cable	8D	966-4-1 966-4-2 966-4-3	Apr. 03, 2015	Apr. 02, 2016
Software	ADT_Radiated _V8.7.07	NA	NA	NA
Antenna Tower & Turn Table CT	NA	NA	NA	NA

Note:

1. The calibration interval of the above test instruments is 12 months and the calibrations are traceable to NML/ROC and NIST/USA.
2. *The calibration interval of the above test instruments is 24 months and the calibrations are traceable to NML/ROC and NIST/USA.
3. Loop antenna was used for all emissions below 30 MHz.
4. The test was performed in 966 Chamber No. 4.
5. The FCC Site Registration No. is 292998
6. The CANADA Site Registration No. is 20331-2
- 7 Tested Date: Mar. 03, 2016

**For other test items:**

DESCRIPTION & MANUFACTURER	MODEL NO.	SERIAL NO.	CALIBRATED DATE	CALIBRATED UNTIL
Test Receiver Agilent	N9038A	MY54450088	July 24, 2015	July 23, 2016
Horn_Antenna SCHWARZBECK	BBHA 9120D	9120D-783	Feb. 06, 2015	Feb. 05, 2016
Pre-Amplifier Agilent	8449B	3008A01922	Sep. 19, 2015	Sep. 18, 2016
RF Cable	EMC104-SM- SM-2000 EMC104-SM- SM-5000 EMC104-SM- SM-5000	150318 150323 150324	Mar. 31, 2015	Mar. 30, 2016
Spectrum Analyzer R&S	FSV40	100964	June 26, 2015	June 25, 2016
Pre-Amplifier EMCI	EMC184045	980143	Jan. 16, 2015	Jan. 15, 2016
Horn_Antenna SCHWARZBECK	BBHA 9170	BBHA9170608	Feb. 05, 2015	Feb. 04, 2016
RF Cable	SUCOFLEX 104	329751/4 RF104-204	Dec. 11, 2014	Dec. 10, 2015
Software	ADT_Radiated _V8.7.07	NA	NA	NA
Antenna Tower & Turn Table CT	NA	NA	NA	NA
Spectrum Analyzer R&S	FSP40	100060	May 08, 2015	May 07, 2016
Power Meter Anritsu	ML2495A	1014008	Apr. 28, 2015	Apr. 27, 2016
Power Sensor Anritsu	MA2411B	0917122	Apr. 28, 2015	Apr. 27, 2016

Note:

1. The calibration interval of the above test instruments is 12 months and the calibrations are traceable to NML/ROC and NIST/USA.
2. The test was performed in 966 Chamber No. 4.
3. The FCC Site Registration No. is 292998
4. The CANADA Site Registration No. is 20331-2
5. Tested Date: Oct. 20 to 23, 2015

4.1.3 Test Procedures

- a. The EUT was placed on the top of a rotating table 0.8 meters (for below 1GHz) / 1.5 meters (for above 1GHz) above the ground at 3 meter chamber room for test. The table was rotated 360 degrees to determine the position of the highest radiation.
- b. The EUT was set 3 meters away from the interference-receiving antenna, which was mounted on the top of a variable-height antenna tower.
- c. The height of antenna is varied from one meter to four meters above the ground to determine the maximum value of the field strength. Both horizontal and vertical polarizations of the antenna are set to make the measurement.
- d. For each suspected emission, the EUT was arranged to its worst case and then the antenna was tuned to heights from 1 meter to 4 meters and the rotatable table was turned from 0 degrees to 360 degrees to find the maximum reading.
- e. The test-receiver system was set to quasi-peak detect function and specified bandwidth with maximum hold mode when the test frequency is below 1 GHz.
- f. The test-receiver system was set to peak and average detect function and specified bandwidth with maximum hold mode when the test frequency is above 1 GHz. If the peak reading value also meets average limit, measurement with the average detector is unnecessary.

Note:

1. The resolution bandwidth and video bandwidth of test receiver/spectrum analyzer is 120kHz for Quasi-peak detection (QP) at frequency below 1GHz.
2. The resolution bandwidth of test receiver/spectrum analyzer is 1 MHz and the video bandwidth is 3 MHz for Peak detection (PK) at frequency above 1GHz.
3. The resolution bandwidth of test receiver/spectrum analyzer is 1MHz and the video bandwidth is 3MHz for RMS Average (Duty cycle < 98%) for Average detection (AV) at frequency above 1GHz, then the measurement results was added to a correction factor ($10 \log(1/\text{duty cycle})$).
4. The resolution bandwidth of test receiver/spectrum analyzer is 1MHz and the video bandwidth is 10Hz (Duty cycle $\geq 98\%$) for Average detection (AV) at frequency above 1GHz.
5. All modes of operation were investigated and the worst-case emissions are reported.

4.1.4 Deviation from Test Standard

No deviation.

4.1.5 Test Setup

<Frequency Range below 1GHz>

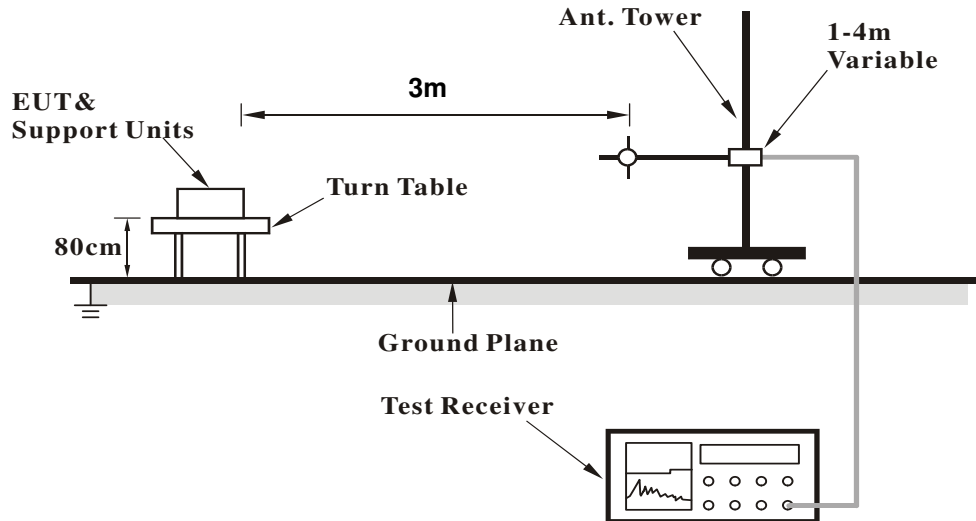

<Frequency Range above 1GHz>

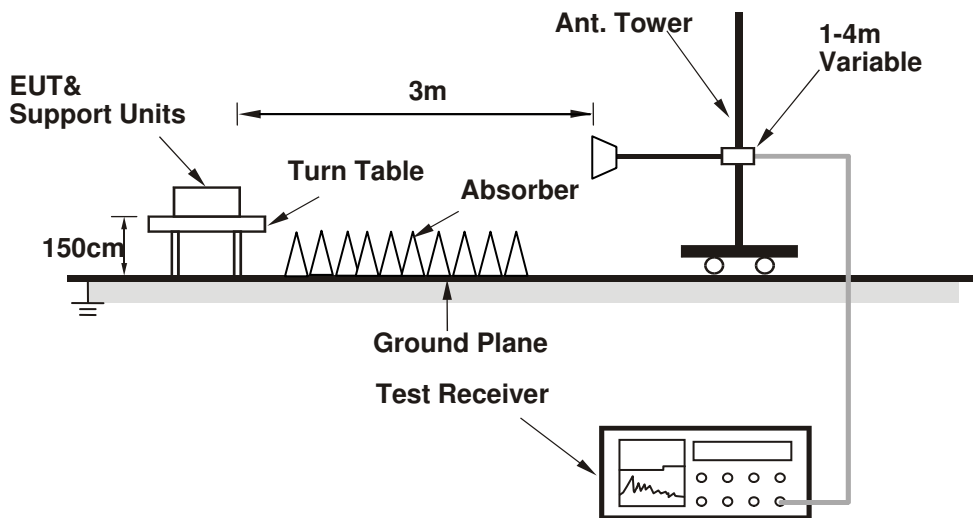

For the actual test configuration, please refer to the attached file (Test Setup Photo).

4.1.6 EUT Operating Conditions

1. Controlling software (Console Paster command [VMC3040 WiFi test command.txt]) has been activated to set the EUT on specific status.

4.1.7 Test Results

Above 1GHz Data

802.11b

CHANNEL	TX Channel 1	DETECTOR FUNCTION	Peak (PK)
FREQUENCY RANGE	1GHz ~ 25GHz		Average (AV)

ANTENNA POLARITY & TEST DISTANCE: HORIZONTAL AT 3 M

NO.	FREQ. (MHz)	EMISSION LEVEL (dBuV/m)	LIMIT (dBuV/m)	MARGIN (dB)	ANTENNA HEIGHT (m)	TABLE ANGLE (Degree)	RAW VALUE (dBuV)	CORRECTION FACTOR (dB/m)
1	2390.00	61.2 PK	74.0	-12.8	1.18 H	354	67.39	-6.19
2	2390.00	53.9 AV	54.0	-0.1	1.18 H	354	60.09	-6.19
3	*2412.00	106.9 PK			1.18 H	354	112.99	-6.09
4	*2412.00	104.4 AV			1.18 H	354	110.49	-6.09
5	4824.00	50.0 PK	74.0	-24.0	1.54 H	336	50.19	-0.19
6	4824.00	46.8 AV	54.0	-7.2	1.54 H	336	46.99	-0.19

ANTENNA POLARITY & TEST DISTANCE: VERTICAL AT 3 M

NO.	FREQ. (MHz)	EMISSION LEVEL (dBuV/m)	LIMIT (dBuV/m)	MARGIN (dB)	ANTENNA HEIGHT (m)	TABLE ANGLE (Degree)	RAW VALUE (dBuV)	CORRECTION FACTOR (dB/m)
1	2390.00	58.3 PK	74.0	-15.7	2.04 V	291	64.49	-6.19
2	2390.00	53.7 AV	54.0	-0.3	2.04 V	291	59.89	-6.19
3	*2412.00	109.1 PK			2.04 V	291	115.19	-6.09
4	*2412.00	106.5 AV			2.04 V	291	112.59	-6.09
5	4824.00	52.0 PK	74.0	-22.0	1.42 V	14	52.19	-0.19
6	4824.00	48.4 AV	54.0	-5.6	1.42 V	14	48.59	-0.19

REMARKS:

1. Emission Level(dBuV/m) = Raw Value(dBuV) + Correction Factor(dB/m)
2. Correction Factor(dB/m) = Antenna Factor(dB/m) + Cable Factor(dB) – Pre-Amplifier Factor(dB)
3. The other emission levels were very low against the limit.
4. Margin value = Emission Level – Limit value
5. " * ": Fundamental frequency.

CHANNEL	TX Channel 6	DETECTOR FUNCTION	Peak (PK)
FREQUENCY RANGE	1GHz ~ 25GHz		Average (AV)

ANTENNA POLARITY & TEST DISTANCE: HORIZONTAL AT 3 M

NO.	FREQ. (MHz)	EMISSION LEVEL (dBuV/m)	LIMIT (dBuV/m)	MARGIN (dB)	ANTENNA HEIGHT (m)	TABLE ANGLE (Degree)	RAW VALUE (dBuV)	CORRECTION FACTOR (dB/m)
1	*2437.00	108.9 PK			1.30 H	109	112.99	-4.09
2	*2437.00	105.2 AV			1.30 H	109	109.29	-4.09
3	4874.00	54.7 PK	74.0	-19.3	1.46 H	174	49.97	4.73
4	4874.00	53.4 AV	54.0	-0.6	1.46 H	174	48.67	4.73
5	7311.00	57.3 PK	74.0	-16.7	1.00 H	89	47.96	9.34
6	7311.00	53.1 AV	54.0	-0.9	1.00 H	89	43.76	9.34

ANTENNA POLARITY & TEST DISTANCE: VERTICAL AT 3 M

NO.	FREQ. (MHz)	EMISSION LEVEL (dBuV/m)	LIMIT (dBuV/m)	MARGIN (dB)	ANTENNA HEIGHT (m)	TABLE ANGLE (Degree)	RAW VALUE (dBuV)	CORRECTION FACTOR (dB/m)
1	*2437.00	110.5 PK			1.92 V	297	114.59	-4.09
2	*2437.00	107.9 AV			1.92 V	297	111.99	-4.09
3	4874.00	54.3 PK	74.0	-19.7	1.59 V	360	49.57	4.73
4	4874.00	52.7 AV	54.0	-1.3	1.59 V	360	47.97	4.73
5	7311.00	55.7 PK	74.0	-18.3	2.22 V	158	46.36	9.34
6	7311.00	51.2 AV	54.0	-2.8	2.22 V	158	41.86	9.34

REMARKS:

1. Emission Level(dBuV/m) = Raw Value(dBuV) + Correction Factor(dB/m)
2. Correction Factor(dB/m) = Antenna Factor(dB/m) + Cable Factor(dB) – Pre-Amplifier Factor(dB)
3. The other emission levels were very low against the limit.
4. Margin value = Emission Level – Limit value
5. " * ": Fundamental frequency.

CHANNEL	TX Channel 11	DETECTOR FUNCTION	Peak (PK)
FREQUENCY RANGE	1GHz ~ 25GHz		Average (AV)

ANTENNA POLARITY & TEST DISTANCE: HORIZONTAL AT 3 M

NO.	FREQ. (MHz)	EMISSION LEVEL (dBuV/m)	LIMIT (dBuV/m)	MARGIN (dB)	ANTENNA HEIGHT (m)	TABLE ANGLE (Degree)	RAW VALUE (dBuV)	CORRECTION FACTOR (dB/m)
1	*2462.00	107.1 PK			1.91 H	116	113.01	-5.91
2	*2462.00	104.2 AV			1.91 H	116	110.11	-5.91
3	2483.50	57.2 PK	74.0	-16.8	1.91 H	116	63.02	-5.82
4	2483.50	51.0 AV	54.0	-3.0	1.91 H	116	56.82	-5.82
5	4924.00	49.6 PK	74.0	-24.4	1.50 H	342	49.46	0.14
6	4924.00	46.4 AV	54.0	-7.6	1.50 H	342	46.26	0.14
7	7386.00	51.6 PK	74.0	-22.4	1.04 H	57	45.14	6.46
8	7386.00	46.1 AV	54.0	-7.9	1.04 H	57	39.64	6.46

ANTENNA POLARITY & TEST DISTANCE: VERTICAL AT 3 M

NO.	FREQ. (MHz)	EMISSION LEVEL (dBuV/m)	LIMIT (dBuV/m)	MARGIN (dB)	ANTENNA HEIGHT (m)	TABLE ANGLE (Degree)	RAW VALUE (dBuV)	CORRECTION FACTOR (dB/m)
1	*2462.00	109.4 PK			1.67 V	293	115.31	-5.91
2	*2462.00	106.7 AV			1.67 V	293	112.61	-5.91
3	2483.50	58.5 PK	74.0	-15.5	1.67 V	293	64.32	-5.82
4	2483.50	53.3 AV	54.0	-0.7	1.67 V	293	59.12	-5.82
5	4924.00	51.8 PK	74.0	-22.2	1.40 V	23	51.66	0.14
6	4924.00	48.5 AV	54.0	-5.5	1.40 V	23	48.36	0.14
7	7386.00	53.8 PK	74.0	-20.2	2.50 V	298	47.34	6.46
8	7386.00	47.7 AV	54.0	-6.3	2.50 V	298	41.24	6.46

REMARKS:

1. Emission Level(dBuV/m) = Raw Value(dBuV) + Correction Factor(dB/m)
2. Correction Factor(dB/m) = Antenna Factor(dB/m) + Cable Factor(dB) – Pre-Amplifier Factor(dB)
3. The other emission levels were very low against the limit.
4. Margin value = Emission Level – Limit value
5. " * ": Fundamental frequency.

802.11g

CHANNEL	TX Channel 1	DETECTOR FUNCTION	Peak (PK)
FREQUENCY RANGE	1GHz ~ 25GHz		Average (AV)

ANTENNA POLARITY & TEST DISTANCE: HORIZONTAL AT 3 M

NO.	FREQ. (MHz)	EMISSION LEVEL (dBuV/m)	LIMIT (dBuV/m)	MARGIN (dB)	ANTENNA HEIGHT (m)	TABLE ANGLE (Degree)	RAW VALUE (dBuV)	CORRECTION FACTOR (dB/m)
1	2390.00	68.7 PK	74.0	-5.3	1.73 H	92	74.89	-6.19
2	2390.00	52.5 AV	54.0	-1.5	1.73 H	92	58.69	-6.19
3	*2412.00	104.4 PK			1.73 H	92	110.49	-6.09
4	*2412.00	91.7 AV			1.73 H	92	97.79	-6.09
5	4824.00	51.1 PK	74.0	-22.9	1.44 H	183	51.29	-0.19
6	4824.00	37.9 AV	54.0	-16.1	1.44 H	183	38.09	-0.19

ANTENNA POLARITY & TEST DISTANCE: VERTICAL AT 3 M

NO.	FREQ. (MHz)	EMISSION LEVEL (dBuV/m)	LIMIT (dBuV/m)	MARGIN (dB)	ANTENNA HEIGHT (m)	TABLE ANGLE (Degree)	RAW VALUE (dBuV)	CORRECTION FACTOR (dB/m)
1	2390.00	73.3 PK	74.0	-0.7	1.81 V	329	79.49	-6.19
2	2390.00	53.9 AV	54.0	-0.1	1.81 V	329	60.09	-6.19
3	*2412.00	106.4 PK			1.81 V	329	112.49	-6.09
4	*2412.00	92.6 AV			1.81 V	329	98.69	-6.09
5	4824.00	49.0 PK	74.0	-25.0	1.46 V	115	49.19	-0.19
6	4824.00	35.7 AV	54.0	-18.3	1.46 V	115	35.89	-0.19

REMARKS:

1. Emission Level(dBuV/m) = Raw Value(dBuV) + Correction Factor(dB/m)
2. Correction Factor(dB/m) = Antenna Factor(dB/m) + Cable Factor(dB) – Pre-Amplifier Factor(dB)
3. The other emission levels were very low against the limit.
4. Margin value = Emission Level – Limit value
5. " * ": Fundamental frequency.

CHANNEL	TX Channel 6	DETECTOR FUNCTION	Peak (PK)
FREQUENCY RANGE	1GHz ~ 25GHz		Average (AV)

ANTENNA POLARITY & TEST DISTANCE: HORIZONTAL AT 3 M

NO.	FREQ. (MHz)	EMISSION LEVEL (dBuV/m)	LIMIT (dBuV/m)	MARGIN (dB)	ANTENNA HEIGHT (m)	TABLE ANGLE (Degree)	RAW VALUE (dBuV)	CORRECTION FACTOR (dB/m)
1	2310.00	66.7 PK	74.0	-7.3	1.57 H	113	73.20	-6.50
2	2310.00	48.1 AV	54.0	-5.9	1.57 H	113	54.60	-6.50
3	*2437.00	110.6 PK			1.57 H	113	116.60	-6.00
4	*2437.00	96.3 AV			1.57 H	113	102.30	-6.00
5	2483.50	71.6 PK	74.0	-2.4	1.57 H	113	77.42	-5.82
6	2483.50	52.6 AV	54.0	-1.4	1.57 H	113	58.42	-5.82
7	4874.00	50.7 PK	74.0	-23.3	1.48 H	183	50.69	0.01
8	4874.00	37.6 AV	54.0	-16.4	1.48 H	183	37.59	0.01
9	7311.00	60.7 PK	74.0	-13.3	1.01 H	62	54.39	6.31
10	7311.00	46.0 AV	54.0	-8.0	1.01 H	62	39.69	6.31

ANTENNA POLARITY & TEST DISTANCE: VERTICAL AT 3 M

NO.	FREQ. (MHz)	EMISSION LEVEL (dBuV/m)	LIMIT (dBuV/m)	MARGIN (dB)	ANTENNA HEIGHT (m)	TABLE ANGLE (Degree)	RAW VALUE (dBuV)	CORRECTION FACTOR (dB/m)
1	2310.00	69.2 PK	74.0	-4.8	1.95 V	292	75.70	-6.50
2	2310.00	51.2 AV	54.0	-2.8	1.95 V	292	57.70	-6.50
3	*2437.00	113.0 PK			1.95 V	292	119.00	-6.00
4	*2437.00	98.7 AV			1.95 V	292	104.70	-6.00
5	2483.50	73.2 PK	74.0	-0.8	1.95 V	292	79.02	-5.82
6	2483.50	53.1 AV	54.0	-0.9	1.95 V	292	58.92	-5.82
7	4874.00	49.3 PK	74.0	-24.7	1.44 V	121	49.29	0.01
8	4874.00	36.1 AV	54.0	-17.9	1.44 V	121	36.09	0.01
9	7311.00	57.6 PK	74.0	-16.4	1.42 V	282	51.29	6.31
10	7311.00	44.2 AV	54.0	-9.8	1.42 V	282	37.89	6.31

REMARKS:

1. Emission Level(dBuV/m) = Raw Value(dBuV) + Correction Factor(dB/m)
2. Correction Factor(dB/m) = Antenna Factor(dB/m) + Cable Factor(dB) – Pre-Amplifier Factor(dB)
3. The other emission levels were very low against the limit.
4. Margin value = Emission Level – Limit value
5. " * ": Fundamental frequency.

CHANNEL	TX Channel 11	DETECTOR FUNCTION	Peak (PK)
FREQUENCY RANGE	1GHz ~ 25GHz		Average (AV)

ANTENNA POLARITY & TEST DISTANCE: HORIZONTAL AT 3 M

NO.	FREQ. (MHz)	EMISSION LEVEL (dBuV/m)	LIMIT (dBuV/m)	MARGIN (dB)	ANTENNA HEIGHT (m)	TABLE ANGLE (Degree)	RAW VALUE (dBuV)	CORRECTION FACTOR (dB/m)
1	*2462.00	105.9 PK			1.19 H	93	111.81	-5.91
2	*2462.00	92.5 AV			1.19 H	93	98.41	-5.91
3	2483.50	73.2 PK	74.0	-0.8	1.19 H	93	79.02	-5.82
4	2483.50	53.8 AV	54.0	-0.2	1.19 H	93	59.62	-5.82
5	4924.00	50.5 PK	74.0	-23.5	1.52 H	197	50.36	0.14
6	4924.00	37.7 AV	54.0	-16.3	1.52 H	197	37.56	0.14
7	7386.00	60.3 PK	74.0	-13.7	1.03 H	48	53.84	6.46
8	7386.00	45.8 AV	54.0	-8.2	1.03 H	48	39.34	6.46

ANTENNA POLARITY & TEST DISTANCE: VERTICAL AT 3 M

NO.	FREQ. (MHz)	EMISSION LEVEL (dBuV/m)	LIMIT (dBuV/m)	MARGIN (dB)	ANTENNA HEIGHT (m)	TABLE ANGLE (Degree)	RAW VALUE (dBuV)	CORRECTION FACTOR (dB/m)
1	*2462.00	104.4 PK			1.35 V	290	110.31	-5.91
2	*2462.00	91.0 AV			1.35 V	290	96.91	-5.91
3	2483.50	71.6 PK	74.0	-2.4	1.35 V	290	77.42	-5.82
4	2483.50	52.6 AV	54.0	-1.4	1.35 V	290	58.42	-5.82
5	4924.00	49.9 PK	74.0	-24.1	1.48 V	131	49.76	0.14
6	4924.00	36.4 AV	54.0	-17.6	1.48 V	131	36.26	0.14
7	7386.00	57.6 PK	74.0	-16.4	1.41 V	281	51.14	6.46
8	7386.00	44.1 AV	54.0	-9.9	1.41 V	281	37.64	6.46

REMARKS:

1. Emission Level(dBuV/m) = Raw Value(dBuV) + Correction Factor(dB/m)
2. Correction Factor(dB/m) = Antenna Factor(dB/m) + Cable Factor(dB) – Pre-Amplifier Factor(dB)
3. The other emission levels were very low against the limit.
4. Margin value = Emission Level – Limit value
5. " * ": Fundamental frequency.

802.11n (HT20)

CHANNEL	TX Channel 1	DETECTOR FUNCTION	Peak (PK)
FREQUENCY RANGE	1GHz ~ 25GHz		Average (AV)

ANTENNA POLARITY & TEST DISTANCE: HORIZONTAL AT 3 M

NO.	FREQ. (MHz)	EMISSION LEVEL (dBuV/m)	LIMIT (dBuV/m)	MARGIN (dB)	ANTENNA HEIGHT (m)	TABLE ANGLE (Degree)	RAW VALUE (dBuV)	CORRECTION FACTOR (dB/m)
1	2390.00	70.1 PK	74.0	-3.9	1.54 H	114	76.29	-6.19
2	2390.00	51.7 AV	54.0	-2.3	1.54 H	114	57.89	-6.19
3	*2412.00	103.7 PK			1.54 H	114	109.79	-6.09
4	*2412.00	89.6 AV			1.54 H	114	95.69	-6.09
5	4824.00	51.4 PK	74.0	-22.6	1.44 H	175	51.59	-0.19
6	4824.00	38.2 AV	54.0	-15.8	1.44 H	175	38.39	-0.19

ANTENNA POLARITY & TEST DISTANCE: VERTICAL AT 3 M

NO.	FREQ. (MHz)	EMISSION LEVEL (dBuV/m)	LIMIT (dBuV/m)	MARGIN (dB)	ANTENNA HEIGHT (m)	TABLE ANGLE (Degree)	RAW VALUE (dBuV)	CORRECTION FACTOR (dB/m)
1	2390.00	71.5 PK	74.0	-2.5	1.18 V	298	77.69	-6.19
2	2390.00	53.8 AV	54.0	-0.2	1.18 V	298	59.99	-6.19
3	*2412.00	106.0 PK			1.18 V	298	112.09	-6.09
4	*2412.00	91.6 AV			1.18 V	298	97.69	-6.09
5	4824.00	48.9 PK	74.0	-25.1	1.48 V	147	49.09	-0.19
6	4824.00	35.5 AV	54.0	-18.5	1.48 V	147	35.69	-0.19

REMARKS:

1. Emission Level(dBuV/m) = Raw Value(dBuV) + Correction Factor(dB/m)
2. Correction Factor(dB/m) = Antenna Factor(dB/m) + Cable Factor(dB) – Pre-Amplifier Factor(dB)
3. The other emission levels were very low against the limit.
4. Margin value = Emission Level – Limit value
5. " * ": Fundamental frequency.

CHANNEL	TX Channel 6	DETECTOR FUNCTION	Peak (PK)
FREQUENCY RANGE	1GHz ~ 25GHz		Average (AV)

ANTENNA POLARITY & TEST DISTANCE: HORIZONTAL AT 3 M

NO.	FREQ. (MHz)	EMISSION LEVEL (dBuV/m)	LIMIT (dBuV/m)	MARGIN (dB)	ANTENNA HEIGHT (m)	TABLE ANGLE (Degree)	RAW VALUE (dBuV)	CORRECTION FACTOR (dB/m)
1	2390.00	65.3 PK	74.0	-8.7	1.57 H	111	71.49	-6.19
2	2390.00	45.9 AV	54.0	-8.1	1.57 H	111	52.09	-6.19
3	*2437.00	111.0 PK			1.57 H	111	117.00	-6.00
4	*2437.00	96.2 AV			1.57 H	111	102.20	-6.00
5	2483.50	73.0 PK	74.0	-1.0	1.57 H	111	78.82	-5.82
6	2483.50	51.4 AV	54.0	-2.6	1.57 H	111	57.22	-5.82
7	4874.00	51.3 PK	74.0	-22.7	1.49 H	186	51.29	0.01
8	4874.00	38.1 AV	54.0	-15.9	1.49 H	186	38.09	0.01
9	7311.00	60.9 PK	74.0	-13.1	1.02 H	64	54.59	6.31
10	7311.00	46.0 AV	54.0	-8.0	1.02 H	64	39.69	6.31

ANTENNA POLARITY & TEST DISTANCE: VERTICAL AT 3 M

NO.	FREQ. (MHz)	EMISSION LEVEL (dBuV/m)	LIMIT (dBuV/m)	MARGIN (dB)	ANTENNA HEIGHT (m)	TABLE ANGLE (Degree)	RAW VALUE (dBuV)	CORRECTION FACTOR (dB/m)
1	2390.00	70.1 PK	74.0	-3.9	1.86 V	299	76.29	-6.19
2	2390.00	50.5 AV	54.0	-3.5	1.86 V	299	56.69	-6.19
3	*2437.00	111.8 PK			1.86 V	299	117.80	-6.00
4	*2437.00	97.5 AV			1.86 V	299	103.50	-6.00
5	2483.50	68.9 PK	74.0	-5.1	1.86 V	299	74.72	-5.82
6	2483.50	49.9 AV	54.0	-4.1	1.86 V	299	55.72	-5.82
7	4874.00	49.4 PK	74.0	-24.6	1.44 V	134	49.39	0.01
8	4874.00	36.0 AV	54.0	-18.0	1.44 V	134	35.99	0.01
9	7311.00	58.1 PK	74.0	-15.9	1.42 V	278	51.79	6.31
10	7311.00	44.7 AV	54.0	-9.3	1.42 V	278	38.39	6.31

REMARKS:

1. Emission Level(dBuV/m) = Raw Value(dBuV) + Correction Factor(dB/m)
2. Correction Factor(dB/m) = Antenna Factor(dB/m) + Cable Factor(dB) – Pre-Amplifier Factor(dB)
3. The other emission levels were very low against the limit.
4. Margin value = Emission Level – Limit value
5. " * ": Fundamental frequency.



CHANNEL	TX Channel 11	DETECTOR FUNCTION	Peak (PK)
FREQUENCY RANGE	1GHz ~ 25GHz		Average (AV)

ANTENNA POLARITY & TEST DISTANCE: HORIZONTAL AT 3 M

NO.	FREQ. (MHz)	EMISSION LEVEL (dBuV/m)	LIMIT (dBuV/m)	MARGIN (dB)	ANTENNA HEIGHT (m)	TABLE ANGLE (Degree)	RAW VALUE (dBuV)	CORRECTION FACTOR (dB/m)
1	*2462.00	103.3 PK			1.59 H	111	109.21	-5.91
2	*2462.00	89.1 AV			1.59 H	111	95.01	-5.91
3	2483.50	71.9 PK	74.0	-2.1	1.59 H	111	77.72	-5.82
4	2483.50	51.6 AV	54.0	-2.4	1.59 H	111	57.42	-5.82
5	4924.00	51.3 PK	74.0	-22.7	1.55 H	200	51.16	0.14
6	4924.00	37.8 AV	54.0	-16.2	1.55 H	200	37.66	0.14
7	7386.00	60.6 PK	74.0	-13.4	1.00 H	54	54.14	6.46
8	7386.00	46.0 AV	54.0	-8.0	1.00 H	54	39.54	6.46

ANTENNA POLARITY & TEST DISTANCE: VERTICAL AT 3 M

NO.	FREQ. (MHz)	EMISSION LEVEL (dBuV/m)	LIMIT (dBuV/m)	MARGIN (dB)	ANTENNA HEIGHT (m)	TABLE ANGLE (Degree)	RAW VALUE (dBuV)	CORRECTION FACTOR (dB/m)
1	*2462.00	103.7 PK			2.22 V	293	109.61	-5.91
2	*2462.00	90.2 AV			2.22 V	293	96.11	-5.91
3	2483.50	72.5 PK	74.0	-1.5	2.22 V	293	78.32	-5.82
4	2483.50	53.8 AV	54.0	-0.2	2.22 V	293	59.62	-5.82
5	4924.00	50.1 PK	74.0	-23.9	1.38 V	147	49.96	0.14
6	4924.00	36.5 AV	54.0	-17.5	1.38 V	147	36.36	0.14
7	7386.00	57.7 PK	74.0	-16.3	1.38 V	274	51.24	6.46
8	7386.00	44.5 AV	54.0	-9.5	1.38 V	274	38.04	6.46

REMARKS:

1. Emission Level(dBuV/m) = Raw Value(dBuV) + Correction Factor(dB/m)
2. Correction Factor(dB/m) = Antenna Factor(dB/m) + Cable Factor(dB) – Pre-Amplifier Factor(dB)
3. The other emission levels were very low against the limit.
4. Margin value = Emission Level – Limit value
5. " * ": Fundamental frequency.

Below 1GHz Data

802.11n (HT20)

CHANNEL	TX Channel 6	DETECTOR FUNCTION	Quasi-Peak (QP)
FREQUENCY RANGE	30MHz ~ 1GHz		

ANTENNA POLARITY & TEST DISTANCE: HORIZONTAL AT 3 M

NO.	FREQ. (MHz)	EMISSION LEVEL (dBuV/m)	LIMIT (dBuV/m)	MARGIN (dB)	ANTENNA HEIGHT (m)	TABLE ANGLE (Degree)	RAW VALUE (dBuV)	CORRECTION FACTOR (dB/m)
1	47.53	31.0 QP	40.0	-9.0	3.00 H	241	39.85	-8.85
2	79.35	36.1 QP	40.0	-3.9	2.50 H	30	49.53	-13.40
3	125.01	36.2 QP	43.5	-7.3	2.50 H	62	46.51	-10.31
4	250.00	39.2 QP	46.0	-6.8	1.00 H	250	49.08	-9.84
5	336.16	42.0 QP	46.0	-4.0	1.00 H	17	48.87	-6.86
6	564.96	36.1 QP	46.0	-9.9	1.50 H	265	37.76	-1.68

ANTENNA POLARITY & TEST DISTANCE: VERTICAL AT 3 M

NO.	FREQ. (MHz)	EMISSION LEVEL (dBuV/m)	LIMIT (dBuV/m)	MARGIN (dB)	ANTENNA HEIGHT (m)	TABLE ANGLE (Degree)	RAW VALUE (dBuV)	CORRECTION FACTOR (dB/m)
1	37.73	33.8 QP	40.0	-6.2	1.00 V	19	43.17	-9.34
2	78.26	35.5 QP	40.0	-4.5	1.00 V	200	48.67	-13.21
3	250.00	35.2 QP	46.0	-10.8	1.00 V	272	45.03	-9.84
4	336.01	33.1 QP	46.0	-12.9	1.50 V	207	39.92	-6.86
5	388.78	41.7 QP	46.0	-4.3	1.50 V	197	47.39	-5.69
6	575.09	32.9 QP	46.0	-13.1	1.50 V	0	34.31	-1.37

REMARKS:

1. Emission Level(dBuV/m) = Raw Value(dBuV) + Correction Factor(dB/m)
2. Correction Factor(dB/m) = Antenna Factor(dB/m) + Cable Factor(dB) – Pre-Amplifier Factor(dB)
3. The other emission levels were very low against the limit.
4. Margin value = Emission Level – Limit value

4.2 Conducted Emission Measurement

4.2.1 Limits of Conducted Emission Measurement

Frequency (MHz)	Conducted Limit (dBuV)	
	Quasi-peak	Average
0.15 - 0.5	66 - 56	56 - 46
0.50 - 5.0	56	46
5.0 - 30.0	60	50

Note: 1. The lower limit shall apply at the transition frequencies.

2. The limit decreases in line with the logarithm of the frequency in the range of 0.15 to 0.50MHz.

4.2.2 Test Instruments

DESCRIPTION & MANUFACTURER	MODEL NO.	SERIAL NO.	CALIBRATED DATE	CALIBRATED UNTIL
Test Receiver R&S	ESCS 30	100375	May 06, 2015	May 05, 2016
Line-Impedance Stabilization Network (for EUT) SCHWARZBECK	NSLK-8127	8127-522	Sep. 01, 2015	Aug. 31, 2016
Line-Impedance Stabilization Network (for Peripheral) R&S	ENV216	100072	June 11, 2015	June 10, 2016
RF Cable	5D-FB	COCCAB-001	Mar. 08, 2016	Mar. 07, 2017
50 ohms Terminator	N/A	EMC-03	Sep. 23, 2015	Sep. 22, 2016
50 ohms Terminator	N/A	EMC-02	Oct. 01, 2015	Sep. 30, 2016
50 ohms Terminator	E1-011315	13	Dec. 11 2015	Dec. 10 2016
Software BVADT	BVADT_Cond_ V7.3.7.3	NA	NA	NA

Note:

1. The calibration interval of the above test instruments are 12 months and the calibrations are traceable to NML/ROC and NIST/USA.
2. The test was performed in Shielded Room No. C.
3. The VCCI Con C Registration No. is C-3611.
4. Tested Date: Mar. 09 to 25, 2016

4.2.3 Test Procedures

- a. The EUT was placed 0.4 meters from the conducting wall of the shielded room with EUT being connected to the power mains through a line impedance stabilization network (LISN). Other support units were connected to the power mains through another LISN. The two LISNs provide 50 ohm/ 50uH of coupling impedance for the measuring instrument.
- b. Both lines of the power mains connected to the EUT were checked for maximum conducted interference.
- c. The frequency range from 150kHz to 30MHz was searched. Emission levels under (Limit - 20dB) was not recorded.

NOTE: The resolution bandwidth and video bandwidth of test receiver is 9kHz for quasi-peak detection (QP) and average detection (AV) at frequency 0.15MHz-30MHz.

4.2.4 Deviation from Test Standard

No deviation.

4.2.5 Test Setup

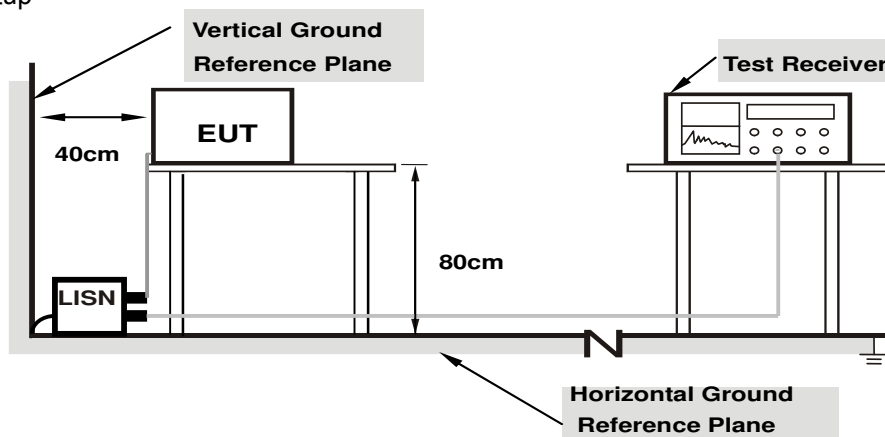

Note: 1.Support units were connected to second LISN.

For the actual test configuration, please refer to the attached file (Test Setup Photo).

4.2.6 EUT Operating Conditions

Same as 4.1.6.

4.2.7 Test Results (Mode 1)

Phase	Line (L)	Detector Function	Quasi-Peak (QP) / Average (AV)
-------	----------	-------------------	--------------------------------

Phase Of Power : Line (L)										
No	Frequency (MHz)	Correction Factor (dB)	Reading Value (dBuV)		Emission Level (dBuV)		Limit (dBuV)		Margin (dB)	
			Q.P.	AV.	Q.P.	AV.	Q.P.	AV.	Q.P.	AV.
1	0.15000	10.32	31.61	24.34	41.93	34.66	66.00	56.00	-24.07	-21.34
2	0.44691	10.29	20.32	13.05	30.61	23.34	56.93	46.93	-26.32	-23.59
3	0.90781	10.24	14.77	2.28	25.01	12.52	56.00	46.00	-30.99	-33.48
4	2.09766	10.27	16.80	2.16	27.07	12.43	56.00	46.00	-28.93	-33.57
5	14.27344	10.75	22.02	14.61	32.77	25.36	60.00	50.00	-27.23	-24.64
6	17.69141	10.88	25.97	22.67	36.85	33.55	60.00	50.00	-23.15	-16.45

Remarks:

1. Q.P. and AV. are abbreviations of quasi-peak and average individually.
2. The emission levels of other frequencies were very low against the limit.
3. Margin value = Emission level – Limit value
4. Correction factor = Insertion loss + Cable loss
5. Emission Level = Correction Factor + Reading Value

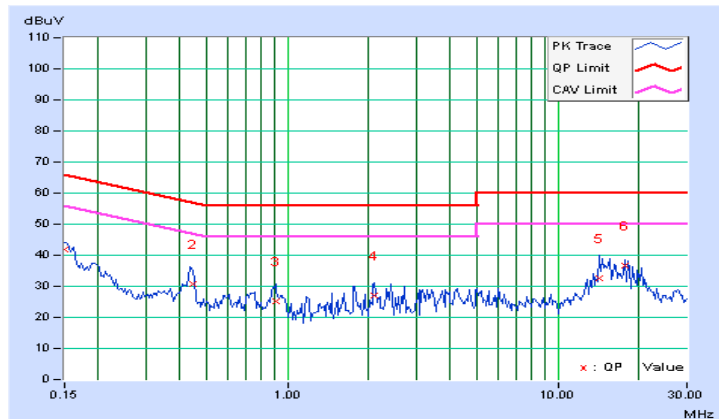

Phase	Neutral (N)	Detector Function	Quasi-Peak (QP) / Average (AV)
-------	-------------	-------------------	--------------------------------

Phase Of Power : Neutral (N)										
No	Frequency (MHz)	Correction Factor (dB)	Reading Value (dBuV)		Emission Level (dBuV)		Limit (dBuV)		Margin (dB)	
			Q.P.	AV.	Q.P.	AV.	Q.P.	AV.	Q.P.	AV.
1	0.15391	10.30	27.82	16.50	38.12	26.80	65.79	55.79	-27.66	-28.98
2	0.18125	10.28	22.98	8.12	33.26	18.40	64.43	54.43	-31.17	-36.03
3	0.43516	10.28	25.35	22.17	35.63	32.45	57.15	47.15	-21.53	-14.71
4	15.10156	10.81	21.46	12.36	32.27	23.17	60.00	50.00	-27.73	-26.83
5	17.69531	10.90	26.90	23.11	37.80	34.01	60.00	50.00	-22.20	-15.99
6	19.70703	10.97	24.72	20.35	35.69	31.32	60.00	50.00	-24.31	-18.68

Remarks:

1. Q.P. and AV. are abbreviations of quasi-peak and average individually.
2. The emission levels of other frequencies were very low against the limit.
3. Margin value = Emission level – Limit value
4. Correction factor = Insertion loss + Cable loss
5. Emission Level = Correction Factor + Reading Value

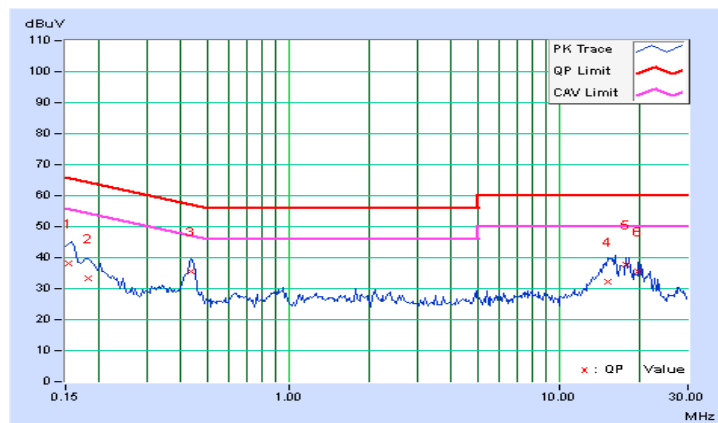

4.2.8 Test Results (Mode 2)

Phase	Line (L)	Detector Function	Quasi-Peak (QP) / Average (AV)
-------	----------	-------------------	--------------------------------

Phase Of Power : Line (L)										
No	Frequency (MHz)	Correction Factor (dB)	Reading Value (dBuV)		Emission Level (dBuV)		Limit (dBuV)		Margin (dB)	
			Q.P.	AV.	Q.P.	AV.	Q.P.	AV.	Q.P.	AV.
1	0.15000	10.26	33.26	22.04	43.52	32.30	66.00	56.00	-22.48	-23.70
2	0.42734	10.24	32.10	26.10	42.34	36.34	57.30	47.30	-14.97	-10.97
3	0.85703	10.19	17.99	12.03	28.18	22.22	56.00	46.00	-27.82	-23.78
4	16.23047	10.81	38.65	36.07	49.46	46.88	60.00	50.00	-10.54	-3.12
5	19.71094	10.91	31.49	28.36	42.40	39.27	60.00	50.00	-17.60	-10.73
6	23.12891	10.96	32.44	30.64	43.40	41.60	60.00	50.00	-16.60	-8.40

Remarks:

1. Q.P. and AV. are abbreviations of quasi-peak and average individually.
2. The emission levels of other frequencies were very low against the limit.
3. Margin value = Emission level – Limit value
4. Correction factor = Insertion loss + Cable loss
5. Emission Level = Correction Factor + Reading Value

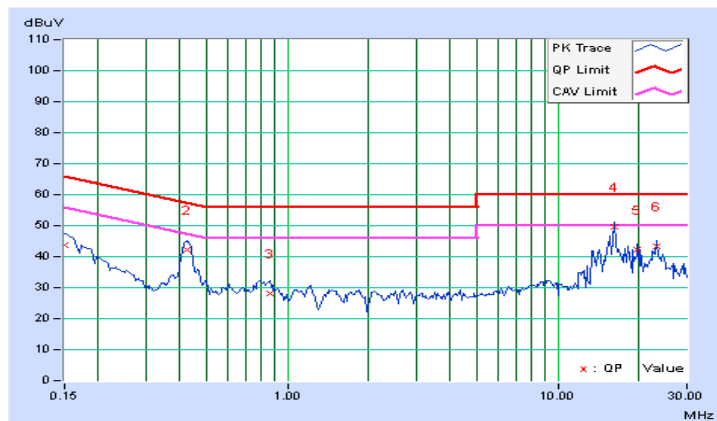

Phase	Neutral (N)	Detector Function	Quasi-Peak (QP) / Average (AV)
-------	-------------	-------------------	--------------------------------

Phase Of Power : Neutral (N)										
No	Frequency (MHz)	Correction Factor (dB)	Reading Value (dBuV)		Emission Level (dBuV)		Limit (dBuV)		Margin (dB)	
			Q.P.	AV.	Q.P.	AV.	Q.P.	AV.	Q.P.	AV.
1	0.15781	10.23	33.55	25.33	43.78	35.56	65.58	55.58	-21.79	-20.01
2	0.42734	10.22	33.18	27.34	43.40	37.56	57.30	47.30	-13.91	-9.75
3	13.35938	10.70	29.84	27.19	40.54	37.89	60.00	50.00	-19.46	-12.11
4	16.23047	10.83	38.49	35.93	49.32	46.76	60.00	50.00	-10.68	-3.24
5	19.70703	10.94	30.86	27.79	41.80	38.73	60.00	50.00	-18.20	-11.27
6	23.12891	10.98	31.96	30.16	42.94	41.14	60.00	50.00	-17.06	-8.86

Remarks:

1. Q.P. and AV. are abbreviations of quasi-peak and average individually.
2. The emission levels of other frequencies were very low against the limit.
3. Margin value = Emission level – Limit value
4. Correction factor = Insertion loss + Cable loss
5. Emission Level = Correction Factor + Reading Value

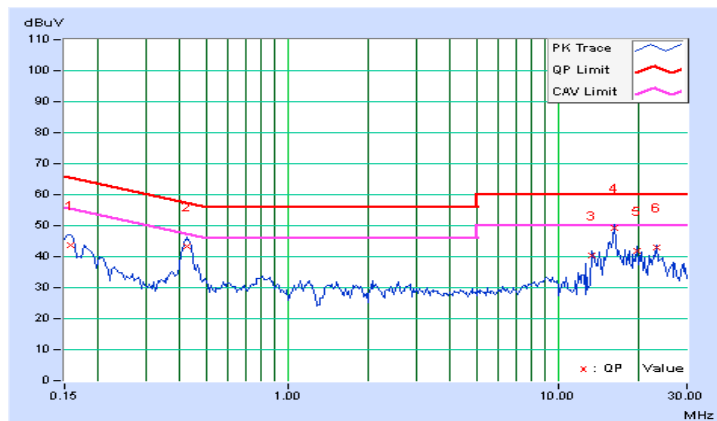

4.2.9 Test Results (Mode 3)

Phase	Line (L)	Detector Function	Quasi-Peak (QP) / Average (AV)
-------	----------	-------------------	--------------------------------

Phase Of Power : Line (L)										
No	Frequency (MHz)	Correction Factor (dB)	Reading Value (dBuV)		Emission Level (dBuV)		Limit (dBuV)		Margin (dB)	
			Q.P.	AV.	Q.P.	AV.	Q.P.	AV.	Q.P.	AV.
1	0.15781	10.32	29.28	18.59	39.60	28.91	65.58	55.58	-25.98	-26.67
2	0.19297	10.29	21.68	9.17	31.97	19.46	63.91	53.91	-31.94	-34.45
3	0.43906	10.30	25.67	22.41	35.97	32.71	57.08	47.08	-21.11	-14.37
4	0.95469	10.24	13.10	7.62	23.34	17.86	56.00	46.00	-32.66	-28.14
5	14.76172	10.78	23.11	14.74	33.89	25.52	60.00	50.00	-26.11	-24.48
6	18.24219	10.89	27.38	23.51	38.27	34.40	60.00	50.00	-21.73	-15.60

Remarks:

1. Q.P. and AV. are abbreviations of quasi-peak and average individually.
2. The emission levels of other frequencies were very low against the limit.
3. Margin value = Emission level – Limit value
4. Correction factor = Insertion loss + Cable loss
5. Emission Level = Correction Factor + Reading Value

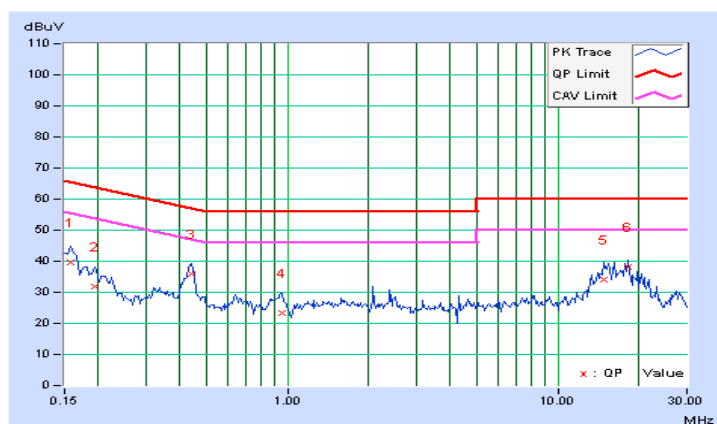

Phase	Neutral (N)	Detector Function	Quasi-Peak (QP) / Average (AV)
-------	-------------	-------------------	--------------------------------

Phase Of Power : Neutral (N)										
No	Frequency (MHz)	Correction Factor (dB)	Reading Value (dBuV)		Emission Level (dBuV)		Limit (dBuV)		Margin (dB)	
			Q.P.	AV.	Q.P.	AV.	Q.P.	AV.	Q.P.	AV.
1	0.15000	10.30	31.81	24.84	42.11	35.14	66.00	56.00	-23.89	-20.86
2	0.17734	10.28	22.48	14.87	32.76	25.15	64.61	54.61	-31.85	-29.46
3	0.43906	10.28	21.15	14.25	31.43	24.53	57.08	47.08	-25.65	-22.55
4	2.08203	10.27	16.96	3.05	27.23	13.32	56.00	46.00	-28.77	-32.68
5	4.25000	10.44	13.36	0.29	23.80	10.73	56.00	46.00	-32.20	-35.27
6	18.24219	10.92	26.43	23.05	37.35	33.97	60.00	50.00	-22.65	-16.03

Remarks:

1. Q.P. and AV. are abbreviations of quasi-peak and average individually.
2. The emission levels of other frequencies were very low against the limit.
3. Margin value = Emission level – Limit value
4. Correction factor = Insertion loss + Cable loss
5. Emission Level = Correction Factor + Reading Value

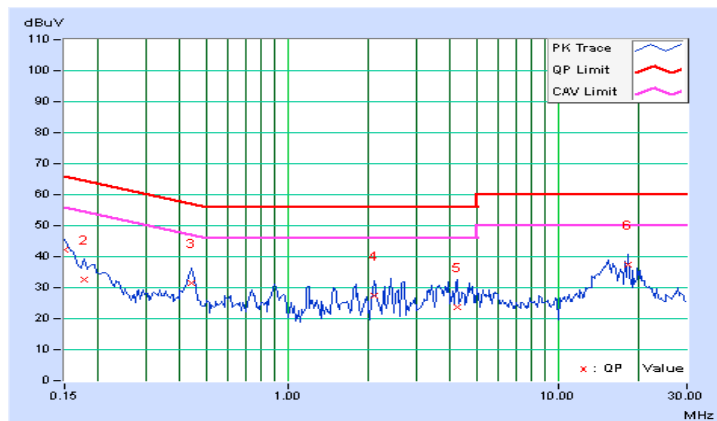

4.3 6dB Bandwidth Measurement

4.3.1 Limits of 6dB Bandwidth Measurement

The minimum of 6dB Bandwidth Measurement is 0.5 MHz.

4.3.2 Test Setup

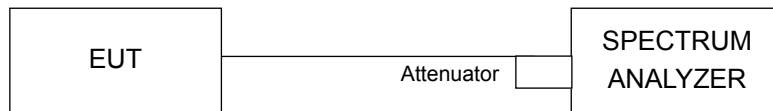

4.3.3 Test Instruments

Refer to section 4.1.2 to get information of above instrument.

4.3.4 Test Procedure

- a. Set resolution bandwidth (RBW) = 100kHz
- b. Set the video bandwidth (VBW) $\geq 3 \times$ RBW, Detector = Peak.
- c. Trace mode = max hold.
- d. Sweep = auto couple.
- e. Measure the maximum width of the emission that is constrained by the frequencies associated with the two amplitude points (upper and lower) that are attenuated by 6 dB relative to the maximum level measured in the fundamental emission

4.3.5 Deviation from Test Standard

No deviation.

4.3.6 EUT Operating Conditions

The software provided by client to enable the EUT under transmission condition continuously at lowest, middle and highest channel frequencies individually.

4.3.7 Test Result

Channel	Frequency (MHz)	6dB Bandwidth (MHz)		Minimum Limit (MHz)	Pass / Fail
		Chain 0	Chain 1		
802.11b					
1	2412	7.15	7.14	0.5	Pass
6	2437	7.18	7.57	0.5	Pass
11	2462	7.17	7.17	0.5	Pass
802.11g					
1	2412	16.34	16.35	0.5	Pass
6	2437	16.31	16.36	0.5	Pass
11	2462	16.34	16.12	0.5	Pass
802.11n (HT20)					
1	2412	17.24	16.89	0.5	Pass
6	2437	17.25	17.20	0.5	Pass
11	2462	17.56	16.98	0.5	Pass

Spectrum Plot of Worst Value

802.11b / Chain1 - CH1

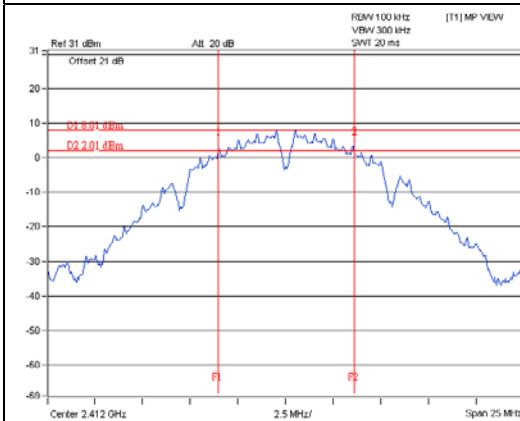

802.11g / Chain1 - CH1

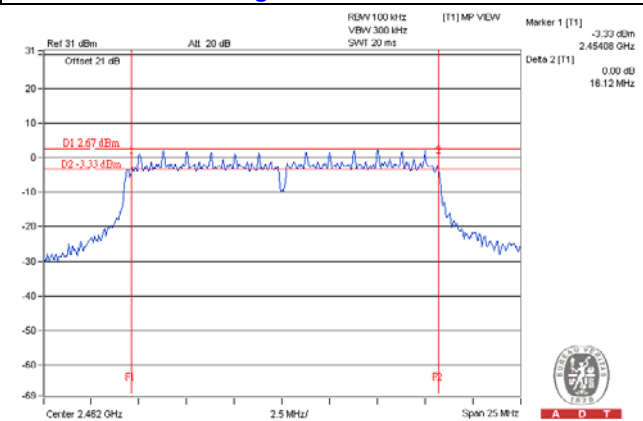

802.11n (HT20) / Chain1 - CH1

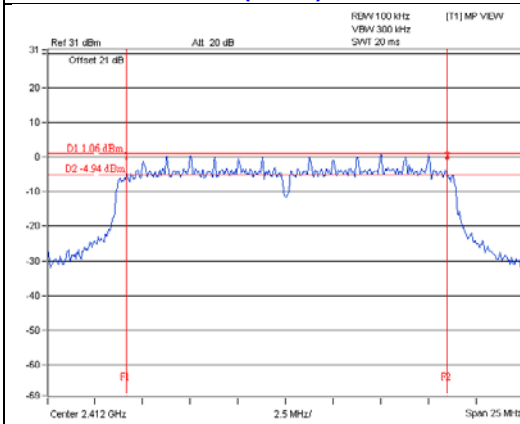

4.4 Conducted Output Power Measurement

4.4.1 Limits of Conducted Output Power Measurement

For systems using digital modulation in the 2400–2483.5 MHz bands: 1 Watt (30dBm)

Per KDB 662911 D01 Multiple Transmitter Output v02r01 Method of conducted output power measurement on IEEE 802.11 devices,

Array Gain = 0 dB (i.e., no array gain) for $NANT \leq 4$;

Array Gain = 0 dB (i.e., no array gain) for channel widths ≥ 40 MHz for any NANT;

Array Gain = $5 \log(NANT/NSS)$ dB or 3 dB, whichever is less for 20-MHz channel widths with $NANT \geq 5$.

For power measurements on all other devices: Array Gain = $10 \log(NANT/NSS)$ dB.

4.4.2 Test Setup

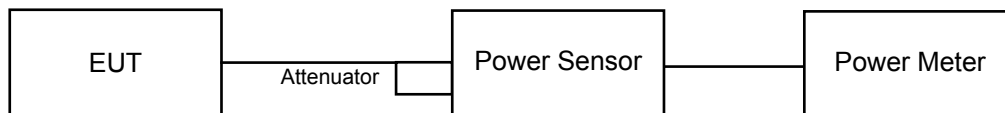

4.4.3 Test Instruments

Refer to section 4.1.2 to get information of above instrument.

4.4.4 Test Procedures

A peak / average power sensor was used on the output port of the EUT. A power meter was used to read the response of the peak / average power sensor. Record the power level.

4.4.5 Deviation from Test Standard

No deviation.

4.4.6 EUT Operating Conditions

Same as Item 4.3.6.

4.4.7 Test Results

FOR PEAK POWER

Chan.	Chan. Freq. (MHz)	Peak Power (dBm)		Total Power (mW)	Total Power (dBm)	Limit (dBm)	Pass / Fail
		Chain 0	Chain 1				
802.11b							
1	2412	20.75	20.68	235.8	23.73	30	Pass
6	2437	20.99	21.81	277.308	24.43	30	Pass
11	2462	20.28	21.12	236.08	23.73	30	Pass
802.11g							
1	2412	20.46	20.46	222.346	23.47	30	Pass
6	2437	21.84	22.55	332.644	25.22	30	Pass
11	2462	20.40	19.67	202.331	23.06	30	Pass
802.11n (HT20)							
1	2412	18.45	18.13	134.997	21.30	30	Pass
6	2437	25.87	22.45	562.159	27.50	30	Pass
11	2462	17.99	18.48	133.42	21.25	30	Pass

FOR AVERAGE POWER

Chan.	Chan. Freq. (MHz)	Average Power (dBm)		Total Power (mW)	Total Power (dBm)
		Chain 0	Chain 1		
802.11b					
1	2412	17.95	17.85	123.327	20.91
6	2437	19.24	19.58	174.728	22.42
11	2462	18.01	18.75	138.230	21.41
802.11g					
1	2412	15.20	15.20	66.226	18.21
6	2437	19.78	20.24	200.742	23.03
11	2462	15.40	14.30	61.589	17.90
802.11n (HT20)					
1	2412	12.52	12.61	36.104	15.58
6	2437	19.26	19.85	180.938	22.58
11	2462	12.05	13.24	37.118	15.70

4.5 Power Spectral Density Measurement

4.5.1 Limits of Power Spectral Density Measurement

The Maximum of Power Spectral Density Measurement is 8dBm.

4.5.2 Test Setup

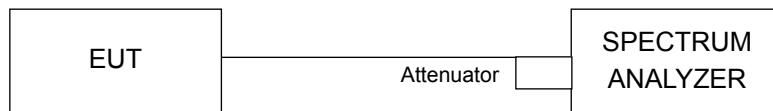

4.5.3 Test Instruments

Refer to section 4.1.2 to get information of above instrument.

4.5.4 Test Procedure

- a. Set analyzer center frequency to DTS channel center frequency.
- b. Set the span to 1.5 times the DTS bandwidth.
- c. Set the RBW to: $3 \text{ kHz} \leq \text{RBW} \leq 100 \text{ kHz}$.
- d. Set the VBW $\geq 3 \times \text{RBW}$.
- e. Detector = peak.
- f. Sweep time = auto couple.
- g. Trace mode = max hold.
- h. Allow trace to fully stabilize.
- i. Use the peak marker function to determine the maximum amplitude level within the RBW.

4.5.5 Deviation from Test Standard

No deviation.

4.5.6 EUT Operating Condition

Same as Item 4.3.6

4.5.7 Test Results

TX chain	Channel	Freq. (MHz)	PSD (dBm/3kHz)	10 log (N=2) dB	Total PSD (dBm/3kHz)	Limit (dBm/3kHz)	Pass /Fail
802.11b							
0	1	2412	-7.84	3.01	-4.83	8	Pass
	6	2437	-5.23	3.01	-2.22	8	Pass
	11	2462	-7.61	3.01	-4.60	8	Pass
1	1	2412	-6.92	3.01	-3.91	8	Pass
	6	2437	-7.51	3.01	-4.50	8	Pass
	11	2462	-8.35	3.01	-5.34	8	Pass
802.11g							
0	1	2412	-12.94	3.01	-9.93	8	Pass
	6	2437	-8.33	3.01	-5.32	8	Pass
	11	2462	-13.44	3.01	-10.43	8	Pass
1	1	2412	-14.68	3.01	-11.67	8	Pass
	6	2437	-9.42	3.01	-6.41	8	Pass
	11	2462	-15.29	3.01	-12.28	8	Pass
802.11n (HT20)							
0	1	2412	-15.34	3.01	-12.33	8	Pass
	6	2437	-8.43	3.01	-5.42	8	Pass
	11	2462	-15.10	3.01	-12.09	8	Pass
1	1	2412	-15.72	3.01	-12.71	8	Pass
	6	2437	-9.95	3.01	-6.94	8	Pass
	11	2462	-16.51	3.01	-13.50	8	Pass

Note: Directional gain = $10 \log[(10^{G1/20} + 10^{G2/20})^2 / 2] = 3.97\text{dBi} < 6\text{dBi}$, so the power density limit shall not be reduced.

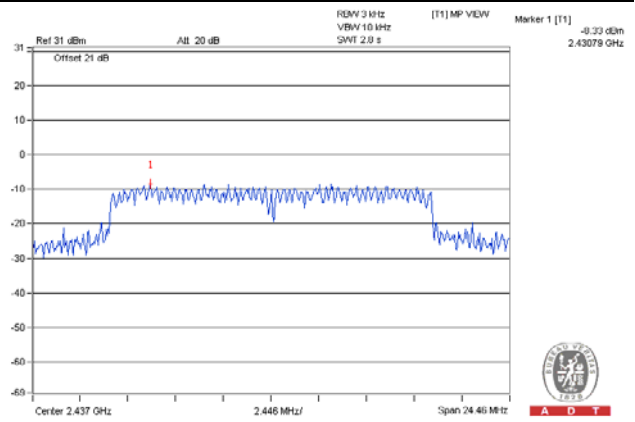
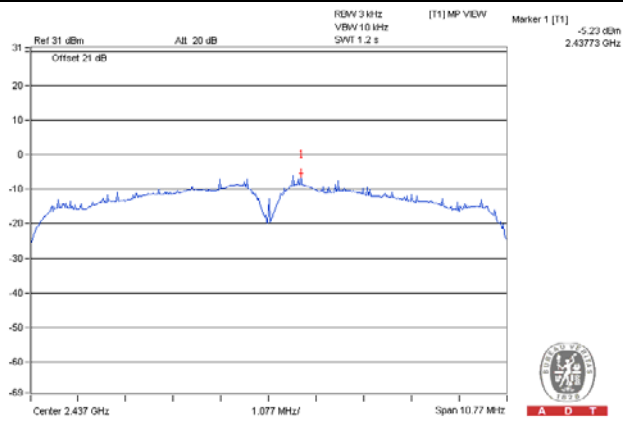
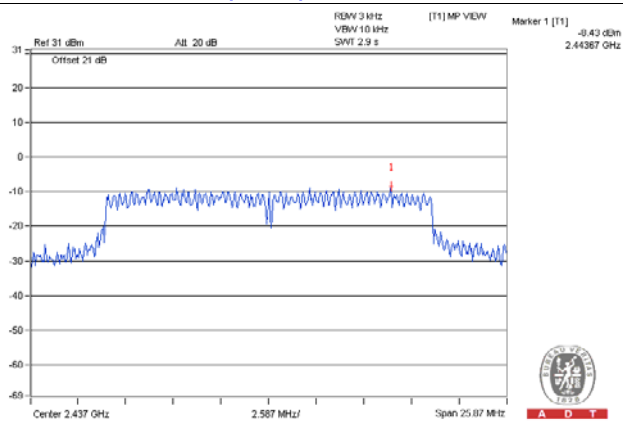
Spectrum Plot of Worst Value**802.11b / Chain0 - CH6****802.11g / Chain0 - CH6****802.11n (HT20) / Chain0 - CH6**

4.6 Conducted Out of Band Emission Measurement

4.6.1 Limits of Conducted Out of Band Emission Measurement

Below 20dBc of the highest emission level of operating band (in 100kHz Resolution Bandwidth).

4.6.2 Test Setup

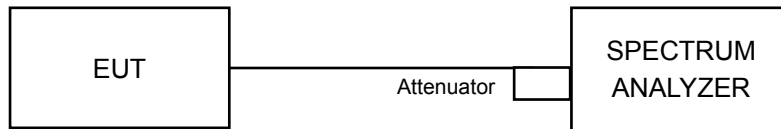

4.6.3 Test Instruments

Refer to section 4.1.2 to get information of above instrument.

4.6.4 Test Procedure

MEASUREMENT PROCEDURE REF

1. Set the RBW = 100 kHz.
2. Set the VBW \geq 300 kHz.
3. Detector = peak.
4. Sweep time = auto couple.
5. Trace mode = max hold.
6. Allow trace to fully stabilize.
7. Use the peak marker function to determine the maximum power level in any 100 kHz band segment within the fundamental EBW.

MEASUREMENT PROCEDURE OOB

1. Set RBW = 100 kHz.
2. Set VBW \geq 300 kHz.
3. Detector = peak.
4. Sweep = auto couple.
5. Trace Mode = max hold.
6. Allow trace to fully stabilize.
7. Use the peak marker function to determine the maximum amplitude level.

4.6.5 Deviation from Test Standard

No deviation.

4.6.6 EUT Operating Condition

Same as Item 4.3.6

4.6.7 Test Results

The spectrum plots are attached on the following pages. D1 line indicates the highest level, and D2 line indicates the 20dB offset below D1. It shows compliance with the requirement.

802.11b – Chain 0

CH 1

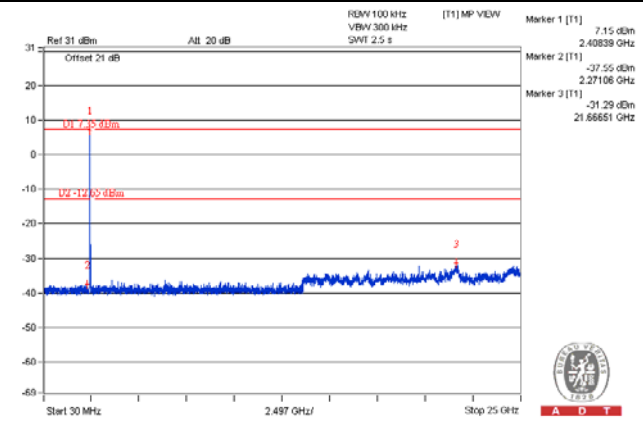
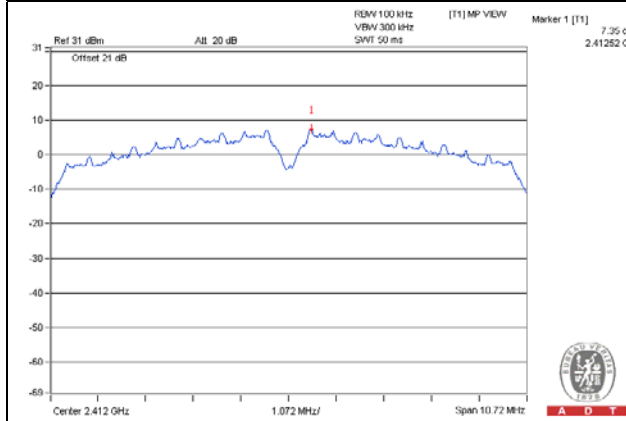

CH 6

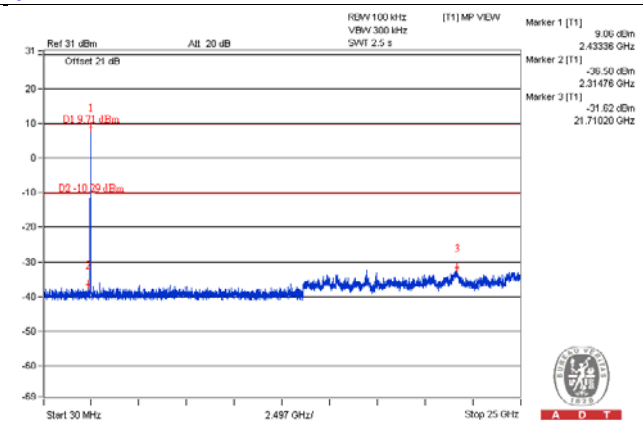
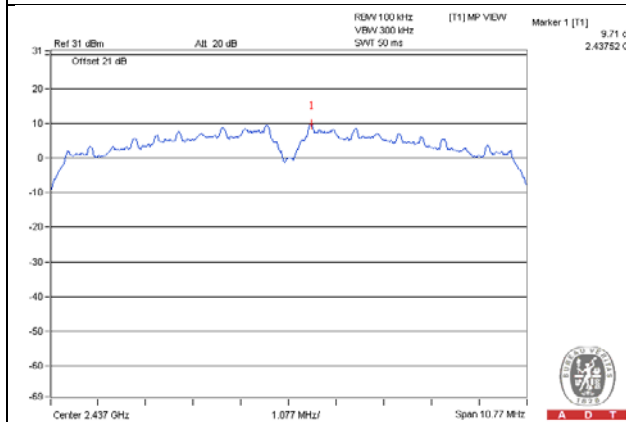

CH 11

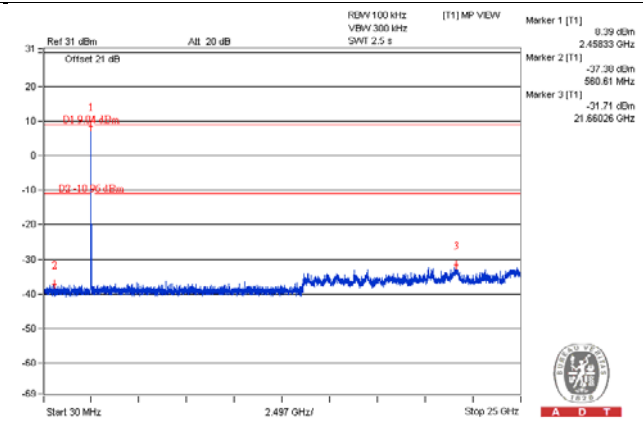
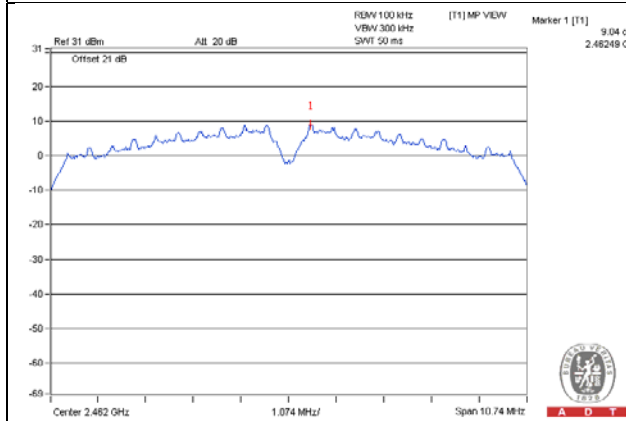

CH 1 Band edge

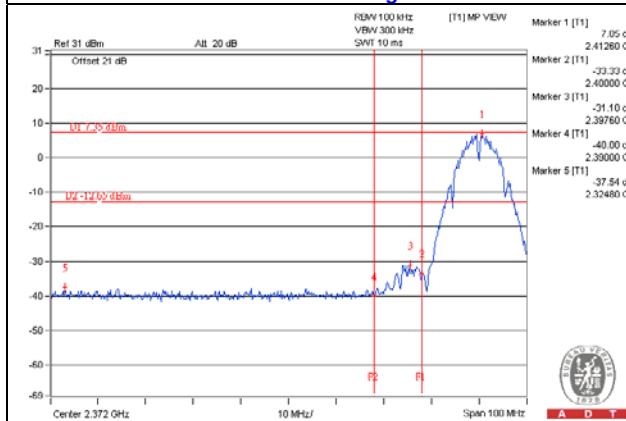

CH 11 Band edge

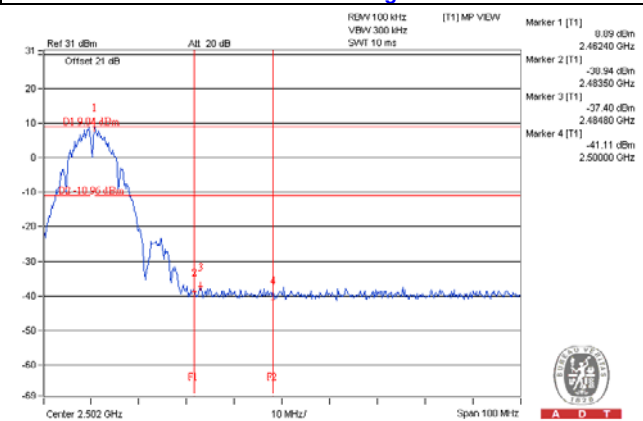

Chain 1

CH 1

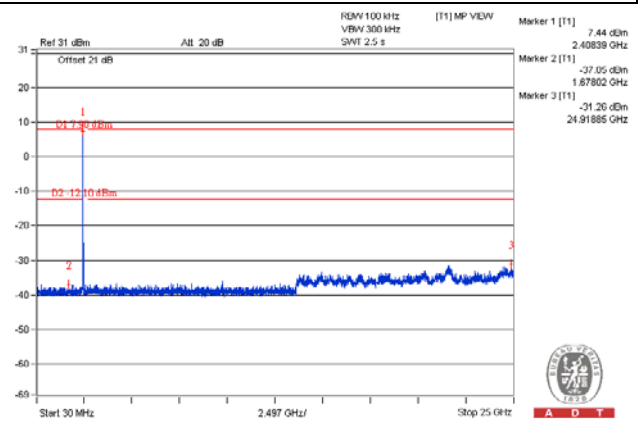
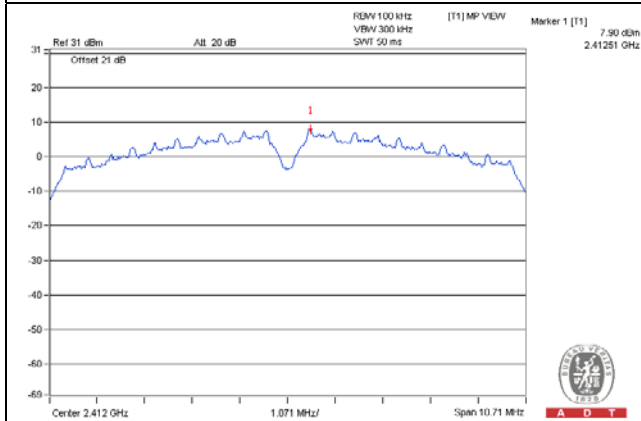

CH 6

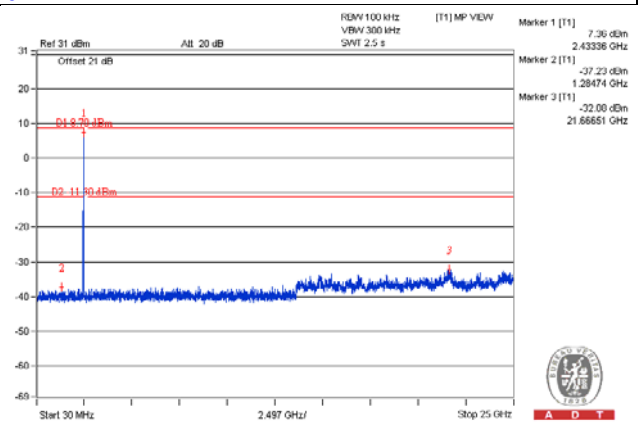
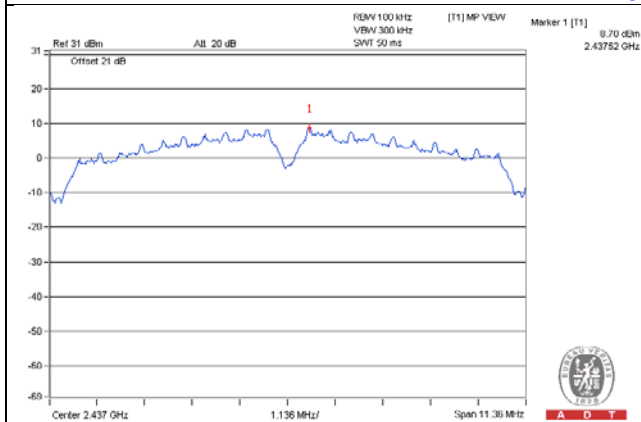

CH 11

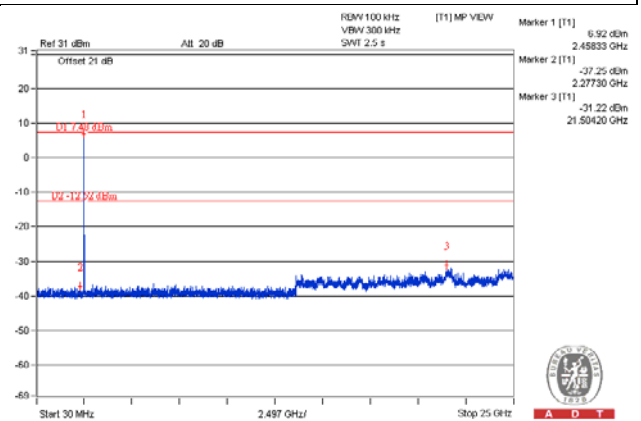
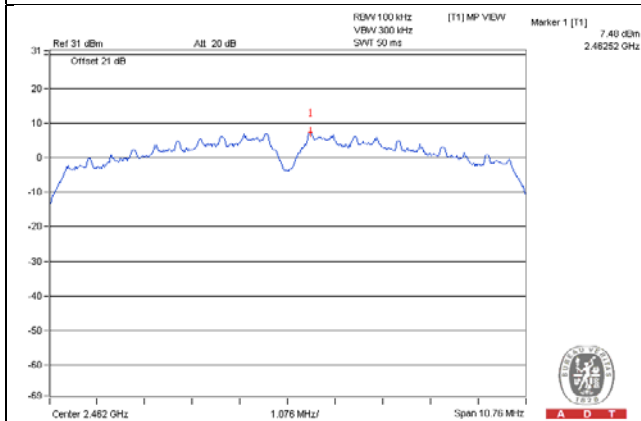

CH 1 Band edge

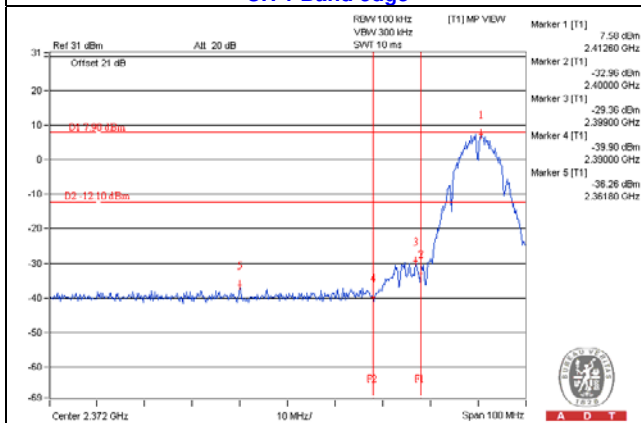

CH 11 Band edge

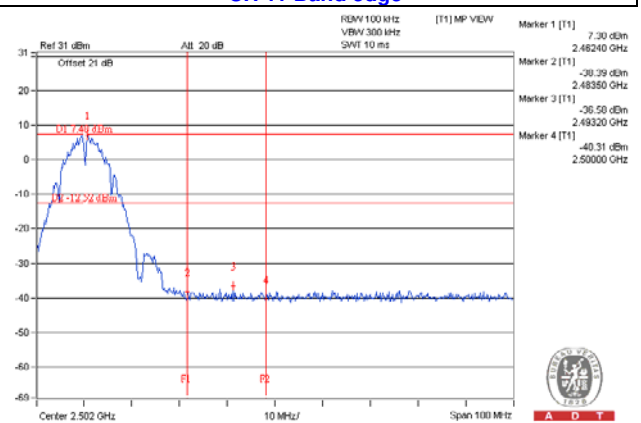

802.11g – Chain 0

CH 1

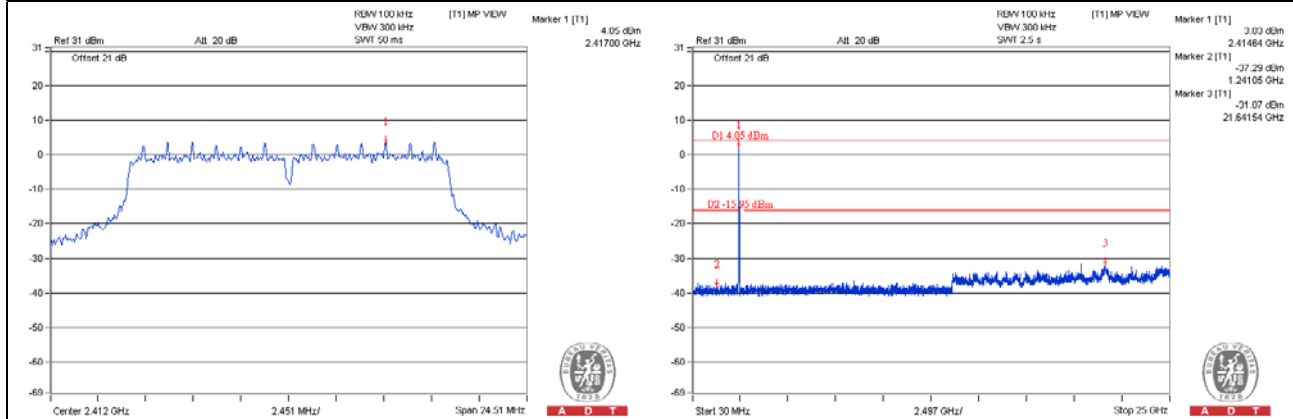

CH 6

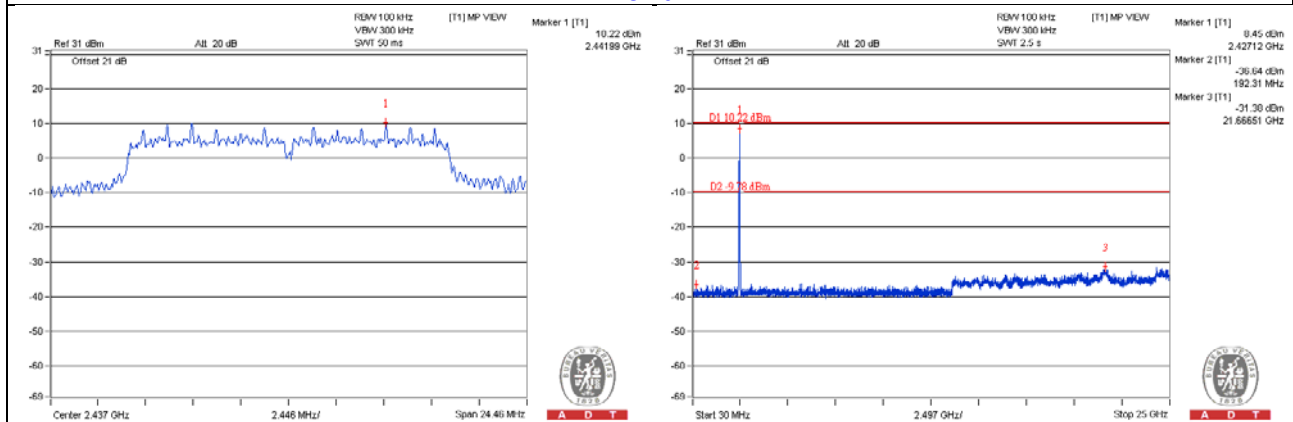

CH 11

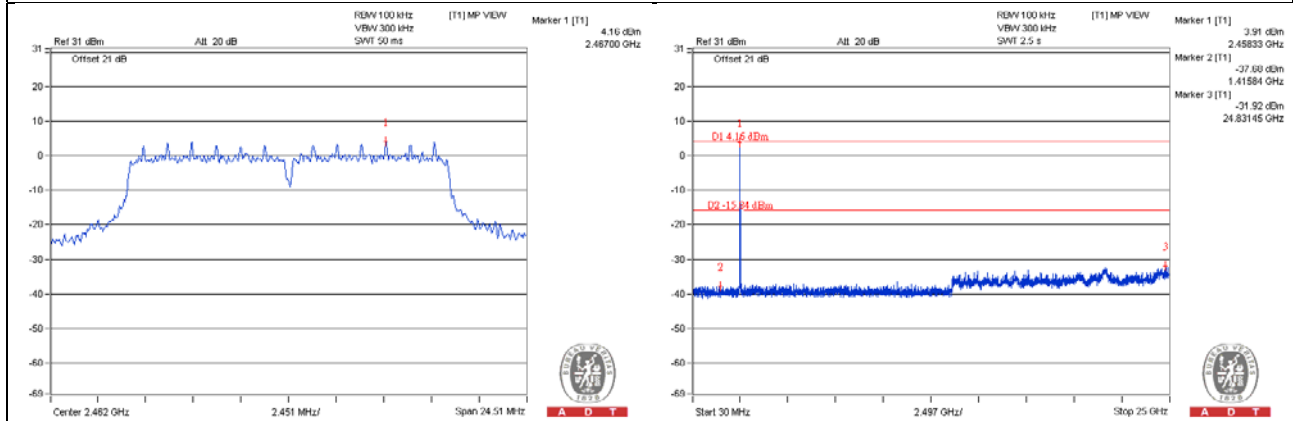

CH 1 Band edge

CH 11 Band edge

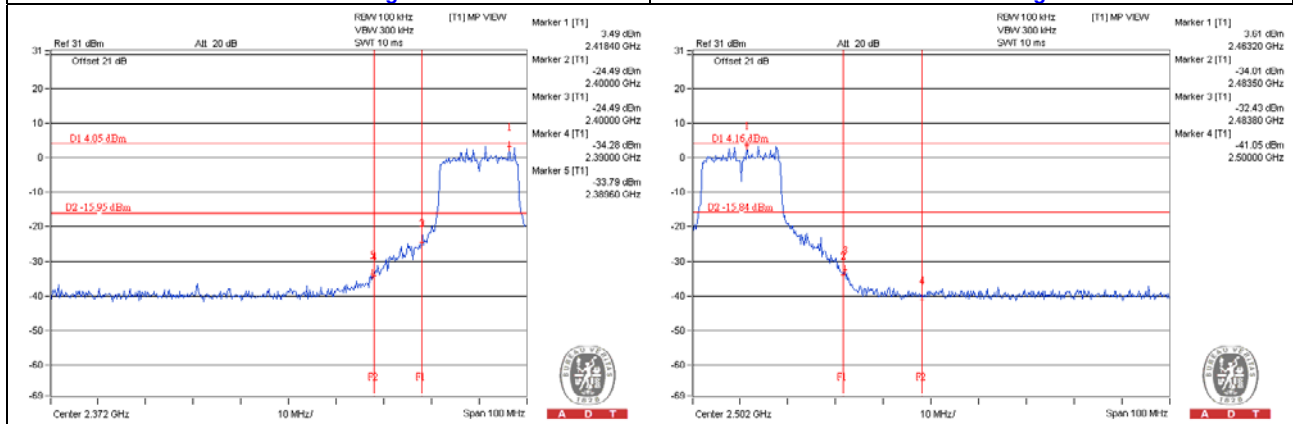

Chain 1

CH 1

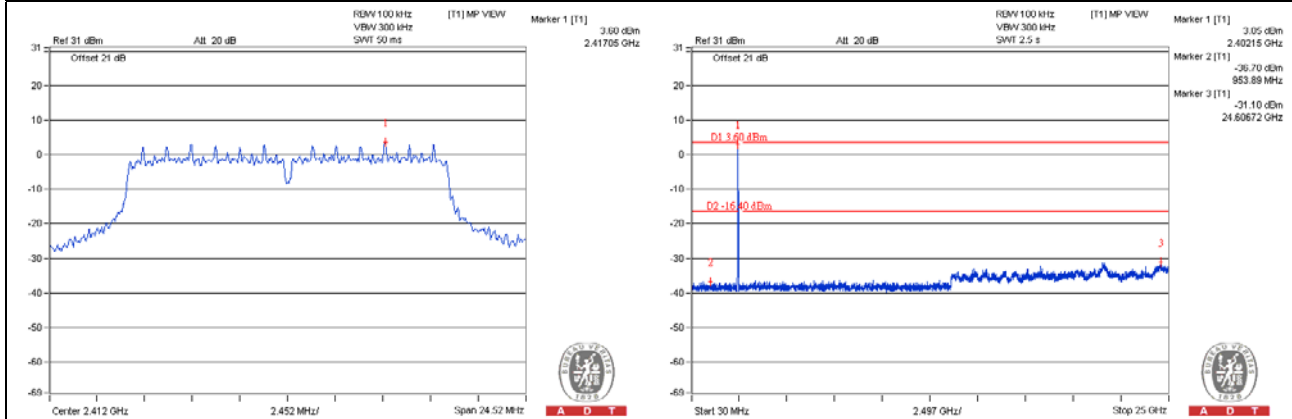

CH 6

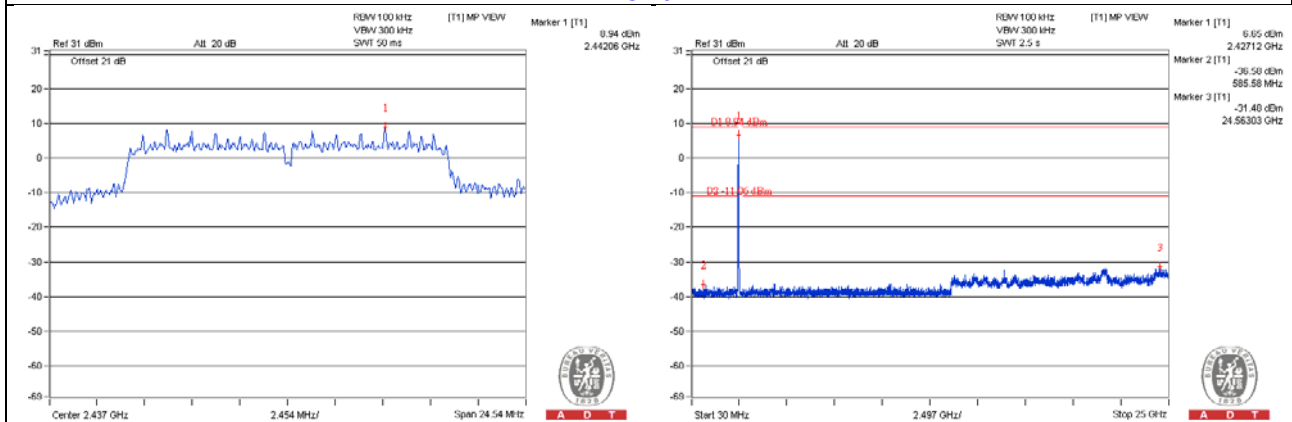

CH 11

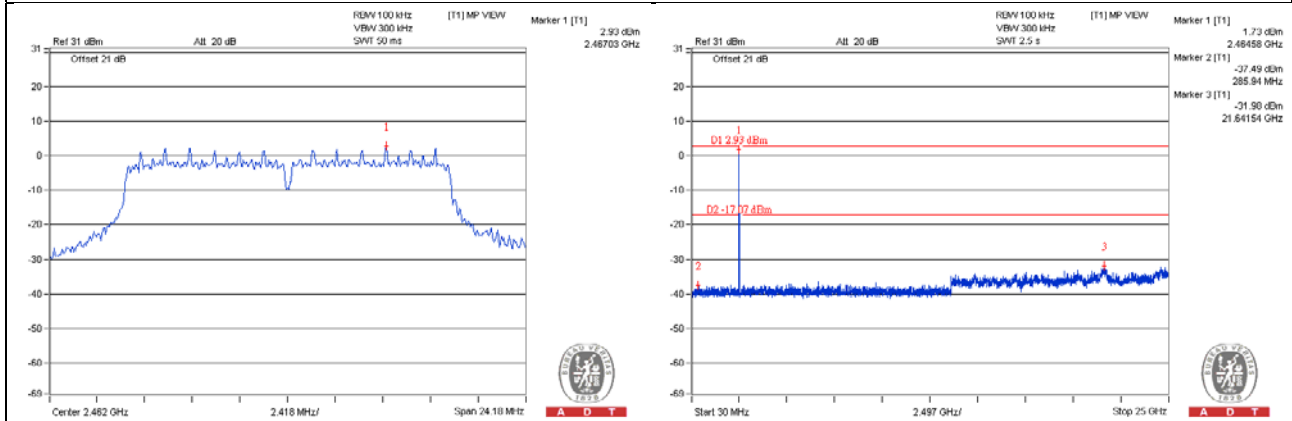

CH 1 Band edge

CH 11 Band edge

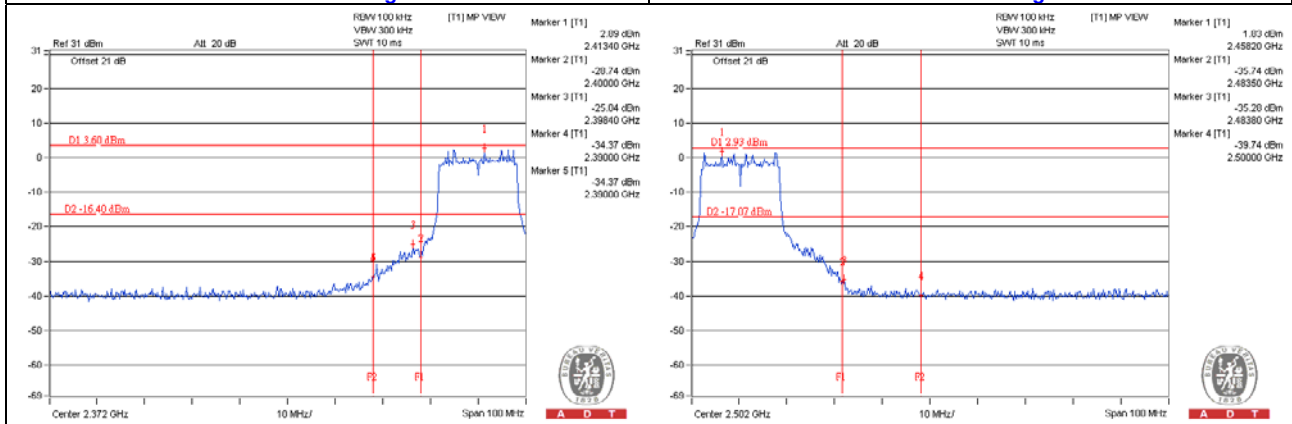

802.11n (HT20) - Chain 0

CH 1

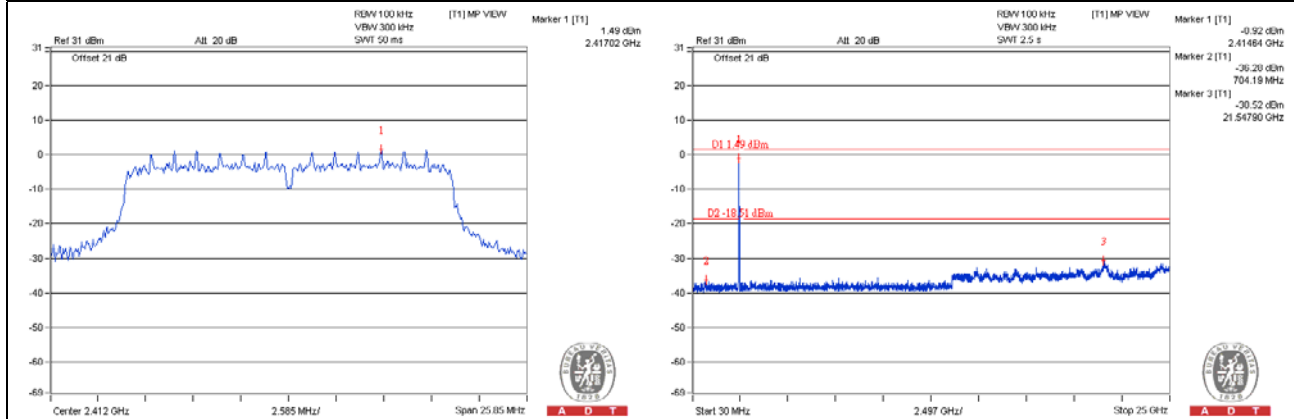

CH 6

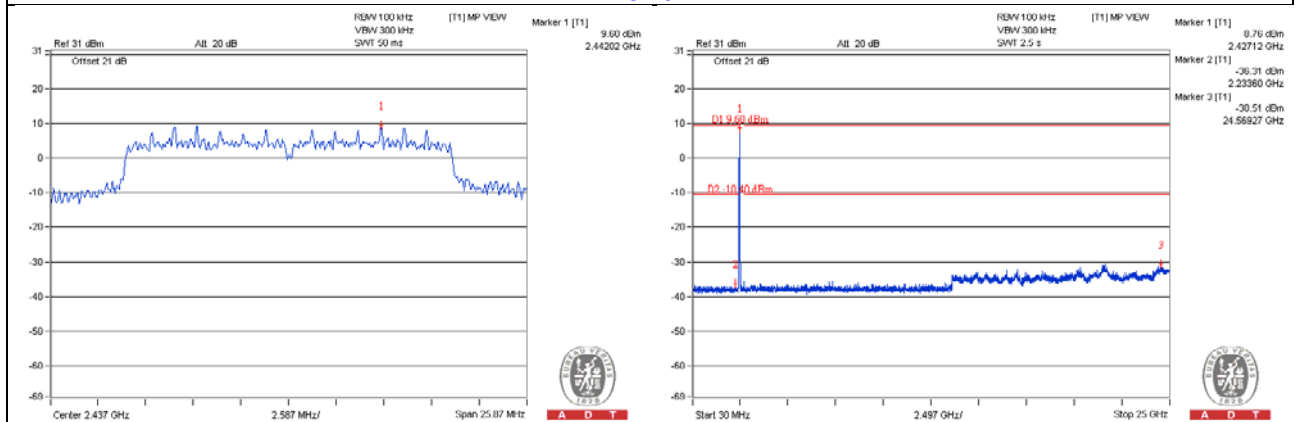

CH 11

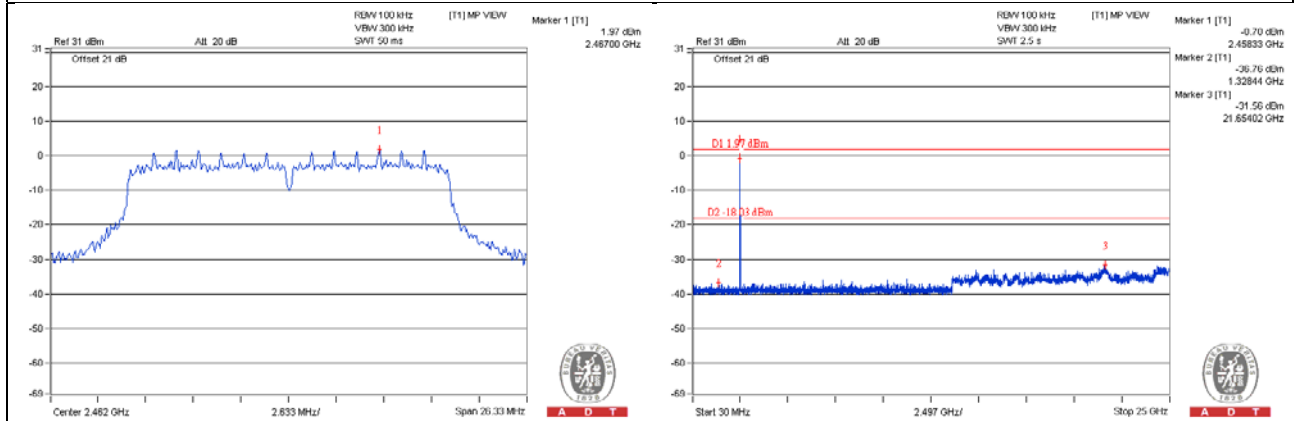

CH 1 Band edge

CH 11 Band edge

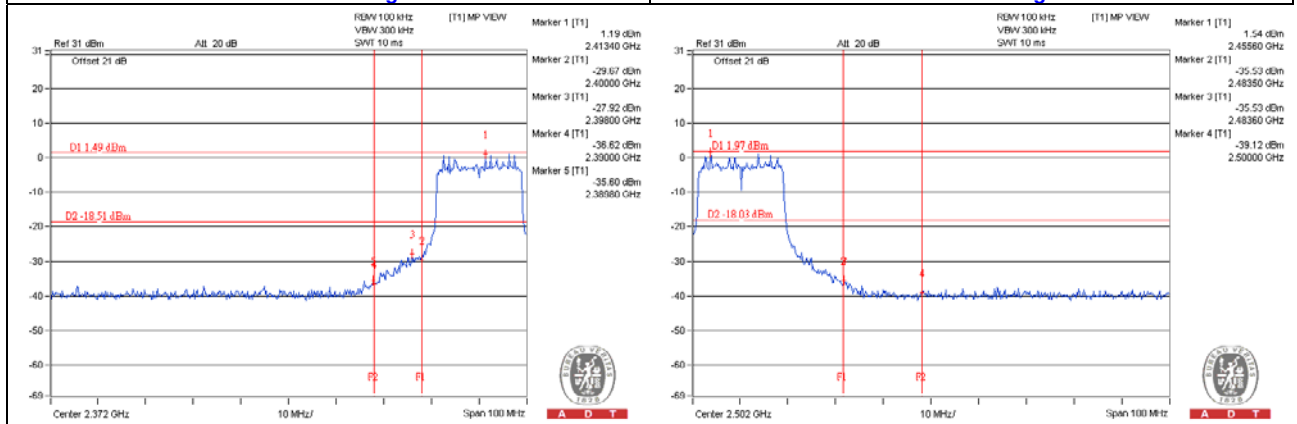

Chain 1

CH 1

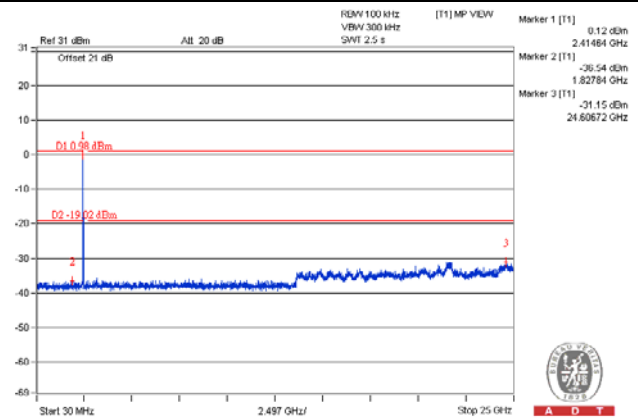
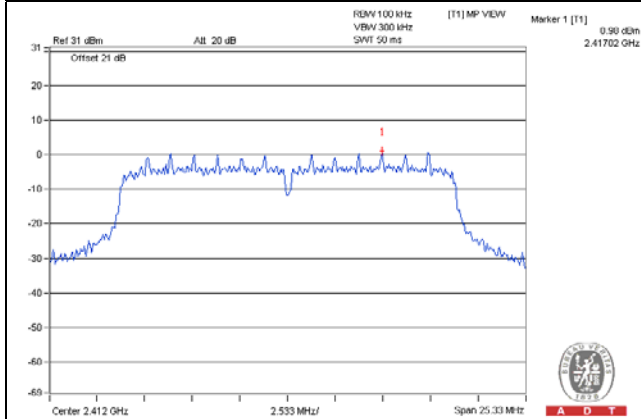

CH 6

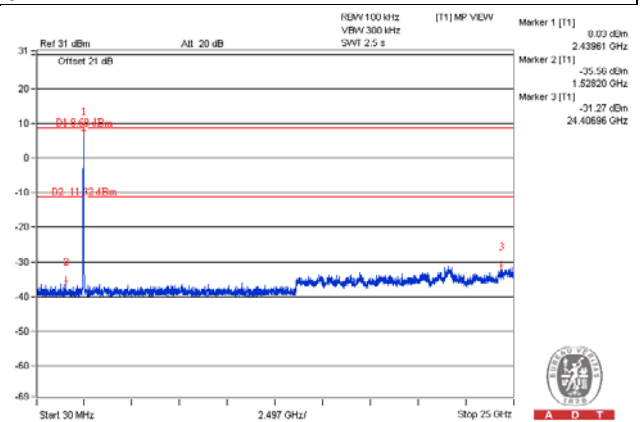
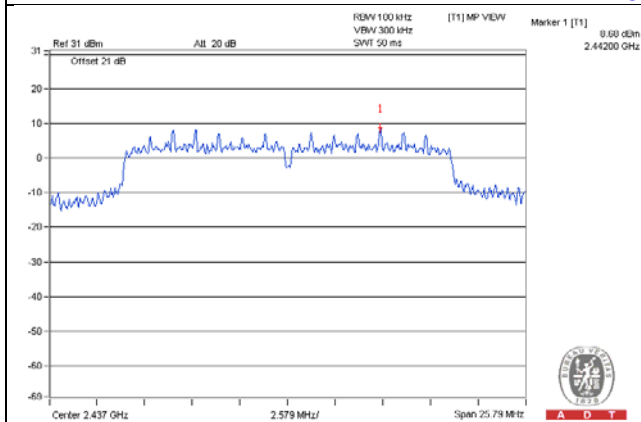

CH 11

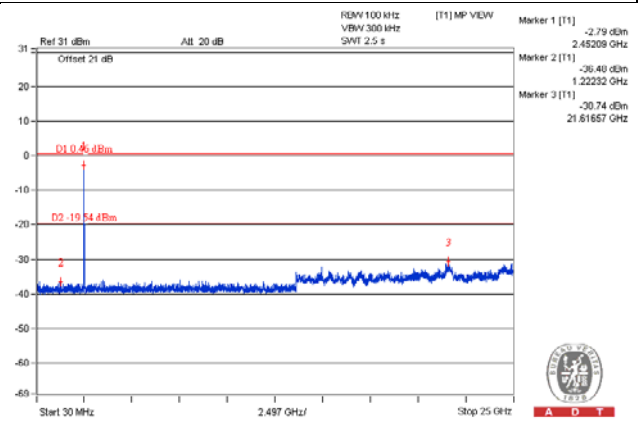
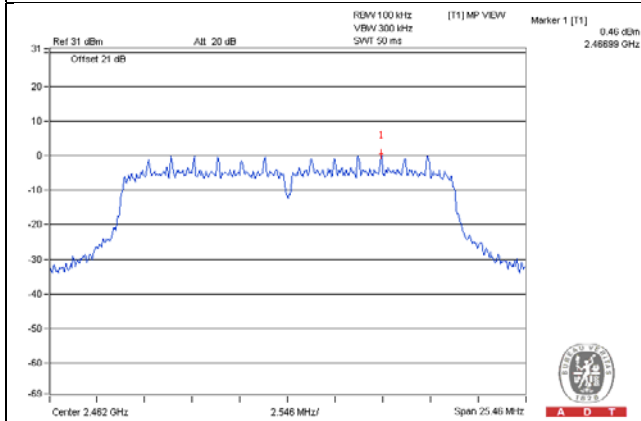

CH 1 Band edge

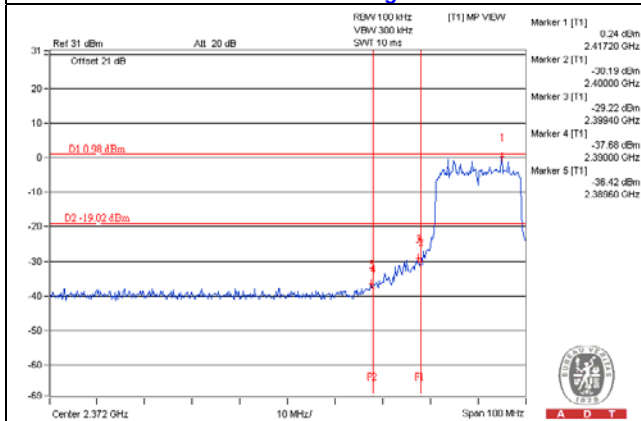

CH 11 Band edge

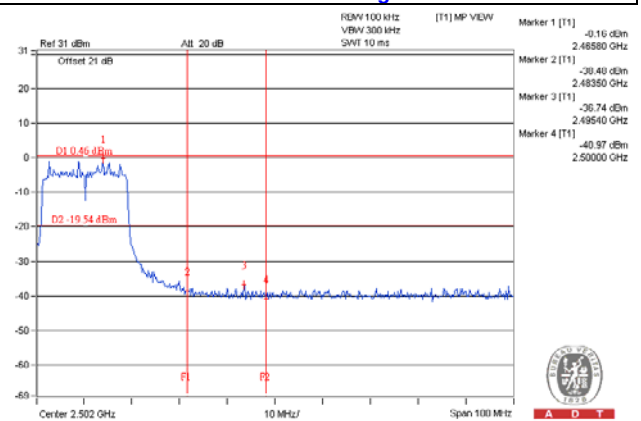

5 Pictures of Test Arrangements

Please refer to the attached file (Test Setup Photo).

Appendix – Information on the Testing Laboratories

We, Bureau Veritas Consumer Products Services (H.K.) Ltd., Taoyuan Branch, were founded in 1988 to provide our best service in EMC, Radio, Telecom and Safety consultation. Our laboratories are accredited and approved according to ISO/IEC 17025.

If you have any comments, please feel free to contact us at the following:

Linko EMC/RF Lab

Tel: 886-2-26052180

Fax: 886-2-26051924

Hsin Chu EMC/RF/Telecom Lab

Tel: 886-3-6668565

Fax: 886-3-6668323

Hwa Ya EMC/RF/Safety Lab

Tel: 886-3-3183232

Fax: 886-3-3270892

Email: service.adt@tw.bureauveritas.com

Web Site: www.bureauveritas-adt.com

The address and road map of all our labs can be found in our web site also.

--- END ---