

FCC Test Report

Report No.: RF150624E06F-1

FCC ID: PY315300320

Test Model: WAC720

Received Date: Oct. 12, 2015

Test Date: Oct. 28 to Nov. 16, 2015

Issued Date: Dec. 01, 2015

Applicant: NETGEAR, Inc.

Address: 350 East Plumeria Drive San Jose, CA 95134

Issued By: Bureau Veritas Consumer Products Services (H.K.) Ltd., Taoyuan Branch
Hsin Chu Laboratory

Lab Address: No. 81-1, Lu Liao Keng, 9th Ling, Wu Lung Tsuen, Chiung Lin Hsiang, Hsin
Chu Hsien 307, Taiwan R.O.C.

Test Location (1): No. 81-1, Lu Liao Keng, 9th Ling, Wu Lung Tsuen, Chiung Lin Hsiang, Hsin
Chu Hsien 307, Taiwan R.O.C.

Test Location (2): No. 49, Ln. 206, Wende Rd., Shangshan Tsuen, Chiung Lin Hsiang, Hsin
Chu Hsien 307, Taiwan R.O.C.

Test Location (3): E-2, No.1, Li Hsin 1st Road, Hsinchu Science Park, Hsinchu City 300,
Taiwan R.O.C.



This report is for your exclusive use. Any copying or replication of this report to or for any other person or entity, or use of our name or trademark, is permitted only with our prior written permission. This report sets forth our findings solely with respect to the test samples identified herein. The results set forth in this report are not indicative or representative of the quality or characteristics of the lot from which a test sample was taken or any similar or identical product unless specifically and expressly noted. Our report includes all of the tests requested by you and the results thereof based upon the information that you provided to us. You have 60 days from date of issuance of this report to notify us of any material error or omission caused by our negligence, provided, however, that such notice shall be in writing and shall specifically address the issue you wish to raise. A failure to raise such issue within the prescribed time shall constitute your unqualified acceptance of the completeness of this report, the tests conducted and the correctness of the report contents. Unless specific mention, the uncertainty of measurement has been explicitly taken into account to declare the compliance or non-compliance to the specification. The report must not be used by the client to claim product certification, approval, or endorsement by TAF or any government agencies.

Table of Contents

Release Control Record	4
1 Certificate of Conformity	5
2 Summary of Test Results	6
2.1 Measurement Uncertainty	6
2.2 Modification Record	6
3 General Information	7
3.1 General Description of EUT (DFS Band)	7
3.2 Description of Test Modes	10
3.2.1 Test Mode Applicability and Tested Channel Detail	11
3.3 Duty Cycle of Test Signal	13
3.4 Description of Support Units	14
3.4.1 Configuration of System under Test	15
3.5 General Description of Applied Standard	17
4 Test Types and Results	18
4.1 Radiated Emission and Bandedge Measurement	18
4.1.1 Limits of Radiated Emission and Bandedge Measurement	18
4.1.2 Test Instruments	19
4.1.3 Test Procedure	21
4.1.4 Deviation from Test Standard	21
4.1.5 Test Setup	22
4.1.6 EUT Operating Condition	22
4.1.7 Test Results (Mode 1)	23
4.1.8 Test Results (Mode 2)	44
4.2 Conducted Emission Measurement	65
4.2.1 Limits of Conducted Emission Measurement	65
4.2.2 Test Instruments	65
4.2.3 Test Procedure	66
4.2.4 Deviation from Test Standard	66
4.2.5 Test Setup	66
4.2.6 EUT Operating Condition	66
4.2.7 Test Results (Mode 2)	67
4.2.8 Test Results (Mode 3)	69
4.2.9 Test Results (Mode 4)	71
4.3 Transmit Power Measurement	73
4.3.1 Limits of Transmit Power Measurement	73
4.3.2 Test Setup	73
4.3.3 Test Instruments	73
4.3.4 Test Procedure	74
4.3.5 Deviation from Test Standard	74
4.3.6 EUT Operating Condition	74
4.3.7 Test Result	75
4.4 Peak Power Spectral Density Measurement	83
4.4.1 Limits of Peak Power Spectral Density Measurement	83
4.4.2 Test Setup	83
4.4.3 Test Instruments	83
4.4.4 Test Procedure	83
4.4.5 Deviation from Test Standard	83
4.4.6 EUT Operating Condition	83
4.4.7 Test Results	84
4.5 Frequency Stability Measurement	86
4.5.1 Limits of Frequency Stability Measurement	86
4.5.2 Test Setup	86
4.5.3 Test Instruments	86



4.5.4 Test Procedure	86
4.5.5 Deviation from Test Standard	86
4.5.6 EUT Operating Condition	86
4.5.7 Test Results	87
5 Pictures of Test Arrangements.....	88
Appendix – Information on the Testing Laboratories	89



A D T

Release Control Record

Issue No.	Description	Date Issued
RF150624E06F-1	Original release.	Dec. 01, 2015

1 Certificate of Conformity

Product: ProSAFE Dual Band Wireless AC Access Point

Brand: NETGEAR

Test Model: WAC720

Sample Status: ENGINEERING SAMPLE

Applicant: NETGEAR, Inc.

Test Date: Oct. 28 to Nov. 16, 2015

Standard: 47 CFR FCC Part 15, Subpart E (Section 15.407)
ANSI C63.10: 2013

The above equipment has been tested by **Bureau Veritas Consumer Products Services (H.K.) Ltd., Taoyuan Branch**, and found compliance with the requirement of the above standards. The test record, data evaluation & Equipment Under Test (EUT) configurations represented herein are true and accurate accounts of the measurements of the sample's EMC characteristics under the conditions specified in this report.

Prepared by : Midoli Peng , **Date:** Dec. 01, 2015
Midoli Peng / Specialist

Approved by : May Chen , **Date:** Dec. 01, 2015
May Chen / Manager

2 Summary of Test Results

47 CFR FCC Part 15, Subpart E (SECTION 15.407)			
FCC Clause	Test Item	Result	Remarks
15.407(b)(6)	AC Power Conducted Emissions	PASS	Meet the requirement of limit. Minimum passing margin is -8.58dB at 0.31016MHz.
15.407(b)(1/2/3/4/6)	Radiated Emissions & Band Edge Measurement	PASS	Meet the requirement of limit. Minimum passing margin is -0.1dB at 5418.00MHz, 5458.00MHz, 5398.30MHz, 5418.00MHz, 5725.00MHz & 5470.00MHz
15.407(a)(1/2/3)	Max Average Transmit Power	PASS	Meet the requirement of limit.
15.407(a)(1/2/3)	Peak Power Spectral Density	PASS	Meet the requirement of limit.
15.407(g)	Frequency Stability	PASS	Meet the requirement of limit.
15.203	Antenna Requirement	Pass	Antenna connector is R-SMA and i-pex(MHF) not a standard connector.

NOTE: 1. This report is prepared for FCC class II permissive change. (Add DFS band: 5.26GHz ~ 5.32GHz, 5.5GHz ~ 5.7GHz).

2. The DFS report was recorded in another test report.

2.1 Measurement Uncertainty

Where relevant, the following measurement uncertainty levels have been estimated for tests performed on the EUT as specified in CISPR 16-4-2:

Measurement	Frequency	Expanded Uncertainty (k=2) (\pm)
Conducted Emissions at mains ports	150kHz ~ 30MHz	2.86 dB
Radiated Emissions up to 1 GHz	30MHz ~1GHz	5.43 dB
Radiated Emissions above 1 GHz	1GHz ~ 6GHz	3.65 dB
	6GHz ~ 18GHz	3.88 dB
	18GHz ~ 40GHz	4.11 dB

2.2 Modification Record

There were no modifications required for compliance.

3 General Information

3.1 General Description of EUT (DFS Band)

Product	ProSAFE Dual Band Wireless AC Access Point
Brand	NETGEAR
Test Model	WAC720
Status of EUT	ENGINEERING SAMPLE
Power Supply Rating	12Vdc from power adapter or 55Vdc from POE
Modulation Type	64QAM, 16QAM, QPSK, BPSK for OFDM 256QAM for OFDM in 11ac mode
Modulation Technology	OFDM
Transfer Rate	802.11a: up to 54Mbps 802.11n: up to 300Mbps 802.11ac: up to 866.7Mbps
Operating Frequency	5.26GHz ~ 5.32GHz, 5.5GHz ~ 5.7GHz
Number of Channel	15 for 802.11a, 802.11n (HT20), 802.11ac (VHT20) 7 for 802.11n (HT40), 802.11ac (VHT40) 3 for 802.11ac (VHT80)
Output Power	CDD Mode: 802.11a: 119.752mW 802.11ac (VHT20): 124.783mW 802.11ac (VHT40): 194.586mW 802.11ac (VHT80): 137.311mW Beamforming Mode: 802.11ac (VHT20): 124.783mW 802.11ac (VHT40): 123.774mW 802.11ac (VHT80): 124.154mW
Antenna Type	Refer to Note
Antenna Connector	Refer to Note
Accessory Device	Adapter x 1
Data Cable Supplied	NA

Note:

1. This report is prepared for FCC class II permissive change. The difference compared with the Report No.: RF150624E06-1 design is as the following:
 - ◆ Add DFS band <5.26GHz ~ 5.32GHz, 5.5GHz ~ 5.7GHz>
2. According to above condition, all test items need to be performed. And all data weres verified to meet the requirements.
3. 2.4GHz and 5GHz technology can transmit at same time.
4. The antennas provided to the EUT, please refer to the following table:

External Antenna									
PCB Chain No.	Brand	Model	Antenna Gain (dBi) (Excelude cable loss)	Cable Loss (dB)	Net Gain (dBi)	Cable Length (mm)	Frequency range (GHz to GHz)	Antenna Type	Connector Type
Chain (0) (Left)	Master Wave Tech.	98364PRSX004	0.8	0.8	0	180	2.4~2.4835	Dipole	R-SMA
			1.5	1.5	0		5.15~5.25		
			1.6	1.5	0.1		5.25~5.35		
			0.7	1.5	-0.8		5.47~5.725		
			0.5	1.5	-1		5.725~5.85		
Chain (1) (Right)	Master Wave Tech.	98364PRSX004	0.8	0.9	-0.1	190	2.4~2.4835	Dipole	R-SMA
			1.5	1.7	-0.2		5.15~5.25		
			1.6	1.7	-0.1		5.25~5.35		
			0.7	1.7	-1		5.47~5.725		
			0.5	1.7	-1.2		5.725~5.85		
Internal Antenna									
PCB Chain No.	Brand	Model	Antenna Gain (dBi)	Frequency range (GHz to GHz)	Antenna Type	Connector Type			
Chain (0)	NA	NA	5	2.4~2.4835	PIFA	i-pex(MHF)			
			6	5.15~5.25					
			6	5.25~5.35					
			6	5.47~5.725					
			6	5.725~5.85					
Chain (1)	NA	NA	5	2.4~2.4835	PIFA	i-pex(MHF)			
			6	5.15~5.25					
			6	5.25~5.35					
			6	5.47~5.725					
			6	5.725~5.85					

5. The EUT must be supplied with POE or a power adapter and following two different models could be chosen as following table:

Adapter				
No	Brand Name	Model No.	P/N	Spec.
1	NETGEAR	2ABL030F 1	332-10758-01	Input: 100-120V, 1.0A, 50/60Hz Output: 12V, 2.5A DC output cable: 1.8m, unshielded
2	NETGEAR	ADS-40FPA-12	332-10759-01	Input: 100-120V, 1.0A, 60Hz Output: 12V, 2.5A DC output cable: 1.8m, unshielded
POE (test only, not for sale)				
No	Brand Name	Model No.	Spec.	
1	Microsemi Corp.	PD-9001GR/AC	Input: 100-240V, 0.8A, 50/60Hz Output: 55V, 0.6A	

Note: From the above adapters & POE, the radiated emission worse case was found in adapter 2. Therefore only the test data of the mode was recorded in this report.

6. The EUT incorporates a MIMO function with beamforming. (Except for 802.11a/b/g)

2.4GHz Band			
MODULATION MODE	DATA RATE (MCS)	TX & RX CONFIGURATION	
802.11b	1 ~ 11Mbps	2TX	2RX
802.11g	6 ~ 54Mbps	2TX	2RX
802.11n (HT20)	MCS 0~7	2TX	2RX
	MCS 8~15	2TX	2RX
802.11n (HT40)	MCS 0~7	2TX	2RX
	MCS 8~15	2TX	2RX
5GHz Band			
MODULATION MODE	DATA RATE (MCS)	TX & RX CONFIGURATION	
802.11a	6 ~ 54Mbps	2TX	2RX
802.11n (HT20)	MCS 0~7	2TX	2RX
	MCS 8~15	2TX	2RX
802.11n (HT40)	MCS 0~7	2TX	2RX
	MCS 8~15	2TX	2RX
802.11ac (VHT20)	MCS 0~8, Nss=1	2TX	2RX
	MCS 0~8, Nss=2	2TX	2RX
802.11ac (VHT40)	MCS 0~9, Nss=1	2TX	2RX
	MCS 0~9, Nss=2	2TX	2RX
802.11ac (VHT80)	MCS 0~9, Nss=1	2TX	2RX
	MCS 0~9, Nss=2	2TX	2RX

The modulation and bandwidth are similar for 802.11n mode for 20MHz (40MHz) and 802.11ac mode for 20MHz (40MHz), therefore investigated worst case to representative mode in test report. (Final test mode refer section 3.2.1)

7. The emission of the simultaneous operation (2.4GHz & 5GHz) has been evaluated and no non-compliance was found.

8. The above EUT information is declared by manufacturer and for more detailed features description, please refer to the manufacturer's specifications or user's manual.

3.2 Description of Test Modes

For 5260 ~ 5320MHz

4 channels are provided for 802.11a, 802.11n (HT20), 802.11ac (VHT20):

Channel	Frequency	Channel	Frequency
52	5260 MHz	60	5300 MHz
56	5280 MHz	64	5320 MHz

2 channels are provided for 802.11n (HT40), 802.11ac (VHT40):

Channel	Frequency	Channel	Frequency
54	5270 MHz	62	5310 MHz

1 channel is provided for 802.11ac (VHT80):

Channel	Frequency
58	5290MHz

For 5500 ~ 5700MHz

11 channels are provided for 802.11a, 802.11n (HT20), 802.11ac (VHT20):

Channel	Frequency	Channel	Frequency
100	5500 MHz	124	5620 MHz
104	5520 MHz	128	5640 MHz
108	5540 MHz	132	5660 MHz
112	5560 MHz	136	5680 MHz
116	5580 MHz	140	5700 MHz
120	5600 MHz		

5 channels are provided for 802.11n (HT40), 802.11ac (VHT40):

Channel	Frequency	Channel	Frequency
102	5510 MHz	126	5630 MHz
110	5550 MHz	134	5670 MHz
118	5590 MHz		

2 channels are provided for 802.11ac (VHT80):

Channel	Frequency	Channel	Frequency
106	5530MHz	122	5610MHz

3.2.1 Test Mode Applicability and Tested Channel Detail

EUT CONFIGURE MODE	APPLICABLE TO				DESCRIPTION
	RE≥1G	RE<1G	PLC	APCM	
1	√	√	-	-	With adapter 2 + External antenna
2	√	√	√	√	With adapter 2 + Internal antenna
3	-	-	√	-	With adapter 1 + Internal antenna
4	-	-	√	-	With POE + Internal antenna

Where **RE≥1G**: Radiated Emission above 1GHz **RE<1G**: Radiated Emission below 1GHz
PLC: Power Line Conducted Emission **APCM**: Antenna Port Conducted Measurement

NOTE: 1. The EUT had been pre-tested on the positioned of each 2 axis. The worst case was found when positioned on **X-plane (below 1GHz) & Y-plane (above 1GHz)**.
2. "-" means no effect.

Radiated Emission Test (Above 1GHz):

- Pre-Scan has been conducted to determine the worst-case mode from all possible combinations between available modulations, data rates and antenna ports (if EUT with antenna diversity architecture).
- Following channel(s) was (were) selected for the final test as listed below.

CDD MODE						
MODE	FREQ. BAND (MHz)	AVAILABLE CHANNEL	TESTED CHANNEL	MODULATION TECHNOLOGY	MODULATION TYPE	DATA RATE (Mbps)
802.11a	5260-5320	52 to 64	52, 60, 64	OFDM	BPSK	6
802.11ac (VHT20)		52 to 64	52, 60, 64	OFDM	BPSK	6.5
802.11ac (VHT40)		54 to 62	54, 62	OFDM	BPSK	13.5
802.11ac (VHT80)		58	58	OFDM	BPSK	29.3
802.11a	5500-5700	100 to 140	100, 116, 140	OFDM	BPSK	6
802.11ac (VHT20)		100 to 140	100, 116, 140	OFDM	BPSK	6.5
802.11ac (VHT40)		102 to 134	102, 110, 134	OFDM	BPSK	13.5
802.11ac (VHT80)		106 to 122	106, 122	OFDM	BPSK	29.3

Radiated Emission Test (Below 1GHz):

- Pre-Scan has been conducted to determine the worst-case mode from all possible combinations between available modulations, data rates and antenna ports (if EUT with antenna diversity architecture).
- Following channel(s) was (were) selected for the final test as listed below.

CDD MODE						
MODE	FREQ. BAND (MHz)	AVAILABLE CHANNEL	TESTED CHANNEL	MODULATION TECHNOLOGY	MODULATION TYPE	DATA RATE (Mbps)
802.11ac (VHT40)	5260-5320 5500-5700	54 to 62 102 to 134	54	OFDM	BPSK	13.5

Power Line Conducted Emission Test:

- Pre-Scan has been conducted to determine the worst-case mode from all possible combinations between available modulations, data rates and antenna ports (if EUT with antenna diversity architecture).
- Following channel(s) was (were) selected for the final test as listed below.

CDD MODE						
MODE	FREQ. BAND (MHz)	AVAILABLE CHANNEL	TESTED CHANNEL	MODULATION TECHNOLOGY	MODULATION TYPE	DATA RATE (Mbps)
802.11ac (VHT40)	5260-5320 5500-5700	54 to 62 102 to 134	54	OFDM	BPSK	13.5

Antenna Port Conducted Measurement:

- This item includes all test value of each mode, but only includes spectrum plot of worst value of each mode.
- Pre-Scan has been conducted to determine the worst-case mode from all possible combinations between available modulations, data rates and antenna ports (if EUT with antenna diversity architecture).
- Following channel(s) was (were) selected for the final test as listed below.

CDD MODE						
For Transmit Power / Power Spectral Density Measurement						
MODE	FREQ. BAND (MHz)	AVAILABLE CHANNEL	TESTED CHANNEL	MODULATION TECHNOLOGY	MODULATION TYPE	DATA RATE (Mbps)
802.11a	5260-5320	52 to 64	52, 60, 64	OFDM	BPSK	6
802.11ac (VHT20)		52 to 64	52, 60, 64	OFDM	BPSK	6.5
802.11ac (VHT40)		54 to 62	54, 62	OFDM	BPSK	13.5
802.11ac (VHT80)		58	58	OFDM	BPSK	29.3
802.11a	5500-5700	100 to 140	100, 116, 140	OFDM	BPSK	6
802.11ac (VHT20)		100 to 140	100, 116, 140	OFDM	BPSK	6.5
802.11ac (VHT40)		102 to 134	102, 110, 134	OFDM	BPSK	13.5
802.11ac (VHT80)		106 to 122	106, 122	OFDM	BPSK	29.3
Beamforming MODE						
For Transmit Power Measurement						
MODE	FREQ. BAND (MHz)	AVAILABLE CHANNEL	TESTED CHANNEL	MODULATION TECHNOLOGY	MODULATION TYPE	DATA RATE (Mbps)
802.11ac (VHT20)	5260-5320	52 to 64	52, 60, 64	OFDM	BPSK	6.5
802.11ac (VHT40)		54 to 62	54, 62	OFDM	BPSK	13.5
802.11ac (VHT80)		58	58	OFDM	BPSK	29.3
802.11ac (VHT20)	5500-5700	100 to 140	100, 116, 140	OFDM	BPSK	6.5
802.11ac (VHT40)		102 to 134	102, 110, 134	OFDM	BPSK	13.5
802.11ac (VHT80)		106 to 122	106, 122	OFDM	BPSK	29.3

Test Condition:

APPLICABLE TO	ENVIRONMENTAL CONDITIONS	INPUT POWER	TESTED BY
RE \geq 1G	25deg. C, 71%RH 22deg. C, 68%RH	120Vac, 60Hz	Gary Cheng
RE $<$ 1G	25deg. C, 69%RH	120Vac, 60Hz	Andy Ho
PLC	26deg. C, 63%RH	120Vac, 60Hz	Gavin Peng
APCM	25deg. C, 60%RH	120Vac, 60Hz	Anderson Chen

3.3 Duty Cycle of Test Signal

If duty cycle of test signal is $\geq 98\%$, duty factor is not required.

If duty cycle of test signal is $< 98\%$, duty factor shall be considered.

802.11a: Duty cycle = $2.062 \text{ ms} / 2.082 \text{ ms} = 0.99$

802.11ac (VHT20): Duty cycle = $1.916 \text{ ms} / 1.953 \text{ ms} = 0.981$

802.11ac (VHT40): Duty cycle = $0.944 \text{ ms} / 0.963 \text{ ms} = 0.98$

802.11ac (VHT80): Duty cycle = $0.458 \text{ ms} / 0.5 \text{ ms} = 0.916$, Duty factor = $10 * \log(1/0.916) = 0.38$

802.11a 802.11ac (VHT20)

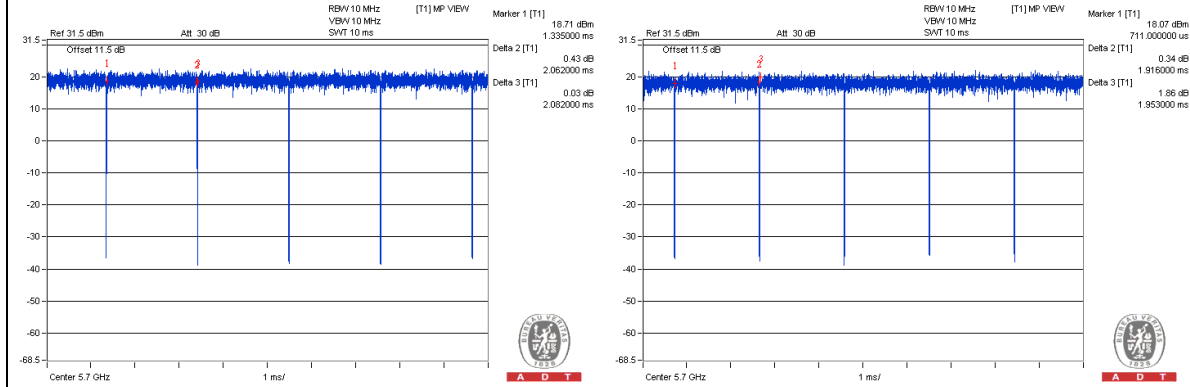

802.11ac (VHT40) 802.11ac (VHT80)

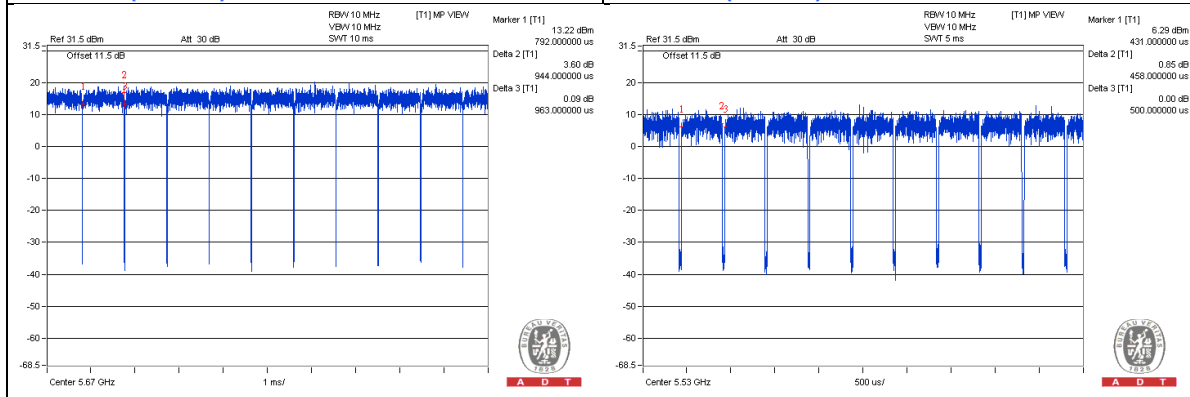

3.4 Description of Support Units

The EUT has been tested as an independent unit together with other necessary accessories or support units. The following support units or accessories were used to form a representative test configuration during the tests.

With adapter test Mode

ID	Product	Brand	Model No.	Serial No.	FCC ID	Remarks
A.	NOTEBOOK COMPUTER	DELL	PP32LA	DSL32S	FCC DoC	Provided by Lab

Note:

1. All power cords of the above support units are non-shielded (1.8m).

ID	Descriptions	Qty.	Length (m)	Shielding (Yes/No)	Cores (Qty.)	Remarks
1.	DC	1	1.8	No	0	Supplied by Client
2.	RJ-45	1	10	No	0	Provided by Lab
3.	RJ-45 to RS232	1	1	No	0	Provided by Lab

With POE test Mode

ID	Product	Brand	Model No.	Serial No.	FCC ID	Remarks
A	NOTEBOOK COMPUTER	DELL	PP32LA	DSL32S	FCC DoC	Provided by Lab
B	POE	Microsemi Corp.	PD-9001GR/AC	NA	NA	Supplied by Client

Note:

1. All power cords of the above support units are non-shielded (1.8m).

ID	Descriptions	Qty.	Length (m)	Shielding (Yes/No)	Cores (Qty.)	Remarks
1.	RJ-45	1	10	No	0	Supplied by Client
2.	RJ-45	1	3	No	0	Provided by Lab
3.	RJ-45 to RS232	1	1	No	0	Provided by Lab

3.4.1 Configuration of System under Test

With adapter test Mode

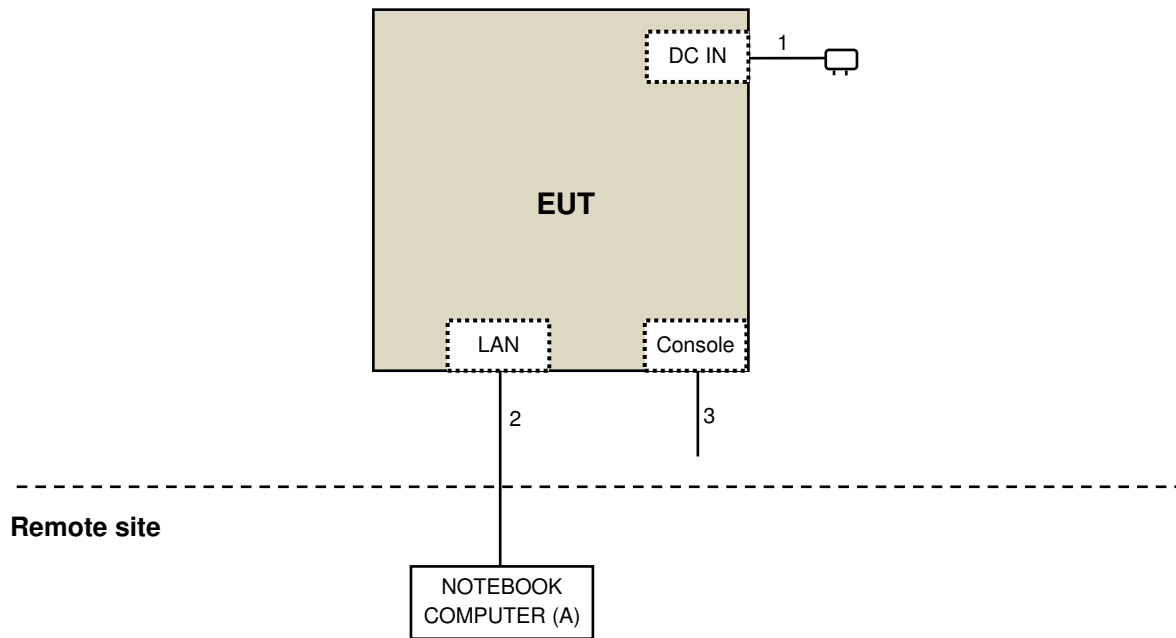

With POE test mode

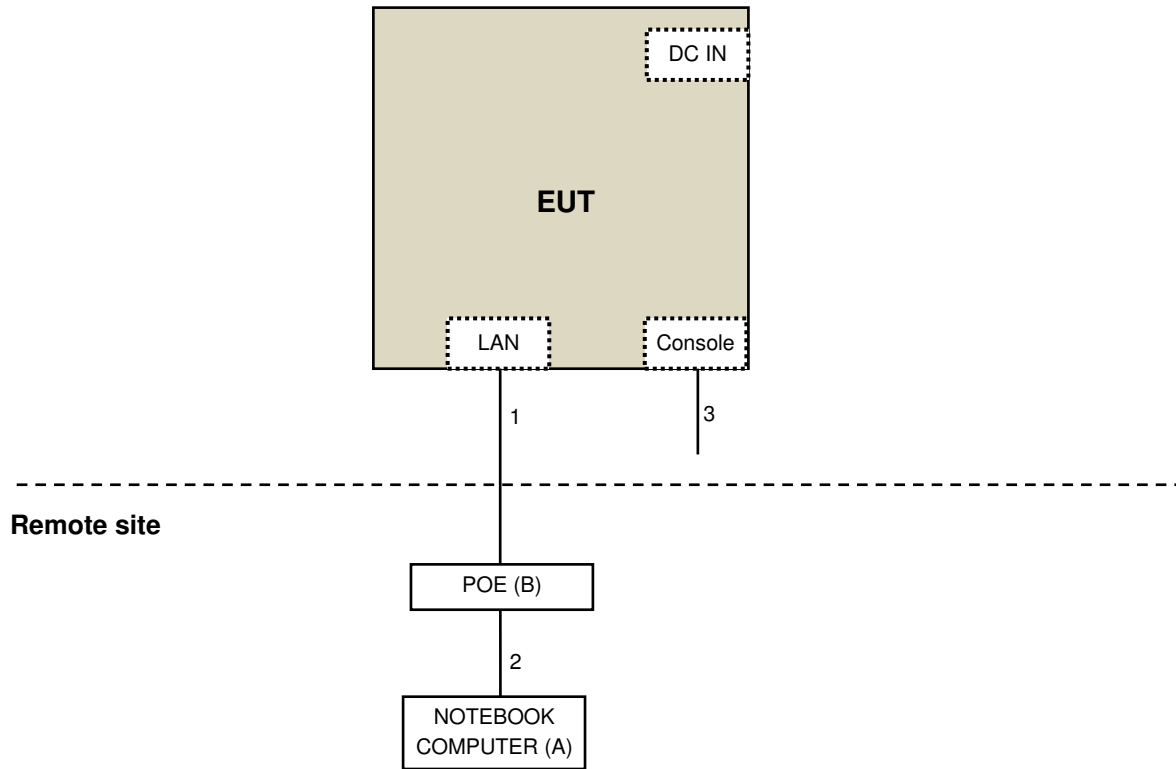

3.5 General Description of Applied Standard

The EUT is a RF Product. According to the specifications of the manufacturer, it must comply with the requirements of the following standards:

FCC Part 15, Subpart E (15.407)

KDB 789033 D02 General UNII Test Procedure New Rules v01r02

KDB 662911 D01 Multiple Transmitter Output v02r01

ANSI C63.10-2013

All test items have been performed and recorded as per the above standards.

NOTE: The EUT has been verified to comply with the requirements of FCC Part 15, Subpart B, Class B (DoC). The test report has been issued separately.

4 Test Types and Results

4.1 Radiated Emission and Bandedge Measurement

4.1.1 Limits of Radiated Emission and Bandedge Measurement

Radiated emissions which fall in the restricted bands must comply with the radiated emission limits specified as below table.

Frequencies (MHz)	Field Strength (microvolts/meter)	Measurement Distance (meters)
0.009 ~ 0.490	2400/F(kHz)	300
0.490 ~ 1.705	24000/F(kHz)	30
1.705 ~ 30.0	30	30
30 ~ 88	100	3
88 ~ 216	150	3
216 ~ 960	200	3
Above 960	500	3

NOTE:

1. The lower limit shall apply at the transition frequencies.
2. Emission level (dBuV/m) = 20 log Emission level (uV/m).
3. For frequencies above 1000MHz, the field strength limits are based on average detector, however, the peak field strength of any emission shall not exceed the maximum permitted average limits, specified above by more than 20dB under any condition of modulation.

LIMITS OF UNWANTED EMISSION OUT OF THE RESTRICTED BANDS

APPLICABLE TO	LIMIT	
789033 D02 General UNII Test Procedure New Rules v01r02	FIELD STRENGTH AT 3m	
	PK:74 (dBμV/m)	AV:54 (dBμV/m)
APPLICABLE TO	EIRP LIMIT	EQUIVALENT FIELD STRENGTH AT 3m
15.407(b)(1)	PK:-27 (dBm/MHz)	PK:68.2(dBμV/m)
15.407(b)(2)		
15.407(b)(3)		
15.407(b)(4)	PK:-27 (dBm/MHz) ^{*1} PK:-17 (dBm/MHz) ^{*2}	PK: 68.2(dBμV/m) ^{*1} PK:78.2 (dBμV/m) ^{*2}

NOTE: ^{*1} beyond 10MHz of the band edge ^{*2} within 10 MHz of band edge

The following formula is used to convert the equipment isotropic radiated power (eirp) to field strength:

$$E = \frac{1000000\sqrt{30P}}{3} \mu\text{V/m, where P is the eirp (Watts).}$$



4.1.2 Test Instruments

For below 1GHz test:

DESCRIPTION & MANUFACTURER	MODEL NO.	SERIAL NO.	CALIBRATED DATE	CALIBRATED UNTIL
Test Receiver Agilent	N9038A	MY51210202	Dec. 12, 2014	Dec. 11, 2015
Pre-Amplifier Mini-Circuits	ZFL-1000VH2 B	AMP-ZFL-04	Nov. 12, 2014	Nov. 11, 2015
Trilog Broadband Antenna SCHWARZBECK	VULB 9168	9168-361	Feb. 09, 2015	Feb. 08, 2016
RF Cable	8D-FB	CHHCAB-001- 1 CHHCAB-001- 2	Oct. 04, 2015	Oct. 03, 2016
	RF-141	CHHCAB-004	Oct. 04, 2015	Oct. 03, 2016
Software	ADT_Radiated _V8.7.07	NA	NA	NA
Antenna Tower & Turn Table CT	NA	NA	NA	NA

Note:

1. The calibration interval of the above test instruments is 12 months and the calibrations are traceable to NML/ROC and NIST/USA.
2. The test was performed in 966 Chamber No. H.
3. The FCC Site Registration No. is 797305.
4. The CANADA Site Registration No. is IC 7450H-3.
5. Tested Date: Oct. 29, 2015



For above 1GHz test:

DESCRIPTION & MANUFACTURER	MODEL NO.	SERIAL NO.	CALIBRATED DATE	CALIBRATED UNTIL
Test Receiver Agilent	N9038A	MY51210105	July 24, 2015	July 23, 2016
Horn_Antenna AISI	AIH.8018	000032009111 0	Feb. 09, 2015	Feb. 08, 2016
Pre-Amplifier Agilent	8449B	3008A02578	June 23, 2015	June 22, 2016
RF Cable	NA	131205 131216 131217 SNMY23684/ 4	Jan. 16, 2015	Jan. 15, 2016
Spectrum Analyzer R&S	FSV40	100964	June 26, 2015	June 25, 2016
Pre-Amplifier SPACEK LABS	SLKKa-48-6	9K16	Dec. 12, 2014	Dec. 11, 2015
Horn_Antenna SCHWARZBECK	BBHA 9170	9170-424	Feb. 05, 2015	Feb. 04, 2016
RF Cable	NA	329751/4 RF104-204	Dec. 11, 2014	Dec. 10, 2015
Software	ADT_Radiated _V8.7.07	NA	NA	NA
Antenna Tower & Turn Table CT	NA	NA	NA	NA
Temperature & Humidity Chamber GIANTFORCE	GTH-150-40-S P-AR	MAA0812-00 8	Jan. 12, 2015	Jan. 11, 2016
Spectrum Analyzer R&S	FSV 40	100964	June 26, 2015	June 25, 2016
Power Meter Anritsu	ML2495A	1014008	Apr. 28, 2015	Apr. 27, 2016
Power Sensor Anritsu	MA2411B	0917122	Apr. 28, 2015	Apr. 27, 2016

Note:

1. The calibration interval of the above test instruments is 12 months and the calibrations are traceable to NML/ROC and NIST/USA.
2. The test was performed in 966 Chamber No. G.
3. The FCC Site Registration No. is 966073.
4. The VCCI Site Registration No. is G-137.
5. The CANADA Site Registration No. is IC 7450H-2.
6. Tested Date: Oct. 28 to Nov. 16, 2015

4.1.3 Test Procedure

- a. The EUT was placed on the top of a rotating table 0.8 meters (for below 1GHz) / 1.5 meters (for above 1GHz) above the ground at 3 meter chamber room for test. The table was rotated 360 degrees to determine the position of the highest radiation.
- b. The EUT was set 3 meters away from the interference-receiving antenna, which was mounted on the top of a variable-height antenna tower.
- c. The height of antenna is varied from one meter to four meters above the ground to determine the maximum value of the field strength. Both horizontal and vertical polarizations of the antenna are set to make the measurement.
- d. For each suspected emission, the EUT was arranged to its worst case and then the antenna was tuned to heights from 1 meter to 4 meters and the rotatable table was turned from 0 degrees to 360 degrees to find the maximum reading.
- e. The test-receiver system was set to quasi-peak detect function and specified bandwidth with maximum hold mode when the test frequency is below 1 GHz.
- f. The test-receiver system was set to peak and average detect function and specified bandwidth with maximum hold mode when the test frequency is above 1 GHz. If the peak reading value also meets average limit, measurement with the average detector is unnecessary.

Note:

1. The resolution bandwidth and video bandwidth of test receiver/spectrum analyzer is 120kHz for Quasi-peak detection (QP) at frequency below 1GHz.
2. The resolution bandwidth of test receiver/spectrum analyzer is 1 MHz and the video bandwidth is 3 MHz for Peak detection (PK) at frequency above 1GHz.
3. The resolution bandwidth of test receiver/spectrum analyzer is 1MHz and the video bandwidth is 3MHz for RMS Average (Duty cycle < 98%) for Average detection (AV) at frequency above 1GHz, then the measurement results was added to a correction factor ($10 \log(1/\text{duty cycle})$).
4. The resolution bandwidth of test receiver/spectrum analyzer is 1MHz and the video bandwidth is 10Hz (Duty cycle \geq 98%) for Average detection (AV) at frequency above 1GHz.
5. All modes of operation were investigated and the worst-case emissions are reported.

4.1.4 Deviation from Test Standard

No deviation.

4.1.5 Test Setup

<Frequency Range below 1GHz>

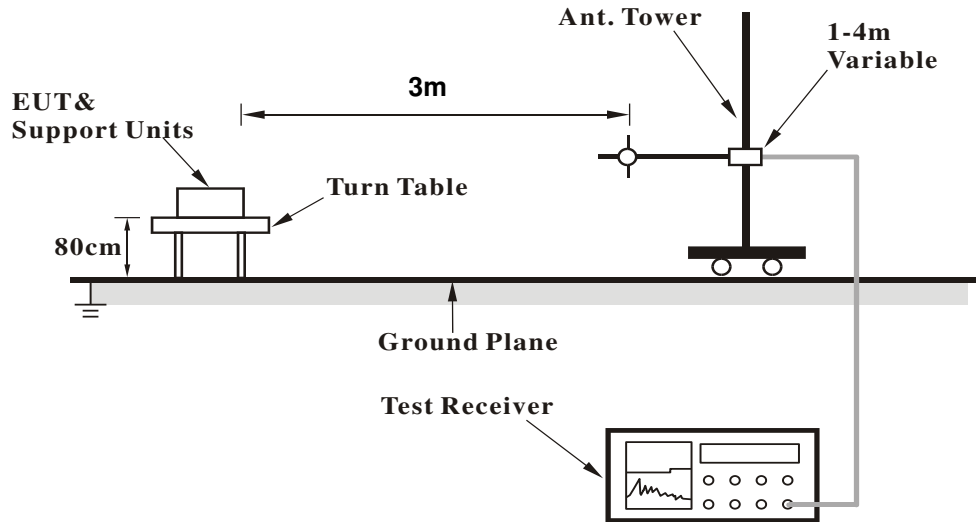

<Frequency Range above 1GHz>

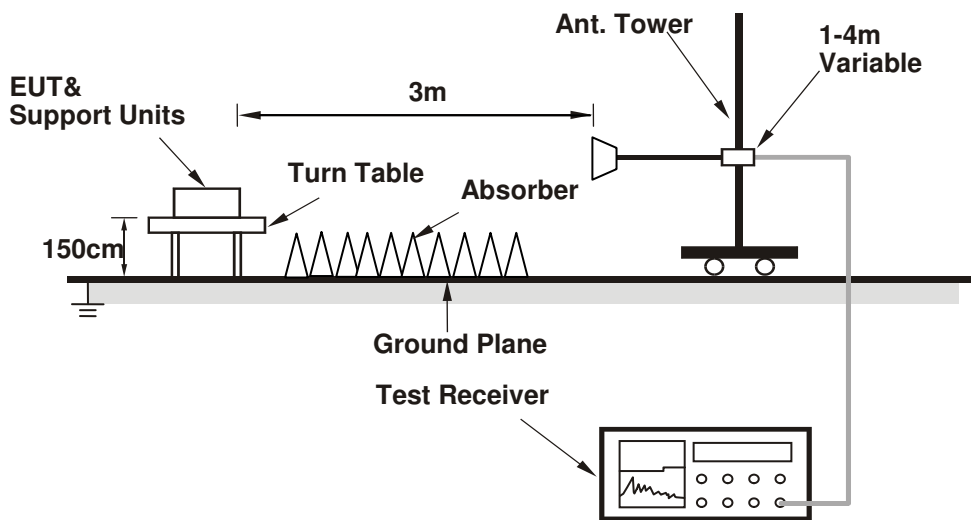

For the actual test configuration, please refer to the attached file (Test Setup Photo).

4.1.6 EUT Operating Condition

1. Connect the EUT with the support unit A (NOTEBOOK COMPUTER) which is placed on remote site.
2. Controlling software (Mtool.exe V1.0.0.10) has been activated to set the EUT on specific status.

4.1.7 Test Results (Mode 1)

Above 1GHz Data

CDD Mode

802.11a

CHANNEL	TX Channel 52	DETECTOR FUNCTION	Peak (PK)
FREQUENCY RANGE	1GHz ~ 40GHz		Average (AV)

ANTENNA POLARITY & TEST DISTANCE: HORIZONTAL AT 3 M

NO.	FREQ. (MHz)	EMISSION LEVEL (dBuV/m)	LIMIT (dBuV/m)	MARGIN (dB)	ANTENNA HEIGHT (m)	TABLE ANGLE (Degree)	RAW VALUE (dBuV)	CORRECTION FACTOR (dB/m)
1	5150.00	53.6 PK	74.0	-20.4	1.46 H	360	48.63	4.97
2	5150.00	45.6 AV	54.0	-8.4	1.46 H	360	40.63	4.97
3	*5260.00	103.6 PK			1.46 H	360	98.45	5.15
4	*5260.00	93.6 AV			1.46 H	360	88.45	5.15
5	5418.00	59.4 PK	74.0	-14.6	1.46 H	360	53.85	5.55
6	5418.00	49.6 AV	54.0	-4.4	1.46 H	360	44.05	5.55
7	#5498.00	58.4 PK	74.0	-15.6	1.54 H	302	52.70	5.70
8	#5498.00	47.6 AV	54.0	-6.4	1.54 H	302	41.90	5.70
9	#10520.00	50.5 PK	74.0	-23.5	1.67 H	360	34.18	16.32
10	#10520.00	36.5 AV	54.0	-17.5	1.67 H	360	20.18	16.32
11	15780.00	51.7 PK	74.0	-22.3	1.41 H	332	34.60	17.10
12	15780.00	37.6 AV	54.0	-16.4	1.41 H	332	20.50	17.10

ANTENNA POLARITY & TEST DISTANCE: VERTICAL AT 3 M

NO.	FREQ. (MHz)	EMISSION LEVEL (dBuV/m)	LIMIT (dBuV/m)	MARGIN (dB)	ANTENNA HEIGHT (m)	TABLE ANGLE (Degree)	RAW VALUE (dBuV)	CORRECTION FACTOR (dB/m)
1	5150.00	61.4 PK	74.0	-12.6	1.70 V	325	56.43	4.97
2	5150.00	50.8 AV	54.0	-3.2	1.70 V	325	45.83	4.97
3	*5260.00	111.4 PK			1.70 V	325	106.25	5.15
4	*5260.00	101.2 AV			1.70 V	325	96.05	5.15
5	5418.00	64.2 PK	74.0	-9.8	1.70 V	325	58.65	5.55
6	5418.00	53.1 AV	54.0	-0.9	1.70 V	325	47.55	5.55
7	#5498.00	60.5 PK	74.0	-13.5	1.46 V	330	54.80	5.70
8	#5498.00	49.4 AV	54.0	-4.6	1.46 V	330	43.70	5.70
9	#10520.00	50.6 PK	74.0	-23.4	2.11 V	313	34.28	16.32
10	#10520.00	37.0 AV	54.0	-17.0	2.11 V	313	20.68	16.32
11	15780.00	50.7 PK	74.0	-23.3	1.83 V	356	33.60	17.10
12	15780.00	38.1 AV	54.0	-15.9	1.83 V	356	21.00	17.10

REMARKS:

1. Emission Level(dBuV/m) = Raw Value(dBuV) + Correction Factor(dB/m)
2. Correction Factor(dB/m) = Antenna Factor(dB/m) + Cable Factor(dB) – Pre-Amplifier Factor(dB)
3. The other emission levels were very low against the limit.
4. Margin value = Emission Level – Limit value
5. " * ": Fundamental frequency.
6. " # ": The radiated frequency is out of the restricted band.



CHANNEL	TX Channel 60	DETECTOR FUNCTION	Peak (PK)
FREQUENCY RANGE	1GHz ~ 40GHz		Average (AV)

ANTENNA POLARITY & TEST DISTANCE: HORIZONTAL AT 3 M

NO.	FREQ. (MHz)	EMISSION LEVEL (dBuV/m)	LIMIT (dBuV/m)	MARGIN (dB)	ANTENNA HEIGHT (m)	TABLE ANGLE (Degree)	RAW VALUE (dBuV)	CORRECTION FACTOR (dB/m)
1	*5300.00	102.3 PK			1.42 H	354	97.08	5.22
2	*5300.00	92.4 AV			1.42 H	354	87.18	5.22
3	5458.00	60.2 PK	74.0	-13.8	1.42 H	354	54.58	5.62
4	5458.00	49.6 AV	54.0	-4.4	1.42 H	354	43.98	5.62
5	10600.00	50.2 PK	74.0	-23.8	1.71 H	360	33.75	16.45
6	10600.00	36.1 AV	54.0	-17.9	1.71 H	360	19.65	16.45
7	15900.00	51.9 PK	74.0	-22.1	1.39 H	331	35.34	16.56
8	15900.00	38.0 AV	54.0	-16.0	1.39 H	331	21.44	16.56

ANTENNA POLARITY & TEST DISTANCE: VERTICAL AT 3 M

NO.	FREQ. (MHz)	EMISSION LEVEL (dBuV/m)	LIMIT (dBuV/m)	MARGIN (dB)	ANTENNA HEIGHT (m)	TABLE ANGLE (Degree)	RAW VALUE (dBuV)	CORRECTION FACTOR (dB/m)
1	*5300.00	110.3 PK			1.76 V	326	105.08	5.22
2	*5300.00	101.4 AV			1.76 V	326	96.18	5.22
3	5458.00	64.0 PK	74.0	-10.0	1.64 V	12	58.38	5.62
4	5458.00	52.6 AV	54.0	-1.4	1.64 V	12	46.98	5.62
5	10600.00	50.0 PK	74.0	-24.0	2.08 V	326	33.55	16.45
6	10600.00	36.7 AV	54.0	-17.3	2.08 V	326	20.25	16.45
7	15900.00	50.4 PK	74.0	-23.6	1.87 V	360	33.84	16.56
8	15900.00	37.8 AV	54.0	-16.2	1.87 V	360	21.24	16.56

REMARKS:

1. Emission Level(dBuV/m) = Raw Value(dBuV) + Correction Factor(dB/m)
2. Correction Factor(dB/m) = Antenna Factor(dB/m) + Cable Factor(dB) – Pre-Amplifier Factor(dB)
3. The other emission levels were very low against the limit.
4. Margin value = Emission Level – Limit value
5. " * ": Fundamental frequency.

CHANNEL	TX Channel 64	DETECTOR FUNCTION	Peak (PK)
FREQUENCY RANGE	1GHz ~ 40GHz		Average (AV)

ANTENNA POLARITY & TEST DISTANCE: HORIZONTAL AT 3 M

NO.	FREQ. (MHz)	EMISSION LEVEL (dBuV/m)	LIMIT (dBuV/m)	MARGIN (dB)	ANTENNA HEIGHT (m)	TABLE ANGLE (Degree)	RAW VALUE (dBuV)	CORRECTION FACTOR (dB/m)
1	*5320.00	104.7 PK			1.44 H	356	99.42	5.28
2	*5320.00	95.7 AV			1.44 H	356	90.42	5.28
3	5350.00	62.4 PK	74.0	-11.6	1.44 H	356	57.04	5.36
4	5350.00	47.6 AV	54.0	-6.4	1.44 H	356	42.24	5.36
5	5398.50	59.2 PK	74.0	-14.8	1.56 H	306	53.70	5.50
6	5398.50	48.6 AV	54.0	-5.4	1.56 H	306	43.10	5.50
7	10640.00	49.8 PK	74.0	-24.2	1.67 H	360	33.47	16.33
8	10640.00	35.3 AV	54.0	-18.7	1.67 H	360	18.97	16.33
9	15960.00	51.4 PK	74.0	-22.6	1.51 H	336	34.70	16.70
10	15960.00	37.5 AV	54.0	-16.5	1.51 H	336	20.80	16.70

ANTENNA POLARITY & TEST DISTANCE: VERTICAL AT 3 M

NO.	FREQ. (MHz)	EMISSION LEVEL (dBuV/m)	LIMIT (dBuV/m)	MARGIN (dB)	ANTENNA HEIGHT (m)	TABLE ANGLE (Degree)	RAW VALUE (dBuV)	CORRECTION FACTOR (dB/m)
1	*5320.00	111.5 PK			1.72 V	301	106.22	5.28
2	*5320.00	102.6 AV			1.72 V	301	97.32	5.28
3	5350.00	67.7 PK	74.0	-6.3	1.72 V	301	62.34	5.36
4	5350.00	52.6 AV	54.0	-1.4	1.72 V	301	47.24	5.36
5	5398.50	63.9 PK	74.0	-10.1	1.68 V	278	58.40	5.50
6	5398.50	53.1 AV	54.0	-0.9	1.68 V	278	47.60	5.50
7	10640.00	50.1 PK	74.0	-23.9	2.10 V	310	33.77	16.33
8	10640.00	36.7 AV	54.0	-17.3	2.10 V	310	20.37	16.33
9	15960.00	51.0 PK	74.0	-23.0	1.89 V	360	34.30	16.70
10	15960.00	38.5 AV	54.0	-15.5	1.89 V	360	21.80	16.70

REMARKS:

1. Emission Level(dBuV/m) = Raw Value(dBuV) + Correction Factor(dB/m)
2. Correction Factor(dB/m) = Antenna Factor(dB/m) + Cable Factor(dB) – Pre-Amplifier Factor(dB)
3. The other emission levels were very low against the limit.
4. Margin value = Emission Level – Limit value
5. " * ": Fundamental frequency.



CHANNEL	TX Channel 100	DETECTOR FUNCTION	Peak (PK)
FREQUENCY RANGE	1GHz ~ 40GHz		Average (AV)

ANTENNA POLARITY & TEST DISTANCE: HORIZONTAL AT 3 M

NO.	FREQ. (MHz)	EMISSION LEVEL (dBuV/m)	LIMIT (dBuV/m)	MARGIN (dB)	ANTENNA HEIGHT (m)	TABLE ANGLE (Degree)	RAW VALUE (dBuV)	CORRECTION FACTOR (dB/m)
1	5418.00	54.7 PK	74.0	-19.3	1.77 H	278	49.15	5.55
2	5418.00	48.4 AV	54.0	-5.6	1.77 H	278	42.85	5.55
3	#5470.00	66.4 PK	74.0	-7.6	1.46 H	354	60.76	5.64
4	#5470.00	45.4 AV	54.0	-8.6	1.46 H	354	39.76	5.64
5	*5500.00	107.4 PK			1.46 H	354	101.70	5.70
6	*5500.00	96.9 AV			1.46 H	354	91.20	5.70
7	#5738.00	59.3 PK	74.0	-14.7	1.40 H	300	53.12	6.18
8	#5738.00	47.4 AV	54.0	-6.6	1.40 H	300	41.22	6.18
9	11000.00	49.4 PK	74.0	-24.6	1.70 H	360	32.22	17.18
10	11000.00	35.0 AV	54.0	-19.0	1.70 H	360	17.82	17.18
11	#16500.00	51.5 PK	74.0	-22.5	1.56 H	345	31.96	19.54
12	#16500.00	37.7 AV	54.0	-16.3	1.56 H	345	18.16	19.54

ANTENNA POLARITY & TEST DISTANCE: VERTICAL AT 3 M

NO.	FREQ. (MHz)	EMISSION LEVEL (dBuV/m)	LIMIT (dBuV/m)	MARGIN (dB)	ANTENNA HEIGHT (m)	TABLE ANGLE (Degree)	RAW VALUE (dBuV)	CORRECTION FACTOR (dB/m)
1	5418.00	63.5 PK	74.0	-10.5	1.56 V	304	57.95	5.55
2	5418.00	53.4 AV	54.0	-0.6	1.56 V	304	47.85	5.55
3	#5470.00	68.3 PK	74.0	-5.7	1.73 V	294	62.66	5.64
4	#5470.00	47.3 AV	54.0	-6.7	1.73 V	294	41.66	5.64
5	*5500.00	114.8 PK			1.73 V	294	109.10	5.70
6	*5500.00	104.0 AV			1.73 V	294	98.30	5.70
7	#5738.00	64.2 PK	74.0	-9.8	1.42 V	278	58.02	6.18
8	#5738.00	53.0 AV	54.0	-1.0	1.42 V	278	46.82	6.18
9	11000.00	49.7 PK	74.0	-24.3	2.04 V	306	32.52	17.18
10	11000.00	36.2 AV	54.0	-17.8	2.04 V	306	19.02	17.18
11	#16500.00	51.1 PK	74.0	-22.9	1.94 V	360	31.56	19.54
12	#16500.00	38.9 AV	54.0	-15.1	1.94 V	360	19.36	19.54

REMARKS:

1. Emission Level(dBuV/m) = Raw Value(dBuV) + Correction Factor(dB/m)
2. Correction Factor(dB/m) = Antenna Factor(dB/m) + Cable Factor(dB) – Pre-Amplifier Factor(dB)
3. The other emission levels were very low against the limit.
4. Margin value = Emission Level – Limit value
5. " * ": Fundamental frequency.
6. " # ": The radiated frequency is out of the restricted band.

CHANNEL	TX Channel 116	DETECTOR FUNCTION	Peak (PK)
FREQUENCY RANGE	1GHz ~ 40GHz		Average (AV)

ANTENNA POLARITY & TEST DISTANCE: HORIZONTAL AT 3 M

NO.	FREQ. (MHz)	EMISSION LEVEL (dBuV/m)	LIMIT (dBuV/m)	MARGIN (dB)	ANTENNA HEIGHT (m)	TABLE ANGLE (Degree)	RAW VALUE (dBuV)	CORRECTION FACTOR (dB/m)
1	5419.00	57.4 PK	74.0	-16.6	1.56 H	360	51.85	5.55
2	5419.00	47.5 AV	54.0	-6.5	1.56 H	360	41.95	5.55
3	*5580.00	105.6 PK			1.56 H	360	99.83	5.77
4	*5580.00	95.8 AV			1.56 H	360	90.03	5.77
5	#5739.00	60.3 PK	74.0	-13.7	1.50 H	298	54.12	6.18
6	#5739.00	48.4 AV	54.0	-5.6	1.50 H	298	42.22	6.18
7	11160.00	48.7 PK	74.0	-25.3	1.67 H	360	31.53	17.17
8	11160.00	34.6 AV	54.0	-19.4	1.67 H	360	17.43	17.17
9	#16740.00	51.4 PK	74.0	-22.6	1.55 H	359	31.72	19.68
10	#16740.00	37.9 AV	54.0	-16.1	1.55 H	359	18.22	19.68

ANTENNA POLARITY & TEST DISTANCE: VERTICAL AT 3 M

NO.	FREQ. (MHz)	EMISSION LEVEL (dBuV/m)	LIMIT (dBuV/m)	MARGIN (dB)	ANTENNA HEIGHT (m)	TABLE ANGLE (Degree)	RAW VALUE (dBuV)	CORRECTION FACTOR (dB/m)
1	5419.00	62.3 PK	74.0	-11.7	1.76 V	301	56.75	5.55
2	5419.00	52.4 AV	54.0	-1.6	1.76 V	301	46.85	5.55
3	*5580.00	112.8 PK			1.76 V	301	107.03	5.77
4	*5580.00	103.0 AV			1.76 V	301	97.23	5.77
5	#5739.00	65.9 PK	74.0	-8.1	1.70 V	286	59.72	6.18
6	#5739.00	53.8 AV	54.0	-0.2	1.70 V	286	47.62	6.18
7	11160.00	49.5 PK	74.0	-24.5	2.08 V	293	32.33	17.17
8	11160.00	35.7 AV	54.0	-18.3	2.08 V	293	18.53	17.17
9	#16740.00	51.4 PK	74.0	-22.6	1.95 V	354	31.72	19.68
10	#16740.00	39.0 AV	54.0	-15.0	1.95 V	354	19.32	19.68

REMARKS:

1. Emission Level(dBuV/m) = Raw Value(dBuV) + Correction Factor(dB/m)
2. Correction Factor(dB/m) = Antenna Factor(dB/m) + Cable Factor(dB) – Pre-Amplifier Factor(dB)
3. The other emission levels were very low against the limit.
4. Margin value = Emission Level – Limit value
5. " * ": Fundamental frequency.
6. " # ": The radiated frequency is out of the restricted band.

CHANNEL	TX Channel 140	DETECTOR FUNCTION	Peak (PK)
FREQUENCY RANGE	1GHz ~ 40GHz		Average (AV)

ANTENNA POLARITY & TEST DISTANCE: HORIZONTAL AT 3 M

NO.	FREQ. (MHz)	EMISSION LEVEL (dBuV/m)	LIMIT (dBuV/m)	MARGIN (dB)	ANTENNA HEIGHT (m)	TABLE ANGLE (Degree)	RAW VALUE (dBuV)	CORRECTION FACTOR (dB/m)
1	*5700.00	107.1 PK			1.55 H	360	101.03	6.07
2	*5700.00	96.4 AV			1.55 H	360	90.33	6.07
3	#5725.00	66.3 PK	74.0	-7.7	1.55 H	360	60.16	6.14
4	#5725.00	47.6 AV	54.0	-6.4	1.55 H	360	41.46	6.14
5	#5859.00	60.4 PK	68.2	-7.8	1.54 H	279	53.99	6.41
6	11400.00	49.3 PK	74.0	-24.7	1.68 H	360	32.13	17.17
7	11400.00	35.1 AV	54.0	-18.9	1.68 H	360	17.93	17.17
8	#17100.00	51.6 PK	74.0	-22.4	1.54 H	356	29.79	21.81
9	#17100.00	38.1 AV	54.0	-15.9	1.54 H	356	16.29	21.81

ANTENNA POLARITY & TEST DISTANCE: VERTICAL AT 3 M

NO.	FREQ. (MHz)	EMISSION LEVEL (dBuV/m)	LIMIT (dBuV/m)	MARGIN (dB)	ANTENNA HEIGHT (m)	TABLE ANGLE (Degree)	RAW VALUE (dBuV)	CORRECTION FACTOR (dB/m)
1	*5700.00	114.6 PK			1.77 V	326	108.53	6.07
2	*5700.00	103.9 AV			1.77 V	326	97.83	6.07
3	#5725.00	72.4 PK	74.0	-1.6	1.77 V	326	66.26	6.14
4	#5725.00	53.2 AV	54.0	-0.8	1.77 V	326	47.06	6.14
5	#5859.00	65.8 PK	68.2	-2.4	1.68 V	342	59.39	6.41
6	11400.00	49.4 PK	74.0	-24.6	2.06 V	303	32.23	17.17
7	11400.00	35.8 AV	54.0	-18.2	2.06 V	303	18.63	17.17
8	#17100.00	51.8 PK	74.0	-22.2	2.00 V	347	29.99	21.81
9	#17100.00	39.2 AV	54.0	-14.8	2.00 V	347	17.39	21.81

REMARKS:

1. Emission Level(dBuV/m) = Raw Value(dBuV) + Correction Factor(dB/m)
2. Correction Factor(dB/m) = Antenna Factor(dB/m) + Cable Factor(dB) – Pre-Amplifier Factor(dB)
3. The other emission levels were very low against the limit.
4. Margin value = Emission Level – Limit value
5. " * ": Fundamental frequency.
6. " # ": The radiated frequency is out of the restricted band.



802.11ac (VHT20)

CHANNEL	TX Channel 52	DETECTOR FUNCTION	Peak (PK)
FREQUENCY RANGE	1GHz ~ 40GHz		Average (AV)

ANTENNA POLARITY & TEST DISTANCE: HORIZONTAL AT 3 M								
NO.	FREQ. (MHz)	EMISSION LEVEL (dBuV/m)	LIMIT (dBuV/m)	MARGIN (dB)	ANTENNA HEIGHT (m)	TABLE ANGLE (Degree)	RAW VALUE (dBuV)	CORRECTION FACTOR (dB/m)
1	5100.00	56.5 PK	74.0	-17.5	1.54 H	360	51.58	4.92
2	5100.00	44.3 AV	54.0	-9.7	1.54 H	360	39.38	4.92
3	*5260.00	104.9 PK			1.54 H	360	99.75	5.15
4	*5260.00	94.5 AV			1.54 H	360	89.35	5.15
5	5422.00	57.3 PK	74.0	-16.7	1.68 H	360	51.75	5.55
6	5422.00	48.4 AV	54.0	-5.6	1.68 H	360	42.85	5.55
7	#10520.00	49.9 PK	74.0	-24.1	1.67 H	359	33.58	16.32
8	#10520.00	36.4 AV	54.0	-17.6	1.67 H	359	20.08	16.32
9	15780.00	49.9 PK	74.0	-24.1	1.46 H	315	32.80	17.10
10	15780.00	36.2 AV	54.0	-17.8	1.46 H	315	19.10	17.10

ANTENNA POLARITY & TEST DISTANCE: VERTICAL AT 3 M								
NO.	FREQ. (MHz)	EMISSION LEVEL (dBuV/m)	LIMIT (dBuV/m)	MARGIN (dB)	ANTENNA HEIGHT (m)	TABLE ANGLE (Degree)	RAW VALUE (dBuV)	CORRECTION FACTOR (dB/m)
1	5100.00	58.2 PK	74.0	-15.8	1.54 V	360	53.28	4.92
2	5100.00	46.6 AV	54.0	-7.4	1.54 V	360	41.68	4.92
3	*5260.00	111.4 PK			1.72 V	354	106.25	5.15
4	*5260.00	101.2 AV			1.72 V	354	96.05	5.15
5	5422.00	62.7 PK	74.0	-11.3	1.77 V	269	57.15	5.55
6	5422.00	52.2 AV	54.0	-1.8	1.77 V	269	46.65	5.55
7	#10520.00	50.3 PK	74.0	-23.7	1.99 V	317	33.98	16.32
8	#10520.00	35.6 AV	54.0	-18.4	1.99 V	317	19.28	16.32
9	15780.00	49.3 PK	74.0	-24.7	1.75 V	324	32.20	17.10
10	15780.00	36.8 AV	54.0	-17.2	1.75 V	324	19.70	17.10

REMARKS:

1. Emission Level(dBuV/m) = Raw Value(dBuV) + Correction Factor(dB/m)
2. Correction Factor(dB/m) = Antenna Factor(dB/m) + Cable Factor(dB) – Pre-Amplifier Factor(dB)
3. The other emission levels were very low against the limit.
4. Margin value = Emission Level – Limit value
5. " * ": Fundamental frequency.
6. " # ": The radiated frequency is out of the restricted band.

CHANNEL	TX Channel 60	DETECTOR FUNCTION	Peak (PK)
FREQUENCY RANGE	1GHz ~ 40GHz		Average (AV)

ANTENNA POLARITY & TEST DISTANCE: HORIZONTAL AT 3 M

NO.	FREQ. (MHz)	EMISSION LEVEL (dBuV/m)	LIMIT (dBuV/m)	MARGIN (dB)	ANTENNA HEIGHT (m)	TABLE ANGLE (Degree)	RAW VALUE (dBuV)	CORRECTION FACTOR (dB/m)
1	5140.00	54.3 PK	74.0	-19.7	1.54 H	360	49.33	4.97
2	5140.00	44.3 AV	54.0	-9.7	1.54 H	360	39.33	4.97
3	*5300.00	104.6 PK			1.54 H	360	99.38	5.22
4	*5300.00	94.0 AV			1.54 H	360	88.78	5.22
5	5381.00	59.6 PK	74.0	-14.4	1.54 H	360	54.15	5.45
6	5381.00	47.6 AV	54.0	-6.4	1.54 H	360	42.15	5.45
7	10600.00	49.8 PK	74.0	-24.2	1.72 H	360	33.35	16.45
8	10600.00	36.0 AV	54.0	-18.0	1.72 H	360	19.55	16.45
9	15900.00	49.9 PK	74.0	-24.1	1.46 H	323	33.34	16.56
10	15900.00	36.3 AV	54.0	-17.7	1.46 H	323	19.74	16.56

ANTENNA POLARITY & TEST DISTANCE: VERTICAL AT 3 M

NO.	FREQ. (MHz)	EMISSION LEVEL (dBuV/m)	LIMIT (dBuV/m)	MARGIN (dB)	ANTENNA HEIGHT (m)	TABLE ANGLE (Degree)	RAW VALUE (dBuV)	CORRECTION FACTOR (dB/m)
1	5140.00	56.5 PK	74.0	-17.5	1.77 V	360	51.53	4.97
2	5140.00	46.5 AV	54.0	-7.5	1.77 V	360	41.53	4.97
3	*5300.00	111.9 PK			1.77 V	360	106.68	5.22
4	*5300.00	101.0 AV			1.77 V	360	95.78	5.22
5	5381.00	64.4 PK	74.0	-9.6	1.65 V	342	58.95	5.45
6	5381.00	53.2 AV	54.0	-0.8	1.65 V	342	47.75	5.45
7	10600.00	49.9 PK	74.0	-24.1	2.02 V	325	33.45	16.45
8	10600.00	35.5 AV	54.0	-18.5	2.02 V	325	19.05	16.45
9	15900.00	49.1 PK	74.0	-24.9	1.81 V	325	32.54	16.56
10	15900.00	36.4 AV	54.0	-17.6	1.81 V	325	19.84	16.56

REMARKS:

1. Emission Level(dBuV/m) = Raw Value(dBuV) + Correction Factor(dB/m)
2. Correction Factor(dB/m) = Antenna Factor(dB/m) + Cable Factor(dB) – Pre-Amplifier Factor(dB)
3. The other emission levels were very low against the limit.
4. Margin value = Emission Level – Limit value
5. " * ": Fundamental frequency.

CHANNEL	TX Channel 64	DETECTOR FUNCTION	Peak (PK)
FREQUENCY RANGE	1GHz ~ 40GHz		Average (AV)

ANTENNA POLARITY & TEST DISTANCE: HORIZONTAL AT 3 M

NO.	FREQ. (MHz)	EMISSION LEVEL (dBuV/m)	LIMIT (dBuV/m)	MARGIN (dB)	ANTENNA HEIGHT (m)	TABLE ANGLE (Degree)	RAW VALUE (dBuV)	CORRECTION FACTOR (dB/m)
1	*5320.00	104.4 PK			1.55 H	360	99.12	5.28
2	*5320.00	93.7 AV			1.55 H	360	88.42	5.28
3	5350.00	62.4 PK	74.0	-11.6	1.55 H	360	57.04	5.36
4	5350.00	47.3 AV	54.0	-6.7	1.55 H	360	41.94	5.36
5	5400.00	56.4 PK	74.0	-17.6	1.54 H	356	50.90	5.50
6	5400.00	46.8 AV	54.0	-7.2	1.54 H	356	41.30	5.50
7	10640.00	50.3 PK	74.0	-23.7	1.73 H	360	33.97	16.33
8	10640.00	36.2 AV	54.0	-17.8	1.73 H	360	19.87	16.33
9	15960.00	50.3 PK	74.0	-23.7	1.45 H	327	33.60	16.70
10	15960.00	36.5 AV	54.0	-17.5	1.45 H	327	19.80	16.70

ANTENNA POLARITY & TEST DISTANCE: VERTICAL AT 3 M

NO.	FREQ. (MHz)	EMISSION LEVEL (dBuV/m)	LIMIT (dBuV/m)	MARGIN (dB)	ANTENNA HEIGHT (m)	TABLE ANGLE (Degree)	RAW VALUE (dBuV)	CORRECTION FACTOR (dB/m)
1	*5320.00	112.1 PK			1.74 V	360	106.82	5.28
2	*5320.00	100.3 AV			1.74 V	360	95.02	5.28
3	5350.00	67.7 PK	74.0	-6.3	1.74 V	356	62.34	5.36
4	5350.00	51.4 AV	54.0	-2.6	1.74 V	356	46.04	5.36
5	5400.00	61.8 PK	74.0	-12.2	1.56 V	360	56.30	5.50
6	5400.00	50.4 AV	54.0	-3.6	1.56 V	360	44.90	5.50
7	10640.00	50.3 PK	74.0	-23.7	2.02 V	310	33.97	16.33
8	10640.00	35.9 AV	54.0	-18.1	2.02 V	310	19.57	16.33
9	15960.00	49.3 PK	74.0	-24.7	1.78 V	325	32.60	16.70
10	15960.00	36.4 AV	54.0	-17.6	1.78 V	325	19.70	16.70

REMARKS:

- Emission Level(dBuV/m) = Raw Value(dBuV) + Correction Factor(dB/m)
- Correction Factor(dB/m) = Antenna Factor(dB/m) + Cable Factor(dB) – Pre-Amplifier Factor(dB)
- The other emission levels were very low against the limit.
- Margin value = Emission Level – Limit value
- " * ": Fundamental frequency.

CHANNEL	TX Channel 100	DETECTOR FUNCTION	Peak (PK)
FREQUENCY RANGE	1GHz ~ 40GHz		Average (AV)

ANTENNA POLARITY & TEST DISTANCE: HORIZONTAL AT 3 M

NO.	FREQ. (MHz)	EMISSION LEVEL (dBuV/m)	LIMIT (dBuV/m)	MARGIN (dB)	ANTENNA HEIGHT (m)	TABLE ANGLE (Degree)	RAW VALUE (dBuV)	CORRECTION FACTOR (dB/m)
1	5421.00	57.9 PK	74.0	-16.1	1.56 H	360	52.35	5.55
2	5421.00	47.1 AV	54.0	-6.9	1.56 H	360	41.55	5.55
3	#5470.00	65.4 PK	74.0	-8.6	1.57 H	320	59.76	5.64
4	#5470.00	48.1 AV	54.0	-5.9	1.57 H	320	42.46	5.64
5	*5500.00	105.0 PK			1.57 H	320	99.30	5.70
6	*5500.00	94.5 AV			1.57 H	320	88.80	5.70
7	#5742.00	56.4 PK	74.0	-17.6	1.70 H	356	50.21	6.19
8	#5742.00	45.9 AV	54.0	-8.1	1.70 H	356	39.71	6.19
9	11000.00	49.4 PK	74.0	-24.6	1.71 H	360	32.22	17.18
10	11000.00	35.6 AV	54.0	-18.4	1.71 H	360	18.42	17.18
11	#16500.00	49.3 PK	74.0	-24.7	1.41 H	322	29.76	19.54
12	#16500.00	36.0 AV	54.0	-18.0	1.41 H	322	16.46	19.54

ANTENNA POLARITY & TEST DISTANCE: VERTICAL AT 3 M

NO.	FREQ. (MHz)	EMISSION LEVEL (dBuV/m)	LIMIT (dBuV/m)	MARGIN (dB)	ANTENNA HEIGHT (m)	TABLE ANGLE (Degree)	RAW VALUE (dBuV)	CORRECTION FACTOR (dB/m)
1	5421.00	63.4 PK	74.0	-10.6	1.77 V	360	57.85	5.55
2	5421.00	52.4 AV	54.0	-1.6	1.77 V	360	46.85	5.55
3	#5470.00	70.8 PK	74.0	-3.2	1.77 V	360	65.16	5.64
4	#5470.00	53.3 AV	54.0	-0.7	1.77 V	360	47.66	5.64
5	*5500.00	112.4 PK			1.77 V	360	106.70	5.70
6	*5500.00	101.9 AV			1.77 V	360	96.20	5.70
7	#5742.00	60.8 PK	74.0	-13.2	1.60 V	360	54.61	6.19
8	#5742.00	50.0 AV	54.0	-4.0	1.60 V	360	43.81	6.19
9	11000.00	49.8 PK	74.0	-24.2	2.01 V	313	32.62	17.18
10	11000.00	35.5 AV	54.0	-18.5	2.01 V	313	18.32	17.18
11	#16500.00	49.6 PK	74.0	-24.4	1.77 V	335	30.06	19.54
12	#16500.00	36.6 AV	54.0	-17.4	1.77 V	335	17.06	19.54

REMARKS:

- Emission Level(dBuV/m) = Raw Value(dBuV) + Correction Factor(dB/m)
- Correction Factor(dB/m) = Antenna Factor(dB/m) + Cable Factor(dB) – Pre-Amplifier Factor(dB)
- The other emission levels were very low against the limit.
- Margin value = Emission Level – Limit value
- " * ": Fundamental frequency.
- " # ": The radiated frequency is out of the restricted band.

CHANNEL	TX Channel 116	DETECTOR FUNCTION	Peak (PK)
FREQUENCY RANGE	1GHz ~ 40GHz		Average (AV)

ANTENNA POLARITY & TEST DISTANCE: HORIZONTAL AT 3 M

NO.	FREQ. (MHz)	EMISSION LEVEL (dBuV/m)	LIMIT (dBuV/m)	MARGIN (dB)	ANTENNA HEIGHT (m)	TABLE ANGLE (Degree)	RAW VALUE (dBuV)	CORRECTION FACTOR (dB/m)
1	5421.00	55.9 PK	74.0	-18.1	1.42 H	360	50.35	5.55
2	5421.00	45.9 AV	54.0	-8.1	1.42 H	360	40.35	5.55
3	*5580.00	103.4 PK			1.42 H	360	97.63	5.77
4	*5580.00	92.7 AV			1.42 H	360	86.93	5.77
5	#5739.00	59.3 PK	74.0	-14.7	1.42 H	360	53.12	6.18
6	#5739.00	48.3 AV	54.0	-5.7	1.42 H	360	42.12	6.18
7	11160.00	50.7 PK	74.0	-23.3	1.66 H	344	33.53	17.17
8	11160.00	36.5 AV	54.0	-17.5	1.66 H	344	19.33	17.17
9	#16740.00	51.1 PK	74.0	-22.9	1.46 H	326	31.42	19.68
10	#16740.00	37.3 AV	54.0	-16.7	1.46 H	326	17.62	19.68

ANTENNA POLARITY & TEST DISTANCE: VERTICAL AT 3 M

NO.	FREQ. (MHz)	EMISSION LEVEL (dBuV/m)	LIMIT (dBuV/m)	MARGIN (dB)	ANTENNA HEIGHT (m)	TABLE ANGLE (Degree)	RAW VALUE (dBuV)	CORRECTION FACTOR (dB/m)
1	5421.00	58.1 PK	74.0	-15.9	1.68 V	352	52.55	5.55
2	5421.00	48.0 AV	54.0	-6.0	1.68 V	352	42.45	5.55
3	*5580.00	110.8 PK			1.68 V	350	105.03	5.77
4	*5580.00	100.0 AV			1.68 V	350	94.23	5.77
5	#5739.00	63.9 PK	74.0	-10.1	1.60 V	360	57.72	6.18
6	#5739.00	52.9 AV	54.0	-1.1	1.60 V	360	46.72	6.18
7	11160.00	51.3 PK	74.0	-22.7	2.12 V	305	34.13	17.17
8	11160.00	37.5 AV	54.0	-16.5	2.12 V	305	20.33	17.17
9	#16740.00	51.0 PK	74.0	-23.0	1.77 V	349	31.32	19.68
10	#16740.00	38.4 AV	54.0	-15.6	1.77 V	349	18.72	19.68

REMARKS:

- Emission Level(dBuV/m) = Raw Value(dBuV) + Correction Factor(dB/m)
- Correction Factor(dB/m) = Antenna Factor(dB/m) + Cable Factor(dB) – Pre-Amplifier Factor(dB)
- The other emission levels were very low against the limit.
- Margin value = Emission Level – Limit value
- " * ": Fundamental frequency.
- " # ": The radiated frequency is out of the restricted band.

CHANNEL	TX Channel 140	DETECTOR FUNCTION	Peak (PK)
FREQUENCY RANGE	1GHz ~ 40GHz		Average (AV)

ANTENNA POLARITY & TEST DISTANCE: HORIZONTAL AT 3 M

NO.	FREQ. (MHz)	EMISSION LEVEL (dBuV/m)	LIMIT (dBuV/m)	MARGIN (dB)	ANTENNA HEIGHT (m)	TABLE ANGLE (Degree)	RAW VALUE (dBuV)	CORRECTION FACTOR (dB/m)
1	*5700.00	105.8 PK			1.56 H	360	99.73	6.07
2	*5700.00	94.9 AV			1.56 H	360	88.83	6.07
3	#5725.00	67.0 PK	74.0	-7.0	1.56 H	360	60.86	6.14
4	#5725.00	48.0 AV	54.0	-6.0	1.56 H	360	41.86	6.14
5	#5862.20	58.3 PK	74.0	-15.7	1.56 H	360	51.89	6.41
6	#5862.20	48.3 AV	54.0	-5.7	1.56 H	360	41.89	6.41
7	11400.00	50.9 PK	74.0	-23.1	1.64 H	349	33.73	17.17
8	11400.00	36.9 AV	54.0	-17.1	1.64 H	349	19.73	17.17
9	#17100.00	51.8 PK	74.0	-22.2	1.50 H	320	29.99	21.81
10	#17100.00	37.8 AV	54.0	-16.2	1.50 H	320	15.99	21.81

ANTENNA POLARITY & TEST DISTANCE: VERTICAL AT 3 M

NO.	FREQ. (MHz)	EMISSION LEVEL (dBuV/m)	LIMIT (dBuV/m)	MARGIN (dB)	ANTENNA HEIGHT (m)	TABLE ANGLE (Degree)	RAW VALUE (dBuV)	CORRECTION FACTOR (dB/m)
1	*5700.00	113.2 PK			1.70 V	360	107.13	6.07
2	*5700.00	102.3 AV			1.70 V	360	96.23	6.07
3	#5725.00	71.9 PK	74.0	-2.1	1.70 V	360	65.76	6.14
4	#5725.00	53.4 AV	54.0	-0.6	1.70 V	360	47.26	6.14
5	#5862.20	63.8 PK	74.0	-10.2	1.77 V	346	57.39	6.41
6	#5862.20	53.8 AV	54.0	-0.2	1.77 V	346	47.39	6.41
7	11400.00	51.0 PK	74.0	-23.0	2.08 V	315	33.83	17.17
8	11400.00	37.3 AV	54.0	-16.7	2.08 V	315	20.13	17.17
9	#17100.00	50.7 PK	74.0	-23.3	1.81 V	338	28.89	21.81
10	#17100.00	38.3 AV	54.0	-15.7	1.81 V	338	16.49	21.81

REMARKS:

1. Emission Level(dBuV/m) = Raw Value(dBuV) + Correction Factor(dB/m)
2. Correction Factor(dB/m) = Antenna Factor(dB/m) + Cable Factor(dB) – Pre-Amplifier Factor(dB)
3. The other emission levels were very low against the limit.
4. Margin value = Emission Level – Limit value
5. " * ": Fundamental frequency.
6. " # ": The radiated frequency is out of the restricted band.

802.11ac (VHT40)

CHANNEL	TX Channel 54	DETECTOR FUNCTION	Peak (PK)
FREQUENCY RANGE	1GHz ~ 40GHz		Average (AV)

ANTENNA POLARITY & TEST DISTANCE: HORIZONTAL AT 3 M								
NO.	FREQ. (MHz)	EMISSION LEVEL (dBuV/m)	LIMIT (dBuV/m)	MARGIN (dB)	ANTENNA HEIGHT (m)	TABLE ANGLE (Degree)	RAW VALUE (dBuV)	CORRECTION FACTOR (dB/m)
1	*5270.00	103.5 PK			1.55 H	360	98.34	5.16
2	*5270.00	92.2 AV			1.55 H	360	87.04	5.16
3	5354.00	54.6 PK	74.0	-19.4	1.55 H	360	49.22	5.38
4	5354.00	46.6 AV	54.0	-7.4	1.55 H	360	41.22	5.38
5	#10540.00	51.1 PK	74.0	-22.9	1.72 H	360	34.75	16.35
6	#10540.00	37.0 AV	54.0	-17.0	1.72 H	360	20.65	16.35
7	15810.00	51.6 PK	74.0	-22.4	1.56 H	321	34.69	16.91
8	15810.00	37.9 AV	54.0	-16.1	1.56 H	321	20.99	16.91
ANTENNA POLARITY & TEST DISTANCE: VERTICAL AT 3 M								
NO.	FREQ. (MHz)	EMISSION LEVEL (dBuV/m)	LIMIT (dBuV/m)	MARGIN (dB)	ANTENNA HEIGHT (m)	TABLE ANGLE (Degree)	RAW VALUE (dBuV)	CORRECTION FACTOR (dB/m)
1	*5270.00	110.2 PK			1.72 V	360	105.04	5.16
2	*5270.00	99.0 AV			1.72 V	360	93.84	5.16
3	5354.00	60.6 PK	74.0	-13.4	1.72 V	360	55.22	5.38
4	5354.00	50.0 AV	54.0	-4.0	1.72 V	360	44.62	5.38
5	#10540.00	50.3 PK	74.0	-23.7	2.10 V	313	33.95	16.35
6	#10540.00	36.6 AV	54.0	-17.4	2.10 V	313	20.25	16.35
7	15810.00	51.3 PK	74.0	-22.7	1.77 V	333	34.39	16.91
8	15810.00	38.6 AV	54.0	-15.4	1.77 V	333	21.69	16.91

REMARKS:

- Emission Level(dBuV/m) = Raw Value(dBuV) + Correction Factor(dB/m)
- Correction Factor(dB/m) = Antenna Factor(dB/m) + Cable Factor(dB) – Pre-Amplifier Factor(dB)
- The other emission levels were very low against the limit.
- Margin value = Emission Level – Limit value
- " * ": Fundamental frequency.
- " # ": The radiated frequency is out of the restricted band.



CHANNEL	TX Channel 62	DETECTOR FUNCTION	Peak (PK)
FREQUENCY RANGE	1GHz ~ 40GHz		Average (AV)

ANTENNA POLARITY & TEST DISTANCE: HORIZONTAL AT 3 M

NO.	FREQ. (MHz)	EMISSION LEVEL (dBuV/m)	LIMIT (dBuV/m)	MARGIN (dB)	ANTENNA HEIGHT (m)	TABLE ANGLE (Degree)	RAW VALUE (dBuV)	CORRECTION FACTOR (dB/m)
1	*5310.00	98.8 PK			1.56 H	360	93.55	5.25
2	*5310.00	88.2 AV			1.56 H	360	82.95	5.25
3	5350.00	68.4 PK	74.0	-5.6	1.56 H	360	63.04	5.36
4	5350.00	49.6 AV	54.0	-4.4	1.56 H	360	44.24	5.36
5	10620.00	51.5 PK	74.0	-22.5	1.66 H	360	35.11	16.39
6	10620.00	37.3 AV	54.0	-16.7	1.66 H	360	20.91	16.39
7	15930.00	51.7 PK	74.0	-22.3	1.55 H	314	35.06	16.64
8	15930.00	37.7 AV	54.0	-16.3	1.55 H	314	21.06	16.64

ANTENNA POLARITY & TEST DISTANCE: VERTICAL AT 3 M

NO.	FREQ. (MHz)	EMISSION LEVEL (dBuV/m)	LIMIT (dBuV/m)	MARGIN (dB)	ANTENNA HEIGHT (m)	TABLE ANGLE (Degree)	RAW VALUE (dBuV)	CORRECTION FACTOR (dB/m)
1	*5310.00	106.2 PK			1.77 V	360	100.95	5.25
2	*5310.00	95.4 AV			1.77 V	360	90.15	5.25
3	5350.00	70.3 PK	74.0	-3.7	1.77 V	360	64.94	5.36
4	5350.00	53.4 AV	54.0	-0.6	1.77 V	360	48.04	5.36
5	10620.00	50.6 PK	74.0	-23.4	2.08 V	328	34.21	16.39
6	10620.00	36.6 AV	54.0	-17.4	2.08 V	328	20.21	16.39
7	15930.00	51.6 PK	74.0	-22.4	1.73 V	312	34.96	16.64
8	15930.00	38.5 AV	54.0	-15.5	1.73 V	312	21.86	16.64

REMARKS:

1. Emission Level(dBuV/m) = Raw Value(dBuV) + Correction Factor(dB/m)
2. Correction Factor(dB/m) = Antenna Factor(dB/m) + Cable Factor(dB) – Pre-Amplifier Factor(dB)
3. The other emission levels were very low against the limit.
4. Margin value = Emission Level – Limit value
5. " * ": Fundamental frequency.

CHANNEL	TX Channel 102	DETECTOR FUNCTION	Peak (PK)
FREQUENCY RANGE	1GHz ~ 40GHz		Average (AV)

ANTENNA POLARITY & TEST DISTANCE: HORIZONTAL AT 3 M

NO.	FREQ. (MHz)	EMISSION LEVEL (dBuV/m)	LIMIT (dBuV/m)	MARGIN (dB)	ANTENNA HEIGHT (m)	TABLE ANGLE (Degree)	RAW VALUE (dBuV)	CORRECTION FACTOR (dB/m)
1	#5470.00	64.2 PK	74.0	-9.8	1.59 H	326	58.56	5.64
2	#5470.00	48.0 AV	54.0	-6.0	1.59 H	326	42.36	5.64
3	*5510.00	101.2 PK			1.59 H	326	95.49	5.71
4	*5510.00	89.2 AV			1.59 H	326	83.49	5.71
5	11020.00	51.8 PK	74.0	-22.2	1.64 H	360	34.53	17.27
6	11020.00	37.5 AV	54.0	-16.5	1.64 H	360	20.23	17.27
7	#16530.00	51.6 PK	74.0	-22.4	1.50 H	317	32.05	19.55
8	#16530.00	37.8 AV	54.0	-16.2	1.50 H	317	18.25	19.55

ANTENNA POLARITY & TEST DISTANCE: VERTICAL AT 3 M

NO.	FREQ. (MHz)	EMISSION LEVEL (dBuV/m)	LIMIT (dBuV/m)	MARGIN (dB)	ANTENNA HEIGHT (m)	TABLE ANGLE (Degree)	RAW VALUE (dBuV)	CORRECTION FACTOR (dB/m)
1	#5470.00	69.0 PK	74.0	-5.0	1.74 V	360	63.36	5.64
2	#5470.00	53.4 AV	54.0	-0.6	1.74 V	360	47.76	5.64
3	*5510.00	107.4 PK			1.74 V	360	101.69	5.71
4	*5510.00	96.4 AV			1.74 V	360	90.69	5.71
5	11020.00	51.2 PK	74.0	-22.8	2.17 V	320	33.93	17.27
6	11020.00	37.0 AV	54.0	-17.0	2.17 V	320	19.73	17.27
7	#16530.00	51.7 PK	74.0	-22.3	1.84 V	330	32.15	19.55
8	#16530.00	38.7 AV	54.0	-15.3	1.84 V	330	19.15	19.55

REMARKS:

1. Emission Level(dBuV/m) = Raw Value(dBuV) + Correction Factor(dB/m)
2. Correction Factor(dB/m) = Antenna Factor(dB/m) + Cable Factor(dB) – Pre-Amplifier Factor(dB)
3. The other emission levels were very low against the limit.
4. Margin value = Emission Level – Limit value
5. " * ": Fundamental frequency.
6. " # ": The radiated frequency is out of the restricted band.

CHANNEL	TX Channel 110	DETECTOR FUNCTION	Peak (PK)
FREQUENCY RANGE	1GHz ~ 40GHz		Average (AV)

ANTENNA POLARITY & TEST DISTANCE: HORIZONTAL AT 3 M

NO.	FREQ. (MHz)	EMISSION LEVEL (dBuV/m)	LIMIT (dBuV/m)	MARGIN (dB)	ANTENNA HEIGHT (m)	TABLE ANGLE (Degree)	RAW VALUE (dBuV)	CORRECTION FACTOR (dB/m)
1	#5470.00	64.4 PK	74.0	-9.6	1.55 H	360	58.76	5.64
2	#5470.00	48.2 AV	54.0	-5.8	1.55 H	360	42.56	5.64
3	*5550.00	109.1 PK			1.55 H	360	103.36	5.74
4	*5550.00	97.8 AV			1.55 H	360	92.06	5.74
5	#5727.00	57.7 PK	74.0	-16.3	1.55 H	360	51.55	6.15
6	#5727.00	45.6 AV	54.0	-8.4	1.55 H	360	39.45	6.15
7	11100.00	51.8 PK	74.0	-22.2	1.68 H	360	34.15	17.65
8	11100.00	37.5 AV	54.0	-16.5	1.68 H	360	19.85	17.65
9	#16650.00	52.0 PK	74.0	-22.0	1.48 H	329	32.43	19.57
10	#16650.00	38.3 AV	54.0	-15.7	1.48 H	329	18.73	19.57

ANTENNA POLARITY & TEST DISTANCE: VERTICAL AT 3 M

NO.	FREQ. (MHz)	EMISSION LEVEL (dBuV/m)	LIMIT (dBuV/m)	MARGIN (dB)	ANTENNA HEIGHT (m)	TABLE ANGLE (Degree)	RAW VALUE (dBuV)	CORRECTION FACTOR (dB/m)
1	#5470.00	69.4 PK	74.0	-4.6	1.66 V	354	63.76	5.64
2	#5470.00	53.6 AV	54.0	-0.4	1.66 V	354	47.96	5.64
3	*5550.00	113.6 PK			1.66 V	354	107.86	5.74
4	*5550.00	102.4 AV			1.66 V	354	96.66	5.74
5	#5727.00	62.3 PK	74.0	-11.7	1.66 V	354	56.15	6.15
6	#5727.00	50.4 AV	54.0	-3.6	1.66 V	354	44.25	6.15
7	11100.00	51.7 PK	74.0	-22.3	2.04 V	313	34.05	17.65
8	11100.00	37.4 AV	54.0	-16.6	2.04 V	313	19.75	17.65
9	#16650.00	50.5 PK	74.0	-23.5	1.85 V	333	30.93	19.57
10	#16650.00	37.9 AV	54.0	-16.1	1.85 V	333	18.33	19.57

REMARKS:

1. Emission Level(dBuV/m) = Raw Value(dBuV) + Correction Factor(dB/m)
2. Correction Factor(dB/m) = Antenna Factor(dB/m) + Cable Factor(dB) – Pre-Amplifier Factor(dB)
3. The other emission levels were very low against the limit.
4. Margin value = Emission Level – Limit value
5. " * ": Fundamental frequency.
6. " # ": The radiated frequency is out of the restricted band.



CHANNEL	TX Channel 134	DETECTOR FUNCTION	Peak (PK)
FREQUENCY RANGE	1GHz ~ 40GHz		Average (AV)

ANTENNA POLARITY & TEST DISTANCE: HORIZONTAL AT 3 M

NO.	FREQ. (MHz)	EMISSION LEVEL (dBuV/m)	LIMIT (dBuV/m)	MARGIN (dB)	ANTENNA HEIGHT (m)	TABLE ANGLE (Degree)	RAW VALUE (dBuV)	CORRECTION FACTOR (dB/m)
1	*5670.00	106.1 PK			1.54 H	360	100.13	5.97
2	*5670.00	94.2 AV			1.54 H	360	88.23	5.97
3	#5744.50	64.4 PK	74.0	-9.6	1.54 H	360	58.21	6.19
4	#5744.50	48.4 AV	54.0	-5.6	1.54 H	360	42.21	6.19
5	11340.00	52.3 PK	74.0	-21.7	1.61 H	349	35.07	17.23
6	11340.00	37.9 AV	54.0	-16.1	1.61 H	349	20.67	17.23
7	#17010.00	51.9 PK	74.0	-22.1	1.56 H	331	30.26	21.64
8	#17010.00	38.3 AV	54.0	-15.7	1.56 H	331	16.66	21.64

ANTENNA POLARITY & TEST DISTANCE: VERTICAL AT 3 M

NO.	FREQ. (MHz)	EMISSION LEVEL (dBuV/m)	LIMIT (dBuV/m)	MARGIN (dB)	ANTENNA HEIGHT (m)	TABLE ANGLE (Degree)	RAW VALUE (dBuV)	CORRECTION FACTOR (dB/m)
1	*5670.00	111.4 PK			1.77 V	360	105.43	5.97
2	*5670.00	99.2 AV			1.77 V	360	93.23	5.97
3	#5744.50	69.2 PK	74.0	-4.8	1.77 V	360	63.01	6.19
4	#5744.50	53.6 AV	54.0	-0.4	1.77 V	360	47.41	6.19
5	11340.00	51.2 PK	74.0	-22.8	2.04 V	315	33.97	17.23
6	11340.00	37.3 AV	54.0	-16.7	2.04 V	315	20.07	17.23
7	#17010.00	51.3 PK	74.0	-22.7	1.80 V	334	29.66	21.64
8	#17010.00	38.5 AV	54.0	-15.5	1.80 V	334	16.86	21.64

REMARKS:

1. Emission Level(dBuV/m) = Raw Value(dBuV) + Correction Factor(dB/m)
2. Correction Factor(dB/m) = Antenna Factor(dB/m) + Cable Factor(dB) – Pre-Amplifier Factor(dB)
3. The other emission levels were very low against the limit.
4. Margin value = Emission Level – Limit value
5. " * ": Fundamental frequency.
6. " # ": The radiated frequency is out of the restricted band.



802.11ac (VHT80)

CHANNEL	TX Channel 58	DETECTOR FUNCTION	Peak (PK)
FREQUENCY RANGE	1GHz ~ 40GHz		Average (AV)

ANTENNA POLARITY & TEST DISTANCE: HORIZONTAL AT 3 M								
NO.	FREQ. (MHz)	EMISSION LEVEL (dBuV/m)	LIMIT (dBuV/m)	MARGIN (dB)	ANTENNA HEIGHT (m)	TABLE ANGLE (Degree)	RAW VALUE (dBuV)	CORRECTION FACTOR (dB/m)
1	5150.00	63.2 PK	74.0	-10.8	1.55 H	342	58.23	4.97
2	5150.00	47.4 AV	54.0	-6.6	1.55 H	342	42.43	4.97
3	*5290.00	95.6 PK			1.55 H	342	90.40	5.20
4	*5290.00	83.4 AV			1.55 H	342	78.20	5.20
5	5358.00	65.0 PK	74.0	-9.0	1.55 H	342	59.61	5.39
6	5358.00	48.2 AV	54.0	-5.8	1.55 H	342	42.81	5.39
7	#10580.00	51.8 PK	74.0	-22.2	1.63 H	356	35.39	16.41
8	#10580.00	37.9 AV	54.0	-16.1	1.63 H	356	21.49	16.41
9	15870.00	52.0 PK	74.0	-22.0	1.49 H	322	35.32	16.68
10	15870.00	38.4 AV	54.0	-15.6	1.49 H	322	21.72	16.68

ANTENNA POLARITY & TEST DISTANCE: VERTICAL AT 3 M								
NO.	FREQ. (MHz)	EMISSION LEVEL (dBuV/m)	LIMIT (dBuV/m)	MARGIN (dB)	ANTENNA HEIGHT (m)	TABLE ANGLE (Degree)	RAW VALUE (dBuV)	CORRECTION FACTOR (dB/m)
1	5150.00	68.6 PK	74.0	-5.4	1.76 V	360	63.63	4.97
2	5150.00	52.4 AV	54.0	-1.6	1.76 V	360	47.43	4.97
3	*5290.00	103.0 PK			1.76 V	360	97.80	5.20
4	*5290.00	90.6 AV			1.76 V	360	85.40	5.20
5	5358.00	70.2 PK	74.0	-3.8	1.76 V	360	64.81	5.39
6	5358.00	53.6 AV	54.0	-0.4	1.76 V	360	48.21	5.39
7	#10580.00	51.2 PK	74.0	-22.8	2.11 V	298	34.79	16.41
8	#10580.00	37.1 AV	54.0	-16.9	2.11 V	298	20.69	16.41
9	15870.00	50.8 PK	74.0	-23.2	1.83 V	320	34.12	16.68
10	15870.00	37.5 AV	54.0	-16.5	1.83 V	320	20.82	16.68

REMARKS:

1. Emission Level(dBuV/m) = Raw Value(dBuV) + Correction Factor(dB/m)
2. Correction Factor(dB/m) = Antenna Factor(dB/m) + Cable Factor(dB) – Pre-Amplifier Factor(dB)
3. The other emission levels were very low against the limit.
4. Margin value = Emission Level – Limit value
5. " * ": Fundamental frequency.
6. " # ": The radiated frequency is out of the restricted band.

CHANNEL	TX Channel 106	DETECTOR FUNCTION	Peak (PK)
FREQUENCY RANGE	1GHz ~ 40GHz		Average (AV)

ANTENNA POLARITY & TEST DISTANCE: HORIZONTAL AT 3 M

NO.	FREQ. (MHz)	EMISSION LEVEL (dBuV/m)	LIMIT (dBuV/m)	MARGIN (dB)	ANTENNA HEIGHT (m)	TABLE ANGLE (Degree)	RAW VALUE (dBuV)	CORRECTION FACTOR (dB/m)
1	5458.00	64.1 PK	74.0	-9.9	1.56 H	340	58.48	5.62
2	5458.00	48.1 AV	54.0	-5.9	1.56 H	340	42.48	5.62
3	*5530.00	94.7 PK			1.56 H	340	88.98	5.72
4	*5530.00	82.6 AV			1.56 H	340	76.88	5.72
5	#5725.00	64.4 PK	74.0	-9.6	1.56 H	340	58.26	6.14
6	#5725.00	46.4 AV	54.0	-7.6	1.56 H	340	40.26	6.14
7	11060.00	52.1 PK	74.0	-21.9	1.63 H	360	34.64	17.46
8	11060.00	38.1 AV	54.0	-15.9	1.63 H	360	20.64	17.46
9	#16590.00	51.7 PK	74.0	-22.3	1.48 H	325	32.14	19.56
10	#16590.00	38.1 AV	54.0	-15.9	1.48 H	325	18.54	19.56

ANTENNA POLARITY & TEST DISTANCE: VERTICAL AT 3 M

NO.	FREQ. (MHz)	EMISSION LEVEL (dBuV/m)	LIMIT (dBuV/m)	MARGIN (dB)	ANTENNA HEIGHT (m)	TABLE ANGLE (Degree)	RAW VALUE (dBuV)	CORRECTION FACTOR (dB/m)
1	5458.00	69.5 PK	74.0	-4.5	1.77 V	360	63.88	5.62
2	5458.00	53.5 AV	54.0	-0.5	1.77 V	360	47.88	5.62
3	*5530.00	102.2 PK			1.77 V	360	96.48	5.72
4	*5530.00	90.2 AV			1.77 V	360	84.48	5.72
5	#5725.00	69.4 PK	74.0	-4.6	1.77 V	360	63.26	6.14
6	#5725.00	51.4 AV	54.0	-2.6	1.77 V	360	45.26	6.14
7	11060.00	51.5 PK	74.0	-22.5	2.16 V	309	34.04	17.46
8	11060.00	37.5 AV	54.0	-16.5	2.16 V	309	20.04	17.46
9	#16590.00	50.7 PK	74.0	-23.3	1.81 V	328	31.14	19.56
10	#16590.00	37.7 AV	54.0	-16.3	1.81 V	328	18.14	19.56

REMARKS:

1. Emission Level(dBuV/m) = Raw Value(dBuV) + Correction Factor(dB/m)
2. Correction Factor(dB/m) = Antenna Factor(dB/m) + Cable Factor(dB) – Pre-Amplifier Factor(dB)
3. The other emission levels were very low against the limit.
4. Margin value = Emission Level – Limit value
5. " * ": Fundamental frequency.
6. " # ": The radiated frequency is out of the restricted band.

CHANNEL	TX Channel 122	DETECTOR FUNCTION	Peak (PK)
FREQUENCY RANGE	1GHz ~ 40GHz		Average (AV)

ANTENNA POLARITY & TEST DISTANCE: HORIZONTAL AT 3 M

NO.	FREQ. (MHz)	EMISSION LEVEL (dBuV/m)	LIMIT (dBuV/m)	MARGIN (dB)	ANTENNA HEIGHT (m)	TABLE ANGLE (Degree)	RAW VALUE (dBuV)	CORRECTION FACTOR (dB/m)
1	#5463.00	62.2 PK	74.0	-11.8	1.44 H	356	56.57	5.63
2	#5463.00	48.2 AV	54.0	-5.8	1.44 H	356	42.57	5.63
3	*5610.00	103.2 PK			1.44 H	356	97.39	5.81
4	*5610.00	90.0 AV			1.44 H	356	84.19	5.81
5	#5744.00	63.4 PK	74.0	-10.6	1.44 H	356	57.21	6.19
6	#5744.00	48.4 AV	54.0	-5.6	1.44 H	356	42.21	6.19
7	11220.00	51.9 PK	74.0	-22.1	1.67 H	360	34.97	16.93
8	11220.00	37.8 AV	54.0	-16.2	1.67 H	360	20.87	16.93
9	#16830.00	51.5 PK	74.0	-22.5	1.55 H	311	31.48	20.02
10	#16830.00	38.0 AV	54.0	-16.0	1.55 H	311	17.98	20.02

ANTENNA POLARITY & TEST DISTANCE: VERTICAL AT 3 M

NO.	FREQ. (MHz)	EMISSION LEVEL (dBuV/m)	LIMIT (dBuV/m)	MARGIN (dB)	ANTENNA HEIGHT (m)	TABLE ANGLE (Degree)	RAW VALUE (dBuV)	CORRECTION FACTOR (dB/m)
1	#5463.00	67.6 PK	74.0	-6.4	1.75 V	360	61.97	5.63
2	#5463.00	53.4 AV	54.0	-0.6	1.75 V	360	47.77	5.63
3	*5610.00	110.4 PK			1.75 V	360	104.59	5.81
4	*5610.00	97.2 AV			1.75 V	360	91.39	5.81
5	#5744.00	68.8 PK	74.0	-5.2	1.75 V	360	62.61	6.19
6	#5744.00	53.8 AV	54.0	-0.2	1.75 V	360	47.61	6.19
7	11220.00	51.6 PK	74.0	-22.4	2.12 V	309	34.67	16.93
8	11220.00	37.6 AV	54.0	-16.4	2.12 V	309	20.67	16.93
9	#16830.00	51.1 PK	74.0	-22.9	1.81 V	326	31.08	20.02
10	#16830.00	37.5 AV	54.0	-16.5	1.81 V	326	17.48	20.02

REMARKS:

1. Emission Level(dBuV/m) = Raw Value(dBuV) + Correction Factor(dB/m)
2. Correction Factor(dB/m) = Antenna Factor(dB/m) + Cable Factor(dB) – Pre-Amplifier Factor(dB)
3. The other emission levels were very low against the limit.
4. Margin value = Emission Level – Limit value
5. " * ": Fundamental frequency.
6. " # ": The radiated frequency is out of the restricted band.

Below 1GHz Data
CDD Mode
802.11ac (VHT40)

CHANNEL	TX Channel 54	DETECTOR FUNCTION	Quasi-Peak (QP)
FREQUENCY RANGE	Below 1GHz		

ANTENNA POLARITY & TEST DISTANCE: HORIZONTAL AT 3 M								
NO.	FREQ. (MHz)	EMISSION LEVEL (dBuV/m)	LIMIT (dBuV/m)	MARGIN (dB)	ANTENNA HEIGHT (m)	TABLE ANGLE (Degree)	RAW VALUE (dBuV)	CORRECTION FACTOR (dB/m)
1	165.99	35.4 QP	43.5	-8.1	1.50 H	227	48.70	-13.32
2	218.58	32.5 QP	46.0	-13.5	1.50 H	261	48.28	-15.79
3	327.85	33.6 QP	46.0	-12.4	1.00 H	233	44.76	-11.14
4	500.01	31.3 QP	46.0	-14.7	1.50 H	148	38.09	-6.83
5	608.81	35.4 QP	46.0	-10.6	1.00 H	226	39.35	-3.93
6	713.61	35.6 QP	46.0	-10.4	1.00 H	255	38.21	-2.63
ANTENNA POLARITY & TEST DISTANCE: VERTICAL AT 3 M								
NO.	FREQ. (MHz)	EMISSION LEVEL (dBuV/m)	LIMIT (dBuV/m)	MARGIN (dB)	ANTENNA HEIGHT (m)	TABLE ANGLE (Degree)	RAW VALUE (dBuV)	CORRECTION FACTOR (dB/m)
1	60.47	34.2 QP	40.0	-5.8	1.38 V	224	47.94	-13.72
2	93.82	37.6 QP	43.5	-5.9	1.55 V	278	55.94	-18.38
3	237.43	31.1 QP	46.0	-14.9	1.53 V	264	45.75	-14.64
4	320.27	32.6 QP	46.0	-13.4	1.50 V	287	43.99	-11.35
5	418.80	32.3 QP	46.0	-13.7	1.26 V	55	41.03	-8.77
6	566.28	32.6 QP	46.0	-13.4	1.55 V	271	38.25	-5.61

REMARKS:

1. Emission Level(dBuV/m) = Raw Value(dBuV) + Correction Factor(dB/m)
2. Correction Factor(dB/m) = Antenna Factor(dB/m) + Cable Factor(dB) – Pre-Amplifier Factor(dB)
3. The other emission levels were very low against the limit.
4. Margin value = Emission Level – Limit value

4.1.8 Test Results (Mode 2)

Above 1GHz Data

CDD Mode

802.11a

CHANNEL	TX Channel 52	DETECTOR FUNCTION	Peak (PK)
FREQUENCY RANGE	1GHz ~ 40GHz		Average (AV)

ANTENNA POLARITY & TEST DISTANCE: HORIZONTAL AT 3 M								
NO.	FREQ. (MHz)	EMISSION LEVEL (dBuV/m)	LIMIT (dBuV/m)	MARGIN (dB)	ANTENNA HEIGHT (m)	TABLE ANGLE (Degree)	RAW VALUE (dBuV)	CORRECTION FACTOR (dB/m)
1	5150.00	60.6 PK	74.0	-13.4	1.37 H	360	55.63	4.97
2	5150.00	49.5 AV	54.0	-4.5	1.37 H	360	44.53	4.97
3	*5260.00	111.2 PK			1.37 H	360	106.05	5.15
4	*5260.00	100.9 AV			1.37 H	360	95.75	5.15
5	5418.00	61.5 PK	74.0	-12.5	2.08 H	360	55.95	5.55
6	5418.00	51.4 AV	54.0	-2.6	2.08 H	360	45.85	5.55
7	#5498.00	58.8 PK	74.0	-15.2	1.97 H	295	53.10	5.70
8	#5498.00	47.5 AV	54.0	-6.5	1.97 H	295	41.80	5.70
9	#10520.00	50.7 PK	74.0	-23.3	1.58 H	360	34.38	16.32
10	#10520.00	37.0 AV	54.0	-17.0	1.58 H	360	20.68	16.32
11	15780.00	51.9 PK	74.0	-22.1	1.45 H	332	34.80	17.10
12	15780.00	38.1 AV	54.0	-15.9	1.45 H	332	21.00	17.10

ANTENNA POLARITY & TEST DISTANCE: VERTICAL AT 3 M								
NO.	FREQ. (MHz)	EMISSION LEVEL (dBuV/m)	LIMIT (dBuV/m)	MARGIN (dB)	ANTENNA HEIGHT (m)	TABLE ANGLE (Degree)	RAW VALUE (dBuV)	CORRECTION FACTOR (dB/m)
1	5150.00	62.4 PK	74.0	-11.6	1.41 V	353	57.43	4.97
2	5150.00	51.4 AV	54.0	-2.6	1.41 V	353	46.43	4.97
3	*5260.00	112.5 PK			1.41 V	353	107.35	5.15
4	*5260.00	101.8 AV			1.41 V	353	96.65	5.15
5	5418.00	64.9 PK	74.0	-9.1	1.41 V	355	59.35	5.55
6	5418.00	53.9 AV	54.0	-0.1	1.41 V	355	48.35	5.55
7	#5498.00	61.1 PK	74.0	-12.9	1.32 V	353	55.40	5.70
8	#5498.00	50.1 AV	54.0	-3.9	1.32 V	353	44.40	5.70
9	#10520.00	50.5 PK	74.0	-23.5	2.07 V	320	34.18	16.32
10	#10520.00	36.8 AV	54.0	-17.2	2.07 V	320	20.48	16.32
11	15780.00	51.4 PK	74.0	-22.6	1.79 V	356	34.30	17.10
12	15780.00	38.5 AV	54.0	-15.5	1.79 V	356	21.40	17.10

REMARKS:

1. Emission Level(dBuV/m) = Raw Value(dBuV) + Correction Factor(dB/m)
2. Correction Factor(dB/m) = Antenna Factor(dB/m) + Cable Factor(dB) – Pre-Amplifier Factor(dB)
3. The other emission levels were very low against the limit.
4. Margin value = Emission Level – Limit value
5. " * ": Fundamental frequency.
6. " # ": The radiated frequency is out of the restricted band.



CHANNEL	TX Channel 60	DETECTOR FUNCTION	Peak (PK)
FREQUENCY RANGE	1GHz ~ 40GHz		Average (AV)

ANTENNA POLARITY & TEST DISTANCE: HORIZONTAL AT 3 M

NO.	FREQ. (MHz)	EMISSION LEVEL (dBuV/m)	LIMIT (dBuV/m)	MARGIN (dB)	ANTENNA HEIGHT (m)	TABLE ANGLE (Degree)	RAW VALUE (dBuV)	CORRECTION FACTOR (dB/m)
1	*5300.00	110.0 PK			1.42 H	360	104.78	5.22
2	*5300.00	99.1 AV			1.42 H	360	93.88	5.22
3	5458.00	62.6 PK	74.0	-11.4	1.42 H	360	56.98	5.62
4	5458.00	52.5 AV	54.0	-1.5	1.42 H	360	46.88	5.62
5	10600.00	50.6 PK	74.0	-23.4	1.64 H	359	34.15	16.45
6	10600.00	37.0 AV	54.0	-17.0	1.64 H	359	20.55	16.45
7	15900.00	51.3 PK	74.0	-22.7	1.40 H	323	34.74	16.56
8	15900.00	37.7 AV	54.0	-16.3	1.40 H	323	21.14	16.56

ANTENNA POLARITY & TEST DISTANCE: VERTICAL AT 3 M

NO.	FREQ. (MHz)	EMISSION LEVEL (dBuV/m)	LIMIT (dBuV/m)	MARGIN (dB)	ANTENNA HEIGHT (m)	TABLE ANGLE (Degree)	RAW VALUE (dBuV)	CORRECTION FACTOR (dB/m)
1	*5300.00	111.9 PK			1.48 V	357	106.68	5.22
2	*5300.00	101.2 AV			1.48 V	357	95.98	5.22
3	5458.00	64.0 PK	74.0	-10.0	1.60 V	0	58.38	5.62
4	5458.00	53.9 AV	54.0	-0.1	1.60 V	0	48.28	5.62
5	10600.00	50.4 PK	74.0	-23.6	2.08 V	311	33.95	16.45
6	10600.00	36.7 AV	54.0	-17.3	2.08 V	311	20.25	16.45
7	15900.00	51.5 PK	74.0	-22.5	1.83 V	342	34.94	16.56
8	15900.00	38.7 AV	54.0	-15.3	1.83 V	342	22.14	16.56

REMARKS:

1. Emission Level(dBuV/m) = Raw Value(dBuV) + Correction Factor(dB/m)
2. Correction Factor(dB/m) = Antenna Factor(dB/m) + Cable Factor(dB) – Pre-Amplifier Factor(dB)
3. The other emission levels were very low against the limit.
4. Margin value = Emission Level – Limit value
5. " * ": Fundamental frequency.

CHANNEL	TX Channel 64	DETECTOR FUNCTION	Peak (PK)
FREQUENCY RANGE	1GHz ~ 40GHz		Average (AV)

ANTENNA POLARITY & TEST DISTANCE: HORIZONTAL AT 3 M

NO.	FREQ. (MHz)	EMISSION LEVEL (dBuV/m)	LIMIT (dBuV/m)	MARGIN (dB)	ANTENNA HEIGHT (m)	TABLE ANGLE (Degree)	RAW VALUE (dBuV)	CORRECTION FACTOR (dB/m)
1	*5320.00	110.4 PK			1.38 H	360	105.12	5.28
2	*5320.00	100.9 AV			1.38 H	360	95.62	5.28
3	5350.00	66.4 PK	74.0	-7.6	1.38 H	360	61.04	5.36
4	5350.00	50.4 AV	54.0	-3.6	1.38 H	360	45.04	5.36
5	5398.30	62.2 PK	74.0	-11.8	1.38 H	360	56.70	5.50
6	5398.30	52.6 AV	54.0	-1.4	1.38 H	360	47.10	5.50
7	10640.00	49.2 PK	74.0	-24.8	1.62 H	360	32.87	16.33
8	10640.00	36.4 AV	54.0	-17.6	1.62 H	360	20.07	16.33
9	15960.00	51.4 PK	74.0	-22.6	1.50 H	319	34.70	16.70
10	15960.00	37.5 AV	54.0	-16.5	1.50 H	319	20.80	16.70

ANTENNA POLARITY & TEST DISTANCE: VERTICAL AT 3 M

NO.	FREQ. (MHz)	EMISSION LEVEL (dBuV/m)	LIMIT (dBuV/m)	MARGIN (dB)	ANTENNA HEIGHT (m)	TABLE ANGLE (Degree)	RAW VALUE (dBuV)	CORRECTION FACTOR (dB/m)
1	*5320.00	112.3 PK			1.58 V	1	107.02	5.28
2	*5320.00	103.0 AV			1.58 V	1	97.72	5.28
3	5350.00	67.6 PK	74.0	-6.4	1.58 V	1	62.24	5.36
4	5350.00	51.9 AV	54.0	-2.1	1.58 V	1	46.54	5.36
5	5398.30	63.9 PK	74.0	-10.1	1.48 V	1	58.40	5.50
6	5398.30	53.9 AV	54.0	-0.1	1.48 V	1	48.40	5.50
7	10640.00	49.7 PK	74.0	-24.3	2.05 V	316	33.37	16.33
8	10640.00	36.2 AV	54.0	-17.8	2.05 V	316	19.87	16.33
9	15960.00	49.1 PK	74.0	-24.9	1.74 V	355	32.40	16.70
10	15960.00	36.1 AV	54.0	-17.9	1.74 V	355	19.40	16.70

REMARKS:

1. Emission Level(dBuV/m) = Raw Value(dBuV) + Correction Factor(dB/m)
2. Correction Factor(dB/m) = Antenna Factor(dB/m) + Cable Factor(dB) – Pre-Amplifier Factor(dB)
3. The other emission levels were very low against the limit.
4. Margin value = Emission Level – Limit value
5. " * ": Fundamental frequency.



CHANNEL	TX Channel 100	DETECTOR FUNCTION	Peak (PK)
FREQUENCY RANGE	1GHz ~ 40GHz		Average (AV)

ANTENNA POLARITY & TEST DISTANCE: HORIZONTAL AT 3 M

NO.	FREQ. (MHz)	EMISSION LEVEL (dBuV/m)	LIMIT (dBuV/m)	MARGIN (dB)	ANTENNA HEIGHT (m)	TABLE ANGLE (Degree)	RAW VALUE (dBuV)	CORRECTION FACTOR (dB/m)
1	5418.00	59.9 PK	74.0	-14.1	1.69 H	360	54.35	5.55
2	5418.00	50.1 AV	54.0	-3.9	1.69 H	360	44.55	5.55
3	#5470.00	67.9 PK	74.0	-6.1	1.69 H	311	62.26	5.64
4	#5470.00	46.7 AV	54.0	-7.3	1.69 H	311	41.06	5.64
5	*5500.00	112.1 PK			1.66 H	311	106.40	5.70
6	*5500.00	101.5 AV			1.66 H	311	95.80	5.70
7	#5738.00	61.6 PK	74.0	-12.4	1.69 H	301	55.42	6.18
8	#5738.00	50.9 AV	54.0	-3.1	1.69 H	301	44.72	6.18
9	11000.00	50.9 PK	74.0	-23.1	1.55 H	360	33.72	17.18
10	11000.00	37.1 AV	54.0	-16.9	1.55 H	360	19.92	17.18
11	#16500.00	51.9 PK	74.0	-22.1	1.39 H	341	32.36	19.54
12	#16500.00	38.2 AV	54.0	-15.8	1.39 H	341	18.66	19.54

ANTENNA POLARITY & TEST DISTANCE: VERTICAL AT 3 M

NO.	FREQ. (MHz)	EMISSION LEVEL (dBuV/m)	LIMIT (dBuV/m)	MARGIN (dB)	ANTENNA HEIGHT (m)	TABLE ANGLE (Degree)	RAW VALUE (dBuV)	CORRECTION FACTOR (dB/m)
1	5418.00	64.2 PK	74.0	-9.8	1.31 V	356	58.65	5.55
2	5418.00	53.9 AV	54.0	-0.1	1.31 V	356	48.35	5.55
3	#5470.00	69.4 PK	74.0	-4.6	1.49 V	354	63.76	5.64
4	#5470.00	49.0 AV	54.0	-5.0	1.49 V	354	43.36	5.64
5	*5500.00	115.1 PK			1.49 V	354	109.40	5.70
6	*5500.00	104.3 AV			1.49 V	354	98.60	5.70
7	#5738.00	63.3 PK	74.0	-10.7	1.60 V	360	57.12	6.18
8	#5738.00	52.7 AV	54.0	-1.3	1.60 V	360	46.52	6.18
9	11000.00	50.8 PK	74.0	-23.2	2.06 V	333	33.62	17.18
10	11000.00	37.1 AV	54.0	-16.9	2.06 V	333	19.92	17.18
11	#16500.00	50.9 PK	74.0	-23.1	1.84 V	356	31.36	19.54
12	#16500.00	38.3 AV	54.0	-15.7	1.84 V	356	18.76	19.54

REMARKS:

1. Emission Level(dBuV/m) = Raw Value(dBuV) + Correction Factor(dB/m)
2. Correction Factor(dB/m) = Antenna Factor(dB/m) + Cable Factor(dB) – Pre-Amplifier Factor(dB)
3. The other emission levels were very low against the limit.
4. Margin value = Emission Level – Limit value
5. " * ": Fundamental frequency.
6. " # ": The radiated frequency is out of the restricted band.

CHANNEL	TX Channel 116	DETECTOR FUNCTION	Peak (PK)
FREQUENCY RANGE	1GHz ~ 40GHz		Average (AV)

ANTENNA POLARITY & TEST DISTANCE: HORIZONTAL AT 3 M

NO.	FREQ. (MHz)	EMISSION LEVEL (dBuV/m)	LIMIT (dBuV/m)	MARGIN (dB)	ANTENNA HEIGHT (m)	TABLE ANGLE (Degree)	RAW VALUE (dBuV)	CORRECTION FACTOR (dB/m)
1	5419.00	56.5 PK	74.0	-17.5	1.43 H	360	50.95	5.55
2	5419.00	47.6 AV	54.0	-6.4	1.43 H	360	42.05	5.55
3	*5580.00	111.3 PK			1.43 H	360	105.53	5.77
4	*5580.00	102.1 AV			1.43 H	360	96.33	5.77
5	#5738.80	66.4 PK	68.2	-1.8	1.43 H	360	60.22	6.18
6	11160.00	46.4 PK	74.0	-27.6	1.54 H	358	29.23	17.17
7	11160.00	33.2 AV	54.0	-20.8	1.54 H	358	16.03	17.17
8	#16740.00	48.4 PK	74.0	-25.6	1.43 H	330	28.72	19.68
9	#16740.00	35.2 AV	54.0	-18.8	1.43 H	330	15.52	19.68

ANTENNA POLARITY & TEST DISTANCE: VERTICAL AT 3 M

NO.	FREQ. (MHz)	EMISSION LEVEL (dBuV/m)	LIMIT (dBuV/m)	MARGIN (dB)	ANTENNA HEIGHT (m)	TABLE ANGLE (Degree)	RAW VALUE (dBuV)	CORRECTION FACTOR (dB/m)
1	5419.00	61.6 PK	74.0	-12.4	1.68 V	360	56.05	5.55
2	5419.00	51.4 AV	54.0	-2.6	1.68 V	360	45.85	5.55
3	*5580.00	113.6 PK			1.68 V	360	107.83	5.77
4	*5580.00	103.4 AV			1.68 V	360	97.63	5.77
5	#5738.80	65.4 PK	68.2	-2.8	1.68 V	5	59.22	6.18
6	11160.00	47.8 PK	74.0	-26.2	2.07 V	324	30.63	17.17
7	11160.00	34.4 AV	54.0	-19.6	2.07 V	324	17.23	17.17
8	#16740.00	49.6 PK	74.0	-24.4	1.75 V	350	29.92	19.68
9	#16740.00	36.5 AV	54.0	-17.5	1.75 V	350	16.82	19.68

REMARKS:

1. Emission Level(dBuV/m) = Raw Value(dBuV) + Correction Factor(dB/m)
2. Correction Factor(dB/m) = Antenna Factor(dB/m) + Cable Factor(dB) – Pre-Amplifier Factor(dB)
3. The other emission levels were very low against the limit.
4. Margin value = Emission Level – Limit value
5. " * ": Fundamental frequency.
6. " # ": The radiated frequency is out of the restricted band.



CHANNEL	TX Channel 140	DETECTOR FUNCTION	Peak (PK)
FREQUENCY RANGE	1GHz ~ 40GHz		Average (AV)

ANTENNA POLARITY & TEST DISTANCE: HORIZONTAL AT 3 M

NO.	FREQ. (MHz)	EMISSION LEVEL (dBuV/m)	LIMIT (dBuV/m)	MARGIN (dB)	ANTENNA HEIGHT (m)	TABLE ANGLE (Degree)	RAW VALUE (dBuV)	CORRECTION FACTOR (dB/m)
1	*5700.00	113.3 PK			1.78 H	302	107.23	6.07
2	*5700.00	102.7 AV			1.78 H	302	96.63	6.07
3	#5725.00	72.2 PK	74.0	-1.8	1.78 H	302	66.06	6.14
4	#5725.00	52.6 AV	54.0	-1.4	1.78 H	302	46.46	6.14
5	#5858.60	65.0 PK	68.2	-3.2	1.91 H	303	58.59	6.41
6	11400.00	50.2 PK	74.0	-23.8	1.52 H	360	33.03	17.17
7	11400.00	36.6 AV	54.0	-17.4	1.52 H	360	19.43	17.17
8	#17100.00	51.4 PK	74.0	-22.6	1.42 H	331	29.59	21.81
9	#17100.00	37.7 AV	54.0	-16.3	1.42 H	331	15.89	21.81

ANTENNA POLARITY & TEST DISTANCE: VERTICAL AT 3 M

NO.	FREQ. (MHz)	EMISSION LEVEL (dBuV/m)	LIMIT (dBuV/m)	MARGIN (dB)	ANTENNA HEIGHT (m)	TABLE ANGLE (Degree)	RAW VALUE (dBuV)	CORRECTION FACTOR (dB/m)
1	*5700.00	115.4 PK			1.59 V	355	109.33	6.07
2	*5700.00	104.8 AV			1.59 V	355	98.73	6.07
3	#5725.00	73.3 PK	74.0	-0.7	1.59 V	355	67.16	6.14
4	#5725.00	53.8 AV	54.0	-0.2	1.59 V	355	47.66	6.14
5	#5858.60	66.8 PK	68.2	-1.4	1.59 V	0	60.39	6.41
6	11400.00	51.2 PK	74.0	-22.8	2.06 V	309	34.03	17.17
7	11400.00	37.2 AV	54.0	-16.8	2.06 V	309	20.03	17.17
8	#17100.00	50.8 PK	74.0	-23.2	1.82 V	345	28.99	21.81
9	#17100.00	38.1 AV	54.0	-15.9	1.82 V	345	16.29	21.81

REMARKS:

1. Emission Level(dBuV/m) = Raw Value(dBuV) + Correction Factor(dB/m)
2. Correction Factor(dB/m) = Antenna Factor(dB/m) + Cable Factor(dB) – Pre-Amplifier Factor(dB)
3. The other emission levels were very low against the limit.
4. Margin value = Emission Level – Limit value
5. " * ": Fundamental frequency.
6. " # ": The radiated frequency is out of the restricted band.

802.11ac (VHT20)

CHANNEL	TX Channel 52	DETECTOR FUNCTION	Peak (PK)
FREQUENCY RANGE	1GHz ~ 40GHz		Average (AV)

ANTENNA POLARITY & TEST DISTANCE: HORIZONTAL AT 3 M

NO.	FREQ. (MHz)	EMISSION LEVEL (dBuV/m)	LIMIT (dBuV/m)	MARGIN (dB)	ANTENNA HEIGHT (m)	TABLE ANGLE (Degree)	RAW VALUE (dBuV)	CORRECTION FACTOR (dB/m)
1	5099.40	58.4 PK	74.0	-15.6	1.56 H	355	53.48	4.92
2	5099.40	46.3 AV	54.0	-7.7	1.56 H	355	41.38	4.92
3	*5260.00	111.2 PK			1.60 H	360	106.05	5.15
4	*5260.00	101.8 AV			1.60 H	360	96.65	5.15
5	5422.00	60.1 PK	74.0	-13.9	1.91 H	360	54.55	5.55
6	5422.00	50.0 AV	54.0	-4.0	1.91 H	360	44.45	5.55
7	#10520.00	49.6 PK	74.0	-24.4	1.61 H	360	33.28	16.32
8	#10520.00	36.0 AV	54.0	-18.0	1.61 H	360	19.68	16.32
9	15780.00	50.2 PK	74.0	-23.8	1.49 H	331	33.10	17.10
10	15780.00	36.4 AV	54.0	-17.6	1.49 H	331	19.30	17.10

ANTENNA POLARITY & TEST DISTANCE: VERTICAL AT 3 M

NO.	FREQ. (MHz)	EMISSION LEVEL (dBuV/m)	LIMIT (dBuV/m)	MARGIN (dB)	ANTENNA HEIGHT (m)	TABLE ANGLE (Degree)	RAW VALUE (dBuV)	CORRECTION FACTOR (dB/m)
1	5099.40	58.2 PK	74.0	-15.8	1.50 V	3	53.28	4.92
2	5099.40	46.6 AV	54.0	-7.4	1.50 V	3	41.68	4.92
3	*5260.00	112.1 PK			1.51 V	360	106.95	5.15
4	*5260.00	101.7 AV			1.51 V	360	96.55	5.15
5	5422.00	62.7 PK	74.0	-11.3	1.75 V	360	57.15	5.55
6	5422.00	52.2 AV	54.0	-1.8	1.75 V	360	46.65	5.55
7	#10520.00	50.0 PK	74.0	-24.0	2.04 V	321	33.68	16.32
8	#10520.00	35.2 AV	54.0	-18.8	2.04 V	321	18.88	16.32
9	15780.00	49.3 PK	74.0	-24.7	1.79 V	331	32.20	17.10
10	15780.00	36.5 AV	54.0	-17.5	1.79 V	331	19.40	17.10

REMARKS:

- Emission Level(dBuV/m) = Raw Value(dBuV) + Correction Factor(dB/m)
- Correction Factor(dB/m) = Antenna Factor(dB/m) + Cable Factor(dB) – Pre-Amplifier Factor(dB)
- The other emission levels were very low against the limit.
- Margin value = Emission Level – Limit value
- " * ": Fundamental frequency.
- " # ": The radiated frequency is out of the restricted band.

CHANNEL	TX Channel 60	DETECTOR FUNCTION	Peak (PK)
FREQUENCY RANGE	1GHz ~ 40GHz		Average (AV)

ANTENNA POLARITY & TEST DISTANCE: HORIZONTAL AT 3 M

NO.	FREQ. (MHz)	EMISSION LEVEL (dBuV/m)	LIMIT (dBuV/m)	MARGIN (dB)	ANTENNA HEIGHT (m)	TABLE ANGLE (Degree)	RAW VALUE (dBuV)	CORRECTION FACTOR (dB/m)
1	5139.30	55.8 PK	74.0	-18.2	1.45 H	360	50.83	4.97
2	5139.30	45.5 AV	54.0	-8.5	1.45 H	360	40.53	4.97
3	*5300.00	110.1 PK			1.45 H	360	104.88	5.22
4	*5300.00	100.0 AV			1.45 H	360	94.78	5.22
5	5381.00	62.0 PK	74.0	-12.0	1.45 H	360	56.55	5.45
6	5381.00	51.1 AV	54.0	-2.9	1.45 H	360	45.65	5.45
7	10600.00	49.7 PK	74.0	-24.3	1.58 H	355	33.25	16.45
8	10600.00	36.0 AV	54.0	-18.0	1.58 H	355	19.55	16.45
9	15900.00	51.2 PK	74.0	-22.8	1.47 H	342	34.64	16.56
10	15900.00	37.2 AV	54.0	-16.8	1.47 H	342	20.64	16.56

ANTENNA POLARITY & TEST DISTANCE: VERTICAL AT 3 M

NO.	FREQ. (MHz)	EMISSION LEVEL (dBuV/m)	LIMIT (dBuV/m)	MARGIN (dB)	ANTENNA HEIGHT (m)	TABLE ANGLE (Degree)	RAW VALUE (dBuV)	CORRECTION FACTOR (dB/m)
1	5139.30	57.4 PK	74.0	-16.6	1.57 V	360	52.43	4.97
2	5139.30	47.1 AV	54.0	-6.9	1.57 V	360	42.13	4.97
3	*5300.00	111.9 PK			1.64 V	6	106.68	5.22
4	*5300.00	101.6 AV			1.64 V	6	96.38	5.22
5	5381.00	64.0 PK	74.0	-10.0	1.64 V	360	58.55	5.45
6	5381.00	52.9 AV	54.0	-1.1	1.64 V	360	47.45	5.45
7	10600.00	49.7 PK	74.0	-24.3	2.10 V	298	33.25	16.45
8	10600.00	35.5 AV	54.0	-18.5	2.10 V	298	19.05	16.45
9	15900.00	49.3 PK	74.0	-24.7	1.80 V	347	32.74	16.56
10	15900.00	36.8 AV	54.0	-17.2	1.80 V	347	20.24	16.56

REMARKS:

1. Emission Level(dBuV/m) = Raw Value(dBuV) + Correction Factor(dB/m)
2. Correction Factor(dB/m) = Antenna Factor(dB/m) + Cable Factor(dB) – Pre-Amplifier Factor(dB)
3. The other emission levels were very low against the limit.
4. Margin value = Emission Level – Limit value
5. " * ": Fundamental frequency.

CHANNEL	TX Channel 64	DETECTOR FUNCTION	Peak (PK)
FREQUENCY RANGE	1GHz ~ 40GHz		Average (AV)

ANTENNA POLARITY & TEST DISTANCE: HORIZONTAL AT 3 M

NO.	FREQ. (MHz)	EMISSION LEVEL (dBuV/m)	LIMIT (dBuV/m)	MARGIN (dB)	ANTENNA HEIGHT (m)	TABLE ANGLE (Degree)	RAW VALUE (dBuV)	CORRECTION FACTOR (dB/m)
1	*5320.00	110.4 PK			1.42 H	360	105.12	5.28
2	*5320.00	99.7 AV			1.42 H	360	94.42	5.28
3	5350.00	69.7 PK	74.0	-4.3	1.42 H	360	64.34	5.36
4	5350.00	49.8 AV	54.0	-4.2	1.42 H	360	44.44	5.36
5	5399.40	60.8 PK	74.0	-13.2	1.42 H	360	55.30	5.50
6	5399.40	50.0 AV	54.0	-4.0	1.42 H	360	44.50	5.50
7	10640.00	49.1 PK	74.0	-24.9	1.60 H	360	32.77	16.33
8	10640.00	35.3 AV	54.0	-18.7	1.60 H	360	18.97	16.33
9	15960.00	48.8 PK	74.0	-25.2	1.49 H	328	32.10	16.70
10	15960.00	36.2 AV	54.0	-17.8	1.49 H	328	19.50	16.70

ANTENNA POLARITY & TEST DISTANCE: VERTICAL AT 3 M

NO.	FREQ. (MHz)	EMISSION LEVEL (dBuV/m)	LIMIT (dBuV/m)	MARGIN (dB)	ANTENNA HEIGHT (m)	TABLE ANGLE (Degree)	RAW VALUE (dBuV)	CORRECTION FACTOR (dB/m)
1	*5320.00	112.1 PK			1.52 V	360	106.82	5.28
2	*5320.00	101.4 AV			1.52 V	360	96.12	5.28
3	5350.00	68.7 PK	74.0	-5.3	1.52 V	360	63.34	5.36
4	5350.00	51.6 AV	54.0	-2.4	1.52 V	360	46.24	5.36
5	5399.40	62.2 PK	74.0	-11.8	1.84 V	360	56.70	5.50
6	5399.40	51.7 AV	54.0	-2.3	1.84 V	360	46.20	5.50
7	10640.00	48.9 PK	74.0	-25.1	2.02 V	315	32.57	16.33
8	10640.00	35.5 AV	54.0	-18.5	2.02 V	315	19.17	16.33
9	15960.00	48.6 PK	74.0	-25.4	1.80 V	329	31.90	16.70
10	15960.00	35.8 AV	54.0	-18.2	1.80 V	329	19.10	16.70

REMARKS:

1. Emission Level(dBuV/m) = Raw Value(dBuV) + Correction Factor(dB/m)
2. Correction Factor(dB/m) = Antenna Factor(dB/m) + Cable Factor(dB) – Pre-Amplifier Factor(dB)
3. The other emission levels were very low against the limit.
4. Margin value = Emission Level – Limit value
5. " * ": Fundamental frequency.

CHANNEL	TX Channel 100	DETECTOR FUNCTION	Peak (PK)
FREQUENCY RANGE	1GHz ~ 40GHz		Average (AV)

ANTENNA POLARITY & TEST DISTANCE: HORIZONTAL AT 3 M

NO.	FREQ. (MHz)	EMISSION LEVEL (dBuV/m)	LIMIT (dBuV/m)	MARGIN (dB)	ANTENNA HEIGHT (m)	TABLE ANGLE (Degree)	RAW VALUE (dBuV)	CORRECTION FACTOR (dB/m)
1	5421.00	59.5 PK	74.0	-14.5	1.71 H	360	53.95	5.55
2	5421.00	49.1 AV	54.0	-4.9	1.71 H	360	43.55	5.55
3	#5470.00	66.4 PK	74.0	-7.6	1.57 H	318	60.76	5.64
4	#5470.00	49.6 AV	54.0	-4.4	1.57 H	318	43.96	5.64
5	*5500.00	111.7 PK			1.57 H	318	106.00	5.70
6	*5500.00	100.2 AV			1.57 H	318	94.50	5.70
7	#5742.00	57.0 PK	74.0	-17.0	1.68 H	360	50.81	6.19
8	#5742.00	46.2 AV	54.0	-7.8	1.68 H	360	40.01	6.19
9	11000.00	51.1 PK	74.0	-22.9	1.62 H	358	33.92	17.18
10	11000.00	37.2 AV	54.0	-16.8	1.62 H	358	20.02	17.18
11	#16500.00	51.9 PK	74.0	-22.1	1.45 H	329	32.36	19.54
12	#16500.00	38.1 AV	54.0	-15.9	1.45 H	329	18.56	19.54

ANTENNA POLARITY & TEST DISTANCE: VERTICAL AT 3 M

NO.	FREQ. (MHz)	EMISSION LEVEL (dBuV/m)	LIMIT (dBuV/m)	MARGIN (dB)	ANTENNA HEIGHT (m)	TABLE ANGLE (Degree)	RAW VALUE (dBuV)	CORRECTION FACTOR (dB/m)
1	5421.00	63.0 PK	74.0	-11.0	1.57 V	6	57.45	5.55
2	5421.00	52.0 AV	54.0	-2.0	1.57 V	6	46.45	5.55
3	#5470.00	71.3 PK	74.0	-2.7	1.57 V	6	65.66	5.64
4	#5470.00	53.6 AV	54.0	-0.4	1.57 V	6	47.96	5.64
5	*5500.00	113.5 PK			1.57 V	6	107.80	5.70
6	*5500.00	103.0 AV			1.57 V	6	97.30	5.70
7	#5742.00	61.4 PK	74.0	-12.6	1.54 V	0	55.21	6.19
8	#5742.00	50.4 AV	54.0	-3.6	1.54 V	0	44.21	6.19
9	11000.00	51.5 PK	74.0	-22.5	2.07 V	310	34.32	17.18
10	11000.00	37.2 AV	54.0	-16.8	2.07 V	310	20.02	17.18
11	#16500.00	50.8 PK	74.0	-23.2	1.82 V	336	31.26	19.54
12	#16500.00	38.1 AV	54.0	-15.9	1.82 V	336	18.56	19.54

REMARKS:

1. Emission Level(dBuV/m) = Raw Value(dBuV) + Correction Factor(dB/m)
2. Correction Factor(dB/m) = Antenna Factor(dB/m) + Cable Factor(dB) – Pre-Amplifier Factor(dB)
3. The other emission levels were very low against the limit.
4. Margin value = Emission Level – Limit value
5. " * ": Fundamental frequency.
6. " # ": The radiated frequency is out of the restricted band.

CHANNEL	TX Channel 116	DETECTOR FUNCTION	Peak (PK)
FREQUENCY RANGE	1GHz ~ 40GHz		Average (AV)

ANTENNA POLARITY & TEST DISTANCE: HORIZONTAL AT 3 M

NO.	FREQ. (MHz)	EMISSION LEVEL (dBuV/m)	LIMIT (dBuV/m)	MARGIN (dB)	ANTENNA HEIGHT (m)	TABLE ANGLE (Degree)	RAW VALUE (dBuV)	CORRECTION FACTOR (dB/m)
1	5421.00	55.9 PK	74.0	-18.1	1.42 H	360	50.35	5.55
2	5421.00	45.9 AV	54.0	-8.1	1.42 H	360	40.35	5.55
3	*5580.00	110.6 PK			1.42 H	360	104.83	5.77
4	*5580.00	99.3 AV			1.42 H	360	93.53	5.77
5	#5739.00	62.0 PK	74.0	-12.0	1.42 H	360	55.82	6.18
6	#5739.00	51.5 AV	54.0	-2.5	1.42 H	360	45.32	6.18
7	11160.00	51.0 PK	74.0	-23.0	1.61 H	344	33.83	17.17
8	11160.00	37.0 AV	54.0	-17.0	1.61 H	344	19.83	17.17
9	#16740.00	51.6 PK	74.0	-22.4	1.49 H	334	31.92	19.68
10	#16740.00	37.8 AV	54.0	-16.2	1.49 H	334	18.12	19.68

ANTENNA POLARITY & TEST DISTANCE: VERTICAL AT 3 M

NO.	FREQ. (MHz)	EMISSION LEVEL (dBuV/m)	LIMIT (dBuV/m)	MARGIN (dB)	ANTENNA HEIGHT (m)	TABLE ANGLE (Degree)	RAW VALUE (dBuV)	CORRECTION FACTOR (dB/m)
1	5421.00	58.1 PK	74.0	-15.9	1.48 V	360	52.55	5.55
2	5421.00	48.0 AV	54.0	-6.0	1.48 V	360	42.45	5.55
3	*5580.00	111.8 PK			1.40 V	360	106.03	5.77
4	*5580.00	100.7 AV			1.40 V	360	94.93	5.77
5	#5739.00	63.9 PK	74.0	-10.1	1.52 V	358	57.72	6.18
6	#5739.00	52.9 AV	54.0	-1.1	1.52 V	358	46.72	6.18
7	11160.00	51.3 PK	74.0	-22.7	2.12 V	307	34.13	17.17
8	11160.00	37.2 AV	54.0	-16.8	2.12 V	307	20.03	17.17
9	#16740.00	50.6 PK	74.0	-23.4	1.80 V	359	30.92	19.68
10	#16740.00	37.9 AV	54.0	-16.1	1.80 V	359	18.22	19.68

REMARKS:

- Emission Level(dBuV/m) = Raw Value(dBuV) + Correction Factor(dB/m)
- Correction Factor(dB/m) = Antenna Factor(dB/m) + Cable Factor(dB) – Pre-Amplifier Factor(dB)
- The other emission levels were very low against the limit.
- Margin value = Emission Level – Limit value
- " * ": Fundamental frequency.
- " # ": The radiated frequency is out of the restricted band.

CHANNEL	TX Channel 140	DETECTOR FUNCTION	Peak (PK)
FREQUENCY RANGE	1GHz ~ 40GHz		Average (AV)

ANTENNA POLARITY & TEST DISTANCE: HORIZONTAL AT 3 M

NO.	FREQ. (MHz)	EMISSION LEVEL (dBuV/m)	LIMIT (dBuV/m)	MARGIN (dB)	ANTENNA HEIGHT (m)	TABLE ANGLE (Degree)	RAW VALUE (dBuV)	CORRECTION FACTOR (dB/m)
1	*5700.00	111.8 PK			1.43 H	360	105.73	6.07
2	*5700.00	101.1 AV			1.43 H	360	95.03	6.07
3	#5725.00	70.2 PK	74.0	-3.8	1.43 H	360	64.06	6.14
4	#5725.00	52.2 AV	54.0	-1.8	1.43 H	360	46.06	6.14
5	#5862.20	63.3 PK	68.2	-4.9	1.43 H	360	56.89	6.41
6	11400.00	51.8 PK	74.0	-22.2	1.57 H	347	34.63	17.17
7	11400.00	37.6 AV	54.0	-16.4	1.57 H	347	20.43	17.17
8	#17100.00	52.3 PK	74.0	-21.7	1.42 H	331	30.49	21.81
9	#17100.00	38.5 AV	54.0	-15.5	1.42 H	331	16.69	21.81

ANTENNA POLARITY & TEST DISTANCE: VERTICAL AT 3 M

NO.	FREQ. (MHz)	EMISSION LEVEL (dBuV/m)	LIMIT (dBuV/m)	MARGIN (dB)	ANTENNA HEIGHT (m)	TABLE ANGLE (Degree)	RAW VALUE (dBuV)	CORRECTION FACTOR (dB/m)
1	*5700.00	113.6 PK			1.49 V	2	107.53	6.07
2	*5700.00	102.9 AV			1.49 V	2	96.83	6.07
3	#5725.00	72.1 PK	74.0	-1.9	1.49 V	2	65.96	6.14
4	#5725.00	53.9 AV	54.0	-0.1	1.49 V	2	47.76	6.14
5	#5862.20	65.3 PK	68.2	-2.9	1.73 V	356	58.89	6.41
6	11400.00	51.5 PK	74.0	-22.5	2.01 V	305	34.33	17.17
7	11400.00	37.3 AV	54.0	-16.7	2.01 V	305	20.13	17.17
8	#17100.00	51.1 PK	74.0	-22.9	1.77 V	357	29.29	21.81
9	#17100.00	38.2 AV	54.0	-15.8	1.77 V	357	16.39	21.81

REMARKS:

1. Emission Level(dBuV/m) = Raw Value(dBuV) + Correction Factor(dB/m)
2. Correction Factor(dB/m) = Antenna Factor(dB/m) + Cable Factor(dB) – Pre-Amplifier Factor(dB)
3. The other emission levels were very low against the limit.
4. Margin value = Emission Level – Limit value
5. " * ": Fundamental frequency.
6. " # ": The radiated frequency is out of the restricted band.

802.11ac (VHT40)

CHANNEL	TX Channel 54	DETECTOR FUNCTION	Peak (PK)
FREQUENCY RANGE	1GHz ~ 40GHz		Average (AV)

ANTENNA POLARITY & TEST DISTANCE: HORIZONTAL AT 3 M								
NO.	FREQ. (MHz)	EMISSION LEVEL (dBuV/m)	LIMIT (dBuV/m)	MARGIN (dB)	ANTENNA HEIGHT (m)	TABLE ANGLE (Degree)	RAW VALUE (dBuV)	CORRECTION FACTOR (dB/m)
1	*5270.00	108.4 PK			1.43 H	360	103.24	5.16
2	*5270.00	97.5 AV			1.43 H	360	92.34	5.16
3	5354.00	58.2 PK	74.0	-15.8	1.43 H	360	52.82	5.38
4	5354.00	48.2 AV	54.0	-5.8	1.43 H	360	42.82	5.38
5	#10540.00	51.5 PK	74.0	-22.5	1.63 H	360	35.15	16.35
6	#10540.00	37.6 AV	54.0	-16.4	1.63 H	360	21.25	16.35
7	15810.00	51.5 PK	74.0	-22.5	1.48 H	341	34.59	16.91
8	15810.00	37.7 AV	54.0	-16.3	1.48 H	341	20.79	16.91
ANTENNA POLARITY & TEST DISTANCE: VERTICAL AT 3 M								
NO.	FREQ. (MHz)	EMISSION LEVEL (dBuV/m)	LIMIT (dBuV/m)	MARGIN (dB)	ANTENNA HEIGHT (m)	TABLE ANGLE (Degree)	RAW VALUE (dBuV)	CORRECTION FACTOR (dB/m)
1	*5270.00	110.5 PK			1.57 V	2	105.34	5.16
2	*5270.00	99.2 AV			1.57 V	2	94.04	5.16
3	5354.00	60.4 PK	74.0	-13.6	1.71 V	360	55.02	5.38
4	5354.00	50.2 AV	54.0	-3.8	1.71 V	360	44.82	5.38
5	#10540.00	50.6 PK	74.0	-23.4	2.07 V	304	34.25	16.35
6	#10540.00	36.7 AV	54.0	-17.3	2.07 V	304	20.35	16.35
7	15810.00	50.7 PK	74.0	-23.3	1.82 V	331	33.79	16.91
8	15810.00	38.1 AV	54.0	-15.9	1.82 V	331	21.19	16.91

REMARKS:

1. Emission Level(dBuV/m) = Raw Value(dBuV) + Correction Factor(dB/m)
2. Correction Factor(dB/m) = Antenna Factor(dB/m) + Cable Factor(dB) – Pre-Amplifier Factor(dB)
3. The other emission levels were very low against the limit.
4. Margin value = Emission Level – Limit value
5. " * ": Fundamental frequency.
6. " # ": The radiated frequency is out of the restricted band.



CHANNEL	TX Channel 62	DETECTOR FUNCTION	Peak (PK)
FREQUENCY RANGE	1GHz ~ 40GHz		Average (AV)

ANTENNA POLARITY & TEST DISTANCE: HORIZONTAL AT 3 M

NO.	FREQ. (MHz)	EMISSION LEVEL (dBuV/m)	LIMIT (dBuV/m)	MARGIN (dB)	ANTENNA HEIGHT (m)	TABLE ANGLE (Degree)	RAW VALUE (dBuV)	CORRECTION FACTOR (dB/m)
1	*5310.00	105.5 PK			1.42 H	360	100.25	5.25
2	*5310.00	93.8 AV			1.42 H	360	88.55	5.25
3	5350.00	68.6 PK	74.0	-5.4	1.42 H	360	63.24	5.36
4	5350.00	51.4 AV	54.0	-2.6	1.42 H	360	46.04	5.36
5	10620.00	50.7 PK	74.0	-23.3	1.58 H	356	34.31	16.39
6	10620.00	37.0 AV	54.0	-17.0	1.58 H	356	20.61	16.39
7	15930.00	52.0 PK	74.0	-22.0	1.49 H	326	35.36	16.64
8	15930.00	38.2 AV	54.0	-15.8	1.49 H	326	21.56	16.64

ANTENNA POLARITY & TEST DISTANCE: VERTICAL AT 3 M

NO.	FREQ. (MHz)	EMISSION LEVEL (dBuV/m)	LIMIT (dBuV/m)	MARGIN (dB)	ANTENNA HEIGHT (m)	TABLE ANGLE (Degree)	RAW VALUE (dBuV)	CORRECTION FACTOR (dB/m)
1	*5310.00	107.7 PK			1.54 V	360	102.45	5.25
2	*5310.00	96.0 AV			1.54 V	360	90.75	5.25
3	5350.00	70.9 PK	74.0	-3.1	1.54 V	360	65.54	5.36
4	5350.00	53.8 AV	54.0	-0.2	1.54 V	360	48.44	5.36
5	10620.00	50.4 PK	74.0	-23.6	2.02 V	316	34.01	16.39
6	10620.00	36.7 AV	54.0	-17.3	2.02 V	316	20.31	16.39
7	15930.00	50.2 PK	74.0	-23.8	1.78 V	345	33.56	16.64
8	15930.00	37.6 AV	54.0	-16.4	1.78 V	345	20.96	16.64

REMARKS:

1. Emission Level(dBuV/m) = Raw Value(dBuV) + Correction Factor(dB/m)
2. Correction Factor(dB/m) = Antenna Factor(dB/m) + Cable Factor(dB) – Pre-Amplifier Factor(dB)
3. The other emission levels were very low against the limit.
4. Margin value = Emission Level – Limit value
5. " * ": Fundamental frequency.



CHANNEL	TX Channel 102	DETECTOR FUNCTION	Peak (PK)
FREQUENCY RANGE	1GHz ~ 40GHz		Average (AV)

ANTENNA POLARITY & TEST DISTANCE: HORIZONTAL AT 3 M

NO.	FREQ. (MHz)	EMISSION LEVEL (dBuV/m)	LIMIT (dBuV/m)	MARGIN (dB)	ANTENNA HEIGHT (m)	TABLE ANGLE (Degree)	RAW VALUE (dBuV)	CORRECTION FACTOR (dB/m)
1	#5470.00	66.7 PK	74.0	-7.3	1.44 H	360	61.06	5.64
2	#5470.00	51.4 AV	54.0	-2.6	1.44 H	360	45.76	5.64
3	*5510.00	106.0 PK			1.44 H	360	100.29	5.71
4	*5510.00	94.1 AV			1.44 H	360	88.39	5.71
5	11020.00	51.0 PK	74.0	-23.0	1.64 H	360	33.73	17.27
6	11020.00	37.3 AV	54.0	-16.7	1.64 H	360	20.03	17.27
7	#16530.00	52.2 PK	74.0	-21.8	1.40 H	327	32.65	19.55
8	#16530.00	38.6 AV	54.0	-15.4	1.40 H	327	19.05	19.55

ANTENNA POLARITY & TEST DISTANCE: VERTICAL AT 3 M

NO.	FREQ. (MHz)	EMISSION LEVEL (dBuV/m)	LIMIT (dBuV/m)	MARGIN (dB)	ANTENNA HEIGHT (m)	TABLE ANGLE (Degree)	RAW VALUE (dBuV)	CORRECTION FACTOR (dB/m)
1	#5470.00	69.2 PK	74.0	-4.8	1.54 V	360	63.56	5.64
2	#5470.00	53.7 AV	54.0	-0.3	1.54 V	360	48.06	5.64
3	*5510.00	107.6 PK			1.54 V	360	101.89	5.71
4	*5510.00	95.9 AV			1.54 V	360	90.19	5.71
5	11020.00	51.7 PK	74.0	-22.3	2.08 V	316	34.43	17.27
6	11020.00	37.5 AV	54.0	-16.5	2.08 V	316	20.23	17.27
7	#16530.00	50.8 PK	74.0	-23.2	1.85 V	358	31.25	19.55
8	#16530.00	38.3 AV	54.0	-15.7	1.85 V	358	18.75	19.55

REMARKS:

1. Emission Level(dBuV/m) = Raw Value(dBuV) + Correction Factor(dB/m)
2. Correction Factor(dB/m) = Antenna Factor(dB/m) + Cable Factor(dB) – Pre-Amplifier Factor(dB)
3. The other emission levels were very low against the limit.
4. Margin value = Emission Level – Limit value
5. " * ": Fundamental frequency.
6. " # ": The radiated frequency is out of the restricted band.



CHANNEL	TX Channel 110	DETECTOR FUNCTION	Peak (PK)
FREQUENCY RANGE	1GHz ~ 40GHz		Average (AV)

ANTENNA POLARITY & TEST DISTANCE: HORIZONTAL AT 3 M

NO.	FREQ. (MHz)	EMISSION LEVEL (dBuV/m)	LIMIT (dBuV/m)	MARGIN (dB)	ANTENNA HEIGHT (m)	TABLE ANGLE (Degree)	RAW VALUE (dBuV)	CORRECTION FACTOR (dB/m)
1	#5470.00	66.2 PK	74.0	-7.8	1.43 H	360	60.56	5.64
2	#5470.00	51.7 AV	54.0	-2.3	1.43 H	360	46.06	5.64
3	*5550.00	111.1 PK			1.43 H	360	105.36	5.74
4	*5550.00	99.8 AV			1.43 H	360	94.06	5.74
5	#5727.00	59.0 PK	74.0	-15.0	1.43 H	360	52.85	6.15
6	#5727.00	48.7 AV	54.0	-5.3	1.43 H	360	42.55	6.15
7	11100.00	51.3 PK	74.0	-22.7	1.64 H	360	33.65	17.65
8	11100.00	37.5 AV	54.0	-16.5	1.64 H	360	19.85	17.65
9	#16650.00	51.7 PK	74.0	-22.3	1.43 H	324	32.13	19.57
10	#16650.00	38.1 AV	54.0	-15.9	1.43 H	324	18.53	19.57

ANTENNA POLARITY & TEST DISTANCE: VERTICAL AT 3 M

NO.	FREQ. (MHz)	EMISSION LEVEL (dBuV/m)	LIMIT (dBuV/m)	MARGIN (dB)	ANTENNA HEIGHT (m)	TABLE ANGLE (Degree)	RAW VALUE (dBuV)	CORRECTION FACTOR (dB/m)
1	#5470.00	68.3 PK	74.0	-5.7	1.64 V	360	62.66	5.64
2	#5470.00	53.9 AV	54.0	-0.1	1.64 V	360	48.26	5.64
3	*5550.00	113.2 PK			1.64 V	360	107.46	5.74
4	*5550.00	101.9 AV			1.64 V	360	96.16	5.74
5	#5727.00	61.5 PK	74.0	-12.5	1.65 V	356	55.35	6.15
6	#5727.00	50.9 AV	54.0	-3.1	1.65 V	356	44.75	6.15
7	11100.00	51.7 PK	74.0	-22.3	2.04 V	313	34.05	17.65
8	11100.00	37.4 AV	54.0	-16.6	2.04 V	313	19.75	17.65
9	#16650.00	50.5 PK	74.0	-23.5	1.85 V	333	30.93	19.57
10	#16650.00	37.9 AV	54.0	-16.1	1.85 V	333	18.33	19.57

REMARKS:

- Emission Level(dBuV/m) = Raw Value(dBuV) + Correction Factor(dB/m)
- Correction Factor(dB/m) = Antenna Factor(dB/m) + Cable Factor(dB) – Pre-Amplifier Factor(dB)
- The other emission levels were very low against the limit.
- Margin value = Emission Level – Limit value
- " * ": Fundamental frequency.
- " # ": The radiated frequency is out of the restricted band.



CHANNEL	TX Channel 134	DETECTOR FUNCTION	Peak (PK)
FREQUENCY RANGE	1GHz ~ 40GHz		Average (AV)

ANTENNA POLARITY & TEST DISTANCE: HORIZONTAL AT 3 M

NO.	FREQ. (MHz)	EMISSION LEVEL (dBuV/m)	LIMIT (dBuV/m)	MARGIN (dB)	ANTENNA HEIGHT (m)	TABLE ANGLE (Degree)	RAW VALUE (dBuV)	CORRECTION FACTOR (dB/m)
1	*5670.00	110.5 PK			1.41 H	360	104.53	5.97
2	*5670.00	98.2 AV			1.41 H	360	92.23	5.97
3	#5744.50	67.7 PK	74.0	-6.3	1.41 H	360	61.51	6.19
4	#5744.50	52.1 AV	54.0	-1.9	1.41 H	360	45.91	6.19
5	11340.00	51.5 PK	74.0	-22.5	1.68 H	358	34.27	17.23
6	11340.00	37.3 AV	54.0	-16.7	1.68 H	358	20.07	17.23
7	#17010.00	52.2 PK	74.0	-21.8	1.41 H	339	30.56	21.64
8	#17010.00	38.2 AV	54.0	-15.8	1.41 H	339	16.56	21.64

ANTENNA POLARITY & TEST DISTANCE: VERTICAL AT 3 M

NO.	FREQ. (MHz)	EMISSION LEVEL (dBuV/m)	LIMIT (dBuV/m)	MARGIN (dB)	ANTENNA HEIGHT (m)	TABLE ANGLE (Degree)	RAW VALUE (dBuV)	CORRECTION FACTOR (dB/m)
1	*5670.00	112.4 PK			1.72 V	360	106.43	5.97
2	*5670.00	100.1 AV			1.72 V	360	94.13	5.97
3	#5744.50	69.4 PK	74.0	-4.6	1.72 V	360	63.21	6.19
4	#5744.50	53.7 AV	54.0	-0.3	1.72 V	360	47.51	6.19
5	11340.00	51.2 PK	74.0	-22.8	2.04 V	315	33.97	17.23
6	11340.00	37.3 AV	54.0	-16.7	2.04 V	315	20.07	17.23
7	#17010.00	51.3 PK	74.0	-22.7	1.80 V	334	29.66	21.64
8	#17010.00	38.5 AV	54.0	-15.5	1.80 V	334	16.86	21.64

REMARKS:

1. Emission Level(dBuV/m) = Raw Value(dBuV) + Correction Factor(dB/m)
2. Correction Factor(dB/m) = Antenna Factor(dB/m) + Cable Factor(dB) – Pre-Amplifier Factor(dB)
3. The other emission levels were very low against the limit.
4. Margin value = Emission Level – Limit value
5. " * ": Fundamental frequency.
6. " # ": The radiated frequency is out of the restricted band.



802.11ac (VHT80)

CHANNEL	TX Channel 58	DETECTOR FUNCTION	Peak (PK)
FREQUENCY RANGE	1GHz ~ 40GHz		Average (AV)

ANTENNA POLARITY & TEST DISTANCE: HORIZONTAL AT 3 M

NO.	FREQ. (MHz)	EMISSION LEVEL (dBuV/m)	LIMIT (dBuV/m)	MARGIN (dB)	ANTENNA HEIGHT (m)	TABLE ANGLE (Degree)	RAW VALUE (dBuV)	CORRECTION FACTOR (dB/m)
1	5150.00	66.5 PK	74.0	-7.5	1.37 H	360	61.53	4.97
2	5150.00	49.6 AV	54.0	-4.4	1.37 H	360	44.63	4.97
3	*5290.00	101.9 PK			1.37 H	360	96.70	5.20
4	*5290.00	89.6 AV			1.37 H	360	84.40	5.20
5	5358.00	68.5 PK	74.0	-5.5	1.37 H	360	63.11	5.39
6	5358.00	51.9 AV	54.0	-2.1	1.37 H	360	46.51	5.39
7	#10580.00	51.2 PK	74.0	-22.8	1.59 H	359	34.79	16.41
8	#10580.00	37.6 AV	54.0	-16.4	1.59 H	359	21.19	16.41
9	15870.00	51.5 PK	74.0	-22.5	1.46 H	332	34.82	16.68
10	15870.00	38.0 AV	54.0	-16.0	1.46 H	332	21.32	16.68

ANTENNA POLARITY & TEST DISTANCE: VERTICAL AT 3 M

NO.	FREQ. (MHz)	EMISSION LEVEL (dBuV/m)	LIMIT (dBuV/m)	MARGIN (dB)	ANTENNA HEIGHT (m)	TABLE ANGLE (Degree)	RAW VALUE (dBuV)	CORRECTION FACTOR (dB/m)
1	5150.00	68.4 PK	74.0	-5.6	1.56 V	3	63.43	4.97
2	5150.00	51.4 AV	54.0	-2.6	1.56 V	3	46.43	4.97
3	*5290.00	103.8 PK			1.56 V	3	98.60	5.20
4	*5290.00	91.4 AV			1.56 V	3	86.20	5.20
5	5358.00	70.1 PK	74.0	-3.9	1.56 V	3	64.71	5.39
6	5358.00	53.7 AV	54.0	-0.3	1.56 V	3	48.31	5.39
7	#10580.00	51.3 PK	74.0	-22.7	2.08 V	309	34.89	16.41
8	#10580.00	37.1 AV	54.0	-16.9	2.08 V	309	20.69	16.41
9	15870.00	50.7 PK	74.0	-23.3	1.88 V	334	34.02	16.68
10	15870.00	37.7 AV	54.0	-16.3	1.88 V	334	21.02	16.68

REMARKS:

1. Emission Level(dBuV/m) = Raw Value(dBuV) + Correction Factor(dB/m)
2. Correction Factor(dB/m) = Antenna Factor(dB/m) + Cable Factor(dB) – Pre-Amplifier Factor(dB)
3. The other emission levels were very low against the limit.
4. Margin value = Emission Level – Limit value
5. " * ": Fundamental frequency.
6. " # ": The radiated frequency is out of the restricted band.

CHANNEL	TX Channel 106	DETECTOR FUNCTION	Peak (PK)
FREQUENCY RANGE	1GHz ~ 40GHz		Average (AV)

ANTENNA POLARITY & TEST DISTANCE: HORIZONTAL AT 3 M

NO.	FREQ. (MHz)	EMISSION LEVEL (dBuV/m)	LIMIT (dBuV/m)	MARGIN (dB)	ANTENNA HEIGHT (m)	TABLE ANGLE (Degree)	RAW VALUE (dBuV)	CORRECTION FACTOR (dB/m)
1	5458.00	67.9 PK	74.0	-6.1	1.37 H	360	62.28	5.62
2	5458.00	51.5 AV	54.0	-2.5	1.37 H	360	45.88	5.62
3	*5530.00	102.1 PK			1.37 H	360	96.38	5.72
4	*5530.00	89.6 AV			1.37 H	360	83.88	5.72
5	#5725.00	66.5 PK	74.0	-7.5	1.37 H	360	60.36	6.14
6	#5725.00	48.4 AV	54.0	-5.6	1.37 H	360	42.26	6.14
7	11060.00	51.4 PK	74.0	-22.6	1.57 H	360	33.94	17.46
8	11060.00	37.3 AV	54.0	-16.7	1.57 H	360	19.84	17.46
9	#16590.00	52.2 PK	74.0	-21.8	1.49 H	337	32.64	19.56
10	#16590.00	38.3 AV	54.0	-15.7	1.49 H	337	18.74	19.56

ANTENNA POLARITY & TEST DISTANCE: VERTICAL AT 3 M

NO.	FREQ. (MHz)	EMISSION LEVEL (dBuV/m)	LIMIT (dBuV/m)	MARGIN (dB)	ANTENNA HEIGHT (m)	TABLE ANGLE (Degree)	RAW VALUE (dBuV)	CORRECTION FACTOR (dB/m)
1	5458.00	70.3 PK	74.0	-3.7	1.41 V	360	64.68	5.62
2	5458.00	53.7 AV	54.0	-0.3	1.41 V	360	48.08	5.62
3	*5530.00	103.8 PK			1.41 V	360	98.08	5.72
4	*5530.00	91.1 AV			1.41 V	360	85.38	5.72
5	#5725.00	68.4 PK	74.0	-5.6	1.41 V	360	62.26	6.14
6	#5725.00	50.4 AV	54.0	-3.6	1.41 V	360	44.26	6.14
7	11060.00	51.8 PK	74.0	-22.2	2.04 V	315	34.34	17.46
8	11060.00	37.6 AV	54.0	-16.4	2.04 V	315	20.14	17.46
9	#16590.00	50.5 PK	74.0	-23.5	1.83 V	340	30.94	19.56
10	#16590.00	37.9 AV	54.0	-16.1	1.83 V	340	18.34	19.56

REMARKS:

1. Emission Level(dBuV/m) = Raw Value(dBuV) + Correction Factor(dB/m)
2. Correction Factor(dB/m) = Antenna Factor(dB/m) + Cable Factor(dB) – Pre-Amplifier Factor(dB)
3. The other emission levels were very low against the limit.
4. Margin value = Emission Level – Limit value
5. " * ": Fundamental frequency.
6. " # ": The radiated frequency is out of the restricted band.

CHANNEL	TX Channel 122	DETECTOR FUNCTION	Peak (PK)
FREQUENCY RANGE	1GHz ~ 40GHz		Average (AV)

ANTENNA POLARITY & TEST DISTANCE: HORIZONTAL AT 3 M

NO.	FREQ. (MHz)	EMISSION LEVEL (dBuV/m)	LIMIT (dBuV/m)	MARGIN (dB)	ANTENNA HEIGHT (m)	TABLE ANGLE (Degree)	RAW VALUE (dBuV)	CORRECTION FACTOR (dB/m)
1	#5463.00	65.2 PK	74.0	-8.8	1.42 H	360	59.57	5.63
2	#5463.00	51.1 AV	54.0	-2.9	1.42 H	360	45.47	5.63
3	*5610.00	108.4 PK			1.42 H	360	102.59	5.81
4	*5610.00	95.1 AV			1.42 H	360	89.29	5.81
5	#5744.00	66.6 PK	74.0	-7.4	1.42 H	360	60.41	6.19
6	#5744.00	52.0 AV	54.0	-2.0	1.42 H	360	45.81	6.19
7	11220.00	51.2 PK	74.0	-22.8	1.64 H	342	34.27	16.93
8	11220.00	37.3 AV	54.0	-16.7	1.64 H	342	20.37	16.93
9	#16830.00	52.5 PK	74.0	-21.5	1.48 H	334	32.48	20.02
10	#16830.00	38.5 AV	54.0	-15.5	1.48 H	334	18.48	20.02

ANTENNA POLARITY & TEST DISTANCE: VERTICAL AT 3 M

NO.	FREQ. (MHz)	EMISSION LEVEL (dBuV/m)	LIMIT (dBuV/m)	MARGIN (dB)	ANTENNA HEIGHT (m)	TABLE ANGLE (Degree)	RAW VALUE (dBuV)	CORRECTION FACTOR (dB/m)
1	#5463.00	67.3 PK	74.0	-6.7	1.53 V	360	61.67	5.63
2	#5463.00	53.0 AV	54.0	-1.0	1.53 V	360	47.37	5.63
3	*5610.00	109.8 PK			1.53 V	360	103.99	5.81
4	*5610.00	96.8 AV			1.53 V	360	90.99	5.81
5	#5744.00	68.5 PK	74.0	-5.5	1.53 V	360	62.31	6.19
6	#5744.00	53.8 AV	54.0	-0.2	1.53 V	360	47.61	6.19
7	11220.00	51.4 PK	74.0	-22.6	2.01 V	318	34.47	16.93
8	11220.00	37.4 AV	54.0	-16.6	2.01 V	318	20.47	16.93
9	#16830.00	51.0 PK	74.0	-23.0	1.85 V	353	30.98	20.02
10	#16830.00	38.5 AV	54.0	-15.5	1.85 V	353	18.48	20.02

REMARKS:

- Emission Level(dBuV/m) = Raw Value(dBuV) + Correction Factor(dB/m)
- Correction Factor(dB/m) = Antenna Factor(dB/m) + Cable Factor(dB) – Pre-Amplifier Factor(dB)
- The other emission levels were very low against the limit.
- Margin value = Emission Level – Limit value
- " * ": Fundamental frequency.
- " # ": The radiated frequency is out of the restricted band.

Below 1GHz Data

CDD Mode

802.11ac (VHT40)

CHANNEL	TX Channel 54	DETECTOR FUNCTION	Quasi-Peak (QP)
FREQUENCY RANGE	Below 1GHz		

ANTENNA POLARITY & TEST DISTANCE: HORIZONTAL AT 3 M

NO.	FREQ. (MHz)	EMISSION LEVEL (dBuV/m)	LIMIT (dBuV/m)	MARGIN (dB)	ANTENNA HEIGHT (m)	TABLE ANGLE (Degree)	RAW VALUE (dBuV)	CORRECTION FACTOR (dB/m)
1	166.01	33.0 QP	43.5	-10.5	1.50 H	271	46.35	-13.32
2	218.62	32.0 QP	46.0	-14.0	2.00 H	264	47.82	-15.79
3	327.83	32.6 QP	46.0	-13.4	1.12 H	241	43.70	-11.14
4	500.01	30.6 QP	46.0	-15.4	1.50 H	178	37.45	-6.83
5	608.81	34.5 QP	46.0	-11.5	1.25 H	264	38.42	-3.93
6	713.61	35.4 QP	46.0	-10.6	1.00 H	134	38.02	-2.63

ANTENNA POLARITY & TEST DISTANCE: VERTICAL AT 3 M

NO.	FREQ. (MHz)	EMISSION LEVEL (dBuV/m)	LIMIT (dBuV/m)	MARGIN (dB)	ANTENNA HEIGHT (m)	TABLE ANGLE (Degree)	RAW VALUE (dBuV)	CORRECTION FACTOR (dB/m)
1	60.46	33.2 QP	40.0	-6.8	1.22 V	269	46.92	-13.72
2	93.80	36.9 QP	43.5	-6.6	1.49 V	176	55.27	-18.39
3	237.42	32.1 QP	46.0	-13.9	1.64 V	223	46.70	-14.64
4	320.27	34.4 QP	46.0	-11.6	1.00 V	164	45.76	-11.35
5	418.80	34.3 QP	46.0	-11.7	1.00 V	264	43.07	-8.77
6	566.28	33.2 QP	46.0	-12.8	1.00 V	174	38.82	-5.61

REMARKS:

1. Emission Level(dBuV/m) = Raw Value(dBuV) + Correction Factor(dB/m)
2. Correction Factor(dB/m) = Antenna Factor(dB/m) + Cable Factor(dB) – Pre-Amplifier Factor(dB)
3. The other emission levels were very low against the limit.
4. Margin value = Emission Level – Limit value

4.2 Conducted Emission Measurement

4.2.1 Limits of Conducted Emission Measurement

Frequency (MHz)	Conducted Limit (dBuV)	
	Quasi-peak	Average
0.15 - 0.5	66 - 56	56 - 46
0.50 - 5.0	56	46
5.0 - 30.0	60	50

Note: 1. The lower limit shall apply at the transition frequencies.

2. The limit decreases in line with the logarithm of the frequency in the range of 0.15 to 0.50MHz.

4.2.2 Test Instruments

DESCRIPTION & MANUFACTURER	MODEL NO.	SERIAL NO.	CALIBRATED DATE	CALIBRATED UNTIL
Test Receiver R&S	ESCS 30	100287	Apr. 17, 2015	Apr. 16, 2016
Line-Impedance Stabilization Network (for EUT) SCHWARZBECK	NSLK-8127	8127-523	Oct. 02, 2015	Oct. 01, 2016
Line-Impedance Stabilization Network (for Peripheral) R&S	ENV216	100072	June 11, 2015	June 10, 2016
RF Cable	5D-FB	COACAB-001	May 25, 2015	May 24, 2016
50 ohms Terminator	50	3	Oct. 21, 2015	Oct. 20, 2016
50 ohms Terminator	N/A	EMC-04	Oct. 28, 2015	Oct. 27, 2016
Software BVADT	BVADT_Cond_ V7.3.7.3	NA	NA	NA

Note:

1. The calibration interval of the above test instruments are 12 months and the calibrations are traceable to NML/ROC and NIST/USA.
2. The test was performed in Shielded Room No. A.
3. The VCCI Con A Registration No. is C-817.
4. Tested Date: Nov. 02, 2015

4.2.3 Test Procedure

- a. The EUT was placed 0.4 meters from the conducting wall of the shielded room with EUT being connected to the power mains through a line impedance stabilization network (LISN). Other support units were connected to the power mains through another LISN. The two LISNs provide 50 ohm/ 50uH of coupling impedance for the measuring instrument.
- b. Both lines of the power mains connected to the EUT were checked for maximum conducted interference.
- c. The frequency range from 150kHz to 30MHz was searched. Emission levels under (Limit - 20dB) was not recorded.

NOTE: All modes of operation were investigated and the worst-case emissions are reported.

4.2.4 Deviation from Test Standard

No deviation.

4.2.5 Test Setup

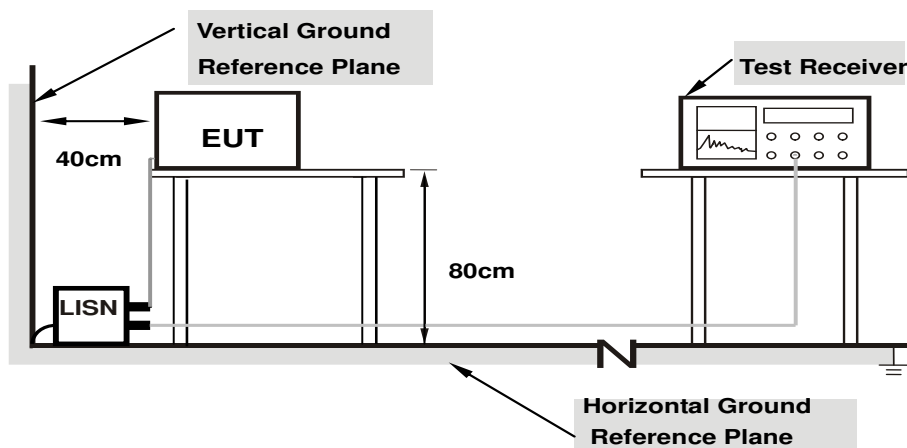

Note: 1.Support units were connected to second LISN.

For the actual test configuration, please refer to the attached file (Test Setup Photo).

4.2.6 EUT Operating Condition

Same as 4.1.6.

4.2.7 Test Results (Mode 2)

CDD Mode

Phase	Line (L)	Detector Function	Quasi-Peak (QP) / Average (AV)
-------	----------	-------------------	--------------------------------

Phase Of Power : Line (L)										
No	Frequency (MHz)	Correction Factor (dB)	Reading Value (dBuV)		Emission Level (dBuV)		Limit (dBuV)		Margin (dB)	
			Q.P.	AV.	Q.P.	AV.	Q.P.	AV.	Q.P.	AV.
1	0.16394	10.32	39.25	27.99	49.57	38.31	65.26	55.26	-15.69	-16.95
2	0.19841	10.34	33.27	21.81	43.61	32.15	63.68	53.68	-20.07	-21.53
3	0.30234	10.37	23.90	14.68	34.27	25.05	60.18	50.18	-25.91	-25.13
4	0.44688	10.40	16.90	4.10	27.30	14.50	56.93	46.93	-29.63	-32.43
5	3.68750	10.64	16.68	6.63	27.32	17.27	56.00	46.00	-28.68	-28.73
6	15.00391	11.28	14.15	9.21	25.43	20.49	60.00	50.00	-34.57	-29.51

Remarks:

1. Q.P. and AV. are abbreviations of quasi-peak and average individually.
2. The emission levels of other frequencies were very low against the limit.
3. Margin value = Emission level – Limit value
4. Correction factor = Insertion loss + Cable loss
5. Emission Level = Correction Factor + Reading Value

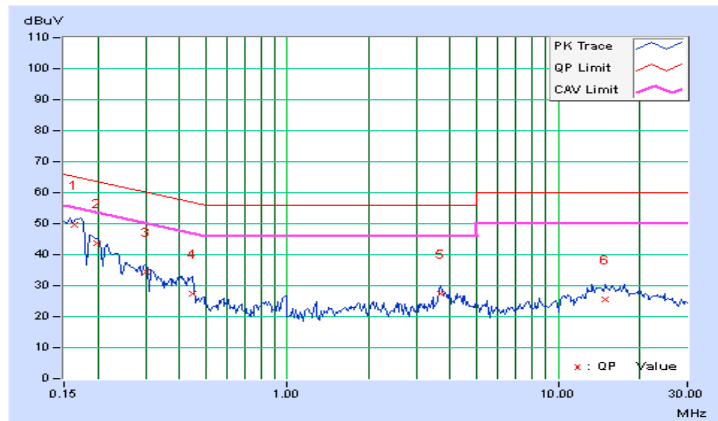

Phase	Neutral (N)	Detector Function	Quasi-Peak (QP) / Average (AV)
-------	-------------	-------------------	--------------------------------

Phase Of Power : Neutral (N)										
No	Frequency (MHz)	Correction Factor (dB)	Reading Value (dBuV)		Emission Level (dBuV)		Limit (dBuV)		Margin (dB)	
			Q.P.	AV.	Q.P.	AV.	Q.P.	AV.	Q.P.	AV.
1	0.16562	10.34	39.41	30.13	49.75	40.47	65.18	55.18	-15.43	-14.71
2	0.20078	10.37	33.39	23.93	43.76	34.30	63.58	53.58	-19.82	-19.28
3	0.26328	10.40	24.86	13.85	35.26	24.25	61.33	51.33	-26.07	-27.08
4	0.40000	10.47	25.64	20.12	36.11	30.59	57.85	47.85	-21.74	-17.26
5	3.73438	10.77	16.61	8.32	27.38	19.09	56.00	46.00	-28.62	-26.91
6	15.33203	11.27	15.37	10.41	26.64	21.68	60.00	50.00	-33.36	-28.32

Remarks:

1. Q.P. and AV. are abbreviations of quasi-peak and average individually.
2. The emission levels of other frequencies were very low against the limit.
3. Margin value = Emission level – Limit value
4. Correction factor = Insertion loss + Cable loss
5. Emission Level = Correction Factor + Reading Value

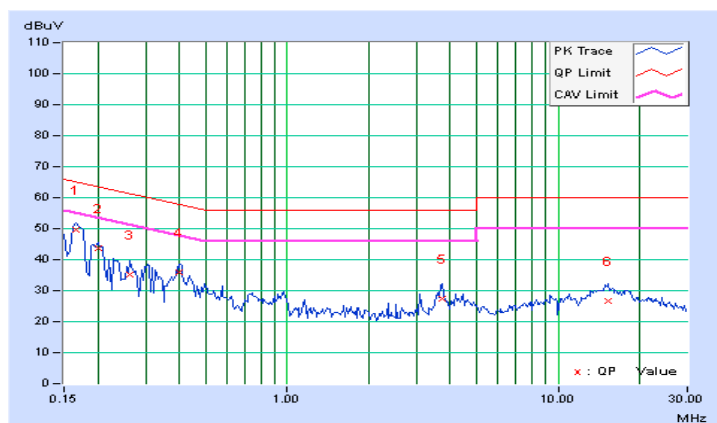

4.2.8 Test Results (Mode 3)

CDD Mode

Phase	Line (L)	Detector Function	Quasi-Peak (QP) / Average (AV)
-------	----------	-------------------	--------------------------------

Phase Of Power : Line (L)										
No	Frequency (MHz)	Correction Factor (dB)	Reading Value (dBuV)		Emission Level (dBuV)		Limit (dBuV)		Margin (dB)	
			Q.P.	AV.	Q.P.	AV.	Q.P.	AV.	Q.P.	AV.
1	0.15000	10.31	38.63	25.47	48.94	35.78	66.00	56.00	-17.06	-20.22
2	0.17734	10.33	35.43	23.45	45.76	33.78	64.61	54.61	-18.85	-20.83
3	0.22031	10.35	31.67	22.13	42.02	32.48	62.81	52.81	-20.79	-20.33
4	0.31016	10.37	37.40	31.01	47.77	41.38	59.97	49.97	-12.19	-8.58
5	0.38438	10.40	24.98	16.18	35.38	26.58	58.18	48.18	-22.81	-21.61
6	3.65625	10.63	12.65	3.53	23.28	14.16	56.00	46.00	-32.72	-31.84

Remarks:

1. Q.P. and AV. are abbreviations of quasi-peak and average individually.
2. The emission levels of other frequencies were very low against the limit.
3. Margin value = Emission level – Limit value
4. Correction factor = Insertion loss + Cable loss
5. Emission Level = Correction Factor + Reading Value

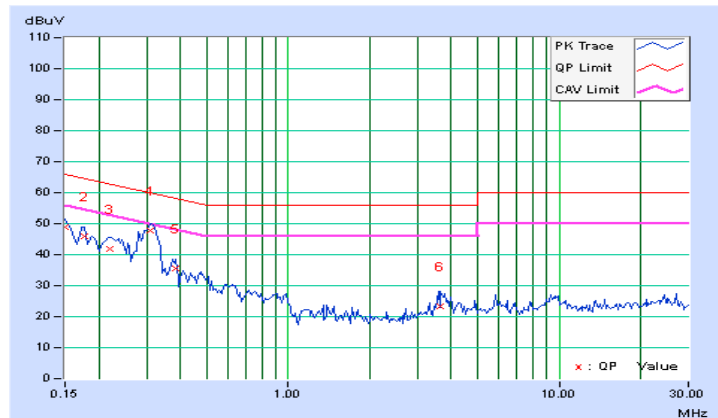

Phase	Neutral (N)	Detector Function	Quasi-Peak (QP) / Average (AV)
-------	-------------	-------------------	--------------------------------

Phase Of Power : Neutral (N)										
No	Frequency (MHz)	Correction Factor (dB)	Reading Value (dBuV)		Emission Level (dBuV)		Limit (dBuV)		Margin (dB)	
			Q.P.	AV.	Q.P.	AV.	Q.P.	AV.	Q.P.	AV.
1	0.16953	10.34	35.35	23.93	45.69	34.27	64.98	54.98	-19.29	-20.71
2	0.22812	10.38	31.14	22.63	41.52	33.01	62.52	52.52	-20.99	-19.50
3	0.31016	10.43	36.09	29.51	46.52	39.94	59.97	49.97	-13.45	-10.03
4	0.38438	10.46	23.66	14.80	34.12	25.26	58.18	48.18	-24.06	-22.92
5	0.58750	10.47	13.59	7.15	24.06	17.62	56.00	46.00	-31.94	-28.38
6	3.75781	10.77	12.48	4.48	23.25	15.25	56.00	46.00	-32.75	-30.75

Remarks:

1. Q.P. and AV. are abbreviations of quasi-peak and average individually.
2. The emission levels of other frequencies were very low against the limit.
3. Margin value = Emission level – Limit value
4. Correction factor = Insertion loss + Cable loss
5. Emission Level = Correction Factor + Reading Value

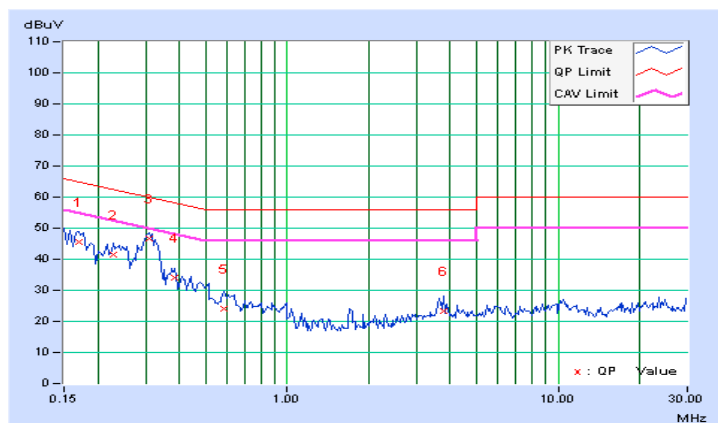

4.2.9 Test Results (Mode 4)

CDD Mode

Phase	Line (L)	Detector Function	Quasi-Peak (QP) / Average (AV)
-------	----------	-------------------	--------------------------------

Phase Of Power : Line (L)										
No	Frequency (MHz)	Correction Factor (dB)	Reading Value (dBuV)		Emission Level (dBuV)		Limit (dBuV)		Margin (dB)	
			Q.P.	AV.	Q.P.	AV.	Q.P.	AV.	Q.P.	AV.
1	0.15000	10.21	41.65	32.53	51.86	42.74	66.00	56.00	-14.14	-13.26
2	0.18125	10.22	34.97	22.71	45.19	32.93	64.43	54.43	-19.23	-21.49
3	0.41522	10.28	30.14	25.82	40.42	36.10	57.54	47.54	-17.12	-11.44
4	13.10547	10.77	26.08	20.74	36.85	31.51	60.00	50.00	-23.15	-18.49
5	17.67578	10.95	25.34	19.94	36.29	30.89	60.00	50.00	-23.71	-19.11
6	28.06250	11.21	27.33	21.91	38.54	33.12	60.00	50.00	-21.46	-16.88

Remarks:

1. Q.P. and AV. are abbreviations of quasi-peak and average individually.
2. The emission levels of other frequencies were very low against the limit.
3. Margin value = Emission level – Limit value
4. Correction factor = Insertion loss + Cable loss
5. Emission Level = Correction Factor + Reading Value

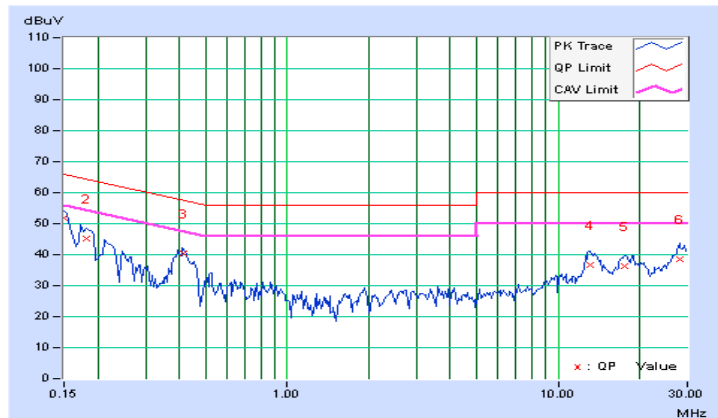

Phase	Neutral (N)	Detector Function	Quasi-Peak (QP) / Average (AV)
-------	-------------	-------------------	--------------------------------

Phase Of Power : Neutral (N)										
No	Frequency (MHz)	Correction Factor (dB)	Reading Value (dBuV)		Emission Level (dBuV)		Limit (dBuV)		Margin (dB)	
			Q.P.	AV.	Q.P.	AV.	Q.P.	AV.	Q.P.	AV.
1	0.15000	10.28	41.19	31.70	51.47	41.98	66.00	56.00	-14.53	-14.02
2	0.18625	10.30	34.52	25.07	44.82	35.37	64.20	54.20	-19.38	-18.83
3	0.41622	10.37	28.99	25.18	39.36	35.55	57.52	47.52	-18.16	-11.97
4	13.38281	10.80	27.26	21.92	38.06	32.72	60.00	50.00	-21.94	-17.28
5	17.69531	10.93	25.45	20.11	36.38	31.04	60.00	50.00	-23.62	-18.96
6	27.96094	11.11	27.09	21.77	38.20	32.88	60.00	50.00	-21.80	-17.12

Remarks:

1. Q.P. and AV. are abbreviations of quasi-peak and average individually.
2. The emission levels of other frequencies were very low against the limit.
3. Margin value = Emission level – Limit value
4. Correction factor = Insertion loss + Cable loss
5. Emission Level = Correction Factor + Reading Value

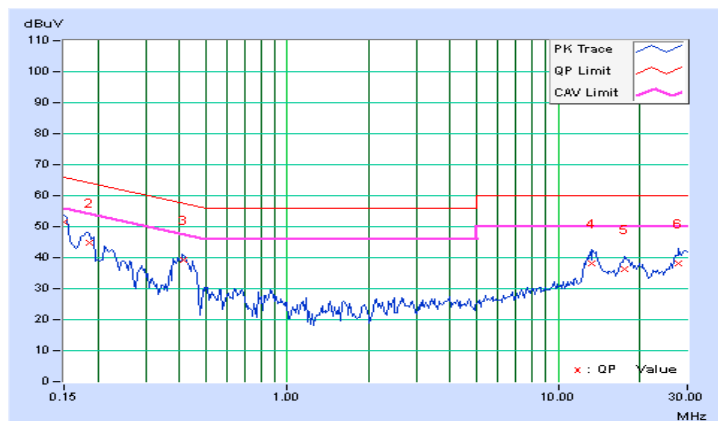

4.3 Transmit Power Measurement

4.3.1 Limits of Transmit Power Measurement

Operation Band	EUT Category		LIMIT
U-NII-1		Outdoor Access Point	1 Watt (30 dBm) (Max. e.i.r.p \leq 125mW(21 dBm) at any elevation angle above 30 degrees as measured from the horizon)
		Fixed point-to-point Access Point	1 Watt (30 dBm)
		Indoor Access Point	1 Watt (30 dBm)
		Mobile and Portable client device	250mW (24 dBm)
U-NII-2A	√		250mW (24 dBm) or 11 dBm+10 log B*
U-NII-2C	√		250mW (24 dBm) or 11 dBm+10 log B*
U-NII-3			1 Watt (30 dBm)

*B is the 26 dB emission bandwidth in megahertz

Per KDB 662911 Method of conducted output power measurement on IEEE 802.11 devices,

Array Gain = 0 dB (i.e., no array gain) for $N_{ANT} \leq 4$;

Array Gain = 0 dB (i.e., no array gain) for channel widths ≥ 40 MHz for any N_{ANT} ;

Array Gain = $5 \log(N_{ANT}/N_{SS})$ dB or 3 dB, whichever is less for 20-MHz channel widths with $N_{ANT} \geq 5$.

For power measurements on all other devices: Array Gain = $10 \log(N_{ANT}/N_{SS})$ dB.

4.3.2 Test Setup

FOR POWER OUTPUT MEASUREMENT

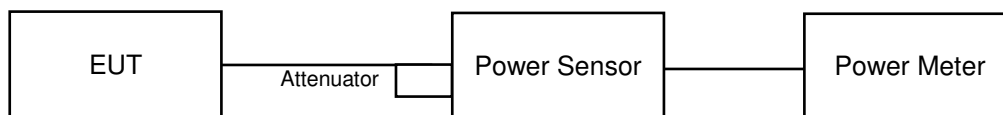

FOR 26dB OCCUPIED BANDWIDTH

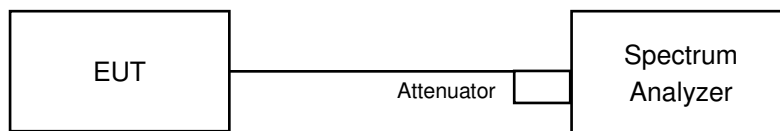

4.3.3 Test Instruments

Refer to section 4.1.2 to get information of above instrument.

4.3.4 Test Procedure

FOR AVERAGE POWER MEASUREMENT

Method PM is used to perform output power measurement, trigger and gating function of wide band power meter with average sensor is enabled to measure max output power of TX on burst. Duty factor is not added to measured value.

FOR 26dB OCCUPIED BANDWIDTH

1. Set RBW = approximately 1% of the emission bandwidth.
2. Set the VBW > RBW.
3. Detector = Peak.
4. Trace mode = max hold.
5. Measure the maximum width of the emission that is 26 dB down from the peak of the emission. Compare this with the RBW setting of the analyzer. Readjust RBW and repeat measurement as needed until the RBW/EBW ratio is approximately 1%.

4.3.5 Deviation from Test Standard

No deviation.

4.3.6 EUT Operating Condition

The software provided by client to enable the EUT under transmission condition continuously at lowest, middle and highest channel frequencies individually.

4.3.7 Test Result
CDD Mode
POWER OUTPUT:

Chan.	Chan. Freq. (MHz)	Maximum Conducted Power (dBm)		Total Power (mW)	Total Power (dBm)	Limit (dBm)	Pass / Fail
		Chain 0	Chain 1				
802.11a							
52	5260	16.01	15.39	74.496	18.72	24	Pass
60	5300	15.59	15.19	69.261	18.40	24	Pass
64	5320	18.09	17.43	119.752	20.78	24	Pass
100	5500	17.68	17.23	111.459	20.47	24	Pass
116	5580	18.10	17.36	119.015	20.76	24	Pass
140	5700	17.95	17.01	112.607	20.52	24	Pass
802.11ac (VHT20)							
52	5260	18.36	17.50	124.783	20.96	24	Pass
60	5300	18.17	17.41	120.696	20.82	24	Pass
64	5320	18.21	17.66	124.567	20.95	24	Pass
100	5500	18.05	17.53	120.45	20.81	24	Pass
116	5580	18.37	17.44	124.17	20.94	24	Pass
140	5700	17.22	16.28	95.185	19.79	24	Pass
802.11ac (VHT40)							
54	5270	20.10	19.65	194.586	22.89	24	Pass
62	5310	14.90	14.38	58.319	17.66	24	Pass
102	5510	14.14	13.46	48.124	16.82	24	Pass
110	5550	19.56	18.59	162.642	22.11	24	Pass
134	5670	17.50	16.54	101.316	20.06	24	Pass
802.11ac (VHT80)							
58	5290	13.39	12.91	41.37	16.17	24	Pass
106	5530	12.75	12.56	36.866	15.67	24	Pass
122	5610	18.78	17.91	137.311	21.38	24	Pass

26dB BANDWIDTH:

Channel	Channel Frequency (MHz)	26dBc Bandwidth (MHz)	
		Chain 0	Chain 1
802.11a			
52	5260	25.15	24.93
60	5300	20.62	20.65
64	5320	31.84	29.38
100	5500	27.24	29.43
116	5580	29.47	30.68
140	5700	27.34	27.84
802.11ac (VHT20)			
52	5260	38.12	34.96
60	5300	34.17	31.89
64	5320	32.67	31.05
100	5500	30.53	30.37
116	5580	32.80	35.45
140	5700	29.21	26.16
802.11ac (VHT40)			
54	5270	94.93	91.82
62	5310	51.45	41.54
102	5510	41.38	41.23
110	5550	80.03	88.21
134	5670	65.44	72.42
802.11ac (VHT80)			
58	5290	83.48	82.92
106	5530	82.62	82.68
122	5610	150.27	152.12

Note: For FCC output power limitation is determined based on 26dB bandwidth.

Power Limit = 11dBm + 10logB < UNII Band 2A~2C>			
Channel Number	Freq.(MHz)	Min. B (MHz)	Determined Conducted Limit (dBm)
802.11a			
52	5260	24.93	24.96 > 24
60	5300	20.62	24.14 > 24
64	5320	29.38	25.68 > 24
100	5500	27.24	25.35 > 24
116	5580	29.47	25.69 > 24
140	5700	27.34	25.36 > 24
802.11ac (VHT20)			
52	5260	34.96	26.43 > 24
60	5300	31.89	26.03 > 24
64	5320	31.05	25.92 > 24
100	5500	30.37	25.82 > 24
116	5580	32.80	26.15 > 24
140	5700	26.16	25.17 > 24
802.11ac (VHT40)			
54	5270	91.82	30.62 > 24
62	5310	41.54	27.18 > 24
102	5510	41.23	27.15 > 24
110	5550	80.03	30.03 > 24
134	5670	65.44	29.15 > 24
802.11ac (VHT80)			
58	5290	82.92	30.18 > 24
106	5530	82.62	30.17 > 24
122	5610	150.27	32.76 > 24

SPECTRUM PLOT OF WORST VALUE

802.11a – Chain (0): CH 60

802.11ac (VHT20) – Chain (1): CH 140

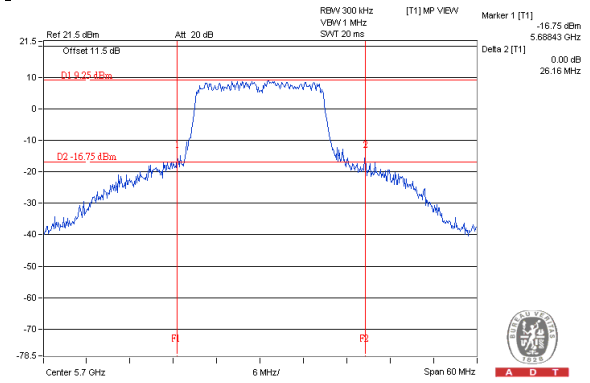
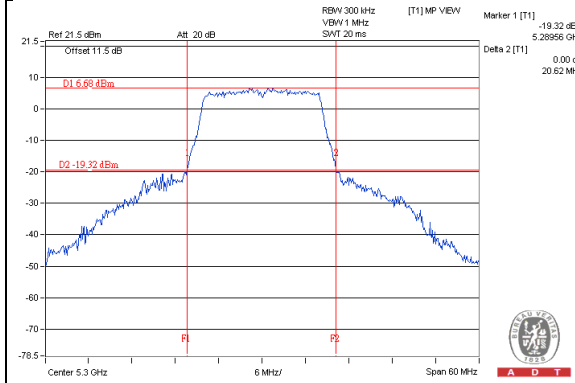

802.11ac (VHT40) – Chain (1): CH 102

802.11ac (VHT80) – Chain (0): CH 106

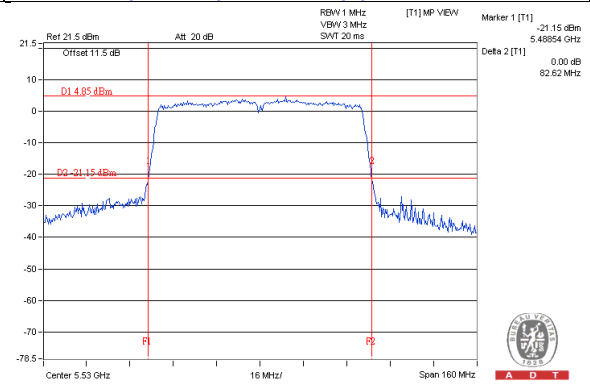
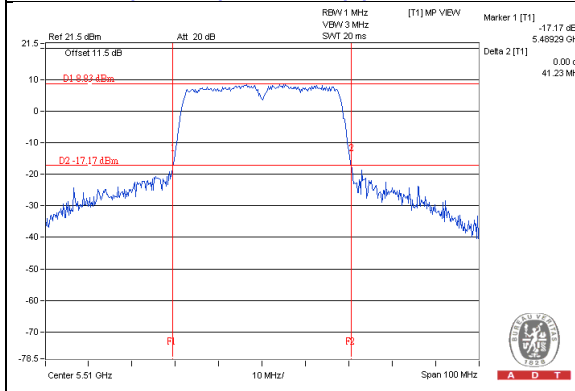

Beamforming Mode
POWER OUTPUT:

Chan.	Chan. Freq. (MHz)	Maximum Conducted Power (dBm)		Total Power (mW)	Total Power (dBm)	Limit (dBm)	Pass / Fail
		Chain 0	Chain 1				
802.11ac (VHT20)							
52	5260	18.36	17.50	124.783	20.96	20.99	Pass
60	5300	18.17	17.41	120.696	20.82	20.99	Pass
64	5320	18.21	17.66	124.567	20.95	20.99	Pass
100	5500	18.05	17.53	120.45	20.81	20.99	Pass
116	5580	18.37	17.44	124.17	20.94	20.99	Pass
140	5700	17.22	16.28	95.185	19.79	20.99	Pass
802.11ac (VHT40)							
54	5270	17.32	18.44	123.774	20.93	20.99	Pass
62	5310	14.90	14.38	58.319	17.66	20.99	Pass
102	5510	14.14	13.46	48.124	16.82	20.99	Pass
110	5550	18.33	17.38	122.779	20.89	20.99	Pass
134	5670	17.50	16.54	101.316	20.06	20.99	Pass
802.11ac (VHT80)							
58	5290	13.39	12.91	41.37	16.17	20.99	Pass
106	5530	12.75	12.56	36.866	15.67	20.99	Pass
122	5610	18.32	17.50	124.154	20.94	20.99	Pass

Note: 1. Directional gain = 6dBi + 10log(2) = 9.01dBi > 6dBi, so the power limit shall be reduced to "Determined Conducted Limit-(9.01-6)"

26dB BANDWIDTH:

Channel	Channel Frequency (MHz)	26dBc Bandwidth (MHz)	
		Chain 0	Chain 1
802.11ac (VHT20)			
52	5260	38.12	34.96
60	5300	34.17	31.89
64	5320	32.67	31.05
100	5500	30.53	30.37
116	5580	32.80	35.45
140	5700	29.21	26.16
802.11ac (VHT40)			
54	5270	94.93	91.82
62	5310	51.45	41.54
102	5510	41.38	41.23
110	5550	41.79	88.21
134	5670	65.44	72.42
802.11ac (VHT80)			
58	5290	83.48	82.92
106	5530	82.62	82.68
122	5610	150.27	152.12

Note: For FCC output power limitation is determined based on 26dB bandwidth.

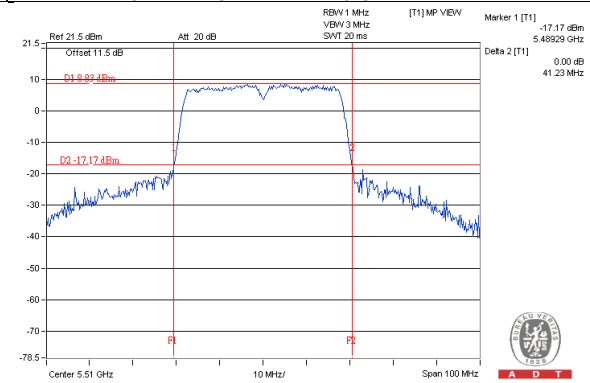
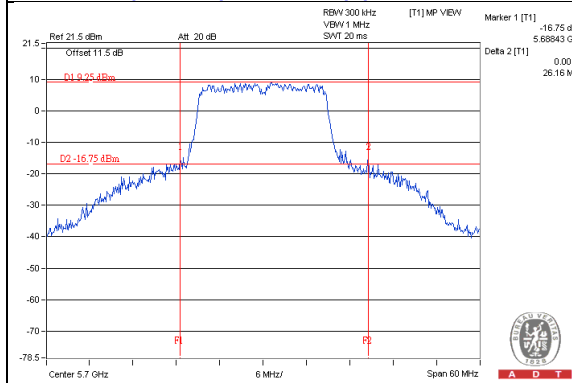
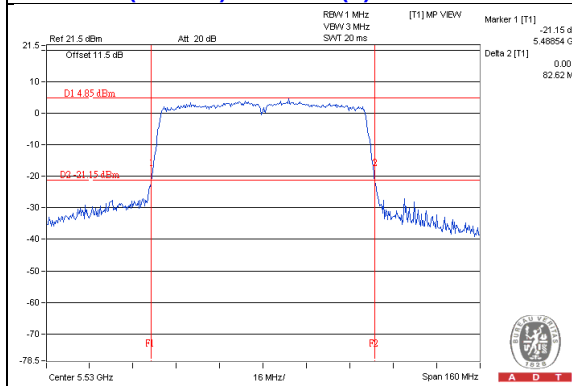

Power Limit = 11dBm + 10logB < UNII Band 2A~2C>			
Channel Number	Freq.(MHz)	Min. B (MHz)	Determined Conducted Limit (dBm)
802.11ac (VHT20)			
52	5260	34.96	26.43 > 24
60	5300	31.89	26.03 > 24
64	5320	31.05	25.92 > 24
100	5500	30.37	25.82 > 24
116	5580	32.80	26.15 > 24
140	5700	26.16	25.17 > 24
802.11ac (VHT40)			
54	5270	91.82	30.62 > 24
62	5310	41.54	27.18 > 24
102	5510	41.23	27.15 > 24
110	5550	41.79	27.21 > 24
134	5670	65.44	29.15 > 24
802.11ac (VHT80)			
58	5290	82.92	30.18 > 24
106	5530	82.62	30.17 > 24
122	5610	150.27	32.76 > 24

SPECTRUM PLOT OF WORST VALUE**802.11ac (VHT20) – Chain (1): CH 140****802.11ac (VHT40) – Chain (1): CH 102****802.11ac (VHT80) – Chain (0): CH 106**

4.4 Peak Power Spectral Density Measurement

4.4.1 Limits of Peak Power Spectral Density Measurement

Operation Band	EUT Category		LIMIT
U-NII-1		Outdoor Access Point	17dBm/ MHz
		Fixed point-to-point Access Point	
		Indoor Access Point	
		Mobile and Portable client device	11dBm/ MHz
U-NII-2A	√		11dBm/ MHz
U-NII-2C	√		11dBm/ MHz
U-NII-3			30dBm/ 500kHz

4.4.2 Test Setup

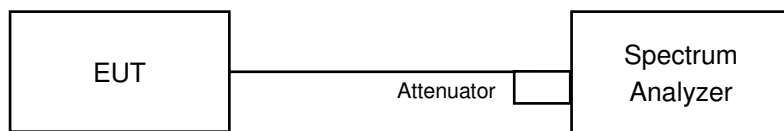

4.4.3 Test Instruments

Refer to section 4.1.2 to get information of above instrument.

4.4.4 Test Procedure

For 802.11a, 802.11ac (VHT20) & 802.11ac (VHT40)

Using method SA-1

1. Set span to encompass the entire emission bandwidth (EBW) of the signal.
2. Set RBW = 1 MHz, Set VBW ≥ 3 MHz, Detector = RMS
3. Sweep time = auto, trigger set to “free run”.
4. Trace average at least 100 traces in power averaging mode.
5. Record the max value

For 802.11ac (VHT80)

Using method SA-2

1. Set span to encompass the entire emission bandwidth (EBW) of the signal.
2. Set RBW = 1 MHz, Set VBW ≥ 3 MHz, Detector = RMS
3. Sweep time = auto, trigger set to “free run”.
4. Trace average at least 100 traces in power averaging mode.
5. Record the max value and add 10 log (1/duty cycle)

4.4.5 Deviation from Test Standard

No deviation.

4.4.6 EUT Operating Condition

Same as Item 4.3.6.

4.4.7 Test Results

CDD Mode

Chan.	Chan. Freq. (MHz)	PSD (dBm/MHz)		Total Power Density (dBm/MHz)	MAX. Limit (dBm/MHz)	Pass / Fail
		Chain 0	Chain 1			
802.11a						
52	5260	2.60	2.41	5.52	7.99	Pass
60	5300	1.71	2.15	4.95	7.99	Pass
64	5320	4.67	5.06	7.88	7.99	Pass
100	5500	4.02	4.64	7.35	7.99	Pass
116	5580	4.32	5.33	7.86	7.99	Pass
140	5700	3.85	4.30	7.09	7.99	Pass
802.11ac (VHT20)						
52	5260	4.45	5.10	7.80	7.99	Pass
60	5300	4.26	5.28	7.81	7.99	Pass
64	5320	4.48	5.09	7.81	7.99	Pass
100	5500	4.44	5.22	7.86	7.99	Pass
116	5580	4.61	5.18	7.91	7.99	Pass
140	5700	3.03	3.41	6.23	7.99	Pass
802.11ac (VHT40)						
54	5270	2.70	2.00	5.37	7.99	Pass
62	5310	-1.97	-1.73	1.16	7.99	Pass
102	5510	-2.72	-2.71	0.30	7.99	Pass
110	5550	2.90	3.09	4.07	7.99	Pass
134	5670	0.39	0.49	3.45	7.99	Pass

Note: 1. Method a) of power density measurement of KDB 662911 is using for calculating total power density. Total power density is summing entire spectra across corresponding frequency bins on the various outputs by computer.

2. Directional gain = $6\text{dBi} + 10\log(2) = 9.01\text{dBi} > 6\text{dBi}$, so the power density limit shall be reduced to $11 - (9.01 - 6) = 7.99\text{dBm}$.

Chan.	Chan. Freq. (MHz)	PSD w/o duty factor (dBm/MHz)		Duty Factor (dB)	Total PSD with Duty Factor (dBm/MHz)	MAX. Limit (dBm/MHz)	Pass / Fail
		Chain 0	Chain 1				
802.11ac (VHT80)							
58	5290	-6.54	-6.36	0.38	-3.06	7.99	Pass
106	5530	-7.21	-6.95	0.38	-3.69	7.99	Pass
122	5610	-1.77	-1.44	0.38	1.79	7.99	Pass

- Note: 1. Method a) of power density measurement of KDB 662911 is using for calculating total power density. Total power density is summing entire spectra across corresponding frequency bins on the various outputs by computer.
2. Directional gain = $6\text{dBi} + 10\log(2) = 9.01\text{dBi} > 6\text{dBi}$, so the power density limit shall be reduced to $11 - (9.01 - 6) = 7.99\text{dBm}$.
3. Refer to section 3.3 for duty cycle spectrum plot.

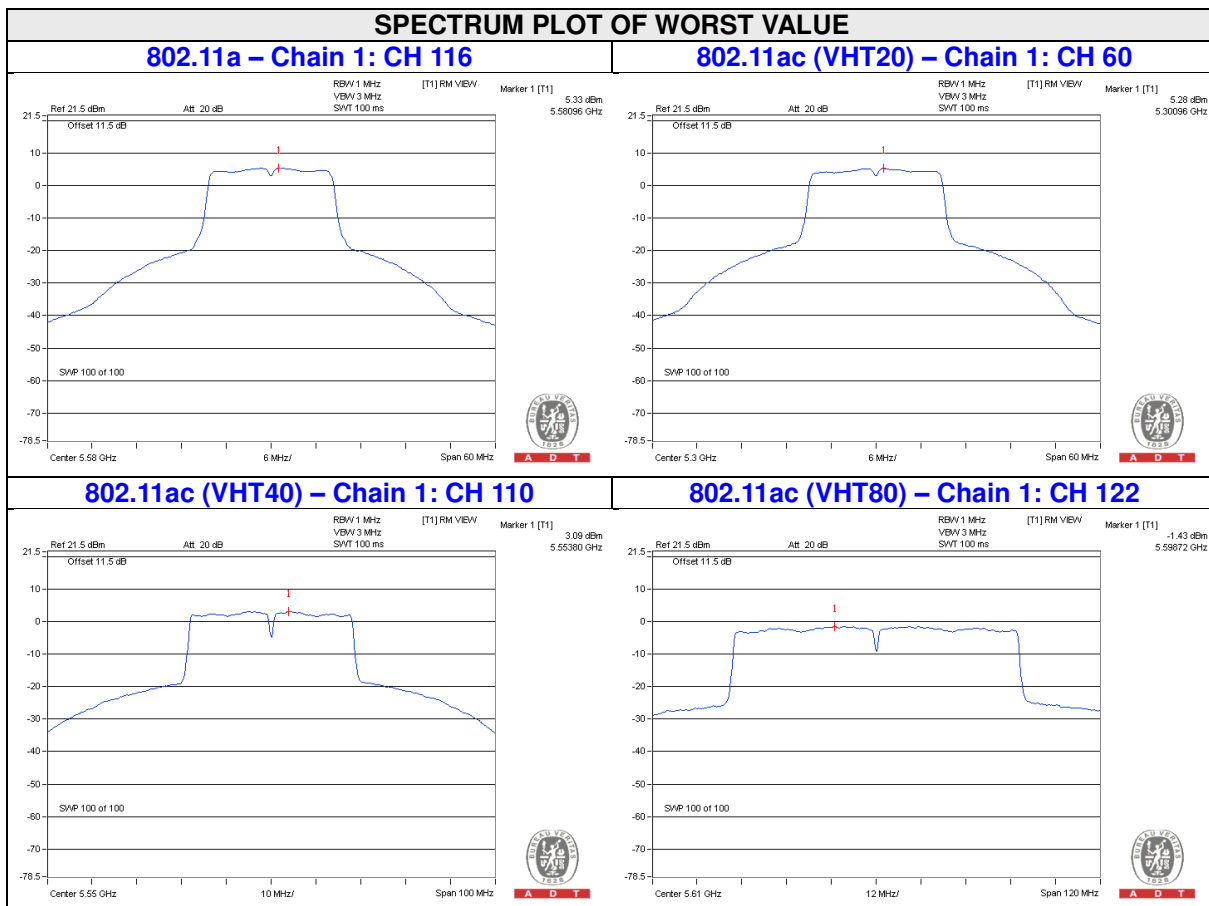

4.5 Frequency Stability Measurement

4.5.1 Limits of Frequency Stability Measurement

The frequency of the carrier signal shall be maintained within band of operation

4.5.2 Test Setup

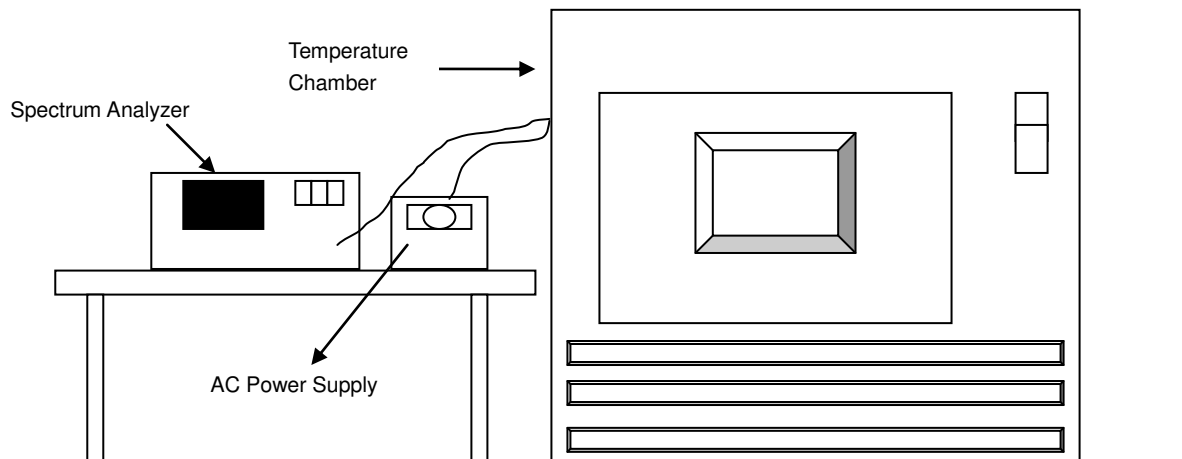

4.5.3 Test Instruments

Refer to section 4.1.2 to get information of above instrument.

4.5.4 Test Procedure

- a. The EUT was placed inside the environmental test chamber and powered by nominal AC voltage.
- b. Turn the EUT on and couple its output to a spectrum analyzer.
- c. Turn the EUT off and set the chamber to the highest temperature specified.
- d. Allow sufficient time (approximately 30 min) for the temperature of the chamber to stabilize, turn the EUT on and measure the operating frequency after 2, 5, and 10 minutes.
- e. Repeat step 2 and 3 with the temperature chamber set to the lowest temperature.
- f. The test chamber was allowed to stabilize at +20 degree C for a minimum of 30 minutes. The supply voltage was then adjusted on the EUT from 85% to 115% and the frequency record.

4.5.5 Deviation from Test Standard

No deviation.

4.5.6 EUT Operating Condition

Set the EUT transmit at un-modulation mode to test frequency stability.

4.5.7 Test Results

FREQUENCY STABILITY VERSUS TEMP.									
OPERATING FREQUENCY: 5260MHz									
TEMP. (°C)	POWER SUPPLY (Vac)	0 MINUTE		2 MINUTE		5 MINUTE		10 MINUTE	
		Measured Frequency (MHz)	Frequency Drift (%)	Measured Frequency (MHz)	Frequency Drift (%)	Measured Frequency (MHz)	Frequency Drift (%)	Measured Frequency (MHz)	Frequency Drift (%)
50	120	5259.9806	-0.00037	5259.9849	-0.00029	5259.9849	-0.00029	5259.9811	-0.00036
40	120	5260.0006	0.00001	5260.0037	0.00007	5260.0018	0.00003	5260.0005	0.00001
30	120	5259.9866	-0.00025	5259.9854	-0.00028	5259.9885	-0.00022	5259.9873	-0.00024
20	120	5259.9881	-0.00023	5259.9876	-0.00024	5259.9922	-0.00015	5259.9875	-0.00024
10	120	5259.9845	-0.00029	5259.9882	-0.00022	5259.9878	-0.00023	5259.987	-0.00025
0	120	5259.9768	-0.00044	5259.9748	-0.00048	5259.9798	-0.00038	5259.9779	-0.00042
-10	120	5259.9947	-0.00010	5259.9967	-0.00006	5259.9978	-0.00004	5259.9957	-0.00008
-20	120	5259.9911	-0.00017	5259.9915	-0.00016	5259.9915	-0.00016	5259.9952	-0.00009
-30	120	5259.9902	-0.00019	5259.9935	-0.00012	5259.9888	-0.00021	5259.9909	-0.00017

FREQUENCY STABILITY VERSUS VOLTAGE									
OPERATING FREQUENCY: 5260MHz									
TEMP. (°C)	POWER SUPPLY (Vac)	0 MINUTE		2 MINUTE		5 MINUTE		10 MINUTE	
		Measured Frequency (MHz)	Frequency Drift (%)	Measured Frequency (MHz)	Frequency Drift (%)	Measured Frequency (MHz)	Frequency Drift (%)	Measured Frequency (MHz)	Frequency Drift (%)
20	138	5259.9871	-0.00025	5259.988	-0.00023	5259.9914	-0.00016	5259.9872	-0.00024
	120	5259.9881	-0.00023	5259.9876	-0.00024	5259.9922	-0.00015	5259.9875	-0.00024
	102	5259.9889	-0.00021	5259.9885	-0.00022	5259.9916	-0.00016	5259.9871	-0.00025

5 Pictures of Test Arrangements

Please refer to the attached file (Test Setup Photo).



A D T

Appendix – Information on the Testing Laboratories

We, Bureau Veritas Consumer Products Services (H.K.) Ltd., Taoyuan Branch, were founded in 1988 to provide our best service in EMC, Radio, Telecom and Safety consultation. Our laboratories are accredited and approved according to ISO/IEC 17025.

If you have any comments, please feel free to contact us at the following:

Linko EMC/RF Lab

Tel: 886-2-26052180

Fax: 886-2-26051924

Hsin Chu EMC/RF Lab/Telecom Lab

Tel: 886-3-5935343

Fax: 886-3-5935342

Hwa Ya EMC/RF/Safety

Tel: 886-3-3183232

Fax: 886-3-3270892

Email: service.adt@tw.bureauveritas.com

Web Site: www.bureauveritas-adt.com

The address and road map of all our labs can be found in our web site also.

--- END ---