



DFS TEST REPORT (Master mode)

REPORT NO.: RF141117E18K-2

MODEL NO.: EX3800

FCC ID: PY315300318

RECEIVED: Nov. 17, 2014

TESTED: May 27, 2015

ISSUED: Feb. 02, 2016

APPLICANT: NETGEAR, Inc.

ADDRESS: 350 East Plumeria Drive San Jose, CA 95134

ISSUED BY: Bureau Veritas Consumer Products Services (H.K.)
Ltd., Taoyuan Branch Hsin Chu Laboratory

LAB ADDRESS : E-2, No.1, Li Hsin 1st Road, Hsinchu Science Park,
Hsinchu City 300, Taiwan R.O.C.



This report is for your exclusive use. Any copying or replication of this report to or for any other person or entity, or use of our name or trademark, is permitted only with our prior written permission. This report sets forth our findings solely with respect to the test samples identified herein. The results set forth in this report are not indicative or representative of the quality or characteristics of the lot from which a test sample was taken or any similar or identical product unless specifically and expressly noted. Our report includes all of the tests requested by you and the results thereof based upon the information that you provided to us. You have 60 days from date of issuance of this report to notify us of any material error or omission caused by our negligence, provided, however, that such notice shall be in writing and shall specifically address the issue you wish to raise. A failure to raise such issue within the prescribed time shall constitute your unqualified acceptance of the completeness of this report, the tests conducted and the correctness of the report contents. Unless specific mention, the uncertainty of measurement has been explicitly taken into account to declare the compliance or non-compliance to the specification. The report must not be used by the client to claim product certification.



Table of Contents

RELEASE CONTROL RECORD.....	3
1. CERTIFICATION	4
2. EUT INFORMATION.....	5
2.1 OPERATING FREQUENCY BANDS AND MODE OF EUT	5
2.2 EUT SOFTWARE AND FIRMWARE VERSION	5
2.3 DESCRIPTION OF AVAILABLE ANTENNAS TO THE EUT	6
2.4 EUT MAXIMUM CONDUCTED POWER.....	7
2.5 EUT MAXIMUM EIRP POWER	8
2.6 TRANSMIT POWER CONTROL (TPC) MECHANISM.....	9
2.7 STATEMENT OF MANUFACTURER	9
3. U-NII DFS RULE REQUIREMENTS	10
3.1 WORKING MODES AND REQUIRED TEST ITEMS	10
3.2 TEST LIMITS AND RADAR SIGNAL PARAMETERS	12
4. TEST & SUPPORT EQUIPMENT LIST	15
4.1 TEST INSTRUMENTS	15
4.2 DESCRIPTION OF SUPPORT UNITS	15
5. TEST PROCEDURE	16
5.1 DFS MEASUREMENT SYSTEM:.....	16
5.2 CALIBRATION OF DFS DETECTION THRESHOLD LEVEL:.....	17
5.3 DEVIATION FROM TEST STANDARD	17
5.4 CONDUCTED TEST SETUP CONFIGURATION.....	18
6. TEST RESULTS	19
6.1 SUMMARY OF TEST RESULT	19
6.2 DETAILED TEST RESULTS.....	20
6.2.1. TEST MODE: DEVICE OPERATING IN MASTER MODE.....	20
6.2.1.1 DFS DETECTION THRESHOLD	20
6.2.1.2 CHANNEL AVAILABILITY CHECK TIME.....	29
6.2.1.3 CHANNEL CLOSING TRANSMISSION AND CHANNEL MOVE TIME.....	31
6.2.1.4 NON- OCCUPANCY PERIOD	66
6.2.1.6 U-NII DETECTION BANDWIDTH.....	68
6.2.1.7 NON-CO-CHANNEL TEST.....	75
7. INFORMATION ON THE TESTING LABORATORIES	76
8. APPENDIX A - MODIFICATIONS RECORDERS FOR ENGINEERING CHANGES TO THE EUT BY THE LAB.....	77
9. APPENDIX-B.....	78



A D T

RELEASE CONTROL RECORD

ISSUE NO.	REASON FOR CHANGE	DATE ISSUED
RF141117E18K-2	Original release	Feb. 02, 2016



A D T

1. CERTIFICATION

PRODUCT: AC750 Universal Pass Through WiFi Range Extender
BRAND NAME: NETGEAR
MODEL NO.: EX3800
TEST SAMPLE: ENGINEERING SAMPLE
APPLICANT: NETGEAR, Inc.
TESTED: May 27, 2015
STANDARDS: FCC Part 15, Subpart E (Section 15.407)
KDB 905462 D02 UNII DFS Compliance Procedures
New Rules v01r02

The above equipment (Model: EX3800) has been tested by **Bureau Veritas Consumer Products Services (H.K.) Ltd., Taoyuan Branch**, and was in compliance with the requirement of the above standards. The test record, data evaluation & Equipment Under Test (EUT) configurations represented herein are true and accurate accounts of the measurements of the sample's EMC characteristics under the conditions specified in this report.

Prepared by :  , **Date:** Feb. 02, 2016
(Lori Chung, Specialist)

Approved by :  , **Date:** Feb. 02, 2016
(May Chen, Manager)

2. EUT INFORMATION

2.1 OPERATING FREQUENCY BANDS AND MODE OF EUT

TABLE 1: OPERATING FREQUENCY BANDS AND MODE OF EUT

Operational Mode	Operating Frequency Range	
	5250~5350MHz	5470~5725MHz
Master	✓	✓

2.2 EUT SOFTWARE AND FIRMWARE VERSION

TABLE 2: THE EUT SOFTWARE/FIRMWARE VERSION

No.	Product	Model No.	Software/Firmware Version
1	AC750 Universal Pass Through WiFi Range Extender	EX3800	V1.0.0.28_1.0.20_DFS_Cert



2.3 DESCRIPTION OF AVAILABLE ANTENNAS TO THE EUT

TABLE 3: ANTENNA LIST

Ant. No.	Brand	Model	Antenna Gain(dBi) <including cable loss>	Frequency range (GHz ~ GHz)	Antenna Type	Connector Type	Cable Length (mm)
Antenna R	NETGEAR	NA	3.1	2.4~2.4835	Dipole	i-pex (MHF)	35
			3	5.15~5.25			
			3.2	5.25~5.35			
			3.2	5.47~5.725			
			3.3	5.725~5.85			
Antenna L	NETGEAR	NA	3.2	2.4~2.4835	Dipole	i-pex (MHF)	75
			4	5.15~5.25			
			4	5.25~5.35			
			3.9	5.47~5.725			
			3.1	5.725~5.85			

2.4 EUT MAXIMUM CONDUCTED POWER

TABLE 4: THE MEASURED CONDUCTED OUTPUT POWER

802.11a

Frequency Band (MHz)	MAX. Power		MIN. Power	
	Output Power (dBm)	Output Power (mW)	Output Power (dBm)	Output Power (mW)
5250~5350	23.61	229.631	17.61	57.677
5470~5725	23.63	230.706	17.63	57.943

802.11ac (VHT20)

Frequency Band (MHz)	MAX. Power		MIN. Power	
	Output Power (dBm)	Output Power (mW)	Output Power (dBm)	Output Power (mW)
5250~5350	23.50	223.889	17.50	56.234
5470~5725	23.40	218.54	17.40	54.954

802.11ac (VHT40)

Frequency Band (MHz)	MAX. Power		MIN. Power	
	Output Power (dBm)	Output Power (mW)	Output Power (dBm)	Output Power (mW)
5250~5350	23.93	246.925	17.93	62.087
5470~5725	23.97	249.476	17.97	62.661

802.11ac (VHT80)

Frequency Band (MHz)	MAX. Power		MIN. Power	
	Output Power (dBm)	Output Power (dBm)	Output Power (mW)	Output Power (mW)
5250~5350	17.60	57.558	11.6	14.454
5470~5725	21.90	154.717	15.9	38.905



2.5 EUT MAXIMUM EIRP POWER

TABLE 5: THE EIRP OUTPUT POWER LIST

802.11a

Frequency Band (MHz)	MAX. Power		MIN. Power	
	Output Power (dBm)	Output Power (mW)	Output Power (dBm)	Output Power (mW)
5250~5350	27.61	576.807	21.61	144.877
5470~5725	27.53	566.316	21.53	142.233

802.11ac (VHT20)

Frequency Band (MHz)	MAX. Power		MIN. Power	
	Output Power (dBm)	Output Power (mW)	Output Power (dBm)	Output Power (mW)
5250~5350	27.50	562.384	21.50	141.254
5470~5725	27.30	536.452	21.30	134.896

802.11ac (VHT40)

Frequency Band (MHz)	MAX. Power		MIN. Power	
	Output Power (dBm)	Output Power (mW)	Output Power (dBm)	Output Power (mW)
5250~5350	27.93	620.248	21.93	155.955
5470~5725	27.87	612.391	21.87	153.815

802.11ac (VHT80)

Frequency Band (MHz)	MAX. Power		MIN. Power	
	Output Power (dBm)	Output Power (mW)	Output Power (dBm)	Output Power (mW)
5250~5350	21.60	144.579	15.60	36.308
5470~5725	25.80	379.785	19.80	95.499

2.6 TRANSMIT POWER CONTROL (TPC) MECHANISM

U-NII devices operating in the 5.25-5.35 GHz band and the 5.47-5.725 GHz band shall employ a TPC mechanism. The U-NII device is required to have the capability to operate at least 6 dB below the mean EIRP value of 30 dBm. A TPC mechanism is not required for systems with an EIRP of less than 500 mW.

Maximum EIRP of this device is 620.248mW which more than 500mW, therefore it's require TPC function.

The UUT can adjust a transmitter's output power based on the signal level present at the receiver.

TPC is controlled by software and the user may adjust the Transmit Power level from web interface that may adjust the transmit power among Max, -3dB, -6dB, from web manually when the power needs to be increased or decreased.

2.7 STATEMENT OF MANUFACTURER

Manufacturer statement confirming that information regarding the parameters of the detected Radar Waveforms is not available to the end user.



3. U-NII DFS RULE REQUIREMENTS

3.1 WORKING MODES AND REQUIRED TEST ITEMS

The manufacturer shall state whether the UUT is capable of operating as a Master and/or a Client. If the UUT is capable of operating in more than one operating mode then each operating mode shall be tested separately. See tables 6 and 7 for the applicability of DFS requirements for each of the operational modes.

TABLE 6: APPLICABILITY OF DFS REQUIREMENTS PRIOR TO USE A CHANNEL

Requirement	Operational Mode		
	Master	Client without radar detection	Client with radar detection
Non-Occupancy Period	✓	Not required	✓
DFS Detection Threshold	✓	Not required	✓
Channel Availability Check Time	✓	Not required	Not required
U-NII Detection Bandwidth	✓	Not required	✓



A D T

TABLE 7: APPLICABILITY OF DFS REQUIREMENTS DURING NORMAL OPERATION

Requirement	Operational Mode	
	Master or Client with radar detection	Client without radar detection
DFS Detection Threshold	✓	Not required
Channel Closing Transmission Time	✓	✓
Channel Move Time	✓	✓
U-NII Detection Bandwidth	✓	Not required

Additional requirements for devices with multiple bandwidth modes	Master or Client with radar detection	Client without radar detection
U-NII Detection Bandwidth and Statistical Performance Check	All BW modes must be tested	Not required
Channel Move Time and Channel Closing Transmission Time	Test using widest BW mode available	Test using the widest BW mode available for the link
All other tests	Any single BW mode	Not required

Note: Frequencies selected for statistical performance check (Section 7.8.4 of KDB) should include several frequencies within the radar detection bandwidth and frequencies near the edge of the radar detection bandwidth. For 802.11 devices it is suggested to select frequencies in each of the bonded 20 MHz channels and the channel center frequency.

3.2 TEST LIMITS AND RADAR SIGNAL PARAMETERS

DETECTION THRESHOLD VALUES

TABLE 8: DFS DETECTION THRESHOLDS FOR MASTER DEVICES AND CLIENT DEVICES WITH RADAR DETECTION

Maximum Transmit Power	Value (See Notes 1, 2, and 3)
EIRP \geq 200 milliwatt	-64 dBm
EIRP < 200 milliwatt and power spectral density < 10 dBm/MHz	-62 dBm
EIRP < 200 milliwatt that do not meet the power spectral density requirement	-64 dBm

Note 1: This is the level at the input of the receiver assuming a 0 dBi receive antenna.
 Note 2: Throughout these test procedures an additional 1 dB has been added to the amplitude of the test transmission waveforms to account for variations in measurement equipment. This will ensure that the test signal is at or above the detection threshold level to trigger a DFS response.
 Note3: EIRP is based on the highest antenna gain. For MIMO devices refer to KDB Publication 662911 D01.

TABLE 9: DFS RESPONSE REQUIREMENT VALUES

Parameter	Value
Non-occupancy period	Minimum 30 minutes
Channel Availability Check Time	60 seconds
Channel Move Time	10 seconds See Note 1.
Channel Closing Transmission Time	200 milliseconds + an aggregate of 60 milliseconds over remaining 10 second period. See Notes 1 and 2.
U-NII Detection Bandwidth	Minimum 100% of the U-NII 99% transmission power bandwidth. See Note 3

Note 1: Channel Move Time and the Channel Closing Transmission Time should be performed with Radar Type 0. The measurement timing begins at the end of the Radar Type 0 burst.
 Note 2: The Channel Closing Transmission Time is comprised of 200 milliseconds starting at the beginning of the Channel Move Time plus any additional intermittent control signals required to facilitate a Channel move (an aggregate of 60 milliseconds) during the remainder of the 10 second period. The aggregate duration of control signals will not count quiet periods in between transmissions.
 Note 3: During the U-NII Detection Bandwidth detection test, radar type 0 should be used. For each frequency step the minimum percentage of detection is 90 percent. Measurements are performed with no data traffic.



A D T

PARAMETERS OF DFS TEST SIGNALS

Step intervals of 0.1 microsecond for Pulse Width, 1 microsecond for PRI, 1 MHz for chirp width and 1 for the number of pulses will be utilized for the random determination of specific test waveforms.

TABLE 10: SHORT PULSE RADAR TEST WAVEFORMS

Radars Type	Pulse Width (μsec)	PRI (μsec)	Number of Pulses	Minimum Percentage of Successful Detection	Minimum Number of Trials
0	1	1428	18	See Note 1	See Note 1
1	1	Test A: 15 unique PRI values randomly selected from the list of 23 PRI values in Table 5a <hr/> Test B: 15 unique PRI values randomly selected within the range of 518-3066 μ sec, with a minimum increment of 1 μ sec, excluding PRI values selected in Test A	$\text{Roundup} \left\{ \begin{array}{l} \left(\frac{1}{360} \right) \\ \left(\frac{19 \cdot 10^6}{\text{PRI}_{\mu\text{sec}}} \right) \end{array} \right\}$	60%	30
2	1-5	150-230	23-29	60%	30
3	6-10	200-500	16-18	60%	30
4	11-20	200-500	12-16	60%	30
Aggregate (Radars Types 1-4)				80%	120
Note 1: Short Pulse Radar Type 0 should be used for the detection bandwidth test, channel move time, and channel closing time tests.					



A D T

TABLE 11: LONG PULSE RADAR TEST WAVEFORM

Radar Type	Pulse Width (μsec)	Chirp Width (MHz)	PRI (μsec)	Number of Pulses per Burst	Number of Bursts	Minimum Percentage of Successful Detection	Minimum Number of Trials
5	50-100	5-20	1000-2000	1-3	8-20	80%	30

TABLE 12: FREQUENCY HOPPING RADAR TEST WAVEFORM

Radar Type	Pulse Width (μsec)	PRI (μsec)	Pulses per Hop	Hopping Rate (kHz)	Hopping Sequence Length (msec)	Minimum Percentage of Successful Detection	Minimum Number of Trials
6	1	333	9	0.333	300	70%	30



A D T

4. TEST & SUPPORT EQUIPMENT LIST

4.1 TEST INSTRUMENTS

TABLE 13: TEST INSTRUMENTS LIST

DESCRIPTION & MANUFACTURER	MODEL NO.	SERIAL NO.	CALIBRATED DATE	CALIBRATED UNTIL
Spectrum Analyzer R&S	FSP40	100036	Jan. 22, 2015	Jan. 21, 2016
Vector Signal Generator R&S	SMJ100A	101878	Aug. 12, 2014	Aug. 11, 2015

4.2 DESCRIPTION OF SUPPORT UNITS

TABLE 14: SUPPORT UNIT INFORMATION

No.	Product	Brand	Model No.	FCC ID	Spec.
1	Wireless LAN Unit	NEC	NP05LM	RRK-NECNP05LM	

NOTE: This device was functioned as a Master Slave device during the DFS test.

TABLE 15: SOFTWARE/FIRMWARE INFORMATION

No.	Product	Model No.	Software/Firmware Version
1	Wireless LAN Unit	NP05LM	Driver Version: 06/18/2014, 1026.12.606.2014

5. TEST PROCEDURE

5.1 DFS MEASUREMENT SYSTEM:

A complete DFS Measurement System consists of Radar signal generate system to generating the radar waveforms in Table 10, 11 and 12. The traffic monitoring system is specified to the type of unit under test (UUT).

Conducted setup configuration of DFS Measurement System

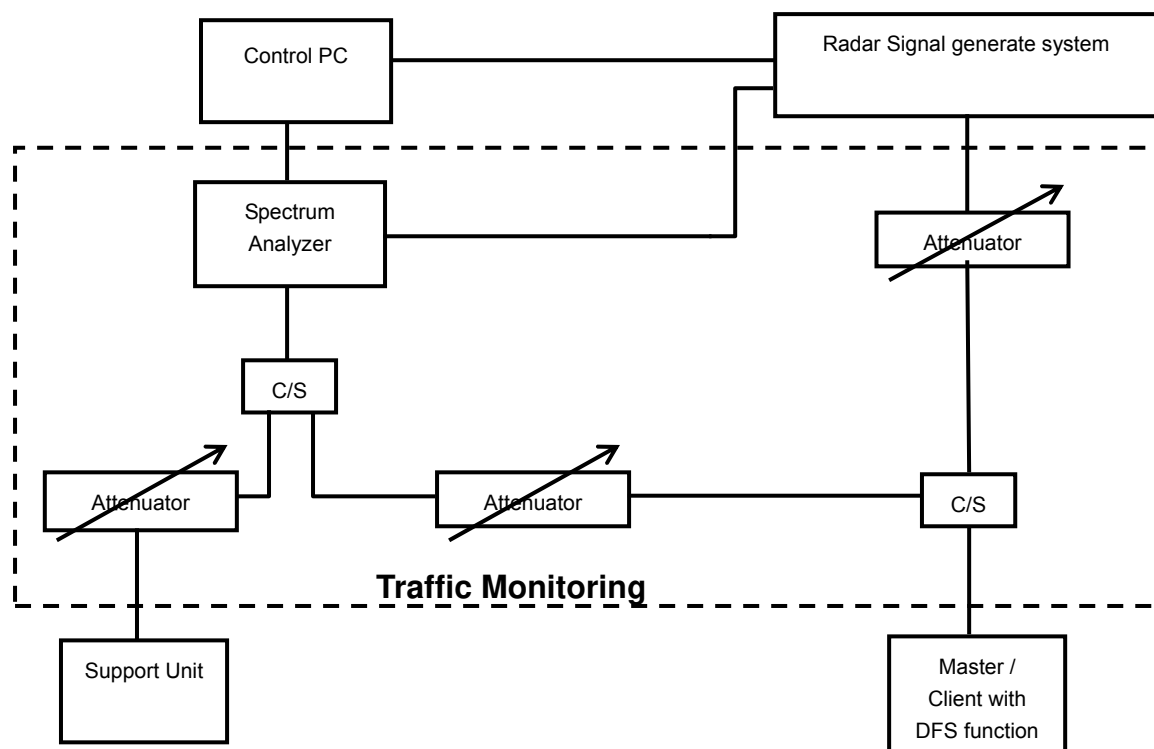

Channel Loading

System testing will be performed with channel-loading using means appropriate to the data types that are used by the unlicensed device. The following requirements apply:

a)	The data file must be of a type that is typical for the device (i.e., MPEG-2, MPEG-4, WAV, MP3, MP4, AVI, etc.) and must generally be transmitting in a streaming mode.	
b)	Software to ping the client is permitted to simulate data transfer but must have random ping intervals.	
c)	Timing plots are required with calculations demonstrating a minimum channel loading of approximately 17% or greater.	✓
d)	Unicast or Multicast protocols are preferable but other protocols may be used. The appropriate protocol used must be described in the test procedures.	

5.2 CALIBRATION OF DFS DETECTION THRESHOLD LEVEL:

The measured channel is 5500MHz in 20MHz and 5510MHz in 40MHz and 5530 in 80MHz. The radar signal was the same as transmitted channels, and injected into the antenna port of AP (master) or Client Device with Radar Detection, measured the channel closing transmission time and channel move time.

5.2.1 MASTER MODE

The Master antenna net gain is 3.2dBi and required detection threshold is -59.8dBm (= -64 + 3.2 + 1)dBm.

The calibrated conducted detection threshold level is set to -59.8dBm.

Conducted setup configuration of Calibration of DFS Detection Threshold Level

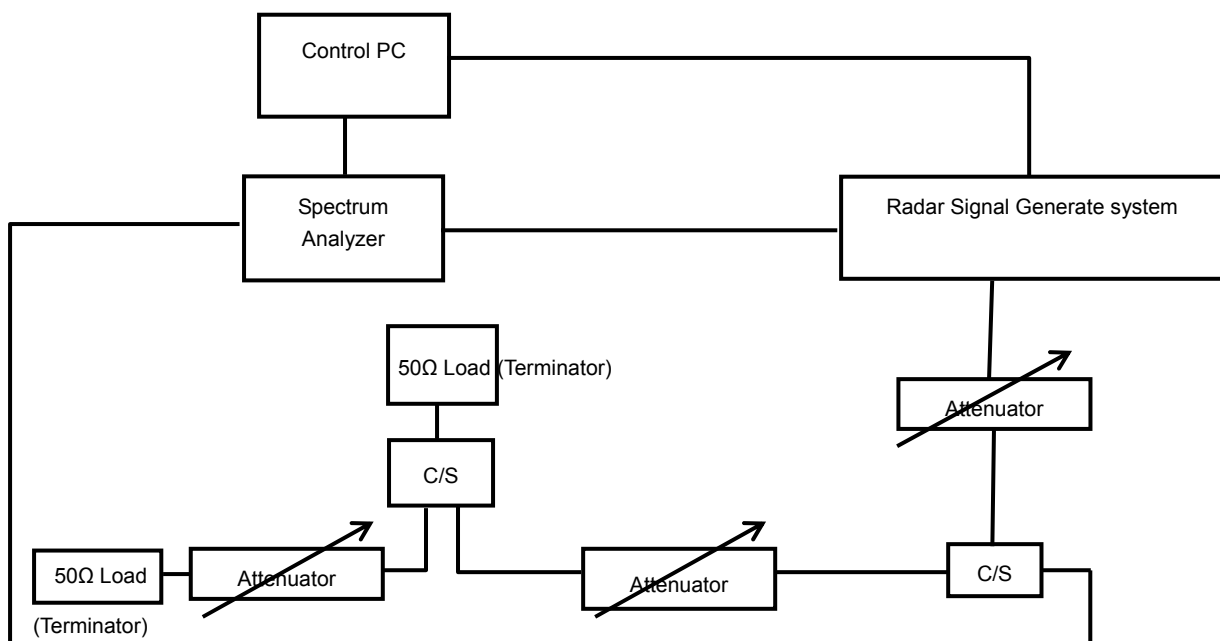

5.3 DEVIATION FROM TEST STANDARD

No deviation.

5.4 CONDUCTED TEST SETUP CONFIGURATION

MASTER MODE

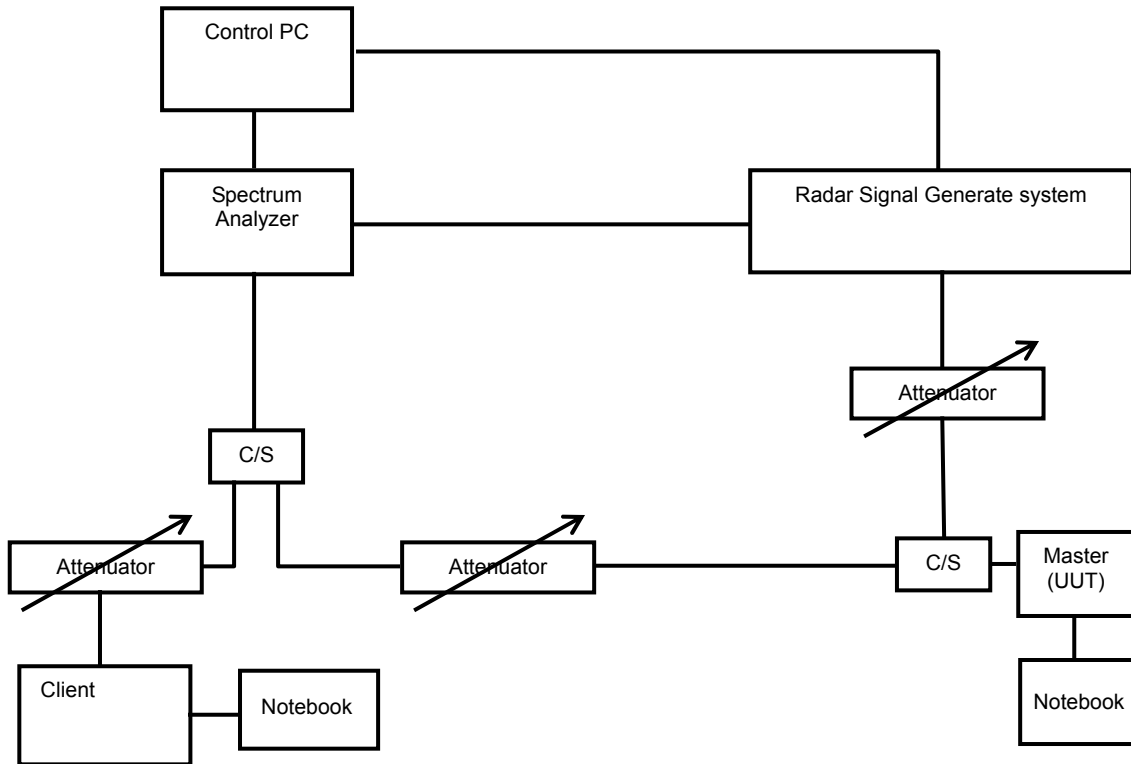

The UUT is a U-NII Device operating in Master mode. The radar test signals are injected into the Master Device.



6. TEST RESULTS

6.1 SUMMARY OF TEST RESULT

MASTER MODE

Clause	Test Parameter	Remarks	Pass/Fail
15.407	DFS Detection Threshold	Applicable	Pass
15.407	Channel Availability Check Time	Applicable	Pass
15.407	Channel Move Time	Applicable	Pass
15.407	Channel Closing Transmission Time	Applicable	Pass
15.407	Non- Occupancy Period	Applicable	Pass
15.407	U-NII Detection Bandwidth	Applicable	Pass
15.407	Non-Co-Channel test	Applicable	Pass

6.2 DETAILED TEST RESULTS

6.2.1. TEST MODE: DEVICE OPERATING IN MASTER MODE.

The radar test signals are injected into the Master Device.

6.2.1.1 DFS DETECTION THRESHOLD

The required detection threshold is -59.8dBm ($= -64 + 3.2 + 1$) dBm. The conducted radar burst level is lower than -59.8dBm .

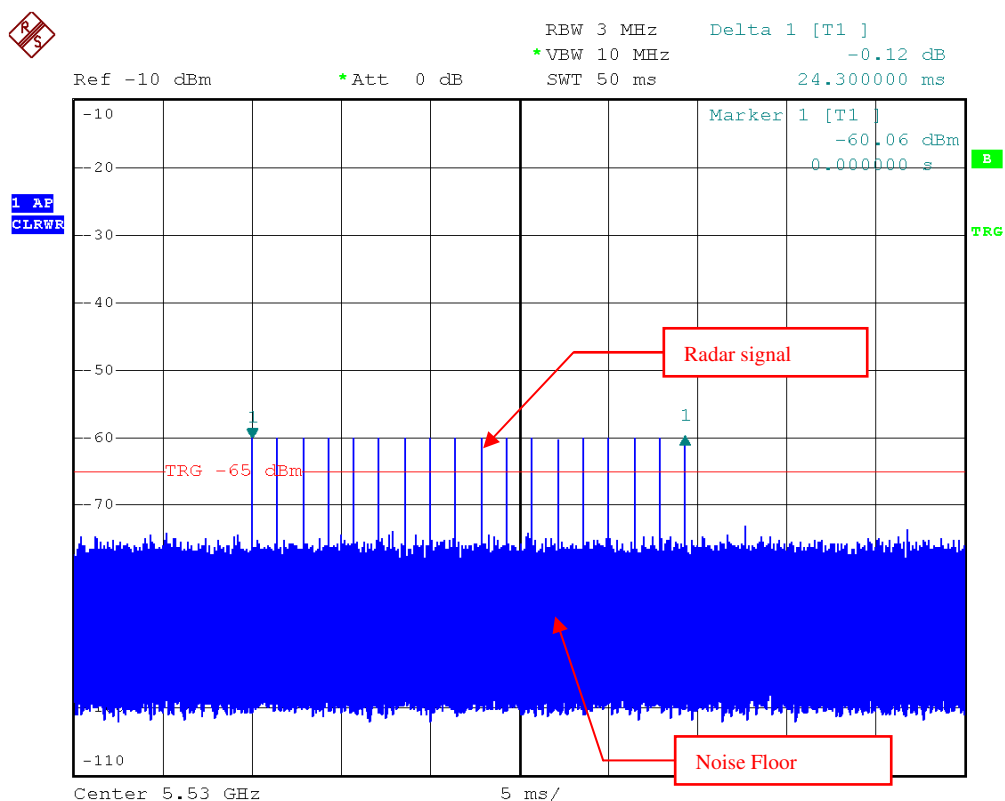

Radar Signal 0



A D T

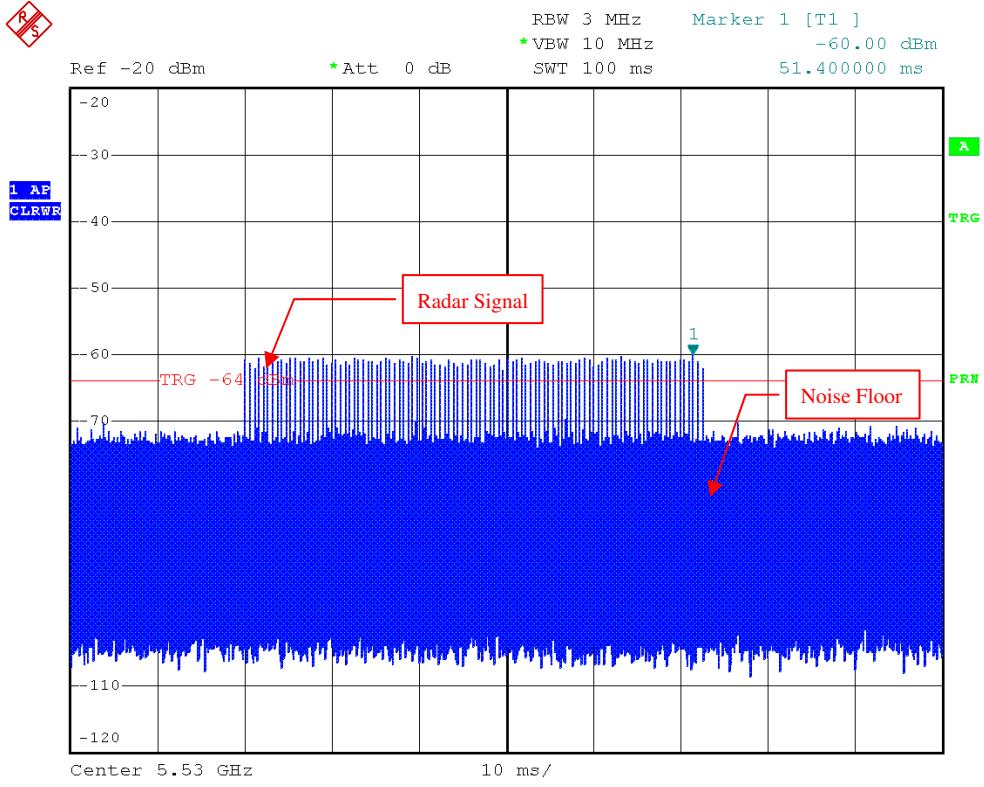

Radar Signal 1 (Test A)



A D T

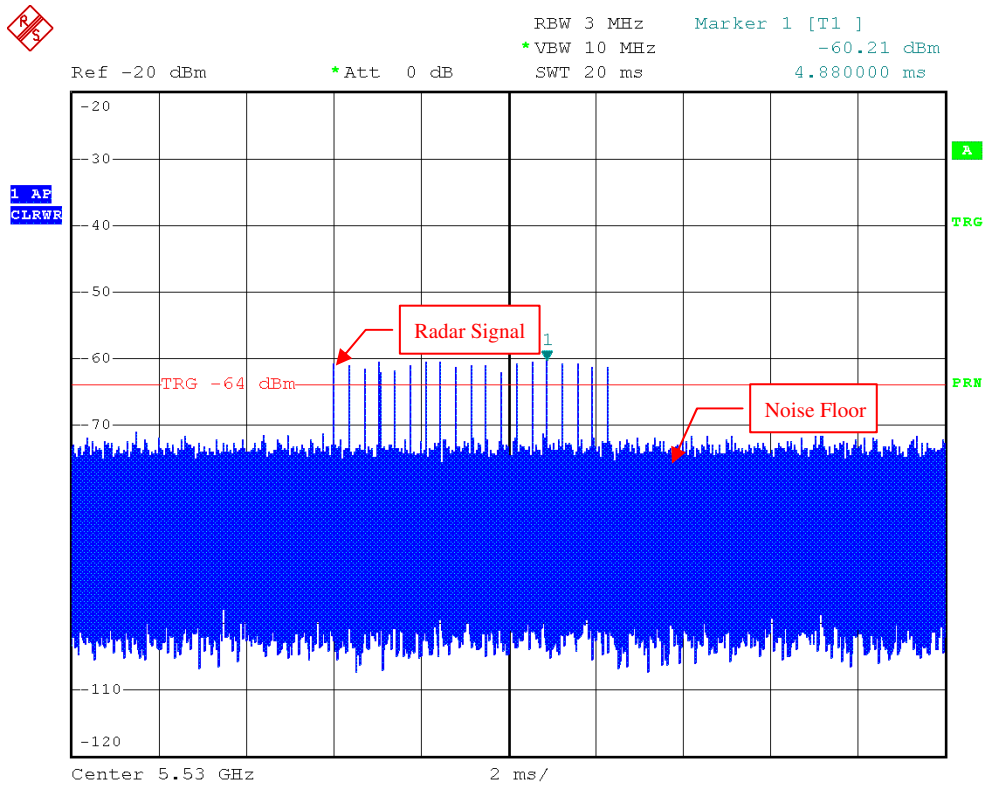

Radar Signal 1 (Test B)



A D T

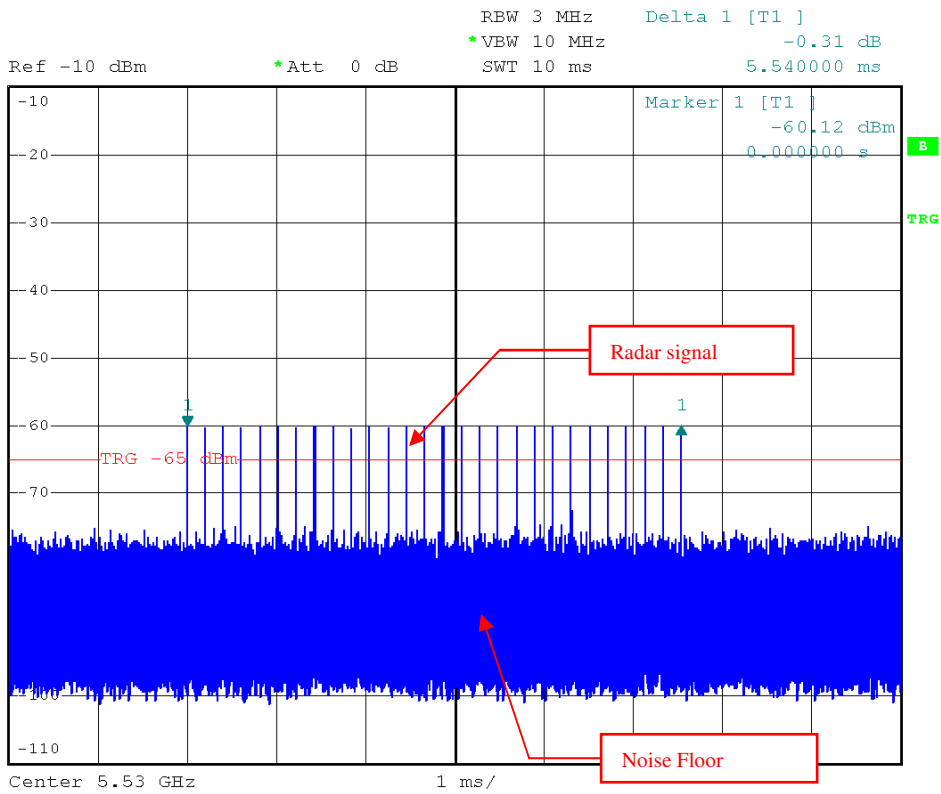

Radar Signal 2



A D T

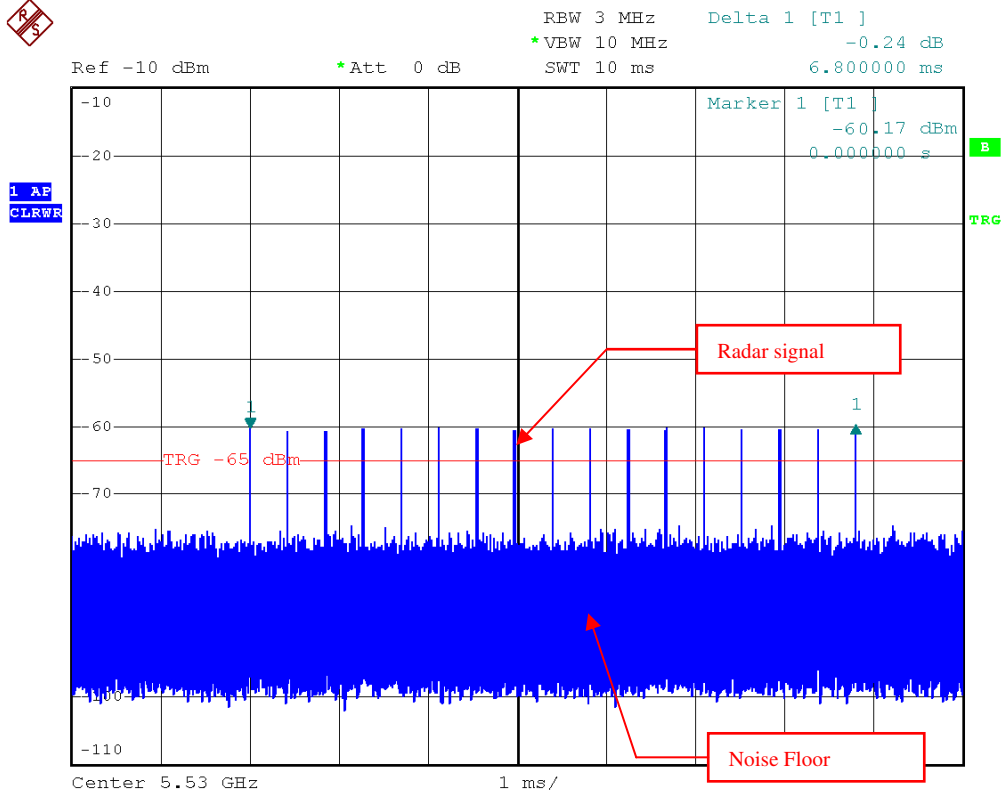

Radar Signal 3



A D T

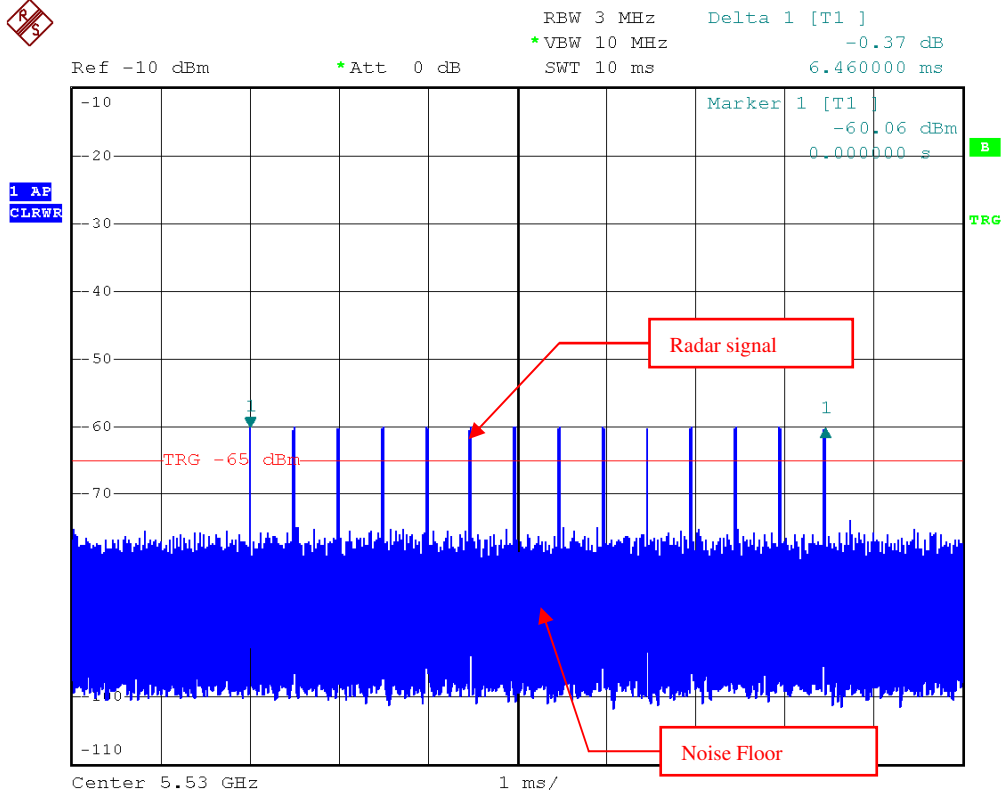

Radar Signal 4



A D T

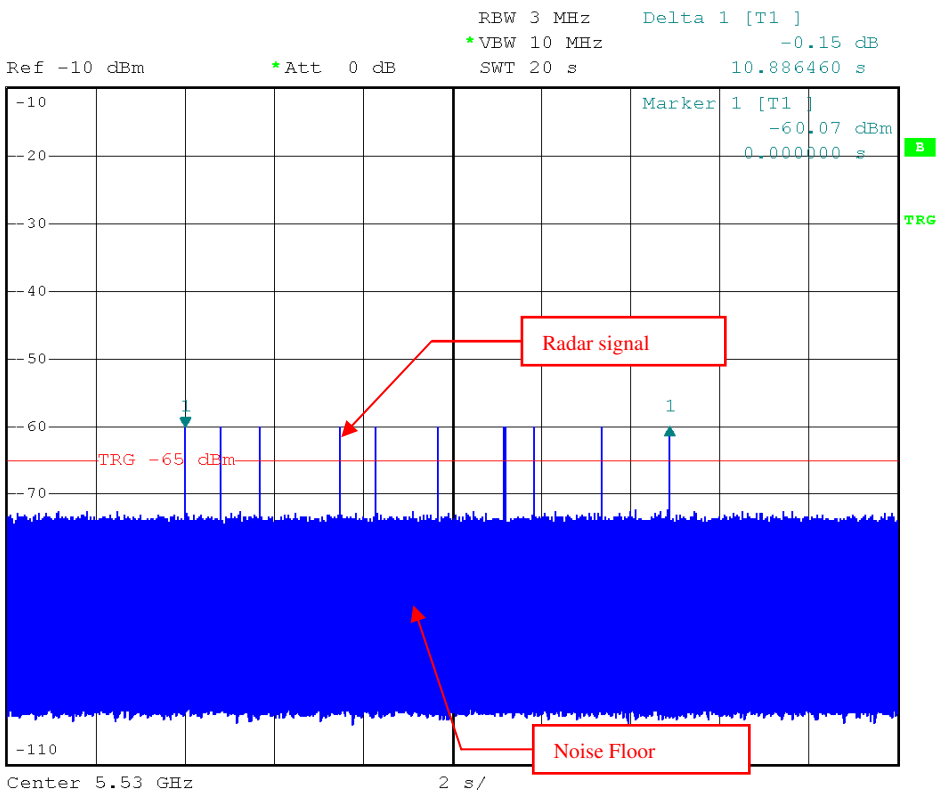

Radar Signal 5



A D T

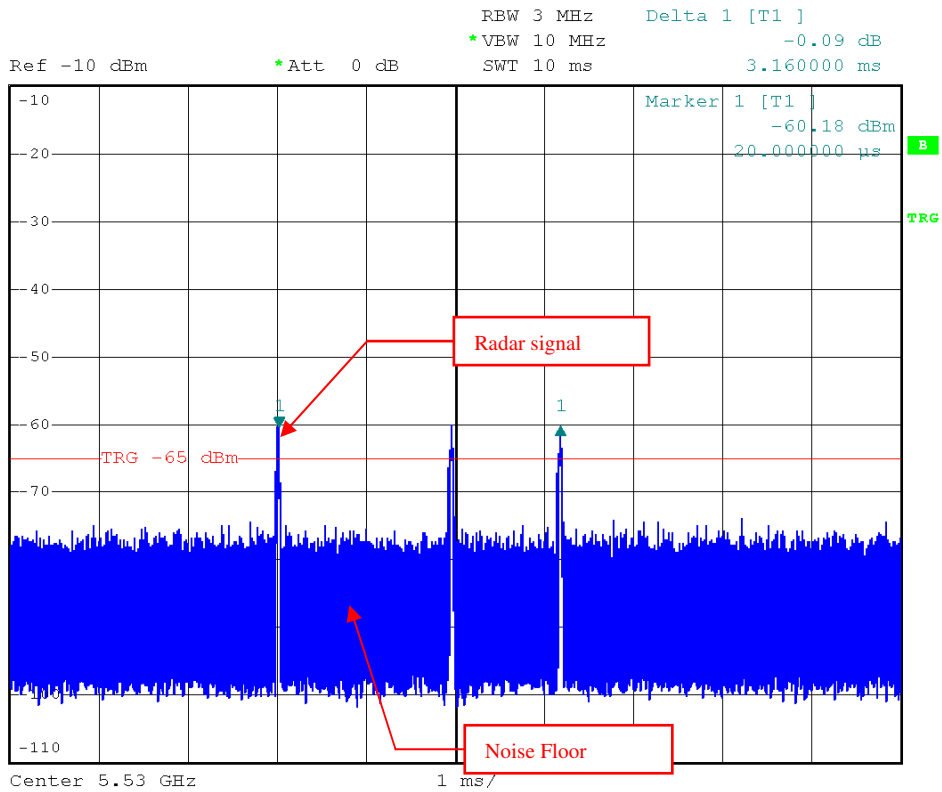

Single Burst of Radar Signal 5



A D T

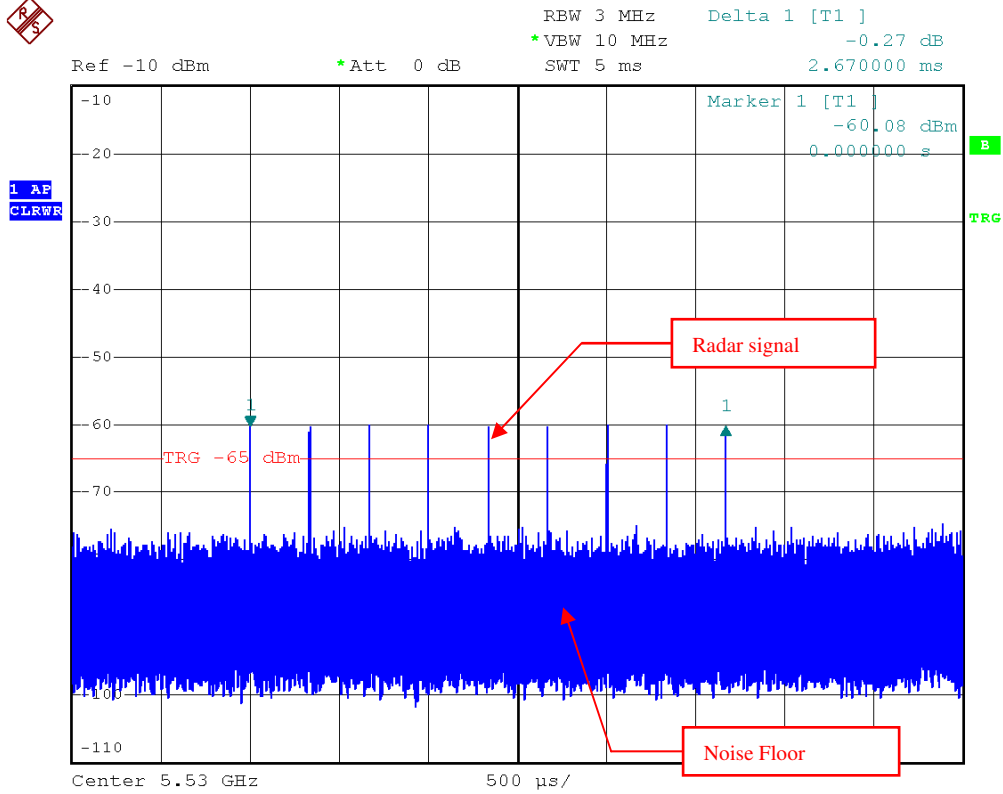

Radar Signal 6

6.2.1.2 CHANNEL AVAILABILITY CHECK TIME

If the EUT successfully detected the radar burst, it should be observed as the EUT has no transmissions occurred until the EUT starts transmitting on another channel.

Timing of Radar Signal	Observation	
	EUT	Spectrum Analyzer
Within 1 to 6 second	Detected	No transmissions
Within 54 to 60 second	Detected	No transmissions

Initial Channel Availability Check Time

Channel Availability Check

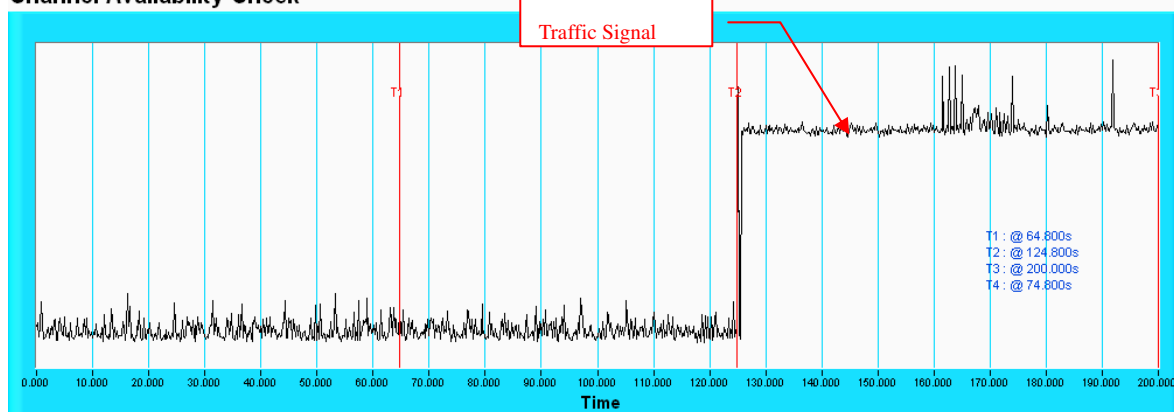

NOTE: T1 denotes the end of power-up time period is 64.8th second. T2 denotes the end of Channel Availability Check time is 124.8th second. Channel Availability Check time is equal to (T2 – T1) 60 seconds.

Radar Burst at the Beginning of the Channel Availability Check Time

Channel Availability Check

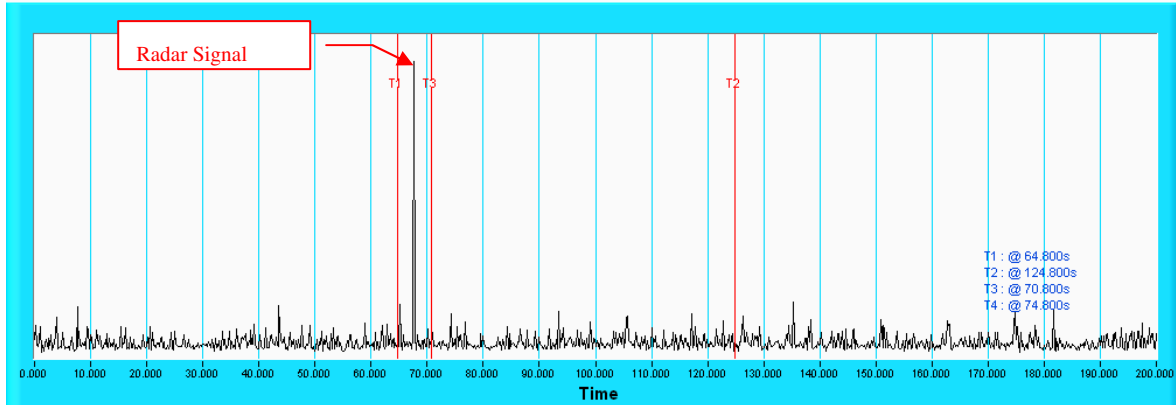

NOTE: T1 denotes the end of power up time period is 64.8th second. T3 denotes 70.8th second and the radar burst was commenced within a 6 second window starting from the end of power-up sequence. T2 denotes the 124.8th second.

Radar Burst at the End of the Channel Availability Check Time

Channel Availability Check

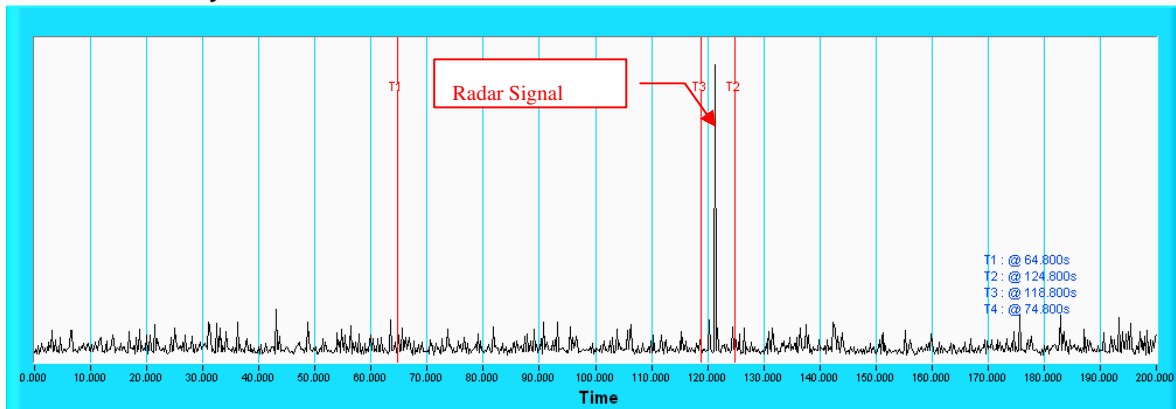

NOTE: T1 denotes the end of power up time period is 64.8th second. T3 denotes 118.8th second and the radar burst was commenced within 54th second to 60th second window starting from the end of power-up sequence. T2 denotes the 124.8th second.



6.2.1.3 CHANNEL CLOSING TRANSMISSION AND CHANNEL MOVE TIME

802.11ac (VHT20)

Short Pulse Radar Test Waveforms

Radar Type	Pulse Width (μsec)	PRI (μsec)	Number of Pulses	Number of Trials(Time s)	Percentage of Successful Detection (%)
1	<p>Test A: 15 unique PRI values randomly selected from the list of 23 PRI values in Table 5a</p> <p>-----</p> <p>Test B: 15 unique PRI values randomly selected within the range of 518-3066 μ sec, with a minimum increment of 1 μ sec, excluding PRI values selected in Test A</p>	$\text{Roundup} \left\{ \begin{array}{l} \left(\frac{1}{360} \right) \\ \left(\frac{19 \cdot 10^6}{\text{PRI}_{\mu\text{sec}}} \right) \end{array} \right\}$	18	30	96.7%
2	1-5	150-230	23-29	30	96.7%
3	6-10	200-500	16-18	30	76.7%
4	11-20	200-500	12-16	30	93.3%
Aggregate (Radar Types 1-4)				120	90.83%



A D T

Long Pulse Radar Test Waveform

Radar Type	Pulse Width (μsec)	Chirp Width (MHz)	PRI (μsec)	Number of Pulses per Burst	Number of Bursts	Number of Trials(Times)	Percentage of Successful Detection (%)
5	50-100	5-20	1000-2000	1-3	8-20	30	93.3%

Frequency Hopping Radar Test Waveform

Radar Type	Pulse Width (μsec)	PRI (μsec)	Pulses per Hop	Hopping Rate (kHz)	Hopping Sequence Length (msec)	Number of Trials(Times)	Percentage of Successful Detection (%)
6	1	333	9	0.333	300	30	100.0%



A D T

802.11ac (VHT40)

Short Pulse Radar Test Waveforms

Radar Type	Pulse Width (μsec)	PRI (μsec)	Number of Pulses	Number of Trials(Time s)	Percentage of Successful Detection (%)
1	<p>Test A: 15 unique PRI values randomly selected from the list of 23 PRI values in Table 5a</p> <p>-----</p> <p>Test B: 15 unique PRI values randomly selected within the range of 518-3066 μ sec, with a minimum increment of 1 μ sec, excluding PRI values selected in Test A</p>	$\text{Roundup} \left\{ \left(\frac{1}{360} \right) \cdot \left(\frac{19 \cdot 10^6}{\text{PRI}_{\mu\text{sec}}} \right) \right\}$	18	30	100%
2	1-5	150-230	23-29	30	93.3%
3	6-10	200-500	16-18	30	93.3%
4	11-20	200-500	12-16	30	86.7%
Aggregate (Radar Types 1-4)				120	93.33%



A D T

Long Pulse Radar Test Waveform

Radar Type	Pulse Width (μsec)	Chirp Width (MHz)	PRI (μsec)	Number of Pulses per Burst	Number of Bursts	Number of Trials(Times)	Percentage of Successful Detection (%)
5	50-100	5-20	1000-2000	1-3	8-20	30	90.0%

Frequency Hopping Radar Test Waveform

Radar Type	Pulse Width (μsec)	PRI (μsec)	Pulses per Hop	Hopping Rate (kHz)	Hopping Sequence Length (msec)	Number of Trials(Times)	Percentage of Successful Detection (%)
6	1	333	9	0.333	300	30	100.0%



A D T

802.11ac (VHT80)

Short Pulse Radar Test Waveforms

Radar Type	Pulse Width (μsec)	PRI (μsec)	Number of Pulses	Number of Trials(Times)	Percentage of Successful Detection (%)
1	<p>Test A: 15 unique PRI values randomly selected from the list of 23 PRI values in Table 5a</p> <p>-----</p> <p>Test B: 15 unique PRI values randomly selected within the range of 518-3066 μ sec, with a minimum increment of 1 μ sec, excluding PRI values selected in Test A</p>	$\text{Roundup} \left\{ \left(\frac{1}{360} \right) \cdot \left(\frac{19 \cdot 10^6}{\text{PRI}_{\mu\text{sec}}} \right) \right\}$	18	30	100%
2	1-5	150-230	23-29	30	93.3%
3	6-10	200-500	16-18	30	80.0%
4	11-20	200-500	12-16	30	80.0%
Aggregate (Radar Types 1-4)				120	88.33%



A D T

Long Pulse Radar Test Waveform

Radar Type	Pulse Width (μsec)	Chirp Width (MHz)	PRI (μsec)	Number of Pulses per Burst	Number of Bursts	Number of Trials(Times)	Percentage of Successful Detection (%)
5	50-100	5-20	1000-2000	1-3	8-20	30	90.0%

Frequency Hopping Radar Test Waveform

Radar Type	Pulse Width (μsec)	PRI (μsec)	Pulses per Hop	Hopping Rate (kHz)	Hopping Sequence Length (msec)	Number of Trials(Times)	Percentage of Successful Detection (%)
6	1	333	9	0.333	300	30	100.0%



Wireless Traffic Loading

802.11ac (VHT20)

Duty cycle @ CH100 - 5500MHz

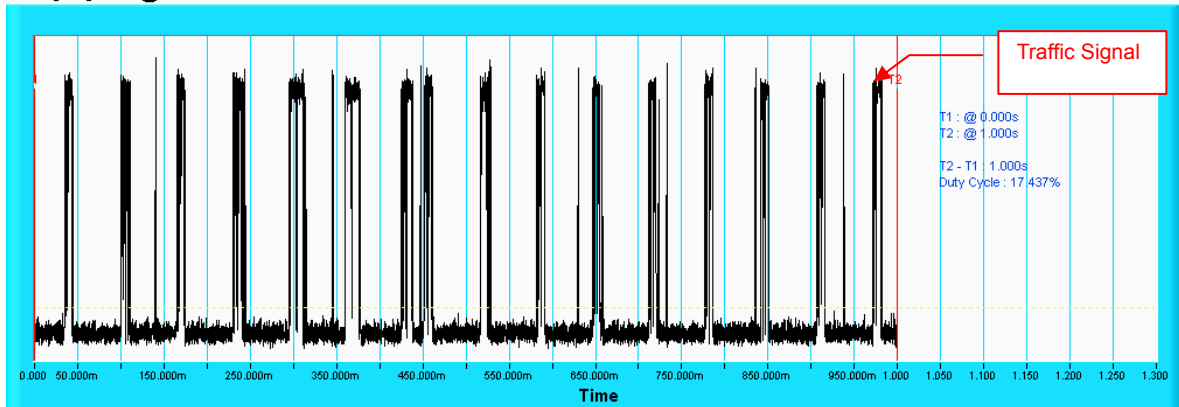

NOTE: T1 denotes the start of duty cycle period is 0th second. T2 denotes the end of duty cycle period is 1th second. T2 – T1= 1 seconds. Duty Cycle = 17.437%

802.11ac (VHT40)

Duty cycle @ CH102 - 5510MHz

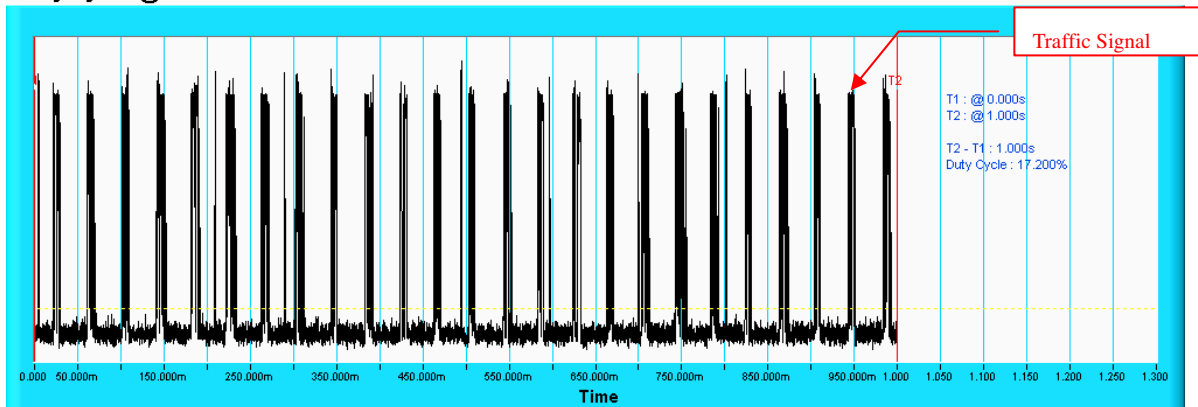

NOTE: T1 denotes the start of duty cycle period is 0th second. T2 denotes the end of duty cycle period is 1th second. T2 – T1= 1 seconds. Duty Cycle = 17.2%



A D T

802.11ac (VHT80)

Duty cycle @ CH106 - 5530MHz

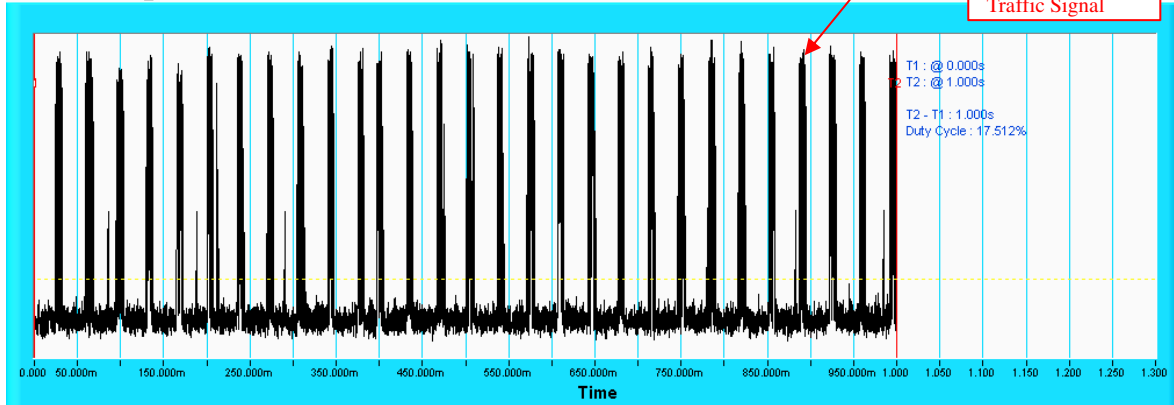

NOTE: T1 denotes the start of duty cycle period is 0th second. T2 denotes the end of duty cycle period is 1th second. T2 – T1= 1 seconds. Duty Cycle = 17.512%

Radar signal 1

Channel Closing Transmission Time & Channel Move Time

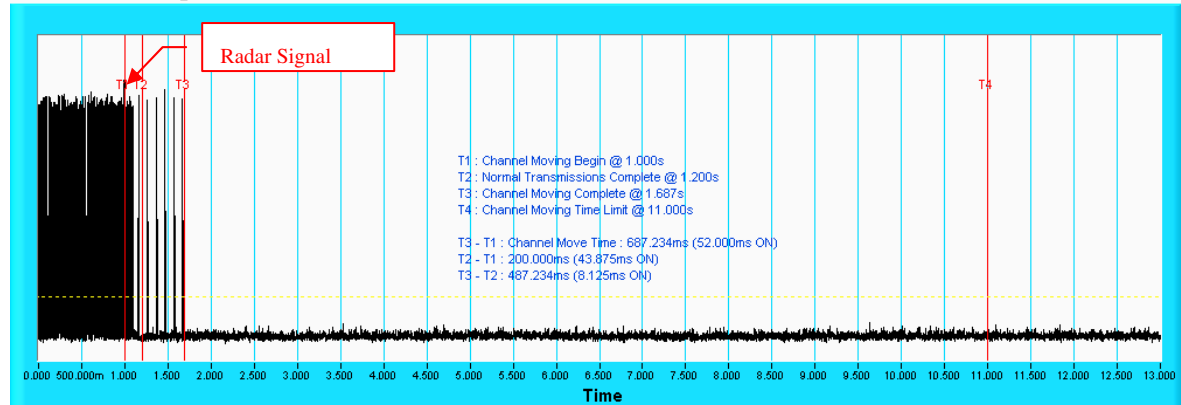

NOTE: T1 denotes the start of Channel Move Time upon the end of the last Radar burst. T2 denotes the data transmission time of 200ms from T1. T3 denotes the end of Channel Move Time. T4 denotes the 10 second from T1 to observe the aggregate duration of transmissions.

Channel Closing Transmission Time & Channel Move Time

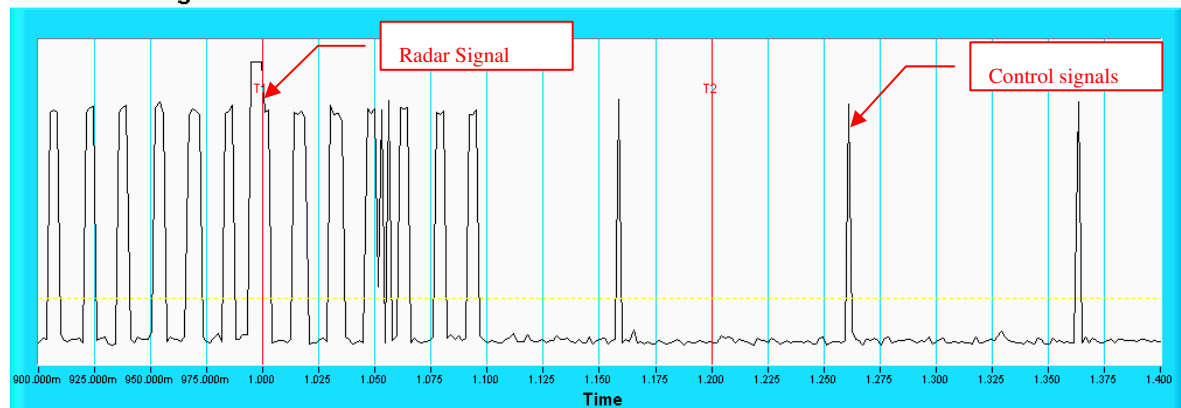

NOTE: An expanded plot for the device vacates the channel in the required 500ms.

Radar signal 2

Channel Closing Transmission Time & Channel Move Time

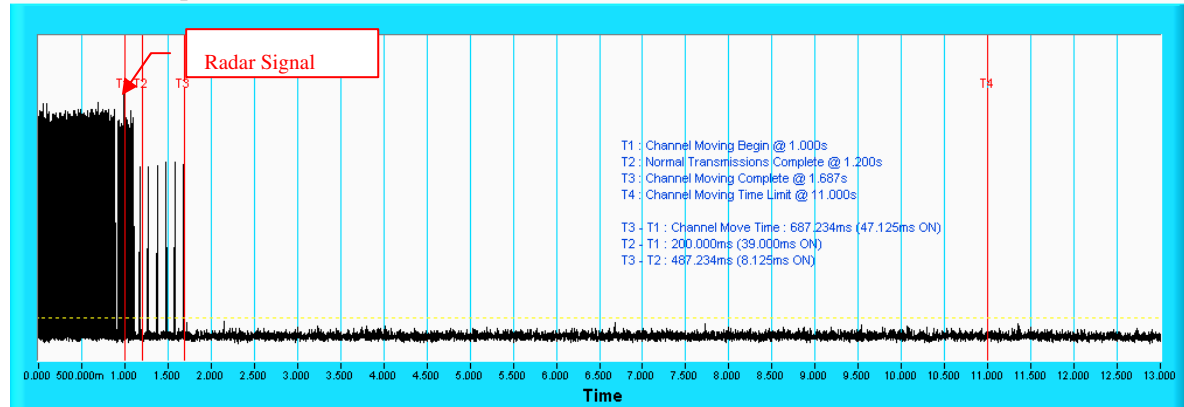

NOTE: T1 denotes the start of Channel Move Time upon the end of the last Radar burst. T2 denotes the data transmission time of 200ms from T1. T3 denotes the end of Channel Move Time. T4 denotes the 10 second from T1 to observe the aggregate duration of transmissions.

Channel Closing Transmission Time & Channel Move Time

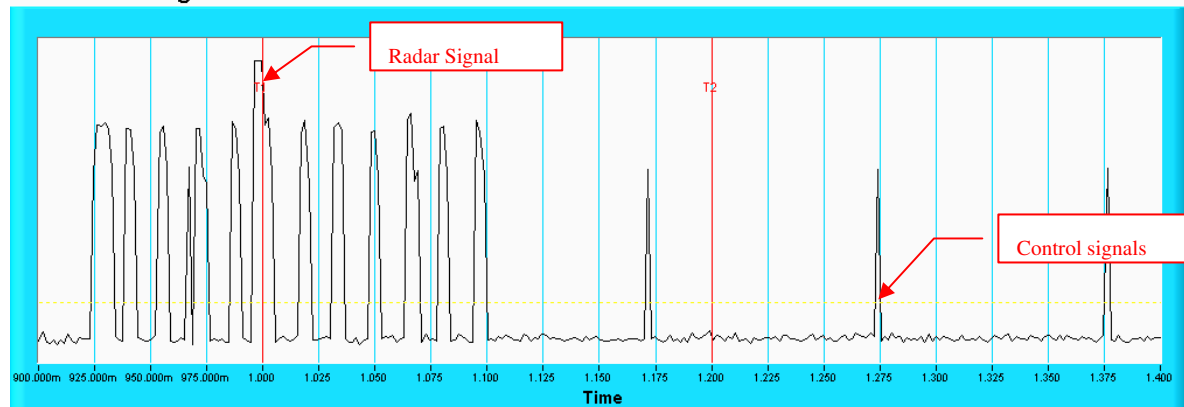

NOTE: An expanded plot for the device vacates the channel in the required 500ms.

Radar signal 3

Channel Closing Transmission Time & Channel Move Time

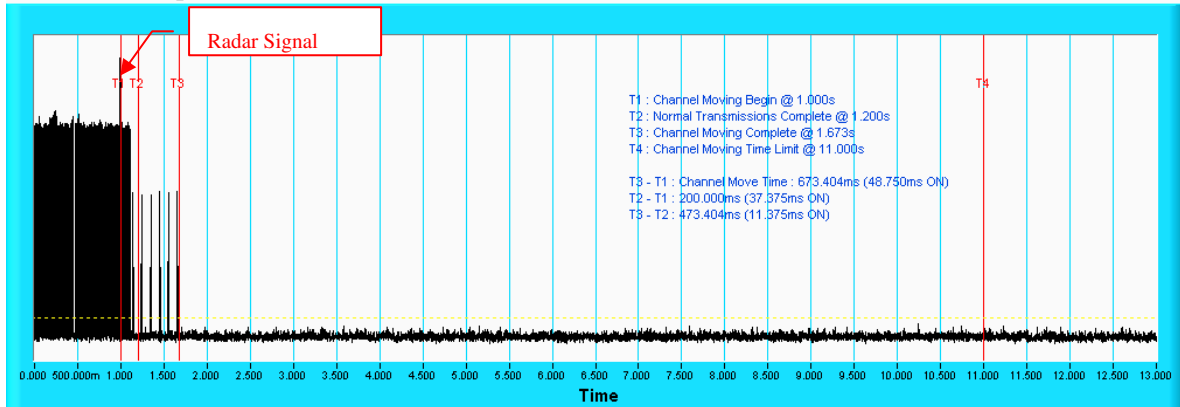

NOTE: T1 denotes the start of Channel Move Time upon the end of the last Radar burst. T2 denotes the data transmission time of 200ms from T1. T3 denotes the end of Channel Move Time. T4 denotes the 10 second from T1 to observe the aggregate duration of transmissions.

Channel Closing Transmission Time & Channel Move Time

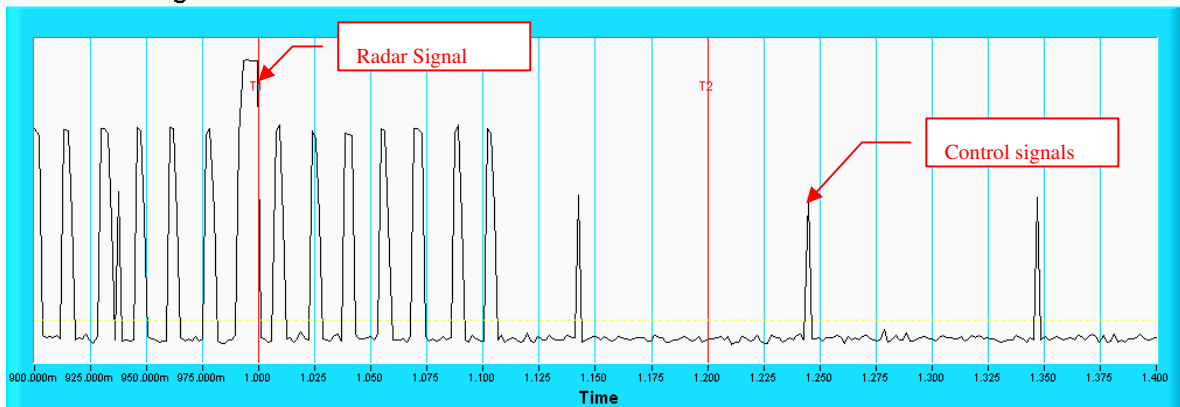

NOTE: An expanded plot for the device vacates the channel in the required 500ms.

Radar signal 4

Channel Closing Transmission Time & Channel Move Time

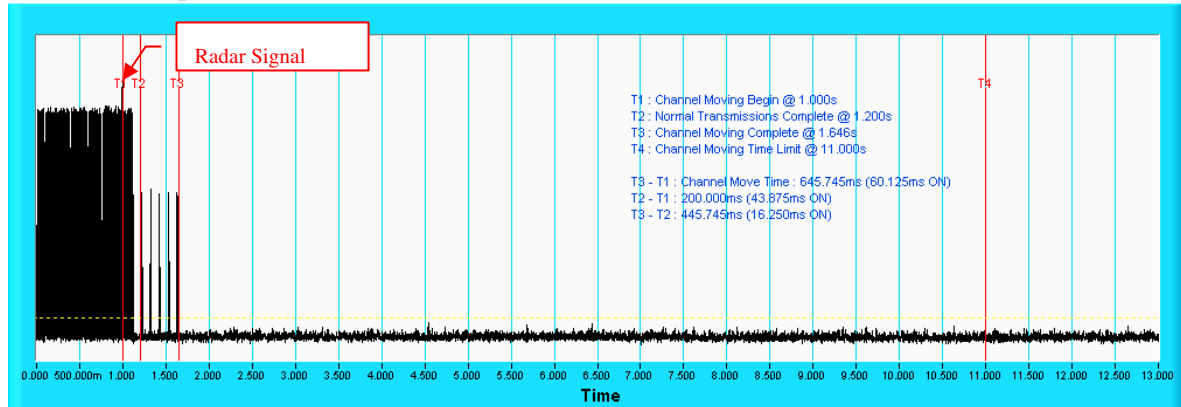

NOTE: T1 denotes the start of Channel Move Time upon the end of the last Radar burst. T2 denotes the data transmission time of 200ms from T1. T3 denotes the end of Channel Move Time. T4 denotes the 10 second from T1 to observe the aggregate duration of transmissions.

Channel Closing Transmission Time & Channel Move Time

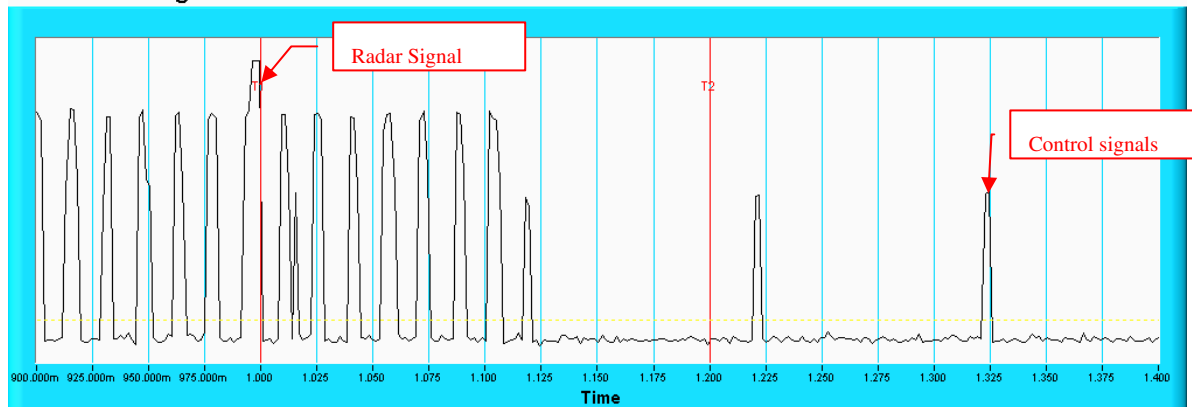

NOTE: An expanded plot for the device vacates the channel in the required 500ms.

Radar signal 5

Channel Closing Transmission Time & Channel Move Time

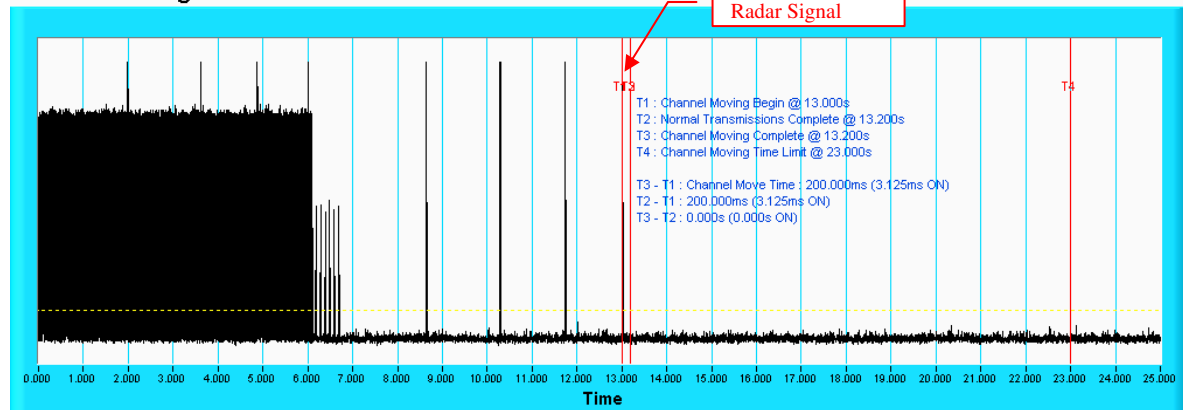

NOTE: T1 denotes the start of Channel Move Time upon the end of the last Radar burst. T2 denotes the data transmission time of 200ms from T1. T3 denotes the end of Channel Move Time. T4 denotes the 10 second from T1 to observe the aggregate duration of transmissions.

Channel Closing Transmission Time & Channel Move Time

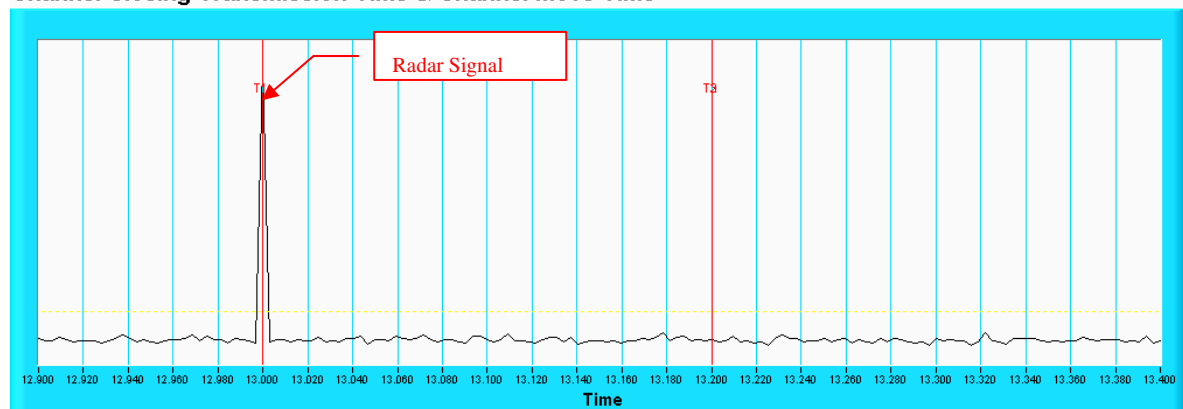

NOTE: An expanded plot for the device vacates the channel in the required 500ms.

Radar signal 6

Channel Closing Transmission Time & Channel Move Time

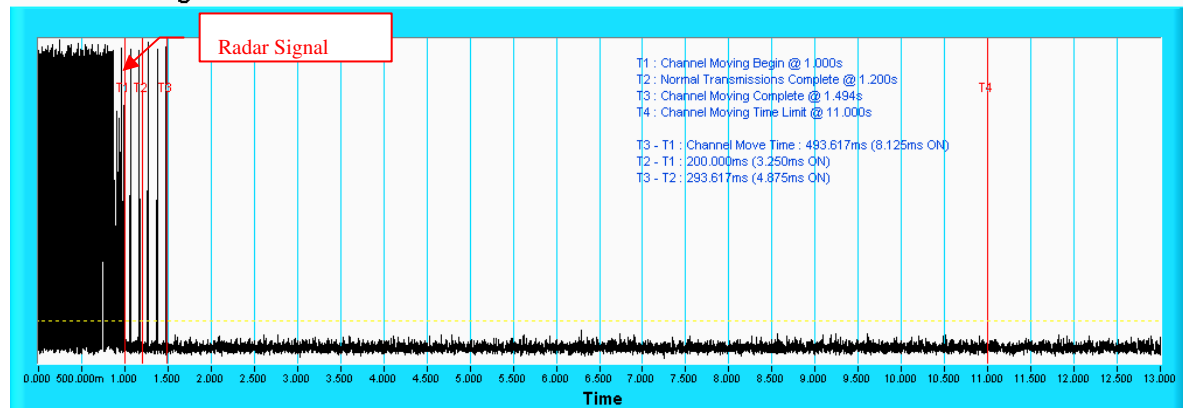

NOTE: T1 denotes the start of Channel Move Time upon the end of the last Radar burst. T2 denotes the data transmission time of 200ms from T1. T3 denotes the end of Channel Move Time. T4 denotes the 10 second from T1 to observe the aggregate duration of transmissions.

Channel Closing Transmission Time & Channel Move Time

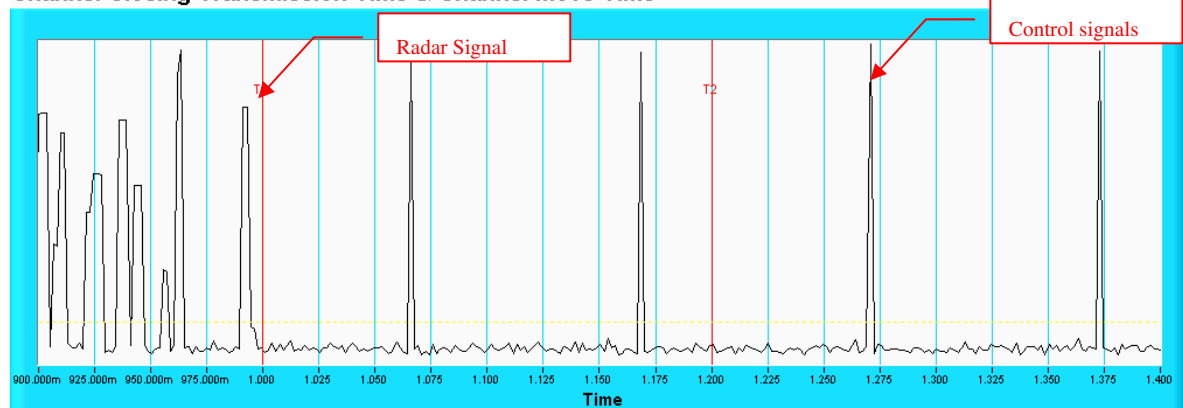

NOTE: An expanded plot for the device vacates the channel in the required 500ms.



A D T

802.11ac (VHT20)

Type 1 Radar Statistical Performances

Trial #	Test Frequency (MHz)	Pulse Repetition Frequency (Pulse per seconds)	Pulses per Burst	Pulse Repetition Interval (microseconds)	Detection
1	5500	1139	61	878	Yes
2	5506	1567.4	83	638	Yes
3	5508	1792.1	95	558	Yes
4	5503	1165.6	62	858	Yes
5	5498	1253.1	67	798	Yes
6	5504	1519.8	81	658	Yes
7	5492	1432.7	76	698	Yes
8	5508	1730.1	92	578	Yes
9	5505	1618.1	86	618	Yes
10	5501	1319.3	70	758	Yes
11	5506	1858.7	99	538	Yes
12	5505	1222.5	65	818	Yes
13	5500	1193.3	63	838	Yes
14	5495	326.2	18	3066	Yes
15	5497	1355	72	738	Yes
16	5494	545.3	29	1834	Yes
17	5494	445	24	2247	Yes
18	5501	522.7	28	1913	Yes
19	5504	441.9	24	2263	Yes
20	5508	1455.6	77	687	Yes
21	5493	397.1	21	2518	Yes
22	5498	362.8	20	2756	Yes
23	5502	1572.3	83	636	No
24	5498	564	30	1773	Yes
25	5498	335.6	18	2980	Yes
26	5509	390.5	21	2561	Yes
27	5495	459.3	25	2177	Yes
28	5506	371.6	20	2691	Yes
29	5507	457.5	25	2186	Yes
30	5494	563.1	30	1776	Yes

Detection Rate: 96.7 %



A D T

802.11ac (VHT20)

Type 2 Radar Statistical Performances				
Trial #	Test Frequency (MHz)	Pulse Width(us)	PRI(us)	Detection
1	5500	2.4	154	Yes
2	5498	3.1	173	Yes
3	5503	2.3	185	Yes
4	5500	3.9	229	Yes
5	5495	3.6	190	Yes
6	5505	2.8	176	Yes
7	5497	3.3	188	Yes
8	5493	3.8	224	Yes
9	5494	4.2	187	Yes
10	5493	3.1	157	Yes
11	5508	2.8	212	Yes
12	5495	4.6	212	Yes
13	5503	3.7	224	Yes
14	5503	3	194	Yes
15	5506	1	175	Yes
16	5497	1.4	193	Yes
17	5508	4.8	186	Yes
18	5508	3.8	199	No
19	5491	1.8	162	Yes
20	5499	1.2	203	Yes
21	5493	4.4	159	Yes
22	5503	1.1	189	Yes
23	5497	2.3	215	Yes
24	5501	3.1	214	Yes
25	5504	3.4	197	Yes
26	5499	3.4	186	Yes
27	5499	2.9	205	Yes
28	5508	3.4	216	Yes
29	5493	4	221	Yes
30	5496	2.5	220	Yes
				Detection Rate: 96.7 %



A D T

802.11ac (VHT20)

Type 3 Radar Statistical Performances

Trial #	Test Frequency (MHz)	Pulse Width(us)	PRI(us)	Detection
1	5500	6.3	407	Yes
2	5500	8.1	457	Yes
3	5505	7	351	Yes
4	5506	7.2	238	Yes
5	5496	9	256	No
6	5498	6.6	466	Yes
7	5495	7.2	454	Yes
8	5494	6.2	215	Yes
9	5500	9.8	221	No
10	5496	6.8	291	Yes
11	5507	6.2	214	Yes
12	5507	6.3	486	No
13	5496	8.9	374	No
14	5492	8.6	304	Yes
15	5499	8.3	400	No
16	5499	7.1	291	Yes
17	5493	6.9	259	Yes
18	5493	9.9	497	Yes
19	5492	6.2	323	Yes
20	5499	9	311	Yes
21	5501	6.9	428	No
22	5507	9.9	226	Yes
23	5508	6.9	443	Yes
24	5507	6.3	493	Yes
25	5506	8.9	452	Yes
26	5498	7.9	464	Yes
27	5502	6.9	272	Yes
28	5501	7.2	317	Yes
29	5505	9.9	223	No
30	5501	7.3	477	Yes

Detection Rate: 76.7 %



A D T

802.11ac (VHT20)

Type 4 Radar Statistical Performances				
Trial #	Test Frequency (MHz)	Pulse Width(us)	PRI(us)	Detection
1	5500	20	239	Yes
2	5499	12	465	Yes
3	5497	14.9	270	Yes
4	5502	15.7	233	No
5	5498	14.5	441	Yes
6	5499	17.5	231	Yes
7	5506	18	306	Yes
8	5502	17.7	389	Yes
9	5495	14	214	Yes
10	5498	16.1	415	Yes
11	5495	19.4	495	Yes
12	5499	19.3	343	No
13	5498	15.6	349	Yes
14	5493	16.9	393	Yes
15	5502	17.4	250	Yes
16	5495	14.8	425	Yes
17	5495	20	372	Yes
18	5500	11.3	476	Yes
19	5505	17.7	425	Yes
20	5492	17.5	347	Yes
21	5491	16.8	483	Yes
22	5495	17.4	350	Yes
23	5497	19.1	476	Yes
24	5492	19.3	365	Yes
25	5496	13	260	Yes
26	5502	19	303	Yes
27	5507	18	311	Yes
28	5508	19.8	493	Yes
29	5498	13.5	333	Yes
30	5500	13.6	478	Yes
Detection Rate: 93.3 %				



802.11ac (VHT20)

Type 5 Radar Statistical Performances			
Trial #	Chirp Center Frequency(MHz)	Test Signal Name	Detection
1	5500	LP_Signal_01	Yes
2	5497	LP_Signal_02	Yes
3	5500	LP_Signal_03	Yes
4	5505	LP_Signal_04	Yes
5	5501	LP_Signal_05	Yes
6	5496	LP_Signal_06	Yes
7	5503	LP_Signal_07	No
8	5498	LP_Signal_08	Yes
9	5497	LP_Signal_09	Yes
10	5498	LP_Signal_10	Yes
11	5501	LP_Signal_11	Yes
12	5494	LP_Signal_12	Yes
13	5503	LP_Signal_13	Yes
14	5505	LP_Signal_14	Yes
15	5505	LP_Signal_15	Yes
16	5502	LP_Signal_16	Yes
17	5501	LP_Signal_17	Yes
18	5506	LP_Signal_18	Yes
19	5505	LP_Signal_19	No
20	5506	LP_Signal_20	Yes
21	5505	LP_Signal_21	Yes
22	5493	LP_Signal_22	Yes
23	5494	LP_Signal_23	Yes
24	5494	LP_Signal_24	Yes
25	5493	LP_Signal_25	Yes
26	5497	LP_Signal_26	Yes
27	5506	LP_Signal_27	Yes
28	5500	LP_Signal_28	Yes
29	5503	LP_Signal_29	Yes
30	5498	LP_Signal_30	Yes
			Detection Rate: 93.3 %

The Long Pulse Radar pattern shown in Appendix B.1



A D T

802.11ac (VHT20)

Type 6 Radar Statistical Performances				
Trial #	Pulses per Burst	Pulse Width(us)	PRI(us)	Detection
1	9	1	333.3	Yes
2	9	1	333.3	Yes
3	9	1	333.3	Yes
4	9	1	333.3	Yes
5	9	1	333.3	Yes
6	9	1	333.3	Yes
7	9	1	333.3	Yes
8	9	1	333.3	Yes
9	9	1	333.3	Yes
10	9	1	333.3	Yes
11	9	1	333.3	Yes
12	9	1	333.3	Yes
13	9	1	333.3	Yes
14	9	1	333.3	Yes
15	9	1	333.3	Yes
16	9	1	333.3	Yes
17	9	1	333.3	Yes
18	9	1	333.3	Yes
19	9	1	333.3	Yes
20	9	1	333.3	Yes
21	9	1	333.3	Yes
22	9	1	333.3	Yes
23	9	1	333.3	Yes
24	9	1	333.3	Yes
25	9	1	333.3	Yes
26	9	1	333.3	Yes
27	9	1	333.3	Yes
28	9	1	333.3	Yes
29	9	1	333.3	Yes
30	9	1	333.3	Yes
Detection Rate: 100 %				



A D T

802.11ac (VHT20)

Type 6 Radar Statistical Performances		
Trial #	Hopping Frequency Sequence Name	Detection
1	HOP_FREQ_SEQ_01	Yes
2	HOP_FREQ_SEQ_02	Yes
3	HOP_FREQ_SEQ_03	Yes
4	HOP_FREQ_SEQ_04	Yes
5	HOP_FREQ_SEQ_05	Yes
6	HOP_FREQ_SEQ_06	Yes
7	HOP_FREQ_SEQ_07	Yes
8	HOP_FREQ_SEQ_08	Yes
9	HOP_FREQ_SEQ_09	Yes
10	HOP_FREQ_SEQ_10	Yes
11	HOP_FREQ_SEQ_11	Yes
12	HOP_FREQ_SEQ_12	Yes
13	HOP_FREQ_SEQ_13	Yes
14	HOP_FREQ_SEQ_14	Yes
15	HOP_FREQ_SEQ_15	Yes
16	HOP_FREQ_SEQ_16	Yes
17	HOP_FREQ_SEQ_17	Yes
18	HOP_FREQ_SEQ_18	Yes
19	HOP_FREQ_SEQ_19	Yes
20	HOP_FREQ_SEQ_20	Yes
21	HOP_FREQ_SEQ_21	Yes
22	HOP_FREQ_SEQ_22	Yes
23	HOP_FREQ_SEQ_23	Yes
24	HOP_FREQ_SEQ_24	Yes
25	HOP_FREQ_SEQ_25	Yes
26	HOP_FREQ_SEQ_26	Yes
27	HOP_FREQ_SEQ_27	Yes
28	HOP_FREQ_SEQ_28	Yes
29	HOP_FREQ_SEQ_29	Yes
30	HOP_FREQ_SEQ_30	Yes
		Detection Rate: 100 %

The Frequency Hopping Radar pattern shown in Appendix B.2



A D T

802.11ac (VHT40)

Type 1 Radar Statistical Performances

Trial #	Test Frequency (MHz)	Pulse Repetition Frequency (Pulse per seconds)	Pulses per Burst	Pulse Repetition Interval (microseconds)	Detection
1	5510	1139	61	878	Yes
2	5520	1567.4	83	638	Yes
3	5500	1792.1	95	558	Yes
4	5521	1165.6	62	858	Yes
5	5521	1253.1	67	798	Yes
6	5495	1519.8	81	658	Yes
7	5511	1432.7	76	698	Yes
8	5511	1730.1	92	578	Yes
9	5501	1618.1	86	618	Yes
10	5502	1319.3	70	758	Yes
11	5510	1858.7	99	538	Yes
12	5505	1222.5	65	818	Yes
13	5520	1193.3	63	838	Yes
14	5502	326.2	18	3066	Yes
15	5499	1355	72	738	Yes
16	5514	545.3	29	1834	Yes
17	5509	445	24	2247	Yes
18	5507	522.7	28	1913	Yes
19	5527	441.9	24	2263	Yes
20	5496	1455.6	77	687	Yes
21	5516	397.1	21	2518	Yes
22	5521	362.8	20	2756	Yes
23	5492	1572.3	83	636	Yes
24	5521	564	30	1773	Yes
25	5521	335.6	18	2980	Yes
26	5527	390.5	21	2561	Yes
27	5498	459.3	25	2177	Yes
28	5525	371.6	20	2691	Yes
29	5515	457.5	25	2186	Yes
30	5512	563.1	30	1776	Yes

Detection Rate: 100 %



A D T

802.11ac (VHT40)

Type 2 Radar Statistical Performances				
Trial #	Test Frequency (MHz)	Pulse Width(us)	PRI(us)	Detection
1	5510	2.4	154	Yes
2	5520	3.1	173	Yes
3	5500	2.3	185	Yes
4	5492	3.9	229	Yes
5	5508	3.6	190	Yes
6	5498	2.8	176	Yes
7	5520	3.3	188	Yes
8	5519	3.8	224	Yes
9	5524	4.2	187	Yes
10	5504	3.1	157	Yes
11	5497	2.8	212	Yes
12	5497	4.6	212	Yes
13	5501	3.7	224	Yes
14	5507	3	194	Yes
15	5512	1	175	Yes
16	5499	1.4	193	No
17	5522	4.8	186	Yes
18	5513	3.8	199	Yes
19	5526	1.8	162	Yes
20	5504	1.2	203	No
21	5496	4.4	159	Yes
22	5501	1.1	189	Yes
23	5497	2.3	215	Yes
24	5527	3.1	214	Yes
25	5519	3.4	197	Yes
26	5524	3.4	186	Yes
27	5498	2.9	205	Yes
28	5526	3.4	216	Yes
29	5511	4	221	Yes
30	5498	2.5	220	Yes
				Detection Rate: 93.3 %



A D T

802.11ac (VHT40)

Type 3 Radar Statistical Performances				
Trial #	Test Frequency (MHz)	Pulse Width(us)	PRI(us)	Detection
1	5510	6.3	407	Yes
2	5520	8.1	457	Yes
3	5500	7	351	Yes
4	5503	7.2	238	Yes
5	5505	9	256	Yes
6	5493	6.6	466	Yes
7	5515	7.2	454	Yes
8	5513	6.2	215	Yes
9	5528	9.8	221	No
10	5499	6.8	291	No
11	5526	6.2	214	Yes
12	5507	6.3	486	Yes
13	5506	8.9	374	Yes
14	5510	8.6	304	Yes
15	5528	8.3	400	Yes
16	5514	7.1	291	Yes
17	5495	6.9	259	Yes
18	5496	9.9	497	Yes
19	5493	6.2	323	Yes
20	5511	9	311	Yes
21	5522	6.9	428	Yes
22	5506	9.9	226	Yes
23	5527	6.9	443	Yes
24	5507	6.3	493	Yes
25	5521	8.9	452	Yes
26	5502	7.9	464	Yes
27	5525	6.9	272	Yes
28	5496	7.2	317	Yes
29	5513	9.9	223	Yes
30	5518	7.3	477	Yes
				Detection Rate: 93.3 %



A D T

802.11ac (VHT40)

Type 4 Radar Statistical Performances				
Trial #	Test Frequency (MHz)	Pulse Width(us)	PRI(us)	Detection
1	5510	20	239	Yes
2	5520	12	465	Yes
3	5500	14.9	270	Yes
4	5519	15.7	233	No
5	5495	14.5	441	Yes
6	5506	17.5	231	Yes
7	5522	18	306	No
8	5509	17.7	389	No
9	5508	14	214	Yes
10	5515	16.1	415	Yes
11	5494	19.4	495	Yes
12	5524	19.3	343	Yes
13	5511	15.6	349	Yes
14	5492	16.9	393	Yes
15	5496	17.4	250	Yes
16	5508	14.8	425	Yes
17	5527	20	372	Yes
18	5526	11.3	476	Yes
19	5515	17.7	425	Yes
20	5515	17.5	347	Yes
21	5507	16.8	483	Yes
22	5514	17.4	350	Yes
23	5496	19.1	476	Yes
24	5522	19.3	365	No
25	5521	13	260	Yes
26	5498	19	303	Yes
27	5512	18	311	Yes
28	5526	19.8	493	Yes
29	5518	13.5	333	Yes
30	5503	13.6	478	Yes
				Detection Rate: 86.7 %



A D T

802.11ac (VHT40)

Type 5 Radar Statistical Performances

Trial #	Chirp Center Frequency(MHz)	Test Signal Name	Detection
1	5510	LP_Signal_01	Yes
2	5520	LP_Signal_02	Yes
3	5500	LP_Signal_03	Yes
4	5503	LP_Signal_04	Yes
5	5511	LP_Signal_05	Yes
6	5514	LP_Signal_06	Yes
7	5503	LP_Signal_07	Yes
8	5515	LP_Signal_08	Yes
9	5523	LP_Signal_09	No
10	5507	LP_Signal_10	Yes
11	5506	LP_Signal_11	Yes
12	5519	LP_Signal_12	Yes
13	5523	LP_Signal_13	Yes
14	5499	LP_Signal_14	No
15	5516	LP_Signal_15	Yes
16	5507	LP_Signal_16	Yes
17	5501	LP_Signal_17	Yes
18	5521	LP_Signal_18	Yes
19	5515	LP_Signal_19	Yes
20	5502	LP_Signal_20	Yes
21	5516	LP_Signal_21	Yes
22	5516	LP_Signal_22	Yes
23	5516	LP_Signal_23	Yes
24	5504	LP_Signal_24	Yes
25	5522	LP_Signal_25	No
26	5496	LP_Signal_26	Yes
27	5521	LP_Signal_27	Yes
28	5496	LP_Signal_28	Yes
29	5521	LP_Signal_29	Yes
30	5501	LP_Signal_30	Yes

Detection Rate: 90 %

The Long Pulse Radar pattern shown in Appendix B.1



A D T

802.11ac (VHT40)

Type 6 Radar Statistical Performances				
Trial #	Pulses per Burst	Pulse Width(us)	PRI(us)	Detection
1	9	1	333.3	Yes
2	9	1	333.3	Yes
3	9	1	333.3	Yes
4	9	1	333.3	Yes
5	9	1	333.3	Yes
6	9	1	333.3	Yes
7	9	1	333.3	Yes
8	9	1	333.3	Yes
9	9	1	333.3	Yes
10	9	1	333.3	Yes
11	9	1	333.3	Yes
12	9	1	333.3	Yes
13	9	1	333.3	Yes
14	9	1	333.3	Yes
15	9	1	333.3	Yes
16	9	1	333.3	Yes
17	9	1	333.3	Yes
18	9	1	333.3	Yes
19	9	1	333.3	Yes
20	9	1	333.3	Yes
21	9	1	333.3	Yes
22	9	1	333.3	Yes
23	9	1	333.3	Yes
24	9	1	333.3	Yes
25	9	1	333.3	Yes
26	9	1	333.3	Yes
27	9	1	333.3	Yes
28	9	1	333.3	Yes
29	9	1	333.3	Yes
30	9	1	333.3	Yes
				Detection Rate: 100 %



A D T

802.11ac (VHT40)

Type 6 Radar Statistical Performances		
Trial #	Hopping Frequency Sequence Name	Detection
1	HOP_FREQ_SEQ_01	Yes
2	HOP_FREQ_SEQ_02	Yes
3	HOP_FREQ_SEQ_03	Yes
4	HOP_FREQ_SEQ_04	Yes
5	HOP_FREQ_SEQ_05	Yes
6	HOP_FREQ_SEQ_06	Yes
7	HOP_FREQ_SEQ_07	Yes
8	HOP_FREQ_SEQ_08	Yes
9	HOP_FREQ_SEQ_09	Yes
10	HOP_FREQ_SEQ_10	Yes
11	HOP_FREQ_SEQ_11	Yes
12	HOP_FREQ_SEQ_12	Yes
13	HOP_FREQ_SEQ_13	Yes
14	HOP_FREQ_SEQ_14	Yes
15	HOP_FREQ_SEQ_15	Yes
16	HOP_FREQ_SEQ_16	Yes
17	HOP_FREQ_SEQ_17	Yes
18	HOP_FREQ_SEQ_18	Yes
19	HOP_FREQ_SEQ_19	Yes
20	HOP_FREQ_SEQ_20	Yes
21	HOP_FREQ_SEQ_21	Yes
22	HOP_FREQ_SEQ_22	Yes
23	HOP_FREQ_SEQ_23	Yes
24	HOP_FREQ_SEQ_24	Yes
25	HOP_FREQ_SEQ_25	Yes
26	HOP_FREQ_SEQ_26	Yes
27	HOP_FREQ_SEQ_27	Yes
28	HOP_FREQ_SEQ_28	Yes
29	HOP_FREQ_SEQ_29	Yes
30	HOP_FREQ_SEQ_30	Yes
		Detection Rate: 100 %

The Frequency Hopping Radar pattern shown in Appendix B.2



A D T

802.11ac (VHT80)

Type 1 Radar Statistical Performances

Trial #	Test Frequency (MHz)	Pulse Repetition Frequency (Pulse per seconds)	Pulses per Burst	Pulse Repetition Interval (microseconds)	Detection
1	5530	1139	61	878	Yes
2	5540	1567.4	83	638	Yes
3	5560	1792.1	95	558	Yes
4	5520	1165.6	62	858	Yes
5	5500	1253.1	67	798	Yes
6	5502	1519.8	81	658	Yes
7	5525	1432.7	76	698	Yes
8	5547	1730.1	92	578	Yes
9	5551	1618.1	86	618	Yes
10	5514	1319.3	70	758	Yes
11	5537	1858.7	99	538	Yes
12	5554	1222.5	65	818	Yes
13	5545	1193.3	63	838	Yes
14	5518	326.2	18	3066	Yes
15	5527	1355	72	738	Yes
16	5544	545.3	29	1834	Yes
17	5550	445	24	2247	Yes
18	5554	522.7	28	1913	Yes
19	5519	441.9	24	2263	Yes
20	5514	1455.6	77	687	Yes
21	5517	397.1	21	2518	Yes
22	5507	362.8	20	2756	Yes
23	5547	1572.3	83	636	Yes
24	5547	564	30	1773	Yes
25	5526	335.6	18	2980	Yes
26	5516	390.5	21	2561	Yes
27	5547	459.3	25	2177	Yes
28	5524	371.6	20	2691	Yes
29	5536	457.5	25	2186	Yes
30	5553	563.1	30	1776	Yes

Detection Rate: 100 %



A D T

802.11ac (VHT80)

Type 2 Radar Statistical Performances

Trial #	Test Frequency (MHz)	Pulse Width(us)	PRI(us)	Detection
1	5530	2.4	154	Yes
2	5540	3.1	173	Yes
3	5560	2.3	185	Yes
4	5520	3.9	229	Yes
5	5500	3.6	190	Yes
6	5522	2.8	176	Yes
7	5552	3.3	188	Yes
8	5524	3.8	224	Yes
9	5540	4.2	187	Yes
10	5522	3.1	157	Yes
11	5530	2.8	212	Yes
12	5527	4.6	212	Yes
13	5524	3.7	224	Yes
14	5553	3	194	Yes
15	5534	1	175	Yes
16	5545	1.4	193	Yes
17	5532	4.8	186	No
18	5526	3.8	199	No
19	5523	1.8	162	Yes
20	5538	1.2	203	Yes
21	5536	4.4	159	Yes
22	5555	1.1	189	Yes
23	5524	2.3	215	Yes
24	5525	3.1	214	Yes
25	5550	3.4	197	Yes
26	5523	3.4	186	Yes
27	5500	2.9	205	Yes
28	5514	3.4	216	Yes
29	5503	4	221	Yes
30	5542	2.5	220	Yes

Detection Rate: 93.3 %



A D T

802.11ac (VHT80)

Type 3 Radar Statistical Performances

Trial #	Test Frequency (MHz)	Pulse Width(us)	PRI(us)	Detection
1	5530	6.3	407	No
2	5540	8.1	457	Yes
3	5560	7	351	Yes
4	5520	7.2	238	Yes
5	5500	9	256	Yes
6	5546	6.6	466	Yes
7	5558	7.2	454	Yes
8	5543	6.2	215	Yes
9	5503	9.8	221	No
10	5515	6.8	291	Yes
11	5511	6.2	214	No
12	5524	6.3	486	Yes
13	5513	8.9	374	Yes
14	5500	8.6	304	Yes
15	5505	8.3	400	Yes
16	5501	7.1	291	Yes
17	5549	6.9	259	Yes
18	5501	9.9	497	Yes
19	5509	6.2	323	Yes
20	5513	9	311	Yes
21	5520	6.9	428	Yes
22	5533	9.9	226	No
23	5519	6.9	443	Yes
24	5556	6.3	493	Yes
25	5549	8.9	452	Yes
26	5528	7.9	464	No
27	5527	6.9	272	Yes
28	5508	7.2	317	No
29	5518	9.9	223	Yes
30	5503	7.3	477	Yes

Detection Rate: 80.0 %



A D T

802.11ac (VHT80)

Type 4 Radar Statistical Performances

Trial #	Test Frequency (MHz)	Pulse Width(us)	PRI(us)	Detection
1	5530	20	239	Yes
2	5540	12	465	Yes
3	5560	14.9	270	Yes
4	5520	15.7	233	Yes
5	5500	14.5	441	Yes
6	5502	17.5	231	Yes
7	5550	18	306	Yes
8	5535	17.7	389	Yes
9	5537	14	214	Yes
10	5517	16.1	415	No
11	5524	19.4	495	Yes
12	5547	19.3	343	Yes
13	5533	15.6	349	Yes
14	5547	16.9	393	Yes
15	5520	17.4	250	Yes
16	5535	14.8	425	Yes
17	5530	20	372	Yes
18	5514	11.3	476	No
19	5545	17.7	425	No
20	5525	17.5	347	No
21	5512	16.8	483	Yes
22	5520	17.4	350	No
23	5505	19.1	476	Yes
24	5527	19.3	365	No
25	5557	13	260	Yes
26	5556	19	303	Yes
27	5559	18	311	Yes
28	5501	19.8	493	Yes
29	5523	13.5	333	Yes
30	5532	13.6	478	Yes

Detection Rate: 80.0 %



A D T

802.11ac (VHT80)

Type 5 Radar Statistical Performances

Trial #	Chirp Center Frequency(MHz)	Test Signal Name	Detection
1	5530	LP_Signal_01	Yes
2	5540	LP_Signal_02	Yes
3	5560	LP_Signal_03	No
4	5520	LP_Signal_04	Yes
5	5500	LP_Signal_05	Yes
6	5541	LP_Signal_06	Yes
7	5513	LP_Signal_07	Yes
8	5551	LP_Signal_08	Yes
9	5538	LP_Signal_09	Yes
10	5525	LP_Signal_10	Yes
11	5517	LP_Signal_11	Yes
12	5550	LP_Signal_12	Yes
13	5559	LP_Signal_13	Yes
14	5523	LP_Signal_14	Yes
15	5526	LP_Signal_15	Yes
16	5542	LP_Signal_16	Yes
17	5511	LP_Signal_17	Yes
18	5515	LP_Signal_18	Yes
19	5512	LP_Signal_19	No
20	5550	LP_Signal_20	Yes
21	5522	LP_Signal_21	Yes
22	5552	LP_Signal_22	Yes
23	5531	LP_Signal_23	Yes
24	5514	LP_Signal_24	Yes
25	5527	LP_Signal_25	No
26	5512	LP_Signal_26	Yes
27	5519	LP_Signal_27	Yes
28	5513	LP_Signal_28	Yes
29	5551	LP_Signal_29	Yes
30	5511	LP_Signal_30	Yes

Detection Rate: 90 %

The Long Pulse Radar pattern shown in Appendix B.1



A D T

802.11ac (VHT80)

Type 6 Radar Statistical Performances				
Trial #	Pulses per Burst	Pulse Width(us)	PRI(us)	Detection
1	9	1	333.3	Yes
2	9	1	333.3	Yes
3	9	1	333.3	Yes
4	9	1	333.3	Yes
5	9	1	333.3	Yes
6	9	1	333.3	Yes
7	9	1	333.3	Yes
8	9	1	333.3	Yes
9	9	1	333.3	Yes
10	9	1	333.3	Yes
11	9	1	333.3	Yes
12	9	1	333.3	Yes
13	9	1	333.3	Yes
14	9	1	333.3	Yes
15	9	1	333.3	Yes
16	9	1	333.3	Yes
17	9	1	333.3	Yes
18	9	1	333.3	Yes
19	9	1	333.3	Yes
20	9	1	333.3	Yes
21	9	1	333.3	Yes
22	9	1	333.3	Yes
23	9	1	333.3	Yes
24	9	1	333.3	Yes
25	9	1	333.3	Yes
26	9	1	333.3	Yes
27	9	1	333.3	Yes
28	9	1	333.3	Yes
29	9	1	333.3	Yes
30	9	1	333.3	Yes
Detection Rate: 100 %				



A D T

802.11ac (VHT80)

Type 6 Radar Statistical Performances

Trial #	Hopping Frequency Sequence Name	Detection
1	HOP_FREQ_SEQ_01	Yes
2	HOP_FREQ_SEQ_02	Yes
3	HOP_FREQ_SEQ_03	Yes
4	HOP_FREQ_SEQ_04	Yes
5	HOP_FREQ_SEQ_05	Yes
6	HOP_FREQ_SEQ_06	Yes
7	HOP_FREQ_SEQ_07	Yes
8	HOP_FREQ_SEQ_08	Yes
9	HOP_FREQ_SEQ_09	Yes
10	HOP_FREQ_SEQ_10	Yes
11	HOP_FREQ_SEQ_11	Yes
12	HOP_FREQ_SEQ_12	Yes
13	HOP_FREQ_SEQ_13	Yes
14	HOP_FREQ_SEQ_14	Yes
15	HOP_FREQ_SEQ_15	Yes
16	HOP_FREQ_SEQ_16	Yes
17	HOP_FREQ_SEQ_17	Yes
18	HOP_FREQ_SEQ_18	Yes
19	HOP_FREQ_SEQ_19	Yes
20	HOP_FREQ_SEQ_20	Yes
21	HOP_FREQ_SEQ_21	Yes
22	HOP_FREQ_SEQ_22	Yes
23	HOP_FREQ_SEQ_23	Yes
24	HOP_FREQ_SEQ_24	Yes
25	HOP_FREQ_SEQ_25	Yes
26	HOP_FREQ_SEQ_26	Yes
27	HOP_FREQ_SEQ_27	Yes
28	HOP_FREQ_SEQ_28	Yes
29	HOP_FREQ_SEQ_29	Yes
30	HOP_FREQ_SEQ_30	Yes

Detection Rate: 100 %

The Frequency Hopping Radar pattern shown in Appendix B.2

6.2.1.4 NON- OCCUPANCY PERIOD

1) Test results demonstrating an associated client link is established with the master on a test frequency.

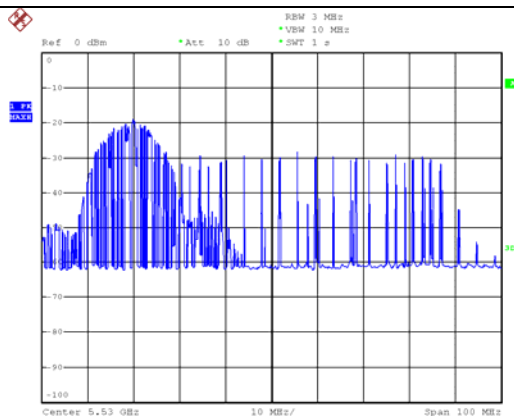

EUT (master) links with Client on 5530MHz

2) The master and DFS-certified client device are associated, and system testing will be performed with channel-loading for a non-occupancy period test.

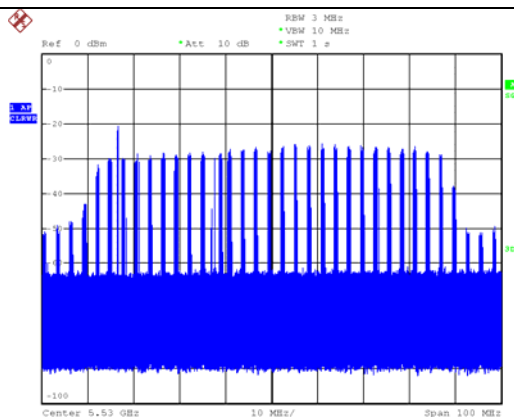

Master performed with channel-loading via Client.

3). The device transmits one type of radar as specified in the DFS Order.

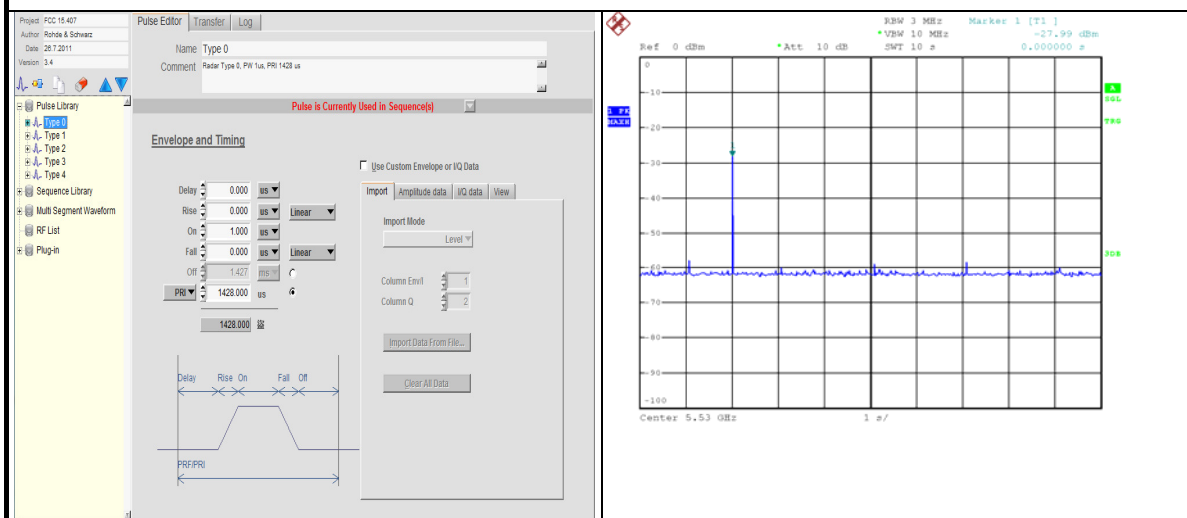

Radar 0 is used to test during DFS testing.

4) The test frequency has been monitored to ensure no transmission of any type has occurred for 30 minutes;

Note: If the client moves with the master, the device is considered compliant if nothing appears in the client non-occupancy period test. For devices that shut down (rather than moving channels), no beacons should appear;

5)An analyzer plot that contains a single 30-minute sweep on the original test frequency.

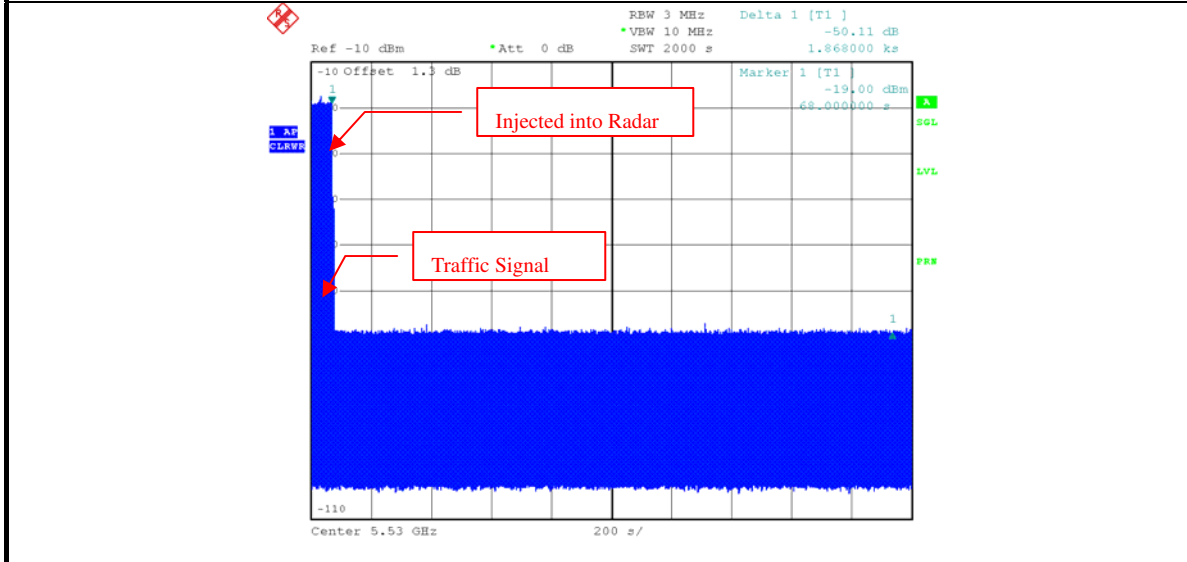



A D T

6.2.1.6 U-NII DETECTION BANDWIDTH

802.11ac (VHT20)

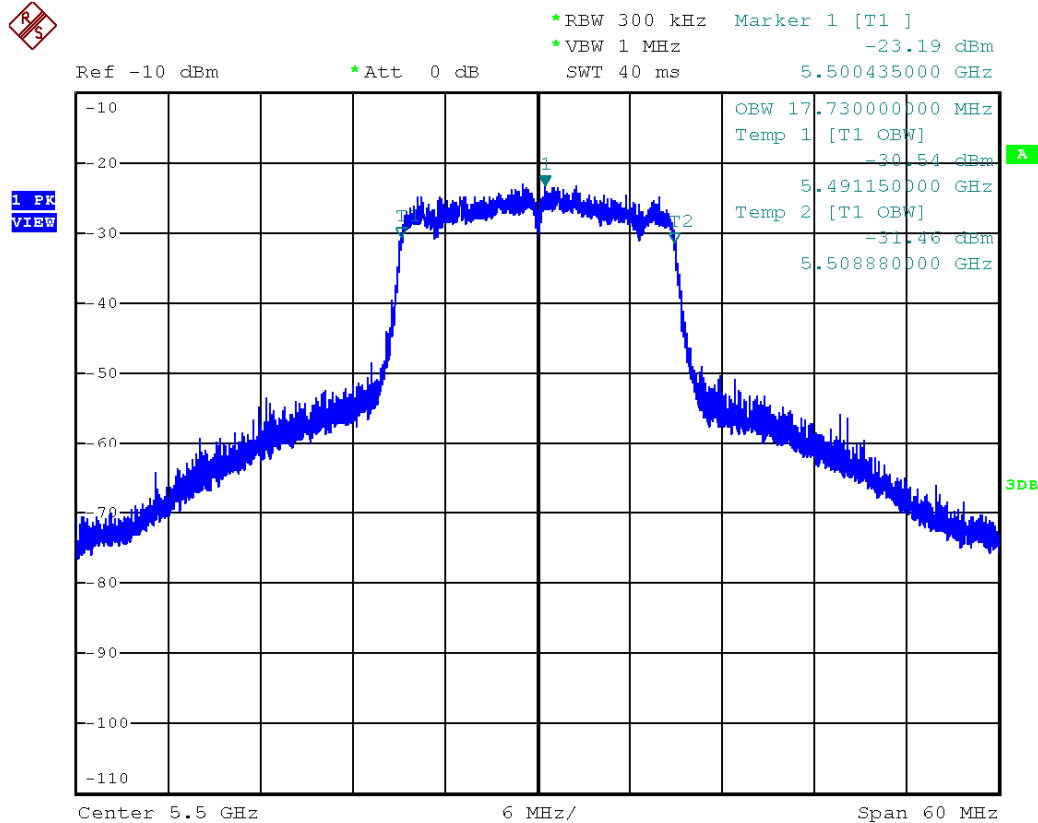

U-NII 99% Channel bandwidth



802.11ac (VHT20)

Detection Bandwidth Test											
EUT Frequency: 5.500GHz											
EUT 99% Power bandwidth: 17.73MHz											
Detection bandwidth limit (100% of EUT 99% Power bandwidth): 17.73MHz											
Detection Bandwidth (FH - FL): 18.00MHz											
Test Result : PASS											
Radar Frequency (Hz)	Trial Number / Detection										Detection Rate (%)
	1	2	3	4	5	6	7	8	9	10	
5.488G	No	No	No	No	No	No	No	No	No	No	0
5.489G	No	No	No	No	No	No	No	No	No	No	0
5.490G	No	No	No	No	No	No	No	No	No	No	0
5.491G (FL)	Yes	Yes	Yes	Yes	Yes	Yes	Yes	Yes	Yes	Yes	100
5.492G	Yes	Yes	Yes	Yes	Yes	Yes	Yes	Yes	Yes	Yes	100
5.493G	Yes	Yes	Yes	Yes	Yes	Yes	Yes	Yes	Yes	Yes	100
5.494G	Yes	Yes	Yes	Yes	Yes	Yes	Yes	Yes	Yes	Yes	100
5.495G	Yes	Yes	Yes	Yes	Yes	Yes	Yes	Yes	Yes	Yes	100
5.496G	Yes	Yes	Yes	Yes	Yes	Yes	Yes	Yes	Yes	Yes	100
5.497G	Yes	Yes	Yes	Yes	Yes	Yes	Yes	Yes	Yes	Yes	100
5.498G	Yes	Yes	Yes	Yes	Yes	Yes	Yes	Yes	Yes	Yes	100
5.499G	Yes	Yes	Yes	Yes	Yes	Yes	Yes	Yes	Yes	Yes	100
5.500G	Yes	Yes	Yes	Yes	Yes	Yes	Yes	Yes	Yes	Yes	100
5.501G	Yes	Yes	Yes	Yes	Yes	Yes	Yes	Yes	Yes	Yes	100
5.502G	Yes	Yes	Yes	Yes	Yes	Yes	Yes	Yes	Yes	Yes	100
5.503G	Yes	Yes	Yes	Yes	Yes	Yes	Yes	Yes	Yes	Yes	100
5.504G	Yes	Yes	Yes	Yes	Yes	Yes	Yes	Yes	Yes	Yes	100
5.505G	Yes	Yes	Yes	Yes	Yes	Yes	Yes	Yes	Yes	Yes	100
5.506G	Yes	Yes	Yes	Yes	Yes	Yes	Yes	Yes	Yes	Yes	100
5.507G	Yes	Yes	Yes	Yes	Yes	Yes	Yes	Yes	Yes	Yes	100
5.508G	Yes	Yes	Yes	Yes	Yes	Yes	Yes	Yes	Yes	Yes	100
5.509G (FH)	Yes	Yes	Yes	Yes	Yes	Yes	Yes	Yes	Yes	Yes	100
5.510G	No	No	No	No	No	No	No	No	No	No	0
5.511G	No	No	No	No	No	No	No	No	No	No	0
5.512G	No	No	No	No	No	No	No	No	No	No	0



A D T

802.11ac (VHT40)



*RBW 300 kHz Marker 1 [T1]
-23.80 dBm
*VBW 1 MHz
SWT 40 ms 5.497775000 GHz

Ref -10 dBm

*Att 0 dB

1 PK
VIEW

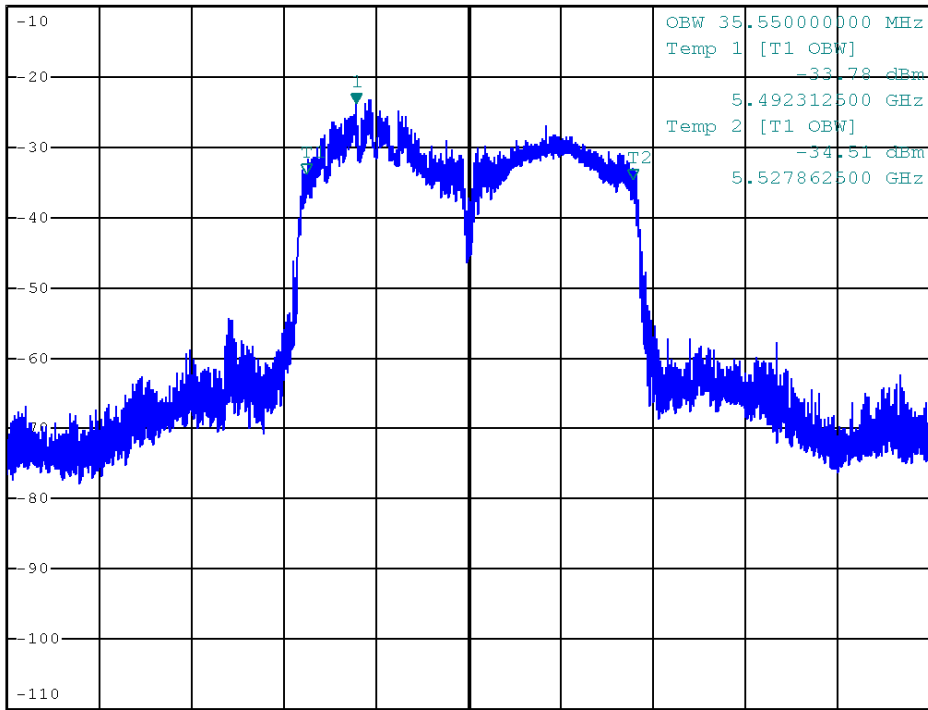

Center 5.51 GHz

10 MHz/

Span 100 MHz

U-NII 99% Channel bandwidth



802.11ac (VHT40)

Detection Bandwidth Test											
EUT Frequency: 5.510GHz											
EUT 99% Power bandwidth: 35.55MHz											
Detection bandwidth limit (100% of EUT 99% Power bandwidth): 35.55MHz											
Detection Bandwidth (FH - FL): 36MHz											
Test Result : PASS											
Radar Frequency (Hz)	Trial Number / Detection										Detection Rate (%)
	1	2	3	4	5	6	7	8	9	10	
5.489G	No	No	No	No	No	No	No	No	No	No	0
5.490G	No	No	No	No	No	No	No	No	No	No	0
5.491G	No	No	No	No	No	No	No	No	No	No	0
5.492G (FL)	Yes	Yes	Yes	Yes	Yes	Yes	Yes	Yes	Yes	Yes	100
5.493G	Yes	Yes	Yes	Yes	Yes	Yes	Yes	Yes	Yes	Yes	100
5.494G	Yes	Yes	Yes	Yes	Yes	Yes	Yes	Yes	Yes	Yes	100
5.495G	Yes	Yes	Yes	Yes	Yes	Yes	Yes	Yes	Yes	Yes	100
5.496G	Yes	Yes	Yes	Yes	Yes	Yes	Yes	Yes	Yes	Yes	100
5.497G	Yes	Yes	Yes	Yes	Yes	Yes	Yes	Yes	Yes	Yes	100
5.498G	Yes	Yes	Yes	Yes	Yes	Yes	Yes	Yes	Yes	Yes	100
5.499G	Yes	Yes	Yes	Yes	Yes	Yes	Yes	Yes	Yes	Yes	100
5.500G	Yes	Yes	Yes	Yes	Yes	Yes	Yes	Yes	Yes	Yes	100
5.501G	Yes	Yes	Yes	Yes	Yes	Yes	Yes	Yes	Yes	Yes	100
5.502G	Yes	Yes	Yes	Yes	Yes	Yes	Yes	Yes	Yes	Yes	100
5.503G	Yes	Yes	Yes	Yes	Yes	Yes	Yes	Yes	Yes	Yes	100
5.504G	Yes	Yes	Yes	Yes	Yes	Yes	Yes	Yes	Yes	Yes	100
5.505G	Yes	Yes	Yes	Yes	Yes	Yes	Yes	Yes	Yes	Yes	100
5.506G	Yes	Yes	Yes	Yes	Yes	Yes	Yes	Yes	Yes	Yes	100
5.507G	Yes	Yes	Yes	Yes	Yes	Yes	Yes	Yes	Yes	Yes	100
5.508G	Yes	Yes	Yes	Yes	Yes	Yes	Yes	Yes	Yes	Yes	100
5.509G	Yes	Yes	Yes	Yes	Yes	Yes	Yes	Yes	Yes	Yes	100
5.510G	Yes	Yes	Yes	Yes	Yes	Yes	Yes	Yes	Yes	Yes	100
5.511G	Yes	Yes	Yes	Yes	Yes	Yes	Yes	Yes	Yes	Yes	100
5.512G	Yes	Yes	Yes	Yes	Yes	Yes	Yes	Yes	Yes	Yes	100
5.513G	Yes	Yes	Yes	Yes	Yes	Yes	Yes	Yes	Yes	Yes	100
5.514G	Yes	Yes	Yes	Yes	Yes	Yes	Yes	Yes	Yes	Yes	100
5.515G	Yes	Yes	Yes	Yes	Yes	Yes	Yes	Yes	Yes	Yes	100
5.516G	Yes	Yes	Yes	Yes	Yes	Yes	Yes	Yes	Yes	Yes	100
5.517G	Yes	Yes	Yes	Yes	Yes	Yes	Yes	Yes	Yes	Yes	100
5.518G	Yes	Yes	Yes	Yes	Yes	Yes	Yes	Yes	Yes	Yes	100
5.519G	Yes	Yes	Yes	Yes	Yes	Yes	Yes	Yes	Yes	Yes	100
5.520G	Yes	Yes	Yes	Yes	Yes	Yes	Yes	Yes	Yes	Yes	100
5.521G	Yes	Yes	Yes	Yes	Yes	Yes	Yes	Yes	Yes	Yes	100
5.522G	Yes	Yes	Yes	Yes	Yes	Yes	Yes	Yes	Yes	Yes	100
5.523G	Yes	Yes	Yes	Yes	Yes	Yes	Yes	Yes	Yes	Yes	100
5.524G	Yes	Yes	Yes	Yes	Yes	Yes	Yes	Yes	Yes	Yes	100
5.525G	Yes	Yes	Yes	Yes	Yes	Yes	Yes	Yes	Yes	Yes	100
5.526G	Yes	Yes	Yes	Yes	Yes	Yes	Yes	Yes	Yes	Yes	100
5.527G	Yes	Yes	Yes	Yes	Yes	Yes	Yes	Yes	Yes	Yes	100
5.528G (FH)	Yes	Yes	Yes	Yes	Yes	Yes	Yes	Yes	Yes	Yes	100
5.529G	No	No	No	No	No	No	No	No	No	No	0
5.530G	No	No	No	No	No	No	No	No	No	No	0
5.531G	No	No	No	No	No	No	No	No	No	No	0



A D T

802.11ac (VHT80)



Ref -10 dBm *Att 0 dB *RBW 300 kHz Marker 1 [T1]
*VBW 1 MHz -28.75 dBm
SWT 40 ms 5.504560000 GHz

1 PK
VIEW

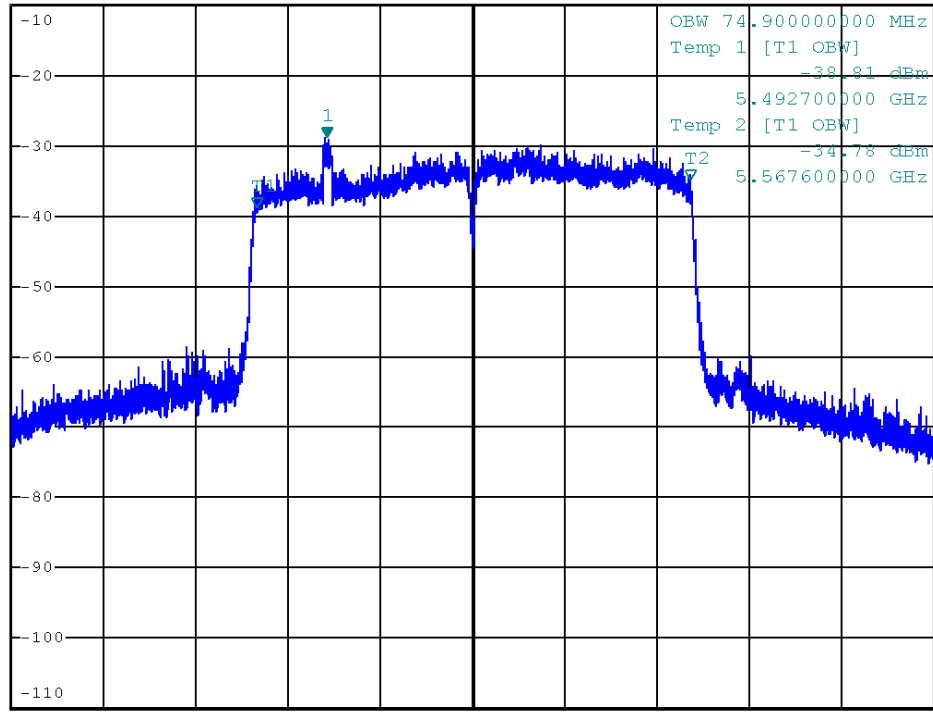

Center 5.53 GHz 16 MHz/ Span 160 MHz

U-NII 99% Channel bandwidth



A D T

802.11ac (VHT80)

Detection Bandwidth Test											
EUT Frequency: 5.530GHz											
EUT 99% Power bandwidth: 74.9MHz											
Detection bandwidth limit (100% of EUT 99% Power bandwidth): 74.9MHz											
Detection Bandwidth (FH - FL): 76MHz											
Test Result : PASS											
Radar Frequency (Hz)	Trial Number / Detection										Detection Rate (%)
	1	2	3	4	5	6	7	8	9	10	
5.489G	No	No	No	No	No	No	No	No	No	No	0
5.490G	No	No	No	No	No	No	No	No	No	No	0
5.491G	No	No	No	No	No	No	No	No	No	No	0
5.492G (FL)	Yes	Yes	Yes	Yes	Yes	Yes	Yes	Yes	Yes	Yes	100
5.493G	Yes	Yes	Yes	Yes	Yes	Yes	Yes	Yes	Yes	Yes	100
5.494G	Yes	Yes	Yes	Yes	Yes	Yes	Yes	Yes	Yes	Yes	100
5.495G	Yes	Yes	Yes	Yes	Yes	Yes	Yes	Yes	Yes	Yes	100
5.496G	Yes	Yes	Yes	Yes	Yes	Yes	Yes	Yes	Yes	Yes	100
5.497G	Yes	Yes	Yes	Yes	Yes	Yes	Yes	Yes	Yes	Yes	100
5.498G	Yes	Yes	Yes	Yes	Yes	Yes	Yes	Yes	Yes	Yes	100
5.499G	Yes	Yes	Yes	Yes	Yes	Yes	Yes	Yes	Yes	Yes	100
5.500G	Yes	Yes	Yes	Yes	Yes	Yes	Yes	Yes	Yes	Yes	100
5.501G	Yes	Yes	Yes	Yes	Yes	Yes	Yes	Yes	Yes	Yes	100
5.502G	Yes	Yes	Yes	Yes	Yes	Yes	Yes	Yes	Yes	Yes	100
5.503G	Yes	Yes	Yes	Yes	Yes	Yes	Yes	Yes	Yes	Yes	100
5.504G	Yes	Yes	Yes	Yes	Yes	Yes	Yes	Yes	Yes	Yes	100
5.505G	Yes	Yes	Yes	Yes	Yes	Yes	Yes	Yes	Yes	Yes	100
5.506G	Yes	Yes	Yes	Yes	Yes	Yes	Yes	Yes	Yes	Yes	100
5.507G	Yes	Yes	Yes	Yes	Yes	Yes	Yes	Yes	Yes	Yes	100
5.508G	Yes	Yes	Yes	Yes	Yes	Yes	Yes	Yes	Yes	Yes	100
5.509G	Yes	Yes	Yes	Yes	Yes	Yes	Yes	Yes	Yes	Yes	100
5.510G	Yes	Yes	Yes	Yes	Yes	Yes	Yes	Yes	Yes	Yes	100
5.511G	Yes	Yes	Yes	Yes	Yes	Yes	Yes	Yes	Yes	Yes	100
5.512G	Yes	Yes	Yes	Yes	Yes	Yes	Yes	Yes	Yes	Yes	100
5.513G	Yes	Yes	Yes	Yes	Yes	Yes	Yes	Yes	Yes	Yes	100
5.514G	Yes	Yes	Yes	Yes	Yes	Yes	Yes	Yes	Yes	Yes	100
5.515G	Yes	Yes	Yes	Yes	Yes	Yes	Yes	Yes	Yes	Yes	100
5.516G	Yes	Yes	Yes	Yes	Yes	Yes	Yes	Yes	Yes	Yes	100
5.517G	Yes	Yes	Yes	Yes	Yes	Yes	Yes	Yes	Yes	Yes	100
5.518G	Yes	Yes	Yes	Yes	Yes	Yes	Yes	Yes	Yes	Yes	100
5.519G	Yes	Yes	Yes	Yes	Yes	Yes	Yes	Yes	Yes	Yes	100
5.520G	Yes	Yes	Yes	Yes	Yes	Yes	Yes	Yes	Yes	Yes	100
5.521G	Yes	Yes	Yes	Yes	Yes	Yes	Yes	Yes	Yes	Yes	100
5.522G	Yes	Yes	Yes	Yes	Yes	Yes	Yes	Yes	Yes	Yes	100
5.523G	Yes	Yes	Yes	Yes	Yes	Yes	Yes	Yes	Yes	Yes	100
5.524G	Yes	Yes	Yes	Yes	Yes	Yes	Yes	Yes	Yes	Yes	100
5.525G	Yes	Yes	Yes	Yes	Yes	Yes	Yes	Yes	Yes	Yes	100
5.526G	Yes	Yes	Yes	Yes	Yes	Yes	Yes	Yes	Yes	Yes	100
5.527G	Yes	Yes	Yes	Yes	Yes	Yes	Yes	Yes	Yes	Yes	100
5.528G	Yes	Yes	Yes	Yes	Yes	Yes	Yes	Yes	Yes	Yes	100
5.529G	Yes	Yes	Yes	Yes	Yes	Yes	Yes	Yes	Yes	Yes	100
5.530G	Yes	Yes	Yes	Yes	Yes	Yes	Yes	Yes	Yes	Yes	100
5.531G	Yes	Yes	Yes	Yes	Yes	Yes	Yes	Yes	Yes	Yes	100



A D T

5.532G	Yes	Yes	Yes	Yes	Yes	Yes	Yes	Yes	Yes	Yes	100
5.533G	Yes	Yes	Yes	Yes	Yes	Yes	Yes	Yes	Yes	Yes	100
5.534G	Yes	Yes	Yes	Yes	Yes	Yes	Yes	Yes	Yes	Yes	100
5.535G	Yes	Yes	Yes	Yes	Yes	Yes	Yes	Yes	Yes	Yes	100
5.536G	Yes	Yes	Yes	Yes	Yes	Yes	Yes	Yes	Yes	Yes	100
5.537G	Yes	Yes	Yes	Yes	Yes	Yes	Yes	Yes	Yes	Yes	100
5.538G	Yes	Yes	Yes	Yes	Yes	Yes	Yes	Yes	Yes	Yes	100
5.539G	Yes	Yes	Yes	Yes	Yes	Yes	Yes	Yes	Yes	Yes	100
5.540G	Yes	Yes	Yes	Yes	Yes	Yes	Yes	Yes	Yes	Yes	100
5.541G	Yes	Yes	Yes	Yes	Yes	Yes	Yes	Yes	Yes	Yes	100
5.542G	Yes	Yes	Yes	Yes	Yes	Yes	Yes	Yes	Yes	Yes	100
5.543G	Yes	Yes	Yes	Yes	Yes	Yes	Yes	Yes	Yes	Yes	100
5.544G	Yes	Yes	Yes	Yes	Yes	Yes	Yes	Yes	Yes	Yes	100
5.545G	Yes	Yes	Yes	Yes	Yes	Yes	Yes	Yes	Yes	Yes	100
5.546G	Yes	Yes	Yes	Yes	Yes	Yes	Yes	Yes	Yes	Yes	100
5.547G	Yes	Yes	Yes	Yes	Yes	Yes	Yes	Yes	Yes	Yes	100
5.548G	Yes	Yes	Yes	Yes	Yes	Yes	Yes	Yes	Yes	Yes	100
5.549G	Yes	Yes	Yes	Yes	Yes	Yes	Yes	Yes	Yes	Yes	100
5.550G	Yes	Yes	Yes	Yes	Yes	Yes	Yes	Yes	Yes	Yes	100
5.551G	Yes	Yes	Yes	Yes	Yes	Yes	Yes	Yes	Yes	Yes	100
5.552G	Yes	Yes	Yes	Yes	Yes	Yes	Yes	Yes	Yes	Yes	100
5.553G	Yes	Yes	Yes	Yes	Yes	Yes	Yes	Yes	Yes	Yes	100
5.554G	Yes	Yes	Yes	Yes	Yes	Yes	Yes	Yes	Yes	Yes	100
5.555G	Yes	Yes	Yes	Yes	Yes	Yes	Yes	Yes	Yes	Yes	100
5.556G	Yes	Yes	Yes	Yes	Yes	Yes	Yes	Yes	Yes	Yes	100
5.557G	Yes	Yes	Yes	Yes	Yes	Yes	Yes	Yes	Yes	Yes	100
5.558G	Yes	Yes	Yes	Yes	Yes	Yes	Yes	Yes	Yes	Yes	100
5.559G	Yes	Yes	Yes	Yes	Yes	Yes	Yes	Yes	Yes	Yes	100
5.560G	Yes	Yes	Yes	Yes	Yes	Yes	Yes	Yes	Yes	Yes	100
5.561G	Yes	Yes	Yes	Yes	Yes	Yes	Yes	Yes	Yes	Yes	100
5.562G	Yes	Yes	Yes	Yes	Yes	Yes	Yes	Yes	Yes	Yes	100
5.563G	Yes	Yes	Yes	Yes	Yes	Yes	Yes	Yes	Yes	Yes	100
5.564G	Yes	Yes	Yes	Yes	Yes	Yes	Yes	Yes	Yes	Yes	100
5.565G	Yes	Yes	Yes	Yes	Yes	Yes	Yes	Yes	Yes	Yes	100
5.566G	Yes	Yes	Yes	Yes	Yes	Yes	Yes	Yes	Yes	Yes	100
5.567G	Yes	Yes	Yes	Yes	Yes	Yes	Yes	Yes	Yes	Yes	100
5.568G (FH)	Yes	Yes	Yes	Yes	Yes	Yes	Yes	Yes	Yes	Yes	100
5.569G	No	No	No	No	No	No	No	No	No	No	0
5.570G	No	No	No	No	No	No	No	No	No	No	0
5.571G	No	No	No	No	No	No	No	No	No	No	0



A D T

6.2.1.7 NON-CO-CHANNEL TEST

The UUT was investigated after radar was detected the channel and made sure no co-channel operation with radars.



A D T

7. INFORMATION ON THE TESTING LABORATORIES

We, Bureau Veritas Consumer Products Services (H.K.) Ltd., Taoyuan Branch, were founded in 1988 to provide our best service in EMC, Radio, Telecom and Safety consultation. Our laboratories are accredited and approved according to ISO/IEC 17025:

If you have any comments, please feel free to contact us at the following:

Linko EMC/RF Lab:

Tel: 886-2-26052180

Fax: 886-2-26052943

Hsin Chu EMC/RF/Telecom Lab:

Tel: 886-3-6668565

Fax: 886-3-6668323

Hwa Ya EMC/RF/Safety Lab:

Tel: 886-3-3183232

Fax: 886-3-3270892

Email: service.adt@tw.bureauveritas.com

Web Site: www.bureauveritas-adt.com

The address and road map of all our labs can be found in our web site also.



A D T

8. APPENDIX A - MODIFICATIONS RECORDERS FOR ENGINEERING CHANGES TO THE EUT BY THE LAB

Modifications or adding components during the test

No any modifications are made to the EUT by the lab during the test.



9. APPENDIX-B

RADAR TEST SIGNAL

B.1 The Long Pulse Radar Pattern

Long Pulse Radar Test Signal
Test Signal Name: LP_Signal_01

Bursts in Trial: 8

Burst	Number of Pulses	Pulse Width (µsec)	Chirp Width (MHz)	Pulse 1-to-2 Spacing (µsec)	Pulse 2-to-3 Spacing (µsec)	Start Location Within Interval (msec)
1	3	78.1	10	1533	1901	561
2	2	95	5	1298		680
3	3	65	6	1668	1324	447
4	2	59.8	9	1081		78
5	2	52.1	6	1475		1208
6	2	72.4	18	1748		1365
7	2	84.3	6	974		1317
8	2	58.4	20	1844		1074

Long Pulse Radar Test Signal
Test Signal Name: LP_Signal_02

Bursts in Trial: 9

Burst	Number of Pulses	Pulse Width (µsec)	Chirp Width (MHz)	Pulse 1-to-2 Spacing (µsec)	Pulse 2-to-3 Spacing (µsec)	Start Location Within Interval (msec)
1	3	51.4	18	1075	1711	595
2	1	75.9	8			1196
3	2	71.6	9	1396		519
4	2	87.3	7	1475		594
5	2	69.8	6	1840		867
6	2	88.7	14	1175		496
7	2	54.1	10	1248		10
8	2	99.9	9	1609		394
9	1	87.2	13			1109



A D T

Long Pulse Radar Test Signal

Test Signal Name: LP_Signal_03

Bursts in Trial: 10

Burst	Number of Pulses	Pulse Width (μ sec)	Chirp Width (MHz)	Pulse 1-to-2 Spacing (μ sec)	Pulse 2-to-3 Spacing (μ sec)	Start Location Within Interval (msec)
1	1	54.1	14			395
2	1	97.5	8			365
3	2	61.8	7	1892		1097
4	1	100	11			492
5	2	77.9	5	1631		17
6	3	72.6	19	1160	1507	99
7	2	66.3	15	1624		118
8	3	78	17	1018	1247	781
9	2	79.6	19	963		179
10	1	63.7	20			1146

Long Pulse Radar Test Signal

Test Signal Name: LP_Signal_04

Bursts in Trial: 11

Burst	Number of Pulses	Pulse Width (μ sec)	Chirp Width (MHz)	Pulse 1-to-2 Spacing (μ sec)	Pulse 2-to-3 Spacing (μ sec)	Start Location Within Interval (msec)
1	1	50.4	6			78
2	2	81.5	8	1789		332
3	2	91.4	13	1307		526
4	2	64.9	19	1404		915
5	2	68.8	18	1329		658
6	1	95.4	13			1056
7	2	68.5	15	941		894
8	1	93.1	15			635
9	1	97.5	14			749
10	2	64.3	17	1665		1077
11	3	84.2	5	1548	1338	771



A D T

Long Pulse Radar Test Signal

Test Signal Name: LP_Signal_05

Bursts in Trial: 12

Burst	Number of Pulses	Pulse Width (µsec)	Chirp Width (MHz)	Pulse 1-to-2 Spacing (µsec)	Pulse 2-to-3 Spacing (µsec)	Start Location Within Interval (msec)
1	2	72.4	13	1488		465
2	3	54.5	12	1682	1341	300
3	2	64.4	7	1111		269
4	2	68.5	15	1917		85
5	1	76.4	15			687
6	3	51	12	1789	1245	60
7	1	85.4	8			367
8	3	91.2	6	984	1348	504
9	3	98.1	20	1155	978	602
10	3	61.1	8	1878	1851	654
11	3	90.7	15	948	1642	522
12	2	96.3	14	1056		731

Long Pulse Radar Test Signal

Test Signal Name: LP_Signal_06

Bursts in Trial: 8

Burst	Number of Pulses	Pulse Width (µsec)	Chirp Width (MHz)	Pulse 1-to-2 Spacing (µsec)	Pulse 2-to-3 Spacing (µsec)	Start Location Within Interval (msec)
1	2	98	12	1486		495
2	3	88.3	13	1014	1136	940
3	3	96.9	6	927	1201	198
4	3	64.6	13	969	1070	128
5	3	96	12	1839	1566	1327
6	2	68.7	6	995		949
7	2	62	7	1162		77
8	2	83.2	9	1846		1000



A D T

Long Pulse Radar Test Signal

Test Signal Name: LP_Signal_07

Bursts in Trial: 14

Burst	Number of Pulses	Pulse Width (µsec)	Chirp Width (MHz)	Pulse 1-to-2 Spacing (µsec)	Pulse 2-to-3 Spacing (µsec)	Start Location Within Interval (msec)
1	1	52.9	14			681
2	1	93.4	17			340
3	2	62.6	15	1831		628
4	2	67	5	1018		484
5	2	74.9	15	1847		611
6	3	95	9	1021	1894	108
7	3	88.2	6	1818	1149	735
8	2	60.9	6	959		665
9	2	57.6	14	1121		365
10	2	50.8	6	1624		490
11	1	68.2	5			275
12	3	92.3	13	994	964	401
13	1	58.6	11			182
14	2	98.2	10	1642		627

Long Pulse Radar Test Signal

Test Signal Name: LP_Signal_08

Bursts in Trial: 15

Burst	Number of Pulses	Pulse Width (µsec)	Chirp Width (MHz)	Pulse 1-to-2 Spacing (µsec)	Pulse 2-to-3 Spacing (µsec)	Start Location Within Interval (msec)
1	2	88.5	11	1384		538
2	2	74.9	14	1156		693
3	2	78.9	19	987		702
4	3	81.4	13	1887	1130	640
5	1	64.7	13			446
6	2	52.6	20	1269		701
7	2	87.1	14	1146		120
8	1	51	9			695
9	3	73.8	18	998	1423	652
10	2	90.8	8	1486		30
11	1	73.7	6			313
12	3	96.4	12	1132	1556	384
13	2	50.1	6	1012		326
14	2	94.5	12	1348		618
15	1	72.8	7			752



A D T

Long Pulse Radar Test Signal

Test Signal Name: LP_Signal_09

Bursts in Trial: 16

Burst	Number of Pulses	Pulse Width (µsec)	Chirp Width (MHz)	Pulse 1-to-2 Spacing (µsec)	Pulse 2-to-3 Spacing (µsec)	Start Location Within Interval (msec)
1	3	89.9	8	1223	1312	112
2	3	92.1	6	1852	1536	211
3	1	97	20			548
4	2	53.6	19	1440		556
5	2	78.1	20	1740		115
6	2	68.8	8	1704		737
7	2	55	8	1135		269
8	1	80.3	14			399
9	2	64.6	10	1344		54
10	2	93.7	19	1106		615
11	2	85.2	5	989		553
12	2	50.4	20	1619		723
13	3	66.1	8	1212	974	692
14	1	67.6	17			253
15	1	57	12			733
16	1	82.8	15			487

Long Pulse Radar Test Signal

Test Signal Name: LP_Signal_10

Bursts in Trial: 17

Burst	Number of Pulses	Pulse Width (µsec)	Chirp Width (MHz)	Pulse 1-to-2 Spacing (µsec)	Pulse 2-to-3 Spacing (µsec)	Start Location Within Interval (msec)
1	2	95	5	1373		448
2	2	74.3	12	1242		644
3	2	57	19	1693		623
4	1	63	15			16
5	3	78.2	9	996	1807	64
6	1	65.4	18			318
7	2	63.6	18	1631		57
8	3	77.4	13	1596	1822	674
9	1	83.9	14			517
10	2	96.4	19	1237		197
11	3	57.4	5	1196	1555	139
12	2	94.2	5	1564		99
13	3	50	5	1923	1273	484
14	3	85.7	17	953	1606	356
15	2	70.3	11	1248		516
16	1	83.4	12			468
17	1	73.4	9			298



A D T

Long Pulse Radar Test Signal

Test Signal Name: LP_Signal_11

Bursts in Trial: 18

Burst	Number of Pulses	Pulse Width (µsec)	Chirp Width (MHz)	Pulse 1-to-2 Spacing (µsec)	Pulse 2-to-3 Spacing (µsec)	Start Location Within Interval (msec)
1	3	93.5	14	1182	960	602
2	1	55.6	19			361
3	2	55.5	6	946		425
4	2	69.5	13	1892		72
5	3	74.3	7	1550	1667	601
6	2	72.3	5	1783		133
7	2	61.2	15	1704		546
8	3	91.2	12	1462	1378	304
9	2	96.8	19	1766		56
10	2	89.5	8	1458		442
11	1	71.1	6			399
12	3	67.9	13	1541	1133	306
13	2	62.8	6	994		464
14	2	78	11	1304		163
15	1	54.3	11			305
16	1	52.1	20			199
17	1	74.9	18			397
18	2	91.9	14	1645		458

Long Pulse Radar Test Signal

Test Signal Name: LP_Signal_12

Bursts in Trial: 19

Burst	Number of Pulses	Pulse Width (µsec)	Chirp Width (MHz)	Pulse 1-to-2 Spacing (µsec)	Pulse 2-to-3 Spacing (µsec)	Start Location Within Interval (msec)
1	2	65.6	7	984		319
2	2	63.9	17	1137		462
3	2	52.9	17	1318		483
4	3	58.3	9	1901	1223	532
5	3	60.7	19	1891	1289	290
6	2	86.3	12	930		341
7	2	59	14	1076		401
8	2	95.8	18	1214		243
9	2	91	13	1788		437
10	2	97.5	17	1226		251
11	3	62	12	1066	1261	46
12	2	52.5	9	1424		286
13	3	87.5	8	1789	1822	463
14	2	63.5	15	1852		38
15	2	59.9	13	1618		444
16	1	91.4	13			423
17	1	62.3	10			266
18	2	77.7	10	1489		545
19	2	70.8	10	930		343



A D T

Long Pulse Radar Test Signal

Test Signal Name: LP_Signal_13

Bursts in Trial: 20

Burst	Number of Pulses	Pulse Width (µsec)	Chirp Width (MHz)	Pulse 1-to-2 Spacing (µsec)	Pulse 2-to-3 Spacing (µsec)	Start Location Within Interval (msec)
1	2	85.7	6	1066		429
2	3	69.6	13	1514	1504	391
3	3	80.9	9	1866	1839	62
4	1	73.8	14			161
5	1	62.3	12			359
6	1	74.6	18			221
7	2	58.3	7	1109		513
8	1	67.8	12			509
9	2	94.2	12	1753		343
10	2	83.6	9	1588		407
11	1	87.9	19			108
12	1	99.3	7			517
13	3	91.4	7	912	1742	418
14	1	79.1	8			309
15	3	84.1	18	1572	1521	378
16	2	87.4	7	1474		188
17	1	51.6	20			480
18	2	66.1	10	1639		135
19	3	63.4	9	1372	1349	26
20	3	92	10	1885	1853	384

Long Pulse Radar Test Signal

Test Signal Name: LP_Signal_14

Bursts in Trial: 8

Burst	Number of Pulses	Pulse Width (µsec)	Chirp Width (MHz)	Pulse 1-to-2 Spacing (µsec)	Pulse 2-to-3 Spacing (µsec)	Start Location Within Interval (msec)
1	2	72	20	1054		1059
2	2	64	8	1909		117
3	2	93	14	1276		1131
4	2	72.4	19	1673		458
5	3	95.2	12	1802	1413	796
6	3	74.2	14	1829	1192	984
7	3	79.8	6	1009	1424	778
8	2	63.9	8	963		483



A D T

Long Pulse Radar Test Signal

Test Signal Name: LP_Signal_15

Bursts in Trial: 9

Burst	Number of Pulses	Pulse Width (µsec)	Chirp Width (MHz)	Pulse 1-to-2 Spacing (µsec)	Pulse 2-to-3 Spacing (µsec)	Start Location Within Interval (msec)
1	2	72.9	11	1448		196
2	2	92.7	9	1327		512
3	2	87.4	7	1454		766
4	3	76.6	9	1384	1359	1278
5	2	53.1	15	1053		96
6	3	53.5	8	1693	1727	1181
7	2	70.7	18	1762		880
8	2	92.5	10	1592		317
9	2	84.5	12	1861		1076

Long Pulse Radar Test Signal

Test Signal Name: LP_Signal_16

Bursts in Trial: 10

Burst	Number of Pulses	Pulse Width (µsec)	Chirp Width (MHz)	Pulse 1-to-2 Spacing (µsec)	Pulse 2-to-3 Spacing (µsec)	Start Location Within Interval (msec)
1	2	80.6	19	1471		89
2	3	61.8	10	1310	1789	1176
3	2	64.1	20	1236		795
4	2	77.1	20	1378		797
5	3	91.4	20	1886	1004	408
6	2	63.1	7	1271		960
7	2	59.8	18	1667		791
8	3	90.8	18	1628	916	997
9	2	82.8	10	1049		826
10	3	80.3	19	1383	1422	74

Long Pulse Radar Test Signal

Test Signal Name: LP_Signal_17

Bursts in Trial: 11

Burst	Number of Pulses	Pulse Width (µsec)	Chirp Width (MHz)	Pulse 1-to-2 Spacing (µsec)	Pulse 2-to-3 Spacing (µsec)	Start Location Within Interval (msec)
1	1	77.5	6			80
2	2	92.8	18	1840		145
3	2	63.1	7	1832		521
4	2	75.4	13	1251		146
5	3	86.8	19	1007	1315	354
6	1	83.4	7			277
7	2	86.4	17	1394		778
8	1	65.4	12			501
9	1	51.5	18			509
10	1	90.9	6			356
11	2	90.5	18	1388		584



A D T

Long Pulse Radar Test Signal

Test Signal Name: LP_Signal_18

Bursts in Trial: 12

Burst	Number of Pulses	Pulse Width (µsec)	Chirp Width (MHz)	Pulse 1-to-2 Spacing (µsec)	Pulse 2-to-3 Spacing (µsec)	Start Location Within Interval (msec)
1	1	73.3	20			417
2	2	99.5	15	1797		439
3	2	76.5	7	1642		496
4	2	78.9	10	1520		370
5	3	54.4	17	984	1009	211
6	2	90.5	12	1137		948
7	3	94.3	9	1018	1312	410
8	1	97.7	10			225
9	2	74.7	18	1275		461
10	1	65.9	11			638
11	2	74.3	13	1769		381
12	2	83.4	9	1775		119

Long Pulse Radar Test Signal

Test Signal Name: LP_Signal_19

Bursts in Trial: 14

Burst	Number of Pulses	Pulse Width (µsec)	Chirp Width (MHz)	Pulse 1-to-2 Spacing (µsec)	Pulse 2-to-3 Spacing (µsec)	Start Location Within Interval (msec)
1	1	95.7	12			398
2	3	53	6	1541	1891	408
3	3	92.4	8	996	1454	428
4	1	58.4	17			322
5	2	97.9	5	1514		225
6	3	72	9	1813	1018	501
7	1	77.1	20			216
8	2	65.6	15	1328		275
9	3	84.9	8	1788	1254	407
10	1	79	20			78
11	3	89.1	13	989	1365	638
12	3	51.4	10	1716	1055	522
13	2	75	6	1768		627
14	2	88.6	11	1041		473



A D T

Long Pulse Radar Test Signal

Test Signal Name: LP_Signal_20

Bursts in Trial: 15

Burst	Number of Pulses	Pulse Width (μsec)	Chirp Width (MHz)	Pulse 1-to-2 Spacing (μsec)	Pulse 2-to-3 Spacing (μsec)	Start Location Within Interval (msec)
1	3	96.2	6	1240	1650	544
2	1	89	19			278
3	1	91.2	17			418
4	3	86.2	8	1374	1021	706
5	2	88.6	20	1668		570
6	3	57.6	8	1370	978	424
7	2	51	18	1208		102
8	3	86.9	6	1392	1661	9
9	3	62.2	15	1023	1727	770
10	3	82.5	5	965	1332	596
11	2	94.1	18	1243		282
12	2	55.7	5	1167		775
13	3	81.3	7	1313	1439	586
14	1	64.3	13			333
15	2	88.9	18	956		647

Long Pulse Radar Test Signal

Test Signal Name: LP_Signal_21

Bursts in Trial: 16

Burst	Number of Pulses	Pulse Width (μsec)	Chirp Width (MHz)	Pulse 1-to-2 Spacing (μsec)	Pulse 2-to-3 Spacing (μsec)	Start Location Within Interval (msec)
1	2	64.5	11	1472		80
2	1	69.7	11			207
3	2	85	8	1358		544
4	2	88.6	5	1674		501
5	2	88.7	14	1459		76
6	3	90.1	17	1896	1753	189
7	2	74.2	14	1108		546
8	1	95.1	19			437
9	2	52.5	13	999		360
10	2	53.8	18	1873		621
11	2	53.6	15	1105		531
12	3	52	6	1587	1562	175
13	3	83	8	1030	1018	689
14	1	77	13			217
15	2	69.9	14	1904		282
16	2	76.9	13	1684		608



A D T

Long Pulse Radar Test Signal
Test Signal Name: LP_Signal_22

Bursts in Trial: 17

Burst	Number of Pulses	Pulse Width (µsec)	Chirp Width (MHz)	Pulse 1-to-2 Spacing (µsec)	Pulse 2-to-3 Spacing (µsec)	Start Location Within Interval (msec)
1	1	71.7	18			222
2	2	57	18	1373		330
3	2	67.6	15	1193		183
4	3	81	14	1041	1183	185
5	2	58.1	20	1913		182
6	1	98.8	6			113
7	1	60	14			195
8	3	98.6	15	978	1411	102
9	1	67.9	10			67
10	1	85.4	20			490
11	2	67.6	10	1683		75
12	1	55.6	12			35
13	3	63	5	1663	938	539
14	2	73.9	8	1567		542
15	2	86.8	20	1040		307
16	2	96.7	18	994		294
17	3	89	9	1790	1144	554

Long Pulse Radar Test Signal
Test Signal Name: LP_Signal_23

Bursts in Trial: 18

Burst	Number of Pulses	Pulse Width (µsec)	Chirp Width (MHz)	Pulse 1-to-2 Spacing (µsec)	Pulse 2-to-3 Spacing (µsec)	Start Location Within Interval (msec)
1	2	73.9	20	1691		532
2	2	58.3	18	1689		419
3	3	68.9	7	1540	943	304
4	2	51.5	13	1647		368
5	3	68.6	13	1699	960	593
6	2	81.1	15	1805		264
7	3	87.6	17	1099	1473	466
8	2	81	17	1385		213
9	3	53.5	13	1069	1670	458
10	2	67.8	11	1790		392
11	2	59.3	11	1935		206
12	2	67.9	19	1780		163
13	1	52.8	15			570
14	1	78.9	6			314
15	3	92.9	6	1079	952	23
16	2	54.2	7	1494		457
17	2	86.9	9	933		87
18	3	72.4	7	1607	1625	506



A D T

Long Pulse Radar Test Signal
Test Signal Name: LP_Signal_24

Bursts in Trial: 19

Burst	Number of Pulses	Pulse Width (µsec)	Chirp Width (MHz)	Pulse 1-to-2 Spacing (µsec)	Pulse 2-to-3 Spacing (µsec)	Start Location Within Interval (msec)
1	3	70.1	5	1231	1505	5
2	2	95.3	6	1510		581
3	2	76.3	13	1488		415
4	3	97.8	9	996	1065	616
5	1	75.7	13			565
6	1	89.7	12			476
7	3	75.7	5	1197	1051	36
8	2	72.8	10	1719		158
9	2	94.1	13	1116		301
10	2	69.2	10	1579		110
11	2	86	13	1558		570
12	1	63.5	13			469
13	3	57.2	19	1439	1771	304
14	3	95.2	5	980	1333	294
15	1	95.6	10			114
16	2	70.8	7	1509		208
17	1	59.7	17			194
18	3	56	19	1362	993	506
19	2	70.7	13	1877		212

Long Pulse Radar Test Signal
Test Signal Name: LP_Signal_25

Bursts in Trial: 20

Burst	Number of Pulses	Pulse Width (µsec)	Chirp Width (MHz)	Pulse 1-to-2 Spacing (µsec)	Pulse 2-to-3 Spacing (µsec)	Start Location Within Interval (msec)
1	3	65.8	19	1785	1491	37
2	1	52.9	14			275
3	2	81.6	19	1439		219
4	1	52.9	20			324
5	1	95.3	15			342
6	3	98.3	9	963	1372	548
7	2	67.8	20	1080		452
8	1	88.3	8			35
9	2	94.3	15	1767		76
10	2	88.9	14	974		376
11	2	89.2	10	1393		38
12	2	91.5	13	1117		501
13	1	58.5	9			227
14	1	89.7	19			36
15	3	99.9	13	1613	1463	535
16	1	72.1	8			167
17	2	75.5	5	1341		522
18	1	57.3	12			63
19	3	93.9	13	1888	1183	21
20	2	97.9	18	1752		359



A D T

Long Pulse Radar Test Signal						
Test Signal Name: LP_Signal_26						
Bursts in Trial: 8						
Burst	Number of Pulses	Pulse Width (μsec)	Chirp Width (MHz)	Pulse 1-to-2 Spacing (μsec)	Pulse 2-to-3 Spacing (μsec)	Start Location Within Interval (msec)
1	1	52.8	20			3
2	1	68.1	7			1296
3	2	65.1	6	1207		1272
4	2	56.7	8	1034		83
5	2	98.2	7	1405		618
6	1	54.1	19			929
7	2	83.4	14	1822		564
8	2	58.3	12	1269		897

Long Pulse Radar Test Signal						
Test Signal Name: LP_Signal_27						
Bursts in Trial: 9						
Burst	Number of Pulses	Pulse Width (μsec)	Chirp Width (MHz)	Pulse 1-to-2 Spacing (μsec)	Pulse 2-to-3 Spacing (μsec)	Start Location Within Interval (msec)
1	3	95.6	5	1081	1377	39
2	2	69.3	19	1334		791
3	1	92.3	14			488
4	1	54.1	19			315
5	3	90.9	8	920	1382	416
6	2	73.9	13	1406		1088
7	1	83.7	19			785
8	2	75.2	7	1050		1006
9	2	77.3	14	1066		183

Long Pulse Radar Test Signal						
Test Signal Name: LP_Signal_28						
Bursts in Trial: 10						
Burst	Number of Pulses	Pulse Width (μsec)	Chirp Width (MHz)	Pulse 1-to-2 Spacing (μsec)	Pulse 2-to-3 Spacing (μsec)	Start Location Within Interval (msec)
1	2	76.2	15	1260		428
2	2	81.3	11	926		542
3	1	70.2	20			543
4	2	87.3	11	1881		1076
5	1	56.5	8			748
6	2	94.8	11	1029		687
7	1	62.1	13			302
8	1	76.2	20			1122
9	2	95.3	9	1157		1083
10	1	59	13			827



A D T

Long Pulse Radar Test Signal

Test Signal Name: LP_Signal_29

Bursts in Trial: 11

Burst	Number of Pulses	Pulse Width (μsec)	Chirp Width (MHz)	Pulse 1-to-2 Spacing (μsec)	Pulse 2-to-3 Spacing (μsec)	Start Location Within Interval (msec)
1	1	61.5	7			462
2	2	62.2	20	1061		1002
3	2	64	11	1554		604
4	2	87.2	12	1168		714
5	2	51.7	11	1059		1081
6	2	75.9	8	1165		831
7	2	52.8	10	1792		772
8	1	67	9			604
9	2	50.1	6	1462		115
10	2	68.8	20	1053		176
11	2	96.7	20	1139		959

Long Pulse Radar Test Signal

Test Signal Name: LP_Signal_30

Bursts in Trial: 12

Burst	Number of Pulses	Pulse Width (μsec)	Chirp Width (MHz)	Pulse 1-to-2 Spacing (μsec)	Pulse 2-to-3 Spacing (μsec)	Start Location Within Interval (msec)
1	1	69.2	7			175
2	2	70.8	10	1821		539
3	2	50	13	1298		140
4	2	61.1	13	1197		496
5	1	55.4	17			544
6	2	81.8	12	918		663
7	2	63.4	15	1138		123
8	2	57.6	13	1686		389
9	2	91.4	17	1711		885
10	3	76.7	6	1716	1557	487
11	3	90.2	8	1606	1188	5
12	1	75.1	13			634



A D T

B.2 The Frequency Hopping Radar pattern

Hopping Frequency Sequence Name: HOP_FREQ_SEQ_01							
SEQ#	Frequency (Hz)	SEQ#	Frequency (Hz)	SEQ#	Frequency (Hz)	SEQ#	Frequency (Hz)
1	5.538G	2	5.655G	3	5.455G	4	5.632G
5	5.724G	6	5.435G	7	5.408G	8	5.407G
9	5.544G	10	5.349G	11	5.604G	12	5.405G
13	5.325G	14	5.419G	15	5.666G	16	5.338G
17	5.659G	18	5.677G	19	5.506G	20	5.702G
21	5.468G	22	5.481G	23	5.722G	24	5.456G
25	5.356G	26	5.298G	27	5.692G	28	5.351G
29	5.265G	30	5.709G	31	5.365G	32	5.660G
33	5.719G	34	5.710G	35	5.563G	36	5.428G
37	5.478G	38	5.570G	39	5.638G	40	5.513G
41	5.527G	42	5.404G	43	5.504G	44	5.691G
45	5.394G	46	5.716G	47	5.548G	48	5.596G
49	5.350G	50	5.492G	51	5.346G	52	5.678G
53	5.429G	54	5.552G	55	5.334G	56	5.608G
57	5.359G	58	5.556G	59	5.474G	60	5.406G
61	5.516G	62	5.715G	63	5.316G	64	5.627G
65	5.327G	66	5.502G	67	5.389G	68	5.685G
69	5.353G	70	5.294G	71	5.572G	72	5.392G
73	5.526G	74	5.347G	75	5.679G	76	5.447G
77	5.324G	78	5.449G	79	5.510G	80	5.461G
81	5.674G	82	5.454G	83	5.434G	84	5.414G
85	5.589G	86	5.561G	87	5.391G	88	5.482G
89	5.684G	90	5.315G	91	5.580G	92	5.698G
93	5.656G	94	5.499G	95	5.579G	96	5.635G
97	5.581G	98	5.330G	99	5.551G	100	5.396G



A D T

Hopping Frequency Sequence Name: HOP_FREQ_SEQ_02							
SEQ#	Frequency (Hz)	SEQ#	Frequency (Hz)	SEQ#	Frequency (Hz)	SEQ#	Frequency (Hz)
1	5.530G	2	5.313G	3	5.473G	4	5.406G
5	5.631G	6	5.474G	7	5.553G	8	5.583G
9	5.304G	10	5.601G	11	5.427G	12	5.455G
13	5.323G	14	5.444G	15	5.690G	16	5.383G
17	5.647G	18	5.551G	19	5.351G	20	5.693G
21	5.609G	22	5.711G	23	5.700G	24	5.489G
25	5.287G	26	5.358G	27	5.573G	28	5.408G
29	5.724G	30	5.680G	31	5.513G	32	5.640G
33	5.476G	34	5.498G	35	5.614G	36	5.396G
37	5.634G	38	5.603G	39	5.448G	40	5.581G
41	5.438G	42	5.401G	43	5.566G	44	5.475G
45	5.660G	46	5.708G	47	5.645G	48	5.525G
49	5.327G	50	5.488G	51	5.484G	52	5.405G
53	5.302G	54	5.578G	55	5.662G	56	5.589G
57	5.648G	58	5.353G	59	5.558G	60	5.613G
61	5.612G	62	5.570G	63	5.494G	64	5.586G
65	5.331G	66	5.636G	67	5.677G	68	5.657G
69	5.387G	70	5.650G	71	5.564G	72	5.571G
73	5.284G	74	5.679G	75	5.479G	76	5.506G
77	5.716G	78	5.458G	79	5.471G	80	5.707G
81	5.294G	82	5.434G	83	5.352G	84	5.559G
85	5.433G	86	5.412G	87	5.328G	88	5.429G
89	5.715G	90	5.667G	91	5.656G	92	5.426G
93	5.336G	94	5.441G	95	5.557G	96	5.517G
97	5.696G	98	5.591G	99	5.464G	100	5.544G



A D T

Hopping Frequency Sequence Name: HOP_FREQ_SEQ_03							
SEQ#	Frequency (Hz)	SEQ#	Frequency (Hz)	SEQ#	Frequency (Hz)	SEQ#	Frequency (Hz)
1	5.693G	2	5.639G	3	5.515G	4	5.407G
5	5.283G	6	5.327G	7	5.521G	8	5.330G
9	5.586G	10	5.423G	11	5.486G	12	5.707G
13	5.569G	14	5.425G	15	5.527G	16	5.419G
17	5.475G	18	5.308G	19	5.333G	20	5.614G
21	5.519G	22	5.390G	23	5.671G	24	5.575G
25	5.544G	26	5.427G	27	5.534G	28	5.537G
29	5.337G	30	5.478G	31	5.654G	32	5.359G
33	5.546G	34	5.723G	35	5.685G	36	5.414G
37	5.697G	38	5.652G	39	5.485G	40	5.646G
41	5.587G	42	5.433G	43	5.357G	44	5.492G
45	5.647G	46	5.704G	47	5.500G	48	5.397G
49	5.452G	50	5.576G	51	5.339G	52	5.341G
53	5.628G	54	5.350G	55	5.599G	56	5.608G
57	5.556G	58	5.441G	59	5.376G	60	5.714G
61	5.354G	62	5.678G	63	5.496G	64	5.462G
65	5.398G	66	5.600G	67	5.426G	68	5.703G
69	5.531G	70	5.502G	71	5.606G	72	5.434G
73	5.610G	74	5.633G	75	5.725G	76	5.432G
77	5.467G	78	5.601G	79	5.641G	80	5.597G
81	5.408G	82	5.699G	83	5.594G	84	5.411G
85	5.565G	86	5.691G	87	5.405G	88	5.675G
89	5.281G	90	5.689G	91	5.660G	92	5.592G
93	5.702G	94	5.651G	95	5.626G	96	5.445G
97	5.612G	98	5.525G	99	5.598G	100	5.551G



A D T

Hopping Frequency Sequence Name: HOP_FREQ_SEQ_04							
SEQ#	Frequency (Hz)	SEQ#	Frequency (Hz)	SEQ#	Frequency (Hz)	SEQ#	Frequency (Hz)
1	5.425G	2	5.484G	3	5.581G	4	5.509G
5	5.452G	6	5.676G	7	5.611G	8	5.584G
9	5.271G	10	5.600G	11	5.421G	12	5.439G
13	5.364G	14	5.513G	15	5.489G	16	5.532G
17	5.283G	18	5.289G	19	5.466G	20	5.693G
21	5.471G	22	5.383G	23	5.631G	24	5.523G
25	5.447G	26	5.500G	27	5.479G	28	5.459G
29	5.680G	30	5.440G	31	5.573G	32	5.526G
33	5.632G	34	5.580G	35	5.448G	36	5.409G
37	5.645G	38	5.534G	39	5.442G	40	5.515G
41	5.464G	42	5.689G	43	5.543G	44	5.531G
45	5.390G	46	5.567G	47	5.715G	48	5.451G
49	5.550G	50	5.592G	51	5.477G	52	5.491G
53	5.660G	54	5.555G	55	5.702G	56	5.596G
57	5.432G	58	5.381G	59	5.662G	60	5.713G
61	5.438G	62	5.346G	63	5.358G	64	5.593G
65	5.706G	66	5.687G	67	5.482G	68	5.621G
69	5.360G	70	5.354G	71	5.552G	72	5.437G
73	5.572G	74	5.638G	75	5.478G	76	5.343G
77	5.591G	78	5.307G	79	5.605G	80	5.659G
81	5.538G	82	5.717G	83	5.554G	84	5.469G
85	5.320G	86	5.725G	87	5.665G	88	5.653G
89	5.603G	90	5.406G	91	5.454G	92	5.551G
93	5.574G	94	5.564G	95	5.350G	96	5.487G
97	5.684G	98	5.651G	99	5.635G	100	5.577G



A D T

Hopping Frequency Sequence Name: HOP_FREQ_SEQ_05							
SEQ#	Frequency (Hz)	SEQ#	Frequency (Hz)	SEQ#	Frequency (Hz)	SEQ#	Frequency (Hz)
1	5.371G	2	5.701G	3	5.683G	4	5.497G
5	5.269G	6	5.688G	7	5.403G	8	5.715G
9	5.393G	10	5.351G	11	5.648G	12	5.480G
13	5.679G	14	5.693G	15	5.468G	16	5.640G
17	5.642G	18	5.647G	19	5.435G	20	5.503G
21	5.402G	22	5.636G	23	5.335G	24	5.706G
25	5.409G	26	5.549G	27	5.455G	28	5.653G
29	5.374G	30	5.628G	31	5.430G	32	5.561G
33	5.540G	34	5.535G	35	5.331G	36	5.354G
37	5.318G	38	5.546G	39	5.624G	40	5.481G
41	5.697G	42	5.630G	43	5.364G	44	5.722G
45	5.398G	46	5.299G	47	5.394G	48	5.665G
49	5.675G	50	5.617G	51	5.682G	52	5.723G
53	5.426G	54	5.681G	55	5.408G	56	5.638G
57	5.284G	58	5.623G	59	5.395G	60	5.343G
61	5.657G	62	5.338G	63	5.644G	64	5.672G
65	5.531G	66	5.345G	67	5.488G	68	5.658G
69	5.544G	70	5.382G	71	5.493G	72	5.578G
73	5.534G	74	5.380G	75	5.588G	76	5.607G
77	5.615G	78	5.692G	79	5.498G	80	5.637G
81	5.551G	82	5.602G	83	5.406G	84	5.539G
85	5.669G	86	5.384G	87	5.464G	88	5.708G
89	5.527G	90	5.429G	91	5.432G	92	5.724G
93	5.489G	94	5.472G	95	5.556G	96	5.673G
97	5.349G	98	5.584G	99	5.678G	100	5.483G



A D T

Hopping Frequency Sequence Name: HOP_FREQ_SEQ_06							
SEQ#	Frequency (Hz)	SEQ#	Frequency (Hz)	SEQ#	Frequency (Hz)	SEQ#	Frequency (Hz)
1	5.563G	2	5.358G	3	5.443G	4	5.496G
5	5.463G	6	5.533G	7	5.372G	8	5.491G
9	5.653G	10	5.612G	11	5.337G	12	5.610G
13	5.633G	14	5.380G	15	5.715G	16	5.595G
17	5.382G	18	5.343G	19	5.457G	20	5.539G
21	5.330G	22	5.655G	23	5.416G	24	5.492G
25	5.397G	26	5.449G	27	5.311G	28	5.629G
29	5.258G	30	5.696G	31	5.574G	32	5.632G
33	5.487G	34	5.346G	35	5.455G	36	5.371G
37	5.458G	38	5.658G	39	5.399G	40	5.485G
41	5.452G	42	5.447G	43	5.405G	44	5.411G
45	5.285G	46	5.562G	47	5.712G	48	5.520G
49	5.618G	50	5.364G	51	5.360G	52	5.445G
53	5.603G	54	5.300G	55	5.720G	56	5.453G
57	5.368G	58	5.298G	59	5.702G	60	5.528G
61	5.451G	62	5.619G	63	5.651G	64	5.705G
65	5.565G	66	5.376G	67	5.607G	68	5.624G
69	5.316G	70	5.648G	71	5.625G	72	5.686G
73	5.529G	74	5.356G	75	5.598G	76	5.667G
77	5.650G	78	5.467G	79	5.505G	80	5.643G
81	5.336G	82	5.508G	83	5.634G	84	5.512G
85	5.361G	86	5.394G	87	5.630G	88	5.719G
89	5.573G	90	5.462G	91	5.466G	92	5.559G
93	5.567G	94	5.456G	95	5.501G	96	5.490G
97	5.677G	98	5.652G	99	5.419G	100	5.494G



A D T

Hopping Frequency Sequence Name: HOP_FREQ_SEQ_07							
SEQ#	Frequency (Hz)	SEQ#	Frequency (Hz)	SEQ#	Frequency (Hz)	SEQ#	Frequency (Hz)
1	5.495G	2	5.290G	3	5.484G	4	5.608G
5	5.368G	6	5.587G	7	5.657G	8	5.407G
9	5.482G	10	5.337G	11	5.724G	12	5.390G
13	5.519G	14	5.408G	15	5.437G	16	5.658G
17	5.598G	18	5.630G	19	5.334G	20	5.449G
21	5.476G	22	5.642G	23	5.656G	24	5.338G
25	5.650G	26	5.694G	27	5.537G	28	5.505G
29	5.547G	30	5.685G	31	5.610G	32	5.596G
33	5.562G	34	5.532G	35	5.322G	36	5.369G
37	5.515G	38	5.328G	39	5.351G	40	5.459G
41	5.561G	42	5.681G	43	5.385G	44	5.572G
45	5.682G	46	5.507G	47	5.663G	48	5.428G
49	5.695G	50	5.295G	51	5.715G	52	5.548G
53	5.414G	54	5.452G	55	5.371G	56	5.640G
57	5.522G	58	5.622G	59	5.577G	60	5.450G
61	5.604G	62	5.392G	63	5.316G	64	5.713G
65	5.526G	66	5.293G	67	5.595G	68	5.469G
69	5.569G	70	5.410G	71	5.688G	72	5.394G
73	5.496G	74	5.483G	75	5.509G	76	5.581G
77	5.645G	78	5.703G	79	5.592G	80	5.349G
81	5.393G	82	5.659G	83	5.370G	84	5.359G
85	5.660G	86	5.396G	87	5.709G	88	5.478G
89	5.472G	90	5.374G	91	5.473G	92	5.696G
93	5.457G	94	5.625G	95	5.440G	96	5.599G
97	5.406G	98	5.525G	99	5.531G	100	5.528G



A D T

Hopping Frequency Sequence Name: HOP_FREQ_SEQ_08							
SEQ#	Frequency (Hz)	SEQ#	Frequency (Hz)	SEQ#	Frequency (Hz)	SEQ#	Frequency (Hz)
1	5.651G	2	5.394G	3	5.437G	4	5.631G
5	5.458G	6	5.711G	7	5.649G	8	5.431G
9	5.615G	10	5.408G	11	5.679G	12	5.381G
13	5.569G	14	5.603G	15	5.339G	16	5.344G
17	5.412G	18	5.550G	19	5.493G	20	5.352G
21	5.278G	22	5.359G	23	5.380G	24	5.725G
25	5.660G	26	5.303G	27	5.551G	28	5.647G
29	5.712G	30	5.680G	31	5.673G	32	5.613G
33	5.623G	34	5.591G	35	5.334G	36	5.456G
37	5.661G	38	5.541G	39	5.383G	40	5.721G
41	5.501G	42	5.472G	43	5.364G	44	5.340G
45	5.413G	46	5.355G	47	5.418G	48	5.498G
49	5.292G	50	5.564G	51	5.513G	52	5.702G
53	5.454G	54	5.666G	55	5.633G	56	5.611G
57	5.365G	58	5.486G	59	5.371G	60	5.694G
61	5.313G	62	5.400G	63	5.317G	64	5.605G
65	5.641G	66	5.617G	67	5.478G	68	5.632G
69	5.409G	70	5.713G	71	5.421G	72	5.460G
73	5.336G	74	5.444G	75	5.537G	76	5.618G
77	5.622G	78	5.598G	79	5.674G	80	5.487G
81	5.318G	82	5.475G	83	5.589G	84	5.443G
85	5.471G	86	5.434G	87	5.565G	88	5.530G
89	5.536G	90	5.373G	91	5.566G	92	5.455G
93	5.465G	94	5.594G	95	5.502G	96	5.595G
97	5.452G	98	5.399G	99	5.600G	100	5.543G



A D T

Hopping Frequency Sequence Name: HOP_FREQ_SEQ_09							
SEQ#	Frequency (Hz)	SEQ#	Frequency (Hz)	SEQ#	Frequency (Hz)	SEQ#	Frequency (Hz)
1	5.449G	2	5.633G	3	5.324G	4	5.372G
5	5.696G	6	5.336G	7	5.363G	8	5.577G
9	5.607G	10	5.547G	11	5.518G	12	5.628G
13	5.256G	14	5.649G	15	5.491G	16	5.565G
17	5.545G	18	5.528G	19	5.483G	20	5.680G
21	5.433G	22	5.334G	23	5.305G	24	5.423G
25	5.397G	26	5.441G	27	5.344G	28	5.606G
29	5.466G	30	5.566G	31	5.632G	32	5.477G
33	5.725G	34	5.602G	35	5.489G	36	5.465G
37	5.610G	38	5.309G	39	5.662G	40	5.583G
41	5.558G	42	5.605G	43	5.707G	44	5.415G
45	5.586G	46	5.373G	47	5.354G	48	5.487G
49	5.389G	50	5.328G	51	5.556G	52	5.342G
53	5.667G	54	5.710G	55	5.502G	56	5.627G
57	5.426G	58	5.636G	59	5.508G	60	5.536G
61	5.390G	62	5.554G	63	5.323G	64	5.504G
65	5.267G	66	5.665G	67	5.668G	68	5.360G
69	5.625G	70	5.531G	71	5.440G	72	5.349G
73	5.322G	74	5.442G	75	5.358G	76	5.612G
77	5.611G	78	5.576G	79	5.719G	80	5.591G
81	5.313G	82	5.538G	83	5.460G	84	5.469G
85	5.362G	86	5.463G	87	5.400G	88	5.603G
89	5.617G	90	5.575G	91	5.395G	92	5.647G
93	5.613G	94	5.626G	95	5.717G	96	5.635G
97	5.335G	98	5.509G	99	5.451G	100	5.618G



A D T

Hopping Frequency Sequence Name: HOP_FREQ_SEQ_10							
SEQ#	Frequency (Hz)	SEQ#	Frequency (Hz)	SEQ#	Frequency (Hz)	SEQ#	Frequency (Hz)
1	5.693G	2	5.385G	3	5.407G	4	5.340G
5	5.683G	6	5.485G	7	5.451G	8	5.548G
9	5.550G	10	5.665G	11	5.376G	12	5.395G
13	5.342G	14	5.486G	15	5.516G	16	5.532G
17	5.609G	18	5.557G	19	5.717G	20	5.429G
21	5.517G	22	5.368G	23	5.440G	24	5.491G
25	5.508G	26	5.379G	27	5.723G	28	5.708G
29	5.543G	30	5.412G	31	5.377G	32	5.594G
33	5.570G	34	5.521G	35	5.313G	36	5.601G
37	5.299G	38	5.373G	39	5.661G	40	5.497G
41	5.280G	42	5.360G	43	5.384G	44	5.572G
45	5.478G	46	5.292G	47	5.545G	48	5.644G
49	5.463G	50	5.333G	51	5.430G	52	5.454G
53	5.654G	54	5.349G	55	5.427G	56	5.375G
57	5.580G	58	5.542G	59	5.437G	60	5.470G
61	5.579G	62	5.657G	63	5.554G	64	5.381G
65	5.316G	66	5.469G	67	5.627G	68	5.362G
69	5.539G	70	5.439G	71	5.387G	72	5.494G
73	5.691G	74	5.573G	75	5.404G	76	5.714G
77	5.687G	78	5.392G	79	5.716G	80	5.353G
81	5.686G	82	5.481G	83	5.510G	84	5.688G
85	5.682G	86	5.442G	87	5.459G	88	5.571G
89	5.371G	90	5.369G	91	5.664G	92	5.707G
93	5.721G	94	5.618G	95	5.327G	96	5.435G
97	5.655G	98	5.453G	99	5.567G	100	5.705G



A D T

Hopping Frequency Sequence Name: HOP_FREQ_SEQ_11							
SEQ#	Frequency (Hz)	SEQ#	Frequency (Hz)	SEQ#	Frequency (Hz)	SEQ#	Frequency (Hz)
1	5.264G	2	5.712G	3	5.351G	4	5.624G
5	5.491G	6	5.405G	7	5.562G	8	5.688G
9	5.673G	10	5.626G	11	5.683G	12	5.526G
13	5.695G	14	5.309G	15	5.470G	16	5.654G
17	5.495G	18	5.679G	19	5.404G	20	5.543G
21	5.415G	22	5.671G	23	5.553G	24	5.536G
25	5.346G	26	5.471G	27	5.510G	28	5.357G
29	5.580G	30	5.303G	31	5.623G	32	5.533G
33	5.282G	34	5.686G	35	5.618G	36	5.385G
37	5.286G	38	5.451G	39	5.458G	40	5.446G
41	5.677G	42	5.323G	43	5.364G	44	5.362G
45	5.387G	46	5.646G	47	5.649G	48	5.534G
49	5.428G	50	5.681G	51	5.565G	52	5.718G
53	5.725G	54	5.332G	55	5.439G	56	5.709G
57	5.308G	58	5.338G	59	5.442G	60	5.497G
61	5.464G	62	5.496G	63	5.563G	64	5.627G
65	5.304G	66	5.500G	67	5.537G	68	5.697G
69	5.587G	70	5.307G	71	5.485G	72	5.454G
73	5.354G	74	5.322G	75	5.568G	76	5.644G
77	5.678G	78	5.372G	79	5.406G	80	5.552G
81	5.527G	82	5.693G	83	5.705G	84	5.361G
85	5.423G	86	5.638G	87	5.493G	88	5.590G
89	5.517G	90	5.604G	91	5.333G	92	5.358G
93	5.311G	94	5.550G	95	5.397G	96	5.367G
97	5.408G	98	5.418G	99	5.720G	100	5.592G



A D T

Hopping Frequency Sequence Name: HOP_FREQ_SEQ_12							
SEQ#	Frequency (Hz)	SEQ#	Frequency (Hz)	SEQ#	Frequency (Hz)	SEQ#	Frequency (Hz)
1	5.597G	2	5.285G	3	5.665G	4	5.556G
5	5.358G	6	5.664G	7	5.613G	8	5.362G
9	5.721G	10	5.616G	11	5.699G	12	5.356G
13	5.705G	14	5.337G	15	5.697G	16	5.339G
17	5.533G	18	5.395G	19	5.443G	20	5.629G
21	5.462G	22	5.531G	23	5.364G	24	5.565G
25	5.277G	26	5.460G	27	5.411G	28	5.437G
29	5.477G	30	5.689G	31	5.345G	32	5.601G
33	5.328G	34	5.657G	35	5.350G	36	5.479G
37	5.298G	38	5.545G	39	5.659G	40	5.338G
41	5.551G	42	5.456G	43	5.611G	44	5.367G
45	5.557G	46	5.543G	47	5.514G	48	5.471G
49	5.403G	50	5.535G	51	5.323G	52	5.380G
53	5.555G	54	5.670G	55	5.577G	56	5.517G
57	5.270G	58	5.377G	59	5.582G	60	5.407G
61	5.702G	62	5.642G	63	5.416G	64	5.619G
65	5.553G	66	5.672G	67	5.703G	68	5.419G
69	5.644G	70	5.452G	71	5.571G	72	5.390G
73	5.526G	74	5.633G	75	5.423G	76	5.422G
77	5.497G	78	5.646G	79	5.534G	80	5.496G
81	5.379G	82	5.436G	83	5.520G	84	5.522G
85	5.499G	86	5.638G	87	5.394G	88	5.687G
89	5.604G	90	5.632G	91	5.599G	92	5.592G
93	5.386G	94	5.515G	95	5.692G	96	5.510G
97	5.446G	98	5.714G	99	5.676G	100	5.431G



A D T

Hopping Frequency Sequence Name: HOP_FREQ_SEQ_13							
SEQ#	Frequency (Hz)	SEQ#	Frequency (Hz)	SEQ#	Frequency (Hz)	SEQ#	Frequency (Hz)
1	5.660G	2	5.431G	3	5.533G	4	5.427G
5	5.484G	6	5.700G	7	5.307G	8	5.480G
9	5.292G	10	5.549G	11	5.408G	12	5.379G
13	5.545G	14	5.694G	15	5.641G	16	5.501G
17	5.710G	18	5.692G	19	5.574G	20	5.620G
21	5.467G	22	5.402G	23	5.482G	24	5.716G
25	5.722G	26	5.615G	27	5.580G	28	5.721G
29	5.666G	30	5.463G	31	5.448G	32	5.370G
33	5.460G	34	5.715G	35	5.469G	36	5.656G
37	5.419G	38	5.645G	39	5.367G	40	5.577G
41	5.306G	42	5.605G	43	5.391G	44	5.684G
45	5.269G	46	5.351G	47	5.422G	48	5.364G
49	5.444G	50	5.576G	51	5.446G	52	5.389G
53	5.679G	54	5.542G	55	5.668G	56	5.663G
57	5.396G	58	5.714G	59	5.449G	60	5.670G
61	5.319G	62	5.331G	63	5.424G	64	5.658G
65	5.362G	66	5.682G	67	5.506G	68	5.538G
69	5.461G	70	5.316G	71	5.627G	72	5.380G
73	5.420G	74	5.438G	75	5.369G	76	5.661G
77	5.381G	78	5.657G	79	5.387G	80	5.677G
81	5.348G	82	5.555G	83	5.562G	84	5.602G
85	5.723G	86	5.690G	87	5.497G	88	5.421G
89	5.623G	90	5.434G	91	5.354G	92	5.614G
93	5.561G	94	5.566G	95	5.697G	96	5.368G
97	5.386G	98	5.543G	99	5.437G	100	5.523G



A D T

Hopping Frequency Sequence Name: HOP_FREQ_SEQ_14							
SEQ#	Frequency (Hz)	SEQ#	Frequency (Hz)	SEQ#	Frequency (Hz)	SEQ#	Frequency (Hz)
1	5.507G	2	5.540G	3	5.689G	4	5.606G
5	5.268G	6	5.353G	7	5.454G	8	5.607G
9	5.492G	10	5.435G	11	5.400G	12	5.334G
13	5.724G	14	5.313G	15	5.369G	16	5.398G
17	5.455G	18	5.671G	19	5.349G	20	5.503G
21	5.284G	22	5.700G	23	5.670G	24	5.475G
25	5.356G	26	5.657G	27	5.526G	28	5.629G
29	5.666G	30	5.615G	31	5.708G	32	5.511G
33	5.304G	34	5.674G	35	5.645G	36	5.570G
37	5.403G	38	5.530G	39	5.487G	40	5.664G
41	5.533G	42	5.627G	43	5.651G	44	5.499G
45	5.333G	46	5.588G	47	5.604G	48	5.360G
49	5.274G	50	5.576G	51	5.423G	52	5.504G
53	5.421G	54	5.518G	55	5.667G	56	5.694G
57	5.715G	58	5.451G	59	5.326G	60	5.682G
61	5.685G	62	5.381G	63	5.695G	64	5.437G
65	5.569G	66	5.490G	67	5.393G	68	5.510G
69	5.295G	70	5.448G	71	5.373G	72	5.692G
73	5.450G	74	5.673G	75	5.354G	76	5.444G
77	5.406G	78	5.419G	79	5.617G	80	5.701G
81	5.392G	82	5.357G	83	5.552G	84	5.534G
85	5.638G	86	5.440G	87	5.686G	88	5.350G
89	5.723G	90	5.529G	91	5.712G	92	5.367G
93	5.341G	94	5.572G	95	5.447G	96	5.630G
97	5.586G	98	5.414G	99	5.329G	100	5.525G



A D T

Hopping Frequency Sequence Name: HOP_FREQ_SEQ_15							
SEQ#	Frequency (Hz)	SEQ#	Frequency (Hz)	SEQ#	Frequency (Hz)	SEQ#	Frequency (Hz)
1	5.704G	2	5.453G	3	5.538G	4	5.392G
5	5.257G	6	5.662G	7	5.560G	8	5.701G
9	5.290G	10	5.665G	11	5.707G	12	5.678G
13	5.497G	14	5.516G	15	5.372G	16	5.541G
17	5.337G	18	5.456G	19	5.388G	20	5.485G
21	5.270G	22	5.702G	23	5.563G	24	5.616G
25	5.583G	26	5.596G	27	5.501G	28	5.692G
29	5.433G	30	5.629G	31	5.367G	32	5.694G
33	5.304G	34	5.353G	35	5.633G	36	5.656G
37	5.573G	38	5.449G	39	5.365G	40	5.559G
41	5.632G	42	5.504G	43	5.708G	44	5.679G
45	5.467G	46	5.451G	47	5.366G	48	5.631G
49	5.322G	50	5.298G	51	5.519G	52	5.407G
53	5.635G	54	5.525G	55	5.484G	56	5.360G
57	5.610G	58	5.398G	59	5.574G	60	5.549G
61	5.581G	62	5.690G	63	5.499G	64	5.687G
65	5.293G	66	5.498G	67	5.531G	68	5.565G
69	5.278G	70	5.617G	71	5.639G	72	5.608G
73	5.470G	74	5.615G	75	5.620G	76	5.401G
77	5.333G	78	5.621G	79	5.359G	80	5.355G
81	5.331G	82	5.604G	83	5.634G	84	5.724G
85	5.646G	86	5.532G	87	5.625G	88	5.543G
89	5.394G	90	5.439G	91	5.488G	92	5.533G
93	5.603G	94	5.592G	95	5.598G	96	5.652G
97	5.500G	98	5.599G	99	5.472G	100	5.611G



A D T

Hopping Frequency Sequence Name: HOP_FREQ_SEQ_16							
SEQ#	Frequency (Hz)	SEQ#	Frequency (Hz)	SEQ#	Frequency (Hz)	SEQ#	Frequency (Hz)
1	5.686G	2	5.436G	3	5.564G	4	5.632G
5	5.435G	6	5.282G	7	5.597G	8	5.447G
9	5.645G	10	5.415G	11	5.469G	12	5.519G
13	5.457G	14	5.413G	15	5.642G	16	5.590G
17	5.378G	18	5.517G	19	5.344G	20	5.353G
21	5.363G	22	5.649G	23	5.380G	24	5.540G
25	5.352G	26	5.663G	27	5.497G	28	5.588G
29	5.658G	30	5.546G	31	5.310G	32	5.706G
33	5.449G	34	5.543G	35	5.418G	36	5.595G
37	5.296G	38	5.379G	39	5.697G	40	5.671G
41	5.262G	42	5.324G	43	5.718G	44	5.558G
45	5.421G	46	5.617G	47	5.524G	48	5.668G
49	5.587G	50	5.725G	51	5.648G	52	5.423G
53	5.466G	54	5.647G	55	5.573G	56	5.659G
57	5.520G	58	5.312G	59	5.585G	60	5.708G
61	5.450G	62	5.332G	63	5.432G	64	5.535G
65	5.389G	66	5.470G	67	5.337G	68	5.495G
69	5.420G	70	5.382G	71	5.410G	72	5.638G
73	5.612G	74	5.654G	75	5.611G	76	5.357G
77	5.586G	78	5.496G	79	5.521G	80	5.395G
81	5.270G	82	5.594G	83	5.709G	84	5.419G
85	5.651G	86	5.539G	87	5.398G	88	5.516G
89	5.548G	90	5.664G	91	5.335G	92	5.355G
93	5.428G	94	5.467G	95	5.401G	96	5.499G
97	5.278G	98	5.567G	99	5.636G	100	5.620G



A D T

Hopping Frequency Sequence Name: HOP_FREQ_SEQ_17							
SEQ#	Frequency (Hz)	SEQ#	Frequency (Hz)	SEQ#	Frequency (Hz)	SEQ#	Frequency (Hz)
1	5.528G	2	5.705G	3	5.608G	4	5.690G
5	5.491G	6	5.604G	7	5.558G	8	5.639G
9	5.290G	10	5.706G	11	5.504G	12	5.642G
13	5.510G	14	5.464G	15	5.401G	16	5.408G
17	5.395G	18	5.460G	19	5.419G	20	5.382G
21	5.258G	22	5.697G	23	5.474G	24	5.426G
25	5.447G	26	5.696G	27	5.552G	28	5.437G
29	5.478G	30	5.566G	31	5.362G	32	5.485G
33	5.266G	34	5.583G	35	5.455G	36	5.567G
37	5.560G	38	5.529G	39	5.405G	40	5.711G
41	5.369G	42	5.412G	43	5.431G	44	5.610G
45	5.586G	46	5.400G	47	5.628G	48	5.440G
49	5.433G	50	5.482G	51	5.589G	52	5.383G
53	5.489G	54	5.380G	55	5.614G	56	5.541G
57	5.349G	58	5.502G	59	5.357G	60	5.717G
61	5.335G	62	5.715G	63	5.484G	64	5.526G
65	5.693G	66	5.653G	67	5.339G	68	5.632G
69	5.534G	70	5.714G	71	5.629G	72	5.678G
73	5.525G	74	5.689G	75	5.389G	76	5.377G
77	5.679G	78	5.515G	79	5.643G	80	5.704G
81	5.331G	82	5.317G	83	5.415G	84	5.376G
85	5.387G	86	5.296G	87	5.650G	88	5.396G
89	5.289G	90	5.545G	91	5.406G	92	5.627G
93	5.716G	94	5.725G	95	5.681G	96	5.634G
97	5.350G	98	5.527G	99	5.446G	100	5.467G



A D T

Hopping Frequency Sequence Name: HOP_FREQ_SEQ_18							
SEQ#	Frequency (Hz)	SEQ#	Frequency (Hz)	SEQ#	Frequency (Hz)	SEQ#	Frequency (Hz)
1	5.632G	2	5.673G	3	5.563G	4	5.686G
5	5.725G	6	5.703G	7	5.534G	8	5.664G
9	5.701G	10	5.290G	11	5.584G	12	5.574G
13	5.338G	14	5.695G	15	5.427G	16	5.656G
17	5.395G	18	5.447G	19	5.323G	20	5.614G
21	5.567G	22	5.489G	23	5.306G	24	5.388G
25	5.552G	26	5.294G	27	5.637G	28	5.349G
29	5.720G	30	5.503G	31	5.437G	32	5.616G
33	5.499G	34	5.451G	35	5.592G	36	5.496G
37	5.491G	38	5.424G	39	5.576G	40	5.359G
41	5.646G	42	5.363G	43	5.387G	44	5.501G
45	5.650G	46	5.307G	47	5.353G	48	5.520G
49	5.536G	50	5.548G	51	5.318G	52	5.715G
53	5.484G	54	5.564G	55	5.613G	56	5.358G
57	5.615G	58	5.587G	59	5.602G	60	5.504G
61	5.635G	62	5.684G	63	5.560G	64	5.453G
65	5.439G	66	5.472G	67	5.505G	68	5.555G
69	5.680G	70	5.657G	71	5.497G	72	5.485G
73	5.633G	74	5.524G	75	5.528G	76	5.639G
77	5.557G	78	5.676G	79	5.455G	80	5.426G
81	5.473G	82	5.390G	83	5.675G	84	5.699G
85	5.636G	86	5.674G	87	5.384G	88	5.589G
89	5.585G	90	5.586G	91	5.526G	92	5.593G
93	5.515G	94	5.352G	95	5.374G	96	5.511G
97	5.570G	98	5.488G	99	5.644G	100	5.517G



A D T

Hopping Frequency Sequence Name: HOP_FREQ_SEQ_19							
SEQ#	Frequency (Hz)	SEQ#	Frequency (Hz)	SEQ#	Frequency (Hz)	SEQ#	Frequency (Hz)
1	5.430G	2	5.678G	3	5.387G	4	5.594G
5	5.404G	6	5.306G	7	5.451G	8	5.654G
9	5.487G	10	5.383G	11	5.355G	12	5.456G
13	5.263G	14	5.511G	15	5.388G	16	5.362G
17	5.579G	18	5.320G	19	5.535G	20	5.554G
21	5.547G	22	5.577G	23	5.596G	24	5.722G
25	5.537G	26	5.720G	27	5.536G	28	5.474G
29	5.520G	30	5.576G	31	5.684G	32	5.473G
33	5.524G	34	5.510G	35	5.496G	36	5.335G
37	5.633G	38	5.416G	39	5.573G	40	5.482G
41	5.389G	42	5.373G	43	5.326G	44	5.674G
45	5.578G	46	5.645G	47	5.597G	48	5.637G
49	5.461G	50	5.468G	51	5.360G	52	5.595G
53	5.380G	54	5.453G	55	5.400G	56	5.519G
57	5.458G	58	5.602G	59	5.399G	60	5.386G
61	5.695G	62	5.328G	63	5.589G	64	5.498G
65	5.514G	66	5.352G	67	5.626G	68	5.563G
69	5.681G	70	5.428G	71	5.346G	72	5.406G
73	5.679G	74	5.414G	75	5.437G	76	5.707G
77	5.361G	78	5.369G	79	5.627G	80	5.703G
81	5.499G	82	5.422G	83	5.425G	84	5.687G
85	5.371G	86	5.612G	87	5.395G	88	5.682G
89	5.609G	90	5.318G	91	5.459G	92	5.546G
93	5.299G	94	5.685G	95	5.556G	96	5.515G
97	5.624G	98	5.516G	99	5.588G	100	5.713G



A D T

Hopping Frequency Sequence Name: HOP_FREQ_SEQ_20							
SEQ#	Frequency (Hz)	SEQ#	Frequency (Hz)	SEQ#	Frequency (Hz)	SEQ#	Frequency (Hz)
1	5.373G	2	5.492G	3	5.424G	4	5.447G
5	5.490G	6	5.359G	7	5.584G	8	5.515G
9	5.535G	10	5.396G	11	5.659G	12	5.438G
13	5.697G	14	5.607G	15	5.349G	16	5.421G
17	5.456G	18	5.711G	19	5.709G	20	5.430G
21	5.366G	22	5.571G	23	5.699G	24	5.590G
25	5.384G	26	5.414G	27	5.387G	28	5.614G
29	5.303G	30	5.478G	31	5.319G	32	5.391G
33	5.692G	34	5.402G	35	5.710G	36	5.572G
37	5.467G	38	5.441G	39	5.586G	40	5.395G
41	5.431G	42	5.302G	43	5.591G	44	5.472G
45	5.558G	46	5.725G	47	5.463G	48	5.682G
49	5.690G	50	5.465G	51	5.322G	52	5.545G
53	5.637G	54	5.419G	55	5.377G	56	5.551G
57	5.680G	58	5.363G	59	5.542G	60	5.685G
61	5.290G	62	5.488G	63	5.375G	64	5.654G
65	5.557G	66	5.529G	67	5.565G	68	5.678G
69	5.500G	70	5.410G	71	5.516G	72	5.700G
73	5.593G	74	5.631G	75	5.401G	76	5.594G
77	5.274G	78	5.412G	79	5.604G	80	5.361G
81	5.640G	82	5.509G	83	5.347G	84	5.459G
85	5.550G	86	5.566G	87	5.360G	88	5.413G
89	5.451G	90	5.491G	91	5.328G	92	5.513G
93	5.667G	94	5.723G	95	5.352G	96	5.433G
97	5.469G	98	5.646G	99	5.473G	100	5.527G



A D T

Hopping Frequency Sequence Name: HOP_FREQ_SEQ_21							
SEQ#	Frequency (Hz)	SEQ#	Frequency (Hz)	SEQ#	Frequency (Hz)	SEQ#	Frequency (Hz)
1	5.489G	2	5.555G	3	5.406G	4	5.400G
5	5.291G	6	5.478G	7	5.349G	8	5.377G
9	5.505G	10	5.444G	11	5.617G	12	5.522G
13	5.518G	14	5.462G	15	5.397G	16	5.581G
17	5.577G	18	5.361G	19	5.379G	20	5.667G
21	5.475G	22	5.416G	23	5.650G	24	5.447G
25	5.450G	26	5.525G	27	5.610G	28	5.451G
29	5.512G	30	5.375G	31	5.494G	32	5.706G
33	5.668G	34	5.480G	35	5.609G	36	5.665G
37	5.558G	38	5.662G	39	5.334G	40	5.630G
41	5.672G	42	5.655G	43	5.686G	44	5.344G
45	5.357G	46	5.327G	47	5.643G	48	5.676G
49	5.424G	50	5.389G	51	5.486G	52	5.674G
53	5.718G	54	5.441G	55	5.439G	56	5.442G
57	5.720G	58	5.297G	59	5.325G	60	5.699G
61	5.532G	62	5.661G	63	5.434G	64	5.704G
65	5.433G	66	5.485G	67	5.495G	68	5.642G
69	5.421G	70	5.395G	71	5.548G	72	5.396G
73	5.455G	74	5.715G	75	5.463G	76	5.691G
77	5.278G	78	5.497G	79	5.353G	80	5.602G
81	5.464G	82	5.401G	83	5.473G	84	5.680G
85	5.303G	86	5.407G	87	5.385G	88	5.578G
89	5.571G	90	5.412G	91	5.600G	92	5.579G
93	5.312G	94	5.469G	95	5.582G	96	5.575G
97	5.697G	98	5.671G	99	5.468G	100	5.541G



A D T

Hopping Frequency Sequence Name: HOP_FREQ_SEQ_22							
SEQ#	Frequency (Hz)	SEQ#	Frequency (Hz)	SEQ#	Frequency (Hz)	SEQ#	Frequency (Hz)
1	5.718G	2	5.283G	3	5.648G	4	5.562G
5	5.603G	6	5.546G	7	5.474G	8	5.612G
9	5.520G	10	5.538G	11	5.516G	12	5.660G
13	5.379G	14	5.307G	15	5.572G	16	5.381G
17	5.337G	18	5.372G	19	5.672G	20	5.588G
21	5.384G	22	5.329G	23	5.511G	24	5.703G
25	5.551G	26	5.373G	27	5.380G	28	5.593G
29	5.509G	30	5.634G	31	5.712G	32	5.465G
33	5.591G	34	5.430G	35	5.357G	36	5.506G
37	5.567G	38	5.301G	39	5.364G	40	5.619G
41	5.290G	42	5.514G	43	5.441G	44	5.396G
45	5.689G	46	5.709G	47	5.455G	48	5.495G
49	5.631G	50	5.345G	51	5.467G	52	5.486G
53	5.530G	54	5.497G	55	5.358G	56	5.645G
57	5.279G	58	5.469G	59	5.686G	60	5.655G
61	5.602G	62	5.429G	63	5.376G	64	5.436G
65	5.443G	66	5.332G	67	5.333G	68	5.652G
69	5.479G	70	5.523G	71	5.466G	72	5.483G
73	5.605G	74	5.320G	75	5.503G	76	5.400G
77	5.431G	78	5.674G	79	5.476G	80	5.407G
81	5.449G	82	5.367G	83	5.577G	84	5.702G
85	5.715G	86	5.661G	87	5.545G	88	5.507G
89	5.428G	90	5.658G	91	5.327G	92	5.363G
93	5.710G	94	5.610G	95	5.549G	96	5.508G
97	5.440G	98	5.356G	99	5.542G	100	5.515G



A D T

Hopping Frequency Sequence Name: HOP_FREQ_SEQ_23							
SEQ#	Frequency (Hz)	SEQ#	Frequency (Hz)	SEQ#	Frequency (Hz)	SEQ#	Frequency (Hz)
1	5.390G	2	5.476G	3	5.627G	4	5.687G
5	5.455G	6	5.293G	7	5.539G	8	5.657G
9	5.525G	10	5.668G	11	5.723G	12	5.523G
13	5.325G	14	5.469G	15	5.582G	16	5.601G
17	5.650G	18	5.406G	19	5.446G	20	5.506G
21	5.673G	22	5.620G	23	5.535G	24	5.676G
25	5.512G	26	5.678G	27	5.543G	28	5.454G
29	5.626G	30	5.656G	31	5.327G	32	5.700G
33	5.342G	34	5.584G	35	5.320G	36	5.689G
37	5.721G	38	5.323G	39	5.493G	40	5.722G
41	5.597G	42	5.664G	43	5.565G	44	5.344G
45	5.720G	46	5.669G	47	5.530G	48	5.570G
49	5.401G	50	5.649G	51	5.363G	52	5.611G
53	5.628G	54	5.318G	55	5.609G	56	5.564G
57	5.665G	58	5.310G	59	5.698G	60	5.671G
61	5.319G	62	5.608G	63	5.339G	64	5.471G
65	5.537G	66	5.474G	67	5.470G	68	5.399G
69	5.459G	70	5.502G	71	5.699G	72	5.685G
73	5.335G	74	5.593G	75	5.322G	76	5.475G
77	5.386G	78	5.387G	79	5.423G	80	5.587G
81	5.507G	82	5.302G	83	5.340G	84	5.481G
85	5.551G	86	5.644G	87	5.404G	88	5.599G
89	5.463G	90	5.362G	91	5.606G	92	5.621G
93	5.349G	94	5.637G	95	5.696G	96	5.413G
97	5.505G	98	5.499G	99	5.538G	100	5.351G



A D T

Hopping Frequency Sequence Name: HOP_FREQ_SEQ_24							
SEQ#	Frequency (Hz)	SEQ#	Frequency (Hz)	SEQ#	Frequency (Hz)	SEQ#	Frequency (Hz)
1	5.349G	2	5.299G	3	5.352G	4	5.450G
5	5.262G	6	5.518G	7	5.564G	8	5.566G
9	5.586G	10	5.693G	11	5.663G	12	5.401G
13	5.452G	14	5.600G	15	5.713G	16	5.434G
17	5.269G	18	5.331G	19	5.403G	20	5.553G
21	5.412G	22	5.603G	23	5.540G	24	5.455G
25	5.669G	26	5.432G	27	5.596G	28	5.386G
29	5.520G	30	5.690G	31	5.641G	32	5.569G
33	5.443G	34	5.613G	35	5.530G	36	5.422G
37	5.644G	38	5.521G	39	5.705G	40	5.370G
41	5.449G	42	5.507G	43	5.356G	44	5.410G
45	5.399G	46	5.678G	47	5.688G	48	5.718G
49	5.640G	50	5.587G	51	5.590G	52	5.498G
53	5.581G	54	5.353G	55	5.717G	56	5.658G
57	5.495G	58	5.698G	59	5.620G	60	5.639G
61	5.409G	62	5.568G	63	5.341G	64	5.707G
65	5.684G	66	5.307G	67	5.704G	68	5.485G
69	5.330G	70	5.499G	71	5.394G	72	5.482G
73	5.671G	74	5.382G	75	5.668G	76	5.435G
77	5.484G	78	5.664G	79	5.522G	80	5.384G
81	5.682G	82	5.309G	83	5.357G	84	5.565G
85	5.324G	86	5.597G	87	5.647G	88	5.719G
89	5.651G	90	5.576G	91	5.502G	92	5.389G
93	5.497G	94	5.697G	95	5.694G	96	5.395G
97	5.368G	98	5.574G	99	5.492G	100	5.702G



A D T

Hopping Frequency Sequence Name: HOP_FREQ_SEQ_25							
SEQ#	Frequency (Hz)	SEQ#	Frequency (Hz)	SEQ#	Frequency (Hz)	SEQ#	Frequency (Hz)
1	5.689G	2	5.620G	3	5.691G	4	5.561G
5	5.256G	6	5.352G	7	5.581G	8	5.477G
9	5.635G	10	5.503G	11	5.562G	12	5.664G
13	5.254G	14	5.382G	15	5.556G	16	5.696G
17	5.712G	18	5.301G	19	5.423G	20	5.623G
21	5.336G	22	5.661G	23	5.680G	24	5.587G
25	5.279G	26	5.681G	27	5.408G	28	5.331G
29	5.272G	30	5.299G	31	5.706G	32	5.364G
33	5.534G	34	5.573G	35	5.325G	36	5.598G
37	5.309G	38	5.365G	39	5.504G	40	5.449G
41	5.532G	42	5.346G	43	5.667G	44	5.486G
45	5.349G	46	5.419G	47	5.652G	48	5.609G
49	5.411G	50	5.610G	51	5.397G	52	5.622G
53	5.266G	54	5.371G	55	5.579G	56	5.654G
57	5.462G	58	5.482G	59	5.502G	60	5.531G
61	5.666G	62	5.655G	63	5.376G	64	5.700G
65	5.497G	66	5.392G	67	5.693G	68	5.509G
69	5.286G	70	5.355G	71	5.433G	72	5.460G
73	5.338G	74	5.305G	75	5.572G	76	5.603G
77	5.388G	78	5.690G	79	5.546G	80	5.378G
81	5.508G	82	5.653G	83	5.431G	84	5.631G
85	5.553G	86	5.520G	87	5.436G	88	5.628G
89	5.490G	90	5.430G	91	5.381G	92	5.402G
93	5.389G	94	5.606G	95	5.633G	96	5.600G
97	5.357G	98	5.671G	99	5.640G	100	5.450G



A D T

Hopping Frequency Sequence Name: HOP_FREQ_SEQ_26							
SEQ#	Frequency (Hz)	SEQ#	Frequency (Hz)	SEQ#	Frequency (Hz)	SEQ#	Frequency (Hz)
1	5.669G	2	5.577G	3	5.652G	4	5.392G
5	5.470G	6	5.694G	7	5.653G	8	5.340G
9	5.355G	10	5.672G	11	5.473G	12	5.656G
13	5.274G	14	5.619G	15	5.610G	16	5.639G
17	5.666G	18	5.579G	19	5.474G	20	5.641G
21	5.560G	22	5.667G	23	5.519G	24	5.692G
25	5.643G	26	5.590G	27	5.494G	28	5.491G
29	5.273G	30	5.502G	31	5.405G	32	5.452G
33	5.598G	34	5.416G	35	5.390G	36	5.707G
37	5.447G	38	5.344G	39	5.661G	40	5.685G
41	5.418G	42	5.404G	43	5.671G	44	5.534G
45	5.552G	46	5.426G	47	5.354G	48	5.724G
49	5.638G	50	5.353G	51	5.558G	52	5.450G
53	5.375G	54	5.327G	55	5.460G	56	5.356G
57	5.574G	58	5.691G	59	5.606G	60	5.479G
61	5.593G	62	5.583G	63	5.420G	64	5.540G
65	5.484G	66	5.516G	67	5.586G	68	5.709G
69	5.325G	70	5.695G	71	5.435G	72	5.369G
73	5.562G	74	5.647G	75	5.713G	76	5.539G
77	5.508G	78	5.561G	79	5.512G	80	5.439G
81	5.486G	82	5.636G	83	5.510G	84	5.595G
85	5.607G	86	5.547G	87	5.637G	88	5.403G
89	5.527G	90	5.358G	91	5.541G	92	5.487G
93	5.465G	94	5.723G	95	5.571G	96	5.373G
97	5.285G	98	5.442G	99	5.466G	100	5.421G



A D T

Hopping Frequency Sequence Name: HOP_FREQ_SEQ_27							
SEQ#	Frequency (Hz)	SEQ#	Frequency (Hz)	SEQ#	Frequency (Hz)	SEQ#	Frequency (Hz)
1	5.477G	2	5.352G	3	5.394G	4	5.488G
5	5.438G	6	5.634G	7	5.563G	8	5.370G
9	5.593G	10	5.610G	11	5.702G	12	5.552G
13	5.493G	14	5.377G	15	5.376G	16	5.497G
17	5.577G	18	5.355G	19	5.609G	20	5.652G
21	5.448G	22	5.526G	23	5.499G	24	5.398G
25	5.538G	26	5.385G	27	5.391G	28	5.524G
29	5.406G	30	5.600G	31	5.345G	32	5.671G
33	5.395G	34	5.375G	35	5.387G	36	5.622G
37	5.611G	38	5.687G	39	5.407G	40	5.401G
41	5.555G	42	5.489G	43	5.426G	44	5.344G
45	5.431G	46	5.619G	47	5.324G	48	5.417G
49	5.342G	50	5.535G	51	5.356G	52	5.343G
53	5.562G	54	5.292G	55	5.674G	56	5.710G
57	5.315G	58	5.682G	59	5.369G	60	5.400G
61	5.531G	62	5.612G	63	5.392G	64	5.569G
65	5.361G	66	5.308G	67	5.436G	68	5.596G
69	5.657G	70	5.444G	71	5.483G	72	5.533G
73	5.621G	74	5.606G	75	5.566G	76	5.508G
77	5.353G	78	5.548G	79	5.681G	80	5.433G
81	5.360G	82	5.482G	83	5.418G	84	5.720G
85	5.721G	86	5.339G	87	5.712G	88	5.643G
89	5.451G	90	5.613G	91	5.576G	92	5.381G
93	5.525G	94	5.680G	95	5.678G	96	5.688G
97	5.373G	98	5.357G	99	5.487G	100	5.574G



A D T

Hopping Frequency Sequence Name: HOP_FREQ_SEQ_28							
SEQ#	Frequency (Hz)	SEQ#	Frequency (Hz)	SEQ#	Frequency (Hz)	SEQ#	Frequency (Hz)
1	5.477G	2	5.352G	3	5.394G	4	5.488G
5	5.438G	6	5.634G	7	5.563G	8	5.370G
9	5.593G	10	5.610G	11	5.702G	12	5.552G
13	5.493G	14	5.377G	15	5.376G	16	5.497G
17	5.577G	18	5.355G	19	5.609G	20	5.652G
21	5.448G	22	5.526G	23	5.499G	24	5.398G
25	5.538G	26	5.385G	27	5.391G	28	5.524G
29	5.406G	30	5.600G	31	5.345G	32	5.671G
33	5.395G	34	5.375G	35	5.387G	36	5.622G
37	5.611G	38	5.687G	39	5.407G	40	5.401G
41	5.555G	42	5.489G	43	5.426G	44	5.344G
45	5.431G	46	5.619G	47	5.324G	48	5.417G
49	5.342G	50	5.535G	51	5.356G	52	5.343G
53	5.562G	54	5.292G	55	5.674G	56	5.710G
57	5.315G	58	5.682G	59	5.369G	60	5.400G
61	5.531G	62	5.612G	63	5.392G	64	5.569G
65	5.361G	66	5.308G	67	5.436G	68	5.596G
69	5.657G	70	5.444G	71	5.483G	72	5.533G
73	5.621G	74	5.606G	75	5.566G	76	5.508G
77	5.353G	78	5.548G	79	5.681G	80	5.433G
81	5.360G	82	5.482G	83	5.418G	84	5.720G
85	5.721G	86	5.339G	87	5.712G	88	5.643G
89	5.451G	90	5.613G	91	5.576G	92	5.381G
93	5.525G	94	5.680G	95	5.678G	96	5.688G
97	5.373G	98	5.357G	99	5.487G	100	5.574G



A D T

Hopping Frequency Sequence Name: HOP_FREQ_SEQ_29							
SEQ#	Frequency (Hz)	SEQ#	Frequency (Hz)	SEQ#	Frequency (Hz)	SEQ#	Frequency (Hz)
1	5.431G	2	5.632G	3	5.318G	4	5.578G
5	5.399G	6	5.555G	7	5.537G	8	5.342G
9	5.543G	10	5.600G	11	5.679G	12	5.623G
13	5.705G	14	5.336G	15	5.364G	16	5.608G
17	5.627G	18	5.312G	19	5.660G	20	5.725G
21	5.703G	22	5.595G	23	5.550G	24	5.333G
25	5.378G	26	5.416G	27	5.430G	28	5.698G
29	5.634G	30	5.657G	31	5.400G	32	5.386G
33	5.347G	34	5.382G	35	5.403G	36	5.590G
37	5.457G	38	5.337G	39	5.510G	40	5.684G
41	5.582G	42	5.319G	43	5.408G	44	5.651G
45	5.448G	46	5.546G	47	5.674G	48	5.701G
49	5.517G	50	5.443G	51	5.390G	52	5.508G
53	5.305G	54	5.551G	55	5.394G	56	5.397G
57	5.693G	58	5.564G	59	5.645G	60	5.509G
61	5.624G	62	5.317G	63	5.480G	64	5.495G
65	5.676G	66	5.723G	67	5.530G	68	5.572G
69	5.427G	70	5.442G	71	5.688G	72	5.682G
73	5.358G	74	5.428G	75	5.652G	76	5.710G
77	5.672G	78	5.418G	79	5.521G	80	5.707G
81	5.528G	82	5.376G	83	5.349G	84	5.619G
85	5.637G	86	5.639G	87	5.518G	88	5.506G
89	5.617G	90	5.549G	91	5.324G	92	5.685G
93	5.567G	94	5.539G	95	5.692G	96	5.665G
97	5.602G	98	5.523G	99	5.675G	100	5.711G



A D T

Hopping Frequency Sequence Name: HOP_FREQ_SEQ_30							
SEQ#	Frequency (Hz)	SEQ#	Frequency (Hz)	SEQ#	Frequency (Hz)	SEQ#	Frequency (Hz)
1	5.411G	2	5.439G	3	5.488G	4	5.358G
5	5.286G	6	5.617G	7	5.471G	8	5.431G
9	5.574G	10	5.481G	11	5.365G	12	5.396G
13	5.544G	14	5.390G	15	5.721G	16	5.399G
17	5.538G	18	5.400G	19	5.565G	20	5.606G
21	5.536G	22	5.552G	23	5.516G	24	5.558G
25	5.370G	26	5.671G	27	5.566G	28	5.490G
29	5.485G	30	5.526G	31	5.389G	32	5.711G
33	5.628G	34	5.342G	35	5.340G	36	5.380G
37	5.614G	38	5.710G	39	5.534G	40	5.587G
41	5.629G	42	5.581G	43	5.590G	44	5.350G
45	5.531G	46	5.501G	47	5.478G	48	5.613G
49	5.359G	50	5.309G	51	5.364G	52	5.499G
53	5.466G	54	5.398G	55	5.635G	56	5.603G
57	5.572G	58	5.636G	59	5.532G	60	5.509G
61	5.644G	62	5.554G	63	5.638G	64	5.480G
65	5.506G	66	5.529G	67	5.586G	68	5.496G
69	5.312G	70	5.647G	71	5.649G	72	5.571G
73	5.453G	74	5.319G	75	5.579G	76	5.653G
77	5.457G	78	5.467G	79	5.583G	80	5.715G
81	5.688G	82	5.591G	83	5.433G	84	5.631G
85	5.537G	86	5.442G	87	5.701G	88	5.660G
89	5.407G	90	5.585G	91	5.621G	92	5.459G
93	5.351G	94	5.395G	95	5.455G	96	5.545G
97	5.487G	98	5.557G	99	5.563G	100	5.650G

---END---