

FCC Test Report

Report No.: RF150430E02B-1

FCC ID: PY315200309

Test Model: R8500

Received Date: May 07, 2015

Test Date: Dec. 29, 2015 to Jan. 22, 2016

Issued Date: July 29, 2016

Applicant: NETGEAR, Inc.

Address: 350 East Plumeria Drive San Jose, CA 95134

Issued By: Bureau Veritas Consumer Products Services (H.K.) Ltd., Taoyuan Branch
Hsin Chu Laboratory

Lab Address: E-2, No.1, Li Hsin 1st Road, Hsinchu Science Park, Hsinchu City 300,
Taiwan R.O.C.

Test Lab (A): Bureau Veritas Consumer Products Services (H.K.) Ltd., Taoyuan Branch
Hsin Chu Laboratory

Test Location (1): E-2, No.1, Li Hsin 1st Road, Hsinchu Science Park, Hsinchu City 300,
Taiwan R.O.C.

Test Location (2): No. 49, Ln. 206, Wende Rd., Shangshan Tsuen, Chiung Lin Hsiang, Hsin
Chu Hsien 307, Taiwan R.O.C.

Test Lab (B): Bureau Veritas Consumer Products Services (H.K.) Ltd., Taoyuan Branch
Lin Kou Laboratories

Test Location (1): No.19, Hwa Ya 2nd Rd., Wen Hwa Vil., Kwei Shan Dist., Taoyuan City
33383, TAIWAN (R.O.C.)



This report is for your exclusive use. Any copying or replication of this report to or for any other person or entity, or use of our name or trademark, is permitted only with our prior written permission. This report sets forth our findings solely with respect to the test samples identified herein. The results set forth in this report are not indicative or representative of the quality or characteristics of the lot from which a test sample was taken or any similar or identical product unless specifically and expressly noted. Our report includes all of the tests requested by you and the results thereof based upon the information that you provided to us. You have 60 days from date of issuance of this report to notify us of any material error or omission caused by our negligence, provided, however, that such notice shall be in writing and shall specifically address the issue you wish to raise. A failure to raise such issue within the prescribed time shall constitute your unqualified acceptance of the completeness of this report, the tests conducted and the correctness of the report contents. Unless specific mention, the uncertainty of measurement has been explicitly taken into account to declare the compliance or non-compliance to the specification. The report must not be used by the client to claim product certification, approval, or endorsement by TAF or any government agencies. This report contains Radiated Emissions & Band Edge Measurement (above 1GHz) test data that were produced under subcontract by Bureau Veritas Consumer Products Services (H.K.) Ltd., Taoyuan Branch Lin Kou Laboratories.

Table of Contents

Release Control Record	4
1 Certificate of Conformity	5
2 Summary of Test Results	6
2.1 Measurement Uncertainty	6
2.2 Modification Record	6
3 General Information	7
3.1 General Description of EUT (DFS Band)	7
3.2 Description of Test Modes	12
3.2.1 Test Mode Applicability and Tested Channel Detail	13
3.3 Duty Cycle of Test Signal	16
3.4 Description of Support Units	17
3.4.1 Configuration of System under Test	17
3.5 General Description of Applied Standard	18
4 Test Types and Results	19
4.1 Radiated Emission and Bandedge Measurement	19
4.1.1 Limits of Radiated Emission and Bandedge Measurement	19
4.1.2 Test Instruments	20
4.1.3 Test Procedure	22
4.1.4 Deviation from Test Standard	22
4.1.5 Test Setup	23
4.1.6 EUT Operating Condition	23
4.1.7 Test Results	24
4.2 Conducted Emission Measurement	45
4.2.1 Limits of Conducted Emission Measurement	45
4.2.2 Test Instruments	45
4.2.3 Test Procedure	46
4.2.4 Deviation from Test Standard	46
4.2.5 Test Setup	46
4.2.6 EUT Operating Condition	46
4.2.7 Test Results (Mode 1)	47
4.2.8 Test Results (Mode 2)	49
4.3 Transmit Power Measurement	51
4.3.1 Limits of Transmit Power Measurement	51
4.3.2 Test Setup	52
4.3.3 Test Instruments	52
4.3.4 Test Procedure	53
4.3.5 Deviation from Test Standard	53
4.3.6 EUT Operating Condition	53
4.3.7 Test Result	54
4.4 Peak Power Spectral Density Measurement	62
4.4.1 Limits of Peak Power Spectral Density Measurement	62
4.4.2 Test Setup	62
4.4.3 Test Instruments	62
4.4.4 Test Procedure	63
4.4.5 Deviation from Test Standard	63
4.4.6 EUT Operating Condition	63
4.4.7 Test Results	64
4.5 Frequency Stability Measurement	66
4.5.1 Limits of Frequency Stability Measurement	66
4.5.2 Test Setup	66
4.5.3 Test Instruments	66
4.5.4 Test Procedure	66
4.5.5 Deviation from Test Standard	67



4.5.6 EUT Operating Condition 67
4.5.7 Test Results 68
5 Pictures of Test Arrangements 69
Appendix – Information on the Testing Laboratories 70



A D T

Release Control Record

Issue No.	Description	Date Issued
RF150430E02B-1	Original release.	July 29, 2016

1 Certificate of Conformity

Product: Nighthawk X8 Tri Band WiFi Router

Brand: NETGEAR

Test Model: R8500

Sample Status: ENGINEERING SAMPLE

Applicant: NETGEAR, Inc.

Test Date: Dec. 29, 2015 to Jan. 22, 2016

Standard: 47 CFR FCC Part 15, Subpart E (Section 15.407)
ANSI C63.10: 2013

The above equipment has been tested by **Bureau Veritas Consumer Products Services (H.K.) Ltd., Taoyuan Branch**, and found compliance with the requirement of the above standards. The test record, data evaluation & Equipment Under Test (EUT) configurations represented herein are true and accurate accounts of the measurements of the sample's EMC characteristics under the conditions specified in this report. This report contains Radiated Emissions & Band Edge Measurement (above 1GHz) test data that were produced under subcontract by Bureau Veritas Consumer Products Services (H.K.) Ltd., Taoyuan Branch Lin Kou Laboratories.

Prepared by : Midoli Peng , **Date:** July 29, 2016
Midoli Peng / Specialist

Approved by : May Chen , **Date:** July 29, 2016
May Chen / Manager

2 Summary of Test Results

47 CFR FCC Part 15, Subpart E (SECTION 15.407)			
FCC Clause	Test Item	Result	Remarks
15.407(b)(6)	AC Power Conducted Emissions	PASS	Meet the requirement of limit. Minimum passing margin is -18.69dB at 11.99609MHz.
15.407(b)(1/2/3/4/6)	Radiated Emissions & Band Edge Measurement	PASS	Meet the requirement of limit. Minimum passing margin is -0.1dB at 5350.00MHz
15.407(a)(1/2/3)	Max Average Transmit Power	PASS	Meet the requirement of limit.
15.407(a)(1/2/3)	Peak Power Spectral Density	PASS	Meet the requirement of limit.
15.407(g)	Frequency Stability	PASS	Meet the requirement of limit.
15.203	Antenna Requirement	PASS	Antenna connector is i-pex(MHF) and i-pex not a standard connector.

NOTE: 1. This report is prepared for FCC class II permissive change. (Add DFS band: 5.26GHz ~ 5.32GHz, 5.5GHz ~ 5.7GHz).

2. The DFS report was recorded in another test report.

2.1 Measurement Uncertainty

Where relevant, the following measurement uncertainty levels have been estimated for tests performed on the EUT as specified in CISPR 16-4-2:

Measurement	Frequency	Expanded Uncertainty (k=2) (±)
Conducted Emissions at mains ports	150kHz ~ 30MHz	2.86 dB
Radiated Emissions up to 1 GHz	30MHz ~1GHz	5.37 dB
Radiated Emissions above 1 GHz	1GHz ~ 18GHz	2.29 dB
	18GHz ~ 40GHz	2.29 dB

2.2 Modification Record

There were no modifications required for compliance.

3 General Information

3.1 General Description of EUT (DFS Band)

Product	Nighthawk X8 Tri Band WiFi Router
Brand	NETGEAR
Test Model	R8500
Status of EUT	ENGINEERING SAMPLE
Power Supply Rating	19Vdc from power adapter
Modulation Type	64QAM, 16QAM, QPSK, BPSK for OFDM 256QAM for OFDM in 11ac mode
Modulation Technology	OFDM
Transfer Rate	802.11a: up to 54Mbps 802.11n: up to 600Mbps 802.11ac: up to 1733.3Mbps
Operating Frequency	5.26GHz ~ 5.32GHz, 5.5GHz ~ 5.7GHz
Number of Channel	15 for 802.11a, 802.11n (HT20), 802.11ac (VHT20) 7 for 802.11n (HT40), 802.11ac (VHT40) 3 for 802.11ac (VHT80)
Output Power	CDD Mode: 802.11a: 248.145mW 802.11ac (VHT20): 245.243mW 802.11ac (VHT40): 249.545mW 802.11ac (VHT80): 243.457mW Beamforming Mode: 802.11ac (VHT20): 245.243mW 802.11ac (VHT40): 245.888mW 802.11ac (VHT80): 237.612mW
Antenna Type	Refer to Note
Antenna Connector	Refer to Note
Accessory Device	Adapter x 1
Data Cable Supplied	Ethernet cable (shielded, 1.5m)

Note:

1. This report is prepared for FCC class II permissive change. The difference compared with the Report No.: RF150430E02C-1 design is as the following:
 - ◆ Add DFS band <5.26GHz ~ 5.32GHz, 5.5GHz ~ 5.7GHz>
2. According to above condition, all test items need to be performed. And all data were verified to meet the requirements.
3. The EUT's appearance has two different colors (black and gray), and gray was selected as representative color for the test and its data was recorded in this report.
4. The EUT has two different types could be chosen and please refer the below table:

Type	Brand	Model	Different
Type 1	NETGEAR	R8500	BRCM chipset version B1
Type 2	NETGEAR	R8500	BRCM chipset version C0

From the above type, the worst case was found in type 1. Therefore only the test data of the modes were recorded in this report.

5. The EUT must be supplied with a power adapter as following table:

No	Brand Name	Model No.	P/N	Spec.
1	NETGEAR	AD2003F10	332-10631-01	Input: 100-120Vac, 50/60Hz, 1.5A Output: 19Vdc, 3.16A DC output cable: 1.8m, unshielded
2	NETGEAR	2ABS060K 1 NA	332-10788-01	Input: 100-120Vac, 50/60Hz, 1.0A Output: 19Vdc, 3.16A DC output cable: 1.8m, unshielded

From the above adapters, the worst radiated emission was found in Adapter 1. Therefore only the test data of the modes were recorded in this report.

6. The antennas provided to the EUT, please refer to the following table:

Antenna No.	Ant. Gain(dBi)	Frequency range (GHz to GHz)	Antenna Type	Connector Type
Internal (1)	3.99	5.15~5.25	Dipole	i-pex(MHF)
	3.71	5.25~5.35	Dipole	i-pex(MHF)
	3.71	5.47~5.725	Dipole	i-pex(MHF)
	3.98	5.725~5.85	Dipole	i-pex(MHF)
Internal (2)	3.99	5.15~5.25	Dipole	i-pex(MHF)
	3.71	5.25~5.35	Dipole	i-pex(MHF)
	3.71	5.47~5.725	Dipole	i-pex(MHF)
	3.98	5.725~5.85	Dipole	i-pex(MHF)
Internal (3)	3.99	5.15~5.25	Dipole	i-pex(MHF)
	3.71	5.25~5.35	Dipole	i-pex(MHF)
	3.71	5.47~5.725	Dipole	i-pex(MHF)
	3.98	5.725~5.85	Dipole	i-pex(MHF)
Internal (4)	3.99	5.15~5.25	Dipole	i-pex(MHF)
	3.71	5.25~5.35	Dipole	i-pex(MHF)
	3.71	5.47~5.725	Dipole	i-pex(MHF)
	3.98	5.725~5.85	Dipole	i-pex(MHF)
External (1)	0.67	2.4~2.4835	Dipole	i-pex(MHF)
	-0.84	5.15~5.25	Dipole	i-pex(MHF)
	-1.38	5.25~5.35	Dipole	i-pex(MHF)
	-1.6	5.47~5.725	Dipole	i-pex(MHF)
	-1.79	5.725~5.85	Dipole	i-pex(MHF)
External (2)	0.67	2.4~2.4835	Dipole	i-pex(MHF)
	-0.84	5.15~5.25	Dipole	i-pex(MHF)
	-1.38	5.25~5.35	Dipole	i-pex(MHF)
	-1.6	5.47~5.725	Dipole	i-pex(MHF)
	-1.79	5.725~5.85	Dipole	i-pex(MHF)
External (3)	0.67	2.4~2.4835	Dipole	i-pex(MHF)
	-0.84	5.15~5.25	Dipole	i-pex(MHF)
	-1.38	5.25~5.35	Dipole	i-pex(MHF)
	-1.6	5.47~5.725	Dipole	i-pex(MHF)
	-1.79	5.725~5.85	Dipole	i-pex(MHF)
External (4)	0.67	2.4~2.4835	Dipole	i-pex(MHF)
	-0.84	5.15~5.25	Dipole	i-pex(MHF)
	-1.38	5.25~5.35	Dipole	i-pex(MHF)
	-1.6	5.47~5.725	Dipole	i-pex(MHF)
	-1.79	5.725~5.85	Dipole	i-pex(MHF)

7. The coexistence mode:

Technology		
WLAN(2.4GHz) - External Antenna	WLAN (5GHz <5150~5250MHz & 5250~5350MHz>) - External Antenna	WLAN (5GHz <5470~5725 & 5725~5850MHz>) - Internal Antenna
Note: The emission of the simultaneous operation has been evaluated and no non-compliance was found.		

8. The EUT incorporates a MIMO function with beamforming.

For 2.4GHz Band

MODULATION MODE	DATA RATE (MCS)	TX & RX CONFIGURATION	
802.11b	1 ~ 11Mbps	4TX	4RX
802.11g	6 ~ 54Mbps	4TX	4RX
802.11n (HT20)	MCS 0~7	4TX	4RX
	MCS 8~15	4TX	4RX
	MCS 16~23	4TX	4RX
	MCS 24~31	4TX	4RX
802.11n (HT40)	MCS 0~7	4TX	4RX
	MCS 8~15	4TX	4RX
	MCS 16~23	4TX	4RX
	MCS 24~31	4TX	4RX
VHT20	MCS0~8 Nss=1	4TX	4RX
	MCS0~8 Nss=2	4TX	4RX
	MCS0~9 Nss=3	4TX	4RX
	MCS0~8 Nss=4	4TX	4RX
VHT40	MCS0~9 Nss=1	4TX	4RX
	MCS0~9 Nss=2	4TX	4RX
	MCS0~9 Nss=3	4TX	4RX
	MCS0~9 Nss=4	4TX	4RX

For 5GHz Band

MODULATION MODE	DATA RATE (MCS)	TX & RX CONFIGURATION	
802.11a	6 ~ 54Mbps	4TX	4RX
802.11n (HT20)	MCS 0~7	4TX	4RX
	MCS 8~15	4TX	4RX
	MCS 16~23	4TX	4RX
	MCS 24~31	4TX	4RX
802.11n (HT40)	MCS 0~7	4TX	4RX
	MCS 8~15	4TX	4RX
	MCS 16~23	4TX	4RX
	MCS 24~31	4TX	4RX
802.11ac (VHT20)	MCS 0~8, Nss=1	4TX	4RX
	MCS 0~8, Nss=2	4TX	4RX
	MCS 0~9, Nss=3	4TX	4RX
	MCS 0~8, Nss=4	4TX	4RX
802.11ac (VHT40)	MCS 0~9, Nss=1	4TX	4RX
	MCS 0~9, Nss=2	4TX	4RX
	MCS 0~9, Nss=3	4TX	4RX
	MCS 0~9, Nss=4	4TX	4RX
802.11ac (VHT80)	MCS 0~9, Nss=1	4TX	4RX
	MCS 0~9, Nss=2	4TX	4RX
	MCS 0~9, Nss=3	4TX	4RX
	MCS 0~9, Nss=4	4TX	4RX

Note: 1. The modulation and bandwidth are similar for 802.11n mode for 20MHz (40MHz) and 802.11ac mode for 20MHz (40MHz), therefore investigated worst case to representative mode in test report. (Final test mode refer section 3.2.1)

2. All of modulation mode support beamforming function except 802.11a/b/g modulation mode.

9. The Directional gain table:

Frequency (MHz)	Max Gain (dBi)
5470~5725	6.23

Note:

1. Non-TxBF mode & TxBF mode antenna gain refer to KDB 662911 F 2) f) (ii)

$$DirectionalGain = 10 \cdot \log \left[\frac{\sum_{j=1}^{N_{SS}} \left\{ \sum_{k=1}^{N_{ANT}} g_{j,k} \right\}^2}{N_{ANT}} \right]$$

where

Each antenna is driven by no more than one spatial stream;

N_{SS} = the number of independent spatial streams of data;

N_{ANT} = the total number of antennas

$g_{j,k} = 10^{G_k / 20}$ if the k th antenna is being fed by spatial stream j , or zero if it is not;

G_k is the gain in dBi of the k th antenna.

10. The above EUT information is declared by manufacturer and for more detailed features description, please refer to the manufacturer's specifications or user's manual.

3.2 Description of Test Modes

For 5260 ~ 5320MHz

4 channels are provided for 802.11a, 802.11n (HT20), 802.11ac (VHT20):

Channel	Frequency	Channel	Frequency
52	5260 MHz	60	5300 MHz
56	5280 MHz	64	5320 MHz

2 channels are provided for 802.11n (HT40), 802.11ac (VHT40):

Channel	Frequency	Channel	Frequency
54	5270 MHz	62	5310 MHz

1 channel is provided for 802.11ac (VHT80):

Channel	Frequency
58	5290MHz

For 5500 ~ 5700MHz

11 channels are provided for 802.11a, 802.11n (HT20), 802.11ac (VHT20):

Channel	Frequency	Channel	Frequency
100	5500 MHz	124	5620 MHz
104	5520 MHz	128	5640 MHz
108	5540 MHz	132	5660 MHz
112	5560 MHz	136	5680 MHz
116	5580 MHz	140	5700 MHz
120	5600 MHz		

5 channels are provided for 802.11n (HT40), 802.11ac (VHT40):

Channel	Frequency	Channel	Frequency
102	5510 MHz	126	5630 MHz
110	5550 MHz	134	5670 MHz
118	5590 MHz		

2 channels are provided for 802.11ac (VHT80):

Channel	Frequency	Channel	Frequency
106	5530MHz	122	5610MHz

3.2.1 Test Mode Applicability and Tested Channel Detail

EUT CONFIGURE MODE	APPLICABLE TO				DESCRIPTION
	RE \geq 1G	RE $<$ 1G	PLC	APCM	
1	√	√	√	√	With adapter 1
2	-	-	√	-	With adapter 2

Where **RE \geq 1G**: Radiated Emission above 1GHz **RE $<$ 1G**: Radiated Emission below 1GHz
PLC: Power Line Conducted Emission **APCM**: Antenna Port Conducted Measurement

NOTE:

1. The test mode was reference to the worst case in the original test report.
2. "-" means no effect.

Radiated Emission Test (Above 1GHz):

- Pre-Scan has been conducted to determine the worst-case mode from all possible combinations between available modulations, data rates and antenna ports (if EUT with antenna diversity architecture).
- Following channel(s) was (were) selected for the final test as listed below.

CDD MODE						
MODE	FREQ. BAND (MHz)	AVAILABLE CHANNEL	TESTED CHANNEL	MODULATION TECHNOLOGY	MODULATION TYPE	DATA RATE (Mbps)
802.11a	5260-5320	52 to 64	52, 60, 64	OFDM	BPSK	6
802.11ac (VHT20)		52 to 64	52, 60, 64	OFDM	BPSK	6.5
802.11ac (VHT40)		54 to 62	54, 62	OFDM	BPSK	13.5
802.11ac (VHT80)		58	58	OFDM	BPSK	29.3
802.11a	5500-5700	100 to 140	100, 116, 140	OFDM	BPSK	6
802.11ac (VHT20)		100 to 140	100, 116, 140	OFDM	BPSK	6.5
802.11ac (VHT40)		102 to 134	102, 110, 134	OFDM	BPSK	13.5
802.11ac (VHT80)		106 to 122	106, 122	OFDM	BPSK	29.3

Radiated Emission Test (Below 1GHz):

- Pre-Scan has been conducted to determine the worst-case mode from all possible combinations between available modulations, data rates and antenna ports (if EUT with antenna diversity architecture).
- Following channel(s) was (were) selected for the final test as listed below.

CDD MODE						
MODE	FREQ. BAND (MHz)	AVAILABLE CHANNEL	TESTED CHANNEL	MODULATION TECHNOLOGY	MODULATION TYPE	DATA RATE (Mbps)
802.11ac (VHT40)	5260-5320 5500-5700	54 to 62 102 to 134	102	OFDM	BPSK	13.5

Power Line Conducted Emission Test:

- Pre-Scan has been conducted to determine the worst-case mode from all possible combinations between available modulations, data rates and antenna ports (if EUT with antenna diversity architecture).
- Following channel(s) was (were) selected for the final test as listed below.

CDD MODE						
MODE	FREQ. BAND (MHz)	AVAILABLE CHANNEL	TESTED CHANNEL	MODULATION TECHNOLOGY	MODULATION TYPE	DATA RATE (Mbps)
802.11ac (VHT40)	5260-5320 5500-5700	54 to 62 102 to 134	102	OFDM	BPSK	13.5

Antenna Port Conducted Measurement:

- This item includes all test value of each mode, but only includes spectrum plot of worst value of each mode.
- Pre-Scan has been conducted to determine the worst-case mode from all possible combinations between available modulations, data rates and antenna ports (if EUT with antenna diversity architecture).
- Following channel(s) was (were) selected for the final test as listed below.

CDD MODE						
For Transmit Power / Power Spectral Density Measurement						
MODE	FREQ. BAND (MHz)	AVAILABLE CHANNEL	TESTED CHANNEL	MODULATION TECHNOLOGY	MODULATION TYPE	DATA RATE (Mbps)
802.11a	5260-5320	52 to 64	52, 60, 64	OFDM	BPSK	6
802.11ac (VHT20)		52 to 64	52, 60, 64	OFDM	BPSK	6.5
802.11ac (VHT40)		54 to 62	54, 62	OFDM	BPSK	13.5
802.11ac (VHT80)		58	58	OFDM	BPSK	29.3
802.11a	5500-5700	100 to 140	100, 116, 140	OFDM	BPSK	6
802.11ac (VHT20)		100 to 140	100, 116, 140	OFDM	BPSK	6.5
802.11ac (VHT40)		102 to 134	102, 110, 134	OFDM	BPSK	13.5
802.11ac (VHT80)		106 to 122	106, 122	OFDM	BPSK	29.3
Beamforming MODE						
For Transmit Power Measurement						
MODE	FREQ. BAND (MHz)	AVAILABLE CHANNEL	TESTED CHANNEL	MODULATION TECHNOLOGY	MODULATION TYPE	DATA RATE (Mbps)
802.11ac (VHT20)	5260-5320	52 to 64	52, 60, 64	OFDM	BPSK	6.5
802.11ac (VHT40)		54 to 62	54, 62	OFDM	BPSK	13.5
802.11ac (VHT80)		58	58	OFDM	BPSK	29.3
802.11ac (VHT20)	5500-5700	100 to 140	100, 116, 140	OFDM	BPSK	6.5
802.11ac (VHT40)		102 to 134	102, 110, 134	OFDM	BPSK	13.5
802.11ac (VHT80)		106 to 122	106, 122	OFDM	BPSK	29.3



Test Condition:

APPLICABLE TO	ENVIRONMENTAL CONDITIONS	INPUT POWER	TESTED BY	TEST LOCATION
RE \geq 1G	24deg. C, 65%RH	120Vac, 60Hz	Alen Wu	1(Hwa Ya)
RE $<$ 1G	24deg. C, 68%RH	120Vac, 60Hz	Weiwei Lo	2
PLC	25deg. C, 68%RH	120Vac, 60Hz	Jason Huang	2
APCM	25deg. C, 60%RH	120Vac, 60Hz	Anderson Chen	1(Hsinchu)

3.3 Duty Cycle of Test Signal

If duty cycle of test signal is $\geq 98\%$, duty factor is not required.

If duty cycle of test signal is $< 98\%$, duty factor shall be considered.

802.11a: Duty cycle = $2.067 \text{ ms} / 2.087 \text{ ms} = 0.99$

802.11ac (VHT20): Duty cycle = $1.926 \text{ ms} / 1.95 \text{ ms} = 0.988$

802.11ac (VHT40): Duty cycle = $0.947 \text{ ms} / 0.965 \text{ ms} = 0.981$

802.11ac (VHT80): Duty cycle = $0.455 \text{ ms} / 0.478 \text{ ms} = 0.952$, Duty factor = $10 * \log(1/0.952) = 0.21$

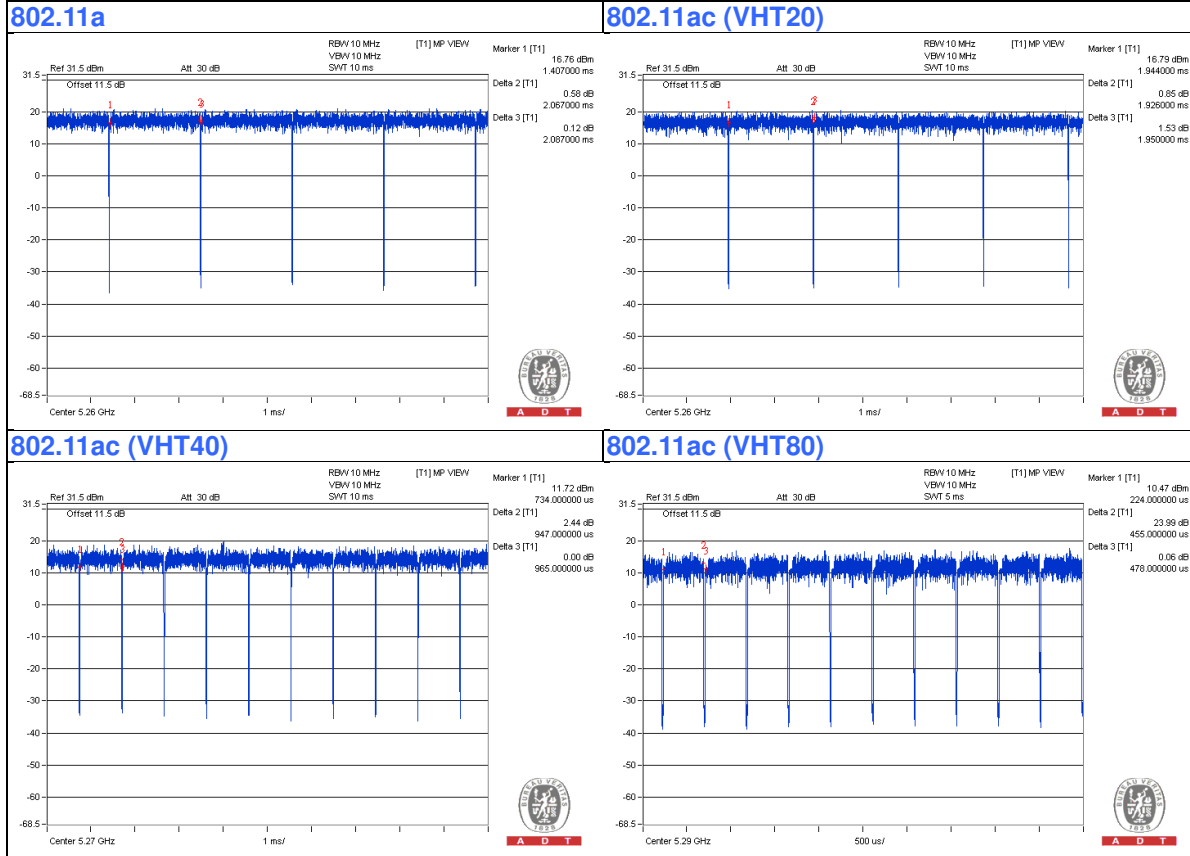

3.4 Description of Support Units

The EUT has been tested as an independent unit together with other necessary accessories or support units. The following support units or accessories were used to form a representative test configuration during the tests.

No.	Product	Brand	Model No.	Serial No.	FCC ID	Remark
A	USB Flash Driver	Transcend	JetFlash 790	NA	NA	Provided by Lab
B	USB Flash Driver	Transcend	JetFlash 790	NA	NA	Provided by Lab
C	NOTEBOOK COMPUTER	DELL	PP32LA	HSLB32S	FCC DoC	Provided by Lab
D	NOTEBOOK COMPUTER	DELL	E5430	4YV4VY1	FCC DoC	Provided by Lab
E	HUB	ZyXEL	ES-116P	S060H02000215	FCC DoC	Provided by Lab

NOTE:

- All power cords of the above support units are non-shielded (1.8 m).

No.	Cable	Qty.	Length (m)	Shielded (Yes/ No)	Cores (Number)	Remark
1	DC	1	1.8	No	0	Supplied by Client
2	RJ45	1	10	No	0	Provided by Lab
3	RJ45	5	10	No	0	Provided by Lab
4	RJ45	1	10	No	0	Provided by Lab

3.4.1 Configuration of System under Test

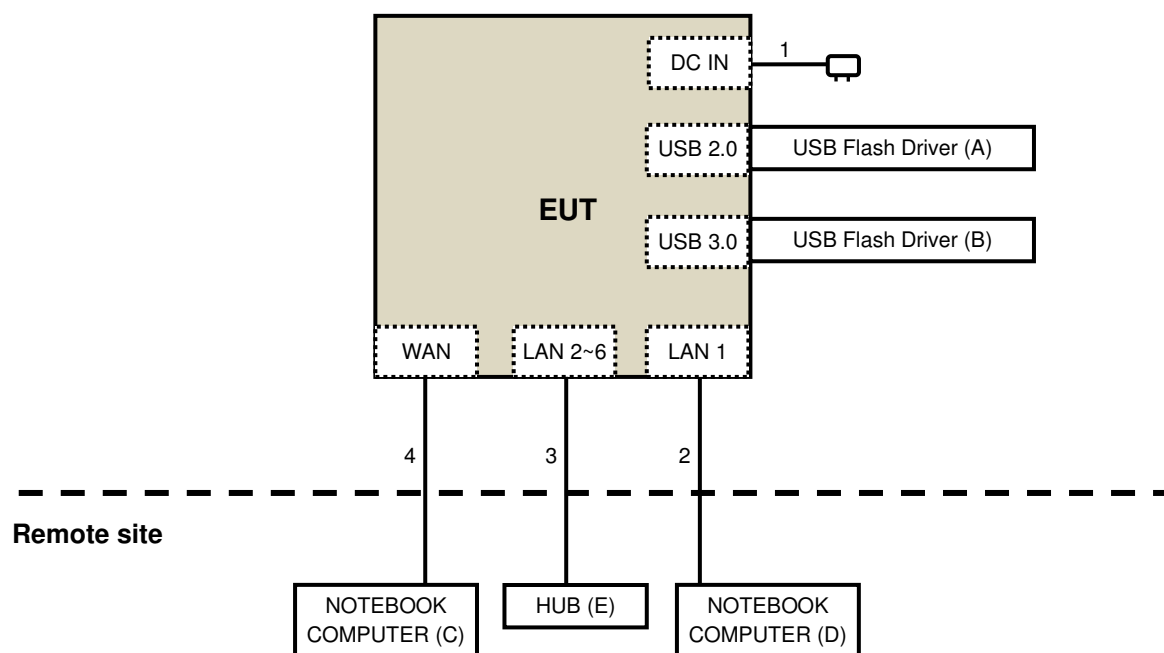



3.5 General Description of Applied Standard

The EUT is a RF Product. According to the specifications of the manufacturer, it must comply with the requirements of the following standards:

FCC Part 15, Subpart E (15.407)

KDB 789033 D02 General UNII Test Procedure New Rules v01r02

KDB 662911 D01 Multiple Transmitter Output v02r01

ANSI C63.10-2013

All test items have been performed and recorded as per the above standards.

NOTE: The EUT has been verified to comply with the requirements of FCC Part 15, Subpart B, Class B (DoC). The test report has been issued separately.

4 Test Types and Results

4.1 Radiated Emission and Bandedge Measurement

4.1.1 Limits of Radiated Emission and Bandedge Measurement

Radiated emissions which fall in the restricted bands must comply with the radiated emission limits specified as below table.

Frequencies (MHz)	Field Strength (microvolts/meter)	Measurement Distance (meters)
0.009 ~ 0.490	2400/F(kHz)	300
0.490 ~ 1.705	24000/F(kHz)	30
1.705 ~ 30.0	30	30
30 ~ 88	100	3
88 ~ 216	150	3
216 ~ 960	200	3
Above 960	500	3

NOTE:

1. The lower limit shall apply at the transition frequencies.
2. Emission level (dBuV/m) = 20 log Emission level (uV/m).
3. For frequencies above 1000MHz, the field strength limits are based on average detector, however, the peak field strength of any emission shall not exceed the maximum permitted average limits, specified above by more than 20dB under any condition of modulation.

LIMITS OF UNWANTED EMISSION OUT OF THE RESTRICTED BANDS

APPLICABLE TO	LIMIT	
KDB 789033 D02 General UNII Test Procedure New Rules v01r02	FIELD STRENGTH AT 3m	
	PK:74 (dBμV/m)	AV:54 (dBμV/m)
APPLICABLE TO	EIRP LIMIT	EQUIVALENT FIELD STRENGTH AT 3m
15.407(b)(1)	PK:-27 (dBm/MHz)	PK:68.2(dBμV/m)
15.407(b)(2)		
15.407(b)(3)		
15.407(b)(4)	PK:-27 (dBm/MHz) ^{*1} PK:-17 (dBm/MHz) ^{*2}	PK: 68.2(dBμV/m) ^{*1} PK:78.2 (dBμV/m) ^{*2}

NOTE: ^{*1} beyond 10MHz of the band edge ^{*2} within 10 MHz of band edge

The following formula is used to convert the equipment isotropic radiated power (eirp) to field strength:

$$E = \frac{1000000\sqrt{30P}}{3} \mu\text{V/m, where P is the eirp (Watts).}$$



A D T

4.1.2 Test Instruments

For above 1GHz test:

DESCRIPTION & MANUFACTURER	MODEL NO.	SERIAL NO.	CALIBRATED DATE	CALIBRATED UNTIL
Test Receiver ROHDE & SCHWARZ	ESCI	100424	Oct. 12, 2015	Oct. 11, 2016
Spectrum Analyzer ROHDE & SCHWARZ	FSP40	100040	July 08, 2015	July 07, 2016
BILOG Antenna SCHWARZBECK	VULB9168	9168-155	Feb. 06, 2015	Feb. 05, 2016
HORN Antenna SCHWARZBECK	BBHA 9120D	9120D-1170	Feb. 05, 2015	Feb. 04, 2016
HORN Antenna SCHWARZBECK	BBHA 9170	BBHA9170241	Feb. 09, 2015	Feb. 08, 2016
Preamplifier Agilent	8449B	3008A01960	Aug. 09, 2015	Aug. 08, 2016
Preamplifier Agilent	8447D	2944A10631	Aug. 09, 2015	Aug. 08, 2016
RF signal cable HUBER+SUHNER	SUCOFLEX 104	Cable-CH4-02(295012+309220)	Aug. 09, 2015	Aug. 08, 2016
RF signal cable HUBER+SUHNER	SUCOFLEX 104	Cable-CH4-03(250724)	Aug. 09, 2015	Aug. 08, 2016
Software BV ADT	ADT_Radiated_ V7.6.15.9.4	NA	NA	NA
Antenna Tower inn-co GmbH	MA 4000	010303	NA	NA
Antenna Tower Controller BV ADT	AT100	AT93021703	NA	NA
Turn Table BV ADT	TT100	TT93021703	NA	NA
Turn Table Controller BV ADT	SC100.	SC93021703	NA	NA
26GHz ~ 40GHz Amplifier	EM26400	815221	Oct. 18, 2015	Oct. 17, 2016
High Speed Peak Power Meter	ML2495A	0824011	July 09, 2015	July 08, 2016
Power Sensor	MA2411B	0738171	July 09, 2015	July 08, 2016
WIT Standard Temperature And Humidity Chamber	TH-4S-C	W981030	June 08, 2015	June 07, 2016

- Note: 1. The calibration interval of the above test instruments is 12 months and the calibrations are traceable to NML/ROC and NIST/USA.
2. The test was performed in HwaYa Chamber 4.
3. The FCC Site Registration No. is 460141.
4. The IC Site Registration No. is IC7450F-4.
5. Tested Date: Dec. 29, 2015



For below 1GHz test:

DESCRIPTION & MANUFACTURER	MODEL NO.	SERIAL NO.	CALIBRATED DATE	CALIBRATED UNTIL
Test Receiver Agilent	N9038A	MY51210105	July 24, 2015	July 23, 2016
Pre-Amplifier ^(*) EMCI	EMC001340	980142	Jan. 20, 2016	Jan. 19, 2018
Loop Antenna ^(*) Electro-Metrics	EM-6879	264	Dec. 16, 2014	Dec. 15, 2016
RF Cable	NA	LOOPCAB-001 LOOPCAB-002	Jan. 18, 2016	Jan. 17, 2017
Pre-Amplifier Mini-Circuits	ZFL-1000VH2 B	AMP-ZFL-03	Nov. 11, 2015	Nov. 10, 2016
Trilog Broadband Antenna SCHWARZBECK	VULB 9168	9168-360	Feb. 06, 2015	Feb. 05, 2016
RF Cable	8D-FB	CHGCAB-001 -1 CHGCAB-001 -2	Oct. 03, 2015	Oct. 02, 2016
	RF-141	CHGCAB-004	Oct. 03, 2015	Oct. 02, 2016
Software	ADT_Radiated _V8.7.07	NA	NA	NA
Antenna Tower & Turn Table CT	NA	NA	NA	NA

Note:

1. The calibration interval of the above test instruments is 12 months and the calibrations are traceable to NML/ROC and NIST/USA.
2. *The calibration interval of the above test instruments is 24 months and the calibrations are traceable to NML/ROC and NIST/USA.
3. Loop antenna was used for all emissions below 30 MHz.
4. The test was performed in 966 Chamber No. G.
5. The FCC Site Registration No. is 966073.
6. The CANADA Site Registration No. is IC 7450H-2.
7. Tested Date: Jan. 22, 2016

4.1.3 Test Procedure

- a. The EUT was placed on the top of a rotating table 0.8 meters (for below 1GHz) / 1.5 meters (for above 1GHz) above the ground at 3 meter chamber room for test. The table was rotated 360 degrees to determine the position of the highest radiation.
- b. The EUT was set 3 meters away from the interference-receiving antenna, which was mounted on the top of a variable-height antenna tower.
- c. The height of antenna is varied from one meter to four meters above the ground to determine the maximum value of the field strength. Both horizontal and vertical polarizations of the antenna are set to make the measurement.
- d. For each suspected emission, the EUT was arranged to its worst case and then the antenna was tuned to heights from 1 meter to 4 meters and the rotatable table was turned from 0 degrees to 360 degrees to find the maximum reading.
- e. The test-receiver system was set to quasi-peak detect function and specified bandwidth with maximum hold mode when the test frequency is below 1 GHz.
- f. The test-receiver system was set to peak and average detect function and specified bandwidth with maximum hold mode when the test frequency is above 1 GHz. If the peak reading value also meets average limit, measurement with the average detector is unnecessary.

Note:

1. The resolution bandwidth and video bandwidth of test receiver/spectrum analyzer is 120kHz for Quasi-peak detection (QP) at frequency below 1GHz.
2. The resolution bandwidth of test receiver/spectrum analyzer is 1 MHz and the video bandwidth is 3 MHz for Peak detection (PK) at frequency above 1GHz.
3. The resolution bandwidth of test receiver/spectrum analyzer is 1MHz and the video bandwidth is 3MHz for RMS Average (Duty cycle < 98%) for Average detection (AV) at frequency above 1GHz, then the measurement results was added to a correction factor ($10 \log(1/\text{duty cycle})$).
4. The resolution bandwidth of test receiver/spectrum analyzer is 1MHz and the video bandwidth is 10Hz (Duty cycle \geq 98%) for Average detection (AV) at frequency above 1GHz.
5. All modes of operation were investigated and the worst-case emissions are reported.

4.1.4 Deviation from Test Standard

No deviation.

4.1.5 Test Setup

<Frequency Range below 1GHz>

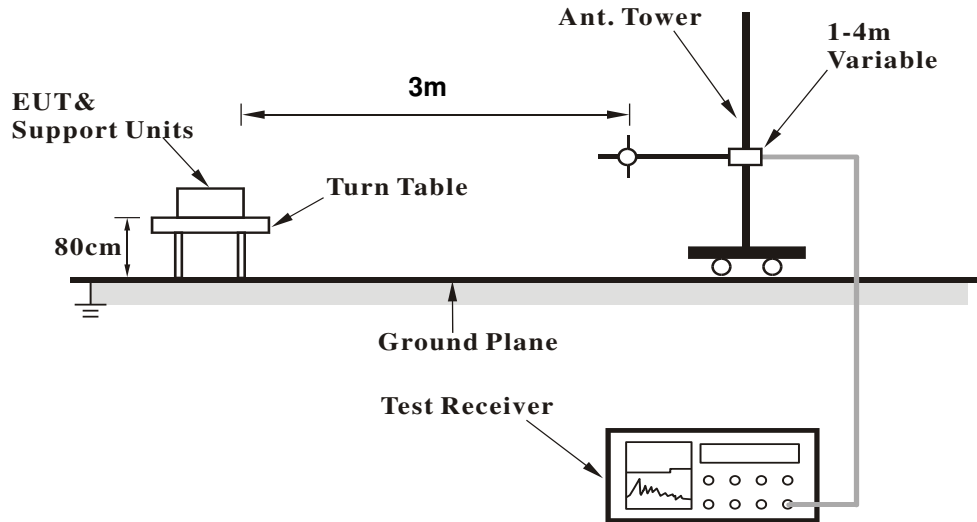

<Frequency Range above 1GHz>

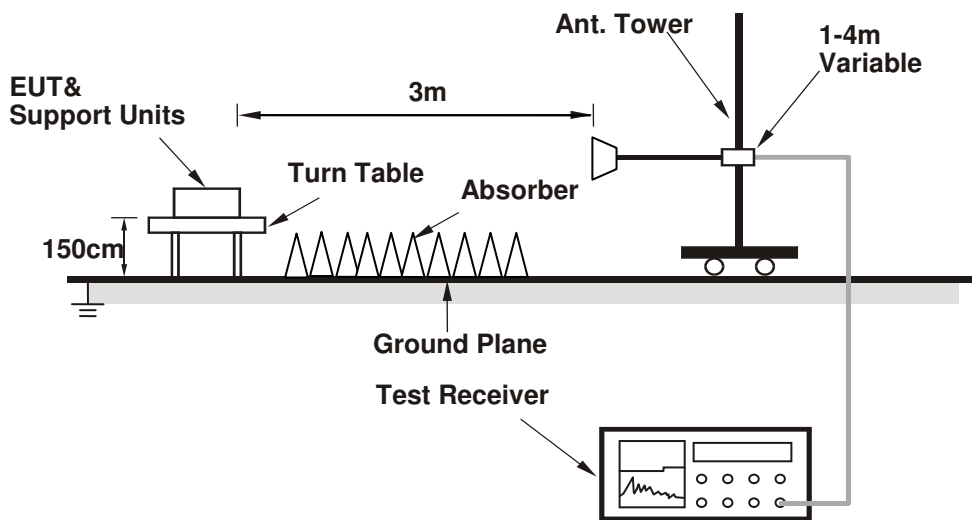

For the actual test configuration, please refer to the attached file (Test Setup Photo).

4.1.6 EUT Operating Condition

1. Connect the EUT with the support units C-D (Notebook Computer) which is placed on remote site.
2. Controlling software (Mtool.exe_2_0_2_7) has been activated to set the EUT on specific status.

4.1.7 Test Results

Above 1GHz Data (Subcontract Item)

CDD Mode

802.11a

CHANNEL	TX Channel 52	DETECTOR FUNCTION	Peak (PK)
FREQUENCY RANGE	1GHz ~ 40GHz		Average (AV)

ANTENNA POLARITY & TEST DISTANCE: HORIZONTAL AT 3 M

NO.	FREQ. (MHz)	EMISSION LEVEL (dBuV/m)	LIMIT (dBuV/m)	MARGIN (dB)	ANTENNA HEIGHT (m)	TABLE ANGLE (Degree)	RAW VALUE (dBuV)	CORRECTION FACTOR (dB/m)
1	5100.00	56.3 PK	74.0	-17.7	1.19 H	109	51.38	4.92
2	5100.00	45.3 AV	54.0	-8.7	1.19 H	109	40.38	4.92
3	*5260.00	115.4 PK			1.19 H	109	110.25	5.15
4	*5260.00	105.8 AV			1.19 H	109	100.65	5.15
5	#10520.00	66.7 PK	74.0	-7.3	1.16 H	79	50.38	16.32
6	#10520.00	51.1 AV	54.0	-2.9	1.16 H	79	34.78	16.32
7	15780.00	55.4 PK	74.0	-18.6	1.32 H	117	38.30	17.10
8	15780.00	42.4 AV	54.0	-11.6	1.32 H	117	25.30	17.10

ANTENNA POLARITY & TEST DISTANCE: VERTICAL AT 3 M

NO.	FREQ. (MHz)	EMISSION LEVEL (dBuV/m)	LIMIT (dBuV/m)	MARGIN (dB)	ANTENNA HEIGHT (m)	TABLE ANGLE (Degree)	RAW VALUE (dBuV)	CORRECTION FACTOR (dB/m)
1	5100.00	58.7 PK	74.0	-15.3	1.45 V	128	53.78	4.92
2	5100.00	47.7 AV	54.0	-6.3	1.45 V	128	42.78	4.92
3	*5260.00	118.1 PK			1.48 V	129	112.95	5.15
4	*5260.00	108.6 AV			1.48 V	129	103.45	5.15
5	#10520.00	69.0 PK	74.0	-5.0	1.00 V	266	52.68	16.32
6	#10520.00	53.5 AV	54.0	-0.5	1.00 V	266	37.18	16.32
7	15780.00	55.4 PK	74.0	-18.6	1.38 V	60	38.30	17.10
8	15780.00	42.0 AV	54.0	-12.0	1.38 V	60	24.90	17.10

REMARKS:

1. Emission Level(dBuV/m) = Raw Value(dBuV) + Correction Factor(dB/m)
2. Correction Factor(dB/m) = Antenna Factor(dB/m) + Cable Factor(dB) – Pre-Amplifier Factor(dB)
3. The other emission levels were very low against the limit.
4. Margin value = Emission Level – Limit value
5. " * " : Fundamental frequency.
6. " # " : The radiated frequency is out of the restricted band.



CHANNEL	TX Channel 60	DETECTOR FUNCTION	Peak (PK)
FREQUENCY RANGE	1GHz ~ 40GHz		Average (AV)

ANTENNA POLARITY & TEST DISTANCE: HORIZONTAL AT 3 M

NO.	FREQ. (MHz)	EMISSION LEVEL (dBuV/m)	LIMIT (dBuV/m)	MARGIN (dB)	ANTENNA HEIGHT (m)	TABLE ANGLE (Degree)	RAW VALUE (dBuV)	CORRECTION FACTOR (dB/m)
1	5140.00	58.0 PK	74.0	-16.0	1.11 H	99	53.03	4.97
2	5140.00	45.8 AV	54.0	-8.2	1.11 H	99	40.83	4.97
3	*5300.00	114.6 PK			1.11 H	99	109.38	5.22
4	*5300.00	104.5 AV			1.11 H	99	99.28	5.22
5	10600.00	66.1 PK	74.0	-7.9	1.19 H	85	49.65	16.45
6	10600.00	51.2 AV	54.0	-2.8	1.19 H	85	34.75	16.45
7	15900.00	55.4 PK	74.0	-18.6	1.24 H	105	38.84	16.56
8	15900.00	42.6 AV	54.0	-11.4	1.24 H	105	26.04	16.56

ANTENNA POLARITY & TEST DISTANCE: VERTICAL AT 3 M

NO.	FREQ. (MHz)	EMISSION LEVEL (dBuV/m)	LIMIT (dBuV/m)	MARGIN (dB)	ANTENNA HEIGHT (m)	TABLE ANGLE (Degree)	RAW VALUE (dBuV)	CORRECTION FACTOR (dB/m)
1	5140.00	60.2 PK	74.0	-13.8	1.41 V	129	55.23	4.97
2	5140.00	48.0 AV	54.0	-6.0	1.41 V	129	43.03	4.97
3	*5300.00	117.3 PK			1.39 V	181	112.08	5.22
4	*5300.00	107.4 AV			1.39 V	181	102.18	5.22
5	10600.00	68.3 PK	74.0	-5.7	1.00 V	188	51.85	16.45
6	10600.00	53.6 AV	54.0	-0.4	1.00 V	188	37.15	16.45
7	15900.00	55.0 PK	74.0	-19.0	1.26 V	44	38.44	16.56
8	15900.00	42.0 AV	54.0	-12.0	1.26 V	44	25.44	16.56

REMARKS:

1. Emission Level(dBuV/m) = Raw Value(dBuV) + Correction Factor(dB/m)
2. Correction Factor(dB/m) = Antenna Factor(dB/m) + Cable Factor(dB) – Pre-Amplifier Factor(dB)
3. The other emission levels were very low against the limit.
4. Margin value = Emission Level – Limit value
5. " * ": Fundamental frequency.



CHANNEL	TX Channel 64	DETECTOR FUNCTION	Peak (PK)
FREQUENCY RANGE	1GHz ~ 40GHz		Average (AV)

ANTENNA POLARITY & TEST DISTANCE: HORIZONTAL AT 3 M

NO.	FREQ. (MHz)	EMISSION LEVEL (dBuV/m)	LIMIT (dBuV/m)	MARGIN (dB)	ANTENNA HEIGHT (m)	TABLE ANGLE (Degree)	RAW VALUE (dBuV)	CORRECTION FACTOR (dB/m)
1	*5320.00	116.0 PK			1.20 H	109	110.72	5.28
2	*5320.00	105.3 AV			1.20 H	109	100.02	5.28
3	5350.00	66.2 PK	74.0	-7.8	1.20 H	109	60.84	5.36
4	5350.00	51.6 AV	54.0	-2.4	1.20 H	109	46.24	5.36
5	10640.00	65.4 PK	74.0	-8.6	1.16 H	89	49.07	16.33
6	10640.00	51.1 AV	54.0	-2.9	1.16 H	89	34.77	16.33
7	15960.00	55.4 PK	74.0	-18.6	1.33 H	95	38.70	16.70
8	15960.00	42.1 AV	54.0	-11.9	1.33 H	95	25.40	16.70

ANTENNA POLARITY & TEST DISTANCE: VERTICAL AT 3 M

NO.	FREQ. (MHz)	EMISSION LEVEL (dBuV/m)	LIMIT (dBuV/m)	MARGIN (dB)	ANTENNA HEIGHT (m)	TABLE ANGLE (Degree)	RAW VALUE (dBuV)	CORRECTION FACTOR (dB/m)
1	*5320.00	118.5 PK			1.59 V	152	113.22	5.28
2	*5320.00	108.3 AV			1.59 V	152	103.02	5.28
3	5350.00	68.6 PK	74.0	-5.4	1.59 V	152	63.24	5.36
4	5350.00	53.9 AV	54.0	-0.1	1.59 V	152	48.54	5.36
5	10640.00	67.8 PK	74.0	-6.2	1.00 V	113	51.47	16.33
6	10640.00	53.3 AV	54.0	-0.7	1.00 V	113	36.97	16.33
7	15960.00	55.1 PK	74.0	-18.9	1.26 V	61	38.40	16.70
8	15960.00	42.0 AV	54.0	-12.0	1.26 V	61	25.30	16.70

REMARKS:

1. Emission Level(dBuV/m) = Raw Value(dBuV) + Correction Factor(dB/m)
2. Correction Factor(dB/m) = Antenna Factor(dB/m) + Cable Factor(dB) – Pre-Amplifier Factor(dB)
3. The other emission levels were very low against the limit.
4. Margin value = Emission Level – Limit value
5. " * ": Fundamental frequency.

CHANNEL	TX Channel 100	DETECTOR FUNCTION	Peak (PK)
FREQUENCY RANGE	1GHz ~ 40GHz		Average (AV)

ANTENNA POLARITY & TEST DISTANCE: HORIZONTAL AT 3 M

NO.	FREQ. (MHz)	EMISSION LEVEL (dBuV/m)	LIMIT (dBuV/m)	MARGIN (dB)	ANTENNA HEIGHT (m)	TABLE ANGLE (Degree)	RAW VALUE (dBuV)	CORRECTION FACTOR (dB/m)
1	5460.00	59.1 PK	74.0	-14.9	1.22 H	118	53.48	5.62
2	5460.00	46.9 AV	54.0	-7.1	1.22 H	118	41.28	5.62
3	#5466.00	67.8 PK	74.0	-6.2	1.22 H	118	62.17	5.63
4	#5466.00	51.2 AV	54.0	-2.8	1.22 H	118	45.57	5.63
5	*5500.00	116.3 PK			1.22 H	118	110.60	5.70
6	*5500.00	105.8 AV			1.22 H	118	100.10	5.70
7	11000.00	59.1 PK	74.0	-14.9	1.09 H	78	41.92	17.18
8	11000.00	47.0 AV	54.0	-7.0	1.09 H	78	29.82	17.18
9	#16500.00	55.2 PK	74.0	-18.8	1.26 H	107	35.66	19.54
10	#16500.00	42.1 AV	54.0	-11.9	1.26 H	107	22.56	19.54

ANTENNA POLARITY & TEST DISTANCE: VERTICAL AT 3 M

NO.	FREQ. (MHz)	EMISSION LEVEL (dBuV/m)	LIMIT (dBuV/m)	MARGIN (dB)	ANTENNA HEIGHT (m)	TABLE ANGLE (Degree)	RAW VALUE (dBuV)	CORRECTION FACTOR (dB/m)
1	5460.00	61.3 PK	74.0	-12.7	1.00 V	279	55.68	5.62
2	5460.00	49.0 AV	54.0	-5.0	1.00 V	279	43.38	5.62
3	#5466.00	70.0 PK	74.0	-4.0	1.00 V	279	64.37	5.63
4	#5466.00	53.5 AV	54.0	-0.5	1.00 V	279	47.87	5.63
5	*5500.00	118.8 PK			1.00 V	279	113.10	5.70
6	*5500.00	108.8 AV			1.00 V	279	103.10	5.70
7	11000.00	61.4 PK	74.0	-12.6	1.00 V	10	44.22	17.18
8	11000.00	49.1 AV	54.0	-4.9	1.00 V	10	31.92	17.18
9	#16500.00	55.6 PK	74.0	-18.4	1.34 V	36	36.06	19.54
10	#16500.00	42.1 AV	54.0	-11.9	1.34 V	36	22.56	19.54

REMARKS:

- Emission Level(dBuV/m) = Raw Value(dBuV) + Correction Factor(dB/m)
- Correction Factor(dB/m) = Antenna Factor(dB/m) + Cable Factor(dB) – Pre-Amplifier Factor(dB)
- The other emission levels were very low against the limit.
- Margin value = Emission Level – Limit value
- " * ": Fundamental frequency.
- " # ": The radiated frequency is out of the restricted band.



CHANNEL	TX Channel 116	DETECTOR FUNCTION	Peak (PK)
FREQUENCY RANGE	1GHz ~ 40GHz		Average (AV)

ANTENNA POLARITY & TEST DISTANCE: HORIZONTAL AT 3 M

NO.	FREQ. (MHz)	EMISSION LEVEL (dBuV/m)	LIMIT (dBuV/m)	MARGIN (dB)	ANTENNA HEIGHT (m)	TABLE ANGLE (Degree)	RAW VALUE (dBuV)	CORRECTION FACTOR (dB/m)
1	*5580.00	117.1 PK			1.20 H	115	111.33	5.77
2	*5580.00	106.7 AV			1.20 H	115	100.93	5.77
3	#5740.00	65.4 PK	68.2	-2.8	1.20 H	115	59.21	6.19
4	11160.00	59.8 PK	74.0	-14.2	1.22 H	101	42.63	17.17
5	11160.00	47.6 AV	54.0	-6.4	1.22 H	101	30.43	17.17
6	#16740.00	54.7 PK	68.2	-13.5	1.30 H	116	35.02	19.68

ANTENNA POLARITY & TEST DISTANCE: VERTICAL AT 3 M

NO.	FREQ. (MHz)	EMISSION LEVEL (dBuV/m)	LIMIT (dBuV/m)	MARGIN (dB)	ANTENNA HEIGHT (m)	TABLE ANGLE (Degree)	RAW VALUE (dBuV)	CORRECTION FACTOR (dB/m)
1	*5580.00	119.4 PK			1.00 V	278	113.63	5.77
2	*5580.00	109.7 AV			1.00 V	278	103.93	5.77
3	#5740.00	67.8 PK	68.2	-0.4	1.14 V	92	61.61	6.19
4	11160.00	62.1 PK	74.0	-11.9	1.00 V	14	44.93	17.17
5	11160.00	49.9 AV	54.0	-4.1	1.00 V	14	32.73	17.17
6	#16740.00	55.2 PK	68.2	-13.0	1.29 V	43	35.52	19.68

REMARKS:

1. Emission Level(dBuV/m) = Raw Value(dBuV) + Correction Factor(dB/m)
2. Correction Factor(dB/m) = Antenna Factor(dB/m) + Cable Factor(dB) – Pre-Amplifier Factor(dB)
3. The other emission levels were very low against the limit.
4. Margin value = Emission Level – Limit value
5. " * ": Fundamental frequency.
6. " # ": The radiated frequency is out of the restricted band.

CHANNEL	TX Channel 140	DETECTOR FUNCTION	Peak (PK)
FREQUENCY RANGE	1GHz ~ 40GHz		Average (AV)

ANTENNA POLARITY & TEST DISTANCE: HORIZONTAL AT 3 M

NO.	FREQ. (MHz)	EMISSION LEVEL (dBuV/m)	LIMIT (dBuV/m)	MARGIN (dB)	ANTENNA HEIGHT (m)	TABLE ANGLE (Degree)	RAW VALUE (dBuV)	CORRECTION FACTOR (dB/m)
1	*5700.00	114.8 PK			1.15 H	96	108.73	6.07
2	*5700.00	104.6 AV			1.15 H	96	98.53	6.07
3	#5725.00	66.1 PK	74.0	-7.9	1.15 H	96	59.96	6.14
4	#5725.00	51.5 AV	54.0	-2.5	1.15 H	96	45.36	6.14
5	11400.00	59.1 PK	74.0	-14.9	1.15 H	79	41.93	17.17
6	11400.00	46.2 AV	54.0	-7.8	1.15 H	79	29.03	17.17
7	#17100.00	55.2 PK	74.0	-18.8	1.29 H	121	33.39	21.81
8	#17100.00	42.4 AV	54.0	-11.6	1.29 H	121	20.59	21.81

ANTENNA POLARITY & TEST DISTANCE: VERTICAL AT 3 M

NO.	FREQ. (MHz)	EMISSION LEVEL (dBuV/m)	LIMIT (dBuV/m)	MARGIN (dB)	ANTENNA HEIGHT (m)	TABLE ANGLE (Degree)	RAW VALUE (dBuV)	CORRECTION FACTOR (dB/m)
1	*5700.00	117.2 PK			1.00 V	265	111.13	6.07
2	*5700.00	107.7 AV			1.00 V	265	101.63	6.07
3	#5725.00	68.4 PK	74.0	-5.6	1.00 V	265	62.26	6.14
4	#5725.00	53.8 AV	54.0	-0.2	1.00 V	265	47.66	6.14
5	11400.00	61.3 PK	74.0	-12.7	1.00 V	2	44.13	17.17
6	11400.00	48.4 AV	54.0	-5.6	1.00 V	2	31.23	17.17
7	#17100.00	55.3 PK	74.0	-18.7	1.35 V	35	33.49	21.81
8	#17100.00	41.8 AV	54.0	-12.2	1.35 V	35	19.99	21.81

REMARKS:

1. Emission Level(dBuV/m) = Raw Value(dBuV) + Correction Factor(dB/m)
2. Correction Factor(dB/m) = Antenna Factor(dB/m) + Cable Factor(dB) – Pre-Amplifier Factor(dB)
3. The other emission levels were very low against the limit.
4. Margin value = Emission Level – Limit value
5. " * ": Fundamental frequency.
6. " # ": The radiated frequency is out of the restricted band.

802.11ac (VHT20)

CHANNEL	TX Channel 52	DETECTOR FUNCTION	Peak (PK)
FREQUENCY RANGE	1GHz ~ 40GHz		Average (AV)

ANTENNA POLARITY & TEST DISTANCE: HORIZONTAL AT 3 M								
NO.	FREQ. (MHz)	EMISSION LEVEL (dBuV/m)	LIMIT (dBuV/m)	MARGIN (dB)	ANTENNA HEIGHT (m)	TABLE ANGLE (Degree)	RAW VALUE (dBuV)	CORRECTION FACTOR (dB/m)
1	5100.00	57.0 PK	74.0	-17.0	1.20 H	122	52.08	4.92
2	5100.00	44.9 AV	54.0	-9.1	1.20 H	122	39.98	4.92
3	*5260.00	116.3 PK			1.20 H	122	111.15	5.15
4	*5260.00	105.4 AV			1.20 H	122	100.25	5.15
5	#10520.00	66.5 PK	74.0	-7.5	1.16 H	109	50.18	16.32
6	#10520.00	51.5 AV	54.0	-2.5	1.16 H	109	35.18	16.32
7	15780.00	55.5 PK	74.0	-18.5	1.32 H	121	38.40	17.10
8	15780.00	42.5 AV	54.0	-11.5	1.32 H	121	25.40	17.10

ANTENNA POLARITY & TEST DISTANCE: VERTICAL AT 3 M								
NO.	FREQ. (MHz)	EMISSION LEVEL (dBuV/m)	LIMIT (dBuV/m)	MARGIN (dB)	ANTENNA HEIGHT (m)	TABLE ANGLE (Degree)	RAW VALUE (dBuV)	CORRECTION FACTOR (dB/m)
1	5100.00	59.2 PK	74.0	-14.8	1.64 V	188	54.28	4.92
2	5100.00	47.0 AV	54.0	-7.0	1.64 V	188	42.08	4.92
3	*5260.00	118.7 PK			1.63 V	182	113.55	5.15
4	*5260.00	108.5 AV			1.63 V	182	103.35	5.15
5	#10520.00	68.8 PK	74.0	-5.2	1.00 V	132	52.48	16.32
6	#10520.00	53.8 AV	54.0	-0.2	1.00 V	132	37.48	16.32
7	15780.00	55.8 PK	74.0	-18.2	1.33 V	40	38.70	17.10
8	15780.00	42.3 AV	54.0	-11.7	1.33 V	40	25.20	17.10

REMARKS:

1. Emission Level(dBuV/m) = Raw Value(dBuV) + Correction Factor(dB/m)
2. Correction Factor(dB/m) = Antenna Factor(dB/m) + Cable Factor(dB) – Pre-Amplifier Factor(dB)
3. The other emission levels were very low against the limit.
4. Margin value = Emission Level – Limit value
5. " * ": Fundamental frequency.
6. " # ": The radiated frequency is out of the restricted band.



CHANNEL	TX Channel 60	DETECTOR FUNCTION	Peak (PK)
FREQUENCY RANGE	1GHz ~ 40GHz		Average (AV)

ANTENNA POLARITY & TEST DISTANCE: HORIZONTAL AT 3 M

NO.	FREQ. (MHz)	EMISSION LEVEL (dBuV/m)	LIMIT (dBuV/m)	MARGIN (dB)	ANTENNA HEIGHT (m)	TABLE ANGLE (Degree)	RAW VALUE (dBuV)	CORRECTION FACTOR (dB/m)
1	*5300.00	116.1 PK			1.22 H	131	110.88	5.22
2	*5300.00	105.1 AV			1.22 H	131	99.88	5.22
3	10600.00	65.9 PK	74.0	-8.1	1.12 H	79	49.45	16.45
4	10600.00	51.4 AV	54.0	-2.6	1.12 H	79	34.95	16.45
5	15900.00	55.1 PK	74.0	-18.9	1.25 H	98	38.54	16.56
6	15900.00	42.4 AV	54.0	-11.6	1.25 H	98	25.84	16.56

ANTENNA POLARITY & TEST DISTANCE: VERTICAL AT 3 M

NO.	FREQ. (MHz)	EMISSION LEVEL (dBuV/m)	LIMIT (dBuV/m)	MARGIN (dB)	ANTENNA HEIGHT (m)	TABLE ANGLE (Degree)	RAW VALUE (dBuV)	CORRECTION FACTOR (dB/m)
1	*5300.00	118.5 PK			1.53 V	158	113.28	5.22
2	*5300.00	108.2 AV			1.53 V	158	102.98	5.22
3	10600.00	68.1 PK	74.0	-5.9	1.00 V	189	51.65	16.45
4	10600.00	53.6 AV	54.0	-0.4	1.00 V	189	37.15	16.45
5	15900.00	56.3 PK	74.0	-17.7	1.27 V	51	39.74	16.56
6	15900.00	42.7 AV	54.0	-11.3	1.27 V	51	26.14	16.56

REMARKS:

1. Emission Level(dBuV/m) = Raw Value(dBuV) + Correction Factor(dB/m)
2. Correction Factor(dB/m) = Antenna Factor(dB/m) + Cable Factor(dB) – Pre-Amplifier Factor(dB)
3. The other emission levels were very low against the limit.
4. Margin value = Emission Level – Limit value
5. " * ": Fundamental frequency.



CHANNEL	TX Channel 64	DETECTOR FUNCTION	Peak (PK)
FREQUENCY RANGE	1GHz ~ 40GHz		Average (AV)

ANTENNA POLARITY & TEST DISTANCE: HORIZONTAL AT 3 M

NO.	FREQ. (MHz)	EMISSION LEVEL (dBuV/m)	LIMIT (dBuV/m)	MARGIN (dB)	ANTENNA HEIGHT (m)	TABLE ANGLE (Degree)	RAW VALUE (dBuV)	CORRECTION FACTOR (dB/m)
1	*5320.00	116.9 PK			1.18 H	101	111.62	5.28
2	*5320.00	106.0 AV			1.18 H	101	100.72	5.28
3	5350.00	66.5 PK	74.0	-7.5	1.18 H	101	61.14	5.36
4	5350.00	51.1 AV	54.0	-2.9	1.18 H	101	45.74	5.36
5	10640.00	63.5 PK	74.0	-10.5	1.29 H	111	47.17	16.33
6	10640.00	49.8 AV	54.0	-4.2	1.29 H	111	33.47	16.33
7	15960.00	55.4 PK	74.0	-18.6	1.25 H	97	38.70	16.70
8	15960.00	42.4 AV	54.0	-11.6	1.25 H	97	25.70	16.70

ANTENNA POLARITY & TEST DISTANCE: VERTICAL AT 3 M

NO.	FREQ. (MHz)	EMISSION LEVEL (dBuV/m)	LIMIT (dBuV/m)	MARGIN (dB)	ANTENNA HEIGHT (m)	TABLE ANGLE (Degree)	RAW VALUE (dBuV)	CORRECTION FACTOR (dB/m)
1	*5320.00	119.3 PK			1.61 V	158	114.02	5.28
2	*5320.00	109.2 AV			1.61 V	158	103.92	5.28
3	5350.00	68.8 PK	74.0	-5.2	1.61 V	158	63.44	5.36
4	5350.00	53.6 AV	54.0	-0.4	1.61 V	158	48.24	5.36
5	10640.00	65.8 PK	74.0	-8.2	1.00 V	190	49.47	16.33
6	10640.00	52.1 AV	54.0	-1.9	1.00 V	190	35.77	16.33
7	15960.00	56.0 PK	74.0	-18.0	1.37 V	49	39.30	16.70
8	15960.00	42.4 AV	54.0	-11.6	1.37 V	49	25.70	16.70

REMARKS:

1. Emission Level(dBuV/m) = Raw Value(dBuV) + Correction Factor(dB/m)
2. Correction Factor(dB/m) = Antenna Factor(dB/m) + Cable Factor(dB) – Pre-Amplifier Factor(dB)
3. The other emission levels were very low against the limit.
4. Margin value = Emission Level – Limit value
5. " * ": Fundamental frequency.

CHANNEL	TX Channel 100	DETECTOR FUNCTION	Peak (PK)
FREQUENCY RANGE	1GHz ~ 40GHz		Average (AV)

ANTENNA POLARITY & TEST DISTANCE: HORIZONTAL AT 3 M

NO.	FREQ. (MHz)	EMISSION LEVEL (dBuV/m)	LIMIT (dBuV/m)	MARGIN (dB)	ANTENNA HEIGHT (m)	TABLE ANGLE (Degree)	RAW VALUE (dBuV)	CORRECTION FACTOR (dB/m)
1	5460.00	61.2 PK	74.0	-12.8	1.22 H	109	55.58	5.62
2	5460.00	46.5 AV	54.0	-7.5	1.22 H	109	40.88	5.62
3	#5468.00	70.5 PK	74.0	-3.5	1.22 H	109	64.86	5.64
4	#5468.00	51.3 AV	54.0	-2.7	1.22 H	109	45.66	5.64
5	*5500.00	117.0 PK			1.22 H	109	111.30	5.70
6	*5500.00	106.2 AV			1.22 H	109	100.50	5.70
7	11000.00	58.8 PK	74.0	-15.2	1.24 H	158	41.62	17.18
8	11000.00	47.2 AV	54.0	-6.8	1.24 H	158	30.02	17.18
9	#16500.00	54.4 PK	74.0	-19.6	1.29 H	103	34.86	19.54
10	#16500.00	41.7 AV	54.0	-12.3	1.29 H	103	22.16	19.54

ANTENNA POLARITY & TEST DISTANCE: VERTICAL AT 3 M

NO.	FREQ. (MHz)	EMISSION LEVEL (dBuV/m)	LIMIT (dBuV/m)	MARGIN (dB)	ANTENNA HEIGHT (m)	TABLE ANGLE (Degree)	RAW VALUE (dBuV)	CORRECTION FACTOR (dB/m)
1	5460.00	63.4 PK	74.0	-10.6	1.00 V	94	57.78	5.62
2	5460.00	48.7 AV	54.0	-5.3	1.00 V	94	43.08	5.62
3	#5468.00	72.8 PK	74.0	-1.2	1.00 V	94	67.16	5.64
4	#5468.00	53.7 AV	54.0	-0.3	1.00 V	94	48.06	5.64
5	*5500.00	119.3 PK			1.00 V	94	113.60	5.70
6	*5500.00	109.2 AV			1.00 V	94	103.50	5.70
7	11000.00	61.5 PK	74.0	-12.5	1.00 V	7	44.32	17.18
8	11000.00	49.4 AV	54.0	-4.6	1.00 V	7	32.22	17.18
9	#16500.00	55.7 PK	74.0	-18.3	1.33 V	63	36.16	19.54
10	#16500.00	42.5 AV	54.0	-11.5	1.33 V	63	22.96	19.54

REMARKS:

- Emission Level(dBuV/m) = Raw Value(dBuV) + Correction Factor(dB/m)
- Correction Factor(dB/m) = Antenna Factor(dB/m) + Cable Factor(dB) – Pre-Amplifier Factor(dB)
- The other emission levels were very low against the limit.
- Margin value = Emission Level – Limit value
- " * ": Fundamental frequency.
- " # ": The radiated frequency is out of the restricted band.



CHANNEL	TX Channel 116	DETECTOR FUNCTION	Peak (PK)
FREQUENCY RANGE	1GHz ~ 40GHz		Average (AV)

ANTENNA POLARITY & TEST DISTANCE: HORIZONTAL AT 3 M

NO.	FREQ. (MHz)	EMISSION LEVEL (dBuV/m)	LIMIT (dBuV/m)	MARGIN (dB)	ANTENNA HEIGHT (m)	TABLE ANGLE (Degree)	RAW VALUE (dBuV)	CORRECTION FACTOR (dB/m)
1	*5580.00	117.7 PK			1.16 H	110	111.93	5.77
2	*5580.00	107.0 AV			1.16 H	110	101.23	5.77
3	#5740.00	65.2 PK	68.2	-3.0	1.16 H	110	59.01	6.19
4	11160.00	60.1 PK	74.0	-13.9	1.29 H	48	42.93	17.17
5	11160.00	47.8 AV	54.0	-6.2	1.29 H	48	30.63	17.17
6	#16740.00	54.5 PK	68.2	-13.7	1.29 H	97	34.82	19.68

ANTENNA POLARITY & TEST DISTANCE: VERTICAL AT 3 M

NO.	FREQ. (MHz)	EMISSION LEVEL (dBuV/m)	LIMIT (dBuV/m)	MARGIN (dB)	ANTENNA HEIGHT (m)	TABLE ANGLE (Degree)	RAW VALUE (dBuV)	CORRECTION FACTOR (dB/m)
1	*5580.00	120.0 PK			1.00 V	283	114.23	5.77
2	*5580.00	109.7 AV			1.00 V	283	103.93	5.77
3	#5740.00	67.8 PK	68.2	-0.4	1.00 V	93	61.61	6.19
4	11160.00	62.3 PK	74.0	-11.7	1.00 V	15	45.13	17.17
5	11160.00	50.0 AV	54.0	-4.0	1.00 V	15	32.83	17.17
6	#16740.00	55.3 PK	68.2	-12.9	1.32 V	54	35.62	19.68

REMARKS:

1. Emission Level(dBuV/m) = Raw Value(dBuV) + Correction Factor(dB/m)
2. Correction Factor(dB/m) = Antenna Factor(dB/m) + Cable Factor(dB) – Pre-Amplifier Factor(dB)
3. The other emission levels were very low against the limit.
4. Margin value = Emission Level – Limit value
5. " * ": Fundamental frequency.
6. " # ": The radiated frequency is out of the restricted band.



CHANNEL	TX Channel 140	DETECTOR FUNCTION	Peak (PK)
FREQUENCY RANGE	1GHz ~ 40GHz		Average (AV)

ANTENNA POLARITY & TEST DISTANCE: HORIZONTAL AT 3 M

NO.	FREQ. (MHz)	EMISSION LEVEL (dBuV/m)	LIMIT (dBuV/m)	MARGIN (dB)	ANTENNA HEIGHT (m)	TABLE ANGLE (Degree)	RAW VALUE (dBuV)	CORRECTION FACTOR (dB/m)
1	*5700.00	116.6 PK			1.17 H	105	110.53	6.07
2	*5700.00	105.6 AV			1.17 H	105	99.53	6.07
3	#5725.00	67.1 PK	74.0	-6.9	1.17 H	105	60.96	6.14
4	#5725.00	51.5 AV	54.0	-2.5	1.17 H	105	45.36	6.14
5	11400.00	58.5 PK	74.0	-15.5	1.26 H	79	41.33	17.17
6	11400.00	46.8 AV	54.0	-7.2	1.26 H	79	29.63	17.17
7	#17100.00	55.8 PK	74.0	-18.2	1.23 H	97	33.99	21.81
8	#17100.00	42.5 AV	54.0	-11.5	1.23 H	97	20.69	21.81

ANTENNA POLARITY & TEST DISTANCE: VERTICAL AT 3 M

NO.	FREQ. (MHz)	EMISSION LEVEL (dBuV/m)	LIMIT (dBuV/m)	MARGIN (dB)	ANTENNA HEIGHT (m)	TABLE ANGLE (Degree)	RAW VALUE (dBuV)	CORRECTION FACTOR (dB/m)
1	*5700.00	119.0 PK			1.00 V	88	112.93	6.07
2	*5700.00	108.2 AV			1.00 V	88	102.13	6.07
3	#5725.00	69.4 PK	74.0	-4.6	1.00 V	88	63.26	6.14
4	#5725.00	53.8 AV	54.0	-0.2	1.00 V	88	47.66	6.14
5	11400.00	60.9 PK	74.0	-13.1	1.00 V	6	43.73	17.17
6	11400.00	49.0 AV	54.0	-5.0	1.00 V	6	31.83	17.17
7	#17100.00	55.0 PK	74.0	-19.0	1.30 V	43	33.19	21.81
8	#17100.00	41.9 AV	54.0	-12.1	1.30 V	43	20.09	21.81

REMARKS:

1. Emission Level(dBuV/m) = Raw Value(dBuV) + Correction Factor(dB/m)
2. Correction Factor(dB/m) = Antenna Factor(dB/m) + Cable Factor(dB) – Pre-Amplifier Factor(dB)
3. The other emission levels were very low against the limit.
4. Margin value = Emission Level – Limit value
5. " * ": Fundamental frequency.
6. " # ": The radiated frequency is out of the restricted band.

802.11ac (VHT40)

CHANNEL	TX Channel 54	DETECTOR FUNCTION	Peak (PK)
FREQUENCY RANGE	1GHz ~ 40GHz		Average (AV)

ANTENNA POLARITY & TEST DISTANCE: HORIZONTAL AT 3 M								
NO.	FREQ. (MHz)	EMISSION LEVEL (dBuV/m)	LIMIT (dBuV/m)	MARGIN (dB)	ANTENNA HEIGHT (m)	TABLE ANGLE (Degree)	RAW VALUE (dBuV)	CORRECTION FACTOR (dB/m)
1	5110.00	62.3 PK	74.0	-11.7	1.15 H	100	57.37	4.93
2	5110.00	51.5 AV	54.0	-2.5	1.15 H	100	46.57	4.93
3	*5270.00	113.6 PK			1.15 H	100	108.44	5.16
4	*5270.00	104.0 AV			1.15 H	100	98.84	5.16
5	#10540.00	64.8 PK	74.0	-9.2	1.18 H	95	48.45	16.35
6	#10540.00	50.1 AV	54.0	-3.9	1.18 H	95	33.75	16.35
7	15810.00	55.4 PK	74.0	-18.6	1.31 H	115	38.49	16.91
8	15810.00	42.5 AV	54.0	-11.5	1.31 H	115	25.59	16.91

ANTENNA POLARITY & TEST DISTANCE: VERTICAL AT 3 M								
NO.	FREQ. (MHz)	EMISSION LEVEL (dBuV/m)	LIMIT (dBuV/m)	MARGIN (dB)	ANTENNA HEIGHT (m)	TABLE ANGLE (Degree)	RAW VALUE (dBuV)	CORRECTION FACTOR (dB/m)
1	5110.00	64.8 PK	74.0	-9.2	1.48 V	134	59.87	4.93
2	5110.00	53.8 AV	54.0	-0.2	1.48 V	134	48.87	4.93
3	*5270.00	116.2 PK			1.48 V	183	111.04	5.16
4	*5270.00	106.6 AV			1.48 V	183	101.44	5.16
5	#10540.00	67.1 PK	74.0	-6.9	1.00 V	134	50.75	16.35
6	#10540.00	52.4 AV	54.0	-1.6	1.00 V	134	36.05	16.35
7	15810.00	55.4 PK	74.0	-18.6	1.27 V	63	38.49	16.91
8	15810.00	41.9 AV	54.0	-12.1	1.27 V	63	24.99	16.91

REMARKS:

- Emission Level(dBuV/m) = Raw Value(dBuV) + Correction Factor(dB/m)
- Correction Factor(dB/m) = Antenna Factor(dB/m) + Cable Factor(dB) – Pre-Amplifier Factor(dB)
- The other emission levels were very low against the limit.
- Margin value = Emission Level – Limit value
- " * ": Fundamental frequency.
- " # ": The radiated frequency is out of the restricted band.



CHANNEL	TX Channel 62	DETECTOR FUNCTION	Peak (PK)
FREQUENCY RANGE	1GHz ~ 40GHz		Average (AV)

ANTENNA POLARITY & TEST DISTANCE: HORIZONTAL AT 3 M

NO.	FREQ. (MHz)	EMISSION LEVEL (dBuV/m)	LIMIT (dBuV/m)	MARGIN (dB)	ANTENNA HEIGHT (m)	TABLE ANGLE (Degree)	RAW VALUE (dBuV)	CORRECTION FACTOR (dB/m)
1	*5310.00	110.6 PK			1.19 H	106	105.35	5.25
2	*5310.00	100.5 AV			1.19 H	106	95.25	5.25
3	5350.00	65.6 PK	74.0	-8.4	1.19 H	106	60.24	5.36
4	5350.00	51.6 AV	54.0	-2.4	1.19 H	106	46.24	5.36
5	10620.00	63.2 PK	74.0	-10.8	1.22 H	88	46.81	16.39
6	10620.00	49.6 AV	54.0	-4.4	1.22 H	88	33.21	16.39
7	15930.00	55.5 PK	74.0	-18.5	1.31 H	118	38.86	16.64
8	15930.00	42.2 AV	54.0	-11.8	1.31 H	118	25.56	16.64

ANTENNA POLARITY & TEST DISTANCE: VERTICAL AT 3 M

NO.	FREQ. (MHz)	EMISSION LEVEL (dBuV/m)	LIMIT (dBuV/m)	MARGIN (dB)	ANTENNA HEIGHT (m)	TABLE ANGLE (Degree)	RAW VALUE (dBuV)	CORRECTION FACTOR (dB/m)
1	*5310.00	113.4 PK			1.59 V	156	108.15	5.25
2	*5310.00	103.1 AV			1.59 V	156	97.85	5.25
3	5350.00	68.0 PK	74.0	-6.0	1.59 V	156	62.64	5.36
4	5350.00	53.8 AV	54.0	-0.2	1.59 V	156	48.44	5.36
5	10620.00	65.5 PK	74.0	-8.5	1.00 V	196	49.11	16.39
6	10620.00	51.9 AV	54.0	-2.1	1.00 V	196	35.51	16.39
7	15930.00	56.1 PK	74.0	-17.9	1.37 V	35	39.46	16.64
8	15930.00	42.8 AV	54.0	-11.2	1.37 V	35	26.16	16.64

REMARKS:

1. Emission Level(dBuV/m) = Raw Value(dBuV) + Correction Factor(dB/m)
2. Correction Factor(dB/m) = Antenna Factor(dB/m) + Cable Factor(dB) – Pre-Amplifier Factor(dB)
3. The other emission levels were very low against the limit.
4. Margin value = Emission Level – Limit value
5. " * ": Fundamental frequency.

CHANNEL	TX Channel 102	DETECTOR FUNCTION	Peak (PK)
FREQUENCY RANGE	1GHz ~ 40GHz		Average (AV)

ANTENNA POLARITY & TEST DISTANCE: HORIZONTAL AT 3 M

NO.	FREQ. (MHz)	EMISSION LEVEL (dBuV/m)	LIMIT (dBuV/m)	MARGIN (dB)	ANTENNA HEIGHT (m)	TABLE ANGLE (Degree)	RAW VALUE (dBuV)	CORRECTION FACTOR (dB/m)
1	5460.00	64.8 PK	74.0	-9.2	1.20 H	111	59.18	5.62
2	5460.00	48.2 AV	54.0	-5.8	1.20 H	111	42.58	5.62
3	#5468.00	69.8 PK	74.0	-4.2	1.20 H	111	64.16	5.64
4	#5468.00	51.4 AV	54.0	-2.6	1.20 H	111	45.76	5.64
5	*5510.00	112.6 PK			1.20 H	111	106.89	5.71
6	*5510.00	101.8 AV			1.20 H	111	96.09	5.71
7	11020.00	50.9 PK	74.0	-23.1	1.17 H	80	33.63	17.27
8	11020.00	48.9 AV	54.0	-5.1	1.17 H	80	31.63	17.27
9	#16530.00	55.0 PK	74.0	-19.0	1.25 H	104	35.45	19.55
10	#16530.00	41.8 AV	54.0	-12.2	1.25 H	104	22.25	19.55

ANTENNA POLARITY & TEST DISTANCE: VERTICAL AT 3 M

NO.	FREQ. (MHz)	EMISSION LEVEL (dBuV/m)	LIMIT (dBuV/m)	MARGIN (dB)	ANTENNA HEIGHT (m)	TABLE ANGLE (Degree)	RAW VALUE (dBuV)	CORRECTION FACTOR (dB/m)
1	5460.00	67.0 PK	74.0	-7.0	1.00 V	90	61.38	5.62
2	5460.00	50.4 AV	54.0	-3.6	1.00 V	90	44.78	5.62
3	#5468.00	72.1 PK	74.0	-1.9	1.00 V	90	66.46	5.64
4	#5468.00	53.8 AV	54.0	-0.2	1.00 V	90	48.16	5.64
5	*5510.00	115.4 PK			1.00 V	90	109.69	5.71
6	*5510.00	104.5 AV			1.00 V	90	98.79	5.71
7	11020.00	51.2 PK	74.0	-22.8	1.00 V	4	33.93	17.27
8	11020.00	49.2 AV	54.0	-4.8	1.00 V	4	31.93	17.27
9	#16530.00	56.1 PK	74.0	-17.9	1.32 V	60	36.55	19.55
10	#16530.00	42.7 AV	54.0	-11.3	1.32 V	60	23.15	19.55

REMARKS:

- Emission Level(dBuV/m) = Raw Value(dBuV) + Correction Factor(dB/m)
- Correction Factor(dB/m) = Antenna Factor(dB/m) + Cable Factor(dB) – Pre-Amplifier Factor(dB)
- The other emission levels were very low against the limit.
- Margin value = Emission Level – Limit value
- " * ": Fundamental frequency.
- " # ": The radiated frequency is out of the restricted band.



CHANNEL	TX Channel 110	DETECTOR FUNCTION	Peak (PK)
FREQUENCY RANGE	1GHz ~ 40GHz		Average (AV)

ANTENNA POLARITY & TEST DISTANCE: HORIZONTAL AT 3 M

NO.	FREQ. (MHz)	EMISSION LEVEL (dBuV/m)	LIMIT (dBuV/m)	MARGIN (dB)	ANTENNA HEIGHT (m)	TABLE ANGLE (Degree)	RAW VALUE (dBuV)	CORRECTION FACTOR (dB/m)
1	*5550.00	116.8 PK			1.14 H	91	111.06	5.74
2	*5550.00	105.8 AV			1.14 H	91	100.06	5.74
3	#5790.00	61.1 PK	74.0	-12.9	1.14 H	91	54.76	6.34
4	#5790.00	49.7 AV	54.0	-4.3	1.14 H	91	43.36	6.34
5	11100.00	51.1 PK	74.0	-22.9	1.22 H	95	33.45	17.65
6	11100.00	49.2 AV	54.0	-4.8	1.22 H	95	31.55	17.65
7	#16650.00	55.5 PK	74.0	-18.5	1.29 H	113	35.93	19.57
8	#16650.00	42.5 AV	54.0	-11.5	1.29 H	113	22.93	19.57

ANTENNA POLARITY & TEST DISTANCE: VERTICAL AT 3 M

NO.	FREQ. (MHz)	EMISSION LEVEL (dBuV/m)	LIMIT (dBuV/m)	MARGIN (dB)	ANTENNA HEIGHT (m)	TABLE ANGLE (Degree)	RAW VALUE (dBuV)	CORRECTION FACTOR (dB/m)
1	*5550.00	119.6 PK			1.00 V	89	113.86	5.74
2	*5550.00	108.5 AV			1.00 V	89	102.76	5.74
3	#5790.00	63.7 PK	74.0	-10.3	1.00 V	91	57.36	6.34
4	#5790.00	52.0 AV	54.0	-2.0	1.00 V	91	45.66	6.34
5	11100.00	51.5 PK	74.0	-22.5	1.00 V	10	33.85	17.65
6	11100.00	49.8 AV	54.0	-4.2	1.00 V	10	32.15	17.65
7	#16650.00	55.5 PK	74.0	-18.5	1.33 V	56	35.93	19.57
8	#16650.00	42.4 AV	54.0	-11.6	1.33 V	56	22.83	19.57

REMARKS:

1. Emission Level(dBuV/m) = Raw Value(dBuV) + Correction Factor(dB/m)
2. Correction Factor(dB/m) = Antenna Factor(dB/m) + Cable Factor(dB) – Pre-Amplifier Factor(dB)
3. The other emission levels were very low against the limit.
4. Margin value = Emission Level – Limit value
5. " * ": Fundamental frequency.
6. " # ": The radiated frequency is out of the restricted band.

CHANNEL	TX Channel 134	DETECTOR FUNCTION	Peak (PK)
FREQUENCY RANGE	1GHz ~ 40GHz		Average (AV)

ANTENNA POLARITY & TEST DISTANCE: HORIZONTAL AT 3 M

NO.	FREQ. (MHz)	EMISSION LEVEL (dBuV/m)	LIMIT (dBuV/m)	MARGIN (dB)	ANTENNA HEIGHT (m)	TABLE ANGLE (Degree)	RAW VALUE (dBuV)	CORRECTION FACTOR (dB/m)
1	*5670.00	114.9 PK			1.18 H	72	108.93	5.97
2	*5670.00	104.5 AV			1.18 H	72	98.53	5.97
3	#5725.00	66.0 PK	74.0	-8.0	1.18 H	72	59.86	6.14
4	#5725.00	51.4 AV	54.0	-2.6	1.18 H	72	45.26	6.14
5	11340.00	58.4 PK	74.0	-15.6	1.11 H	75	41.17	17.23
6	11340.00	46.2 AV	54.0	-7.8	1.11 H	75	28.97	17.23
7	#17010.00	55.3 PK	74.0	-18.7	1.34 H	124	33.66	21.64
8	#17010.00	42.3 AV	54.0	-11.7	1.34 H	124	20.66	21.64

ANTENNA POLARITY & TEST DISTANCE: VERTICAL AT 3 M

NO.	FREQ. (MHz)	EMISSION LEVEL (dBuV/m)	LIMIT (dBuV/m)	MARGIN (dB)	ANTENNA HEIGHT (m)	TABLE ANGLE (Degree)	RAW VALUE (dBuV)	CORRECTION FACTOR (dB/m)
1	*5670.00	117.5 PK			1.61 V	305	111.53	5.97
2	*5670.00	107.3 AV			1.61 V	305	101.33	5.97
3	#5725.00	68.4 PK	74.0	-5.6	1.61 V	305	62.26	6.14
4	#5725.00	53.8 AV	54.0	-0.2	1.61 V	305	47.66	6.14
5	11340.00	60.9 PK	74.0	-13.1	1.00 V	11	43.67	17.23
6	11340.00	48.9 AV	54.0	-5.1	1.00 V	11	31.67	17.23
7	#17010.00	54.9 PK	74.0	-19.1	1.31 V	65	33.26	21.64
8	#17010.00	41.8 AV	54.0	-12.2	1.31 V	65	20.16	21.64

REMARKS:

1. Emission Level(dBuV/m) = Raw Value(dBuV) + Correction Factor(dB/m)
2. Correction Factor(dB/m) = Antenna Factor(dB/m) + Cable Factor(dB) – Pre-Amplifier Factor(dB)
3. The other emission levels were very low against the limit.
4. Margin value = Emission Level – Limit value
5. " * ": Fundamental frequency.
6. " # ": The radiated frequency is out of the restricted band.

802.11ac (VHT80)

CHANNEL	TX Channel 58	DETECTOR FUNCTION	Peak (PK)
FREQUENCY RANGE	1GHz ~ 40GHz		Average (AV)

ANTENNA POLARITY & TEST DISTANCE: HORIZONTAL AT 3 M								
NO.	FREQ. (MHz)	EMISSION LEVEL (dBuV/m)	LIMIT (dBuV/m)	MARGIN (dB)	ANTENNA HEIGHT (m)	TABLE ANGLE (Degree)	RAW VALUE (dBuV)	CORRECTION FACTOR (dB/m)
1	*5290.00	105.8 PK			1.22 H	91	100.60	5.20
2	*5290.00	95.8 AV			1.22 H	91	90.60	5.20
3	5350.00	64.8 PK	74.0	-9.2	1.22 H	91	59.44	5.36
4	5350.00	51.2 AV	54.0	-2.8	1.22 H	91	45.84	5.36
5	#10580.00	60.0 PK	74.0	-14.0	1.15 H	65	43.59	16.41
6	#10580.00	48.1 AV	54.0	-5.9	1.15 H	65	31.69	16.41
7	15870.00	54.8 PK	74.0	-19.2	1.34 H	101	38.12	16.68
8	15870.00	41.7 AV	54.0	-12.3	1.34 H	101	25.02	16.68

ANTENNA POLARITY & TEST DISTANCE: VERTICAL AT 3 M								
NO.	FREQ. (MHz)	EMISSION LEVEL (dBuV/m)	LIMIT (dBuV/m)	MARGIN (dB)	ANTENNA HEIGHT (m)	TABLE ANGLE (Degree)	RAW VALUE (dBuV)	CORRECTION FACTOR (dB/m)
1	*5290.00	108.4 PK			1.54 V	196	103.20	5.20
2	*5290.00	98.6 AV			1.54 V	196	93.40	5.20
3	5350.00	67.0 PK	74.0	-7.0	1.54 V	196	61.64	5.36
4	5350.00	53.8 AV	54.0	-0.2	1.54 V	196	48.44	5.36
5	#10580.00	64.2 PK	74.0	-9.8	1.00 V	190	47.79	16.41
6	#10580.00	50.4 AV	54.0	-3.6	1.00 V	190	33.99	16.41
7	15870.00	55.6 PK	74.0	-18.4	1.26 V	49	38.92	16.68
8	15870.00	42.4 AV	54.0	-11.6	1.26 V	49	25.72	16.68

REMARKS:

1. Emission Level(dBuV/m) = Raw Value(dBuV) + Correction Factor(dB/m)
2. Correction Factor(dB/m) = Antenna Factor(dB/m) + Cable Factor(dB) – Pre-Amplifier Factor(dB)
3. The other emission levels were very low against the limit.
4. Margin value = Emission Level – Limit value
5. " * ": Fundamental frequency.
6. " # ": The radiated frequency is out of the restricted band.

CHANNEL	TX Channel 106	DETECTOR FUNCTION	Peak (PK)
FREQUENCY RANGE	1GHz ~ 40GHz		Average (AV)

ANTENNA POLARITY & TEST DISTANCE: HORIZONTAL AT 3 M

NO.	FREQ. (MHz)	EMISSION LEVEL (dBuV/m)	LIMIT (dBuV/m)	MARGIN (dB)	ANTENNA HEIGHT (m)	TABLE ANGLE (Degree)	RAW VALUE (dBuV)	CORRECTION FACTOR (dB/m)
1	5460.00	63.1 PK	74.0	-10.9	1.19 H	86	57.48	5.62
2	5460.00	49.9 AV	54.0	-4.1	1.19 H	86	44.28	5.62
3	#5468.00	66.0 PK	74.0	-8.0	1.19 H	86	60.36	5.64
4	#5468.00	51.6 AV	54.0	-2.4	1.19 H	86	45.96	5.64
5	*5530.00	109.7 PK			1.19 H	86	103.98	5.72
6	*5530.00	98.4 AV			1.19 H	86	92.68	5.72
7	11060.00	58.5 PK	74.0	-15.5	1.13 H	88	41.04	17.46
8	11060.00	46.7 AV	54.0	-7.3	1.13 H	88	29.24	17.46
9	#16590.00	55.3 PK	74.0	-18.7	1.24 H	106	35.74	19.56
10	#16590.00	42.4 AV	54.0	-11.6	1.24 H	106	22.84	19.56

ANTENNA POLARITY & TEST DISTANCE: VERTICAL AT 3 M

NO.	FREQ. (MHz)	EMISSION LEVEL (dBuV/m)	LIMIT (dBuV/m)	MARGIN (dB)	ANTENNA HEIGHT (m)	TABLE ANGLE (Degree)	RAW VALUE (dBuV)	CORRECTION FACTOR (dB/m)
1	5460.00	65.3 PK	74.0	-8.7	1.04 V	323	59.68	5.62
2	5460.00	52.1 AV	54.0	-1.9	1.04 V	323	46.48	5.62
3	#5468.00	68.4 PK	74.0	-5.6	1.04 V	323	62.76	5.64
4	#5468.00	53.8 AV	54.0	-0.2	1.04 V	323	48.16	5.64
5	*5530.00	112.3 PK			1.04 V	323	106.58	5.72
6	*5530.00	101.4 AV			1.04 V	323	95.68	5.72
7	11060.00	60.8 PK	74.0	-13.2	1.00 V	12	43.34	17.46
8	11060.00	49.0 AV	54.0	-5.0	1.00 V	12	31.54	17.46
9	#16590.00	55.5 PK	74.0	-18.5	1.34 V	59	35.94	19.56
10	#16590.00	42.4 AV	54.0	-11.6	1.34 V	59	22.84	19.56

REMARKS:

- Emission Level(dBuV/m) = Raw Value(dBuV) + Correction Factor(dB/m)
- Correction Factor(dB/m) = Antenna Factor(dB/m) + Cable Factor(dB) – Pre-Amplifier Factor(dB)
- The other emission levels were very low against the limit.
- Margin value = Emission Level – Limit value
- " * ": Fundamental frequency.
- " # ": The radiated frequency is out of the restricted band.

CHANNEL	TX Channel 122	DETECTOR FUNCTION	Peak (PK)
FREQUENCY RANGE	1GHz ~ 40GHz		Average (AV)

ANTENNA POLARITY & TEST DISTANCE: HORIZONTAL AT 3 M

NO.	FREQ. (MHz)	EMISSION LEVEL (dBuV/m)	LIMIT (dBuV/m)	MARGIN (dB)	ANTENNA HEIGHT (m)	TABLE ANGLE (Degree)	RAW VALUE (dBuV)	CORRECTION FACTOR (dB/m)
1	*5610.00	106.4 PK			1.14 H	85	100.59	5.81
2	*5610.00	96.2 AV			1.14 H	85	90.39	5.81
3	#5798.00	62.2 PK	74.0	-11.8	1.14 H	85	55.84	6.36
4	#5798.00	50.6 AV	54.0	-3.4	1.14 H	85	44.24	6.36
5	11220.00	59.5 PK	74.0	-14.5	1.10 H	69	42.57	16.93
6	11220.00	47.1 AV	54.0	-6.9	1.10 H	69	30.17	16.93
7	#16830.00	55.1 PK	74.0	-18.9	1.29 H	111	35.08	20.02
8	#16830.00	42.1 AV	54.0	-11.9	1.29 H	111	22.08	20.02

ANTENNA POLARITY & TEST DISTANCE: VERTICAL AT 3 M

NO.	FREQ. (MHz)	EMISSION LEVEL (dBuV/m)	LIMIT (dBuV/m)	MARGIN (dB)	ANTENNA HEIGHT (m)	TABLE ANGLE (Degree)	RAW VALUE (dBuV)	CORRECTION FACTOR (dB/m)
1	*5610.00	109.0 PK			1.26 V	120	103.19	5.81
2	*5610.00	99.2 AV			1.26 V	120	93.39	5.81
3	#5798.00	64.4 PK	74.0	-9.6	1.26 V	120	58.04	6.36
4	#5798.00	52.9 AV	54.0	-1.1	1.26 V	120	46.54	6.36
5	11220.00	61.4 PK	74.0	-12.6	1.03 V	6	44.47	16.93
6	11220.00	49.3 AV	54.0	-4.7	1.03 V	6	32.37	16.93
7	#16830.00	55.6 PK	74.0	-18.4	1.32 V	49	35.58	20.02
8	#16830.00	42.3 AV	54.0	-11.7	1.32 V	49	22.28	20.02

REMARKS:

1. Emission Level(dBuV/m) = Raw Value(dBuV) + Correction Factor(dB/m)
2. Correction Factor(dB/m) = Antenna Factor(dB/m) + Cable Factor(dB) – Pre-Amplifier Factor(dB)
3. The other emission levels were very low against the limit.
4. Margin value = Emission Level – Limit value
5. " * ": Fundamental frequency.
6. " # ": The radiated frequency is out of the restricted band.

Below 1GHz Data
CDD Mode
802.11ac (VHT40)

CHANNEL	TX Channel 102	DETECTOR FUNCTION	Quasi-Peak (QP)
FREQUENCY RANGE	Below 1GHz		

ANTENNA POLARITY & TEST DISTANCE: HORIZONTAL AT 3 M

NO.	FREQ. (MHz)	EMISSION LEVEL (dBuV/m)	LIMIT (dBuV/m)	MARGIN (dB)	ANTENNA HEIGHT (m)	TABLE ANGLE (Degree)	RAW VALUE (dBuV)	CORRECTION FACTOR (dB/m)
1	99.99	36.3 QP	43.5	-7.2	1.50 H	360	48.56	-12.27
2	180.28	39.4 QP	43.5	-4.1	2.00 H	292	48.75	-9.31
3	227.88	39.6 QP	46.0	-6.4	1.50 H	211	50.11	-10.52
4	330.87	39.6 QP	46.0	-6.5	1.00 H	103	45.38	-5.83
5	383.23	39.1 QP	46.0	-6.9	1.00 H	145	43.63	-4.51
6	441.16	30.9 QP	46.0	-15.1	1.00 H	329	33.57	-2.68

ANTENNA POLARITY & TEST DISTANCE: VERTICAL AT 3 M

NO.	FREQ. (MHz)	EMISSION LEVEL (dBuV/m)	LIMIT (dBuV/m)	MARGIN (dB)	ANTENNA HEIGHT (m)	TABLE ANGLE (Degree)	RAW VALUE (dBuV)	CORRECTION FACTOR (dB/m)
1	107.43	35.9 QP	43.5	-7.6	1.00 V	308	46.92	-11.05
2	143.27	36.7 QP	43.5	-6.8	1.00 V	285	44.71	-7.99
3	180.88	36.7 QP	43.5	-6.8	1.00 V	211	46.06	-9.40
4	333.56	40.4 QP	46.0	-5.7	1.50 V	0	46.16	-5.81
5	352.28	39.0 QP	46.0	-7.0	1.50 V	308	44.53	-5.49
6	380.17	42.3 QP	46.0	-3.7	1.00 V	3	46.86	-4.56

REMARKS:

1. Emission Level(dBuV/m) = Raw Value(dBuV) + Correction Factor(dB/m)
2. Correction Factor(dB/m) = Antenna Factor(dB/m) + Cable Factor(dB) – Pre-Amplifier Factor(dB)
3. The other emission levels were very low against the limit.
4. Margin value = Emission Level – Limit value

4.2 Conducted Emission Measurement

4.2.1 Limits of Conducted Emission Measurement

Frequency (MHz)	Conducted Limit (dBuV)	
	Quasi-peak	Average
0.15 - 0.5	66 - 56	56 - 46
0.50 - 5.0	56	46
5.0 - 30.0	60	50

- Note: 1. The lower limit shall apply at the transition frequencies.
 2. The limit decreases in line with the logarithm of the frequency in the range of 0.15 to 0.50MHz.

4.2.2 Test Instruments

DESCRIPTION & MANUFACTURER	MODEL NO.	SERIAL NO.	CALIBRATED DATE	CALIBRATED UNTIL
Test Receiver R&S	ESCS 30	100375	May 06, 2015	May 05, 2016
Line-Impedance Stabilization Network (for EUT) SCHWARZBECK	NSLK-8127	8127-522	Sep. 01, 2015	Aug. 31, 2016
Line-Impedance Stabilization Network (for Peripheral) R&S	ENV216	100072	June 11, 2015	June 10, 2016
RF Cable	5D-FB	COCCAB-001	Mar. 09, 2015	Mar. 08, 2016
50 ohms Terminator	N/A	EMC-03	Sep. 23, 2015	Sep. 22, 2016
50 ohms Terminator	N/A	EMC-02	Oct. 01, 2015	Sep. 30, 2016
Software BVADT	BVADT_Cond_ V7.3.7.3	NA	NA	NA

Note:

1. The calibration interval of the above test instruments are 12 months and the calibrations are traceable to NML/ROC and NIST/USA.
2. The test was performed in Shielded Room No. C.
3. The VCCI Con C Registration No. is C-3611.
4. Tested Date: Jan. 21, 2016

4.2.3 Test Procedure

- a. The EUT was placed 0.4 meters from the conducting wall of the shielded room with EUT being connected to the power mains through a line impedance stabilization network (LISN). Other support units were connected to the power mains through another LISN. The two LISNs provide 50 ohm/ 50uH of coupling impedance for the measuring instrument.
- b. Both lines of the power mains connected to the EUT were checked for maximum conducted interference.
- c. The frequency range from 150kHz to 30MHz was searched. Emission levels under (Limit - 20dB) was not recorded.

NOTE: All modes of operation were investigated and the worst-case emissions are reported.

4.2.4 Deviation from Test Standard

No deviation.

4.2.5 Test Setup

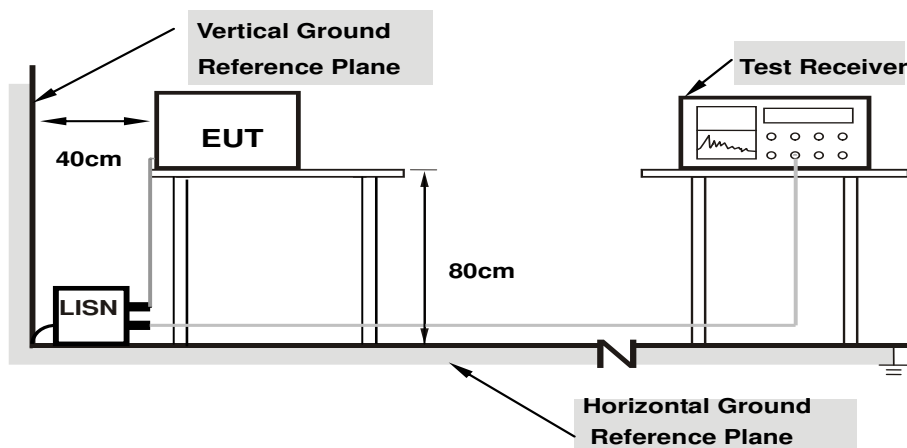

Note: 1.Support units were connected to second LISN.

For the actual test configuration, please refer to the attached file (Test Setup Photo).

4.2.6 EUT Operating Condition

Same as 4.1.6.

4.2.7 Test Results (Mode 1)

CDD Mode

Phase	Line (L)	Detector Function	Quasi-Peak (QP) / Average (AV)
-------	----------	-------------------	--------------------------------

Phase Of Power : Line (L)										
No	Frequency (MHz)	Correction Factor (dB)	Reading Value (dBuV)		Emission Level (dBuV)		Limit (dBuV)		Margin (dB)	
			Q.P.	AV.	Q.P.	AV.	Q.P.	AV.	Q.P.	AV.
1	0.15781	10.37	31.65	9.95	42.02	20.32	65.58	55.58	-23.55	-35.25
2	0.23594	10.35	23.02	7.70	33.37	18.05	62.24	52.24	-28.87	-34.19
3	3.39844	10.52	18.91	10.10	29.43	20.62	56.00	46.00	-26.57	-25.38
4	6.11328	10.69	20.30	12.72	30.99	23.41	60.00	50.00	-29.01	-26.59
5	12.54688	11.07	23.11	17.77	34.18	28.84	60.00	50.00	-25.82	-21.16
6	16.10938	11.28	23.60	18.97	34.88	30.25	60.00	50.00	-25.12	-19.75

Remarks:

1. Q.P. and AV. are abbreviations of quasi-peak and average individually.
2. The emission levels of other frequencies were very low against the limit.
3. Margin value = Emission level – Limit value
4. Correction factor = Insertion loss + Cable loss
5. Emission Level = Correction Factor + Reading Value

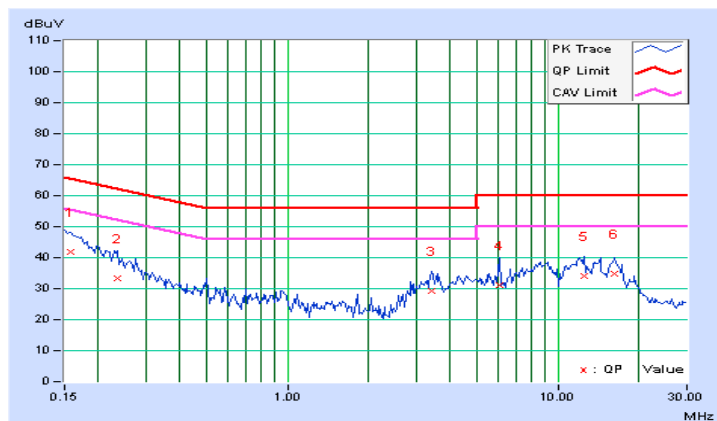

Phase	Neutral (N)	Detector Function	Quasi-Peak (QP) / Average (AV)
-------	-------------	-------------------	--------------------------------

Phase Of Power : Neutral (N)										
No	Frequency (MHz)	Correction Factor (dB)	Reading Value (dBuV)		Emission Level (dBuV)		Limit (dBuV)		Margin (dB)	
			Q.P.	AV.	Q.P.	AV.	Q.P.	AV.	Q.P.	AV.
1	0.15000	10.38	32.76	10.83	43.14	21.21	66.00	56.00	-22.86	-34.79
2	0.18125	10.39	31.52	23.20	41.91	33.59	64.43	54.43	-22.52	-20.84
3	2.86831	10.55	18.63	10.73	29.18	21.28	56.00	46.00	-26.82	-24.72
4	4.72656	10.71	20.44	14.03	31.15	24.74	56.00	46.00	-24.85	-21.26
5	11.99609	11.05	25.95	20.26	37.00	31.31	60.00	50.00	-23.00	-18.69
6	16.56250	11.31	23.16	18.34	34.47	29.65	60.00	50.00	-25.53	-20.35

Remarks:

1. Q.P. and AV. are abbreviations of quasi-peak and average individually.
2. The emission levels of other frequencies were very low against the limit.
3. Margin value = Emission level – Limit value
4. Correction factor = Insertion loss + Cable loss
5. Emission Level = Correction Factor + Reading Value

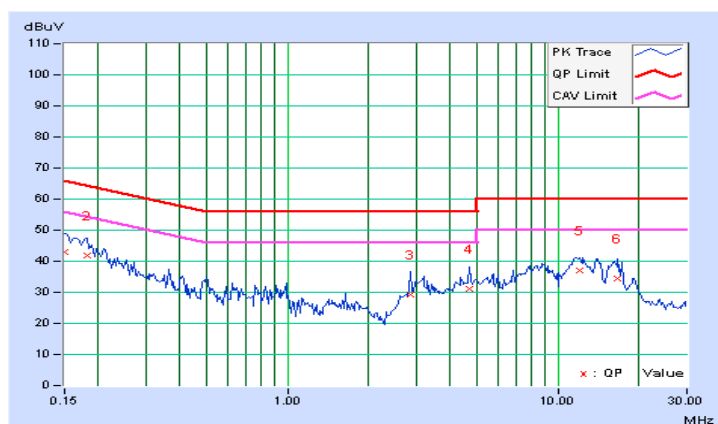

4.2.8 Test Results (Mode 2)

CDD Mode

Phase	Line (L)	Detector Function	Quasi-Peak (QP) / Average (AV)
-------	----------	-------------------	--------------------------------

Phase Of Power : Line (L)										
No	Frequency (MHz)	Correction Factor (dB)	Reading Value (dBuV)		Emission Level (dBuV)		Limit (dBuV)		Margin (dB)	
			Q.P.	AV.	Q.P.	AV.	Q.P.	AV.	Q.P.	AV.
1	0.15000	10.38	35.50	20.19	45.88	30.57	66.00	56.00	-20.12	-25.43
2	0.16953	10.36	33.87	18.87	44.23	29.23	64.98	54.98	-20.75	-25.75
3	0.19297	10.35	30.50	15.17	40.85	25.52	63.91	53.91	-23.06	-28.39
4	0.31406	10.36	18.35	4.11	28.71	14.47	59.86	49.86	-31.16	-35.40
5	0.94297	10.32	9.10	7.89	19.42	18.21	56.00	46.00	-36.58	-27.79
6	10.43359	10.93	15.44	10.40	26.37	21.33	60.00	50.00	-33.63	-28.67

Remarks:

1. Q.P. and AV. are abbreviations of quasi-peak and average individually.
2. The emission levels of other frequencies were very low against the limit.
3. Margin value = Emission level – Limit value
4. Correction factor = Insertion loss + Cable loss
5. Emission Level = Correction Factor + Reading Value

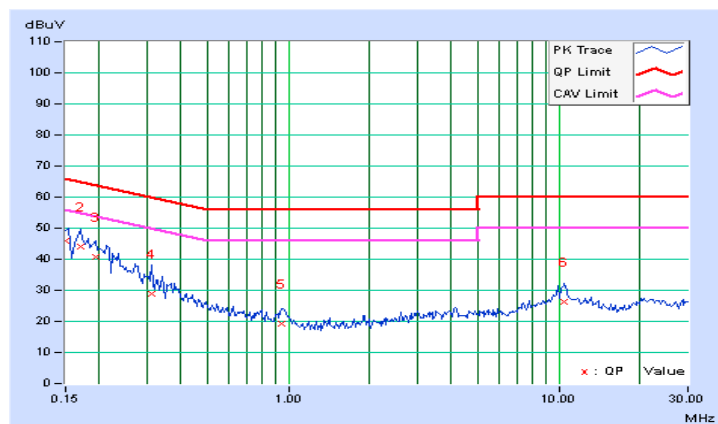

Phase	Neutral (N)	Detector Function	Quasi-Peak (QP) / Average (AV)
-------	-------------	-------------------	--------------------------------

Phase Of Power : Neutral (N)										
No	Frequency (MHz)	Correction Factor (dB)	Reading Value (dBuV)		Emission Level (dBuV)		Limit (dBuV)		Margin (dB)	
			Q.P.	AV.	Q.P.	AV.	Q.P.	AV.	Q.P.	AV.
1	0.16562	10.38	34.61	18.31	44.99	28.69	65.18	55.18	-20.18	-26.48
2	0.21641	10.39	28.02	12.71	38.41	23.10	62.96	52.96	-24.54	-29.85
3	0.26719	10.40	21.34	7.15	31.74	17.55	61.20	51.20	-29.46	-33.65
4	0.36875	10.42	15.13	2.29	25.55	12.71	58.53	48.53	-32.98	-35.82
5	3.25000	10.59	10.02	4.20	20.61	14.79	56.00	46.00	-35.39	-31.21
6	9.93359	10.92	13.63	9.22	24.55	20.14	60.00	50.00	-35.45	-29.86

Remarks:

1. Q.P. and AV. are abbreviations of quasi-peak and average individually.
2. The emission levels of other frequencies were very low against the limit.
3. Margin value = Emission level – Limit value
4. Correction factor = Insertion loss + Cable loss
5. Emission Level = Correction Factor + Reading Value

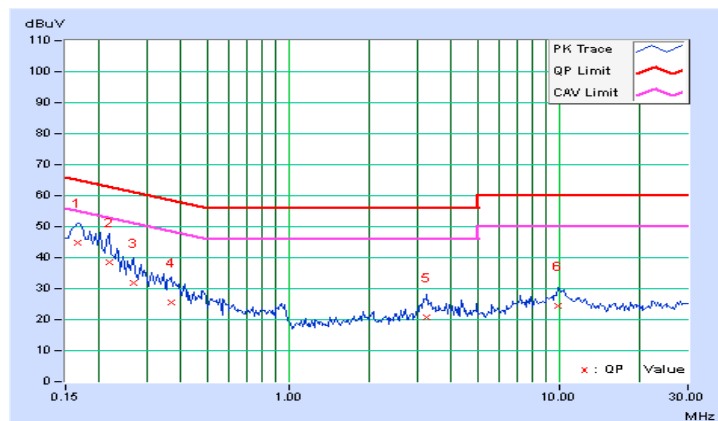

4.3 Transmit Power Measurement

4.3.1 Limits of Transmit Power Measurement

Operation Band	EUT Category		LIMIT
U-NII-1		Outdoor Access Point	1 Watt (30 dBm) (Max. e.i.r.p \leq 125mW(21 dBm) at any elevation angle above 30 degrees as measured from the horizon)
		Fixed point-to-point Access Point	1 Watt (30 dBm)
		Indoor Access Point	1 Watt (30 dBm)
		Mobile and Portable client device	250mW (24 dBm)
U-NII-2A		√	250mW (24 dBm) or 11 dBm+10 log B*
U-NII-2C		√	250mW (24 dBm) or 11 dBm+10 log B*
U-NII-3			1 Watt (30 dBm)

*B is the 26 dB emission bandwidth in megahertz

Per KDB 662911 Method of conducted output power measurement on IEEE 802.11 devices,

Array Gain = 0 dB (i.e., no array gain) for $N_{ANT} \leq 4$;

Array Gain = 0 dB (i.e., no array gain) for channel widths ≥ 40 MHz for any N_{ANT} ;

Array Gain = $5 \log(N_{ANT}/N_{SS})$ dB or 3 dB, whichever is less for 20-MHz channel widths with $N_{ANT} \geq 5$.

For power measurements on all other devices: Array Gain = $10 \log(N_{ANT}/N_{SS})$ dB.

4.3.2 Test Setup
FOR POWER OUTPUT MEASUREMENT

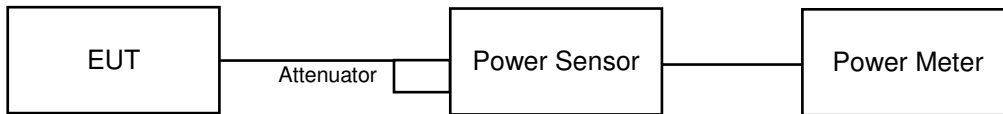

FOR 26dB OCCUPIED BANDWIDTH

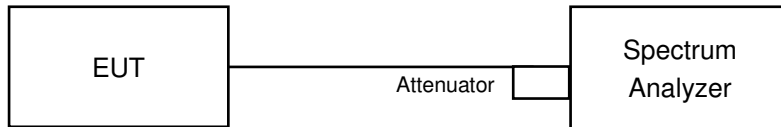

4.3.3 Test Instruments
FOR POWER OUTPUT MEASUREMENT

DESCRIPTION & MANUFACTURER	MODEL NO.	SERIAL NO.	CALIBRATED DATE	CALIBRATED UNTIL
Power meter Anritsu	ML2495A	1014008	Apr. 28, 2015	Apr. 27, 2016
Power sensor Anritsu	MA2411B	0917122	Apr. 28, 2015	Apr. 27, 2016

- NOTE:**
1. The test was performed in Oven room 2.
 2. The calibration interval of the above test instruments is 12 months and the calibrations are traceable to NML/ROC and NIST/USA.
 3. Tested Date: Dec. 29, 2015

FOR 26dB OCCUPIED BANDWIDTH

DESCRIPTION & MANUFACTURER	MODEL NO.	SERIAL NO.	CALIBRATED DATE	CALIBRATED UNTIL
SPECTRUM ANALYZER R&S	FSP40	100060	May 08, 2015	May 07, 2016

- NOTE:**
1. The test was performed in Oven room 2.
 2. The calibration interval of the above test instruments is 12 months and the calibrations are traceable to NML/ROC and NIST/USA.
 3. Tested Date: Dec. 29, 2015

4.3.4 Test Procedure

FOR AVERAGE POWER MEASUREMENT

Method PM is used to perform output power measurement, trigger and gating function of wide band power meter with average sensor is enabled to measure max output power of TX on burst. Duty factor is not added to measured value.

FOR 26dB OCCUPIED BANDWIDTH

1. Set RBW = approximately 1% of the emission bandwidth.
2. Set the VBW > RBW.
3. Detector = Peak.
4. Trace mode = max hold.
5. Measure the maximum width of the emission that is 26 dB down from the peak of the emission. Compare this with the RBW setting of the analyzer. Readjust RBW and repeat measurement as needed until the RBW/EBW ratio is approximately 1%.

4.3.5 Deviation from Test Standard

No deviation.

4.3.6 EUT Operating Condition

The software provided by client to enable the EUT under transmission condition continuously at lowest, middle and highest channel frequencies individually.

4.3.7 Test Result
CDD Mode
POWER OUTPUT:

Chan.	Chan. Freq. (MHz)	Maximum Conducted Power (dBm)				Total Power (mW)	Total Power (dBm)	Limit (dBm)	Pass / Fail
		Chain 0	Chain 1	Chain 2	Chain 3				
802.11a									
52	5260	18.22	18.21	17.46	17.56	245.331	23.90	24	PASS
60	5300	17.92	17.98	17.50	17.39	235.812	23.73	24	PASS
64	5320	18.11	18.27	17.66	17.63	248.145	23.95	24	PASS
100	5500	17.88	17.85	17.65	17.57	237.688	23.76	24	PASS
116	5580	17.95	17.65	18.24	17.32	241.215	23.82	24	PASS
140	5700	17.44	17.55	18.39	17.65	239.582	23.79	24	PASS
802.11ac (VHT20)									
52	5260	18.00	18.14	17.58	17.76	245.243	23.90	24	PASS
60	5300	18.10	17.92	17.64	17.81	244.98	23.89	24	PASS
64	5320	17.95	18.22	17.44	17.76	243.914	23.87	24	PASS
100	5500	17.81	17.96	17.65	17.54	237.876	23.76	24	PASS
116	5580	18.25	17.54	18.10	17.42	243.361	23.86	24	PASS
140	5700	17.56	18.07	17.72	17.30	233.996	23.69	24	PASS
802.11ac (VHT40)									
54	5270	18.20	18.16	17.43	17.71	245.888	23.91	24	PASS
62	5310	18.15	17.94	17.15	17.50	235.657	23.72	24	PASS
102	5510	17.91	17.86	17.74	17.77	242.166	23.84	24	PASS
110	5550	17.66	18.00	17.85	17.18	234.635	23.70	24	PASS
134	5670	17.91	17.76	18.53	17.54	249.545	23.97	24	PASS
802.11ac (VHT80)									
58	5290	18.04	18.08	17.34	17.44	237.612	23.76	24	PASS
106	5530	18.14	17.69	17.77	17.76	243.457	23.86	24	PASS
122	5610	18.15	17.54	17.75	17.65	239.843	23.80	24	PASS

26dB BANDWIDTH:

Channel	Channel Frequency (MHz)	26dBc Bandwidth (MHz)			
		Chain 0	Chain 1	Chain 2	Chain 3
802.11a					
52	5260	21.74	21.67	21.73	21.69
60	5300	21.65	21.68	21.67	21.76
64	5320	21.69	21.70	21.34	21.69
100	5500	21.57	21.55	21.55	21.52
116	5580	21.68	21.91	21.55	21.61
140	5700	21.66	21.74	21.55	21.58
802.11ac (VHT20)					
52	5260	21.88	21.77	21.83	21.74
60	5300	21.97	21.94	21.87	21.89
64	5320	21.88	21.82	21.75	21.74
100	5500	21.89	21.68	21.67	21.64
116	5580	22.13	21.42	21.50	21.70
140	5700	22.07	21.71	21.83	21.73
802.11ac (VHT40)					
54	5270	41.31	41.40	41.39	41.31
62	5310	41.13	41.35	41.42	41.39
102	5510	41.07	41.48	41.12	41.11
110	5550	41.76	41.30	41.24	41.42
134	5670	41.90	41.41	41.33	41.43
802.11ac (VHT80)					
58	5290	82.10	82.12	81.86	82.11
106	5530	81.82	81.79	81.57	81.75
122	5610	82.36	82.00	82.21	81.91

Note: For FCC output power limitation is determined based on 26dB bandwidth.

Power Limit = 11dBm + 10logB < UNII Band 2A~2C>			
Channel Number	Freq.(MHz)	Min. B (MHz)	Determined Conducted Limit (dBm)
802.11a			
52	5260	21.67	24.35 > 24
60	5300	21.65	24.35 > 24
64	5320	21.34	24.29 > 24
100	5500	21.52	24.32 > 24
116	5580	21.55	24.33 > 24
140	5700	21.55	24.33 > 24
802.11ac (VHT20)			
52	5260	21.74	24.37 > 24
60	5300	21.87	24.39 > 24
64	5320	21.74	24.37 > 24
100	5500	21.64	24.35 > 24
116	5580	21.42	24.3 > 24
140	5700	21.71	24.37 > 24
802.11ac (VHT40)			
54	5270	41.31	27.16 > 24
62	5310	41.13	27.14 > 24
102	5510	41.07	27.13 > 24
110	5550	41.24	27.15 > 24
134	5670	41.33	27.16 > 24
802.11ac (VHT80)			
58	5290	81.86	30.13 > 24
106	5530	81.57	30.11 > 24
122	5610	81.91	30.13 > 24

SPECTRUM PLOT OF WORST VALUE

802.11a – Chain (2): CH 64

802.11ac (VHT20) – Chain (1): CH 116

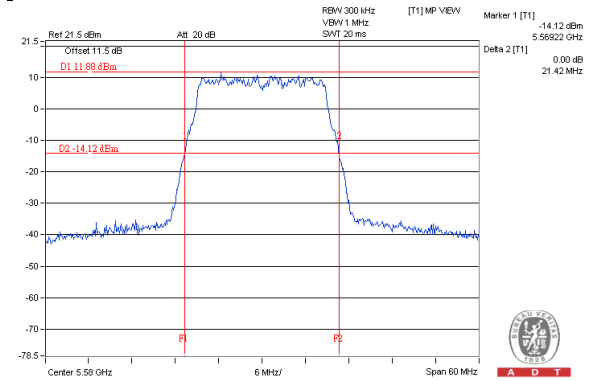
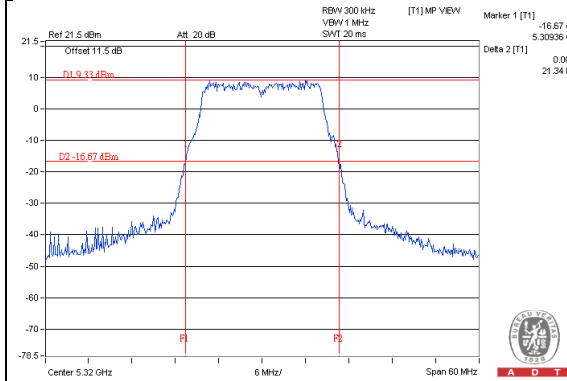

802.11ac (VHT40) – Chain (0): CH 102

802.11ac (VHT80) – Chain (2): CH 106

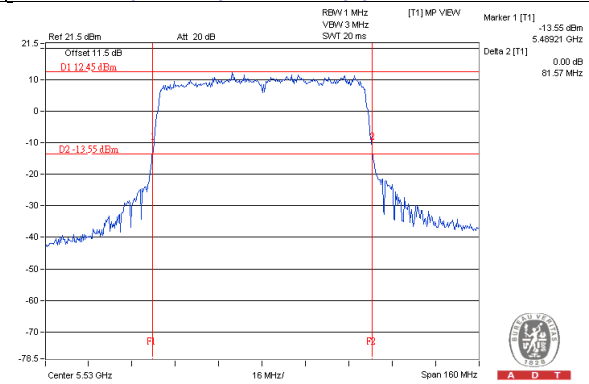
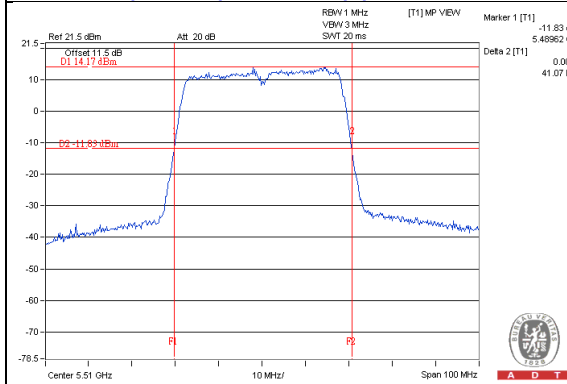

Beamforming Mode
POWER OUTPUT:

Chan.	Chan. Freq. (MHz)	Maximum Conducted Power (dBm)				Total Power (mW)	Total Power (dBm)	Limit (dBm)	Pass / Fail
		Chain 0	Chain 1	Chain 2	Chain 3				
802.11ac (VHT20)									
52	5260	18.00	18.14	17.58	17.76	245.243	23.90	24	PASS
60	5300	18.10	17.92	17.64	17.81	244.98	23.89	24	PASS
64	5320	17.95	18.22	17.44	17.76	243.914	23.87	24	PASS
100	5500	17.81	17.96	17.65	17.54	237.876	23.76	23.77	PASS
116	5580	18.04	17.38	17.96	17.24	233.865	23.69	23.77	PASS
140	5700	17.56	18.07	17.72	17.30	233.996	23.69	23.77	PASS
802.11ac (VHT40)									
54	5270	18.20	18.16	17.43	17.71	245.888	23.91	24	PASS
62	5310	18.15	17.94	17.15	17.50	235.657	23.72	24	PASS
102	5510	17.75	17.66	17.54	17.60	232.209	23.66	23.77	PASS
110	5550	17.66	18.00	17.85	17.18	234.635	23.70	23.77	PASS
134	5670	17.76	17.58	18.33	17.23	237.906	23.76	23.77	PASS
802.11ac (VHT80)									
58	5290	18.04	18.08	17.34	17.44	237.612	23.76	24	PASS
106	5530	17.95	17.56	17.42	17.58	231.877	23.65	23.77	PASS
122	5610	17.96	17.58	17.50	17.36	230.481	23.63	23.77	PASS

- Note: 1. For U-NII-2A band: Directional gain = $-1.38\text{dBi} + 10\log(4) = 4.64\text{dBi} < 6\text{dBi}$, so the power limit shall not be reduced.
2. For U-NII-2C band : Directional gain = $6.23\text{dBi} > 6\text{dBi}$, so the power limit shall be reduced to "Determined Conducted Limit-(6.23-6)"

26dB BANDWIDTH:

Channel	Channel Frequency (MHz)	26dBc Bandwidth (MHz)			
		Chain 0	Chain 1	Chain 2	Chain 3
802.11ac (VHT20)					
52	5260	21.88	21.77	21.83	21.74
60	5300	21.97	21.94	21.87	21.89
64	5320	21.88	21.82	21.75	21.74
100	5500	21.89	21.68	21.67	21.64
116	5580	22.13	21.42	21.50	21.70
140	5700	22.07	21.71	21.83	21.73
802.11ac (VHT40)					
54	5270	41.31	41.40	41.39	41.31
62	5310	41.13	41.35	41.42	41.39
102	5510	41.07	41.48	41.12	41.11
110	5550	41.76	41.30	41.24	41.42
134	5670	41.90	41.41	41.33	41.43
802.11ac (VHT80)					
58	5290	82.10	82.12	81.86	82.11
106	5530	81.82	81.79	81.57	81.75
122	5610	82.36	82.00	82.21	81.91

Note: For FCC output power limitation is determined based on 26dB bandwidth.

Power Limit = 11dBm + 10logB < UNII Band 2A~2C>			
Channel Number	Freq.(MHz)	Min. B (MHz)	Determined Conducted Limit (dBm)
802.11ac (VHT20)			
52	5260	21.74	24.37 > 24
60	5300	21.87	24.39 > 24
64	5320	21.74	24.37 > 24
100	5500	21.64	24.35 > 24
116	5580	21.42	24.3 > 24
140	5700	21.71	24.37 > 24
802.11ac (VHT40)			
54	5270	41.31	27.16 > 24
62	5310	41.13	27.14 > 24
102	5510	41.07	27.13 > 24
110	5550	41.24	27.15 > 24
134	5670	41.33	27.16 > 24
802.11ac (VHT80)			
58	5290	81.86	30.13 > 24
106	5530	81.57	30.11 > 24
122	5610	81.91	30.13 > 24

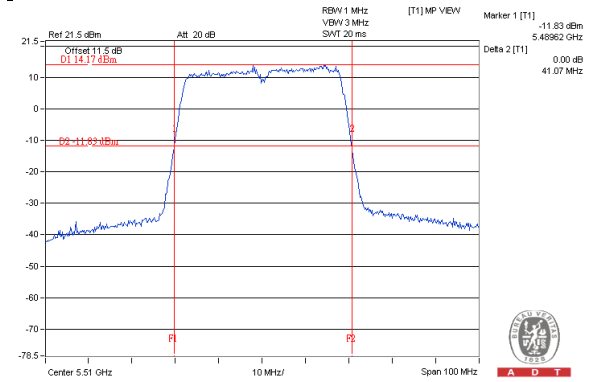
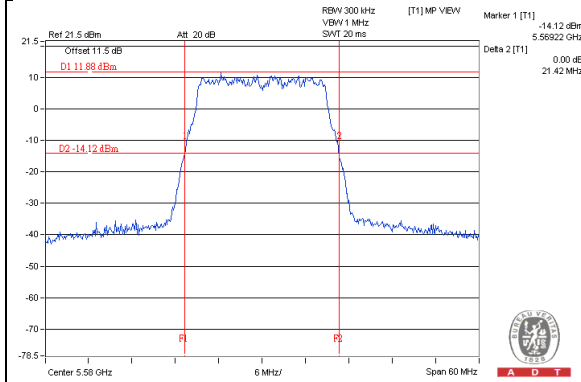
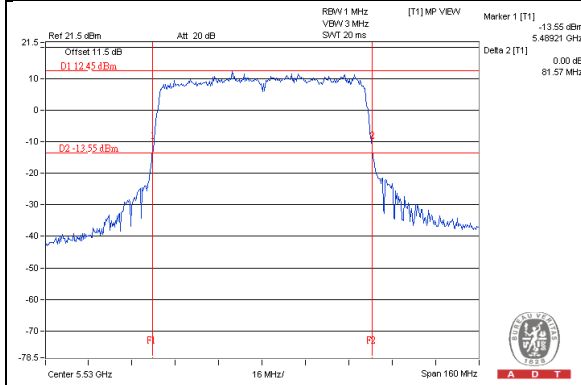
SPECTRUM PLOT OF WORST VALUE**802.11ac (VHT20) – Chain (1): CH 116****802.11ac (VHT40) – Chain (0): CH 102****802.11ac (VHT80) – Chain (2): CH 106**

4.4 Peak Power Spectral Density Measurement

4.4.1 Limits of Peak Power Spectral Density Measurement

Operation Band	EUT Category		LIMIT
U-NII-1		Outdoor Access Point	17dBm/ MHz
		Fixed point-to-point Access Point	
		Indoor Access Point	
		Mobile and Portable client device	11dBm/ MHz
U-NII-2A	√		11dBm/ MHz
U-NII-2C	√		11dBm/ MHz
U-NII-3			30dBm/ 500kHz

4.4.2 Test Setup

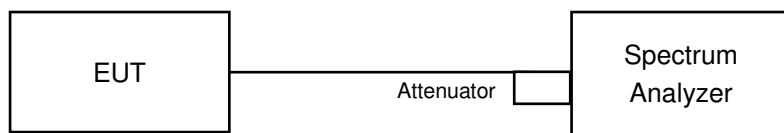

4.4.3 Test Instruments

DESCRIPTION & MANUFACTURER	MODEL NO.	SERIAL NO.	CALIBRATED DATE	CALIBRATED UNTIL
SPECTRUM ANALYZER R&S	FSP40	100060	May 08, 2015	May 07, 2016

- NOTE:**
1. The test was performed in Oven room 2.
 2. The calibration interval of the above test instruments is 12 months and the calibrations are traceable to NML/ROC and NIST/USA.
 3. Tested Date: Dec. 29, 2015

4.4.4 Test Procedure

For 802.11a, 802.11ac (VHT20) & 802.11ac (VHT40)

Using method SA-1

1. Set span to encompass the entire emission bandwidth (EBW) of the signal.
2. Set RBW = 1 MHz, Set VBW \geq 3 MHz, Detector = RMS
3. Sweep time = auto, trigger set to "free run".
4. Trace average at least 100 traces in power averaging mode.
5. Record the max value

For 802.11ac (VHT80)

Using method SA-2

1. Set span to encompass the entire emission bandwidth (EBW) of the signal.
2. Set RBW = 1 MHz, Set VBW \geq 3 MHz, Detector = RMS
3. Sweep time = auto, trigger set to "free run".
4. Trace average at least 100 traces in power averaging mode.
5. Record the max value and add 10 log (1/duty cycle)

4.4.5 Deviation from Test Standard

No deviation.

4.4.6 EUT Operating Condition

Same as Item 4.3.6.

4.4.7 Test Results

CDD Mode

Chan.	Chan. Freq. (MHz)	PSD (dBm/MHz)				Total Power Density (dBm/MHz)	MAX. Limit (dBm/MHz)	Pass / Fail
		Chain 0	Chain 1	Chain 2	Chain 3			
802.11a								
52	5260	5.02	5.08	4.28	4.27	10.70	11	Pass
60	5300	4.87	4.95	4.19	4.54	10.67	11	Pass
64	5320	5.20	5.23	4.29	4.55	10.86	11	Pass
100	5500	4.23	3.59	5.00	4.65	10.42	10.77	Pass
116	5580	5.98	4.29	4.92	3.28	10.75	10.77	Pass
140	5700	3.96	2.99	3.94	4.90	10.02	10.77	Pass
802.11ac (VHT20)								
52	5260	4.40	4.61	4.49	4.14	10.43	11	Pass
60	5300	4.69	4.90	4.38	4.19	10.57	11	Pass
64	5320	4.16	4.98	4.21	4.15	10.41	11	Pass
100	5500	4.19	4.24	4.52	4.32	10.34	10.77	Pass
116	5580	4.69	4.97	5.71	2.37	10.62	10.77	Pass
140	5700	3.18	4.39	2.86	2.73	9.36	10.77	Pass
802.11ac (VHT40)								
54	5270	1.38	1.40	1.37	1.36	7.40	11	Pass
62	5310	1.11	1.29	1.07	1.03	7.15	11	Pass
102	5510	1.18	1.16	1.12	1.20	7.19	10.77	Pass
110	5550	0.85	1.33	1.39	0.52	7.06	10.77	Pass
134	5670	1.17	0.76	1.37	0.77	7.05	10.77	Pass

- Note: 1. Method a) of power density measurement of KDB 662911 is using for calculating total power density. Total power density is summing entire spectra across corresponding frequency bins on the various outputs by computer.
2. For U-NII-2A band: Directional gain = $-1.38\text{dBi} + 10\log(4) = 4.64\text{dBi} < 6\text{dBi}$, so the power density limit shall not be reduced.
3. For U-NII-2C band: Directional gain = $6.23\text{dBi} > 6\text{dBi}$, so the power density limit shall be reduced to $11-(6.23-6) = 10.77\text{dBm}$.

Chan.	Chan. Freq. (MHz)	PSD w/o duty factor (dBm/MHz)				Duty Factor (dB)	Total PSD with Duty Factor (dBm/MHz)	MAX. Limit (dBm/MHz)	Pass / Fail
		Chain 0	Chain 1	Chain 2	Chain 3				
802.11ac (VHT80)									
58	5290	-1.68	-1.61	-2.13	-2.26	0.21	4.32	11	Pass
106	5530	-0.05	-0.04	-0.20	-0.12	0.21	6.13	10.77	Pass
122	5610	-0.18	-0.12	-0.20	-0.19	0.21	6.06	10.77	Pass

- Note: 1. Method a) of power density measurement of KDB 662911 is using for calculating total power density. Total power density is summing entire spectra across corresponding frequency bins on the various outputs by computer.
2. For U-NII-2A band: Directional gain = $-1.38\text{dBi} + 10\log(4) = 4.64\text{dBi} < 6\text{dBi}$, so the power density limit shall not be reduced.
3. For U-NII-2C band: Directional gain = $6.23\text{dBi} > 6\text{dBi}$, so the power density limit shall be reduced to $11 - (6.23 - 6) = 10.77\text{dBm}$.
4. Refer to section 3.3 for duty cycle spectrum plot.

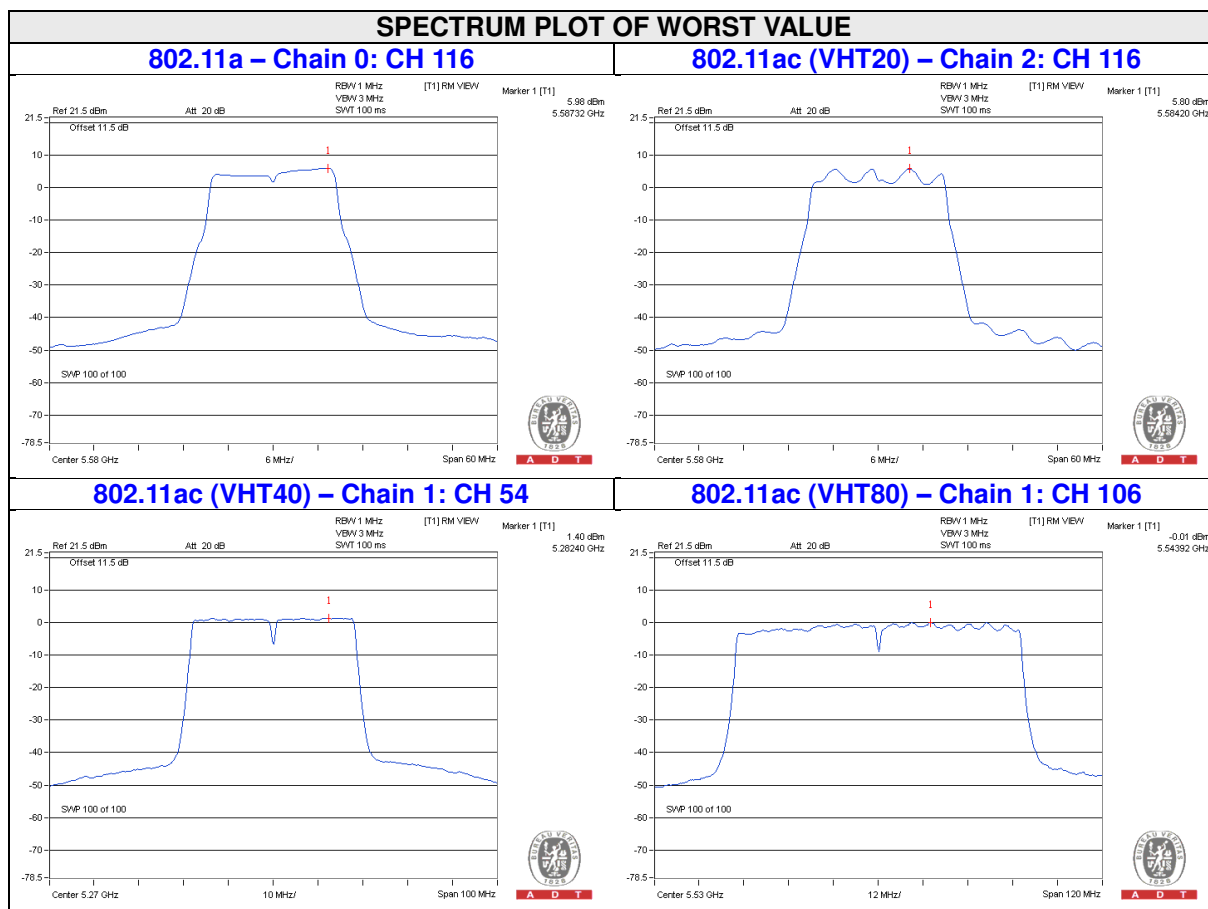

4.5 Frequency Stability Measurement

4.5.1 Limits of Frequency Stability Measurement

The frequency of the carrier signal shall be maintained within band of operation

4.5.2 Test Setup

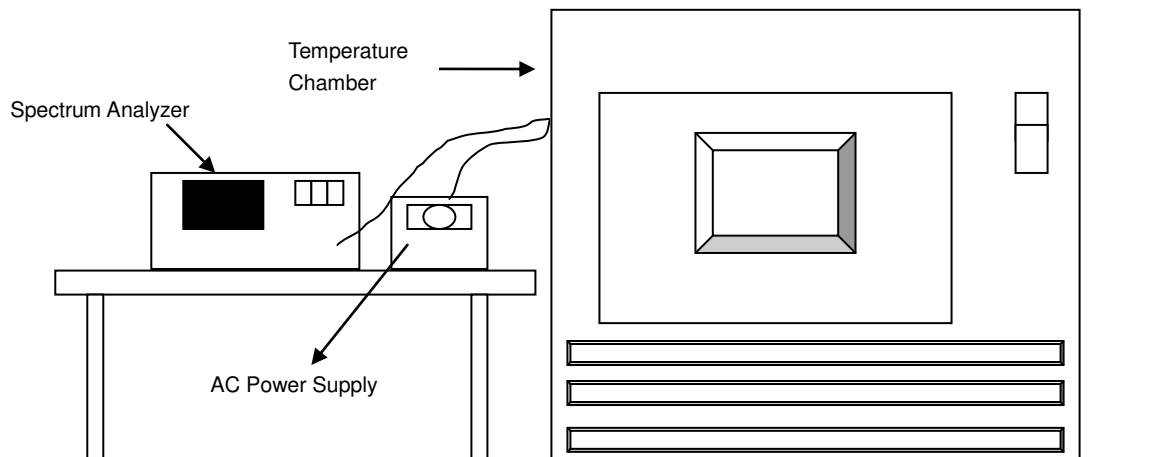

4.5.3 Test Instruments

DESCRIPTION & MANUFACTURER	MODEL NO.	SERIAL NO.	CALIBRATED DATE	CALIBRATED UNTIL
SPECTRUM ANALYZER R&S	FSP40	100060	May 08, 2015	May 07, 2016
AC Power Source Extech Electronics	6502	1140503	NA	NA
Temperature & Humidity Chamber GIANTFORCE	GTH-150-40-S P-AR	MAA0812-008	Jan. 12, 2015	Jan. 11, 2016
Digital Multimeter FLUKE	87III	73680266	Nov. 10, 2015	Nov. 09, 2016

- NOTE:**
1. The test was performed in Oven room 2.
 2. The calibration interval of the above test instruments is 12 months and the calibrations are traceable to NML/ROC and NIST/USA.
 3. Tested Date: Dec. 29, 2015

4.5.4 Test Procedure

- a. The EUT was placed inside the environmental test chamber and powered by nominal AC voltage.
- b. Turn the EUT on and couple its output to a spectrum analyzer.
- c. Turn the EUT off and set the chamber to the highest temperature specified.
- d. Allow sufficient time (approximately 30 min) for the temperature of the chamber to stabilize, turn the EUT on and measure the operating frequency after 2, 5, and 10 minutes.
- e. Repeat step 2 and 3 with the temperature chamber set to the lowest temperature.
- f. The test chamber was allowed to stabilize at +20 degree C for a minimum of 30 minutes. The supply voltage was then adjusted on the EUT from 85% to 115% and the frequency record.

4.5.5 Deviation from Test Standard

No deviation.

4.5.6 EUT Operating Condition

Set the EUT transmit at un-modulation mode to test frequency stability.

4.5.7 Test Results

FREQUENCY STABILITY VERSUS TEMP.									
OPERATING FREQUENCY: 5260MHz									
TEMP. (°C)	POWER SUPPLY (Vac)	0 MINUTE		2 MINUTE		5 MINUTE		10 MINUTE	
		Measured Frequency (MHz)	Frequency Drift (%)	Measured Frequency (MHz)	Frequency Drift (%)	Measured Frequency (MHz)	Frequency Drift (%)	Measured Frequency (MHz)	Frequency Drift (%)
50	120	5260.009	0.00017	5260.0095	0.00018	5260.0076	0.00014	5260.0078	0.00015
40	120	5259.9889	-0.00021	5259.9896	-0.00020	5259.9881	-0.00023	5259.9905	-0.00018
30	120	5260.0093	0.00018	5260.0081	0.00015	5260.0109	0.00021	5260.0114	0.00022
20	120	5260.0148	0.00028	5260.0149	0.00028	5260.0132	0.00025	5260.0139	0.00026
10	120	5260.0023	0.00004	5260.0022	0.00004	5260.0049	0.00009	5260.0036	0.00007
0	120	5259.9908	-0.00017	5259.994	-0.00011	5259.9924	-0.00014	5259.994	-0.00011
-10	120	5260.0148	0.00028	5260.0166	0.00032	5260.0126	0.00024	5260.0163	0.00031
-20	120	5260.0211	0.00040	5260.0166	0.00032	5260.0166	0.00032	5260.0172	0.00033
-30	120	5259.9776	-0.00043	5259.9791	-0.00040	5259.9768	-0.00044	5259.9751	-0.00047

FREQUENCY STABILITY VERSUS VOLTAGE									
OPERATING FREQUENCY: 5260MHz									
TEMP. (°C)	POWER SUPPLY (Vac)	0 MINUTE		2 MINUTE		5 MINUTE		10 MINUTE	
		Measured Frequency (MHz)	Frequency Drift (%)	Measured Frequency (MHz)	Frequency Drift (%)	Measured Frequency (MHz)	Frequency Drift (%)	Measured Frequency (MHz)	Frequency Drift (%)
20	138	5260.0155	0.00029	5260.0146	0.00028	5260.0139	0.00026	5260.0133	0.00025
	120	5260.0148	0.00028	5260.0149	0.00028	5260.0132	0.00025	5260.0139	0.00026
	102	5260.0147	0.00028	5260.0159	0.00030	5260.0124	0.00024	5260.0147	0.00028



5 Pictures of Test Arrangements

Please refer to the attached file (Test Setup Photo).



A D T

Appendix – Information on the Testing Laboratories

We, Bureau Veritas Consumer Products Services (H.K.) Ltd., Taoyuan Branch, were founded in 1988 to provide our best service in EMC, Radio, Telecom and Safety consultation. Our laboratories are accredited and approved according to ISO/IEC 17025.

If you have any comments, please feel free to contact us at the following:

Linko EMC/RF Lab

Tel: 886-2-26052180

Fax: 886-2-26051924

Hsin Chu EMC/RF Lab/Telecom Lab

Tel: 886-3-6668565

Fax: 886-3-6668323

Hwa Ya EMC/RF/Safety

Tel: 886-3-3183232

Fax: 886-3-3270892

Email: service.adt@tw.bureauveritas.com

Web Site: www.bureauveritas-adt.com

The address and road map of all our labs can be found in our web site also.

--- END ---