

## FCC Test Report

**Report No.:** RF150310E06-1

**FCC ID:** PY315100303

**Test Model:** C3700-100NAS

**Received Date:** Mar. 10, 2015

**Test Date:** Mar. 25 to Apr. 15, 2015

**Issued Date:** June 17, 2015

**Applicant:** NETGEAR, Inc.

**Address:** 350 East Plumeria Drive San Jose, CA 95134

**Issued By:** Bureau Veritas Consumer Products Services (H.K.) Ltd., Taoyuan Branch  
Hsin Chu Laboratory

**Lab Address:** No. 81-1, Lu Liao Keng, 9th Ling, Wu Lung Tsuen, Chiung Lin Hsiang, Hsin  
Chu Hsien 307, Taiwan R.O.C.

**Test Location (1):** No. 81-1, Lu Liao Keng, 9th Ling, Wu Lung Tsuen, Chiung Lin Hsiang, Hsin  
Chu Hsien 307, Taiwan R.O.C.

**Test Location (2):** No. 49, Ln. 206, Wende Rd., Shangshan Tsuen, Chiung Lin Hsiang, Hsin  
Chu Hsien 307, Taiwan R.O.C.



This report is for your exclusive use. Any copying or replication of this report to or for any other person or entity, or use of our name or trademark, is permitted only with our prior written permission. This report sets forth our findings solely with respect to the test samples identified herein. The results set forth in this report are not indicative or representative of the quality or characteristics of the lot from which a test sample was taken or any similar or identical product unless specifically and expressly noted. Our report includes all of the tests requested by you and the results thereof based upon the information that you provided to us. You have 60 days from date of issuance of this report to notify us of any material error or omission caused by our negligence, provided, however, that such notice shall be in writing and shall specifically address the issue you wish to raise. A failure to raise such issue within the prescribed time shall constitute your unqualified acceptance of the completeness of this report, the tests conducted and the correctness of the report contents. Unless specific mention, the uncertainty of measurement has been explicitly taken into account to declare the compliance or non-compliance to the specification. The report must not be used by the client to claim product certification, approval, or endorsement by TAF or any government agencies.

## Table of Contents

<b>Release Control Record</b> .....	<b>4</b>
<b>1 Certificate of Conformity</b> .....	<b>5</b>
<b>2 Summary of Test Results</b> .....	<b>6</b>
2.1 Measurement Uncertainty .....	6
2.2 Modification Record .....	6
<b>3 General Information</b> .....	<b>7</b>
3.1 General Description of EUT .....	7
3.2 Description of Test Modes .....	9
3.2.1 Test Mode Applicability and Tested Channel Detail .....	10
3.3 Duty Cycle of Test Signal .....	12
3.4 Description of Support Units .....	13
3.4.1 Configuration of System under Test .....	13
3.5 General Description of Applied Standard .....	14
<b>4 Test Types and Results</b> .....	<b>15</b>
4.1 Radiated Emission and Bandedge Measurement .....	15
4.1.1 Limits of Radiated Emission and Bandedge Measurement .....	15
4.1.2 Test Instruments .....	16
4.1.3 Test Procedure .....	17
4.1.4 Deviation from Test Standard .....	17
4.1.5 Test Setup .....	18
4.1.6 EUT Operating Condition .....	18
4.1.7 Test Results .....	19
4.2 Conducted Emission Measurement .....	46
4.2.1 Limits of Conducted Emission Measurement .....	46
4.2.2 Test Instruments .....	46
4.2.3 Test Procedure .....	47
4.2.4 Deviation from Test Standard .....	47
4.2.5 Test Setup .....	47
4.2.6 EUT Operating Condition .....	47
4.2.7 Test Results (Mode 1) .....	48
4.2.8 Test Results (Mode 2) .....	50
4.3 Transmit Power Measurement .....	52
4.3.1 Limits of Transmit Power Measurement .....	52
4.3.2 Test Setup .....	52
4.3.3 Test Instruments .....	52
4.3.4 Test Procedure .....	52
4.3.5 Deviation from Test Standard .....	52
4.3.6 EUT Operating Condition .....	53
4.3.7 Test Result .....	54
4.4 Peak Power Spectral Density Measurement .....	56
4.4.1 Limits of Peak Power Spectral Density Measurement .....	56
4.4.2 Test Setup .....	56
4.4.3 Test Instruments .....	56
4.4.4 Test Procedure .....	56
4.4.5 Deviation from Test Standard .....	57
4.4.6 EUT Operating Condition .....	57
4.4.7 Test Results .....	58
4.5 Frequency Stability Measurement .....	62
4.5.1 Limits of Frequency Stability Measurement .....	62
4.5.2 Test Setup .....	62
4.5.3 Test Instruments .....	62
4.5.4 Test Procedure .....	62
4.5.5 Deviation from Test Standard .....	62



4.5.6 EUT Operating Condition .....	62
4.5.7 Test Results .....	63
4.6 6dB Bandwidth Measurement .....	64
4.6.1 Limits of 6dB Bandwidth Measurement .....	64
4.6.2 Test Setup .....	64
4.6.3 Test Instruments .....	64
4.6.4 Test Procedure .....	64
4.6.5 Deviation from Test Standard .....	64
4.6.6 EUT Operating Condition .....	64
4.6.7 Test Results .....	65
<b>5 Pictures of Test Arrangements .....</b>	<b>67</b>
<b>Appendix – Information on the Testing Laboratories .....</b>	<b>68</b>



A D T

### Release Control Record

Issue No.	Description	Date Issued
RF150310E06-1	Original release.	June 17, 2015



A D T

## 1 Certificate of Conformity

**Product:** N600 WIFI Cable Modem Router

**Brand:** NETGEAR

**Test Model:** C3700-100NAS

**Sample Status:** ENGINEERING SAMPLE

**Applicant:** NETGEAR, Inc.

**Test Date:** Mar. 25 to Apr. 15, 2015

**Standard:** 47 CFR FCC Part 15, Subpart E (Section 15.407)  
ANSI C63.10:2009

The above equipment has been tested by **Bureau Veritas Consumer Products Services (H.K.) Ltd., Taoyuan Branch**, and found compliance with the requirement of the above standards. The test record, data evaluation & Equipment Under Test (EUT) configurations represented herein are true and accurate accounts of the measurements of the sample's EMC characteristics under the conditions specified in this report.

**Prepared by :** , **Date:** June 17, 2015  
Lori Chung / Specialist

**Approved by :** , **Date:** June 17, 2015  
May Chen / Manager

## 2 Summary of Test Results

47 CFR FCC Part 15, Subpart E (SECTION 15.407)			
FCC Clause	Test Item	Result	Remarks
15.407(b)(6)	AC Power Conducted Emissions	PASS	Meet the requirement of limit. Minimum passing margin is -6.6dB at 0.27109MHz.
15.407(b)(1/2/3/4/6)	Radiated Emissions & Band Edge Measurement	PASS	Meet the requirement of limit. Minimum passing margin is -0.1dB at 5150.00MHz, 5715.00MHz, 5725.00MHz & 5860.00MHz.
15.407(a)(1/2/3)	Max Average Transmit Power	PASS	Meet the requirement of limit.
15.407(a)(1/2/3)	Peak Power Spectral Density	PASS	Meet the requirement of limit.
15.407(e)	6dB bandwidth	PASS	Meet the requirement of limit. (U-NII-3 Band only)
15.407(g)	Frequency Stability	PASS	Meet the requirement of limit.
15.203	Antenna Requirement	PASS	Antenna connector is i-pex(MHF) not a standard connector.

**NOTE:** The EUT was operating in 2400 ~ 2483.5MHz, 5150~5250MHz and 5725~5850MHz frequencies band. This report was recorded the RF parameters including 5150~5250MHz and 5725~5850MHz. For the 2400 ~ 2483.5MHz RF parameters was recorded in another test report.

### 2.1 Measurement Uncertainty

Where relevant, the following measurement uncertainty levels have been estimated for tests performed on the EUT as specified in CISPR 16-4-2:

Measurement	Frequency	Expanded Uncertainty (k=2) (±)
Conducted Emissions at mains ports	150kHz ~ 30MHz	2.86 dB
Radiated Emissions up to 1 GHz	30MHz ~1GHz	5.43 dB
Radiated Emissions above 1 GHz	1GHz ~ 6GHz	3.72 dB
	6GHz ~ 18GHz	4.00 dB
	18GHz ~ 40GHz	4.11 dB

### 2.2 Modification Record

There were no modifications required for compliance.

### 3 General Information

#### 3.1 General Description of EUT

Product	N600 WIFI Cable Modem Router
Brand	NETGEAR
Test Model	C3700-100NAS
Status of EUT	ENGINEERING SAMPLE
Power Supply Rating	12Vdc from power adapter
Modulation Type	CCK, DQPSK, DBPSK for DSSS 64QAM, 16QAM, QPSK, BPSK for OFDM
Modulation Technology	DSSS, OFDM
Transfer Rate	802.11b: up to 11Mbps 802.11a / g: up to 54Mbps 802.11n: up to 300Mbps
Operating Frequency	<b>For 15.407</b> 5.18 ~ 5.24GHz, 5.745 ~ 5.825GHz
	<b>For 15.247</b> 2.412 ~ 2.462GHz
Number of Channel	<b>For 15.407</b> 9 for 802.11a, 802.11n (HT20) 4 for 802.11n (HT40)
	<b>For 15.247</b> 11 for 802.11b, 802.11g, 802.11n (HT20) 7 for 802.11n (HT40)
Output Power	<b>For 15.407</b> <b>1TX Mode:</b> 802.11a: 162.555mW 802.11n (HT20): 164.816mW 802.11n (HT40): 67.453mW <b>2TX Mode:</b> 802.11n (HT20): 332.024mW 802.11n (HT40): 117.634mW
	<b>For 15.247</b> <b>1TX Mode:</b> 802.11b: 194.536mW 802.11g: 297.852mW 802.11n (HT20): 311.172mW 802.11n (HT40): 217.27mW <b>2TX Mode:</b> 802.11n (HT20): 563.682mW 802.11n (HT40): 339.721mW
Antenna Type	Refer to Note
Antenna Connector	Refer to Note
Accessory Device	Adapter x 1
Data Cable Supplied	NA

Note:

- The emission of the simultaneous operation (2.4GHz & 5GHz) has been evaluated and no non-compliance was found.
- The antennas provided to the EUT, please refer to the following table:

Antenna No.	PCB Chain No.	Ant. Gain(dBi) <Including cable loss>	Frequency range (GHz to GHz)	Ant. Type	Connector Type
1	Left	0.3	2.4~2.4835	PIFA	i-pex(MHF)
2		2.6	5.15~5.85		
3	Right	2.3	2.4~2.4835	PIFA	i-pex(MHF)
4		1.8	5.15~5.85		

- The EUT must be supplied with a power adapter and following two different models could be chosen as following table:

No	P/N	Brand Name	Model No.	Spec.
1	332-10757-01	NETGEAR	ADS-40FPA-12 12030GPCU	Input: 100-240V, 1A, 50-60Hz Output: 12V, 2.5A DC output cable: 1.8m, unshielded
2	332-10758-01	NETGEAR	2ABL030F 1 NA	Input: 100-120V, 1A, 50-60Hz Output: 12V, 2.5A DC output cable: 1.8m, unshielded

For Radiated Emission test, the EUT was pre-tested with adapter 1 & 2, the worst case was found in adapter 2. Therefore only the test data of the adapter 2 was recorded in this report.

- The EUT incorporates a MIMO function.

2.4GHz Band			
MODULATION MODE	DATA RATE (MCS)	TX & RX CONFIGURATION	
802.11b	1 ~ 11Mbps	1TX (fix on chain 0)	2RX
802.11g	6 ~ 54Mbps	1TX (fix on chain 0)	2RX
802.11n (HT20)	MCS 0~7	1TX (fix on chain 0)	2RX
	MCS 8~15	2TX	2RX
802.11n (HT40)	MCS 0~7	1TX (fix on chain 0)	2RX
	MCS 8~15	2TX	2RX
5GHz Band			
MODULATION MODE	DATA RATE (MCS)	TX & RX CONFIGURATION	
802.11a	6 ~ 54Mbps	1TX (fix on chain 0)	2RX
802.11n (HT20)	MCS 0~7	1TX (fix on chain 0)	2RX
	MCS 8~15	2TX	2RX
802.11n (HT40)	MCS 0~7	1TX (fix on chain 0)	2RX
	MCS 8~15	2TX	2RX

Remark: “\*” means the device operate with two spatial stream (Nss = 2) with different data, and two signals are not correlated.

- The above EUT information is declared by manufacturer and for more detailed features description, please refer to the manufacturer's specifications or user's manual.



### 3.2 Description of Test Modes

#### For 5180 ~ 5240MHz

4 channels are provided for 802.11a, 802.11n (HT20):

Channel	Frequency	Channel	Frequency
36	5180 MHz	44	5220 MHz
40	5200 MHz	48	5240 MHz

2 channels are provided for 802.11n (HT40):

Channel	Frequency	Channel	Frequency
38	5190 MHz	46	5230 MHz

#### For 5745 ~ 5825MHz:

5 channels are provided for 802.11a, 802.11n (HT20):

Channel	Frequency	Channel	Frequency
149	5745MHz	161	5805MHz
153	5765MHz	165	5825MHz
157	5785MHz		

2 channels are provided for 802.11n (HT40):

Channel	Frequency	Channel	Frequency
151	5755MHz	159	5795MHz

### 3.2.1 Test Mode Applicability and Tested Channel Detail

EUT CONFIGURE MODE	APPLICABLE TO				DESCRIPTION
	RE≥1G	RE<1G	PLC	APCM	
1	√	√	√	√	With adapter 2
2	-	-	√	-	With adapter 1

Where **RE≥1G**: Radiated Emission above 1GHz

**RE<1G**: Radiated Emission below 1GHz

**PLC**: Power Line Conducted Emission

**APCM**: Antenna Port Conducted Measurement

**NOTE**: “-” means no effect.

#### **Radiated Emission Test (Above 1GHz):**

- Pre-Scan has been conducted to determine the worst-case mode from all possible combinations between available modulations, data rates and antenna ports (if EUT with antenna diversity architecture).
- Following channel(s) was (were) selected for the final test as listed below.

1TX MODE						
MODE	FREQ. BAND (MHz)	AVAILABLE CHANNEL	TESTED CHANNEL	MODULATION TECHNOLOGY	MODULATION TYPE	DATA RATE (Mbps)
802.11a	5180-5240	36 to 48	36, 40, 48	OFDM	BPSK	6
802.11n (HT20)		36 to 48	36, 40, 48	OFDM	BPSK	6.5
802.11n (HT40)		38 to 46	38, 46	OFDM	BPSK	13.5
802.11a	5745-5825	149 to 165	149, 157, 165	OFDM	BPSK	6
802.11n (HT20)		149 to 165	149, 157, 165	OFDM	BPSK	6.5
802.11n (HT40)		151 to 159	151, 159	OFDM	BPSK	13.5
2TX MODE						
MODE	FREQ. BAND (MHz)	AVAILABLE CHANNEL	TESTED CHANNEL	MODULATION TECHNOLOGY	MODULATION TYPE	DATA RATE (Mbps)
802.11n (HT20)	5180-5240	36 to 48	36, 40, 48	OFDM	BPSK	13
802.11n (HT40)		38 to 46	38, 46	OFDM	BPSK	27
802.11n (HT20)	5745-5825	149 to 165	149, 157, 165	OFDM	BPSK	13
802.11n (HT40)		151 to 159	151, 159	OFDM	BPSK	27

#### **Radiated Emission Test (Below 1GHz):**

- Pre-Scan has been conducted to determine the worst-case mode from all possible combinations between available modulations, data rates and antenna ports (if EUT with antenna diversity architecture).
- Following channel(s) was (were) selected for the final test as listed below.

2TX MODE						
MODE	FREQ. BAND (MHz)	AVAILABLE CHANNEL	TESTED CHANNEL	MODULATION TECHNOLOGY	MODULATION TYPE	DATA RATE (Mbps)
802.11n (HT20)	5180-5240	36 to 48	48	OFDM	BPSK	13

**Power Line Conducted Emission Test:**

- Pre-Scan has been conducted to determine the worst-case mode from all possible combinations between available modulations, data rates and antenna ports (if EUT with antenna diversity architecture).
- Following channel(s) was (were) selected for the final test as listed below.

2TX MODE						
MODE	FREQ. BAND (MHz)	AVAILABLE CHANNEL	TESTED CHANNEL	MODULATION TECHNOLOGY	MODULATION TYPE	DATA RATE (Mbps)
802.11n (HT20)	5180-5240	36 to 48	48	OFDM	BPSK	13

**Antenna Port Conducted Measurement:**

- This item includes all test value of each mode, but only includes spectrum plot of worst value of each mode.
- Pre-Scan has been conducted to determine the worst-case mode from all possible combinations between available modulations, data rates and antenna ports (if EUT with antenna diversity architecture).
- Following channel(s) was (were) selected for the final test as listed below.

1TX MODE						
MODE	FREQ. BAND (MHz)	AVAILABLE CHANNEL	TESTED CHANNEL	MODULATION TECHNOLOGY	MODULATION TYPE	DATA RATE (Mbps)
802.11a	5180-5240	36 to 48	36, 40, 48	OFDM	BPSK	6
802.11n (HT20)		36 to 48	36, 40, 48	OFDM	BPSK	6.5
802.11n (HT40)		38 to 46	38, 46	OFDM	BPSK	13.5
802.11a	5745-5825	149 to 165	149, 157, 165	OFDM	BPSK	6
802.11n (HT20)		149 to 165	149, 157, 165	OFDM	BPSK	6.5
802.11n (HT40)		151 to 159	151, 159	OFDM	BPSK	13.5
2TX MODE						
MODE	FREQ. BAND (MHz)	AVAILABLE CHANNEL	TESTED CHANNEL	MODULATION TECHNOLOGY	MODULATION TYPE	DATA RATE (Mbps)
802.11n (HT20)	5180-5240	36 to 48	36, 40, 48	OFDM	BPSK	13
802.11n (HT40)		38 to 46	38, 46	OFDM	BPSK	27
802.11n (HT20)	5745-5825	149 to 165	149, 157, 165	OFDM	BPSK	13
802.11n (HT40)		151 to 159	151, 159	OFDM	BPSK	27

**Test Condition:**

APPLICABLE TO	ENVIRONMENTAL CONDITIONS	INPUT POWER	TESTED BY
RE $\geq$ 1G	23deg. C, 68%RH	120Vac, 60Hz	Tim Ho
RE $<$ 1G	21deg. C, 65%RH	120Vac, 60Hz	Weiwei Lo
PLC	23deg. C, 65%RH	120Vac, 60Hz	Wythe Lin
APCM	25deg. C, 60%RH	120Vac, 60Hz	Anderson Chen

### 3.3 Duty Cycle of Test Signal

Duty cycle of test signal is  $\geq 98\%$ , duty factor is not required.

**802.11a:** Duty cycle =  $2.064 \text{ ms} / 2.084 \text{ ms} = 0.99$

**802.11n (HT20):** Duty cycle =  $1.906 \text{ ms} / 1.937 \text{ ms} = 0.984$

**802.11n (HT40):** Duty cycle =  $0.941 \text{ ms} / 0.958 \text{ ms} = 0.982$

**802.11a**

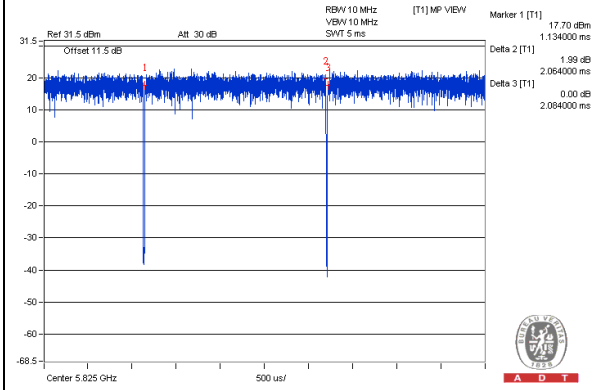

**802.11n (HT20)**

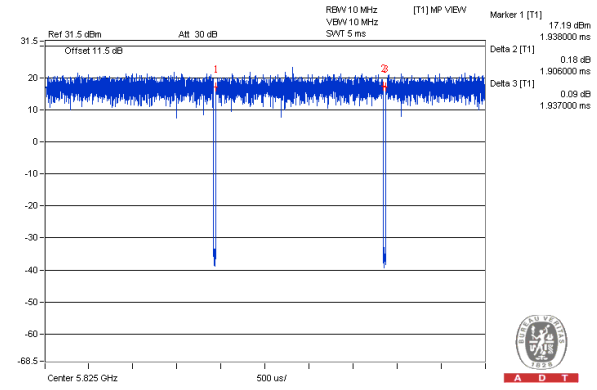

**802.11n (HT40)**

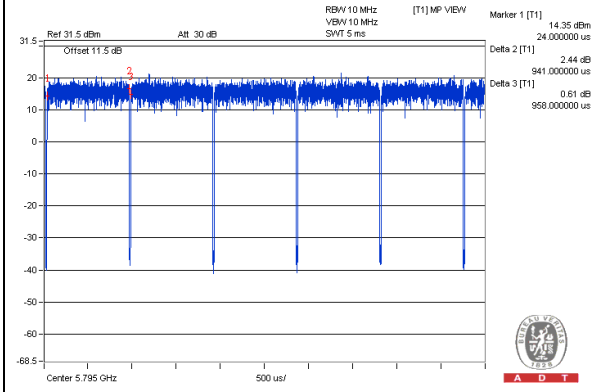

### 3.4 Description of Support Units

The EUT has been tested as an independent unit together with other necessary accessories or support units. The following support units or accessories were used to form a representative test configuration during the tests.

No.	Product	Brand	Model No.	Serial No.	FCC ID	Remark
A	iPod shuffle	Apple	MC749TA/A	CC4DMFJUDFDM	NA	Provided by Lab
B	NOTEBOOK COMPUTER	DELL	E6420	H62T3R1	FCC DoC	Provided by Lab
C	HUB	ZyXEL	ES-116P	S060H02000215	FCC DoC	Provided by Lab

**NOTE:**

1. All power cords of the above support units are non-shielded (1.8 m).

No.	Cable	Qty.	Length (m)	Shielded (Yes/ No)	Cores (Number)	Remark
1	DC	1	1.8	No	0	Supplied by Client
2	USB	1	0.1	Yes	0	Provided by Lab
3	Coaxial	1	10	Yes	0	Provided by Lab
4	UTP RJ45	1	10	No	0	Provided by Lab

#### 3.4.1 Configuration of System under Test

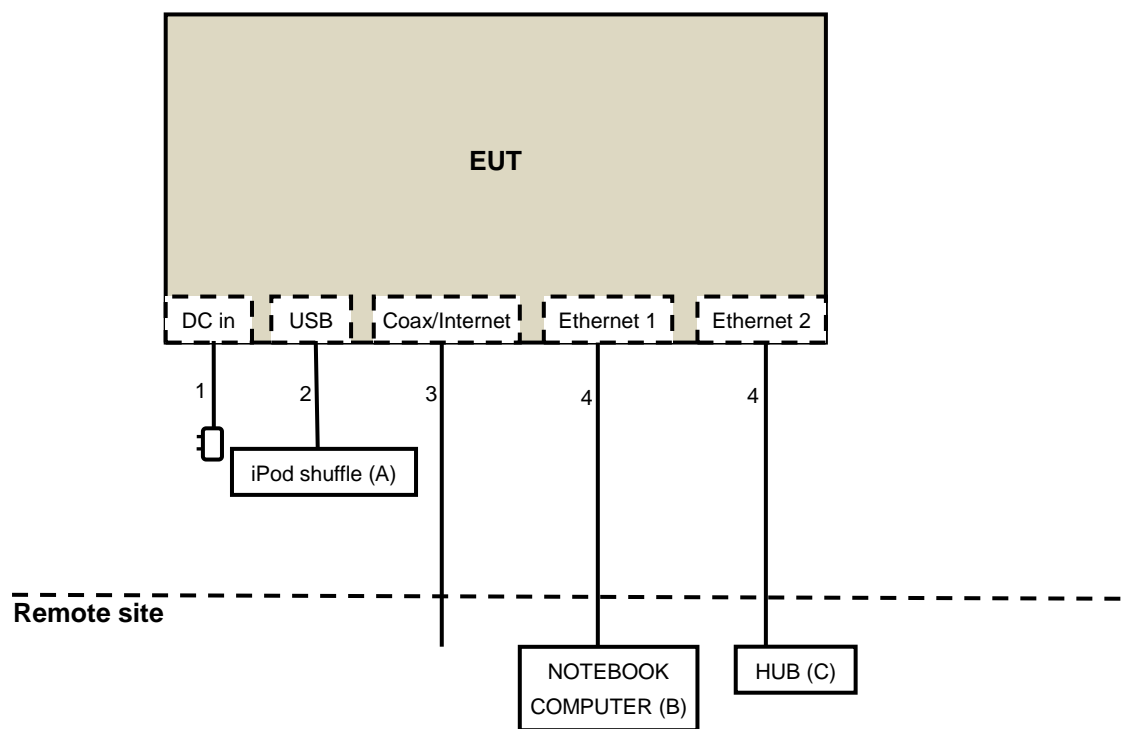



### 3.5 General Description of Applied Standard

The EUT is a RF Product. According to the specifications of the manufacturer, it must comply with the requirements of the following standards:

**FCC Part 15, Subpart E (15.407)**  
**789033 D02 General UNII Test Procedure New Rules v01**  
**662911 D01 Multiple Transmitter Output v02r01**  
ANSI C63.10-2009

All test items have been performed and recorded as per the above standards.

**NOTE:** The EUT has been verified to comply with the requirements of FCC Part 15, Subpart B, Class B (DoC). The test report has been issued separately.

## 4 Test Types and Results

### 4.1 Radiated Emission and Bandedge Measurement

#### 4.1.1 Limits of Radiated Emission and Bandedge Measurement

Radiated emissions which fall in the restricted bands must comply with the radiated emission limits specified as below table.

Frequencies (MHz)	Field Strength (microvolts/meter)	Measurement Distance (meters)
0.009 ~ 0.490	2400/F(kHz)	300
0.490 ~ 1.705	24000/F(kHz)	30
1.705 ~ 30.0	30	30
30 ~ 88	100	3
88 ~ 216	150	3
216 ~ 960	200	3
Above 960	500	3

#### NOTE:

1. The lower limit shall apply at the transition frequencies.
2. Emission level (dBuV/m) = 20 log Emission level (uV/m).
3. For frequencies above 1000MHz, the field strength limits are based on average detector, however, the peak field strength of any emission shall not exceed the maximum permitted average limits, specified above by more than 20dB under any condition of modulation.

#### LIMITS OF UNWANTED EMISSION OUT OF THE RESTRICTED BANDS

APPLICABLE TO	LIMIT	
789033 D02 General UNII Test Procedure New Rules v01	FIELD STRENGTH AT 3m	
	PK:74 (dBμV/m)	AV:54 (dBμV/m)
APPLICABLE TO	EIRP LIMIT	EQUIVALENT FIELD STRENGTH AT 3m
15.407(b)(1)	PK:-27 (dBm/MHz)	PK:68.2(dBμV/m)
15.407(b)(2)		
15.407(b)(3)		
15.407(b)(4)	PK:-27 (dBm/MHz) <sup>*1</sup> PK:-17 (dBm/MHz) <sup>*2</sup>	PK: 68.2(dBμV/m) <sup>*1</sup> PK:78.2 (dBμV/m) <sup>*2</sup>

**NOTE:** <sup>\*1</sup> beyond 10MHz of the band edge <sup>\*2</sup> within 10 MHz of band edge

The following formula is used to convert the equipment isotropic radiated power (eirp) to field strength:

$$E = \frac{1000000\sqrt{30P}}{3} \mu\text{V/m, where P is the eirp (Watts).}$$



## 4.1.2 Test Instruments

DESCRIPTION & MANUFACTURER	MODEL NO.	SERIAL NO.	CALIBRATED DATE	CALIBRATED UNTIL
MXE EMI Receiver Agilent	N9038A	MY50010156	Aug. 11, 2014	Aug. 10, 2015
Pre-Amplifier Mini-Circuits	ZFL-1000VH2 B	AMP-ZFL-04	Nov. 12, 2014	Nov. 11, 2015
Trilog Broadband Antenna SCHWARZBECK	VULB 9168	9168-361	Feb. 06, 2015	Feb. 05, 2016
RF Cable	NA	CHHCAB_001	Oct. 05, 2014	Oct. 04, 2015
Horn_Antenna AISI	AIH.8018	0000220091110	Aug. 26, 2014	Aug. 25, 2015
Pre-Amplifier Agilent	8449B	300801923	Oct. 28, 2014	Oct. 27, 2015
RF Cable	NA	131206 131213 131215 SNMY23685/4	Jan. 16, 2015	Jan. 15, 2016
Spectrum Analyzer R&S	FSV40	100964	July 05, 2014	July 04, 2015
Pre-Amplifier SPACEK LABS	SLKKa-48-6	9K16	Dec. 12, 2014	Dec. 11, 2015
Horn_Antenna SCHWARZBECK	BBHA 9170	9170-424	Aug. 26, 2014	Aug. 25, 2015
RF Cable	NA	329751/4 RF104-204	Dec. 11, 2014	Dec. 10, 2015
Software	ADT_Radiated _V8.7.07	NA	NA	NA
Antenna Tower & Turn Table CT	NA	NA	NA	NA
SPECTRUM ANALYZER R&S	FSP 40	100060	May 08, 2014	May 07, 2015
Power meter Anritsu	ML2495A	1014008	Apr. 30, 2014	Apr. 29, 2015
Power sensor Anritsu	MA2411B	0917122	Apr. 30, 2014	Apr. 29, 2015
Temperature & Humidity Chamber GIANTFORCE	GTH-150-40-S P-AR	MAA0812-008	Jan. 12, 2015	Jan. 11, 2016

**Note:**

1. The calibration interval of the above test instruments is 12 months and the calibrations are traceable to NML/ROC and NIST/USA.
2. The horn antenna, preamplifier (model: 8449B) are used only for the measurement of emission frequency above 1GHz if tested.
3. The test was performed in 966 Chamber No. H.
4. The FCC Site Registration No. is 797305.
5. The CANADA Site Registration No. is IC 7450H-3.
6. Tested Date: Apr. 10 to 13, 2015



#### 4.1.3 Test Procedure

- a. The EUT was placed on the top of a rotating table 0.8 meters above the ground at 3 meter chamber room for test. The table was rotated 360 degrees to determine the position of the highest radiation.
- b. The EUT was set 3 meters away from the interference-receiving antenna, which was mounted on the top of a variable-height antenna tower.
- c. The height of antenna is varied from one meter to four meters above the ground to determine the maximum value of the field strength. Both horizontal and vertical polarizations of the antenna are set to make the measurement.
- d. For each suspected emission, the EUT was arranged to its worst case and then the antenna was tuned to heights from 1 meter to 4 meters and the rotatable table was turned from 0 degrees to 360 degrees to find the maximum reading.
- e. The test-receiver system was set to quasi-peak detect function and specified bandwidth with maximum hold mode when the test frequency is below 1 GHz.
- f. The test-receiver system was set to peak and average detect function and specified bandwidth with maximum hold mode when the test frequency is above 1 GHz. If the peak reading value also meets average limit, measurement with the average detector is unnecessary.

#### Note:

1. For emission measurements above 1 GHz, the EUT shall be placed at a height of 1.5 m above the ground at 3 meter chamber room for test
2. The resolution bandwidth and video bandwidth of test receiver/spectrum analyzer is 120kHz for Quasi-peak detection (QP) at frequency below 1GHz.
3. The resolution bandwidth of test receiver/spectrum analyzer is 1 MHz and the video bandwidth is 3 MHz for Peak detection (PK) at frequency above 1GHz.
4. The resolution bandwidth of test receiver/spectrum analyzer is 1MHz and the video bandwidth is 3MHz for RMS Average (Duty cycle < 98%) for Average detection (AV) at frequency above 1GHz, then the measurement results was added to a correction factor ( $10 \log(1/\text{duty cycle})$ ).
5. The resolution bandwidth of test receiver/spectrum analyzer is 1MHz and the video bandwidth is 10Hz (Duty cycle  $\geq 98\%$ ) for Average detection (AV) at frequency above 1GHz.
6. All modes of operation were investigated and the worst-case emissions are reported.

#### 4.1.4 Deviation from Test Standard

No deviation.

#### 4.1.5 Test Setup

##### <Frequency Range below 1GHz>

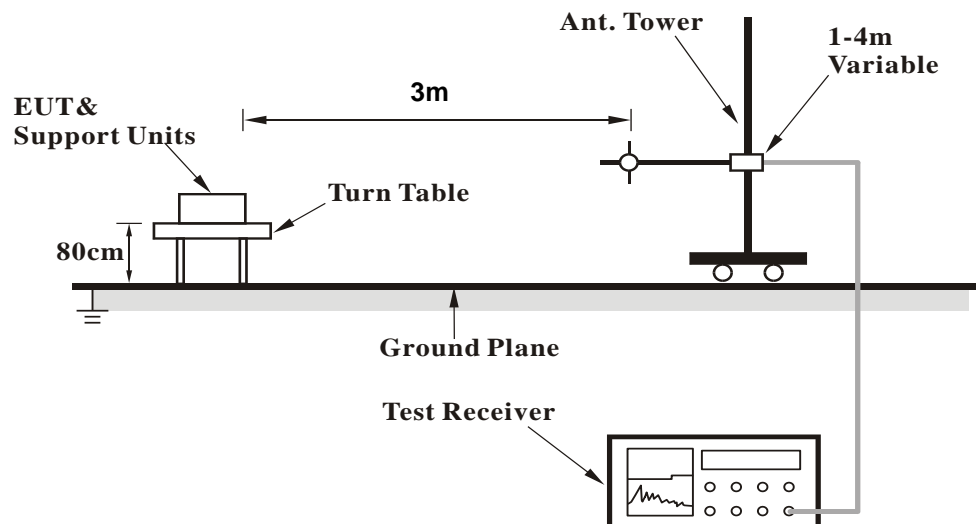

##### <Frequency Range above 1GHz>

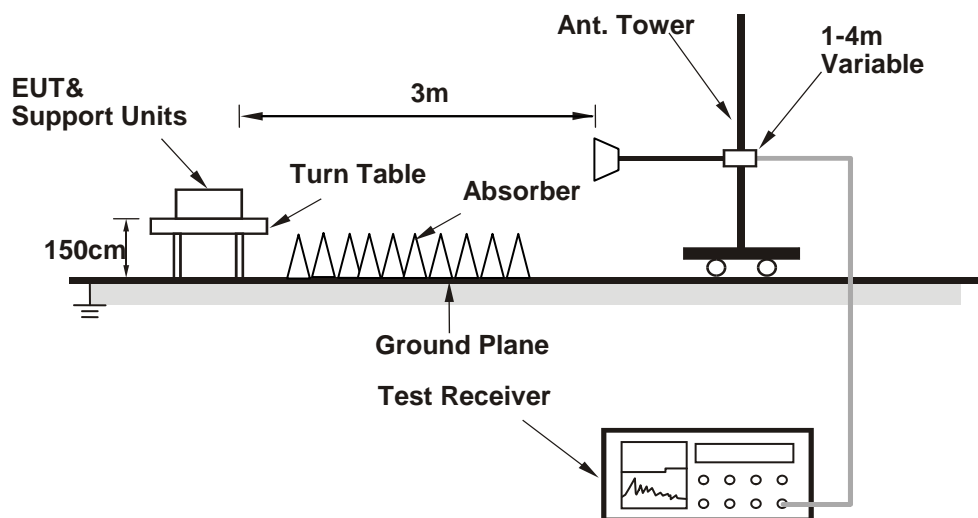

For the actual test configuration, please refer to the attached file (Test Setup Photo).

#### 4.1.6 EUT Operating Condition

1. Connect the EUT with the support unit B (NOTEBOOK COMPUTER) which is placed on remote site.
2. Controlling software (MTool.exe[2.0.1.0]) has been activated to set the EUT on specific status.

#### 4.1.7 Test Results

#### 1TX Mode

#### Above 1GHz Data

#### 802.11a

<b>CHANNEL</b>	TX Channel 36	<b>DETECTOR FUNCTION</b>	Peak (PK)
<b>FREQUENCY RANGE</b>	1GHz ~ 40GHz		Average (AV)

#### ANTENNA POLARITY & TEST DISTANCE: HORIZONTAL AT 3 M

NO.	FREQ. (MHz)	EMISSION LEVEL (dBuV/m)	LIMIT (dBuV/m)	MARGIN (dB)	ANTENNA HEIGHT (m)	TABLE ANGLE (Degree)	RAW VALUE (dBuV)	CORRECTION FACTOR (dB/m)
1	5150.00	62.1 PK	74.0	-11.9	1.11 H	81	58.26	3.84
2	5150.00	47.5 AV	54.0	-6.5	1.11 H	81	43.66	3.84
3	*5180.00	102.1 PK			1.11 H	81	98.18	3.92
4	*5180.00	92.4 AV			1.11 H	81	88.48	3.92
5	#10360.00	59.9 PK	74.0	-14.1	1.18 H	145	50.47	9.43
6	#10360.00	46.2 AV	54.0	-7.8	1.18 H	145	36.77	9.43
7	15540.00	52.8 PK	74.0	-21.2	1.20 H	132	38.77	14.03
8	15540.00	41.0 AV	54.0	-13.0	1.20 H	132	26.97	14.03

#### ANTENNA POLARITY & TEST DISTANCE: VERTICAL AT 3 M

NO.	FREQ. (MHz)	EMISSION LEVEL (dBuV/m)	LIMIT (dBuV/m)	MARGIN (dB)	ANTENNA HEIGHT (m)	TABLE ANGLE (Degree)	RAW VALUE (dBuV)	CORRECTION FACTOR (dB/m)
1	5150.00	73.5 PK	74.0	-0.5	1.39 V	129	69.66	3.84
2	5150.00	53.9 AV	54.0	-0.1	1.39 V	129	50.06	3.84
3	*5180.00	112.6 PK			1.39 V	127	108.68	3.92
4	*5180.00	102.9 AV			1.39 V	127	98.98	3.92
5	#10360.00	54.7 PK	74.0	-19.3	1.39 V	244	45.27	9.43
6	#10360.00	43.5 AV	54.0	-10.5	1.39 V	244	34.07	9.43
7	15540.00	52.7 PK	74.0	-21.3	1.00 V	138	38.67	14.03
8	15540.00	40.1 AV	54.0	-13.9	1.00 V	138	26.07	14.03

#### REMARKS:

1. Emission Level(dBuV/m) = Raw Value(dBuV) + Correction Factor(dB/m)
2. Correction Factor(dB/m) = Antenna Factor(dB/m) + Cable Factor(dB) – Pre-Amplifier Factor(dB)
3. The other emission levels were very low against the limit.
4. Margin value = Emission Level – Limit value
5. " \* ": Fundamental frequency.
6. " # ": The radiated frequency is out of the restricted band.

<b>CHANNEL</b>	TX Channel 40	<b>DETECTOR FUNCTION</b>	Peak (PK)
<b>FREQUENCY RANGE</b>	1GHz ~ 40GHz		Average (AV)

**ANTENNA POLARITY & TEST DISTANCE: HORIZONTAL AT 3 M**

NO.	FREQ. (MHz)	EMISSION LEVEL (dBuV/m)	LIMIT (dBuV/m)	MARGIN (dB)	ANTENNA HEIGHT (m)	TABLE ANGLE (Degree)	RAW VALUE (dBuV)	CORRECTION FACTOR (dB/m)
1	5150.00	62.1 PK	74.0	-11.9	1.15 H	74	58.26	3.84
2	5150.00	47.7 AV	54.0	-6.3	1.15 H	74	43.86	3.84
3	*5200.00	107.3 PK			1.15 H	74	103.34	3.96
4	*5200.00	97.3 AV			1.15 H	74	93.34	3.96
5	#10400.00	59.1 PK	74.0	-14.9	1.19 H	137	49.65	9.45
6	#10400.00	46.9 AV	54.0	-7.1	1.19 H	137	37.45	9.45
7	15600.00	53.3 PK	74.0	-20.7	1.20 H	137	39.12	14.18
8	15600.00	41.0 AV	54.0	-13.0	1.20 H	137	26.82	14.18

**ANTENNA POLARITY & TEST DISTANCE: VERTICAL AT 3 M**

NO.	FREQ. (MHz)	EMISSION LEVEL (dBuV/m)	LIMIT (dBuV/m)	MARGIN (dB)	ANTENNA HEIGHT (m)	TABLE ANGLE (Degree)	RAW VALUE (dBuV)	CORRECTION FACTOR (dB/m)
1	5150.00	73.7 PK	74.0	-0.3	1.11 V	126	69.86	3.84
2	5150.00	53.7 AV	54.0	-0.3	1.11 V	126	49.86	3.84
3	*5200.00	117.2 PK			1.02 V	137	113.24	3.96
4	*5200.00	107.5 AV			1.02 V	137	103.54	3.96
5	#10400.00	55.5 PK	74.0	-18.5	1.38 V	250	46.05	9.45
6	#10400.00	44.0 AV	54.0	-10.0	1.38 V	250	34.55	9.45
7	15600.00	52.5 PK	74.0	-21.5	1.00 V	156	38.32	14.18
8	15600.00	39.6 AV	54.0	-14.4	1.00 V	156	25.42	14.18

**REMARKS:**

1. Emission Level(dBuV/m) = Raw Value(dBuV) + Correction Factor(dB/m)
2. Correction Factor(dB/m) = Antenna Factor(dB/m) + Cable Factor(dB) – Pre-Amplifier Factor(dB)
3. The other emission levels were very low against the limit.
4. Margin value = Emission Level – Limit value
5. " \* ": Fundamental frequency.
6. " # ": The radiated frequency is out of the restricted band.

<b>CHANNEL</b>	TX Channel 48	<b>DETECTOR FUNCTION</b>	Peak (PK)
<b>FREQUENCY RANGE</b>	1GHz ~ 40GHz		Average (AV)

**ANTENNA POLARITY & TEST DISTANCE: HORIZONTAL AT 3 M**

NO.	FREQ. (MHz)	EMISSION LEVEL (dBuV/m)	LIMIT (dBuV/m)	MARGIN (dB)	ANTENNA HEIGHT (m)	TABLE ANGLE (Degree)	RAW VALUE (dBuV)	CORRECTION FACTOR (dB/m)
1	5150.00	62.6 PK	74.0	-11.4	1.12 H	81	58.76	3.84
2	5150.00	47.9 AV	54.0	-6.1	1.12 H	81	44.06	3.84
3	*5240.00	108.3 PK			1.12 H	81	104.35	3.95
4	*5240.00	98.6 AV			1.12 H	81	94.65	3.95
5	5350.00	56.7 PK	74.0	-17.3	1.12 H	81	52.63	4.07
6	5350.00	37.1 AV	54.0	-16.9	1.12 H	81	33.03	4.07
7	#10480.00	59.2 PK	74.0	-14.8	1.21 H	132	49.53	9.67
8	#10480.00	46.7 AV	54.0	-7.3	1.21 H	132	37.03	9.67
9	15720.00	52.9 PK	74.0	-21.1	1.24 H	127	39.01	13.89
10	15720.00	40.8 AV	54.0	-13.2	1.24 H	127	26.91	13.89

**ANTENNA POLARITY & TEST DISTANCE: VERTICAL AT 3 M**

NO.	FREQ. (MHz)	EMISSION LEVEL (dBuV/m)	LIMIT (dBuV/m)	MARGIN (dB)	ANTENNA HEIGHT (m)	TABLE ANGLE (Degree)	RAW VALUE (dBuV)	CORRECTION FACTOR (dB/m)
1	5150.00	66.4 PK	74.0	-7.6	1.11 V	113	62.56	3.84
2	5150.00	50.1 AV	54.0	-3.9	1.11 V	113	46.26	3.84
3	*5240.00	119.5 PK			1.11 V	113	115.55	3.95
4	*5240.00	109.8 AV			1.11 V	113	105.85	3.95
5	5350.00	57.2 PK	74.0	-16.8	1.11 V	113	53.13	4.07
6	5350.00	37.6 AV	54.0	-16.4	1.11 V	113	33.53	4.07
7	#10480.00	55.1 PK	74.0	-18.9	1.38 V	248	45.43	9.67
8	#10480.00	43.7 AV	54.0	-10.3	1.38 V	248	34.03	9.67
9	15720.00	52.4 PK	74.0	-21.6	1.00 V	152	38.51	13.89
10	15720.00	39.7 AV	54.0	-14.3	1.00 V	152	25.81	13.89

**REMARKS:**

1. Emission Level(dBuV/m) = Raw Value(dBuV) + Correction Factor(dB/m)
2. Correction Factor(dB/m) = Antenna Factor(dB/m) + Cable Factor(dB) – Pre-Amplifier Factor(dB)
3. The other emission levels were very low against the limit.
4. Margin value = Emission Level – Limit value
5. " \* ": Fundamental frequency.
6. " # ": The radiated frequency is out of the restricted band.

<b>CHANNEL</b>	TX Channel 149	<b>DETECTOR FUNCTION</b>	Peak (PK)
<b>FREQUENCY RANGE</b>	1GHz ~ 40GHz		Average (AV)

**ANTENNA POLARITY & TEST DISTANCE: HORIZONTAL AT 3 M**

NO.	FREQ. (MHz)	EMISSION LEVEL (dBuV/m)	LIMIT (dBuV/m)	MARGIN (dB)	ANTENNA HEIGHT (m)	TABLE ANGLE (Degree)	RAW VALUE (dBuV)	CORRECTION FACTOR (dB/m)
1	#5715.00	61.7 PK	74.0	-12.3	1.07 H	80	57.22	4.48
2	#5715.00	42.1 AV	54.0	-11.9	1.07 H	80	37.62	4.48
3	#5725.00	68.4 PK	78.2	-9.8	1.07 H	80	63.90	4.50
4	*5745.00	102.4 PK			1.07 H	80	97.91	4.49
5	*5745.00	91.7 AV			1.07 H	80	87.21	4.49
6	11490.00	59.2 PK	74.0	-14.8	1.21 H	119	49.16	10.04
7	11490.00	46.9 AV	54.0	-7.1	1.21 H	119	36.86	10.04
8	#17235.00	52.0 PK	74.0	-22.0	1.23 H	125	33.44	18.56
9	#17235.00	40.6 AV	54.0	-13.4	1.23 H	125	22.04	18.56

**ANTENNA POLARITY & TEST DISTANCE: VERTICAL AT 3 M**

NO.	FREQ. (MHz)	EMISSION LEVEL (dBuV/m)	LIMIT (dBuV/m)	MARGIN (dB)	ANTENNA HEIGHT (m)	TABLE ANGLE (Degree)	RAW VALUE (dBuV)	CORRECTION FACTOR (dB/m)
1	#5715.00	67.4 PK	74.0	-6.6	1.20 V	80	62.92	4.48
2	#5715.00	47.9 AV	54.0	-6.1	1.20 V	80	43.42	4.48
3	#5725.00	77.9 PK	78.2	-0.3	1.20 V	80	73.40	4.50
4	*5745.00	111.1 PK			1.00 V	115	106.61	4.49
5	*5745.00	100.9 AV			1.00 V	115	96.41	4.49
6	11490.00	54.4 PK	74.0	-19.6	1.27 V	254	44.36	10.04
7	11490.00	43.9 AV	54.0	-10.1	1.27 V	254	33.86	10.04
8	#17235.00	51.0 PK	74.0	-23.0	1.00 V	147	32.44	18.56
9	#17235.00	41.8 AV	54.0	-12.2	1.00 V	147	23.24	18.56

**REMARKS:**

1. Emission Level(dBuV/m) = Raw Value(dBuV) + Correction Factor(dB/m)
2. Correction Factor(dB/m) = Antenna Factor(dB/m) + Cable Factor(dB) – Pre-Amplifier Factor(dB)
3. The other emission levels were very low against the limit.
4. Margin value = Emission Level – Limit value
5. " \* ": Fundamental frequency.
6. " # ": The radiated frequency is out of the restricted band.

<b>CHANNEL</b>	TX Channel 157	<b>DETECTOR FUNCTION</b>	Peak (PK)
<b>FREQUENCY RANGE</b>	1GHz ~ 40GHz		Average (AV)

**ANTENNA POLARITY & TEST DISTANCE: HORIZONTAL AT 3 M**

NO.	FREQ. (MHz)	EMISSION LEVEL (dBuV/m)	LIMIT (dBuV/m)	MARGIN (dB)	ANTENNA HEIGHT (m)	TABLE ANGLE (Degree)	RAW VALUE (dBuV)	CORRECTION FACTOR (dB/m)
1	#5715.00	58.2 PK	74.0	-15.8	1.03 H	83	53.72	4.48
2	#5715.00	42.1 AV	54.0	-11.9	1.03 H	83	37.62	4.48
3	#5725.00	64.2 PK	78.2	-14.0	1.04 H	72	59.70	4.50
4	*5785.00	105.6 PK			1.06 H	90	101.10	4.50
5	*5785.00	96.2 AV			1.06 H	90	91.70	4.50
6	11570.00	58.0 PK	74.0	-16.0	1.23 H	95	47.92	10.08
7	11570.00	45.6 AV	54.0	-8.4	1.23 H	95	35.52	10.08
8	#17355.00	52.0 PK	74.0	-22.0	1.30 H	143	33.10	18.90
9	#17355.00	40.5 AV	54.0	-13.5	1.30 H	143	21.60	18.90

**ANTENNA POLARITY & TEST DISTANCE: VERTICAL AT 3 M**

NO.	FREQ. (MHz)	EMISSION LEVEL (dBuV/m)	LIMIT (dBuV/m)	MARGIN (dB)	ANTENNA HEIGHT (m)	TABLE ANGLE (Degree)	RAW VALUE (dBuV)	CORRECTION FACTOR (dB/m)
1	#5715.00	73.9 PK	74.0	-0.1	1.20 V	77	69.42	4.48
2	#5715.00	51.4 AV	54.0	-2.6	1.20 V	77	46.92	4.48
3	#5725.00	75.8 PK	78.2	-2.4	1.22 V	77	71.30	4.50
4	*5785.00	114.9 PK			1.02 V	129	110.40	4.50
5	*5785.00	105.0 AV			1.02 V	129	100.50	4.50
6	#5850.00	61.6 PK	78.2	-16.6	1.22 V	77	57.03	4.57
7	#5860.00	59.1 PK	74.0	-14.9	1.20 V	77	54.51	4.59
8	#5860.00	43.1 AV	54.0	-10.9	1.20 V	77	38.51	4.59
9	11570.00	54.3 PK	74.0	-19.7	1.30 V	259	44.22	10.08
10	11570.00	43.8 AV	54.0	-10.2	1.30 V	259	33.72	10.08
11	#17355.00	51.1 PK	74.0	-22.9	1.05 V	151	32.20	18.90
12	#17355.00	41.8 AV	54.0	-12.2	1.05 V	151	22.90	18.90

**REMARKS:**

1. Emission Level(dBuV/m) = Raw Value(dBuV) + Correction Factor(dB/m)
2. Correction Factor(dB/m) = Antenna Factor(dB/m) + Cable Factor(dB) – Pre-Amplifier Factor(dB)
3. The other emission levels were very low against the limit.
4. Margin value = Emission Level – Limit value
5. " \* ": Fundamental frequency.
6. " # ": The radiated frequency is out of the restricted band.

<b>CHANNEL</b>	TX Channel 165	<b>DETECTOR FUNCTION</b>	Peak (PK)
<b>FREQUENCY RANGE</b>	1GHz ~ 40GHz		Average (AV)

**ANTENNA POLARITY & TEST DISTANCE: HORIZONTAL AT 3 M**

NO.	FREQ. (MHz)	EMISSION LEVEL (dBuV/m)	LIMIT (dBuV/m)	MARGIN (dB)	ANTENNA HEIGHT (m)	TABLE ANGLE (Degree)	RAW VALUE (dBuV)	CORRECTION FACTOR (dB/m)
1	*5825.00	101.9 PK			1.05 H	94	97.37	4.53
2	*5825.00	91.3 AV			1.05 H	94	86.77	4.53
3	#5850.00	68.9 PK	78.2	-9.3	1.08 H	90	64.33	4.57
4	#5860.00	61.7 PK	74.0	-12.3	1.07 H	85	57.11	4.59
5	#5860.00	42.2 AV	54.0	-11.8	1.07 H	85	37.61	4.59
6	11650.00	59.2 PK	74.0	-14.8	1.24 H	98	49.23	9.97
7	11650.00	46.6 AV	54.0	-7.4	1.24 H	98	36.63	9.97
8	#17475.00	53.0 PK	74.0	-21.0	1.34 H	137	33.89	19.11
9	#17475.00	41.0 AV	54.0	-13.0	1.34 H	137	21.89	19.11

**ANTENNA POLARITY & TEST DISTANCE: VERTICAL AT 3 M**

NO.	FREQ. (MHz)	EMISSION LEVEL (dBuV/m)	LIMIT (dBuV/m)	MARGIN (dB)	ANTENNA HEIGHT (m)	TABLE ANGLE (Degree)	RAW VALUE (dBuV)	CORRECTION FACTOR (dB/m)
1	*5825.00	111.6 PK			1.00 V	91	107.07	4.53
2	*5825.00	102.6 AV			1.00 V	91	98.07	4.53
3	#5850.00	78.0 PK	78.2	-0.2	1.00 V	90	73.43	4.57
4	#5860.00	70.6 PK	74.0	-3.4	1.00 V	90	66.01	4.59
5	#5860.00	53.4 AV	54.0	-0.6	1.00 V	90	48.81	4.59
6	11650.00	54.3 PK	74.0	-19.7	1.33 V	256	44.33	9.97
7	11650.00	43.6 AV	54.0	-10.4	1.33 V	256	33.63	9.97
8	#17475.00	50.7 PK	74.0	-23.3	1.03 V	162	31.59	19.11
9	#17475.00	41.6 AV	54.0	-12.4	1.03 V	162	22.49	19.11

**REMARKS:**

1. Emission Level(dBuV/m) = Raw Value(dBuV) + Correction Factor(dB/m)
2. Correction Factor(dB/m) = Antenna Factor(dB/m) + Cable Factor(dB) – Pre-Amplifier Factor(dB)
3. The other emission levels were very low against the limit.
4. Margin value = Emission Level – Limit value
5. " \* ": Fundamental frequency.
6. " # ": The radiated frequency is out of the restricted band.



**802.11n (HT20)**

<b>CHANNEL</b>	TX Channel 36	<b>DETECTOR FUNCTION</b>	Peak (PK)
<b>FREQUENCY RANGE</b>	1GHz ~ 40GHz		Average (AV)

<b>ANTENNA POLARITY &amp; TEST DISTANCE: HORIZONTAL AT 3 M</b>								
NO.	FREQ. (MHz)	EMISSION LEVEL (dBuV/m)	LIMIT (dBuV/m)	MARGIN (dB)	ANTENNA HEIGHT (m)	TABLE ANGLE (Degree)	RAW VALUE (dBuV)	CORRECTION FACTOR (dB/m)
1	5150.00	61.7 PK	74.0	-12.3	1.13 H	96	57.86	3.84
2	5150.00	47.3 AV	54.0	-6.7	1.13 H	96	43.46	3.84
3	*5180.00	102.0 PK			1.13 H	96	98.08	3.92
4	*5180.00	92.2 AV			1.13 H	96	88.28	3.92
5	#10360.00	59.2 PK	74.0	-14.8	1.19 H	116	49.77	9.43
6	#10360.00	46.4 AV	54.0	-7.6	1.19 H	116	36.97	9.43
7	15540.00	53.4 PK	74.0	-20.6	1.26 H	119	39.37	14.03
8	15540.00	41.0 AV	54.0	-13.0	1.26 H	119	26.97	14.03

<b>ANTENNA POLARITY &amp; TEST DISTANCE: VERTICAL AT 3 M</b>								
NO.	FREQ. (MHz)	EMISSION LEVEL (dBuV/m)	LIMIT (dBuV/m)	MARGIN (dB)	ANTENNA HEIGHT (m)	TABLE ANGLE (Degree)	RAW VALUE (dBuV)	CORRECTION FACTOR (dB/m)
<b>1</b>	<b>5150.00</b>	<b>73.9 PK</b>	<b>74.0</b>	<b>-0.1</b>	<b>1.00 V</b>	<b>137</b>	<b>70.06</b>	<b>3.84</b>
2	5150.00	53.6 AV	54.0	-0.4	1.00 V	137	49.76	3.84
3	*5180.00	112.6 PK			1.00 V	137	108.68	3.92
4	*5180.00	102.8 AV			1.00 V	137	98.88	3.92
5	#10360.00	54.7 PK	74.0	-19.3	1.37 V	248	45.27	9.43
6	#10360.00	44.1 AV	54.0	-9.9	1.37 V	248	34.67	9.43
7	15540.00	52.8 PK	74.0	-21.2	1.00 V	167	38.77	14.03
8	15540.00	40.1 AV	54.0	-13.9	1.00 V	167	26.07	14.03

**REMARKS:**

- Emission Level(dBuV/m) = Raw Value(dBuV) + Correction Factor(dB/m)
- Correction Factor(dB/m) = Antenna Factor(dB/m) + Cable Factor(dB) – Pre-Amplifier Factor(dB)
- The other emission levels were very low against the limit.
- Margin value = Emission Level – Limit value
- " \* ": Fundamental frequency.
- " # ": The radiated frequency is out of the restricted band.

<b>CHANNEL</b>	TX Channel 40	<b>DETECTOR FUNCTION</b>	Peak (PK)
<b>FREQUENCY RANGE</b>	1GHz ~ 40GHz		Average (AV)

**ANTENNA POLARITY & TEST DISTANCE: HORIZONTAL AT 3 M**

NO.	FREQ. (MHz)	EMISSION LEVEL (dBuV/m)	LIMIT (dBuV/m)	MARGIN (dB)	ANTENNA HEIGHT (m)	TABLE ANGLE (Degree)	RAW VALUE (dBuV)	CORRECTION FACTOR (dB/m)
1	5150.00	61.9 PK	74.0	-12.1	1.11 H	89	58.06	3.84
2	5150.00	47.6 AV	54.0	-6.4	1.11 H	89	43.76	3.84
3	*5200.00	107.0 PK			1.11 H	87	103.04	3.96
4	*5200.00	97.2 AV			1.11 H	87	93.24	3.96
5	#10400.00	58.9 PK	74.0	-15.1	1.25 H	143	49.45	9.45
6	#10400.00	46.3 AV	54.0	-7.7	1.25 H	143	36.85	9.45
7	15600.00	52.7 PK	74.0	-21.3	1.21 H	136	38.52	14.18
8	15600.00	40.8 AV	54.0	-13.2	1.21 H	136	26.62	14.18

**ANTENNA POLARITY & TEST DISTANCE: VERTICAL AT 3 M**

NO.	FREQ. (MHz)	EMISSION LEVEL (dBuV/m)	LIMIT (dBuV/m)	MARGIN (dB)	ANTENNA HEIGHT (m)	TABLE ANGLE (Degree)	RAW VALUE (dBuV)	CORRECTION FACTOR (dB/m)
1	5150.00	73.3 PK	74.0	-0.7	1.00 V	135	69.46	3.84
2	5150.00	53.3 AV	54.0	-0.7	1.00 V	135	49.46	3.84
3	*5200.00	117.9 PK			1.00 V	136	113.94	3.96
4	*5200.00	108.0 AV			1.00 V	136	104.04	3.96
5	#10400.00	54.8 PK	74.0	-19.2	1.38 V	263	45.35	9.45
6	#10400.00	43.2 AV	54.0	-10.8	1.38 V	263	33.75	9.45
7	15600.00	52.9 PK	74.0	-21.1	1.00 V	163	38.72	14.18
8	15600.00	40.2 AV	54.0	-13.8	1.00 V	163	26.02	14.18

**REMARKS:**

1. Emission Level(dBuV/m) = Raw Value(dBuV) + Correction Factor(dB/m)
2. Correction Factor(dB/m) = Antenna Factor(dB/m) + Cable Factor(dB) – Pre-Amplifier Factor(dB)
3. The other emission levels were very low against the limit.
4. Margin value = Emission Level – Limit value
5. " \* ": Fundamental frequency.
6. " # ": The radiated frequency is out of the restricted band.

<b>CHANNEL</b>	TX Channel 48	<b>DETECTOR FUNCTION</b>	Peak (PK)
<b>FREQUENCY RANGE</b>	1GHz ~ 40GHz		Average (AV)

**ANTENNA POLARITY & TEST DISTANCE: HORIZONTAL AT 3 M**

NO.	FREQ. (MHz)	EMISSION LEVEL (dBuV/m)	LIMIT (dBuV/m)	MARGIN (dB)	ANTENNA HEIGHT (m)	TABLE ANGLE (Degree)	RAW VALUE (dBuV)	CORRECTION FACTOR (dB/m)
1	5150.00	63.1 PK	74.0	-10.9	1.16 H	83	59.26	3.84
2	5150.00	48.3 AV	54.0	-5.7	1.16 H	83	44.46	3.84
3	*5240.00	107.3 PK			1.16 H	83	103.35	3.95
4	*5240.00	98.9 AV			1.16 H	83	94.95	3.95
5	5350.00	56.3 PK	74.0	-17.7	1.16 H	83	52.23	4.07
6	5350.00	36.8 AV	54.0	-17.2	1.16 H	83	32.73	4.07
7	#10480.00	59.3 PK	74.0	-14.7	1.21 H	143	49.63	9.67
8	#10480.00	46.0 AV	54.0	-8.0	1.21 H	143	36.33	9.67
9	15720.00	52.3 PK	74.0	-21.7	1.22 H	136	38.41	13.89
10	15720.00	40.4 AV	54.0	-13.6	1.22 H	136	26.51	13.89

**ANTENNA POLARITY & TEST DISTANCE: VERTICAL AT 3 M**

NO.	FREQ. (MHz)	EMISSION LEVEL (dBuV/m)	LIMIT (dBuV/m)	MARGIN (dB)	ANTENNA HEIGHT (m)	TABLE ANGLE (Degree)	RAW VALUE (dBuV)	CORRECTION FACTOR (dB/m)
1	5150.00	66.1 PK	74.0	-7.9	1.00 V	135	62.26	3.84
2	5150.00	49.8 AV	54.0	-4.2	1.00 V	135	45.96	3.84
3	*5240.00	120.9 PK			1.00 V	135	116.95	3.95
4	*5240.00	110.1 AV			1.00 V	135	106.15	3.95
5	5350.00	62.1 PK	74.0	-11.9	1.00 V	135	58.03	4.07
6	5350.00	46.6 AV	54.0	-7.4	1.00 V	135	42.53	4.07
7	#10480.00	54.3 PK	74.0	-19.7	1.42 V	233	44.63	9.67
8	#10480.00	43.4 AV	54.0	-10.6	1.42 V	233	33.73	9.67
9	15720.00	53.5 PK	74.0	-20.5	1.00 V	138	39.61	13.89
10	15720.00	40.5 AV	54.0	-13.5	1.00 V	138	26.61	13.89

**REMARKS:**

- Emission Level(dBuV/m) = Raw Value(dBuV) + Correction Factor(dB/m)
- Correction Factor(dB/m) = Antenna Factor(dB/m) + Cable Factor(dB) – Pre-Amplifier Factor(dB)
- The other emission levels were very low against the limit.
- Margin value = Emission Level – Limit value
- " \* ": Fundamental frequency.
- " # ": The radiated frequency is out of the restricted band.

<b>CHANNEL</b>	TX Channel 149	<b>DETECTOR FUNCTION</b>	Peak (PK)
<b>FREQUENCY RANGE</b>	1GHz ~ 40GHz		Average (AV)

**ANTENNA POLARITY & TEST DISTANCE: HORIZONTAL AT 3 M**

NO.	FREQ. (MHz)	EMISSION LEVEL (dBuV/m)	LIMIT (dBuV/m)	MARGIN (dB)	ANTENNA HEIGHT (m)	TABLE ANGLE (Degree)	RAW VALUE (dBuV)	CORRECTION FACTOR (dB/m)
1	#5715.00	62.1 PK	74.0	-11.9	1.09 H	88	57.62	4.48
2	#5715.00	42.2 AV	54.0	-11.8	1.09 H	88	37.72	4.48
3	#5725.00	68.2 PK	78.2	-10.0	1.08 H	67	63.70	4.50
4	*5745.00	102.8 PK			1.02 H	69	98.31	4.49
5	*5745.00	92.0 AV			1.02 H	69	87.51	4.49
6	11490.00	58.6 PK	74.0	-15.4	1.14 H	128	48.56	10.04
7	11490.00	46.1 AV	54.0	-7.9	1.14 H	128	36.06	10.04
8	#17235.00	52.3 PK	74.0	-21.7	1.32 H	150	33.74	18.56
9	#17235.00	40.9 AV	54.0	-13.1	1.32 H	150	22.34	18.56

**ANTENNA POLARITY & TEST DISTANCE: VERTICAL AT 3 M**

NO.	FREQ. (MHz)	EMISSION LEVEL (dBuV/m)	LIMIT (dBuV/m)	MARGIN (dB)	ANTENNA HEIGHT (m)	TABLE ANGLE (Degree)	RAW VALUE (dBuV)	CORRECTION FACTOR (dB/m)
1	#5715.00	69.6 PK	74.0	-4.4	1.00 V	127	65.12	4.48
2	#5715.00	51.8 AV	54.0	-2.2	1.00 V	127	47.32	4.48
<b>3</b>	<b>#5725.00</b>	<b>78.1 PK</b>	<b>78.2</b>	<b>-0.1</b>	<b>1.00 V</b>	<b>127</b>	<b>73.60</b>	<b>4.50</b>
4	*5745.00	110.4 PK			1.00 V	127	105.91	4.49
5	*5745.00	100.0 AV			1.00 V	127	95.51	4.49
6	11490.00	54.7 PK	74.0	-19.3	1.30 V	233	44.66	10.04
7	11490.00	44.2 AV	54.0	-9.8	1.30 V	233	34.16	10.04
8	#17235.00	51.0 PK	74.0	-23.0	1.10 V	136	32.44	18.56
9	#17235.00	42.1 AV	54.0	-11.9	1.10 V	136	23.54	18.56

**REMARKS:**

1. Emission Level(dBuV/m) = Raw Value(dBuV) + Correction Factor(dB/m)
2. Correction Factor(dB/m) = Antenna Factor(dB/m) + Cable Factor(dB) – Pre-Amplifier Factor(dB)
3. The other emission levels were very low against the limit.
4. Margin value = Emission Level – Limit value
5. " \* ": Fundamental frequency.
6. " # ": The radiated frequency is out of the restricted band.

<b>CHANNEL</b>	TX Channel 157	<b>DETECTOR FUNCTION</b>	Peak (PK)
<b>FREQUENCY RANGE</b>	1GHz ~ 40GHz		Average (AV)

**ANTENNA POLARITY & TEST DISTANCE: HORIZONTAL AT 3 M**

NO.	FREQ. (MHz)	EMISSION LEVEL (dBuV/m)	LIMIT (dBuV/m)	MARGIN (dB)	ANTENNA HEIGHT (m)	TABLE ANGLE (Degree)	RAW VALUE (dBuV)	CORRECTION FACTOR (dB/m)
1	#5715.00	61.4 PK	74.0	-12.6	1.02 H	71	56.92	4.48
2	#5715.00	42.0 AV	54.0	-12.0	1.02 H	71	37.52	4.48
3	#5725.00	68.5 PK	78.2	-9.7	1.10 H	65	64.00	4.50
4	*5785.00	105.6 PK			1.11 H	99	101.10	4.50
5	*5785.00	96.0 AV			1.11 H	99	91.50	4.50
6	11570.00	59.3 PK	74.0	-14.7	1.16 H	121	49.22	10.08
7	11570.00	46.6 AV	54.0	-7.4	1.16 H	121	36.52	10.08
8	#17355.00	52.2 PK	74.0	-21.8	1.31 H	144	33.30	18.90
9	#17355.00	40.5 AV	54.0	-13.5	1.31 H	144	21.60	18.90

**ANTENNA POLARITY & TEST DISTANCE: VERTICAL AT 3 M**

NO.	FREQ. (MHz)	EMISSION LEVEL (dBuV/m)	LIMIT (dBuV/m)	MARGIN (dB)	ANTENNA HEIGHT (m)	TABLE ANGLE (Degree)	RAW VALUE (dBuV)	CORRECTION FACTOR (dB/m)
1	#5715.00	73.7 PK	74.0	-0.3	1.06 V	127	69.22	4.48
2	#5715.00	51.1 AV	54.0	-2.9	1.06 V	127	46.62	4.48
3	#5725.00	75.4 PK	78.2	-2.8	1.06 V	127	70.90	4.50
4	*5785.00	115.5 PK			1.06 V	127	111.00	4.50
5	*5785.00	105.4 AV			1.06 V	127	100.90	4.50
6	#5850.00	63.3 PK	78.2	-14.9	1.06 V	127	58.73	4.57
7	#5860.00	62.4 PK	74.0	-11.6	1.06 V	127	57.81	4.59
8	#5860.00	48.2 AV	54.0	-5.8	1.06 V	127	43.61	4.59
9	11570.00	53.9 PK	74.0	-20.1	1.27 V	234	43.82	10.08
10	11570.00	43.4 AV	54.0	-10.6	1.27 V	234	33.32	10.08
11	#17355.00	50.9 PK	74.0	-23.1	1.03 V	132	32.00	18.90
12	#17355.00	41.8 AV	54.0	-12.2	1.03 V	132	22.90	18.90

**REMARKS:**

1. Emission Level(dBuV/m) = Raw Value(dBuV) + Correction Factor(dB/m)
2. Correction Factor(dB/m) = Antenna Factor(dB/m) + Cable Factor(dB) – Pre-Amplifier Factor(dB)
3. The other emission levels were very low against the limit.
4. Margin value = Emission Level – Limit value
5. " \* ": Fundamental frequency.
6. " # ": The radiated frequency is out of the restricted band.

<b>CHANNEL</b>	TX Channel 165	<b>DETECTOR FUNCTION</b>	Peak (PK)
<b>FREQUENCY RANGE</b>	1GHz ~ 40GHz		Average (AV)

**ANTENNA POLARITY & TEST DISTANCE: HORIZONTAL AT 3 M**

NO.	FREQ. (MHz)	EMISSION LEVEL (dBuV/m)	LIMIT (dBuV/m)	MARGIN (dB)	ANTENNA HEIGHT (m)	TABLE ANGLE (Degree)	RAW VALUE (dBuV)	CORRECTION FACTOR (dB/m)
1	*5825.00	104.8 PK			1.01 H	81	100.27	4.53
2	*5825.00	94.6 AV			1.01 H	81	90.07	4.53
3	#5850.00	68.7 PK	78.2	-9.5	1.13 H	99	64.13	4.57
4	#5860.00	61.5 PK	74.0	-12.5	1.13 H	84	56.91	4.59
5	#5860.00	41.7 AV	54.0	-12.3	1.13 H	84	37.11	4.59
6	11650.00	59.5 PK	74.0	-14.5	1.17 H	125	49.53	9.97
7	11650.00	46.8 AV	54.0	-7.2	1.17 H	125	36.83	9.97
8	#17475.00	52.4 PK	74.0	-21.6	1.30 H	127	33.29	19.11
9	#17475.00	40.5 AV	54.0	-13.5	1.30 H	127	21.39	19.11

**ANTENNA POLARITY & TEST DISTANCE: VERTICAL AT 3 M**

NO.	FREQ. (MHz)	EMISSION LEVEL (dBuV/m)	LIMIT (dBuV/m)	MARGIN (dB)	ANTENNA HEIGHT (m)	TABLE ANGLE (Degree)	RAW VALUE (dBuV)	CORRECTION FACTOR (dB/m)
1	*5825.00	113.7 PK			1.05 V	141	109.17	4.53
2	*5825.00	103.6 AV			1.05 V	141	99.07	4.53
3	#5850.00	78.0 PK	78.2	-0.2	1.05 V	141	73.43	4.57
4	#5860.00	72.0 PK	74.0	-2.0	1.05 V	141	67.41	4.59
<b>5</b>	<b>#5860.00</b>	<b>53.9 AV</b>	<b>54.0</b>	<b>-0.1</b>	<b>1.05 V</b>	<b>141</b>	<b>49.31</b>	<b>4.59</b>
6	11650.00	54.1 PK	74.0	-19.9	1.29 V	243	44.13	9.97
7	11650.00	43.7 AV	54.0	-10.3	1.29 V	243	33.73	9.97
8	#17475.00	51.3 PK	74.0	-22.7	1.00 V	128	32.19	19.11
9	#17475.00	41.9 AV	54.0	-12.1	1.00 V	128	22.79	19.11

**REMARKS:**

1. Emission Level(dBuV/m) = Raw Value(dBuV) + Correction Factor(dB/m)
2. Correction Factor(dB/m) = Antenna Factor(dB/m) + Cable Factor(dB) – Pre-Amplifier Factor(dB)
3. The other emission levels were very low against the limit.
4. Margin value = Emission Level – Limit value
5. " \* ": Fundamental frequency.
6. " # ": The radiated frequency is out of the restricted band.

**802.11n (HT40)**

<b>CHANNEL</b>	TX Channel 38	<b>DETECTOR FUNCTION</b>	Peak (PK)
<b>FREQUENCY RANGE</b>	1GHz ~ 40GHz		Average (AV)

**ANTENNA POLARITY & TEST DISTANCE: HORIZONTAL AT 3 M**

NO.	FREQ. (MHz)	EMISSION LEVEL (dBuV/m)	LIMIT (dBuV/m)	MARGIN (dB)	ANTENNA HEIGHT (m)	TABLE ANGLE (Degree)	RAW VALUE (dBuV)	CORRECTION FACTOR (dB/m)
1	5150.00	61.6 PK	74.0	-12.4	1.13 H	86	57.76	3.84
2	5150.00	47.3 AV	54.0	-6.7	1.13 H	86	43.46	3.84
3	*5190.00	96.0 PK			1.13 H	86	92.06	3.94
4	*5190.00	86.4 AV			1.13 H	86	82.46	3.94
5	#10380.00	59.1 PK	74.0	-14.9	1.18 H	119	49.66	9.44
6	#10380.00	46.4 AV	54.0	-7.6	1.18 H	119	36.96	9.44
7	15570.00	52.4 PK	74.0	-21.6	1.26 H	125	38.29	14.11
8	15570.00	40.6 AV	54.0	-13.4	1.26 H	125	26.49	14.11

**ANTENNA POLARITY & TEST DISTANCE: VERTICAL AT 3 M**

NO.	FREQ. (MHz)	EMISSION LEVEL (dBuV/m)	LIMIT (dBuV/m)	MARGIN (dB)	ANTENNA HEIGHT (m)	TABLE ANGLE (Degree)	RAW VALUE (dBuV)	CORRECTION FACTOR (dB/m)
1	5150.00	71.1 PK	74.0	-2.9	1.00 V	135	67.26	3.84
2	5150.00	53.8 AV	54.0	-0.2	1.00 V	135	49.96	3.84
3	*5190.00	105.6 PK			1.00 V	135	101.66	3.94
4	*5190.00	95.4 AV			1.00 V	135	91.46	3.94
5	#10380.00	54.9 PK	74.0	-19.1	1.33 V	254	45.46	9.44
6	#10380.00	43.9 AV	54.0	-10.1	1.33 V	254	34.46	9.44
7	15570.00	53.2 PK	74.0	-20.8	1.00 V	143	39.09	14.11
8	15570.00	40.4 AV	54.0	-13.6	1.00 V	143	26.29	14.11

**REMARKS:**

- Emission Level(dBuV/m) = Raw Value(dBuV) + Correction Factor(dB/m)
- Correction Factor(dB/m) = Antenna Factor(dB/m) + Cable Factor(dB) – Pre-Amplifier Factor(dB)
- The other emission levels were very low against the limit.
- Margin value = Emission Level – Limit value
- " \* ": Fundamental frequency.
- " # ": The radiated frequency is out of the restricted band.



<b>CHANNEL</b>	TX Channel 46	<b>DETECTOR FUNCTION</b>	Peak (PK)
<b>FREQUENCY RANGE</b>	1GHz ~ 40GHz		Average (AV)

**ANTENNA POLARITY & TEST DISTANCE: HORIZONTAL AT 3 M**

NO.	FREQ. (MHz)	EMISSION LEVEL (dBuV/m)	LIMIT (dBuV/m)	MARGIN (dB)	ANTENNA HEIGHT (m)	TABLE ANGLE (Degree)	RAW VALUE (dBuV)	CORRECTION FACTOR (dB/m)
1	5150.00	62.2 PK	74.0	-11.8	1.08 H	94	58.36	3.84
2	5150.00	47.6 AV	54.0	-6.4	1.08 H	94	43.76	3.84
3	*5230.00	101.3 PK			1.08 H	94	97.34	3.96
4	*5230.00	91.4 AV			1.08 H	94	87.44	3.96
5	5350.00	56.9 PK	74.0	-17.1	1.08 H	94	52.83	4.07
6	5350.00	37.2 AV	54.0	-16.8	1.08 H	94	33.13	4.07
7	#10460.00	59.8 PK	74.0	-14.2	1.20 H	133	50.19	9.61
8	#10460.00	46.8 AV	54.0	-7.2	1.20 H	133	37.19	9.61
9	15690.00	52.5 PK	74.0	-21.5	1.22 H	117	38.60	13.90
10	15690.00	40.5 AV	54.0	-13.5	1.22 H	117	26.60	13.90

**ANTENNA POLARITY & TEST DISTANCE: VERTICAL AT 3 M**

NO.	FREQ. (MHz)	EMISSION LEVEL (dBuV/m)	LIMIT (dBuV/m)	MARGIN (dB)	ANTENNA HEIGHT (m)	TABLE ANGLE (Degree)	RAW VALUE (dBuV)	CORRECTION FACTOR (dB/m)
1	5150.00	73.8 PK	74.0	-0.2	1.00 V	140	69.96	3.84
2	5150.00	51.6 AV	54.0	-2.4	1.00 V	140	47.76	3.84
3	*5230.00	113.4 PK			1.00 V	140	109.44	3.96
4	*5230.00	102.7 AV			1.00 V	140	98.74	3.96
5	5350.00	71.1 PK	74.0	-2.9	1.00 V	140	67.03	4.07
6	5350.00	50.2 AV	54.0	-3.8	1.00 V	140	46.13	4.07
7	#10460.00	54.6 PK	74.0	-19.4	1.33 V	255	44.99	9.61
8	#10460.00	44.0 AV	54.0	-10.0	1.33 V	255	34.39	9.61
9	15690.00	52.9 PK	74.0	-21.1	1.00 V	138	39.00	13.90
10	15690.00	40.1 AV	54.0	-13.9	1.00 V	138	26.20	13.90

**REMARKS:**

1. Emission Level(dBuV/m) = Raw Value(dBuV) + Correction Factor(dB/m)
2. Correction Factor(dB/m) = Antenna Factor(dB/m) + Cable Factor(dB) – Pre-Amplifier Factor(dB)
3. The other emission levels were very low against the limit.
4. Margin value = Emission Level – Limit value
5. " \* ": Fundamental frequency.
6. " # ": The radiated frequency is out of the restricted band.



<b>CHANNEL</b>	TX Channel 151	<b>DETECTOR FUNCTION</b>	Peak (PK)
<b>FREQUENCY RANGE</b>	1GHz ~ 40GHz		Average (AV)

**ANTENNA POLARITY & TEST DISTANCE: HORIZONTAL AT 3 M**

NO.	FREQ. (MHz)	EMISSION LEVEL (dBuV/m)	LIMIT (dBuV/m)	MARGIN (dB)	ANTENNA HEIGHT (m)	TABLE ANGLE (Degree)	RAW VALUE (dBuV)	CORRECTION FACTOR (dB/m)
1	#5715.00	61.7 PK	74.0	-12.3	1.07 H	92	57.22	4.48
2	#5715.00	41.9 AV	54.0	-12.1	1.07 H	92	37.42	4.48
3	#5725.00	68.3 PK	78.2	-9.9	1.09 H	112	63.80	4.50
4	*5755.00	95.1 PK			1.00 H	69	90.61	4.49
5	*5755.00	85.4 AV			1.00 H	69	80.91	4.49
6	11510.00	59.0 PK	74.0	-15.0	1.21 H	97	48.95	10.05
7	11510.00	46.7 AV	54.0	-7.3	1.21 H	97	36.65	10.05
8	#17265.00	52.6 PK	74.0	-21.4	1.28 H	128	33.96	18.64
9	#17265.00	40.5 AV	54.0	-13.5	1.28 H	128	21.86	18.64

**ANTENNA POLARITY & TEST DISTANCE: VERTICAL AT 3 M**

NO.	FREQ. (MHz)	EMISSION LEVEL (dBuV/m)	LIMIT (dBuV/m)	MARGIN (dB)	ANTENNA HEIGHT (m)	TABLE ANGLE (Degree)	RAW VALUE (dBuV)	CORRECTION FACTOR (dB/m)
1	#5715.00	71.8 PK	74.0	-2.2	1.04 V	124	67.32	4.48
2	#5715.00	53.6 AV	54.0	-0.4	1.04 V	124	49.12	4.48
3	#5725.00	76.4 PK	78.2	-1.8	1.04 V	124	71.90	4.50
4	*5755.00	104.4 PK			1.04 V	124	99.91	4.49
5	*5755.00	94.1 AV			1.04 V	124	89.61	4.49
6	11510.00	53.5 PK	74.0	-20.5	1.29 V	258	43.45	10.05
7	11510.00	43.3 AV	54.0	-10.7	1.29 V	258	33.25	10.05
8	#17265.00	51.0 PK	74.0	-23.0	1.01 V	125	32.36	18.64
9	#17265.00	41.7 AV	54.0	-12.3	1.01 V	125	23.06	18.64

**REMARKS:**

1. Emission Level(dBuV/m) = Raw Value(dBuV) + Correction Factor(dB/m)
2. Correction Factor(dB/m) = Antenna Factor(dB/m) + Cable Factor(dB) – Pre-Amplifier Factor(dB)
3. The other emission levels were very low against the limit.
4. Margin value = Emission Level – Limit value
5. " \* ": Fundamental frequency.
6. " # ": The radiated frequency is out of the restricted band.

<b>CHANNEL</b>	TX Channel 159	<b>DETECTOR FUNCTION</b>	Peak (PK)
<b>FREQUENCY RANGE</b>	1GHz ~ 40GHz		Average (AV)

**ANTENNA POLARITY & TEST DISTANCE: HORIZONTAL AT 3 M**

NO.	FREQ. (MHz)	EMISSION LEVEL (dBuV/m)	LIMIT (dBuV/m)	MARGIN (dB)	ANTENNA HEIGHT (m)	TABLE ANGLE (Degree)	RAW VALUE (dBuV)	CORRECTION FACTOR (dB/m)
1	*5795.00	101.8 PK			1.00 H	83	97.29	4.51
2	*5795.00	90.4 AV			1.00 H	83	85.89	4.51
3	#5850.00	68.9 PK	78.2	-9.3	1.15 H	93	64.33	4.57
4	#5860.00	62.1 PK	74.0	-11.9	1.13 H	93	57.51	4.59
5	#5860.00	42.1 AV	54.0	-11.9	1.13 H	93	37.51	4.59
6	11590.00	59.2 PK	74.0	-14.8	1.10 H	111	49.11	10.09
7	11590.00	46.6 AV	54.0	-7.4	1.10 H	111	36.51	10.09
8	#17385.00	52.5 PK	74.0	-21.5	1.24 H	146	33.50	19.00
9	#17385.00	40.7 AV	54.0	-13.3	1.24 H	146	21.70	19.00

**ANTENNA POLARITY & TEST DISTANCE: VERTICAL AT 3 M**

NO.	FREQ. (MHz)	EMISSION LEVEL (dBuV/m)	LIMIT (dBuV/m)	MARGIN (dB)	ANTENNA HEIGHT (m)	TABLE ANGLE (Degree)	RAW VALUE (dBuV)	CORRECTION FACTOR (dB/m)
1	*5795.00	110.5 PK			1.00 V	35	105.99	4.51
2	*5795.00	99.5 AV			1.00 V	35	94.99	4.51
3	#5850.00	77.3 PK	78.2	-0.9	1.00 V	35	72.73	4.57
4	#5860.00	73.4 PK	74.0	-0.6	1.00 V	35	68.81	4.59
5	#5860.00	53.3 AV	54.0	-0.7	1.00 V	35	48.71	4.59
6	11590.00	54.2 PK	74.0	-19.8	1.27 V	250	44.11	10.09
7	11590.00	43.8 AV	54.0	-10.2	1.27 V	250	33.71	10.09
8	#17385.00	50.5 PK	74.0	-23.5	1.03 V	144	31.50	19.00
9	#17385.00	41.0 AV	54.0	-13.0	1.03 V	144	22.00	19.00

**REMARKS:**

1. Emission Level(dBuV/m) = Raw Value(dBuV) + Correction Factor(dB/m)
2. Correction Factor(dB/m) = Antenna Factor(dB/m) + Cable Factor(dB) – Pre-Amplifier Factor(dB)
3. The other emission levels were very low against the limit.
4. Margin value = Emission Level – Limit value
5. " \* ": Fundamental frequency.
6. " # ": The radiated frequency is out of the restricted band.

**2TX Mode**
**Above 1GHz Data**
**802.11n (HT20)**

<b>CHANNEL</b>	TX Channel 36	<b>DETECTOR FUNCTION</b>	Peak (PK)
<b>FREQUENCY RANGE</b>	1GHz ~ 40GHz		Average (AV)

<b>ANTENNA POLARITY &amp; TEST DISTANCE: HORIZONTAL AT 3 M</b>								
NO.	FREQ. (MHz)	EMISSION LEVEL (dBuV/m)	LIMIT (dBuV/m)	MARGIN (dB)	ANTENNA HEIGHT (m)	TABLE ANGLE (Degree)	RAW VALUE (dBuV)	CORRECTION FACTOR (dB/m)
1	5150.00	68.1 PK	74.0	-5.9	1.00 H	123	64.26	3.84
2	5150.00	51.9 AV	54.0	-2.1	1.00 H	123	48.06	3.84
3	*5180.00	107.4 PK			1.00 H	123	103.48	3.92
4	*5180.00	95.6 AV			1.00 H	123	91.68	3.92
5	#10360.00	59.0 PK	74.0	-15.0	1.21 H	126	49.57	9.43
6	#10360.00	45.9 AV	54.0	-8.1	1.21 H	126	36.47	9.43
7	15540.00	52.7 PK	74.0	-21.3	1.27 H	150	38.67	14.03
8	15540.00	41.1 AV	54.0	-12.9	1.27 H	150	27.07	14.03

<b>ANTENNA POLARITY &amp; TEST DISTANCE: VERTICAL AT 3 M</b>								
NO.	FREQ. (MHz)	EMISSION LEVEL (dBuV/m)	LIMIT (dBuV/m)	MARGIN (dB)	ANTENNA HEIGHT (m)	TABLE ANGLE (Degree)	RAW VALUE (dBuV)	CORRECTION FACTOR (dB/m)
1	5150.00	72.2 PK	74.0	-1.8	1.13 V	115	68.36	3.84
2	5150.00	53.6 AV	54.0	-0.4	1.13 V	115	49.76	3.84
3	*5180.00	112.4 PK			1.04 V	140	108.48	3.92
4	*5180.00	102.5 AV			1.04 V	140	98.58	3.92
5	#10360.00	55.0 PK	74.0	-19.0	1.33 V	274	45.57	9.43
6	#10360.00	43.3 AV	54.0	-10.7	1.33 V	274	33.87	9.43
7	15540.00	52.4 PK	74.0	-21.6	1.03 V	147	38.37	14.03
8	15540.00	39.7 AV	54.0	-14.3	1.03 V	147	25.67	14.03

**REMARKS:**

- Emission Level(dBuV/m) = Raw Value(dBuV) + Correction Factor(dB/m)
- Correction Factor(dB/m) = Antenna Factor(dB/m) + Cable Factor(dB) – Pre-Amplifier Factor(dB)
- The other emission levels were very low against the limit.
- Margin value = Emission Level – Limit value
- " \* ": Fundamental frequency.
- " # ": The radiated frequency is out of the restricted band.

<b>CHANNEL</b>	TX Channel 40	<b>DETECTOR FUNCTION</b>	Peak (PK)
<b>FREQUENCY RANGE</b>	1GHz ~ 40GHz		Average (AV)

**ANTENNA POLARITY & TEST DISTANCE: HORIZONTAL AT 3 M**

NO.	FREQ. (MHz)	EMISSION LEVEL (dBuV/m)	LIMIT (dBuV/m)	MARGIN (dB)	ANTENNA HEIGHT (m)	TABLE ANGLE (Degree)	RAW VALUE (dBuV)	CORRECTION FACTOR (dB/m)
1	5150.00	73.0 PK	74.0	-1.0	1.05 H	128	69.16	3.84
2	5150.00	50.0 AV	54.0	-4.0	1.05 H	128	46.16	3.84
3	*5200.00	113.6 PK			1.05 H	128	109.64	3.96
4	*5200.00	101.9 AV			1.05 H	128	97.94	3.96
5	#10400.00	58.7 PK	74.0	-15.3	1.20 H	126	49.25	9.45
6	#10400.00	46.3 AV	54.0	-7.7	1.20 H	126	36.85	9.45
7	15600.00	52.4 PK	74.0	-21.6	1.25 H	146	38.22	14.18
8	15600.00	40.9 AV	54.0	-13.1	1.25 H	146	26.72	14.18

**ANTENNA POLARITY & TEST DISTANCE: VERTICAL AT 3 M**

NO.	FREQ. (MHz)	EMISSION LEVEL (dBuV/m)	LIMIT (dBuV/m)	MARGIN (dB)	ANTENNA HEIGHT (m)	TABLE ANGLE (Degree)	RAW VALUE (dBuV)	CORRECTION FACTOR (dB/m)
1	5150.00	73.5 PK	74.0	-0.5	1.05 V	127	69.66	3.84
2	5150.00	50.5 AV	54.0	-3.5	1.05 V	127	46.66	3.84
3	*5200.00	118.4 PK			1.05 V	127	114.44	3.96
4	*5200.00	108.7 AV			1.05 V	127	104.74	3.96
5	#10400.00	55.0 PK	74.0	-19.0	1.36 V	276	45.55	9.45
6	#10400.00	43.0 AV	54.0	-11.0	1.36 V	276	33.55	9.45
7	15600.00	51.8 PK	74.0	-22.2	1.07 V	152	37.62	14.18
8	15600.00	39.1 AV	54.0	-14.9	1.07 V	152	24.92	14.18

**REMARKS:**

1. Emission Level(dBuV/m) = Raw Value(dBuV) + Correction Factor(dB/m)
2. Correction Factor(dB/m) = Antenna Factor(dB/m) + Cable Factor(dB) – Pre-Amplifier Factor(dB)
3. The other emission levels were very low against the limit.
4. Margin value = Emission Level – Limit value
5. " \* ": Fundamental frequency.
6. " # ": The radiated frequency is out of the restricted band.

<b>CHANNEL</b>	TX Channel 48	<b>DETECTOR FUNCTION</b>	Peak (PK)
<b>FREQUENCY RANGE</b>	1GHz ~ 40GHz		Average (AV)

**ANTENNA POLARITY & TEST DISTANCE: HORIZONTAL AT 3 M**

NO.	FREQ. (MHz)	EMISSION LEVEL (dBuV/m)	LIMIT (dBuV/m)	MARGIN (dB)	ANTENNA HEIGHT (m)	TABLE ANGLE (Degree)	RAW VALUE (dBuV)	CORRECTION FACTOR (dB/m)
1	5150.00	65.5 PK	74.0	-8.5	1.03 H	134	61.66	3.84
2	5150.00	49.6 AV	54.0	-4.4	1.03 H	134	45.76	3.84
3	*5240.00	116.3 PK			1.03 H	134	112.35	3.95
4	*5240.00	104.4 AV			1.03 H	134	100.45	3.95
5	5350.00	55.4 PK	74.0	-18.6	1.03 H	134	51.33	4.07
6	5350.00	37.8 AV	54.0	-16.2	1.03 H	134	33.73	4.07
7	#10480.00	59.1 PK	74.0	-14.9	1.19 H	117	49.43	9.67
8	#10480.00	46.6 AV	54.0	-7.4	1.19 H	117	36.93	9.67
9	15720.00	52.7 PK	74.0	-21.3	1.29 H	141	38.81	13.89
10	15720.00	40.9 AV	54.0	-13.1	1.29 H	141	27.01	13.89

**ANTENNA POLARITY & TEST DISTANCE: VERTICAL AT 3 M**

NO.	FREQ. (MHz)	EMISSION LEVEL (dBuV/m)	LIMIT (dBuV/m)	MARGIN (dB)	ANTENNA HEIGHT (m)	TABLE ANGLE (Degree)	RAW VALUE (dBuV)	CORRECTION FACTOR (dB/m)
1	5150.00	66.3 PK	74.0	-7.7	1.12 V	114	62.46	3.84
2	5150.00	50.2 AV	54.0	-3.8	1.12 V	114	46.36	3.84
3	*5240.00	121.8 PK			1.12 V	114	117.85	3.95
4	*5240.00	110.8 AV			1.12 V	114	106.85	3.95
5	5350.00	55.7 PK	74.0	-18.3	1.12 V	114	51.63	4.07
6	5350.00	38.1 AV	54.0	-15.9	1.12 V	114	34.03	4.07
7	#10480.00	55.2 PK	74.0	-18.8	1.36 V	261	45.53	9.67
8	#10480.00	43.8 AV	54.0	-10.2	1.36 V	261	34.13	9.67
9	15720.00	52.3 PK	74.0	-21.7	1.06 V	142	38.41	13.89
10	15720.00	39.5 AV	54.0	-14.5	1.06 V	142	25.61	13.89

**REMARKS:**

1. Emission Level(dBuV/m) = Raw Value(dBuV) + Correction Factor(dB/m)
2. Correction Factor(dB/m) = Antenna Factor(dB/m) + Cable Factor(dB) – Pre-Amplifier Factor(dB)
3. The other emission levels were very low against the limit.
4. Margin value = Emission Level – Limit value
5. " \* ": Fundamental frequency.
6. " # ": The radiated frequency is out of the restricted band.

<b>CHANNEL</b>	TX Channel 149	<b>DETECTOR FUNCTION</b>	Peak (PK)
<b>FREQUENCY RANGE</b>	1GHz ~ 40GHz		Average (AV)

**ANTENNA POLARITY & TEST DISTANCE: HORIZONTAL AT 3 M**

NO.	FREQ. (MHz)	EMISSION LEVEL (dBuV/m)	LIMIT (dBuV/m)	MARGIN (dB)	ANTENNA HEIGHT (m)	TABLE ANGLE (Degree)	RAW VALUE (dBuV)	CORRECTION FACTOR (dB/m)
1	#5715.00	62.0 PK	74.0	-12.0	1.05 H	83	57.52	4.48
2	#5715.00	42.5 AV	54.0	-11.5	1.05 H	83	38.02	4.48
3	#5725.00	68.1 PK	78.2	-10.1	1.08 H	65	63.60	4.50
4	*5745.00	102.9 PK			1.06 H	84	98.41	4.49
5	*5745.00	92.8 AV			1.06 H	84	88.31	4.49
6	11490.00	58.6 PK	74.0	-15.4	1.19 H	107	48.56	10.04
7	11490.00	46.0 AV	54.0	-8.0	1.19 H	107	35.96	10.04
8	#17235.00	52.2 PK	74.0	-21.8	1.24 H	146	33.64	18.56
9	#17235.00	40.4 AV	54.0	-13.6	1.24 H	146	21.84	18.56

**ANTENNA POLARITY & TEST DISTANCE: VERTICAL AT 3 M**

NO.	FREQ. (MHz)	EMISSION LEVEL (dBuV/m)	LIMIT (dBuV/m)	MARGIN (dB)	ANTENNA HEIGHT (m)	TABLE ANGLE (Degree)	RAW VALUE (dBuV)	CORRECTION FACTOR (dB/m)
1	#5715.00	70.1 PK	74.0	-3.9	1.00 V	101	65.62	4.48
2	#5715.00	49.4 AV	54.0	-4.6	1.00 V	101	44.92	4.48
<b>3</b>	<b>#5725.00</b>	<b>78.1 PK</b>	<b>78.2</b>	<b>-0.1</b>	<b>1.00 V</b>	<b>101</b>	<b>73.60</b>	<b>4.50</b>
4	*5745.00	111.8 PK			1.00 V	101	107.31	4.49
5	*5745.00	101.4 AV			1.00 V	101	96.91	4.49
6	11490.00	54.6 PK	74.0	-19.4	1.36 V	245	44.56	10.04
7	11490.00	44.0 AV	54.0	-10.0	1.36 V	245	33.96	10.04
8	#17235.00	50.6 PK	74.0	-23.4	1.09 V	146	32.04	18.56
9	#17235.00	41.1 AV	54.0	-12.9	1.09 V	146	22.54	18.56

**REMARKS:**

1. Emission Level(dBuV/m) = Raw Value(dBuV) + Correction Factor(dB/m)
2. Correction Factor(dB/m) = Antenna Factor(dB/m) + Cable Factor(dB) – Pre-Amplifier Factor(dB)
3. The other emission levels were very low against the limit.
4. Margin value = Emission Level – Limit value
5. " \* ": Fundamental frequency.
6. " # ": The radiated frequency is out of the restricted band.

<b>CHANNEL</b>	TX Channel 157	<b>DETECTOR FUNCTION</b>	Peak (PK)
<b>FREQUENCY RANGE</b>	1GHz ~ 40GHz		Average (AV)

**ANTENNA POLARITY & TEST DISTANCE: HORIZONTAL AT 3 M**

NO.	FREQ. (MHz)	EMISSION LEVEL (dBuV/m)	LIMIT (dBuV/m)	MARGIN (dB)	ANTENNA HEIGHT (m)	TABLE ANGLE (Degree)	RAW VALUE (dBuV)	CORRECTION FACTOR (dB/m)
1	#5715.00	61.3 PK	74.0	-12.7	1.10 H	85	56.82	4.48
2	#5715.00	41.8 AV	54.0	-12.2	1.10 H	85	37.32	4.48
3	#5725.00	67.9 PK	78.2	-10.3	1.13 H	95	63.40	4.50
4	*5785.00	106.7 PK			1.09 H	91	102.20	4.50
5	*5785.00	96.8 AV			1.09 H	91	92.30	4.50
6	11570.00	58.2 PK	74.0	-15.8	1.23 H	122	48.12	10.08
7	11570.00	46.0 AV	54.0	-8.0	1.23 H	122	35.92	10.08
8	#17355.00	52.8 PK	74.0	-21.2	1.29 H	146	33.90	18.90
9	#17355.00	40.9 AV	54.0	-13.1	1.29 H	146	22.00	18.90

**ANTENNA POLARITY & TEST DISTANCE: VERTICAL AT 3 M**

NO.	FREQ. (MHz)	EMISSION LEVEL (dBuV/m)	LIMIT (dBuV/m)	MARGIN (dB)	ANTENNA HEIGHT (m)	TABLE ANGLE (Degree)	RAW VALUE (dBuV)	CORRECTION FACTOR (dB/m)
1	#5715.00	73.9 PK	74.0	-0.1	1.00 V	101	69.42	4.48
2	#5715.00	51.6 AV	54.0	-2.4	1.00 V	101	47.12	4.48
3	#5725.00	75.4 PK	78.2	-2.8	1.00 V	101	70.90	4.50
4	*5785.00	115.9 PK			1.00 V	101	111.40	4.50
5	*5785.00	105.9 AV			1.00 V	101	101.40	4.50
6	#5850.00	61.5 PK	78.2	-16.7	1.00 V	101	56.93	4.57
7	#5860.00	58.1 PK	74.0	-15.9	1.00 V	101	53.51	4.59
8	#5860.00	43.4 AV	54.0	-10.6	1.00 V	101	38.81	4.59
9	11570.00	54.1 PK	74.0	-19.9	1.21 V	253	44.02	10.08
10	11570.00	43.6 AV	54.0	-10.4	1.21 V	253	33.52	10.08
11	#17355.00	50.2 PK	74.0	-23.8	1.09 V	141	31.30	18.90
12	#17355.00	41.4 AV	54.0	-12.6	1.09 V	141	22.50	18.90

**REMARKS:**

1. Emission Level(dBuV/m) = Raw Value(dBuV) + Correction Factor(dB/m)
2. Correction Factor(dB/m) = Antenna Factor(dB/m) + Cable Factor(dB) – Pre-Amplifier Factor(dB)
3. The other emission levels were very low against the limit.
4. Margin value = Emission Level – Limit value
5. " \* ": Fundamental frequency.
6. " # ": The radiated frequency is out of the restricted band.

<b>CHANNEL</b>	TX Channel 165	<b>DETECTOR FUNCTION</b>	Peak (PK)
<b>FREQUENCY RANGE</b>	1GHz ~ 40GHz		Average (AV)

**ANTENNA POLARITY & TEST DISTANCE: HORIZONTAL AT 3 M**

NO.	FREQ. (MHz)	EMISSION LEVEL (dBuV/m)	LIMIT (dBuV/m)	MARGIN (dB)	ANTENNA HEIGHT (m)	TABLE ANGLE (Degree)	RAW VALUE (dBuV)	CORRECTION FACTOR (dB/m)
1	*5825.00	105.1 PK			1.03 H	77	100.57	4.53
2	*5825.00	94.7 AV			1.03 H	77	90.17	4.53
3	#5850.00	67.6 PK	78.2	-10.6	1.07 H	68	63.03	4.57
4	#5860.00	62.4 PK	74.0	-11.6	1.09 H	95	57.81	4.59
5	#5860.00	42.7 AV	54.0	-11.3	1.09 H	95	38.11	4.59
6	11650.00	58.0 PK	74.0	-16.0	1.14 H	95	48.03	9.97
7	11650.00	45.8 AV	54.0	-8.2	1.14 H	95	35.83	9.97
8	#17475.00	52.8 PK	74.0	-21.2	1.31 H	152	33.69	19.11
9	#17475.00	40.9 AV	54.0	-13.1	1.31 H	152	21.79	19.11

**ANTENNA POLARITY & TEST DISTANCE: VERTICAL AT 3 M**

NO.	FREQ. (MHz)	EMISSION LEVEL (dBuV/m)	LIMIT (dBuV/m)	MARGIN (dB)	ANTENNA HEIGHT (m)	TABLE ANGLE (Degree)	RAW VALUE (dBuV)	CORRECTION FACTOR (dB/m)
1	*5825.00	113.7 PK			1.05 V	78	109.17	4.53
2	*5825.00	103.5 AV			1.05 V	78	98.97	4.53
3	#5850.00	77.7 PK	78.2	-0.5	1.18 V	85	73.13	4.57
4	#5860.00	69.2 PK	74.0	-4.8	1.18 V	82	64.61	4.59
5	#5860.00	51.3 AV	54.0	-2.7	1.18 V	82	46.71	4.59
6	11650.00	54.2 PK	74.0	-19.8	1.28 V	268	44.23	9.97
7	11650.00	43.4 AV	54.0	-10.6	1.28 V	268	33.43	9.97
8	#17475.00	50.8 PK	74.0	-23.2	1.05 V	141	31.69	19.11
9	#17475.00	41.6 AV	54.0	-12.4	1.05 V	141	22.49	19.11

**REMARKS:**

1. Emission Level(dBuV/m) = Raw Value(dBuV) + Correction Factor(dB/m)
2. Correction Factor(dB/m) = Antenna Factor(dB/m) + Cable Factor(dB) – Pre-Amplifier Factor(dB)
3. The other emission levels were very low against the limit.
4. Margin value = Emission Level – Limit value
5. " \* ": Fundamental frequency.
6. " # ": The radiated frequency is out of the restricted band.



**802.11n (HT40)**

<b>CHANNEL</b>	TX Channel 38	<b>DETECTOR FUNCTION</b>	Peak (PK)
<b>FREQUENCY RANGE</b>	1GHz ~ 40GHz		Average (AV)

**ANTENNA POLARITY & TEST DISTANCE: HORIZONTAL AT 3 M**

NO.	FREQ. (MHz)	EMISSION LEVEL (dBuV/m)	LIMIT (dBuV/m)	MARGIN (dB)	ANTENNA HEIGHT (m)	TABLE ANGLE (Degree)	RAW VALUE (dBuV)	CORRECTION FACTOR (dB/m)
1	5150.00	67.7 PK	74.0	-6.3	1.08 H	126	63.86	3.84
2	5150.00	51.7 AV	54.0	-2.3	1.08 H	126	47.86	3.84
3	*5190.00	100.0 PK			1.08 H	126	96.06	3.94
4	*5190.00	89.8 AV			1.08 H	126	85.86	3.94
5	#10380.00	59.3 PK	74.0	-14.7	1.21 H	111	49.86	9.44
6	#10380.00	46.0 AV	54.0	-8.0	1.21 H	111	36.56	9.44
7	15570.00	51.9 PK	74.0	-22.1	1.24 H	144	37.79	14.11
8	15570.00	40.4 AV	54.0	-13.6	1.24 H	144	26.29	14.11

**ANTENNA POLARITY & TEST DISTANCE: VERTICAL AT 3 M**

NO.	FREQ. (MHz)	EMISSION LEVEL (dBuV/m)	LIMIT (dBuV/m)	MARGIN (dB)	ANTENNA HEIGHT (m)	TABLE ANGLE (Degree)	RAW VALUE (dBuV)	CORRECTION FACTOR (dB/m)
1	5150.00	71.6 PK	74.0	-2.4	1.00 V	78	67.76	3.84
2	<b>5150.00</b>	<b>53.9 AV</b>	<b>54.0</b>	<b>-0.1</b>	<b>1.00 V</b>	<b>78</b>	<b>50.06</b>	<b>3.84</b>
3	*5190.00	106.2 PK			1.00 V	150	102.26	3.94
4	*5190.00	96.3 AV			1.00 V	150	92.36	3.94
5	#10380.00	55.2 PK	74.0	-18.8	1.38 V	246	45.76	9.44
6	#10380.00	44.0 AV	54.0	-10.0	1.38 V	246	34.56	9.44
7	15570.00	52.7 PK	74.0	-21.3	1.00 V	135	38.59	14.11
8	15570.00	39.9 AV	54.0	-14.1	1.00 V	135	25.79	14.11

**REMARKS:**

- Emission Level(dBuV/m) = Raw Value(dBuV) + Correction Factor(dB/m)
- Correction Factor(dB/m) = Antenna Factor(dB/m) + Cable Factor(dB) – Pre-Amplifier Factor(dB)
- The other emission levels were very low against the limit.
- Margin value = Emission Level – Limit value
- " \* ": Fundamental frequency.
- " # ": The radiated frequency is out of the restricted band.

<b>CHANNEL</b>	TX Channel 46	<b>DETECTOR FUNCTION</b>	Peak (PK)
<b>FREQUENCY RANGE</b>	1GHz ~ 40GHz		Average (AV)

**ANTENNA POLARITY & TEST DISTANCE: HORIZONTAL AT 3 M**

NO.	FREQ. (MHz)	EMISSION LEVEL (dBuV/m)	LIMIT (dBuV/m)	MARGIN (dB)	ANTENNA HEIGHT (m)	TABLE ANGLE (Degree)	RAW VALUE (dBuV)	CORRECTION FACTOR (dB/m)
1	5150.00	73.1 PK	74.0	-0.9	1.09 H	135	69.26	3.84
2	5150.00	50.1 AV	54.0	-3.9	1.09 H	135	46.26	3.84
3	*5230.00	107.1 PK			1.09 H	135	103.14	3.96
4	*5230.00	96.6 AV			1.09 H	135	92.64	3.96
5	5350.00	65.6 PK	74.0	-8.4	1.09 H	135	61.53	4.07
6	5350.00	46.7 AV	54.0	-7.3	1.09 H	135	42.63	4.07
7	#10460.00	59.7 PK	74.0	-14.3	1.20 H	112	50.09	9.61
8	#10460.00	45.9 AV	54.0	-8.1	1.20 H	112	36.29	9.61
9	15690.00	52.2 PK	74.0	-21.8	1.24 H	148	38.30	13.90
10	15690.00	40.5 AV	54.0	-13.5	1.24 H	148	26.60	13.90

**ANTENNA POLARITY & TEST DISTANCE: VERTICAL AT 3 M**

NO.	FREQ. (MHz)	EMISSION LEVEL (dBuV/m)	LIMIT (dBuV/m)	MARGIN (dB)	ANTENNA HEIGHT (m)	TABLE ANGLE (Degree)	RAW VALUE (dBuV)	CORRECTION FACTOR (dB/m)
1	5150.00	73.4 PK	74.0	-0.6	1.12 V	114	69.56	3.84
2	5150.00	53.5 AV	54.0	-0.5	1.12 V	114	49.66	3.84
3	*5230.00	113.9 PK			1.12 V	114	109.94	3.96
4	*5230.00	103.3 AV			1.12 V	114	99.34	3.96
5	5350.00	67.8 PK	74.0	-6.2	1.12 V	114	63.73	4.07
6	5350.00	48.2 AV	54.0	-5.8	1.12 V	114	44.13	4.07
7	#10460.00	55.0 PK	74.0	-19.0	1.40 V	245	45.39	9.61
8	#10460.00	43.3 AV	54.0	-10.7	1.40 V	245	33.69	9.61
9	15690.00	52.1 PK	74.0	-21.9	1.06 V	145	38.20	13.90
10	15690.00	39.3 AV	54.0	-14.7	1.06 V	145	25.40	13.90

**REMARKS:**

- Emission Level(dBuV/m) = Raw Value(dBuV) + Correction Factor(dB/m)
- Correction Factor(dB/m) = Antenna Factor(dB/m) + Cable Factor(dB) – Pre-Amplifier Factor(dB)
- The other emission levels were very low against the limit.
- Margin value = Emission Level – Limit value
- " \* ": Fundamental frequency.
- " # ": The radiated frequency is out of the restricted band.

<b>CHANNEL</b>	TX Channel 151	<b>DETECTOR FUNCTION</b>	Peak (PK)
<b>FREQUENCY RANGE</b>	1GHz ~ 40GHz		Average (AV)

**ANTENNA POLARITY & TEST DISTANCE: HORIZONTAL AT 3 M**

NO.	FREQ. (MHz)	EMISSION LEVEL (dBuV/m)	LIMIT (dBuV/m)	MARGIN (dB)	ANTENNA HEIGHT (m)	TABLE ANGLE (Degree)	RAW VALUE (dBuV)	CORRECTION FACTOR (dB/m)
1	#5715.00	61.9 PK	74.0	-12.1	1.06 H	74	57.42	4.48
2	#5715.00	42.3 AV	54.0	-11.7	1.06 H	74	37.82	4.48
3	#5725.00	63.5 PK	78.2	-14.7	1.13 H	60	59.00	4.50
4	*5755.00	95.2 PK			1.09 H	80	90.71	4.49
5	*5755.00	86.6 AV			1.09 H	80	82.11	4.49
6	11510.00	58.1 PK	74.0	-15.9	1.16 H	111	48.05	10.05
7	11510.00	46.1 AV	54.0	-7.9	1.16 H	111	36.05	10.05
8	#17265.00	52.6 PK	74.0	-21.4	1.26 H	127	33.96	18.64
9	#17265.00	40.5 AV	54.0	-13.5	1.26 H	127	21.86	18.64

**ANTENNA POLARITY & TEST DISTANCE: VERTICAL AT 3 M**

NO.	FREQ. (MHz)	EMISSION LEVEL (dBuV/m)	LIMIT (dBuV/m)	MARGIN (dB)	ANTENNA HEIGHT (m)	TABLE ANGLE (Degree)	RAW VALUE (dBuV)	CORRECTION FACTOR (dB/m)
1	#5715.00	69.7 PK	74.0	-4.3	1.02 V	105	65.22	4.48
2	#5715.00	53.9 AV	54.0	-0.1	1.02 V	105	49.42	4.48
3	#5725.00	70.2 PK	78.2	-8.0	1.02 V	105	65.70	4.50
4	*5755.00	106.3 PK			1.02 V	105	101.81	4.49
5	*5755.00	95.8 AV			1.02 V	105	91.31	4.49
6	11510.00	54.1 PK	74.0	-19.9	1.30 V	257	44.05	10.05
7	11510.00	43.8 AV	54.0	-10.2	1.30 V	257	33.75	10.05
8	#17265.00	49.9 PK	74.0	-24.1	1.00 V	143	31.26	18.64
9	#17265.00	41.4 AV	54.0	-12.6	1.00 V	143	22.76	18.64

**REMARKS:**

1. Emission Level(dBuV/m) = Raw Value(dBuV) + Correction Factor(dB/m)
2. Correction Factor(dB/m) = Antenna Factor(dB/m) + Cable Factor(dB) – Pre-Amplifier Factor(dB)
3. The other emission levels were very low against the limit.
4. Margin value = Emission Level – Limit value
5. " \* ": Fundamental frequency.
6. " # ": The radiated frequency is out of the restricted band.

<b>CHANNEL</b>	TX Channel 159	<b>DETECTOR FUNCTION</b>	Peak (PK)
<b>FREQUENCY RANGE</b>	1GHz ~ 40GHz		Average (AV)

**ANTENNA POLARITY & TEST DISTANCE: HORIZONTAL AT 3 M**

NO.	FREQ. (MHz)	EMISSION LEVEL (dBuV/m)	LIMIT (dBuV/m)	MARGIN (dB)	ANTENNA HEIGHT (m)	TABLE ANGLE (Degree)	RAW VALUE (dBuV)	CORRECTION FACTOR (dB/m)
1	*5795.00	103.1 PK			1.05 H	88	98.59	4.51
2	*5795.00	93.1 AV			1.05 H	88	88.59	4.51
3	#5850.00	67.8 PK	78.2	-10.4	1.03 H	75	63.23	4.57
4	#5860.00	62.1 PK	74.0	-11.9	1.07 H	97	57.51	4.59
5	#5860.00	42.6 AV	54.0	-11.4	1.07 H	97	38.01	4.59
6	11590.00	58.6 PK	74.0	-15.4	1.23 H	86	48.51	10.09
7	11590.00	46.3 AV	54.0	-7.7	1.23 H	86	36.21	10.09
8	#17385.00	53.0 PK	74.0	-21.0	1.23 H	110	34.00	19.00
9	#17385.00	41.1 AV	54.0	-12.9	1.23 H	110	22.10	19.00

**ANTENNA POLARITY & TEST DISTANCE: VERTICAL AT 3 M**

NO.	FREQ. (MHz)	EMISSION LEVEL (dBuV/m)	LIMIT (dBuV/m)	MARGIN (dB)	ANTENNA HEIGHT (m)	TABLE ANGLE (Degree)	RAW VALUE (dBuV)	CORRECTION FACTOR (dB/m)
1	*5795.00	112.5 PK			1.38 V	92	107.99	4.51
2	*5795.00	102.1 AV			1.38 V	92	97.59	4.51
3	#5850.00	75.1 PK	78.2	-3.1	1.38 V	92	70.53	4.57
4	#5860.00	71.2 PK	74.0	-2.8	1.38 V	92	66.61	4.59
5	#5860.00	53.8 AV	54.0	-0.2	1.38 V	92	49.21	4.59
6	11590.00	54.2 PK	74.0	-19.8	1.23 V	253	44.11	10.09
7	11590.00	44.2 AV	54.0	-9.8	1.23 V	253	34.11	10.09
8	#17385.00	50.8 PK	74.0	-23.2	1.05 V	135	31.80	19.00
9	#17385.00	41.7 AV	54.0	-12.3	1.05 V	135	22.70	19.00

**REMARKS:**

1. Emission Level(dBuV/m) = Raw Value(dBuV) + Correction Factor(dB/m)
2. Correction Factor(dB/m) = Antenna Factor(dB/m) + Cable Factor(dB) – Pre-Amplifier Factor(dB)
3. The other emission levels were very low against the limit.
4. Margin value = Emission Level – Limit value
5. " \* ": Fundamental frequency.
6. " # ": The radiated frequency is out of the restricted band.

**Below 1GHz Data**
**802.11n (HT20)**

<b>CHANNEL</b>	TX Channel 48	<b>DETECTOR FUNCTION</b>	Quasi-Peak (QP)
<b>FREQUENCY RANGE</b>	Below 1GHz		

**ANTENNA POLARITY & TEST DISTANCE: HORIZONTAL AT 3 M**

NO.	FREQ. (MHz)	EMISSION LEVEL (dBuV/m)	LIMIT (dBuV/m)	MARGIN (dB)	ANTENNA HEIGHT (m)	TABLE ANGLE (Degree)	RAW VALUE (dBuV)	CORRECTION FACTOR (dB/m)
1	126.34	34.2 QP	43.5	-9.3	1.00 H	310	48.79	-14.60
2	250.99	40.8 QP	46.0	-5.2	1.50 H	4	54.65	-13.86
3	376.98	38.1 QP	46.0	-7.9	1.50 H	119	48.28	-10.19
4	503.01	39.9 QP	46.0	-6.1	1.50 H	247	47.00	-7.07
5	626.99	41.5 QP	46.0	-4.5	1.00 H	203	45.73	-4.24
6	874.97	40.2 QP	46.0	-5.8	1.50 H	135	40.59	-0.36

**ANTENNA POLARITY & TEST DISTANCE: VERTICAL AT 3 M**

NO.	FREQ. (MHz)	EMISSION LEVEL (dBuV/m)	LIMIT (dBuV/m)	MARGIN (dB)	ANTENNA HEIGHT (m)	TABLE ANGLE (Degree)	RAW VALUE (dBuV)	CORRECTION FACTOR (dB/m)
1	63.50	35.5 QP	40.0	-4.5	1.50 V	208	49.81	-14.33
2	73.41	36.5 QP	40.0	-3.5	1.50 V	316	52.61	-16.10
3	125.01	39.6 QP	43.5	-3.9	1.00 V	139	54.21	-14.62
4	260.00	39.4 QP	46.0	-6.6	1.00 V	169	53.06	-13.62
5	533.23	41.3 QP	46.0	-4.7	1.00 V	135	47.91	-6.59
6	625.01	42.4 QP	46.0	-3.6	1.37 V	135	46.68	-4.31

**REMARKS:**

1. Emission Level(dBuV/m) = Raw Value(dBuV) + Correction Factor(dB/m)
2. Correction Factor(dB/m) = Antenna Factor(dB/m) + Cable Factor(dB) – Pre-Amplifier Factor(dB)
3. The other emission levels were very low against the limit.
4. Margin value = Emission Level – Limit value

## 4.2 Conducted Emission Measurement

### 4.2.1 Limits of Conducted Emission Measurement

Frequency (MHz)	Conducted Limit (dBuV)	
	Quasi-peak	Average
0.15 - 0.5	66 - 56	56 - 46
0.50 - 5.0	56	46
5.0 - 30.0	60	50

Note: 1. The lower limit shall apply at the transition frequencies.

2. The limit decreases in line with the logarithm of the frequency in the range of 0.15 to 0.50MHz.

### 4.2.2 Test Instruments

DESCRIPTION & MANUFACTURER	MODEL NO.	SERIAL NO.	CALIBRATED DATE	CALIBRATED UNTIL
Test Receiver ROHDE & SCHWARZ	ESCS 30	100375	Apr. 29, 2014	Apr. 28, 2015
Line-Impedance Stabilization Network (for EUT) SCHWARZBECK	NSLK-8127	8127-522	Sep. 15, 2014	Sep. 14, 2015
Line-Impedance Stabilization Network (for Peripheral) ROHDE & SCHWARZ	ENV216	100071	Nov. 10, 2014	Nov. 09, 2015
RF Cable (JYEBAO)	5D-FB	COCCAB-001	Mar. 09, 2015	Mar. 08, 2016
50 ohms Terminator	N/A	EMC-03	Sep. 22, 2014	Sep. 21, 2015
50 ohms Terminator	N/A	EMC-02	Sep. 30, 2014	Sep. 29, 2015
Software ADT	BV ADT_Cond_V7.3.7 .3	NA	NA	NA

**Note:**

1. The calibration interval of the above test instruments is 12 months and the calibrations are traceable to NML/ROC and NIST/USA.
2. The test was performed in Shielded Room No. C.
3. The VCCI Con C Registration No. is C-3611.
4. Tested Date: Mar. 25, 2015

#### 4.2.3 Test Procedure

- a. The EUT was placed 0.4 meters from the conducting wall of the shielded room with EUT being connected to the power mains through a line impedance stabilization network (LISN). Other support units were connected to the power mains through another LISN. The two LISNs provide 50 ohm/ 50uH of coupling impedance for the measuring instrument.
- b. Both lines of the power mains connected to the EUT were checked for maximum conducted interference.
- c. The frequency range from 150kHz to 30MHz was searched. Emission levels under (Limit - 20dB) was not recorded.

**NOTE:** All modes of operation were investigated and the worst-case emissions are reported.

#### 4.2.4 Deviation from Test Standard

No deviation.

#### 4.2.5 Test Setup

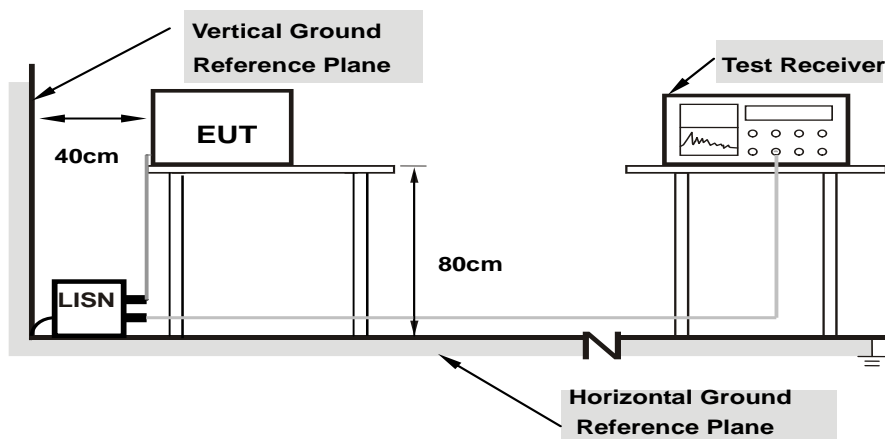

For the actual test configuration, please refer to the attached file (Test Setup Photo).

#### 4.2.6 EUT Operating Condition

Same as 4.1.6.

4.2.7 Test Results (Mode 1)

Phase	Line (L)	Detector Function	Quasi-Peak (QP) / Average (AV)
-------	----------	-------------------	--------------------------------

No	Freq. [MHz]	Corr.	Reading Value		Emission Level		Limit		Margin	
		Factor	[dB (uV)]		[dB (uV)]		[dB (uV)]		(dB)	
	(dB)	Q.P.	AV.	Q.P.	AV.	Q.P.	AV.	Q.P.	AV.	
1	0.15000	0.08	48.19	37.22	48.27	37.30	66.00	56.00	-17.73	-18.70
2	0.19297	0.09	45.03	37.71	45.12	37.80	63.91	53.91	-18.79	-16.11
3	0.27500	0.09	45.29	40.88	45.38	40.97	60.97	50.97	-15.58	-9.99
4	0.30234	0.10	43.12	39.39	43.22	39.49	60.18	50.18	-16.96	-10.69
5	0.32578	0.10	42.49	39.44	42.59	39.54	59.56	49.56	-16.97	-10.02
6	10.29297	0.46	24.67	20.82	25.13	21.28	60.00	50.00	-34.87	-28.72

REMARKS:

1. Q.P. and AV. are abbreviations of quasi-peak and average individually.
2. The emission levels of other frequencies were very low against the limit.
3. Margin value = Emission level - Limit value
4. Correction factor = Insertion loss + Cable loss
5. Emission Level = Correction Factor + Reading Value.

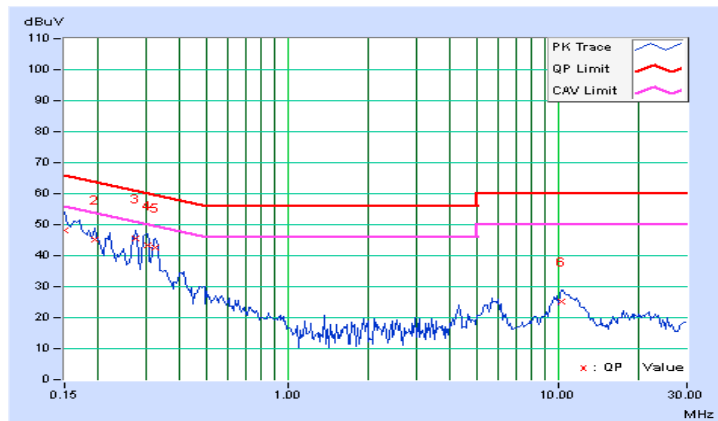



Phase	Neutral (N)	Detector Function	Quasi-Peak (QP) / Average (AV)
-------	-------------	-------------------	--------------------------------

No	Freq. [MHz]	Corr.	Reading Value		Emission Level		Limit		Margin	
		Factor	[dB (uV)]		[dB (uV)]		[dB (uV)]		(dB)	
	(dB)	Q.P.	AV.	Q.P.	AV.	Q.P.	AV.	Q.P.	AV.	
1	0.15000	0.08	48.99	37.56	49.07	37.64	66.00	56.00	-16.93	-18.36
2	0.16562	0.08	48.18	39.71	48.26	39.79	65.18	55.18	-16.92	-15.39
3	0.18906	0.08	45.75	39.11	45.83	39.19	64.08	54.08	-18.25	-14.89
4	<b>0.27109</b>	<b>0.09</b>	<b>46.32</b>	<b>44.40</b>	<b>46.41</b>	<b>44.49</b>	<b>61.08</b>	<b>51.08</b>	<b>-14.68</b>	<b>-6.60</b>
5	0.32969	0.09	43.61	39.24	43.70	39.33	59.46	49.46	-15.76	-10.13
6	10.21484	0.47	25.27	21.45	25.74	21.92	60.00	50.00	-34.26	-28.08

**REMARKS:**

1. Q.P. and AV. are abbreviations of quasi-peak and average individually.
2. The emission levels of other frequencies were very low against the limit.
3. Margin value = Emission level - Limit value
4. Correction factor = Insertion loss + Cable loss
5. Emission Level = Correction Factor + Reading Value.

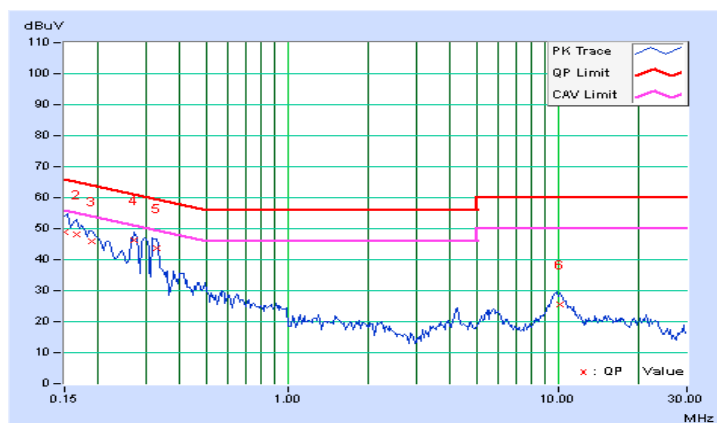

4.2.8 Test Results (Mode 2)

Phase	Line (L)	Detector Function	Quasi-Peak (QP) / Average (AV)
-------	----------	-------------------	--------------------------------

No	Freq. [MHz]	Corr.	Reading Value		Emission Level		Limit		Margin	
		Factor	[dB (uV)]		[dB (uV)]		[dB (uV)]		(dB)	
	(dB)	Q.P.	AV.	Q.P.	AV.	Q.P.	AV.	Q.P.	AV.	
1	0.15000	0.08	54.69	35.72	54.77	35.80	66.00	56.00	-11.23	-20.20
2	0.18125	0.09	48.38	35.53	48.47	35.62	64.43	54.43	-15.96	-18.81
3	0.23203	0.09	41.94	33.04	42.03	33.13	62.38	52.38	-20.35	-19.25
4	0.28672	0.09	38.66	27.09	38.75	27.18	60.62	50.62	-21.86	-23.43
5	0.38047	0.10	33.98	23.47	34.08	23.57	58.27	48.27	-24.19	-24.70
6	13.90234	0.55	30.25	25.48	30.80	26.03	60.00	50.00	-29.20	-23.97

REMARKS:

1. Q.P. and AV. are abbreviations of quasi-peak and average individually.
2. The emission levels of other frequencies were very low against the limit.
3. Margin value = Emission level - Limit value
4. Correction factor = Insertion loss + Cable loss
5. Emission Level = Correction Factor + Reading Value.

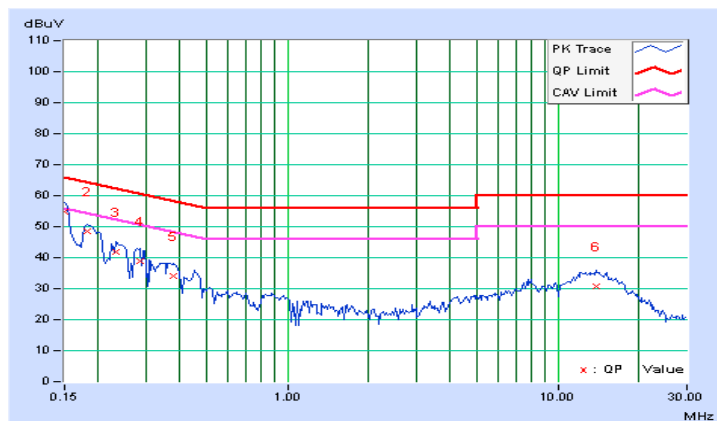

Phase	Neutral (N)	Detector Function	Quasi-Peak (QP) / Average (AV)
-------	-------------	-------------------	--------------------------------

No	Freq. [MHz]	Corr.	Reading Value		Emission Level		Limit		Margin	
		Factor	[dB (uV)]		[dB (uV)]		[dB (uV)]		(dB)	
		(dB)	Q.P.	AV.	Q.P.	AV.	Q.P.	AV.	Q.P.	AV.
1	0.15000	0.08	54.39	36.64	54.47	36.72	66.00	56.00	-11.53	-19.28
2	0.18125	0.08	48.28	36.29	48.36	36.37	64.43	54.43	-16.07	-18.06
3	0.23594	0.08	41.21	30.62	41.29	30.70	62.24	52.24	-20.94	-21.53
4	0.27891	0.09	37.70	28.15	37.79	28.24	60.85	50.85	-23.06	-22.61
5	0.35313	0.10	31.02	11.61	31.12	11.71	58.89	48.89	-27.77	-37.18
6	12.33203	0.53	29.00	24.36	29.53	24.89	60.00	50.00	-30.47	-25.11

**REMARKS:**

1. Q.P. and AV. are abbreviations of quasi-peak and average individually.
2. The emission levels of other frequencies were very low against the limit.
3. Margin value = Emission level - Limit value
4. Correction factor = Insertion loss + Cable loss
5. Emission Level = Correction Factor + Reading Value.

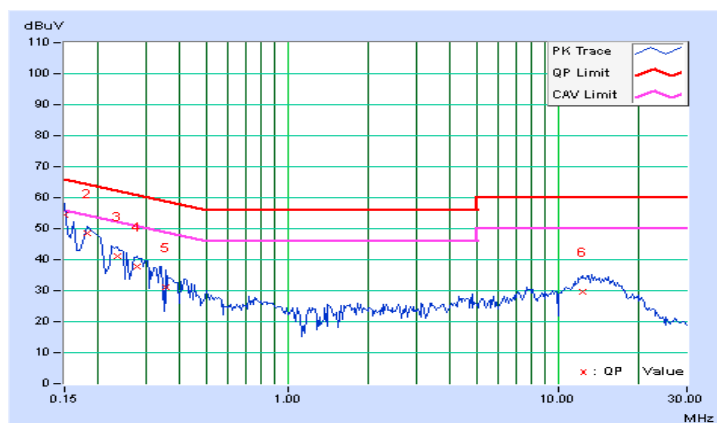

### 4.3 Transmit Power Measurement

#### 4.3.1 Limits of Transmit Power Measurement

Operation Band	EUT Category		LIMIT
U-NII-1		Outdoor Access Point	1 Watt (30 dBm) (Max. e.i.r.p $\leq$ 125mW(21 dBm) at any elevation angle above 30 degrees as measured from the horizon)
		Fixed point-to-point Access Point	1 Watt (30 dBm)
	√	Indoor Access Point	1 Watt (30 dBm)
		Mobile and Portable client device	250mW (24 dBm)
U-NII-2A	---		250mW (24 dBm) or 11 dBm+10 log B*
U-NII-2C	---		250mW (24 dBm) or 11 dBm+10 log B*
U-NII-3	√		1 Watt (30 dBm)

\*B is the 26 dB emission bandwidth in megahertz

Per KDB 662911 Method of conducted output power measurement on IEEE 802.11 devices,

Array Gain = 0 dB (i.e., no array gain) for  $N_{ANT} \leq 4$ ;

Array Gain = 0 dB (i.e., no array gain) for channel widths  $\geq 40$  MHz for any  $N_{ANT}$ ;

Array Gain =  $5 \log(N_{ANT}/N_{SS})$  dB or 3 dB, whichever is less for 20-MHz channel widths with  $N_{ANT} \geq 5$ .

For power measurements on all other devices: Array Gain =  $10 \log(N_{ANT}/N_{SS})$  dB.

#### 4.3.2 Test Setup

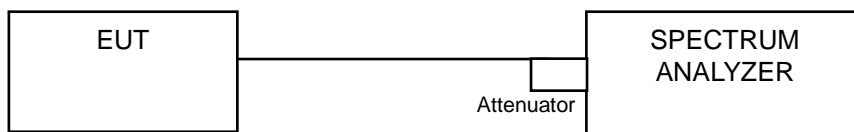

#### 4.3.3 Test Instruments

Refer to section 4.1.2 to get information of above instrument.

#### 4.3.4 Test Procedure

Method PM is used to perform output power measurement, trigger and gating function of wide band power meter is enabled to measure max output power of TX on burst. Duty factor is not added to measured value.

#### 4.3.5 Deviation from Test Standard

No deviation.

#### 4.3.6 EUT Operating Condition

The software provided by client to enable the EUT under transmission condition continuously at lowest, middle and highest channel frequencies individually.

**4.3.7 Test Result**
**1TX MODE**

Chan.	Chan. Freq. (MHz)	Average Power (dBm)	Power (mW)	Limit (dBm)	Pass / Fail
<b>802.11a</b>					
36	5180	14.98	31.477	30	Pass
40	5200	20.01	100.231	30	Pass
48	5240	22.11	162.555	30	Pass
149	5745	13.75	23.714	30	Pass
157	5785	19.10	81.283	30	Pass
165	5825	16.53	44.978	30	Pass
<b>802.11n (HT20)</b>					
36	5180	14.77	29.992	30	Pass
40	5200	20.14	103.276	30	Pass
48	5240	22.17	164.816	30	Pass
149	5745	13.07	20.277	30	Pass
157	5785	18.69	73.961	30	Pass
165	5825	16.76	47.424	30	Pass
<b>802.11n (HT40)</b>					
38	5190	10.61	11.508	30	Pass
46	5230	18.29	67.453	30	Pass
151	5755	10.82	12.078	30	Pass
159	5795	17.68	58.614	30	Pass

**2TX MODE**

Chan.	Freq. (MHz)	Maximum Conducted Power (dBm)		Total Power (mW)	Total Power (dBm)	Power Limit (dBm)	Pass / Fail
		Chain 0	Chain 1				
<b>802.11n (HT20)</b>							
36	5180	13.35	13.68	44.962	16.53	30	Pass
40	5200	19.77	19.86	191.67	22.83	30	Pass
48	5240	22.09	22.31	332.024	25.21	30	Pass
149	5745	12.86	12.93	38.954	15.91	30	Pass
157	5785	18.45	18.39	139.008	21.43	30	Pass
165	5825	16.36	16.18	84.746	19.28	30	Pass
<b>802.11n (HT40)</b>							
38	5190	10.22	10.19	20.967	13.22	30	Pass
46	5230	17.68	17.71	117.634	20.71	30	Pass
151	5755	10.43	10.80	23.064	13.63	30	Pass
159	5795	17.10	17.24	104.252	20.18	30	Pass

#### 4.4 Peak Power Spectral Density Measurement

##### 4.4.1 Limits of Peak Power Spectral Density Measurement

Operation Band	EUT Category		LIMIT
U-NII-1		Outdoor Access Point	17dBm/ MHz
		Fixed point-to-point Access Point	
	√	Indoor Access Point	
		Mobile and Portable client device	11dBm/ MHz
U-NII-2A	---		11dBm/ MHz
U-NII-2C	---		11dBm/ MHz
U-NII-3	√		30dBm/ 500kHz

##### 4.4.2 Test Setup

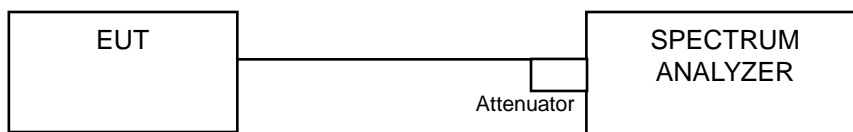

##### 4.4.3 Test Instruments

Refer to section 4.1.2 to get information of above instrument.

##### 4.4.4 Test Procedure

###### For U-NII-1 band:

Using method SA-1

1. Set span to encompass the entire emission bandwidth (EBW) of the signal.
2. Set RBW = 1 MHz, Set VBW ≥ 3 MHz, Detector = RMS
3. Sweep time = auto, trigger set to “free run”.
4. Trace average at least 100 traces in power averaging mode.
5. Record the max value

###### For U-NII-3 band:

1. Set span to encompass the entire emission bandwidth (EBW) of the signal.
2. Set RBW = 300 kHz, Set VBW ≥ 1 MHz, Detector = RMS
3. Use the peak marker function to determine the maximum power level in any 300 kHz band segment within the fundamental EBW.
4. Scale the observed power level to an equivalent value in 500 kHz by adjusting (reducing) the measured power by a bandwidth correction factor (BWCF) where  $BWCF = 10\log(500\text{ kHz}/300\text{kHz})$
5. Sweep time = auto, trigger set to “free run”.
6. Trace average at least 100 traces in power averaging mode.
7. Record the max value and for duty cycle of test signal is < 98% add  $10\log(1/\text{duty cycle})$



#### 4.4.5 Deviation from Test Standard

No deviation.

#### 4.4.6 EUT Operating Condition

Same as Item 4.3.6.

4.4.7 Test Results  
**For U-NII-1 Band**  
**1TX MODE**

Chan.	Chan. Freq. (MHz)	PSD (dBm)	MAX. Limit (dBm)	Pass / Fail
<b>802.11a</b>				
36	5180	1.29	17	Pass
40	5200	6.38	17	Pass
48	5240	8.44	17	Pass
<b>802.11n (HT20)</b>				
36	5180	1.19	17	Pass
40	5200	6.77	17	Pass
48	5240	8.47	17	Pass
<b>802.11n (HT40)</b>				
38	5190	-6.42	17	Pass
46	5230	1.60	17	Pass

**SPECTRUM PLOT OF WORST VALUE**

**802.11a – CH 48**

**802.11n (HT20) – CH 48**

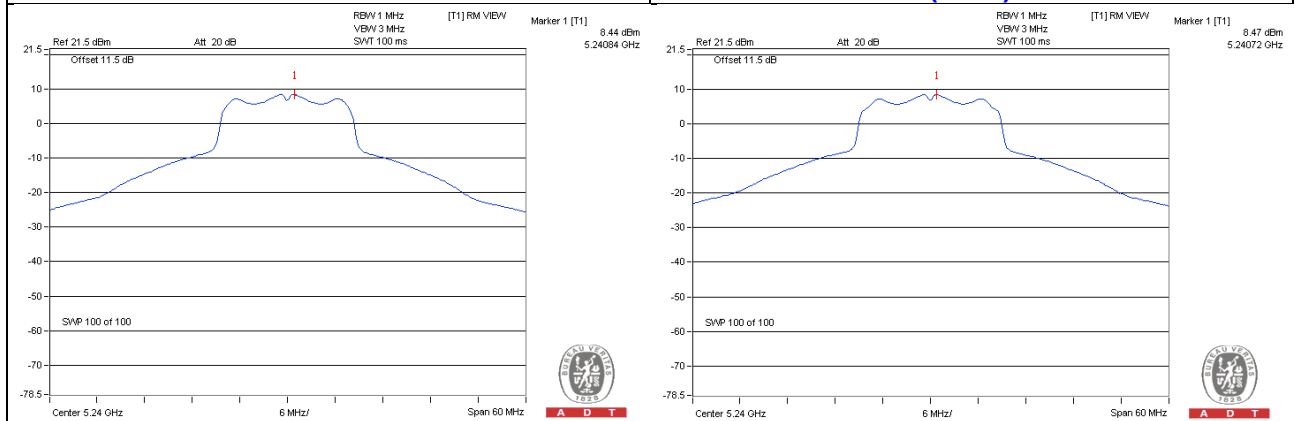

**802.11n (HT40) – CH 46**

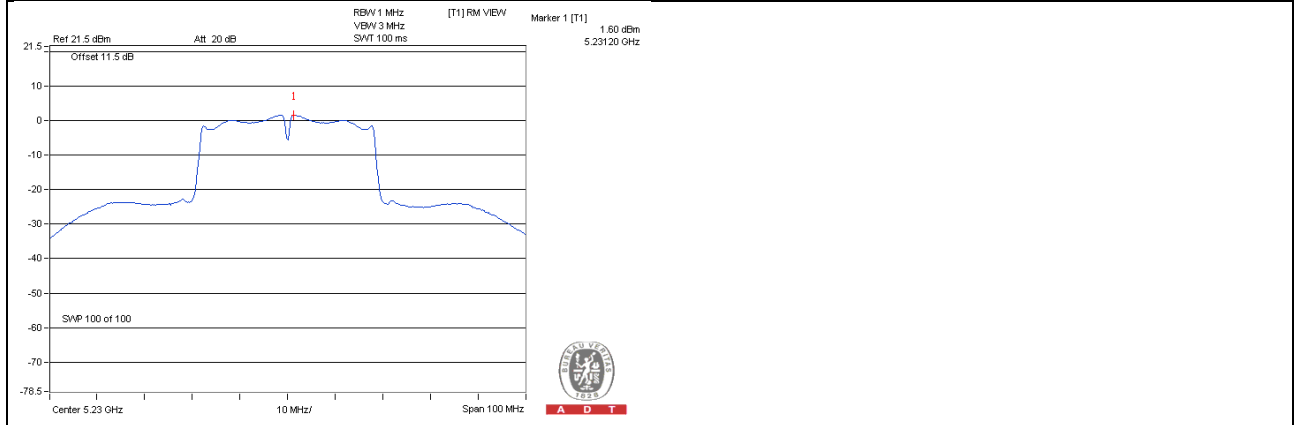

**2TX MODE**

Chan.	Chan. Freq. (MHz)	PSD (dBm)		Total Power Density (dBm)	Max. Limit (dBm)	Pass / Fail
		Chain 0	Chain 1			
<b>802.11n (HT20)</b>						
36	5180	-0.45	-0.54	2.52	17	Pass
40	5200	5.74	5.87	8.82	17	Pass
48	5240	3.65	7.12	8.73	17	Pass
<b>802.11n (HT40)</b>						
38	5190	-6.71	0.40	1.17	17	Pass
46	5230	0.74	0.84	3.80	17	Pass

**NOTE:** Method 1 of power density measurement of KDB 662911 is using for calculating total power density. Total power density is summing entire spectra across corresponding frequency bins on the various outputs by computer.

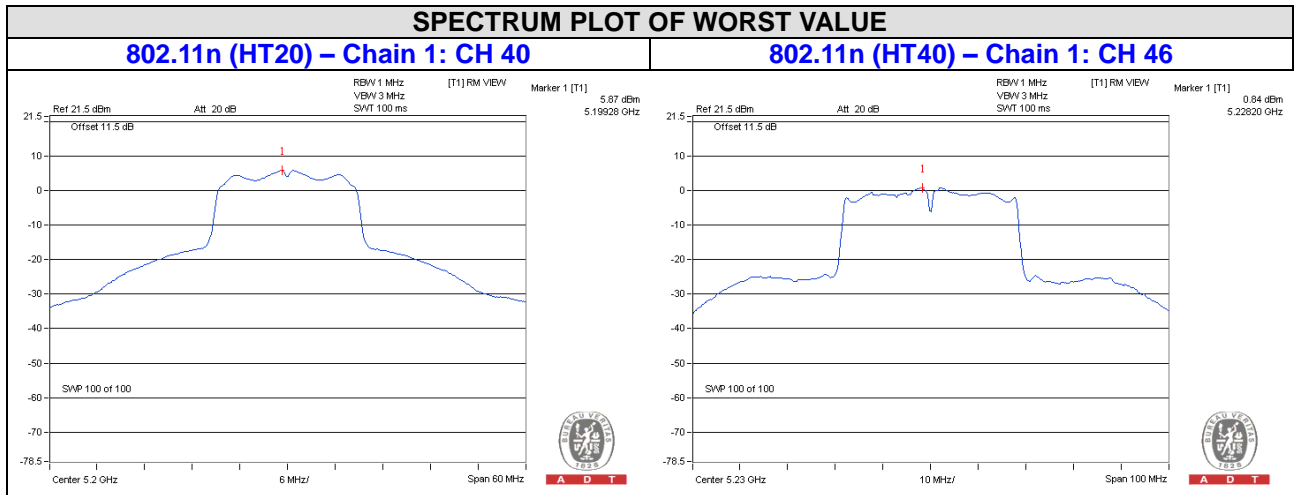

**For U-NII-3 Band  
1TX MODE**

Chan.	Chan. Freq. (MHz)	PSD		Limit (dBm/500kHz)	Pass /Fail
		(dBm/300kHz)	(dBm/500kHz)		
<b>802.11a</b>					
149	5745	-6.32	-4.10	30	Pass
157	5785	-1.26	0.96	30	Pass
165	5825	-3.48	-1.26	30	Pass
<b>802.11n (HT20)</b>					
149	5745	-6.99	-4.77	30	Pass
157	5785	-2.09	0.13	30	Pass
165	5825	-4.00	-1.78	30	Pass
<b>802.11n (HT40)</b>					
151	5755	-13.51	-11.29	30	Pass
159	5795	-6.32	-4.10	30	Pass

**SPECTRUM PLOT OF WORST VALUE**

**802.11a – CH 157**

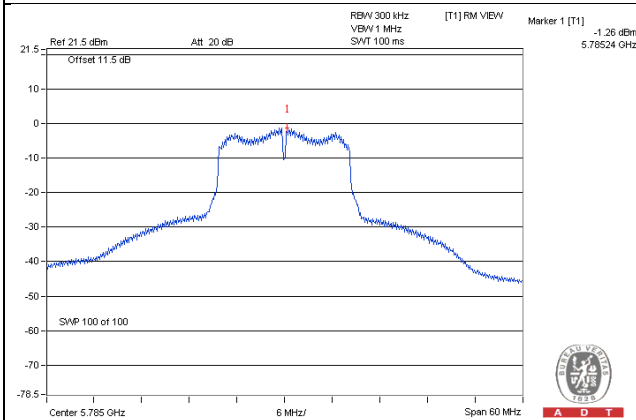

**802.11n (HT20) – CH 157**

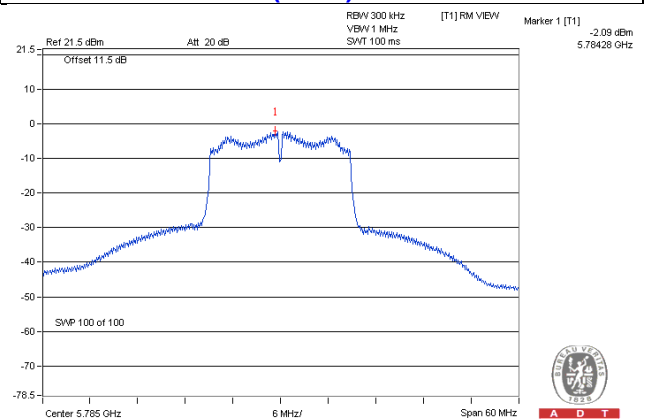

**802.11n (HT40) – CH 159**

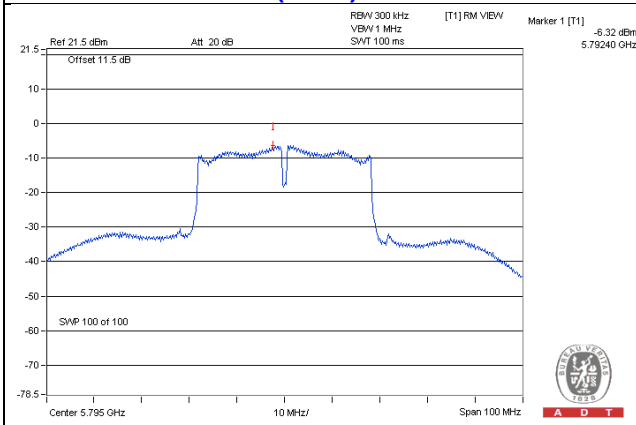

**2TX MODE**

TX chain	Chan.	Chan. Freq. (MHz)	PSD		10 log (N=2) dB	Total PSD (dBm/500kHz)	Limit (dBm/500kHz)	Pass /Fail
			(dBm/300kHz)	(dBm/500kHz)				
<b>802.11n (HT20)</b>								
0	149	5745	-6.99	-4.77	3.01	-1.76	30	Pass
	157	5785	-2.09	0.13	3.01	3.14	30	Pass
	165	5825	-4.00	-1.78	3.01	1.23	30	Pass
1	149	5745	-7.03	-4.81	3.01	-1.80	30	Pass
	157	5785	-2.12	0.10	3.01	3.11	30	Pass
	165	5825	-3.68	-1.46	3.01	1.55	30	Pass
<b>802.11n (HT40)</b>								
0	151	5755	-13.51	-11.29	3.01	-8.28	30	Pass
	159	5795	-6.32	-4.10	3.01	-1.09	30	Pass
1	151	5755	-13.81	-11.59	3.01	-8.58	30	Pass
	159	5795	-6.41	-4.19	3.01	-1.18	30	Pass

**SPECTRUM PLOT OF WORST VALUE**

**802.11n (HT20) – Chain 0: CH 157**

**802.11n (HT40) – Chain 0: CH 159**

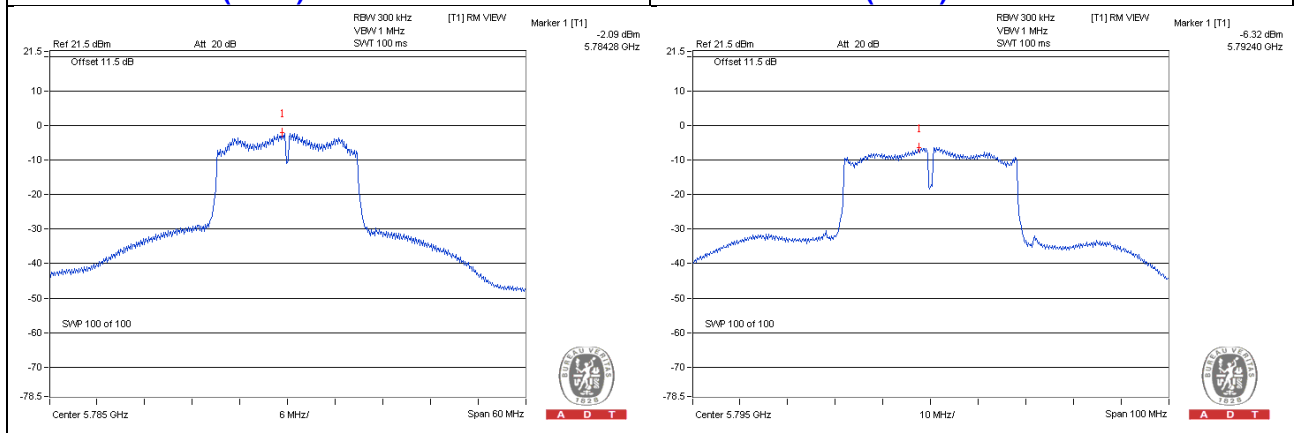

## 4.5 Frequency Stability Measurement

### 4.5.1 Limits of Frequency Stability Measurement

The frequency of the carrier signal shall be maintained within band of operation

### 4.5.2 Test Setup

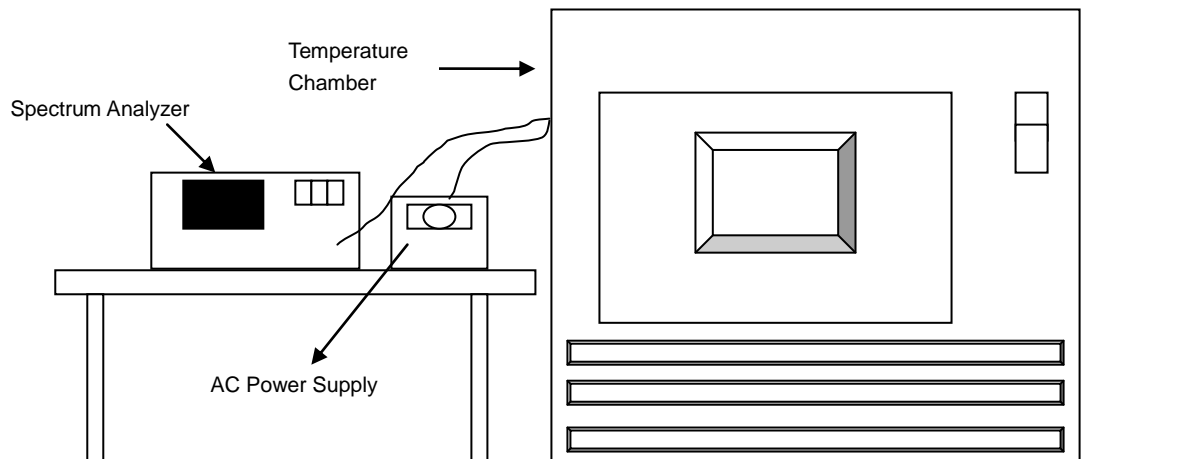

### 4.5.3 Test Instruments

Refer to section 4.1.2 to get information of above instrument.

### 4.5.4 Test Procedure

- a. The EUT was placed inside the environmental test chamber and powered by nominal AC voltage.
- b. Turn the EUT on and couple its output to a spectrum analyzer.
- c. Turn the EUT off and set the chamber to the highest temperature specified.
- d. Allow sufficient time (approximately 30 min) for the temperature of the chamber to stabilize, turn the EUT on and measure the operating frequency after 2, 5, and 10 minutes.
- e. Repeat step 2 and 3 with the temperature chamber set to the lowest temperature.
- f. The test chamber was allowed to stabilize at +20 degree C for a minimum of 30 minutes. The supply voltage was then adjusted on the EUT from 85% to 115% and the frequency record.

### 4.5.5 Deviation from Test Standard

No deviation.

### 4.5.6 EUT Operating Condition

Set the EUT transmit at un-modulation mode to test frequency stability.

**4.5.7 Test Results**

Frequency Stability Versus Temp.									
Operating Frequency: 5825MHz									
Temp. (°C)	Power Supply (Vac)	0 Minute		2 Minute		5 Minute		10 Minute	
		Measured Frequency (MHz)	Frequency Drift (%)	Measured Frequency (MHz)	Frequency Drift (%)	Measured Frequency (MHz)	Frequency Drift (%)	Measured Frequency (MHz)	Frequency Drift (%)
50	120	5824.9888	-0.00019	5824.9873	-0.00022	5824.9881	-0.00020	5824.9903	-0.00017
40	120	5825.0073	0.00013	5825.0089	0.00015	5825.0073	0.00013	5825.0094	0.00016
30	120	5824.9769	-0.00040	5824.9746	-0.00044	5824.9754	-0.00042	5824.9764	-0.00041
20	120	5825.0206	0.00035	5825.0178	0.00031	5825.02	0.00034	5825.0181	0.00031
10	120	5825.0049	0.00008	5825.0078	0.00013	5825.004	0.00007	5825.0058	0.00010
0	120	5825.0059	0.00010	5825.0054	0.00009	5825.0054	0.00009	5825.0048	0.00008
-10	120	5824.9976	-0.00004	5824.9976	-0.00004	5824.9988	-0.00002	5825.0003	0.00001
-20	120	5824.9736	-0.00045	5824.9726	-0.00047	5824.9713	-0.00049	5824.9694	-0.00053
-30	120	5824.982	-0.00031	5824.9835	-0.00028	5824.9837	-0.00028	5824.9803	-0.00034

Frequency Stability Versus Temp.									
Operating Frequency: 5825MHz									
Temp. (°C)	Power Supply (Vac)	0 Minute		2 Minute		5 Minute		10 Minute	
		Measured Frequency (MHz)	Frequency Drift (%)	Measured Frequency (MHz)	Frequency Drift (%)	Measured Frequency (MHz)	Frequency Drift (%)	Measured Frequency (MHz)	Frequency Drift (%)
20	138	5825.0209	0.00036	5825.0186	0.00032	5825.0207	0.00036	5825.0175	0.00030
	120	5825.0206	0.00035	5825.0178	0.00031	5825.02	0.00034	5825.0181	0.00031
	102	5825.0209	0.00036	5825.0178	0.00031	5825.0201	0.00035	5825.0172	0.00030

## 4.6 6dB Bandwidth Measurement

### 4.6.1 Limits of 6dB Bandwidth Measurement

The minimum of 6dB Bandwidth Measurement is 0.5MHz.

### 4.6.2 Test Setup

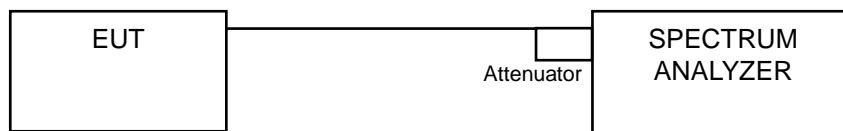

### 4.6.3 Test Instruments

Refer to section 4.1.2 to get information of above instrument.

### 4.6.4 Test Procedure

#### MEASUREMENT PROCEDURE REF

- Set resolution bandwidth (RBW) = 100kHz
- Set the video bandwidth (VBW)  $\geq 3 \times$  RBW, Detector = Peak.
- Trace mode = max hold.
- Sweep = auto couple.
- Measure the maximum width of the emission that is constrained by the frequencies associated with the two amplitude points (upper and lower) that are attenuated by 6 dB relative to the maximum level measured in the fundamental emission

### 4.6.5 Deviation from Test Standard

No deviation.

### 4.6.6 EUT Operating Condition

The software provided by client to enable the EUT under transmission condition continuously at lowest, middle and highest channel frequencies individually.



### 4.6.7 Test Results

#### 1TX MODE

Channel	Frequency (MHz)	6dB Bandwidth (MHz)	Minimum Limit (MHz)	Pass / Fail
<b>802.11a</b>				
149	5745	15.41	0.5	Pass
157	5785	15.16	0.5	Pass
165	5825	15.19	0.5	Pass
<b>802.11n (HT20)</b>				
149	5745	15.16	0.5	Pass
157	5785	15.17	0.5	Pass
165	5825	15.13	0.5	Pass
<b>802.11n (HT40)</b>				
151	5755	35.63	0.5	Pass
159	5795	35.78	0.5	Pass

### SPECTRUM PLOT OF WORST VALUE

**802.11a – CH 157**

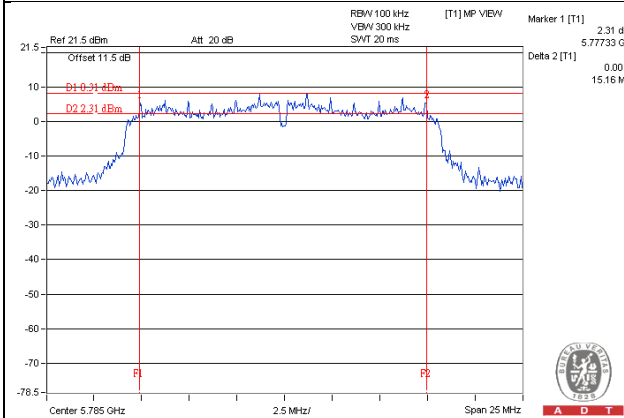

**802.11n (HT20) – CH 165**

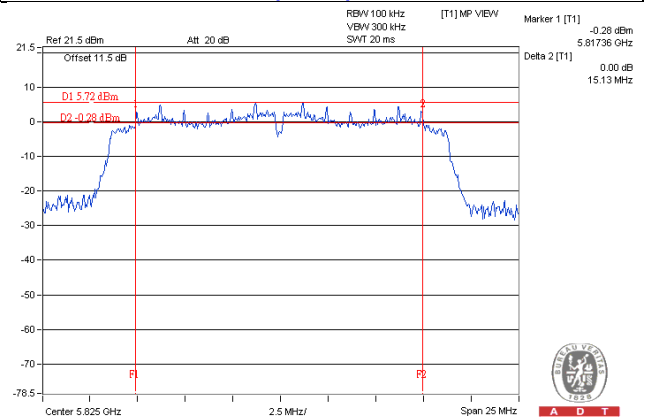

**802.11n (HT40) – CH 151**

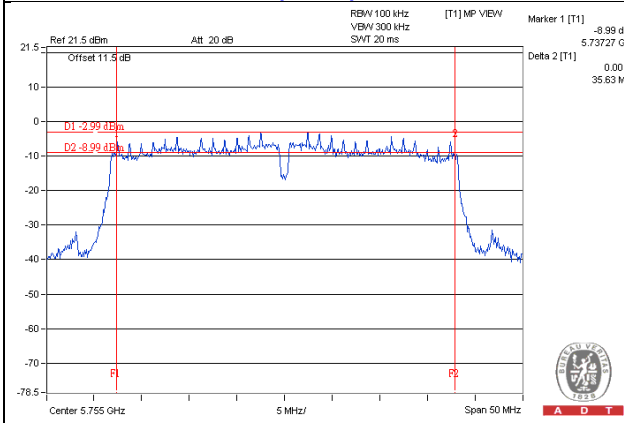

**2TX MODE**

Channel	Frequency (MHz)	6dB Bandwidth (MHz)		Minimum Limit (MHz)	Pass / Fail
		Chain 0	Chain 1		
<b>802.11n (HT20)</b>					
149	5745	15.16	16.32	0.5	Pass
157	5785	15.17	15.92	0.5	Pass
165	5825	15.13	15.53	0.5	Pass
<b>802.11n (HT40)</b>					
151	5755	35.63	36.36	0.5	Pass
159	5795	35.78	35.80	0.5	Pass

**SPECTRUM PLOT OF WORST VALUE**

**802.11n (HT20) – Chain 0: CH 165**

**802.11n (HT40) – Chain 0: CH 151**

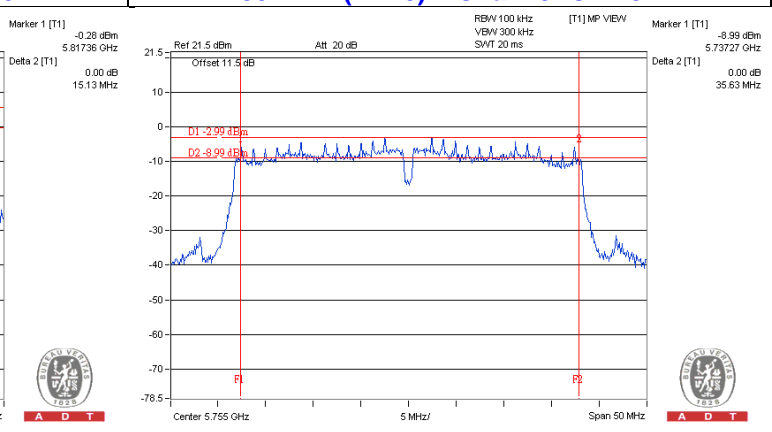
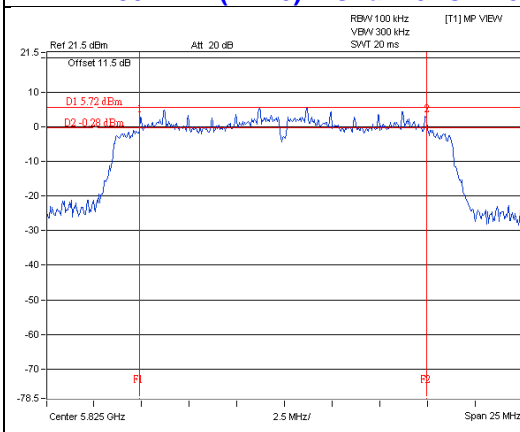

## 5 Pictures of Test Arrangements

Please refer to the attached file (Test Setup Photo).





## Appendix – Information on the Testing Laboratories

We, Bureau Veritas Consumer Products Services (H.K.) Ltd., Taoyuan Branch, were founded in 1988 to provide our best service in EMC, Radio, Telecom and Safety consultation. Our laboratories are accredited and approved according to ISO/IEC 17025.

If you have any comments, please feel free to contact us at the following:

**Linko EMC/RF Lab**

Tel: 886-2-26052180

Fax: 886-2-26051924

**Hsin Chu EMC/RF Lab/Telecom Lab**

Tel: 886-3-5935343

Fax: 886-3-5935342

**Hwa Ya EMC/RF/Safety**

Tel: 886-3-3183232

Fax: 886-3-3270892

**Email:** [service.adt@tw.bureauveritas.com](mailto:service.adt@tw.bureauveritas.com)

**Web Site:** [www.bureauveritas-adt.com](http://www.bureauveritas-adt.com)

The address and road map of all our labs can be found in our web site also.

--- END ---