

FCC Test Report

FCC ID : PY314300286
Equipment : Wireless AC750 DSL Modem Router
Model No. : D6000, D6010 (for marketing purpose only.)
Brand Name : NETGEAR
Applicant : NETGEAR, Inc.
Address : 350 East Plumeria Drive, San Jose, California
95134, USA
Standard : 47 CFR FCC Part 15.407
Received Date : Jun. 17, 2014
Tested Date : Jun. 19 ~ Jul. 30, 2014

We, International Certification Corp., would like to declare that the tested sample has been evaluated and in compliance with the requirement of the above standards. The test results contained in this report refer exclusively to the product. It may be duplicated completely for legal use with the approval of the applicant. It shall not be reproduced except in full without the written approval of our laboratory.

Approved & Reviewed by:

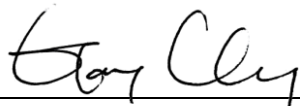

Gary Chang / Manager



Table of Contents

| | | |
|----------|--|-----------|
| 1 | GENERAL DESCRIPTION | 5 |
| 1.1 | Information..... | 5 |
| 1.2 | Local Support Equipment List | 8 |
| 1.3 | Test Setup Chart | 8 |
| 1.4 | The Equipment List | 9 |
| 1.5 | Testing Applied Standards | 10 |
| 1.6 | Measurement Uncertainty | 10 |
| 2 | TEST CONFIGURATION | 11 |
| 2.1 | Testing Condition | 11 |
| 2.2 | The Worst Test Modes and Channel Details | 11 |
| 3 | TRANSMITTER TEST RESULTS..... | 12 |
| 3.1 | Conducted Emissions..... | 12 |
| 3.2 | Emission Bandwidth | 15 |
| 3.3 | RF Output Power..... | 17 |
| 3.4 | Peak Power Spectral Density..... | 19 |
| 3.5 | Transmitter Radiated and Band Edge Emissions | 21 |
| 3.6 | Frequency Stability..... | 44 |
| 4 | TEST LABORATORY INFORMATION | 46 |

Release Record

| Report No. | Version | Description | Issued Date |
|------------|---------|---------------|---------------|
| FR432301AN | Rev. 01 | Initial issue | Aug. 21, 2014 |

Summary of Test Results

| FCC Rules | Test Items | Measured | Result |
|---------------------|-----------------------------|---|--------|
| 15.207 | Conducted Emissions | [dBuV]: 0.484MHz 41.42 (Margin -4.85dB) - AV | Pass |
| 15.407(b) 15.209 | Radiated Emissions | [dBuV/m at 3m]: 5150.00MHz 53.90 (Margin -0.10dB) - AV | Pass |
| 15.407(a) | Emission Bandwidth | Meet the requirement of limit | Pass |
| 15.407(a) | RF Output Power | Max Power [dBm]: 18.61 | Pass |
| 15.407(a) | Peak Power Spectral Density | Meet the requirement of limit | Pass |
| 15.407(g) | Frequency Stability | Meet the requirement of limit | Pass |
| 15.203 | Antenna Requirement | Meet the requirement of limit | Pass |

1 General Description

1.1 Information

1.1.1 Specification of the Equipment under Test (EUT)

| RF General Information | | | | | |
|------------------------|------------------|-----------------|----------------|------------------------------------|-----------------|
| Frequency Range (MHz) | IEEE Std. 802.11 | Ch. Freq. (MHz) | Channel Number | Transmit Chains (N _{TX}) | Data Rate / MCS |
| 5150-5250 | a | 5180-5240 | 36-48 [4] | 1 | 6-54 Mbps |
| 5150-5250 | n (HT20) | 5180-5240 | 36-48 [4] | 1 | MCS 0-7 |
| 5150-5250 | n (HT40) | 5190-5230 | 38-46 [2] | 1 | MCS 0-7 |
| 5150-5250 | ac (VHT20) | 5180-5240 | 36-48 [4] | 1 | MCS 0-8 |
| 5150-5250 | ac (VHT40) | 5190-5230 | 38-46 [2] | 1 | MCS 0-9 |
| 5150-5250 | ac (VHT80) | 5210 | 42 [1] | 1 | MCS 0-9 |

Note 1: RF output power specifies that Maximum Conducted Output Power.
 Note 2: 802.11a/n/ac uses a combination of OFDM-BPSK, QPSK, 16QAM, 64QAM, 256QAM modulation.

1.1.2 Antenna Details

| Ant. No. | Model | Type | Connector | Gain (dBi) |
|----------|--------------|--------|-----------|------------|
| 1 | 90VEAA15 G06 | dipole | I-PEX | 4.15 |

1.1.3 Power Supply Type of Equipment under Test (EUT)

| | |
|--------------------------|-----------------------|
| Power Supply Type | 12Vdc from AC adapter |
|--------------------------|-----------------------|

1.1.4 Accessories

| Accessories | | |
|-------------|--------------|--|
| No. | Equipment | Description |
| 1 | AC Adapter 1 | Brand Name: NETGEAR Model Name: ML18-7120150-A1 P/N: 332-10653-01 Power Rating: I/P: 120Vac, 60Hz, 0.5A O/P: 12Vdc, 1.5A Power Line: 1.85m non-shielded cable w/o core |
| 2 | AC Adapter 2 | Brand Name: NETGEAR Model Name: AD817F10 P/N: 332-10301-02 Power Rating: I/P: 100-120Vac, 50-60Hz, 0.56A O/P: 12Vdc, 1.5A Power Line: 1.85m non-shielded cable w/o core |

1.1.5 Channel List

| 802.11 a / HT20 / VHT20 | | HT40 / VHT40 | |
|-------------------------|----------------|--------------|----------------|
| Channel | Frequency(MHz) | Channel | Frequency(MHz) |
| 36 | 5180 | 38 | 5190 |
| 40 | 5200 | 46 | 5230 |
| 44 | 5220 | VHT80 | |
| 48 | 5240 | 42 | 5210 |

1.1.6 Test Tool and Duty Cycle

| Test Tool | MT76xx, Version 2.0.10.9 | | |
|----------------------------|--------------------------|----------------|------------------|
| Duty Cycle and Duty Factor | Mode | Duty cycle (%) | Duty factor (dB) |
| | 11a | 88.60% | 0.53 |
| | VHT20 | 88.43% | 0.53 |
| | VHT40 | 77.89% | 1.09 |
| | VHT80 | 61.98% | 2.08 |

1.1.7 Power Setting

| Modulation Mode | Test Frequency (MHz) | Power Set |
|-----------------|----------------------|-----------|
| 11a | 5180 | 15 |
| 11a | 5200 | 15 |
| 11a | 5240 | 14 |
| HT20 | 5180 | 16 |
| HT20 | 5200 | 15 |
| HT20 | 5240 | 14 |
| HT40 | 5190 | 12 |
| HT40 | 5230 | 16 |
| VHT20 | 5180 | 16 |
| VHT20 | 5200 | 15 |
| VHT20 | 5240 | 14 |
| VHT40 | 5190 | 12 |
| VHT40 | 5230 | 16 |
| VHT80 | 5210 | 0B |

1.2 Local Support Equipment List

| Support Equipment List | | | | | | |
|------------------------|-----------|-------|-------|-----|--------|---------------------------------|
| No. | Equipment | Brand | Model | S/N | FCC ID | Signal cable / Length (m) |
| 1 | Notebook | DELL | E6430 | --- | DoC | RJ45, 8m non-shielded w/o core. |

1.3 Test Setup Chart

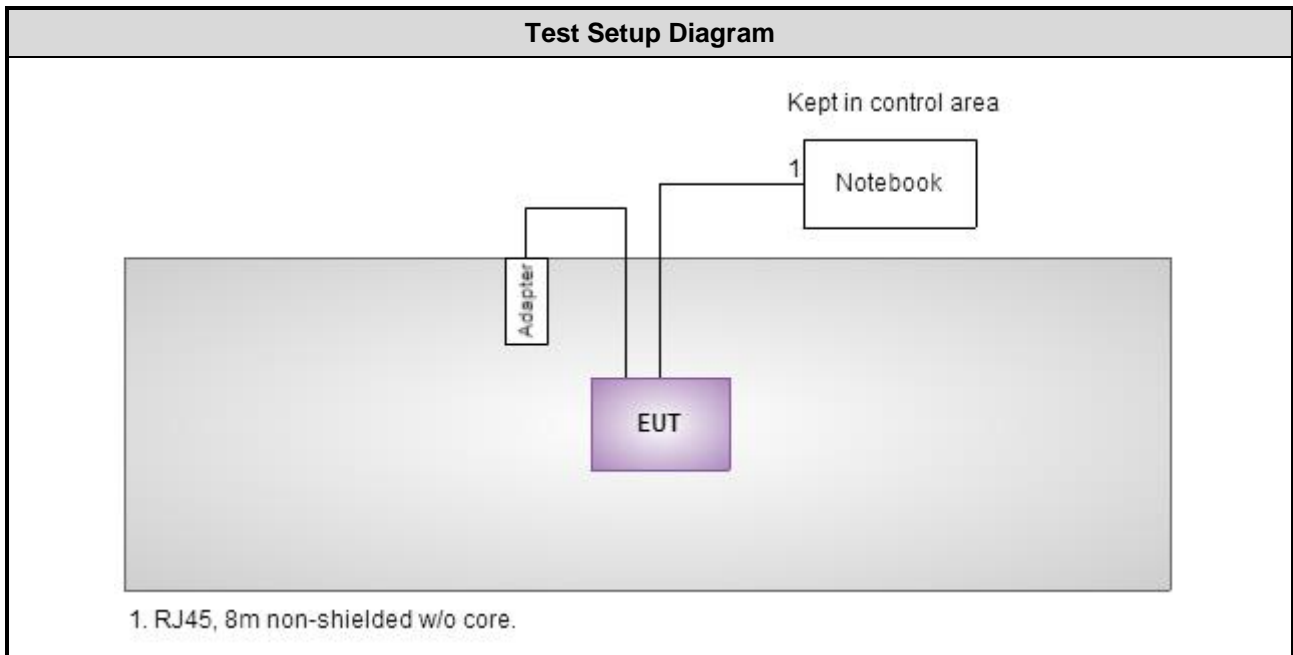

1.4 The Equipment List

| Test Item | Conducted Emission | | | | |
|-----------------------------------|-------------------------------|------------------|---------------|------------------|-------------------|
| Test Site | Conduction room 1 / (CO01-WS) | | | | |
| Instrument | Manufacturer | Model No. | Serial No. | Calibration Date | Calibration Until |
| EMC Receiver | R&S | ESCS 30 | 100169 | Oct. 15, 2013 | Oct. 14, 2014 |
| LISN | SCHWARZBECK | Schwarzbeck 8127 | 8127-667 | Nov. 23, 2013 | Nov. 22, 2014 |
| LISN (Support Unit) | SCHWARZBECK | Schwarzbeck 8127 | 8127-666 | Dec. 04, 2013 | Dec. 03, 2014 |
| RF Cable-CON | Woken | CFD200-NL | CFD200-NL-001 | Apr. 23, 2014 | Apr. 22, 2015 |
| 50 ohm terminal (Support Unit) | NA | 50 | 04 | Apr. 18, 2014 | Apr. 17, 2015 |

Note: Calibration Interval of instruments listed above is one year.

| Test Item | Radiated Emission | | | | |
|-------------------------|-----------------------------|-------------|------------------|------------------|-------------------|
| Test Site | 966 chamber 2 / (03CH02-WS) | | | | |
| Instrument | Manufacturer | Model No. | Serial No. | Calibration Date | Calibration Until |
| Spectrum Analyzer | R&S | FSV40 | 101499 | Feb. 08, 2014 | Feb. 07, 2015 |
| Receiver | R&S | ESR3 | 101657 | Jan. 18, 2014 | Jan. 17, 2015 |
| Bilog Antenna | SCHWARZBECK | VULB9168 | VULB9168-524 | Jan. 08, 2014 | Jan. 07, 2015 |
| Horn Antenna 1G-18G | SCHWARZBECK | BBHA 9120 D | BBHA 9120 D 1095 | Jan. 07, 2014 | Jan. 06, 2015 |
| Horn Antenna 18G-40G | SCHWARZBECK | BBHA 9170 | BBHA 9170517 | Dec. 27, 2013 | Dec. 26, 2014 |
| Preamplifier | Burgeon | BPA-530 | 100218 | Dec. 09, 2013 | Dec. 08, 2014 |
| Preamplifier | Agilent | 83017A | MY39501309 | Dec. 09, 2013 | Dec. 08, 2014 |
| Preamplifier | WM | TF-130N-R1 | 923365 | Oct. 23, 2013 | Oct. 22, 2014 |
| RF Cable | HUBER+SUHNER | SUCOFLEX104 | MY16140/4 | Dec. 17, 2013 | Dec. 16, 2014 |
| RF Cable | HUBER+SUHNER | SUCOFLEX104 | MY16018/4 | Dec. 17, 2013 | Dec. 16, 2014 |
| RF Cable | HUBER+SUHNER | SUCOFLEX104 | MY16015/4 | Dec. 17, 2013 | Dec. 16, 2014 |
| LF cable 3M | Woken | CFD400NL-LW | CFD400NL-003 | Dec. 17, 2013 | Dec. 16, 2014 |
| LF cable 10M | Woken | CFD400NL-LW | CFD400NL-004 | Dec. 17, 2013 | Dec. 16, 2014 |

Note: Calibration Interval of instruments listed above is one year.

| | | | | | |
|--------------|-----|---------|--------|---------------|---------------|
| Loop Antenna | R&S | HFH2-Z2 | 100330 | Nov. 15, 2012 | Nov. 14, 2014 |
|--------------|-----|---------|--------|---------------|---------------|

Note: Calibration Interval of instruments listed above is two year.

| Test Item | RF Conducted | | | | |
|--------------------------|--------------|------------------|-------------|------------------|-------------------|
| Test Site | (TH01-WS) | | | | |
| Instrument | Manufacturer | Model No. | Serial No. | Calibration Date | Calibration Until |
| Spectrum Analyzer | R&S | FSV40 | 101063 | Feb. 17, 2014 | Feb. 16, 2015 |
| TEMP&HUMIDITY CHAMBER | GIANT FORCE | GCT-225-40-SP-SD | MAF1212-002 | Dec. 11, 2013 | Dec. 10, 2014 |
| Power Meter | Anritsu | ML2495A | 1241002 | Oct. 24, 2013 | Oct. 23, 2014 |
| Power Sensor | Anritsu | MA2411B | 1207366 | Oct. 24, 2013 | Oct. 23, 2014 |

Note: Calibration Interval of instruments listed above is one year.

1.5 Testing Applied Standards

According to the specification of EUT, the EUT must comply with following standards and KDB documents.

47 CFR FCC Part 15.407

ANSI C63.10-2009

FCC KDB 412172

FCC 789033 D02 General UNII Test Procedures New Rules v01

FCC KDB 644545 D01 Guidance for IEEE 802 11ac v01r02

FCC KDB 644545 D02 Alternative Guidance for 802 11ac v01

Note: The EUT has been tested and complied with FCC part 15B requirement. FCC Part 15B test results are issued to another report.

1.6 Measurement Uncertainty

ISO/IEC 17025 requires that an estimate of the measurement uncertainties associated with the emissions test results be included in the report. The measurement uncertainties given below are based on a 95% confidence level (based on a coverage factor (k=2))

| Measurement Uncertainty | |
|--------------------------|-------------|
| Parameters | Uncertainty |
| Bandwidth | ±34.134 Hz |
| Conducted power | ±0.808 dB |
| Frequency error | ±34.134 Hz |
| Temperature | ±0.6 °C |
| Conducted emission | ±2.670 dB |
| AC conducted emission | ±2.92 dB |
| Radiated emission ≤ 1GHz | ±3.26 dB |
| Radiated emission > 1GHz | ±4.94 dB |

2 Test Configuration

2.1 Testing Condition

| Test Item | Test Site | Ambient Condition | Tested By |
|--------------------|-----------|-------------------|---------------------------|
| AC Conduction | CO01-WS | 21°C / 63% | Skys Huang |
| Radiated Emissions | 03CH02-WS | 25-26°C / 65% | Anderson Hong York Lin |
| RF Conducted | TH01-WS | 22°C / 64% | Felix Sung |

➤ FCC site registration No.: 657002

➤ IC site registration No.: 10807A-2

2.2 The Worst Test Modes and Channel Details

| Test item | Modulation Mode | Test Frequency (MHz) | Data Rate (Mbps) / MCS | Test Configuration |
|---|-----------------|----------------------|------------------------|--------------------|
| Conducted Emissions | VHT40 | 5230 | MCS 0 | 1 |
| Radiated Emissions ≤ 1 GHz | VHT40 | 5230 | MCS 0 | 2 |
| RF Output Power | 11a | 5180 / 5200 / 5240 | 6 Mbps | 2 |
| | HT20 | 5180 / 5200 / 5240 | MCS 0 | |
| | HT40 | 5190 / 5230 | MCS 0 | |
| | VHT20 | 5180 / 5200 / 5240 | MCS 0 | |
| | VHT40 | 5190 / 5230 | MCS 0 | |
| | VHT80 | 5210 | MCS 0 | |
| Radiated Emissions > 1 GHz Emission Bandwidth Peak Power Spectral Density | 11a | 5180 / 5200 / 5240 | 6 Mbps | 2 |
| | VHT20 | 5180 / 5200 / 5240 | MCS 0 | |
| | VHT40 | 5190 / 5230 | MCS 0 | |
| | VHT80 | 5210 | MCS 0 | |
| Frequency Stability | Un-modulation | 5240 | --- | --- |

NOTE:

- Adapter 1 & 2 had been covered during the pretest, and was selected as below configuration for final testing.
- Test configurations are listed as below:
 - Configuration 1: Adapter 1 (Model: ML18-7120150-A1)
 - Configuration 2: Adapter 2 (Model: AD817F10)

3 Transmitter Test Results

3.1 Conducted Emissions

3.1.1 Limit of Conducted Emissions

| Conducted Emissions Limit | | |
|---------------------------|------------|-----------|
| Frequency Emission (MHz) | Quasi-Peak | Average |
| 0.15-0.5 | 66 - 56 * | 56 - 46 * |
| 0.5-5 | 56 | 46 |
| 5-30 | 60 | 50 |

Note 1: * Decreases with the logarithm of the frequency.

3.1.2 Test Procedures

1. The device is placed on a test table, raised 80 cm above the reference ground plane. The vertical conducting plane is located 40 cm to the rear of the device.
2. The device is connected to line impedance stabilization network (LISN) and other accessories are connected to other LISN. Measured levels of AC power line conducted emission are across the 50 Ω LISN port.
3. AC conducted emission measurements is made over frequency range from 150 kHz to 30 MHz.
4. This measurement was performed with AC 120V / 60Hz.

3.1.3 Test Setup



Note: 1. Support units were connected to second LISN.

2. Both of LISNs (AMN) are 80 cm from EUT and at least 80 cm from other units and other metal planes

3.1.4 Test Result of Conducted Emissions

| | | | |
|-------------|-------|------------------|------|
| Modulation | VHT40 | Test Freq. (MHz) | 5230 |
| Power Phase | Line | | |

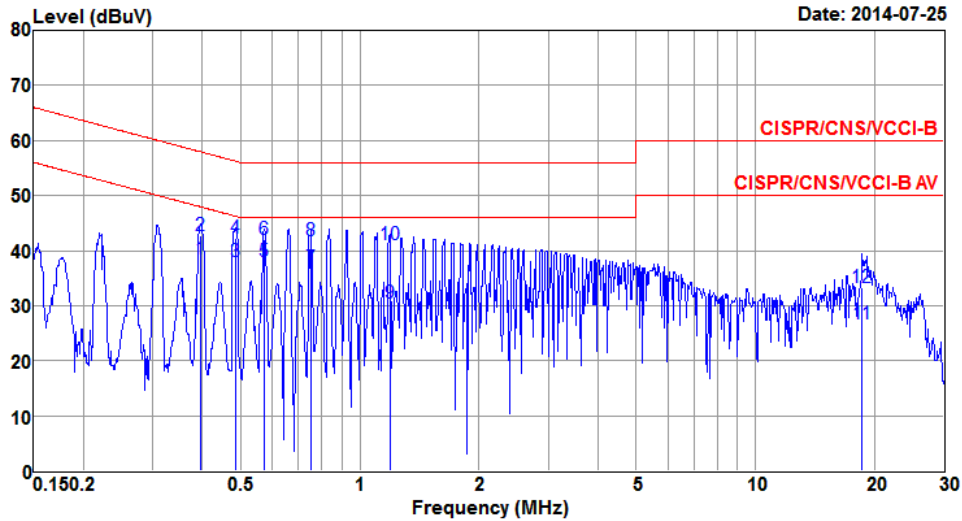

| | Freq MHz | Level dBuV | Limit Line dBuV | Over Limit dB | Read Level dBuV | LISN factor dB | cable loss dB | Remark |
|----|-------------|---------------|-----------------------|---------------------|-----------------------|----------------------|---------------------|---------|
| 1 | 0.396 | 38.56 | 47.95 | -9.39 | 38.01 | 0.53 | 0.02 | Average |
| 2 | 0.396 | 42.76 | 57.95 | -15.19 | 42.21 | 0.53 | 0.02 | QP |
| 3 | 0.484 | 37.95 | 46.27 | -8.32 | 37.32 | 0.57 | 0.06 | Average |
| 4 | 0.484 | 42.21 | 56.27 | -14.06 | 41.58 | 0.57 | 0.06 | QP |
| 5* | 0.573 | 37.93 | 46.00 | -8.07 | 37.23 | 0.61 | 0.09 | Average |
| 6 | 0.573 | 42.04 | 56.00 | -13.96 | 41.34 | 0.61 | 0.09 | QP |
| 7 | 0.751 | 36.88 | 46.00 | -9.12 | 36.07 | 0.67 | 0.14 | Average |
| 8 | 0.751 | 41.85 | 56.00 | -14.15 | 41.04 | 0.67 | 0.14 | QP |
| 9 | 1.197 | 30.51 | 46.00 | -15.49 | 29.56 | 0.80 | 0.15 | Average |
| 10 | 1.197 | 41.13 | 56.00 | -14.87 | 40.18 | 0.80 | 0.15 | QP |
| 11 | 18.622 | 26.70 | 50.00 | -23.30 | 24.27 | 2.05 | 0.38 | Average |
| 12 | 18.622 | 33.33 | 60.00 | -26.67 | 30.90 | 2.05 | 0.38 | QP |

Note 1: Level (dBuV) = Read Level (dBuV) + LISN Factor (dB) + Cable Loss (dB).
 2: Over Limit (dB) = Level (dBuV) – Limit Line (dBuV).

| | | | |
|--------------------|---------|-------------------------|------|
| Modulation | VHT40 | Test Freq. (MHz) | 5230 |
| Power Phase | Neutral | | |

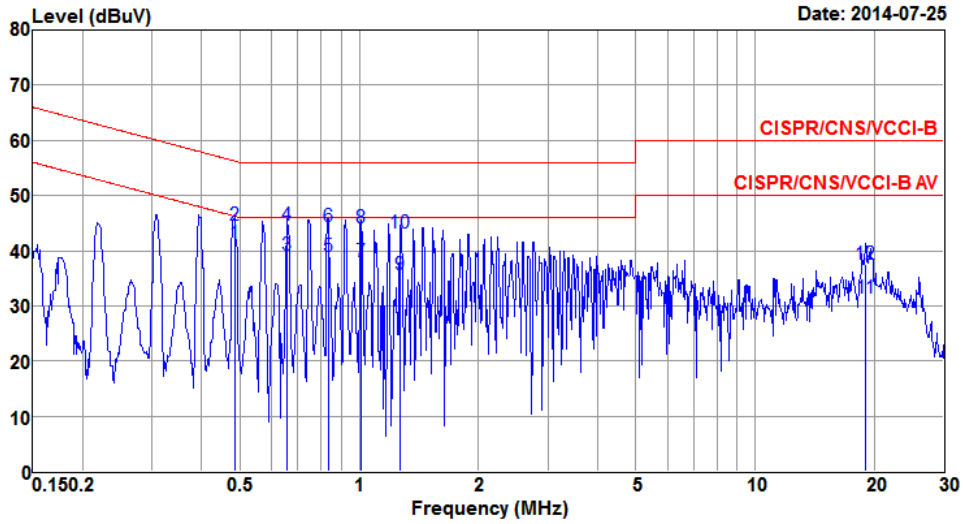

| | Freq MHz | Level dBuV | Limit Line dBuV | Over Limit dB | Read Level dBuV | LISN factor dB | cable loss dB | Remark |
|----|-------------|---------------|-----------------------|---------------------|-----------------------|----------------------|---------------------|---------|
| 1* | 0.484 | 41.42 | 46.27 | -4.85 | 40.71 | 0.65 | 0.06 | Average |
| 2 | 0.484 | 44.70 | 56.27 | -11.57 | 43.99 | 0.65 | 0.06 | QP |
| 3 | 0.658 | 39.12 | 46.00 | -6.88 | 38.29 | 0.71 | 0.12 | Average |
| 4 | 0.658 | 44.54 | 56.00 | -11.46 | 43.71 | 0.71 | 0.12 | QP |
| 5 | 0.835 | 39.06 | 46.00 | -6.94 | 38.14 | 0.76 | 0.16 | Average |
| 6 | 0.835 | 44.30 | 56.00 | -11.70 | 43.38 | 0.76 | 0.16 | QP |
| 7 | 1.010 | 37.89 | 46.00 | -8.11 | 36.89 | 0.80 | 0.20 | Average |
| 8 | 1.010 | 44.04 | 56.00 | -11.96 | 43.04 | 0.80 | 0.20 | QP |
| 9 | 1.273 | 35.56 | 46.00 | -10.44 | 34.52 | 0.90 | 0.14 | Average |
| 10 | 1.273 | 43.24 | 56.00 | -12.76 | 42.20 | 0.90 | 0.14 | QP |
| 11 | 19.021 | 31.28 | 50.00 | -18.72 | 28.36 | 2.54 | 0.38 | Average |
| 12 | 19.021 | 37.51 | 60.00 | -22.49 | 34.59 | 2.54 | 0.38 | QP |

Note 1: Level (dBuV) = Read Level (dBuV) + LISN Factor (dB) + Cable Loss (dB).
 2: Over Limit (dB) = Level (dBuV) – Limit Line (dBuV).

3.2 Emission Bandwidth

3.2.1 Test Procedures

26dB Bandwidth

1. Set RBW = approximately 1% of the emission bandwidth.
2. Set the VBW > RBW, Detector = Peak.
3. Trace mode = max hold.
4. Measure the maximum width of the emission that is 26 dB down from the peak of the emission.

Occupied Bandwidth

1. Set RBW = 1 % to 5 % of the OBW
2. Set VBW \geq 3 RBW
3. Sample detection and single sweep mode shall be used
4. Use the 99 % power bandwidth function of the instrument

3.2.2 Test Setup

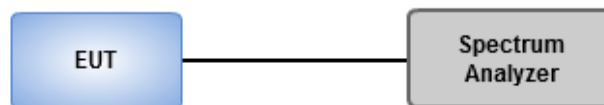

3.2.3 Test Result of Emission Bandwidth

| Emission Bandwidth | | | | | | | | | | |
|--------------------|-----------------|-------------|----------------------|---------|---------|---------|---------------------|---------|---------|---------|
| Mode | N _{TX} | Freq. (MHz) | 26dB Bandwidth (MHz) | | | | 99% Bandwidth (MHz) | | | |
| | | | Chain 0 | Chain 1 | Chain 0 | Chain 1 | Chain 0 | Chain 1 | Chain 0 | Chain 1 |
| 11a | 1 | 5180 | 27.88 | -- | -- | -- | 17.02 | -- | -- | -- |
| 11a | 1 | 5200 | 29.68 | -- | -- | -- | 17.13 | -- | -- | -- |
| 11a | 1 | 5240 | 29.10 | -- | -- | -- | 17.08 | -- | -- | -- |
| VHT20 | 1 | 5180 | 36.52 | -- | -- | -- | 18.67 | -- | -- | -- |
| VHT20 | 1 | 5200 | 29.74 | -- | -- | -- | 17.89 | -- | -- | -- |
| VHT20 | 1 | 5240 | 29.86 | -- | -- | -- | 17.89 | -- | -- | -- |
| VHT40 | 1 | 5190 | 53.57 | -- | -- | -- | 36.70 | -- | -- | -- |
| VHT40 | 1 | 5230 | 74.09 | -- | -- | -- | 37.40 | -- | -- | -- |
| VHT80 | 1 | 5210 | 94.61 | -- | -- | -- | 75.95 | -- | -- | -- |

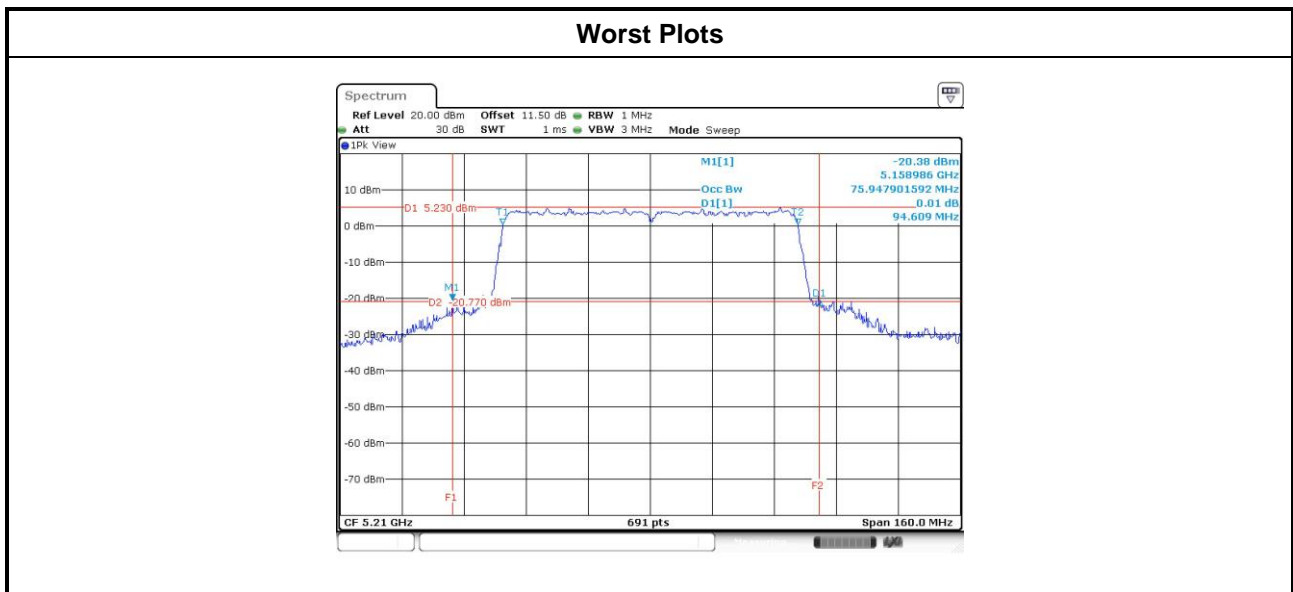

3.3 RF Output Power

3.3.1 Limit of RF Output Power

| Operating Mode | | Limit |
|-------------------------------------|------------------------------------|---|
| <input type="checkbox"/> | Outdoor access point | Conducted Power: 1 W The maximum e.i.r.p. at any elevation angle above 30 degrees as measured from the horizon must not exceed 125 mW (21 dBm) |
| <input checked="" type="checkbox"/> | Indoor access point | Conducted Power: 1 W |
| <input type="checkbox"/> | Fixed point-to-point access points | Conducted Power: 1 W |
| <input type="checkbox"/> | Mobile and portable client devices | Conducted Power: 250 mW |

3.3.2 Test Procedures

- Method PM-G (Measurement using a gated RF average power meter)**
 - Measurements may is performed using a wideband gated RF power meter provided that the gate parameters are adjusted such that the power is measured only when the EUT is transmitting at its maximum power control level. Since the measurement is made only during the ON time of the transmitter, no duty cycle correction factor is required.

3.3.3 Test Setup

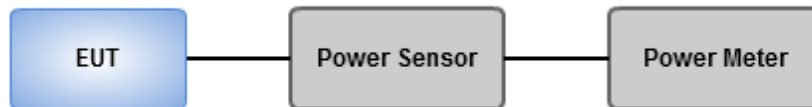

3.3.4 Test Result of Maximum Conducted Output Power

| Mode | N _{TX} | Freq. (MHz) | Conducted Power (dBm) | | | | Total Power (mW) | Total Power (dBm) | Limit (dBm) |
|-------|-----------------|-------------|-----------------------|---------|---------|---------|------------------|-------------------|-------------|
| | | | Chain 0 | Chain 1 | Chain 2 | Chain 3 | | | |
| 11a | 1 | 5180 | 18.34 | -- | -- | -- | 68.234 | 18.34 | 30.00 |
| 11a | 1 | 5200 | 18.41 | -- | -- | -- | 69.343 | 18.41 | 30.00 |
| 11a | 1 | 5240 | 18.02 | -- | -- | -- | 63.387 | 18.02 | 30.00 |
| HT20 | 1 | 5180 | 18.41 | -- | -- | -- | 69.343 | 18.41 | 30.00 |
| HT20 | 1 | 5200 | 18.06 | -- | -- | -- | 63.973 | 18.06 | 30.00 |
| HT20 | 1 | 5240 | 17.65 | -- | -- | -- | 58.210 | 17.65 | 30.00 |
| HT40 | 1 | 5190 | 16.72 | -- | -- | -- | 46.989 | 16.72 | 30.00 |
| HT40 | 1 | 5230 | 18.53 | -- | -- | -- | 71.285 | 18.53 | 30.00 |
| VHT20 | 1 | 5180 | 18.52 | -- | -- | -- | 71.121 | 18.52 | 30.00 |
| VHT20 | 1 | 5200 | 18.23 | -- | -- | -- | 66.527 | 18.23 | 30.00 |
| VHT20 | 1 | 5240 | 17.78 | -- | -- | -- | 59.979 | 17.78 | 30.00 |
| VHT40 | 1 | 5190 | 16.85 | -- | -- | -- | 48.417 | 16.85 | 30.00 |
| VHT40 | 1 | 5230 | 18.61 | -- | -- | -- | 72.611 | 18.61 | 30.00 |
| VHT80 | 1 | 5210 | 13.68 | -- | -- | -- | 23.335 | 13.68 | 30.00 |

3.4 Peak Power Spectral Density

3.4.1 Limit of Peak Power Spectral Density

| Operating Mode | | Limit |
|-------------------------------------|------------------------------------|--------------|
| <input type="checkbox"/> | Outdoor access point | 17 dBm / MHz |
| <input checked="" type="checkbox"/> | Indoor access point | 17 dBm / MHz |
| <input type="checkbox"/> | Fixed point-to-point access points | 17 dBm / MHz |
| <input type="checkbox"/> | Mobile and portable client devices | 11 dBm / MHz |

3.4.2 Test Procedures

Method SA-1

1. Set RBW = 1 MHz, VBW = 3 MHz, Sweep time = auto, Detector = RMS.
2. Trace average 100 traces.
3. Use the peak marker function to determine the maximum amplitude level.

Method SA-2 Alternative

1. Set RBW = 1 MHz, VBW = 3 MHz, Detector = RMS.
2. Set sweep time $\geq 10 * (\text{number of points in sweep}) * (\text{total on/off period of the transmitted signal})$.
3. Perform a single sweep.
4. Use the peak marker function to determine the maximum amplitude level.
5. Add $10 \log(1/x)$, where x is the duty cycle.

3.4.3 Test Setup

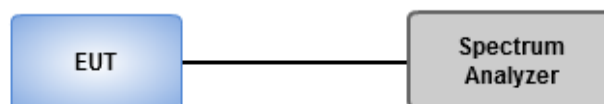

3.4.4 Test Result of Peak Power Spectral Density

| Condition | | | Peak Power Spectral Density (dBm) | | | |
|-----------|-----------------|-------------|-----------------------------------|------------------|---------------------|------------------|
| Mode | N _{TX} | Freq. (MHz) | PPSD w/o D.F (dBm) | Duty Factor (dB) | PPSD with D.F (dBm) | PPSD Limit (dBm) |
| 11a | 1 | 5180 | 5.46 | 0.53 | 5.99 | 17 |
| 11a | 1 | 5200 | 5.48 | 0.53 | 6.01 | 17 |
| 11a | 1 | 5240 | 5.06 | 0.53 | 5.59 | 17 |
| VHT20 | 1 | 5180 | 5.38 | 0.53 | 5.91 | 17 |
| VHT20 | 1 | 5200 | 5.05 | 0.53 | 5.58 | 17 |
| VHT20 | 1 | 5240 | 4.69 | 0.53 | 5.22 | 17 |
| VHT40 | 1 | 5190 | 0.07 | 1.09 | 1.16 | 17 |
| VHT40 | 1 | 5230 | 1.73 | 1.09 | 2.82 | 17 |
| VHT80 | 1 | 5210 | -7.01 | 2.08 | -4.93 | 17 |

Note: D.F is duty factor.

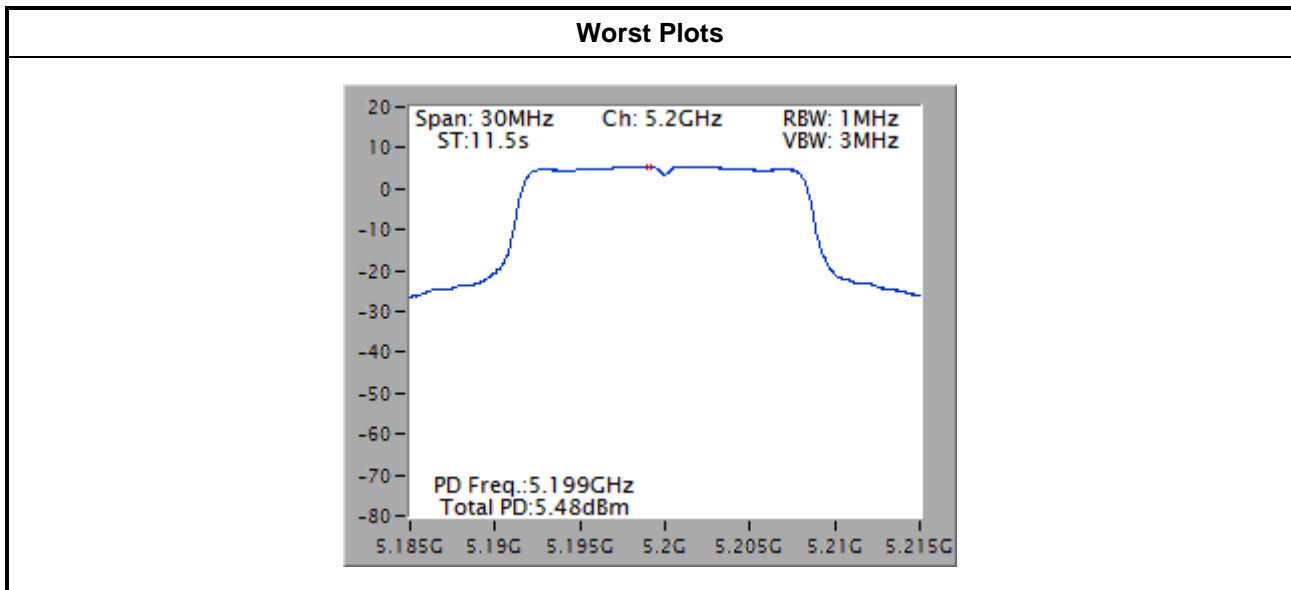

Note: Power density plot without duty factor

3.5 Transmitter Radiated and Band Edge Emissions

3.5.1 Limit of Transmitter Radiated and Band Edge Emissions

| Restricted Band Emissions Limit | | | |
|---------------------------------|-----------------------|-------------------------|----------------------|
| Frequency Range (MHz) | Field Strength (uV/m) | Field Strength (dBuV/m) | Measure Distance (m) |
| 0.009~0.490 | 2400/F(kHz) | 48.5 - 13.8 | 300 |
| 0.490~1.705 | 24000/F(kHz) | 33.8 - 23 | 30 |
| 1.705~30.0 | 30 | 29 | 30 |
| 30~88 | 100 | 40 | 3 |
| 88~216 | 150 | 43.5 | 3 |
| 216~960 | 200 | 46 | 3 |
| Above 960 | 500 | 54 | 3 |

Note 1:
Qusai-Peak value is measured for frequency below 1GHz except for 9–90 kHz, 110–490 kHz frequency band. Peak and average value are measured for frequency above 1GHz. The limit on average radio frequency emission is as above table. The limit on peak radio frequency emissions is 20 dB above the maximum permitted average emission limit

Note 2:
Measurements may be performed at a distance other than what is specified provided. When performing measurements at a distance other than that specified, the results shall be extrapolated to the specified distance using an extrapolation factor as below, Frequency at or above 30 MHz: 20 dB/decade Frequency below 30 MHz: 40 dB/decade.

| Un-restricted band emissions above 1GHz Limit | |
|---|---|
| Operating Band | Limit |
| 5.15 - 5.25 GHz | e.i.r.p. -27 dBm [68.2 dBuV/m@3m] |
| 5.25 - 5.35 GHz | e.i.r.p. -27 dBm [68.2 dBuV/m@3m] |
| 5.47 - 5.725 GHz | e.i.r.p. -27 dBm [68.2 dBuV/m@3m] |
| 5.725 - 5.825 GHz | 5.715 5.725 GHz: e.i.r.p. -17 dBm [78.2 dBuV/m@3m] 5.85 5.86 GHz: e.i.r.p. -17 dBm [78.2 dBuV/m@3m] Other un-restricted band: e.i.r.p. -27 dBm [68.2 dBuV/m@3m] |

Note 1: Measurements may be performed at a distance other than the limit distance provided they are not performed in the near field and the emissions to be measured can be detected by the measurement equipment. When performing measurements at a distance other than that specified, the results shall be extrapolated to the specified distance using an extrapolation factor of 20 dB/decade (inverse of linear distance for field-strength measurements, inverse of linear distance-squared for power-density measurements).

3.5.2 Test Procedures

1. Measurement is made at a semi-anechoic chamber that incorporates a turntable allowing a EUT rotation of 360°. A continuously-rotating, remotely-controlled turntable is installed at the test site to support the EUT and facilitate determination of the direction of maximum radiation for each EUT emission frequency. The EUT is placed at a height of 0.8 m test table above the ground plane.
2. Measurement is made with the antenna positioned in both the horizontal and vertical planes of polarization. The measurement antenna is varied in height (1m ~ 4m) above the reference ground plane to obtain the maximum signal strength. Distance between EUT and antenna is 3 m.
3. This investigation is performed with the EUT rotated 360°, the antenna height scanned between 1 m and 4 m, and the antenna rotated to repeat the measurements for both the horizontal and vertical antenna polarizations.

Note:

1. 120kHz measurement bandwidth of test receiver and Quasi-peak detector is for radiated emission below 1GHz.
2. RBW=1MHz, VBW=3MHz and Peak detector is for peak measured value of radiated emission above 1GHz.
3. RBW=1MHz, VBW=1/T and Peak detector is for average measured value of radiated emission above 1GHz.

3.5.3 Test Setup

Radiated Emissions below 1 GHz

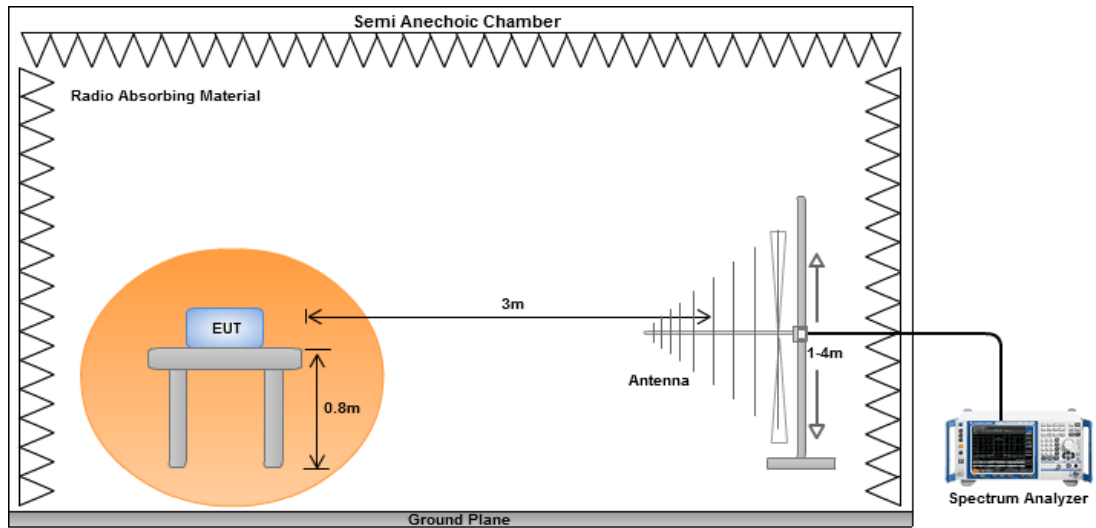

Radiated Emissions above 1 GHz

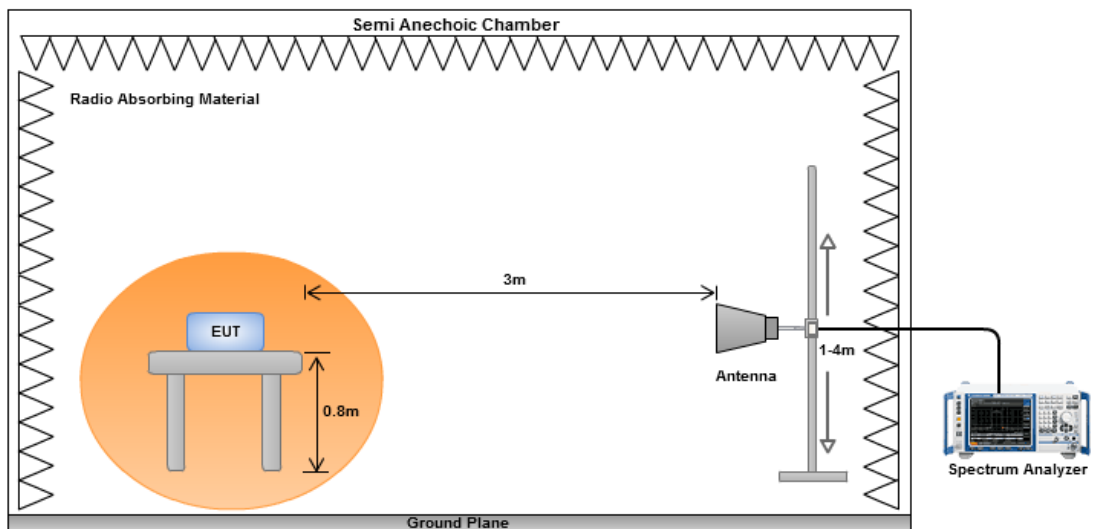

3.5.4 Transmitter Radiated Unwanted Emissions (Below 1GHz)

| | | | |
|--------------|------------|------------------|------|
| Modulation | VHT40 | Test Freq. (MHz) | 5230 |
| Polarization | Horizontal | | |

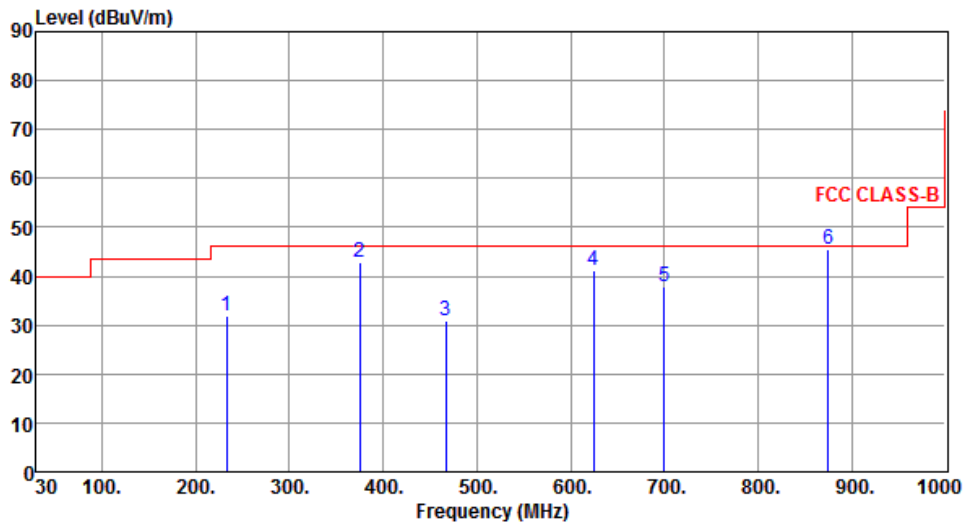

| | Freq. MHz | Emission level dBuV/m | Limit dBuV/m | Margin dB | SA reading dBuV | Factor dB | Remark | ANT High cm | Turn Table deg |
|---|--------------|-----------------------------|-----------------|--------------|-----------------------|--------------|--------|-------------------|----------------------|
| 1 | 232.73 | 31.82 | 46.00 | -14.18 | 50.41 | -18.59 | Peak | --- | --- |
| 2 | 375.45 | 42.88 | 46.00 | -3.12 | 57.29 | -14.41 | Peak | --- | --- |
| 3 | 466.50 | 30.77 | 46.00 | -15.23 | 43.01 | -12.24 | Peak | --- | --- |
| 4 | 624.64 | 41.26 | 46.00 | -4.74 | 50.57 | -9.31 | Peak | --- | --- |
| 5 | 700.27 | 37.86 | 46.00 | -8.14 | 46.18 | -8.32 | Peak | --- | --- |
| 6 | 874.75 | 45.48 | 46.00 | -0.52 | 51.39 | -5.91 | QP | --- | --- |

Note 1: Emission Level (dBuV/m) = SA Reading (dBuV/m) + Factor* (dB)

*Factor includes antenna factor, cable loss and amplifier gain

Note 2: Margin (dB) = Emission level (dBuV/m) – Limit (dBuV/m).

Note 3: All spurious emissions below 30MHz are more than 20 dB below the limit.

| | | | |
|---------------------|----------|-------------------------|------|
| Modulation | VHT40 | Test Freq. (MHz) | 5230 |
| Polarization | Vertical | | |

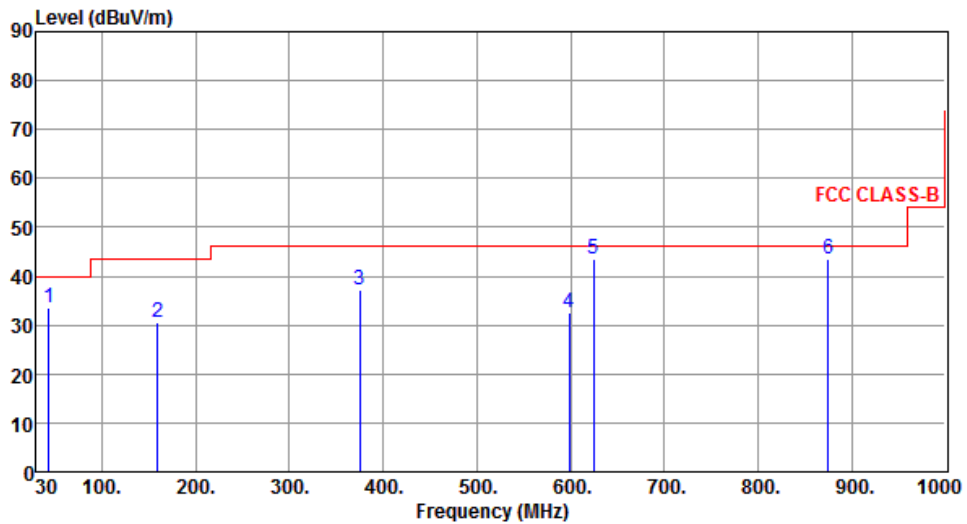

| | Freq. MHz | Emission level dBuV/m | Limit dBuV/m | Margin dB | SA reading dBuV | Factor dB | Remark | ANT High cm | Turn Table deg |
|---|--------------|-----------------------------|-----------------|--------------|-----------------------|--------------|--------|-------------------|----------------------|
| 1 | 43.21 | 33.64 | 40.00 | -6.36 | 50.47 | -16.83 | QP | --- | --- |
| 2 | 159.01 | 30.47 | 43.50 | -13.03 | 47.19 | -16.72 | Peak | --- | --- |
| 3 | 375.26 | 37.28 | 46.00 | -8.72 | 51.69 | -14.41 | Peak | --- | --- |
| 4 | 598.42 | 32.61 | 46.00 | -13.39 | 42.21 | -9.60 | Peak | --- | --- |
| 5 | 624.75 | 43.51 | 46.00 | -2.49 | 52.82 | -9.31 | QP | --- | --- |
| 6 | 874.87 | 43.43 | 46.00 | -2.57 | 49.34 | -5.91 | QP | --- | --- |

Note 1: Emission Level (dBuV/m) = SA Reading (dBuV/m) + Factor* (dB)

*Factor includes antenna factor , cable loss and amplifier gain

Note 2: Margin (dB) = Emission level (dBuV/m) – Limit (dBuV/m).

Note 3: All spurious emissions below 30MHz are more than 20 dB below the limit.

3.5.5 Transmitter Radiated Unwanted Emissions (Above 1GHz) for 11a

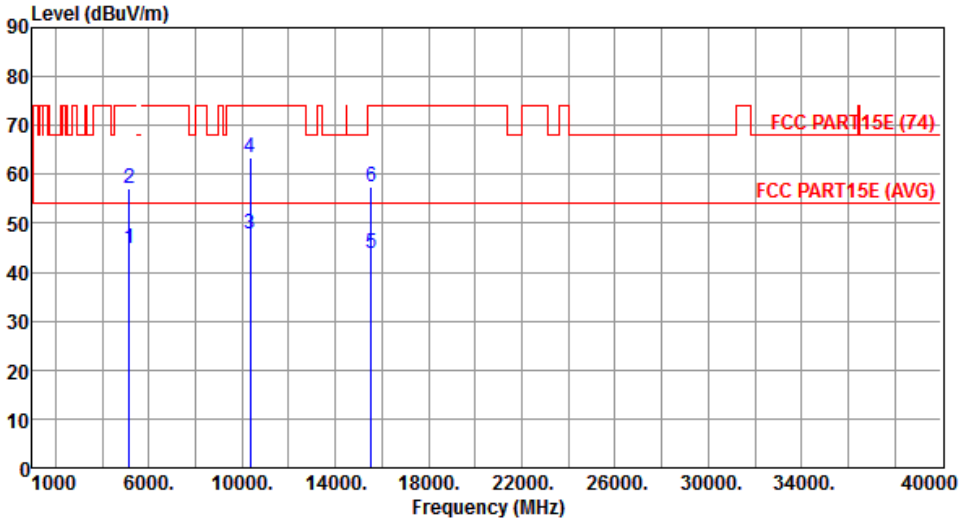
| Modulation | 11a | Test Freq. (MHz) | 5180 | | | | | | | | | | | | | | | | | | | | | | | | | | | | | | | | | | | | | | | | | | | | | | | | | | | | | | | | | | | | | | | | | | | | | | |
|---|--|------------------|----------------|------------|--------|------------|----------|------------|----------|------------|-----|--------|--------|----|------|----|--|----|-----|---|---------|-------|-------|-------|-------|------|---------|-----|---|---------|-------|-------|--------|-------|------|------|-----|---|----------|-------|-------|-------|-------|-------|---------|-----|---|----------|-------|-------|--------|-------|-------|------|-----|---|----------|-------|-------|--------|-------|-------|---------|-----|---|----------|-------|-------|--------|-------|-------|------|-----|
| Polarization | Horizontal | | | | | | | | | | | | | | | | | | | | | | | | | | | | | | | | | | | | | | | | | | | | | | | | | | | | | | | | | | | | | | | | | | | | | | | | |
|  | | | | | | | | | | | | | | | | | | | | | | | | | | | | | | | | | | | | | | | | | | | | | | | | | | | | | | | | | | | | | | | | | | | | | | | | | |
| | <table border="1"> <thead> <tr> <th>Freq.</th> <th>Emission level</th> <th>Limit</th> <th>Margin</th> <th>SA reading</th> <th>Factor</th> <th>Remark</th> <th>ANT High</th> <th>Turn Table</th> </tr> <tr> <th>MHz</th> <th>dBuV/m</th> <th>dBuV/m</th> <th>dB</th> <th>dBuV</th> <th>dB</th> <th></th> <th>cm</th> <th>deg</th> </tr> </thead> <tbody> <tr> <td>1</td> <td>5150.00</td> <td>44.89</td> <td>54.00</td> <td>-9.11</td> <td>39.18</td> <td>5.71</td> <td>Average</td> <td>---</td> </tr> <tr> <td>2</td> <td>5150.00</td> <td>57.05</td> <td>74.00</td> <td>-16.95</td> <td>51.34</td> <td>5.71</td> <td>Peak</td> <td>---</td> </tr> <tr> <td>3</td> <td>10360.00</td> <td>47.81</td> <td>54.00</td> <td>-6.19</td> <td>33.37</td> <td>14.44</td> <td>Average</td> <td>---</td> </tr> <tr> <td>4</td> <td>10360.00</td> <td>63.46</td> <td>74.00</td> <td>-10.54</td> <td>49.02</td> <td>14.44</td> <td>Peak</td> <td>---</td> </tr> <tr> <td>5</td> <td>15540.00</td> <td>43.82</td> <td>54.00</td> <td>-10.18</td> <td>28.53</td> <td>15.29</td> <td>Average</td> <td>---</td> </tr> <tr> <td>6</td> <td>15540.00</td> <td>57.37</td> <td>74.00</td> <td>-16.63</td> <td>42.08</td> <td>15.29</td> <td>Peak</td> <td>---</td> </tr> </tbody> </table> | Freq. | Emission level | Limit | Margin | SA reading | Factor | Remark | ANT High | Turn Table | MHz | dBuV/m | dBuV/m | dB | dBuV | dB | | cm | deg | 1 | 5150.00 | 44.89 | 54.00 | -9.11 | 39.18 | 5.71 | Average | --- | 2 | 5150.00 | 57.05 | 74.00 | -16.95 | 51.34 | 5.71 | Peak | --- | 3 | 10360.00 | 47.81 | 54.00 | -6.19 | 33.37 | 14.44 | Average | --- | 4 | 10360.00 | 63.46 | 74.00 | -10.54 | 49.02 | 14.44 | Peak | --- | 5 | 15540.00 | 43.82 | 54.00 | -10.18 | 28.53 | 15.29 | Average | --- | 6 | 15540.00 | 57.37 | 74.00 | -16.63 | 42.08 | 15.29 | Peak | --- |
| Freq. | Emission level | Limit | Margin | SA reading | Factor | Remark | ANT High | Turn Table | | | | | | | | | | | | | | | | | | | | | | | | | | | | | | | | | | | | | | | | | | | | | | | | | | | | | | | | | | | | | | | | | |
| MHz | dBuV/m | dBuV/m | dB | dBuV | dB | | cm | deg | | | | | | | | | | | | | | | | | | | | | | | | | | | | | | | | | | | | | | | | | | | | | | | | | | | | | | | | | | | | | | | | | |
| 1 | 5150.00 | 44.89 | 54.00 | -9.11 | 39.18 | 5.71 | Average | --- | | | | | | | | | | | | | | | | | | | | | | | | | | | | | | | | | | | | | | | | | | | | | | | | | | | | | | | | | | | | | | | | | |
| 2 | 5150.00 | 57.05 | 74.00 | -16.95 | 51.34 | 5.71 | Peak | --- | | | | | | | | | | | | | | | | | | | | | | | | | | | | | | | | | | | | | | | | | | | | | | | | | | | | | | | | | | | | | | | | | |
| 3 | 10360.00 | 47.81 | 54.00 | -6.19 | 33.37 | 14.44 | Average | --- | | | | | | | | | | | | | | | | | | | | | | | | | | | | | | | | | | | | | | | | | | | | | | | | | | | | | | | | | | | | | | | | | |
| 4 | 10360.00 | 63.46 | 74.00 | -10.54 | 49.02 | 14.44 | Peak | --- | | | | | | | | | | | | | | | | | | | | | | | | | | | | | | | | | | | | | | | | | | | | | | | | | | | | | | | | | | | | | | | | | |
| 5 | 15540.00 | 43.82 | 54.00 | -10.18 | 28.53 | 15.29 | Average | --- | | | | | | | | | | | | | | | | | | | | | | | | | | | | | | | | | | | | | | | | | | | | | | | | | | | | | | | | | | | | | | | | | |
| 6 | 15540.00 | 57.37 | 74.00 | -16.63 | 42.08 | 15.29 | Peak | --- | | | | | | | | | | | | | | | | | | | | | | | | | | | | | | | | | | | | | | | | | | | | | | | | | | | | | | | | | | | | | | | | | |
| <p>Note 1: Emission Level (dBuV/m) = SA Reading (dBuV/m) + Factor* (dB) *Factor includes antenna factor , cable loss and amplifier gain Note 2: Margin (dB) = Emission level (dBuV/m) – Limit (dBuV/m).</p> | | | | | | | | | | | | | | | | | | | | | | | | | | | | | | | | | | | | | | | | | | | | | | | | | | | | | | | | | | | | | | | | | | | | | | | | | |

| | | | |
|---------------------|----------|-------------------------|------|
| Modulation | 11a | Test Freq. (MHz) | 5180 |
| Polarization | Vertical | | |

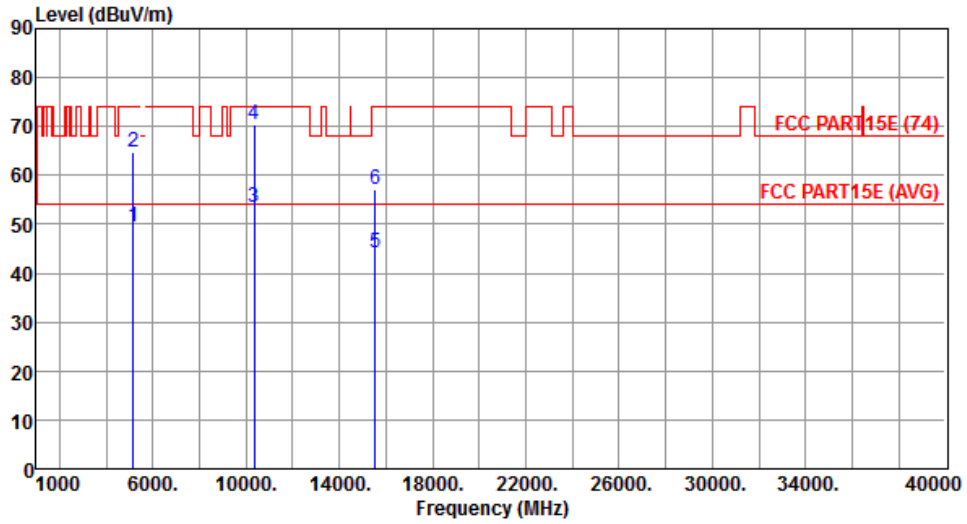

| | Freq. MHz | Emission level dBuV/m | Limit dBuV/m | Margin dB | SA reading dBuV | Factor dB | Remark | ANT High cm | Turn Table deg |
|---|--------------|-----------------------------|-----------------|--------------|-----------------------|--------------|---------|-------------------|----------------------|
| 1 | 5150.00 | 49.53 | 54.00 | -4.47 | 43.82 | 5.71 | Average | --- | --- |
| 2 | 5150.00 | 64.61 | 74.00 | -9.39 | 58.90 | 5.71 | Peak | --- | --- |
| 3 | 10360.00 | 53.55 | 54.00 | -0.45 | 39.11 | 14.44 | Average | --- | --- |
| 4 | 10360.00 | 70.56 | 74.00 | -3.44 | 56.12 | 14.44 | Peak | --- | --- |
| 5 | 15540.00 | 44.07 | 54.00 | -9.93 | 28.78 | 15.29 | Average | --- | --- |
| 6 | 15540.00 | 57.09 | 74.00 | -16.91 | 41.80 | 15.29 | Peak | --- | --- |

Note 1: Emission Level (dBuV/m) = SA Reading (dBuV/m) + Factor* (dB)

*Factor includes antenna factor , cable loss and amplifier gain

Note 2: Margin (dB) = Emission level (dBuV/m) – Limit (dBuV/m).

| | | | |
|---------------------|------------|-------------------------|------|
| Modulation | 11a | Test Freq. (MHz) | 5200 |
| Polarization | Horizontal | | |

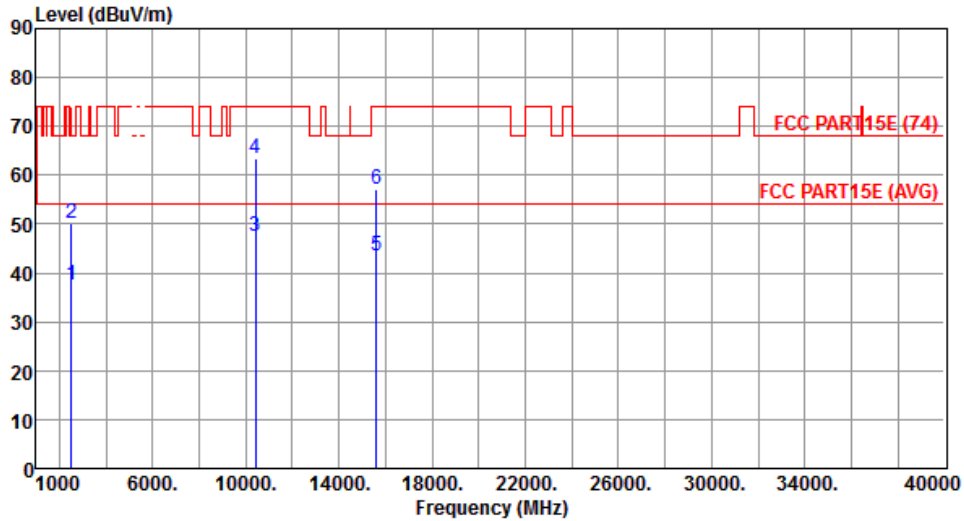

| | Freq. MHz | Emission level dBuV/m | Limit dBuV/m | Margin dB | SA reading dBuV | Factor dB | Remark | ANT High cm | Turn Table deg |
|---|--------------|-----------------------------|-----------------|--------------|-----------------------|--------------|---------|-------------------|----------------------|
| 1 | 2500.00 | 37.45 | 54.00 | -16.55 | 39.76 | -2.31 | Average | --- | --- |
| 2 | 2500.00 | 50.10 | 74.00 | -23.90 | 52.41 | -2.31 | Peak | --- | --- |
| 3 | 10400.00 | 47.36 | 54.00 | -6.64 | 32.86 | 14.50 | Average | --- | --- |
| 4 | 10400.00 | 63.28 | 74.00 | -10.72 | 48.78 | 14.50 | Peak | --- | --- |
| 5 | 15600.00 | 43.57 | 54.00 | -10.43 | 28.40 | 15.17 | Average | --- | --- |
| 6 | 15600.00 | 57.15 | 74.00 | -16.85 | 41.98 | 15.17 | Peak | --- | --- |

Note 1: Emission Level (dBuV/m) = SA Reading (dBuV/m) + Factor* (dB)

*Factor includes antenna factor , cable loss and amplifier gain

Note 2: Margin (dB) = Emission level (dBuV/m) – Limit (dBuV/m).

| | | | |
|---------------------|----------|-------------------------|------|
| Modulation | 11a | Test Freq. (MHz) | 5200 |
| Polarization | Vertical | | |

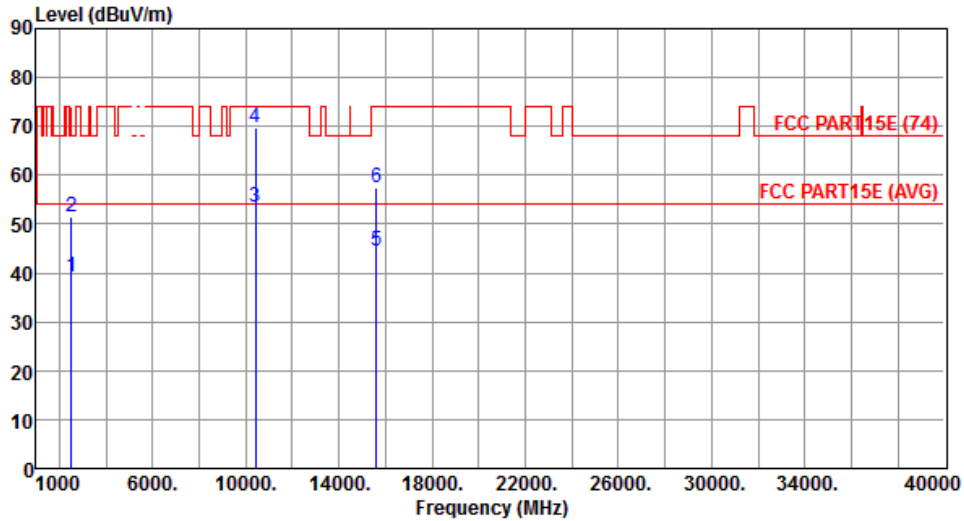

| | Freq. MHz | Emission level dBuV/m | Limit dBuV/m | Margin dB | SA reading dBuV | Factor dB | Remark | ANT High cm | Turn Table deg |
|---|--------------|-----------------------------|-----------------|--------------|-----------------------|--------------|---------|-------------------|----------------------|
| 1 | 2500.00 | 39.28 | 54.00 | -14.72 | 41.59 | -2.31 | Average | --- | --- |
| 2 | 2500.00 | 51.36 | 74.00 | -22.64 | 53.67 | -2.31 | Peak | --- | --- |
| 3 | 10400.00 | 53.51 | 54.00 | -0.49 | 39.01 | 14.50 | Average | --- | --- |
| 4 | 10400.00 | 69.81 | 74.00 | -4.19 | 55.31 | 14.50 | Peak | --- | --- |
| 5 | 15600.00 | 44.34 | 54.00 | -9.66 | 29.17 | 15.17 | Average | --- | --- |
| 6 | 15600.00 | 57.48 | 74.00 | -16.52 | 42.31 | 15.17 | Peak | --- | --- |

Note 1: Emission Level (dBuV/m) = SA Reading (dBuV/m) + Factor* (dB)

*Factor includes antenna factor , cable loss and amplifier gain

Note 2: Margin (dB) = Emission level (dBuV/m) – Limit (dBuV/m).

| | | | |
|---------------------|------------|-------------------------|------|
| Modulation | 11a | Test Freq. (MHz) | 5240 |
| Polarization | Horizontal | | |

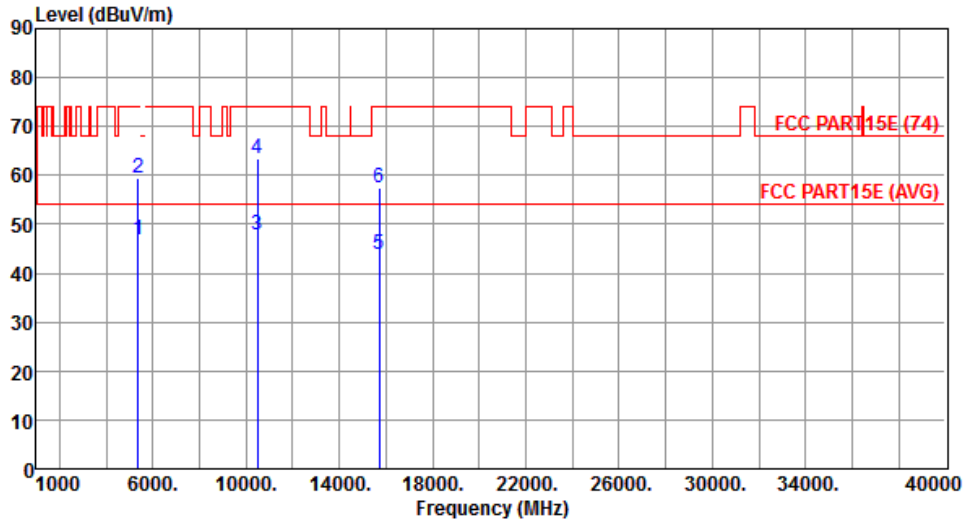

| | Freq. MHz | Emission level dBuV/m | Limit dBuV/m | Margin dB | SA reading dBuV | Factor dB | Remark | ANT High cm | Turn Table deg |
|---|--------------|-----------------------------|-----------------|--------------|-----------------------|--------------|---------|-------------------|----------------------|
| 1 | 5350.00 | 46.71 | 54.00 | -7.29 | 40.72 | 5.99 | Average | --- | --- |
| 2 | 5350.00 | 59.42 | 74.00 | -14.58 | 53.43 | 5.99 | Peak | --- | --- |
| 3 | 10480.00 | 47.69 | 54.00 | -6.31 | 33.06 | 14.63 | Average | --- | --- |
| 4 | 10480.00 | 63.58 | 74.00 | -10.42 | 48.95 | 14.63 | Peak | --- | --- |
| 5 | 15720.00 | 43.72 | 54.00 | -10.28 | 28.80 | 14.92 | Average | --- | --- |
| 6 | 15720.00 | 57.39 | 74.00 | -16.61 | 42.47 | 14.92 | Peak | --- | --- |

Note 1: Emission Level (dBuV/m) = SA Reading (dBuV/m) + Factor* (dB)

*Factor includes antenna factor , cable loss and amplifier gain

Note 2: Margin (dB) = Emission level (dBuV/m) – Limit (dBuV/m).

| | | | |
|---------------------|----------|-------------------------|------|
| Modulation | 11a | Test Freq. (MHz) | 5240 |
| Polarization | Vertical | | |

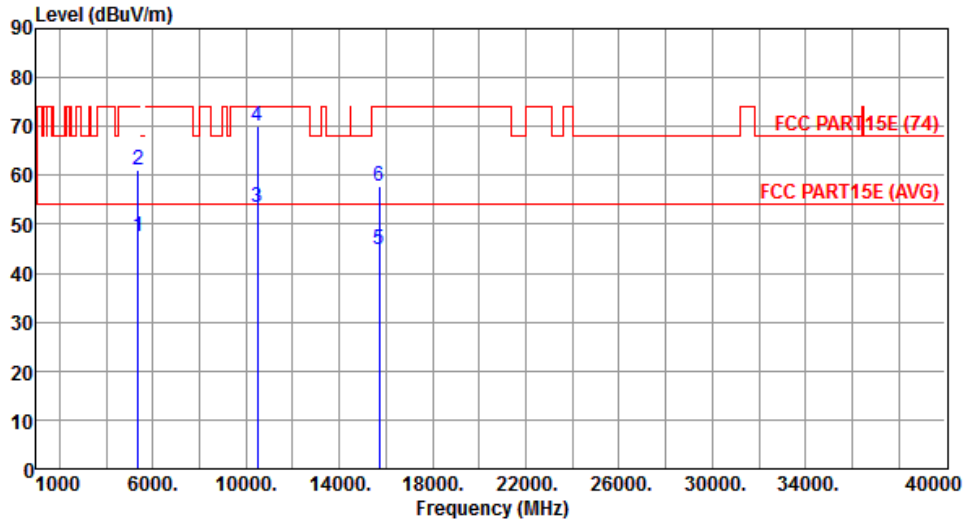

| | Freq. MHz | Emission level dBuV/m | Limit dBuV/m | Margin dB | SA reading dBuV | Factor dB | Remark | ANT High cm | Turn Table deg |
|---|--------------|-----------------------------|-----------------|--------------|-----------------------|--------------|---------|-------------------|----------------------|
| 1 | 5350.00 | 47.58 | 54.00 | -6.42 | 41.59 | 5.99 | Average | --- | --- |
| 2 | 5350.00 | 60.95 | 74.00 | -13.05 | 54.96 | 5.99 | Peak | --- | --- |
| 3 | 10480.00 | 53.55 | 54.00 | -0.45 | 38.92 | 14.63 | Average | --- | --- |
| 4 | 10480.00 | 69.92 | 74.00 | -4.08 | 55.29 | 14.63 | Peak | --- | --- |
| 5 | 15720.00 | 44.68 | 54.00 | -9.32 | 29.76 | 14.92 | Average | --- | --- |
| 6 | 15720.00 | 57.73 | 74.00 | -16.27 | 42.81 | 14.92 | Peak | --- | --- |

Note 1: Emission Level (dBuV/m) = SA Reading (dBuV/m) + Factor* (dB)

*Factor includes antenna factor , cable loss and amplifier gain

Note 2: Margin (dB) = Emission level (dBuV/m) – Limit (dBuV/m).

3.5.6 Transmitter Radiated Unwanted Emissions (Above 1GHz) for VHT20

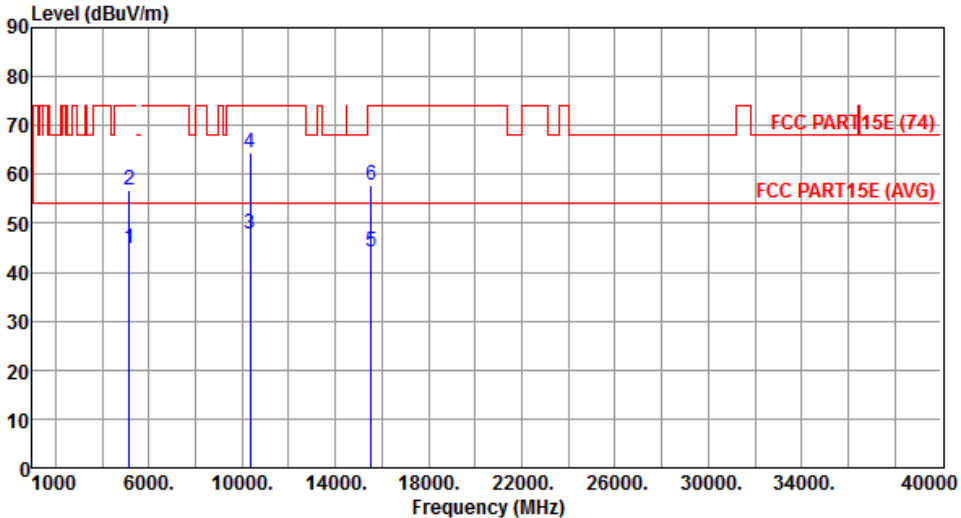
| Modulation | VHT20 | Test Freq. (MHz) | 5180 | | | | | | | | | | | | | | | | | | | | | | | | | | | | | | | | | | | | | | | | | | | | | | | | | | | | | | | | | | | | | | | | | | | | | | |
|---|--|------------------|----------------|------------|--------|------------|----------|------------|----------|------------|-----|--------|--------|----|------|----|--|----|-----|---|---------|-------|-------|-------|-------|------|---------|-----|---|---------|-------|-------|--------|-------|------|------|-----|---|----------|-------|-------|-------|-------|-------|---------|-----|---|----------|-------|-------|-------|-------|-------|------|-----|---|----------|-------|-------|-------|-------|-------|---------|-----|---|----------|-------|-------|--------|-------|-------|------|-----|
| Polarization | Horizontal | | | | | | | | | | | | | | | | | | | | | | | | | | | | | | | | | | | | | | | | | | | | | | | | | | | | | | | | | | | | | | | | | | | | | | | | |
|  | | | | | | | | | | | | | | | | | | | | | | | | | | | | | | | | | | | | | | | | | | | | | | | | | | | | | | | | | | | | | | | | | | | | | | | | | |
| | <table border="1"> <thead> <tr> <th>Freq.</th> <th>Emission level</th> <th>Limit</th> <th>Margin</th> <th>SA reading</th> <th>Factor</th> <th>Remark</th> <th>ANT High</th> <th>Turn Table</th> </tr> <tr> <th>MHz</th> <th>dBuV/m</th> <th>dBuV/m</th> <th>dB</th> <th>dBuV</th> <th>dB</th> <th></th> <th>cm</th> <th>deg</th> </tr> </thead> <tbody> <tr> <td>1</td> <td>5150.00</td> <td>44.78</td> <td>54.00</td> <td>-9.22</td> <td>39.07</td> <td>5.71</td> <td>Average</td> <td>---</td> </tr> <tr> <td>2</td> <td>5150.00</td> <td>56.74</td> <td>74.00</td> <td>-17.26</td> <td>51.03</td> <td>5.71</td> <td>Peak</td> <td>---</td> </tr> <tr> <td>3</td> <td>10360.00</td> <td>47.94</td> <td>54.00</td> <td>-6.06</td> <td>33.50</td> <td>14.44</td> <td>Average</td> <td>---</td> </tr> <tr> <td>4</td> <td>10360.00</td> <td>64.55</td> <td>74.00</td> <td>-9.45</td> <td>50.11</td> <td>14.44</td> <td>Peak</td> <td>---</td> </tr> <tr> <td>5</td> <td>15540.00</td> <td>44.27</td> <td>54.00</td> <td>-9.73</td> <td>28.98</td> <td>15.29</td> <td>Average</td> <td>---</td> </tr> <tr> <td>6</td> <td>15540.00</td> <td>57.89</td> <td>74.00</td> <td>-16.11</td> <td>42.60</td> <td>15.29</td> <td>Peak</td> <td>---</td> </tr> </tbody> </table> | Freq. | Emission level | Limit | Margin | SA reading | Factor | Remark | ANT High | Turn Table | MHz | dBuV/m | dBuV/m | dB | dBuV | dB | | cm | deg | 1 | 5150.00 | 44.78 | 54.00 | -9.22 | 39.07 | 5.71 | Average | --- | 2 | 5150.00 | 56.74 | 74.00 | -17.26 | 51.03 | 5.71 | Peak | --- | 3 | 10360.00 | 47.94 | 54.00 | -6.06 | 33.50 | 14.44 | Average | --- | 4 | 10360.00 | 64.55 | 74.00 | -9.45 | 50.11 | 14.44 | Peak | --- | 5 | 15540.00 | 44.27 | 54.00 | -9.73 | 28.98 | 15.29 | Average | --- | 6 | 15540.00 | 57.89 | 74.00 | -16.11 | 42.60 | 15.29 | Peak | --- |
| Freq. | Emission level | Limit | Margin | SA reading | Factor | Remark | ANT High | Turn Table | | | | | | | | | | | | | | | | | | | | | | | | | | | | | | | | | | | | | | | | | | | | | | | | | | | | | | | | | | | | | | | | | |
| MHz | dBuV/m | dBuV/m | dB | dBuV | dB | | cm | deg | | | | | | | | | | | | | | | | | | | | | | | | | | | | | | | | | | | | | | | | | | | | | | | | | | | | | | | | | | | | | | | | | |
| 1 | 5150.00 | 44.78 | 54.00 | -9.22 | 39.07 | 5.71 | Average | --- | | | | | | | | | | | | | | | | | | | | | | | | | | | | | | | | | | | | | | | | | | | | | | | | | | | | | | | | | | | | | | | | | |
| 2 | 5150.00 | 56.74 | 74.00 | -17.26 | 51.03 | 5.71 | Peak | --- | | | | | | | | | | | | | | | | | | | | | | | | | | | | | | | | | | | | | | | | | | | | | | | | | | | | | | | | | | | | | | | | | |
| 3 | 10360.00 | 47.94 | 54.00 | -6.06 | 33.50 | 14.44 | Average | --- | | | | | | | | | | | | | | | | | | | | | | | | | | | | | | | | | | | | | | | | | | | | | | | | | | | | | | | | | | | | | | | | | |
| 4 | 10360.00 | 64.55 | 74.00 | -9.45 | 50.11 | 14.44 | Peak | --- | | | | | | | | | | | | | | | | | | | | | | | | | | | | | | | | | | | | | | | | | | | | | | | | | | | | | | | | | | | | | | | | | |
| 5 | 15540.00 | 44.27 | 54.00 | -9.73 | 28.98 | 15.29 | Average | --- | | | | | | | | | | | | | | | | | | | | | | | | | | | | | | | | | | | | | | | | | | | | | | | | | | | | | | | | | | | | | | | | | |
| 6 | 15540.00 | 57.89 | 74.00 | -16.11 | 42.60 | 15.29 | Peak | --- | | | | | | | | | | | | | | | | | | | | | | | | | | | | | | | | | | | | | | | | | | | | | | | | | | | | | | | | | | | | | | | | | |
| <p>Note 1: Emission Level (dBuV/m) = SA Reading (dBuV/m) + Factor* (dB) *Factor includes antenna factor , cable loss and amplifier gain Note 2: Margin (dB) = Emission level (dBuV/m) – Limit (dBuV/m).</p> | | | | | | | | | | | | | | | | | | | | | | | | | | | | | | | | | | | | | | | | | | | | | | | | | | | | | | | | | | | | | | | | | | | | | | | | | |

| | | | |
|---------------------|----------|-------------------------|------|
| Modulation | VHT20 | Test Freq. (MHz) | 5180 |
| Polarization | Vertical | | |

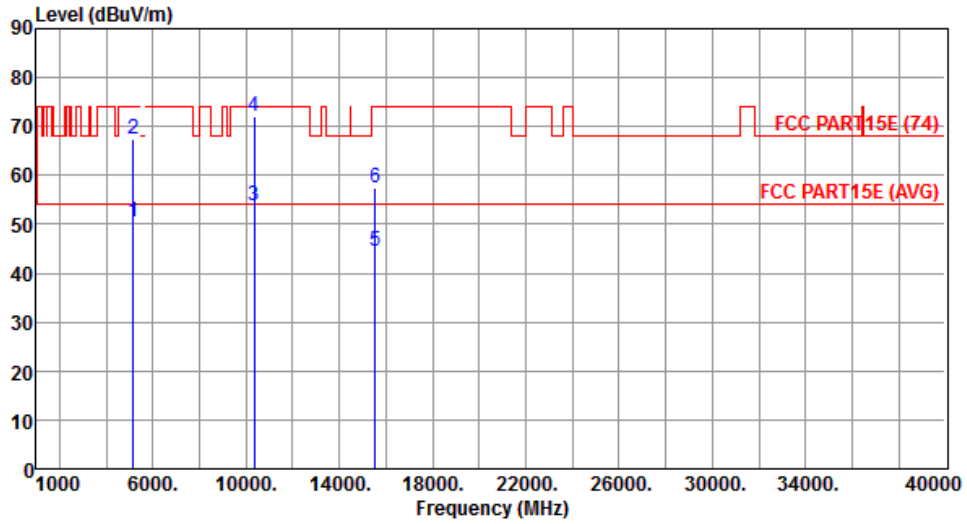

| | Freq. MHz | Emission level dBuV/m | Limit dBuV/m | Margin dB | SA reading dBuV | Factor dB | Remark | ANT High cm | Turn Table deg |
|---|--------------|-----------------------------|-----------------|--------------|-----------------------|--------------|---------|-------------------|----------------------|
| 1 | 5150.00 | 50.48 | 54.00 | -3.52 | 44.77 | 5.71 | Average | --- | --- |
| 2 | 5150.00 | 67.40 | 74.00 | -6.60 | 61.69 | 5.71 | Peak | --- | --- |
| 3 | 10360.00 | 53.86 | 54.00 | -0.14 | 39.42 | 14.44 | Average | --- | --- |
| 4 | 10360.00 | 72.14 | 74.00 | -1.86 | 57.70 | 14.44 | Peak | --- | --- |
| 5 | 15540.00 | 44.37 | 54.00 | -9.63 | 29.08 | 15.29 | Average | --- | --- |
| 6 | 15540.00 | 57.52 | 74.00 | -16.48 | 42.23 | 15.29 | Peak | --- | --- |

Note 1: Emission Level (dBuV/m) = SA Reading (dBuV/m) + Factor* (dB)

*Factor includes antenna factor , cable loss and amplifier gain

Note 2: Margin (dB) = Emission level (dBuV/m) – Limit (dBuV/m).

| | | | |
|---------------------|------------|-------------------------|------|
| Modulation | VHT20 | Test Freq. (MHz) | 5200 |
| Polarization | Horizontal | | |

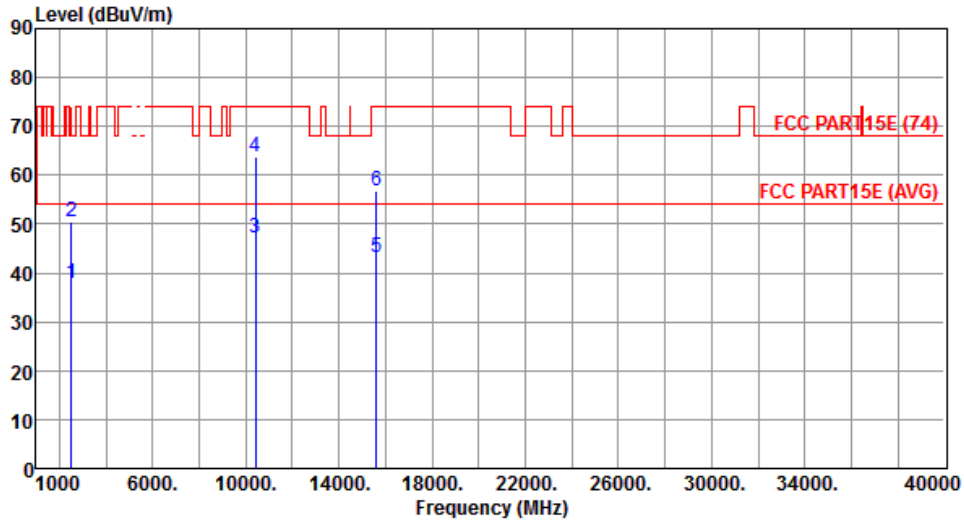

| | Freq. MHz | Emission level dBuV/m | Limit dBuV/m | Margin dB | SA reading dBuV | Factor dB | Remark | ANT High cm | Turn Table deg |
|---|--------------|-----------------------------|-----------------|--------------|-----------------------|--------------|---------|-------------------|----------------------|
| 1 | 2500.00 | 37.89 | 54.00 | -16.11 | 40.20 | -2.31 | Average | --- | --- |
| 2 | 2500.00 | 50.47 | 74.00 | -23.53 | 52.78 | -2.31 | Peak | --- | --- |
| 3 | 10400.00 | 47.08 | 54.00 | -6.92 | 32.58 | 14.50 | Average | --- | --- |
| 4 | 10400.00 | 63.65 | 74.00 | -10.35 | 49.15 | 14.50 | Peak | --- | --- |
| 5 | 15600.00 | 43.21 | 54.00 | -10.79 | 28.04 | 15.17 | Average | --- | --- |
| 6 | 15600.00 | 56.86 | 74.00 | -17.14 | 41.69 | 15.17 | Peak | --- | --- |

Note 1: Emission Level (dBuV/m) = SA Reading (dBuV/m) + Factor* (dB)

*Factor includes antenna factor , cable loss and amplifier gain

Note 2: Margin (dB) = Emission level (dBuV/m) – Limit (dBuV/m).

| | | | |
|---------------------|----------|-------------------------|------|
| Modulation | VHT20 | Test Freq. (MHz) | 5200 |
| Polarization | Vertical | | |

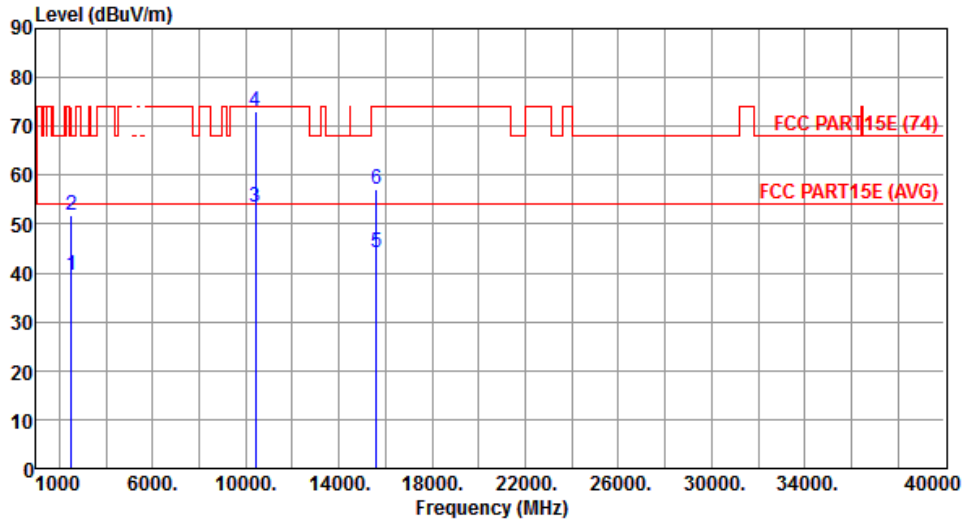

| | Freq. MHz | Emission level dBuV/m | Limit dBuV/m | Margin dB | SA reading dBuV | Factor dB | Remark | ANT High cm | Turn Table deg |
|---|--------------|-----------------------------|-----------------|--------------|-----------------------|--------------|---------|-------------------|----------------------|
| 1 | 2500.00 | 39.66 | 54.00 | -14.34 | 41.97 | -2.31 | Average | --- | --- |
| 2 | 2500.00 | 51.78 | 74.00 | -22.22 | 54.09 | -2.31 | Peak | --- | --- |
| 3 | 10400.00 | 53.52 | 54.00 | -0.48 | 39.02 | 14.50 | Average | --- | --- |
| 4 | 10400.00 | 72.90 | 74.00 | -1.10 | 58.40 | 14.50 | Peak | --- | --- |
| 5 | 15600.00 | 44.02 | 54.00 | -9.98 | 28.85 | 15.17 | Average | --- | --- |
| 6 | 15600.00 | 57.19 | 74.00 | -16.81 | 42.02 | 15.17 | Peak | --- | --- |

Note 1: Emission Level (dBuV/m) = SA Reading (dBuV/m) + Factor* (dB)

*Factor includes antenna factor , cable loss and amplifier gain

Note 2: Margin (dB) = Emission level (dBuV/m) – Limit (dBuV/m).

| | | | |
|---------------------|------------|-------------------------|------|
| Modulation | VHT20 | Test Freq. (MHz) | 5240 |
| Polarization | Horizontal | | |

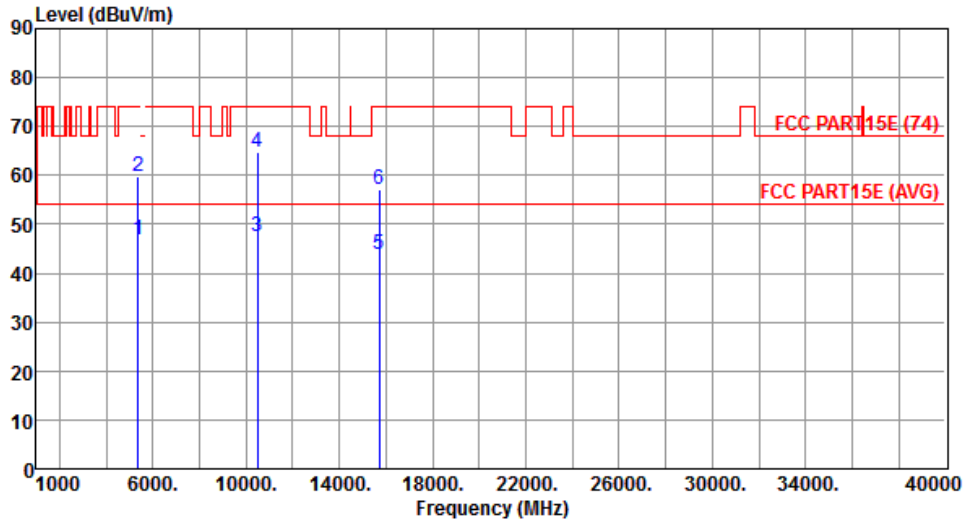

| | Freq. MHz | Emission level dBuV/m | Limit dBuV/m | Margin dB | SA reading dBuV | Factor dB | Remark | ANT High cm | Turn Table deg |
|---|--------------|-----------------------------|-----------------|--------------|-----------------------|--------------|---------|-------------------|----------------------|
| 1 | 5350.00 | 46.94 | 54.00 | -7.06 | 40.95 | 5.99 | Average | --- | --- |
| 2 | 5350.00 | 59.89 | 74.00 | -14.11 | 53.90 | 5.99 | Peak | --- | --- |
| 3 | 10480.00 | 47.36 | 54.00 | -6.64 | 32.73 | 14.63 | Average | --- | --- |
| 4 | 10480.00 | 64.78 | 74.00 | -9.22 | 50.15 | 14.63 | Peak | --- | --- |
| 5 | 15720.00 | 43.84 | 54.00 | -10.16 | 28.92 | 14.92 | Average | --- | --- |
| 6 | 15720.00 | 57.15 | 74.00 | -16.85 | 42.23 | 14.92 | Peak | --- | --- |

Note 1: Emission Level (dBuV/m) = SA Reading (dBuV/m) + Factor* (dB)

*Factor includes antenna factor , cable loss and amplifier gain

Note 2: Margin (dB) = Emission level (dBuV/m) – Limit (dBuV/m).

| | | | |
|---------------------|----------|-------------------------|------|
| Modulation | VHT20 | Test Freq. (MHz) | 5240 |
| Polarization | Vertical | | |

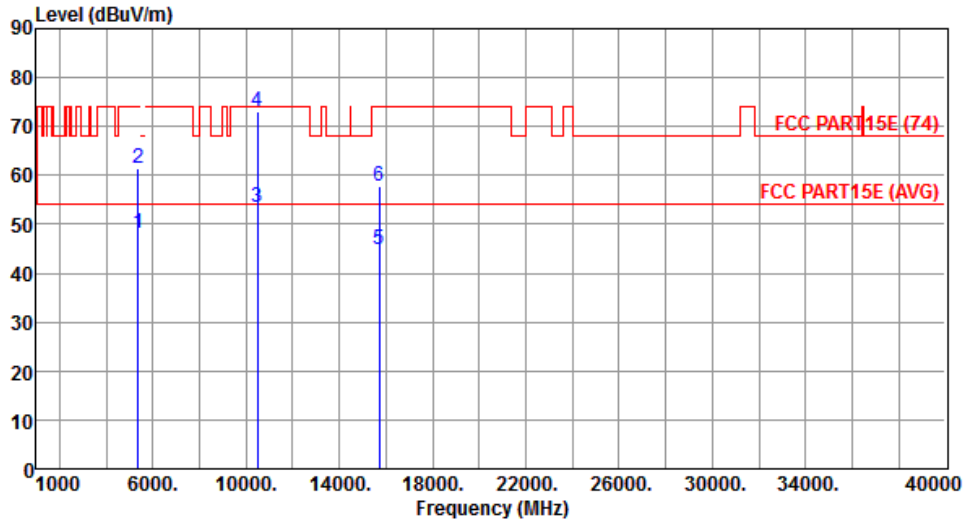

| | Freq. MHz | Emission level dBuV/m | Limit dBuV/m | Margin dB | SA reading dBuV | Factor dB | Remark | ANT High cm | Turn Table deg |
|---|--------------|-----------------------------|-----------------|--------------|-----------------------|--------------|---------|-------------------|----------------------|
| 1 | 5350.00 | 47.99 | 54.00 | -6.01 | 42.00 | 5.99 | Average | --- | --- |
| 2 | 5350.00 | 61.56 | 74.00 | -12.44 | 55.57 | 5.99 | Peak | --- | --- |
| 3 | 10480.00 | 53.54 | 54.00 | -0.46 | 38.91 | 14.63 | Average | --- | --- |
| 4 | 10480.00 | 73.17 | 74.00 | -0.83 | 58.54 | 14.63 | Peak | --- | --- |
| 5 | 15720.00 | 44.68 | 54.00 | -9.32 | 29.76 | 14.92 | Average | --- | --- |
| 6 | 15720.00 | 57.73 | 74.00 | -16.27 | 42.81 | 14.92 | Peak | --- | --- |

Note 1: Emission Level (dBuV/m) = SA Reading (dBuV/m) + Factor* (dB)

*Factor includes antenna factor , cable loss and amplifier gain

Note 2: Margin (dB) = Emission level (dBuV/m) – Limit (dBuV/m).

3.5.7 Transmitter Radiated Unwanted Emissions (Above 1GHz) for VHT40

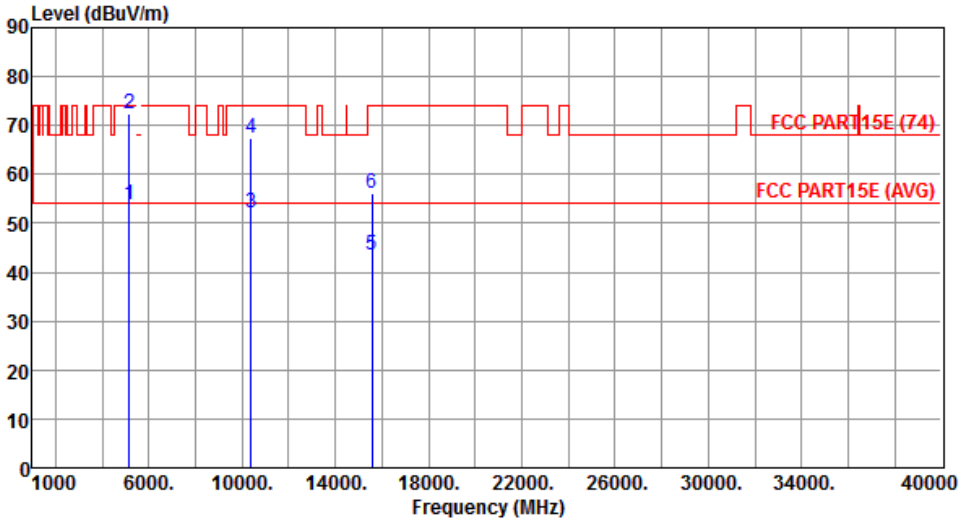
| Modulation | VHT40 | Test Freq. (MHz) | 5190 | | | | | | |
|---|----------------|------------------|--------|------------|--------|--------|-------------|----------------|-----|
| Polarization | Horizontal | | | | | | | | |
|  | | | | | | | | | |
| Freq. | Emission level | Limit | Margin | SA reading | Factor | Remark | ANT High cm | Turn Table deg | |
| MHz | dBuV/m | dBuV/m | dB | dBuV | dB | | | | |
| 1 | 5150.00 | 53.90 | 54.00 | -0.10 | 48.19 | 5.71 | Average | --- | --- |
| 2 | 5150.00 | 72.37 | 74.00 | -1.63 | 66.66 | 5.71 | Peak | --- | --- |
| 3 | 10380.00 | 52.20 | 54.00 | -1.80 | 37.74 | 14.46 | Average | --- | --- |
| 4 | 10380.00 | 67.41 | 74.00 | -6.59 | 52.95 | 14.46 | Peak | --- | --- |
| 5 | 15570.00 | 43.56 | 54.00 | -10.44 | 28.33 | 15.23 | Average | --- | --- |
| 6 | 15570.00 | 55.97 | 74.00 | -18.03 | 40.74 | 15.23 | Peak | --- | --- |

Note 1: Emission Level (dBuV/m) = SA Reading (dBuV/m) + Factor* (dB)
*Factor includes antenna factor , cable loss and amplifier gain
Note 2: Margin (dB) = Emission level (dBuV/m) – Limit (dBuV/m).

| | | | |
|---------------------|----------|-------------------------|------|
| Modulation | VHT40 | Test Freq. (MHz) | 5190 |
| Polarization | Vertical | | |

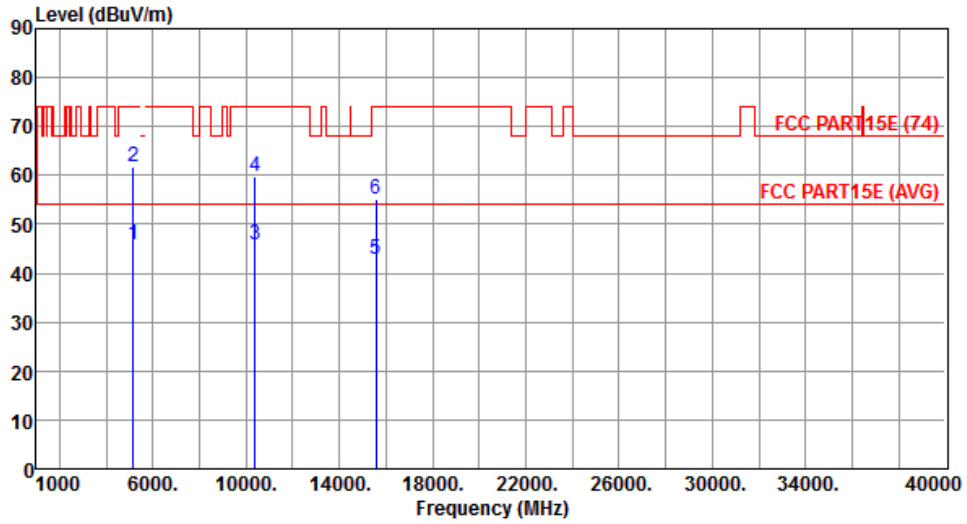

| | Freq. MHz | Emission level dBuV/m | Limit dBuV/m | Margin dB | SA reading dBuV | Factor dB | Remark | ANT High cm | Turn Table deg |
|---|--------------|-----------------------------|-----------------|--------------|-----------------------|--------------|---------|-------------------|----------------------|
| 1 | 5150.00 | 45.92 | 54.00 | -8.08 | 40.21 | 5.71 | Average | --- | --- |
| 2 | 5150.00 | 61.85 | 74.00 | -12.15 | 56.14 | 5.71 | Peak | --- | --- |
| 3 | 10380.00 | 45.97 | 54.00 | -8.03 | 31.51 | 14.46 | Average | --- | --- |
| 4 | 10380.00 | 59.84 | 74.00 | -14.16 | 45.38 | 14.46 | Peak | --- | --- |
| 5 | 15570.00 | 42.82 | 54.00 | -11.18 | 27.59 | 15.23 | Average | --- | --- |
| 6 | 15570.00 | 55.10 | 74.00 | -18.90 | 39.87 | 15.23 | Peak | --- | --- |

Note 1: Emission Level (dBuV/m) = SA Reading (dBuV/m) + Factor* (dB)

*Factor includes antenna factor , cable loss and amplifier gain

Note 2: Margin (dB) = Emission level (dBuV/m) – Limit (dBuV/m).

| | | | |
|---------------------|------------|-------------------------|------|
| Modulation | VHT40 | Test Freq. (MHz) | 5230 |
| Polarization | Horizontal | | |

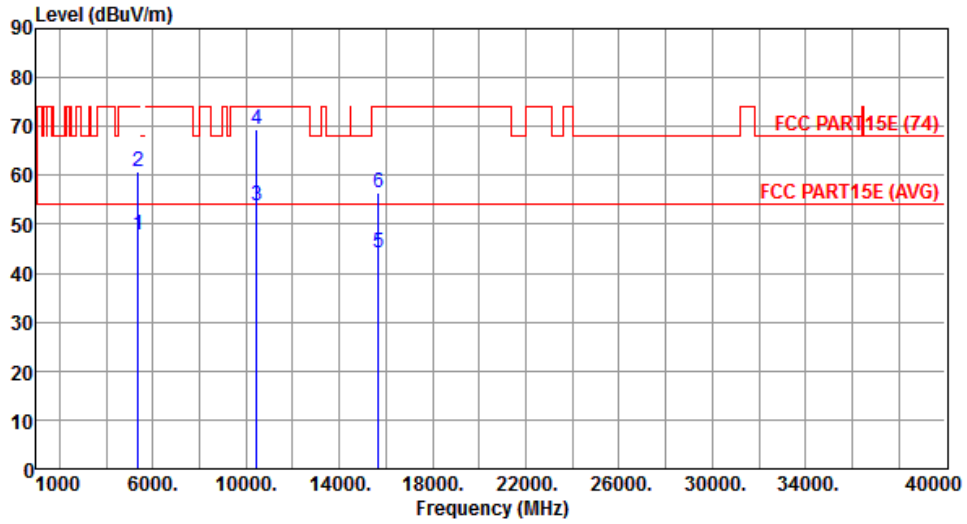

| | Freq. MHz | Emission level dBuV/m | Limit dBuV/m | Margin dB | SA reading dBuV | Factor dB | Remark | ANT High cm | Turn Table deg |
|---|--------------|-----------------------------|-----------------|--------------|-----------------------|--------------|---------|-------------------|----------------------|
| 1 | 5350.00 | 47.67 | 54.00 | -6.33 | 41.68 | 5.99 | Average | --- | --- |
| 2 | 5350.00 | 60.73 | 74.00 | -13.27 | 54.74 | 5.99 | Peak | --- | --- |
| 3 | 10460.00 | 53.87 | 54.00 | -0.13 | 39.27 | 14.60 | Average | --- | --- |
| 4 | 10460.00 | 69.46 | 74.00 | -4.54 | 54.86 | 14.60 | Peak | --- | --- |
| 5 | 15690.00 | 44.24 | 54.00 | -9.76 | 29.26 | 14.98 | Average | --- | --- |
| 6 | 15690.00 | 56.60 | 74.00 | -17.40 | 41.62 | 14.98 | Peak | --- | --- |

Note 1: Emission Level (dBuV/m) = SA Reading (dBuV/m) + Factor* (dB)

*Factor includes antenna factor , cable loss and amplifier gain

Note 2: Margin (dB) = Emission level (dBuV/m) – Limit (dBuV/m).

| | | | |
|---------------------|----------|-------------------------|------|
| Modulation | VHT40 | Test Freq. (MHz) | 5230 |
| Polarization | Vertical | | |

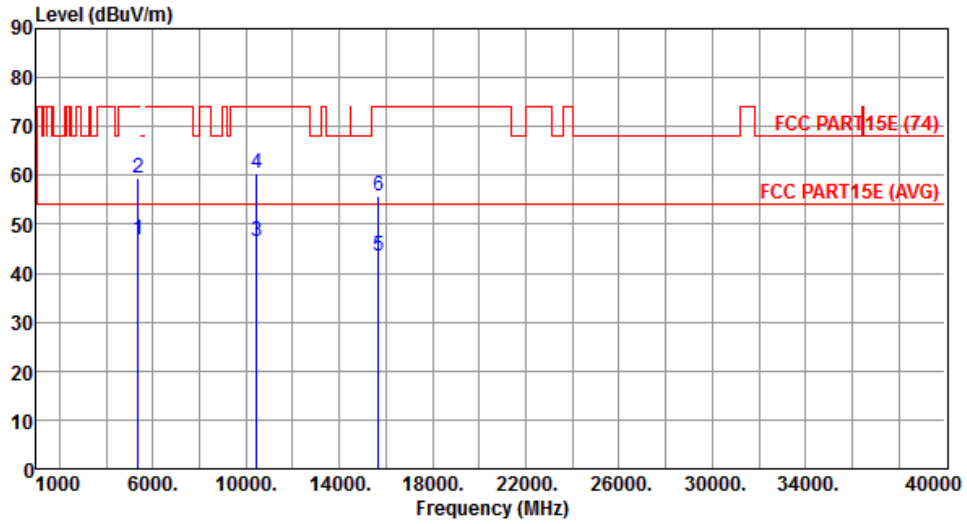

| | Freq. MHz | Emission level dBuV/m | Limit dBuV/m | Margin dB | SA reading dBuV | Factor dB | Remark | ANT High cm | Turn Table deg |
|---|--------------|-----------------------------|-----------------|--------------|-----------------------|--------------|---------|-------------------|----------------------|
| 1 | 5350.00 | 46.86 | 54.00 | -7.14 | 40.87 | 5.99 | Average | --- | --- |
| 2 | 5350.00 | 59.40 | 74.00 | -14.60 | 53.41 | 5.99 | Peak | --- | --- |
| 3 | 10460.00 | 46.63 | 54.00 | -7.37 | 32.03 | 14.60 | Average | --- | --- |
| 4 | 10460.00 | 60.55 | 74.00 | -13.45 | 45.95 | 14.60 | Peak | --- | --- |
| 5 | 15690.00 | 43.40 | 54.00 | -10.60 | 28.42 | 14.98 | Average | --- | --- |
| 6 | 15690.00 | 55.70 | 74.00 | -18.30 | 40.72 | 14.98 | Peak | --- | --- |

Note 1: Emission Level (dBuV/m) = SA Reading (dBuV/m) + Factor* (dB)

*Factor includes antenna factor , cable loss and amplifier gain

Note 2: Margin (dB) = Emission level (dBuV/m) – Limit (dBuV/m).

3.5.8 Transmitter Radiated Unwanted Emissions (Above 1GHz) for VHT80

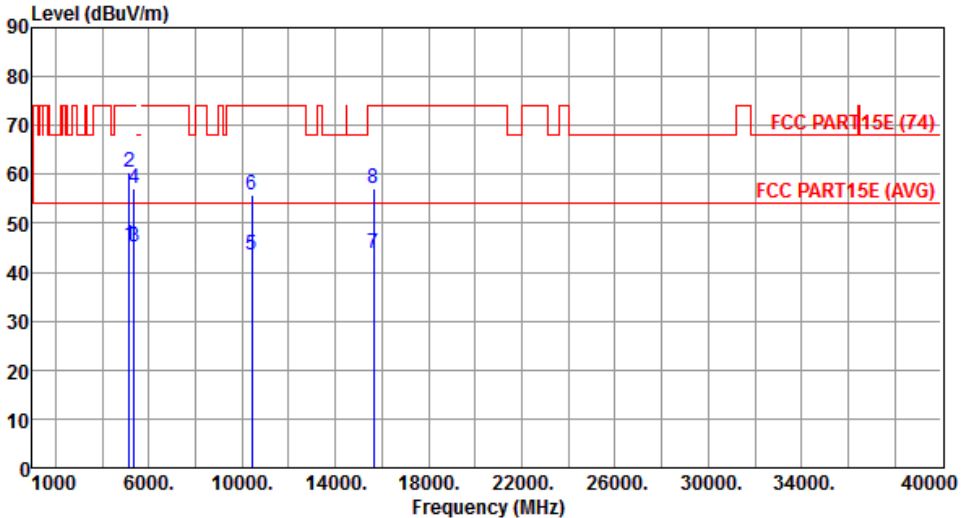
| Modulation | VHT80 | Test Freq. (MHz) | 5210 | | | | | | | | | | | | | | | | | | | | | | | | | | | | | | | | | | | | | | | | | | | | | | | | | | | | | | | | | | | | | | | | | | | | | | | | | | | | | | | | | | | | | | | | |
|---|---|------------------|----------------|------------|--------|------------|-------------|----------------|-------------|----------------|-----|--------|--------|----|------|----|--|--|--|---|---------|-------|-------|-------|-------|------|---------|-----|---|---------|-------|-------|--------|-------|------|------|-----|---|---------|-------|-------|-------|-------|------|---------|-----|---|---------|-------|-------|--------|-------|------|------|-----|---|----------|-------|-------|--------|-------|-------|---------|-----|---|----------|-------|-------|--------|-------|-------|------|-----|---|----------|-------|-------|--------|-------|-------|---------|-----|---|----------|-------|-------|--------|-------|-------|------|-----|
| Polarization | Horizontal | | | | | | | | | | | | | | | | | | | | | | | | | | | | | | | | | | | | | | | | | | | | | | | | | | | | | | | | | | | | | | | | | | | | | | | | | | | | | | | | | | | | | | | | | | |
|  | | | | | | | | | | | | | | | | | | | | | | | | | | | | | | | | | | | | | | | | | | | | | | | | | | | | | | | | | | | | | | | | | | | | | | | | | | | | | | | | | | | | | | | | | | | |
| | <table border="1"> <thead> <tr> <th>Freq.</th> <th>Emission level</th> <th>Limit</th> <th>Margin</th> <th>SA reading</th> <th>Factor</th> <th>Remark</th> <th>ANT High cm</th> <th>Turn Table deg</th> </tr> <tr> <th>MHz</th> <th>dBuV/m</th> <th>dBuV/m</th> <th>dB</th> <th>dBuV</th> <th>dB</th> <th></th> <th></th> <th></th> </tr> </thead> <tbody> <tr> <td>1</td> <td>5150.00</td> <td>45.60</td> <td>54.00</td> <td>-8.40</td> <td>39.89</td> <td>5.71</td> <td>Average</td> <td>---</td> </tr> <tr> <td>2</td> <td>5150.00</td> <td>60.41</td> <td>74.00</td> <td>-13.59</td> <td>54.70</td> <td>5.71</td> <td>Peak</td> <td>---</td> </tr> <tr> <td>3</td> <td>5350.00</td> <td>45.02</td> <td>54.00</td> <td>-8.98</td> <td>39.03</td> <td>5.99</td> <td>Average</td> <td>---</td> </tr> <tr> <td>4</td> <td>5350.00</td> <td>57.10</td> <td>74.00</td> <td>-16.90</td> <td>51.11</td> <td>5.99</td> <td>Peak</td> <td>---</td> </tr> <tr> <td>5</td> <td>10420.00</td> <td>43.36</td> <td>54.00</td> <td>-10.64</td> <td>28.82</td> <td>14.54</td> <td>Average</td> <td>---</td> </tr> <tr> <td>6</td> <td>10420.00</td> <td>55.86</td> <td>74.00</td> <td>-18.14</td> <td>41.32</td> <td>14.54</td> <td>Peak</td> <td>---</td> </tr> <tr> <td>7</td> <td>15630.00</td> <td>43.75</td> <td>54.00</td> <td>-10.25</td> <td>28.64</td> <td>15.11</td> <td>Average</td> <td>---</td> </tr> <tr> <td>8</td> <td>15630.00</td> <td>57.15</td> <td>74.00</td> <td>-16.85</td> <td>42.04</td> <td>15.11</td> <td>Peak</td> <td>---</td> </tr> </tbody> </table> | Freq. | Emission level | Limit | Margin | SA reading | Factor | Remark | ANT High cm | Turn Table deg | MHz | dBuV/m | dBuV/m | dB | dBuV | dB | | | | 1 | 5150.00 | 45.60 | 54.00 | -8.40 | 39.89 | 5.71 | Average | --- | 2 | 5150.00 | 60.41 | 74.00 | -13.59 | 54.70 | 5.71 | Peak | --- | 3 | 5350.00 | 45.02 | 54.00 | -8.98 | 39.03 | 5.99 | Average | --- | 4 | 5350.00 | 57.10 | 74.00 | -16.90 | 51.11 | 5.99 | Peak | --- | 5 | 10420.00 | 43.36 | 54.00 | -10.64 | 28.82 | 14.54 | Average | --- | 6 | 10420.00 | 55.86 | 74.00 | -18.14 | 41.32 | 14.54 | Peak | --- | 7 | 15630.00 | 43.75 | 54.00 | -10.25 | 28.64 | 15.11 | Average | --- | 8 | 15630.00 | 57.15 | 74.00 | -16.85 | 42.04 | 15.11 | Peak | --- |
| Freq. | Emission level | Limit | Margin | SA reading | Factor | Remark | ANT High cm | Turn Table deg | | | | | | | | | | | | | | | | | | | | | | | | | | | | | | | | | | | | | | | | | | | | | | | | | | | | | | | | | | | | | | | | | | | | | | | | | | | | | | | | | | | |
| MHz | dBuV/m | dBuV/m | dB | dBuV | dB | | | | | | | | | | | | | | | | | | | | | | | | | | | | | | | | | | | | | | | | | | | | | | | | | | | | | | | | | | | | | | | | | | | | | | | | | | | | | | | | | | | | | | |
| 1 | 5150.00 | 45.60 | 54.00 | -8.40 | 39.89 | 5.71 | Average | --- | | | | | | | | | | | | | | | | | | | | | | | | | | | | | | | | | | | | | | | | | | | | | | | | | | | | | | | | | | | | | | | | | | | | | | | | | | | | | | | | | | | |
| 2 | 5150.00 | 60.41 | 74.00 | -13.59 | 54.70 | 5.71 | Peak | --- | | | | | | | | | | | | | | | | | | | | | | | | | | | | | | | | | | | | | | | | | | | | | | | | | | | | | | | | | | | | | | | | | | | | | | | | | | | | | | | | | | | |
| 3 | 5350.00 | 45.02 | 54.00 | -8.98 | 39.03 | 5.99 | Average | --- | | | | | | | | | | | | | | | | | | | | | | | | | | | | | | | | | | | | | | | | | | | | | | | | | | | | | | | | | | | | | | | | | | | | | | | | | | | | | | | | | | | |
| 4 | 5350.00 | 57.10 | 74.00 | -16.90 | 51.11 | 5.99 | Peak | --- | | | | | | | | | | | | | | | | | | | | | | | | | | | | | | | | | | | | | | | | | | | | | | | | | | | | | | | | | | | | | | | | | | | | | | | | | | | | | | | | | | | |
| 5 | 10420.00 | 43.36 | 54.00 | -10.64 | 28.82 | 14.54 | Average | --- | | | | | | | | | | | | | | | | | | | | | | | | | | | | | | | | | | | | | | | | | | | | | | | | | | | | | | | | | | | | | | | | | | | | | | | | | | | | | | | | | | | |
| 6 | 10420.00 | 55.86 | 74.00 | -18.14 | 41.32 | 14.54 | Peak | --- | | | | | | | | | | | | | | | | | | | | | | | | | | | | | | | | | | | | | | | | | | | | | | | | | | | | | | | | | | | | | | | | | | | | | | | | | | | | | | | | | | | |
| 7 | 15630.00 | 43.75 | 54.00 | -10.25 | 28.64 | 15.11 | Average | --- | | | | | | | | | | | | | | | | | | | | | | | | | | | | | | | | | | | | | | | | | | | | | | | | | | | | | | | | | | | | | | | | | | | | | | | | | | | | | | | | | | | |
| 8 | 15630.00 | 57.15 | 74.00 | -16.85 | 42.04 | 15.11 | Peak | --- | | | | | | | | | | | | | | | | | | | | | | | | | | | | | | | | | | | | | | | | | | | | | | | | | | | | | | | | | | | | | | | | | | | | | | | | | | | | | | | | | | | |
| <p>Note 1: Emission Level (dBuV/m) = SA Reading (dBuV/m) + Factor* (dB) *Factor includes antenna factor , cable loss and amplifier gain Note 2: Margin (dB) = Emission level (dBuV/m) – Limit (dBuV/m).</p> | | | | | | | | | | | | | | | | | | | | | | | | | | | | | | | | | | | | | | | | | | | | | | | | | | | | | | | | | | | | | | | | | | | | | | | | | | | | | | | | | | | | | | | | | | | |

| | | | |
|---------------------|----------|-------------------------|------|
| Modulation | VHT80 | Test Freq. (MHz) | 5210 |
| Polarization | Vertical | | |

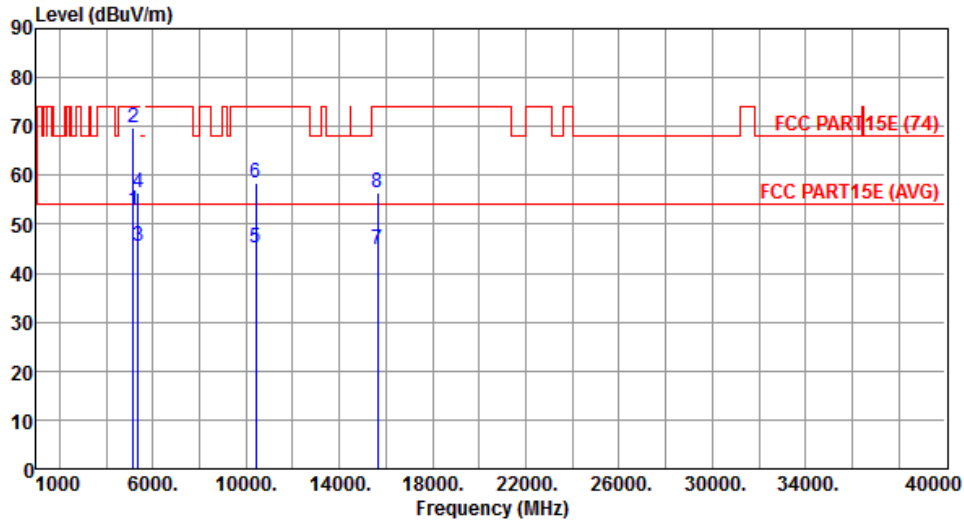

| | Freq. MHz | Emission level dBuV/m | Limit dBuV/m | Margin dB | SA reading dBuV | Factor dB | Remark | ANT High cm | Turn Table deg |
|---|--------------|-----------------------------|-----------------|--------------|-----------------------|--------------|---------|-------------------|----------------------|
| 1 | 5150.00 | 52.87 | 54.00 | -1.13 | 47.16 | 5.71 | Average | --- | --- |
| 2 | 5150.00 | 69.74 | 74.00 | -4.26 | 64.03 | 5.71 | Peak | --- | --- |
| 3 | 5350.00 | 45.37 | 54.00 | -8.63 | 39.38 | 5.99 | Average | --- | --- |
| 4 | 5350.00 | 56.45 | 74.00 | -17.55 | 50.46 | 5.99 | Peak | --- | --- |
| 5 | 10420.00 | 45.18 | 54.00 | -8.82 | 30.64 | 14.54 | Average | --- | --- |
| 6 | 10420.00 | 58.46 | 74.00 | -15.54 | 43.92 | 14.54 | Peak | --- | --- |
| 7 | 15630.00 | 44.72 | 54.00 | -9.28 | 29.61 | 15.11 | Average | --- | --- |
| 8 | 15630.00 | 56.56 | 74.00 | -17.44 | 41.45 | 15.11 | Peak | --- | --- |

Note 1: Emission Level (dBuV/m) = SA Reading (dBuV/m) + Factor* (dB)

*Factor includes antenna factor , cable loss and amplifier gain

Note 2: Margin (dB) = Emission level (dBuV/m) – Limit (dBuV/m).

3.6 Frequency Stability

3.6.1 Limit of Frequency Stability

Manufacturers of U-NII devices are responsible for ensuring frequency stability such that an emission is maintained within the band of operation under all conditions of normal operation as specified in the user's manual.

3.6.2 Test Procedures

1. The EUT is installed in an environment test chamber with external power source.
2. Set the chamber to operate at 50 centigrade and external power source to output at nominal voltage of EUT.
3. A sufficient stabilization period at each temperature is used prior to each frequency measurement.
4. When temperature is stabled, measure the frequency stability.
5. The test shall be performed under -30 to 50 centigrade and 85 to 115 percent of the nominal voltage. Change setting of chamber and external power source to complete all conditions.

3.6.3 Test Setup

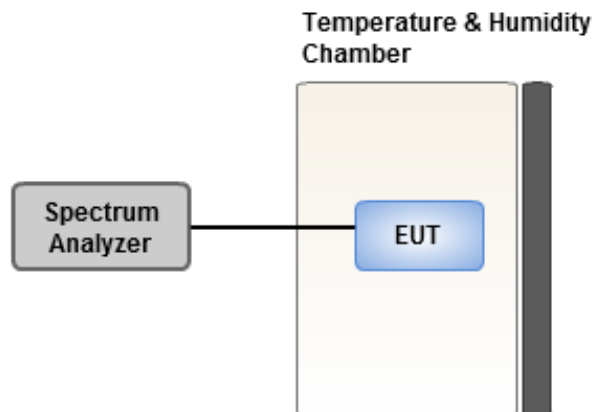

3.6.4 Test Result of Frequency Stability

| Frequency: 5200 MHz | Frequency Drift (ppm) | | | |
|------------------------|-----------------------|-----------------|-----------|-----------------|
| | 0 minute | 2 minutes | 5 minutes | 10 minutes |
| T20°CVmax | 0.18 | -0.14 | 0.54 | 0.92 |
| T20°CVmin | 3.87 | 3.46 | 3.84 | 3.97 |
| T50°CVnom | 4.36 | 4.47 | 4.41 | 5.08 |
| T40°CVnom | -2.11 | -2.11 | -1.84 | -1.71 |
| T30°CVnom | 0.34 | 0.37 | 0.18 | 0.67 |
| T20°CVnom | 0.22 | 0.51 | 0.55 | 0.66 |
| T10°CVnom | -0.33 | -0.35 | -0.03 | -0.28 |
| T0°CVnom | -0.11 | -0.09 | 0.33 | 0.15 |
| T-10°CVnom | -0.75 | -0.49 | -0.76 | -0.40 |
| T-20°CVnom | -0.69 | -0.04 | -0.80 | -0.80 |
| T-30°CVnom | -0.54 | -0.44 | -0.48 | -0.02 |
| Vnom [Vac]: 120 | | Vmax [Vac]: 138 | | Vmin [Vac]: 102 |
| Tnom [°C]: 20 | | Tmax [°C]: 50 | | Tmin [°C]: -30 |

4 Test laboratory information

Established in 2012, ICC provides foremost EMC & RF Testing and advisory consultation services by our skilled engineers and technicians. Our services employ a wide variety of advanced edge test equipment and one of the widest certification extents in the business.

International Certification Corp, it is our definitive objective is to institute long term, trust-based associations with our clients. The expectation we set up with our clients is based on outstanding service, practical expertise and devotion to a certified value structure. Our passion is to grant our clients with best EMC / RF services by oriented knowledgeable and accommodating staff.

Our Test sites are located at Linkou District and Kwei Shan Hsiang. Location map can be found on our website <http://www.icertifi.com.tw>.

Linkou

Tel: 886-2-2601-1640

No. 30-2, Ding Fwu Tsuen, Lin
Kou District, New Taipei City,
Taiwan, R.O.C.

Kwei Shan

Tel: 886-3-271-8666

No. 3-1, Lane 6, Wen San 3rd St.,
Kwei Shan Hsiang, Tao Yuan
Hsien 333, Taiwan, R.O.C.

Kwei Shan Site II

Tel: 886-3-271-8640

No. 14-1, Lane 19, Wen San 3rd
St., Kwei Shan Hsiang, Tao Yuan
Hsien 333, Taiwan, R.O.C.

If you have any suggestion, please feel free to contact us as below information

Tel: 886-3-271-8666

Fax: 886-3-318-0155

Email: ICC_Service@icertifi.com.tw

==END==