

| REV | DESCRIPTION OF REVISION     | ENG APPD   | DATE    |
|-----|-----------------------------|------------|---------|
| 01  | INITIAL DOCUMENT CREATION   | R HU       | 10MAR14 |
| 02  | CHANGED FC ID, PRODUCT NAME | M HUMPHREY | 11AUG14 |

**NETGEAR**® Outdoor High Power Wireless N Access Point **WND930**  
 Powered by PoE: 2x 802.3af or 1x 802.3at power

**DEFAULT ACCESS**  
 IP: http://192.168.0.100  
 User Name: admin  
 password: password

FC CMIIT ID: 2014AJ3486  
 FCC ID: PY314200281  
 IC: 4054A-14200281

This device complies with Part 15 of the FCC Rules. Operation is subject to the following two conditions: (1) this device may not cause harmful interference, and (2) this device must accept any interference received, including interference that may cause undesired operation.

10 R-NZ EAC CE

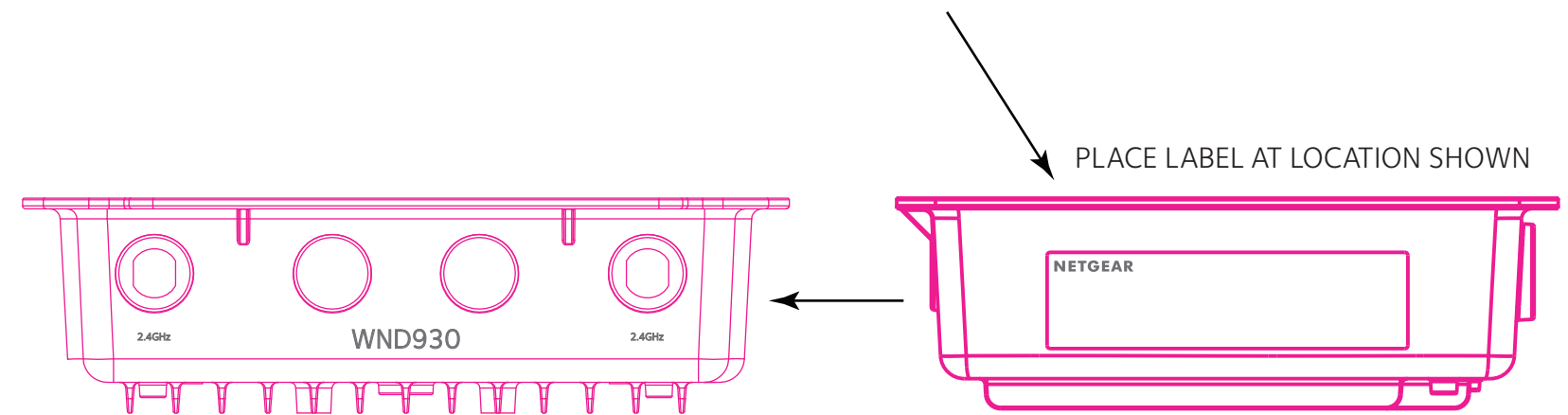

SSID:   
 SERIAL:   
 MAC:

Made in China 272-12205-01



**NOTE:**

1. REFER TO NETGEAR SPEC. DOC-00093 FOR COLOR TOLERANCES.
2. INK COLOR IS SHOWN TO THE RIGHT.
3. PART OUTLINE IS MAGENTA COLOR AND DOES NOT PRINT.
4. THE MATERIALS AND PROCESS USED TO FABRICATE THIS PART ARE TO BE CONSISTENT WITH THE EU DIRECTIVE 2002/95/EC, RESTRICTION OF HAZARDOUS SUBSTANCES IN ELECTRICAL AND ELECTRONIC EQUIPMENT (RoHS). THE FINISHED PART TO BE ACCOMPANIED BY A SIGNED CERTIFICATE OF COMPLIANCE TO DIRECTIVE 2002/95/EC.

 White  
 Pantone Cool Grey 11C

|                       |   |                     |            |
|-----------------------|---|---------------------|------------|
| AUTHOR:<br>M HUMPHREY | TITLE:<br>AW, WND930, PLBL  | <b>NETGEAR</b>      |            |
| SHEET:<br>1 of 1      | THIS DOCUMENT AND THE DATA DISCLOSED HEREIN OR WHEREWITH IS NOT TO BE REPRODUCED, USED OR DISCLOSED IN WHOLE OR IN PART TO ANYONE WITHOUT THE PERMISSION OF NETGEAR, INC. | P/N:<br>AW-12884-01 | REV:<br>02 |

# FCC LABEL LOCATION

The label will be permanently affixed at a conspicuous location on the device.

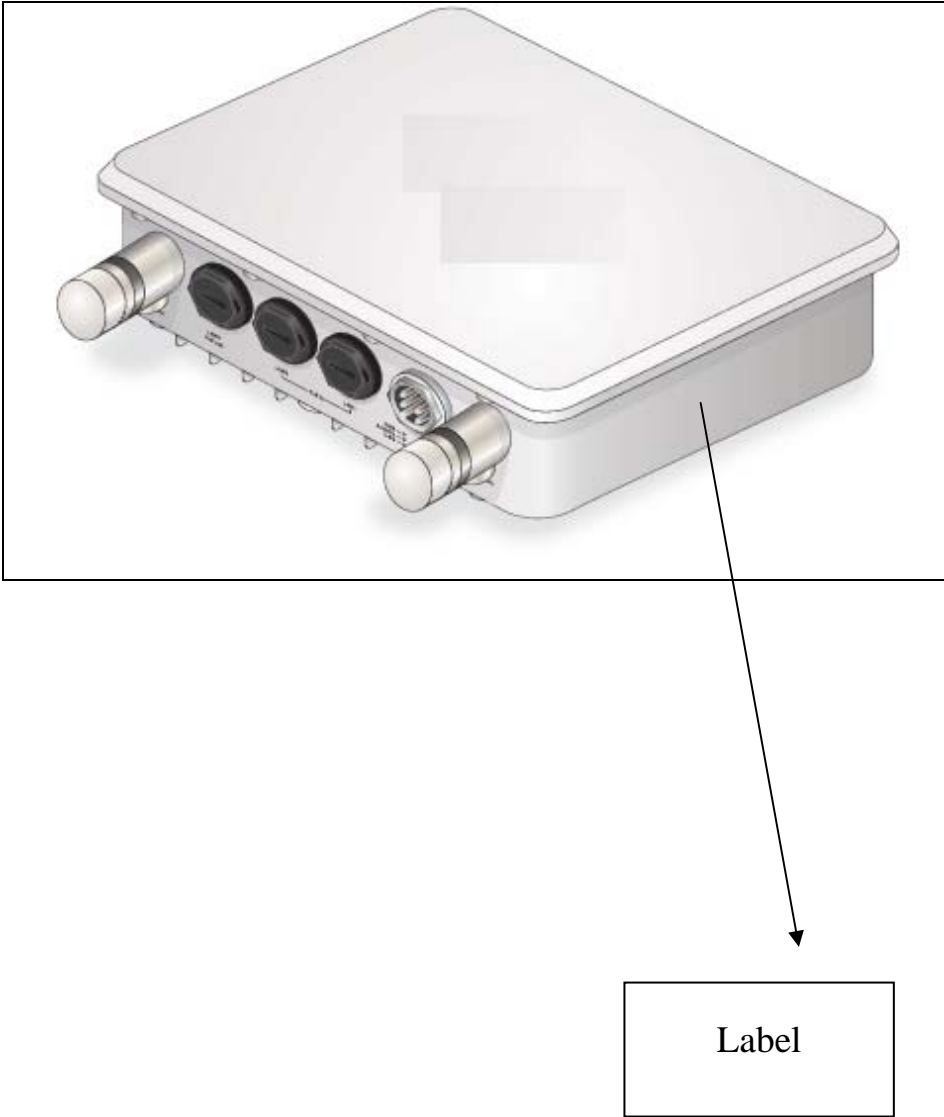

(Fig. 1) FCC ID: PY314200281