

## FCC Test Report

**Report No.:** RF140710C17D-1

**FCC ID:** PY314200260

**Test Model:** C6300BD

**Received Date:** July 14, 2015

**Test Date:** Aug. 17 to 19, 2015

**Issued Date:** Sep. 10, 2015

**Applicant:** NETGEAR, INC.

**Address:** 350 East Plumeria Drive San Jose, CA 95134

**Issued By:** Bureau Veritas Consumer Products Services (H.K.) Ltd., Taoyuan Branch  
Hsin Chu Laboratory

**Lab Address:** No. 81-1, Lu Liao Keng, 9th Ling, Wu Lung Tsuen, Chiung Lin Hsiang, Hsin  
Chu Hsien 307, Taiwan R.O.C.

**Test Location (1):** No. 81-1, Lu Liao Keng, 9th Ling, Wu Lung Tsuen, Chiung Lin Hsiang, Hsin  
Chu Hsien 307, Taiwan R.O.C.

**Test Location (2):** No. 49, Ln. 206, Wende Rd., Shangshan Tsuen, Chiung Lin Hsiang, Hsin  
Chu Hsien 307, Taiwan R.O.C.

**Test Location (3):** E-2, No.1, Li Hsin 1st Road, Hsinchu Science Park, Hsinchu City 300,  
Taiwan R.O.C.



This report is for your exclusive use. Any copying or replication of this report to or for any other person or entity, or use of our name or trademark, is permitted only with our prior written permission. This report sets forth our findings solely with respect to the test samples identified herein. The results set forth in this report are not indicative or representative of the quality or characteristics of the lot from which a test sample was taken or any similar or identical product unless specifically and expressly noted. Our report includes all of the tests requested by you and the results thereof based upon the information that you provided to us. You have 60 days from date of issuance of this report to notify us of any material error or omission caused by our negligence, provided, however, that such notice shall be in writing and shall specifically address the issue you wish to raise. A failure to raise such issue within the prescribed time shall constitute your unqualified acceptance of the completeness of this report, the tests conducted and the correctness of the report contents. Unless specific mention, the uncertainty of measurement has been explicitly taken into account to declare the compliance or non-compliance to the specification. The report must not be used by the client to claim product certification, approval, or endorsement by TAF or any government agencies.

## Table of Contents

|   |           |
|---|-----------|
| <b>Release Control Record</b> .....                             | <b>4</b>  |
| <b>1 Certificate of Conformity</b> .....                        | <b>5</b>  |
| <b>2 Summary of Test Results</b> .....                          | <b>6</b>  |
| 2.1 Measurement Uncertainty.....                                | 6         |
| 2.2 Modification Record.....                                    | 6         |
| <b>3 General Information</b> .....                              | <b>7</b>  |
| 3.1 General Description of EUT.....                             | 7         |
| 3.2 Description of Test Modes.....                              | 10        |
| 3.2.1 Test Mode Applicability and Tested Channel Detail.....    | 11        |
| 3.3 Duty Cycle of Test Signal.....                              | 13        |
| 3.4 Description of Support Units.....                           | 14        |
| 3.4.1 Configuration of System under Test.....                   | 15        |
| 3.5 General Description of Applied Standard.....                | 16        |
| <b>4 Test Types and Results</b> .....                           | <b>17</b> |
| 4.1 Radiated Emission and Bandedge Measurement.....             | 17        |
| 4.1.1 Limits of Radiated Emission and Bandedge Measurement..... | 17        |
| 4.1.2 Test Instruments.....                                     | 18        |
| 4.1.3 Test Procedure.....                                       | 19        |
| 4.1.4 Deviation from Test Standard.....                         | 19        |
| 4.1.5 Test Setup.....   | 20        |
| 4.1.6 EUT Operating Condition.....                              | 20        |
| 4.1.7 Test Results.....   | 21        |
| 4.2 Transmit Power Measurement.....                             | 31        |
| 4.2.1 Limits of Transmit Power Measurement.....                 | 31        |
| 4.2.2 Test Setup.....   | 31        |
| 4.2.3 Test Instruments.....                                     | 31        |
| 4.2.4 Test Procedure.....                                       | 31        |
| 4.2.5 Deviation from Test Standard.....                         | 31        |
| 4.2.6 EUT Operating Condition.....                              | 31        |
| 4.2.7 Test Result.....  | 32        |
| 4.3 Peak Power Spectral Density Measurement.....                | 33        |
| 4.3.1 Limits of Peak Power Spectral Density Measurement.....    | 33        |
| 4.3.2 Test Setup.....   | 33        |
| 4.3.3 Test Instruments.....                                     | 33        |
| 4.3.4 Test Procedure.....                                       | 33        |
| 4.3.5 Deviation from Test Standard.....                         | 34        |
| 4.3.6 EUT Operating Condition.....                              | 34        |
| 4.3.7 Test Results.....   | 35        |
| 4.4 Frequency Stability Measurement.....                        | 38        |
| 4.4.1 Limits of Frequency Stability Measurement.....            | 38        |
| 4.4.2 Test Setup.....   | 38        |
| 4.4.3 Test Instruments.....                                     | 38        |
| 4.4.4 Test Procedure.....                                       | 38        |
| 4.4.5 Deviation from Test Standard.....                         | 38        |
| 4.4.6 EUT Operating Condition.....                              | 38        |
| 4.4.7 Test Results.....   | 39        |
| 4.5 6dB Bandwidth Measurement.....                              | 40        |
| 4.5.1 Limits of 6dB Bandwidth Measurement.....                  | 40        |
| 4.5.2 Test Setup.....   | 40        |
| 4.5.3 Test Instruments.....                                     | 40        |
| 4.5.4 Test Procedure.....                                       | 40        |
| 4.5.5 Deviation from Test Standard.....                         | 40        |
| 4.5.6 EUT Operating Condition.....                              | 40        |



4.5.7 Test Results ..... 41

**5 Pictures of Test Arrangements..... 43**

**Appendix – Information on the Testing Laboratories ..... 44**



### Release Control Record

| Issue No.      | Description       | Date Issued   |
|----------------|-------------------|---------------|
| RF140710C17D-1 | Original release. | Sep. 10, 2015 |



**1 Certificate of Conformity**

**Product:** Wireless Cable Data Gateway  
**Brand:** NETGEAR  
**Test Model:** C6300BD  
**Sample Status:** ENGINEERING SAMPLE  
**Applicant:** NETGEAR, INC.  
**Test Date:** Aug. 17 to 19, 2015  
**Standard:** 47 CFR FCC Part 15, Subpart E (Section 15.407)  
ANSI C63.10: 2013

The above equipment has been tested by **Bureau Veritas Consumer Products Services (H.K.) Ltd., Taoyuan Branch**, and found compliance with the requirement of the above standards. The test record, data evaluation & Equipment Under Test (EUT) configurations represented herein are true and accurate accounts of the measurements of the sample's EMC characteristics under the conditions specified in this report.

**Prepared by :** Midoli Peng, **Date:** Sep. 10, 2015  
Midoli Peng / Specialist

**Approved by :** May Chen, **Date:** Sep. 10, 2015  
May Chen / Manager

## 2 Summary of Test Results

| 47 CFR FCC Part 15, Subpart E (SECTION 15.407) |  |        |  |
|--|--|--------|--|
| FCC Clause                                     | Test Item                                  | Result | Remarks  |
| 15.407(b)<br>(1/2/3/4/6)                       | Radiated Emissions & Band Edge Measurement | PASS   | Meet the requirement of limit.<br>Minimum passing margin is -0.1dB at 5863.00MHz, 5904.00MHz, 5725.00MHz, 5711.00MHz & 5904.00MHz. |
| 15.407(a)(1/2 /3)                              | Max Average Transmit Power                 | PASS   | Meet the requirement of limit.   |
| 15.407(a)(1/2 /3)                              | Peak Power Spectral Density                | PASS   | Meet the requirement of limit.   |
| 15.407(e)                                      | 6dB bandwidth                              | PASS   | Meet the requirement of limit.<br>(U-NII-3 Band only)  |
| 15.407(g)                                      | Frequency Stability                        | PASS   | Meet the requirement of limit.   |
| 15.203   | Antenna Requirement                        | PASS   | Antenna connector is I-PEX not a standard connector.   |

Note: This report is prepared for FCC Class II change. (U-NII-3 band: upgrade the standard to section 15.407)

### 2.1 Measurement Uncertainty

Where relevant, the following measurement uncertainty levels have been estimated for tests performed on the EUT as specified in CISPR 16-4-2:

| Measurement                    | Frequency     | Expanded Uncertainty (k=2) (±) |
|--------------------------------|---------------|--------------------------------|
| Radiated Emissions up to 1 GHz | 30MHz ~ 1GHz  | 5.37 dB                        |
| Radiated Emissions above 1 GHz | 1GHz ~ 6GHz   | 3.65 dB                        |
|                                | 6GHz ~ 18GHz  | 3.88 dB                        |
|                                | 18GHz ~ 40GHz | 4.11 dB                        |

### 2.2 Modification Record

There were no modifications required for compliance.

### 3 General Information

#### 3.1 General Description of EUT

|                       |  |
|-----------------------|--|
| Product               | Wireless Cable Data Gateway  |
| Brand                 | NETGEAR  |
| Test Model            | C6300BD  |
| Status of EUT         | ENGINEERING SAMPLE   |
| Power Supply Rating   | DC 12V from power adapter  |
| Modulation Type       | CCK, DQPSK, DBPSK for DSSS<br>64QAM, 16QAM, QPSK, BPSK for OFDM<br>256QAM for OFDM in 11ac mode only                                       |
| Modulation Technology | DSSS, OFDM   |
| Transfer Rate         | 802.11b: up to 11Mbps<br>802.11a / g: up to 54Mbps<br>802.11n: up to 450Mbps<br>802.11ac: up to 1300Mbps                                   |
| Operating Frequency   | <b>For 15.407</b><br>5.18 ~ 5.24GHz, 5.26 ~ 5.32GHz, 5.5~5.7GHz 5.745 ~ 5.825GHz   |
|                       | <b>For 15.247</b><br>2.412 ~ 2.462GHz  |
| Number of Channel     | <b>For 15.407</b><br>24 for 802.11a, 802.11n (HT20), 802.11ac (VHT20)<br>11 for 802.11n (HT40), 802.11ac (VHT40)<br>5 for 802.11ac (VHT80) |
|                       | <b>For 15.247</b><br>11 for 802.11b, 802.11g, 802.11n (HT20)<br>7 for 802.11n (HT40)   |
| Output Power          | <b>For 15.407 (U-NII-3 band)</b><br><b>CDD Mode:</b><br>802.11a: 243.142mW   |
|                       | <b>Beamforming Mode:</b><br>802.11ac (VHT20): 218.617mW  |
|                       | 802.11ac (VHT40): 172.345mW  |
|                       | 802.11ac (VHT80): 98.203mW   |
| Antenna Type          | Refer to Note  |
| Antenna Connector     | Refer to Note  |
| Accessory Device      | Adapter x 1  |
| Data Cable Supplied   | NA   |

**Note:**

1. This report is prepared for FCC class II change. The differences between them are as below information:
  - ◆ Upgrade the standard to section 15.407 under new rule for U-NII-3 band.
2. According to above conditions, all test items of U-NII-3 band test item need to be performed, except for AC power conducted emission test item. And all data was verified to meet the requirements.
3. The antennas provided to the EUT, please refer to the following table:

| For 2.4GHz used |                     |             |              |              |                    |                |
|-----------------|---------------------|-------------|--------------|--------------|--------------------|----------------|
| Ant. No.        | Transmitter Circuit | Brand       | Model        | Antenna Type | Antenna Gain (dBi) | Connector type |
| 1               | Chain (0)           | Master Wave | 98P92UIPF030 | PCB          | 2                  | I-PEX          |
| 2               | Chain (1)           |             | 98P92UIPF031 |              | 2                  |                |
| 3               | Chain (2)           |             | 98P92UIPF033 |              | 2                  |                |
| For 5GHz used   |                     |             |              |              |                    |                |
| Ant. No.        | Transmitter Circuit | Brand       | Model        | Antenna Type | Antenna Gain (dBi) | Connector type |
| 4               | Chain (0)           | Master Wave | 98P92UIPF033 | PCB          | 2                  | I-PEX          |
| 5               | Chain (1)           |             | 98P92UIPF034 |              | 2                  |                |
| 6               | Chain (2)           |             | 98P92UIPF034 |              | 2                  |                |

4. The EUT could be supplied with a power adapter and following two different models could be chosen as following table:

| No. | Brand   | Model No. | P/N No.      | Spec.  |
|-----|---------|-----------|--------------|--|
| 1   | Netgear | 2AAF042F  | 332-10618-01 | AC I/P: 100-240V, 1.5A, 50/60Hz<br>DC O/P: 12V, 3.5A<br>DC output cable (Unshielded, 1.8m) |
| 2   | Netgear | AD898F20  | 332-10613-01 | AC I/P: 100-240V, 1A, 50/60Hz<br>DC O/P: 12V, 3.5A<br>DC output cable (Unshielded, 1.8m)   |



5. The EUT incorporates a MIMO function.

| <b>2.4GHz Band</b>      |                        |                             |     |
|-------------------------|------------------------|-----------------------------|-----|
| <b>MODULATION MODE</b>  | <b>DATA RATE (MCS)</b> | <b>TX &amp; RX FUNCTION</b> |     |
| <b>802.11b</b>          | 1 ~ 11Mbps             | 3TX                         | 3RX |
| <b>802.11g</b>          | 6 ~ 54Mbps             | 3TX                         | 3RX |
| <b>802.11n (HT20)</b>   | MCS 0~7                | 3TX                         | 3RX |
|                         | MCS 8~15               | 3TX                         | 3RX |
|                         | MCS 16~23              | 3TX                         | 3RX |
| <b>802.11n (HT40)</b>   | MCS 0~7                | 3TX                         | 3RX |
|                         | MCS 8~15               | 3TX                         | 3RX |
|                         | MCS 16~23              | 3TX                         | 3RX |
| <b>5GHz Band</b>        |                        |                             |     |
| <b>MODULATION MODE</b>  | <b>DATA RATE (MCS)</b> | <b>TX &amp; RX FUNCTION</b> |     |
| <b>802.11a</b>          | 6 ~ 54Mbps             | 3TX                         | 3RX |
| <b>802.11n (HT20)</b>   | MCS 0~7                | 3TX                         | 3RX |
|                         | MCS 8~15               | 3TX                         | 3RX |
|                         | MCS 16~23              | 3TX                         | 3RX |
| <b>802.11n (HT40)</b>   | MCS 0~7                | 3TX                         | 3RX |
|                         | MCS 8~15               | 3TX                         | 3RX |
|                         | MCS 16~23              | 3TX                         | 3RX |
| <b>802.11ac (VHT20)</b> | MCS0~8 Nss= 1          | 3TX                         | 3RX |
|                         | MCS0~8 Nss= 2          | 3TX                         | 3RX |
|                         | MCS0~9 Nss= 3          | 3TX                         | 3RX |
| <b>802.11ac (VHT40)</b> | MCS0~9 Nss= 1          | 3TX                         | 3RX |
|                         | MCS0~9 Nss= 2          | 3TX                         | 3RX |
|                         | MCS0~9 Nss= 3          | 3TX                         | 3RX |
| <b>802.11ac (VHT80)</b> | MCS0~9 Nss= 1          | 3TX                         | 3RX |
|                         | MCS0~9 Nss= 2          | 3TX                         | 3RX |
|                         | MCS0~9 Nss= 3          | 3TX                         | 3RX |

Note: The modulation and bandwidth are similar for 802.11n mode for 20MHz (40MHz) and 802.11ac mode for 20MHz (40MHz), therefore investigated worst case to representative mode in test report. (Final test mode refer section 3.2.1)

6. The emission of the simultaneous operation (2.4GHz & 5GHz) has been evaluated and no non-compliance was found.
7. The above EUT information was declared by the manufacturer and for more detailed features description, please refer to the manufacturer's specifications or User's Manual.

### 3.2 Description of Test Modes

#### FOR 5745 ~ 5825MHz:

5 channels are provided for 802.11a, 802.11n (HT20), 802.11ac (VHT20):

| Channel | Frequency | Channel | Frequency |
|---------|-----------|---------|-----------|
| 149     | 5745MHz   | 161     | 5805MHz   |
| 153     | 5765MHz   | 165     | 5825MHz   |
| 157     | 5785MHz   |         |           |

2 channels are provided for 802.11n (HT40), 802.11ac (VHT40):

| Channel | Frequency | Channel | Frequency |
|---------|-----------|---------|-----------|
| 151     | 5755MHz   | 159     | 5795MHz   |

1 channel is provided for 802.11ac (VHT80):

| Channel | Frequency |
|---------|-----------|
| 155     | 5775MHz   |

### 3.2.1 Test Mode Applicability and Tested Channel Detail

| EUT CONFIGURE MODE | APPLICABLE TO |       |     |      | DESCRIPTION                    |
|--------------------|---------------|-------|-----|------|--------------------------------|
|                    | RE≥1G         | RE<1G | PLC | APCM |                                |
| -                  | √             | √     | -   | √    | With adapter 1 / EUT (Y-plane) |

Where **RE≥1G**: Radiated Emission above 1GHz      **RE<1G**: Radiated Emission below 1GHz  
**PLC**: Power Line Conducted Emission      **APCM**: Antenna Port Conducted Measurement

**NOTE:**

1. The test mode was reference to the worst case in the original test report.
2. "-" means no effect.

**Radiated Emission Test (Above 1GHz):**

- Pre-Scan has been conducted to determine the worst-case mode from all possible combinations between available modulations, data rates and antenna ports (if EUT with antenna diversity architecture).
- Following channel(s) was (were) selected for the final test as listed below.

| CDD Mode         |                  |                   |                |                       |                 |                  |
|------------------|------------------|-------------------|----------------|-----------------------|-----------------|------------------|
| MODE             | FREQ. BAND (MHz) | AVAILABLE CHANNEL | TESTED CHANNEL | MODULATION TECHNOLOGY | MODULATION TYPE | DATA RATE (Mbps) |
| 802.11a          | 5745-5825        | 149 to 165        | 149, 157, 165  | OFDM                  | BPSK            | 6                |
| Beamforming Mode |                  |                   |                |                       |                 |                  |
| MODE             | FREQ. BAND (MHz) | AVAILABLE CHANNEL | TESTED CHANNEL | MODULATION TECHNOLOGY | MODULATION TYPE | DATA RATE (Mbps) |
| 802.11ac (VHT20) | 5745-5825        | 149 to 165        | 149, 157, 165  | OFDM                  | BPSK            | 6.5              |
| 802.11ac (VHT40) |                  | 151 to 159        | 151, 159       | OFDM                  | BPSK            | 13.5             |
| 802.11ac (VHT80) |                  | 155               | 155            | OFDM                  | BPSK            | 29.3             |

**Radiated Emission Test (Below 1GHz):**

- Pre-Scan has been conducted to determine the worst-case mode from all possible combinations between available modulations, data rates and antenna ports (if EUT with antenna diversity architecture).
- Following channel(s) was (were) selected for the final test as listed below.

| Beamforming Mode |                  |                   |                |                       |                 |                  |
|------------------|------------------|-------------------|----------------|-----------------------|-----------------|------------------|
| MODE             | FREQ. BAND (MHz) | AVAILABLE CHANNEL | TESTED CHANNEL | MODULATION TECHNOLOGY | MODULATION TYPE | DATA RATE (Mbps) |
| 802.11ac (VHT20) | 5745-5825        | 149 to 165        | 149            | OFDM                  | BPSK            | 6.5              |

**Antenna Port Conducted Measurement:**

- This item includes all test value of each mode, but only includes spectrum plot of worst value of each mode.
- Pre-Scan has been conducted to determine the worst-case mode from all possible combinations between available modulations, data rates and antenna ports (if EUT with antenna diversity architecture).
- Following channel(s) was (were) selected for the final test as listed below.

| <b>CDD Mode</b>         |                  |                   |                |                       |                 |                  |
|-------------------------|------------------|-------------------|----------------|-----------------------|-----------------|------------------|
| MODE                    | FREQ. BAND (MHz) | AVAILABLE CHANNEL | TESTED CHANNEL | MODULATION TECHNOLOGY | MODULATION TYPE | DATA RATE (Mbps) |
| 802.11a                 | 5745-5825        | 149 to 165        | 149, 157, 165  | OFDM                  | BPSK            | 6                |
| <b>Beamforming Mode</b> |                  |                   |                |                       |                 |                  |
| MODE                    | FREQ. BAND (MHz) | AVAILABLE CHANNEL | TESTED CHANNEL | MODULATION TECHNOLOGY | MODULATION TYPE | DATA RATE (Mbps) |
| 802.11ac (VHT20)        | 5745-5825        | 149 to 165        | 149, 157, 165  | OFDM                  | BPSK            | 6.5              |
| 802.11ac (VHT40)        |                  | 151 to 159        | 151, 159       | OFDM                  | BPSK            | 13.5             |
| 802.11ac (VHT80)        |                  | 155               | 155            | OFDM                  | BPSK            | 29.3             |

**Test Condition:**

| APPLICABLE TO | ENVIRONMENTAL CONDITIONS | INPUT POWER  | TESTED BY     |
|---------------|--------------------------|--------------|---------------|
| RE≥1G         | 22deg. C, 67%RH          | 120Vac, 60Hz | Weiwei Lo     |
| RE<1G         | 22deg. C, 68%RH          | 120Vac, 60Hz | Andy Ho       |
| APCM          | 25deg. C, 60%RH          | 120Vac, 60Hz | Anderson Chen |

### 3.3 Duty Cycle of Test Signal

If duty cycle of test signal is  $\geq 98\%$ , duty factor is not required.

If duty cycle of test signal is  $< 98\%$ , duty factor shall be considered.

**802.11a:** Duty cycle =  $2.056 \text{ ms} / 2.08 \text{ ms} = 0.988$

**802.11ac (VHT20):** Duty cycle =  $1.914 \text{ ms} / 1.937 \text{ ms} = 0.988$

**802.11ac (VHT40):** Duty cycle =  $0.936 \text{ ms} / 0.973 \text{ ms} = 0.962$ , Duty factor =  $10 * \log(1/0.962) = 0.17$

**802.11ac (VHT80):** Duty cycle =  $0.454 \text{ ms} / 0.496 \text{ ms} = 0.915$ , Duty factor =  $10 * \log(1/0.915) = 0.38$

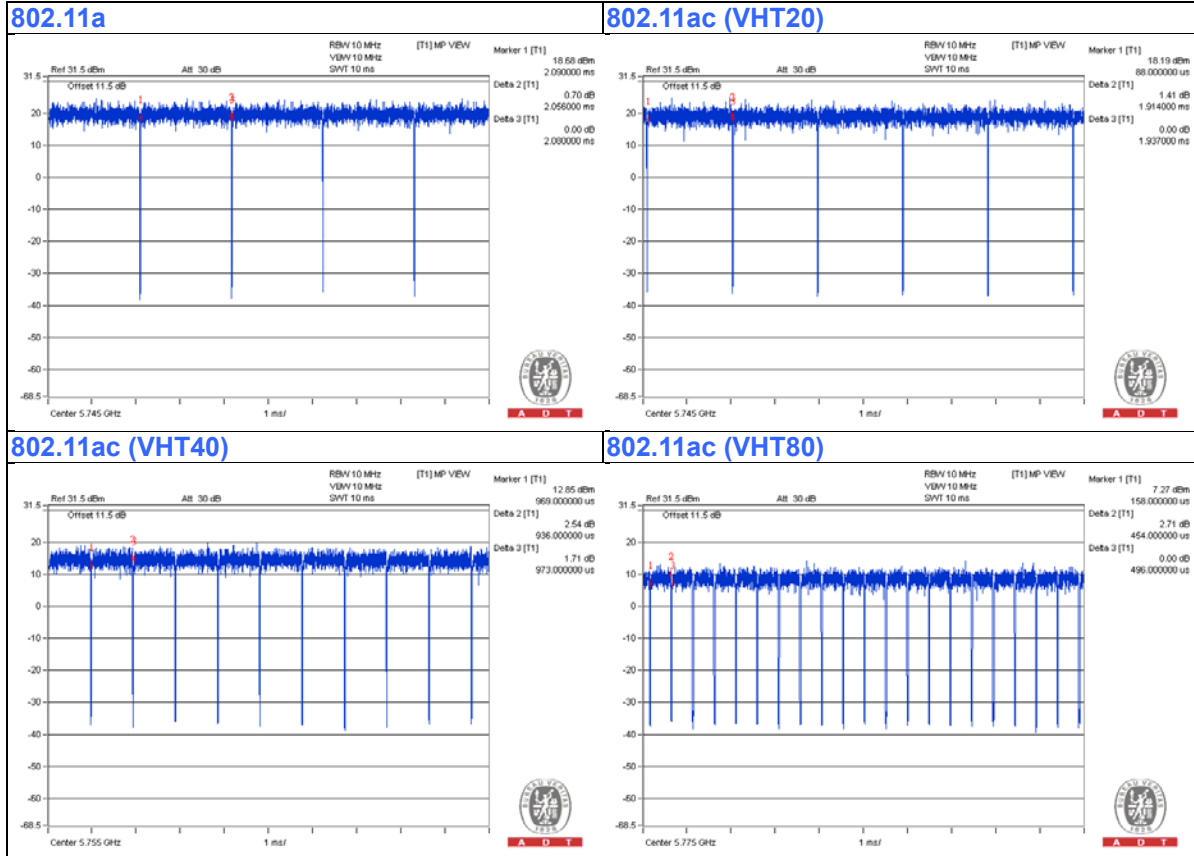

### 3.4 Description of Support Units

The EUT has been tested as an independent unit together with other necessary accessories or support units. The following support units or accessories were used to form a representative test configuration during the tests.

| No. | Product           | Brand | Model No.          | Serial No.    | FCC ID  | Remark          |
|-----|-------------------|-------|--------------------|---------------|---------|-----------------|
| A   | HDD               | WD    | WDBACW0010HBK-SESN | WCAZAL625787  | FCC DoC | Provided by Lab |
| B   | HUB               | ZyXEL | ES-116P            | S060H02000215 | FCC DoC | Provided by Lab |
| C   | NOTEBOOK COMPUTER | DELL  | PP32LA             | GSLB32S       | FCC DoC | Provided by Lab |

**NOTE:**

1. All power cords of the above support units are non-shielded (1.8 m).

| No. | Cable   | Qty. | Length (m) | Shielded (Yes/ No) | Cores (Number) | Remark             |
|-----|---------|------|------------|--------------------|----------------|--------------------|
| 1   | DC      | 1    | 1.8        | No                 | 0              | Supplied by client |
| 2   | USB 3.0 | 1    | 1          | Yes                | 0              | Provided by Lab    |
| 3   | RJ45    | 3    | 10         | No                 | 0              | Provided by Lab    |
| 4   | RJ45    | 1    | 10         | No                 | 0              | Provided by Lab    |
| 5   | Coaxial | 1    | 10         | No                 | 0              | Provided by Lab    |

### 3.4.1 Configuration of System under Test

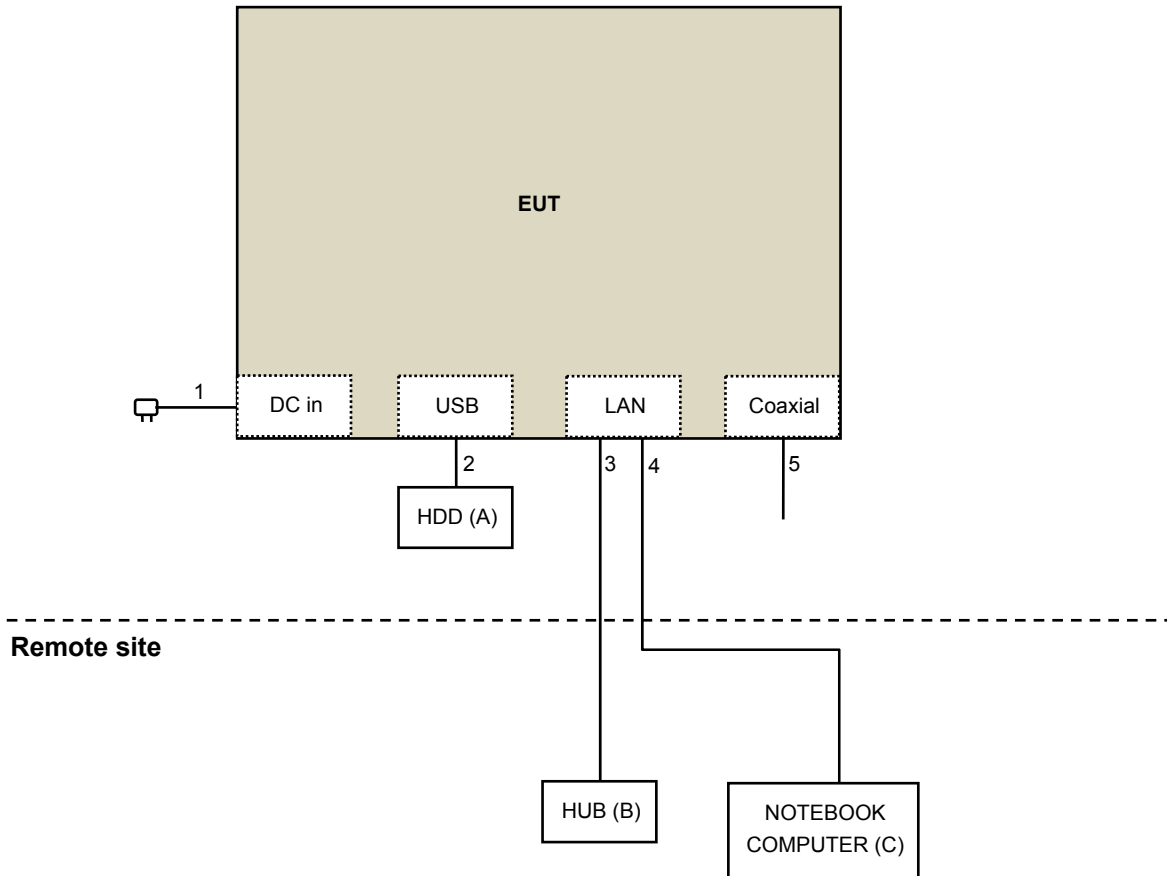

### 3.5 General Description of Applied Standard

The EUT is a RF Product. According to the specifications of the manufacturer, it must comply with the requirements of the following standards:

**FCC Part 15, Subpart E (15.407)**  
**789033 D02 General UNII Test Procedure New Rules v01**  
**662911 D01 Multiple Transmitter Output v02r01**  
ANSI C63.10-2013

All test items have been performed and recorded as per the above standards.



## 4 Test Types and Results

### 4.1 Radiated Emission and Bandedge Measurement

#### 4.1.1 Limits of Radiated Emission and Bandedge Measurement

Radiated emissions which fall in the restricted bands must comply with the radiated emission limits specified as below table.

| Frequencies (MHz) | Field Strength (microvolts/meter) | Measurement Distance (meters) |
|-------------------|-----------------------------------|-------------------------------|
| 0.009 ~ 0.490     | 2400/F(kHz)                       | 300                           |
| 0.490 ~ 1.705     | 24000/F(kHz)                      | 30                            |
| 1.705 ~ 30.0      | 30                                | 30                            |
| 30 ~ 88           | 100                               | 3                             |
| 88 ~ 216          | 150                               | 3                             |
| 216 ~ 960         | 200                               | 3                             |
| Above 960         | 500                               | 3                             |

**NOTE:**

1. The lower limit shall apply at the transition frequencies.
2. Emission level (dBuV/m) = 20 log Emission level (uV/m).
3. For frequencies above 1000MHz, the field strength limits are based on average detector, however, the peak field strength of any emission shall not exceed the maximum permitted average limits, specified above by more than 20dB under any condition of modulation.

LIMITS OF UNWANTED EMISSION OUT OF THE RESTRICTED BANDS

| APPLICABLE TO  | LIMIT  |  |
|--|--|--|
| 789033 D02 General UNII Test Procedure New Rules v01 | FIELD STRENGTH AT 3m   |  |
|  | PK:74 (dBuV/m)   | AV:54 (dBuV/m)   |
| APPLICABLE TO  | EIRP LIMIT   | EQUIVALENT FIELD STRENGTH AT 3m                                  |
| 15.407(b)(1)   | PK:-27 (dBm/MHz)   | PK:68.2(dBuV/m)  |
| 15.407(b)(2)   |  |  |
| 15.407(b)(3)   |  |  |
| 15.407(b)(4)   | PK:-27 (dBm/MHz) <sup>*1</sup><br>PK:-17 (dBm/MHz) <sup>*2</sup> | PK: 68.2(dBuV/m) <sup>*1</sup><br>PK:78.2 (dBuV/m) <sup>*2</sup> |

**NOTE:** <sup>\*1</sup> beyond 10MHz of the band edge <sup>\*2</sup> within 10 MHz of band edge

The following formula is used to convert the equipment isotropic radiated power (eirp) to field strength:

$$E = \frac{1000000\sqrt{30P}}{3} \mu\text{V/m, where P is the eirp (Watts).$$

**4.1.2 Test Instruments**

| <b>DESCRIPTION &amp; MANUFACTURER</b>           | <b>MODEL NO.</b>         | <b>SERIAL NO.</b>                         | <b>CALIBRATED DATE</b> | <b>CALIBRATED UNTIL</b> |
|---|--------------------------|---|------------------------|-------------------------|
| Test Receiver<br>Agilent                        | N9038A                   | MY51210105                                | July 24, 2015          | July 23, 2016           |
| Pre-Amplifier<br>Mini-Circuits                  | ZFL-1000VH2<br>B         | AMP-ZFL-03                                | Nov. 12, 2014          | Nov. 11, 2015           |
| Trilog Broadband Antenna<br>SCHWARZBECK         | VULB 9168                | 9168-360                                  | Feb. 06, 2015          | Feb. 05, 2016           |
| RF Cable  | 8D-FB                    | CHGCAB-001-1<br>CHGCAB-001-2              | Oct. 04, 2014          | Oct. 03, 2015           |
|   | RF-141                   | CHGCAB-004                                | Oct. 04, 2014          | Oct. 03, 2015           |
| Horn_Antenna<br>AISI                            | AIH.8018                 | 0000320091110                             | Feb. 09, 2015          | Feb. 08, 2016           |
| Pre-Amplifier<br>Agilent                        | 8449B                    | 3008A02578                                | June 23, 2015          | June 22, 2016           |
| RF Cable  | NA                       | 131205<br>131216<br>131217<br>SNMY23684/4 | Jan. 16, 2015          | Jan. 15, 2016           |
| Spectrum Analyzer<br>R&S                        | FSV40                    | 100964                                    | June 26, 2015          | June 25, 2016           |
| Pre-Amplifier<br>SPACEK LABS                    | SLKKa-48-6               | 9K16                                      | Dec. 12, 2014          | Dec. 11, 2015           |
| Horn_Antenna<br>SCHWARZBECK                     | BBHA 9170                | 9170-424                                  | Feb. 05, 2015          | Feb. 04, 2016           |
| RF Cable  | NA                       | 329751/4<br>RF104-204                     | Dec. 11, 2014          | Dec. 10, 2015           |
| Software  | ADT_Radiated<br>_V8.7.07 | NA  | NA                     | NA                      |
| Antenna Tower & Turn Table<br>CT                | NA                       | NA  | NA                     | NA                      |
| SPECTRUM ANALYZER<br>R&S                        | FSV 40                   | 100964                                    | June 26, 2015          | June 25, 2016           |
| Temperature & Humidity<br>Chamber<br>GIANTFORCE | GTH-150-40-S<br>P-AR     | MAA0812-008                               | Jan. 12, 2015          | Jan. 11, 2016           |
| Power Meter<br>Anritsu                          | ML2495A                  | 1014008                                   | Apr. 28, 2015          | Apr. 27, 2016           |
| Power Sensor<br>Anritsu                         | MA2411B                  | 0917122                                   | Apr. 28, 2015          | Apr. 27, 2016           |

**Note:**

1. The calibration interval of the above test instruments is 12 months and the calibrations are traceable to NML/ROC and NIST/USA.
2. The test was performed in 966 Chamber No. G.
3. The FCC Site Registration No. is 966073.
4. The VCCI Site Registration No. is G-137.
5. The CANADA Site Registration No. is IC 7450H-2.
7. Tested Date: Aug. 17 to 19, 2015

#### 4.1.3 Test Procedure

- a. The EUT was placed on the top of a rotating table 0.8 meters (for below 1GHz) / 1.5 meters (for above 1GHz) above the ground at 3 meter chamber room for test. The table was rotated 360 degrees to determine the position of the highest radiation.
- b. The EUT was set 3 meters away from the interference-receiving antenna, which was mounted on the top of a variable-height antenna tower.
- c. The height of antenna is varied from one meter to four meters above the ground to determine the maximum value of the field strength. Both horizontal and vertical polarizations of the antenna are set to make the measurement.
- d. For each suspected emission, the EUT was arranged to its worst case and then the antenna was tuned to heights from 1 meter to 4 meters and the rotatable table was turned from 0 degrees to 360 degrees to find the maximum reading.
- e. The test-receiver system was set to quasi-peak detect function and specified bandwidth with maximum hold mode when the test frequency is below 1 GHz.
- f. The test-receiver system was set to peak and average detect function and specified bandwidth with maximum hold mode when the test frequency is above 1 GHz. If the peak reading value also meets average limit, measurement with the average detector is unnecessary.

**Note:**

1. The resolution bandwidth and video bandwidth of test receiver/spectrum analyzer is 120kHz for Quasi-peak detection (QP) at frequency below 1GHz.
2. The resolution bandwidth of test receiver/spectrum analyzer is 1 MHz and the video bandwidth is 3 MHz for Peak detection (PK) at frequency above 1GHz.
3. The resolution bandwidth of test receiver/spectrum analyzer is 1MHz and the video bandwidth is 3MHz for RMS Average (Duty cycle < 98%) for Average detection (AV) at frequency above 1GHz, then the measurement results was added to a correction factor ( $10 \log(1/\text{duty cycle})$ ).
4. The resolution bandwidth of test receiver/spectrum analyzer is 1MHz and the video bandwidth is 10Hz (Duty cycle  $\geq 98\%$ ) for Average detection (AV) at frequency above 1GHz.
5. All modes of operation were investigated and the worst-case emissions are reported.

#### 4.1.4 Deviation from Test Standard

No deviation.

#### 4.1.5 Test Setup

##### <Frequency Range below 1GHz>

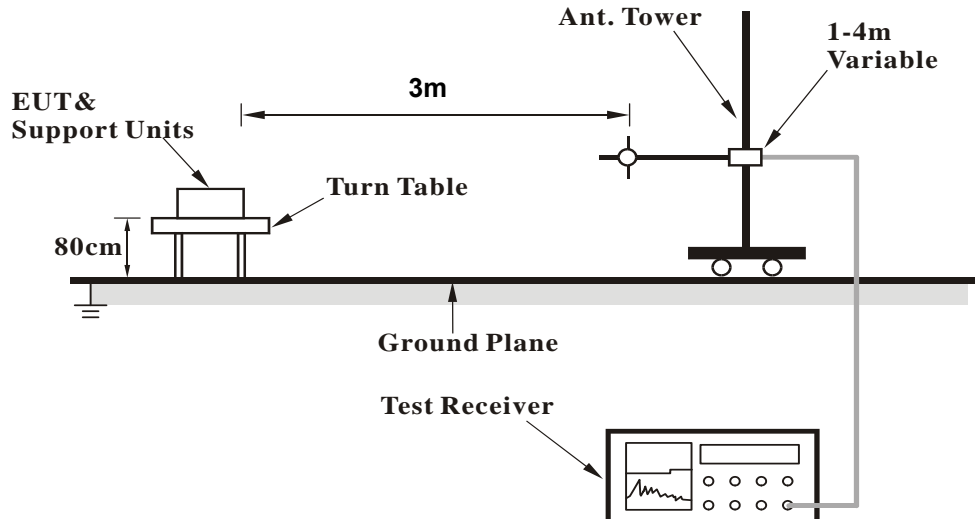

##### <Frequency Range above 1GHz>

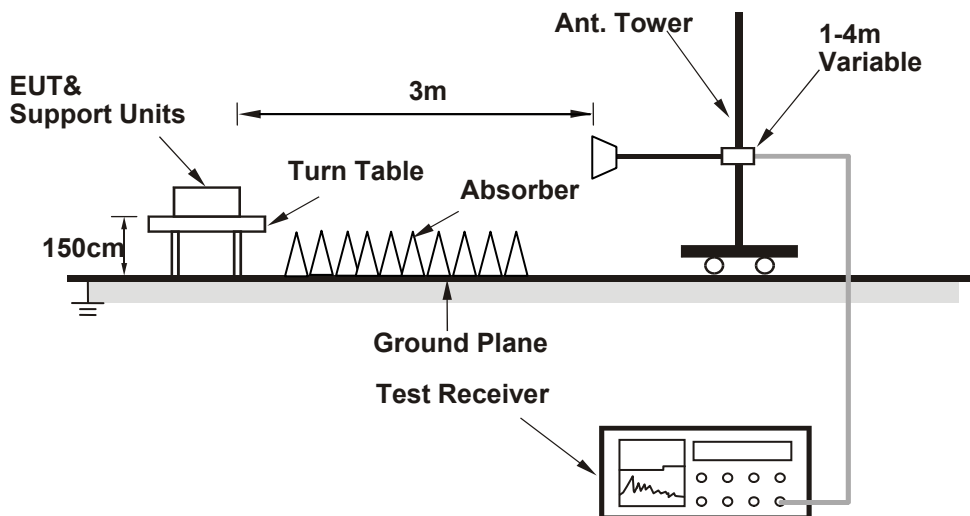

For the actual test configuration, please refer to the attached file (Test Setup Photo).

#### 4.1.6 EUT Operating Condition

1. Placed the EUT on testing table.
2. Prepared computer system (support unit C) to act as communication partner.
3. The communication partner ran test program "Mtool.exe[v2.0.1.1]" to enable EUT under transmission/receiving condition continuously.

#### 4.1.7 Test Results

#### Above 1GHz Data

#### CDD Mode

#### 802.11a

|                        |                |                              |              |
|------------------------|----------------|------------------------------|--------------|
| <b>CHANNEL</b>         | TX Channel 149 | <b>DETECTOR<br/>FUNCTION</b> | Peak (PK)    |
| <b>FREQUENCY RANGE</b> | 1GHz ~ 40GHz   |                              | Average (AV) |

#### ANTENNA POLARITY & TEST DISTANCE: HORIZONTAL AT 3 M

| NO. | FREQ.<br>(MHz) | EMISSION<br>LEVEL<br>(dBuV/m) | LIMIT<br>(dBuV/m) | MARGIN<br>(dB) | ANTENNA<br>HEIGHT<br>(m) | TABLE<br>ANGLE<br>(Degree) | RAW<br>VALUE<br>(dBuV) | CORRECTION<br>FACTOR<br>(dB/m) |
|-----|----------------|-------------------------------|-------------------|----------------|--------------------------|----------------------------|------------------------|--------------------------------|
| 1   | #5663.00       | 65.1 PK                       | 68.2              | -3.1           | 1.54 H                   | 278                        | 53.78                  | 11.32                          |
| 2   | #5715.00       | 68.1 PK                       | 74.0              | -5.9           | 1.51 H                   | 250                        | 56.57                  | 11.53                          |
| 3   | #5715.00       | 45.5 AV                       | 54.0              | -8.5           | 1.51 H                   | 250                        | 33.97                  | 11.53                          |
| 4   | #5725.00       | 75.5 PK                       | 78.2              | -2.7           | 1.51 H                   | 250                        | 63.95                  | 11.55                          |
| 5   | *5745.00       | 114.1 PK                      |                   |                | 1.51 H                   | 250                        | 102.47                 | 11.63                          |
| 6   | *5745.00       | 103.1 AV                      |                   |                | 1.51 H                   | 250                        | 91.47                  | 11.63                          |
| 7   | #5903.00       | 62.6 PK                       | 68.2              | -5.6           | 1.48 H                   | 301                        | 50.86                  | 11.74                          |
| 8   | 11490.00       | 53.5 PK                       | 74.0              | -20.5          | 1.42 H                   | 221                        | 36.20                  | 17.30                          |
| 9   | 11490.00       | 40.0 AV                       | 54.0              | -14.0          | 1.42 H                   | 221                        | 22.70                  | 17.30                          |
| 10  | #17235.00      | 58.9 PK                       | 74.0              | -15.1          | 1.58 H                   | 105                        | 32.09                  | 26.81                          |
| 11  | #17235.00      | 45.6 AV                       | 54.0              | -8.4           | 1.58 H                   | 105                        | 18.79                  | 26.81                          |

#### ANTENNA POLARITY & TEST DISTANCE: VERTICAL AT 3 M

| NO. | FREQ.<br>(MHz) | EMISSION<br>LEVEL<br>(dBuV/m) | LIMIT<br>(dBuV/m) | MARGIN<br>(dB) | ANTENNA<br>HEIGHT<br>(m) | TABLE<br>ANGLE<br>(Degree) | RAW<br>VALUE<br>(dBuV) | CORRECTION<br>FACTOR<br>(dB/m) |
|-----|----------------|-------------------------------|-------------------|----------------|--------------------------|----------------------------|------------------------|--------------------------------|
| 1   | #5663.00       | 67.4 PK                       | 68.2              | -0.8           | 1.98 V                   | 111                        | 56.08                  | 11.32                          |
| 2   | #5715.00       | 72.6 PK                       | 74.0              | -1.4           | 1.70 V                   | 122                        | 61.07                  | 11.53                          |
| 3   | #5715.00       | 50.5 AV                       | 54.0              | -3.5           | 1.70 V                   | 122                        | 38.97                  | 11.53                          |
| 4   | #5725.00       | 77.6 PK                       | 78.2              | -0.6           | 1.70 V                   | 122                        | 66.05                  | 11.55                          |
| 5   | *5745.00       | 117.8 PK                      |                   |                | 1.70 V                   | 122                        | 106.17                 | 11.63                          |
| 6   | *5745.00       | 107.3 AV                      |                   |                | 1.70 V                   | 122                        | 95.67                  | 11.63                          |
| 7   | #5903.00       | 65.8 PK                       | 68.2              | -2.4           | 1.83 V                   | 116                        | 54.06                  | 11.74                          |
| 8   | 11490.00       | 53.8 PK                       | 74.0              | -20.2          | 1.15 V                   | 247                        | 36.50                  | 17.30                          |
| 9   | 11490.00       | 40.5 AV                       | 54.0              | -13.5          | 1.15 V                   | 247                        | 23.20                  | 17.30                          |
| 10  | #17235.00      | 58.9 PK                       | 74.0              | -15.1          | 1.38 V                   | 235                        | 32.09                  | 26.81                          |
| 11  | #17235.00      | 46.2 AV                       | 54.0              | -7.8           | 1.38 V                   | 235                        | 19.39                  | 26.81                          |

#### REMARKS:

1. Emission Level(dBuV/m) = Raw Value(dBuV) + Correction Factor(dB/m)
2. Correction Factor(dB/m) = Antenna Factor(dB/m) + Cable Factor(dB) – Pre-Amplifier Factor(dB)
3. The other emission levels were very low against the limit.
4. Margin value = Emission Level – Limit value
5. " \* ": Fundamental frequency.
6. " # ": The radiated frequency is out of the restricted band.

|                        |                |                          |              |
|------------------------|----------------|--------------------------|--------------|
| <b>CHANNEL</b>         | TX Channel 157 | <b>DETECTOR FUNCTION</b> | Peak (PK)    |
| <b>FREQUENCY RANGE</b> | 1GHz ~ 40GHz   |                          | Average (AV) |

**ANTENNA POLARITY & TEST DISTANCE: HORIZONTAL AT 3 M**

| NO. | FREQ. (MHz) | EMISSION LEVEL (dBuV/m) | LIMIT (dBuV/m) | MARGIN (dB) | ANTENNA HEIGHT (m) | TABLE ANGLE (Degree) | RAW VALUE (dBuV) | CORRECTION FACTOR (dB/m) |
|-----|-------------|-------------------------|----------------|-------------|--------------------|----------------------|------------------|--------------------------|
| 1   | #5703.00    | 63.4 PK                 | 68.2           | -4.8        | 1.53 H             | 267                  | 51.92            | 11.48                    |
| 2   | *5785.00    | 114.2 PK                |                |             | 1.48 H             | 254                  | 102.46           | 11.74                    |
| 3   | *5785.00    | 103.2 AV                |                |             | 1.48 H             | 254                  | 91.46            | 11.74                    |
| 4   | #5850.00    | 58.7 PK                 | 78.2           | -19.5       | 1.48 H             | 254                  | 46.95            | 11.75                    |
| 5   | #5863.00    | 63.9 PK                 | 68.2           | -4.3        | 1.44 H             | 303                  | 52.15            | 11.75                    |
| 6   | 11570.00    | 53.6 PK                 | 74.0           | -20.4       | 1.42 H             | 225                  | 35.69            | 17.91                    |
| 7   | 11570.00    | 40.3 AV                 | 54.0           | -13.7       | 1.42 H             | 225                  | 22.39            | 17.91                    |
| 8   | #17355.00   | 59.0 PK                 | 74.0           | -15.0       | 1.58 H             | 99                   | 31.86            | 27.14                    |
| 9   | #17355.00   | 45.6 AV                 | 54.0           | -8.4        | 1.58 H             | 99                   | 18.46            | 27.14                    |

**ANTENNA POLARITY & TEST DISTANCE: VERTICAL AT 3 M**

| NO.      | FREQ. (MHz)     | EMISSION LEVEL (dBuV/m) | LIMIT (dBuV/m) | MARGIN (dB) | ANTENNA HEIGHT (m) | TABLE ANGLE (Degree) | RAW VALUE (dBuV) | CORRECTION FACTOR (dB/m) |
|----------|-----------------|-------------------------|----------------|-------------|--------------------|----------------------|------------------|--------------------------|
| 1        | #5703.00        | 67.2 PK                 | 68.2           | -1.0        | 1.92 V             | 116                  | 55.72            | 11.48                    |
| 2        | *5785.00        | 118.0 PK                |                |             | 1.74 V             | 124                  | 106.26           | 11.74                    |
| 3        | *5785.00        | 107.3 AV                |                |             | 1.74 V             | 124                  | 95.56            | 11.74                    |
| 4        | #5850.00        | 62.2 PK                 | 78.2           | -16.0       | 1.74 V             | 124                  | 50.45            | 11.75                    |
| <b>5</b> | <b>#5863.00</b> | <b>68.1 PK</b>          | <b>68.2</b>    | <b>-0.1</b> | <b>1.76 V</b>      | <b>117</b>           | <b>56.35</b>     | <b>11.75</b>             |
| 6        | 11570.00        | 54.2 PK                 | 74.0           | -19.8       | 1.16 V             | 251                  | 36.29            | 17.91                    |
| 7        | 11570.00        | 40.8 AV                 | 54.0           | -13.2       | 1.16 V             | 251                  | 22.89            | 17.91                    |
| 8        | #17355.00       | 58.5 PK                 | 74.0           | -15.5       | 1.37 V             | 233                  | 31.36            | 27.14                    |
| 9        | #17355.00       | 46.0 AV                 | 54.0           | -8.0        | 1.37 V             | 233                  | 18.86            | 27.14                    |

**REMARKS:**

1. Emission Level(dBuV/m) = Raw Value(dBuV) + Correction Factor(dB/m)
2. Correction Factor(dB/m) = Antenna Factor(dB/m) + Cable Factor(dB) – Pre-Amplifier Factor(dB)
3. The other emission levels were very low against the limit.
4. Margin value = Emission Level – Limit value
5. " \* ": Fundamental frequency.
6. " # ": The radiated frequency is out of the restricted band.

|                        |                |                          |              |
|------------------------|----------------|--------------------------|--------------|
| <b>CHANNEL</b>         | TX Channel 165 | <b>DETECTOR FUNCTION</b> | Peak (PK)    |
| <b>FREQUENCY RANGE</b> | 1GHz ~ 40GHz   |                          | Average (AV) |

**ANTENNA POLARITY & TEST DISTANCE: HORIZONTAL AT 3 M**

| NO. | FREQ. (MHz) | EMISSION LEVEL (dBuV/m) | LIMIT (dBuV/m) | MARGIN (dB) | ANTENNA HEIGHT (m) | TABLE ANGLE (Degree) | RAW VALUE (dBuV) | CORRECTION FACTOR (dB/m) |
|-----|-------------|-------------------------|----------------|-------------|--------------------|----------------------|------------------|--------------------------|
| 1   | *5825.00    | 113.3 PK                |                |             | 1.43 H             | 248                  | 101.52           | 11.78                    |
| 2   | *5825.00    | 103.0 AV                |                |             | 1.43 H             | 248                  | 91.22            | 11.78                    |
| 3   | #5850.00    | 63.9 PK                 | 78.2           | -14.3       | 1.43 H             | 248                  | 52.15            | 11.75                    |
| 4   | #5904.00    | 64.0 PK                 | 68.2           | -4.2        | 1.46 H             | 315                  | 52.25            | 11.75                    |
| 5   | 11650.00    | 53.4 PK                 | 74.0           | -20.6       | 1.44 H             | 234                  | 35.24            | 18.16                    |
| 6   | 11650.00    | 40.3 AV                 | 54.0           | -13.7       | 1.44 H             | 234                  | 22.14            | 18.16                    |
| 7   | #17475.00   | 58.7 PK                 | 74.0           | -15.3       | 1.62 H             | 92                   | 30.78            | 27.92                    |
| 8   | #17475.00   | 45.5 AV                 | 54.0           | -8.5        | 1.62 H             | 92                   | 17.58            | 27.92                    |

**ANTENNA POLARITY & TEST DISTANCE: VERTICAL AT 3 M**

| NO. | FREQ. (MHz) | EMISSION LEVEL (dBuV/m) | LIMIT (dBuV/m) | MARGIN (dB) | ANTENNA HEIGHT (m) | TABLE ANGLE (Degree) | RAW VALUE (dBuV) | CORRECTION FACTOR (dB/m) |
|-----|-------------|-------------------------|----------------|-------------|--------------------|----------------------|------------------|--------------------------|
| 1   | *5825.00    | 117.5 PK                |                |             | 1.97 V             | 115                  | 105.72           | 11.78                    |
| 2   | *5825.00    | 107.1 AV                |                |             | 1.97 V             | 115                  | 95.32            | 11.78                    |
| 3   | #5850.00    | 67.7 PK                 | 78.2           | -10.5       | 1.97 V             | 115                  | 55.95            | 11.75                    |
| 4   | #5904.00    | <b>68.1 PK</b>          | <b>68.2</b>    | <b>-0.1</b> | <b>1.63 V</b>      | <b>117</b>           | <b>56.35</b>     | <b>11.75</b>             |
| 5   | 11650.00    | 54.3 PK                 | 74.0           | -19.7       | 1.11 V             | 243                  | 36.14            | 18.16                    |
| 6   | 11650.00    | 41.0 AV                 | 54.0           | -13.0       | 1.11 V             | 243                  | 22.84            | 18.16                    |
| 7   | #17475.00   | 58.7 PK                 | 74.0           | -15.3       | 1.39 V             | 245                  | 30.78            | 27.92                    |
| 8   | #17475.00   | 46.3 AV                 | 54.0           | -7.7        | 1.39 V             | 245                  | 18.38            | 27.92                    |

**REMARKS:**

1. Emission Level(dBuV/m) = Raw Value(dBuV) + Correction Factor(dB/m)
2. Correction Factor(dB/m) = Antenna Factor(dB/m) + Cable Factor(dB) – Pre-Amplifier Factor(dB)
3. The other emission levels were very low against the limit.
4. Margin value = Emission Level – Limit value
5. " \* ": Fundamental frequency.
6. " # ": The radiated frequency is out of the restricted band.

**Beamforming Mode**

**802.11ac (VHT20)**

|                        |                |                          |              |
|------------------------|----------------|--------------------------|--------------|
| <b>CHANNEL</b>         | TX Channel 149 | <b>DETECTOR FUNCTION</b> | Peak (PK)    |
| <b>FREQUENCY RANGE</b> | 1GHz ~ 40GHz   |                          | Average (AV) |

**ANTENNA POLARITY & TEST DISTANCE: HORIZONTAL AT 3 M**

| NO. | FREQ. (MHz) | EMISSION LEVEL (dBuV/m) | LIMIT (dBuV/m) | MARGIN (dB) | ANTENNA HEIGHT (m) | TABLE ANGLE (Degree) | RAW VALUE (dBuV) | CORRECTION FACTOR (dB/m) |
|-----|-------------|-------------------------|----------------|-------------|--------------------|----------------------|------------------|--------------------------|
| 1   | #5666.00    | 63.9 PK                 | 68.2           | -4.3        | 1.42 H             | 300                  | 52.55            | 11.35                    |
| 2   | #5715.00    | 66.7 PK                 | 74.0           | -7.3        | 1.39 H             | 233                  | 55.17            | 11.53                    |
| 3   | #5715.00    | 47.2 AV                 | 54.0           | -6.8        | 1.39 H             | 233                  | 35.67            | 11.53                    |
| 4   | #5725.00    | 73.6 PK                 | 78.2           | -4.6        | 1.41 H             | 260                  | 62.05            | 11.55                    |
| 5   | *5745.00    | 114.2 PK                |                |             | 1.39 H             | 233                  | 102.57           | 11.63                    |
| 6   | *5745.00    | 102.6 AV                |                |             | 1.39 H             | 233                  | 90.97            | 11.63                    |
| 7   | 11490.00    | 53.8 PK                 | 74.0           | -20.2       | 1.39 H             | 220                  | 36.50            | 17.30                    |
| 8   | 11490.00    | 40.5 AV                 | 54.0           | -13.5       | 1.39 H             | 220                  | 23.20            | 17.30                    |
| 9   | #17235.00   | 58.5 PK                 | 74.0           | -15.5       | 1.57 H             | 91                   | 31.69            | 26.81                    |
| 10  | #17235.00   | 45.1 AV                 | 54.0           | -8.9        | 1.57 H             | 91                   | 18.29            | 26.81                    |

**ANTENNA POLARITY & TEST DISTANCE: VERTICAL AT 3 M**

| NO.      | FREQ. (MHz)     | EMISSION LEVEL (dBuV/m) | LIMIT (dBuV/m) | MARGIN (dB) | ANTENNA HEIGHT (m) | TABLE ANGLE (Degree) | RAW VALUE (dBuV) | CORRECTION FACTOR (dB/m) |
|----------|-----------------|-------------------------|----------------|-------------|--------------------|----------------------|------------------|--------------------------|
| 1        | #5666.00        | 68.0 PK                 | 68.2           | -0.2        | 1.74 V             | 114                  | 56.65            | 11.35                    |
| 2        | #5715.00        | 71.0 PK                 | 74.0           | -3.0        | 1.94 V             | 114                  | 59.47            | 11.53                    |
| 3        | #5715.00        | 50.7 AV                 | 54.0           | -3.3        | 1.94 V             | 114                  | 39.17            | 11.53                    |
| <b>4</b> | <b>#5725.00</b> | <b>78.1 PK</b>          | <b>78.2</b>    | <b>-0.1</b> | <b>1.88 V</b>      | <b>112</b>           | <b>66.55</b>     | <b>11.55</b>             |
| 5        | *5745.00        | 118.5 PK                |                |             | 1.94 V             | 114                  | 106.87           | 11.63                    |
| 6        | *5745.00        | 106.7 AV                |                |             | 1.94 V             | 114                  | 95.07            | 11.63                    |
| 7        | 11490.00        | 54.4 PK                 | 74.0           | -19.6       | 1.07 V             | 250                  | 37.10            | 17.30                    |
| 8        | 11490.00        | 41.2 AV                 | 54.0           | -12.8       | 1.07 V             | 250                  | 23.90            | 17.30                    |
| 9        | #17235.00       | 58.7 PK                 | 74.0           | -15.3       | 1.37 V             | 246                  | 31.89            | 26.81                    |
| 10       | #17235.00       | 46.2 AV                 | 54.0           | -7.8        | 1.37 V             | 246                  | 19.39            | 26.81                    |

**REMARKS:**

- Emission Level(dBuV/m) = Raw Value(dBuV) + Correction Factor(dB/m)
- Correction Factor(dB/m) = Antenna Factor(dB/m) + Cable Factor(dB) – Pre-Amplifier Factor(dB)
- The other emission levels were very low against the limit.
- Margin value = Emission Level – Limit value
- " \* ": Fundamental frequency.
- " # ": The radiated frequency is out of the restricted band.



|                        |                |                          |              |
|------------------------|----------------|--------------------------|--------------|
| <b>CHANNEL</b>         | TX Channel 157 | <b>DETECTOR FUNCTION</b> | Peak (PK)    |
| <b>FREQUENCY RANGE</b> | 1GHz ~ 40GHz   |                          | Average (AV) |

**ANTENNA POLARITY & TEST DISTANCE: HORIZONTAL AT 3 M**

| NO. | FREQ. (MHz) | EMISSION LEVEL (dBuV/m) | LIMIT (dBuV/m) | MARGIN (dB) | ANTENNA HEIGHT (m) | TABLE ANGLE (Degree) | RAW VALUE (dBuV) | CORRECTION FACTOR (dB/m) |
|-----|-------------|-------------------------|----------------|-------------|--------------------|----------------------|------------------|--------------------------|
| 1   | #5711.00    | 63.9 PK                 | 68.2           | -4.3        | 1.36 H             | 232                  | 52.39            | 11.51                    |
| 2   | *5785.00    | 113.9 PK                |                |             | 1.36 H             | 232                  | 102.16           | 11.74                    |
| 3   | *5785.00    | 102.1 AV                |                |             | 1.36 H             | 232                  | 90.36            | 11.74                    |
| 4   | #5850.00    | 63.1 PK                 | 78.2           | -15.1       | 1.36 H             | 232                  | 51.35            | 11.75                    |
| 5   | #5863.00    | 63.3 PK                 | 68.2           | -4.9        | 1.48 H             | 299                  | 51.55            | 11.75                    |
| 6   | 11570.00    | 53.6 PK                 | 74.0           | -20.4       | 1.37 H             | 222                  | 35.69            | 17.91                    |
| 7   | 11570.00    | 40.4 AV                 | 54.0           | -13.6       | 1.37 H             | 222                  | 22.49            | 17.91                    |
| 8   | #17355.00   | 58.6 PK                 | 74.0           | -15.4       | 1.63 H             | 82                   | 31.46            | 27.14                    |
| 9   | #17355.00   | 45.5 AV                 | 54.0           | -8.5        | 1.63 H             | 82                   | 18.36            | 27.14                    |

**ANTENNA POLARITY & TEST DISTANCE: VERTICAL AT 3 M**

| NO. | FREQ. (MHz) | EMISSION LEVEL (dBuV/m) | LIMIT (dBuV/m) | MARGIN (dB) | ANTENNA HEIGHT (m) | TABLE ANGLE (Degree) | RAW VALUE (dBuV) | CORRECTION FACTOR (dB/m) |
|-----|-------------|-------------------------|----------------|-------------|--------------------|----------------------|------------------|--------------------------|
| 1   | #5711.00    | 68.1 PK                 | 68.2           | -0.1        | 1.76 V             | 113                  | 56.59            | 11.51                    |
| 2   | *5785.00    | 118.1 PK                |                |             | 1.75 V             | 126                  | 106.36           | 11.74                    |
| 3   | *5785.00    | 106.2 AV                |                |             | 1.75 V             | 126                  | 94.46            | 11.74                    |
| 4   | #5850.00    | 67.4 PK                 | 78.2           | -10.8       | 1.75 V             | 113                  | 55.65            | 11.75                    |
| 5   | #5863.00    | 67.4 PK                 | 68.2           | -0.8        | 1.90 V             | 126                  | 55.65            | 11.75                    |
| 6   | 11570.00    | 53.7 PK                 | 74.0           | -20.3       | 1.07 V             | 234                  | 35.79            | 17.91                    |
| 7   | 11570.00    | 40.8 AV                 | 54.0           | -13.2       | 1.07 V             | 234                  | 22.89            | 17.91                    |
| 8   | #17355.00   | 58.7 PK                 | 74.0           | -15.3       | 1.33 V             | 249                  | 31.56            | 27.14                    |
| 9   | #17355.00   | 46.5 AV                 | 54.0           | -7.5        | 1.33 V             | 249                  | 19.36            | 27.14                    |

**REMARKS:**

1. Emission Level(dBuV/m) = Raw Value(dBuV) + Correction Factor(dB/m)
2. Correction Factor(dB/m) = Antenna Factor(dB/m) + Cable Factor(dB) – Pre-Amplifier Factor(dB)
3. The other emission levels were very low against the limit.
4. Margin value = Emission Level – Limit value
5. " \* ": Fundamental frequency.
6. " # ": The radiated frequency is out of the restricted band.

|                        |                |                              |              |
|------------------------|----------------|------------------------------|--------------|
| <b>CHANNEL</b>         | TX Channel 165 | <b>DETECTOR<br/>FUNCTION</b> | Peak (PK)    |
| <b>FREQUENCY RANGE</b> | 1GHz ~ 40GHz   |                              | Average (AV) |

**ANTENNA POLARITY & TEST DISTANCE: HORIZONTAL AT 3 M**

| NO. | FREQ.<br>(MHz) | EMISSION<br>LEVEL<br>(dBuV/m) | LIMIT<br>(dBuV/m) | MARGIN<br>(dB) | ANTENNA<br>HEIGHT<br>(m) | TABLE<br>ANGLE<br>(Degree) | RAW<br>VALUE<br>(dBuV) | CORRECTION<br>FACTOR<br>(dB/m) |
|-----|----------------|-------------------------------|-------------------|----------------|--------------------------|----------------------------|------------------------|--------------------------------|
| 1   | *5825.00       | 112.8 PK                      |                   |                | 1.33 H                   | 236                        | 101.02                 | 11.78                          |
| 2   | *5825.00       | 100.8 AV                      |                   |                | 1.33 H                   | 236                        | 89.02                  | 11.78                          |
| 3   | #5850.00       | 65.3 PK                       | 78.2              | -12.9          | 1.33 H                   | 236                        | 53.55                  | 11.75                          |
| 4   | #5904.00       | 63.8 PK                       | 68.2              | -4.4           | 1.33 H                   | 236                        | 52.05                  | 11.75                          |
| 5   | 11650.00       | 53.1 PK                       | 74.0              | -20.9          | 1.33 H                   | 229                        | 34.94                  | 18.16                          |
| 6   | 11650.00       | 40.2 AV                       | 54.0              | -13.8          | 1.33 H                   | 229                        | 22.04                  | 18.16                          |
| 7   | #17475.00      | 58.8 PK                       | 74.0              | -15.2          | 1.69 H                   | 93                         | 30.88                  | 27.92                          |
| 8   | #17475.00      | 45.6 AV                       | 54.0              | -8.4           | 1.69 H                   | 93                         | 17.68                  | 27.92                          |

**ANTENNA POLARITY & TEST DISTANCE: VERTICAL AT 3 M**

| NO. | FREQ.<br>(MHz) | EMISSION<br>LEVEL<br>(dBuV/m) | LIMIT<br>(dBuV/m) | MARGIN<br>(dB) | ANTENNA<br>HEIGHT<br>(m) | TABLE<br>ANGLE<br>(Degree) | RAW<br>VALUE<br>(dBuV) | CORRECTION<br>FACTOR<br>(dB/m) |
|-----|----------------|-------------------------------|-------------------|----------------|--------------------------|----------------------------|------------------------|--------------------------------|
| 1   | *5825.00       | 117.0 PK                      |                   |                | 1.65 V                   | 106                        | 105.22                 | 11.78                          |
| 2   | *5825.00       | 104.9 AV                      |                   |                | 1.65 V                   | 106                        | 93.12                  | 11.78                          |
| 3   | #5850.00       | 69.5 PK                       | 78.2              | -8.7           | 1.80 V                   | 125                        | 57.75                  | 11.75                          |
| 4   | #5904.00       | <b>68.1 PK</b>                | <b>68.2</b>       | <b>-0.1</b>    | <b>1.80 V</b>            | <b>125</b>                 | <b>56.35</b>           | <b>11.75</b>                   |
| 5   | 11650.00       | 54.4 PK                       | 74.0              | -19.6          | 1.03 V                   | 236                        | 36.24                  | 18.16                          |
| 6   | 11650.00       | 41.2 AV                       | 54.0              | -12.8          | 1.03 V                   | 236                        | 23.04                  | 18.16                          |
| 7   | #17475.00      | 58.1 PK                       | 74.0              | -15.9          | 1.35 V                   | 242                        | 30.18                  | 27.92                          |
| 8   | #17475.00      | 46.0 AV                       | 54.0              | -8.0           | 1.35 V                   | 242                        | 18.08                  | 27.92                          |

**REMARKS:**

1. Emission Level(dBuV/m) = Raw Value(dBuV) + Correction Factor(dB/m)
2. Correction Factor(dB/m) = Antenna Factor(dB/m) + Cable Factor(dB) – Pre-Amplifier Factor(dB)
3. The other emission levels were very low against the limit.
4. Margin value = Emission Level – Limit value
5. " \* ": Fundamental frequency.
6. " # ": The radiated frequency is out of the restricted band.

**802.11ac (VHT40)**

|                        |                |                          |              |
|------------------------|----------------|--------------------------|--------------|
| <b>CHANNEL</b>         | TX Channel 151 | <b>DETECTOR FUNCTION</b> | Peak (PK)    |
| <b>FREQUENCY RANGE</b> | 1GHz ~ 40GHz   |                          | Average (AV) |

**ANTENNA POLARITY & TEST DISTANCE: HORIZONTAL AT 3 M**

| NO. | FREQ. (MHz) | EMISSION LEVEL (dBuV/m) | LIMIT (dBuV/m) | MARGIN (dB) | ANTENNA HEIGHT (m) | TABLE ANGLE (Degree) | RAW VALUE (dBuV) | CORRECTION FACTOR (dB/m) |
|-----|-------------|-------------------------|----------------|-------------|--------------------|----------------------|------------------|--------------------------|
| 1   | #5715.00    | 63.8 PK                 | 68.2           | -4.4        | 1.28 H             | 230                  | 52.27            | 11.53                    |
| 2   | #5725.00    | 73.2 PK                 | 78.2           | -5.0        | 1.28 H             | 230                  | 61.65            | 11.55                    |
| 3   | *5755.00    | 109.3 PK                |                |             | 1.28 H             | 230                  | 97.66            | 11.64                    |
| 4   | *5755.00    | 98.2 AV                 |                |             | 1.28 H             | 230                  | 86.56            | 11.64                    |
| 5   | #5850.00    | 59.7 PK                 | 78.2           | -18.5       | 1.28 H             | 230                  | 47.95            | 11.75                    |
| 6   | #5919.00    | 58.2 PK                 | 74.0           | -15.8       | 1.45 H             | 118                  | 46.37            | 11.83                    |
| 7   | #5919.00    | 47.4 AV                 | 54.0           | -6.6        | 1.45 H             | 118                  | 35.57            | 11.83                    |
| 8   | 11510.00    | 53.4 PK                 | 74.0           | -20.6       | 1.33 H             | 243                  | 36.10            | 17.30                    |
| 9   | 11510.00    | 40.6 AV                 | 54.0           | -13.4       | 1.33 H             | 243                  | 23.30            | 17.30                    |
| 10  | #17265.00   | 58.6 PK                 | 74.0           | -15.4       | 1.74 H             | 80                   | 31.89            | 26.71                    |
| 11  | #17265.00   | 45.6 AV                 | 54.0           | -8.4        | 1.74 H             | 80                   | 18.89            | 26.71                    |

**ANTENNA POLARITY & TEST DISTANCE: VERTICAL AT 3 M**

| NO. | FREQ. (MHz) | EMISSION LEVEL (dBuV/m) | LIMIT (dBuV/m) | MARGIN (dB) | ANTENNA HEIGHT (m) | TABLE ANGLE (Degree) | RAW VALUE (dBuV) | CORRECTION FACTOR (dB/m) |
|-----|-------------|-------------------------|----------------|-------------|--------------------|----------------------|------------------|--------------------------|
| 1   | #5715.00    | 68.0 PK                 | 68.2           | -0.2        | 1.87 V             | 114                  | 56.47            | 11.53                    |
| 2   | #5725.00    | 77.8 PK                 | 78.2           | -0.4        | 1.87 V             | 114                  | 66.25            | 11.55                    |
| 3   | *5755.00    | 114.2 PK                |                |             | 1.87 V             | 114                  | 102.56           | 11.64                    |
| 4   | *5755.00    | 102.4 AV                |                |             | 1.87 V             | 114                  | 90.76            | 11.64                    |
| 5   | #5850.00    | 63.9 PK                 | 78.2           | -14.3       | 1.87 V             | 114                  | 52.15            | 11.75                    |
| 6   | #5919.00    | 62.7 PK                 | 74.0           | -11.3       | 1.66 V             | 127                  | 50.87            | 11.83                    |
| 7   | #5919.00    | 51.6 AV                 | 54.0           | -2.4        | 1.66 V             | 127                  | 39.77            | 11.83                    |
| 8   | 11510.00    | 54.2 PK                 | 74.0           | -19.8       | 1.07 V             | 241                  | 36.90            | 17.30                    |
| 9   | 11510.00    | 41.2 AV                 | 54.0           | -12.8       | 1.07 V             | 241                  | 23.90            | 17.30                    |
| 10  | #17265.00   | 58.7 PK                 | 74.0           | -15.3       | 1.33 V             | 249                  | 31.99            | 26.71                    |
| 11  | #17265.00   | 46.3 AV                 | 54.0           | -7.7        | 1.33 V             | 249                  | 19.59            | 26.71                    |

**REMARKS:**

1. Emission Level(dBuV/m) = Raw Value(dBuV) + Correction Factor(dB/m)
2. Correction Factor(dB/m) = Antenna Factor(dB/m) + Cable Factor(dB) – Pre-Amplifier Factor(dB)
3. The other emission levels were very low against the limit.
4. Margin value = Emission Level – Limit value
5. " \* ": Fundamental frequency.
6. " # ": The radiated frequency is out of the restricted band.

|                        |                |                          |              |
|------------------------|----------------|--------------------------|--------------|
| <b>CHANNEL</b>         | TX Channel 159 | <b>DETECTOR FUNCTION</b> | Peak (PK)    |
| <b>FREQUENCY RANGE</b> | 1GHz ~ 40GHz   |                          | Average (AV) |

**ANTENNA POLARITY & TEST DISTANCE: HORIZONTAL AT 3 M**

| NO. | FREQ. (MHz) | EMISSION LEVEL (dBuV/m) | LIMIT (dBuV/m) | MARGIN (dB) | ANTENNA HEIGHT (m) | TABLE ANGLE (Degree) | RAW VALUE (dBuV) | CORRECTION FACTOR (dB/m) |
|-----|-------------|-------------------------|----------------|-------------|--------------------|----------------------|------------------|--------------------------|
| 1   | #5715.00    | 60.2 PK                 | 74.0           | -13.8       | 1.32 H             | 239                  | 48.67            | 11.53                    |
| 2   | #5715.00    | 49.1 AV                 | 54.0           | -4.9        | 1.32 H             | 239                  | 37.57            | 11.53                    |
| 3   | *5795.00    | 108.5 PK                |                |             | 1.32 H             | 239                  | 96.72            | 11.78                    |
| 4   | *5795.00    | 97.3 AV                 |                |             | 1.32 H             | 239                  | 85.52            | 11.78                    |
| 5   | #5850.00    | 62.1 PK                 | 78.2           | -16.1       | 1.32 H             | 239                  | 50.35            | 11.75                    |
| 6   | #5860.00    | 63.8 PK                 | 74.0           | -10.2       | 1.32 H             | 239                  | 52.05            | 11.75                    |
| 7   | #5860.00    | 49.2 AV                 | 54.0           | -4.8        | 1.32 H             | 239                  | 37.45            | 11.75                    |
| 8   | 11590.00    | 53.8 PK                 | 74.0           | -20.2       | 1.34 H             | 246                  | 35.69            | 18.11                    |
| 9   | 11590.00    | 41.1 AV                 | 54.0           | -12.9       | 1.34 H             | 246                  | 22.99            | 18.11                    |
| 10  | #17385.00   | 58.5 PK                 | 74.0           | -15.5       | 1.68 H             | 85                   | 31.05            | 27.45                    |
| 11  | #17385.00   | 45.5 AV                 | 54.0           | -8.5        | 1.68 H             | 85                   | 18.05            | 27.45                    |

**ANTENNA POLARITY & TEST DISTANCE: VERTICAL AT 3 M**

| NO. | FREQ. (MHz) | EMISSION LEVEL (dBuV/m) | LIMIT (dBuV/m) | MARGIN (dB) | ANTENNA HEIGHT (m) | TABLE ANGLE (Degree) | RAW VALUE (dBuV) | CORRECTION FACTOR (dB/m) |
|-----|-------------|-------------------------|----------------|-------------|--------------------|----------------------|------------------|--------------------------|
| 1   | #5715.00    | 64.3 PK                 | 74.0           | -9.7        | 1.88 V             | 111                  | 52.77            | 11.53                    |
| 2   | #5715.00    | 53.3 AV                 | 54.0           | -0.7        | 1.88 V             | 111                  | 41.77            | 11.53                    |
| 3   | *5795.00    | 113.6 PK                |                |             | 1.88 V             | 111                  | 101.82           | 11.78                    |
| 4   | *5795.00    | 101.8 AV                |                |             | 1.88 V             | 111                  | 90.02            | 11.78                    |
| 5   | #5850.00    | 66.6 PK                 | 78.2           | -11.6       | 1.88 V             | 111                  | 54.85            | 11.75                    |
| 6   | #5860.00    | 68.4 PK                 | 74.0           | -5.6        | 1.88 V             | 111                  | 56.65            | 11.75                    |
| 7   | #5860.00    | 53.7 AV                 | 54.0           | -0.3        | 1.88 V             | 111                  | 41.95            | 11.75                    |
| 8   | 11590.00    | 54.0 PK                 | 74.0           | -20.0       | 1.12 V             | 248                  | 35.89            | 18.11                    |
| 9   | 11590.00    | 41.2 AV                 | 54.0           | -12.8       | 1.12 V             | 248                  | 23.09            | 18.11                    |
| 10  | #17385.00   | 59.1 PK                 | 74.0           | -14.9       | 1.37 V             | 261                  | 31.65            | 27.45                    |
| 11  | #17385.00   | 46.5 AV                 | 54.0           | -7.5        | 1.37 V             | 261                  | 19.05            | 27.45                    |

**REMARKS:**

1. Emission Level(dBuV/m) = Raw Value(dBuV) + Correction Factor(dB/m)
2. Correction Factor(dB/m) = Antenna Factor(dB/m) + Cable Factor(dB) – Pre-Amplifier Factor(dB)
3. The other emission levels were very low against the limit.
4. Margin value = Emission Level – Limit value
5. " \* ": Fundamental frequency.
6. " # ": The radiated frequency is out of the restricted band.

**802.11ac (VHT80)**

|                        |                |                          |              |
|------------------------|----------------|--------------------------|--------------|
| <b>CHANNEL</b>         | TX Channel 155 | <b>DETECTOR FUNCTION</b> | Peak (PK)    |
| <b>FREQUENCY RANGE</b> | 1GHz ~ 40GHz   |                          | Average (AV) |

**ANTENNA POLARITY & TEST DISTANCE: HORIZONTAL AT 3 M**

| NO. | FREQ. (MHz) | EMISSION LEVEL (dBuV/m) | LIMIT (dBuV/m) | MARGIN (dB) | ANTENNA HEIGHT (m) | TABLE ANGLE (Degree) | RAW VALUE (dBuV) | CORRECTION FACTOR (dB/m) |
|-----|-------------|-------------------------|----------------|-------------|--------------------|----------------------|------------------|--------------------------|
| 1   | #5715.00    | 64.8 PK                 | 74.0           | -9.2        | 1.30 H             | 253                  | 53.27            | 11.53                    |
| 2   | #5715.00    | 49.3 AV                 | 54.0           | -4.7        | 1.30 H             | 253                  | 37.77            | 11.53                    |
| 3   | #5725.00    | 69.0 PK                 | 78.2           | -9.2        | 1.30 H             | 253                  | 57.45            | 11.55                    |
| 4   | *5775.00    | 102.8 PK                |                |             | 1.30 H             | 253                  | 91.08            | 11.72                    |
| 5   | *5775.00    | 91.6 AV                 |                |             | 1.30 H             | 253                  | 79.88            | 11.72                    |
| 6   | #5850.00    | 61.3 PK                 | 78.2           | -16.9       | 1.30 H             | 253                  | 49.55            | 11.75                    |
| 7   | 11550.00    | 53.7 PK                 | 74.0           | -20.3       | 1.32 H             | 258                  | 35.99            | 17.71                    |
| 8   | 11550.00    | 40.9 AV                 | 54.0           | -13.1       | 1.32 H             | 258                  | 23.19            | 17.71                    |
| 9   | #17325.00   | 58.7 PK                 | 74.0           | -15.3       | 1.66 H             | 95                   | 31.85            | 26.85                    |
| 10  | #17325.00   | 45.5 AV                 | 54.0           | -8.5        | 1.66 H             | 95                   | 18.65            | 26.85                    |

**ANTENNA POLARITY & TEST DISTANCE: VERTICAL AT 3 M**

| NO. | FREQ. (MHz) | EMISSION LEVEL (dBuV/m) | LIMIT (dBuV/m) | MARGIN (dB) | ANTENNA HEIGHT (m) | TABLE ANGLE (Degree) | RAW VALUE (dBuV) | CORRECTION FACTOR (dB/m) |
|-----|-------------|-------------------------|----------------|-------------|--------------------|----------------------|------------------|--------------------------|
| 1   | #5715.00    | 69.3 PK                 | 74.0           | -4.7        | 1.87 V             | 116                  | 57.77            | 11.53                    |
| 2   | #5715.00    | 53.7 AV                 | 54.0           | -0.3        | 1.87 V             | 116                  | 42.17            | 11.53                    |
| 3   | #5725.00    | 74.1 PK                 | 78.2           | -4.1        | 1.87 V             | 116                  | 62.55            | 11.55                    |
| 4   | *5775.00    | 108.4 PK                |                |             | 1.87 V             | 116                  | 96.68            | 11.72                    |
| 5   | *5775.00    | 96.2 AV                 |                |             | 1.87 V             | 116                  | 84.48            | 11.72                    |
| 6   | #5850.00    | 65.9 PK                 | 78.2           | -12.3       | 1.87 V             | 116                  | 54.15            | 11.75                    |
| 7   | 11550.00    | 53.8 PK                 | 74.0           | -20.2       | 1.08 V             | 241                  | 36.09            | 17.71                    |
| 8   | 11550.00    | 41.0 AV                 | 54.0           | -13.0       | 1.08 V             | 241                  | 23.29            | 17.71                    |
| 9   | #17325.00   | 58.7 PK                 | 74.0           | -15.3       | 1.34 V             | 249                  | 31.85            | 26.85                    |
| 10  | #17325.00   | 46.4 AV                 | 54.0           | -7.6        | 1.34 V             | 249                  | 19.55            | 26.85                    |

**REMARKS:**

1. Emission Level(dBuV/m) = Raw Value(dBuV) + Correction Factor(dB/m)
2. Correction Factor(dB/m) = Antenna Factor(dB/m) + Cable Factor(dB) – Pre-Amplifier Factor(dB)
3. The other emission levels were very low against the limit.
4. Margin value = Emission Level – Limit value
5. " \* ": Fundamental frequency.
6. " # ": The radiated frequency is out of the restricted band.

**Below 1GHz Data**

**Beamforming MODE**

**802.11ac (VHT20)**

|                        |                |                          |                 |
|------------------------|----------------|--------------------------|-----------------|
| <b>CHANNEL</b>         | TX Channel 149 | <b>DETECTOR FUNCTION</b> | Quasi-Peak (QP) |
| <b>FREQUENCY RANGE</b> | Below 1GHz     |                          |                 |

**ANTENNA POLARITY & TEST DISTANCE: HORIZONTAL AT 3 M**

| NO. | FREQ. (MHz) | EMISSION LEVEL (dBuV/m) | LIMIT (dBuV/m) | MARGIN (dB) | ANTENNA HEIGHT (m) | TABLE ANGLE (Degree) | RAW VALUE (dBuV) | CORRECTION FACTOR (dB/m) |
|-----|-------------|-------------------------|----------------|-------------|--------------------|----------------------|------------------|--------------------------|
| 1   | 125.01      | 32.5 QP                 | 43.5           | -11.0       | 2.00 H             | 256                  | 47.36            | -14.85                   |
| 2   | 250.00      | 42.9 QP                 | 46.0           | -3.2        | 1.00 H             | 118                  | 56.86            | -14.01                   |
| 3   | 375.03      | 35.8 QP                 | 46.0           | -10.2       | 1.00 H             | 315                  | 45.79            | -9.97                    |
| 4   | 500.01      | 34.5 QP                 | 46.0           | -11.5       | 1.50 H             | 156                  | 41.33            | -6.83                    |
| 5   | 749.98      | 36.6 QP                 | 46.0           | -9.4        | 1.00 H             | 360                  | 37.77            | -1.21                    |
| 6   | 875.02      | 40.3 QP                 | 46.0           | -5.7        | 1.50 H             | 230                  | 40.09            | 0.24                     |

**ANTENNA POLARITY & TEST DISTANCE: VERTICAL AT 3 M**

| NO. | FREQ. (MHz) | EMISSION LEVEL (dBuV/m) | LIMIT (dBuV/m) | MARGIN (dB) | ANTENNA HEIGHT (m) | TABLE ANGLE (Degree) | RAW VALUE (dBuV) | CORRECTION FACTOR (dB/m) |
|-----|-------------|-------------------------|----------------|-------------|--------------------|----------------------|------------------|--------------------------|
| 1   | 47.80       | 34.6 QP                 | 40.0           | -5.4        | 1.00 V             | 122                  | 47.68            | -13.04                   |
| 2   | 66.28       | 32.1 QP                 | 40.0           | -8.0        | 1.00 V             | 44                   | 46.51            | -14.46                   |
| 3   | 125.01      | 30.7 QP                 | 43.5           | -12.8       | 1.00 V             | 227                  | 45.58            | -14.85                   |
| 4   | 250.00      | 37.9 QP                 | 46.0           | -8.1        | 2.00 V             | 360                  | 51.90            | -14.01                   |
| 5   | 375.03      | 35.9 QP                 | 46.0           | -10.1       | 1.50 V             | 273                  | 45.83            | -9.97                    |
| 6   | 500.01      | 37.4 QP                 | 46.0           | -8.7        | 1.00 V             | 298                  | 44.18            | -6.83                    |

**REMARKS:**

1. Emission Level(dBuV/m) = Raw Value(dBuV) + Correction Factor(dB/m)
2. Correction Factor(dB/m) = Antenna Factor(dB/m) + Cable Factor(dB) – Pre-Amplifier Factor(dB)
3. The other emission levels were very low against the limit.
4. Margin value = Emission Level – Limit value

## 4.2 Transmit Power Measurement

### 4.2.1 Limits of Transmit Power Measurement

| Operation Band | EUT Category |                                   | Limit   |
|----------------|--------------|-----------------------------------|---|
| U-NII-1        |              | Outdoor Access Point              | 1 Watt (30 dBm)<br>(Max. e.i.r.p $\leq$ 125mW(21 dBm) at any elevation angle above 30 degrees as measured from the horizon) |
|                |              | Fixed point-to-point Access Point | 1 Watt (30 dBm)   |
|                |              | Indoor Access Point               | 1 Watt (30 dBm)   |
|                |              | Mobile and Portable client device | 250mW (24 dBm)  |
| U-NII-2A       |              |                                   | 250mW (24 dBm) or 11 dBm+10 log B*  |
| U-NII-2C       |              |                                   | 250mW (24 dBm) or 11 dBm+10 log B*  |
| U-NII-3        | √            |                                   | 1 Watt (30 dBm)   |

\*B is the 26 dB emission bandwidth in megahertz

Per KDB 662911 Method of conducted output power measurement on IEEE 802.11 devices,

Array Gain = 0 dB (i.e., no array gain) for  $N_{ANT} \leq 4$ ;

Array Gain = 0 dB (i.e., no array gain) for channel widths  $\geq 40$  MHz for any  $N_{ANT}$ ;

Array Gain = 5 log( $N_{ANT}/N_{SS}$ ) dB or 3 dB, whichever is less for 20-MHz channel widths with  $N_{ANT} \geq 5$ .

For power measurements on all other devices: Array Gain = 10 log( $N_{ANT}/N_{SS}$ ) dB.

### 4.2.2 Test Setup

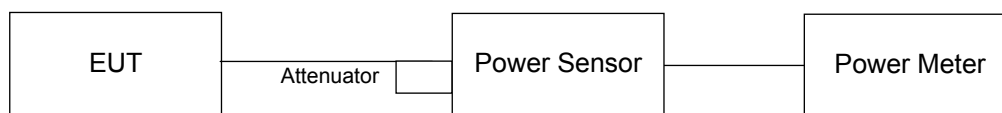

### 4.2.3 Test Instruments

Refer to section 4.1.2 to get information of above instrument.

### 4.2.4 Test Procedure

Method PM is used to perform output power measurement, trigger and gating function of wide band power meter is enabled to measure max output power of TX on burst. Duty factor is not added to measured value.

### 4.2.5 Deviation from Test Standard

No deviation.

### 4.2.6 EUT Operating Condition

The software provided by client to enable the EUT under transmission condition continuously at lowest, middle and highest channel frequencies individually.

#### 4.2.7 Test Result

##### CDD Mode

| Chan.          | Chan. Freq. (MHz) | Maximum Conducted Power (dBm) |         |         | Total Power (mW) | Total Power (dBm) | Limit (dBm) | Pass / Fail |
|----------------|-------------------|-------------------------------|---------|---------|------------------|-------------------|-------------|-------------|
|                |                   | Chain 0                       | Chain 1 | Chain 2 |                  |                   |             |             |
| <b>802.11a</b> |                   |                               |         |         |                  |                   |             |             |
| 149            | 5745              | 18.83                         | 19.28   | 19.14   | 243.142          | 23.86             | 30          | Pass        |
| 157            | 5785              | 17.86                         | 18.34   | 18.39   | 198.352          | 22.97             | 30          | Pass        |
| 165            | 5825              | 17.88                         | 18.37   | 18.38   | 198.948          | 22.99             | 30          | Pass        |

##### Beamforming Mode

| Chan.                   | Chan. Freq. (MHz) | Maximum Conducted Power (dBm) |         |         | Total Power (mW) | Total Power (dBm) | Limit (dBm) | Pass / Fail |
|-------------------------|-------------------|-------------------------------|---------|---------|------------------|-------------------|-------------|-------------|
|                         |                   | Chain 0                       | Chain 1 | Chain 2 |                  |                   |             |             |
| <b>802.11ac (VHT20)</b> |                   |                               |         |         |                  |                   |             |             |
| 149                     | 5745              | 18.31                         | 18.82   | 18.73   | 218.617          | 23.40             | 29.23       | Pass        |
| 157                     | 5785              | 18.21                         | 18.43   | 18.69   | 209.846          | 23.22             | 29.23       | Pass        |
| 165                     | 5825              | 17.18                         | 17.73   | 17.72   | 170.689          | 22.32             | 29.23       | Pass        |
| <b>802.11ac (VHT40)</b> |                   |                               |         |         |                  |                   |             |             |
| 151                     | 5755              | 17.03                         | 17.49   | 17.34   | 160.771          | 22.06             | 29.23       | Pass        |
| 159                     | 5795              | 17.37                         | 17.71   | 17.69   | 172.345          | 22.36             | 29.23       | Pass        |
| <b>802.11ac (VHT80)</b> |                   |                               |         |         |                  |                   |             |             |
| 155                     | 5775              | 14.74                         | 15.23   | 15.45   | 98.203           | 19.92             | 29.23       | Pass        |

Note: 1. Directional gain =  $2\text{dBi} + 10\log(3) = 6.77\text{dBi} > 6\text{dBi}$  , so the power limit shall be reduced to  $30 - (6.77 - 6) = 29.23\text{dBm}$ .



### 4.3 Peak Power Spectral Density Measurement

#### 4.3.1 Limits of Peak Power Spectral Density Measurement

| Operation Band | EUT Category |                                   | Limit         |
|----------------|--------------|-----------------------------------|---------------|
| U-NII-1        |              | Outdoor Access Point              | 17dBm/ MHz    |
|                |              | Fixed point-to-point Access Point |               |
|                |              | Indoor Access Point               |               |
|                |              | Mobile and Portable client device | 11dBm/ MHz    |
| U-NII-2A       |              |                                   | 11dBm/ MHz    |
| U-NII-2C       |              |                                   | 11dBm/ MHz    |
| U-NII-3        |              | √                                 | 30dBm/ 500kHz |

#### 4.3.2 Test Setup

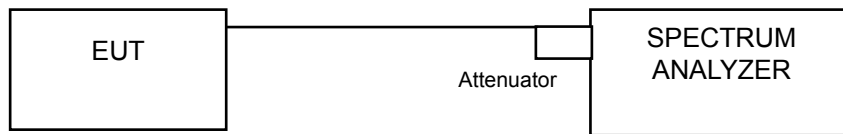

#### 4.3.3 Test Instruments

Refer to section 4.1.2 to get information of above instrument.

#### 4.3.4 Test Procedure

##### For AVG. power (duty cycle ≥ 98%)

1. Set span to encompass the entire emission bandwidth (EBW) of the signal.
2. Set RBW = 300 kHz, Set VBW ≥ 1 MHz, Detector = RMS
3. Use the peak marker function to determine the maximum power level in any 300 kHz band segment within the fundamental EBW.
4. Scale the observed power level to an equivalent value in 500 kHz by adjusting (reducing) the measured power by a bandwidth correction factor (BWCF) where  $BWCF = 10\log(500\text{kHz}/300\text{kHz})$
5. Sweep time = auto, trigger set to “free run”.
6. Trace average at least 100 traces in power averaging mode.
7. Record the max value

##### For AVG. power (duty cycle < 98%)

1. Set span to encompass the entire emission bandwidth (EBW) of the signal.
2. Set RBW = 300 kHz, Set VBW ≥ 1 MHz, Detector = RMS
3. Use the peak marker function to determine the maximum power level in any 300 kHz band segment within the fundamental EBW.
4. Scale the observed power level to an equivalent value in 500 kHz by adjusting (reducing) the measured power by a bandwidth correction factor (BWCF) where  $BWCF = 10\log(500\text{kHz}/300\text{kHz})$
5. Sweep time = auto, trigger set to “free run”.
6. Trace average at least 100 traces in power averaging mode.
7. Record the max value and add  $10 \log (1/\text{duty cycle})$

#### 4.3.5 Deviation from Test Standard

No deviation.

#### 4.3.6 EUT Operating Condition

Same as Item 4.2.6.

### 4.3.7 Test Results

#### CDD Mode

| TX chain       | Channel | Freq. (MHz) | PSD (dBm/300kHz) | PSD (dBm/500kHz) | 10 log (N=3) dB | Total PSD (dBm/500kHz) | Limit (dBm/500kHz) | Pass /Fail |
|----------------|---------|-------------|------------------|------------------|-----------------|------------------------|--------------------|------------|
| <b>802.11a</b> |         |             |                  |                  |                 |                        |                    |            |
| 0              | 149     | 5745        | -2.95            | -0.73            | 4.77            | 4.04                   | 29.23              | Pass       |
|                | 157     | 5785        | -3.68            | -1.46            | 4.77            | 3.31                   | 29.23              | Pass       |
|                | 165     | 5825        | -3.56            | -1.34            | 4.77            | 3.43                   | 29.23              | Pass       |
| 1              | 149     | 5745        | -1.57            | 0.65             | 4.77            | 5.42                   | 29.23              | Pass       |
|                | 157     | 5785        | -2.47            | -0.25            | 4.77            | 4.52                   | 29.23              | Pass       |
|                | 165     | 5825        | -2.23            | -0.01            | 4.77            | 4.76                   | 29.23              | Pass       |
| 2              | 149     | 5745        | -1.92            | 0.30             | 4.77            | 5.07                   | 29.23              | Pass       |
|                | 157     | 5785        | -3.17            | -0.95            | 4.77            | 3.82                   | 29.23              | Pass       |
|                | 165     | 5825        | -2.86            | -0.64            | 4.77            | 4.13                   | 29.23              | Pass       |

Note: 1. Directional gain = 2dBi + 10log(3) = 6.77dBi > 6dBi , so the power density limit shall be reduced to 30-(6.77-6) = 29.23dBm.

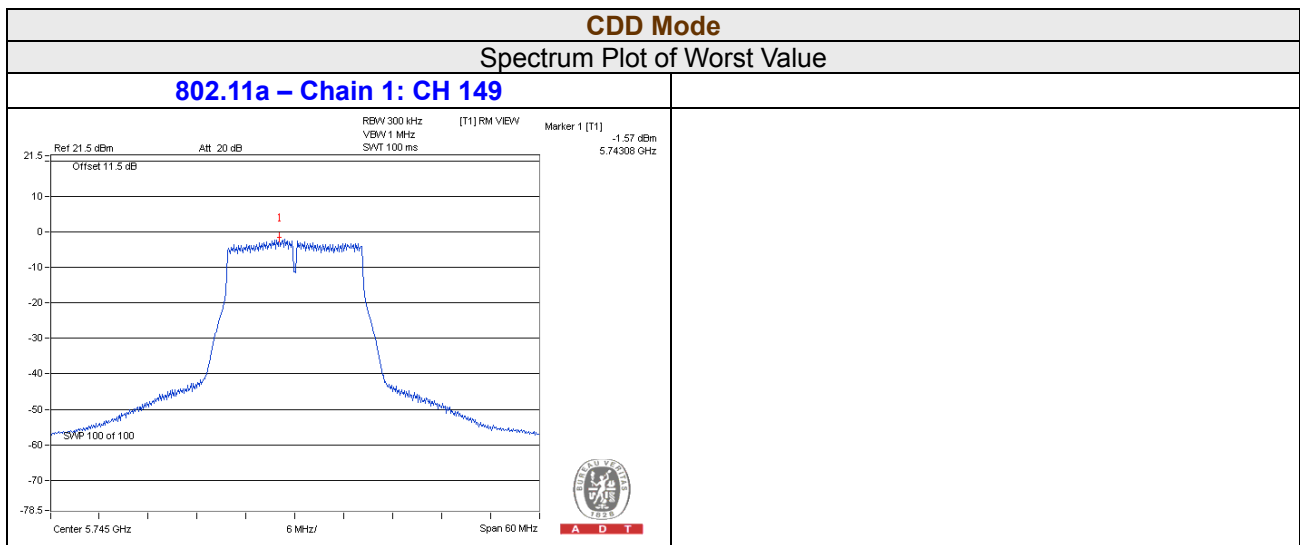

**Beamforming Mode**

| TX chain                | Channel | Freq. (MHz) | PSD (dBm/300kHz) | PSD (dBm/500kHz) | 10 log (N=3) dB | Total PSD (dBm/500kHz) | Limit (dBm/500kHz) | Pass /Fail |
|-------------------------|---------|-------------|------------------|------------------|-----------------|------------------------|--------------------|------------|
| <b>802.11ac (VHT20)</b> |         |             |                  |                  |                 |                        |                    |            |
| 0                       | 149     | 5745        | -3.09            | -0.87            | 4.77            | 3.90                   | 29.23              | Pass       |
|                         | 157     | 5785        | -3.31            | -1.09            | 4.77            | 3.68                   | 29.23              | Pass       |
|                         | 165     | 5825        | -4.10            | -1.88            | 4.77            | 2.89                   | 29.23              | Pass       |
| 1                       | 149     | 5745        | -2.91            | -0.69            | 4.77            | 4.08                   | 29.23              | Pass       |
|                         | 157     | 5785        | -2.84            | -0.62            | 4.77            | 4.15                   | 29.23              | Pass       |
|                         | 165     | 5825        | -3.80            | -1.58            | 4.77            | 3.19                   | 29.23              | Pass       |
| 2                       | 149     | 5745        | -2.93            | -0.71            | 4.77            | 4.06                   | 29.23              | Pass       |
|                         | 157     | 5785        | -3.20            | -0.98            | 4.77            | 3.79                   | 29.23              | Pass       |
|                         | 165     | 5825        | -3.67            | -1.45            | 4.77            | 3.32                   | 29.23              | Pass       |

| TX chain                | Chan. | Chan. Freq. (MHz) | PSD W/O Duty Factor |              | 10 log (N=3) dB | Duty Factor (dB) | Total PSD With Duty Factor (dBm/500kHz) | Limit (dBm/500kHz) | Pass /Fail |
|-------------------------|-------|-------------------|---------------------|--------------|-----------------|------------------|---|--------------------|------------|
|                         |       |                   | (dBm/300kHz)        | (dBm/500kHz) |                 |                  |   |                    |            |
| <b>802.11ac (VHT40)</b> |       |                   |                     |              |                 |                  |   |                    |            |
| 0                       | 151   | 5755              | -8.19               | -5.97        | 4.77            | 0.17             | -1.03                                   | 29.23              | Pass       |
|                         | 159   | 5795              | -7.68               | -5.46        | 4.77            | 0.17             | -0.52                                   | 29.23              | Pass       |
| 1                       | 151   | 5755              | -7.85               | -5.63        | 4.77            | 0.17             | -0.69                                   | 29.23              | Pass       |
|                         | 159   | 5795              | -7.61               | -5.39        | 4.77            | 0.17             | -0.45                                   | 29.23              | Pass       |
| 2                       | 151   | 5755              | -7.92               | -5.70        | 4.77            | 0.17             | -0.76                                   | 29.23              | Pass       |
|                         | 159   | 5795              | -7.21               | -4.99        | 4.77            | 0.17             | -0.05                                   | 29.23              | Pass       |

**802.11ac (VHT80)**

|   |     |      |        |        |      |      |       |       |      |
|---|-----|------|--------|--------|------|------|-------|-------|------|
| 0 | 155 | 5775 | -13.77 | -11.55 | 4.77 | 0.38 | -6.40 | 29.23 | Pass |
| 1 | 155 | 5775 | -13.22 | -11.00 | 4.77 | 0.38 | -5.85 | 29.23 | Pass |
| 2 | 155 | 5775 | -12.78 | -10.56 | 4.77 | 0.38 | -5.41 | 29.23 | Pass |

Note: 1. Directional gain =  $2\text{dBi} + 10\log(3) = 6.77\text{dBi} > 6\text{dBi}$  , so the power density limit shall be reduced to  $30 - (6.77 - 6) = 29.23\text{dBm}$ .

2. Refer to section 3.3 for duty cycle spectrum plot.

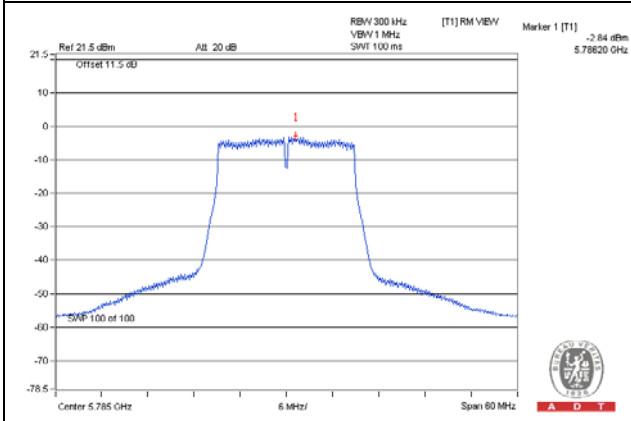
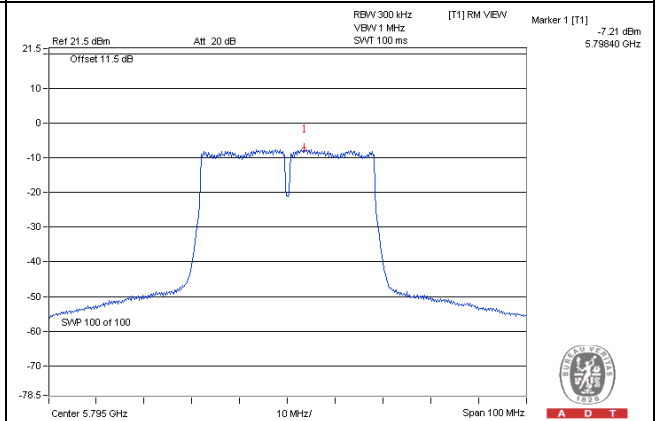
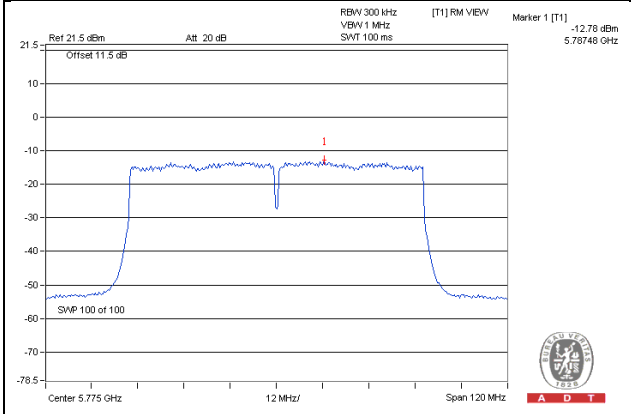
**Beamforming Mode****Spectrum Plot of Worst Value****802.11ac (VHT20) – Chain 1: CH 157****802.11ac (VHT40) – Chain 2: CH 159****802.11ac (VHT80) – Chain 2: CH 155**

## 4.4 Frequency Stability Measurement

### 4.4.1 Limits of Frequency Stability Measurement

The frequency of the carrier signal shall be maintained within band of operation

### 4.4.2 Test Setup

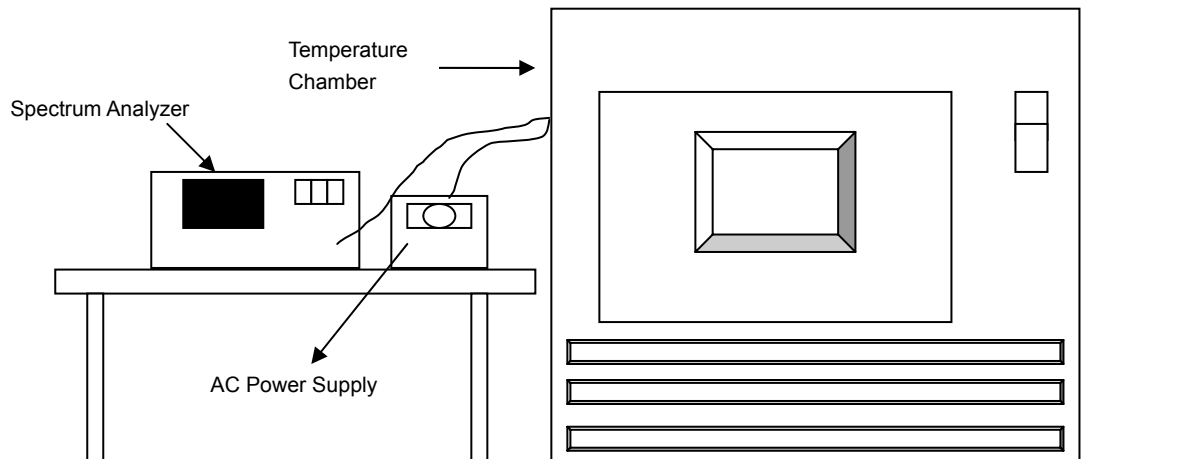

### 4.4.3 Test Instruments

Refer to section 4.1.2 to get information of above instrument.

### 4.4.4 Test Procedure

- The EUT was placed inside the environmental test chamber and powered by nominal AC voltage.
- Turn the EUT on and couple its output to a spectrum analyzer.
- Turn the EUT off and set the chamber to the highest temperature specified.
- Allow sufficient time (approximately 30 min) for the temperature of the chamber to stabilize, turn the EUT on and measure the operating frequency after 2, 5, and 10 minutes.
- Repeat step 2 and 3 with the temperature chamber set to the lowest temperature.
- The test chamber was allowed to stabilize at +20 degree C for a minimum of 30 minutes. The supply voltage was then adjusted on the EUT from 85% to 115% and the frequency record.

### 4.4.5 Deviation from Test Standard

No deviation.

### 4.4.6 EUT Operating Condition

Set the EUT transmit at un-modulation mode to test frequency stability.

**4.4.7 Test Results**

| <b>FREQUENCY STABILITY VERSUS TEMP.</b> |                                   |   |                                    |   |                                    |   |                                    |   |                                    |
|---|-----------------------------------|---|------------------------------------|---|------------------------------------|---|------------------------------------|---|------------------------------------|
| <b>OPERATING FREQUENCY: 5745MHz</b>     |                                   |   |                                    |   |                                    |   |                                    |   |                                    |
| <b>TEMP.<br/>(°C)</b>                   | <b>POWER<br/>SUPPLY<br/>(Vac)</b> | <b>0 MINUTE</b>                         |                                    | <b>2 MINUTE</b>                         |                                    | <b>5 MINUTE</b>                         |                                    | <b>10 MINUTE</b>                        |                                    |
|   |                                   | <b>Measured<br/>Frequency<br/>(MHz)</b> | <b>Frequency<br/>Drift<br/>(%)</b> | <b>Measured<br/>Frequency<br/>(MHz)</b> | <b>Frequency<br/>Drift<br/>(%)</b> | <b>Measured<br/>Frequency<br/>(MHz)</b> | <b>Frequency<br/>Drift<br/>(%)</b> | <b>Measured<br/>Frequency<br/>(MHz)</b> | <b>Frequency<br/>Drift<br/>(%)</b> |
| 50                                      | 120                               | 5744.9999                               | 0.00000                            | 5744.9965                               | -0.00006                           | 5744.9992                               | -0.00001                           | 5744.9999                               | 0.00000                            |
| 40                                      | 120                               | 5745.0301                               | 0.00052                            | 5745.0272                               | 0.00047                            | 5745.0281                               | 0.00049                            | 5745.0249                               | 0.00043                            |
| 30                                      | 120                               | 5744.9759                               | -0.00042                           | 5744.9761                               | -0.00042                           | 5744.9764                               | -0.00041                           | 5744.9799                               | -0.00035                           |
| 20                                      | 120                               | 5744.9775                               | -0.00039                           | 5744.9774                               | -0.00039                           | 5744.9826                               | -0.00030                           | 5744.9782                               | -0.00038                           |
| 10                                      | 120                               | 5744.9891                               | -0.00019                           | 5744.9864                               | -0.00024                           | 5744.9905                               | -0.00017                           | 5744.9888                               | -0.00019                           |
| 0                                       | 120                               | 5745.0139                               | 0.00024                            | 5745.0163                               | 0.00028                            | 5745.0151                               | 0.00026                            | 5745.0172                               | 0.00030                            |
| -10                                     | 120                               | 5745.0118                               | 0.00021                            | 5745.0133                               | 0.00023                            | 5745.0122                               | 0.00021                            | 5745.0127                               | 0.00022                            |
| -20                                     | 120                               | 5744.9971                               | -0.00005                           | 5744.999                                | -0.00002                           | 5744.9962                               | -0.00007                           | 5744.9985                               | -0.00003                           |
| -30                                     | 120                               | 5744.9771                               | -0.00040                           | 5744.9756                               | -0.00042                           | 5744.9758                               | -0.00042                           | 5744.9748                               | -0.00044                           |

| <b>FREQUENCY STABILITY VERSUS VOLTAGE</b> |                                   |   |                                    |   |                                    |   |                                    |   |                                    |
|---|-----------------------------------|---|------------------------------------|---|------------------------------------|---|------------------------------------|---|------------------------------------|
| <b>OPERATING FREQUENCY: 5745MHz</b>       |                                   |   |                                    |   |                                    |   |                                    |   |                                    |
| <b>TEMP.<br/>(°C)</b>                     | <b>POWER<br/>SUPPLY<br/>(Vac)</b> | <b>0 MINUTE</b>                         |                                    | <b>2 MINUTE</b>                         |                                    | <b>5 MINUTE</b>                         |                                    | <b>10 MINUTE</b>                        |                                    |
|   |                                   | <b>Measured<br/>Frequency<br/>(MHz)</b> | <b>Frequency<br/>Drift<br/>(%)</b> | <b>Measured<br/>Frequency<br/>(MHz)</b> | <b>Frequency<br/>Drift<br/>(%)</b> | <b>Measured<br/>Frequency<br/>(MHz)</b> | <b>Frequency<br/>Drift<br/>(%)</b> | <b>Measured<br/>Frequency<br/>(MHz)</b> | <b>Frequency<br/>Drift<br/>(%)</b> |
| 20  | 138                               | 5744.9786                               | -0.00037                           | 5744.9771                               | -0.00040                           | 5744.9828                               | -0.00030                           | 5744.9775                               | -0.00039                           |
|   | 120                               | 5744.9775                               | -0.00039                           | 5744.9774                               | -0.00039                           | 5744.9826                               | -0.00030                           | 5744.9782                               | -0.00038                           |
|   | 102                               | 5744.9765                               | -0.00041                           | 5744.977                                | -0.00040                           | 5744.983                                | -0.00030                           | 5744.9775                               | -0.00039                           |

## 4.5 6dB Bandwidth Measurement

### 4.5.1 Limits of 6dB Bandwidth Measurement

The minimum of 6dB Bandwidth Measurement is 0.5MHz.

### 4.5.2 Test Setup

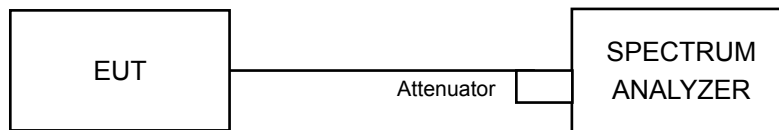

### 4.5.3 Test Instruments

Refer to section 4.1.2 to get information of above instrument.

### 4.5.4 Test Procedure

#### MEASUREMENT PROCEDURE REF

- a. Set resolution bandwidth (RBW) = 100kHz
- b. Set the video bandwidth (VBW)  $\geq 3 \times$  RBW, Detector = Peak.
- c. Trace mode = max hold.
- d. Sweep = auto couple.
- e. Measure the maximum width of the emission that is constrained by the frequencies associated with the two amplitude points (upper and lower) that are attenuated by 6 dB relative to the maximum level measured in the fundamental emission

### 4.5.5 Deviation from Test Standard

No deviation.

### 4.5.6 EUT Operating Condition

The software provided by client to enable the EUT under transmission condition continuously at lowest, middle and highest channel frequencies individually.



### 4.5.7 Test Results

#### CDD Mode

| Channel        | Frequency (MHz) | 6dB Bandwidth (MHz) |         |         | Minimum Limit (MHz) | Pass / Fail |
|----------------|-----------------|---------------------|---------|---------|---------------------|-------------|
|                |                 | Chain 0             | Chain 1 | Chain 2 |                     |             |
| <b>802.11a</b> |                 |                     |         |         |                     |             |
| 149            | 5745            | 16.40               | 16.42   | 16.44   | 0.5                 | Pass        |
| 157            | 5785            | 16.41               | 16.44   | 16.40   | 0.5                 | Pass        |
| 165            | 5825            | 16.40               | 16.45   | 16.44   | 0.5                 | Pass        |

#### CDD Mode

#### SPECTRUM PLOT OF WORST VALUE

#### 802.11a – Chain 0: CH 149

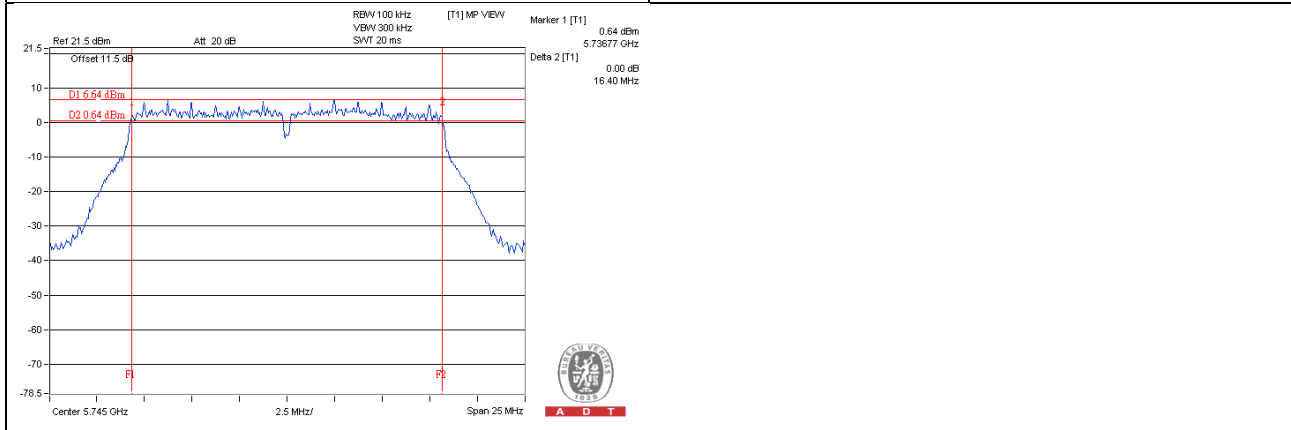

**Beamforming Mode**

| Channel                 | Frequency (MHz) | 6dB Bandwidth (MHz) |         |         | Minimum Limit (MHz) | Pass / Fail |
|-------------------------|-----------------|---------------------|---------|---------|---------------------|-------------|
|                         |                 | Chain 0             | Chain 1 | Chain 2 |                     |             |
| <b>802.11ac (VHT20)</b> |                 |                     |         |         |                     |             |
| 149                     | 5745            | 17.66               | 17.67   | 17.69   | 0.5                 | Pass        |
| 157                     | 5785            | 17.65               | 17.69   | 17.68   | 0.5                 | Pass        |
| 165                     | 5825            | 17.66               | 17.66   | 17.66   | 0.5                 | Pass        |
| <b>802.11ac (VHT40)</b> |                 |                     |         |         |                     |             |
| 151                     | 5755            | 36.45               | 36.47   | 36.46   | 0.5                 | Pass        |
| 159                     | 5795            | 35.98               | 36.43   | 36.45   | 0.5                 | Pass        |
| <b>802.11ac (VHT80)</b> |                 |                     |         |         |                     |             |
| 155                     | 5775            | 75.58               | 76.46   | 76.23   | 0.5                 | Pass        |

**Beamforming Mode**  
**SPECTRUM PLOT OF WORST VALUE**

**802.11ac (VHT20) – Chain 0: CH157**

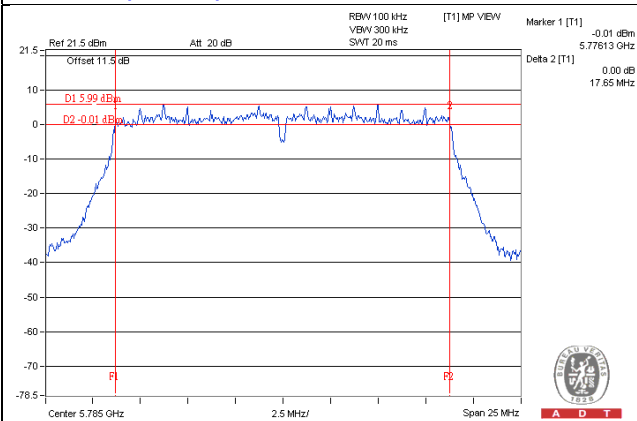

**802.11ac (VHT40) – Chain 1: CH159**

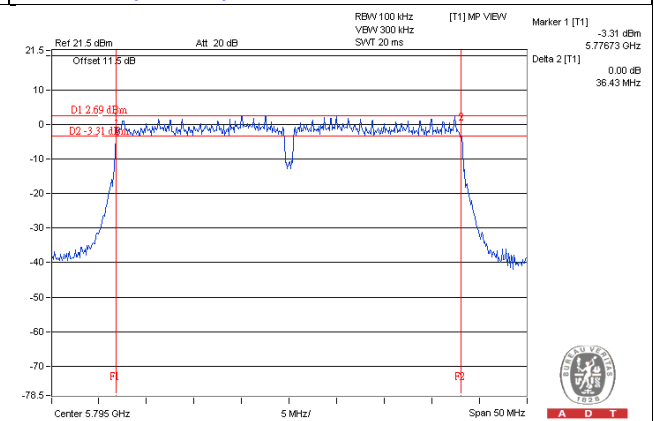

**802.11ac (VHT80) – Chain 0: CH155**

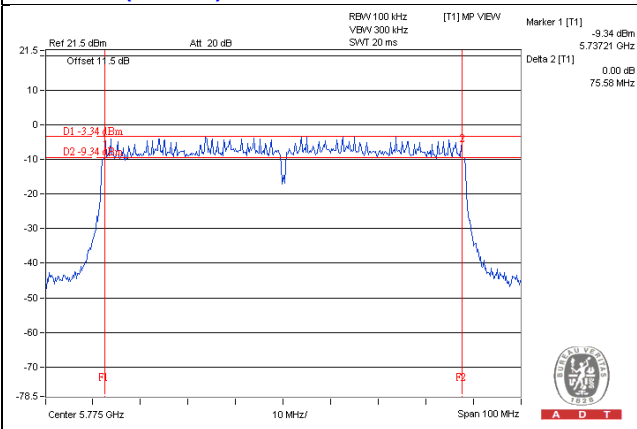

## 5 Pictures of Test Arrangements

Please refer to the attached file (Test Setup Photo).



## Appendix – Information on the Testing Laboratories

We, Bureau Veritas Consumer Products Services (H.K.) Ltd., Taoyuan Branch, were founded in 1988 to provide our best service in EMC, Radio, Telecom and Safety consultation. Our laboratories are accredited and approved according to ISO/IEC 17025.

If you have any comments, please feel free to contact us at the following:

**Linko EMC/RF Lab**

Tel: 886-2-26052180

Fax: 886-2-26051924

**Hsin Chu EMC/RF Lab/Telecom Lab**

Tel: 886-3-5935343

Fax: 886-3-5935342

**Hwa Ya EMC/RF/Safety**

Tel: 886-3-3183232

Fax: 886-3-3270892

**Email:** [service.adt@tw.bureauveritas.com](mailto:service.adt@tw.bureauveritas.com)

**Web Site:** [www.bureauveritas-adt.com](http://www.bureauveritas-adt.com)

The address and road map of all our labs can be found in our web site also.

--- END ---