



FCC TEST REPORT (15.407)

REPORT NO.: RF140710C17-1 R1

MODEL NO.: C6300BD

FCC ID: PY314200260

RECEIVED: July 10, 2014

TESTED: July 22 to 29, 2014

ISSUED: Oct. 15, 2014

APPLICANT: Netgear Inc

ADDRESS: 350 E. Plumeria Drive, San Jose CA 95134,
USA

ISSUED BY: Bureau Veritas Consumer Products Services
(H.K.) Ltd., Taoyuan Branch Hsin Chu Laboratory

LAB ADDRESS : No. 81-1, Lu Liao Keng, 9th Ling, Wu Lung Tsuen,
Chiung Lin Hsiang, Hsin Chu Hsien 307, Taiwan,
R.O.C.

TEST LOCATION (1): No. 81-1, Lu Liao Keng, 9th Ling, Wu Lung Tsuen,
Chiung Lin Hsiang, Hsin Chu Hsien 307, Taiwan,
R.O.C.

TEST LOCATION (2): No. 49, Ln. 206, Wende Rd., Shangshan Tsuen,
Chiung Lin Hsiang, Hsin Chu Hsien 307, Taiwan,
R.O.C.

This report should not be used by the client to claim product certification, approval, or endorsement by TAF or any government agencies.



This report is for your exclusive use. Any copying or replication of this report to or for any other person or entity, or use of our name or trademark, is permitted only with our prior written permission. This report sets forth our findings solely with respect to the test samples identified herein. The results set forth in this report are not indicative or representative of the quality or characteristics of the lot from which a test sample was taken or any similar or identical product unless specifically and expressly noted. Our report includes all of the tests requested by you and the results thereof based upon the information that you provided to us. You have 60 days from date of issuance of this report to notify us of any material error or omission caused by our negligence, provided, however, that such notice shall be in writing and shall specifically address the issue you wish to raise. A failure to raise such issue within the prescribed time shall constitute your unqualified acceptance of the completeness of this report, the tests conducted and the correctness of the report contents. Unless specific mention, the uncertainty of measurement has been explicitly taken into account to declare the compliance or non-compliance to the specification



A D T

Table of Contents

RELEASE CONTROL RECORD	4
1. CERTIFICATION	5
2. SUMMARY OF TEST RESULTS	6
2.1 MEASUREMENT UNCERTAINTY	7
3. GENERAL INFORMATION.....	8
3.1 GENERAL DESCRIPTION OF EUT (WLAN).....	8
3.2 DESCRIPTION OF TEST MODES.....	11
3.2.1 TEST MODE APPLICABILITY AND TESTED CHANNEL DETAIL.....	12
3.3 GENERAL DESCRIPTION OF APPLIED STANDARDS	14
3.4 DUTY CYCLE OF TEST SIGNAL.....	15
3.5 DESCRIPTION OF SUPPORT UNITS	16
3.6 CONFIGURATION OF SYSTEM UNDER TEST	17
4. TEST TYPES AND RESULTS	18
4.1 CONDUCTED EMISSION MEASUREMENT	18
4.1.1 LIMITS OF CONDUCTED EMISSION MEASUREMENT.....	18
4.1.2 TEST INSTRUMENTS	18
4.1.3 TEST PROCEDURES	19
4.1.4 DEVIATION FROM TEST STANDARD	19
4.1.5 TEST SETUP	19
4.1.6 EUT OPERATING CONDITIONS	20
4.1.7 TEST RESULTS (MODE 1).....	21
4.1.8 TEST RESULTS (MODE 2).....	23
4.2 RADIATED EMISSION AND BANDEDGE MEASUREMENT.....	25
4.2.1 LIMITS OF RADIATED EMISSION AND BANDEDGE MEASUREMENT	25
4.2.2 LIMITS OF UNWANTED EMISSION OUT OF THE RESTRICTED BANDS.....	26
4.2.3 TEST INSTRUMENTS	27
4.2.4 TEST PROCEDURES	28
4.2.5 DEVIATION FROM TEST STANDARD	28
4.2.6 TEST SETUP	29
4.2.7 EUT OPERATING CONDITION	29
4.2.8 TEST RESULTS	30
4.3 TRANSMIT POWER MEASUREMENT.....	40
4.3.1 LIMITS OF TRANSMIT POWER MEASUREMENT	40
4.3.2 TEST INSTRUMENTS	41
4.3.3 TEST PROCEDURE	41
4.3.4 DEVIATION FROM TEST STANDARD	42
4.3.5 TEST SETUP	42
4.3.6 EUT OPERATING CONDITIONS.....	42



A D T

4.3.7	TEST RESULTS	43
4.4	PEAK POWER SPECTRAL DENSITY MEASUREMENT	47
4.4.1	LIMITS OF PEAK POWER SPECTRAL DENSITY MEASUREMENT	47
4.4.2	TEST INSTRUMENTS	47
4.4.3	TEST PROCEDURES	48
4.4.4	DEVIATION FROM TEST STANDARD	48
4.4.5	TEST SETUP	48
4.4.6	EUT OPERATING CONDITIONS	48
4.4.7	TEST RESULTS	49
4.5	FREQUENCY STABILITY	52
4.5.1	LIMITS OF FREQUENCY STABILITY MEASUREMENT	52
4.5.2	TEST INSTRUMENTS	52
4.5.3	TEST PROCEDURE	52
4.5.4	DEVIATION FROM TEST STANDARD	53
4.5.5	TEST SETUP	53
4.5.6	EUT OPERATING CONDITION	53
4.5.7	TEST RESULTS	54
5.	PHOTOGRAPHS OF THE TEST CONFIGURATION.....	55
6.	INFORMATION ON THE TESTING LABORATORIES	56
7.	APPENDIX A - MODIFICATIONS RECORDERS FOR ENGINEERING CHANGES TO THE EUT BY THE LAB.....	57



A D T

RELEASE CONTROL RECORD

ISSUE NO.	REASON FOR CHANGE	DATE ISSUED
RF140710C17-1	Original release	Oct. 09, 2014
RF140710C17-1 R1	Remove the FCC Part 15, Subpart B statement	Oct. 15, 2014



A D T

1. CERTIFICATION

PRODUCT: Wireless Cable Data Gateway
BRAND NAME: NETGEAR
MODEL NO.: C6300BD
TEST SAMPLE: ENGINEERING SAMPLE
APPLICANT: Netgear Inc
TESTED: July 22 to 29, 2014
STANDARDS: **FCC Part 15, Subpart E (Section 15.407)**
ANSI C63.10-2009

The above equipment (Model: C6300BD) has been tested by **Bureau Veritas Consumer Products Services (H.K.) Ltd., Taoyuan Branch**, and found compliance with the requirement of the above standards. The test record, data evaluation & Equipment Under Test (EUT) configurations represented herein are true and accurate accounts of the measurements of the sample's EMC characteristics under the conditions specified in this report.

Prepared by :  , **Date:** Oct. 15, 2014
(Claire Kuan, Specialist)

Approved by :  , **Date:** Oct. 15, 2014
(May Chen, Manager)



A D T

2. SUMMARY OF TEST RESULTS

The EUT has been tested according to the following specifications:

APPLIED STANDARD: FCC PART 15, SUBPART E (SECTION 15.407)			
STANDARD SECTION	TEST TYPE	RESULT	REMARK
15.407(b)(6)	AC Power Conducted Emission	PASS	Meet the requirement of limit. Minimum passing margin is -10.61dB at 0.15781MHz
15.407 (b)(1/2/3/4/6)	Radiated Emissions & Band Edge Measurement	PASS	Meet the requirement of limit. Minimum passing margin is -0.1dB at 5788.00MHz.
15.407(a/1/2/3)	Transmit Power	PASS	Meet the requirement of limit.
15.407(a/1/2/3)	Peak Power Spectral Density	PASS	Meet the requirement of limit.
15.407(g)	Frequency Stability	PASS	Meet the requirement of limit.
15.203	Antenna Requirement	PASS	Antenna connector is I-PEX not a standard connector.

NOTE: 1. The EUT was operating in 2400 ~ 2483.5MHz, 5.15~5.25GHz and 5.725~5.850GHz frequencies band. This report was recorded the RF parameters including 5.15~5.25GHz. For the 2400 ~ 2483.5MHz and 5.725~5.850GHz RF parameters was recorded in another test report.



A D T

2.1 MEASUREMENT UNCERTAINTY

Where relevant, the following measurement uncertainty levels have been estimated for tests performed on the EUT as specified in CISPR 16-4-2:

This uncertainty represents an expanded uncertainty expressed at approximately the 95% confidence level using a coverage factor of $k=2$.

Measurement	Value
Conducted emissions	2.86 dB
Radiated emissions (30MHz-1GHz)	5.37 dB
Radiated emissions (1GHz -6GHz)	3.65 dB
Radiated emissions (6GHz -18GHz)	3.88 dB
Radiated emissions (18GHz -40GHz)	4.11 dB



A D T

3. GENERAL INFORMATION

3.1 GENERAL DESCRIPTION OF EUT (WLAN)

PRODUCT	Wireless Cable Data Gateway
MODEL NO.	C6300BD
POWER SUPPLY	DC 12V from power adapter
MODULATION TYPE	CCK, DQPSK, DBPSK for DSSS 64QAM, 16QAM, QPSK, BPSK for OFDM 256QAM for OFDM in 11ac mode only
MODULATION TECHNOLOGY	DSSS,OFDM
TRANSFER RATE	802.11b: up to 11Mbps 802.11a / g: up to 54Mbps 802.11n: up to 450Mbps 802.11ac: up to 1300Mbps
OPERATING FREQUENCY	For 15.407 5.18 ~ 5.24GHz
	For 15.247 2.4GHz: 2412 ~ 2462MHz
	5GHz: 5.745 ~ 5.825GHz
NUMBER OF CHANNEL	For 15.407 4 for 802.11a, 802.11n (HT20), 802.11ac (VHT20) 2 for 802.11n (HT40), 802.11ac (VHT40) 1 for 802.11ac (VHT80)
	For 15.247(2.4GHz) 11 for 802.11b, 802.11g, 802.11n (HT20) 7 for 802.11n (HT40)
	For 15.247(5GHz) 5 for 802.11a, 802.11n (HT20), 802.11ac (VHT20) 2 for 802.11n (HT40), 802.11ac (VHT40) 1 for 802.11ac (VHT80)



MAXIMUM OUTPUT POWER	For 15.407
	802.11a: 221.398mW
	802.11ac (VHT20): 269.654mW
	802.11ac (VHT40): 237.371mW
	802.11ac (VHT80): 86.452mW
	For 15.247(2.4GHz)
	802.11b: 683.701mW
	802.11g: 661.388mW
	802.11n (HT20): 476.954mW
	802.11n (HT40): 200.838mW
MAXIMUM OUTPUT POWER	For 15.247(5GHz)
	802.11a: 829.037mW
	802.11ac (VHT20): 831.402mW
	802.11ac (VHT40): 814.961mW
802.11ac (VHT80): 526.577mW	
ANTENNA TYPE	Please see NOTE
DATA CABLE	NA
I/O PORTS	Refer to user's manual
ASSOCIATED DEVICES	Adapter x 1

NOTE:

1. The antennas provided to the EUT, please refer to the following table:

For 2.4G used						
Ant. No.	Transmitter Circuit	Brand	Model	Antenna Type	Antenna Gain (dBi)	Connector type
1	Chain (0)	Master Wave	98P92UIPF030	PCB	2	I-PEX
2	Chain (1)		98P92UIPF031		2	
3	Chain (2)		98P92UIPF033		2	
For 5G used						
Ant. No.	Transmitter Circuit	Brand	Model	Antenna Type	Antenna Gain (dBi)	Connector type
4	Chain (0)	Master Wave	98P92UIPF033	PCB	2	I-PEX
5	Chain (1)		98P92UIPF034		2	
6	Chain (2)		98P92UIPF034		2	

2. The EUT could be supplied with a power adapter as the following table:

Adapter No.:	Brand	Model No.	Spec.
1	Netgear	2AAF042F	AC I/P: 100-240V, 1.5A, 50/60Hz DC O/P: 12V, 3.5A DC output cable (Unshielded, 1.8m)
2	Netgear	AD898F20	AC I/P: 100-240V, 1A, 50/60Hz DC O/P: 12V, 3.5A DC output cable (Unshielded, 1.8m)

Note: From the above adapters, the worst radiated test was found in **Adapter 1**. Therefore only the test data of the modes were recorded in this report.

3. The EUT incorporates a MIMO function with beamforming.

MODULATION MODE	DATA RATE (MCS)	TX/RX FUNCTION	
802.11a	6 ~ 54Mbps	3TX (CDD Mode)	3RX
802.11b	1 ~ 11Mbps	3TX (CDD Mode)	3RX
802.11g	6 ~ 54Mbps	3TX (CDD Mode)	3RX
802.11n (HT20) & 802.11n (HT40)	MCS 0~7	3TX (CDD Mode)	3RX
	MCS 8~15	3TX	3RX
	MCS 16~23	3TX	3RX
802.11ac (VHT20)	MCS0~8 Nss= 1	3TX (CDD Mode)	3RX
	MCS0~8 Nss= 2	3TX (CDD Mode)	3RX
	MCS0~9 Nss= 3	3TX	3RX
802.11ac (VHT40) & 802.11ac (VHT80)	MCS0~9 Nss= 1	3TX (CDD Mode)	3RX
	MCS0~9 Nss= 2	3TX (CDD Mode)	3RX
	MCS0~9 Nss= 3	3TX / 3RX	3RX

Note: The modulation and bandwidth are similar for 802.11n mode for 20MHz (40MHz) and 802.11ac mode for 20MHz (40MHz), therefore investigated worst case to representative mode in test report. (Final test mode refer section 3.2.1)

4. The emission of the simultaneous operation (2.4GHz & 5GHz) has been evaluated and no non-compliance was found.
5. The above EUT information was declared by manufacturer and for more detailed features description, please refer to the manufacturer's specifications or user's manual.



A D T

3.2 DESCRIPTION OF TEST MODES

4 channels are provided for 802.11a, 802.11n (HT20), 802.11ac (VHT20):

CHANNEL	FREQUENCY	CHANNEL	FREQUENCY
36	5180 MHz	44	5220 MHz
40	5200 MHz	48	5240 MHz

2 channels are provided for 802.11n (HT40), 802.11ac (VHT40):

CHANNEL	FREQUENCY	CHANNEL	FREQUENCY
38	5190 MHz	46	5230 MHz

1 channel is provided for 802.11ac (VHT80):

CHANNEL	FREQUENCY
42	5210 MHz



A D T

3.2.1 TEST MODE APPLICABILITY AND TESTED CHANNEL DETAIL

EUT CONFIGURE MODE	APPLICABLE TO				DESCRIPTION
	PLC	RE < 1G	RE ≥ 1G	APCM	
1	√	√	√	√	Adapter No.: 1
2	√	-	-	-	Adapter No.: 2

Where **PLC**: Power Line Conducted Emission **RE < 1G**: Radiated Emission below 1GHz
RE ≥ 1G: Radiated Emission above 1GHz **APCM**: Antenna Port Conducted Measurement

NOTE: 1. The EUT had been pre-tested on the positioned of each 2 axis. The worst case was found when positioned on **Y-plane**.

POWER LINE CONDUCTED EMISSION TEST:

- Pre-Scan has been conducted to determine the worst-case mode from all possible combinations between available modulations, data rates and antenna ports (if EUT with antenna diversity architecture).
- Following channel(s) was (were) selected for the final test as listed below.

MODE	AVAILABLE CHANNEL	TESTED CHANNEL	MODULATION TECHNOLOGY	MODULATION TYPE	DATA RATE (MBPS)
802.11ac (VHT20)	36 to 48	48	OFDM	BPSK	6.5

RADIATED EMISSION TEST (BELOW 1 GHz):

- Pre-Scan has been conducted to determine the worst-case mode from all possible combinations between available modulations, data rates and antenna ports (if EUT with antenna diversity architecture).
- Following channel(s) was (were) selected for the final test as listed below.

MODE	AVAILABLE CHANNEL	TESTED CHANNEL	MODULATION TECHNOLOGY	MODULATION TYPE	DATA RATE (Mbps)
802.11ac (VHT20)	36 to 48	48	OFDM	BPSK	6.5



RADIATED EMISSION TEST (ABOVE 1 GHz):

- Pre-Scan has been conducted to determine the worst-case mode from all possible combinations between available modulations, data rates and antenna ports (if EUT with antenna diversity architecture).
- Following channel(s) was (were) selected for the final test as listed below.

MODE	AVAILABLE CHANNEL	TESTED CHANNEL	MODULATION TECHNOLOGY	MODULATI ON TYPE	DATA RATE (Mbps)
802.11a	36 to 48	36, 40, 48	OFDM	BPSK	6
802.11ac (VHT20)	36 to 48	36, 40, 48	OFDM	BPSK	6.5
802.11ac (VHT40)	38 to 46	38, 46	OFDM	BPSK	13.5
802.11ac (VHT80)	42	42	OFDM	BPSK	29.3

ANTENNA PORT CONDUCTED MEASUREMENT:

- Pre-Scan has been conducted to determine the worst-case mode from all possible combinations between available modulations, data rates and antenna ports (if EUT with antenna diversity architecture).
- Following channel(s) was (were) selected for the final test as listed below.

MODE	AVAILABLE CHANNEL	TESTED CHANNEL	MODULATION TECHNOLOGY	MODULATI ON TYPE	DATA RATE (Mbps)
802.11a	36 to 48	36, 40, 48	OFDM	BPSK	6
802.11ac (VHT20)	36 to 48	36, 40, 48	OFDM	BPSK	6.5
802.11ac (VHT40)	38 to 46	38, 46	OFDM	BPSK	13.5
802.11ac (VHT80)	42	42	OFDM	BPSK	29.3

TEST CONDITION:

APPLICABLE TO	ENVIRONMENTAL CONDITIONS	INPUT POWER	TESTED BY
PLC	30deg. C, 70%RH	120Vac, 60Hz	Mike Hsieh
RE<1G	25deg. C, 73%RH	120Vac, 60Hz	Gary Cheng
RE≥1G	28deg. C, 76%RH	120Vac, 60Hz	Gary Cheng
APCM	25deg. C, 60%RH	120Vac, 60Hz	Robert Cheng



3.3 GENERAL DESCRIPTION OF APPLIED STANDARDS

The EUT is a RF product. According to the specifications of the manufacturer, it must comply with the requirements of the following standards:

FCC Part 15, Subpart E (15.407)

789033 D02 General UNII Test Procedures New Rules v01

662911 D01 Multiple Transmitter Output v02r01

ANSI C63.10-2009

All test items have been performed and recorded as per the above standards.



A D T

3.4 DUTY CYCLE OF TEST SIGNAL

If duty cycle of test signal is $\geq 98\%$, duty factor is not required.

If duty cycle of test signal is $< 98\%$, duty factor shall be considered.

802.11a: Duty cycle = 2.055 ms/2.078 ms = 0.989

802.11ac (VHT20): Duty cycle = 1.924 ms/1.953 ms = 0.985

802.11ac (VHT40): Duty cycle = 0.944 ms/0.969 ms = 0.974, Duty factor = $10 * \log(1/0.974) = 0.1$

802.11ac (VHT80): Duty cycle = 0.459 ms/0.479 ms = 0.958, Duty factor = $10 * \log(1/0.958) = 0.2$

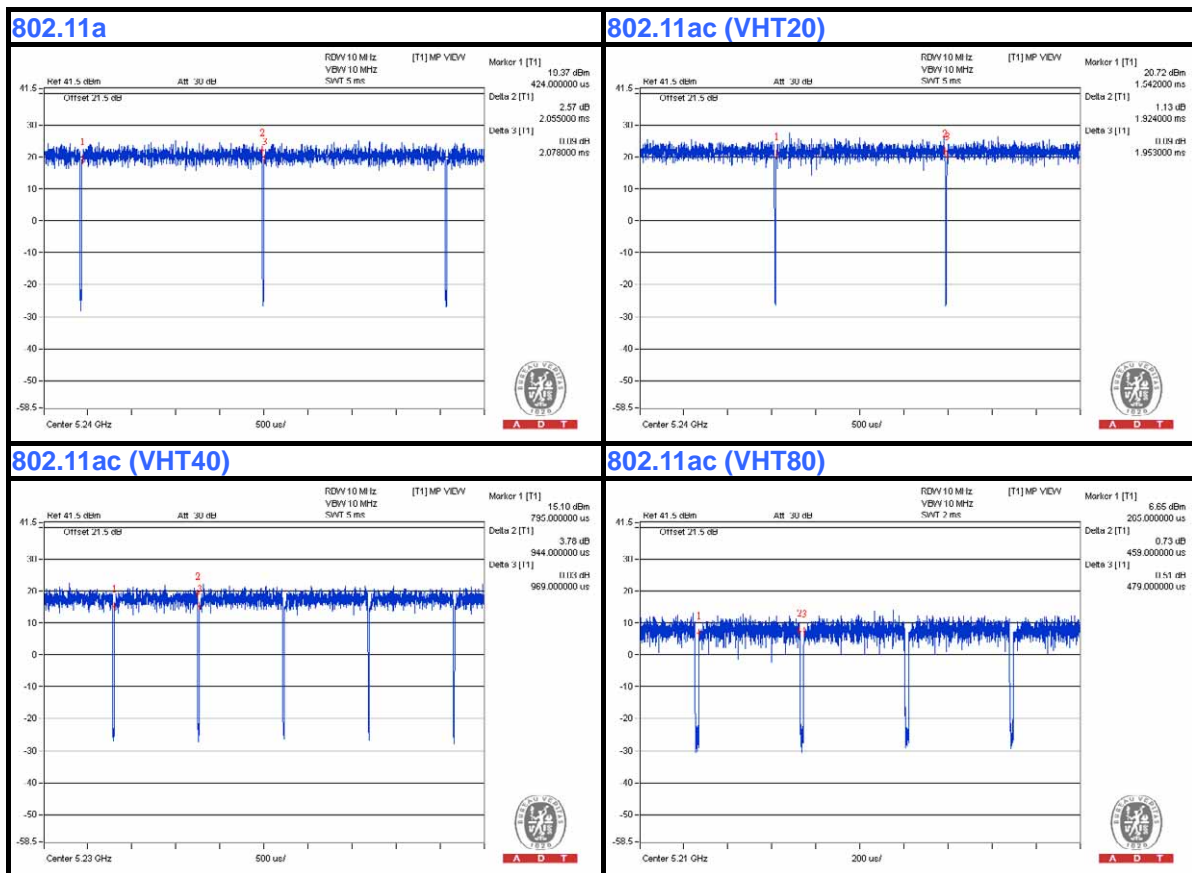



A D T

3.5 DESCRIPTION OF SUPPORT UNITS

The EUT has been tested as an independent unit together with other necessary accessories or support units. The following support units or accessories were used to form a representative test configuration during the tests.

No.	Product	Brand	Model No.	Serial No.	FCC ID	Remark
A	HDD	WD	WDBACW0010 HBK-SESN	WCAZAL625787	FCC DoC	Provided by Lab
B	HUB	ZyXEL	ES-116P	S060H02000215	FCC DoC	Provided by Lab
C	NOTEBOOK COMPUTER	DELL	PP32LA	GSLB32S	FCC DoC	Provided by Lab

NOTE:

1. All power cords of the above support units are non-shielded (1.8 m).

No.	Cable	Qty.	Length (m)	Shielded (Yes/ No)	Cores (Number)	Remark
1	DC cable	1	1.8	No	0	Supplied by client
2	USB Cable	1	1.8	Yes	0	Provided by Lab
3	UTP RJ45	3	10	No	0	Provided by Lab
4	UTP RJ45	1	10	No	0	Provided by Lab
5	Coaxial Cable	1	10	No	0	Provided by Lab

3.6 CONFIGURATION OF SYSTEM UNDER TEST

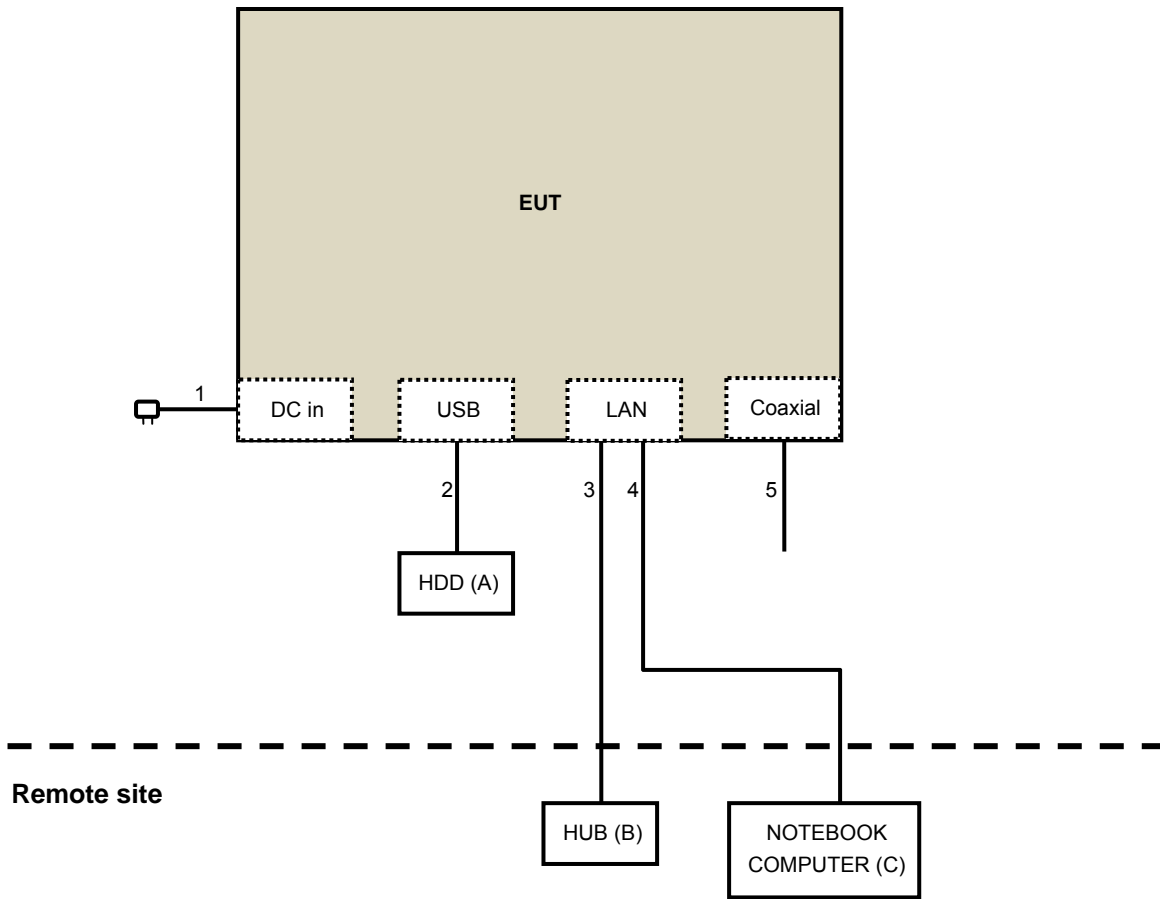



A D T

4. TEST TYPES AND RESULTS

4.1 CONDUCTED EMISSION MEASUREMENT

4.1.1 LIMITS OF CONDUCTED EMISSION MEASUREMENT

FREQUENCY OF EMISSION (MHz)	CONDUCTED LIMIT (dB μ V)	
	Quasi-peak	Average
0.15-0.5	66 to 56	56 to 46
0.5-5	56	46
5-30	60	50

- NOTE:**
1. The lower limit shall apply at the transition frequencies.
 2. The limit decreases in line with the logarithm of the frequency in the range of 0.15 to 0.50 MHz.

4.1.2 TEST INSTRUMENTS

DESCRIPTION & MANUFACTURER	MODEL NO.	SERIAL NO.	CALIBRATED DATE	CALIBRATED UNTIL
Test Receiver ROHDE & SCHWARZ	ESCS 30	100375	Apr. 29, 2014	Apr. 28, 2015
Line-Impedance Stabilization Network (for EUT) SCHWARZBECK	NSLK8127	8127-522	Sep. 12, 2013	Sep. 11, 2014
Line-Impedance Stabilization Network (for Peripheral)	ENV216	100071	Nov. 13, 2013	Nov. 12, 2014
RF Cable (JYBAO)	5DFB	COCCAB-001	Mar. 10, 2014	Mar. 09, 2015
50 ohms Terminator	N/A	EMC-03	Sep. 24, 2013	Sep. 23, 2014
50 ohms Terminator	N/A	EMC-02	Oct. 01, 2013	Sep. 30, 2014
Software ADT	BV ADT_Cond_V7.3.7. 3	NA	NA	NA

Note:

1. The calibration interval of the above test instruments is 12 months and the calibrations are traceable to NML/ROC and NIST/USA.
2. The test was performed in Shielded Room No. C.
- 3 The VCCI Con C Registration No. is C-3611.
- 4 Tested Date: July 22, 2014

4.1.3 TEST PROCEDURES

- a. The EUT was placed 0.4 meters from the conducting wall of the shielded room with EUT being connected to the power mains through a line impedance stabilization network (LISN). Other support units were connected to the power mains through another LISN.
- b. The two LISNs provide 50 ohm/ 50uH of coupling impedance for the measuring instrument.
- c. Both lines of the power mains connected to the EUT were checked for maximum conducted interference.
- d. The frequency range from 150kHz to 30MHz was searched. Emission level under (Limit – 20dB) was not recorded.

NOTE:

1. The resolution bandwidth of test receiver is 9kHz for Quasi-peak detection (QP) & Average detection (AV).

4.1.4 DEVIATION FROM TEST STANDARD

No deviation

4.1.5 TEST SETUP

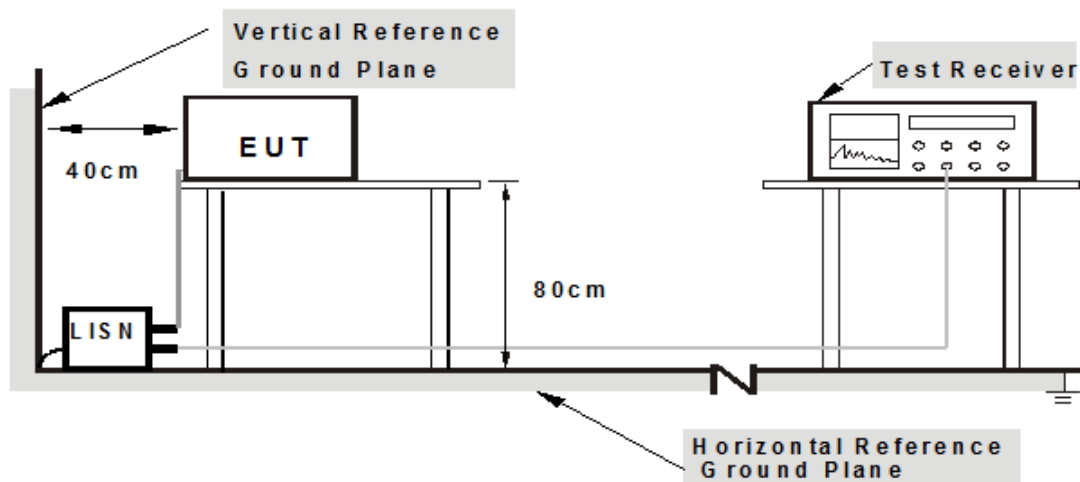

Note: 1. Support units were connected to second LISN.

For the actual test configuration, please refer to the related item – Photographs of the Test Configuration.



A D T

4.1.6 EUT OPERATING CONDITIONS

1. Connect the EUT with the support unit C (Notebook Computer) which is placed on table in remote site.
2. The communication partner run test program “Mtool 2.0.1.1” to enable EUT under transmission/receiving condition continuously at specific channel frequency.

4.1.7 TEST RESULTS (MODE 1)

PHASE	Line (L)	DETECTOR FUNCTION	Quasi-Peak (QP) / Average (AV)
--------------	----------	--------------------------	--------------------------------

No	Freq. [MHz]	Corr. Factor [dB]	Reading Value [dB (uV)]		Emission Level [dB (uV)]		Limit [dB (uV)]		Margin (dB)	
			Q.P.	AV.	Q.P.	AV.	Q.P.	AV.	Q.P.	AV.
1	0.16671	0.07	52.11	41.54	52.18	41.61	65.12	55.12	-12.95	-13.52
2	0.19687	0.07	41.57	15.57	41.64	15.64	63.74	53.74	-22.10	-38.10
3	0.31406	0.08	31.40	9.11	31.48	9.19	59.86	49.86	-28.38	-40.67
4	0.50938	0.10	35.79	30.80	35.89	30.90	56.00	46.00	-20.11	-15.10
5	1.97266	0.17	29.82	23.24	29.99	23.41	56.00	46.00	-26.01	-22.59
6	18.65234	0.68	30.82	24.15	31.50	24.83	60.00	50.00	-28.50	-25.17

REMARKS:

1. Q.P. and AV. are abbreviations of quasi-peak and average individually.
2. The emission levels of other frequencies were very low against the limit.
3. Margin value = Emission Level – Limit value
4. Correction Factor = Insertion loss + Cable loss
5. Emission Level = Correction Factor + Reading Value

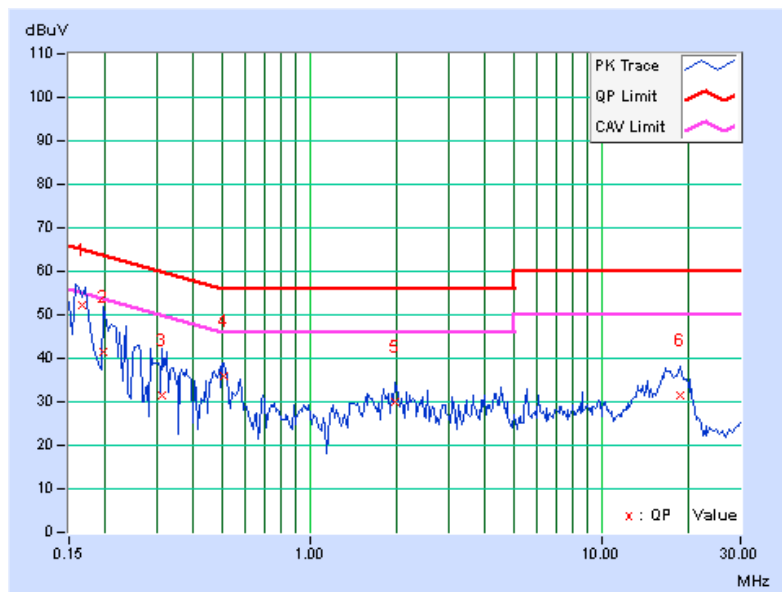



A D T

PHASE	Neutral (N)	DETECTOR FUNCTION	Quasi-Peak (QP) / Average (AV)
-------	-------------	-------------------	--------------------------------

No	Freq.	Corr.	Reading Value		Emission Level		Limit		Margin	
	[MHz]	(dB)	Q.P.	AV.	Q.P.	AV.	Q.P.	AV.	Q.P.	AV.
1	0.16953	0.07	51.16	42.07	51.23	42.14	64.98	54.98	-13.75	-12.84
2	0.22031	0.07	41.09	27.75	41.16	27.82	62.81	52.81	-21.65	-24.99
3	0.30232	0.08	35.22	25.67	35.30	25.75	60.18	50.18	-24.88	-24.43
4	0.59141	0.10	27.86	18.28	27.96	18.38	56.00	46.00	-28.04	-27.62
5	2.01172	0.18	31.08	23.54	31.26	23.72	56.00	46.00	-24.74	-22.28
6	17.04688	0.63	30.20	22.84	30.83	23.47	60.00	50.00	-29.17	-26.53

REMARKS:

1. Q.P. and AV. are abbreviations of quasi-peak and average individually.
2. The emission levels of other frequencies were very low against the limit.
3. Margin value = Emission Level – Limit value
4. Correction Factor = Insertion loss + Cable loss
5. Emission Level = Correction Factor + Reading Value

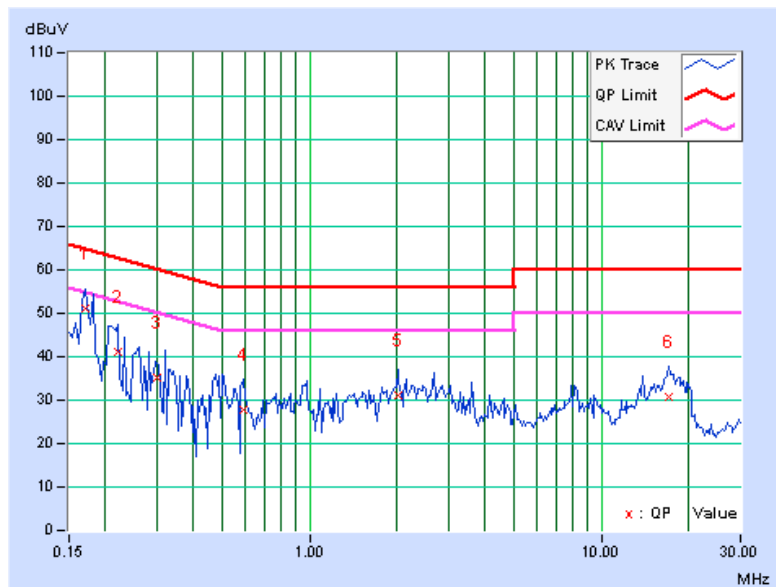



A D T

4.1.8 TEST RESULTS (MODE 2)

PHASE	Line (L)	DETECTOR FUNCTION	Quasi-Peak (QP) / Average (AV)
--------------	----------	--------------------------	--------------------------------

No	Freq. [MHz]	Corr. Factor [dB]	Reading Value [dB (uV)]		Emission Level [dB (uV)]		Limit [dB (uV)]		Margin (dB)	
			Q.P.	AV.	Q.P.	AV.	Q.P.	AV.	Q.P.	AV.
1	0.15781	0.07	52.96	44.90	53.03	44.97	65.58	55.58	-12.55	-10.61
2	0.19687	0.07	46.42	37.95	46.49	38.02	63.74	53.74	-17.25	-15.72
3	0.54844	0.10	36.62	33.89	36.72	33.99	56.00	46.00	-19.28	-12.01
4	3.92969	0.26	35.54	27.62	35.80	27.88	56.00	46.00	-20.20	-18.12
5	8.63281	0.41	33.35	28.26	33.76	28.67	60.00	50.00	-26.24	-21.33
6	11.49609	0.49	39.71	34.74	40.20	35.23	60.00	50.00	-19.80	-14.77

REMARKS:

1. Q.P. and AV. are abbreviations of quasi-peak and average individually.
2. The emission levels of other frequencies were very low against the limit.
3. Margin value = Emission Level – Limit value
4. Correction Factor = Insertion loss + Cable loss
5. Emission Level = Correction Factor + Reading Value

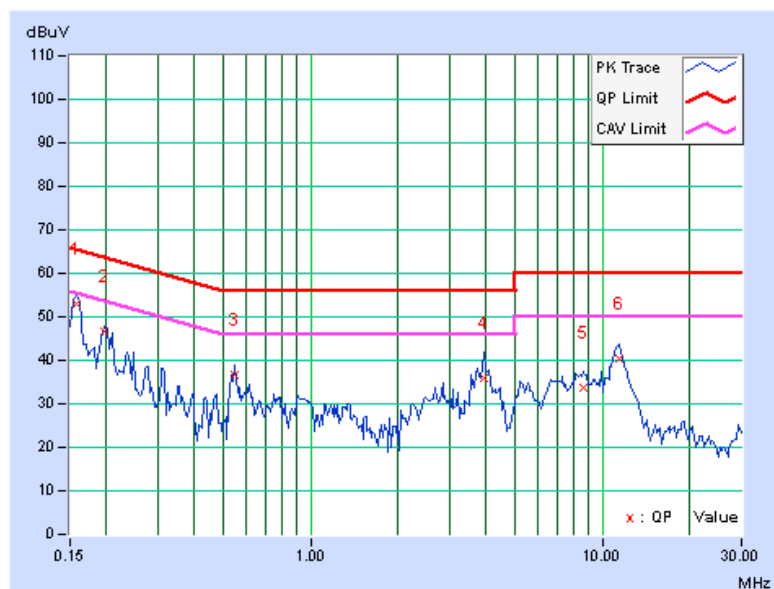



A D T

PHASE	Neutral (N)	DETECTOR FUNCTION	Quasi-Peak (QP) / Average (AV)
--------------	-------------	--------------------------	--------------------------------

No	Freq. [MHz]	Corr. Factor [dB]	Reading Value [dB (uV)]		Emission Level [dB (uV)]		Limit [dB (uV)]		Margin (dB)	
			Q.P.	AV.	Q.P.	AV.	Q.P.	AV.	Q.P.	AV.
1	0.15775	0.07	51.91	44.53	51.98	44.60	65.58	55.58	-13.60	-10.98
2	0.19687	0.07	45.05	37.04	45.12	37.11	63.74	53.74	-18.62	-16.63
3	0.54844	0.10	36.42	32.55	36.52	32.65	56.00	46.00	-19.48	-13.35
4	3.92578	0.26	36.48	27.51	36.74	27.77	56.00	46.00	-19.26	-18.23
5	8.38672	0.40	33.37	28.46	33.77	28.86	60.00	50.00	-26.23	-21.14
6	11.11328	0.48	39.54	34.36	40.02	34.84	60.00	50.00	-19.98	-15.16

REMARKS:

1. Q.P. and AV. are abbreviations of quasi-peak and average individually.
2. The emission levels of other frequencies were very low against the limit.
3. Margin value = Emission Level – Limit value
4. Correction Factor = Insertion loss + Cable loss
5. Emission Level = Correction Factor + Reading Value

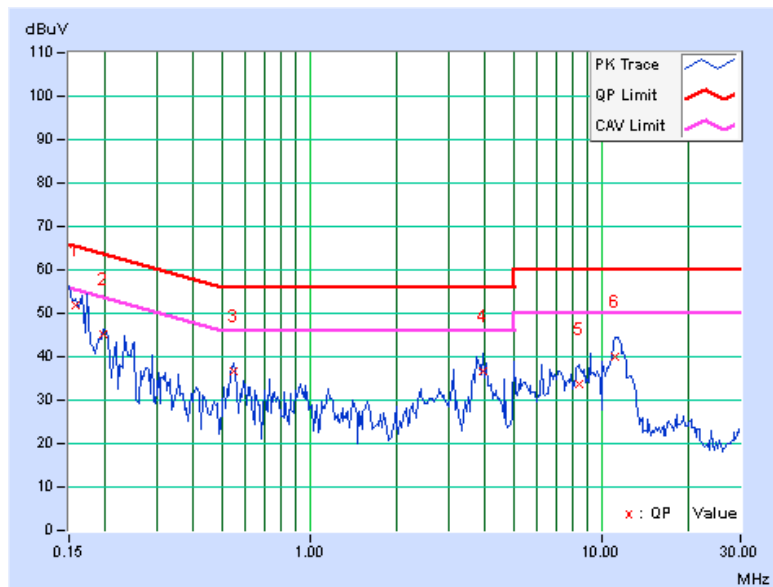



A D T

4.2 RADIATED EMISSION AND BANDEDGE MEASUREMENT

4.2.1 LIMITS OF RADIATED EMISSION AND BANDEDGE MEASUREMENT

Radiated emissions which fall in the restricted bands must comply with the radiated emission limits specified as below table:

Frequencies (MHz)	Field strength (microvolts/meter)	Measurement distance (meters)
0.009-0.490	2400/F(kHz)	300
0.490-1.705	24000/F(kHz)	30
1.705-30.0	30	30
30-88	100	3
88-216	150	3
216-960	200	3
Above 960	500	3

NOTE:

1. The lower limit shall apply at the transition frequencies.
2. Emission level (dBuV/m) = 20 log Emission level (uV/m).
3. For frequencies above 1000MHz, the field strength limits are based on average detector, however, the peak field strength of any emission shall not exceed the maximum permitted average limits, specified above by more than 20dB under any condition of modulation.



4.2.2 LIMITS OF UNWANTED EMISSION OUT OF THE RESTRICTED BANDS

APPLICABLE TO	LIMIT	
789033 D02 General UNII Test Procedures New Rules v01	FIELD STRENGTH AT 3m	
	PK:74 (dBµV/m)	AV:54 (dBµV/m)
APPLICABLE TO	EIRP LIMIT	EQUIVALENT FIELD STRENGTH AT 3m
15.407(b)(1)	PK:-27 (dBm/MHz)	PK:68.2(dBµV/m)
15.407(b)(2)		
15.407(b)(3)		
15.407(b)(4)	PK:-27 (dBm/MHz) ^{*1} PK:-17 (dBm/MHz) ^{*2}	PK: 68.2(dBµV/m) ^{*1} PK:78.2 (dBµV/m) ^{*2}

NOTE: ^{*1} beyond 10MHz of the band edge ^{*2} within 10 MHz of band edge

The following formula is used to convert the equipment isotropic radiated power (eirp) to field strength:

$$E = \frac{1000000\sqrt{30P}}{3} \quad \mu\text{V/m, where P is the eirp (Watts).$$



A D T

4.2.3 TEST INSTRUMENTS

DESCRIPTION & MANUFACTURER	MODEL NO.	SERIAL NO.	CALIBRATED DATE	CALIBRATED UNTIL
MXE EMI Receiver Agilent	N9038A	MY51210105	July 21, 2014	July 20,2015
Pre-Amplifier Mini-Circuits	ZFL-1000VH2 B	AMP-ZFL-03	Nov. 13, 2013	Nov. 12, 2014
Trilog Broadband Antenna SCHWARZBECK	VULB 9168	9168-360	Feb. 26, 2014	Feb. 25, 2015
RF Cable	NA	CHGCAB_001	Oct. 05, 2013	Oct. 04, 2014
Spectrum Analyzer R&S	FSV40	100964	July 05, 2014	July 04, 2015
Horn_Antenna AISI	AIH.8018	0000320091110	Nov. 18, 2013	Nov. 17, 2014
Pre-Amplifier Agilent	8449B	3008A02578	June 24, 2014	June 23, 2015
RF Cable	NA	RF104-201 RF104-203 RF104-204	Dec. 12, 2013	Dec. 11, 2014
Spectrum Analyzer Agilent	E4446A	MY48250253	Aug. 28, 2013	Aug. 27, 2014
Pre-Amplifier SPACEK LABS	SLKKa-48-6	9K16	Nov. 13, 2013	Nov. 12, 2014
Horn_Antenna SCHWARZBECK	BBHA 9170	9170-424	Oct. 08, 2013	Oct. 07, 2014
Software	ADT_Radiated _V8.7.07	NA	NA	NA
Antenna Tower & Turn Table CT	NA	NA	NA	NA

Note:

1. The calibration interval of the above test instruments is 12 months and the calibrations are traceable to NML/ROC and NIST/USA.
2. The horn antenna, preamplifier (model: 8449B) are used only for the measurement of emission frequency above 1GHz if tested.
- 3 The test was performed in 966 Chamber No. G.
4. The FCC Site Registration No. is 966073.
- 5 The VCCI Site Registration No. is G-137.
- 6 The CANADA Site Registration No. is IC 7450H-2.
- 7 Tested Date: July 22, 2014

4.2.4 TEST PROCEDURES

- a. The EUT was placed on the top of a rotating table 0.8 meters above the ground at 3 meter chamber room for test. The table was rotated 360 degrees to determine the position of the highest radiation.
- b. The EUT was set 3 meters away from the interference-receiving antenna, which was mounted on the top of a variable-height antenna tower.
- c. The height of antenna is varied from one meter to four meters above the ground to determine the maximum value of the field strength. Both horizontal and vertical polarizations of the antenna are set to make the measurement.
- d. For each suspected emission, the EUT was arranged to its worst case and then the antenna was tuned to heights from 1 meter to 4 meters and the rotatable table was turned from 0 degrees to 360 degrees to find the maximum reading.
- e. The test-receiver system was set to quasi-peak detect function and specified bandwidth with maximum hold mode when the test frequency is below 1 GHz.
- f. The test-receiver system was set to peak and average detect function and specified bandwidth with maximum hold mode when the test frequency is above 1 GHz. If the peak reading value also meets average limit, measurement with the average detector is unnecessary.

Note:

1. The resolution bandwidth and video bandwidth of test receiver/spectrum analyzer is 120kHz for Quasi-peak detection (QP) at frequency below 1GHz.
2. The resolution bandwidth of test receiver/spectrum analyzer is 1 MHz and the video bandwidth is 3 MHz for Peak detection (PK) at frequency above 1GHz.
3. The resolution bandwidth of test receiver/spectrum analyzer is 1MHz and the video bandwidth is 3MHz for RMS Average (Duty cycle < 98%) for Average detection (AV) at frequency above 1GHz, then the measurement results was added to a correction factor ($10 \log(1/\text{duty cycle})$).
4. The resolution bandwidth of test receiver/spectrum analyzer is 1MHz and the video bandwidth is 10Hz (Duty cycle $\geq 98\%$) for Average detection (AV) at frequency above 1GHz.
5. All modes of operation were investigated and the worst-case emissions are reported.

4.2.5 DEVIATION FROM TEST STANDARD

No deviation

4.2.6 TEST SETUP

<Frequency Range below 1GHz>

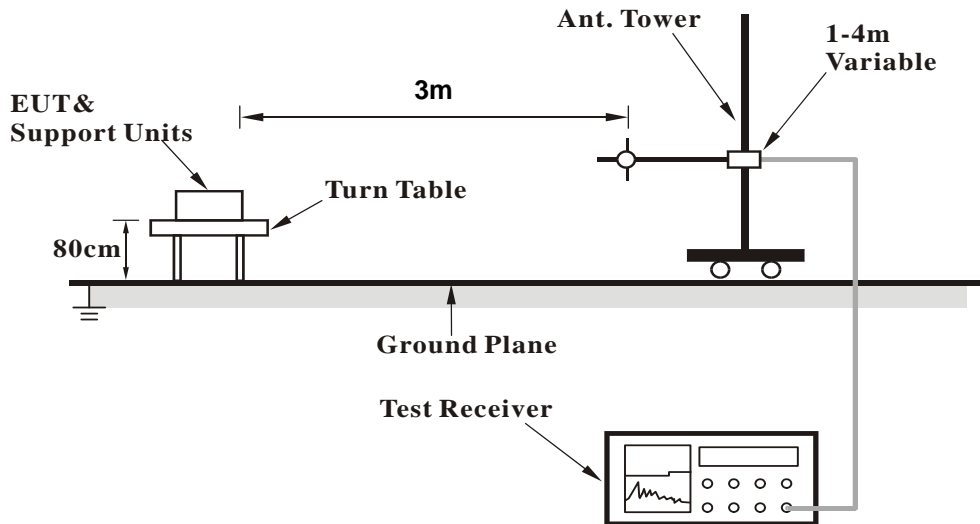

<Frequency Range above 1GHz>

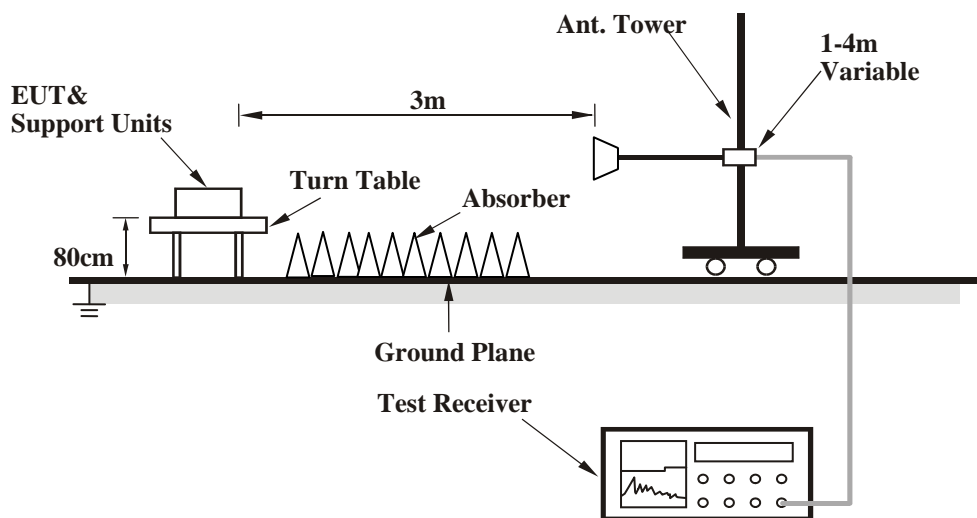

For the actual test configuration, please refer to the related item – Photographs of the Test Configuration.

4.2.7 EUT OPERATING CONDITION

Same as 4.1.6



A D T

4.2.8 TEST RESULTS

BELOW 1GHz WORST-CASE DATA

802.11ac (VHT20)

CHANNEL	TX Channel 48	DETECTOR FUNCTION	Quasi-Peak (QP)
FREQUENCY RANGE	Below 1GHz		

ANTENNA POLARITY & TEST DISTANCE: HORIZONTAL AT 3 M								
NO.	FREQ. (MHz)	EMISSION LEVEL (dBuV/m)	LIMIT (dBuV/m)	MARGIN (dB)	ANTENNA HEIGHT (m)	TABLE ANGLE (Degree)	RAW VALUE (dBuV)	CORRECTION FACTOR (dB/m)
1	125.01	38.5 QP	43.5	-5.0	2.00 H	226	53.46	-14.92
2	250.00	35.0 QP	46.0	-11.0	1.00 H	314	49.34	-14.32
3	258.92	39.4 QP	46.0	-6.6	1.50 H	21	53.34	-13.97
4	375.03	37.3 QP	46.0	-8.7	1.00 H	310	47.52	-10.23
5	749.98	40.2 QP	46.0	-5.8	1.50 H	249	42.13	-1.94
6	875.02	38.9 QP	46.0	-7.1	1.50 H	228	39.31	-0.45
ANTENNA POLARITY & TEST DISTANCE: VERTICAL AT 3 M								
NO.	FREQ. (MHz)	EMISSION LEVEL (dBuV/m)	LIMIT (dBuV/m)	MARGIN (dB)	ANTENNA HEIGHT (m)	TABLE ANGLE (Degree)	RAW VALUE (dBuV)	CORRECTION FACTOR (dB/m)
1	49.19	36.9 QP	40.0	-3.1	1.00 V	98	50.41	-13.51
2	57.55	36.5 QP	40.0	-3.6	1.00 V	360	50.26	-13.81
3	125.01	37.1 QP	43.5	-6.4	1.00 V	96	52.03	-14.92
4	374.98	34.2 QP	46.0	-11.8	1.50 V	257	44.43	-10.24
5	500.01	37.0 QP	46.0	-9.1	1.00 V	266	44.31	-7.36
6	625.00	36.6 QP	46.0	-9.4	1.50 V	237	41.02	-4.41

REMARKS:

1. Emission Level(dBuV/m) = Raw Value(dBuV) + Correction Factor(dB/m)
2. Correction Factor(dB/m) = Antenna Factor(dB/m) + Cable Factor(dB) – Pre-Amplifier Factor(dB)
3. The other emission levels were very low against the limit.
4. Margin value = Emission Level – Limit value



A D T

ABOVE 1GHz DATA

802.11a

CHANNEL	TX Channel 36	DETECTOR FUNCTION	Peak (PK)
FREQUENCY RANGE	1GHz ~ 40GHz		Average (AV)

ANTENNA POLARITY & TEST DISTANCE: HORIZONTAL AT 3 M

NO.	FREQ. (MHz)	EMISSION LEVEL (dBuV/m)	LIMIT (dBuV/m)	MARGIN (dB)	ANTENNA HEIGHT (m)	TABLE ANGLE (Degree)	RAW VALUE (dBuV)	CORRECTION FACTOR (dB/m)
1	5100.00	63.2 PK	74.0	-10.8	1.00 H	290	57.06	6.14
2	5100.00	51.1 AV	54.0	-2.9	1.00 H	290	44.96	6.14
3	*5180.00	112.4 PK			1.00 H	290	105.92	6.48
4	*5180.00	102.1 AV			1.00 H	290	95.62	6.48
5	#10360.00	56.4 PK	74.0	-17.6	1.24 H	102	43.92	12.48
6	#10360.00	44.1 AV	54.0	-9.9	1.24 H	102	31.62	12.48
7	15540.00	63.5 PK	74.0	-10.5	1.07 H	213	45.62	17.88
8	15540.00	48.4 AV	54.0	-5.6	1.07 H	213	30.52	17.88

ANTENNA POLARITY & TEST DISTANCE: VERTICAL AT 3 M

NO.	FREQ. (MHz)	EMISSION LEVEL (dBuV/m)	LIMIT (dBuV/m)	MARGIN (dB)	ANTENNA HEIGHT (m)	TABLE ANGLE (Degree)	RAW VALUE (dBuV)	CORRECTION FACTOR (dB/m)
1	5100.00	65.9 PK	74.0	-8.1	1.00 V	64	59.76	6.14
2	5100.00	53.3 AV	54.0	-0.7	1.00 V	64	47.16	6.14
3	*5180.00	116.7 PK			1.00 V	64	110.22	6.48
4	*5180.00	106.6 AV			1.00 V	64	100.12	6.48
5	#10360.00	57.1 PK	74.0	-16.9	1.00 V	146	44.62	12.48
6	#10360.00	44.3 AV	54.0	-9.7	1.00 V	146	31.82	12.48
7	15540.00	63.0 PK	74.0	-11.0	1.19 V	47	45.12	17.88
8	15540.00	48.6 AV	54.0	-5.4	1.19 V	47	30.72	17.88

REMARKS:

1. Emission Level(dBuV/m) = Raw Value(dBuV) + Correction Factor(dB/m)
2. Correction Factor(dB/m) = Antenna Factor(dB/m) + Cable Factor(dB) – Pre-Amplifier Factor(dB)
3. The other emission levels were very low against the limit.
4. Margin value = Emission Level – Limit value
5. " * ": Fundamental frequency.
6. " # ": The radiated frequency is out of the restricted band.



A D T

CHANNEL	TX Channel 40	DETECTOR FUNCTION	Peak (PK)
FREQUENCY RANGE	1GHz ~ 40GHz		Average (AV)

ANTENNA POLARITY & TEST DISTANCE: HORIZONTAL AT 3 M

NO.	FREQ. (MHz)	EMISSION LEVEL (dBuV/m)	LIMIT (dBuV/m)	MARGIN (dB)	ANTENNA HEIGHT (m)	TABLE ANGLE (Degree)	RAW VALUE (dBuV)	CORRECTION FACTOR (dB/m)
1	5120.00	64.3 PK	74.0	-9.7	1.00 H	278	58.07	6.23
2	5120.00	50.9 AV	54.0	-3.1	1.00 H	278	44.67	6.23
3	*5200.00	113.8 PK			1.00 H	278	107.23	6.57
4	*5200.00	104.4 AV			1.00 H	278	97.83	6.57
5	#10400.00	58.6 PK	74.0	-15.4	1.19 H	95	46.00	12.60
6	#10400.00	44.1 AV	54.0	-9.9	1.19 H	95	31.50	12.60
7	15600.00	63.6 PK	74.0	-10.4	1.10 H	216	45.78	17.82
8	15600.00	48.3 AV	54.0	-5.7	1.10 H	216	30.48	17.82

ANTENNA POLARITY & TEST DISTANCE: VERTICAL AT 3 M

NO.	FREQ. (MHz)	EMISSION LEVEL (dBuV/m)	LIMIT (dBuV/m)	MARGIN (dB)	ANTENNA HEIGHT (m)	TABLE ANGLE (Degree)	RAW VALUE (dBuV)	CORRECTION FACTOR (dB/m)
1	5120.00	66.4 PK	74.0	-7.6	1.05 V	61	60.17	6.23
2	5120.00	53.6 AV	54.0	-0.4	1.05 V	61	47.37	6.23
3	*5200.00	118.1 PK			1.01 V	67	111.53	6.57
4	*5200.00	107.3 AV			1.01 V	67	100.73	6.57
5	#10400.00	58.2 PK	74.0	-15.8	1.00 V	119	45.60	12.60
6	#10400.00	46.2 AV	54.0	-7.8	1.00 V	119	33.60	12.60
7	15600.00	62.7 PK	74.0	-11.3	1.22 V	29	44.88	17.82
8	15600.00	49.3 AV	54.0	-4.7	1.22 V	29	31.48	17.82

REMARKS:

1. Emission Level(dBuV/m) = Raw Value(dBuV) + Correction Factor(dB/m)
2. Correction Factor(dB/m) = Antenna Factor(dB/m) + Cable Factor(dB) – Pre-Amplifier Factor(dB)
3. The other emission levels were very low against the limit.
4. Margin value = Emission Level – Limit value
5. " * ": Fundamental frequency.
6. " # ": The radiated frequency is out of the restricted band.



A D T

CHANNEL	TX Channel 48	DETECTOR FUNCTION	Peak (PK)
FREQUENCY RANGE	1GHz ~ 40GHz		Average (AV)

ANTENNA POLARITY & TEST DISTANCE: HORIZONTAL AT 3 M

NO.	FREQ. (MHz)	EMISSION LEVEL (dBuV/m)	LIMIT (dBuV/m)	MARGIN (dB)	ANTENNA HEIGHT (m)	TABLE ANGLE (Degree)	RAW VALUE (dBuV)	CORRECTION FACTOR (dB/m)
1	5079.00	61.1 PK	74.0	-12.9	1.03 H	281	54.99	6.11
2	5079.00	49.3 AV	54.0	-4.7	1.03 H	281	43.19	6.11
3	*5240.00	115.3 PK			1.03 H	281	108.60	6.70
4	*5240.00	105.3 AV			1.03 H	281	98.60	6.70
5	5400.00	65.3 PK	74.0	-8.7	1.00 H	121	58.06	7.24
6	5400.00	52.4 AV	54.0	-1.6	1.00 H	121	45.16	7.24
7	#10480.00	57.9 PK	74.0	-16.1	1.17 H	103	45.33	12.57
8	#10480.00	43.5 AV	54.0	-10.5	1.17 H	103	30.93	12.57
9	15720.00	64.0 PK	74.0	-10.0	1.13 H	220	46.38	17.62
10	15720.00	48.4 AV	54.0	-5.6	1.13 H	220	30.78	17.62

ANTENNA POLARITY & TEST DISTANCE: VERTICAL AT 3 M

NO.	FREQ. (MHz)	EMISSION LEVEL (dBuV/m)	LIMIT (dBuV/m)	MARGIN (dB)	ANTENNA HEIGHT (m)	TABLE ANGLE (Degree)	RAW VALUE (dBuV)	CORRECTION FACTOR (dB/m)
1	5079.00	63.5 PK	74.0	-10.5	1.15 V	136	57.39	6.11
2	5079.00	51.5 AV	54.0	-2.5	1.15 V	136	45.39	6.11
3	*5240.00	120.1 PK			1.12 V	133	113.40	6.70
4	*5240.00	109.7 AV			1.12 V	133	103.00	6.70
5	5400.00	65.7 PK	74.0	-8.3	1.00 V	60	58.46	7.24
6	5400.00	53.5 AV	54.0	-0.5	1.00 V	60	46.26	7.24
7	#10480.00	56.8 PK	74.0	-17.2	1.00 V	145	44.23	12.57
8	#10480.00	43.7 AV	54.0	-10.3	1.00 V	145	31.13	12.57
9	15720.00	63.2 PK	74.0	-10.8	1.17 V	26	45.58	17.62
10	15720.00	48.7 AV	54.0	-5.3	1.17 V	26	31.08	17.62

REMARKS:

1. Emission Level(dBuV/m) = Raw Value(dBuV) + Correction Factor(dB/m)
2. Correction Factor(dB/m) = Antenna Factor(dB/m) + Cable Factor(dB) – Pre-Amplifier Factor(dB)
3. The other emission levels were very low against the limit.
4. Margin value = Emission Level – Limit value
5. " * ": Fundamental frequency.
6. " # ": The radiated frequency is out of the restricted band.



A D T

802.11ac (VHT20)

CHANNEL	TX Channel 36	DETECTOR FUNCTION	Peak (PK)
FREQUENCY RANGE	1GHz ~ 40GHz		Average (AV)

ANTENNA POLARITY & TEST DISTANCE: HORIZONTAL AT 3 M

NO.	FREQ. (MHz)	EMISSION LEVEL (dBuV/m)	LIMIT (dBuV/m)	MARGIN (dB)	ANTENNA HEIGHT (m)	TABLE ANGLE (Degree)	RAW VALUE (dBuV)	CORRECTION FACTOR (dB/m)
1	5100.00	63.4 PK	74.0	-10.6	1.00 H	274	57.26	6.14
2	5100.00	51.0 AV	54.0	-3.0	1.00 H	274	44.86	6.14
3	*5180.00	114.5 PK			1.03 H	280	108.02	6.48
4	*5180.00	105.7 AV			1.03 H	280	99.22	6.48
5	#10360.00	59.2 PK	74.0	-14.8	1.21 H	105	46.72	12.48
6	#10360.00	44.7 AV	54.0	-9.3	1.21 H	105	32.22	12.48
7	15540.00	64.7 PK	74.0	-9.3	1.12 H	207	46.82	17.88
8	15540.00	49.2 AV	54.0	-4.8	1.12 H	207	31.32	17.88

ANTENNA POLARITY & TEST DISTANCE: VERTICAL AT 3 M

NO.	FREQ. (MHz)	EMISSION LEVEL (dBuV/m)	LIMIT (dBuV/m)	MARGIN (dB)	ANTENNA HEIGHT (m)	TABLE ANGLE (Degree)	RAW VALUE (dBuV)	CORRECTION FACTOR (dB/m)
1	5100.00	65.7 PK	74.0	-8.3	1.04 V	67	59.56	6.14
2	5100.00	53.3 AV	54.0	-0.7	1.04 V	67	47.16	6.14
3	*5180.00	117.5 PK			1.00 V	65	111.02	6.48
4	*5180.00	107.3 AV			1.00 V	65	100.82	6.48
5	#10360.00	58.7 PK	74.0	-15.3	1.02 V	122	46.22	12.48
6	#10360.00	44.6 AV	54.0	-9.4	1.02 V	122	32.12	12.48
7	15540.00	64.5 PK	74.0	-9.5	1.22 V	30	46.62	17.88
8	15540.00	49.8 AV	54.0	-4.2	1.22 V	30	31.92	17.88

REMARKS:

1. Emission Level(dBuV/m) = Raw Value(dBuV) + Correction Factor(dB/m)
2. Correction Factor(dB/m) = Antenna Factor(dB/m) + Cable Factor(dB) – Pre-Amplifier Factor(dB)
3. The other emission levels were very low against the limit.
4. Margin value = Emission Level – Limit value
5. " * ": Fundamental frequency.
6. " # ": The radiated frequency is out of the restricted band.



A D T

CHANNEL	TX Channel 40	DETECTOR FUNCTION	Peak (PK)
FREQUENCY RANGE	1GHz ~ 40GHz		Average (AV)

ANTENNA POLARITY & TEST DISTANCE: HORIZONTAL AT 3 M

NO.	FREQ. (MHz)	EMISSION LEVEL (dBuV/m)	LIMIT (dBuV/m)	MARGIN (dB)	ANTENNA HEIGHT (m)	TABLE ANGLE (Degree)	RAW VALUE (dBuV)	CORRECTION FACTOR (dB/m)
1	5120.00	63.7 PK	74.0	-10.3	1.02 H	277	57.47	6.23
2	5120.00	51.3 AV	54.0	-2.7	1.02 H	277	45.07	6.23
3	*5200.00	114.0 PK			1.02 H	277	107.43	6.57
4	*5200.00	105.8 AV			1.02 H	277	99.23	6.57
5	#10400.00	59.4 PK	74.0	-14.6	1.16 H	88	46.80	12.60
6	#10400.00	44.8 AV	54.0	-9.2	1.16 H	88	32.20	12.60
7	15600.00	64.2 PK	74.0	-9.8	1.11 H	196	46.38	17.82
8	15600.00	49.3 AV	54.0	-4.7	1.11 H	196	31.48	17.82

ANTENNA POLARITY & TEST DISTANCE: VERTICAL AT 3 M

NO.	FREQ. (MHz)	EMISSION LEVEL (dBuV/m)	LIMIT (dBuV/m)	MARGIN (dB)	ANTENNA HEIGHT (m)	TABLE ANGLE (Degree)	RAW VALUE (dBuV)	CORRECTION FACTOR (dB/m)
1	5120.00	65.9 PK	74.0	-8.1	1.03 V	65	59.67	6.23
2	5120.00	53.2 AV	54.0	-0.8	1.03 V	65	46.97	6.23
3	*5200.00	118.3 PK			1.02 V	65	111.73	6.57
4	*5200.00	107.7 AV			1.02 V	65	101.13	6.57
5	#10400.00	58.9 PK	74.0	-15.1	1.02 V	117	46.30	12.60
6	#10400.00	44.6 AV	54.0	-9.4	1.02 V	117	32.00	12.60
7	15600.00	64.6 PK	74.0	-9.4	1.18 V	31	46.78	17.82
8	15600.00	50.1 AV	54.0	-3.9	1.18 V	31	32.28	17.82

REMARKS:

1. Emission Level(dBuV/m) = Raw Value(dBuV) + Correction Factor(dB/m)
2. Correction Factor(dB/m) = Antenna Factor(dB/m) + Cable Factor(dB) – Pre-Amplifier Factor(dB)
3. The other emission levels were very low against the limit.
4. Margin value = Emission Level – Limit value
5. " * ": Fundamental frequency.
6. " # ": The radiated frequency is out of the restricted band.



A D T

CHANNEL	TX Channel 48	DETECTOR FUNCTION	Peak (PK)
FREQUENCY RANGE	1GHz ~ 40GHz		Average (AV)

ANTENNA POLARITY & TEST DISTANCE: HORIZONTAL AT 3 M

NO.	FREQ. (MHz)	EMISSION LEVEL (dBuV/m)	LIMIT (dBuV/m)	MARGIN (dB)	ANTENNA HEIGHT (m)	TABLE ANGLE (Degree)	RAW VALUE (dBuV)	CORRECTION FACTOR (dB/m)
1	5140.00	60.3 PK	74.0	-13.7	1.00 H	45	53.98	6.32
2	5140.00	46.0 AV	54.0	-8.0	1.00 H	45	39.68	6.32
3	*5240.00	117.0 PK			1.02 H	301	110.30	6.70
4	*5240.00	105.3 AV			1.02 H	301	98.60	6.70
5	5400.00	64.3 PK	74.0	-9.7	1.02 H	301	57.06	7.24
6	5400.00	50.7 AV	54.0	-3.3	1.02 H	301	43.46	7.24
7	#10480.00	57.8 PK	74.0	-16.2	1.22 H	104	45.23	12.57
8	#10480.00	43.3 AV	54.0	-10.7	1.22 H	104	30.73	12.57
9	15720.00	63.3 PK	74.0	-10.7	1.08 H	222	45.68	17.62
10	15720.00	47.9 AV	54.0	-6.1	1.08 H	222	30.28	17.62

ANTENNA POLARITY & TEST DISTANCE: VERTICAL AT 3 M

NO.	FREQ. (MHz)	EMISSION LEVEL (dBuV/m)	LIMIT (dBuV/m)	MARGIN (dB)	ANTENNA HEIGHT (m)	TABLE ANGLE (Degree)	RAW VALUE (dBuV)	CORRECTION FACTOR (dB/m)
1	5140.00	62.4 PK	74.0	-11.6	1.00 V	111	56.08	6.32
2	5140.00	48.2 AV	54.0	-5.8	1.00 V	111	41.88	6.32
3	*5240.00	121.3 PK			1.02 V	64	114.60	6.70
4	*5240.00	109.5 AV			1.02 V	64	102.80	6.70
5	5400.00	66.1 PK	74.0	-7.9	1.01 V	63	58.86	7.24
6	5400.00	53.8 AV	54.0	-0.2	1.01 V	63	46.56	7.24
7	#10480.00	56.7 PK	74.0	-17.3	1.00 V	147	44.13	12.57
8	#10480.00	43.5 AV	54.0	-10.5	1.00 V	147	30.93	12.57
9	15720.00	61.8 PK	74.0	-12.2	1.25 V	31	44.18	17.62
10	15720.00	47.5 AV	54.0	-6.5	1.25 V	31	29.88	17.62

REMARKS:

1. Emission Level(dBuV/m) = Raw Value(dBuV) + Correction Factor(dB/m)
2. Correction Factor(dB/m) = Antenna Factor(dB/m) + Cable Factor(dB) – Pre-Amplifier Factor(dB)
3. The other emission levels were very low against the limit.
4. Margin value = Emission Level – Limit value
5. " * ": Fundamental frequency.
6. " # ": The radiated frequency is out of the restricted band.



A D T

802.11ac (VHT40)

CHANNEL	TX Channel 38	DETECTOR FUNCTION	Peak (PK)
FREQUENCY RANGE	1GHz ~ 40GHz		Average (AV)

ANTENNA POLARITY & TEST DISTANCE: HORIZONTAL AT 3 M

NO.	FREQ. (MHz)	EMISSION LEVEL (dBuV/m)	LIMIT (dBuV/m)	MARGIN (dB)	ANTENNA HEIGHT (m)	TABLE ANGLE (Degree)	RAW VALUE (dBuV)	CORRECTION FACTOR (dB/m)
1	5150.00	68.4 PK	74.0	-5.6	1.02 H	279	62.04	6.36
2	5150.00	51.3 AV	54.0	-2.7	1.02 H	279	44.94	6.36
3	*5190.00	109.6 PK			1.02 H	279	103.07	6.53
4	*5190.00	98.4 AV			1.02 H	279	91.87	6.53
5	#10380.00	57.9 PK	74.0	-16.1	1.18 H	104	45.36	12.54
6	#10380.00	43.2 AV	54.0	-10.8	1.18 H	104	30.66	12.54
7	15570.00	63.5 PK	74.0	-10.5	1.07 H	221	45.65	17.85
8	15570.00	47.9 AV	54.0	-6.1	1.07 H	221	30.05	17.85

ANTENNA POLARITY & TEST DISTANCE: VERTICAL AT 3 M

NO.	FREQ. (MHz)	EMISSION LEVEL (dBuV/m)	LIMIT (dBuV/m)	MARGIN (dB)	ANTENNA HEIGHT (m)	TABLE ANGLE (Degree)	RAW VALUE (dBuV)	CORRECTION FACTOR (dB/m)
1	5150.00	70.1 PK	74.0	-3.9	1.01 V	62	63.74	6.36
2	5150.00	53.5 AV	54.0	-0.5	1.01 V	62	47.14	6.36
3	*5190.00	112.7 PK			1.01 V	62	106.17	6.53
4	*5190.00	102.6 AV			1.01 V	62	96.07	6.53
5	#10380.00	56.7 PK	74.0	-17.3	1.00 V	121	44.16	12.54
6	#10380.00	43.7 AV	54.0	-10.3	1.00 V	121	31.16	12.54
7	15570.00	61.5 PK	74.0	-12.5	1.19 V	28	43.65	17.85
8	15570.00	47.1 AV	54.0	-6.9	1.19 V	28	29.25	17.85

REMARKS:

1. Emission Level(dBuV/m) = Raw Value(dBuV) + Correction Factor(dB/m)
2. Correction Factor(dB/m) = Antenna Factor(dB/m) + Cable Factor(dB) – Pre-Amplifier Factor(dB)
3. The other emission levels were very low against the limit.
4. Margin value = Emission Level – Limit value
5. " * ": Fundamental frequency.
6. " # ": The radiated frequency is out of the restricted band.



A D T

CHANNEL	TX Channel 46	DETECTOR FUNCTION	Peak (PK)
FREQUENCY RANGE	1GHz ~ 40GHz		Average (AV)

ANTENNA POLARITY & TEST DISTANCE: HORIZONTAL AT 3 M

NO.	FREQ. (MHz)	EMISSION LEVEL (dBuV/m)	LIMIT (dBuV/m)	MARGIN (dB)	ANTENNA HEIGHT (m)	TABLE ANGLE (Degree)	RAW VALUE (dBuV)	CORRECTION FACTOR (dB/m)
1	5140.00	65.2 PK	74.0	-8.8	1.01 H	277	58.88	6.32
2	5140.00	53.4 AV	54.0	-0.6	1.01 H	277	47.08	6.32
3	*5230.00	113.1 PK			1.01 H	277	106.44	6.66
4	*5230.00	104.0 AV			1.01 H	277	97.34	6.66
5	5390.00	64.3 PK	74.0	-9.7	1.01 H	277	57.09	7.21
6	5390.00	52.0 AV	54.0	-2.0	1.01 H	277	44.79	7.21
7	#10460.00	59.8 PK	74.0	-14.2	1.17 H	101	47.22	12.58
8	#10460.00	45.3 AV	54.0	-8.7	1.17 H	101	32.72	12.58
9	15690.00	64.7 PK	74.0	-9.3	1.10 H	220	47.10	17.60
10	15690.00	49.3 AV	54.0	-4.7	1.10 H	220	31.70	17.60

ANTENNA POLARITY & TEST DISTANCE: VERTICAL AT 3 M

NO.	FREQ. (MHz)	EMISSION LEVEL (dBuV/m)	LIMIT (dBuV/m)	MARGIN (dB)	ANTENNA HEIGHT (m)	TABLE ANGLE (Degree)	RAW VALUE (dBuV)	CORRECTION FACTOR (dB/m)
1	5140.00	65.5 PK	74.0	-8.5	1.01 V	59	59.18	6.32
2	5140.00	53.6 AV	54.0	-0.4	1.01 V	59	47.28	6.32
3	*5230.00	118.2 PK			1.01 V	59	111.54	6.66
4	*5230.00	112.7 AV			1.01 V	59	106.04	6.66
5	5390.00	65.5 PK	74.0	-8.5	1.01 V	59	58.29	7.21
6	5390.00	53.0 AV	54.0	-1.0	1.01 V	59	45.79	7.21
7	#10460.00	57.8 PK	74.0	-16.2	1.01 V	148	45.22	12.58
8	#10460.00	45.0 AV	54.0	-9.0	1.01 V	148	32.42	12.58
9	15690.00	64.2 PK	74.0	-9.8	1.25 V	34	46.60	17.60
10	15690.00	49.9 AV	54.0	-4.1	1.25 V	34	32.30	17.60

REMARKS:

1. Emission Level(dBuV/m) = Raw Value(dBuV) + Correction Factor(dB/m)
2. Correction Factor(dB/m) = Antenna Factor(dB/m) + Cable Factor(dB) – Pre-Amplifier Factor(dB)
3. The other emission levels were very low against the limit.
4. Margin value = Emission Level – Limit value
5. " * ": Fundamental frequency.
6. " # ": The radiated frequency is out of the restricted band.



A D T

802.11ac (VHT80)

CHANNEL	TX Channel 42	DETECTOR FUNCTION	Peak (PK)
FREQUENCY RANGE	1GHz ~ 40GHz		Average (AV)

ANTENNA POLARITY & TEST DISTANCE: HORIZONTAL AT 3 M

NO.	FREQ. (MHz)	EMISSION LEVEL (dBuV/m)	LIMIT (dBuV/m)	MARGIN (dB)	ANTENNA HEIGHT (m)	TABLE ANGLE (Degree)	RAW VALUE (dBuV)	CORRECTION FACTOR (dB/m)
1	5140.00	65.4 PK	74.0	-8.6	1.01 H	276	59.08	6.32
2	5140.00	50.8 AV	54.0	-3.2	1.01 H	276	44.48	6.32
3	*5210.00	107.2 PK			1.01 H	276	100.61	6.59
4	*5210.00	96.3 AV			1.01 H	276	89.71	6.59
5	#5788.00	66.3 PK	68.2	-1.9	1.00 H	60	58.25	8.05
6	#10420.00	57.0 PK	74.0	-17.0	1.25 H	94	44.41	12.59
7	#10420.00	42.8 AV	54.0	-11.2	1.25 H	94	30.21	12.59
8	15630.00	62.9 PK	74.0	-11.1	1.12 H	221	45.15	17.75
9	15630.00	47.6 AV	54.0	-6.4	1.12 H	221	29.85	17.75

ANTENNA POLARITY & TEST DISTANCE: VERTICAL AT 3 M

NO.	FREQ. (MHz)	EMISSION LEVEL (dBuV/m)	LIMIT (dBuV/m)	MARGIN (dB)	ANTENNA HEIGHT (m)	TABLE ANGLE (Degree)	RAW VALUE (dBuV)	CORRECTION FACTOR (dB/m)
1	5140.00	67.1 PK	74.0	-6.9	1.07 V	59	60.78	6.32
2	5140.00	53.6 AV	54.0	-0.4	1.07 V	59	47.28	6.32
3	*5210.00	111.2 PK			1.07 V	59	104.61	6.59
4	*5210.00	100.0 AV			1.07 V	59	93.41	6.59
5	#5788.00	68.1 PK	68.2	-0.1	1.05 V	114	60.05	8.05
6	#10420.00	57.3 PK	74.0	-16.7	1.00 V	127	44.71	12.59
7	#10420.00	44.2 AV	54.0	-9.8	1.00 V	127	31.61	12.59
8	15630.00	62.8 PK	74.0	-11.2	1.23 V	40	45.05	17.75
9	15630.00	48.2 AV	54.0	-5.8	1.23 V	40	30.45	17.75

REMARKS:

1. Emission Level(dBuV/m) = Raw Value(dBuV) + Correction Factor(dB/m)
2. Correction Factor(dB/m) = Antenna Factor(dB/m) + Cable Factor(dB) – Pre-Amplifier Factor(dB)
3. The other emission levels were very low against the limit.
4. Margin value = Emission Level – Limit value
5. " * ": Fundamental frequency.
6. " # ": The radiated frequency is out of the restricted band.

4.3 TRANSMIT POWER MEASUREMENT

4.3.1 LIMITS OF TRANSMIT POWER MEASUREMENT

Operation Band	EUT Category		LIMIT
U-NII-1		Outdoor Access Point	1 Watt (30 dBm) (Max. e.i.r.p 125mW(21 dBm) at any elevation angle above 30 degrees as measured from the horizon)
		Fixed point-to-point Access Point	1 Watt (30 dBm)
	√	Indoor Access Point	1 Watt (30 dBm)
		Mobile and Portable client device	250mW (24 dBm)
U-NII-2A	---		250mW (24 dBm) or 11 dBm+10 log B*
U-NII-2C	---		250mW (24 dBm) or 11 dBm+10 log B*
U-NII-3	---		1 Watt (30 dBm)

Note: Where B is the 26dB emission bandwidth in MHz.

Per KDB 662911 D01 Multiple Transmitter Output Method of conducted output power measurement on IEEE 802.11 devices,

Array Gain = 0 dB (i.e., no array gain) for NANT \leq 4;

Array Gain = 0 dB (i.e., no array gain) for channel widths \geq 40 MHz for any NANT;

Array Gain = 5 log(NANT/NSS) dB or 3 dB, whichever is less for 20-MHz channel widths with NANT \geq 5.

For power measurements on all other devices: Array Gain = 10 log(NANT/NSS) dB.



A D T

4.3.2 TEST INSTRUMENTS

FOR POWER OUTPUT MEASUREMENT

DESCRIPTION & MANUFACTURER	MODEL NO.	SERIAL NO.	CALIBRATED DATE	CALIBRATED UNTIL
Power meter Anritsu	ML2495A	1014008	Apr. 30, 2014	Apr. 29, 2015
Power sensor Anritsu	MA2411B	0917122	Apr. 30, 2014	Apr. 29, 2015

Note:

1. The calibration interval of the above test instruments is 12 months and the calibrations are traceable to NML/ROC and NIST/USA.
2. Tested date : July 29, 2014

FOR 26dB OCCUPIED BANDWIDTH

DESCRIPTION & MANUFACTURER	MODEL NO.	SERIAL NO.	CALIBRATED DATE	CALIBRATED UNTIL
SPECTRUM ANALYZER R&S	FSV 40	100964	July 05, 2014	July 04, 2015

Note:

1. The calibration interval of the above test instruments is 12 months and the calibrations are traceable to NML/ROC and NIST/USA.
2. Tested date : July 29, 2014

4.3.3 TEST PROCEDURE

FOR POWER OUTPUT MEASUREMENT

Method PM is used to perform output power measurement, trigger and gating function of wide band power meter is enabled to measure max output power of TX on burst. Duty factor is not added to measured value.

FOR 26dB OCCUPIED BANDWIDTH

1. Set RBW = approximately 1% of the emission bandwidth.
2. Set the VBW > RBW.
3. Detector = Peak.
4. Trace mode = max hold.
5. Measure the maximum width of the emission that is 26 dB down from the peak of the emission. Compare this with the RBW setting of the analyzer. Readjust RBW and repeat measurement as needed until the RBW/EBW ratio is approximately 1%.

4.3.4 DEVIATION FROM TEST STANDARD

No deviation

4.3.5 TEST SETUP

FOR POWER OUTPUT MEASUREMENT

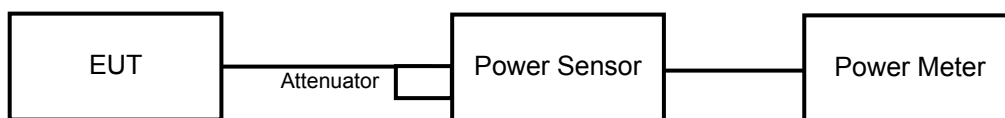

FOR 26dB OCCUPIED BANDWIDTH

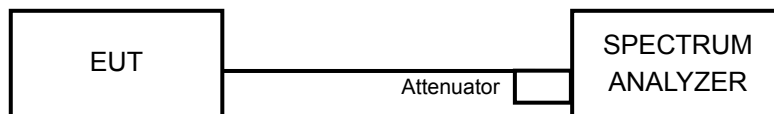

4.3.6 EUT OPERATING CONDITIONS

The software provided by client to enable the EUT under transmission condition continuously at specific channel frequencies individually.



A D T

802.11ac (VHT20)

CHAN.	CHAN. FREQ. (MHz)	AVERAGE POWER (dBm)			TOTAL POWER (mW)	TOTAL POWER (dBm)	POWER LIMIT (dBm)	PASS / FAIL
		CHAIN 0	CHAIN 1	CHAIN 2				
36	5180	15.95	16.28	16.36	125.068	20.97	29.23	PASS
40	5200	15.96	16.38	16.37	126.248	21.01	29.23	PASS
48	5240	19.40	19.87	19.32	269.654	24.31	29.23	PASS

Note: The directional gain is 6.77dBi > 6dBi, therefore the limit needs to reduce, so the power limit shall be reduced to "Determined Conducted Limit-(6.77-6)".

26dB OCCUPIED BANDWIDTH:

CHANNEL	CHANNEL FREQUENCY (MHz)	26dBc BANDWIDTH (MHz)		
		CHAIN 0	CHAIN 1	CHAIN 2
36	5180	20.92	20.65	20.82
40	5200	20.77	20.76	20.55
48	5240	20.77	20.56	20.77

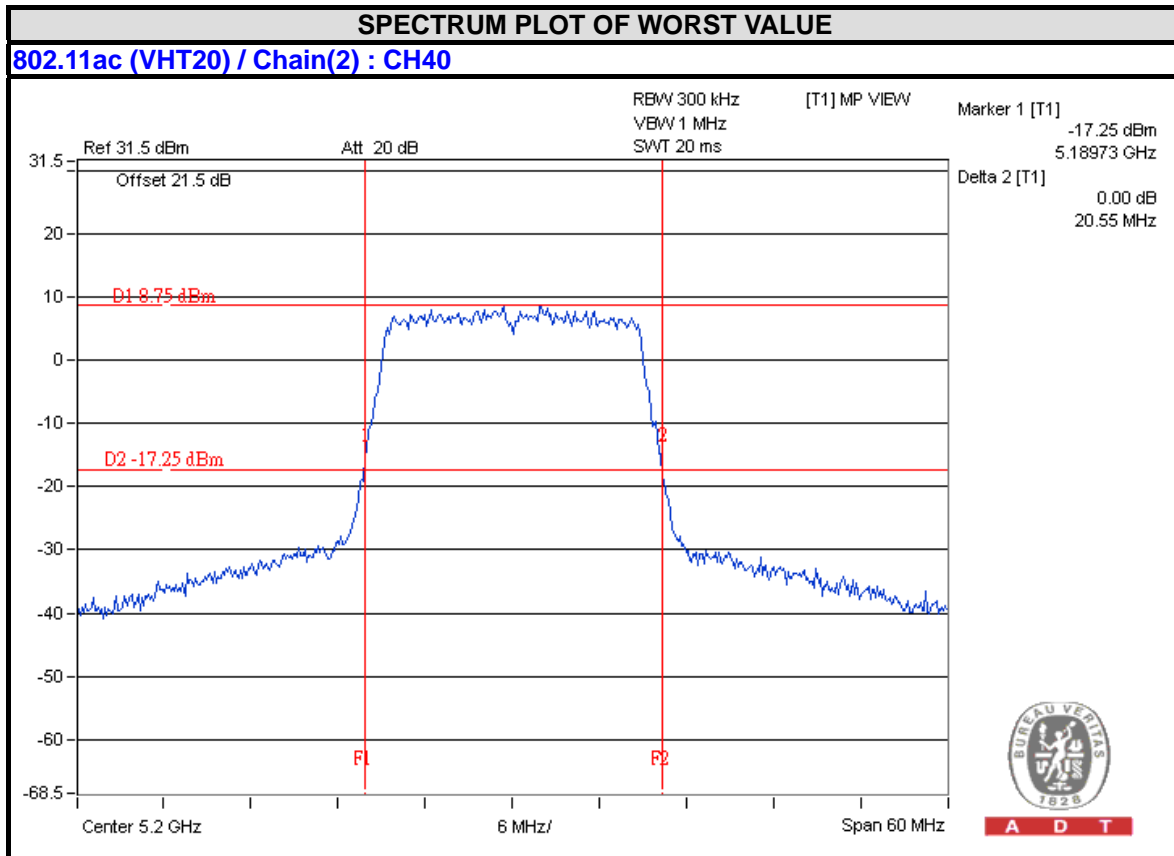



A D T

802.11ac (VHT40)

CHAN.	CHAN. FREQ. (MHz)	AVERAGE POWER (dBm)			TOTAL POWER (mW)	TOTAL POWER (dBm)	POWER LIMIT (dBm)	PASS / FAIL
		CHAIN 0	CHAIN 1	CHAIN 2				
38	5190	14.62	14.90	15.10	92.235	19.65	29.23	PASS
46	5230	18.63	19.34	18.95	237.371	23.75	29.23	PASS

Note: The directional gain is 6.77dBi > 6dBi, therefore the limit needs to reduce, so the power limit shall be reduced to "Determined Conducted Limit-(6.77-6)".

26dB OCCUPIED BANDWIDTH:

CHANNEL	CHANNEL FREQUENCY (MHz)	26dBc BANDWIDTH (MHz)		
		CHAIN 0	CHAIN 1	CHAIN 2
38	5190	41.47	41.21	40.99
46	5230	41.64	41.20	41.15

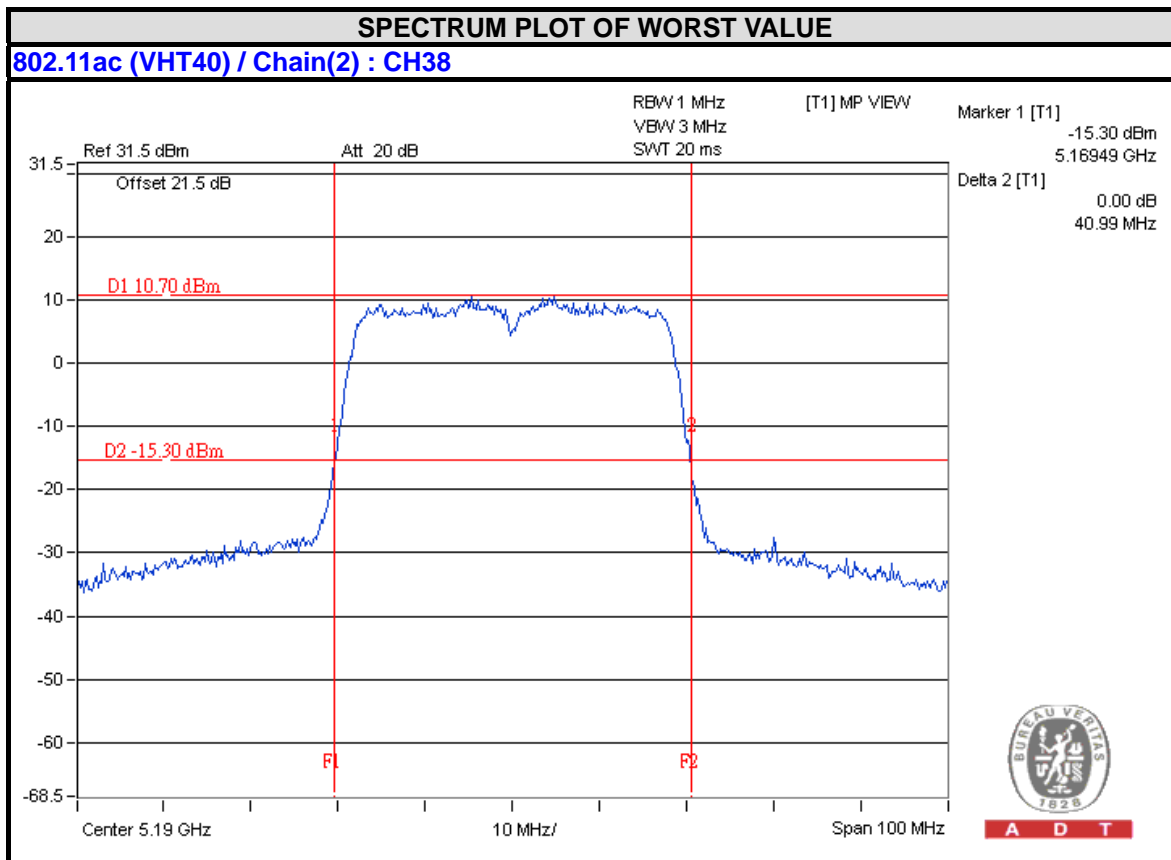



A D T

802.11ac (VHT80)

CHAN.	CHAN. FREQ. (MHz)	AVERAGE POWER (dBm)			TOTAL POWER (mW)	TOTAL POWER (dBm)	POWER LIMIT (dBm)	PASS / FAIL
		CHAIN 0	CHAIN 1	CHAIN 2				
42	5210	14.15	14.62	14.98	86.452	19.37	29.23	PASS

Note: The directional gain is 6.77dBi > 6dBi, therefore the limit needs to reduce, so the power limit shall be reduced to "Determined Conducted Limit-(6.77-6)".

26dB OCCUPIED BANDWIDTH:

CHANNEL	CHANNEL FREQUENCY (MHz)	26dBc BANDWIDTH (MHz)		
		CHAIN 0	CHAIN 1	CHAIN 2
42	5210	82.98	82.68	83.13

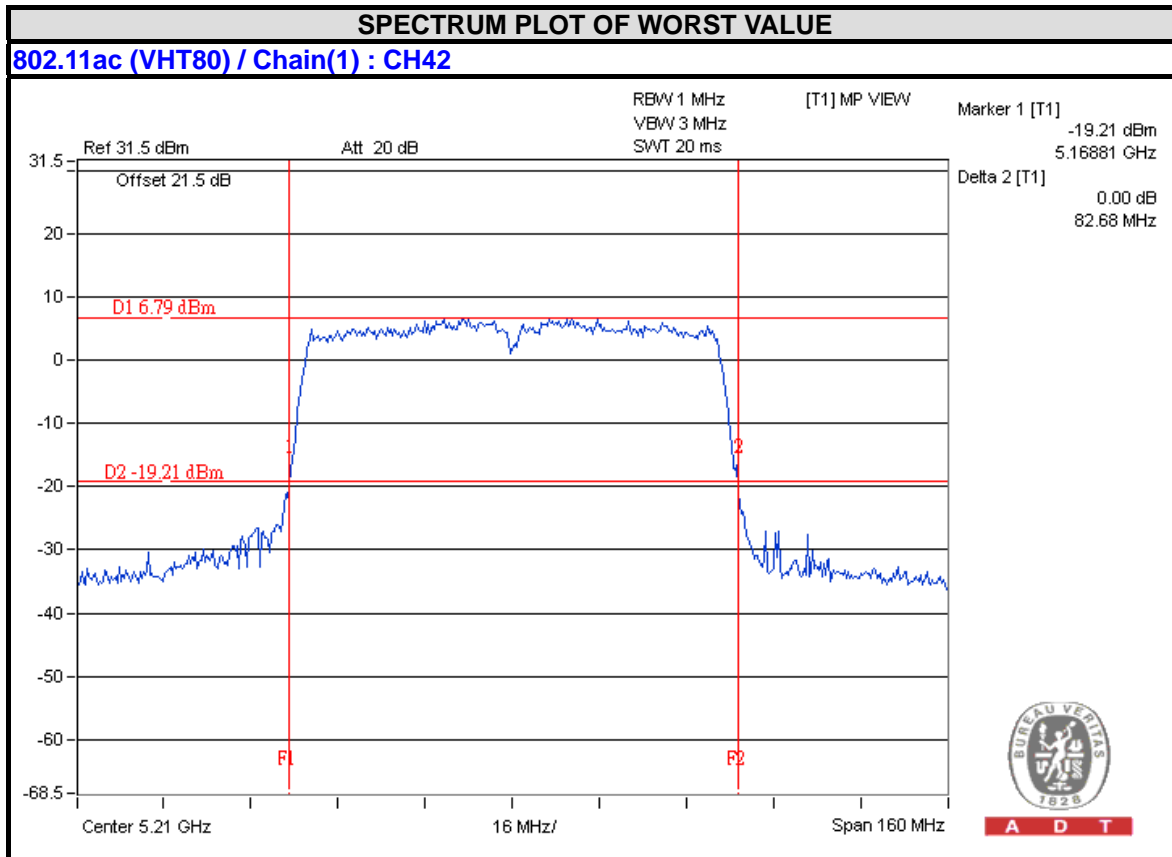



A D T

4.4 PEAK POWER SPECTRAL DENSITY MEASUREMENT

4.4.1 LIMITS OF PEAK POWER SPECTRAL DENSITY MEASUREMENT

Operation Band	EUT Category		LIMIT
U-NII-1		Outdoor Access Point	17dBm/ MHz
		Fixed point-to-point Access Point	
	√	Indoor Access Point	
		Mobile and Portable client device	11dBm/ MHz
U-NII-2A	---		11dBm/ MHz
U-NII-2C	---		11dBm/ MHz
U-NII-3	---		30dBm/ 500kHz

4.4.2 TEST INSTRUMENTS

DESCRIPTION & MANUFACTURER	MODEL NO.	SERIAL NO.	CALIBRATED DATE	CALIBRATED UNTIL
SPECTRUM ANALYZER R&S	FSV 40	100964	July 05, 2014	July 04, 2015

Note:

1. The calibration interval of the above test instruments is 12 months and the calibrations are traceable to NML/ROC and NIST/USA.
2. Tested date : July 29, 2014

4.4.3 TEST PROCEDURES

1. Set span to encompass the entire emission bandwidth (EBW) of the signal.
2. Set RBW = 1 MHz, Set VBW \geq 3 MHz, Detector = RMS
3. Sweep time = auto, trigger set to “free run”.
4. Trace average at least 100 traces in power averaging mode.
5. Record the max value and for duty cycle of test signal is $<$ 98% add $10 \log (1/\text{duty cycle})$

4.4.4 DEVIATION FROM TEST STANDARD

No deviation

4.4.5 TEST SETUP

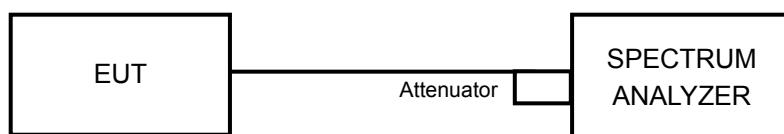

4.4.6 EUT OPERATING CONDITIONS

Same as 4.3.6



4.4.7 TEST RESULTS

802.11a

CHANNEL	CHANNEL FREQUENCY (MHz)	PSD (dBm)			TOTAL POWER DENSITY (dBm)	MAX. LIMIT (dBm)	PASS/FAIL
		CHAIN 0	CHAIN 1	CHAIN 2			
36	5180	2.10	2.40	2.22	7.01	16.23	PASS
40	5200	1.63	2.28	1.94	6.73	16.23	PASS
48	5240	5.63	6.24	5.88	10.70	16.23	PASS

- NOTE:** 1. Method a) of power density measurement of KDB 662911 is using for calculating total power density. Total power density is summing entire spectra across corresponding frequency bins on the various outputs by computer.
2. Directional gain = $2\text{dBi} + 10\log(3) = 6.77\text{dBi} > 6\text{dBi}$, so the power density limit shall be reduced to $17 - (6.77 - 6) = 16.23\text{dBm}$.

802.11ac (VHT20)

CHANNEL	CHANNEL FREQUENCY (MHz)	PSD (dBm)			TOTAL POWER DENSITY (dBm)	MAX. LIMIT (dBm)	PASS/FAIL
		CHAIN 0	CHAIN 1	CHAIN 2			
36	5180	2.77	2.87	2.90	7.62	16.23	PASS
40	5200	2.90	3.05	2.98	7.75	16.23	PASS
48	5240	5.98	6.79	6.07	11.07	16.23	PASS

- NOTE:** 1. Method a) of power density measurement of KDB 662911 is using for calculating total power density. Total power density is summing entire spectra across corresponding frequency bins on the various outputs by computer.
2. Directional gain = $2\text{dBi} + 10\log(3) = 6.77\text{dBi} > 6\text{dBi}$, so the power density limit shall be reduced to $17 - (6.77 - 6) = 16.23\text{dBm}$.



802.11ac (VHT40)

CHANNEL	CHANNEL FREQUENCY (MHz)	PSD W/O DUTY FACTOR (dBm)			DUTY FACTOR (dB)	TOTAL PSD WITH DUTY FACTOR (dBm)	MAX. LIMIT (dBm)	PASS / FAIL
		CHAIN 0	CHAIN 1	CHAIN 2				
38	5190	-1.86	-1.65	-1.38	0.11	3.26	16.23	PASS
46	5230	2.55	2.82	3.07	0.11	7.70	16.23	PASS

- NOTE:** 1. Method a) of power density measurement of KDB 662911 is using for calculating total power density. Total power density is summing entire spectra across corresponding frequency bins on the various outputs by computer.
2. Directional gain = $2\text{dBi} + 10\log(3) = 6.77\text{dBi} > 6\text{dBi}$, so the power density limit shall be reduced to $17-(6.77-6) = 16.23\text{dBm}$.
3. Refer to section 3.4 for duty cycle spectrum plot.

802.11ac (VHT80)

CHANNEL	CHANNEL FREQUENCY (MHz)	PSD W/O DUTY FACTOR (dBm)			DUTY FACTOR (dB)	TOTAL PSD WITH DUTY FACTOR (dBm)	MAX. LIMIT (dBm)	PASS / FAIL
		CHAIN 0	CHAIN 1	CHAIN 2				
42	5210	-5.63	-5.17	-4.74	0.19	-0.21	16.23	PASS

- NOTE:** 1. Method a) of power density measurement of KDB 662911 is using for calculating total power density. Total power density is summing entire spectra across corresponding frequency bins on the various outputs by computer.
2. Directional gain = $2\text{dBi} + 10\log(3) = 6.77\text{dBi} > 6\text{dBi}$, so the power density limit shall be reduced to $17-(6.77-6) = 16.23\text{dBm}$.
3. Refer to section 3.4 for duty cycle spectrum plot.



A D T

SPECTRUM PLOT OF WORST VALUE

802.11a / Chain(1) : CH48

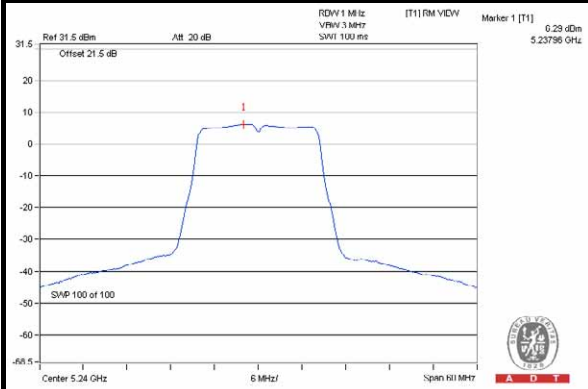

802.11ac (VHT20) / Chain(1) : CH48

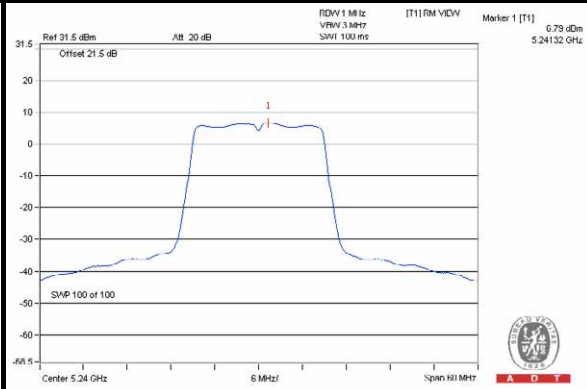

802.11ac (VHT40) / Chain(2) : CH46

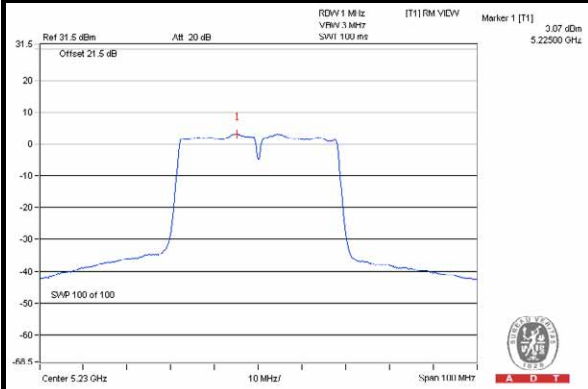

802.11ac (VHT80) / Chain(2) : CH42

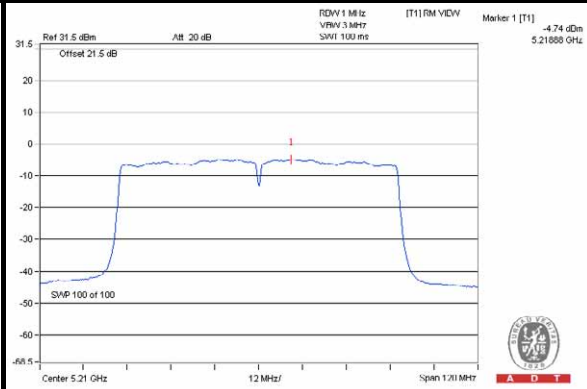



A D T

4.5 FREQUENCY STABILITY

4.5.1 LIMITS OF FREQUENCY STABILITY MEASUREMENT

The frequency of the carrier signal shall be maintained within band of operation

4.5.2 TEST INSTRUMENTS

DESCRIPTION & MANUFACTURER	MODEL NO.	SERIAL NO.	CALIBRATED DATE	CALIBRATED UNTIL
SPECTRUM ANALYZER R&S	FSV 40	100964	July 05, 2014	July 04, 2015
Temperature Humidity Chamber GIANTFORCE &	GTH-150-40-SP -AR	MAA0812-008	Jan. 13, 2014	Jan. 12, 2015

Note:

1. The calibration interval of the above test instruments is 12 months and the calibrations are traceable to NML/ROC and NIST/USA.
2. Tested date : July 29, 2014

4.5.3 TEST PROCEDURE

1. The EUT was placed inside the environmental test chamber and powered by nominal AC voltage.
2. Turn the EUT on and couple its output to a spectrum analyzer.
3. Turn the EUT off and set the chamber to the highest temperature specified.
4. Allow sufficient time (approximately 30 min) for the temperature of the chamber to stabilize, turn the EUT on and measure the operating frequency after 2, 5, and 10 minutes.
5. Repeat step 2 and 3 with the temperature chamber set to the lowest temperature.
6. The test chamber was allowed to stabilize at +20 degree C for a minimum of 30 minutes. The supply voltage was then adjusted on the EUT from 85% to 115% and the frequency record.

4.5.4 DEVIATION FROM TEST STANDARD

No deviation

4.5.5 TEST SETUP

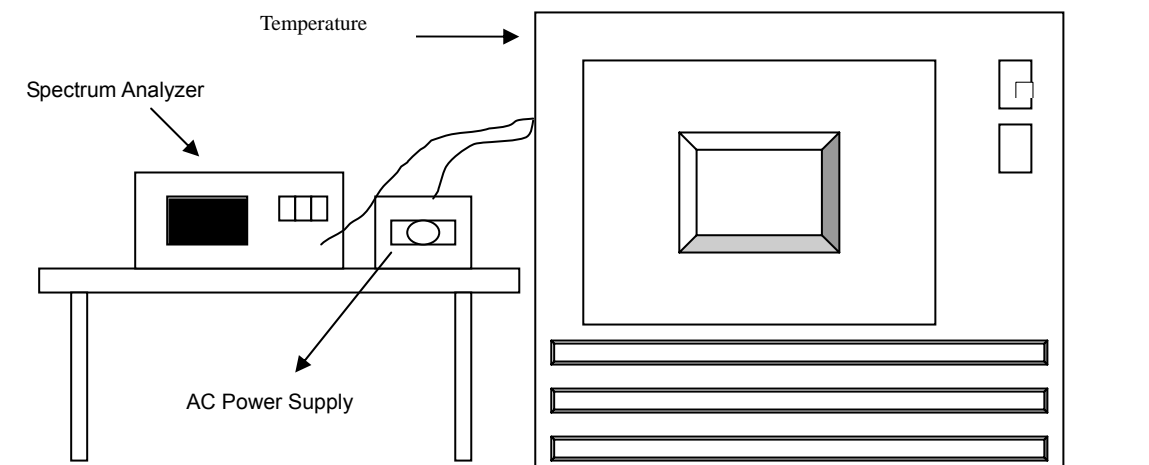

4.5.6 EUT OPERATING CONDITION

Set the EUT transmit at un-modulation mode to test frequency stability.



A D T

4.5.7 TEST RESULTS

FREQUENCY STABILITY VERSUS TEMP.									
OPERATING FREQUENCY: 5240MHz									
TEMP. ()	POWER SUPPLY (Vac)	0 MINUTE		2 MINUTE		5 MINUTE		10 MINUTE	
		Measured Frequency	Frequency Drift	Measured Frequency	Frequency Drift	Measured Frequency	Frequency Drift	Measured Frequency	Frequency Drift
		(MHz)	%	(MHz)	%	(MHz)	%	(MHz)	%
50	120	5239.9866	-0.00026	5239.9903	-0.00019	5239.9902	-0.00019	5239.9872	-0.00024
40	120	5240.0195	0.00037	5240.0207	0.00040	5240.0199	0.00038	5240.0186	0.00035
30	120	5239.9869	-0.00025	5239.9865	-0.00026	5239.985	-0.00029	5239.9875	-0.00024
20	120	5239.9811	-0.00036	5239.9809	-0.00036	5239.9799	-0.00038	5239.9794	-0.00039
10	120	5239.9818	-0.00035	5239.9821	-0.00034	5239.9846	-0.00029	5239.981	-0.00036
0	120	5240.0196	0.00037	5240.0195	0.00037	5240.0195	0.00037	5240.0202	0.00039
-10	120	5239.9843	-0.00030	5239.9812	-0.00036	5239.9851	-0.00028	5239.9857	-0.00027
-20	120	5240.0255	0.00049	5240.0252	0.00048	5240.0229	0.00044	5240.0264	0.00050
-30	120	5239.9973	-0.00005	5239.9967	-0.00006	5239.9967	-0.00006	5239.9958	-0.00008

FREQUENCY STABILITY VERSUS VOLTAGE									
OPERATING FREQUENCY: 5240MHz									
TEMP. ()	POWER SUPPLY (Vac)	0 MINUTE		2 MINUTE		5 MINUTE		10 MINUTE	
		Measured Frequency	Frequency Drift	Measured Frequency	Frequency Drift	Measured Frequency	Frequency Drift	Measured Frequency	Frequency Drift
		(MHz)	%	(MHz)	%	(MHz)	%	(MHz)	%
20	138	5239.9801	-0.00038	5239.9802	-0.00038	5239.9791	-0.00040	5239.98	-0.00038
	120	5239.9811	-0.00036	5239.9809	-0.00036	5239.9799	-0.00038	5239.9794	-0.00039
	102	5239.9821	-0.00034	5239.9807	-0.00037	5239.9805	-0.00037	5239.979	-0.00040



A D T

5. PHOTOGRAPHS OF THE TEST CONFIGURATION

Please refer to the attached file (Test Setup Photo).



A D T

6. INFORMATION ON THE TESTING LABORATORIES

We, Bureau Veritas Consumer Products Services (H.K.) Ltd., Taoyuan Branch, were founded in 1988 to provide our best service in EMC, Radio, Telecom and Safety consultation. Our laboratories are accredited and approved according to ISO/IEC 17025.

If you have any comments, please feel free to contact us at the following:

Linko EMC/RF Lab:

Tel: 886-2-26052180

Fax: 886-2-26052943

Hsin Chu EMC/RF/Telecom Lab:

Tel: 886-3-5935343

Fax: 886-3-5935342

Hwa Ya EMC/RF/Safety Lab:

Tel: 886-3-3183232

Fax: 886-3-3270892

Email: service.adt@tw.bureauveritas.com

Web Site: www.bureauveritas-adt.com

The address and road map of all our labs can be found in our web site also.



A D T

7. APPENDIX A - MODIFICATIONS RECORDERS FOR ENGINEERING CHANGES TO THE EUT BY THE LAB

No modifications were made to the EUT by the lab during the test.

--- END ---