



# SPORTON International Inc.

No. 52, Hwa Ya 1st Rd., Kwei-Shan Hsiang, TaoYuan Hsien, Taiwan, R.O.C.  
Ph: 886-3-327-3456 / FAX: 886-3-327-0973 / www.sporton.com.tw

## FCC RADIO TEST REPORT

Applicant's company	NETGEAR, Inc.
Applicant Address	350 East Plumeria Drive, San Jose, California 95134, USA
FCC ID	PY312400219
Manufacturer's company	Ambit Microsystems (Shanghai) Ltd.
Manufacturer Address	No. 1925, Nanle Road, Songjiang Export Processing Zone, Shanghai, China

Product Name	R6250 Smart WiFi Router
Brand Name	NETGEAR
Model Name	R6250
Test Rule Part(s)	47 CFR FCC Part 15 Subpart C § 15.247
Test Freq. Range	2400 ~ 2483.5MHz / 5725 ~ 5850MHz
Received Date	Jan. 07, 2013
Final Test Date	Feb. 19, 2013
Submission Type	Original Equipment

### Statement

Test result included is only for the IEEE 802.11n, IEEE 802.11b/g part and IEEE 802.11a/ac (5725 ~ 5850MHz) of the product.

The test result in this report refers exclusively to the presented test model / sample.

Without written approval of SPORTON International Inc., the test report shall not be reproduced except in full.

The measurements and test results shown in this test report were made in accordance with the procedures and found in compliance with the limit given in ANSI C63.10-2009,

47 CFR FCC Part 15 Subpart C, KDB 558074 D01 v02 and KDB 662911 D01 v01r02.

The test equipment used to perform the test is calibrated and traceable to NML/ROC.



## Table of Contents

<b>1. CERTIFICATE OF COMPLIANCE</b> .....	<b>1</b>
<b>2. SUMMARY OF THE TEST RESULT</b> .....	<b>2</b>
<b>3. GENERAL INFORMATION</b> .....	<b>3</b>
3.1. Product Details .....	3
3.2. Accessories .....	6
3.3. Table for Filed Antenna .....	7
3.4. Table for Carrier Frequencies .....	8
3.5. Table for Test Modes .....	9
3.6. Table for Testing Locations.....	11
3.7. Table for Supporting Units .....	11
3.8. Table for Parameters of Test Software Setting .....	12
3.9. Test Configurations.....	14
<b>4. TEST RESULT</b> .....	<b>17</b>
4.1. AC Power Line Conducted Emissions Measurement .....	17
4.2. Maximum Conducted Output Power Measurement.....	23
4.3. Power Spectral Density Measurement.....	27
4.4. 6dB Spectrum Bandwidth Measurement .....	37
4.5. Radiated Emissions Measurement.....	45
4.6. Emissions Measurement.....	77
4.7. Antenna Requirements .....	98
<b>5. LIST OF MEASURING EQUIPMENTS</b> .....	<b>99</b>
<b>6. TEST LOCATION</b> .....	<b>101</b>
<b>APPENDIX A. TEST PHOTOS</b> .....	<b>A1 ~ A5</b>
<b>APPENDIX B. MAXIMUM PERMISSIBLE EXPOSURE</b> .....	<b>B1 ~ B3</b>
<b>APPENDIX C. CO-LOCATION REPORT</b> .....	<b>C1 ~ C3</b>



## History of This Test Report

REPORT NO.	VERSION	DESCRIPTION	ISSUED DATE
FR322315AA	Rev. 01	Initial issue of report	Mar. 14, 2013



## 1. CERTIFICATE OF COMPLIANCE

**Product Name** : R6250 Smart WiFi Router  
**Brand Name** : NETGEAR  
**Model Name** : R6250  
**Applicant** : NETGEAR, Inc.  
**Test Rule Part(s)** : 47 CFR FCC Part 15 Subpart C § 15.247

Sporton International as requested by the applicant to evaluate the EMC performance of the product sample received on Jan. 07, 2013 would like to declare that the tested sample has been evaluated and found to be in compliance with the tested rule parts. The data recorded as well as the test configuration specified is true and accurate for showing the sample's EMC nature.

A handwritten signature in blue ink that reads 'Sam Chen' is written over a horizontal line.

**Sam Chen**

**SPORTON INTERNATIONAL INC.**

## 2. SUMMARY OF THE TEST RESULT

Applied Standard: 47 CFR FCC Part 15 Subpart C				
Part	Rule Section	Description of Test	Result	Under Limit
4.1	15.207	AC Power Line Conducted Emissions	Complies	6.12 dB
4.2	15.247(b)(3)	Maximum Conducted Output Power	Complies	2.81 dB
4.3	15.247(e)	Power Spectral Density	Complies	4.56 dB
4.4	15.247(a)(2)	6dB Spectrum Bandwidth	Complies	-
4.5	15.247(d)	Radiated Emissions	Complies	2.64 dB
4.6	15.247(d)	Band Edge Emissions	Complies	0.02 dB
4.7	15.203	Antenna Requirements	Complies	-

Test Items	Uncertainty	Remark
AC Power Line Conducted Emissions	±2.3dB	Confidence levels of 95%
Maximum Conducted Output Power	±0.8dB	Confidence levels of 95%
Power Spectral Density	±0.5dB	Confidence levels of 95%
6dB Spectrum Bandwidth	±8.5×10 <sup>-8</sup>	Confidence levels of 95%
Radiated Emissions (9kHz~30MHz)	±0.8dB	Confidence levels of 95%
Radiated Emissions (30MHz~1GHz)	±1.9dB	Confidence levels of 95%
Radiated / Band Edge Emissions (1GHz~18GHz)	±1.9dB	Confidence levels of 95%
Radiated Emissions (18GHz~40GHz)	±1.9dB	Confidence levels of 95%
Temperature	±0.7°C	Confidence levels of 95%
Humidity	±3.2%	Confidence levels of 95%
DC / AC Power Source	±1.4%	Confidence levels of 95%

### 3. GENERAL INFORMATION

#### 3.1. Product Details

##### IEEE 802.11n/ac

Items	Description
Product Type	IEEE 802.11n: For 2.4GHz Band: WLAN (2TX, 2RX) For 5GHz Band: WLAN (3TX, 3RX) IEEE 802.11ac: WLAN (3TX, 3RX)
Radio Type	Intentional Transceiver
Power Type	From Power Adapter
Modulation	see the below table for IEEE 802.11n/ac
Data Modulation	For 802.11n: OFDM (BPSK / QPSK / 16QAM / 64QAM) For 802.11ac: OFDM (BPSK / QPSK / 16QAM / 64QAM / 256QAM)
Data Rate (Mbps)	see the below table for IEEE 802.11n
Frequency Range	2400 ~ 2483.5MHz / 5725 ~ 5850MHz
Channel Number	For 2.4GHz Band: 11 for 20MHz bandwidth ; 7 for 40MHz bandwidth For 5GHz Band: 5 for 20MHz bandwidth ; 2 for 40MHz bandwidth ; 1 for 80MHz bandwidth
Channel Band Width (99%)	For 2.4GHz Band: MCS0 (20MHz): 17.44 MHz ; MCS0 (40MHz): 36.16 MHz For 5GHz Band: MCS0 (20MHz): 24.16 MHz ; MCS0 (40MHz): 46.72 MHz ; MCS0 (80MHz): 88.00 MHz
Maximum Conducted Output Power	For 2.4GHz Band: MCS0 (20MHz): 25.09 dBm ; MCS0 (40MHz): 20.48 dBm For 5GHz Band: <b>IEEE 802.11n:</b> MCS0 (20MHz): 26.99 dBm ; MCS0 (40MHz): 26.96 dBm <b>IEEE 802.11ac:</b> MCS0 (20MHz): 27.19 dBm ; MCS0 (40MHz): 27.11 dBm ; MCS0 (80MHz): 26.83 dBm
Carrier Frequencies	Please refer to section 3.4
Antenna	Please refer to section 3.3
The EUT supports beamforming mode for 802.11 ac 20/40/80MHz.	

**IEEE 802.11a/b/g**

Items	Description
Product Type	IEEE 802.11a: WLAN (3TX, 3RX) IEEE 802.11b: WLAN (1TX, 2RX) IEEE 802.11g: WLAN (2TX, 2RX)
Radio Type	Intentional Transceiver
Power Type	From Power Adapter
Modulation	DSSS for IEEE 802.11b ; OFDM for IEEE 802.11a/g
Data Modulation	DSSS (BPSK / QPSK / CCK) ; OFDM (BPSK / QPSK / 16QAM / 64QAM)
Data Rate (Mbps)	DSSS (1/ 2/ 5.5/11) ; OFDM (6/9/12/18/24/36/48/54)
Frequency Range	2400 ~ 2483.5MHz / 5725 ~ 5850MHz
Channel Number	11b/g: 11 ; 11a: 5
Channel Band Width (99%)	11b: 11.36 MHz ; 11g: 16.08 MHz ; 11a: 25.04 MHz
Maximum Conducted Output Power	11b: 25.39 dBm ; 11g: 26.24 dBm ; 11a: 26.84 dBm
Carrier Frequencies	Please refer to section 3.4
Antenna	Please refer to section 3.3

**Antenna & Band width**

Antenna	Single (TX)	Two (TX)		Three (TX)		
		20 MHz	40 MHz	20 MHz	40 MHz	80 MHz
IEEE 802.11a	X	X	X	V	X	X
IEEE 802.11b	V	X	X	X	X	X
IEEE 802.11g	X	V	X	X	X	X
IEEE 802.11n	X	V	V	V	V	X
IEEE 802.11ac	X	X	X	V	V	V

## IEEE 802.11n spec

MCS	Spatial	Modulation	Coding	Data rate (Mbit/s)			
Index	Streams	Type	Rate	20 MHz channel		40 MHz channel	
				800 ns GI	400 ns GI	800 ns GI	400 ns GI
0	1	BPSK	1/2	6.5	7.2	13.5	15
1	1	QPSK	1/2	13	14.4	27	30
2	1	QPSK	3/4	19.5	21.7	40.5	45
3	1	16-QAM	1/2	26	28.9	54	60
4	1	16-QAM	3/4	39	43.3	81	90
5	1	64-QAM	2/3	52	57.8	108	120
6	1	64-QAM	3/4	58.5	65	121.5	135
7	1	64-QAM	5/6	65	72.2	135	150
8	2	BPSK	1/2	13	14.4	27	30
9	2	QPSK	1/2	26	28.9	54	60
10	2	QPSK	3/4	39	43.3	81	90
11	2	16-QAM	1/2	52	57.8	108	120
12	2	16-QAM	3/4	78	86.7	162	180
13	2	64-QAM	2/3	104	115.6	216	240
14	2	64-QAM	3/4	117	130	243	270
15	2	64-QAM	5/6	130	144.4	270	300
16	3	BPSK	1/2	19.5	21.7	40.5	45
17	3	QPSK	1/2	39	43.3	81	90
18	3	QPSK	3/4	58.5	65	121.5	135
19	3	16-QAM	1/2	78	86.7	162	180
20	3	16-QAM	3/4	117	130	243	270
21	3	64-QAM	2/3	156	173.3	324	360
22	3	64-QAM	3/4	175.5	195	364.5	405
23	3	64-QAM	5/6	195	216.7	405	450

Symbol	Explanation
NSS	Number of spatial streams
R	Code rate
NBPSC	Number of coded bits per single carrier
NCBPS	Number of coded bits per symbol
NDBPS	Number of data bits per symbol
GI	guard interval



**IEEE 802. 11a, 11n and 11ac Spec.**

Worst Modulation Used for Conformance Testing				
Protocol	Number of Transmit Chains (NTX)	Data Rate / MCS	Worst Data Rate / MCS	Worst Modulation Mode
802.11a	3	6-54 Mbps	6Mbps	11A5.8G-20M
802.11n 20MHz	3	MCS 0-23	MCS 0	11N5.8G-20M
802.11n 40MHz	3	MCS 0-23	MCS 0	11N5.8G-40M
802.11ac 20MHz	3	MCS 0-9, Nss1-3	MCS 0-Nss1	11AC5.8G-20M
802.11ac 40MHz	3	MCS 0-9, Nss1-3	MCS 0-Nss1	11AC5.8G-40M
802.11ac 80MHz	3	MCS 0-9, Nss1-3	MCS 0-Nss1	11AC5.8G-80M
Note 1: IEEE 802.11 modulation consists of IEEE 802.11a.				
Note 2: IEEE 802.11n modulation consists of HT20 and HT40 (HT: High Throughput). Then EUT support HT20 and HT40. Worst modulation mode of Guard Interval (GI) is 400ns.				
Note 3: IEEE 802.11ac modulation consists of VHT20, VHT40, VHT80 and VHT160. Then EUT support VHT20, VHT40, VHT80. (VHT: Very High Throughput).				
Note 4: Modulation modes consist of 11A5.8G-20M, 11N5.8G-20M, 11N5.8G-40M, 11AC5.8G-20M, 11AC5.8G-40M, 11AC5.8G-80M				
Note 5: 11A: IEEE 802.11a, 11N: IEEE 802.11n, 11AC: IEEE 802.11ac. 5.8G: 5.725-5.850GHz band				
Note 6: 20M/40M/80M: Channel Bandwidth 20MHz/40MHz/80MHz				

**3.2. Accessories**

Power	Brand	Model	P/N	Rating
Adapter 1	NETGEAR	MU30-5120250-A1	332-10234-01	Input:100-240Vac, 50/60Hz, 0.8A Output:12Vdc, 2.5A
Adapter 2	NETGEAR	P030WF120B 11200-6LF	332-10200-02	Input:100-240Vac, 50/60Hz, 1.0A Output:12Vdc, 2.5A
Others				
RJ-45 Cable*1: Shielded, 1.3m				

### 3.3. Table for Filed Antenna

Ant.	Brand	Model Name	Antenna Type	Connector	Gain (dBi)	
					2.4GHz	5GHz
1	NETGEAR	-	PCB Antenna	I-PEX	1.5	-
2	NETGEAR	-	PCB Antenna	I-PEX	1.3	-
3	NETGEAR	-	PCB Antenna	I-PEX	-	2.5
4	NETGEAR	-	PCB Antenna	I-PEX	-	2.1
5	NETGEAR	-	PCB Antenna	I-PEX	-	3.0

Note: The EUT has five antennas

**<For 2.4GHz Band:>**

**For IEEE 802.11b mode (1TX/2RX)**

Only Ant. 2 can be used as transmitting, but Ant. 1 and Ant. 2 could receive simultaneously.

**For IEEE 802.11g/n mode (2TX/2RX)**

Ant. 1 and Ant. 2 could transmit/receive simultaneously.

**<For 5GHz Band:>**

**For IEEE 802.11a/n/ac mode (3TX/3RX):**

Ant. 3, Ant. 4 and Ant. 5 could transmit/receive simultaneously.

According to the above antennas, there are three antennas will transit simultaneously (one is Horizontal and the others are Vertical)

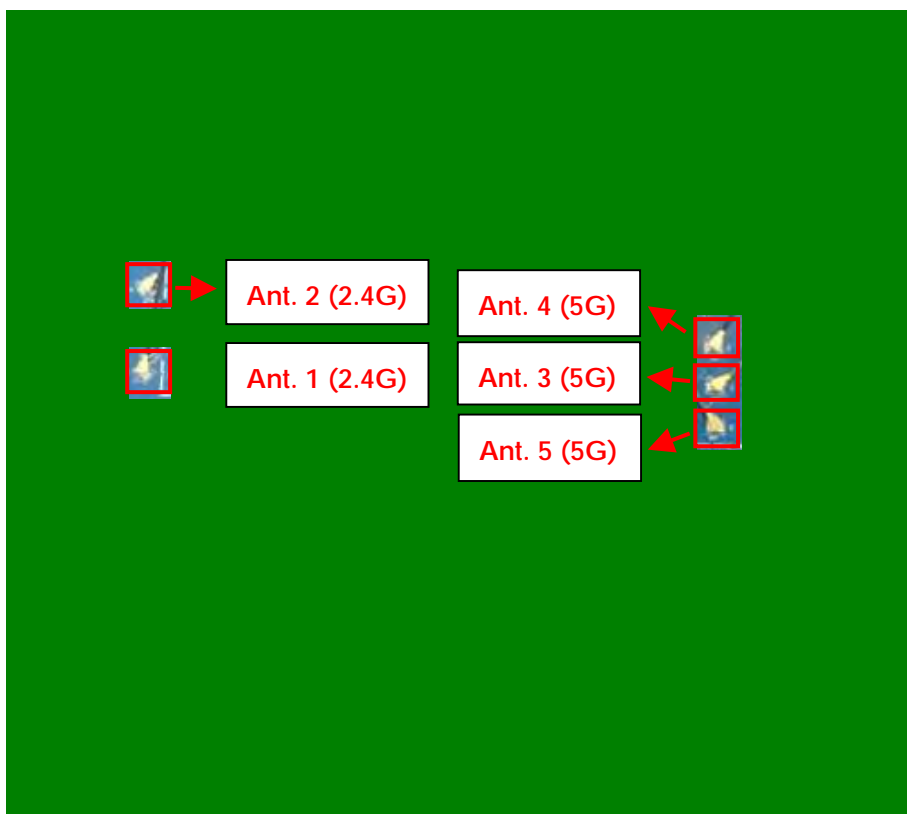

### 3.4. Table for Carrier Frequencies

#### For 2.4GHz Band:

There are two bandwidth systems.

For both 20MHz bandwidth systems, use Channel 1~Channel 11.

For both 40MHz bandwidth systems, use Channel 3~Channel 9.

Frequency Band	Channel No.	Frequency	Channel No.	Frequency
2400~2483.5MHz	1	2412 MHz	7	2442 MHz
	2	2417 MHz	8	2447 MHz
	3	2422 MHz	9	2452 MHz
	4	2427 MHz	10	2457 MHz
	5	2432 MHz	11	2462 MHz
	6	2437 MHz	-	-

#### For 5GHz Band:

There are three bandwidth systems.

For 20MHz bandwidth systems, use Channel 149, 153, 157, 161, 165.

For 40MHz bandwidth systems, use Channel 151, 159.

For 80MHz bandwidth systems, use Channel 155.

Frequency Band	Channel No.	Frequency	Channel No.	Frequency
5725~5850 MHz Band 4	149	5745 MHz	157	5785 MHz
	151	5755 MHz	159	5795 MHz
	153	5765 MHz	161	5805 MHz
	155	5775 MHz	165	5825 MHz

### 3.5. Table for Test Modes

Preliminary tests were performed in different data rate to find the worst radiated emission. The data rate shown in the table below is the worst-case rate with respect to the specific test item. Investigation has been done on all the possible configurations for searching the worst cases. The following table is a list of the test modes shown in this test report.

#### For 2.4GHz Band

Test Items	Mode	Data Rate	Channel	Antenna
AC Power Line Conducted Emissions	Normal Link	Auto	-	-
Maximum Conducted Output Power	MCS0/20MHz	6.5 Mbps	1/6/11	1+2
	MCS0/40MHz	13.5 Mbps	3/6/9	1+2
	11b/CCK	1 Mbps	1/6/11	2
	11g/BPSK	6 Mbps	1/6/11	1+2
Power Spectral Density	MCS0/20MHz	6.5 Mbps	1/6/11	1+2
	MCS0/40MHz	13.5 Mbps	3/6/9	1+2
	11b/CCK	1 Mbps	1/6/11	2
	11g/BPSK	6 Mbps	1/6/11	1+2
6dB Spectrum Bandwidth	MCS0/20MHz	6.5 Mbps	1/6/11	1+2
	MCS0/40MHz	13.5 Mbps	3/6/9	1+2
	11b/CCK	1 Mbps	1/6/11	2
	11g/BPSK	6 Mbps	1/6/11	1+2
Radiated Emissions Below 1GHz	Normal Link	Auto	-	-
Radiated Emissions Above 1GHz	MCS0/20MHz	6.5 Mbps	1/6/11	1+2
	MCS0/40MHz	13.5 Mbps	3/6/9	1+2
	11b/CCK	1 Mbps	1/6/11	2
	11g/BPSK	6 Mbps	1/6/11	1+2
Band Edge Emissions	MCS0/20MHz	6.5 Mbps	1/6/11	1+2
	MCS0/40MHz	13.5 Mbps	3/6/9	1+2
	11b/CCK	1 Mbps	1/6/11	2
	11g/BPSK	6 Mbps	1/6/11	1+2

**For 5GHz Band**

Test Items	Mode	Data Rate	Channel	Antenna
AC Power Line Conducted Emissions	Normal Link	Auto	-	-
Maximum Conducted Output Power	MCS0/20MHz	6.5 Mbps	149/157/165	3+4+5
	MCS0/40MHz	13.5 Mbps	151/159	3+4+5
	MCS0/80MHz	Nss1	155	3+4+5
	11a/BPSK	6 Mbps	149/157/165	3+4+5
Power Spectral Density	MCS0/20MHz	6.5 Mbps	149/157/165	3+4+5
	MCS0/40MHz	13.5 Mbps	151/159	3+4+5
	MCS0/80MHz	Nss1	155	3+4+5
	11a/BPSK	6 Mbps	149/157/165	3+4+5
6dB Spectrum Bandwidth	MCS0/20MHz	6.5 Mbps	149/157/165	3+4+5
	MCS0/40MHz	13.5 Mbps	151/159	3+4+5
	MCS0/80MHz	Nss1	155	3+4+5
	11a/BPSK	6 Mbps	149/157/165	3+4+5
Radiated Emissions Below 1GHz	Normal Link	Auto	-	-
Radiated Emissions Above 1GHz	MCS0/20MHz	6.5 Mbps	149/157/165	3+4+5
	MCS0/40MHz	13.5 Mbps	151/159	3+4+5
	MCS0/80MHz	Nss1	155	3+4+5
	11a/BPSK	6 Mbps	149/157/165	3+4+5
Band Edge Emissions	MCS0/20MHz	6.5 Mbps	149/157/165	3+4+5
	MCS0/40MHz	13.5 Mbps	151/159	3+4+5
	MCS0/80MHz	Nss1	155	3+4+5
	11a/BPSK	6 Mbps	149/157/165	3+4+5

Beamforming mode is worse case than non-beamforming mode so that it is representative and recorded in the test report.

The following test modes were performed for all tests:

**For Conducted Emission test:**

Mode 1. EUT + Power Adapter 1

Mode 2. EUT + Power Adapter 2

Due to Mode 1 generated the worst test result, so it was recorded in this report.

**For Radiated Emission test:**

Mode 1. EUT + Power Adapter 1

Mode 2. EUT + Power Adapter 2

Due to Mode 2 generated the worst test result, it was recorded in this report.

**<For MPE and Co-location Test>:**

The EUT could be applied with 2.4GHz WLAN function and 5GHz WLAN function; therefore Maximum Permissible Exposure (Please refer to Appendix B) and Co-location (please refer to Appendix C) tests are added for simultaneously transmit between 2.4GHz WLAN function and 5GHz WLAN function.

### 3.6. Table for Testing Locations

Test Site No.	Site Category	Location	FCC Reg. No.	IC File No.
03CH01-CB	SAC	Hsin Chu	262045	IC 4086D
CO01-CB	Conduction	Hsin Chu	262045	IC 4086D
TH01-CB	OVEN Room	Hsin Chu	-	-

Open Area Test Site (OATS); Semi Anechoic Chamber (SAC).

Please refer section 6 for Test Site Address.

### 3.7. Table for Supporting Units

Support Unit	Brand	Model	FCC ID
Notebook	DELL	E6220	QDS-BRCM1049LE
Mouse	Logitech M90	M-U0026	DoC
Earphone	SHYARO CHI	MIC-04	N/A
Flash Disk	ADATA	C103	DoC
Notebook	DELL	E6220	QDS-BRCM1049LE
Notebook	DELL	E6430	QDS-BRCM1049LE
Notebook	DELL	E6430	QDS-BRCM1049LE

### 3.8. Table for Parameters of Test Software Setting

During testing, Channel & Power Controlling Software provided by the customer was used to control the operating channel as well as the output power level. The RF output power selection is for the setting of RF output power expected by the customer and is going to be fixed on the firmware of the final end product.

#### For 2.4GHz Band

##### Power Parameters of IEEE 802.11n MCS0 20MHz / Ant. 1 + Ant. 2 (2TX)

Test Software Version	Manual Tool Version : 1.0.0.10		
Frequency	2412 MHz	2437 MHz	2462 MHz
MCS0 20MHz	64	90	66

##### Power Parameters of IEEE 802.11n MCS0 40MHz / Ant. 1 + Ant. 2 (2TX)

Test Software Version	Manual Tool Version : 1.0.0.10		
Frequency	2422 MHz	2437 MHz	2452 MHz
MCS0 40MHz	52	71	55

##### Power Parameters of IEEE 802.11b / Ant. 2 (1TX)

Test Software Version	Manual Tool Version : 1.0.0.10		
Frequency	2412 MHz	2437 MHz	2462 MHz
IEEE 802.11b	78	99	83

##### Power Parameters of IEEE 802.11g / Ant. 1 + Ant. 2 (2TX)

Test Software Version	Manual Tool Version : 1.0.0.10		
Frequency	2412 MHz	2437 MHz	2462 MHz
IEEE 802.11g	70	97	67

**For 5GHz Band**
**Power Parameters of IEEE 802.11n MCS0 20MHz / Ant. 3 + Ant. 4 + Ant. 5 (3TX)**

Test Software Version	Manual Tool Version : 1.0.0.10		
Frequency	5745 MHz	5785 MHz	5825 MHz
MCS0 20MHz	100	100	100

**Power Parameters of IEEE 802.11n MCS0 40MHz / Ant. 3 + Ant. 4 + Ant. 5 (3TX)**

Test Software Version	Manual Tool Version : 1.0.0.10	
Frequency	5755 MHz	5795 MHz
MCS0 40MHz	100	100

**Power Parameters of IEEE 802.11ac MCS0 20MHz / Ant. 3 + Ant. 4 + Ant. 5 (3TX)**

Test Software Version	Manual Tool Version : 1.0.0.10		
Frequency	5745 MHz	5785 MHz	5825 MHz
MCS0 20MHz	100	100	100

**Power Parameters of IEEE 802.11ac MCS0 40MHz / Ant. 3 + Ant. 4 + Ant. 5 (3TX)**

Test Software Version	Manual Tool Version : 1.0.0.10	
Frequency	5755 MHz	5795 MHz
MCS0 40MHz	100	100

**Power Parameters of IEEE 802.11ac MCS0 80MHz / Ant. 3 + Ant. 4 + Ant. 5 (3TX)**

Test Software Version	Manual Tool Version : 1.0.0.10	
Frequency	5775 MHz	
MCS0 80MHz	100	

**Power Parameters of IEEE 802.11a / Ant. 3 + Ant. 4 + Ant. 5 (3TX)**

Test Software Version	Manual Tool Version : 1.0.0.10		
Frequency	5745 MHz	5785 MHz	5825 MHz
IEEE 802.11a	100	100	100

During the test, "Manual Tool Version : 1.0.0.10" under WIN XP was executed the test program to control the EUT continuously transmit RF signal.



### 3.9. Test Configurations

#### 3.9.1. Radiation Emissions Test Configuration

Test Configuration: 30MHz~1GHz / Test Mode: Mode 2.

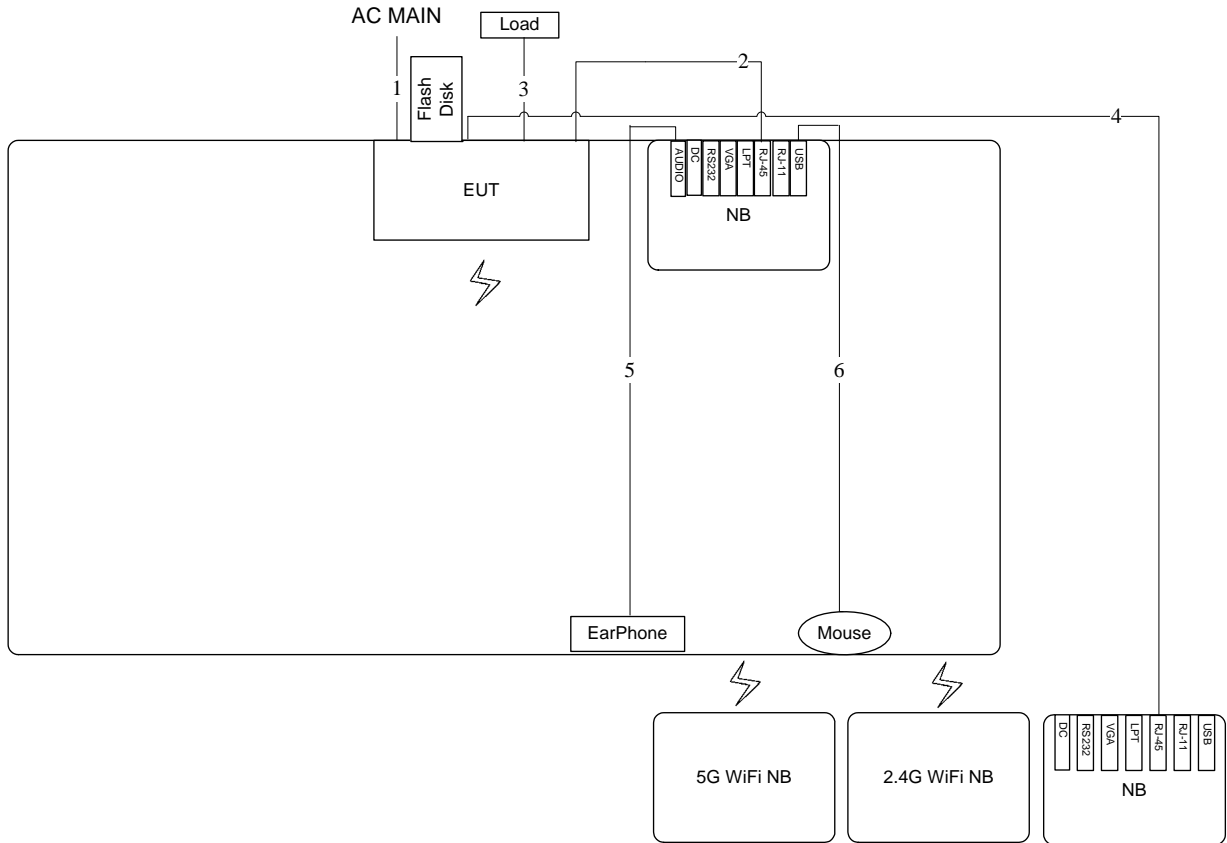

Item	Connection	Shield	Length
1	Power cable	No	1.8m
2	RJ-45 cable	Yes	1.5m
3	RJ-45 cable*3	No	1.5m
4	RJ-45 cable	No	10m
5	Audio cable	No	1.1m
6	USB cable	No	1.8m

Test Configuration: above 1GHz / Test Mode: Mode 2.

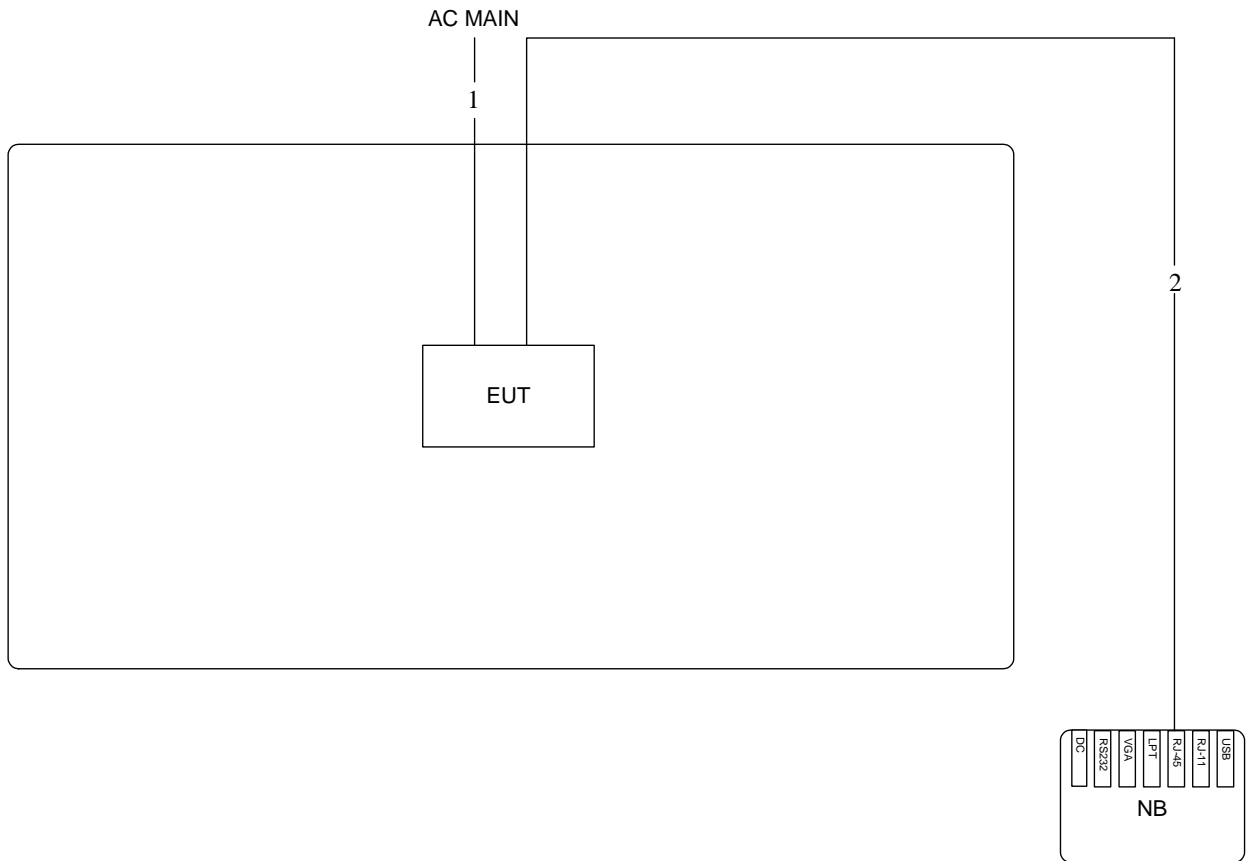

Item	Connection	Shield	Length
1	Power cable	No	1.8m
2	RJ-45 cable	No	10m

### 3.9.2. AC Power Line Conduction Emissions Test Configuration

Test Mode: Mode 1.

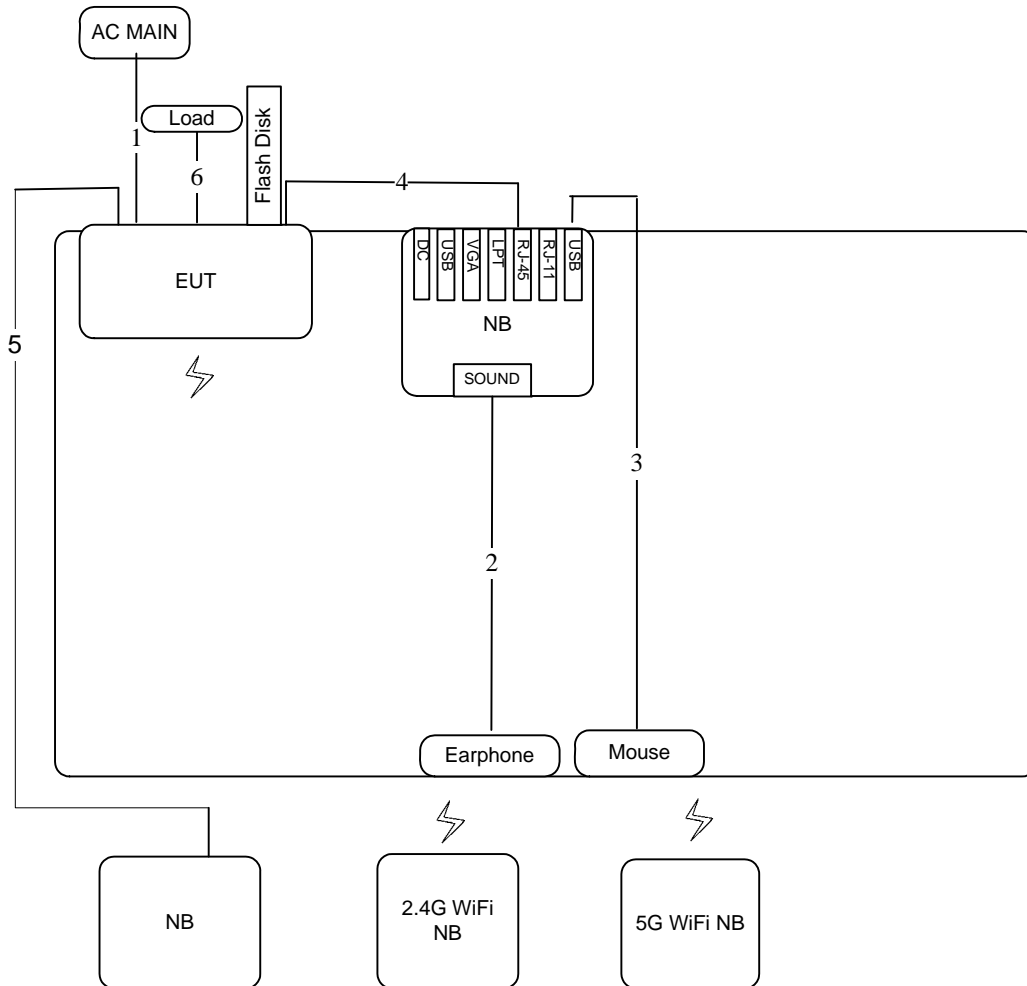

Item	Connection	Shield	Length
1	Power cable	No	1.8m
2	Audio cable	No	1.1m
3	USB cable	No	1.8m
4	RJ-45	Yes	1.5m
5	RJ-45	No	10m
6	RJ-45*3	No	1.5m

## 4. TEST RESULT

### 4.1. AC Power Line Conducted Emissions Measurement

#### 4.1.1. Limit

For this product which is designed to be connected to the AC power line, the radio frequency voltage that is conducted back onto the AC power line on any frequency or frequencies within the band 150 kHz to 30 MHz shall not exceed below limits table.

Frequency (MHz)	QP Limit (dBuV)	AV Limit (dBuV)
0.15~0.5	66~56	56~46
0.5~5	56	46
5~30	60	50

#### 4.1.2. Measuring Instruments and Setting

Please refer to section 5 of equipments list in this report. The following table is the setting of the receiver.

Receiver Parameters	Setting
Attenuation	10 dB
Start Frequency	0.15 MHz
Stop Frequency	30 MHz
IF Bandwidth	9 KHz

#### 4.1.3. Test Procedures

1. Configure the EUT according to ANSI C63.10. The EUT or host of EUT has to be placed 0.4 meter far from the conducting wall of the shielding room and at least 80 centimeters from any other grounded conducting surface.
2. Connect EUT or host of EUT to the power mains through a line impedance stabilization network (LISN).
3. All the support units are connected to the other LISNs. The LISN should provide 50uH/50ohms coupling impedance.
4. The frequency range from 150 KHz to 30 MHz was searched.
5. Set the test-receiver system to Peak Detect Function and Specified Bandwidth with Maximum Hold Mode.
6. The measurement has to be done between each power line and ground at the power terminal.

#### 4.1.4. Test Setup Layout

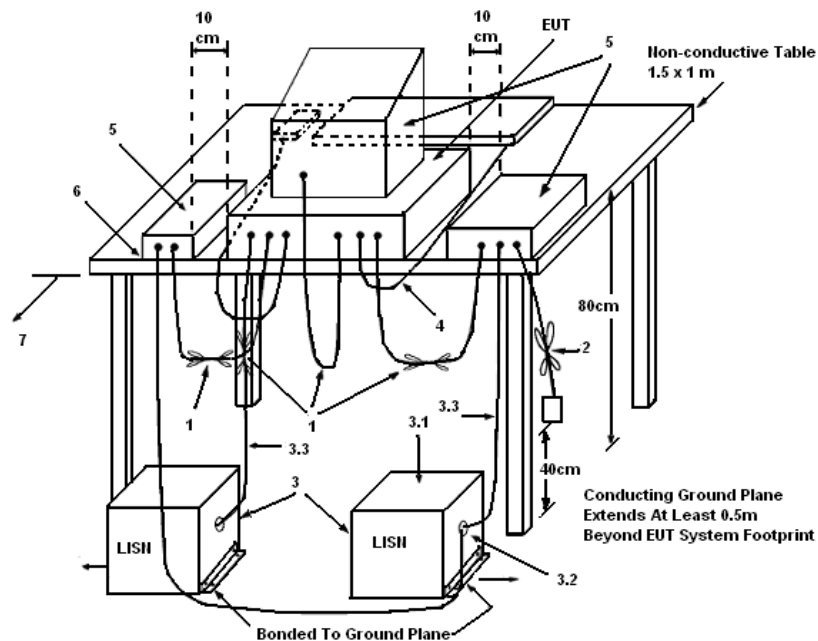

#### LEGEND:

- (1) Interconnecting cables that hang closer than 40 cm to the ground plane shall be folded back and forth in the center forming a bundle 30 to 40 cm long.
- (2) I/O cables that are not connected to a peripheral shall be bundled in the center. The end of the cable may be terminated, if required, using the correct terminating impedance. The overall length shall not exceed 1 m.
- (3) EUT connected to one LISN. Unused LISN measuring port connectors shall be terminated in 50  $\Omega$ . LISN can be placed on top of, or immediately beneath, reference ground plane.
  - (3.1) All other equipment powered from additional LISN(s).
  - (3.2) Multiple outlet strip can be used for multiple power cords of non-EUT equipment.
  - (3.3) LISN at least 80 cm from nearest part of EUT chassis.
- (4) Cables of hand-operated devices, such as keyboards, mice, etc., shall be placed as for normal use.
- (5) Non-EUT components of EUT system being tested.
- (6) Rear of EUT, including peripherals, shall all be aligned and flush with rear of tabletop.
- (7) Rear of tabletop shall be 40 cm removed from a vertical conducting plane that is bonded to the ground plane.

#### 4.1.5. Test Deviation

There is no deviation with the original standard.

#### 4.1.6. EUT Operation during Test

The EUT was placed on the test table and programmed in normal function.

4.1.7. Results of AC Power Line Conducted Emissions Measurement

Temperature	22°C	Humidity	52.4%
Test Engineer	Yeh Hsieh	Phase	Line
Configuration	Normal Link	Test Mode	Mode 1. EUT + Power Adapter 1

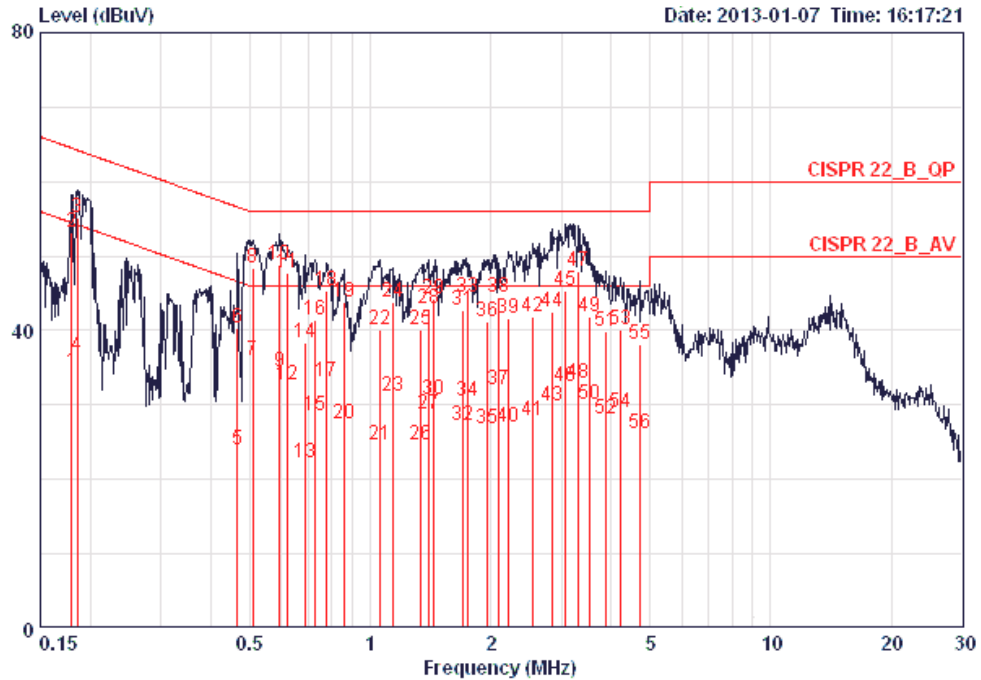

	Freq	Level	Over	Limit	Read	LISN	Cable	Remark
	MHz	dBuV	Limit	Line	Level	Factor	Loss	
			dB	dBuV	dBuV	dB	dB	
1	0.17961	34.35	-20.15	54.50	34.01	0.15	0.19	AVERAGE
2	0.17961	53.27	-11.23	64.50	52.93	0.15	0.19	QP
3	0.18541	55.23	-9.01	64.24	54.89	0.15	0.19	QP
4	0.18541	36.71	-17.53	54.24	36.37	0.15	0.19	AVERAGE
5	0.46614	24.08	-22.50	46.58	23.73	0.15	0.20	AVERAGE
6	0.46614	40.34	-16.24	56.58	39.99	0.15	0.20	QP
7	0.51007	35.97	-10.03	46.00	35.62	0.15	0.20	AVERAGE
8	0.51007	48.39	-7.61	56.00	48.04	0.15	0.20	QP
9	0.59478	34.40	-11.60	46.00	34.04	0.16	0.20	AVERAGE
10	0.59478	48.73	-7.27	56.00	48.37	0.16	0.20	QP
11	0.62054	47.70	-8.30	56.00	47.34	0.16	0.20	QP
12	0.62054	32.68	-13.32	46.00	32.32	0.16	0.20	AVERAGE
13	0.68626	22.30	-23.70	46.00	21.94	0.16	0.20	AVERAGE
14	0.68626	38.29	-17.71	56.00	37.93	0.16	0.20	QP
15	0.72744	28.55	-17.45	46.00	28.19	0.16	0.20	AVERAGE
16	0.72744	41.41	-14.59	56.00	41.05	0.16	0.20	QP
17	0.77931	33.19	-12.81	46.00	32.83	0.16	0.20	AVERAGE
18	0.77931	45.34	-10.66	56.00	44.98	0.16	0.20	QP
19	0.85730	43.86	-12.15	56.00	43.49	0.17	0.20	QP
20	0.85730	27.57	-18.44	46.00	27.20	0.17	0.20	AVERAGE
21	1.054	24.65	-21.35	46.00	24.28	0.17	0.20	AVERAGE
22	1.054	40.06	-15.94	56.00	39.69	0.17	0.20	QP
23	1.135	31.10	-14.90	46.00	30.72	0.17	0.21	AVERAGE
24	1.135	43.75	-12.25	56.00	43.37	0.17	0.21	QP
25	1.331	40.12	-15.88	56.00	39.73	0.18	0.21	QP



	Freq	Level	Over Limit	Limit Line	Read Level	LISN Factor	Cable Loss	Remark
	MHz	dBuV	dB	dBuV	dBuV	dB	dB	
26	0.86643	43.62	-12.38	56.00	43.33	0.09	0.20	QP
27	1.037	32.64	-13.36	46.00	32.35	0.09	0.20	AVERAGE
28	1.037	45.76	-10.24	56.00	45.47	0.09	0.20	QP
29	1.117	44.99	-11.01	56.00	44.69	0.09	0.20	QP
30	1.117	31.08	-14.92	46.00	30.78	0.09	0.20	AVERAGE
31	1.197	24.61	-21.39	46.00	24.31	0.09	0.21	AVERAGE
32	1.197	41.22	-14.78	56.00	40.92	0.09	0.21	QP
33	1.345	44.83	-11.17	56.00	44.52	0.10	0.21	QP
34	1.345	31.95	-14.05	46.00	31.64	0.10	0.21	AVERAGE
35	1.464	44.38	-11.62	56.00	44.06	0.10	0.22	QP
36	1.464	29.37	-16.63	46.00	29.05	0.10	0.22	AVERAGE
37	1.636	45.16	-10.84	56.00	44.84	0.10	0.22	QP
38	1.636	30.90	-15.10	46.00	30.58	0.10	0.22	AVERAGE
39	1.781	30.02	-15.98	46.00	29.69	0.11	0.23	AVERAGE
40	1.781	43.92	-12.08	56.00	43.59	0.11	0.23	QP
41	1.970	31.69	-14.31	46.00	31.35	0.11	0.23	AVERAGE
42	1.970	45.47	-10.53	56.00	45.13	0.11	0.23	QP
43	2.309	46.09	-9.91	56.00	45.74	0.11	0.24	QP
44	2.309	33.39	-12.61	46.00	33.04	0.11	0.24	AVERAGE
45	2.500	45.18	-10.82	56.00	44.82	0.12	0.24	QP
46	2.500	31.50	-14.50	46.00	31.14	0.12	0.24	AVERAGE
47	2.900	33.30	-12.70	46.00	32.93	0.12	0.25	AVERAGE
48	2.900	46.77	-9.23	56.00	46.40	0.12	0.25	QP
49	3.258	48.31	-7.69	56.00	47.92	0.12	0.26	QP
50	3.258	32.95	-13.05	46.00	32.56	0.12	0.26	AVERAGE
51	4.269	31.85	-14.15	46.00	31.41	0.13	0.31	AVERAGE
52	4.269	42.88	-13.12	56.00	42.44	0.13	0.31	QP
53	4.874	29.69	-16.31	46.00	29.23	0.15	0.32	AVERAGE
54	4.874	39.74	-16.26	56.00	39.28	0.15	0.32	QP

Temperature	22°C	Humidity	52.4%
Test Engineer	Yeh Hsieh	Phase	Neutral
Configuration	Normal Link	Test Mode	Mode 1. EUT + Power Adapter 1

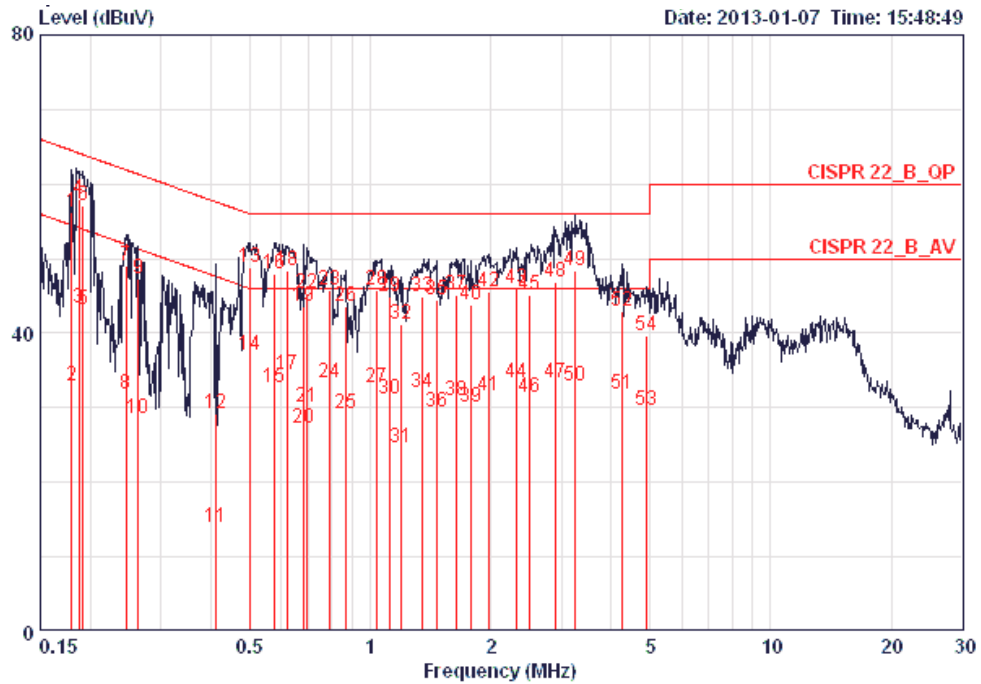

	Freq	Level	Over Limit	Limit Line	Read Level	LISN Factor	Cable Loss	Remark
	MHz	dBuV	dB	dBuV	dBuV	dB	dB	
1	0.17961	56.15	-8.35	64.50	55.88	0.08	0.19	QP
2	0.17961	32.88	-21.62	54.50	32.61	0.08	0.19	AVERAGE
3	0.18739	43.45	-10.71	54.15	43.17	0.08	0.20	AVERAGE
4	0.18739	58.04	-6.12	64.15	57.76	0.08	0.20	QP
5	0.19140	43.06	-10.92	53.98	42.78	0.08	0.20	AVERAGE
6	0.19140	57.19	-6.79	63.98	56.91	0.08	0.20	QP
7	0.24552	49.07	-12.84	61.91	48.79	0.08	0.20	QP
8	0.24552	31.75	-20.16	51.91	31.47	0.08	0.20	AVERAGE
9	0.26303	47.24	-14.10	61.34	46.96	0.08	0.20	QP
10	0.26303	28.63	-22.71	51.34	28.35	0.08	0.20	AVERAGE
11	0.41266	13.87	-33.72	47.59	13.59	0.08	0.20	AVERAGE
12	0.41266	29.28	-28.31	57.59	29.00	0.08	0.20	QP
13	0.49937	48.92	-7.09	56.01	48.64	0.08	0.20	QP
14	0.49937	37.08	-8.93	46.01	36.80	0.08	0.20	AVERAGE
15	0.57617	32.71	-13.29	46.00	32.43	0.08	0.20	AVERAGE
16	0.57617	47.94	-8.06	56.00	47.66	0.08	0.20	QP
17	0.62054	34.41	-11.59	46.00	34.13	0.08	0.20	AVERAGE
18	0.62054	48.33	-7.67	56.00	48.05	0.08	0.20	QP
19	0.68263	43.53	-12.47	56.00	43.25	0.08	0.20	QP
20	0.68263	27.35	-18.65	46.00	27.07	0.08	0.20	AVERAGE
21	0.69725	30.04	-15.97	46.00	29.75	0.09	0.20	AVERAGE
22	0.69725	45.40	-10.61	56.00	45.11	0.09	0.20	QP
23	0.79180	45.69	-10.31	56.00	45.40	0.09	0.20	QP
24	0.79180	33.28	-12.72	46.00	32.99	0.09	0.20	AVERAGE
25	0.86643	29.28	-16.72	46.00	28.99	0.09	0.20	AVERAGE





	Freq	Level	Over Limit	Limit Line	Read Level	LISN Factor	Cable Loss	Remark
	MHz	dBuV	dB	dBuV	dBuV	dB	dB	
26	1.331	24.54	-21.46	46.00	24.15	0.18	0.21	AVERAGE
27	1.396	28.72	-17.28	46.00	28.33	0.18	0.21	AVERAGE
28	1.396	42.98	-13.02	56.00	42.59	0.18	0.21	QP
29	1.441	44.17	-11.83	56.00	43.78	0.18	0.22	QP
30	1.441	30.81	-15.19	46.00	30.42	0.18	0.22	AVERAGE
31	1.707	42.66	-13.34	56.00	42.25	0.18	0.22	QP
32	1.707	27.16	-18.84	46.00	26.75	0.18	0.22	AVERAGE
33	1.753	44.41	-11.59	56.00	44.00	0.19	0.22	QP
34	1.753	30.48	-15.52	46.00	30.07	0.19	0.22	AVERAGE
35	1.959	26.84	-19.16	46.00	26.42	0.19	0.23	AVERAGE
36	1.959	41.26	-14.74	56.00	40.84	0.19	0.23	QP
37	2.088	32.01	-13.99	46.00	31.59	0.19	0.23	AVERAGE
38	2.088	44.41	-11.59	56.00	43.99	0.19	0.23	QP
39	2.213	41.60	-14.40	56.00	41.17	0.19	0.24	QP
40	2.213	26.99	-19.01	46.00	26.56	0.19	0.24	AVERAGE
41	2.554	27.84	-18.16	46.00	27.40	0.20	0.24	AVERAGE
42	2.554	41.93	-14.07	56.00	41.49	0.20	0.24	QP
43	2.854	29.89	-16.11	46.00	29.44	0.20	0.25	AVERAGE
44	2.854	42.43	-13.57	56.00	41.98	0.20	0.25	QP
45	3.074	45.29	-10.71	56.00	44.83	0.21	0.25	QP
46	3.074	32.37	-13.63	46.00	31.91	0.21	0.25	AVERAGE
47	3.293	47.98	-8.02	56.00	47.50	0.21	0.27	QP
48	3.293	32.95	-13.05	46.00	32.47	0.21	0.27	AVERAGE
49	3.528	41.90	-14.10	56.00	41.41	0.21	0.28	QP
50	3.528	30.03	-15.97	46.00	29.54	0.21	0.28	AVERAGE
51	3.860	39.86	-16.14	56.00	39.35	0.22	0.29	QP
52	3.860	28.15	-17.85	46.00	27.64	0.22	0.29	AVERAGE
53	4.202	40.19	-15.81	56.00	39.66	0.22	0.30	QP
54	4.202	28.90	-17.10	46.00	28.37	0.22	0.30	AVERAGE
55	4.696	38.12	-17.88	56.00	37.57	0.23	0.31	QP
56	4.696	26.17	-19.83	46.00	25.62	0.23	0.31	AVERAGE

Note:

Level = Read Level + LISN Factor + Cable Loss

## 4.2. Maximum Conducted Output Power Measurement

### 4.2.1. Limit

For systems using digital modulation in the 2400-2483.5MHz, the limit for output power is 30dBm. The limited has to be reduced by the amount in dB that the gain of the antenna exceed 6dBi. In case of point-to-point operation, the limit has to be reduced by 1dB for every 3dB that the directional gain of the antenna exceeds 6dBi. Systems operating in the 5725-5850 MHz band that are used exclusively for fixed, point-to-point operations may employ transmitting antennas with directional gain greater than 6 dBi without any corresponding reduction in transmitter output power.

### 4.2.2. Measuring Instruments and Setting

Please refer to section 5 of equipments list in this report. The following table is the setting of the power meter.

Power Meter Parameter	Setting
Detector	Average

### 4.2.3. Test Procedures

1. Test procedures refer KDB558074 v01 r02 section 8.2.3 option 3.
2. This procedure provides an alternative for determining the RMS output power using a broadband RF average power meter with a thermocouple detector.

### 4.2.4. Test Setup Layout

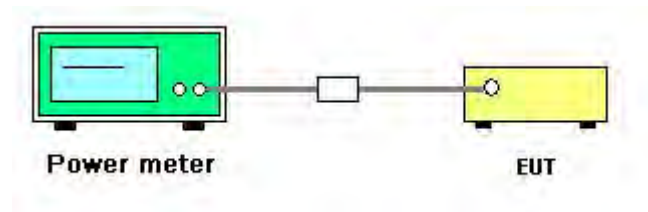

### 4.2.5. Test Deviation

There is no deviation with the original standard.

### 4.2.6. EUT Operation during Test

The EUT was programmed to be in continuously transmitting mode.

#### 4.2.7. Test Result of Maximum Conducted Output Power

Temperature	23°C	Humidity	63%
Test Engineer	Benson Peng	Configurations	IEEE 802.11n/ac
Test Date	Jan. 31, 2013		

##### For 2.4GHz Band

##### Configuration IEEE 802.11n MCS0 20MHz / Ant. 1 + Ant. 2 (2TX)

Channel	Frequency	Conducted Power (dBm)		Total Conducted Power (dBm)	Max. Limit (dBm)	Result
		Ant. 1	Ant. 2			
1	2412 MHz	15.98	15.35	18.69	30.00	Complies
6	2437 MHz	22.14	22.01	25.09	30.00	Complies
11	2462 MHz	16.43	16.59	19.52	30.00	Complies

##### Configuration IEEE 802.11n MCS0 40MHz / Ant. 1 + Ant. 2 (2TX)

Channel	Frequency	Conducted Power (dBm)		Total Conducted Power (dBm)	Max. Limit (dBm)	Result
		Ant. 1	Ant. 2			
3	2422 MHz	12.31	12.45	15.39	30.00	Complies
6	2437 MHz	17.18	17.75	20.48	30.00	Complies
9	2452 MHz	13.26	13.57	16.43	30.00	Complies

##### For 5GHz Band

##### Configuration IEEE 802.11n MCS0 20MHz / Ant. 3 + Ant. 4 + Ant. 5 (3TX)

Channel	Frequency	Conducted Power (dBm)			Total Conducted Power (dBm)	Max. Limit (dBm)	Result
		Ant. 3	Ant. 4	Ant. 5			
149	5745 MHz	21.85	21.79	22.93	26.99	30.00	Complies
157	5785 MHz	21.56	21.81	22.84	26.88	30.00	Complies
165	5825 MHz	21.47	21.67	22.71	26.76	30.00	Complies

##### Configuration IEEE 802.11n MCS0 40MHz / Ant. 3 + Ant. 4 + Ant. 5 (3TX)

Channel	Frequency	Conducted Power (dBm)			Total Conducted Power (dBm)	Max. Limit (dBm)	Result
		Ant. 3	Ant. 4	Ant. 5			
151	5755 MHz	21.82	21.84	22.83	26.96	30.00	Complies
159	5795 MHz	21.73	21.58	22.63	26.78	30.00	Complies

**Configuration IEEE 802.11ac MCS0 20MHz / Ant. 3 + Ant. 4 + Ant. 5 (3TX)**

Channel	Frequency	Conducted Power (dBm)			Total Conducted Power (dBm)	Max. Limit (dBm)	Result
		Ant. 3	Ant. 4	Ant. 5			
149	5745 MHz	21.92	22.01	23.21	27.19	30.00	Complies
157	5785 MHz	21.59	21.95	22.78	26.91	30.00	Complies
165	5825 MHz	21.62	21.81	22.82	26.89	30.00	Complies

Note: Directional gain= $G_{ANT} + 10 \log(N_{ANT}/N_{ss}) = 5.56 \text{ dBi} < 6 \text{ dBi}$ , so the limit doesn't reduce.

**Configuration IEEE 802.11ac MCS0 40MHz / Ant. 3 + Ant. 4 + Ant. 5 (3TX)**

Channel	Frequency	Conducted Power (dBm)			Total Conducted Power (dBm)	Max. Limit (dBm)	Result
		Ant. 3	Ant. 4	Ant. 5			
151	5755 MHz	21.98	22.09	22.89	27.11	30.00	Complies
159	5795 MHz	21.85	21.75	22.75	26.91	30.00	Complies

Note: Directional gain= $G_{ANT} + 10 \log(N_{ANT}/N_{ss}) = 5.56 \text{ dBi} < 6 \text{ dBi}$ , so the limit doesn't reduce.

**Configuration IEEE 802.11ac MCS0 80MHz / Ant. 3 + Ant. 4 + Ant. 5 (3TX)**

Channel	Frequency	Conducted Power (dBm)			Total Conducted Power (dBm)	Max. Limit (dBm)	Result
		Ant. 3	Ant. 4	Ant. 5			
155	5775 MHz	21.87	21.66	22.58	26.83	30.00	Complies

Note: Directional gain= $G_{ANT} + 10 \log(N_{ANT}/N_{ss}) = 5.56 \text{ dBi} < 6 \text{ dBi}$ , so the limit doesn't reduce.

Temperature	23°C	Humidity	63%
Test Engineer	Benson Peng	Configurations	IEEE 802.11a/b/g
Test Date	Jan. 31, 2013		

**Configuration IEEE 802.11b / Ant. 2 (1TX)**

Channel	Frequency	Conducted Power (dBm)	Max. Limit (dBm)	Result
1	2412 MHz	19.33	30.00	Complies
6	2437 MHz	25.39	30.00	Complies
11	2462 MHz	20.19	30.00	Complies

**Configuration IEEE 802.11g / Ant. 1 + Ant. 2 (2TX)**

Channel	Frequency	Conducted Power (dBm)		Total Conducted Power (dBm)	Max. Limit (dBm)	Result
		Ant. 1	Ant. 2			
1	2412 MHz	17.32	17.19	20.27	30.00	Complies
6	2437 MHz	23.39	23.07	26.24	30.00	Complies
11	2462 MHz	16.54	16.34	19.45	30.00	Complies

**Configuration IEEE 802.11a / Ant. 3 + Ant. 4 + Ant. 5 (3TX)**

Channel	Frequency	Conducted Power (dBm)			Total Conducted Power (dBm)	Max. Limit (dBm)	Result
		Ant. 3	Ant. 4	Ant. 5			
149	5745 MHz	21.53	21.72	22.84	26.84	30.00	Complies
157	5785 MHz	21.33	21.70	22.76	26.74	30.00	Complies
165	5825 MHz	21.31	21.66	22.77	26.73	30.00	Complies

### 4.3. Power Spectral Density Measurement

#### 4.3.1. Limit

For digitally modulated systems, the power spectral density conducted from the intentional radiator to the antenna shall not be greater than 8dBm in any 3 kHz band during any time interval of continuous transmission.

#### 4.3.2. Measuring Instruments and Setting

Please refer to section 5 of equipments list in this report. The following table is the setting of the spectrum analyzer.

Spectrum Parameter	Setting
Attenuation	Auto
Span Frequency	Set the span to 1.5 times the DTS channel bandwidth.
RB	$\geq 3$ kHz
VB	$\geq 3 \times$ RBW
Detector	Peak
Trace	Max Hold
Sweep Time	Auto couple

### 4.3.3. Test Procedures

1. Test procedures refer KDB558074 v01 r02 section 9.1 option 1 & KDB 662911 D01 Multiple Transmitter Output v01r02 section In-Band Power Spectral Density (PSD) Measurements option (2) Measure and add  $10 \log(NANT)$  dB
2. Use this procedure when the maximum conducted output power in the fundamental emission is used to demonstrate compliance. The EUT must be configured to transmit continuously at full power over the measurement duration.
3. Ensure that the number of measurement points in the sweep  $\geq 2 \times \text{span}/\text{RBW}$  (use of a greater number of measurement points than this minimum requirement is recommended).
4. Use the peak marker function to determine the maximum level in any 100 kHz band segment within the fundamental EBW.
5. Scale the observed power level to an equivalent level in 3 kHz by adjusting (reducing) the measured power by a bandwidth correction factor =  $10 \log(3 \text{ kHz}/100 \text{ kHz} = -15.2 \text{ dB})$ .
6. The resulting PSD level must be  $\leq 8 \text{ dBm}$ .
7. When measuring power spectral density with multiple antenna systems, add every result of the values by mathematic formula.

#### 4.3.4. Test Setup Layout

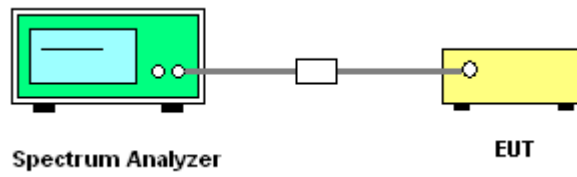

#### 4.3.5. Test Deviation

There is no deviation with the original standard.

#### 4.3.6. EUT Operation during Test

The EUT was programmed to be in continuously transmitting mode.



#### 4.3.7. Test Result of Power Spectral Density

Temperature	23°C	Humidity	63%
Test Engineer	Benson Peng	Configurations	IEEE 802.11n/ac

For 2.4GHz Band

Configuration IEEE 802.11n MCS0 20MHz / Ant. 1 + Ant. 2 (2TX)

Frequency	Power Density (dBm/100kHz)		Correction factor (100kHz to 3kHz)	Power Density (dBm/3kHz)		Single Port Limit (dBm/3kHz)	Result
	Ant. 1	Ant. 2		Ant. 1	Ant. 2		
2412 MHz	3.50	3.34	-15.23	-11.73	-11.89	4.99	Complies
2437 MHz	9.23	9.06	-15.23	-6.00	-6.17	4.99	Complies
2462 MHz	3.41	3.50	-15.23	-11.82	-11.73	4.99	Complies

Note: PSD Limit = (8dBm/3kHz - (10log(2)))=4.99dBm/3kHz

Configuration IEEE 802.11n MCS0 40MHz / Ant. 1 + Ant. 2 (2TX)

Frequency	Power Density (dBm/100kHz)		Correction factor (100kHz to 3kHz)	Power Density (dBm/3kHz)		Single Port Limit (dBm/3kHz)	Result
	Ant. 1	Ant. 2		Ant. 1	Ant. 2		
2422 MHz	-1.80	-1.70	-15.23	-17.03	-16.93	4.99	Complies
2437 MHz	2.22	2.33	-15.23	-13.01	-12.90	4.99	Complies
2452 MHz	-2.08	-1.89	-15.23	-17.31	-17.12	4.99	Complies

Note: PSD Limit = (8dBm/3kHz - (10log(2)))=4.99dBm/3kHz

**For 5GHz Band**
**Configuration IEEE 802.11n MCS0 20MHz / Ant. 3 + Ant. 4 + Ant. 5 (3TX)**

Frequency	Power Density (dBm/100kHz)			Correction factor (100kHz to 3kHz)	Power Density (dBm/3kHz)			Single Port Limit (dBm/3kHz)	Result
	Ant.3	Ant.4	ANT.5		Ant.3	Ant.4	ANT.5		
5745 MHz	11.87	12.96	13.86	-15.23	-3.36	-2.27	-1.37	3.23	Complies
5785 MHz	11.94	12.49	13.40	-15.23	-3.29	-2.74	-1.83	3.23	Complies
5825 MHz	11.41	12.69	13.67	-15.23	-3.82	-2.54	-1.56	3.23	Complies

Note: Limit = 8dBm/3KHz -(10log(3))=8dBm/3KHz -4.77dB=3.23dBm/3KHz.

**Configuration IEEE 802.11n MCS0 40MHz / Ant. 3 + Ant. 4 + Ant. 5 (3TX)**

Frequency	Power Density (dBm/100kHz)			Correction factor (100kHz to 3kHz)	Power Density (dBm/3kHz)			Single Port Limit (dBm/3kHz)	Result
	Ant.3	Ant.4	ANT.5		Ant.3	Ant.4	ANT.5		
5755 MHz	8.41	9.88	10.41	-15.23	-6.82	-5.35	-4.82	3.23	Complies
5795 MHz	8.59	9.58	10.65	-15.23	-6.64	-5.65	-4.58	3.23	Complies

Note: Limit = 8dBm/3KHz -(10log(3))=8dBm/3KHz -4.77dB=3.23dBm/3KHz.

**Configuration IEEE 802.11ac MCS0 80MHz / Ant. 3 + Ant. 4 + Ant. 5 (3TX)**

Frequency	Power Density (dBm/100kHz)			Correction factor (100kHz to 3kHz)	Power Density (dBm/3kHz)			Single Port Limit (dBm/3kHz)	Result
	Ant.3	Ant.4	ANT.5		Ant.3	Ant.4	ANT.5		
5775 MHz	6.57	7.78	8.13	-15.23	-8.66	-7.45	-7.10	3.23	Complies

Note: Limit = 8dBm/3KHz -(10log(3))=8dBm/3KHz -4.77dB=3.23dBm/3KHz.

Directional gain=GANT+10log(NANT/Nss) =5.56dBi <6dBi, so the limit doesn't reduce.

Temperature	23°C	Humidity	63%
Test Engineer	Benson Peng	Configurations	IEEE 802.11a/b/g

**Configuration IEEE 802.11b / Ant. 2 (1TX)**

Frequency	Power Density (dBm/100kHz)	Correction factor (100kHz to 3kHz)	Power Density (dBm/3kHz)	Single Port Limit (dBm/3kHz)	Result
2412 MHz	10.22	-15.23	-5.01	8.00	Complies
2437 MHz	16.01	-15.23	0.78	8.00	Complies
2462 MHz	11.63	-15.23	-3.60	8.00	Complies

**Configuration IEEE 802.11g / Ant. 1 + Ant. 2 (2TX)**

Frequency	Power Density (dBm/100kHz)		Correction factor (100kHz to 3kHz)	Power Density (dBm/3kHz)		Single Port Limit (dBm/3kHz)	Result
	Ant. 1	Ant. 2		Ant. 1	Ant. 2		
2412 MHz	5.13	4.70	-15.23	-10.10	-10.53	4.99	Complies
2437 MHz	11.02	10.91	-15.23	-4.21	-4.32	4.99	Complies
2462 MHz	3.91	3.80	-15.23	-11.32	-11.43	4.99	Complies

Note: PSD Limit = (8dBm/3kHz - (10log(2)))=4.99dBm/3kHz

**Configuration IEEE 802.11a / Ant. 3 + Ant. 4 + Ant. 5 (3TX)**

Frequency	Power Density (dBm/100kHz)			Correction factor (100kHz to 3kHz)	Power Density (dBm/3kHz)			Single Port Limit (dBm/3kHz)	Result
	Ant.3	Ant.4	ANT.5		Ant.3	Ant.4	ANT.5		
5745 MHz	13.54	13.84	13.90	-15.23	-1.69	-1.39	-1.33	3.23	Complies
5785 MHz	11.92	13.01	13.88	-15.23	-3.31	-2.22	-1.35	3.23	Complies
5825 MHz	11.99	12.67	13.41	-15.23	-3.24	-2.56	-1.82	3.23	Complies

Note: Limit = 8dBm/3KHz - (10log(3))=8dBm/3KHz -4.77dB=3.23dBm/3KHz.

Note: All the test values were listed in the report.

For plots, only the channel with maximum results was shown.

Power Density Plot on Configuration IEEE 802.11n MCS0 20MHz / Ant. 1 / 2437 MHz

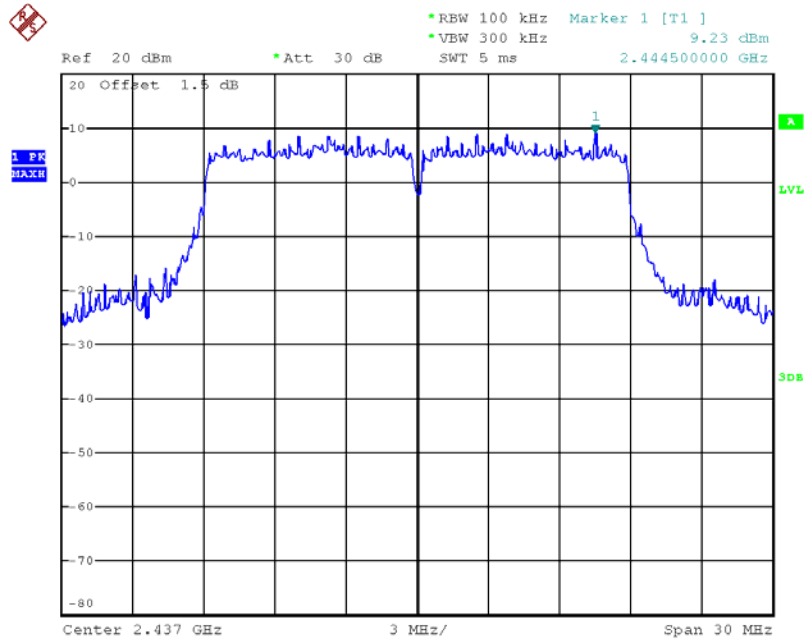

Date: 31.JAN.2013 10:42:10

Power Density Plot on Configuration IEEE 802.11n MCS0 40MHz / Ant. 2 / 2437 MHz

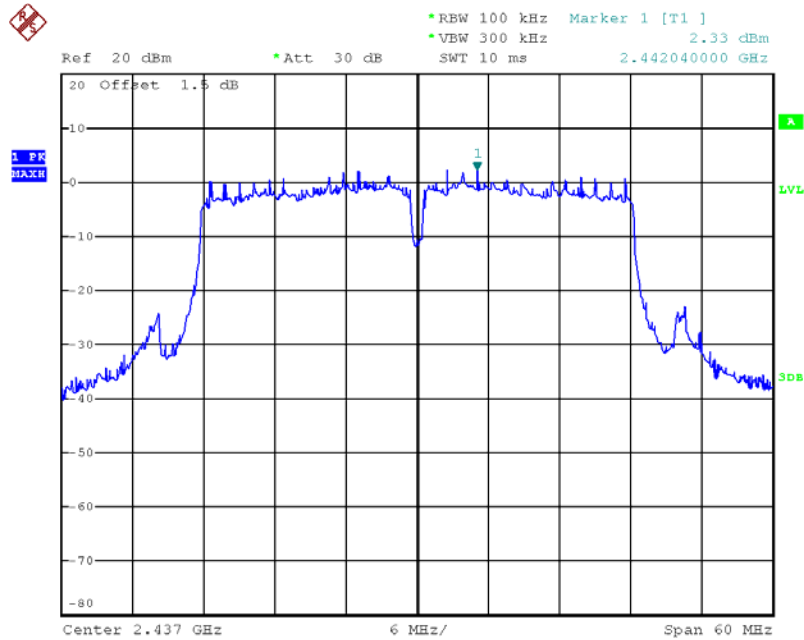

Date: 31.JAN.2013 10:48:25

Power Density Plot on Configuration IEEE 802.11n MCS0 20MHz / Ant. 5 / 5745 MHz

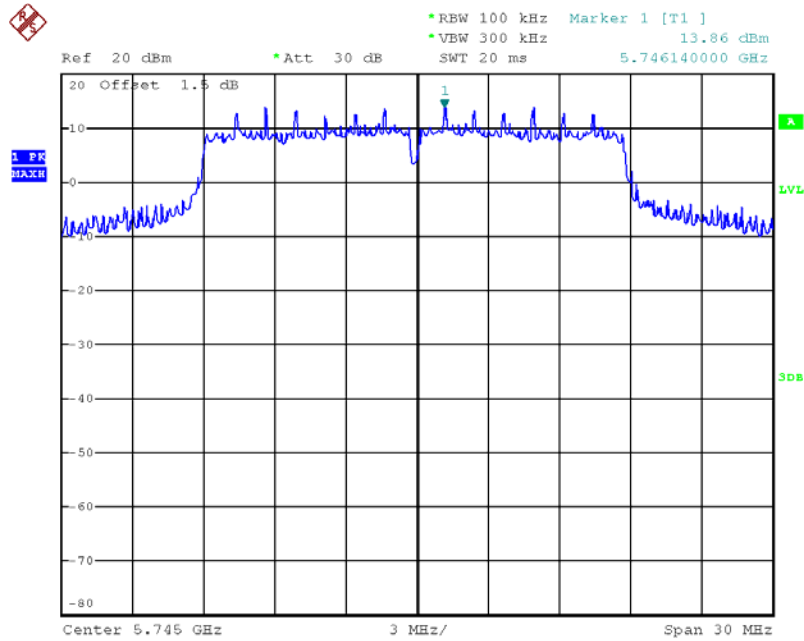

Date: 19.FEB.2013 13:30:43

Power Density Plot on Configuration IEEE 802.11n MCS0 40MHz / Ant. 5 / 5795 MHz

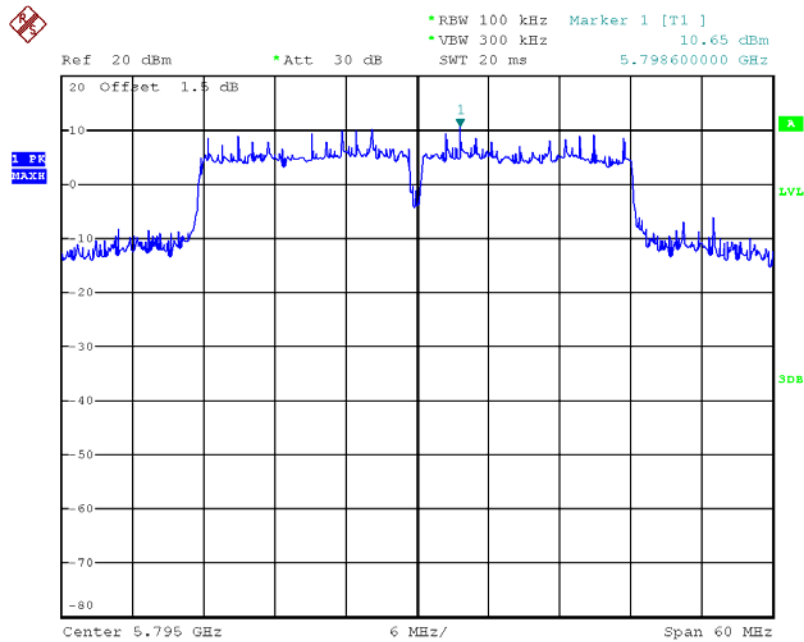

Date: 19.FEB.2013 13:36:39

Power Density Plot on Configuration IEEE 802.11ac MCS0 80MHz / Ant. 5 / 5775 MHz

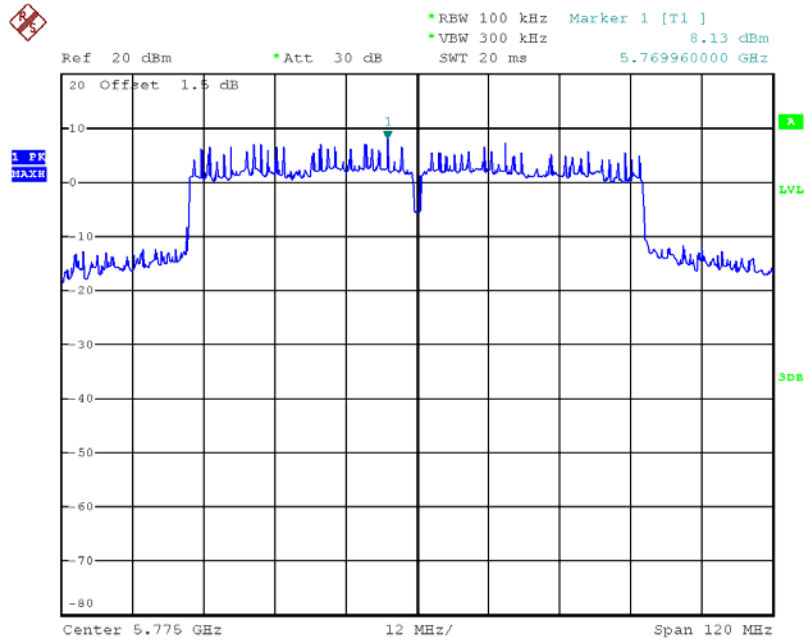

Date: 19.FEB.2013 13:39:32

Power Density Plot on Configuration IEEE 802.11b / Ant. 2 / 2437 MHz

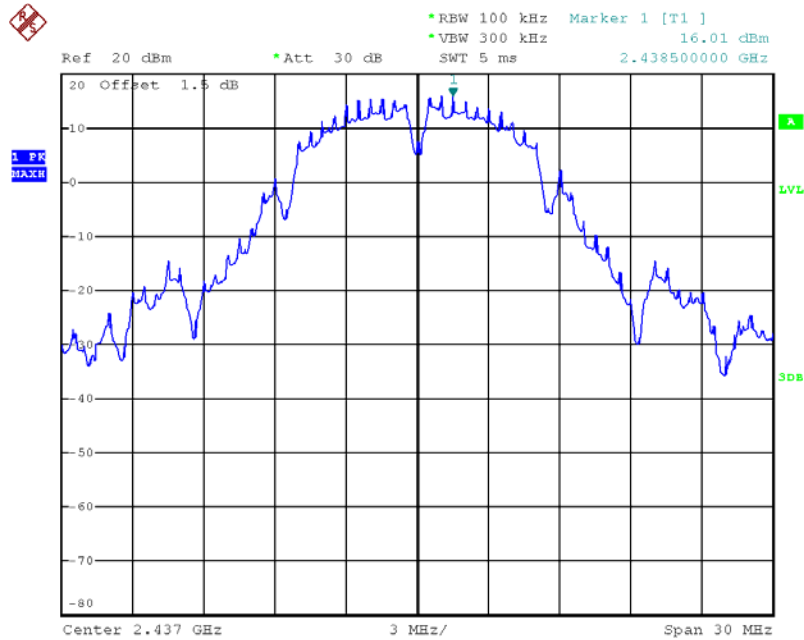

Date: 31.JAN.2013 10:32:03

Power Density Plot on Configuration IEEE 802.11g / Ant. 1 / 2437 MHz

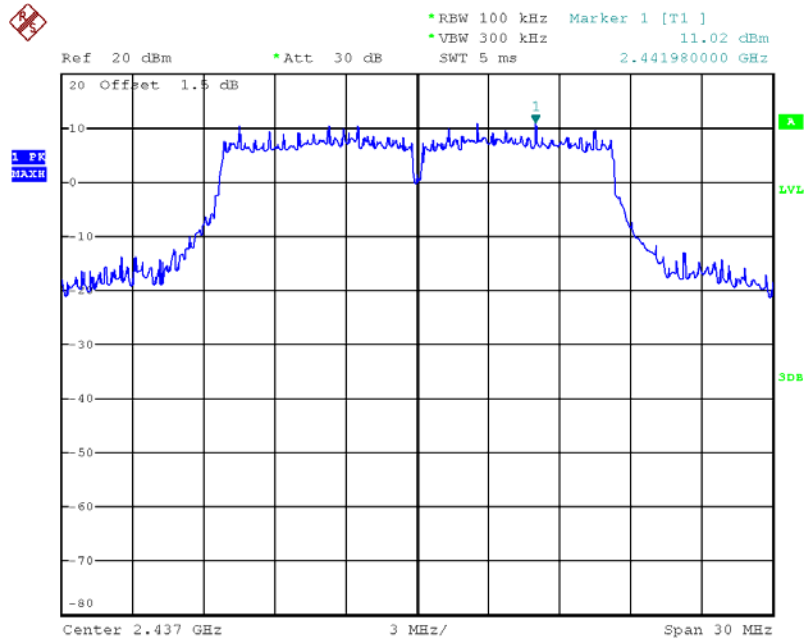

Date: 31.JAN.2013 10:39:01

Power Density Plot on Configuration IEEE 802.11a / Ant. 5 / 5745 MHz

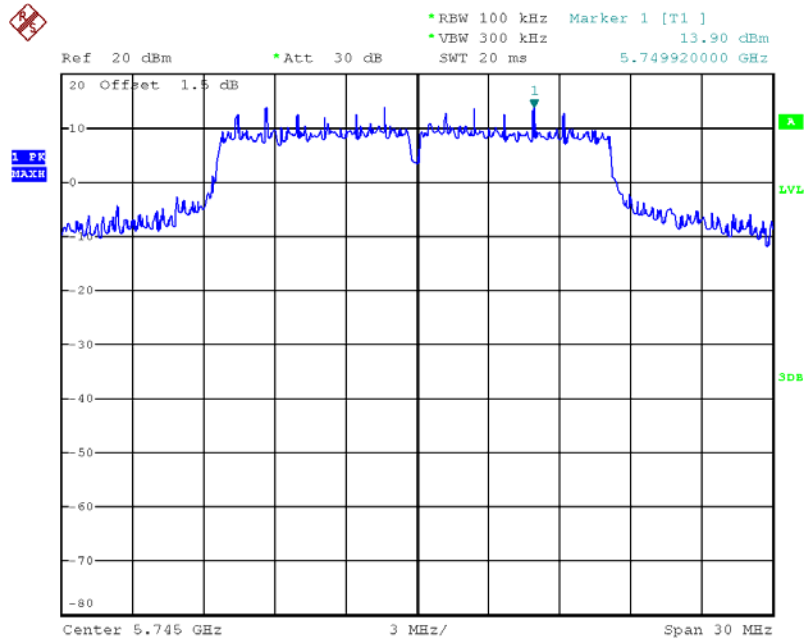

Date: 19.FEB.2013 13:26:17

#### 4.4. 6dB Spectrum Bandwidth Measurement

##### 4.4.1. Limit

For digital modulation systems, the minimum 6dB bandwidth shall be at least 500 kHz.

##### 4.4.2. Measuring Instruments and Setting

Please refer to section 5 of equipments list in this report. The following table is the setting of spectrum analyzer.

Spectrum Parameters	Setting
Attenuation	Auto
Span Frequency	> 6dB Bandwidth
RB	1-5 % or DTS BW, not exceed 100KHz
VB	$\geq 3 \times \text{RBW}$
Detector	Peak
Trace	Max Hold
Sweep Time	Auto

##### 4.4.3. Test Procedures

1. The transmitter output (antenna port) was connected to the spectrum analyzer in peak hold mode.
2. Test was performed in accordance with KDB 558074 Guidance for Performing Compliance Measurements on Digital Transmission Systems (DTS) Operating Under §15.247 section 5.1.1 EBW Measurement Procedure
3. Multiple antenna system was performed in accordance with KDB 662911 Emissions Testing of Transmitters with Multiple Outputs in the Same Band.
4. Measured the spectrum width with power higher than 6dB below carrier.

##### 4.4.4. Test Setup Layout

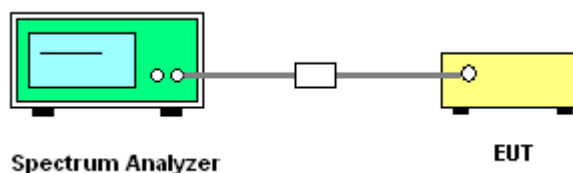

##### 4.4.5. Test Deviation

There is no deviation with the original standard.

##### 4.4.6. EUT Operation during Test

The EUT was programmed to be in continuously transmitting mode.



#### 4.4.7. Test Result of 6dB Spectrum Bandwidth

Temperature	23°C	Humidity	63%
Test Engineer	Benson Peng	Configurations	IEEE 802.11n/ac

For 2.4GHz Band

Configuration IEEE 802.11n MCS0 20MHz / Ant. 1 + Ant. 2 (2TX)

Channel	Frequency	6dB Bandwidth (MHz)	99% Occupied Bandwidth (MHz)	Min. Limit (kHz)	Test Result
1	2412 MHz	16.08	17.44	500	Complies
6	2437 MHz	16.40	17.44	500	Complies
11	2462 MHz	16.00	17.36	500	Complies

Configuration IEEE 802.11n MCS0 40MHz / Ant. 1 + Ant. 2 (2TX)

Channel	Frequency	6dB Bandwidth (MHz)	99% Occupied Bandwidth (MHz)	Min. Limit (kHz)	Test Result
3	2422 MHz	35.20	36.00	500	Complies
6	2437 MHz	35.52	36.16	500	Complies
9	2452 MHz	35.68	36.00	500	Complies

**For 5GHz Band**
**Configuration IEEE 802.11n MCS0 20MHz / Ant. 3 + Ant. 4 + Ant. 5 (3TX)**

Channel	Frequency	6dB Bandwidth (MHz)	99% Occupied Bandwidth (MHz)	Min. Limit (kHz)	Test Result
149	5745 MHz	16.56	24.08	500	Complies
157	5785 MHz	16.72	24.16	500	Complies
165	5825 MHz	16.64	23.84	500	Complies

**Configuration IEEE 802.11n MCS0 40MHz / Ant. 3 + Ant. 4 + Ant. 5 (3TX)**

Channel	Frequency	6dB Bandwidth (MHz)	99% Occupied Bandwidth (MHz)	Min. Limit (kHz)	Test Result
151	5755 MHz	36.00	46.72	500	Complies
159	5795 MHz	36.16	45.92	500	Complies

**Configuration IEEE 802.11ac MCS0 80MHz / Ant. 3 + Ant. 4 + Ant. 5 (3TX)**

Channel	Frequency	6dB Bandwidth (MHz)	99% Occupied Bandwidth (MHz)	Min. Limit (kHz)	Test Result
155	5775 MHz	76.16	88.00	500	Complies

Temperature	23°C	Humidity	63%
Test Engineer	Benson Peng	Configurations	IEEE 802.11a/b/g

**Configuration IEEE 802.11b / Ant. 2 (1TX)**

Channel	Frequency	6dB Bandwidth (MHz)	99% Occupied Bandwidth (MHz)	Min. Limit (kHz)	Test Result
1	2412 MHz	8.08	10.16	500	Complies
6	2437 MHz	8.08	11.36	500	Complies
11	2462 MHz	8.08	10.08	500	Complies

**Configuration IEEE 802.11g / Ant. 1 + Ant. 2 (2TX)**

Channel	Frequency	6dB Bandwidth (MHz)	99% Occupied Bandwidth (MHz)	Min. Limit (kHz)	Test Result
1	2412 MHz	12.64	16.00	500	Complies
6	2437 MHz	12.32	16.08	500	Complies
11	2462 MHz	12.32	15.84	500	Complies

**Configuration IEEE 802.11a / Ant. 3 + Ant. 4 + Ant. 5 (3TX)**

Channel	Frequency	6dB Bandwidth (MHz)	99% Occupied Bandwidth (MHz)	Min. Limit (kHz)	Test Result
149	5745 MHz	16.32	25.04	500	Complies
157	5785 MHz	16.32	24.16	500	Complies
165	5825 MHz	16.24	23.60	500	Complies

Note: All the test values were listed in the report.

For plots, only the channel with maximum results was shown.

6 dB Bandwidth Plot on Configuration IEEE 802.11n MCS0 20MHz / Ant. 1 + Ant. 2 (2TX) / 2462 MHz

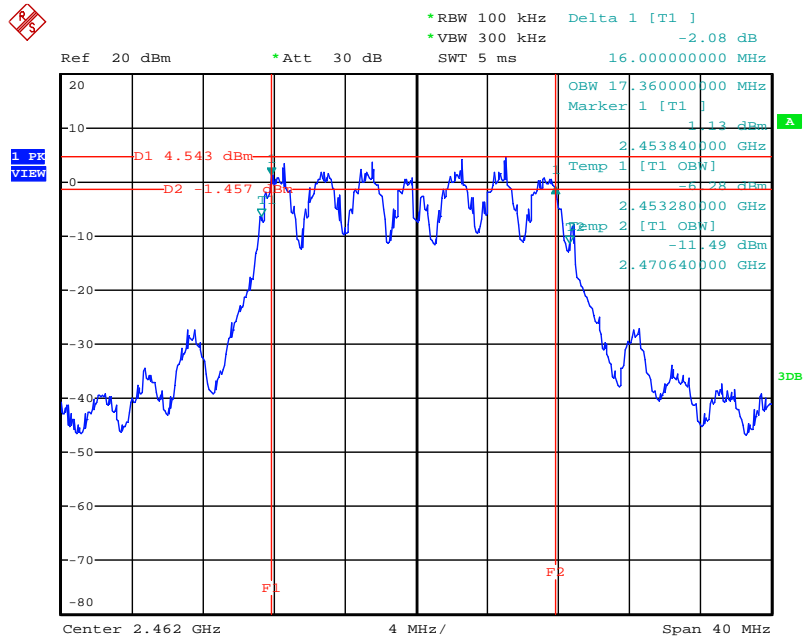

Date: 31.JAN.2013 11:36:43

6 dB Bandwidth Plot on Configuration IEEE 802.11n MCS0 40MHz / Ant. 1 + Ant. 2 (2TX) / 2422 MHz

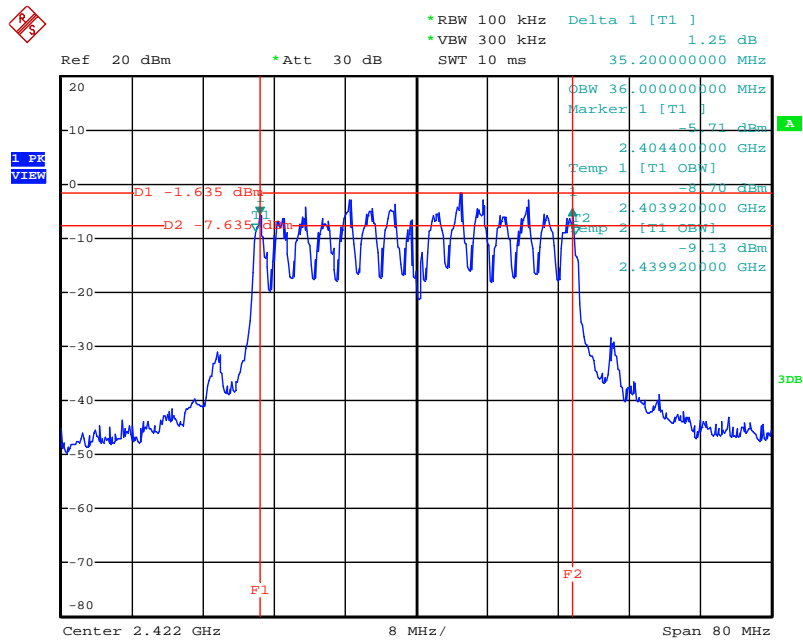

Date: 31.JAN.2013 11:37:22

6 dB Bandwidth Plot on Configuration IEEE 802.11n MCS0 20MHz / Ant. 3 + Ant. 4 + Ant. 5 (3TX)  
/ 5745 MHz

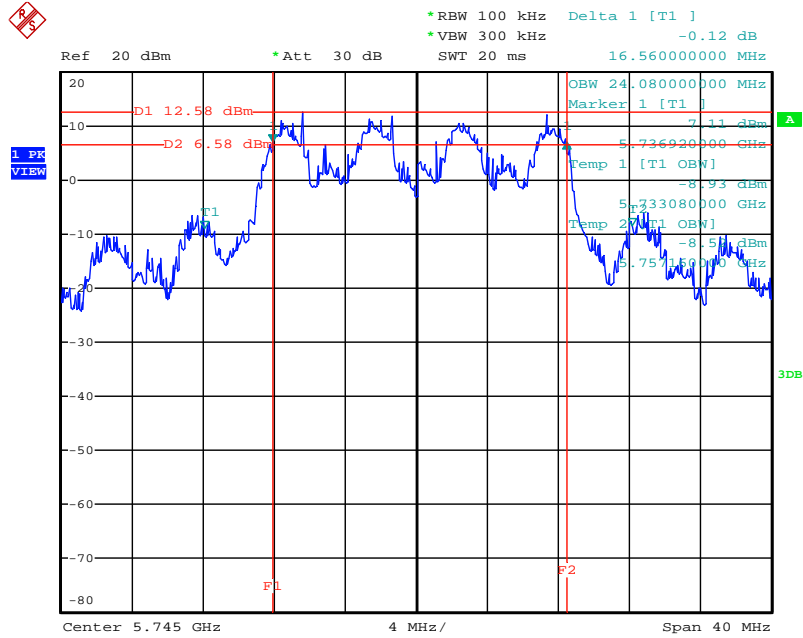

Date: 19.FEB.2013 13:08:27

6 dB Bandwidth Plot on Configuration IEEE 802.11n MCS0 40MHz / Ant. 3 + Ant. 4 + Ant. 5 (3TX)  
/ 5755MHz

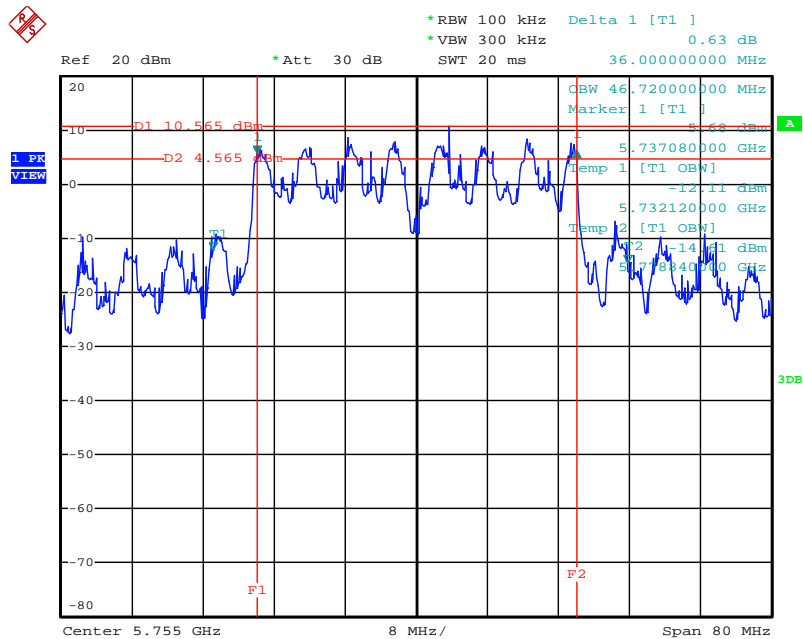

Date: 19.FEB.2013 13:09:06

6 dB Bandwidth Plot on Configuration IEEE 802.11ac MCS0 80MHz / Ant. 3 + Ant. 4 + Ant. 5 (3TX)  
/ 5775 MHz

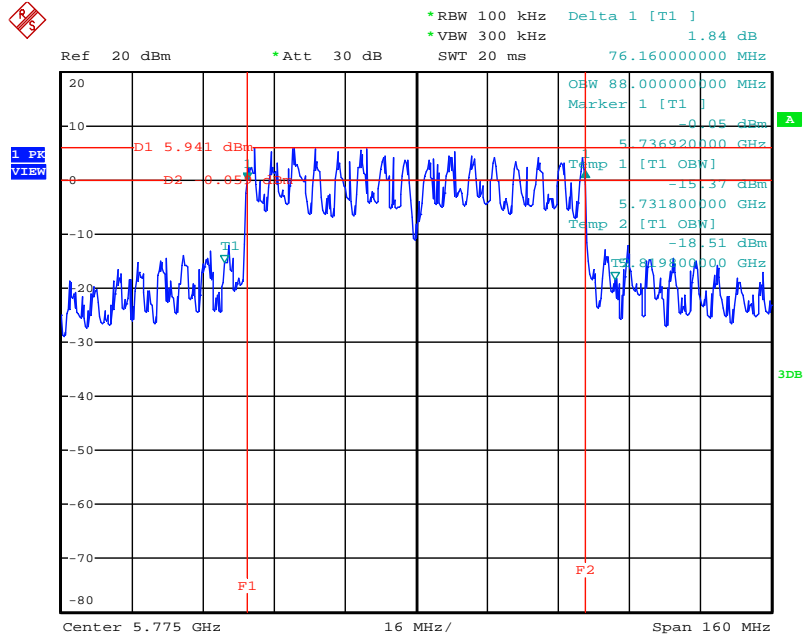

Date: 19.FEB.2013 13:10:41

6 dB Bandwidth Plot on Configuration IEEE 802.11b / Ant. 2 (1TX) / 2437 MHz

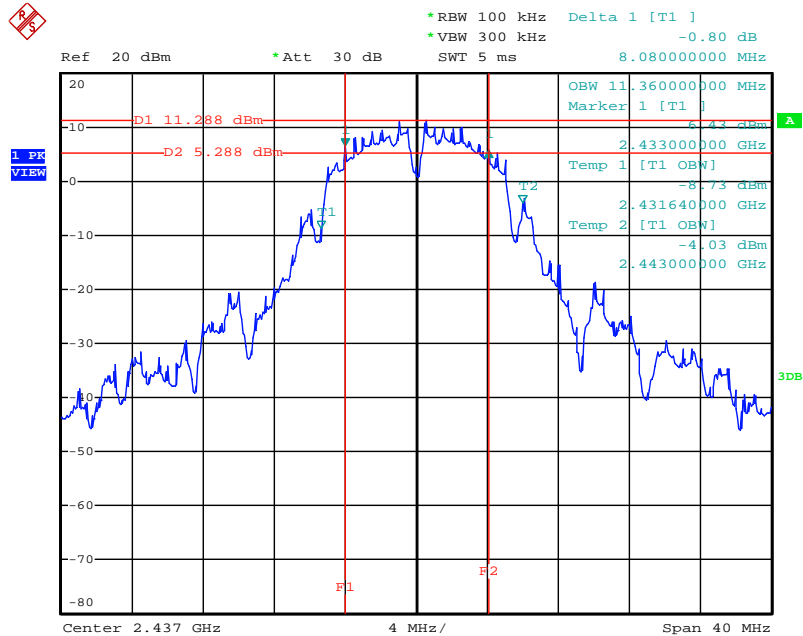

Date: 31.JAN.2013 11:32:43

6 dB Bandwidth Plot on Configuration IEEE 802.11g / Ant. 1 + Ant. 2 (2TX) / 2437 MHz

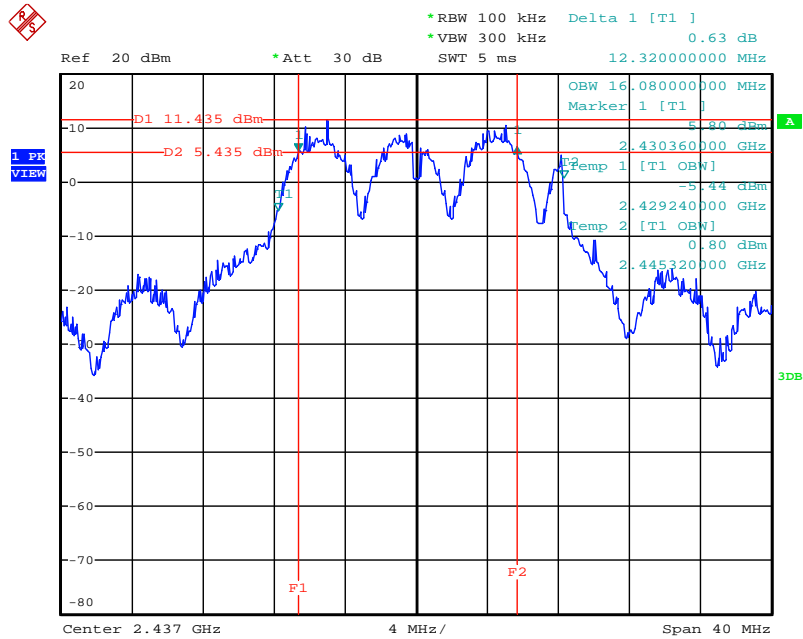

Date: 31.JAN.2013 11:34:57

6 dB Bandwidth Plot on Configuration IEEE 802.11a / Ant. 3 + Ant. 4 + Ant. 5 (3TX) / 5825 MHz

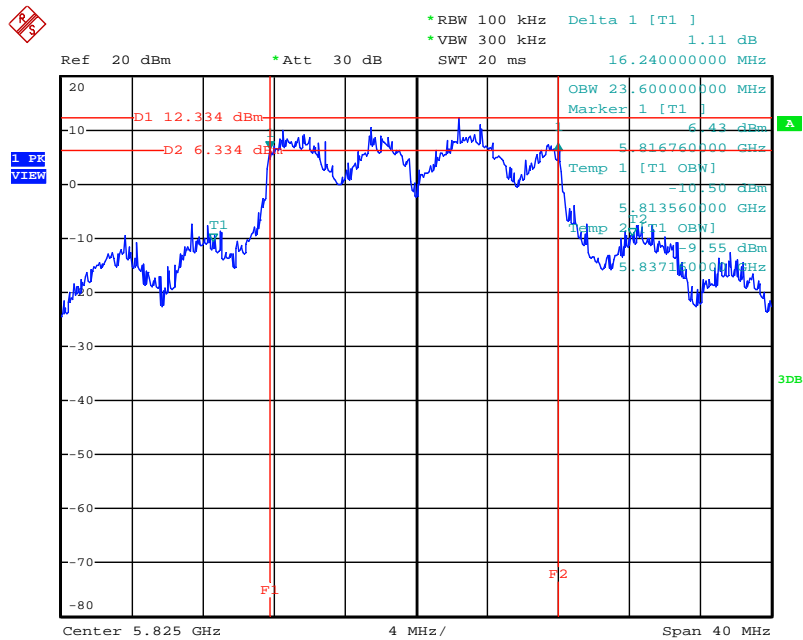

Date: 19.FEB.2013 13:06:40

## 4.5. Radiated Emissions Measurement

### 4.5.1. Limit

30dBc in any 100 kHz bandwidth outside the operating frequency band. In case the emission fall within the restricted band specified on 15.205(a), then the 15.209(a) limit in the table below has to be followed.

Frequencies (MHz)	Field Strength (micorvolts/meter)	Measurement Distance (meters)
0.009~0.490	2400/F(KHz)	300
0.490~1.705	24000/F(KHz)	30
1.705~30.0	30	30
30~88	100	3
88~216	150	3
216~960	200	3
Above 960	500	3

### 4.5.2. Measuring Instruments and Setting

Please refer to section 5 of equipments list in this report. The following table is the setting of spectrum analyzer and receiver.

Spectrum Parameter	Setting
Attenuation	Auto
Start Frequency	1GHz
Stop Frequency	10th carrier harmonic
RB / VB (Emission in restricted band)	1MHz / 3MHz for Peak, 1MHz / 10Hz for Average
RB / VB (Emission in non-restricted band)	100kHz / 300kHz for peak

Receiver Parameter	Setting
Attenuation	Auto
Start ~ Stop Frequency	9kHz~150kHz / RB 200Hz for QP
Start ~ Stop Frequency	150kHz~30MHz / RB 9kHz for QP
Start ~ Stop Frequency	30MHz~1GHz / RB 120kHz for QP



#### 4.5.3. Test Procedures

1. Configure the EUT according to ANSI C63.10. The EUT was placed on the top of the turntable 0.8 meter above ground. The phase center of the receiving antenna mounted on the top of a height-variable antenna tower was placed 3 meters far away from the turntable.
2. Power on the EUT and all the supporting units. The turntable was rotated by 360 degrees to determine the position of the highest radiation.
3. The height of the broadband receiving antenna was varied between one meter and four meters above ground to find the maximum emissions field strength of both horizontal and vertical polarization.
4. For each suspected emissions, the antenna tower was scan (from 1 M to 4 M) and then the turntable was rotated (from 0 degree to 360 degrees) to find the maximum reading.
5. Set the test-receiver system to Peak or CISPR quasi-peak Detect Function with specified bandwidth under Maximum Hold Mode.
6. For emissions above 1GHz, use 1MHz VBW and 3MHz RBW for peak reading. Then 1MHz RBW and 10Hz VBW for average reading in spectrum analyzer.
7. When the radiated emissions limits are expressed in terms of the average value of the emissions, and pulsed operation is employed, the measurement field strength shall be determined by averaging over one complete pulse train, including blanking intervals, as long as the pulse train does not exceed 0.1 seconds. As an alternative (provided the transmitter operates for longer than 0.1 seconds) or in cases where the pulse train exceeds 0.1 seconds, the measured field strength shall be determined from the average absolute voltage during a 0.1 second interval during which the field strength is at its maximum value.
8. If the emissions level of the EUT in peak mode was 3 dB lower than the average limit specified, then testing will be stopped and peak values of EUT will be reported, otherwise, the emissions which do not have 3 dB margin will be repeated one by one using the quasi-peak method for below 1GHz.
9. For testing above 1GHz, the emissions level of the EUT in peak mode was lower than average limit (that means the emissions level in peak mode also complies with the limit in average mode), then testing will be stopped and peak values of EUT will be reported, otherwise, the emissions will be measured in average mode again and reported.
10. In case the emission is lower than 30MHz, loop antenna has to be used for measurement and the recorded data should be QP measured by receiver. High – Low scan is not required in this case.

#### 4.5.4. Test Setup Layout

For radiated emissions below 1GHz

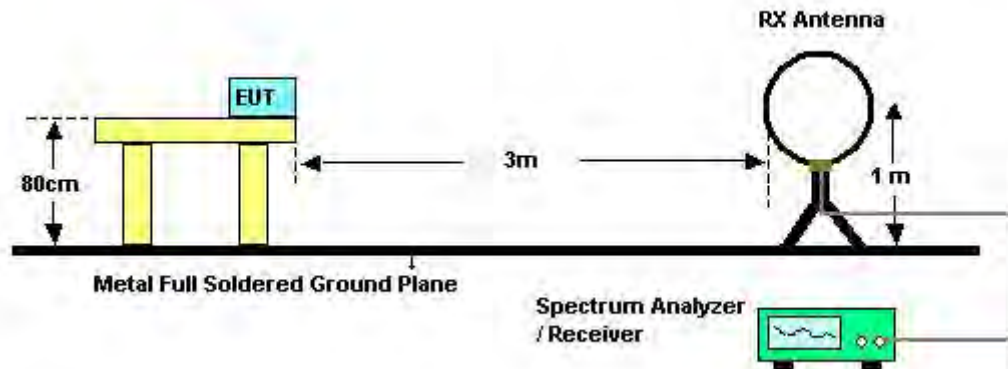

For radiated emissions above 1GHz

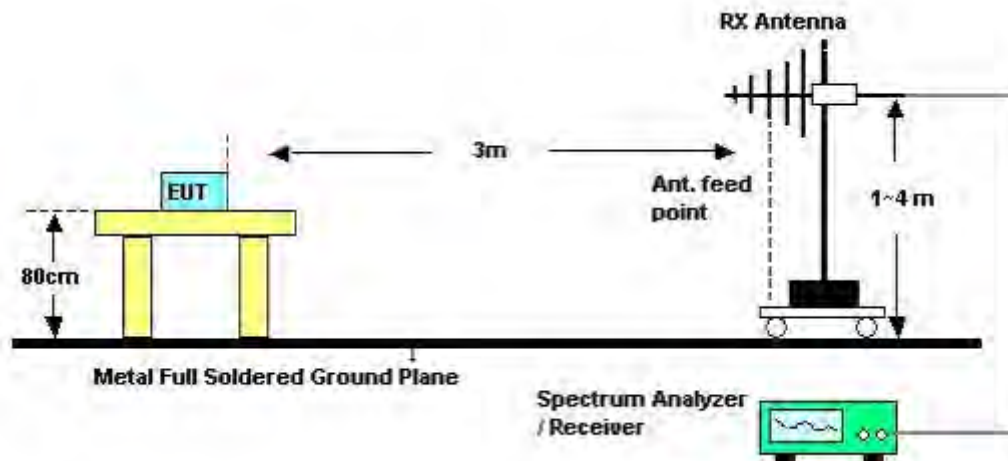

#### 4.5.5. Test Deviation

There is no deviation with the original standard.

#### 4.5.6. EUT Operation during Test

The EUT was programmed to be in continuously transmitting mode.

#### 4.5.7. Results of Radiated Emissions (9kHz~30MHz)

Temperature	21°C	Humidity	56.4%
Test Engineer	Kenneth Huang	Configurations	Normal Link
Test Date	Jan. 23, 2013		

Freq. (MHz)	Level (dBuV)	Over Limit (dB)	Limit Line (dBuV)	Remark
-	-	-	-	See Note

Note:

The amplitude of spurious emissions that are attenuated by more than 20 dB below the permissible value has no need to be reported.

Distance extrapolation factor =  $40 \log (\text{specific distance} / \text{test distance})$  (dB);

Limit line = specific limits (dBuV) + distance extrapolation factor.

4.5.8. Results of Radiated Emissions (30MHz~1GHz)

Temperature	21°C	Humidity	56.4%
Test Engineer	Kenneth Huang	Configurations	Normal Link
Test Mode	Mode 2. EUT + Power Adapter 2		

Horizontal

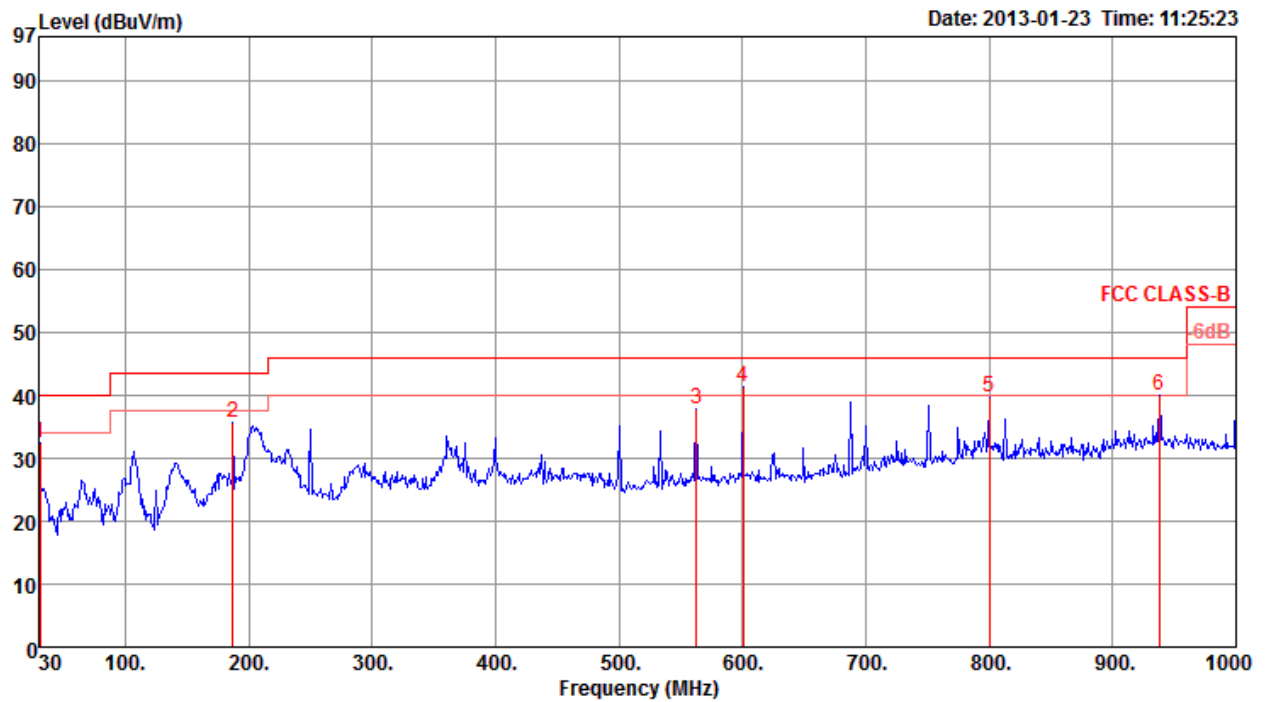

	Freq	Level	Limit	Over	Read	Cable	Preamp	Antenna	Remark	T/Pos	A/Pos	Pol/Phase
	MHz	dBuV/m	dBuV/m	dB	dBuV	Loss	Factor	Factor		deg	cm	
1	30.97	32.47	40.00	-7.53	40.30	0.85	27.98	19.30	Peak	0	400	HORIZONTAL
2	187.14	35.68	43.50	-7.82	51.14	2.04	27.33	9.83	Peak	0	400	HORIZONTAL
3	562.53	37.72	46.00	-8.28	43.02	3.59	27.81	18.92	Peak	0	400	HORIZONTAL
4 p	600.36	41.40	46.00	-4.60	45.97	3.73	27.60	19.30	Peak	0	400	HORIZONTAL
5	800.18	39.76	46.00	-6.24	41.49	4.36	26.89	20.80	Peak	0	400	HORIZONTAL
6	937.92	39.86	46.00	-6.14	39.85	4.79	26.59	21.81	Peak	0	400	HORIZONTAL

Vertical

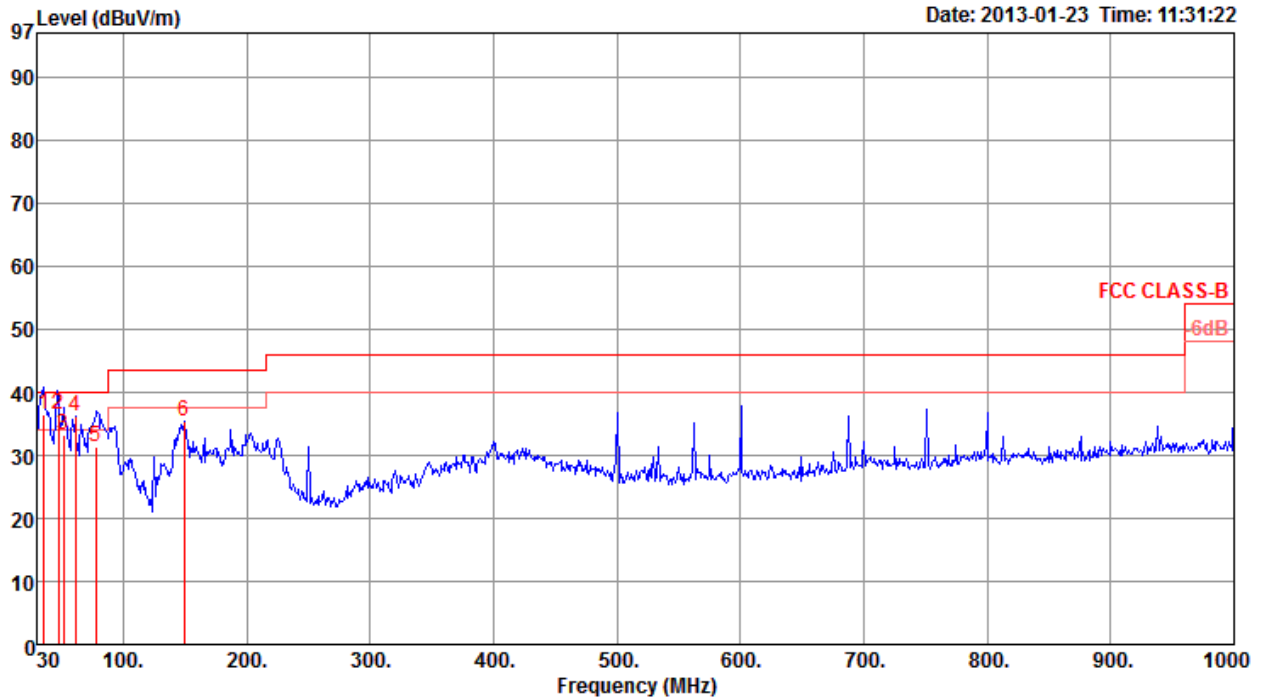

	Freq	Level	Limit	Over	Read	Cable	Preamp	Antenna	Remark	T/Pos	A/Pos	Pol/Phase
	MHz	dBuV/m	dBuV/m	dB	dBuV	dB	dB	dB/m		deg	cm	
1	q	36.13	36.60	-3.40	47.41	0.93	28.00	16.26	QP	101	100	VERTICAL
2	!	47.79	36.44	-3.56	53.60	1.02	27.93	9.75	QP	68	100	VERTICAL
3		51.34	33.18	-6.82	51.51	1.07	27.92	8.52	QP	112	100	VERTICAL
4	p	61.04	36.13	-3.87	56.04	1.18	27.98	6.89	Peak	0	100	VERTICAL
5		77.53	31.22	-8.78	50.50	1.32	27.91	7.31	QP	196	100	VERTICAL
6		149.31	35.48	-8.02	49.92	1.79	27.51	11.28	Peak	0	100	VERTICAL

Note:

The amplitude of spurious emissions that are attenuated by more than 20dB below the permissible value has no need to be reported.

Emission level (dBuV/m) = 20 log Emission level (uV/m).

Corrected Reading: Antenna Factor + Cable Loss + Read Level - Preamp Factor = Level.

4.5.9. Results for Radiated Emissions (1GHz~10<sup>th</sup> Harmonic)

Temperature	25.6	Humidity	56%
Test Engineer	Robert Chang	Configurations	IEEE 802.11n MCS0 20MHz Ch 1 / Ant. 1 + Ant. 2 (2TX)
Test Date	Jan. 22, 2013		

*Horizontal*

	Freq	Level	Limit Line	Over Limit	Read Level	CableAntenna Loss Factor	Preamp Factor	Remark	A/Pos	T/Pos	Pol/Phase
	MHz	dBuV/m	dBuV/m	dB	dBuV	dB	dB/m	dB	cm	deg	
1	4823.30	44.36	74.00	-29.64	43.02	3.31	33.06	35.03	Peak	101	18 HORIZONTAL
2	4823.95	31.30	54.00	-22.70	29.96	3.31	33.06	35.03	Average	101	18 HORIZONTAL

*Vertical*

	Freq	Level	Limit Line	Over Limit	Read Level	CableAntenna Loss Factor	Preamp Factor	Remark	A/Pos	T/Pos	Pol/Phase
	MHz	dBuV/m	dBuV/m	dB	dBuV	dB	dB/m	dB	cm	deg	
1	4823.29	42.45	74.00	-31.55	41.11	3.31	33.06	35.03	Peak	100	281 VERTICAL
2	4823.49	30.22	54.00	-23.78	28.88	3.31	33.06	35.03	Average	100	281 VERTICAL



<b>Temperature</b>	25.6	<b>Humidity</b>	56%
<b>Test Engineer</b>	Robert Chang	<b>Configurations</b>	IEEE 802.11n MCS0 20MHz Ch 6 / Ant. 1 + Ant. 2 (2TX)
<b>Test Date</b>	Jan. 22, 2013		

*Horizontal*

	Freq	Level	Limit Line	Over Limit	Read Level	Cable Loss	Antenna Factor	Preamp Factor	Remark	A/Pos	T/Pos	Pol/Phase
	MHz	dBuV/m	dBuV/m	dB	dBuV	dB	dB/m	dB		cm	deg	
1	4873.82	34.54	54.00	-19.46	33.08	3.33	33.16	35.03	Average	100	105	HORIZONTAL
2	4875.88	46.67	74.00	-27.33	45.21	3.33	33.16	35.03	Peak	100	105	HORIZONTAL
3	7310.18	53.51	74.00	-20.49	48.89	4.06	35.96	35.40	Peak	128	277	HORIZONTAL
4	7310.67	38.66	54.00	-15.34	34.04	4.06	35.96	35.40	Average	128	277	HORIZONTAL

*Vertical*

	Freq	Level	Limit Line	Over Limit	Read Level	Cable Loss	Antenna Factor	Preamp Factor	Remark	A/Pos	T/Pos	Pol/Phase
	MHz	dBuV/m	dBuV/m	dB	dBuV	dB	dB/m	dB		cm	deg	
1	4873.10	37.60	54.00	-16.40	36.14	3.33	33.16	35.03	Average	100	102	VERTICAL
2	4873.11	55.05	74.00	-18.95	53.59	3.33	33.16	35.03	Peak	100	102	VERTICAL
3	7312.55	56.31	74.00	-17.69	51.69	4.06	35.96	35.40	Peak	100	344	VERTICAL
4	7312.92	40.58	54.00	-13.42	35.96	4.06	35.96	35.40	Average	100	344	VERTICAL



<b>Temperature</b>	25.6	<b>Humidity</b>	56%
<b>Test Engineer</b>	Robert Chang	<b>Configurations</b>	IEEE 802.11n MCS0 20MHz Ch 11 / Ant. 1 + Ant. 2 (2TX)
<b>Test Date</b>	Jan. 22, 2013		

*Horizontal*

	Freq	Level	Limit Line	Over Limit	Read Level	Cable Loss	Antenna Factor	Preamp Factor	Remark	A/Pos	T/Pos	Pol/Phase
	MHz	dBuV/m	dBuV/m	dB	dBuV	dB	dB/m	dB		cm	deg	
1	4923.99	32.63	54.00	-21.37	31.03	3.35	33.26	35.01	Average	100	238	HORIZONTAL
2	4923.99	45.00	74.00	-29.00	43.40	3.35	33.26	35.01	Peak	100	238	HORIZONTAL
3	7387.39	46.55	74.00	-27.45	41.80	4.06	36.09	35.40	Peak	100	159	HORIZONTAL
4	7387.88	35.16	54.00	-18.84	30.41	4.06	36.09	35.40	Average	100	159	HORIZONTAL

*Vertical*

	Freq	Level	Limit Line	Over Limit	Read Level	Cable Loss	Antenna Factor	Preamp Factor	Remark	A/Pos	T/Pos	Pol/Phase
	MHz	dBuV/m	dBuV/m	dB	dBuV	dB	dB/m	dB		cm	deg	
1	4924.70	31.97	54.00	-22.03	30.37	3.35	33.26	35.01	Average	100	11	VERTICAL
2	4926.49	43.97	74.00	-30.03	42.37	3.35	33.26	35.01	Peak	100	11	VERTICAL
3	7385.83	35.31	54.00	-18.69	30.56	4.06	36.09	35.40	Average	100	213	VERTICAL
4	7387.25	46.28	74.00	-27.72	41.53	4.06	36.09	35.40	Peak	100	213	VERTICAL



Temperature	25.6	Humidity	56%
Test Engineer	Robert Chang	Configurations	IEEE 802.11n MCS0 40MHz Ch 3 / Ant. 1 + Ant. 2 (2TX)
Test Date	Jan. 22, 2013		

### Horizontal

	Freq	Level	Limit Line	Over Limit	Read Level	Cable Loss	Antenna Factor	Preamp Factor	Remark	A/Pos	T/Pos	Pol/Phase
	MHz	dBuV/m	dBuV/m	dB	dBuV	dB	dB/m	dB		cm	deg	
1	4842.31	42.78	74.00	-31.22	41.40	3.32	33.09	35.03	Peak	100	295	HORIZONTAL
2	4844.10	30.02	54.00	-23.98	28.64	3.32	33.09	35.03	Average	100	295	HORIZONTAL

### Vertical

	Freq	Level	Limit Line	Over Limit	Read Level	Cable Loss	Antenna Factor	Preamp Factor	Remark	A/Pos	T/Pos	Pol/Phase
	MHz	dBuV/m	dBuV/m	dB	dBuV	dB	dB/m	dB		cm	deg	
1	4844.10	43.01	74.00	-30.99	41.63	3.32	33.09	35.03	Peak	100	155	VERTICAL
2	4844.31	29.80	54.00	-24.20	28.42	3.32	33.09	35.03	Average	100	155	VERTICAL

<b>Temperature</b>	25.6	<b>Humidity</b>	56%
<b>Test Engineer</b>	Robert Chang	<b>Configurations</b>	IEEE 802.11n MCS0 40MHz Ch 6 / Ant. 1 + Ant. 2 (2TX)
<b>Test Date</b>	Jan. 22, 2013		

### Horizontal

	Freq	Level	Limit	Over	Read	Cable	Antenna	Preamp	Remark	A/Pos	T/Pos	Pol/Phase
	MHz	dBuV/m	dBuV/m	dB	dBuV	dB	dB/m	dB		cm	deg	
1	4874.02	30.77	54.00	-23.23	29.31	3.33	33.16	35.03	Average	100	225	HORIZONTAL
2	4874.41	43.98	74.00	-30.02	42.52	3.33	33.16	35.03	Peak	100	225	HORIZONTAL

### Vertical

	Freq	Level	Limit	Over	Read	Cable	Antenna	Preamp	Remark	A/Pos	T/Pos	Pol/Phase
	MHz	dBuV/m	dBuV/m	dB	dBuV	dB	dB/m	dB		cm	deg	
1	4874.82	43.57	74.00	-30.43	42.11	3.33	33.16	35.03	Peak	100	292	VERTICAL
2	4874.84	30.51	54.00	-23.49	29.05	3.33	33.16	35.03	Average	100	292	VERTICAL



<b>Temperature</b>	25.6	<b>Humidity</b>	56%
<b>Test Engineer</b>	Robert Chang	<b>Configurations</b>	IEEE 802.11n MCS0 40MHz Ch 9 / Ant. 1 + Ant. 2 (2TX)
<b>Test Date</b>	Jan. 22, 2013		

*Horizontal*

	Freq	Level	Limit Line	Over Limit	Read Level	Cable Loss	Antenna Factor	Preamp Factor	Remark	A/Pos	T/Pos	PoI/Phase
	MHz	dBuV/m	dBuV/m	dB	dBuV	dB	dB/m	dB		cm	deg	
1	4903.06	42.70	74.00	-31.30	41.19	3.34	33.19	35.02	Peak	100	128	HORIZONTAL
2	4903.95	30.29	54.00	-23.71	28.78	3.34	33.19	35.02	Average	100	128	HORIZONTAL

*Vertical*

	Freq	Level	Limit Line	Over Limit	Read Level	Cable Loss	Antenna Factor	Preamp Factor	Remark	A/Pos	T/Pos	PoI/Phase
	MHz	dBuV/m	dBuV/m	dB	dBuV	dB	dB/m	dB		cm	deg	
1	4901.57	43.01	74.00	-30.99	41.50	3.34	33.19	35.02	Peak	100	232	VERTICAL
2	4903.74	30.46	54.00	-23.54	28.95	3.34	33.19	35.02	Average	100	232	VERTICAL



<b>Temperature</b>	25.6	<b>Humidity</b>	56%
<b>Test Engineer</b>	Robert Chang	<b>Configurations</b>	IEEE 802.11n MCS0 20MHz Ch 149 / Ant. 3 + Ant. 4 + Ant. 5 (3TX)
<b>Test Date</b>	Jan. 22, 2013		

*Horizontal*

	Freq	Level	Limit	Over	Read	CableAntenna	Preamp	Remark	A/Pos	T/Pos	Pol/Phase
	MHz	dBuV/m	dBuV/m	dB	dBuV	dB	dB/m	dB	cm	deg	
1	3829.92	54.39	74.00	-19.61	55.08	2.84	31.64	35.17	142	125	HORIZONTAL
2	3829.98	50.85	54.00	-3.15	51.54	2.84	31.64	35.17	142	125	HORIZONTAL
3	11488.20	41.16	54.00	-12.84	32.55	5.11	38.78	35.28	112	91	HORIZONTAL
4	11488.20	53.29	74.00	-20.71	44.68	5.11	38.78	35.28	112	91	HORIZONTAL

*Vertical*

	Freq	Level	Limit	Over	Read	CableAntenna	Preamp	Remark	A/Pos	T/Pos	Pol/Phase
	MHz	dBuV/m	dBuV/m	dB	dBuV	dB	dB/m	dB	cm	deg	
1	3829.92	50.37	74.00	-23.63	51.06	2.84	31.64	35.17	118	132	VERTICAL
2	3829.99	48.16	54.00	-5.84	48.85	2.84	31.64	35.17	118	132	VERTICAL
3	11488.10	54.91	74.00	-19.09	46.30	5.11	38.78	35.28	105	92	VERTICAL
4	11488.40	42.31	54.00	-11.69	33.70	5.11	38.78	35.28	105	92	VERTICAL

Temperature	25.6	Humidity	56%
Test Engineer	Robert Chang	Configurations	IEEE 802.11n MCS0 20MHz Ch 157 / Ant. 3 + Ant. 4 + Ant. 5 (3TX)
Test Date	Jan. 22, 2013		

### Horizontal

	Freq	Level	Limit	Over	Read	Cable	Antenna	Preamp	Remark	A/Pos	T/Pos	Pol/Phase
	MHz	dBuV/m	dBuV/m	dB	dBuV	dB	dB/m	dB		cm	deg	
1	3856.61	54.63	74.00	-19.37	55.14	2.84	31.81	35.16	Peak	157	119	HORIZONTAL
2	3856.64	50.95	54.00	-3.05	51.46	2.84	31.81	35.16	Average	157	119	HORIZONTAL
3	11560.90	53.32	74.00	-20.68	44.67	5.13	38.82	35.30	Peak	110	110	HORIZONTAL
4	11570.30	40.80	54.00	-13.20	32.13	5.14	38.83	35.30	Average	110	110	HORIZONTAL

### Vertical

	Freq	Level	Limit	Over	Read	Cable	Antenna	Preamp	Remark	A/Pos	T/Pos	Pol/Phase
	MHz	dBuV/m	dBuV/m	dB	dBuV	dB	dB/m	dB		cm	deg	
1	3856.65	52.84	74.00	-21.16	53.35	2.84	31.81	35.16	Peak	119	86	VERTICAL
2	3856.66	47.98	54.00	-6.02	48.49	2.84	31.81	35.16	Average	119	86	VERTICAL
3	11566.00	53.22	74.00	-20.78	44.57	5.13	38.82	35.30	Peak	100	217	VERTICAL
4	11567.80	39.68	54.00	-14.32	31.02	5.13	38.83	35.30	Average	100	217	VERTICAL



<b>Temperature</b>	25.6	<b>Humidity</b>	56%
<b>Test Engineer</b>	Robert Chang	<b>Configurations</b>	IEEE 802.11n MCS0 20MHz Ch 165 / Ant. 3 + Ant. 4 + Ant. 5 (3TX)
<b>Test Date</b>	Jan. 22, 2013		

*Horizontal*

	Freq	Level	Limit	Over	Read	CableAntenna	Preamp	Remark	A/Pos	T/Pos	PoI/Phase
	MHz	dBuV/m	dBuV/m	dB	dBuV	dB	dB/m	dB	cm	deg	
1	3883.27	52.47	74.00	-21.53	52.80	2.84	31.98	35.15	144	136	HORIZONTAL
2	3883.31	50.11	54.00	-3.89	50.44	2.84	31.98	35.15	144	136	HORIZONTAL
3	11649.70	40.55	54.00	-13.45	31.83	5.16	38.86	35.30	108	90	HORIZONTAL
4	11655.00	52.62	74.00	-21.38	43.90	5.16	38.86	35.30	108	90	HORIZONTAL

*Vertical*

	Freq	Level	Limit	Over	Read	CableAntenna	Preamp	Remark	A/Pos	T/Pos	PoI/Phase
	MHz	dBuV/m	dBuV/m	dB	dBuV	dB	dB/m	dB	cm	deg	
1	3883.32	48.02	54.00	-5.98	48.35	2.84	31.98	35.15	116	100	VERTICAL
2	3883.34	51.70	74.00	-22.30	52.03	2.84	31.98	35.15	116	100	VERTICAL
3	11648.40	43.47	54.00	-10.53	34.75	5.16	38.86	35.30	116	298	VERTICAL
4	11657.20	54.38	74.00	-19.62	45.66	5.16	38.86	35.30	116	298	VERTICAL



<b>Temperature</b>	25.6	<b>Humidity</b>	56%
<b>Test Engineer</b>	Robert Chang	<b>Configurations</b>	IEEE 802.11n MCS0 40MHz Ch 151 / Ant. 3 + Ant. 4 + Ant. 5 (3TX)
<b>Test Date</b>	Jan. 22, 2013		

*Horizontal*

	Freq	Level	Limit	Over	Read	CableAntenna	Preamp	Remark	A/Pos	T/Pos	Pol/Phase
	MHz	dBuV/m	dBuV/m	dB	dBuV	dB	dB/m	dB	cm	deg	
1	3836.58	54.40	74.00	-19.60	55.01	2.84	31.72	35.17	Peak	143	127 HORIZONTAL
2	3836.66	50.64	54.00	-3.36	51.25	2.84	31.72	35.17	Average	143	127 HORIZONTAL
3	11496.80	39.36	54.00	-14.64	30.74	5.12	38.78	35.28	Average	100	201 HORIZONTAL
4	11504.90	52.26	74.00	-21.74	43.63	5.12	38.79	35.28	Peak	100	201 HORIZONTAL

*Vertical*

	Freq	Level	Limit	Over	Read	CableAntenna	Preamp	Remark	A/Pos	T/Pos	Pol/Phase
	MHz	dBuV/m	dBuV/m	dB	dBuV	dB	dB/m	dB	cm	deg	
1	3836.68	47.64	54.00	-6.36	48.25	2.84	31.72	35.17	Average	117	128 VERTICAL
2	3836.76	51.22	74.00	-22.78	51.83	2.84	31.72	35.17	Peak	117	128 VERTICAL
3	11502.60	40.22	54.00	-13.78	31.59	5.12	38.79	35.28	Average	117	156 VERTICAL
4	11511.20	52.90	74.00	-21.10	44.27	5.12	38.79	35.28	Peak	117	156 VERTICAL



<b>Temperature</b>	25.6	<b>Humidity</b>	56%
<b>Test Engineer</b>	Robert Chang	<b>Configurations</b>	IEEE 802.11n MCS0 40MHz Ch 159 / Ant. 3 + Ant. 4 + Ant. 5 (3TX)
<b>Test Date</b>	Jan. 22, 2013		

*Horizontal*

	Freq	Level	Limit Line	Over Limit	Read Level	Cable Loss	Antenna Factor	Preamp Factor	Remark	A/Pos	T/Pos	Pol/Phase
	MHz	dBuV/m	dBuV/m	dB	dBuV	dB	dB/m	dB		cm	deg	
1	3863.29	54.85	74.00	-19.15	55.36	2.84	31.81	35.16	Peak	161	104	HORIZONTAL
2	3863.31	51.07	54.00	-2.93	51.58	2.84	31.81	35.16	Average	161	104	HORIZONTAL
3	11588.10	53.35	74.00	-20.65	44.68	5.14	38.83	35.30	Peak	100	101	HORIZONTAL
4	11589.90	41.13	54.00	-12.87	32.46	5.14	38.83	35.30	Average	100	101	HORIZONTAL

*Vertical*

	Freq	Level	Limit Line	Over Limit	Read Level	Cable Loss	Antenna Factor	Preamp Factor	Remark	A/Pos	T/Pos	Pol/Phase
	MHz	dBuV/m	dBuV/m	dB	dBuV	dB	dB/m	dB		cm	deg	
1	3863.31	47.36	54.00	-6.64	47.87	2.84	31.81	35.16	Average	136	133	VERTICAL
2	3863.35	52.35	74.00	-21.65	52.86	2.84	31.81	35.16	Peak	136	133	VERTICAL
3	11592.80	50.69	74.00	-23.31	42.02	5.14	38.83	35.30	Peak	112	14	VERTICAL
4	11597.10	38.88	54.00	-15.12	30.20	5.15	38.83	35.30	Average	112	14	VERTICAL





Temperature	24.5	Humidity	60%
Test Engineer	Serway Li	Configurations	IEEE 802.11ac MCS0 20MHz Ch 149 / Ant. 3 + Ant. 4 + Ant. 5 (3TX)
Test Date	Feb. 19, 2013		

*Horizontal*

	Freq	Level	Limit Line	Over Limit	Read Level	Cable Loss	Antenna Factor	Preamp Factor	A/Pos	T/Pos	Pol/Phase	Remark
	MHz	dBuV/m	dBuV/m	dB	dBuV	dB	dB/m	dB	cm	deg		
1 pk	11484.56	66.82	74.00	-7.18	53.48	9.09	39.10	34.85	100	337	HORIZONTAL	Peak
2 pp	11491.08	51.14	54.00	-2.86	37.80	9.09	39.10	34.85	100	337	HORIZONTAL	Average

*Vertical*

	Freq	Level	Limit Line	Over Limit	Read Level	Cable Loss	Antenna Factor	Preamp Factor	A/Pos	T/Pos	Pol/Phase	Remark
	MHz	dBuV/m	dBuV/m	dB	dBuV	dB	dB/m	dB	cm	deg		
1 pk	11483.04	58.84	74.00	-15.16	45.50	9.09	39.10	34.85	100	135	VERTICAL	Peak
2 pp	11492.84	47.29	54.00	-6.71	33.95	9.09	39.10	34.85	100	135	VERTICAL	Average



Temperature	24.5	Humidity	60%
Test Engineer	Serway Li	Configurations	IEEE 802.11ac MCS0 20MHz Ch 157 / Ant. 3 + Ant. 4 + Ant. 5 (3TX)
Test Date	Feb. 19, 2013		

*Horizontal*

	Freq	Level	Limit Line	Over Limit	Read Level	Cable Loss	Antenna Factor	Preamp Factor	A/Pos	T/Pos	Pol/Phase	Remark
	MHz	dBuV/m	dBuV/m	dB	dBuV	dB	dB/m	dB	cm	deg		
1 pk	11564.56	66.19	74.00	-7.81	52.92	9.11	39.01	34.85	100	336	HORIZONTAL	Peak
2 pp	11571.16	50.57	54.00	-3.43	37.30	9.11	39.01	34.85	100	336	HORIZONTAL	Average

*Vertical*

	Freq	Level	Limit Line	Over Limit	Read Level	Cable Loss	Antenna Factor	Preamp Factor	A/Pos	T/Pos	Pol/Phase	Remark
	MHz	dBuV/m	dBuV/m	dB	dBuV	dB	dB/m	dB	cm	deg		
1 pk	11567.72	59.26	74.00	-14.74	45.99	9.11	39.01	34.85	100	134	VERTICAL	Peak
2 pp	11567.84	47.60	54.00	-6.40	34.33	9.11	39.01	34.85	100	134	VERTICAL	Average



<b>Temperature</b>	24.5	<b>Humidity</b>	60%
<b>Test Engineer</b>	Serway Li	<b>Configurations</b>	IEEE 802.11ac MCS0 20MHz Ch 165 / Ant. 3 + Ant. 4 + Ant. 5 (3TX)
<b>Test Date</b>	Feb. 19, 2013		

*Horizontal*

	Freq	Level	Limit Line	Over Limit	Read Level	Cable Loss	Antenna Factor	Preamp Factor	A/Pos	T/Pos	Pol/Phase	Remark
	MHz	dBuV/m	dBuV/m	dB	dBuV	dB	dB/m	dB	cm	deg		
1 pp	11648.80	50.90	54.00	-3.10	37.71	9.11	38.93	34.85	100	336	HORIZONTAL	Average
2 pk	11653.92	61.34	74.00	-12.66	48.19	9.11	38.89	34.85	100	336	HORIZONTAL	Peak

*Vertical*

	Freq	Level	Limit Line	Over Limit	Read Level	Cable Loss	Antenna Factor	Preamp Factor	A/Pos	T/Pos	Pol/Phase	Remark
	MHz	dBuV/m	dBuV/m	dB	dBuV	dB	dB/m	dB	cm	deg		
1 pp	11650.08	47.56	54.00	-6.44	34.37	9.11	38.93	34.85	106	43	VERTICAL	Average
2 pk	11650.12	59.63	74.00	-14.37	46.44	9.11	38.93	34.85	106	43	VERTICAL	Peak

Temperature	24.5	Humidity	60%
Test Engineer	Serway Li	Configurations	IEEE 802.11ac MCS0 40MHz Ch 151 / Ant. 3 + Ant. 4 + Ant. 5 (3TX)
Test Date	Feb. 19, 2013		

### Horizontal

	Freq	Level	Limit Line	Over Limit	Read Level	CableAntenna Loss	Antenna Factor	Preamp Factor	A/Pos	T/Pos	Pol/Phase	Remark
	MHz	dBuV/m	dBuV/m	dB	dBuV	dB	dB/m	dB	cm	deg		
1 pp	11506.20	51.22	54.00	-2.78	37.87	9.10	39.10	34.85	100	337	HORIZONTAL	Average
2 pk	11506.36	65.33	74.00	-8.67	51.98	9.10	39.10	34.85	100	337	HORIZONTAL	Peak

### Vertical

	Freq	Level	Limit Line	Over Limit	Read Level	CableAntenna Loss	Antenna Factor	Preamp Factor	A/Pos	T/Pos	Pol/Phase	Remark
	MHz	dBuV/m	dBuV/m	dB	dBuV	dB	dB/m	dB	cm	deg		
1 pp	11507.92	46.46	54.00	-7.54	33.11	9.10	39.10	34.85	100	135	VERTICAL	Average
2 pk	11512.84	58.77	74.00	-15.23	45.42	9.10	39.10	34.85	100	135	VERTICAL	Peak



<b>Temperature</b>	24.5	<b>Humidity</b>	60%
<b>Test Engineer</b>	Serway Li	<b>Configurations</b>	IEEE 802.11ac MCS0 40MHz Ch 159 / Ant. 3 + Ant. 4 + Ant. 5 (3TX)
<b>Test Date</b>	Feb. 19, 2013		

*Horizontal*

	Freq	Level	Limit Line	Over Limit	Read Level	Cable Loss	Antenna Factor	Preamp Factor	A/Pos	T/Pos	Pol/Phase	Remark
	MHz	dBuV/m	dBuV/m	dB	dBuV	dB	dB/m	dB	cm	deg		
1 pp	11583.64	50.59	54.00	-3.41	37.36	9.11	38.97	34.85	100	337	HORIZONTAL	Average
2 pk	11595.00	64.65	74.00	-9.35	51.42	9.11	38.97	34.85	100	337	HORIZONTAL	Peak

*Vertical*

	Freq	Level	Limit Line	Over Limit	Read Level	Cable Loss	Antenna Factor	Preamp Factor	A/Pos	T/Pos	Pol/Phase	Remark
	MHz	dBuV/m	dBuV/m	dB	dBuV	dB	dB/m	dB	cm	deg		
1 pk	11592.28	58.72	74.00	-15.28	45.49	9.11	38.97	34.85	100	99	VERTICAL	Peak
2 pp	11592.84	47.09	54.00	-6.91	33.86	9.11	38.97	34.85	100	99	VERTICAL	Average



Temperature	24.5	Humidity	60%
Test Engineer	Serway Li	Configurations	IEEE 802.11ac MCS0 80MHz Ch 155 / Ant. 3 + Ant. 4 + Ant. 5 (3TX)
Test Date	Feb. 19, 2013		

*Horizontal*

	Freq	Level	Limit	Over	Read	Cable	Antenna	Preamp	Remark	A/Pos	T/Pos	Pol/Phase
	MHz	dBuV/m	dBuV/m	dB	dBuV	dB	dB/m	dB		cm	deg	
1	3849.99	53.83	74.00	-20.17	54.35	2.84	31.81	35.17	Peak	144	106	HORIZONTAL
2	3850.01	51.33	54.00	-2.67	51.85	2.84	31.81	35.17	Average	144	106	HORIZONTAL
3	11535.28	50.27	74.00	-23.73	41.62	5.13	38.81	35.29	Peak	100	62	HORIZONTAL
4	11544.56	36.79	54.00	-17.21	28.15	5.13	38.81	35.30	Average	100	62	HORIZONTAL

*Vertical*

	Freq	Level	Limit	Over	Read	Cable	Antenna	Preamp	Remark	A/Pos	T/Pos	Pol/Phase
	MHz	dBuV/m	dBuV/m	dB	dBuV	dB	dB/m	dB		cm	deg	
1	3849.95	50.84	74.00	-23.16	51.36	2.84	31.81	35.17	Peak	118	104	VERTICAL
2	3850.00	47.50	54.00	-6.50	48.02	2.84	31.81	35.17	Average	118	104	VERTICAL
3	11544.40	38.53	54.00	-15.47	29.89	5.13	38.81	35.30	Average	110	138	VERTICAL
4	11550.16	51.51	74.00	-22.49	42.87	5.13	38.81	35.30	Peak	110	138	VERTICAL



Temperature	25.6	Humidity	56%
Test Engineer	Robert Chang	Configurations	IEEE 802.11b Ch 1 / Ant. 2 (1TX)
Test Date	Jan. 22, 2013		

*Horizontal*

	Freq	Level	Limit Line	Over Limit	Read Level	Cable Loss	Antenna Factor	Preamp Factor	Remark	A/Pos	T/Pos	Pol/Phase
	MHz	dBuV/m	dBuV/m	dB	dBuV	dB	dB/m	dB		cm	deg	
1	4824.02	44.62	54.00	-9.38	43.28	3.31	33.06	35.03	Average	101	320	HORIZONTAL
2	4824.10	46.70	74.00	-27.30	45.36	3.31	33.06	35.03	Peak	101	320	HORIZONTAL

*Vertical*

	Freq	Level	Limit Line	Over Limit	Read Level	Cable Loss	Antenna Factor	Preamp Factor	Remark	A/Pos	T/Pos	Pol/Phase
	MHz	dBuV/m	dBuV/m	dB	dBuV	dB	dB/m	dB		cm	deg	
1	4824.02	44.80	54.00	-9.20	43.46	3.31	33.06	35.03	Average	138	128	VERTICAL
2	4824.04	47.54	74.00	-26.46	46.20	3.31	33.06	35.03	Peak	138	128	VERTICAL



Temperature	25.6	Humidity	56%
Test Engineer	Robert Chang	Configurations	IEEE 802.11b Ch 6 / Ant. 2 (1TX)
Test Date	Jan. 22, 2013		

*Horizontal*

	Freq	Level	Limit	Over	Read	Cable	Antenna	Preamp	Remark	A/Pos	T/Pos	Pol/Phase
	MHz	dBuV/m	dBuV/m	dB	dBuV	dB	dB/m	dB		cm	deg	
1	1624.68	47.15	74.00	-26.85	54.95	1.79	25.83	35.42	Peak	100	161	HORIZONTAL
2	1624.68	44.44	54.00	-9.56	52.24	1.79	25.83	35.42	Average	100	161	HORIZONTAL
3	4873.93	50.84	74.00	-23.16	49.38	3.33	33.16	35.03	Peak	100	274	HORIZONTAL
4	4874.02	46.58	54.00	-7.42	45.12	3.33	33.16	35.03	Average	100	274	HORIZONTAL
5	7310.31	39.40	54.00	-14.60	34.78	4.06	35.96	35.40	Average	101	309	HORIZONTAL
6	7311.90	49.74	74.00	-24.26	45.12	4.06	35.96	35.40	Peak	101	309	HORIZONTAL

*Vertical*

	Freq	Level	Limit	Over	Read	Cable	Antenna	Preamp	Remark	A/Pos	T/Pos	Pol/Phase
	MHz	dBuV/m	dBuV/m	dB	dBuV	dB	dB/m	dB		cm	deg	
1	1624.64	49.72	74.00	-24.28	57.52	1.79	25.83	35.42	Peak	100	251	VERTICAL
2	1624.66	47.81	54.00	-6.19	55.61	1.79	25.83	35.42	Average	100	251	VERTICAL
3	4873.94	54.32	74.00	-19.68	52.86	3.33	33.16	35.03	Peak	100	341	VERTICAL
4	4874.02	51.36	54.00	-2.64	49.90	3.33	33.16	35.03	Average	100	341	VERTICAL
5	7310.01	54.39	74.00	-19.61	49.77	4.06	35.96	35.40	Peak	114	319	VERTICAL
6	7310.30	47.60	54.00	-6.40	42.98	4.06	35.96	35.40	Average	114	319	VERTICAL





Temperature	25.6	Humidity	56%
Test Engineer	Robert Chang	Configurations	IEEE 802.11b Ch 11 / Ant. 2 (1TX)
Test Date	Jan. 22, 2013		

*Horizontal*

	Freq	Level	Limit	Over	Read	Cable	Antenna	Preamp	Remark	A/Pos	T/Pos	Pol/Phase
	MHz	dBuV/m	dBuV/m	dB	dBuV	Loss	Factor	Factor		cm	deg	
1	4924.03	44.58	54.00	-9.42	42.98	3.35	33.26	35.01	Average	100	158	HORIZONTAL
2	4924.06	49.98	74.00	-24.02	48.38	3.35	33.26	35.01	Peak	100	158	HORIZONTAL
3	7385.87	47.51	74.00	-26.49	42.76	4.06	36.09	35.40	Peak	103	207	HORIZONTAL
4	7386.87	35.26	54.00	-18.74	30.51	4.06	36.09	35.40	Average	103	207	HORIZONTAL

*Vertical*

	Freq	Level	Limit	Over	Read	Cable	Antenna	Preamp	Remark	A/Pos	T/Pos	Pol/Phase
	MHz	dBuV/m	dBuV/m	dB	dBuV	Loss	Factor	Factor		cm	deg	
1	4924.03	50.85	74.00	-23.15	49.25	3.35	33.26	35.01	Peak	114	212	VERTICAL
2	4924.04	46.42	54.00	-7.58	44.82	3.35	33.26	35.01	Average	114	212	VERTICAL
3	7385.34	42.46	54.00	-11.54	37.71	4.06	36.09	35.40	Average	103	141	VERTICAL
4	7386.85	51.02	74.00	-22.98	46.27	4.06	36.09	35.40	Peak	103	141	VERTICAL



<b>Temperature</b>	25.6	<b>Humidity</b>	56%
<b>Test Engineer</b>	Robert Chang	<b>Configurations</b>	IEEE 802.11g Ch 1 / Ant. 1 + Ant. 2 (2TX)
<b>Test Date</b>	Jan. 22, 2013		

*Horizontal*

	Freq	Level	Limit Line	Over Limit	Read Level	Cable Loss	Antenna Factor	Preamp Factor	Remark	A/Pos	T/Pos	Pol/Phase
	MHz	dBuV/m	dBuV/m	dB	dBuV	dB	dB/m	dB		cm	deg	
1	4800.02	49.99	74.00	-24.01	48.75	3.29	32.99	35.04	Peak	163	99	HORIZONTAL
2	4800.06	46.59	54.00	-7.41	45.35	3.29	32.99	35.04	Average	163	99	HORIZONTAL
3	4823.70	45.73	74.00	-28.27	44.39	3.31	33.06	35.03	Peak	152	131	HORIZONTAL
4	4823.87	32.55	54.00	-21.45	31.21	3.31	33.06	35.03	Average	152	131	HORIZONTAL

*Vertical*

	Freq	Level	Limit Line	Over Limit	Read Level	Cable Loss	Antenna Factor	Preamp Factor	Remark	A/Pos	T/Pos	Pol/Phase
	MHz	dBuV/m	dBuV/m	dB	dBuV	dB	dB/m	dB		cm	deg	
1	4799.93	53.24	74.00	-20.76	52.00	3.29	32.99	35.04	Peak	118	89	VERTICAL
2	4800.04	50.43	54.00	-3.57	49.19	3.29	32.99	35.04	Average	118	89	VERTICAL
3	4821.84	31.08	54.00	-22.92	29.74	3.31	33.06	35.03	Average	100	292	VERTICAL
4	4826.08	46.58	74.00	-27.42	45.24	3.31	33.06	35.03	Peak	100	292	VERTICAL



<b>Temperature</b>	25.6	<b>Humidity</b>	56%
<b>Test Engineer</b>	Robert Chang	<b>Configurations</b>	IEEE 802.11g Ch 6 / Ant. 1 + Ant. 2 (2TX)
<b>Test Date</b>	Jan. 22, 2013		

*Horizontal*

	Freq	Level	Limit	Over	Read	CableAntenna	Preamp	Remark	A/Pos	T/Pos	Pol/Phase
	MHz	dBuV/m	dBuV/m	dB	dBuV	dB	dB/m	dB	cm	deg	
1	4873.34	36.14	54.00	-17.86	34.68	3.33	33.16	35.03	Average	100	92 HORIZONTAL
2	4873.36	49.69	74.00	-24.31	48.23	3.33	33.16	35.03	Peak	100	92 HORIZONTAL
3	7309.73	56.13	74.00	-17.87	51.51	4.06	35.96	35.40	Peak	104	52 HORIZONTAL
4	7309.85	41.70	54.00	-12.30	37.08	4.06	35.96	35.40	Average	104	52 HORIZONTAL

*Vertical*

	Freq	Level	Limit	Over	Read	CableAntenna	Preamp	Remark	A/Pos	T/Pos	Pol/Phase
	MHz	dBuV/m	dBuV/m	dB	dBuV	dB	dB/m	dB	cm	deg	
1	4872.69	40.47	54.00	-13.53	39.01	3.33	33.16	35.03	Average	100	204 VERTICAL
2	4872.91	58.35	74.00	-15.65	56.89	3.33	33.16	35.03	Peak	100	204 VERTICAL
3	7314.61	43.00	54.00	-11.00	38.38	4.06	35.96	35.40	Average	100	71 VERTICAL
4	7315.28	58.75	74.00	-15.25	54.13	4.06	35.96	35.40	Peak	100	71 VERTICAL



<b>Temperature</b>	25.6	<b>Humidity</b>	56%
<b>Test Engineer</b>	Robert Chang	<b>Configurations</b>	IEEE 802.11g Ch 11 / Ant. 1 + Ant. 2 (2TX)
<b>Test Date</b>	Jan. 22, 2013		

*Horizontal*

	Freq	Level	Limit Line	Over Limit	Read Level	Cable Loss	Antenna Factor	Preamp Factor	Remark	A/Pos	T/Pos	Pol/Phase
	MHz	dBuV/m	dBuV/m	dB	dBuV	dB	dB/m	dB		cm	deg	
1	4924.01	33.02	54.00	-20.98	31.42	3.35	33.26	35.01	Average	128	1	HORIZONTAL
2	4924.71	46.19	74.00	-27.81	44.59	3.35	33.26	35.01	Peak	128	1	HORIZONTAL
3	7385.18	35.38	54.00	-18.62	30.63	4.06	36.09	35.40	Average	100	360	HORIZONTAL
4	7386.18	48.26	74.00	-25.74	43.51	4.06	36.09	35.40	Peak	100	360	HORIZONTAL

*Vertical*

	Freq	Level	Limit Line	Over Limit	Read Level	Cable Loss	Antenna Factor	Preamp Factor	Remark	A/Pos	T/Pos	Pol/Phase
	MHz	dBuV/m	dBuV/m	dB	dBuV	dB	dB/m	dB		cm	deg	
1	4924.65	32.86	54.00	-21.14	31.26	3.35	33.26	35.01	Average	113	342	VERTICAL
2	4924.81	44.71	74.00	-29.29	43.11	3.35	33.26	35.01	Peak	113	342	VERTICAL
3	7385.60	50.21	74.00	-23.79	45.46	4.06	36.09	35.40	Peak	106	9	VERTICAL
4	7385.76	36.91	54.00	-17.09	32.16	4.06	36.09	35.40	Average	106	9	VERTICAL



<b>Temperature</b>	25.6	<b>Humidity</b>	56%
<b>Test Engineer</b>	Robert Chang	<b>Configurations</b>	IEEE 802.11a Ch 149 / Ant. 3 + Ant. 4 + Ant. 5 (3TX)
<b>Test Date</b>	Jan. 22, 2013		

*Horizontal*

	Freq	Level	Limit Line	Over Limit	Read Level	CableAntenna Loss	Antenna Factor	Preamp Factor	Remark	A/Pos	T/Pos	Pol/Phase
	MHz	dBuV/m	dBuV/m	dB	dBuV	dB	dB/m	dB		cm	deg	
1	3829.99	51.21	54.00	-2.79	51.90	2.84	31.64	35.17	Average	126	112	HORIZONTAL
2	3830.03	53.72	74.00	-20.28	54.41	2.84	31.64	35.17	Peak	126	112	HORIZONTAL
3	11486.20	43.55	54.00	-10.45	34.94	5.11	38.78	35.28	Average	101	198	HORIZONTAL
4	11495.10	55.36	74.00	-18.64	46.74	5.12	38.78	35.28	Peak	101	198	HORIZONTAL

*Vertical*

	Freq	Level	Limit Line	Over Limit	Read Level	CableAntenna Loss	Antenna Factor	Preamp Factor	Remark	A/Pos	T/Pos	Pol/Phase
	MHz	dBuV/m	dBuV/m	dB	dBuV	dB	dB/m	dB		cm	deg	
1	3829.99	47.85	54.00	-6.15	48.54	2.84	31.64	35.17	Average	117	131	VERTICAL
2	3830.02	51.18	74.00	-22.82	51.87	2.84	31.64	35.17	Peak	117	131	VERTICAL
3	11485.20	56.29	74.00	-17.71	47.68	5.11	38.78	35.28	Peak	100	183	VERTICAL
4	11485.70	44.64	54.00	-9.36	36.03	5.11	38.78	35.28	Average	100	183	VERTICAL



Temperature	25.6	Humidity	56%
Test Engineer	Robert Chang	Configurations	IEEE 802.11a Ch 157 / Ant. 3 + Ant. 4 + Ant. 5 (3TX)
Test Date	Jan. 22, 2013		

*Horizontal*

	Freq	Level	Limit Line	Over Limit	Read Level	Cable Loss	Antenna Factor	Preamp Factor	Remark	A/Pos	T/Pos	Pol/Phase
	MHz	dBuV/m	dBuV/m	dB	dBuV	dB	dB/m	dB		cm	deg	
1	3856.64	50.08	54.00	-3.92	50.59	2.84	31.81	35.16	Average	141	75	HORIZONTAL
2	3856.65	52.49	74.00	-21.51	53.00	2.84	31.81	35.16	Peak	141	75	HORIZONTAL
3	11570.60	52.97	74.00	-21.03	44.30	5.14	38.83	35.30	Peak	101	143	HORIZONTAL
4	11572.80	40.89	54.00	-13.11	32.22	5.14	38.83	35.30	Average	101	143	HORIZONTAL

*Vertical*

	Freq	Level	Limit Line	Over Limit	Read Level	Cable Loss	Antenna Factor	Preamp Factor	Remark	A/Pos	T/Pos	Pol/Phase
	MHz	dBuV/m	dBuV/m	dB	dBuV	dB	dB/m	dB		cm	deg	
1	3856.59	52.97	74.00	-21.03	53.48	2.84	31.81	35.16	Peak	141	57	VERTICAL
2	3856.66	50.33	54.00	-3.67	50.84	2.84	31.81	35.16	Average	141	57	VERTICAL
3	11570.30	52.23	74.00	-21.77	43.56	5.14	38.83	35.30	Peak	100	193	VERTICAL
4	11572.80	40.25	54.00	-13.75	31.58	5.14	38.83	35.30	Average	100	193	VERTICAL



<b>Temperature</b>	25.6	<b>Humidity</b>	56%
<b>Test Engineer</b>	Robert Chang	<b>Configurations</b>	IEEE 802.11a Ch 165 / Ant. 3 + Ant. 4 + Ant. 5 (3TX)
<b>Test Date</b>	Jan. 22, 2013		

**Horizontal**

	Freq	Level	Limit	Over	Read	Cable	Antenna	Preamp	Remark	A/Pos	T/Pos	Pol/Phase
	MHz	dBuV/m	dBuV/m	dB	dBuV	dB	dB/m	dB		cm	deg	
1	3883.27	54.52	74.00	-19.48	54.85	2.84	31.98	35.15	Peak	141	134	HORIZONTAL
2	3883.32	50.74	54.00	-3.26	51.07	2.84	31.98	35.15	Average	141	134	HORIZONTAL
3	11650.30	41.29	54.00	-12.71	32.57	5.16	38.86	35.30	Average	115	305	HORIZONTAL
4	11652.10	52.23	74.00	-21.77	43.51	5.16	38.86	35.30	Peak	115	305	HORIZONTAL

**Vertical**

	Freq	Level	Limit	Over	Read	Cable	Antenna	Preamp	Remark	A/Pos	T/Pos	Pol/Phase
	MHz	dBuV/m	dBuV/m	dB	dBuV	dB	dB/m	dB		cm	deg	
1	3883.22	50.78	74.00	-23.22	51.11	2.84	31.98	35.15	Peak	116	337	VERTICAL
2	3883.32	47.43	54.00	-6.57	47.76	2.84	31.98	35.15	Average	116	337	VERTICAL
3	11648.50	42.80	54.00	-11.20	34.08	5.16	38.86	35.30	Average	100	152	VERTICAL
4	11648.70	54.78	74.00	-19.22	46.06	5.16	38.86	35.30	Peak	100	152	VERTICAL

**Note:**

The amplitude of spurious emissions that are attenuated by more than 20dB below the permissible value has no need to be reported.

Emission level (dBuV/m) = 20 log Emission level (uV/m).

Corrected Reading: Antenna Factor + Cable Loss + Read Level - Preamp Factor = Level.

## 4.6. Emissions Measurement

### 4.6.1. Limit

30dBc in any 100 kHz bandwidth outside the operating frequency band. In case the emission fall within the restricted band specified on 15.205(a), then the 15.209(a) limit in the table below has to be followed.

Frequencies (MHz)	Field Strength (micorvolts/meter)	Measurement Distance (meters)
0.009~0.490	2400/F(KHz)	300
0.490~1.705	24000/F(KHz)	30
1.705~30.0	30	30
30~88	100	3
88~216	150	3
216~960	200	3
Above 960	500	3

### 4.6.2. Measuring Instruments and Setting

Please refer to section 5 of equipments list in this report. The following table is the setting of the spectrum analyzer.

Spectrum Parameter	Setting
Attenuation	Auto
Span Frequency	100 MHz
RB / VB (Emission in restricted band)	1MHz / 3MHz for Peak, 1 MHz / 10Hz for Average
RB / VB (Emission in non-restricted band)	100 kHz / 300 kHz for Peak

### 4.6.3. Test Procedures

For Radiated band edges Measurement:

1. The test procedure is the same as section 4.5.3, only the frequency range investigated is limited to 100MHz around band edges.

For Conducted Out of Band Emission Measurement:

1. Test was performed in accordance with KDB 558074 v02 Guidance for Performing Compliance Measurements on Digital Transmission Systems (DTS) Operating Under §15.247 section 10.1 Unwanted Emissions into Non-Restricted Frequency Bands Measurement Procedure

2. The conducted emission test is performed on each TX port of operating mode without summing or adding  $10\log(N)$  since the limit is relative emission limit.

Only worst data of each operating mode is presented.



#### **4.6.4. Test Setup Layout**

For Radiated band edges Measurement:

This test setup layout is the same as that shown in section 4.5.4.

For Conducted Out of Band Emission Measurement:

This test setup layout is the same as that shown in section 4.4.4.

#### **4.6.5. Test Deviation**

There is no deviation with the original standard.

#### **4.6.6. EUT Operation during Test**

The EUT was programmed to be in continuously transmitting mode.

#### 4.6.7. Test Result of Band Edge and Fundamental Emissions

Temperature	25.6°C	Humidity	56%
Test Engineer	Magic Lai	Configurations	IEEE 802.11n MCS0 20MHz Ch 1, 6, 11 / Ant. 1 + Ant. 2 (2TX)
Test date	Jan. 20, 2013		

##### Channel 1

	Freq	Level	Limit Line	Over Limit	Read Level	CableAntenna Loss	Antenna Factor	Preamp Factor	Remark	A/Pos	T/Pos	Pol/Phase
	MHz	dBuV/m	dBuV/m	dB	dBuV	dB	dB/m	dB		cm	deg	
1	2390.00	53.81	54.00	-0.19	23.42	2.22	28.17	0.00	Average	160	97	HORIZONTAL
2	2390.00	68.49	74.00	-5.51	38.10	2.22	28.17	0.00	Peak	160	97	HORIZONTAL
3	2409.44	101.76			71.33	2.22	28.21	0.00	Average	160	97	HORIZONTAL
4	2409.60	111.69			81.26	2.22	28.21	0.00	Peak	160	97	HORIZONTAL

Item 3, 4 are the fundamental frequency at 2412 MHz.

##### Channel 6

	Freq	Level	Limit Line	Over Limit	Read Level	CableAntenna Loss	Antenna Factor	Preamp Factor	Remark	A/Pos	T/Pos	Pol/Phase
	MHz	dBuV/m	dBuV/m	dB	dBuV	dB	dB/m	dB		cm	deg	
1	2388.40	65.53	74.00	-8.47	35.15	2.21	28.17	0.00	Peak	122	81	HORIZONTAL
2	2390.00	51.38	54.00	-2.62	20.99	2.22	28.17	0.00	Average	122	81	HORIZONTAL
3	2434.60	108.49			77.97	2.23	28.29	0.00	Average	122	81	HORIZONTAL
4	2434.76	119.41			88.89	2.23	28.29	0.00	Peak	122	81	HORIZONTAL
5	2484.14	67.98	74.00	-6.02	37.34	2.26	28.38	0.00	Peak	122	81	HORIZONTAL
6	2484.46	53.52	54.00	-0.48	22.88	2.26	28.38	0.00	Average	122	81	HORIZONTAL

Item 3, 4 are the fundamental frequency at 2437MHz.

##### Channel 11

	Freq	Level	Limit Line	Over Limit	Read Level	CableAntenna Loss	Antenna Factor	Preamp Factor	Remark	A/Pos	T/Pos	Pol/Phase
	MHz	dBuV/m	dBuV/m	dB	dBuV	dB	dB/m	dB		cm	deg	
1	2459.44	102.85			72.28	2.24	28.33	0.00	Average	156	346	HORIZONTAL
2	2464.56	113.35			82.78	2.24	28.33	0.00	Peak	156	346	HORIZONTAL
3	2483.98	70.92	74.00	-3.08	40.28	2.26	28.38	0.00	Peak	156	346	HORIZONTAL
4	2484.46	53.98	54.00	-0.02	23.34	2.26	28.38	0.00	Average	156	346	HORIZONTAL

Item 1, 2 are the fundamental frequency at 2462 MHz.

Temperature	25.6°C	Humidity	56%
Test Engineer	Magic Lai	Configurations	IEEE 802.11n MCS0 40MHz Ch 3, 6, 9 / Ant. 1 + Ant. 2 (2TX)
Test date	Jan. 20, 2013		

### Channel 3

	Freq	Level	Limit Line	Over Limit	Read Level	Cable Loss	Antenna Factor	Preamp Factor	Remark	A/Pos	T/Pos	Pol/Phase
	MHz	dBuV/m	dBuV/m	dB	dBuV	dB	dB/m	dB		cm	deg	
1	2390.00	53.73	54.00	-0.27	23.34	2.22	28.17	0.00	Average	123	31	HORIZONTAL
2	2390.00	67.31	74.00	-6.69	36.92	2.22	28.17	0.00	Peak	123	31	HORIZONTAL
3	2424.56	106.23			75.75	2.23	28.25	0.00	Peak	123	31	HORIZONTAL
4	2426.81	96.24			65.76	2.23	28.25	0.00	Average	123	31	HORIZONTAL

Item 3, 4 are the fundamental frequency at 2422 MHz.

### Channel 6

	Freq	Level	Limit Line	Over Limit	Read Level	Cable Loss	Antenna Factor	Preamp Factor	Remark	A/Pos	T/Pos	Pol/Phase
	MHz	dBuV/m	dBuV/m	dB	dBuV	dB	dB/m	dB		cm	deg	
1	2389.68	51.52	54.00	-2.48	21.14	2.21	28.17	0.00	Average	152	272	HORIZONTAL
2	2390.00	66.10	74.00	-7.90	35.71	2.22	28.17	0.00	Peak	152	272	HORIZONTAL
3	2431.87	100.53			70.05	2.23	28.25	0.00	Average	152	272	HORIZONTAL
4	2434.12	111.64			81.12	2.23	28.29	0.00	Peak	152	272	HORIZONTAL
5	2484.46	53.73	54.00	-0.27	23.09	2.26	28.38	0.00	Average	152	272	HORIZONTAL
6	2484.46	68.38	74.00	-5.62	37.74	2.26	28.38	0.00	Peak	152	272	HORIZONTAL

Item 3, 4 are the fundamental frequency at 2437MHz.

### Channel 9

	Freq	Level	Limit Line	Over Limit	Read Level	Cable Loss	Antenna Factor	Preamp Factor	Remark	A/Pos	T/Pos	Pol/Phase
	MHz	dBuV/m	dBuV/m	dB	dBuV	dB	dB/m	dB		cm	deg	
1	2446.87	96.13			65.60	2.24	28.29	0.00	Average	154	138	HORIZONTAL
2	2446.87	106.47			75.94	2.24	28.29	0.00	Peak	154	138	HORIZONTAL
3	2483.82	66.43	74.00	-7.57	35.79	2.26	28.38	0.00	Peak	154	138	HORIZONTAL
4	2484.78	53.15	54.00	-0.85	22.51	2.26	28.38	0.00	Average	154	138	HORIZONTAL

Item 1, 2 are the fundamental frequency at 2452 MHz.

Note:

Emission level (dBuV/m) = 20 log Emission level (uV/m).

Corrected Reading: Antenna Factor + Cable Loss + Read Level - Preamp Factor = Level.

Temperature	25.6°C	Humidity	56%
Test Engineer	Magic Lai	Configurations	IEEE 802.11b Ch 1, 6, 11 / Ant. 2 (1TX)
Test date	Jan. 20, 2013		

**Channel 1**

	Freq	Level	Limit Line	Over Limit	Read Level	CableAntenna Loss	Antenna Factor	Preamp Factor	Remark	A/Pos	T/Pos	Pol/Phase
	MHz	dBuV/m	dBuV/m	dB	dBuV	dB	dB/m	dB		cm	deg	
1	2390.00	53.54	54.00	-0.46	23.15	2.22	28.17	0.00	Average	123	155	HORIZONTAL
2	2390.00	64.82	74.00	-9.18	34.43	2.22	28.17	0.00	Peak	123	155	HORIZONTAL
3	2411.04	115.04			84.61	2.22	28.21	0.00	Peak	123	155	HORIZONTAL
4	2411.36	111.26			80.83	2.22	28.21	0.00	Average	123	155	HORIZONTAL

Item 3, 4 are the fundamental frequency at 2412 MHz.

**Channel 6**

	Freq	Level	Limit Line	Over Limit	Read Level	CableAntenna Loss	Antenna Factor	Preamp Factor	Remark	A/Pos	T/Pos	Pol/Phase
	MHz	dBuV/m	dBuV/m	dB	dBuV	dB	dB/m	dB		cm	deg	
1	2390.00	53.76	54.00	-0.24	23.37	2.22	28.17	0.00	Average	156	144	HORIZONTAL
2	2390.00	66.17	74.00	-7.83	35.78	2.22	28.17	0.00	Peak	156	144	HORIZONTAL
3	2436.36	115.15			84.63	2.23	28.29	0.00	Average	156	144	HORIZONTAL
4	2436.36	118.93			88.41	2.23	28.29	0.00	Peak	156	144	HORIZONTAL
5	2483.50	53.65	54.00	-0.35	23.01	2.26	28.38	0.00	Average	156	144	HORIZONTAL
6	2483.50	65.48	74.00	-8.52	34.84	2.26	28.38	0.00	Peak	156	144	HORIZONTAL

Item 3, 4 are the fundamental frequency at 2437 MHz.

**Channel 11**

	Freq	Level	Limit Line	Over Limit	Read Level	CableAntenna Loss	Antenna Factor	Preamp Factor	Remark	A/Pos	T/Pos	Pol/Phase
	MHz	dBuV/m	dBuV/m	dB	dBuV	dB	dB/m	dB		cm	deg	
1	2461.20	112.54			81.97	2.24	28.33	0.00	Average	141	86	HORIZONTAL
2	2461.20	117.08			86.51	2.24	28.33	0.00	Peak	141	86	HORIZONTAL
3	2483.50	53.82	54.00	-0.18	23.18	2.26	28.38	0.00	Average	141	86	HORIZONTAL
4	2484.30	67.00	74.00	-7.00	36.36	2.26	28.38	0.00	Peak	141	86	HORIZONTAL

Item 1, 2 are the fundamental frequency at 2462 MHz.

Temperature	25.6°C	Humidity	56%
Test Engineer	Magic Lai	Configurations	IEEE 802.11g Ch 1, 6, 11 / Ant. 1 + Ant. 2 (2TX)
Test date	Jan. 20, 2013		

**Channel 1**

	Freq	Level	Limit Line	Over Limit	Read Level	Cable Loss	Antenna Factor	Preamp Factor	Remark	A/Pos	T/Pos	Pol/Phase
	MHz	dBuV/m	dBuV/m	dB	dBuV	dB	dB/m	dB		cm	deg	
1	2388.24	68.78	74.00	-5.22	38.40	2.21	28.17	0.00	Peak	154	0	HORIZONTAL
2	2390.00	53.76	54.00	-0.24	23.37	2.22	28.17	0.00	Average	154	0	HORIZONTAL
3	2407.03	104.45			74.02	2.22	28.21	0.00	Average	154	0	HORIZONTAL
4	2416.33	114.59			84.15	2.23	28.21	0.00	Peak	154	0	HORIZONTAL

Item 3, 4 are the fundamental frequency at 2412 MHz.

**Channel 6**

	Freq	Level	Limit Line	Over Limit	Read Level	Cable Loss	Antenna Factor	Preamp Factor	Remark	A/Pos	T/Pos	Pol/Phase
	MHz	dBuV/m	dBuV/m	dB	dBuV	dB	dB/m	dB		cm	deg	
1	2389.84	67.23	74.00	-6.77	36.84	2.22	28.17	0.00	Peak	154	8	HORIZONTAL
2	2390.00	53.73	54.00	-0.27	23.34	2.22	28.17	0.00	Average	154	8	HORIZONTAL
3	2431.55	119.36			88.88	2.23	28.25	0.00	Peak	154	8	HORIZONTAL
4	2431.87	108.98			78.50	2.23	28.25	0.00	Average	154	8	HORIZONTAL
5	2486.20	53.39	54.00	-0.61	22.71	2.26	28.42	0.00	Average	154	8	HORIZONTAL
6	2486.68	67.92	74.00	-6.08	37.24	2.26	28.42	0.00	Peak	154	8	HORIZONTAL

Item 3, 4 are the fundamental frequency at 2437 MHz.

**Channel 11**

	Freq	Level	Limit Line	Over Limit	Read Level	Cable Loss	Antenna Factor	Preamp Factor	Remark	A/Pos	T/Pos	Pol/Phase
	MHz	dBuV/m	dBuV/m	dB	dBuV	dB	dB/m	dB		cm	deg	
1	2456.71	113.51			82.94	2.24	28.33	0.00	Peak	153	320	HORIZONTAL
2	2456.87	103.47			72.90	2.24	28.33	0.00	Average	153	320	HORIZONTAL
3	2483.50	53.68	54.00	-0.32	23.04	2.26	28.38	0.00	Average	153	320	HORIZONTAL
4	2483.50	68.33	74.00	-5.67	37.69	2.26	28.38	0.00	Peak	153	320	HORIZONTAL

Item 1, 2 are the fundamental frequency at 2462 MHz.

Note:

Emission level (dBuV/m) = 20 log Emission level (uV/m).

Corrected Reading: Antenna Factor + Cable Loss + Read Level - Preamp Factor = Level.

For Emission not in Restricted Band

Plot on Configuration IEEE 802.11n MCS0 20MHz / Reference Level

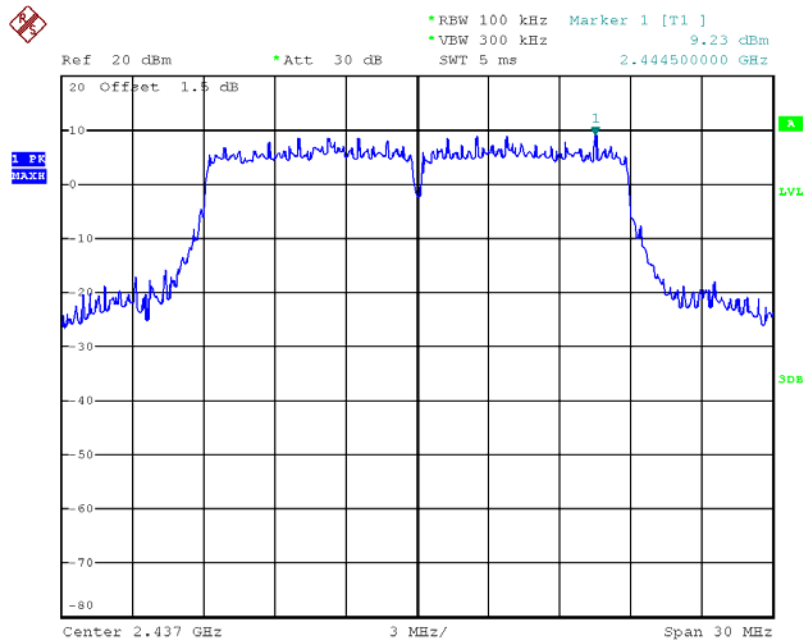

Date: 31.JAN.2013 10:42:10

Plot on Configuration IEEE 802.11n MCS0 20MHz / CH 1 (down 30dBc)

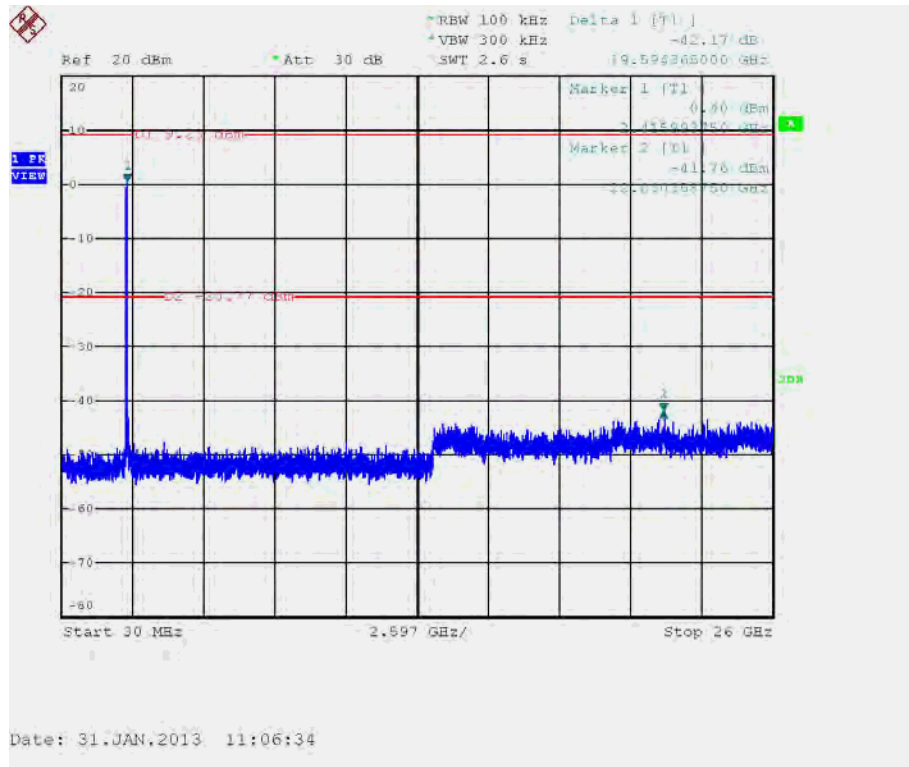

Plot on Configuration IEEE 802.11n MCS0 20MHz / CH 6 (down 30dBc)

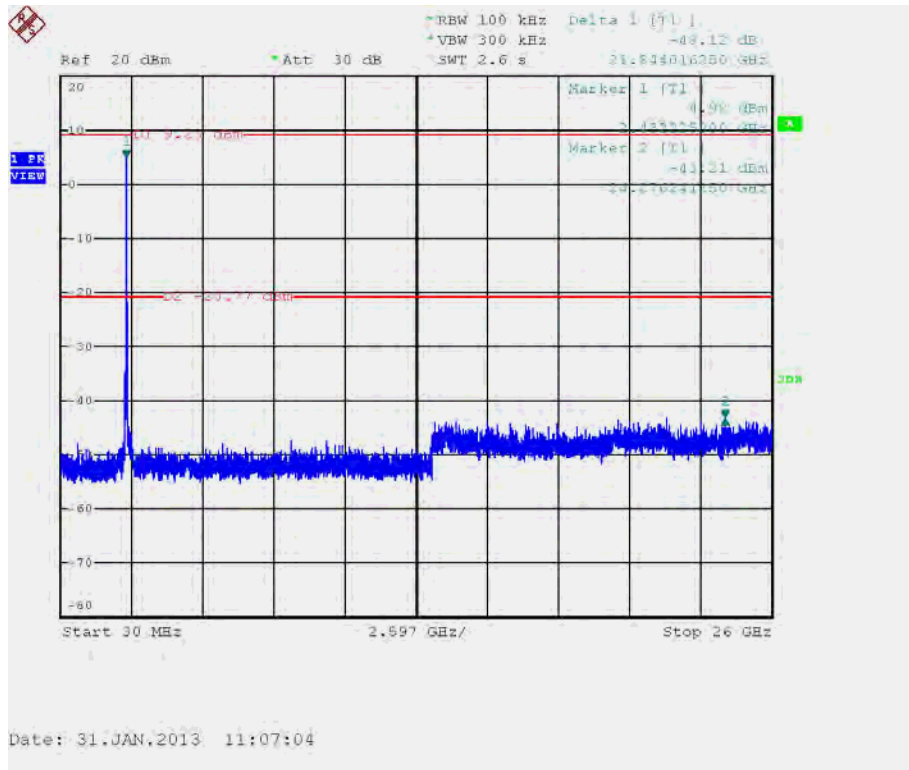

Plot on Configuration IEEE 802.11n MCS0 20MHz / CH 11 (down 30dBc)

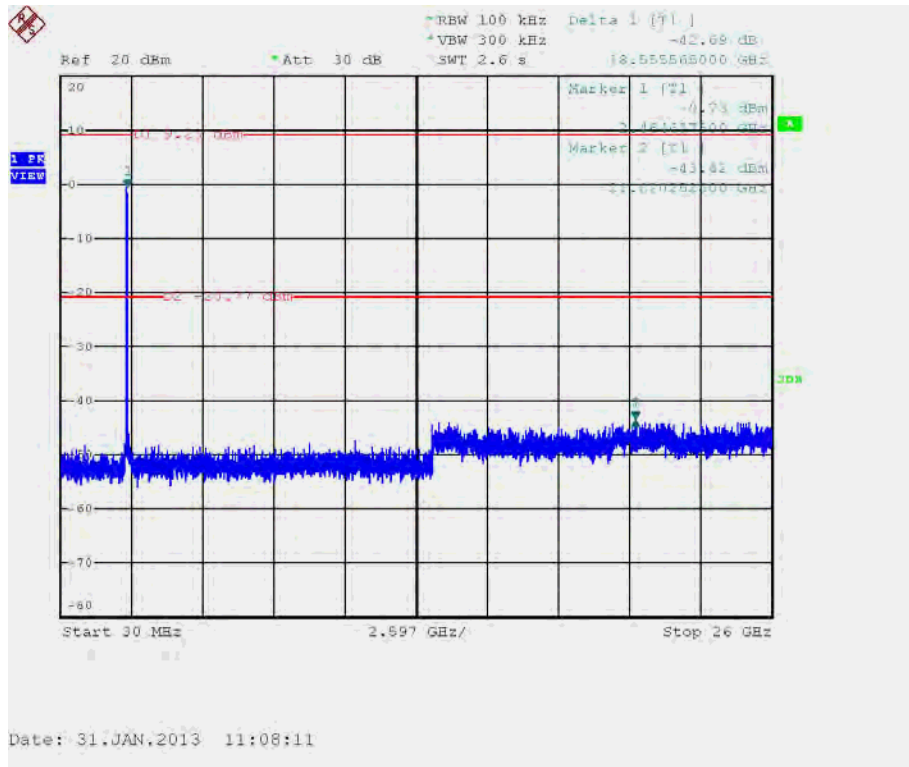

Plot on Configuration IEEE 802.11n MCS0 40MHz / Reference Level

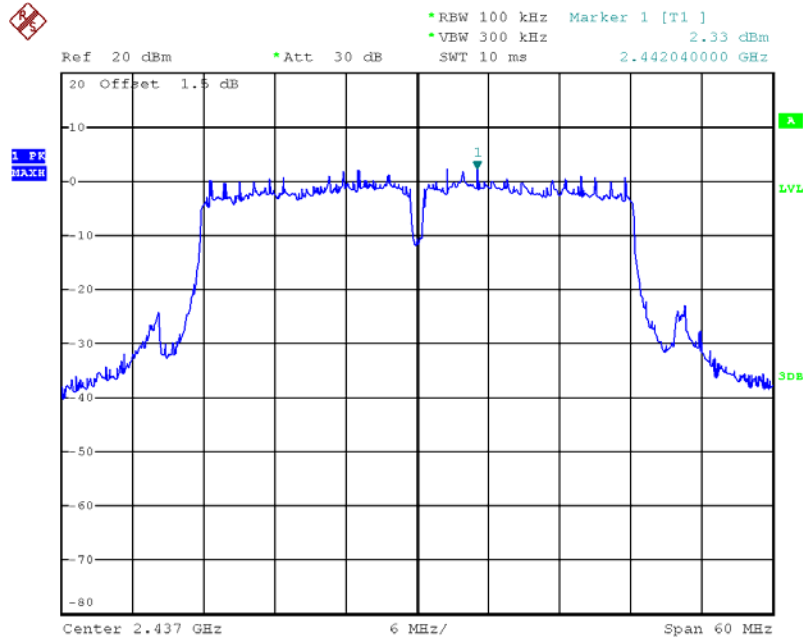

Date: 31.JAN.2013 10:48:25

Plot on Configuration IEEE 802.11n MCS0 40MHz / CH 3 (down 30dBc)

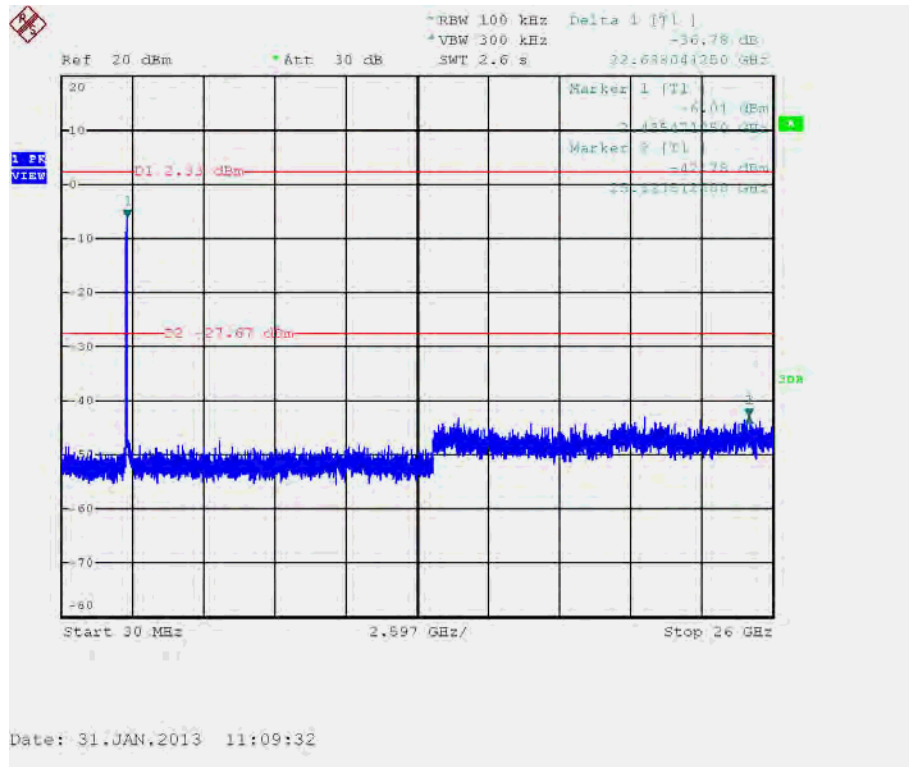



Plot on Configuration IEEE 802.11n MCS0 40MHz / CH 6 (down 30dBc)

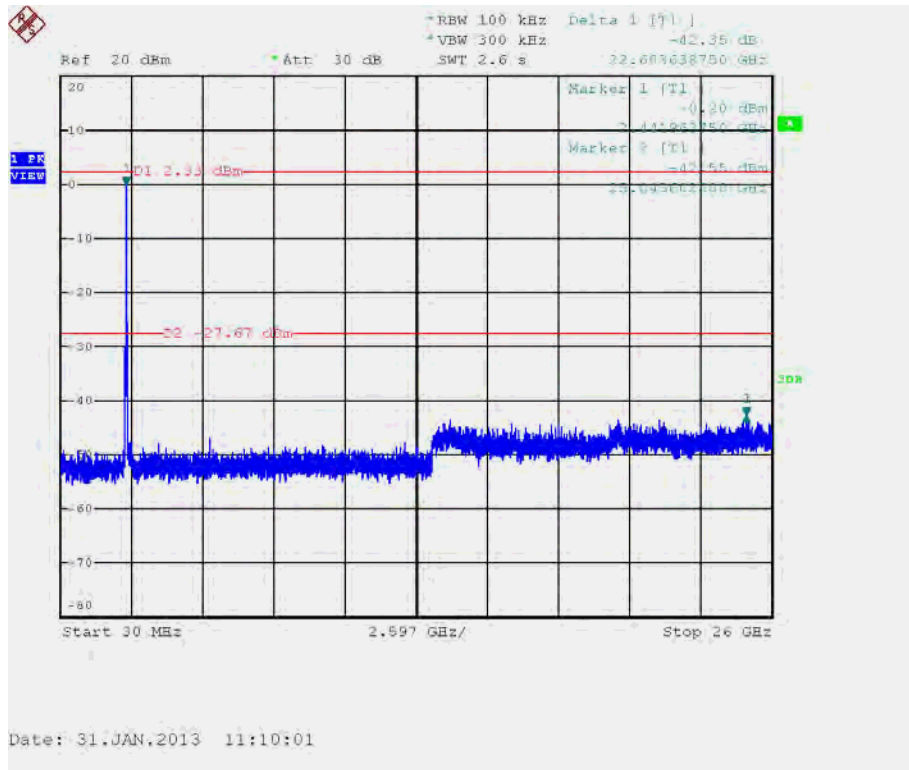

Plot on Configuration IEEE 802.11n MCS0 40MHz / CH 9 (down 30dBc)

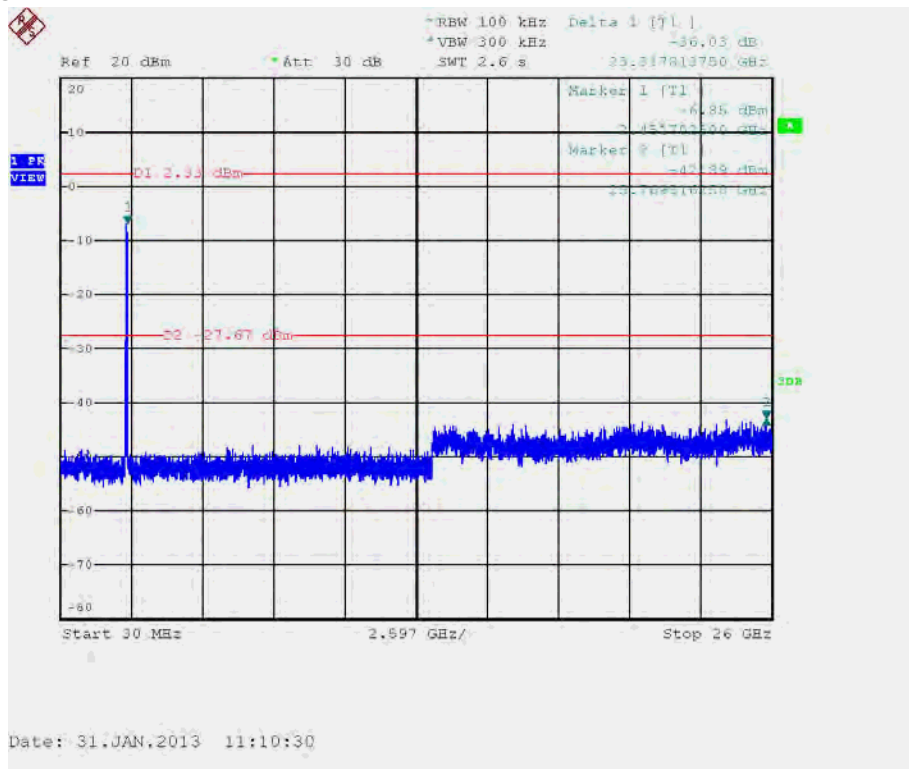

Plot on Configuration IEEE 802.11n MCS0 20MHz / Reference Level

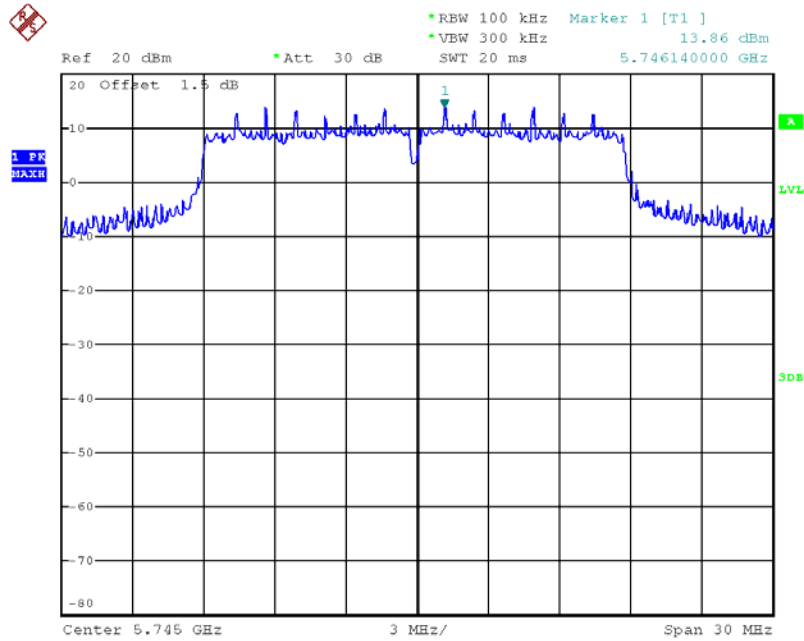

Date: 19.FEB.2013 13:30:43

Plot on Configuration IEEE 802.11n MCS0 20MHz / CH 149 (down 30dBc)

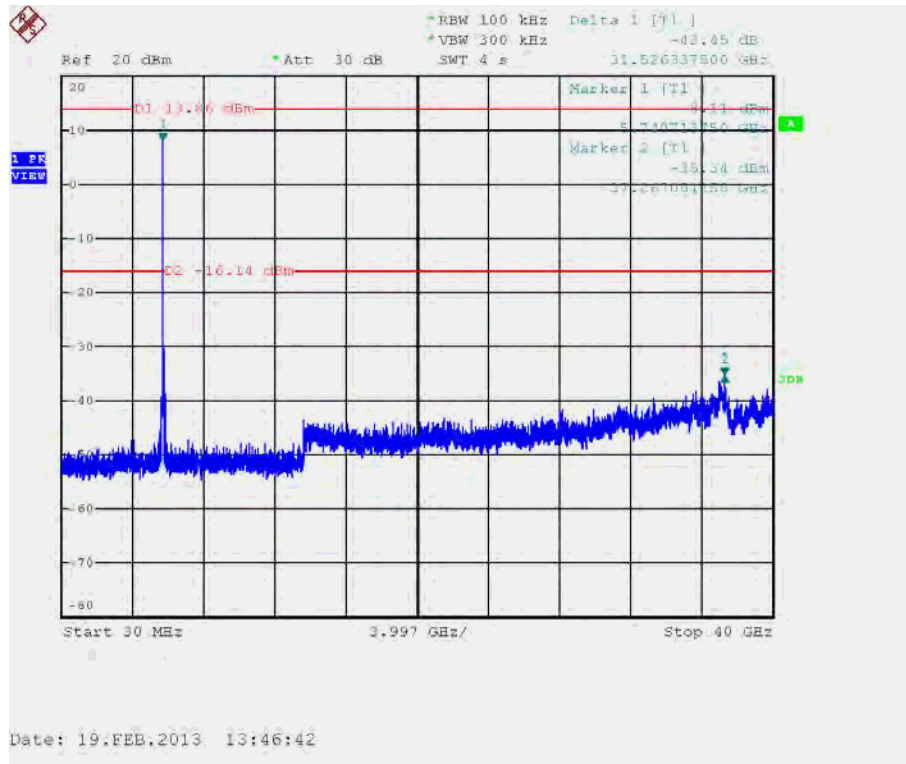

Plot on Configuration IEEE 802.11n MCS0 20MHz / CH 157 (down 30dBc)

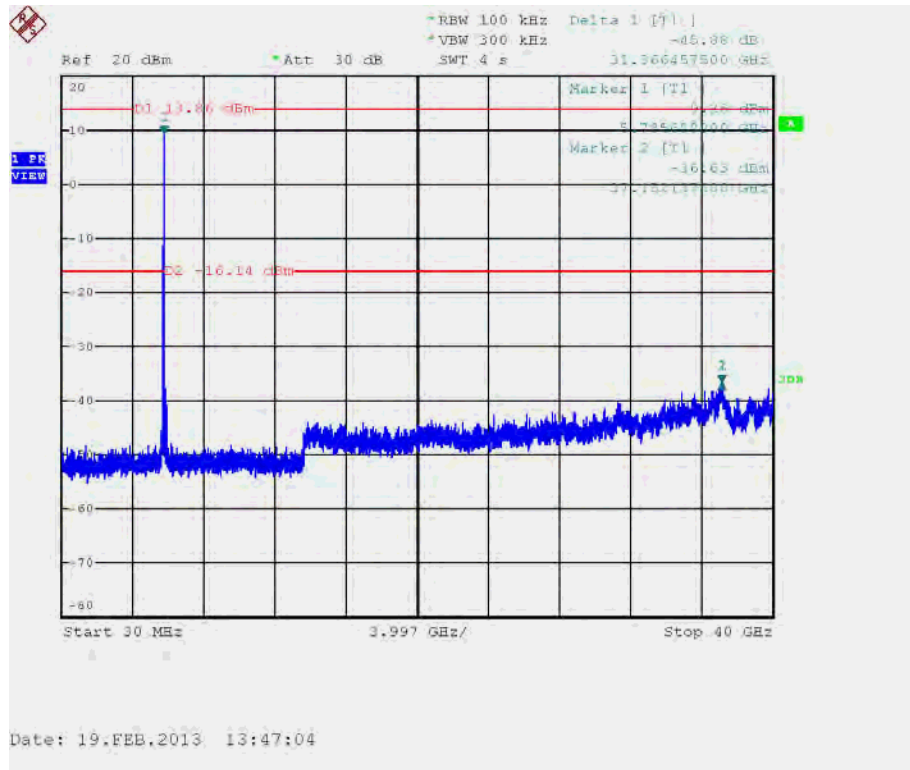

Plot on Configuration IEEE 802.11n MCS0 20MHz / CH 165 (down 30dBc)

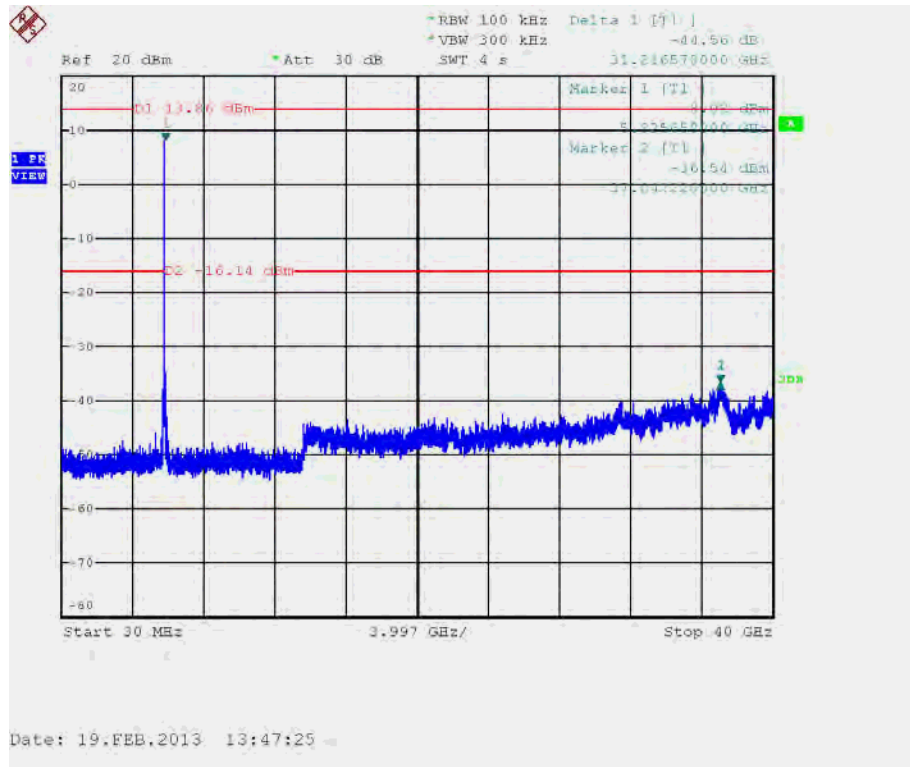

### Plot on Configuration IEEE 802.11n MCS0 40MHz / Reference Level

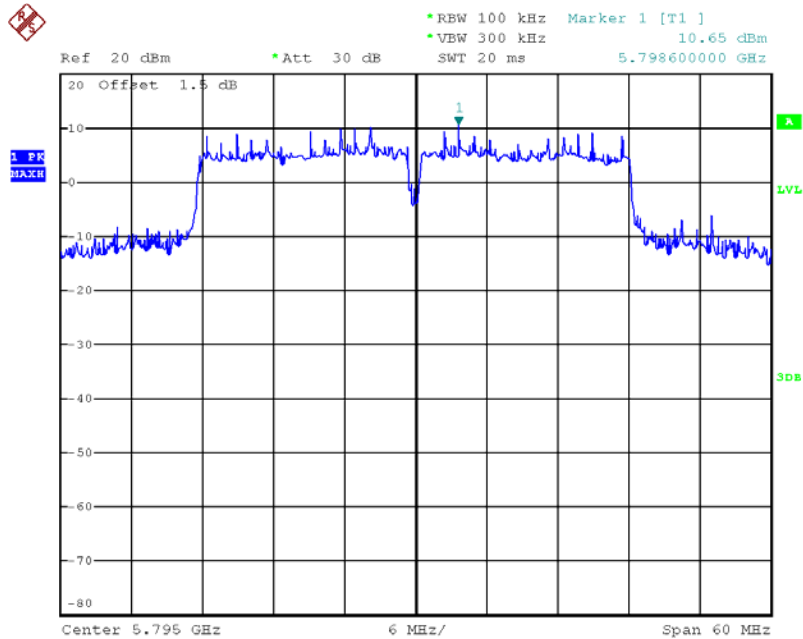

Date: 19.FEB.2013 13:36:39

### Plot on Configuration IEEE 802.11n MCS0 40MHz / CH 151 (down 30dBc)

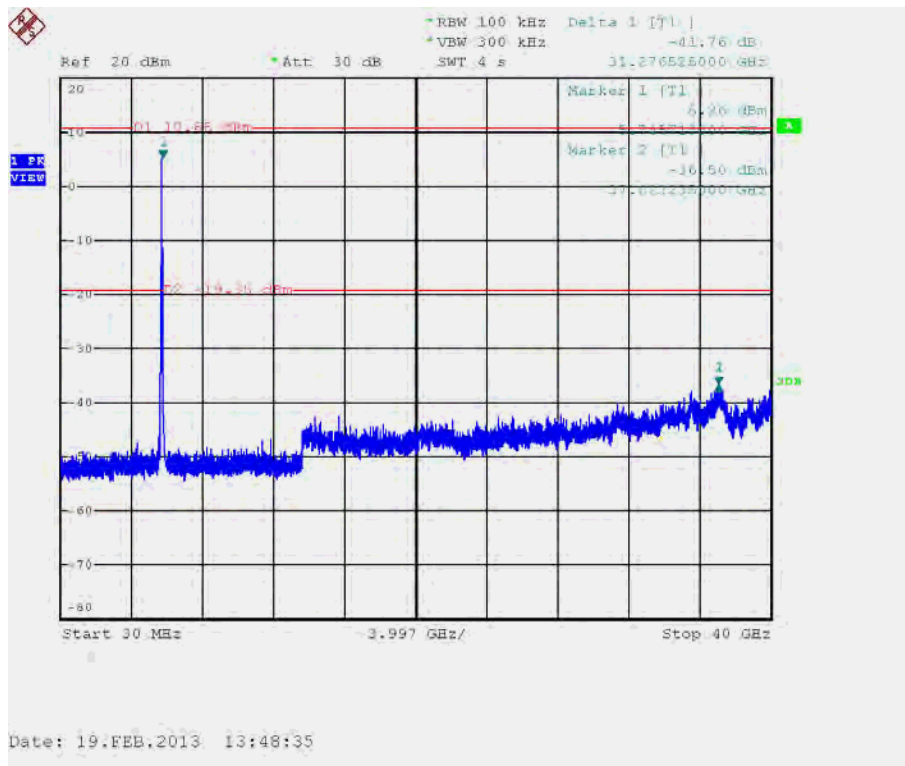

Plot on Configuration IEEE 802.11n MCS0 40MHz / CH 159 (down 30dBc)

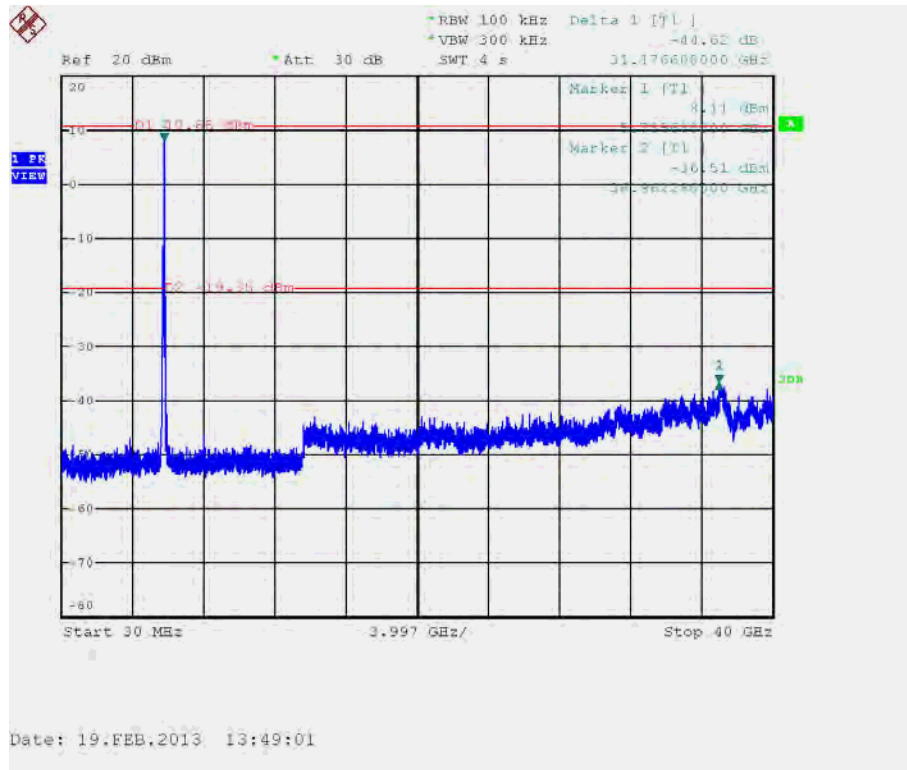

Plot on Configuration IEEE 802.11ac MCS0 80MHz / Reference Level

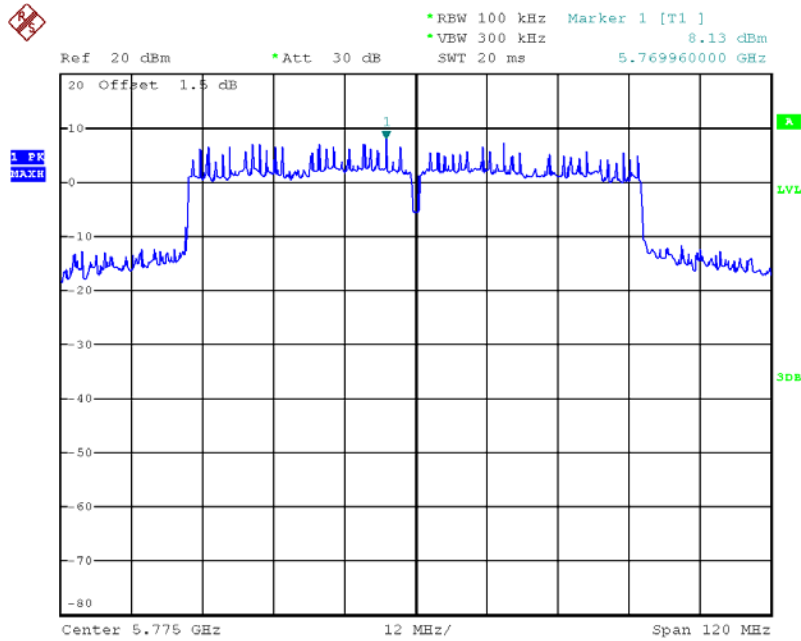

Date: 19.FEB.2013 13:39:32

Plot on Configuration IEEE 802.11ac MCS0 80MHz / CH 155 (down 30dBc)

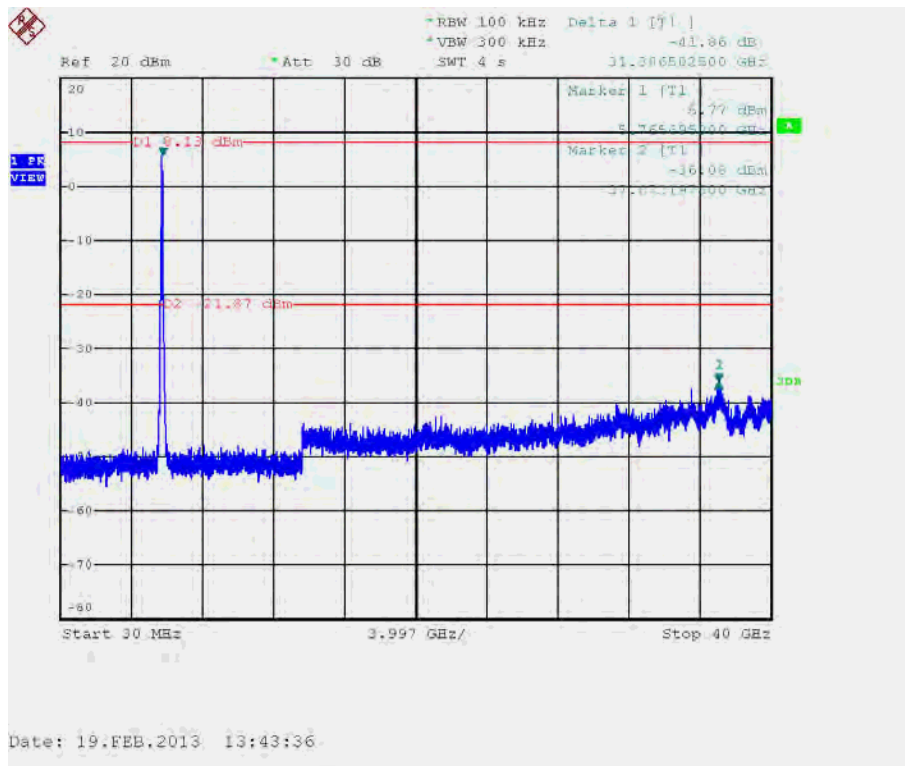

Plot on Configuration IEEE 802.11b / Reference Level

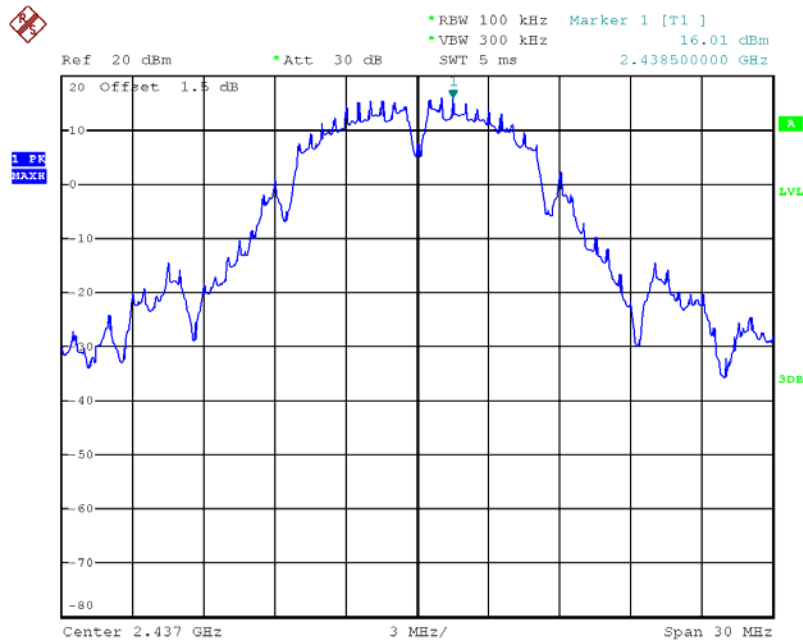

Date: 31.JAN.2013 10:32:03

Plot on Configuration IEEE 802.11b / CH 1 (down 30dBc)

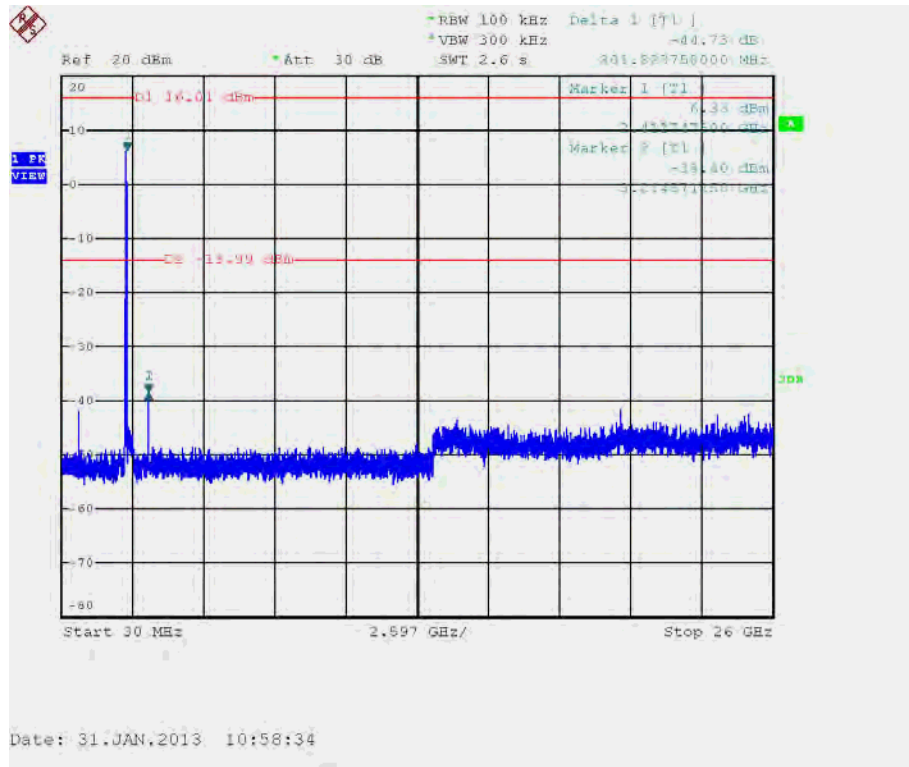

Plot on Configuration IEEE 802.11b / CH 6 (down 30dBc)

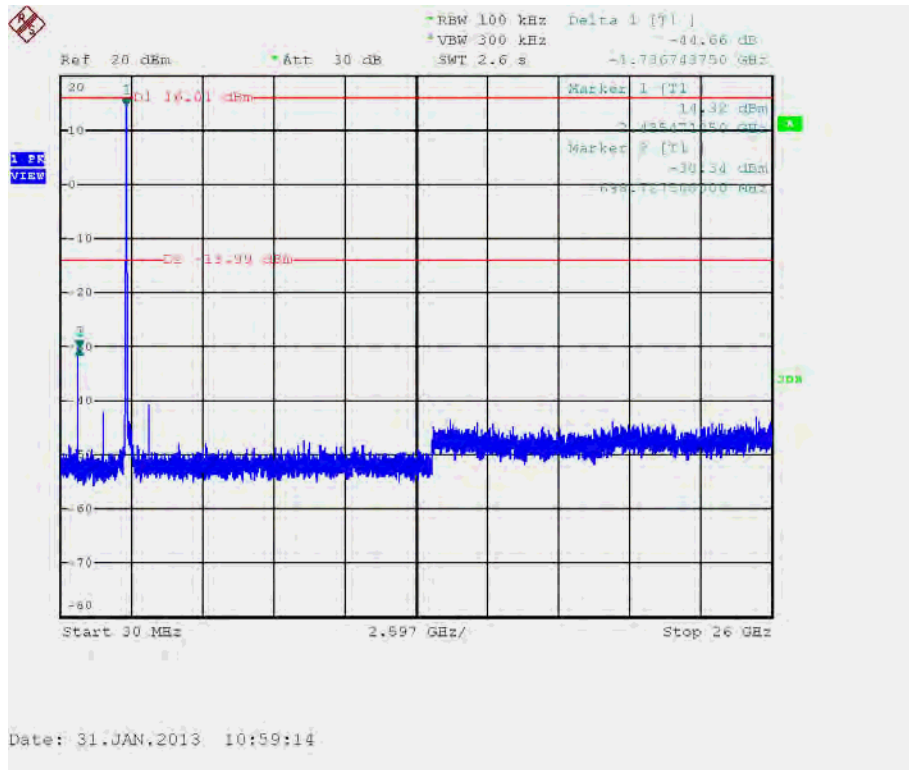

Plot on Configuration IEEE 802.11b / CH 11 (down 30dBc)

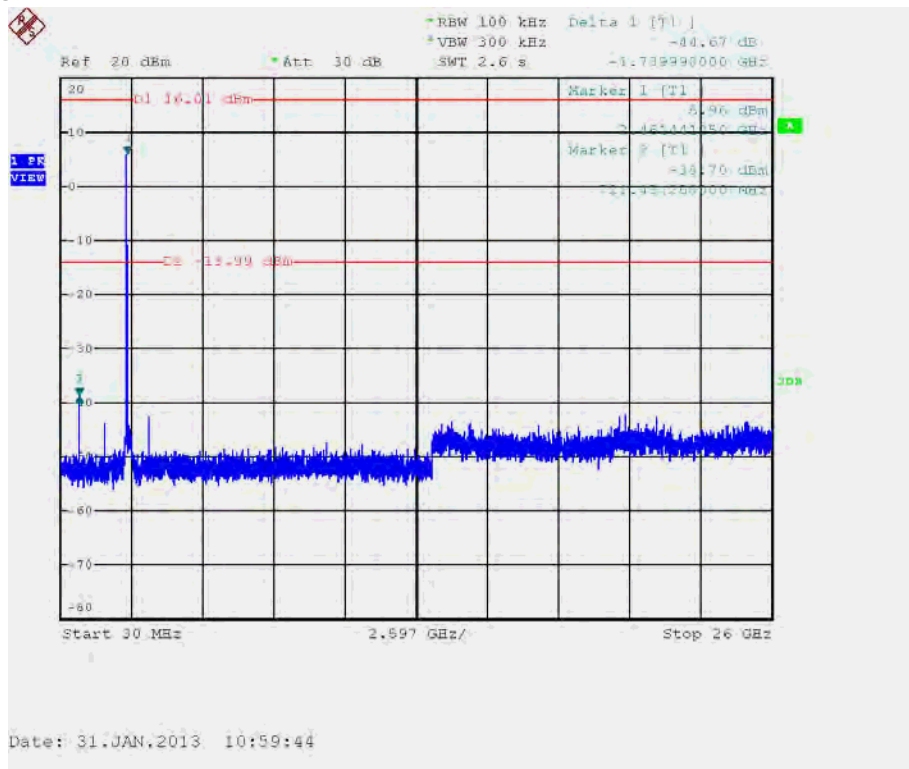



Plot on Configuration IEEE 802.11g / Reference Level

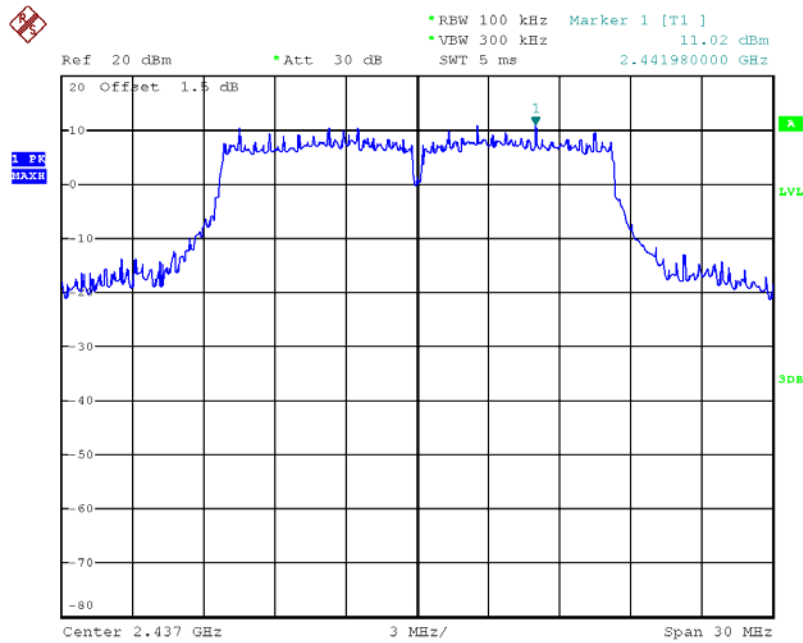

Date: 31.JAN.2013 10:39:01

Plot on Configuration IEEE 802.11g / CH 1 (down 30dBc)

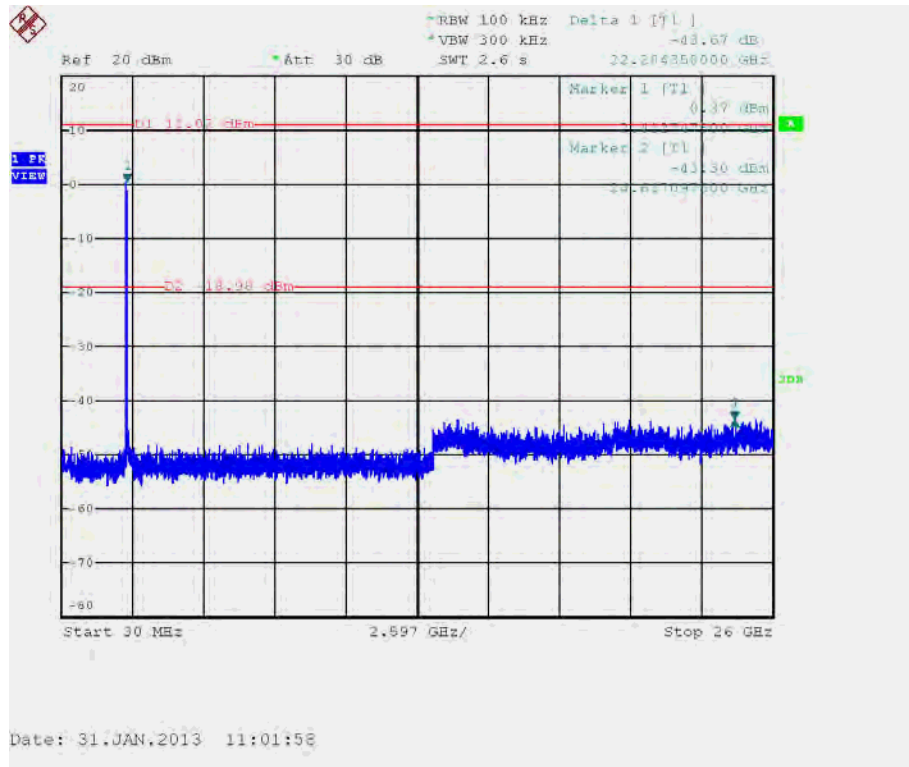

Plot on Configuration IEEE 802.11g / CH 6 (down 30dBc)

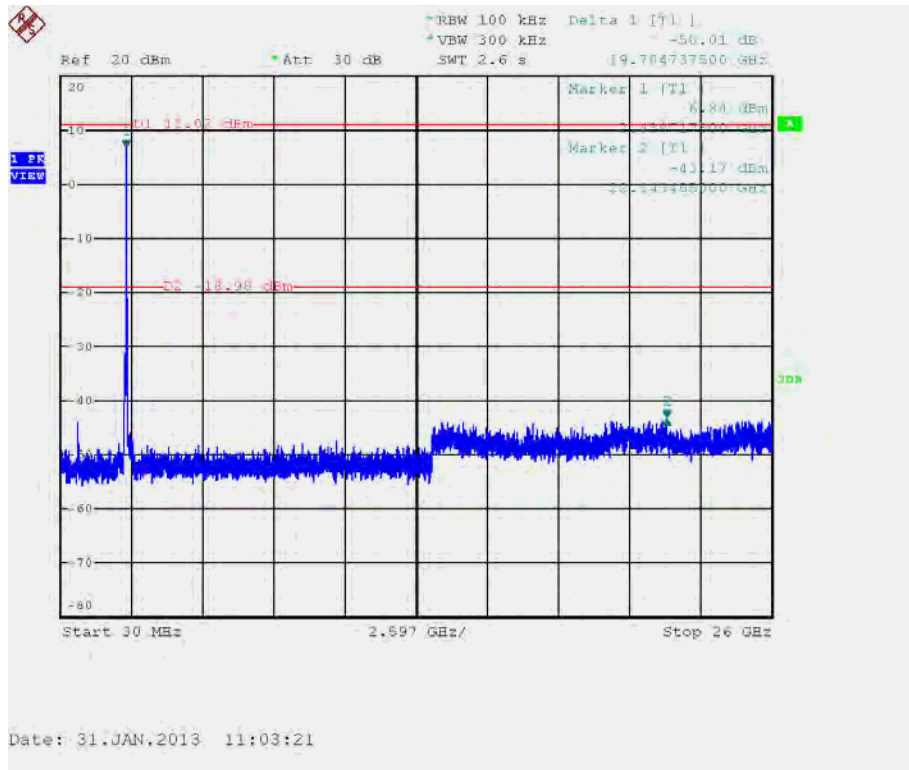

Plot on Configuration IEEE 802.11g / CH 11 (down 30dBc)

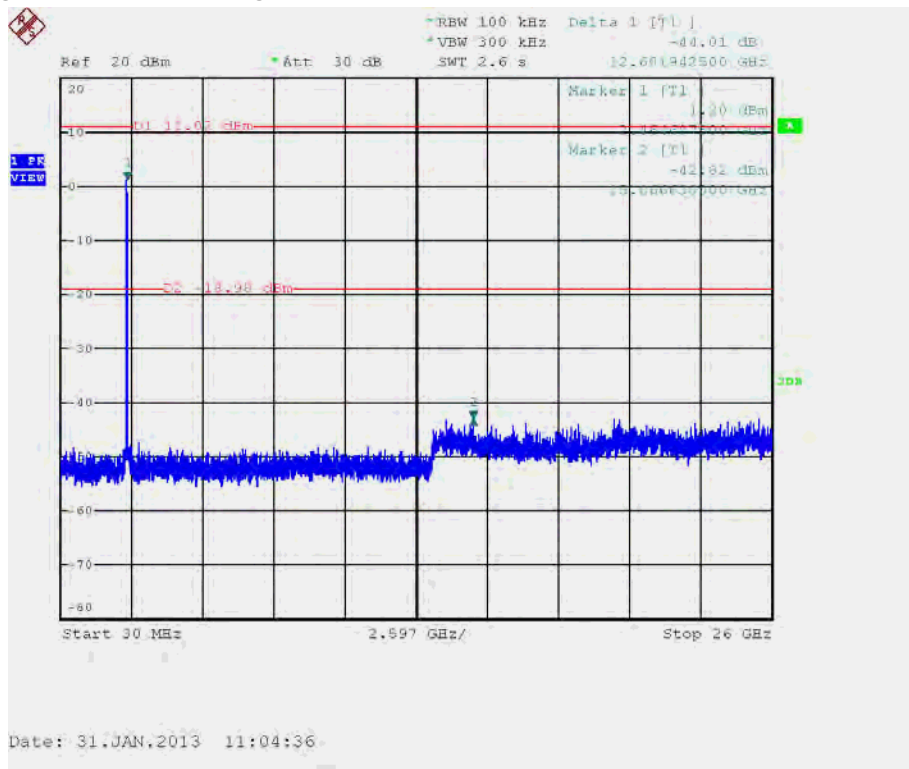

Plot on Configuration IEEE 802.11a / Reference Level

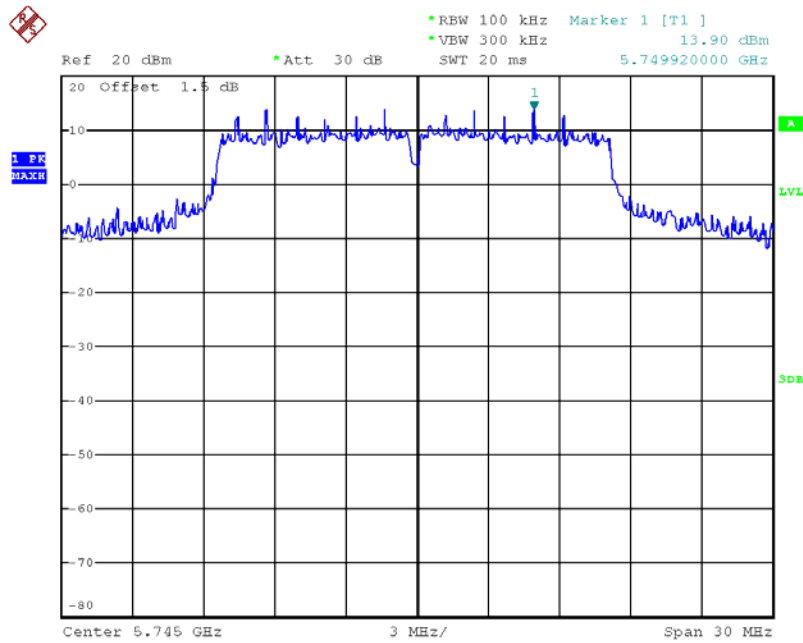

Date: 19.FEB.2013 13:26:17

Plot on Configuration IEEE 802.11a / CH 149 (down 30dBc)

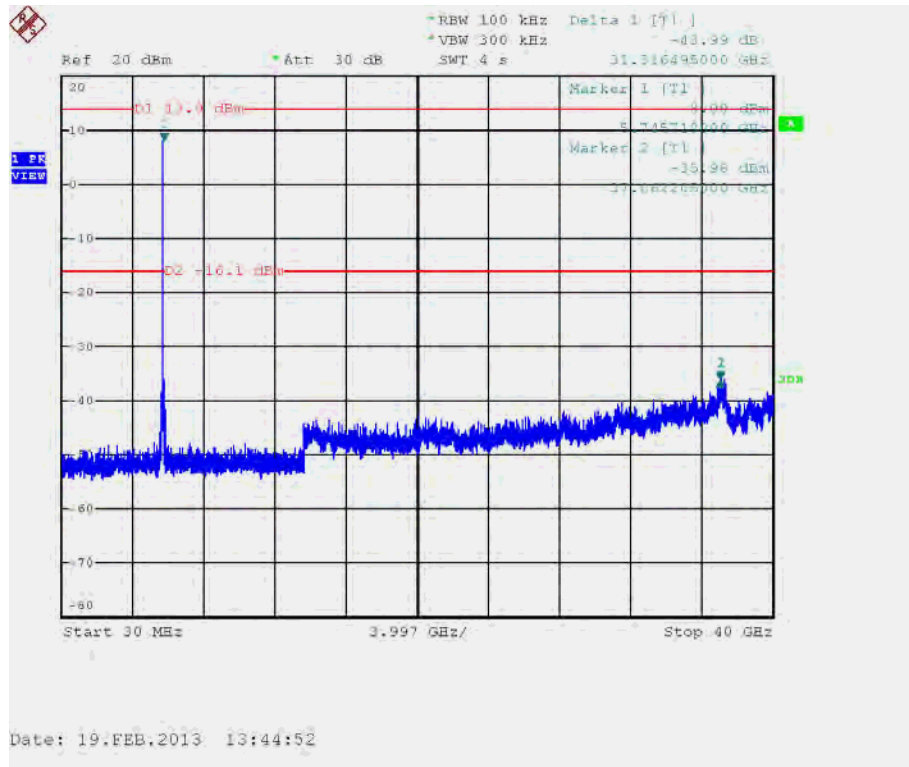

Plot on Configuration IEEE 802.11a / CH 157 (down 30dBc)

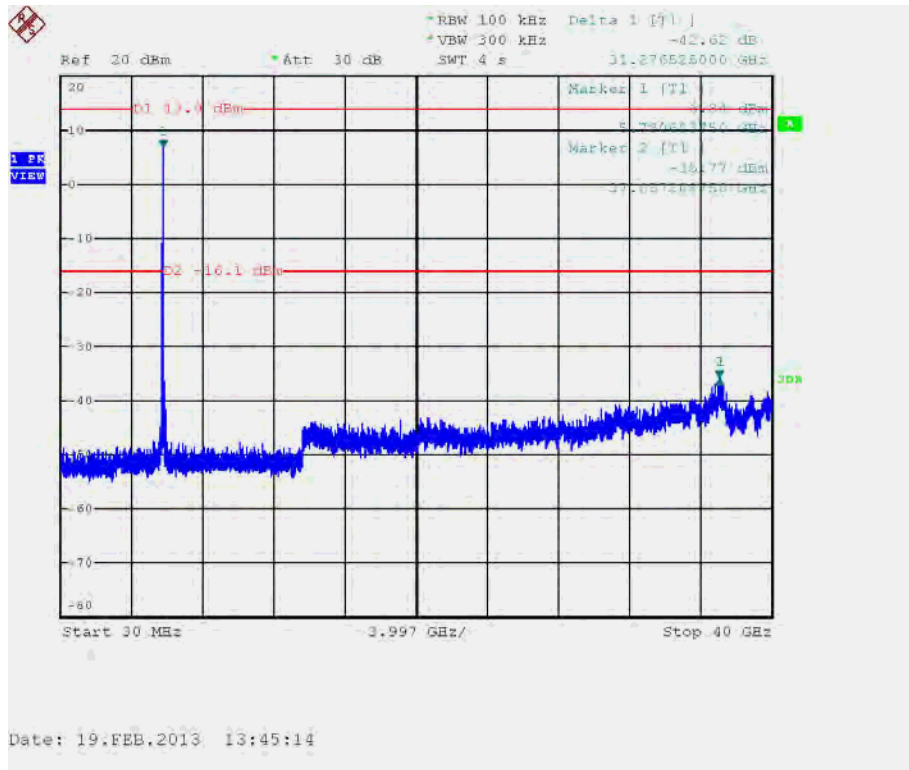

Plot on Configuration IEEE 802.11a / CH 165 (down 30dBc)

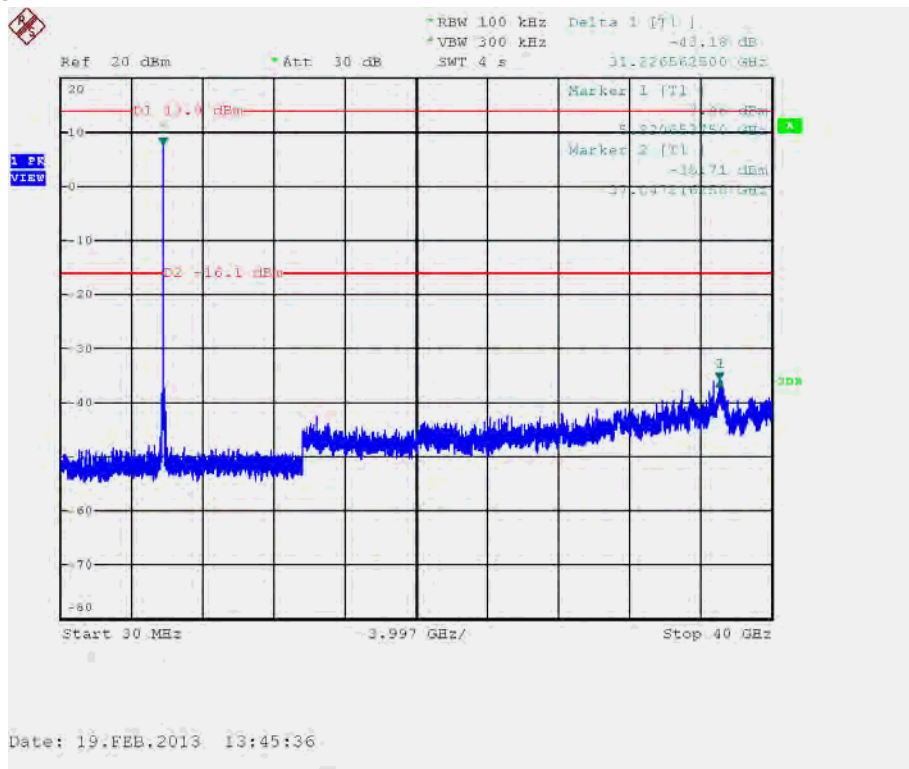

## 4.7. Antenna Requirements

### 4.7.1. Limit

Except for special regulations, the Low-power Radio-frequency Devices must not be equipped with any jacket for installing an antenna with extension cable. An intentional radiator shall be designed to ensure that no antenna other than that furnished by the responsible party shall be used with the device. The use of a permanently attached antenna or of an antenna that uses a unique coupling to the intentional radiator shall be considered sufficient to comply with the provisions of this Section. The manufacturer may design the unit so that the user can replace a broken antenna, but the use of a standard antenna jack or electrical connector is prohibited. Further, this requirement does not apply to intentional radiators that must be professionally installed.

### 4.7.2. Antenna Connector Construction

Please refer to section 3.3 in this test report; antenna connector complied with the requirements.

## 5. LIST OF MEASURING EQUIPMENTS

Instrument	Manufacturer	Model No.	Serial No.	Characteristics	Calibration Date	Remark
EMI Test Receiver	R&S	ESCS 30	100377	9kHz ~ 2.75GHz	Oct. 23, 2012	Conduction (CO01-CB)
LISN	F.C.C.	FCC-LISN-50-16-2	04083	150kHz ~ 100MHz	Nov.26, 2012	Conduction (CO01-CB)
V- LISN	Schwarzbeck	NSLK 8127	8127-478	9kHz ~ 30MHz	Jun. 22, 2012	Conduction (CO01-CB)
Coupling Decoupling Network	TESEQ	ST08	24348	150kHz ~ 230MHz	Dec. 03, 2012	Conduction (CO01-CB)
COND Cable	Woken	Cable	01	0.15MHz-30MHz	Dec. 4, 2012	Conduction (CO01-CB)
Software	Audix	E3	5.410e	-	-	Conduction (CO01-CB)
BILOG ANTENNA	Schaffner	CBL6112D	22021	20MHz ~ 2GHz	Jan. 11, 2013	Radiation (03CH01-CB)
Loop Antenna	Teseq	HLA 6120	24155	9 kHz - 30 MHz	Nov. 05, 2012*	Radiation (03CH01-CB)
forHorn Antenna	EMCO	3115	00075790	750MHz-18GHz	Nov. 27, 2012	Radiation (03CH01-CB)
Horn Antenna	SCHWARZBEAK	BBHA 9170	BBHA9170252	15GHz ~ 40GHz	Nov. 23, 2012	Radiation (03CH01-CB)
Pre-Amplifier	Agilent	8447D	2944A10991	0.1MHz ~ 1.3GHz	Nov. 27, 2012	Radiation (03CH01-CB)
Pre-Amplifier	Agilent	8449B	3008A02310	1GHz ~ 26.5GHz	Nov. 23, 2012	Radiation (03CH01-CB)
Pre-Amplifier	WM	TF-130N-R1	923365	26.5GHz ~ 40GHz	Jul. 31, 2012	Radiation (03CH01-CB)
Spectrum analyzer	R&S	FSP40	100056	9KHz-40GHz	Nov. 16, 2012	Radiation (03CH01-CB)
EMI Test Receiver	R&S	ESCS 30	100355	9KHz ~ 2.75GHz	Mar. 20, 2012	Radiation (03CH01-CB)
Turn Table	INN CO	CO 2000	N/A	0 ~ 360 degree	N.C.R	Radiation (03CH01-CB)
Antenna Mast	INN CO	CO2000	N/A	1 m - 4 m	N.C.R	Radiation (03CH01-CB)
RF Cable-low	Woken	Low Cable-1	N/A	30 MHz - 1 GHz	Nov. 18, 2012	Radiation (03CH01-CB)
RF Cable-high	Woken	High Cable-1	N/A	1 GHz ~ 26.5 GHz	Nov. 18, 2012	Radiation (03CH01-CB)
RF Cable-high	Woken	High Cable-2	N/A	1 GHz ~ 26.5 GHz	Nov. 18, 2012	Radiation (03CH01-CB)
RF Cable-high	Woken	High Cable-3	N/A	1 GHz - 40 GHz	Nov. 18, 2012	Radiation (03CH01-CB)
RF Cable-high	Woken	High Cable-4	N/A	1 GHz - 40 GHz	Nov. 18, 2012	Radiation (03CH01-CB)
Signal analyzer	R&S	FSV40	100979	9KHz-40GHz	Oct. 08, 2012	Conducted (TH01-CB)

Instrument	Manufacturer	Model No.	Serial No.	Characteristics	Calibration Date	Remark
Temp. and Humidity Chamber	Ten Billion	TTH-D3SP	TBN-931011	-30-100 degree	Jun. 05, 2012	Conducted (TH01-CB)
RF Power Divider	Woken	2 Way	0120A02056002D	2GHz - 18GHz	Nov. 18, 2012	Conducted (TH01-CB)
RF Power Divider	Woken	3 Way	MDC2366	2GHz - 18GHz	Nov. 18, 2012	Conducted (TH01-CB)
RF Power Divider	Woken	4 Way	0120A04056002D	2GHz - 18GHz	Nov. 18, 2012	Conducted (TH01-CB)
RF Cable-high	Woken	High Cable-7	-	1 GHz - 26.5 GHz	Nov. 19, 2012	Conducted (TH01-CB)
RF Cable-high	Woken	High Cable-8	-	1 GHz - 26.5 GHz	Nov. 19, 2012	Conducted (TH01-CB)
RF Cable-high	Woken	High Cable-9	-	1 GHz - 26.5 GHz	Nov. 19, 2012	Conducted (TH01-CB)
RF Cable-high	Woken	High Cable-10	-	1 GHz - 26.5 GHz	Nov. 19, 2012	Conducted (TH01-CB)
RF Cable-high	Woken	High Cable-11	-	1 GHz - 26.5 GHz	Nov. 19, 2012	Conducted (TH01-CB)
Power Sensor	Anritsu	MA2411B	0917223	300MHz-40GHz	Nov. 28, 2012	Conducted (TH01-CB)
Power Meter	Anritsu	ML2495A	1035008	300MHz-40GHz	Nov. 27, 2012	Conducted (TH01-CB)

Note: Calibration Interval of instruments listed above is one year.

“\*” Calibration Interval of instruments listed above is two years.

N.C.R. means Non-Calibration required.

## 6. TEST LOCATION

SHIJR	ADD : 6Fl., No. 106, Sec. 1, Shintai 5th Rd., Shijr City, Taipei, Taiwan 221, R.O.C. TEL : 886-2-2696-2468 FAX : 886-2-2696-2255
HWA YA	ADD : No. 52, Hwa Ya 1st Rd., Kwei-Shan Hsiang, Tao Yuan Hsien, Taiwan, R.O.C. TEL : 886-3-327-3456 FAX : 886-3-318-0055
LINKOU	ADD : No. 30-2, Dingfu Tsuen, Linkou Shiang, Taipei, Taiwan 244, R.O.C TEL : 886-2-2601-1640 FAX : 886-2-2601-1695
DUNGHU	ADD : No. 3, Lane 238, Kangle St., Neihu Chiu, Taipei, Taiwan 114, R.O.C. TEL : 886-2-2631-4739 FAX : 886-2-2631-9740
JUNGHE	ADD : 7Fl., No. 758, Jungjeng Rd., Junghe City, Taipei, Taiwan 235, R.O.C. TEL : 886-2-8227-2020 FAX : 886-2-8227-2626
NEIHU	ADD : 4Fl., No. 339, Hsin Hu 2 <sup>nd</sup> Rd., Taipei 114, Taiwan, R.O.C. TEL : 886-2-2794-8886 FAX : 886-2-2794-9777
JHUBEI	ADD : No.8, Lane 724, Bo-ai St., Jhubei City, HsinChu County 302, Taiwan, R.O.C. TEL : 886-3-656-9065 FAX : 886-3-656-9085