



# SPORTON International Inc.

No. 52, Hwa Ya 1st Rd., Kwei-Shan Hsiang, TaoYuan Hsien, Taiwan, R.O.C.  
Ph: 886-3-327-3456 / FAX: 886-3-327-0973 / www.sporton.com.tw

## FCC RADIO TEST REPORT

Applicant's company	NETGEAR, Inc.
Applicant Address	350 East Plumeria Drive, San Jose, CA 95134, USA
FCC ID	PY312200204
Manufacturer's company	Ambit Microsystems (Shanghai) Ltd.
Manufacturer Address	No. 1925, Nanle Road, Songjiang Export Processing Zone, Shanghai, China

Product Name	Mobile LTE Broadband 11n Wireless Router
Brand Name	NETGEAR
Model Name	MBR1516
Test Rule	47 CFR FCC Part 15 Subpart C § 15.247
Test Freq. Range	2400 ~ 2483.5MHz
Received Date	Aug. 29, 2012
Final Test Date	Sep. 05, 2012
Submission Type	Original Equipment

### Statement

Test result included in this report is for the IEEE 802.11n and IEEE 802.11b/g part of the product.

The test result in this report refers exclusively to the presented test model / sample.

Without written approval of SPORTON International Inc., the test report shall not be reproduced except in full.

The measurements and test results shown in this test report were made in accordance with the procedures and found in compliance with the limit given in **ANSI C63.10-2009** and **47 CFR FCC Part 15 Subpart C** and KDB558074 - 20120118 & KDB662911 D01-20110404.

The test equipment used to perform the test is calibrated and traceable to NML/ROC.



## Table of Contents

<b>1. CERTIFICATE OF COMPLIANCE</b> .....	<b>1</b>
<b>2. SUMMARY OF THE TEST RESULT</b> .....	<b>2</b>
<b>3. GENERAL INFORMATION</b> .....	<b>3</b>
3.1. Product Details .....	3
3.2. Accessories .....	5
3.3. Table for Filed Antenna .....	5
3.4. Table for Carrier Frequencies .....	6
3.5. Table for Test Modes .....	6
3.6. Table for Testing Locations.....	7
3.7. Table for Supporting Units .....	7
3.8. Table for Parameters of Test Software Setting .....	8
3.9. Test Configurations.....	9
<b>4. TEST RESULT</b> .....	<b>11</b>
4.1. AC Power Line Conducted Emissions Measurement .....	11
4.2. Peak Output Power Measurement .....	17
4.3. Average Output Power Measurement.....	20
4.4. Power Spectral Density Measurement.....	23
4.5. 6dB Spectrum Bandwidth Measurement .....	31
4.6. Radiated Emissions Measurement.....	36
4.7. Band Edge Emissions Measurement.....	56
4.8. Antenna Requirements .....	69
<b>5. LIST OF MEASURING EQUIPMENTS</b> .....	<b>70</b>
<b>6. TEST LOCATION</b> .....	<b>72</b>
<b>7. TAF CERTIFICATE OF ACCREDITATION</b> .....	<b>73</b>
<b>APPENDIX A. TEST PHOTOS</b> .....	<b>A1 ~ A7</b>
<b>APPENDIX B. MAXIMUM PERMISSIBLE EXPOSURE</b> .....	<b>B1 ~ B3</b>
<b>APPENDIX C. CO-LOCATION REPORT</b> .....	<b>C1 ~ C5</b>

### History of This Test Report

REPORT NO.	VERSION	DESCRIPTION	ISSUED DATE
FR290428	Rev. 01	Initial issue of report	Sep. 07, 2012



## 1. CERTIFICATE OF COMPLIANCE

**Product Name** : Mobile LTE Broadband 11n Wireless Router  
**Brand Name** : NETGEAR  
**Model Name** : MBR1516  
**Applicant** : NETGEAR, Inc.  
**Test Rule Part(s)** : 47 CFR FCC Part 15 Subpart C § 15.247

Sporton International as requested by the applicant to evaluate the EMC performance of the product sample received on Aug. 29, 2012 would like to declare that the tested sample has been evaluated and found to be in compliance with the tested rule parts. The data recorded as well as the test configuration specified is true and accurate for showing the sample's EMC nature.

A handwritten signature in blue ink that reads "Jordan Hsiao" is written over a horizontal line.

**Jordan Hsiao**

**SPORTON INTERNATIONAL INC.**

## 2. SUMMARY OF THE TEST RESULT

Applied Standard: 47 CFR FCC Part 15 Subpart C				
Part	Rule Section	Description of Test	Result	Under Limit
4.1	15.207	AC Power Line Conducted Emissions	Complies	10.69 dB
4.2	15.247(b)(3)	Peak Output Power	Complies	0.58 dB
4.3	15.247(e)	Power Spectral Density	Complies	7.10 dB
4.4	15.247(a)(2)	6dB Spectrum Bandwidth	Complies	-
4.5	15.247(d)	Radiated Emissions	Complies	3.08 dB
4.6	15.247(d)	Band Edge Emissions	Complies	0.18 dB
4.7	15.203	Antenna Requirements	Complies	-

Note: The EUT contains LTE transmitter module FCC ID: N7NMC7700.

Test Items	Uncertainty	Remark
AC Power Line Conducted Emissions	±2.3dB	Confidence levels of 95%
Peak Output Power	±0.8dB	Confidence levels of 95%
Power Spectral Density	±0.5dB	Confidence levels of 95%
6dB Spectrum Bandwidth	±8.5×10 <sup>-8</sup>	Confidence levels of 95%
Radiated Emissions (9kHz~30MHz)	±0.8dB	Confidence levels of 95%
Radiated Emissions (30MHz~1GHz)	±1.9dB	Confidence levels of 95%
Radiated / Band Edge Emissions (1GHz~18GHz)	±1.9dB	Confidence levels of 95%
Radiated Emissions (18GHz~40GHz)	±1.9dB	Confidence levels of 95%
Temperature	±0.7°C	Confidence levels of 95%
Humidity	±3.2%	Confidence levels of 95%
DC / AC Power Source	±1.4%	Confidence levels of 95%

### 3. GENERAL INFORMATION

#### 3.1. Product Details

##### IEEE 802.11n

Items	Description
Product Type	WLAN (2TX, 2RX)
Radio Type	Intentional Transceiver
Power Type	From Power Adapter
Modulation	see the below table for IEEE 802.11n
Data Modulation	OFDM (BPSK / QPSK / 16QAM / 64QAM)
Data Rate (Mbps)	see the below table for IEEE 802.11n
Frequency Range	2400 ~ 2483.5MHz
Channel Number	11 for 20MHz bandwidth ; 7 for 40MHz bandwidth
Channel Band Width (99%)	MCS0 (20MHz): 28.48MHz ; MCS0 (40MHz): 36.72 MHz
Peak Output Power	MCS0 (20MHz): 29.40 dBm ; MCS0 (40MHz): 27.88 dBm
Carrier Frequencies	Please refer to section 3.4
Antenna	Please refer to section 3.3

##### IEEE 802.11b/g

Items	Description
Product Type	802.11b: WLAN (1TX, 1RX) 802.11g: WLAN (2TX, 2RX)
Radio Type	Intentional Transceiver
Power Type	From Power Adapter
Modulation	DSSS for IEEE 802.11b ; OFDM for IEEE 802.11g
Data Modulation	DSSS (BPSK / QPSK / CCK) ; OFDM (BPSK / QPSK / 16QAM / 64QAM)
Data Rate (Mbps)	DSSS (1/ 2/ 5.5/11) ; OFDM (6/9/12/18/24/36/48/54)
Frequency Range	2400 ~ 2483.5MHz
Channel Number	11
Channel Band Width (99%)	11b: 14.48 MHz ; 11g: 26.08 MHz
Peak Output Power	11b: 26.19 dBm ; 11g: 29.42 dBm
Carrier Frequencies	Please refer to section 3.4
Antenna	Please refer to section 3.3

**Antenna & Band width**

Antenna	Single (TX)		Two (TX)	
Band width Mode	20 MHz	40 MHz	20 MHz	40 MHz
IEEE 802.11b	V	X	X	X
IEEE 802.11g	X	X	V	X
IEEE 802.11n	X	X	V	V

**IEEE 802.11n spec**

MCS Index	Nss	Modulation	R	NBPS	NCBPS		NDBPS		Datarate(Mbps)			
					20MHz	40MHz	20MHz	40MHz	800nsGI		400nsGI	
									20MHz	40MHz	20MHz	40MHz
0	1	BPSK	1/2	1	52	108	26	54	6.5	13.5	7.200	15
1	1	QPSK	1/2	2	104	216	52	108	13.0	27.0	14.400	30
2	1	QPSK	3/4	2	104	216	78	162	19.5	40.5	21.700	45
3	1	16-QAM	1/2	4	208	432	104	216	26.0	54.0	28.900	60
4	1	16-QAM	3/4	4	208	432	156	324	39.0	81.0	43.300	90
5	1	64-QAM	2/3	6	312	648	208	432	52.0	108.0	57.800	120
6	1	64-QAM	3/4	6	312	648	234	486	58.5	121.5	65.000	135
7	1	64-QAM	5/6	6	312	648	260	540	65.0	135.0	72.200	150
8	2	BPSK	1/2	1	104	216	52	108	13.0	27.0	14.444	30
9	2	QPSK	1/2	2	208	432	104	216	26.0	54.0	28.889	60
10	2	QPSK	3/4	2	208	432	156	324	39.0	81.0	43.333	90
11	2	16-QAM	1/2	4	416	864	208	432	52.0	108.0	57.778	120
12	2	16-QAM	3/4	4	416	864	312	648	78.0	162.0	86.667	180
13	2	64-QAM	2/3	6	624	1296	416	864	104.0	216.0	115.556	240
14	2	64-QAM	3/4	6	624	1296	468	972	117.0	243.0	130.000	270
15	2	64-QAM	5/6	6	624	1296	520	1080	130.0	270.0	144.444	300

Symbol	Explanation
NSS	Number of spatial streams
R	Code rate
NBPS	Number of coded bits per single carrier
NCBPS	Number of coded bits per symbol
NDBPS	Number of data bits per symbol
GI	guard interval

### 3.2. Accessories

Power	Brand	P/N	Model	Rating
Adapter 1	NETGEAR	332-10221-01	MT18-9120150-A1	Input: 120VAC, 60Hz, 0.5A Output: 12VDC, 1.5A
Adapter 2	NETGEAR	332-10114-01	AD661F	Input: 100-120VAC, 50/60Hz, 680mA Output: 12VDC, 1.5A
Others				
RJ-45 Cable, Non-shielded, 10m				
Cardle*1				

### 3.3. Table for Filed Antenna

Ant.	Brand	Model Name	Antenna Type	Connector	Gain (dBi)	Remark
1	-	-	Print Antenna	N/A	1.7	TX/RX
2	-	-	Print Antenna	N/A	2.5	TX/RX

Note: The EUT has two antennas.

**For IEEE 802.11b mode (1TX/1RX):**

Only Ant. 1 can be used as transmitting antenna and receiving antenna.

**For IEEE 802.11g/n mode (2TX/2RX):**

Ant. 1 and Ant. 2 will transmit/receive the same signal simultaneously.

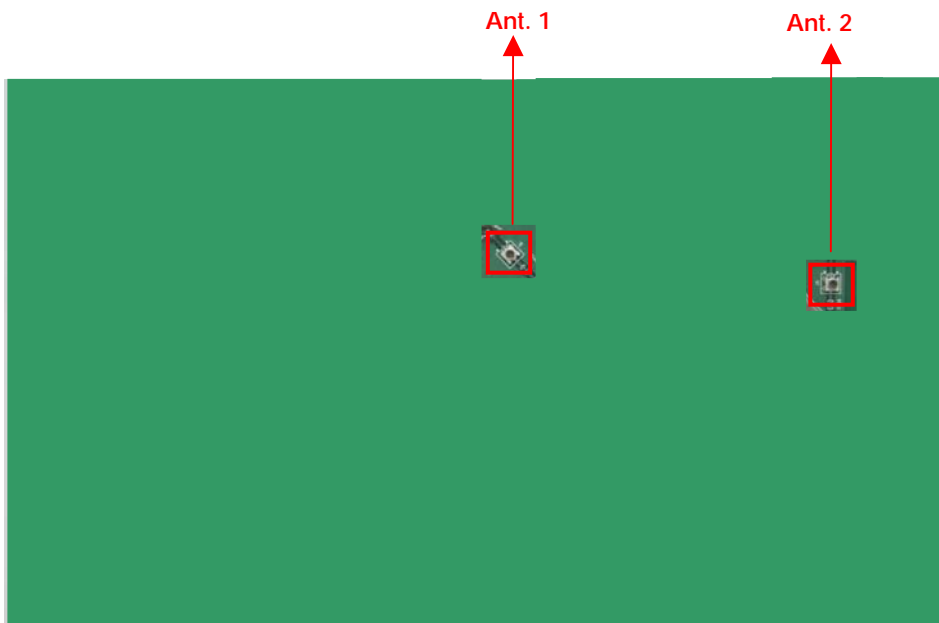



### 3.4. Table for Carrier Frequencies

For IEEE 802.11b/g, use Channel 1~Channel 11.

There are two bandwidth systems for IEEE 802.11n.

For both 20MHz bandwidth systems, use Channel 1~Channel 11.

For both 40MHz bandwidth systems, use Channel 3~Channel 9.

Frequency Band	Channel No.	Frequency	Channel No.	Frequency
2400~2483.5MHz	1	2412 MHz	7	2442 MHz
	2	2417 MHz	8	2447 MHz
	3	2422 MHz	9	2452 MHz
	4	2427 MHz	10	2457 MHz
	5	2432 MHz	11	2462 MHz
	6	2437 MHz	-	-

### 3.5. Table for Test Modes

Preliminary tests were performed in different data rate to find the worst radiated emission. The data rate shown in the table below is the worst-case rate with respect to the specific test item. Investigation has been done on all the possible configurations for searching the worst cases. The following table is a list of the test modes shown in this test report.

Test Items	Mode	Data Rate	Channel	Antenna
AC Power Line Conducted Emissions	CTX	-	-	-
Peak Output Power	MCS0/20MHz	6.5 Mbps	1/6/11	1/2/1+2
Average Output Power	MCS0/40MHz	13 Mbps	3/6/9	1/2/1+2
Power Spectral Density	11b/BPSK	1 Mbps	1/6/11	1
	11g/BPSK	6 Mbps	1/6/11	1/2/1+2
6dB Spectrum Bandwidth	MCS0/20MHz	6.5 Mbps	1/6/11	1+2
	MCS0/40MHz	13 Mbps	3/6/9	1+2
	11b/BPSK	1 Mbps	1/6/11	1
	11g/BPSK	6 Mbps	1/6/11	1+2
Radiated Emissions 9kHz~1GHz	CTX	-	-	-
Radiated Emissions 1GHz~10 <sup>th</sup>	MCS0/20MHz	6.5 Mbps	1/6/11	1+2
Harmonic	MCS0/40MHz	13 Mbps	3/6/9	1+2
	11b/BPSK	1 Mbps	1/6/11	1
	11g/BPSK	6 Mbps	1/6/11	1+2
Band Edge Emissions	MCS0/20MHz	6.5 Mbps	1/11	1+2
	MCS0/40MHz	13 Mbps	3/9	1+2
	11b/BPSK	1 Mbps	1/11	1
	11g/BPSK	6 Mbps	1/11	1+2

The following test modes were performed for all tests:

The EUT was performed at 3-axis and the worst-case was found at X axis.

So the measurement will follow this same mode.

**For Conducted Emission test:**

Mode 1. EUT + Adapter 1

Mode 2. EUT + Adapter 2

All test results were recorded in the report.

**For Radiated Emission test:**

Mode 1. EUT + Adapter 1

Mode 2. EUT + Adapter 2

For Radiated Emission test below 1GHz:

All test results were recorded in the report.

For Radiated Emission test above 1GHz:

Mode 1 performed as worse case, it was recorded in this report

### 3.6. Table for Testing Locations

Test Site No.	Site Category	Location	FCC Reg. No.	IC File No.
03CH01-CB	SAC	Hsin Chu	262045	IC 4086D
CO01-CB	Conduction	Hsin Chu	262045	IC 4086D
TH01-CB	OVEN Room	Hsin Chu	-	-

Open Area Test Site (OATS); Semi Anechoic Chamber (SAC)

Please refer section 6 for Test Site Address.

### 3.7. Table for Supporting Units

Support Unit	Brand	Model	FCC ID
Notebook	DELL	M1330	E2K4965AGNM

### 3.8. Table for Parameters of Test Software Setting

During testing, Channel & Power Controlling Software provided by the customer was used to control the operating channel as well as the output power level. The RF output power selection is for the setting of RF output power expected by the customer and is going to be fixed on the firmware of the final end product.

#### Power Parameters of IEEE 802.11n

Test Software Version	DOS		
Frequency	2412 MHz	2437 MHz	2462 MHz
MCS0 20MHz	61/80	25/31	82/83
Frequency	2422 MHz	2437 MHz	2452 MHz
MCS0 40MHz	61/75	64/76	82/86

#### Power Parameters of IEEE 802.11b/g

Test Software Version	DOS		
Frequency	2412 MHz	2437 MHz	2462 MHz
IEEE 802.11b	80	84	80
IEEE 802.11g	54/74	30/36	75/78

During the test, "DOS" under WIN XP was executed the test program to control the EUT continuously transmit RF signal.

### 3.9. Test Configurations

#### 3.9.1. Radiation Emissions Test Configuration

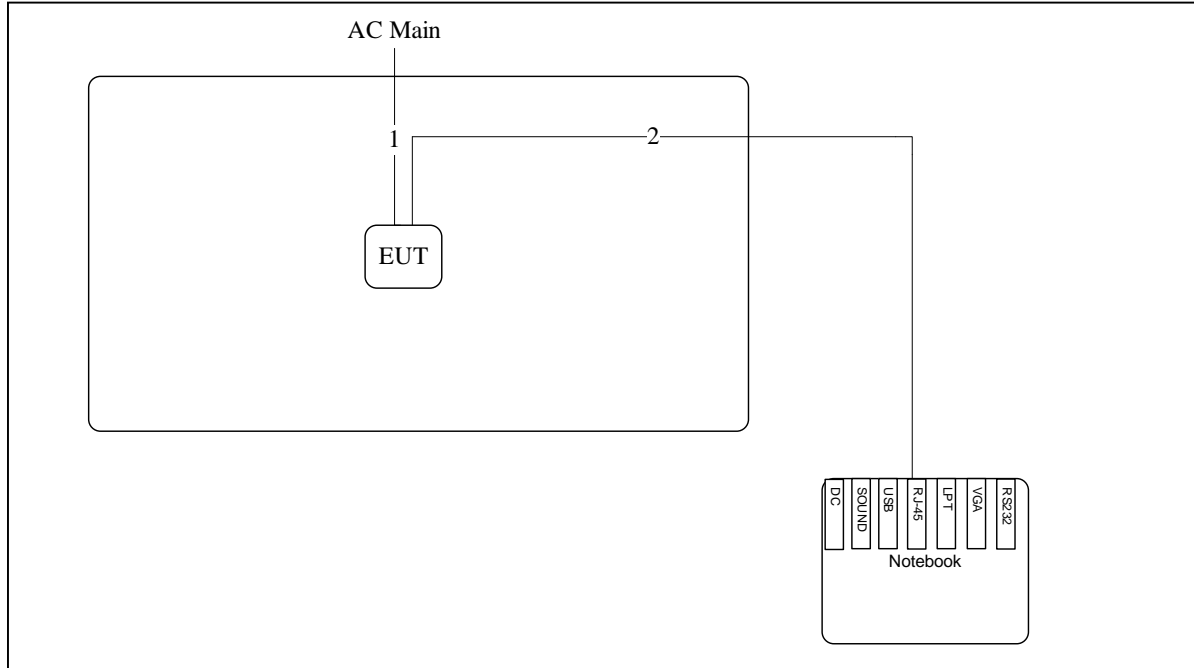

Item	Connection	Shield	Length
1	Power cable	No	1.7m
2	RJ-45 cable	No	10m

### 3.9.2. AC Power Line Conduction Emissions Test Configuration

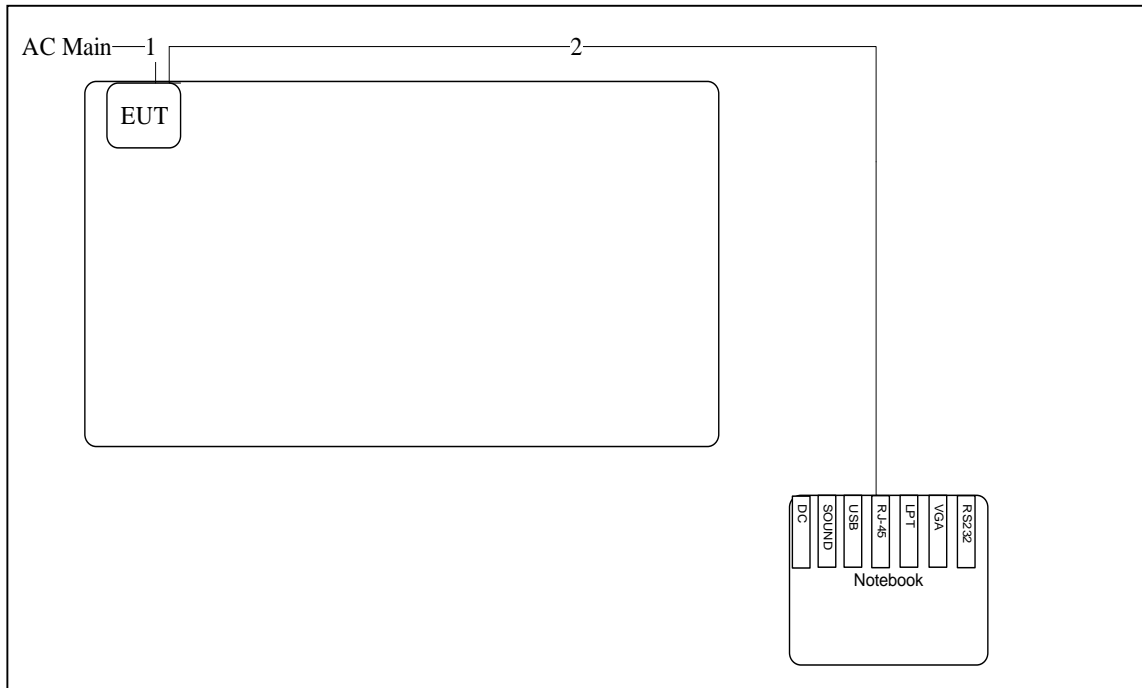

Item	Connection	Shield	Length
1	Power cable	No	1.7m
2	RJ-45 cable	No	10m

## 4. TEST RESULT

### 4.1. AC Power Line Conducted Emissions Measurement

#### 4.1.1. Limit

For this product which is designed to be connected to the AC power line, the radio frequency voltage that is conducted back onto the AC power line on any frequency or frequencies within the band 150 kHz to 30 MHz shall not exceed below limits table.

Frequency (MHz)	QP Limit (dBuV)	AV Limit (dBuV)
0.15~0.5	66~56	56~46
0.5~5	56	46
5~30	60	50

#### 4.1.2. Measuring Instruments and Setting

Please refer to section 5 of equipments list in this report. The following table is the setting of the receiver.

Receiver Parameters	Setting
Attenuation	10 dB
Start Frequency	0.15 MHz
Stop Frequency	30 MHz
IF Bandwidth	9 KHz

#### 4.1.3. Test Procedures

1. Configure the EUT according to ANSI C63.10. The EUT or host of EUT has to be placed 0.4 meter far from the conducting wall of the shielding room and at least 80 centimeters from any other grounded conducting surface.
2. Connect EUT or host of EUT to the power mains through a line impedance stabilization network (LISN).
3. All the support units are connected to the other LISNs. The LISN should provide 50uH/50ohms coupling impedance.
4. The frequency range from 150 KHz to 30 MHz was searched.
5. Set the test-receiver system to Peak Detect Function and Specified Bandwidth with Maximum Hold Mode.
6. The measurement has to be done between each power line and ground at the power terminal.

#### 4.1.4. Test Setup Layout

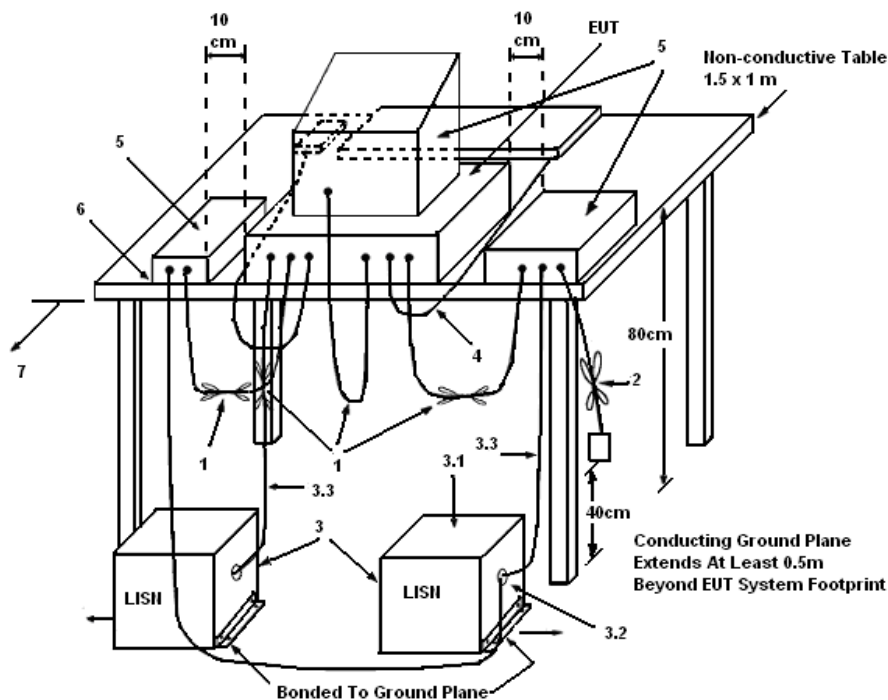

#### LEGEND:

- (1) Interconnecting cables that hang closer than 40 cm to the ground plane shall be folded back and forth in the center forming a bundle 30 to 40 cm long.
- (2) I/O cables that are not connected to a peripheral shall be bundled in the center. The end of the cable may be terminated, if required, using the correct terminating impedance. The overall length shall not exceed 1 m.
- (3) EUT connected to one LISN. Unused LISN measuring port connectors shall be terminated in 50  $\Omega$ . LISN can be placed on top of, or immediately beneath, reference ground plane.
  - (3.1) All other equipment powered from additional LISN(s).
  - (3.2) Multiple outlet strip can be used for multiple power cords of non-EUT equipment.
  - (3.3) LISN at least 80 cm from nearest part of EUT chassis.
- (4) Cables of hand-operated devices, such as keyboards, mice, etc., shall be placed as for normal use.
- (5) Non-EUT components of EUT system being tested.
- (6) Rear of EUT, including peripherals, shall all be aligned and flush with rear of tabletop.
- (7) Rear of tabletop shall be 40 cm removed from a vertical conducting plane that is bonded to the ground plane.

#### 4.1.5. Test Deviation

There is no deviation with the original standard.

#### 4.1.6. EUT Operation during Test

The EUT was placed on the test table and programmed in normal function.

4.1.7. Results of AC Power Line Conducted Emissions Measurement

Temperature	23°C	Humidity	54.2%
Test Engineer	Ryo Fan	Phase	Line
Configuration	Normal Link	Test Mode	Mode 1

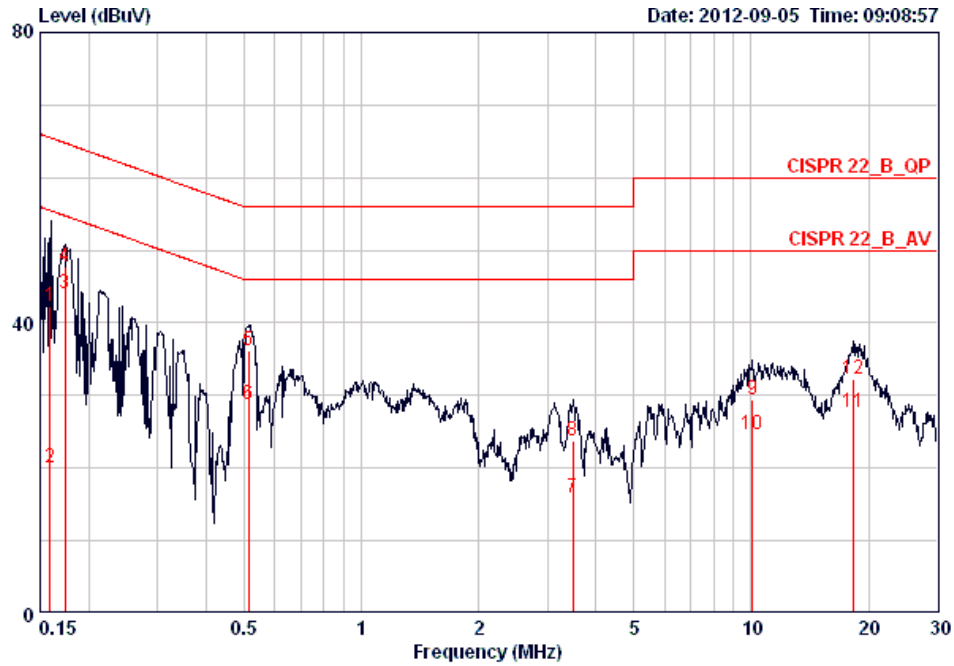

	Freq	Level	Over Limit	Limit Line	Read Level	LISN Factor	Cable Loss	Pol/Phase	Remark
	MHz	dBuV	dB	dBuV	dBuV	dB	dB		
1	0.15910	42.26	-23.25	65.51	41.90	0.16	0.20	LINE	QP
2	0.15910	20.12	-35.39	55.51	19.76	0.16	0.20	LINE	AVERAGE
3	0.17399	44.08	-10.69	54.77	43.73	0.15	0.20	LINE	AVERAGE
4	0.17399	47.83	-16.94	64.77	47.48	0.15	0.20	LINE	QP
5	0.51278	36.24	-19.76	56.00	35.89	0.15	0.20	LINE	QP
6	0.51278	28.72	-17.28	46.00	28.37	0.15	0.20	LINE	AVERAGE
7	3.491	15.81	-30.19	46.00	15.30	0.21	0.30	LINE	AVERAGE
8	3.491	23.69	-32.31	56.00	23.18	0.21	0.30	LINE	QP
9	10.072	29.49	-30.51	60.00	28.83	0.34	0.31	LINE	QP
10	10.072	24.63	-25.37	50.00	23.97	0.34	0.31	LINE	AVERAGE
11	18.328	27.69	-22.31	50.00	26.73	0.46	0.50	LINE	AVERAGE
12	18.328	32.25	-27.75	60.00	31.29	0.46	0.50	LINE	QP



Temperature	23°C	Humidity	54.2%
Test Engineer	Ryo Fan	Phase	Neutral
Configuration	Normal Link	Test Mode	Mode 1

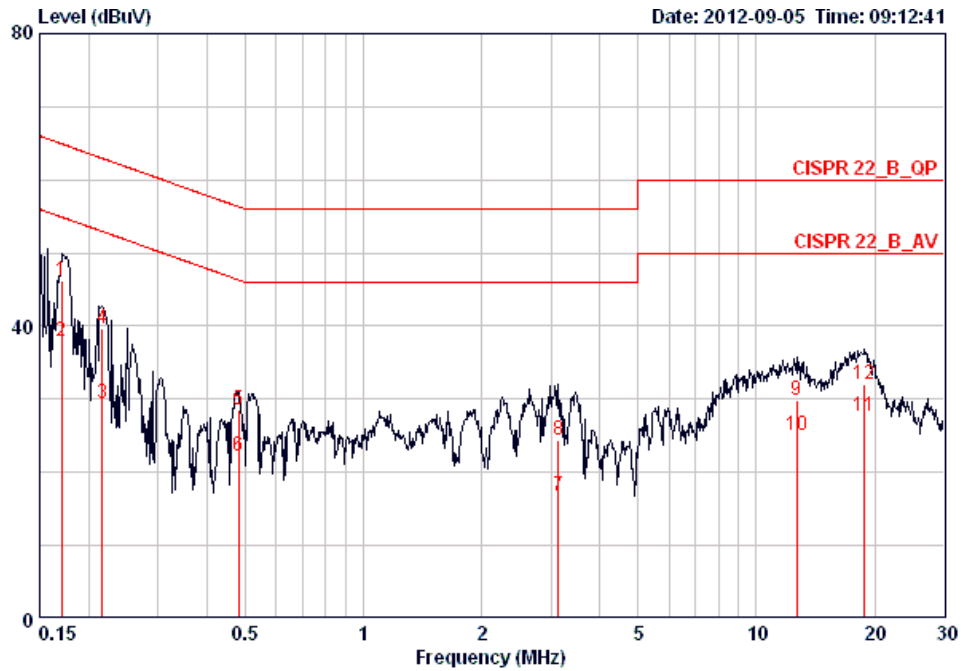

	Freq	Level	Limit	Line	ead	LISN	Cable		
	MHz	dBuV	dB	dBuV	Level	Factor	Loss	Pol/Phase	Remark
					dBuV	dB	dB		
1	0.17034	46.16	-18.78	64.94	45.88	0.08	0.20	NEUTRAL	QP
2	0.17034	37.86	-17.08	54.94	37.58	0.08	0.20	NEUTRAL	AVERAGE
3	0.21620	29.44	-23.52	52.96	29.16	0.08	0.20	NEUTRAL	AVERAGE
4	0.21620	39.62	-23.34	62.96	39.34	0.08	0.20	NEUTRAL	QP
5	0.48119	28.52	-27.80	56.32	28.34	0.08	0.10	NEUTRAL	QP
6	0.48119	22.15	-24.17	46.32	21.97	0.08	0.10	NEUTRAL	AVERAGE
7	3.140	16.81	-29.19	46.00	16.46	0.12	0.23	NEUTRAL	AVERAGE
8	3.140	24.44	-31.56	56.00	24.09	0.12	0.23	NEUTRAL	QP
9	12.649	29.81	-30.19	60.00	29.13	0.28	0.40	NEUTRAL	QP
10	12.649	25.11	-24.89	50.00	24.43	0.28	0.40	NEUTRAL	AVERAGE
11	18.820	27.76	-22.24	50.00	26.89	0.37	0.50	NEUTRAL	AVERAGE
12	18.820	32.11	-27.89	60.00	31.24	0.37	0.50	NEUTRAL	QP

Note:

Level = Read Level + LISN Factor + Cable Loss.

Temperature	23°C	Humidity	54.2%
Test Engineer	Ryo Fan	Phase	Line
Configuration	Normal Link	Test Mode	Mode 2

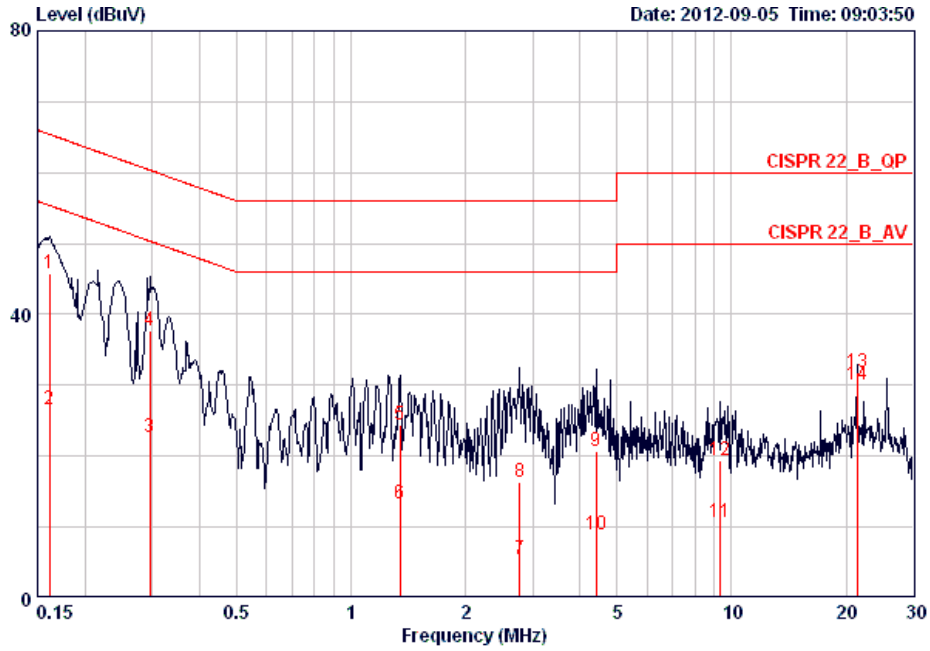

	Freq	Level	Over	Limit	Read	LISN	Cable		Remark
	MHz	dBuV	Limit	Line	Level	Factor	Loss	Pol/Phase	
			dB	dBuV	dBuV	dB	dB		
1	0.16155	45.78	-19.60	65.38	45.42	0.16	0.20	LINE	QP
2	0.16155	26.65	-28.73	55.38	26.29	0.16	0.20	LINE	AVERAGE
3	0.29555	22.71	-27.66	50.37	22.36	0.15	0.20	LINE	AVERAGE
4	0.29555	37.82	-22.55	60.37	37.47	0.15	0.20	LINE	QP
5	1.345	24.46	-31.54	56.00	24.15	0.18	0.13	LINE	QP
6	1.345	13.31	-32.69	46.00	13.00	0.18	0.13	LINE	AVERAGE
7	2.779	5.52	-40.48	46.00	5.12	0.20	0.20	LINE	AVERAGE
8	2.779	16.45	-39.55	56.00	16.05	0.20	0.20	LINE	QP
9	4.407	20.78	-35.22	56.00	20.25	0.23	0.30	LINE	QP
10	4.407	9.02	-36.98	46.00	8.49	0.23	0.30	LINE	AVERAGE
11	9.302	10.77	-39.23	50.00	10.14	0.33	0.30	LINE	AVERAGE
12	9.302	19.43	-40.57	60.00	18.80	0.33	0.30	LINE	QP
13	21.331	31.75	-28.25	60.00	30.74	0.51	0.50	LINE	QP
14	21.331	30.05	-19.95	50.00	29.04	0.51	0.50	LINE	AVERAGE

Temperature	23°C	Humidity	54.2%
Test Engineer	Ryo Fan	Phase	Neutral
Configuration	Normal Link	Test Mode	Mode 2

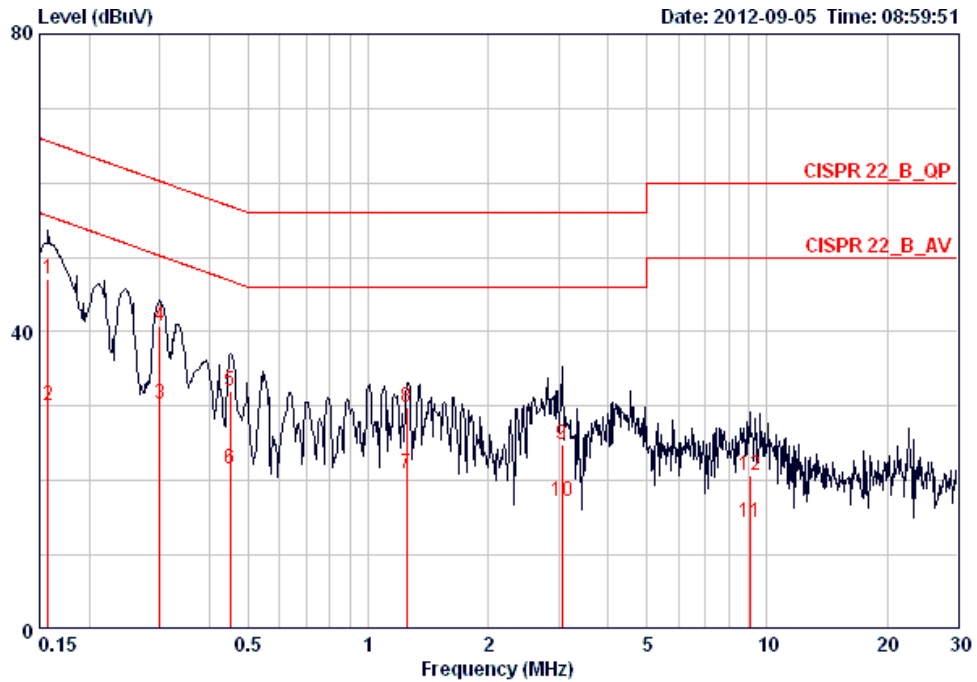

	Freq	Level	Over Limit	Limit Line	Read Level	LISN Factor	Cable Loss	Pol/Phase	Remark
	MHz	dBuV	dB	dBuV	dBuV	dB	dB		
1	0.15733	47.18	-18.42	65.60	46.90	0.08	0.20	NEUTRAL	QP
2	0.15733	30.00	-25.60	55.60	29.72	0.08	0.20	NEUTRAL	AVERAGE
3	0.30028	30.39	-19.85	50.24	30.11	0.08	0.20	NEUTRAL	AVERAGE
4	0.30028	40.73	-19.51	60.24	40.45	0.08	0.20	NEUTRAL	QP
5	0.45155	31.94	-24.91	56.85	31.66	0.08	0.20	NEUTRAL	QP
6	0.45155	21.65	-25.20	46.85	21.37	0.08	0.20	NEUTRAL	AVERAGE
7	1.249	20.88	-25.12	46.00	20.64	0.09	0.15	NEUTRAL	AVERAGE
8	1.249	29.92	-26.08	56.00	29.68	0.09	0.15	NEUTRAL	QP
9	3.058	24.95	-31.05	56.00	24.62	0.12	0.21	NEUTRAL	QP
10	3.058	17.11	-28.89	46.00	16.78	0.12	0.21	NEUTRAL	AVERAGE
11	9.059	14.35	-35.65	50.00	13.83	0.22	0.30	NEUTRAL	AVERAGE
12	9.059	20.65	-39.35	60.00	20.13	0.22	0.30	NEUTRAL	QP

Note:

Level = Read Level + LISN Factor + Cable Loss.

## 4.2. Peak Output Power Measurement

### 4.2.1. Limit

For systems using digital modulation in the 2400-2483.5MHz, the limit for peak output power is 30dBm. The limited has to be reduced by the amount in dB that the gain of the antenna exceed 6dBi. In case of point-to-point operation, the limit has to be reduced by 1dB for every 3dB that the directional gain of the antenna exceeds 6dBi.

### 4.2.2. Measuring Instruments and Setting

Please refer to section 5 of equipments list in this report. The following table is the setting of the peak power meter.

Power Meter Parameter	Setting
Bandwidth	50MHz bandwidth is greater than the EUT emission bandwidth
Detector	Peak

### 4.2.3. Test Procedures

Spectrum Parameter	Setting
RF Output Power Method	<input checked="" type="checkbox"/> ANSI C63.10 clause 6.10.2.1 (a) power meter method
RF Output Power Method	<input type="checkbox"/> ANSI C63.10 clause 6.10.2.1 (b) channel integration method
RF Output Power Method	<input type="checkbox"/> ANSI C63.10 clause 6.10.3.1 Method 1 - spectral trace averaging
RF Output Power Method	<input type="checkbox"/> ANSI C63.10 clause 6.10.3.2 Method 2 - zero-span mode with trace averaging

### 4.2.4. Test Setup Layout

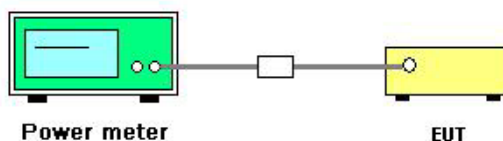

### 4.2.5. Test Deviation

There is no deviation with the original standard.

### 4.2.6. EUT Operation during Test

The EUT was programmed to be in continuously transmitting mode.

#### 4.2.7. Test Result of Peak Output Power

Temperature	25°C	Humidity	63%
Test Engineer	Robert Chang	Configurations	IEEE 802.11n
Test Date	Sep. 04, 2012		

##### Configuration IEEE 802.11n MCS0 20MHz

Channel	Frequency	Conducted Power (dBm)		Total Conducted Power (dBm)	Max. Limit (dBm)	Result
		Ant. 1	Ant. 2			
1	2412 MHz	24.70	24.58	27.65	30.00	Complies
6	2437 MHz	26.29	26.49	29.40	30.00	Complies
11	2462 MHz	23.52	24.73	27.18	30.00	Complies

##### Configuration IEEE 802.11n MCS0 40MHz

Channel	Frequency	Conducted Power (dBm)		Total Conducted Power (dBm)	Max. Limit (dBm)	Result
		Ant. 1	Ant. 2			
3	2422 MHz	24.72	24.88	27.81	30.00	Complies
6	2437 MHz	24.76	24.98	27.88	30.00	Complies
9	2452 MHz	22.72	23.96	26.39	30.00	Complies

Temperature	25°C	Humidity	63%
Test Engineer	Robert Chang	Configurations	IEEE 802.11b/g
Test Date	Sep. 04, 2012		

**Configuration IEEE 802.11b / Ant. 1**

Channel	Frequency	Conducted Power (dBm)	Max. Limit (dBm)	Result
1	2412 MHz	24.86	30.00	Complies
6	2437 MHz	26.19	30.00	Complies
11	2462 MHz	25.43	30.00	Complies

**Configuration IEEE 802.11g**

Channel	Frequency	Conducted Power (dBm)		Total Conducted Power (dBm)	Max. Limit (dBm)	Result
		Ant. 1	Ant. 2			
1	2412 MHz	25.32	25.28	28.31	30.00	Complies
6	2437 MHz	26.31	26.50	29.42	30.00	Complies
11	2462 MHz	24.42	25.12	27.79	30.00	Complies

### 4.3. Average Output Power Measurement

#### 4.3.1. Measuring Instruments and Setting

Please refer to section 5 of equipments list in this report. The following table is the setting of the power meter.

Power Meter Parameter	Setting
Bandwidth	50MHz bandwidth is greater than the EUT emission bandwidth
Detector	Average

#### 4.3.2. Test Procedures

Spectrum Parameter	Setting
RF Output Power Method	<input checked="" type="checkbox"/> ANSI C63.10 clause 6.10.2.1 (a) power meter method
RF Output Power Method	<input type="checkbox"/> ANSI C63.10 clause 6.10.2.1 (b) channel integration method
RF Output Power Method	<input type="checkbox"/> ANSI C63.10 clause 6.10.3.1 Method 1 - spectral trace averaging
RF Output Power Method	<input type="checkbox"/> ANSI C63.10 clause 6.10.3.2 Method 2 - zero-span mode with trace averaging

#### 4.3.3. Test Setup Layout

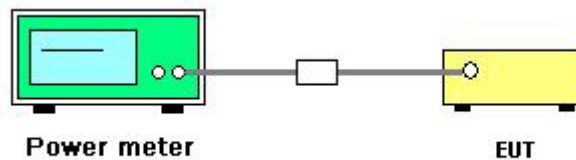

#### 4.3.4. Test Deviation

There is no deviation with the original standard.

#### 4.3.5. EUT Operation during Test

The EUT was programmed to be in continuously transmitting mode.

Note: Average output power is only for Maximum Permissible Exposure use.

#### 4.3.6. Test Result of Average Output Power

Temperature	25°C	Humidity	63%
Test Engineer	Robert Chang	Configurations	IEEE 802.11n
Test Date	Sep. 04, 2012		

##### Configuration IEEE 802.11n MCS0 20MHz

Channel	Frequency	Average Conducted Power (dBm)		
		Ant. 1	Ant. 2	Total
1	2412 MHz	16.61	16.03	19.34
6	2437 MHz	23.60	24.25	26.95
11	2462 MHz	14.51	16.01	18.33

##### Configuration IEEE 802.11n MCS0 40MHz

Channel	Frequency	Average Conducted Power (dBm)		
		Ant. 1	Ant. 2	Total
3	2422 MHz	16.72	16.97	19.86
6	2437 MHz	16.93	16.91	19.93
9	2452 MHz	13.45	14.69	17.12



Temperature	25°C	Humidity	63%
Test Engineer	Robert Chang	Configurations	IEEE 802.11b/g
Test Date	Sep. 04, 2012		

**Configuration IEEE 802.11b / Ant. 1**

Channel	Frequency	Average Conducted Power (dBm)
1	2412 MHz	21.67
6	2437 MHz	23.97
11	2462 MHz	22.38

**Configuration IEEE 802.11g**

Channel	Frequency	Average Conducted Power (dBm)		
		Ant. 1	Ant. 2	Total
1	2412 MHz	18.31	17.52	20.94
6	2437 MHz	23.07	23.70	26.41
11	2462 MHz	15.85	16.87	19.40

## 4.4. Power Spectral Density Measurement

### 4.4.1. Limit

For digitally modulated systems, the power spectral density conducted from the intentional radiator to the antenna shall not be greater than 8 dBm in any 3 kHz band during any time interval of continuous transmission.

### 4.4.2. Measuring Instruments and Setting

Please refer to section 5 of equipments list in this report. The following table is the setting of Spectrum Analyzer.

Spectrum Parameter	Setting
Attenuation	Auto
Span Frequency	Set the analyzer span to 5-30% greater than the EBW.
RB	100 kHz
VB	300 kHz
Detector	PEAK
Trace	MAX HOLD
Sweep Time	AUTO

### 4.4.3. Test Procedures

1. Use this procedure when the maximum conducted output power in the fundamental emission is used to demonstrate compliance. The EUT must be configured to transmit continuously at full power over the measurement duration.
2. Ensure that the number of measurement points in the sweep  $\geq 2 \times \text{span}/\text{RBW}$  (use of a greater number of measurement points than this minimum requirement is recommended).
3. Use the peak marker function to determine the maximum level in any 100 kHz band segment within the fundamental EBW.
4. Scale the observed power level to an equivalent level in 3 kHz by adjusting (reducing) the measured power by a bandwidth correction factor (BWCF) where:  $\text{BWCF} = 10\log(3 \text{ kHz}/100 \text{ kHz}) = -15.2 \text{ dB}$ .
5. The resulting PSD level must be  $\leq 8 \text{ dBm}$ .
6. When measuring power spectral density with multiple antenna systems, add every result of the values by mathematic formula.

#### 4.4.4. Test Setup Layout

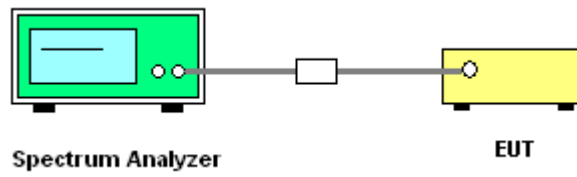

#### 4.4.5. Test Deviation

There is no deviation with the original standard.

#### 4.4.6. EUT Operation during Test

The EUT was programmed to be in continuously transmitting mode.

#### 4.4.7. Test Result of Power Spectral Density

Temperature	25°C	Humidity	63%
Test Engineer	Robert Chang	Configurations	IEEE 802.11n

##### Configuration IEEE 802.11n MCS0 20MHz / Ant.1 + Ant. 2

Frequency	Power Density (dBm/100kHz)		BWCF factor (100KHz to 3KHz)	Power Density (dBm/3kHz)		Single Port. Limit (dBm/3kHz)	Result
	ANT-1	ANT-2		ANT-1	ANT-2		
2412 MHz	4.26	4.86	-15.23	-10.97	-10.37	4.99	Complies
2437 MHz	13.12	14.26	-15.23	-2.11	-0.97	4.99	Complies
2462 MHz	2.51	4.37	-15.23	-12.72	-10.86	4.99	Complies

##### Configuration IEEE 802.11n MCS0 40MHz / Ant.1 + Ant. 2

Frequency	Power Density (dBm/100kHz)		BWCF factor (100KHz to 3KHz)	Power Density (dBm/3kHz)		Single Port. Limit (dBm/3kHz)	Result
	ANT-1	ANT-2		ANT-1	ANT-2		
2422 MHz	2.36	2.98	-15.23	-12.87	-12.25	4.99	Complies
2437 MHz	2.60	2.24	-15.23	-12.63	-12.99	4.99	Complies
2452 MHz	-0.95	0.43	-15.23	-16.18	-14.80	4.99	Complies

Temperature	25°C	Humidity	63%
Test Engineer	Robert Chang	Configurations	IEEE 802.11b/g

**Configuration IEEE 802.11b / Ant. 1**

Frequency	Power Density (dBm/100kHz)	BWCF factor (100KHz to 3KHz)	Total Power Density (dBm/3kHz)	Max. Limit (dBm/3kHz)	Result
2412 MHz	13.44	-15.23	-1.79	8.00	Complies
2437 MHz	14.94	-15.23	-0.29	8.00	Complies
2462 MHz	13.84	-15.23	-1.39	8.00	Complies

**Configuration IEEE 802.11g / Ant.1 + Ant. 2**

Frequency	Power Density (dBm/100kHz)		BWCF factor (100KHz to 3KHz)	Power Density (dBm/3kHz)		Single Port. Limit (dBm/3kHz)	Result
	ANT-1	ANT-2		ANT-1	ANT-2		
2412 MHz	6.40	5.81	-15.23	-8.83	-9.42	4.99	Complies
2437 MHz	12.01	13.10	-15.23	-3.22	-2.13	4.99	Complies
2462 MHz	3.57	5.81	-15.23	-11.66	-9.42	4.99	Complies

Note 1: All the test values were listed in the report.

For plots, only the channel with maximum results was shown.

### Power Density Plot on Configuration IEEE 802.11n MCS0 20MHz / Ant. 1 / 2437 MHz

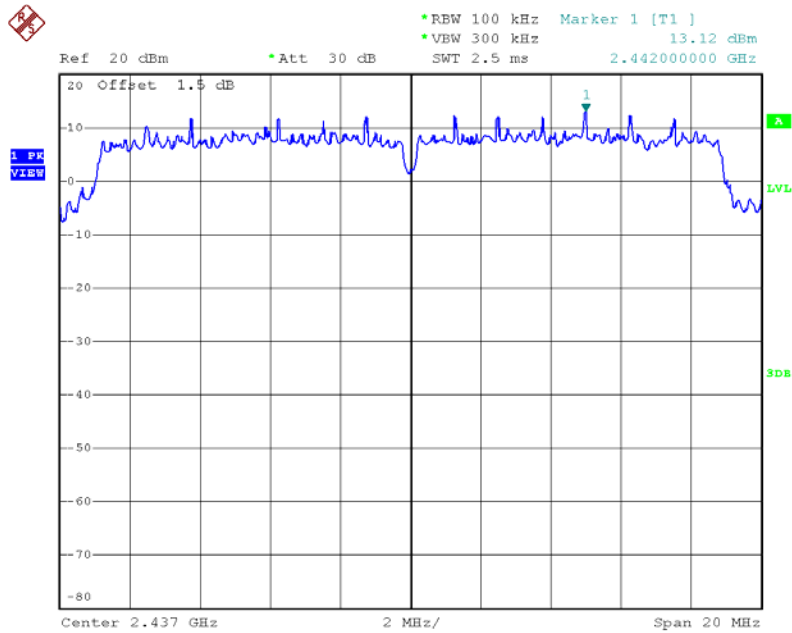

Date: 4.SEP.2012 14:32:16

### Power Density Plot on Configuration IEEE 802.11n MCS0 20MHz / Ant. 2 / 2437 MHz

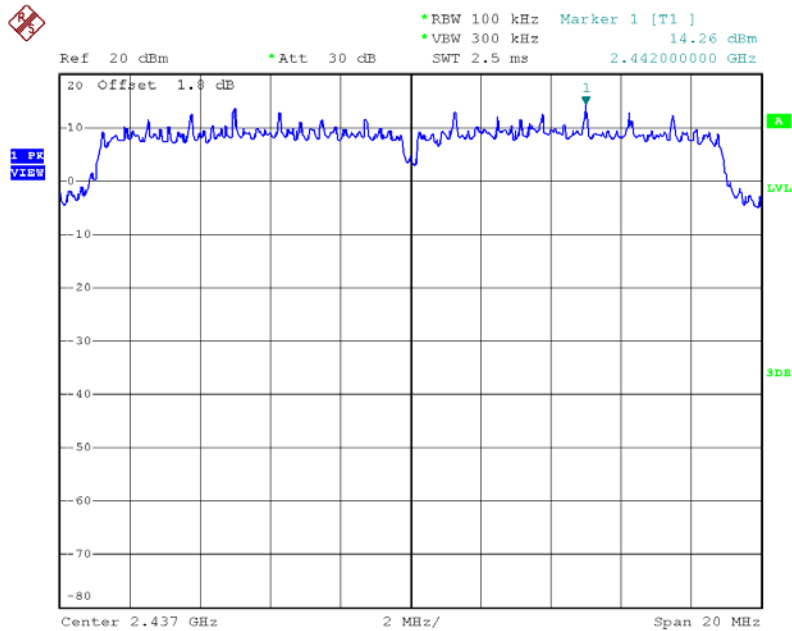

Date: 4.SEP.2012 14:31:49

### Power Density Plot on Configuration IEEE 802.11n MCS0 40MHz / Ant. 1 / 2437 MHz

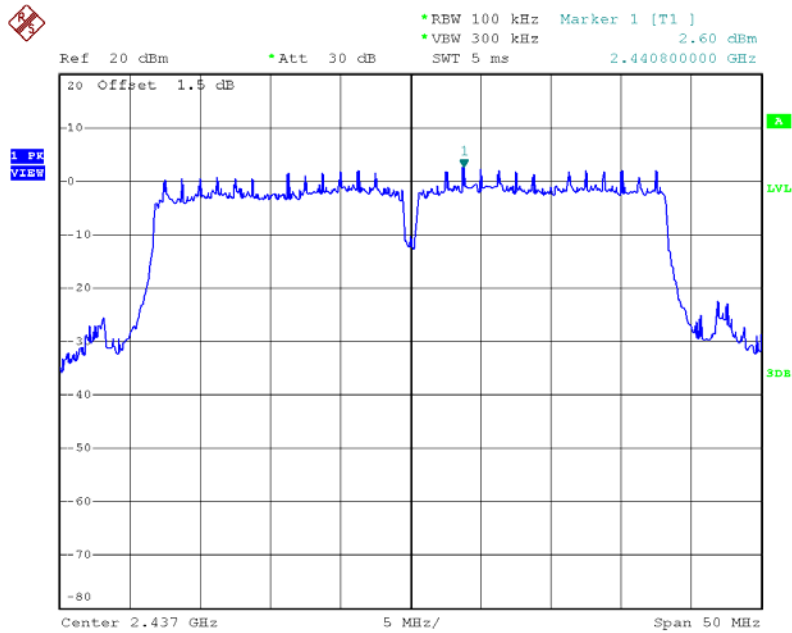

Date: 4.SEP.2012 14:45:37

### Power Density Plot on Configuration IEEE 802.11n MCS0 40MHz / Ant. 2 / 2437 MHz

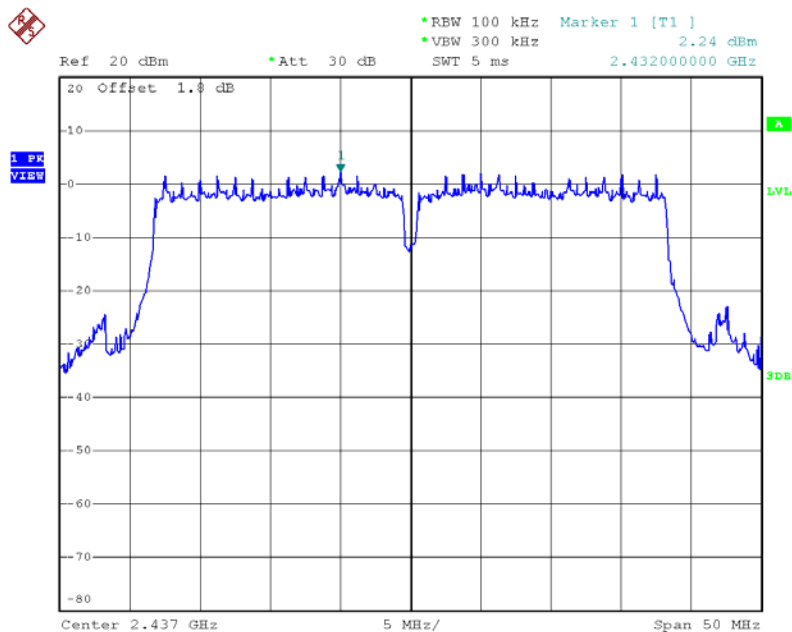

Date: 4.SEP.2012 14:44:40

### Power Density Plot on Configuration IEEE 802.11b / Ant. 1 / 2437 MHz

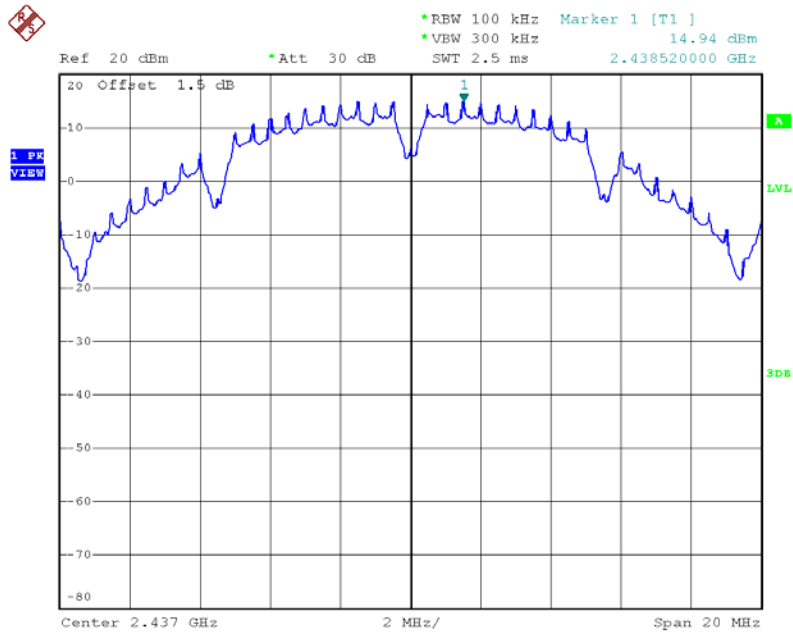

Date: 4.SEP.2012 13:20:44



Power Density Plot on Configuration IEEE 802.11g / Ant. 1 / 2437 MHz

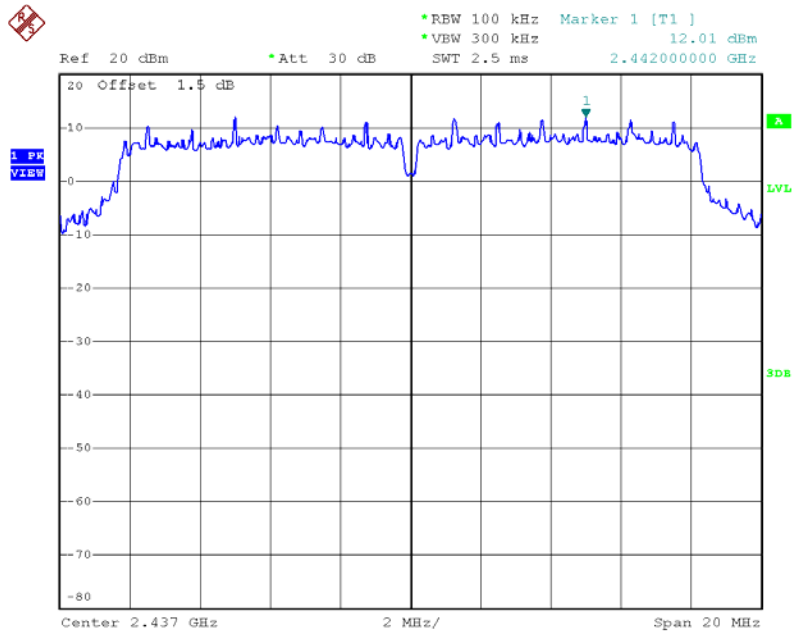

Date: 4.SEP.2012 13:59:23

Power Density Plot on Configuration IEEE 802.11g / Ant. 2 / 2437 MHz

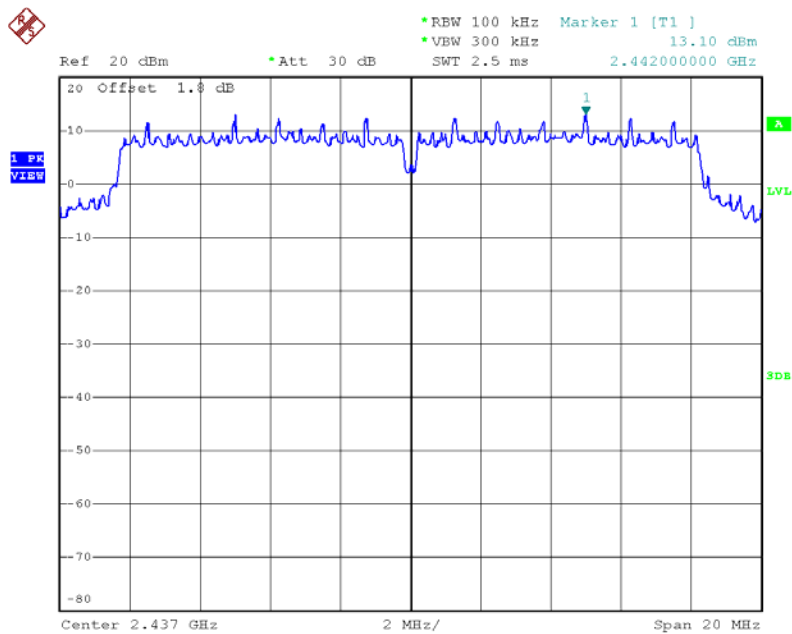

Date: 4.SEP.2012 13:58:22

## 4.5. 6dB Spectrum Bandwidth Measurement

### 4.5.1. Limit

For digital modulation systems, the minimum 6 dB bandwidth shall be at least 500 kHz.

### 4.5.2. Measuring Instruments and Setting

Please refer to section 5 of equipments list in this report. The following table is the setting of spectrum analyzer.

Spectrum Parameters	Setting
Attenuation	Auto
Span Frequency	> 6dB Bandwidth
RB	1-5 % of the emission bandwidth (EBW)
VB	$\geq 3 \times \text{RBW}$
Detector	Peak
Trace	Max Hold
Sweep Time	Auto

### 4.5.3. Test Procedures

1. The transmitter output (antenna port) was connected to the spectrum analyzer in peak hold mode.
2. The resolution bandwidth of 100 kHz and the video bandwidth of 100 kHz were used.
3. Measured the spectrum width with power higher than 6dB below carrier.

### 4.5.4. Test Setup Layout

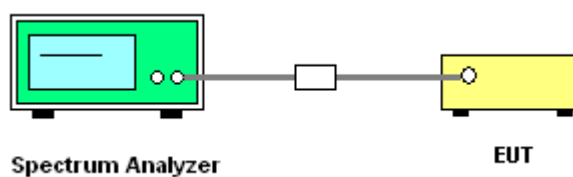

### 4.5.5. Test Deviation

There is no deviation with the original standard.

### 4.5.6. EUT Operation during Test

The EUT was programmed to be in continuously transmitting mode.

#### 4.5.7. Test Result of 6dB Spectrum Bandwidth

Temperature	25°C	Humidity	63%
Test Engineer	Robert Chang	Configurations	IEEE 802.11n

##### Configuration IEEE 802.11n MCS0 20MHz / Ant. 1 + Ant. 2

Channel	Frequency	6dB Bandwidth (MHz)	99% Occupied Bandwidth (MHz)	Min. Limit (kHz)	Test Result
1	2412 MHz	16.48	18.08	500	Complies
6	2437 MHz	16.48	28.48	500	Complies
11	2462 MHz	16.56	18.08	500	Complies

##### Configuration IEEE 802.11n MCS0 40MHz / Ant. 1 + Ant. 2

Channel	Frequency	6dB Bandwidth (MHz)	99% Occupied Bandwidth (MHz)	Min. Limit (kHz)	Test Result
3	2422 MHz	36.12	36.72	500	Complies
6	2437 MHz	35.88	36.72	500	Complies
9	2452 MHz	36.00	36.72	500	Complies

Temperature	25°C	Humidity	63%
Test Engineer	Robert Chang	Configurations	IEEE 802.11b/g

**Configuration IEEE 802.11b / Ant. 1**

Channel	Frequency	6dB Bandwidth (MHz)	99% Occupied Bandwidth (MHz)	Min. Limit (kHz)	Test Result
1	2412 MHz	9.04	12.00	500	Complies
6	2437 MHz	9.68	14.48	500	Complies
11	2462 MHz	9.12	12.00	500	Complies

**Configuration IEEE 802.11g / Ant. 1 + Ant. 2**

Channel	Frequency	6dB Bandwidth (MHz)	99% Occupied Bandwidth (MHz)	Min. Limit (kHz)	Test Result
1	2412 MHz	16.40	17.28	500	Complies
6	2437 MHz	16.24	26.08	500	Complies
11	2462 MHz	16.24	17.04	500	Complies

Note: All the test values were listed in the report.

For plots, only the channel with maximum results was shown.

6 dB Bandwidth Plot on Configuration IEEE 802.11n MCS0 20MHz / Ant. 1 + Ant. 2 / 2437 MHz

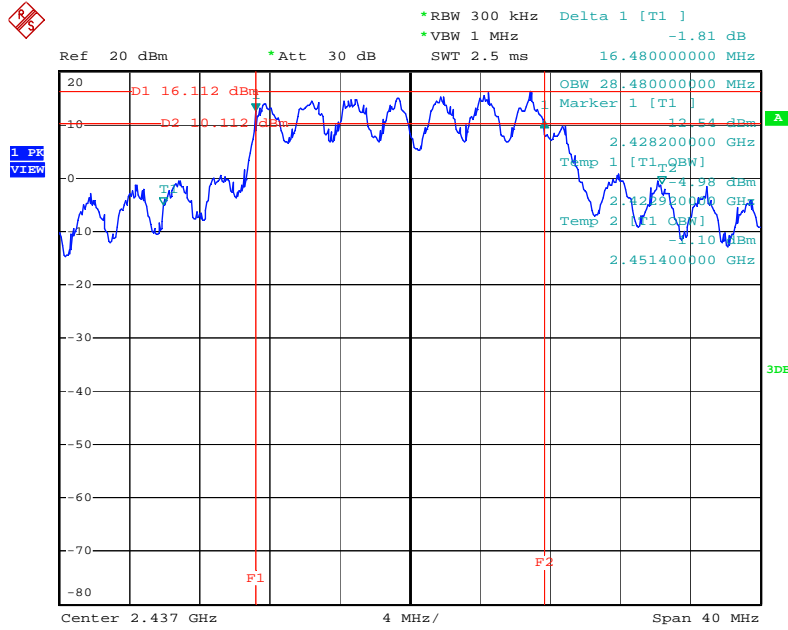

Date: 4.SEP.2012 15:35:26

6 dB Bandwidth Plot on Configuration IEEE 802.11n MCS0 40MHz / Ant. 1 + Ant. 2 / 2452 MHz

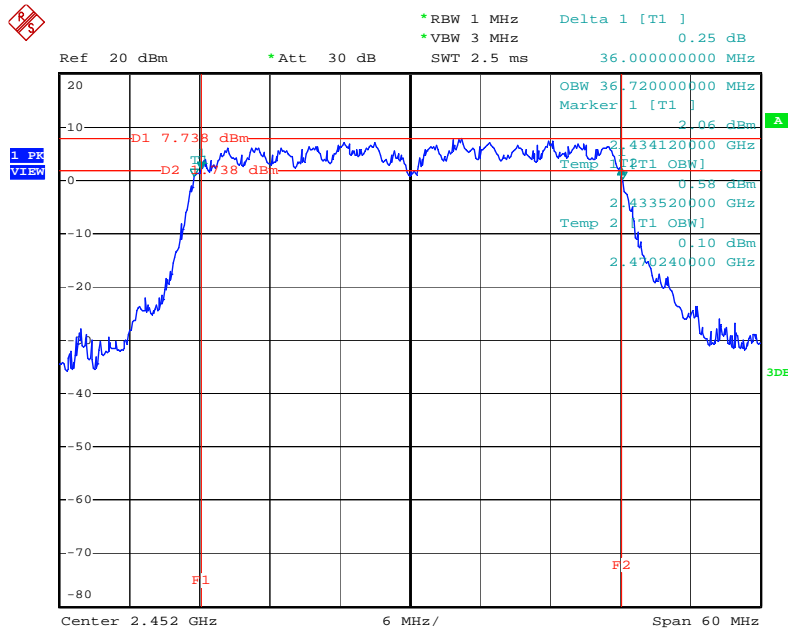

Date: 4.SEP.2012 15:40:19

### 6 dB Bandwidth Plot on Configuration IEEE 802.11b / Ant. 1 / 2437 MHz

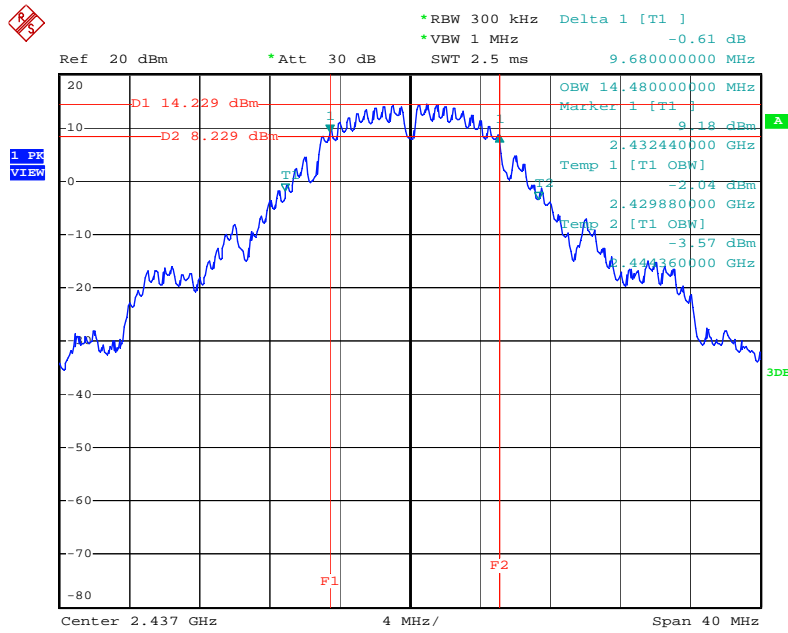

Date: 4.SEP.2012 15:25:13

### 6 dB Bandwidth Plot on Configuration IEEE 802.11g / Ant. 1 / 2437 MHz

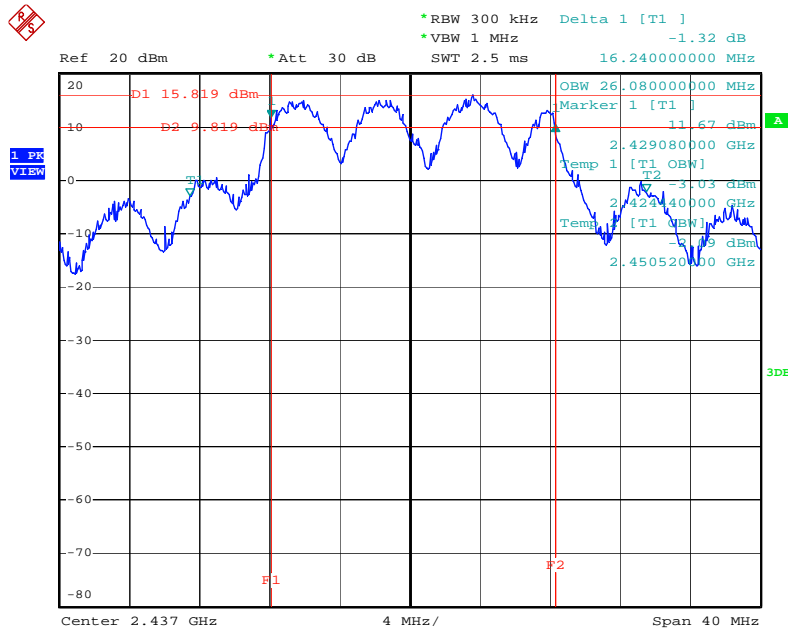

Date: 4.SEP.2012 15:30:21

## 4.6. Radiated Emissions Measurement

### 4.6.1. Limit

20dBc in any 100 kHz bandwidth outside the operating frequency band. In case the emission fall within the restricted band specified on 15.205(a), then the 15.209(a) limit in the table below has to be followed.

Frequencies (MHz)	Field Strength (micorvolts/meter)	Measurement Distance (meters)
0.009~0.490	2400/F(KHz)	300
0.490~1.705	24000/F(KHz)	30
1.705~30.0	30	30
30~88	100	3
88~216	150	3
216~960	200	3
Above 960	500	3

### 4.6.2. Measuring Instruments and Setting

Please refer to section 5 of equipments list in this report. The following table is the setting of spectrum analyzer and receiver.

Spectrum Parameter	Setting
Attenuation	Auto
Start Frequency	1GHz
Stop Frequency	10th carrier harmonic
RB / VB (Emission in restricted band)	1MHz / 3MHz for Peak, 1MHz / 10Hz for Average
RB / VB (Emission in non-restricted band)	1MHz / 3MHz for peak

Receiver Parameter	Setting
Attenuation	Auto
Start ~ Stop Frequency	9kHz~150kHz / RB 200Hz for QP
Start ~ Stop Frequency	150kHz~30MHz / RB 9kHz for QP
Start ~ Stop Frequency	30MHz~1GHz / RB 120kHz for QP

#### 4.6.3. Test Procedures

1. Configure the EUT according to ANSI C63.10. The EUT was placed on the top of the turntable 0.8 meter above ground. The phase center of the receiving antenna mounted on the top of a height-variable antenna tower was placed 3 meters far away from the turntable.
2. Power on the EUT and all the supporting units. The turntable was rotated by 360 degrees to determine the position of the highest radiation.
3. The height of the broadband receiving antenna was varied between one meter and four meters above ground to find the maximum emissions field strength of both horizontal and vertical polarization.
4. For each suspected emissions, the antenna tower was scan (from 1 m to 4 m) and then the turntable was rotated (from 0 degree to 360 degrees) to find the maximum reading.
5. Set the test-receiver system to Peak or CISPR quasi-peak Detect Function with specified bandwidth under Maximum Hold Mode.
6. For emissions above 1GHz, use 1MHz VBW and 3MHz RBW for peak reading. Then 1MHz RBW and 10Hz VBW for average reading in spectrum analyzer.
7. When the radiated emissions limits are expressed in terms of the average value of the emissions, and pulsed operation is employed, the measurement field strength shall be determined by averaging over one complete pulse train, including blanking intervals, as long as the pulse train does not exceed 0.1 seconds. As an alternative (provided the transmitter operates for longer than 0.1 seconds) or in cases where the pulse train exceeds 0.1 seconds, the measured field strength shall be determined from the average absolute voltage during a 0.1 second interval during which the field strength is at its maximum value.
8. If the emissions level of the EUT in peak mode was 3 dB lower than the average limit specified, then testing will be stopped and peak values of EUT will be reported, otherwise, the emissions which do not have 3 dB margin will be repeated one by one using the quasi-peak method for below 1GHz.
9. For testing above 1GHz, the emissions level of the EUT in peak mode was lower than average limit (that means the emissions level in peak mode also complies with the limit in average mode), then testing will be stopped and peak values of EUT will be reported, otherwise, the emissions will be measured in average mode again and reported.
10. In case the emission is lower than 30MHz, loop antenna has to be used for measurement and the recorded data should be QP measured by receiver. High – Low scan is not required in this case.



#### 4.6.4. Test Setup Layout

For Radiated Emissions below 1GHz

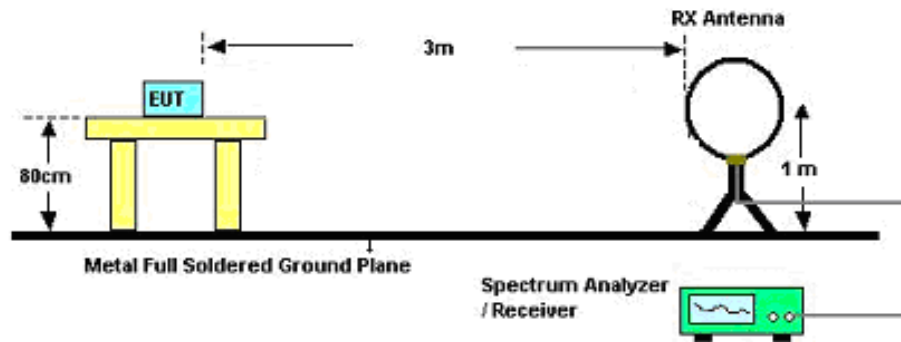

For Radiated Emissions above 1GHz

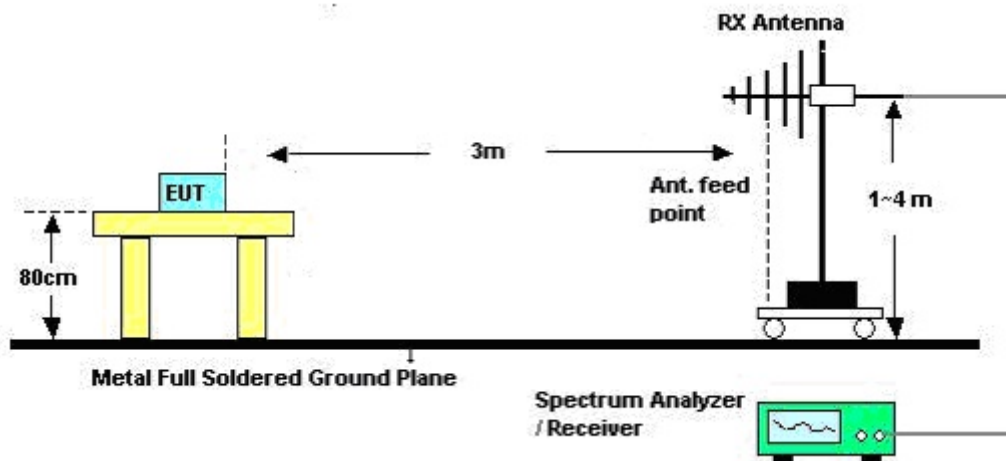

#### 4.6.5. Test Deviation

There is no deviation with the original standard.

#### 4.6.6. EUT Operation during Test

The EUT was programmed to be in continuously transmitting mode.

#### 4.6.7. Results of Radiated Emissions (9kHz~30MHz)

Temperature	26°C	Humidity	60%
Test Engineer	Magic Lai	Configurations	CTX
Test Date	Sep. 04, 2012		

Freq. (MHz)	Level (dBuV)	Over Limit (dB)	Limit Line (dBuV)	Remark
-	-	-	-	See Note

Note:

The amplitude of spurious emissions which are attenuated by more than 20 dB below the permissible value has no need to be reported.

Distance extrapolation factor =  $40 \log (\text{specific distance} / \text{test distance})$  (dB);

Limit line = specific limits (dBuV) + distance extrapolation factor.

4.6.8. Results of Radiated Emissions (30MHz~1GHz)

Temperature	26°C	Humidity	60%
Test Engineer	Magic Lai	Configurations	CTX
Test Mode	Mode 1		

Horizontal

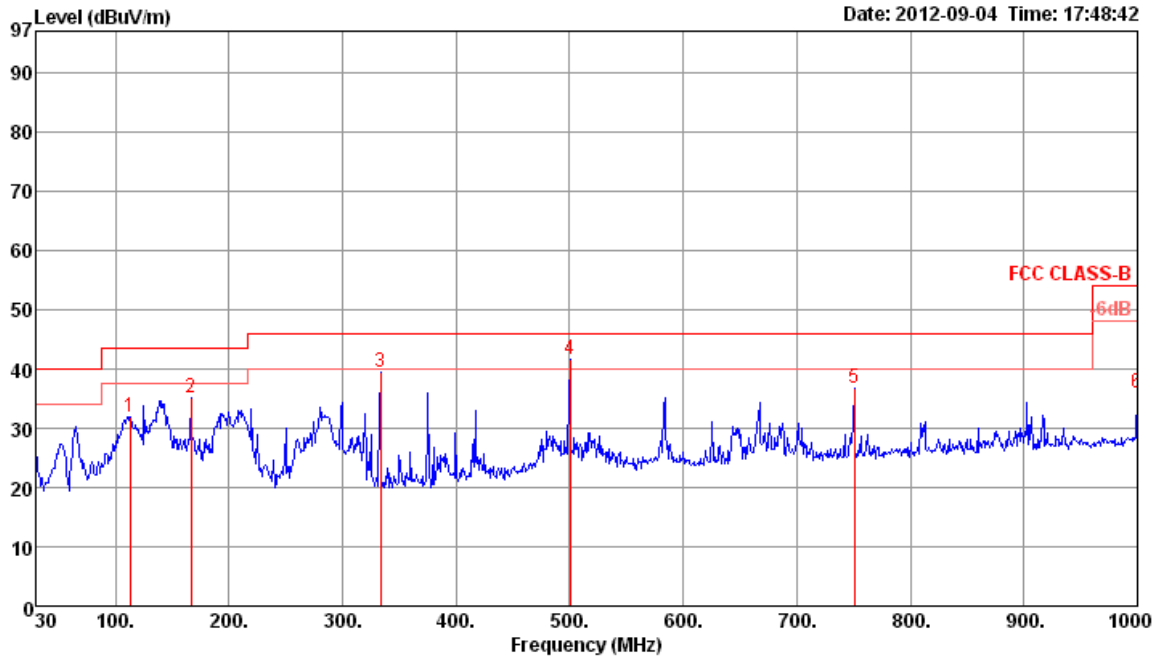

	Freq	Level	Limit	Over	Read	Cable	Preamp	Antenna	T/Pos	A/Pos	Remark	Pol/Phase
	MHz	dBuV/m	dBuV/m	dB	dBuV	dB	dB	dB/m	deg	cm		
1	113.42	31.90	43.50	-11.60	46.22	1.20	27.54	12.02	0	100	Peak	HORIZONTAL
2	166.77	35.25	43.50	-8.25	48.45	1.53	27.27	12.54	0	100	Peak	HORIZONTAL
3	333.61	39.57	46.00	-6.43	50.25	2.17	27.13	14.28	0	100	Peak	HORIZONTAL
4	500.45	41.58	46.00	-4.42	49.35	2.70	28.10	17.63	0	100	Peak	HORIZONTAL
5	750.71	36.62	46.00	-9.38	41.49	3.50	27.80	19.43	0	100	Peak	HORIZONTAL
6	1000.00	36.01	54.00	-17.99	38.02	3.70	27.00	21.29	0	100	Peak	HORIZONTAL

Vertical

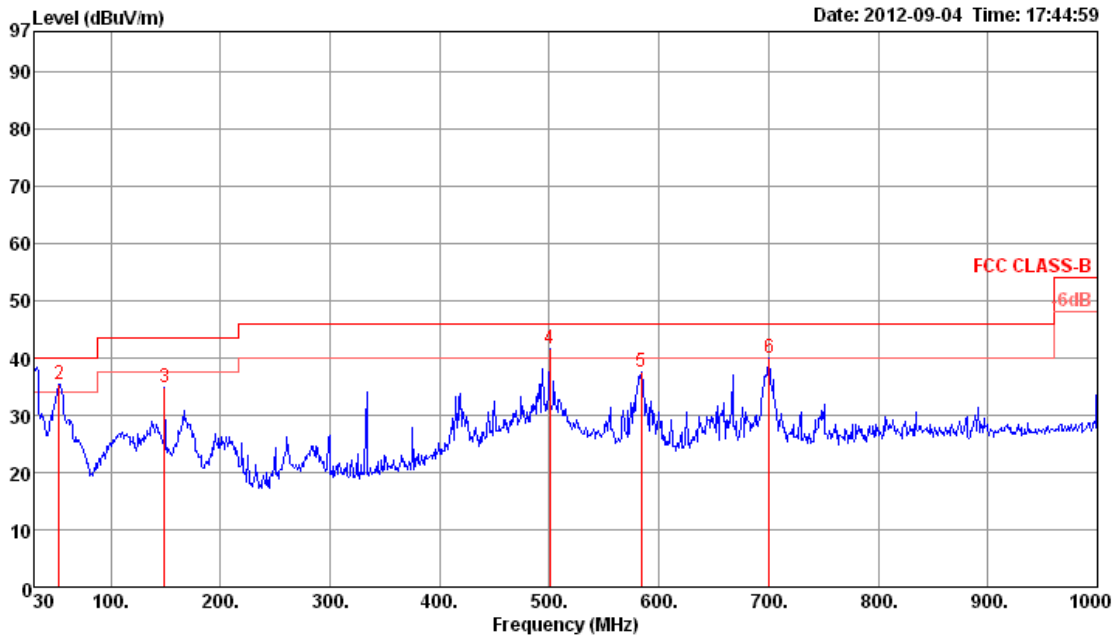

	Freq	Level	Limit Line	Over Limit	Read Level	Cable Loss	Preamp Factor	Antenna Factor	T/Pos	A/Pos	Remark	Pol/Phase
	MHz	dBuV/m	dBuV/m	dB	dBuV	dB	dB	dB/m	deg	cm		
1	30.65	36.92	40.00	-3.08	46.00	0.50	27.80	18.22	264	117	QP	VERTICAL
2	53.28	35.52	40.00	-4.48	54.55	0.76	27.79	8.00	0	400	Peak	VERTICAL
3	149.31	34.89	43.50	-8.61	48.90	1.45	27.36	11.90	0	400	Peak	VERTICAL
4	500.45	41.53	46.00	-4.47	49.30	2.70	28.10	17.63	0	400	Peak	VERTICAL
5	583.87	37.55	46.00	-8.45	44.20	2.87	28.10	18.58	0	400	Peak	VERTICAL
6	700.27	39.99	46.00	-6.01	45.59	3.30	27.99	19.09	0	400	Peak	VERTICAL

Note:

The amplitude of spurious emissions which are attenuated by more than 20 dB below the permissible value has no need to be reported.

Emission level (dBuV/m) = 20 log Emission level (uV/m).

Corrected Reading: Antenna Factor + Cable Loss + Read Level - Preamp Factor = Level.

Temperature	26°C	Humidity	60%
Test Engineer	Magic Lai	Configurations	CTX
Test Mode	Mode 2		

Horizontal

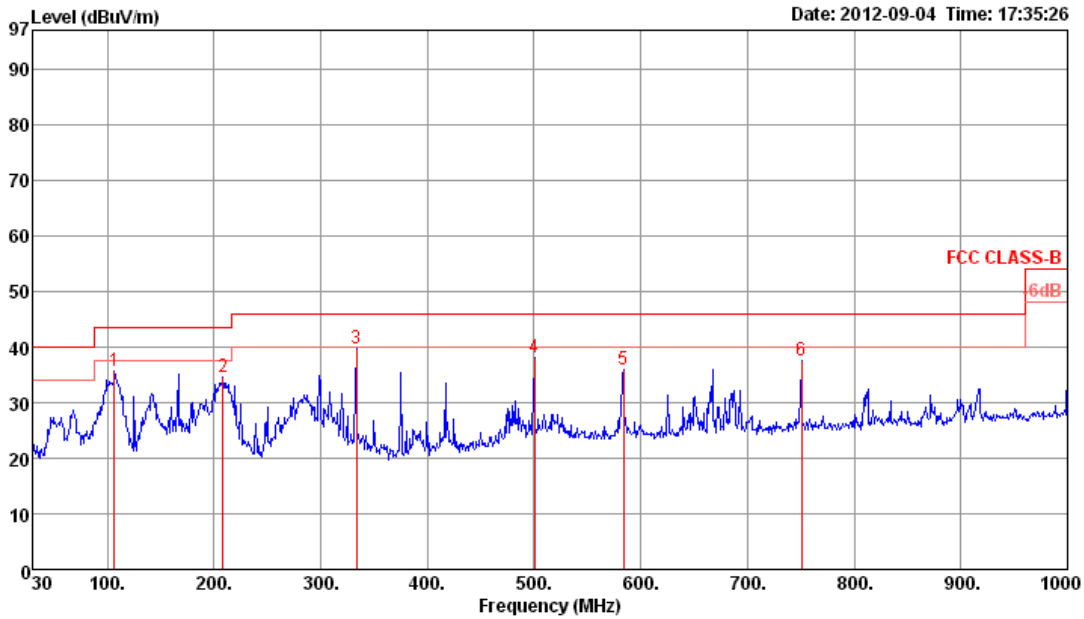

	Freq	Level	Limit Line	Over Limit	Read Level	Cable Loss	Preamp Factor	Antenna Factor	T/Pos	A/Pos	Remark	Pol/Phase
	MHz	dBuV/m	dBuV/m	dB	dBuV	dB	dB	dB/m	deg	cm		
1	106.63	35.79	43.50	-7.71	50.66	1.20	27.57	11.50	0	100	Peak	HORIZONTAL
2	208.48	34.61	43.50	-8.89	50.27	1.73	27.08	9.69	0	100	Peak	HORIZONTAL
3	333.61	39.76	46.00	-6.24	50.44	2.17	27.13	14.28	0	100	Peak	HORIZONTAL
4	500.45	38.19	46.00	-7.81	45.96	2.70	28.10	17.63	0	100	Peak	HORIZONTAL
5	583.87	36.01	46.00	-9.99	42.66	2.87	28.10	18.58	0	100	Peak	HORIZONTAL
6	750.71	37.47	46.00	-8.53	42.34	3.50	27.80	19.43	0	100	Peak	HORIZONTAL

*Vertical*

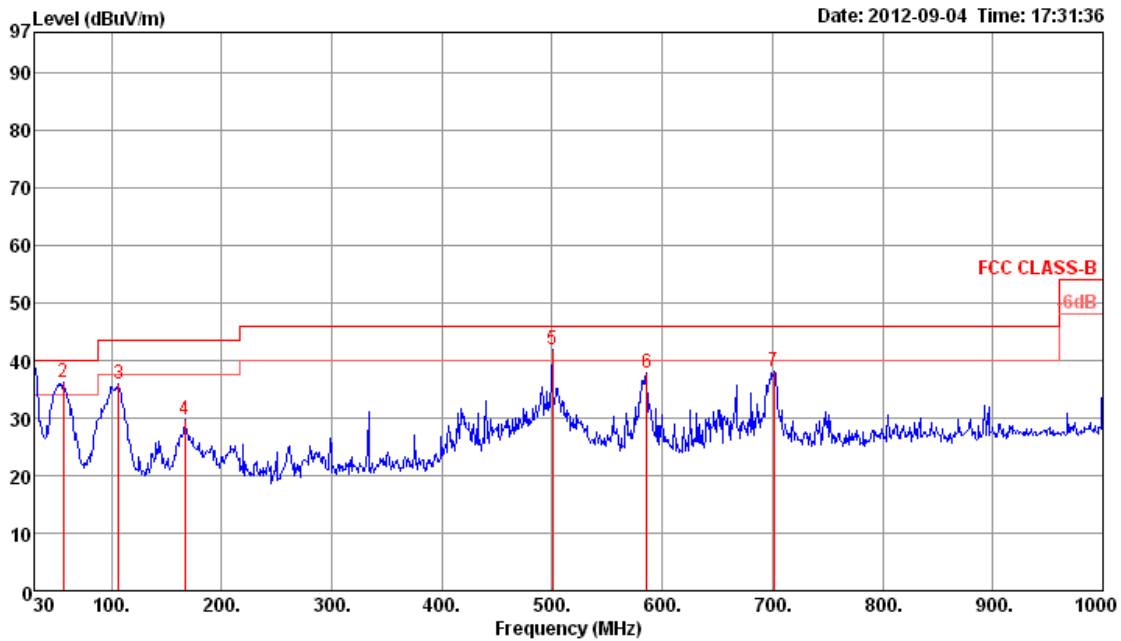

	Freq	Level	Limit Line	Over Limit	Read Level	Cable Loss	Preamp Factor	Antenna Factor	T/Pos	A/Pos	Remark	Pol/Phase
	MHz	dBuV/m	dBuV/m	dB	dBuV	dB	dB	dB/m	deg	cm		
1	q	30.10	36.46	40.00	-3.54	45.00	0.50	27.80	18.76	265	119 QP	VERTICAL
2	p	56.19	36.16	40.00	-3.84	55.67	0.80	27.78	7.47	0	400 Peak	VERTICAL
3		106.63	35.81	43.50	-7.69	50.68	1.20	27.57	11.50	0	400 Peak	VERTICAL
4		166.77	29.72	43.50	-13.78	42.92	1.53	27.27	12.54	0	400 Peak	VERTICAL
5	!	500.45	41.75	46.00	-4.25	49.52	2.70	28.10	17.63	0	400 Peak	VERTICAL
6		585.81	37.92	46.00	-8.08	44.55	2.87	28.10	18.60	0	400 Peak	VERTICAL
7		701.24	38.06	46.00	-7.94	43.65	3.30	27.99	19.10	0	400 Peak	VERTICAL

Note:

The amplitude of spurious emissions which are attenuated by more than 20 dB below the permissible value has no need to be reported.

Emission level (dBuV/m) = 20 log Emission level (uV/m).

Corrected Reading: Antenna Factor + Cable Loss + Read Level - Preamp Factor = Level.

4.6.9. Results for Radiated Emissions (1GHz~10<sup>th</sup> Harmonic)

Temperature	26°C	Humidity	60%
Test Engineer	Magic Lai	Configurations	IEEE 802.11n MCS0 20MHz Ch 1 / Ant. 1 + Ant. 2
Test Date	Aug. 30, 2012		

*Horizontal*

	Freq	Level	Limit Line	Over Limit	Read Level	Cable Loss	Antenna Factor	Preamp Factor	Remark	A/Pos	T/Pos	Pol/Phase
	MHz	dBuV/m	dBuV/m	dB	dBuV	dB	dB/m	dB		cm	deg	
1	4823.09	42.49	74.00	-31.51	41.15	3.31	33.06	35.03	Peak	100	135	HORIZONTAL
2	4825.73	29.92	54.00	-24.08	28.58	3.31	33.06	35.03	Average	100	135	HORIZONTAL

*Vertical*

	Freq	Level	Limit Line	Over Limit	Read Level	Cable Loss	Antenna Factor	Preamp Factor	Remark	A/Pos	T/Pos	Pol/Phase
	MHz	dBuV/m	dBuV/m	dB	dBuV	dB	dB/m	dB		cm	deg	
1	4824.72	29.56	54.00	-24.44	28.22	3.31	33.06	35.03	Average	119	312	VERTICAL
2	4825.39	43.01	74.00	-30.99	41.67	3.31	33.06	35.03	Peak	119	312	VERTICAL

Temperature	26°C	Humidity	60%
Test Engineer	Magic Lai	Configurations	IEEE 802.11n MCS0 20MHz Ch 6 / Ant. 1 + Ant. 2
Test Date	Aug. 30, 2012		

### Horizontal

	Freq	Level	Limit Line	Over Limit	Read Level	Cable Loss	Antenna Factor	Preamp Factor	Remark	A/Pos	T/Pos	Pol/Phase
	MHz	dBuV/m	dBuV/m	dB	dBuV	dB	dB/m	dB		cm	deg	
1	4873.14	50.87	74.00	-23.13	49.41	3.33	33.16	35.03	Peak	117	131	HORIZONTAL
2	4873.52	38.29	54.00	-15.71	36.83	3.33	33.16	35.03	Average	117	131	HORIZONTAL
3	7316.67	54.29	74.00	-19.71	49.67	4.06	35.96	35.40	Peak	151	101	HORIZONTAL
4	7316.72	40.87	54.00	-13.13	36.25	4.06	35.96	35.40	Average	151	101	HORIZONTAL

### Vertical

	Freq	Level	Limit Line	Over Limit	Read Level	Cable Loss	Antenna Factor	Preamp Factor	Remark	A/Pos	T/Pos	Pol/Phase
	MHz	dBuV/m	dBuV/m	dB	dBuV	dB	dB/m	dB		cm	deg	
1	4875.11	38.98	54.00	-15.02	37.52	3.33	33.16	35.03	Average	116	95	VERTICAL
2	4877.51	51.66	74.00	-22.34	50.20	3.33	33.16	35.03	Peak	116	95	VERTICAL
3	7309.85	53.93	74.00	-20.07	49.31	4.06	35.96	35.40	Peak	100	48	VERTICAL
4	7309.99	41.28	54.00	-12.72	36.66	4.06	35.96	35.40	Average	100	48	VERTICAL



Temperature	26°C	Humidity	60%
Test Engineer	Magic Lai	Configurations	IEEE 802.11n MCS0 20MHz Ch 11 / Ant. 1 + Ant. 2
Test Date	Aug. 30, 2012		

#### Horizontal

	Freq	Level	Limit Line	Over Limit	Read Level	Cable Loss	Antenna Factor	Preamp Factor	Remark	A/Pos	T/Pos	Pol/Phase
	MHz	dBuV/m	dBuV/m	dB	dBuV	dB	dB/m	dB		cm	deg	
1	4923.42	30.73	54.00	-23.27	29.13	3.35	33.26	35.01	Average	100	136	HORIZONTAL
2	4925.35	43.46	74.00	-30.54	41.86	3.35	33.26	35.01	Peak	100	136	HORIZONTAL
3	7380.47	44.43	74.00	-29.57	39.68	4.06	36.09	35.40	Peak	100	335	HORIZONTAL
4	7393.36	32.02	54.00	-21.98	27.23	4.06	36.13	35.40	Average	100	335	HORIZONTAL

#### Vertical

	Freq	Level	Limit Line	Over Limit	Read Level	Cable Loss	Antenna Factor	Preamp Factor	Remark	A/Pos	T/Pos	Pol/Phase
	MHz	dBuV/m	dBuV/m	dB	dBuV	dB	dB/m	dB		cm	deg	
1	4922.61	31.88	54.00	-22.12	30.28	3.35	33.26	35.01	Average	127	95	VERTICAL
2	4930.01	44.01	74.00	-29.99	42.41	3.35	33.26	35.01	Peak	127	95	VERTICAL
3	7386.19	45.26	74.00	-28.74	40.51	4.06	36.09	35.40	Peak	100	245	VERTICAL
4	7388.50	32.02	54.00	-21.98	27.27	4.06	36.09	35.40	Average	100	245	VERTICAL

Temperature	26°C	Humidity	60%
Test Engineer	Magic Lai	Configurations	IEEE 802.11n MCS0 40MHz Ch 3 / Ant. 1 + Ant. 2
Test Date	Aug. 30, 2012		

### Horizontal

	Freq	Level	Limit Line	Over Limit	Read Level	CableAntenna Loss Factor	Preamp Factor	Remark	A/Pos	T/Pos	Pol/Phase	
	MHz	dBuV/m	dBuV/m	dB	dBuV	dB	dB/m	dB	cm	deg		
1	4844.05	29.46	54.00	-24.54	28.08	3.32	33.09	35.03	Average	100	356	HORIZONTAL
2	4849.43	41.75	74.00	-32.25	40.37	3.32	33.09	35.03	Peak	100	356	HORIZONTAL

### Vertical

	Freq	Level	Limit Line	Over Limit	Read Level	CableAntenna Loss Factor	Preamp Factor	Remark	A/Pos	T/Pos	Pol/Phase	
	MHz	dBuV/m	dBuV/m	dB	dBuV	dB	dB/m	dB	cm	deg		
1	4839.82	40.81	74.00	-33.19	39.43	3.32	33.09	35.03	Peak	100	167	VERTICAL
2	4852.65	29.46	54.00	-24.54	28.08	3.32	33.09	35.03	Average	100	167	VERTICAL

Temperature	26°C	Humidity	60%
Test Engineer	Magic Lai	Configurations	IEEE 802.11n MCS0 40MHz Ch 6 / Ant. 1 + Ant. 2
Test Date	Aug. 30, 2012		

### Horizontal

	Freq	Level	Limit Line	Over Limit	Read Level	Cable Loss	Antenna Factor	Preamp Factor	Remark	A/Pos	T/Pos	Pol/Phase
	MHz	dBuV/m	dBuV/m	dB	dBuV	dB	dB/m	dB		cm	deg	
1	4878.95	43.51	74.00	-30.49	42.05	3.33	33.16	35.03	Peak	100	170	HORIZONTAL
2	4883.33	30.41	54.00	-23.59	28.95	3.33	33.16	35.03	Average	100	170	HORIZONTAL
3	7320.86	44.45	74.00	-29.55	39.83	4.06	35.96	35.40	Peak	100	132	HORIZONTAL
4	7325.86	31.96	54.00	-22.04	27.31	4.06	35.99	35.40	Average	100	132	HORIZONTAL

### Vertical

	Freq	Level	Limit Line	Over Limit	Read Level	Cable Loss	Antenna Factor	Preamp Factor	Remark	A/Pos	T/Pos	Pol/Phase
	MHz	dBuV/m	dBuV/m	dB	dBuV	dB	dB/m	dB		cm	deg	
1	4875.88	29.07	54.00	-24.93	27.61	3.33	33.16	35.03	Average	100	51	VERTICAL
2	4878.28	41.02	74.00	-32.98	39.56	3.33	33.16	35.03	Peak	100	50	VERTICAL
3	7322.15	44.42	74.00	-29.58	39.80	4.06	35.96	35.40	Peak	100	285	VERTICAL
4	7324.03	31.83	54.00	-22.17	27.21	4.06	35.96	35.40	Average	100	285	VERTICAL

Temperature	26°C	Humidity	60%
Test Engineer	Magic Lai	Configurations	IEEE 802.11n MCS0 40MHz Ch 9 / Ant. 1 + Ant. 2
Test Date	Aug. 30, 2012		

#### Horizontal

	Freq	Level	Limit Line	Over Limit	Read Level	CableAntenna Loss	Antenna Factor	Preamp Factor	Remark	A/Pos	T/Pos	Pol/Phase
	MHz	dBuV/m	dBuV/m	dB	dBuV	dB	dB/m	dB		cm	deg	
1	4903.95	30.04	54.00	-23.96	28.53	3.34	33.19	35.02	Average	100	183	HORIZONTAL
2	4907.46	42.11	74.00	-31.89	40.56	3.34	33.23	35.02	Peak	100	183	HORIZONTAL
3	7347.15	44.84	74.00	-29.16	40.16	4.06	36.02	35.40	Peak	100	316	HORIZONTAL
4	7354.37	32.01	54.00	-21.99	27.33	4.06	36.02	35.40	Average	100	316	HORIZONTAL

#### Vertical

	Freq	Level	Limit Line	Over Limit	Read Level	CableAntenna Loss	Antenna Factor	Preamp Factor	Remark	A/Pos	T/Pos	Pol/Phase
	MHz	dBuV/m	dBuV/m	dB	dBuV	dB	dB/m	dB		cm	deg	
1	4905.78	42.47	74.00	-31.53	40.92	3.34	33.23	35.02	Peak	100	116	VERTICAL
2	4910.06	30.08	54.00	-23.92	28.53	3.34	33.23	35.02	Average	100	116	VERTICAL
3	7344.27	32.04	54.00	-21.96	27.36	4.06	36.02	35.40	Average	100	144	VERTICAL
4	7359.70	45.22	74.00	-28.78	40.50	4.06	36.06	35.40	Peak	100	144	VERTICAL

#### Note:

The amplitude of spurious emissions which are attenuated by more than 20 dB below the permissible value has no need to be reported.

Emission level (dBuV/m) = 20 log Emission level (uV/m).

Corrected Reading: Antenna Factor + Cable Loss + Read Level - Preamp Factor = Level.

Temperature	26°C	Humidity	60%
Test Engineer	Magic Lai	Configurations	IEEE 802.11b CH 1 / Ant. 1
Test Date	Aug. 30, 2012		

### Horizontal

	Freq	Level	Limit Line	Over Limit	Read Level	Cable Loss	Antenna Factor	Preamp Factor	Remark	A/Pos	T/Pos	Pol/Phase
	MHz	dBuV/m	dBuV/m	dB	dBuV	dB	dB/m	dB		cm	deg	
1	4823.94	43.94	54.00	-10.06	42.60	3.31	33.06	35.03	Average	112	69	HORIZONTAL
2	4824.00	48.03	74.00	-25.97	46.69	3.31	33.06	35.03	Peak	112	69	HORIZONTAL

### Vertical

	Freq	Level	Limit Line	Over Limit	Read Level	Cable Loss	Antenna Factor	Preamp Factor	Remark	A/Pos	T/Pos	Pol/Phase
	MHz	dBuV/m	dBuV/m	dB	dBuV	dB	dB/m	dB		cm	deg	
1	4823.95	45.95	74.00	-28.05	44.61	3.31	33.06	35.03	Peak	110	79	VERTICAL
2	4823.98	39.06	54.00	-14.94	37.72	3.31	33.06	35.03	Average	110	79	VERTICAL

Temperature	26°C	Humidity	60%
Test Engineer	Magic Lai	Configurations	IEEE 802.11b CH 6 / Ant. 1
Test Date	Aug. 30, 2012		

### Horizontal

	Freq	Level	Limit	Over	Read	Cable	Antenna	Preamp	Remark	A/Pos	T/Pos	PoI/Phase
	MHz	dBuV/m	dBuV/m	dB	dBuV	dB	dB/m	dB		cm	deg	
1	4873.98	46.07	54.00	-7.93	44.61	3.33	33.16	35.03	Average	100	326	HORIZONTAL
2	4874.03	50.10	74.00	-23.90	48.64	3.33	33.16	35.03	Peak	100	326	HORIZONTAL
3	7311.71	51.50	54.00	-2.50	46.88	4.06	35.96	35.40	Average	142	50	HORIZONTAL
4	7311.93	56.52	74.00	-17.48	51.90	4.06	35.96	35.40	Peak	142	50	HORIZONTAL

### Vertical

	Freq	Level	Limit	Over	Read	Cable	Antenna	Preamp	Remark	A/Pos	T/Pos	PoI/Phase
	MHz	dBuV/m	dBuV/m	dB	dBuV	dB	dB/m	dB		cm	deg	
1	4873.99	49.62	54.00	-4.38	48.16	3.33	33.16	35.03	Average	110	304	VERTICAL
2	4873.99	52.48	74.00	-21.52	51.02	3.33	33.16	35.03	Peak	110	304	VERTICAL
3	7311.67	46.12	54.00	-7.88	41.50	4.06	35.96	35.40	Average	99	27	VERTICAL
4	7311.90	52.46	74.00	-21.54	47.84	4.06	35.96	35.40	Peak	99	27	VERTICAL

Temperature	26°C	Humidity	60%
Test Engineer	Magic Lai	Configurations	IEEE 802.11b CH 11 / Ant. 1
Test Date	Aug. 30, 2012		

### Horizontal

	Freq	Level	Limit	Over	Read	Cable	Antenna	Preamp	Remark	A/Pos	T/Pos	Pol/Phase
	MHz	dBuV/m	dBuV/m	dB	dBuV	dB	dB/m	dB		cm	deg	
1	4923.99	45.16	54.00	-8.84	43.56	3.35	33.26	35.01	Average	100	83	HORIZONTAL
2	4924.06	49.58	74.00	-24.42	47.98	3.35	33.26	35.01	Peak	100	83	HORIZONTAL
3	7386.80	43.78	54.00	-10.22	39.03	4.06	36.09	35.40	Average	143	100	HORIZONTAL
4	7388.16	51.04	74.00	-22.96	46.29	4.06	36.09	35.40	Peak	143	100	HORIZONTAL

### Vertical

	Freq	Level	Limit	Over	Read	Cable	Antenna	Preamp	Remark	A/Pos	T/Pos	Pol/Phase
	MHz	dBuV/m	dBuV/m	dB	dBuV	dB	dB/m	dB		cm	deg	
1	4923.99	48.68	74.00	-25.32	47.08	3.35	33.26	35.01	Peak	101	58	VERTICAL
2	4924.02	44.57	54.00	-9.43	42.97	3.35	33.26	35.01	Average	101	58	VERTICAL
3	7386.56	46.29	74.00	-27.71	41.54	4.06	36.09	35.40	Peak	100	289	VERTICAL
4	7386.72	35.16	54.00	-18.84	30.41	4.06	36.09	35.40	Average	100	289	VERTICAL

Temperature	26°C	Humidity	60%
Test Engineer	Magic Lai	Configurations	IEEE 802.11g CH 1 / Ant. 1 + Ant. 2
Test Date	Aug. 30, 2012		

### Horizontal

	Freq	Level	Limit Line	Over Limit	Read Level	Cable Loss	Antenna Factor	Preamp Factor	Remark	A/Pos	T/Pos	Pol/Phase
	MHz	dBuV/m	dBuV/m	dB	dBuV	dB	dB/m	dB		cm	deg	
1	4823.18	42.94	74.00	-31.06	41.60	3.31	33.06	35.03	Peak	100	130	HORIZONTAL
2	4823.48	30.23	54.00	-23.77	28.89	3.31	33.06	35.03	Average	100	130	HORIZONTAL

### Vertical

	Freq	Level	Limit Line	Over Limit	Read Level	Cable Loss	Antenna Factor	Preamp Factor	Remark	A/Pos	T/Pos	Pol/Phase
	MHz	dBuV/m	dBuV/m	dB	dBuV	dB	dB/m	dB		cm	deg	
1	4823.72	42.25	74.00	-31.75	40.91	3.31	33.06	35.03	Peak	100	306	VERTICAL
2	4824.94	30.21	54.00	-23.79	28.87	3.31	33.06	35.03	Average	100	306	VERTICAL



Temperature	26°C	Humidity	60%
Test Engineer	Magic Lai	Configurations	IEEE 802.11g CH 6 / Ant. 1 + Ant. 2
Test Date	Aug. 30, 2012		

### Horizontal

	Freq	Level	Limit	Over	Read	Cable	Antenna	Preamp	Remark	A/Pos	T/Pos	Pol/Phase
	MHz	dBuV/m	dBuV/m	dB	dBuV	Loss	Factor	Factor		cm	deg	
1	4872.37	38.41	54.00	-15.59	36.95	3.33	33.16	35.03	Average	112	133	HORIZONTAL
2	4876.92	51.88	74.00	-22.12	50.42	3.33	33.16	35.03	Peak	112	133	HORIZONTAL
3	7310.90	52.79	74.00	-21.21	48.17	4.06	35.96	35.40	Peak	100	99	HORIZONTAL
4	7311.10	40.49	54.00	-13.51	35.87	4.06	35.96	35.40	Average	100	99	HORIZONTAL

### Vertical

	Freq	Level	Limit	Over	Read	Cable	Antenna	Preamp	Remark	A/Pos	T/Pos	Pol/Phase
	MHz	dBuV/m	dBuV/m	dB	dBuV	Loss	Factor	Factor		cm	deg	
1	4875.15	50.82	74.00	-23.18	49.36	3.33	33.16	35.03	Peak	124	70	VERTICAL
2	4875.86	38.68	54.00	-15.32	37.22	3.33	33.16	35.03	Average	124	70	VERTICAL
3	7309.75	53.49	74.00	-20.51	48.87	4.06	35.96	35.40	Peak	100	48	VERTICAL
4	7313.79	40.63	54.00	-13.37	36.01	4.06	35.96	35.40	Average	100	48	VERTICAL

Temperature	26°C	Humidity	60%
Test Engineer	Magic Lai	Configurations	IEEE 802.11g CH 11 / Ant. 1 + Ant. 2
Test Date	Aug. 30, 2012		

### Horizontal

	Freq	Level	Limit Line	Over Limit	Read Level	Cable Loss	Antenna Factor	Preamp Factor	Remark	A/Pos	T/Pos	Pol/Phase
	MHz	dBuV/m	dBuV/m	dB	dBuV	dB	dB/m	dB		cm	deg	
1	4927.89	31.96	54.00	-22.04	30.36	3.35	33.26	35.01	Average	100	138	HORIZONTAL
2	4932.89	44.05	74.00	-29.95	42.45	3.35	33.26	35.01	Peak	100	138	HORIZONTAL
3	7392.92	44.74	74.00	-29.26	39.95	4.06	36.13	35.40	Peak	100	124	HORIZONTAL
4	7394.27	32.18	54.00	-21.82	27.39	4.06	36.13	35.40	Average	100	124	HORIZONTAL

### Vertical

	Freq	Level	Limit Line	Over Limit	Read Level	Cable Loss	Antenna Factor	Preamp Factor	Remark	A/Pos	T/Pos	Pol/Phase
	MHz	dBuV/m	dBuV/m	dB	dBuV	dB	dB/m	dB		cm	deg	
1	4922.17	44.43	74.00	-29.57	42.83	3.35	33.26	35.01	Peak	127	97	VERTICAL
2	4926.28	33.09	54.00	-20.91	31.49	3.35	33.26	35.01	Average	127	97	VERTICAL
3	7384.75	45.12	74.00	-28.88	40.37	4.06	36.09	35.40	Peak	100	356	VERTICAL
4	7385.66	32.36	54.00	-21.64	27.61	4.06	36.09	35.40	Average	100	356	VERTICAL

### Note:

The amplitude of spurious emissions that are attenuated by more than 20dB below the permissible value has no need to be reported.

Emission level (dBuV/m) = 20 log Emission level (uV/m).

Corrected Reading: Antenna Factor + Cable Loss + Read Level - Preamp Factor = Level.

## 4.7. Band Edge Emissions Measurement

### 4.7.1. Limit

20dBc in any 100 kHz bandwidth outside the operating frequency band. In case the emission fall within the restricted band specified on 15.205(a), then the 15.209(a) limit in the table below has to be followed.

Frequencies (MHz)	Field Strength (micorvolts/meter)	Measurement Distance (meters)
0.009~0.490	2400/F(KHz)	300
0.490~1.705	24000/F(KHz)	30
1.705~30.0	30	30
30~88	100	3
88~216	150	3
216~960	200	3
Above 960	500	3

### 4.7.2. Measuring Instruments and Setting

Please refer to section 5 of equipments list in this report. The following table is the setting of the spectrum analyzer.

Spectrum Parameter	Setting
Attenuation	Auto
Span Frequency	100 MHz
RB / VB (Emission in restricted band)	1 MHz / 3MHz for Peak, 1 MHz / 10Hz for Average
RB / VB (Emission in non-restricted band)	100 KHz /300 KHz for Peak

### 4.7.3. Test Procedures

1. The test procedure is the same as section 4.5.3, only the frequency range investigated is limited to 100MHz around bandedges.
2. In case the emission is fail due to the used RB/VB is too wide, marker-delta method of FCC Public Notice DA00-705 will be followed.

### 4.7.4. Test Setup Layout

This test setup layout is the same as that shown in section 4.5.4.

### 4.7.5. Test Deviation

There is no deviation with the original standard.

### 4.7.6. EUT Operation during Test

The EUT was programmed to be in continuously transmitting mode.

#### 4.7.7. Test Result of Band Edge and Fundamental Emissions

Temperature	26°C	Humidity	60%
Test Engineer	Will Tung	Configurations	IEEE 802.11n MCS0 20MHz Ch 1, 6, 11 / Ant. 1 + Ant. 2
Test Date	Aug. 31, 2012		

##### Channel 1

	Freq	Level	Limit Line	Over Limit	Read Level	CableAntenna Loss	Antenna Factor	Preamp Factor	Remark	A/Pos	T/Pos	Pol/Phase
	MHz	dBuV/m	dBuV/m	dB	dBuV	dB	dB/m	dB		cm	deg	
1	2389.36	72.91	74.00	-1.09	42.53	2.21	28.17	0.00	Peak	126	114	VERTICAL
2	2389.52	53.51	54.00	-0.49	23.13	2.21	28.17	0.00	Average	126	114	VERTICAL
3	2409.76	111.09				2.22	28.21	0.00	Peak	126	114	VERTICAL
4	2414.72	100.73				2.22	28.21	0.00	Average	126	114	VERTICAL

Item 3, 4 are the fundamental frequency at 2412 MHz.

##### Channel 6

	Freq	Level	Limit Line	Over Limit	Read Level	CableAntenna Loss	Antenna Factor	Preamp Factor	Remark	A/Pos	T/Pos	Pol/Phase
	MHz	dBuV/m	dBuV/m	dB	dBuV	dB	dB/m	dB		cm	deg	
1	2389.68	52.36	54.00	-1.64	21.98	2.21	28.17	0.00	Average	106	307	VERTICAL
2	2389.68	65.23	74.00	-8.77	34.85	2.21	28.17	0.00	Peak	106	307	VERTICAL
3	2434.12	118.44				2.23	28.29	0.00	Peak	106	307	VERTICAL
4	2434.44	106.52				2.23	28.29	0.00	Average	106	307	VERTICAL
5	2483.82	69.28	74.00	-4.72	38.65	2.26	28.37	0.00	Peak	106	307	VERTICAL
6	2484.14	53.23	54.00	-0.77	22.60	2.26	28.37	0.00	Average	106	307	VERTICAL

Item 3, 4 are the fundamental frequency at 2437MHz.

##### Channel 11

	Freq	Level	Limit Line	Over Limit	Read Level	CableAntenna Loss	Antenna Factor	Preamp Factor	Remark	A/Pos	T/Pos	Pol/Phase
	MHz	dBuV/m	dBuV/m	dB	dBuV	dB	dB/m	dB		cm	deg	
1	2465.37	99.93				2.24	28.33	0.00	Average	119	242	VERTICAL
2	2465.69	110.97				2.24	28.33	0.00	Peak	119	242	VERTICAL
3	2483.50	53.21	54.00	-0.79	22.58	2.26	28.37	0.00	Average	119	242	VERTICAL
4	2483.50	71.75	74.00	-2.25	41.12	2.26	28.37	0.00	Peak	119	242	VERTICAL

Item 1, 2 are the fundamental frequency at 2462 MHz.

Temperature	26°C	Humidity	60%
Test Engineer	Will Tung	Configurations	IEEE 802.11n MCS0 40MHz Ch 3, 6, 9 / Ant. 1 + Ant. 2
Test Date	Aug. 31, 2012		

**Channel 3**

	Freq	Level	Limit Line	Over Limit	Read Level	Cable Loss	Antenna Factor	Preamp Factor	Remark	A/Pos	T/Pos	Pol/Phase
	MHz	dBuV/m	dBuV/m	dB	dBuV	dB	dB/m	dB		cm	deg	
1	2387.44	61.13	74.00	-12.87	30.75	2.21	28.17	0.00	Peak	155	217	VERTICAL
2	2390.00	53.38	54.00	-0.62	22.99	2.22	28.17	0.00	Average	155	217	VERTICAL
3	2424.56	103.60				2.23	28.25	0.00	Peak	155	217	VERTICAL
4	2427.45	97.51				2.23	28.25	0.00	Average	155	217	VERTICAL

Item 3, 4 are the fundamental frequency at 2422 MHz.

**Channel 6**

	Freq	Level	Limit Line	Over Limit	Read Level	Cable Loss	Antenna Factor	Preamp Factor	Remark	A/Pos	T/Pos	Pol/Phase
	MHz	dBuV/m	dBuV/m	dB	dBuV	dB	dB/m	dB		cm	deg	
1	2389.36	62.33	74.00	-11.67	31.95	2.21	28.17	0.00	Peak	130	230	VERTICAL
2	2389.68	47.16	54.00	-6.84	16.78	2.21	28.17	0.00	Average	130	230	VERTICAL
3	2447.26	109.03				2.24	28.29	0.00	Peak	130	230	VERTICAL
4	2449.18	97.60				2.24	28.29	0.00	Average	130	230	VERTICAL
5	2484.46	53.07	54.00	-0.93	22.44	2.26	28.37	0.00	Average	130	230	VERTICAL
6	2484.78	70.06	74.00	-3.94	39.43	2.26	28.37	0.00	Peak	130	230	VERTICAL

Item 3, 4 are the fundamental frequency at 2437MHz.

**Channel 9**

	Freq	Level	Limit Line	Over Limit	Read Level	Cable Loss	Antenna Factor	Preamp Factor	Remark	A/Pos	T/Pos	Pol/Phase
	MHz	dBuV/m	dBuV/m	dB	dBuV	dB	dB/m	dB		cm	deg	
1	2459.05	94.79				2.24	28.33	0.00	Average	102	40	VERTICAL
2	2463.86	106.85				2.24	28.33	0.00	Peak	102	40	VERTICAL
3	2484.46	53.60	54.00	-0.40	22.97	2.26	28.37	0.00	Average	102	40	VERTICAL
4	2489.27	67.72	74.00	-6.28	37.05	2.26	28.41	0.00	Peak	102	40	VERTICAL

Item 1, 2 are the fundamental frequency at 2452 MHz.

Note:

Emission level (dBuV/m) = 20 log Emission level (uV/m).

Corrected Reading: Antenna Factor + Cable Loss + Read Level - Preamp Factor = Level.

Temperature	26°C	Humidity	60%
Test Engineer	Will Tung	Configurations	IEEE 802.11b CH 1, 6, 11 / Ant. 1
Test Date	Aug. 31, 2012		

**Channel 1**

	Freq	Level	Limit Line	Over Limit	Read Level	Cable Loss	Antenna Factor	Preamp Factor	Remark	A/Pos	T/Pos	Pol/Phase
	MHz	dBuV/m	dBuV/m	dB	dBuV	dB	dB/m	dB		cm	deg	
1	2390.00	52.53	54.00	-1.47	22.14	2.22	28.17	0.00	Average	120	121	VERTICAL
2	2390.00	62.41	74.00	-11.59	32.02	2.22	28.17	0.00	Peak	120	121	VERTICAL
3	2412.96	115.06				2.22	28.21	0.00	Peak	120	121	VERTICAL
4	2413.76	110.95				2.22	28.21	0.00	Average	120	121	VERTICAL

Item 3, 4 are the fundamental frequency at 2412 MHz.

**Channel 6**

	Freq	Level	Limit Line	Over Limit	Read Level	Cable Loss	Antenna Factor	Preamp Factor	Remark	A/Pos	T/Pos	Pol/Phase
	MHz	dBuV/m	dBuV/m	dB	dBuV	dB	dB/m	dB		cm	deg	
1	2377.82	46.31	54.00	-7.69	15.97	2.21	28.13	0.00	Average	100	141	VERTICAL
2	2389.36	56.25	74.00	-17.75	25.87	2.21	28.17	0.00	Peak	100	141	VERTICAL
3	2435.40	112.51				2.23	28.29	0.00	Average	100	141	VERTICAL
4	2436.04	116.33				2.23	28.29	0.00	Peak	100	141	VERTICAL
5	2483.82	49.88	54.00	-4.12	19.25	2.26	28.37	0.00	Average	100	141	VERTICAL
6	2484.46	61.67	74.00	-12.33	31.04	2.26	28.37	0.00	Peak	100	141	VERTICAL

Item 3, 4 are the fundamental frequency at 2437MHz.

**Channel 11**

	Freq	Level	Limit Line	Over Limit	Read Level	Cable Loss	Antenna Factor	Preamp Factor	Remark	A/Pos	T/Pos	Pol/Phase
	MHz	dBuV/m	dBuV/m	dB	dBuV	dB	dB/m	dB		cm	deg	
1	2461.04	114.16				2.24	28.33	0.00	Peak	100	227	VERTICAL
2	2461.20	110.38				2.24	28.33	0.00	Average	100	227	VERTICAL
3	2483.50	53.71	54.00	-0.29	23.08	2.26	28.37	0.00	Average	100	227	VERTICAL
4	2483.66	61.98	74.00	-12.02	31.35	2.26	28.37	0.00	Peak	100	227	VERTICAL

Item 1, 2 are the fundamental frequency at 2462 MHz.

Temperature	26°C	Humidity	60%
Test Engineer	Will Tung	Configurations	IEEE 802.11g CH 1, 6, 11 / Ant. 1 + Ant. 2
Test Date	Aug. 31, 2012		

**Channel 1**

	Freq	Level	Limit Line	Over Limit	Read Level	Cable Loss	Antenna Factor	Preamp Factor	Remark	A/Pos	T/Pos	Pol/Phase
	MHz	dBuV/m	dBuV/m	dB	dBuV	dB	dB/m	dB		cm	deg	
1	2388.72	72.43	74.00	-1.57	42.05	2.21	28.17	0.00	Peak	103	247	VERTICAL
2	2389.84	53.20	54.00	-0.80	22.81	2.22	28.17	0.00	Average	103	247	VERTICAL
3	2408.80	113.61				2.22	28.21	0.00	Peak	103	247	VERTICAL
4	2409.28	103.43				2.22	28.21	0.00	Average	103	247	VERTICAL

Item 3, 4 are the fundamental frequency at 2412 MHz.

**Channel 6**

	Freq	Level	Limit Line	Over Limit	Read Level	Cable Loss	Antenna Factor	Preamp Factor	Remark	A/Pos	T/Pos	Pol/Phase
	MHz	dBuV/m	dBuV/m	dB	dBuV	dB	dB/m	dB		cm	deg	
1	2389.68	67.28	74.00	-6.72	36.90	2.21	28.17	0.00	Peak	125	243	VERTICAL
2	2390.00	51.75	54.00	-2.25	21.36	2.22	28.17	0.00	Average	125	243	VERTICAL
3	2439.89	109.55				2.23	28.29	0.00	Average	125	243	VERTICAL
4	2444.69	120.78				2.24	28.29	0.00	Peak	125	243	VERTICAL
5	2484.46	67.63	74.00	-6.37	37.00	2.26	28.37	0.00	Peak	125	243	VERTICAL
6	2484.78	53.43	54.00	-0.57	22.80	2.26	28.37	0.00	Average	125	243	VERTICAL

Item 3, 4 are the fundamental frequency at 2437 MHz.

**Channel 11**

	Freq	Level	Limit Line	Over Limit	Read Level	Cable Loss	Antenna Factor	Preamp Factor	Remark	A/Pos	T/Pos	Pol/Phase
	MHz	dBuV/m	dBuV/m	dB	dBuV	dB	dB/m	dB		cm	deg	
1	2458.31	112.90				2.24	28.33	0.00	Peak	124	248	VERTICAL
2	2458.64	102.42				2.24	28.33	0.00	Average	124	248	VERTICAL
3	2483.50	53.82	54.00	-0.18	23.19	2.26	28.37	0.00	Average	124	248	VERTICAL
4	2483.50	70.93	74.00	-3.07	40.30	2.26	28.37	0.00	Peak	124	248	VERTICAL

Item 1, 2 are the fundamental frequency at 2462 MHz.

Note:

Emission level (dBuV/m) = 20 log Emission level (uV/m).

Corrected Reading: Antenna Factor + Cable Loss + Read Level - Preamp Factor = Level.

For Emission not in Restricted Band

Plot on Configuration IEEE 802.11n MCS0 20MHz (Reference Level)

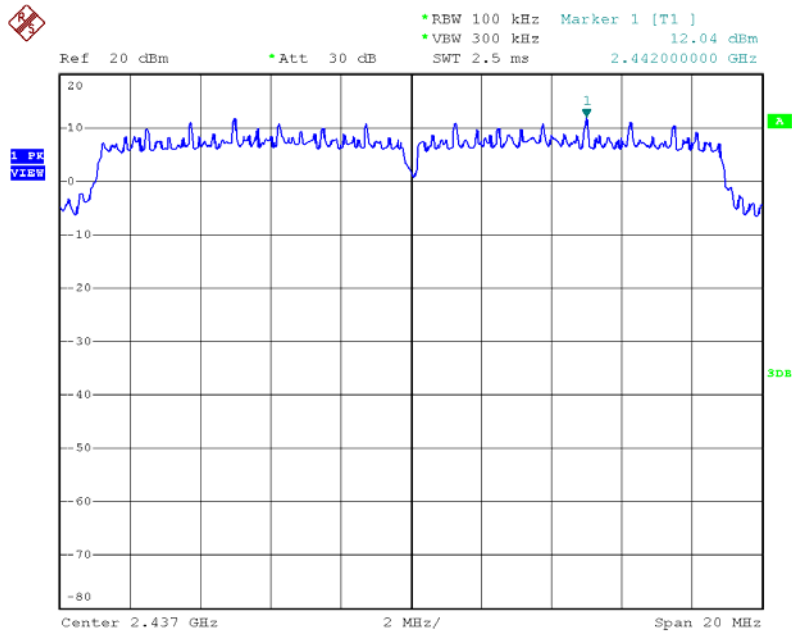

Date: 4.SEP.2012 14:34:05

Plot on Configuration IEEE 802.11n MCS0 20MHz / Ant. 1 + Ant. 2 / 2412 MHz (down 20dBc)

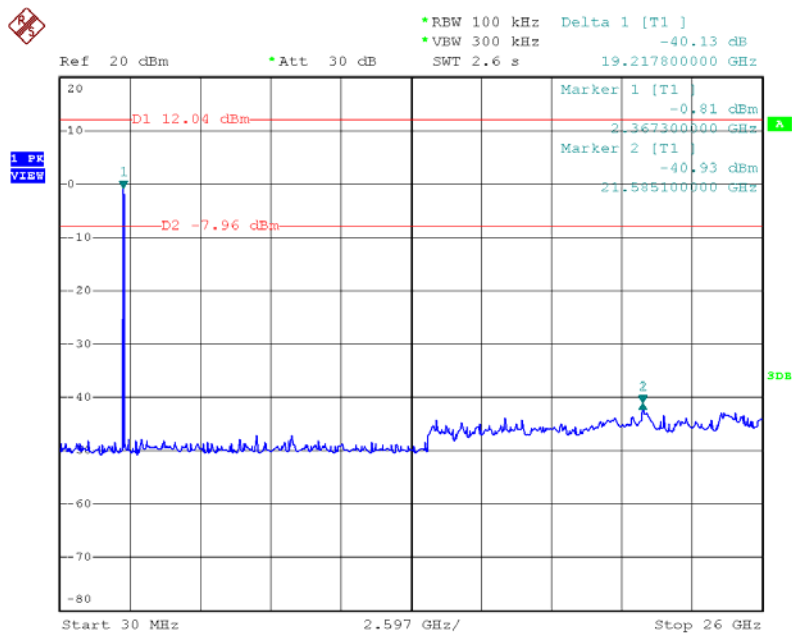

Date: 4.SEP.2012 14:36:07



Plot on Configuration IEEE 802.11n MCS0 20MHz / Ant. 1 + Ant. 2 / 2437 MHz (down 20dBc)

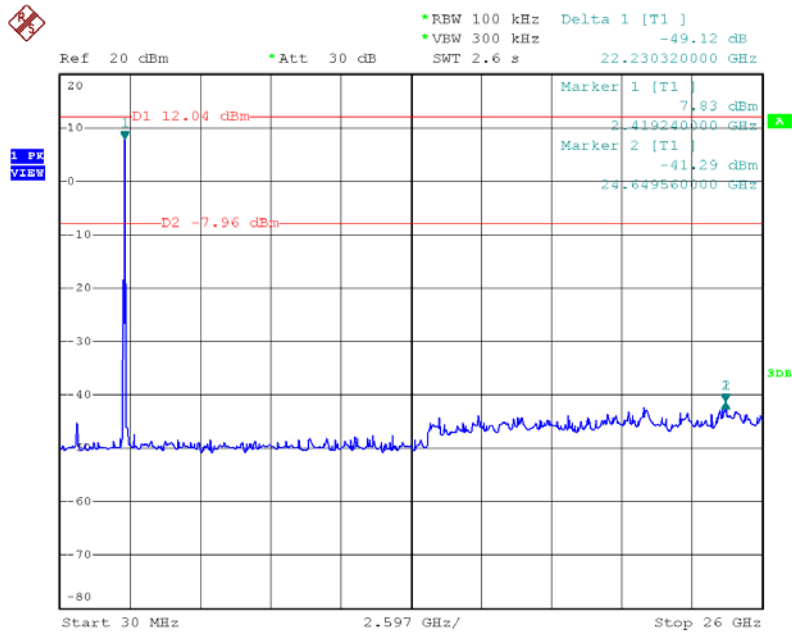

Date: 4.SEP.2012 14:35:08

Plot on Configuration IEEE 802.11n MCS0 20MHz / Ant. 1 + Ant. 2 / 2462 MHz (down 20dBc)

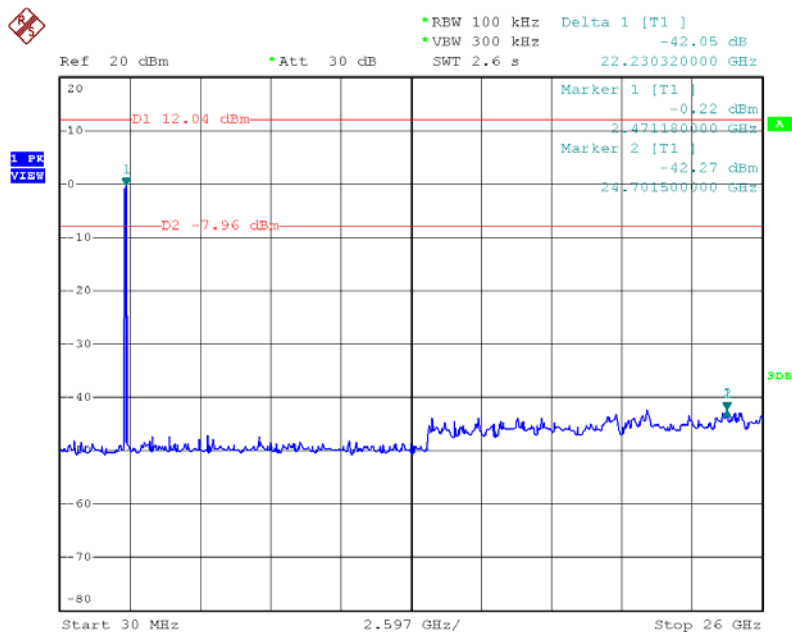

Date: 4.SEP.2012 14:37:52

Plot on Configuration IEEE 802.11n MCS0 40MHz (Reference Level)

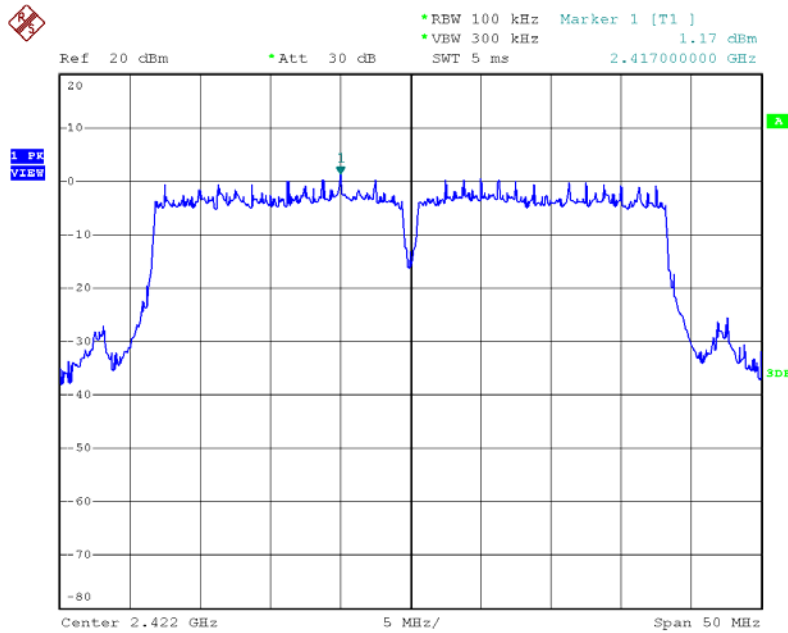

Date: 4.SEP.2012 14:47:48

Plot on Configuration IEEE 802.11n MCS0 40MHz / Ant. 1 + Ant. 2 / 2422 MHz (down 20dBc)

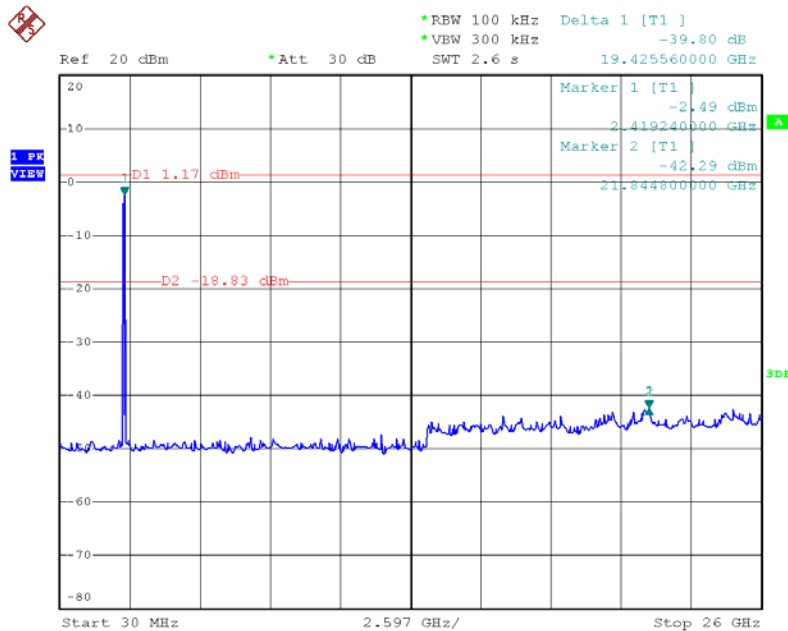

Date: 4.SEP.2012 14:48:50

Plot on Configuration IEEE 802.11n MCS0 40MHz / Ant. 1 + Ant. 2 / 2437 MHz (down 20dBc)

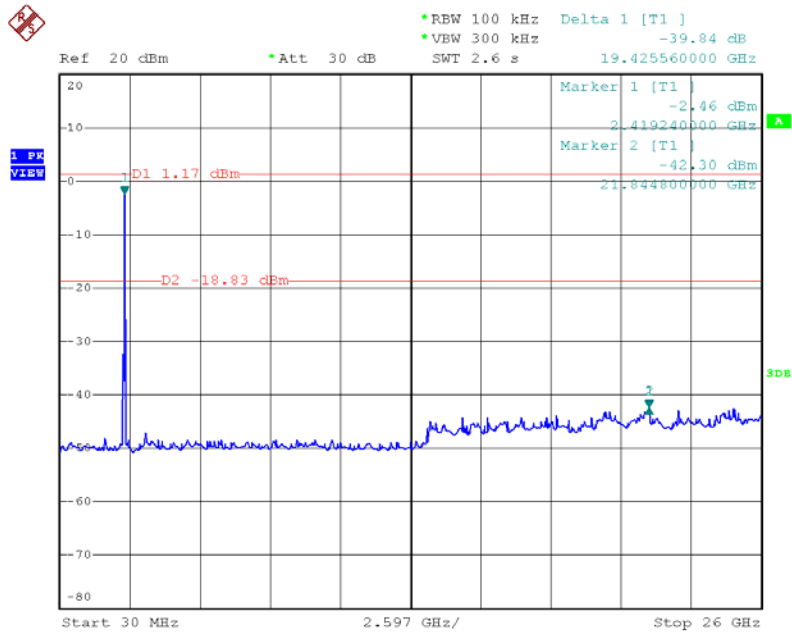

Date: 4.SEP.2012 14:50:02

Plot on Configuration IEEE 802.11n MCS0 40MHz / Ant. 1 + Ant. 2 / 2452 MHz (down 20dBc)

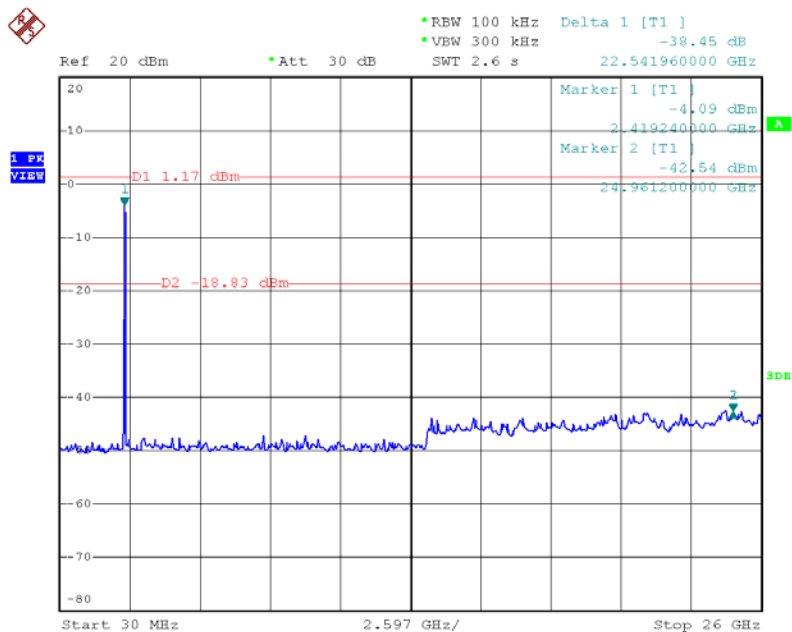

Date: 4.SEP.2012 14:51:20

### Plot on Configuration IEEE 802.11b (Reference Level)

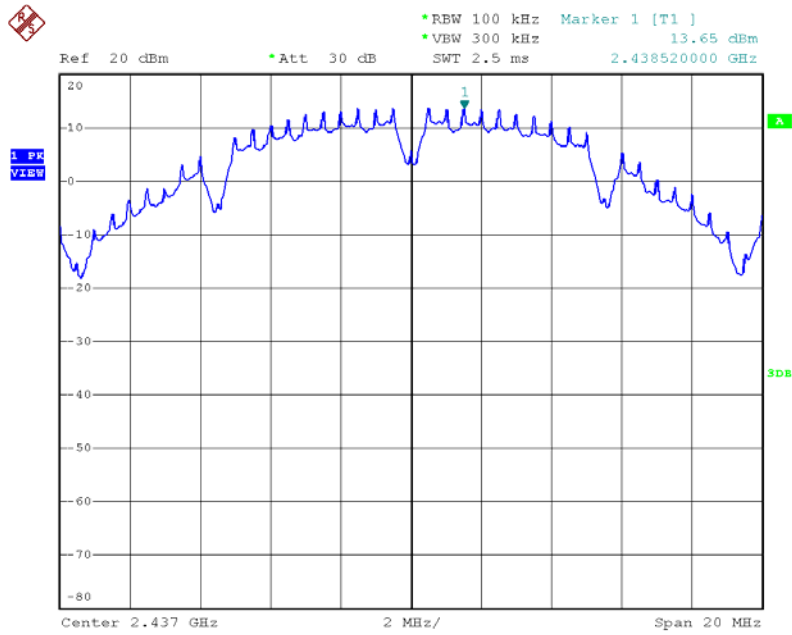

Date: 4.SEP.2012 13:30:18

### Plot on Configuration IEEE 802.11b / Ant. 1 / 2412 MHz (down 20dBc)

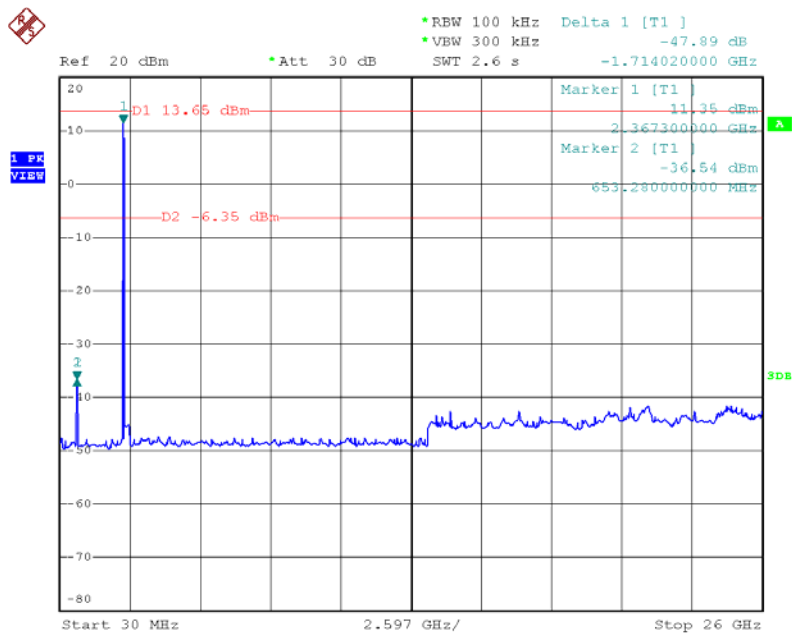

Date: 4.SEP.2012 13:37:09

Plot on Configuration IEEE 802.11b / Ant. 1 / 2437 MHz (down 20dBc)

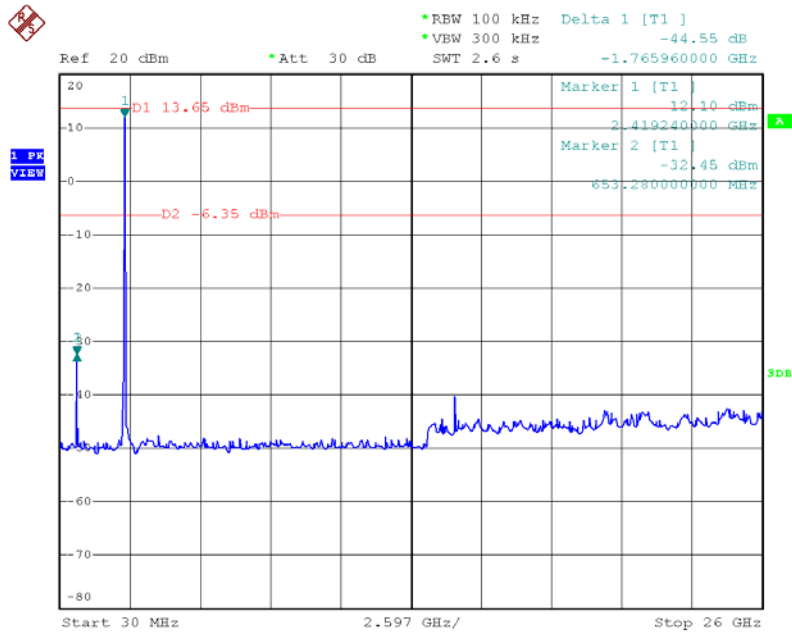

Date: 4.SEP.2012 13:31:24

Plot on Configuration IEEE 802.11b / Ant. 1 / 2462 MHz (down 20dBc)

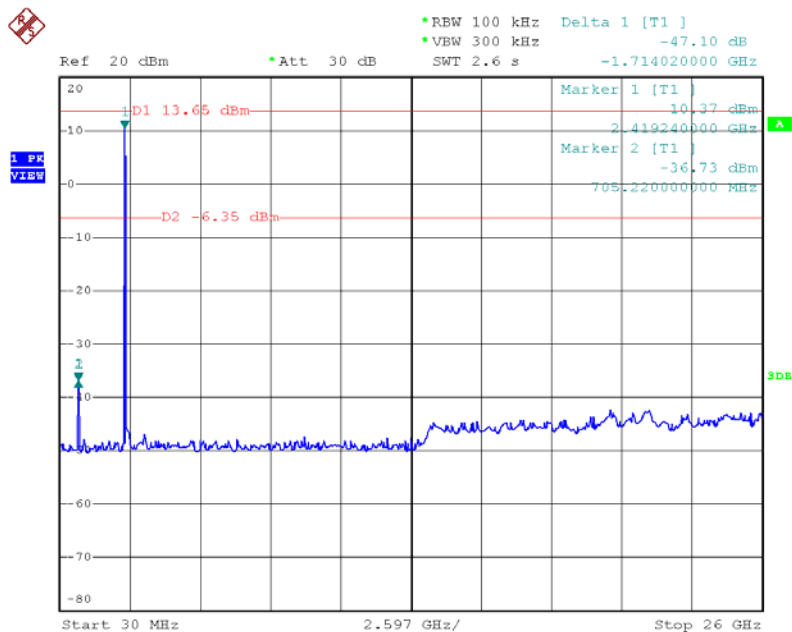

Date: 4.SEP.2012 13:38:43

Plot on Configuration IEEE 802.11g (Reference Level)

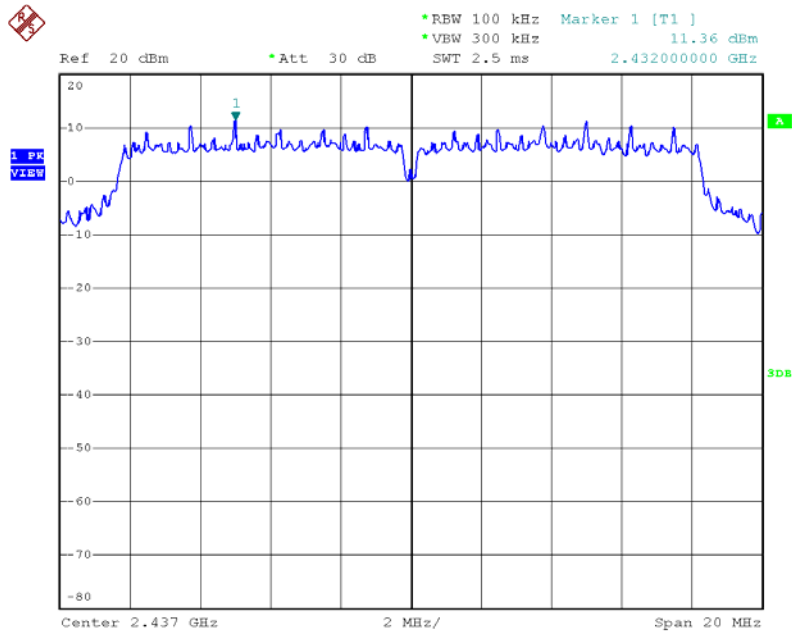

Date: 4.SEP.2012 14:07:42

Plot on Configuration IEEE 802.11g / Ant. 1 + Ant. 2 / 2412 MHz (down 20dBc)

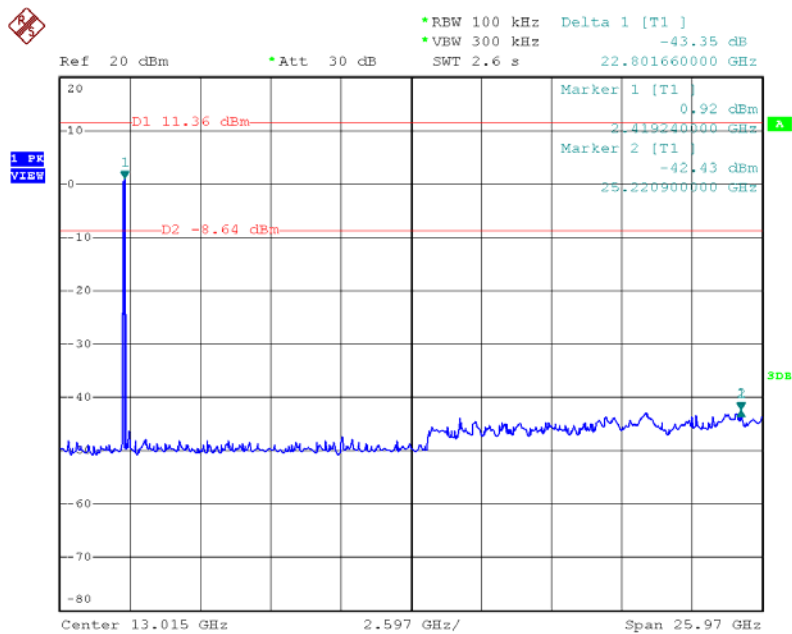

Date: 4.SEP.2012 14:11:15

Plot on Configuration IEEE 802.11g / Ant. 1+ Ant. 2 / 2437 MHz (down 20dBc)

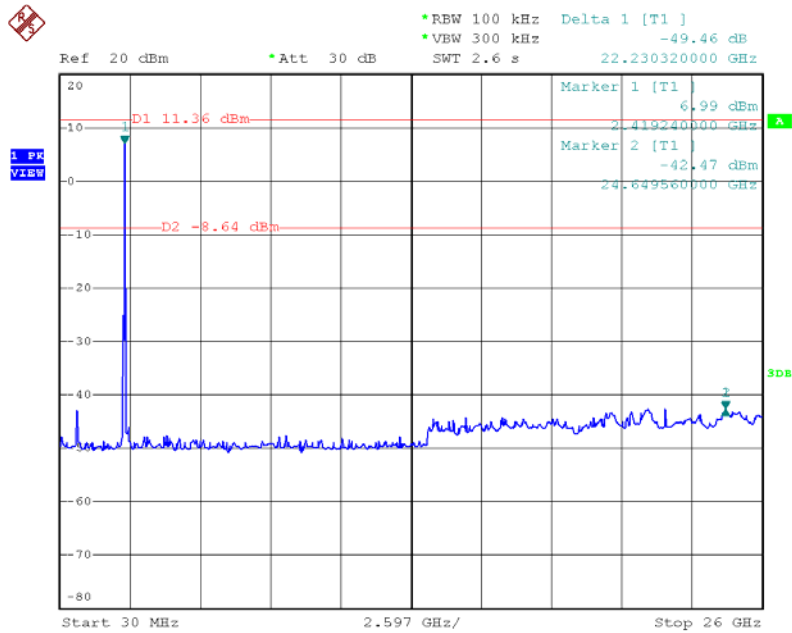

Date: 4.SEP.2012 14:09:59

Plot on Configuration IEEE 802.11g / Ant. 1+ Ant. 2 / 2462 MHz (down 20dBc)

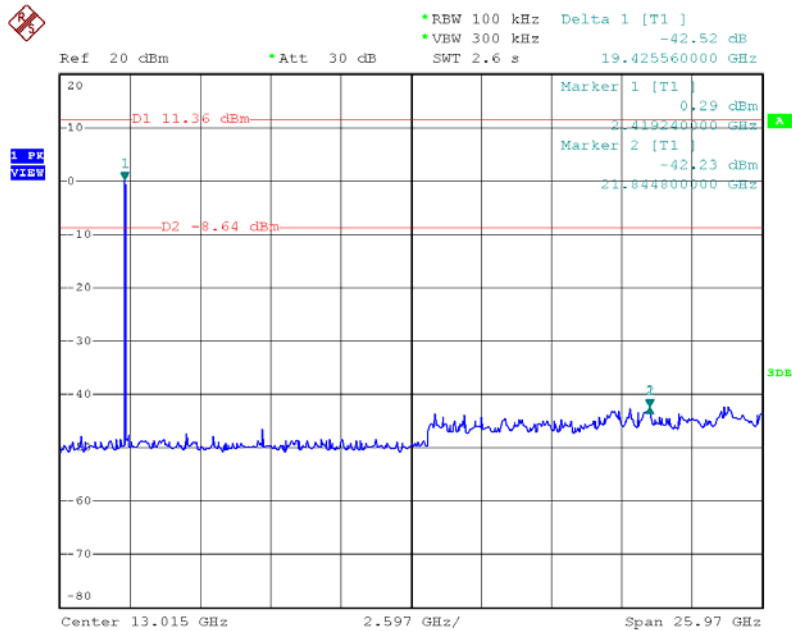

Date: 4.SEP.2012 14:12:45

## 4.8. Antenna Requirements

### 4.8.1. Limit

Except for special regulations, the Low-power Radio-frequency Devices must not be equipped with any jacket for installing an antenna with extension cable. An intentional radiator shall be designed to ensure that no antenna other than that furnished by the responsible party shall be used with the device. The use of a permanently attached antenna or of an antenna that uses a unique coupling to the intentional radiator shall be considered sufficient to comply with the provisions of this Section. The manufacturer may design the unit so that the user can replace a broken antenna, but the use of a standard antenna jack or electrical connector is prohibited. Further, this requirement does not apply to intentional radiators that must be professionally installed.

### 4.8.2. Antenna Connector Construction

Please refer to section 3.3 in this test report; antenna connector complied with the requirements.



## 5. LIST OF MEASURING EQUIPMENTS

Instrument	Manufacturer	Model No.	Serial No.	Characteristics	Calibration Date	Remark
EMI Test Receiver	R&S	ESCS 30	100377	9kHz ~ 2.75GHz	Sep. 14, 2011	Conduction (CO01-CB)
LISN	F.C.C.	FCC-LISN-50-16-2	04083	150kHz ~ 100MHz	Nov. 14, 2011	Conduction (CO01-CB)
V- LISN	Schwarzbeck	NSLK 8127	8127-478	9K ~ 30MHz	Jun. 22, 2012	Conduction (CO01-CB)
PULSE LIMITER	R&S	ESH3-Z2	100430	9K-30MHz	Feb. 03, 2012	Conduction (CO01-CB)
COND Cable	Woken	Cable	01	0.15MHz~30MHz	Dec. 4, 2011	Conduction (CO01-CB)
BILOG ANTENNA	Schaffner	CBL6112D	22021	20MHz ~ 2GHz	Jan. 11, 2012	Radiation (03CH01-CB)
Horn Antenna	EMCO	3115	00075790	750MHz~18GHz	Nov. 25, 2011	Radiation (03CH01-CB)
Horn Antenna	SCHWARZBEAK	BBHA 9170	BBHA9170252	15GHz ~ 40GHz	Nov. 22, 2011	Radiation (03CH01-CB)
Pre-Amplifier	Agilent	8447D	2944A10991	0.1MHz ~ 1.3GHz	Nov. 17, 2011	Radiation (03CH01-CB)
Pre-Amplifier	Agilent	8449B	3008A02310	1GHz ~ 26.5GHz	Nov. 29, 2011	Radiation (03CH01-CB)
Pre-Amplifier	WM	TF-130N-R1	923365	26.5GHz ~ 40GHz	Jul. 31, 2012	Radiation (03CH01-CB)
Spectrum analyzer	R&S	FSP40	100056	9KHz~40GHz	Nov. 03, 2011	Radiation (05CH01-CB)
EMI Test Receiver	R&S	ESCS 30	100355	9KHz ~ 2.75GHz	Mar. 20, 2012	Radiation (03CH01-CB)
Loop Antenna	Teseq	HLA 6120	24155	9 kHz - 30 MHz	Sep. 09, 2011	Radiation (03CH01-CB)
Turn Table	INN CO	CO 2000	N/A	0 ~ 360 degree	N/A	Radiation (03CH01-CB)
Antenna Mast	INN CO	CO2000	N/A	1 m - 4 m	N/A	Radiation (03CH01-CB)
RF Cable-low	Woken	Low Cable-1	N/A	30 MHz - 1 GHz	Nov. 17, 2011	Radiation (03CH01-CB)
RF Cable-high	Woken	High Cable-1	N/A	1 GHz – 26.5 GHz	Nov. 17, 2011	Radiation (03CH01-CB)
RF Cable-high	Woken	High Cable-2	N/A	1 GHz – 26.5 GHz	Nov. 17, 2011	Radiation (03CH01-CB)
RF Cable-high	Woken	High Cable-3	N/A	1 GHz - 40 GHz	Nov. 17, 2011	Radiation (03CH01-CB)
RF Cable-high	Woken	High Cable-4	N/A	1 GHz - 40 GHz	Nov. 17, 2011	Radiation (03CH01-CB)
Signal analyzer	R&S	FSV40	100979	9KHz~40GHz	Sep. 26, 2011	Conducted (TH01-CB)
Temp. and Humidity Chamber	Ten Billion	TTH-D3SP	TBN-931011	-30~100 degree	Jun. 05, 2012	Conducted (TH01-CB)
Thermo-Hygro Meter	N/A	HC 520	#1	15~70 degree	Nov. 02, 2010	Conducted (TH01-CB)
Signal Generator	R&S	SMR40	100302	10MHz-40GHz	Nov. 22, 2011	Conducted (TH01-CB)
RF Power Divider	HP	11636A	00306	2GHz ~ 18GHz	N/A	Conducted (TH01-CB)
RF Power Splitter	Anaren	44100	1839	2GHz ~ 18GHz	N/A	Conducted (TH01-CB)
RF Power Splitter	Anaren	42100	17930	2GHz ~ 18GHz	N/A	Conducted (TH01-CB)
Signal generator	R&S	SMU200A	102782	10MHz-40GHz	Jun. 07, 2012	Conducted (TH01-CB)
Horn Antenna	COM-POWER	AH-118	071187	1GHz – 18GHz	May. 09, 2012	Conducted (TH01-CB)
Horn Antenna	COM-POWER	AH-118	071042	1GHz – 18GHz	Nov. 01, 2011	Radiation (05CH01-CB)
RF Cable-high	Woken	High Cable-7	-	1 GHz – 26.5 GHz	Nov. 17, 2011	Conducted (TH01-CB)

Instrument	Manufacturer	Model No.	Serial No.	Characteristics	Calibration Date	Remark
RF Cable-high	Woken	High Cable-8	-	1 GHz – 26.5 GHz	Nov. 17, 2011	Conducted (TH01-CB)
RF Cable-high	Woken	High Cable-9	-	1 GHz – 26.5 GHz	Nov. 17, 2011	Conducted (TH01-CB)
RF Cable-high	Woken	High Cable-10	-	1 GHz – 26.5 GHz	Nov. 17, 2011	Conducted (TH01-CB)
RF Cable-high	Woken	High Cable-11	-	1 GHz – 26.5 GHz	Nov. 17, 2011	Conducted (TH01-CB)
RF Cable-high	Woken	High Cable-12	-	1 GHz – 26.5 GHz	Nov. 17, 2011	Conducted (TH01-CB)
RF Cable-high	Woken	High Cable-13	-	1 GHz – 26.5 GHz	Nov. 17, 2011	Conducted (TH01-CB)
Power Sensor	Anritsu	MA2411B	0917223	300MHz~40GHz	Nov. 01, 2011	Conducted (TH01-CB)
Power Meter	Anritsu	ML2495A	1035008	300MHz~40GHz	Nov. 01, 2011	Conducted (TH01-CB)

Note: Calibration Interval of instruments listed above is one year.

Note: "\*" Calibration Interval of instruments listed above is two years.

## 6. TEST LOCATION

SHIJR	ADD : 6Fl., No. 106, Sec. 1, Shintai 5th Rd., Shijr City, Taipei, Taiwan 221, R.O.C. TEL : 886-2-2696-2468 FAX : 886-2-2696-2255
HWA YA	ADD : No. 52, Hwa Ya 1st Rd., Kwei-Shan Hsiang, Tao Yuan Hsien, Taiwan, R.O.C. TEL : 886-3-327-3456 FAX : 886-3-318-0055
LINKOU	ADD : No. 30-2, Dingfu Tsuen, Linkou Shiang, Taipei, Taiwan 244, R.O.C TEL : 886-2-2601-1640 FAX : 886-2-2601-1695
DUNGHU	ADD : No. 3, Lane 238, Kangle St., Neihu Chiu, Taipei, Taiwan 114, R.O.C. TEL : 886-2-2631-4739 FAX : 886-2-2631-9740
JUNGHE	ADD : 7Fl., No. 758, Jungjeng Rd., Junghe City, Taipei, Taiwan 235, R.O.C. TEL : 886-2-8227-2020 FAX : 886-2-8227-2626
NEIHU	ADD : 4Fl., No. 339, Hsin Hu 2 <sup>nd</sup> Rd., Taipei 114, Taiwan, R.O.C. TEL : 886-2-2794-8886 FAX : 886-2-2794-9777
JHUBEI	ADD : No.8, Lane 724, Bo-ai St., Jhubei City, HsinChu County 302, Taiwan, R.O.C. TEL : 886-3-656-9065 FAX : 886-3-656-9085

## 7. TAF CERTIFICATE OF ACCREDITATION



Certificate No. : L1190-110702

財團法人全國認證基金會  
Taiwan Accreditation Foundation

### Certificate of Accreditation

This is to certify that

**Sporton International Inc.**  
**EMC & Wireless Communications Laboratory**  
No.52, Hwa Ya 1st Road, Hwa Ya Technology Park, Kwei-Shan Hsiang, Tao Yuan Hsien,  
Taiwan, R.O.C.

**is accredited in respect of laboratory**

<b>Accreditation Criteria</b>	: ISO/IEC 17025:2005
<b>Accreditation Number</b>	: 1190
<b>Originally Accredited</b>	: December 15, 2003
<b>Effective Period</b>	: January 10, 2010 to January 09, 2013
<b>Accredited Scope</b>	: Testing Field, see described in the Appendix
<b>Specific Accreditation Program</b>	: Accreditation Program for Designated Testing Laboratory for Commodities Inspection Accreditation Program for Telecommunication Equipment Testing Laboratory Accreditation Program for BSMI Mutual Recognition Arrangement with Foreign Authorities

  
Jay-San Chen  
President, Taiwan Accreditation Foundation  
Date : July 02, 2011

P1, total 22 pages

The Appendix forms an integral part of this Certificate, which shall be invalid when use without the Appendix