

## FCC Test Report

**Report No.:** RF120420C08M

**FCC ID:** PY312100187

**Test Model:** WNDR4300

**Received Date:** Apr. 20, 2012

**Test Date:** May 04 ~ May 23, 2012 (All tests except radiated emission below 1GHz and conducted emission tests)

Aug. 31 ~ Oct. 14, 2015 (Radiated emission below 1GHz and conducted emission tests)

**Issued Date:** Dec. 24, 2015

**Applicant:** NETGEAR, INC.

**Address:** 350 East Plumeria Drive San Jose, CA 95134

**Issued By:** Bureau Veritas Consumer Products Services (H.K.) Ltd., Taoyuan Branch

**Lab Address:** No. 47-2, 14th Ling, Chia Pau Vil., Lin Kou Dist., New Taipei City, Taiwan, R.O.C.

**Lab Address:** No.19, Hwa Ya 2nd Rd., Wen Hwa Vil., Kwei Shan Dist., Taoyuan City 33383, TAIWAN (R.O.C.)



This report is for your exclusive use. Any copying or replication of this report to or for any other person or entity, or use of our name or trademark, is permitted only with our prior written permission. This report sets forth our findings solely with respect to the test samples identified herein. The results set forth in this report are not indicative or representative of the quality or characteristics of the lot from which a test sample was taken or any similar or identical product unless specifically and expressly noted. Our report includes all of the tests requested by you and the results thereof based upon the information that you provided to us. You have 60 days from date of issuance of this report to notify us of any material error or omission caused by our negligence, provided, however, that such notice shall be in writing and shall specifically address the issue you wish to raise. A failure to raise such issue within the prescribed time shall constitute your unqualified acceptance of the completeness of this report, the tests conducted and the correctness of the report contents. Unless specific mention, the uncertainty of measurement has been explicitly taken into account to declare the compliance or non-compliance to the specification. The report must not be used by the client to claim product certification, approval, or endorsement by TAF or any government agencies.



## Table of Contents

<b>Release Control Record</b> .....	<b>4</b>
<b>1 Certificate of Conformity</b> .....	<b>5</b>
<b>2 Summary of Test Results</b> .....	<b>6</b>
2.1 Measurement Uncertainty.....	6
2.2 Modification Record.....	6
<b>3 General Information</b> .....	<b>7</b>
3.1 General Description of EUT.....	7
3.2 Description of Test Modes.....	9
3.2.1 Test Mode Applicability and Tested Channel Detail.....	10
3.3 Duty Cycle of Test Signal.....	12
3.4 Description of Support Units.....	13
3.4.1 Configuration of System under Test.....	14
3.5 General Description of Applied Standards.....	15
<b>4 Test Types and Results</b> .....	<b>16</b>
4.1 Radiated Emission and Bandedge Measurement.....	16
4.1.1 Limits of Radiated Emission and Bandedge Measurement.....	16
4.1.2 Test Instruments.....	17
4.1.3 Test Procedures.....	19
4.1.4 Deviation from Test Standard.....	19
4.1.5 Test Set Up.....	20
4.1.6 EUT Operating Conditions.....	20
4.1.7 Test Results.....	21
4.2 Conducted Emission Measurement.....	31
4.2.1 Limits of Conducted Emission Measurement.....	31
4.2.2 Test Instruments.....	31
4.2.3 Test Procedures.....	32
4.2.4 Deviation from Test Standard.....	32
4.2.5 Test Setup.....	32
4.2.6 EUT Operating Conditions.....	32
4.2.7 Test Results.....	33
4.3 Transmit Power Measurement.....	37
4.3.1 Limits of Transmit Power Measurement.....	37
4.3.2 Test Setup.....	37
4.3.3 Test Instruments.....	37
4.3.4 Test Procedure.....	38
4.3.5 Deviation from Test Standard.....	38
4.3.6 EUT Operating Conditions.....	38
4.3.7 Test Result.....	39
4.4 Peak Power Spectral Density Measurement.....	44
4.4.1 Limits of Peak Power Spectral Density Measurement.....	44
4.4.2 Test Setup.....	44
4.4.3 Test Instruments.....	44
4.4.4 Test Procedures.....	44
4.4.5 Deviation from Test Standard.....	45
4.4.6 EUT Operating Conditions.....	45
4.4.7 Test Results.....	46
4.5 Frequency Stability.....	48
4.5.1 Limits of Frequency Stability Measurement.....	48
4.5.2 Test Setup.....	48
4.5.3 Test Instruments.....	48
4.5.4 Test Procedure.....	48
4.5.5 Deviation from Test Standard.....	48
4.5.6 EUT Operating Condition.....	48



4.5.7 Test Results ..... 49

**5 Pictures of Test Arrangements..... 50**

**Appendix – Information on the Testing Laboratories ..... 51**



A D T

### Release Control Record

Issue No.	Description	Date Issued
RF120420C08M	Original release	Dec. 24, 2015

## 1 Certificate of Conformity

**Product:** N750 Wireless Dual Band Gigabit Router

**Brand:** Netgear

**Test Model:** WNDR4300

**Sample Status:** Engineering Sample

**Applicant:** NETGEAR, INC.

**Test Date:** May 04 ~ May 23, 2012 (All tests except radiated emission below 1GHz and conducted emission tests)

Aug. 31 ~ Oct. 14, 2015 (Radiated emission below 1GHz and conducted emission tests)

**Standards:** 47 CFR FCC Part 15, Subpart E (Section 15.407)

ANSI C63.10:2009

The above equipment has been tested by **Bureau Veritas Consumer Products Services (H.K.) Ltd., Taoyuan Branch**, and found compliance with the requirement of the above standards. The test record, data evaluation & Equipment Under Test (EUT) configurations represented herein are true and accurate accounts of the measurements of the sample's EMC characteristics under the conditions specified in this report.

**Prepared by :**



**Date:**

Dec. 24, 2015

Ivy Lin / Specialist

**Approved by :**



**Date:**

Dec. 24, 2015

Ken Liu / Senior Manager

## 2 Summary of Test Results

47 CFR FCC Part 15, Subpart E (Section 15.407)			
FCC Clause	Test Item	Result	Remarks
15.207 15.407(b)(6)	AC Power Conducted Emissions	Pass	Meet the requirement of limit. Minimum passing margin is -10.48dB at 0.29844MHz.
15.407(b) (1/2/3/4/6)	Radiated Emissions & Band Edge Measurement	Pass	Meet the requirement of limit. Minimum passing margin is -3.1dB at 53.18MHz.
15.407(a)(1/2 /3)	Max Average Transmit Power	Pass	Meet the requirement of limit.
15.407(a)(1/2 /3)	Peak Power Spectral Density	Pass	Meet the requirement of limit.
15.407(g)	Frequency Stability	Pass	Meet the requirement of limit.
15.203	Antenna Requirement	Pass	Antenna connector is UFL not a standard connector.

### 2.1 Measurement Uncertainty

Where relevant, the following measurement uncertainty levels have been estimated for tests performed on the EUT as specified in CISPR 16-4-2:

Measurement	Frequency	Expanded Uncertainty (k=2) ( $\pm$ )
Conducted Emissions at mains ports0	150kHz ~ 30MHz	2.44 dB
Radiated Emissions up to 1 GHz	30MHz ~ 200MHz	3.59 dB
	200MHz ~1000MHz	3.60 dB
Radiated Emissions above 1 GHz	1GHz ~ 40GHz	3.36 dB

### 2.2 Modification Record

There were no modifications required for compliance.

### 3 General Information

#### 3.1 General Description of EUT

Product	N750 Wireless Dual Band Gigabit Router
Brand	Netgear
Test Model	WNDR4300
Status of EUT	Engineering Sample
Power Supply Rating	12Vdc (Adapter)
Modulation Type	64QAM, 16QAM, QPSK, BPSK for OFDM
Modulation Technology	OFDM
Transfer Rate	802.11a: 54.0/ 48.0/ 36.0/ 24.0/ 18.0/ 12.0/ 9.0/ 6.0Mbps 802.11n: up to 450Mbps
Operating Frequency	5180 ~ 5240MHz
Number of Channel	4 for 802.11a, 802.11n (HT20) 2 for 802.11n (HT40)
Output Power	36.2mW
Antenna Type	Printed antenna with 2.50dBi gain
Antenna Connector	UFL
Accessory Device	Adapter
Data Cable Supplied	N/A

**Note:**

1. This report is prepared for FCC class II permissive change.
2. This report is issued as a supplementary report of the original report no.: RF120420C08-1. The differences compared with the original design are updating standard to new rule version for U-NII-1 and adding new adapters. The EUT with new adapter had been re-tested radiated emission below 1GHz and conducted emission tests.
3. The EUT incorporates a MIMO function. Physically, the EUT provides 3 completed transmitters and 3 receivers.

Modulation Mode	TX Function
802.11a	3TX
802.11n (HT20)	3TX
802.11n (HT40)	3TX

4. The EUT consumes power from the following adapters. (New adapters are adapter 3 and 4)

Adapter 1	
Brand	NETGEAR
Model	MU30-5120250-A1
Part No.	332-10234-01
Input Power	100-240Vac, 50/60Hz, 0.8A
Output Power	12Vdc, 2.5A
Power Line	1.8m non-shielded cable without core

Adapter 2	
Brand	NETGEAR
Model	P030WF120B 11200-6LF
Part No.	332-10200-02
Input Power	100-240Vac, 50/60Hz, 1.0A
Output Power	12Vdc, 2.5A
Power Line	1.8m non-shielded cable without core

Adapter 3	
Brand	NETGEAR
Model	2ABB018F
Part No.	332-10748-01
Input Power	100-240Vac, 50/60Hz, 0.6A
Output Power	12Vdc, 1.5A
Power Line	1.8m cable without core attached on adapter

Adapter 4	
Brand	NETGEAR
Model	MU18A2120150-A1
Part No.	332-10749-01
Input Power	100-240Vac, 50/60Hz, 0.5A
Output Power	12Vdc, 1.5A
Power Line	1.8m cable without core attached on adapter



### 3.2 Description of Test Modes

#### For 5180 ~ 5240MHz

4 channels are provided for 802.11a, 802.11n (HT20):

Channel	Frequency	Channel	Frequency
36	5180 MHz	44	5220 MHz
40	5200 MHz	48	5240 MHz

2 channels are provided for 802.11n (HT40):

Channel	Frequency	Channel	Frequency
38	5190 MHz	46	5230 MHz

### 3.2.1 Test Mode Applicability and Tested Channel Detail

EUT CONFIGURE MODE	APPLICABLE TO				OPERATION MODE	DESCRIPTION
	RE≥1G	RE<1G	PLC	APCM		
A	√	-	-	√	MIMO	Adapter Model: MU30-5120250-A1
B	-	√	√	-	MIMO	Adapter Model: 2ABB018F
C	-	√	√	-	MIMO	Adapter Model: MU18A2120150-A1

Where **RE≥1G**: Radiated Emission above 1GHz & Bandedge Measurement  
**RE<1G**: Radiated Emission below 1GHz  
**PLC**: Power Line Conducted Emission  
**APCM**: Antenna Port Conducted Measurement

Note:

1. The EUT had been pre-tested on the positioned of each 3 axis. The worst case was found when positioned on **X-plane**.
2. "-" means no effect.

#### Radiated Emission Test (Above 1GHz):

- Pre-Scan has been conducted to determine the worst-case mode from all possible combinations between available modulations, data rates and antenna ports (if EUT with antenna diversity architecture).
- Following channel(s) was (were) selected for the final test as listed below.

EUT CONFIGURE MODE	MODE	FREQ. BAND (MHz)	AVAILABLE CHANNEL	TESTED CHANNEL	MODULATION TECHNOLOGY	MODULATION TYPE	DATA RATE (Mbps)
A	802.11a	5180-5240	36 to 48	36, 40, 48	OFDM	BPSK	6.0
A	802.11n (HT20)		36 to 48	36, 40, 48	OFDM	BPSK	7.2
A	802.11n (HT40)		38 to 46	38, 46	OFDM	BPSK	15.0

#### Radiated Emission Test (Below 1GHz):

- Pre-Scan has been conducted to determine the worst-case mode from all possible combinations between available modulations, data rates and antenna ports (if EUT with antenna diversity architecture).
- Following channel(s) was (were) selected for the final test as listed below.

EUT CONFIGURE MODE	MODE	FREQ. BAND (MHz)	AVAILABLE CHANNEL	TESTED CHANNEL	MODULATION TECHNOLOGY	MODULATION TYPE	DATA RATE (Mbps)
B, C	802.11n (40MHz)	5180-5240	38 to 46	46	OFDM	BPSK	15.0

#### Power Line Conducted Emission Test:

- Pre-Scan has been conducted to determine the worst-case mode from all possible combinations between available modulations, data rates and antenna ports (if EUT with antenna diversity architecture).
- Following channel(s) was (were) selected for the final test as listed below.

EUT CONFIGURE MODE	MODE	FREQ. BAND (MHz)	AVAILABLE CHANNEL	TESTED CHANNEL	MODULATION TECHNOLOGY	MODULATION TYPE	DATA RATE (Mbps)
B, C	802.11n (40MHz)	5180-5240	38 to 46	46	OFDM	BPSK	15.0

**Antenna Port Conducted Measurement:**

- This item includes all test value of each mode, but only includes spectrum plot of worst value of each mode.
- Pre-Scan has been conducted to determine the worst-case mode from all possible combinations between available modulations, data rates and antenna ports (if EUT with antenna diversity architecture).
- Following channel(s) was (were) selected for the final test as listed below.

EUT CONFIGURE MODE	MODE	FREQ. BAND (MHz)	AVAILABLE CHANNEL	TESTED CHANNEL	MODULATION TECHNOLOGY	MODULATION TYPE	DATA RATE (Mbps)
A	802.11a	5180-5240	36 to 48	36, 40, 48	OFDM	BPSK	6.0
A	802.11n (HT20)		36 to 48	36, 40, 48	OFDM	BPSK	7.2
A	802.11n (HT40)		38 to 46	38, 46	OFDM	BPSK	15.0

**Test Condition:**

APPLICABLE TO	ENVIRONMENTAL CONDITIONS	INPUT POWER	TESTED BY
RE $\geq$ 1G	24deg. C, 68%RH	120Vac, 60Hz	Chad Lee
RE $<$ 1G	28deg. C, 68%RH	120Vac, 60Hz	Scott Yang
PLC	26deg. C, 62%RH	120Vac, 60Hz	Fox Chang
APCM	24deg. C, 68%RH	120Vac, 60Hz	Mark Liao

### 3.3 Duty Cycle of Test Signal

Duty cycle of test signal is > 98 %, duty factor is not required.

802.11a: Duty cycle = 1.384/1.408 = 0.983

802.11n (HT20): Duty cycle = 1.296/1.320 = 0.982

Duty cycle of test signal is < 98 %, duty factor is required.

802.11n (HT40): Duty cycle = 648/672 = 0.964, Duty factor =  $10 * \log(1/0.964) = 0.16$

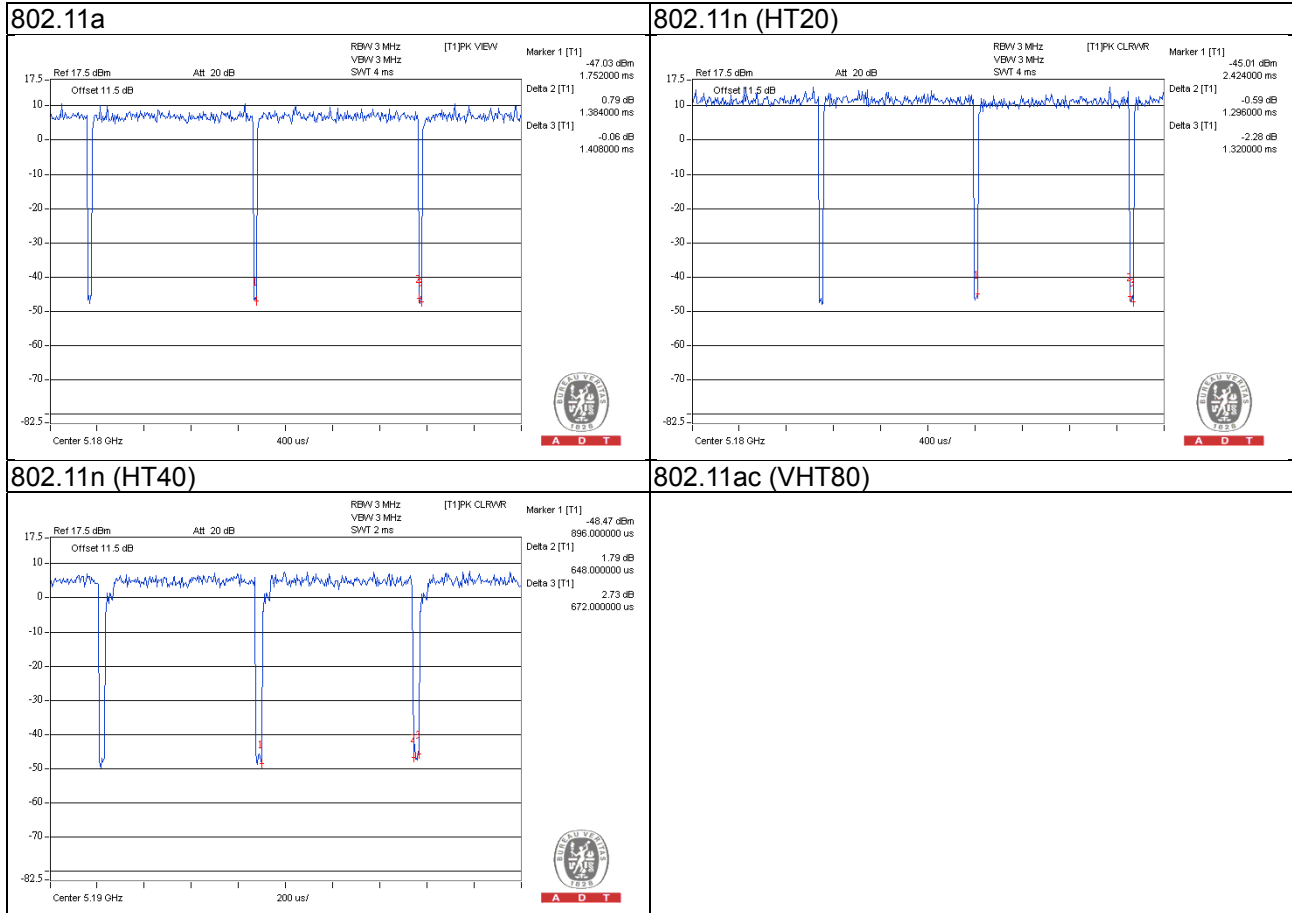

### 3.4 Description of Support Units

The EUT has been tested as an independent unit together with other necessary accessories or support units. The following support units or accessories were used to form a representative test configuration during the tests.

ID	Product	Brand	Model No.	Serial No.	FCC ID	Remarks
A.	USB Dongle	Transcend	NA	NA	NA	-
B.	Notebook	DELL	E5410	1HC2XM1	FCC DoC Approved	-
C.	Notebook	DELL	E5410	6RP2YM1	FCC DoC Approved	-
D.	Load	NA	NA	NA	NA	-
E.	Notebook	DELL	E5420	33MKMQ1	FCC DoC Approved	-
F.	Load	N/A	N/A	N/A	N/A	-
G.	USB Flash	N/A	N/A	N/A	N/A	-

Note:

1. All power cords of the above support units are non-shielded (1.8m).
2. Items B-C, E acted as communication partners to transfer data.

ID	Descriptions	Qty.	Length (m)	Shielding (Yes/No)	Cores (Qty.)	Remarks
1.	LAN Cable	1	10	N	0	Cat5e
2.	LAN Cable	1	10	N	0	Cat5e
3.	LAN Cable	3	1.8	N	0	Cat5e
4.	LAN Cable	1	10	N	0	Cat5e
5.	LAN Cable	4	1.8	N	0	Cat5e

### 3.4.1 Configuration of System under Test

Radiated emission above 1GHz test

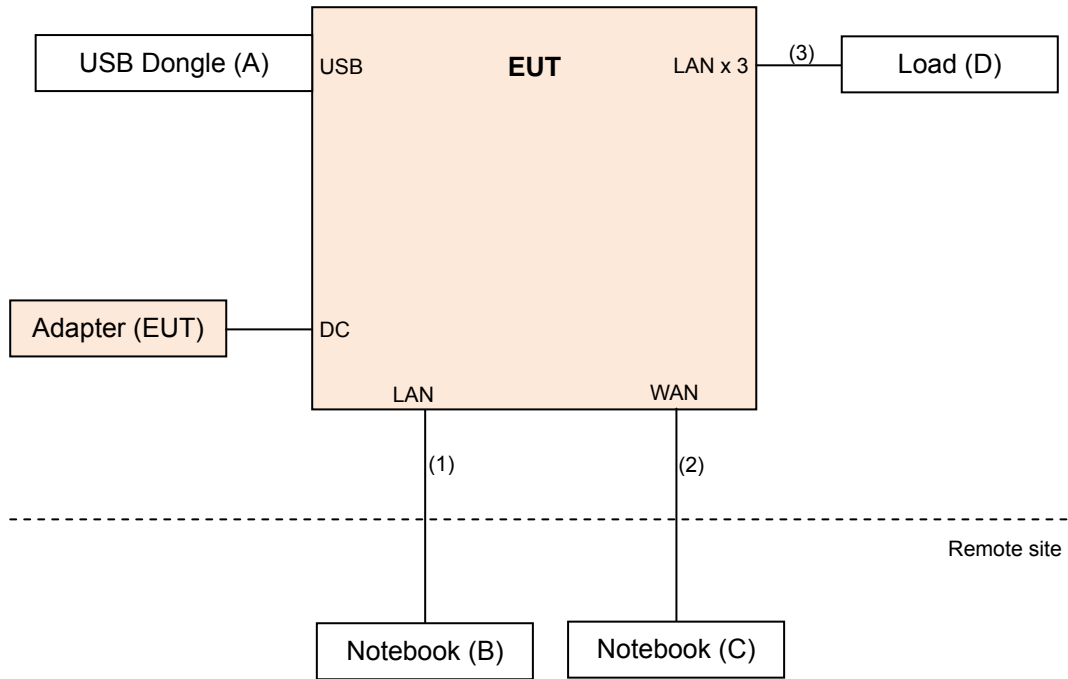

Radiated emission below 1GHz and conducted emission tests

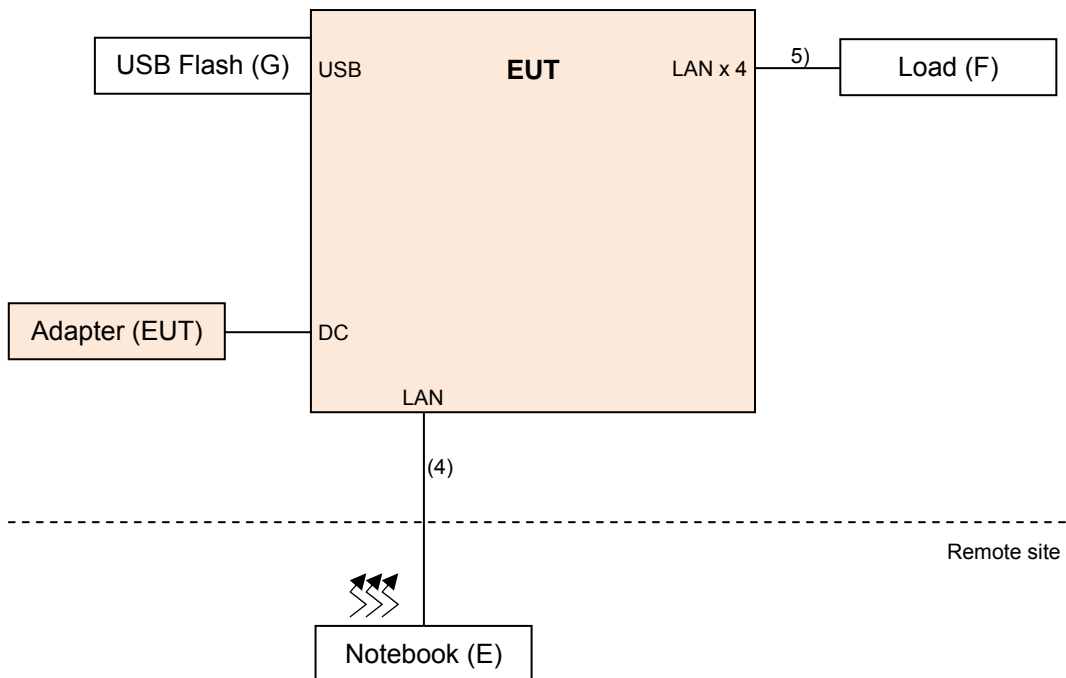

### 3.5 General Description of Applied Standards

The EUT is a RF Product. According to the specifications of the manufacturer, it must comply with the requirements of the following standards:

**FCC Part 15, Subpart E (15.407)**

**789033 D02 General UNII Test Procedures New Rules v01**

**662911 D01 Multiple Transmitter Output v02r01**

ANSI C63.10-2009

All test items have been performed and recorded as per the above standards.

Note: The EUT is also considered as a kind of computer peripheral, because the connection to computer is necessary for typical use. It has been verified to comply with the requirements of FCC Part 15, Subpart B, Class B (DoC). The test report has been issued separately.

## 4 Test Types and Results

### 4.1 Radiated Emission and Bandedge Measurement

#### 4.1.1 Limits of Radiated Emission and Bandedge Measurement

Radiated emissions which fall in the restricted bands must comply with the radiated emission limits specified as below table.

Frequencies (MHz)	Field Strength (microvolts/meter)	Measurement Distance (meters)
0.009 ~ 0.490	2400/F(kHz)	300
0.490 ~ 1.705	24000/F(kHz)	30
1.705 ~ 30.0	30	30
30 ~ 88	100	3
88 ~ 216	150	3
216 ~ 960	200	3
Above 960	500	3

**NOTE:**

1. The lower limit shall apply at the transition frequencies.
2. Emission level (dBuV/m) = 20 log Emission level (uV/m).
3. For frequencies above 1000MHz, the field strength limits are based on average detector, however, the peak field strength of any emission shall not exceed the maximum permitted average limits, specified above by more than 20dB under any condition of modulation.

#### LIMITS OF UNWANTED EMISSION OUT OF THE RESTRICTED BANDS

APPLICABLE TO	LIMIT	
789033 D02 General UNII Test Procedures New Rules v01	FIELD STRENGTH AT 3m	
	PK:74 (dBµV/m)	AV:54 (dBµV/m)
APPLICABLE TO	EIRP LIMIT	EQUIVALENT FIELD STRENGTH AT 3m
15.407(b)(1)	PK:-27 (dBm/MHz)	PK:68.2(dBµV/m)
15.407(b)(2)		
15.407(b)(3)		
15.407(b)(4)	PK:-27 (dBm/MHz) <sup>*1</sup> PK:-17 (dBm/MHz) <sup>*2</sup>	PK: 68.2(dBµV/m) <sup>*1</sup> PK:78.2 (dBµV/m) <sup>*2</sup>

**NOTE:** <sup>\*1</sup> beyond 10MHz of the band edge <sup>\*2</sup> within 10 MHz of band edge

The following formula is used to convert the equipment isotropic radiated power (eirp) to field strength:

$$E = \frac{1000000 \sqrt{30P}}{3} \mu\text{V/m, where P is the eirp (Watts).}$$





A D T

#### 4.1.2 Test Instruments

Test Date: May 04 ~ May 23, 2012

Description & Manufacturer	Model No.	Serial No.	Cal. Date	Cal. Due
Agilent Preamplifier	8447D	2432A03504	Feb. 29, 2012	Feb. 28, 2013
ROHDE & SCHWARZ TEST RECEIVER	ESCI	100412	Aug. 18, 2011	Dec. 09, 2012
Schwarzbeck Antenna	VULB9168	137	Apr. 03, 2012	Apr. 02, 2013
Loop Antenna	HFH2-Z2	100070	Jan. 31, 2012	Jan. 30, 2014
ADT. Turn Table	TT100	0306	NA	NA
ADT. Tower	AT100	0306	NA	NA
Software	ADT_Radiated_V7.6.1 5.9.2	NA	NA	NA
WOKEN RF cable	8D	CABLE-CH6-02	Apr. 30, 2012	Apr. 29, 2013
Agilent Spectrum	E4446A	MY46180403	Jun. 22, 2011	Jun. 21, 2012
Agilent Preamplifier	8449B	3008A01201	Feb. 29, 2012	Feb. 28, 2013
MITEQ Preamplifier	AMF-6F-260400-33-8P	892164	Mar. 02, 2012	Mar. 01, 2013
Schwarzbeck Horn Antenna	BBHA-9170	BBHA9170190	Oct. 07, 2011	Oct. 06, 2012
Schwarzbeck Horn Antenna	BBHA-9120-D1	D130	May 18, 2012	May 17, 2013
ADT. Turn Table	TT100	0306	NA	NA
ADT. Tower	AT100	0306	NA	NA
Software	ADT_Radiated_V7.6.1 5.9.2	NA	NA	NA
SUHNER RF cable	SF102	Cable-CH6	Aug. 19, 2011	Aug. 18, 2012
High Speed Peak Power Meter	ML2495A	0842014	Apr. 28, 2012	Apr. 27, 2013
Power Sensor	MA2411B	0738404	Apr. 28, 2012	Apr. 27, 2013

- Notes:
1. The calibration interval of the above test instruments is 12 months. And the calibrations are traceable to NML/ROC and NIST/USA.
  2. The calibration interval of the loop antenna is 24 months and the calibrations are traceable to NML/ROC and NIST/USA.
  3. The test was performed in Chamber No. 6.
  4. The Industry Canada Reference No. IC 7450E-6.
  5. The VCCI Site Registration No. G-257
  6. The FCC Site Registration No. 447212.
  7. The minimum 3dB beamwidth of antenna is 30 degrees for above 1GHz test.



A D T

Test Date: Aug. 31 ~ Sep. 03, 2015

Description & Manufacturer	Model No.	Serial No.	Cal. Date	Cal. Due
Test Receiver ROHDE & SCHWARZ	ESCI	100613	Nov. 06, 2014	Nov. 10, 2015
Spectrum Analyzer ROHDE & SCHWARZ	FSP40	100040	Jul. 08, 2015	Jul. 07, 2016
BILOG Antenna SCHWARZBECK	VULB9168	9168-155	Feb. 06, 2015	Feb. 05, 2016
HORN Antenna SCHWARZBECK	BBHA 9120D	9120D-1170	Feb. 05, 2015	Feb. 04, 2016
HORN Antenna SCHWARZBECK	BBHA 9170	BBHA9170241	Feb. 09, 2015	Feb. 08, 2016
Preamplifier Agilent	8449B	3008A01960	Aug. 09, 2015	Aug. 08, 2016
Preamplifier Agilent	8447D	2944A10631	Aug. 09, 2015	Aug. 08, 2016
RF signal cable HUBER+SUHNER	SUCOFLEX 104	Cable-CH4-02(295012+ 309220)	Aug. 09, 2015	Aug. 08, 2016
RF signal cable HUBER+SUHNER	SUCOFLEX 104	Cable-CH4-03(250724)	Aug. 09, 2015	Aug. 08, 2016
Software BV ADT	ADT_Radiated_ V7.6.15.9.4	NA	NA	NA
Antenna Tower inn-co GmbH	MA 4000	010303	NA	NA
Antenna Tower Controller BV ADT	AT100	AT93021703	NA	NA
Turn Table BV ADT	TT100	TT93021703	NA	NA
Turn Table Controller BV ADT	SC100.	SC93021703	NA	NA

- Note: 1. The calibration interval of the above test instruments is 12 months and the calibrations are traceable to NML/ROC and NIST/USA.
2. The test was performed in HwaYa Chamber 4.
3. The horn antenna and preamplifier (model: 8449B) are used only for the measurement of emission frequency above 1GHz if tested.
4. The FCC Site Registration No. is 460141.
5. The IC Site Registration No. is IC7450F-4.

#### 4.1.3 Test Procedures

- a. The EUT was placed on the top of a rotating table 0.8 meters above the ground at 3 meter chamber room for test. The table was rotated 360 degrees to determine the position of the highest radiation.
- b. The EUT was set 3 meters away from the interference-receiving antenna, which was mounted on the top of a variable-height antenna tower.
- c. The height of antenna is varied from one meter to four meters above the ground to determine the maximum value of the field strength. Both horizontal and vertical polarizations of the antenna are set to make the measurement.
- d. For each suspected emission, the EUT was arranged to its worst case and then the antenna was tuned to heights from 1 meter to 4 meters and the rotatable table was turned from 0 degrees to 360 degrees to find the maximum reading.
- e. The test-receiver system was set to quasi-peak detect function and specified bandwidth with maximum hold mode when the test frequency is below 1 GHz.
- f. The test-receiver system was set to peak and average detect function and specified bandwidth with maximum hold mode when the test frequency is above 1 GHz. If the peak reading value also meets average limit, measurement with the average detector is unnecessary.

**Note:**

1. The resolution bandwidth and video bandwidth of test receiver/spectrum analyzer is 120kHz for Quasi-peak detection (QP) at frequency below 1GHz.
2. The resolution bandwidth of test receiver/spectrum analyzer is 1 MHz and the video bandwidth is 3 MHz for Peak detection (PK) at frequency above 1GHz.
3. The resolution bandwidth of test receiver/spectrum analyzer is 1MHz and the video bandwidth is 3MHz for RMS Average (Duty cycle < 98%) for Average detection (AV) at frequency above 1GHz, then the measurement results was added to a correction factor ( $10 \log(1/\text{duty cycle})$ ).
4. The resolution bandwidth of test receiver/spectrum analyzer is 1MHz and the video bandwidth is 10Hz (Duty cycle  $\geq$  98%) for Average detection (AV) at frequency above 1GHz.
5. All modes of operation were investigated and the worst-case emissions are reported.

#### 4.1.4 Deviation from Test Standard

No deviation.

#### 4.1.5 Test Set Up

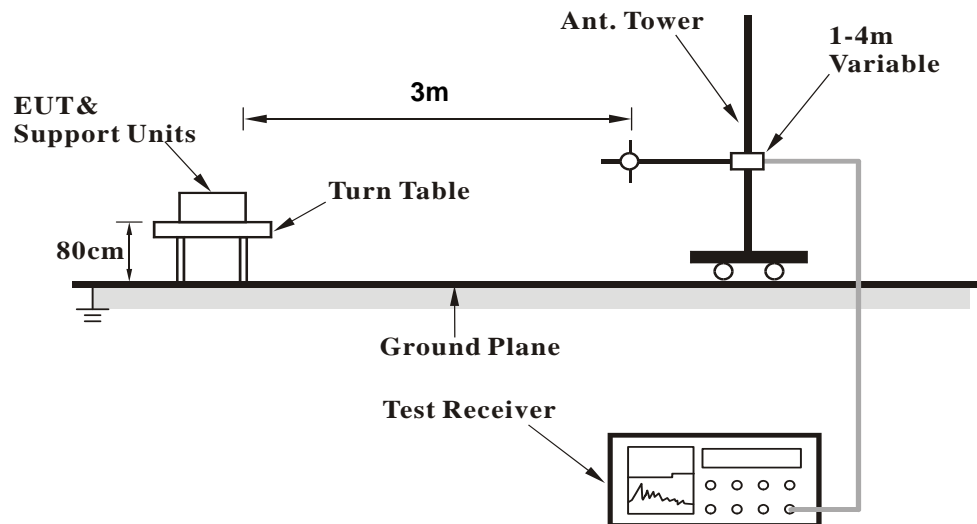

For the actual test configuration, please refer to the attached file (Test Setup Photo)

#### 4.1.6 EUT Operating Conditions

- a. Placed the EUT on the testing table.
- b. Prepared notebook to act as communication partner and placed it outside of testing area.
- c. The communication partner connected with EUT via a RJ45 cable and ran a test program (provided by manufacturer) to enable EUT under transmission condition continuously at specific channel frequency.
- d. The necessary accessories enable the system in full functions.

#### 4.1.7 Test Results

Above 1GHz Worst-Case Data:

802.11a

CHANNEL	TX Channel 36	DETECTOR FUNCTION	Peak (PK)
FREQUENCY RANGE	1GHz ~ 40GHz		Average (AV)
TEST MODE	A		

ANTENNA POLARITY & TEST DISTANCE: HORIZONTAL AT 3 M								
NO.	FREQ. (MHz)	EMISSION LEVEL (dBuV/m)	LIMIT (dBuV/m)	MARGIN (dB)	ANTENNA HEIGHT (m)	TABLE ANGLE (Degree)	RAW VALUE (dBuV)	CORRECTION FACTOR (dB/m)
1	5150.00	45.3 PK	74.0	-28.7	1.13 H	20	7.89	37.37
2	5150.00	36.2 AV	54.0	-17.8	1.13 H	20	-1.19	37.37
3	*5180.00	98.5 PK			1.13 H	20	61.07	37.41
4	*5180.00	78.1 AV			1.13 H	20	40.70	37.41
5	#10360.00	55.4 PK	68.2	-12.8	1.00 H	18	8.18	47.25
ANTENNA POLARITY & TEST DISTANCE: VERTICAL AT 3 M								
NO.	FREQ. (MHz)	EMISSION LEVEL (dBuV/m)	LIMIT (dBuV/m)	MARGIN (dB)	ANTENNA HEIGHT (m)	TABLE ANGLE (Degree)	RAW VALUE (dBuV)	CORRECTION FACTOR (dB/m)
1	5150.00	47.8 PK	74.0	-26.2	1.15 V	88	10.45	37.37
2	5150.00	34.7 AV	54.0	-19.3	1.15 V	88	-2.71	37.37
3	*5180.00	105.1 PK			1.15 V	156	67.68	37.41
4	*5180.00	85.8 AV			1.15 V	156	48.36	37.41
5	#10360.00	55.0 PK	68.2	-13.2	1.00 V	6	7.71	47.25

Remarks:

1. Emission Level(dBuV/m) = Raw Value(dBuV) + Correction Factor(dB/m)
2. Correction Factor(dB/m) = Antenna Factor(dB/m) + Cable Factor(dB)
3. The other emission levels were very low against the limit.
4. Margin value = Emission Level – Limit value
5. " \* ": Fundamental frequency.
6. " # ": The radiated frequency is out of the restricted band.

CHANNEL	TX Channel 40	DETECTOR FUNCTION	Peak (PK)
FREQUENCY RANGE	1GHz ~ 40GHz		Average (AV)
TEST MODE	A		

ANTENNA POLARITY & TEST DISTANCE: HORIZONTAL AT 3 M

NO.	FREQ. (MHz)	EMISSION LEVEL (dBuV/m)	LIMIT (dBuV/m)	MARGIN (dB)	ANTENNA HEIGHT (m)	TABLE ANGLE (Degree)	RAW VALUE (dBuV)	CORRECTION FACTOR (dB/m)
1	*5200.00	100.3 PK			1.00 H	20	62.83	37.43
2	*5200.00	80.4 AV			1.00 H	20	42.96	37.43
3	#10400.00	56.0 PK	68.2	-12.2	1.00 H	154	8.73	47.31

ANTENNA POLARITY & TEST DISTANCE: VERTICAL AT 3 M

NO.	FREQ. (MHz)	EMISSION LEVEL (dBuV/m)	LIMIT (dBuV/m)	MARGIN (dB)	ANTENNA HEIGHT (m)	TABLE ANGLE (Degree)	RAW VALUE (dBuV)	CORRECTION FACTOR (dB/m)
1	*5200.00	104.0 PK			1.00 V	86	66.57	37.43
2	*5200.00	84.3 AV			1.00 V	86	46.89	37.43
3	#10400.00	54.4 PK	68.2	-13.8	1.00 V	16	7.08	47.31

Remarks:

1. Emission Level(dBuV/m) = Raw Value(dBuV) + Correction Factor(dB/m)
2. Correction Factor(dB/m) = Antenna Factor(dB/m) + Cable Factor(dB)
3. The other emission levels were very low against the limit.
4. Margin value = Emission Level – Limit value
5. " \* ": Fundamental frequency.
6. " # ": The radiated frequency is out of the restricted band.

CHANNEL	TX Channel 48	DETECTOR FUNCTION	Peak (PK)
FREQUENCY RANGE	1GHz ~ 40GHz		Average (AV)
TEST MODE	A		

**ANTENNA POLARITY & TEST DISTANCE: HORIZONTAL AT 3 M**

NO.	FREQ. (MHz)	EMISSION LEVEL (dBuV/m)	LIMIT (dBuV/m)	MARGIN (dB)	ANTENNA HEIGHT (m)	TABLE ANGLE (Degree)	RAW VALUE (dBuV)	CORRECTION FACTOR (dB/m)
1	*5240.00	99.6 PK			1.00 H	18	62.10	37.48
2	*5240.00	79.8 AV			1.00 H	18	42.36	37.48
3	5350.00	43.2 PK	74.0	-30.8	1.00 H	18	5.55	37.62
4	5350.00	34.9 AV	54.0	-19.2	1.00 H	18	-2.77	37.62
5	#10480.00	56.5 PK	68.2	-11.7	1.00 H	6	8.96	47.49

**ANTENNA POLARITY & TEST DISTANCE: VERTICAL AT 3 M**

NO.	FREQ. (MHz)	EMISSION LEVEL (dBuV/m)	LIMIT (dBuV/m)	MARGIN (dB)	ANTENNA HEIGHT (m)	TABLE ANGLE (Degree)	RAW VALUE (dBuV)	CORRECTION FACTOR (dB/m)
1	*5240.00	105.0 PK			1.00 V	86	67.52	37.48
2	*5240.00	85.2 AV			1.00 V	86	47.69	37.48
3	5350.00	46.0 PK	74.0	-28.0	1.00 V	86	8.38	37.62
4	5350.00	33.9 AV	54.0	-20.1	1.00 V	86	-3.73	37.62
5	#10480.00	54.9 PK	68.2	-13.3	1.00 V	184	7.36	47.49

**Remarks:**

1. Emission Level(dBuV/m) = Raw Value(dBuV) + Correction Factor(dB/m)
2. Correction Factor(dB/m) = Antenna Factor(dB/m) + Cable Factor(dB)
3. The other emission levels were very low against the limit.
4. Margin value = Emission Level – Limit value
5. " \* ": Fundamental frequency.
6. " # ": The radiated frequency is out of the restricted band.

**802.11n (HT20)**

CHANNEL	TX Channel 36	DETECTOR FUNCTION	Peak (PK) Average (AV)
FREQUENCY RANGE	1GHz ~ 40GHz		
TEST MODE	A		

**ANTENNA POLARITY & TEST DISTANCE: HORIZONTAL AT 3 M**

NO.	FREQ. (MHz)	EMISSION LEVEL (dBuV/m)	LIMIT (dBuV/m)	MARGIN (dB)	ANTENNA HEIGHT (m)	TABLE ANGLE (Degree)	RAW VALUE (dBuV)	CORRECTION FACTOR (dB/m)
1	5150.00	43.5 PK	74.0	-30.5	1.00 H	15	6.11	37.37
2	5150.00	32.7 AV	54.0	-21.3	1.00 H	15	-4.68	37.37
3	*5180.00	99.9 PK			1.00 H	15	62.47	37.41
4	*5180.00	84.8 AV			1.00 H	15	47.36	37.41
5	#10360.00	54.4 PK	68.2	-13.8	1.00 H	5	7.13	47.25

**ANTENNA POLARITY & TEST DISTANCE: VERTICAL AT 3 M**

NO.	FREQ. (MHz)	EMISSION LEVEL (dBuV/m)	LIMIT (dBuV/m)	MARGIN (dB)	ANTENNA HEIGHT (m)	TABLE ANGLE (Degree)	RAW VALUE (dBuV)	CORRECTION FACTOR (dB/m)
1	5150.00	44.7 PK	74.0	-29.3	1.00 V	94	7.37	37.37
2	5150.00	34.7 AV	54.0	-19.3	1.00 V	94	-2.63	37.37
3	*5180.00	104.3 PK			1.00 V	94	66.88	37.41
4	*5180.00	89.2 AV			1.00 V	94	51.76	37.41
5	#10360.00	55.1 PK	68.2	-13.1	1.00 V	55	7.81	47.25

**Remarks:**

1. Emission Level(dBuV/m) = Raw Value(dBuV) + Correction Factor(dB/m)
2. Correction Factor(dB/m) = Antenna Factor(dB/m) + Cable Factor(dB)
3. The other emission levels were very low against the limit.
4. Margin value = Emission Level – Limit value
5. " \* ": Fundamental frequency.
6. " # ": The radiated frequency is out of the restricted band.





CHANNEL	TX Channel 40	DETECTOR FUNCTION	Peak (PK)
FREQUENCY RANGE	1GHz ~ 40GHz		Average (AV)
TEST MODE	A		

**ANTENNA POLARITY & TEST DISTANCE: HORIZONTAL AT 3 M**

NO.	FREQ. (MHz)	EMISSION LEVEL (dBuV/m)	LIMIT (dBuV/m)	MARGIN (dB)	ANTENNA HEIGHT (m)	TABLE ANGLE (Degree)	RAW VALUE (dBuV)	CORRECTION FACTOR (dB/m)
1	*5200.00	99.0 PK			1.00 H	25	61.59	37.43
2	*5200.00	86.5 AV			1.00 H	25	49.03	37.43
3	#10400.00	56.4 PK	68.2	-11.8	1.00 H	25	9.13	47.31

**ANTENNA POLARITY & TEST DISTANCE: VERTICAL AT 3 M**

NO.	FREQ. (MHz)	EMISSION LEVEL (dBuV/m)	LIMIT (dBuV/m)	MARGIN (dB)	ANTENNA HEIGHT (m)	TABLE ANGLE (Degree)	RAW VALUE (dBuV)	CORRECTION FACTOR (dB/m)
1	*5200.00	104.7 PK			1.15 V	81	67.29	37.43
2	*5200.00	92.6 AV			1.15 V	81	55.17	37.43
3	#10400.00	54.3 PK	68.2	-13.9	1.00 V	174	7.03	47.31

Remarks:

1. Emission Level(dBuV/m) = Raw Value(dBuV) + Correction Factor(dB/m)
2. Correction Factor(dB/m) = Antenna Factor(dB/m) + Cable Factor(dB)
3. The other emission levels were very low against the limit.
4. Margin value = Emission Level – Limit value
5. " \* ": Fundamental frequency.
6. " # ": The radiated frequency is out of the restricted band.

CHANNEL	TX Channel 48	DETECTOR FUNCTION	Peak (PK)
FREQUENCY RANGE	1GHz ~ 40GHz		Average (AV)
TEST MODE	A		

**ANTENNA POLARITY & TEST DISTANCE: HORIZONTAL AT 3 M**

NO.	FREQ. (MHz)	EMISSION LEVEL (dBuV/m)	LIMIT (dBuV/m)	MARGIN (dB)	ANTENNA HEIGHT (m)	TABLE ANGLE (Degree)	RAW VALUE (dBuV)	CORRECTION FACTOR (dB/m)
1	*5240.00	100.3 PK			1.00 H	15	62.77	37.48
2	*5240.00	85.3 AV			1.00 H	15	47.84	37.48
3	5350.00	44.2 PK	74.0	-29.8	1.00 H	15	6.54	37.62
4	5350.00	32.9 AV	54.0	-21.1	1.00 H	15	-4.69	37.62
5	#10480.00	56.4 PK	68.2	-11.8	1.00 H	16	8.93	47.49

**ANTENNA POLARITY & TEST DISTANCE: VERTICAL AT 3 M**

NO.	FREQ. (MHz)	EMISSION LEVEL (dBuV/m)	LIMIT (dBuV/m)	MARGIN (dB)	ANTENNA HEIGHT (m)	TABLE ANGLE (Degree)	RAW VALUE (dBuV)	CORRECTION FACTOR (dB/m)
1	*5240.00	104.0 PK			1.00 V	87	66.54	37.48
2	*5240.00	92.2 AV			1.00 V	87	54.71	37.48
3	5350.00	44.9 PK	74.0	-29.1	1.00 V	87	7.27	37.62
4	5350.00	34.8 AV	54.0	-19.2	1.00 V	87	-2.84	37.62
5	#10480.00	55.2 PK	68.2	-13.0	1.00 V	7	7.67	47.49

**Remarks:**

1. Emission Level(dBuV/m) = Raw Value(dBuV) + Correction Factor(dB/m)
2. Correction Factor(dB/m) = Antenna Factor(dB/m) + Cable Factor(dB)
3. The other emission levels were very low against the limit.
4. Margin value = Emission Level – Limit value
5. " \* ": Fundamental frequency.
6. " # ": The radiated frequency is out of the restricted band.

**802.11n (HT40)**

CHANNEL	TX Channel 38	DETECTOR FUNCTION	Peak (PK) Average (AV)
FREQUENCY RANGE	1GHz ~ 40GHz		
TEST MODE	A		

**ANTENNA POLARITY & TEST DISTANCE: HORIZONTAL AT 3 M**

NO.	FREQ. (MHz)	EMISSION LEVEL (dBuV/m)	LIMIT (dBuV/m)	MARGIN (dB)	ANTENNA HEIGHT (m)	TABLE ANGLE (Degree)	RAW VALUE (dBuV)	CORRECTION FACTOR (dB/m)
1	5150.00	44.1 PK	74.0	-29.9	1.14 H	11	6.72	37.37
2	5150.00	32.7 AV	54.0	-21.3	1.14 H	11	-4.63	37.37
3	*5190.00	100.8 PK			1.14 H	11	63.36	37.42
4	*5190.00	86.6 AV			1.14 H	11	49.14	37.42
5	#10380.00	55.4 PK	68.2	-12.8	1.00 H	6	8.13	47.28

**ANTENNA POLARITY & TEST DISTANCE: VERTICAL AT 3 M**

NO.	FREQ. (MHz)	EMISSION LEVEL (dBuV/m)	LIMIT (dBuV/m)	MARGIN (dB)	ANTENNA HEIGHT (m)	TABLE ANGLE (Degree)	RAW VALUE (dBuV)	CORRECTION FACTOR (dB/m)
1	5150.00	45.4 PK	74.0	-28.6	1.18 V	81	8.04	37.37
2	5150.00	34.1 AV	54.0	-19.9	1.18 V	81	-3.28	37.37
3	*5190.00	104.6 PK			1.18 V	81	67.13	37.42
4	*5190.00	90.6 AV			1.18 V	81	53.14	37.42
5	#10380.00	54.4 PK	68.2	-13.8	1.00 V	172	7.07	47.28

**Remarks:**

1. Emission Level(dBuV/m) = Raw Value(dBuV) + Correction Factor(dB/m)
2. Correction Factor(dB/m) = Antenna Factor(dB/m) + Cable Factor(dB)
3. The other emission levels were very low against the limit.
4. Margin value = Emission Level – Limit value
5. " \* ": Fundamental frequency.
6. " # ": The radiated frequency is out of the restricted band.

CHANNEL	TX Channel 46	DETECTOR FUNCTION	Peak (PK)
FREQUENCY RANGE	1GHz ~ 40GHz		Average (AV)
TEST MODE	A		

**ANTENNA POLARITY & TEST DISTANCE: HORIZONTAL AT 3 M**

NO.	FREQ. (MHz)	EMISSION LEVEL (dBuV/m)	LIMIT (dBuV/m)	MARGIN (dB)	ANTENNA HEIGHT (m)	TABLE ANGLE (Degree)	RAW VALUE (dBuV)	CORRECTION FACTOR (dB/m)
1	*5230.00	100.8 PK			1.00 H	17	63.29	37.47
2	*5230.00	86.8 AV			1.00 H	17	49.28	37.47
3	5350.00	43.9 PK	74.0	-30.2	1.00 H	17	6.23	37.62
4	5350.00	33.0 AV	54.0	-21.0	1.00 H	17	-4.65	37.62
5	#10460.00	56.1 PK	68.2	-12.1	1.00 H	7	8.62	47.44

**ANTENNA POLARITY & TEST DISTANCE: VERTICAL AT 3 M**

NO.	FREQ. (MHz)	EMISSION LEVEL (dBuV/m)	LIMIT (dBuV/m)	MARGIN (dB)	ANTENNA HEIGHT (m)	TABLE ANGLE (Degree)	RAW VALUE (dBuV)	CORRECTION FACTOR (dB/m)
1	*5230.00	104.2 PK			1.16 V	86	66.69	37.47
2	*5230.00	89.9 AV			1.16 V	86	52.42	37.47
3	5350.00	45.4 PK	74.0	-28.6	1.16 V	86	7.79	37.62
4	5350.00	33.9 AV	54.0	-20.1	1.16 V	86	-3.73	37.62
5	#10460.00	55.8 PK	68.2	-12.4	1.00 V	19	8.34	47.44

**Remarks:**

1. Emission Level(dBuV/m) = Raw Value(dBuV) + Correction Factor(dB/m)
2. Correction Factor(dB/m) = Antenna Factor(dB/m) + Cable Factor(dB)
3. The other emission levels were very low against the limit.
4. Margin value = Emission Level – Limit value
5. " \* ": Fundamental frequency.
6. " # ": The radiated frequency is out of the restricted band.

Below 1GHz Worst-Case Data: 802.11n (40MHz)

CHANNEL	TX Channel 46	DETECTOR FUNCTION	Quasi-Peak (QP)
FREQUENCY RANGE	30MHz ~ 1GHz		
TEST MODE	B		

ANTENNA POLARITY & TEST DISTANCE: HORIZONTAL AT 3 M

NO.	FREQ. (MHz)	EMISSION LEVEL (dBuV/m)	LIMIT (dBuV/m)	MARGIN (dB)	ANTENNA HEIGHT (m)	TABLE ANGLE (Degree)	RAW VALUE (dBuV)	CORRECTION FACTOR (dB/m)
1	45.52	17.6 QP	40.0	-22.4	1.51 H	350	32.10	-14.50
2	119.24	23.3 QP	43.5	-20.2	1.51 H	159	39.80	-16.50
3	200.72	23.7 QP	43.5	-19.8	1.01 H	146	40.30	-16.60
4	249.22	31.2 QP	46.0	-14.8	1.01 H	112	45.60	-14.40
5	321.00	29.7 QP	46.0	-16.3	1.01 H	160	41.50	-11.80
6	600.36	31.1 QP	46.0	-14.9	1.51 H	316	37.40	-6.30

ANTENNA POLARITY & TEST DISTANCE: VERTICAL AT 3 M

NO.	FREQ. (MHz)	EMISSION LEVEL (dBuV/m)	LIMIT (dBuV/m)	MARGIN (dB)	ANTENNA HEIGHT (m)	TABLE ANGLE (Degree)	RAW VALUE (dBuV)	CORRECTION FACTOR (dB/m)
1	45.52	29.6 QP	40.0	-10.4	1.49 V	267	44.10	-14.50
2	64.92	30.5 QP	40.0	-9.5	1.24 V	12	45.70	-15.20
3	99.84	23.8 QP	43.5	-19.7	1.24 V	216	42.50	-18.70
4	121.18	22.1 QP	43.5	-21.4	1.00 V	65	38.50	-16.40
5	249.22	25.2 QP	46.0	-20.8	1.99 V	212	39.60	-14.40
6	499.48	30.6 QP	46.0	-15.4	1.00 V	228	39.20	-8.60

REMARKS:

1. Emission Level(dBuV/m) = Raw Value(dBuV) + Correction Factor(dB/m)
2. Correction Factor(dB/m) = Antenna Factor(dB/m) + Cable Factor(dB)
3. The other emission levels were very low against the limit.
4. Margin value = Emission Level – Limit value

CHANNEL	TX Channel 46	DETECTOR FUNCTION	Quasi-Peak (QP)
FREQUENCY RANGE	30MHz ~ 1GHz		
TEST MODE	C		

**ANTENNA POLARITY & TEST DISTANCE: HORIZONTAL AT 3 M**

NO.	FREQ. (MHz)	EMISSION LEVEL (dBuV/m)	LIMIT (dBuV/m)	MARGIN (dB)	ANTENNA HEIGHT (m)	TABLE ANGLE (Degree)	RAW VALUE (dBuV)	CORRECTION FACTOR (dB/m)
1	55.13	34.8 QP	40.0	-5.2	1.24 H	12	48.80	-14.00
2	97.81	35.2 QP	43.5	-8.3	1.99 H	95	54.20	-19.00
3	124.98	37.2 QP	43.5	-6.3	1.99 H	95	53.20	-16.00
4	249.17	35.2 QP	46.0	-10.8	1.24 H	98	49.80	-14.60
5	600.38	29.6 QP	46.0	-16.4	1.50 H	21	36.50	-6.90
6	875.91	34.2 QP	46.0	-11.8	1.00 H	298	36.30	-2.10

**ANTENNA POLARITY & TEST DISTANCE: VERTICAL AT 3 M**

NO.	FREQ. (MHz)	EMISSION LEVEL (dBuV/m)	LIMIT (dBuV/m)	MARGIN (dB)	ANTENNA HEIGHT (m)	TABLE ANGLE (Degree)	RAW VALUE (dBuV)	CORRECTION FACTOR (dB/m)
<b>1</b>	<b>53.18</b>	<b>36.9 QP</b>	<b>40.0</b>	<b>-3.1</b>	<b>1.24 V</b>	<b>12</b>	<b>50.70</b>	<b>-13.80</b>
2	68.71	36.8 QP	40.0	-3.2	1.00 V	125	52.40	-15.60
3	95.87	38.3 QP	43.5	-5.2	1.00 V	163	57.40	-19.10
4	124.98	39.6 QP	43.5	-3.9	1.00 V	157	55.60	-16.00
5	249.17	34.2 QP	46.0	-11.8	2.00 V	128	48.80	-14.60
6	600.38	31.7 QP	46.0	-14.3	1.00 V	139	38.60	-6.90

**REMARKS:**

1. Emission Level(dBuV/m) = Raw Value(dBuV) + Correction Factor(dB/m)
2. Correction Factor(dB/m) = Antenna Factor(dB/m) + Cable Factor(dB)
3. The other emission levels were very low against the limit.
4. Margin value = Emission Level – Limit value

## 4.2 Conducted Emission Measurement

### 4.2.1 Limits of Conducted Emission Measurement

Frequency (MHz)	Conducted Limit (dBuV)	
	Quasi-peak	Average
0.15 - 0.5	66 - 56	56 - 46
0.50 - 5.0	56	46
5.0 - 30.0	60	50

- Note:** 1. The lower limit shall apply at the transition frequencies.  
 2. The limit decreases in line with the logarithm of the frequency in the range of 0.15 to 0.50MHz.

### 4.2.2 Test Instruments

Test Date: Oct. 14, 2015

Description & Manufacturer	Model No.	Serial No.	Cal. Date	Cal. Due
Test Receiver ROHDE & SCHWARZ	ESCS 30	100288	Apr. 27, 2015	Apr. 26, 2016
RF signal cable (with 10dB PAD) Woken	5D-FB	Cable-cond2-01	Dec. 26, 2014	Dec. 25, 2015
LISN ROHDE & SCHWARZ (EUT)	ESH2-Z5	100100	Dec. 30, 2014	Dec. 29, 2015
LISN ROHDE & SCHWARZ (Peripheral)	ESH3-Z5	100312	Jul. 21, 2015	Jul. 20, 2016
Software ADT	BV ADT_Cond_ V7.3.7.3	NA	NA	NA

- Note:** 1. The calibration interval of the above test instruments is 12 months and the calibrations are traceable to NML/ROC and NIST/USA.  
 2. The test was performed in HwaYa Shielded Room 2.  
 3. The VCCI Site Registration No. is C-2047.

#### 4.2.3 Test Procedures

- The EUT was placed 0.4 meters from the conducting wall of the shielded room with EUT being connected to the power mains through a line impedance stabilization network (LISN). Other support units were connected to the power mains through another LISN. The two LISNs provide 50 ohm/ 50uH of coupling impedance for the measuring instrument.
- Both lines of the power mains connected to the EUT were checked for maximum conducted interference.
- The frequency range from 150kHz to 30MHz was searched. Emission levels under (Limit - 20dB) was not recorded.

**NOTE:** The resolution bandwidth and video bandwidth of test receiver is 9kHz for quasi-peak detection (QP) and average detection (AV) at frequency 0.15MHz-30MHz.

#### 4.2.4 Deviation from Test Standard

No deviation.

#### 4.2.5 Test Setup

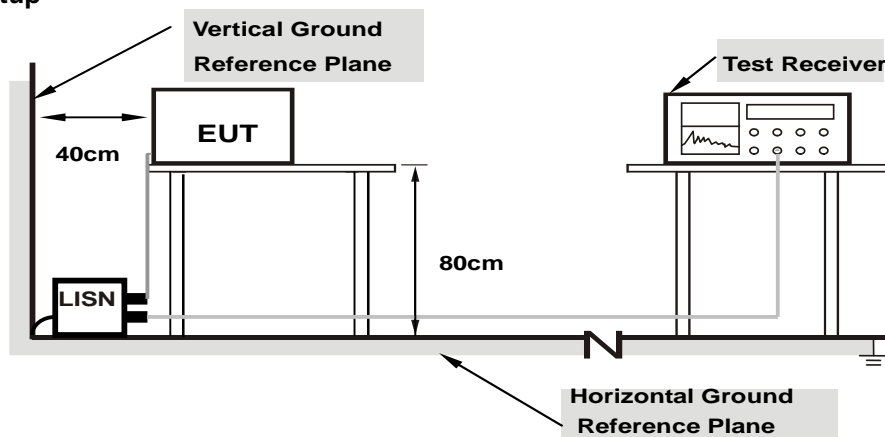

**Note:** 1.Support units were connected to second LISN.

For the actual test configuration, please refer to the attached file (Test Setup Photo).

#### 4.2.6 EUT Operating Conditions

- Placed the EUT on the testing table.
- Prepared notebook to act as communication partner and placed it outside of testing area.
- The communication partner connected with EUT via a RJ45 cable and ran a test program (provided by manufacturer) to enable EUT under transmission condition continuously at specific channel frequency.
- The necessary accessories enable the system in full functions.



### 4.2.7 Test Results

Phase	Line (L)	Detector Function	Quasi-Peak (QP) / Average (AV)
Test Mode	B		

No	Freq. [MHz]	Corr. Factor (dB)	Reading Value		Emission Level		Limit		Margin	
			[dB (uV)]		[dB (uV)]		[dB (uV)]		(dB)	
			Q.P.	AV.	Q.P.	AV.	Q.P.	AV.	Q.P.	AV.
1	0.15000	9.91	37.00	23.57	46.91	33.48	66.00	56.00	-19.09	-22.52
2	0.15781	9.91	35.56	20.79	45.47	30.70	65.58	55.58	-20.11	-24.88
3	0.17344	9.91	32.30	20.15	42.21	30.06	64.79	54.79	-22.58	-24.73
4	0.18906	9.91	31.23	21.88	41.14	31.79	64.08	54.08	-22.93	-22.28
5	0.28281	9.92	33.26	27.72	43.18	37.64	60.73	50.73	-17.55	-13.09
6	3.72656	10.17	24.23	18.76	34.40	28.93	56.00	46.00	-21.60	-17.07

**REMARKS:**

1. Q.P. and AV. are abbreviations of quasi-peak and average individually.
2. The emission levels of other frequencies were very low against the limit.
3. Margin value = Emission level - Limit value
4. Correction factor = Insertion loss + Cable loss
5. Emission Level = Correction Factor + Reading Value.

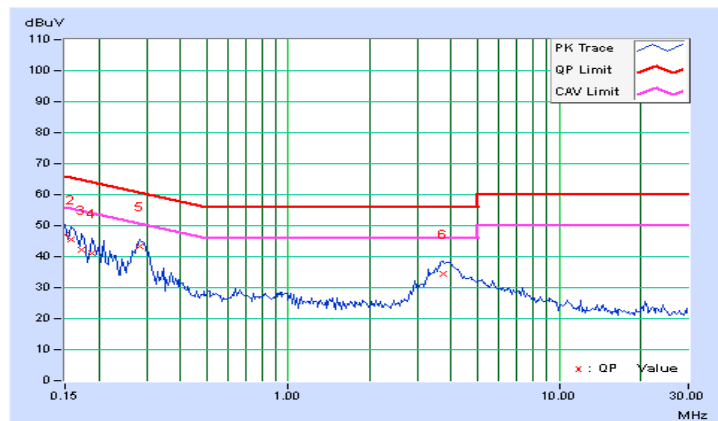

Phase	Neutral (N)	Detector Function	Quasi-Peak (QP) / Average (AV)
Test Mode	B		

No	Freq. [MHz]	Corr. Factor (dB)	Reading Value [dB (uV)]		Emission Level [dB (uV)]		Limit [dB (uV)]		Margin (dB)	
			Q.P.	AV.	Q.P.	AV.	Q.P.	AV.	Q.P.	AV.
			1	0.15391	9.92	35.66	21.19	45.58	31.11	65.79
2	0.16953	9.92	33.37	20.50	43.29	30.42	64.98	54.98	-21.69	-24.56
<b>3</b>	<b>0.29844</b>	<b>9.94</b>	<b>36.23</b>	<b>29.87</b>	<b>46.17</b>	<b>39.81</b>	<b>60.29</b>	<b>50.29</b>	<b>-14.12</b>	<b>-10.48</b>
4	0.33359	9.94	22.47	16.04	32.41	25.98	59.36	49.36	-26.95	-23.38
5	3.68359	10.20	20.62	14.94	30.82	25.14	56.00	46.00	-25.18	-20.86
6	13.56641	10.57	5.37	1.73	15.94	12.30	60.00	50.00	-44.06	-37.70

**REMARKS:**

1. Q.P. and AV. are abbreviations of quasi-peak and average individually.
2. The emission levels of other frequencies were very low against the limit.
3. Margin value = Emission level - Limit value
4. Correction factor = Insertion loss + Cable loss
5. Emission Level = Correction Factor + Reading Value.

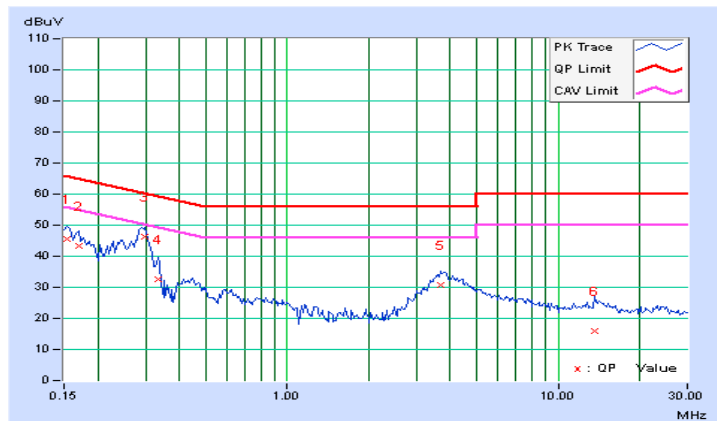

Phase	Line (L)	Detector Function	Quasi-Peak (QP) / Average (AV)
Test Mode	C		

No	Freq. [MHz]	Corr. Factor (dB)	Reading Value [dB (uV)]		Emission Level [dB (uV)]		Limit [dB (uV)]		Margin (dB)	
			Q.P.	AV.	Q.P.	AV.	Q.P.	AV.	Q.P.	AV.
			1	0.15781	9.91	42.35	26.66	52.26	36.57	65.58
2	0.16562	9.91	42.54	28.24	52.45	38.15	65.18	55.18	-12.73	-17.03
3	0.18906	9.91	39.33	24.98	49.24	34.89	64.08	54.08	-14.83	-19.18
4	0.39219	9.93	28.31	23.89	38.24	33.82	58.02	48.02	-19.78	-14.20
5	5.85156	10.25	22.36	17.67	32.61	27.92	60.00	50.00	-27.39	-22.08
6	15.18750	10.50	18.31	13.52	28.81	24.02	60.00	50.00	-31.19	-25.98

**REMARKS:**

1. Q.P. and AV. are abbreviations of quasi-peak and average individually.
2. The emission levels of other frequencies were very low against the limit.
3. Margin value = Emission level - Limit value
4. Correction factor = Insertion loss + Cable loss
5. Emission Level = Correction Factor + Reading Value.

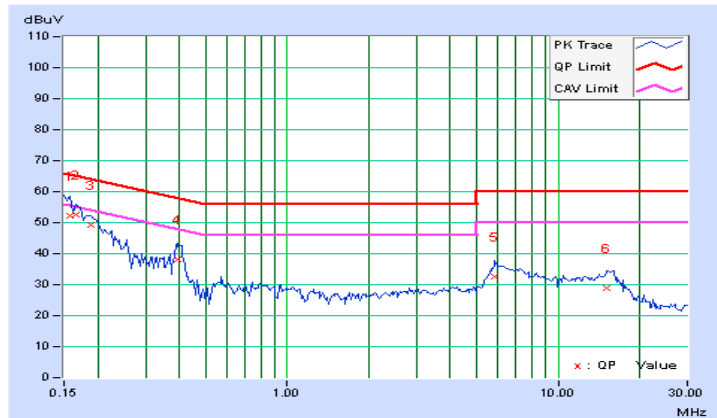

Phase	Neutral (N)	Detector Function	Quasi-Peak (QP) / Average (AV)
Test Mode	C		

No	Freq. [MHz]	Corr. Factor (dB)	Reading Value [dB (uV)]		Emission Level [dB (uV)]		Limit [dB (uV)]		Margin (dB)	
			Q.P.	AV.	Q.P.	AV.	Q.P.	AV.	Q.P.	AV.
			1	0.15391	9.92	44.26	30.18	54.18	40.10	65.79
2	0.16953	9.92	42.82	29.90	52.74	39.82	64.98	54.98	-12.24	-15.16
3	0.18906	9.92	39.15	26.18	49.07	36.10	64.08	54.08	-15.00	-17.97
4	0.39609	9.95	30.80	27.27	40.75	37.22	57.93	47.93	-17.18	-10.71
5	6.05859	10.30	18.41	13.39	28.71	23.69	60.00	50.00	-31.29	-26.31
6	11.10156	10.49	17.31	13.07	27.80	23.56	60.00	50.00	-32.20	-26.44

**REMARKS:**

1. Q.P. and AV. are abbreviations of quasi-peak and average individually.
2. The emission levels of other frequencies were very low against the limit.
3. Margin value = Emission level - Limit value
4. Correction factor = Insertion loss + Cable loss
5. Emission Level = Correction Factor + Reading Value.

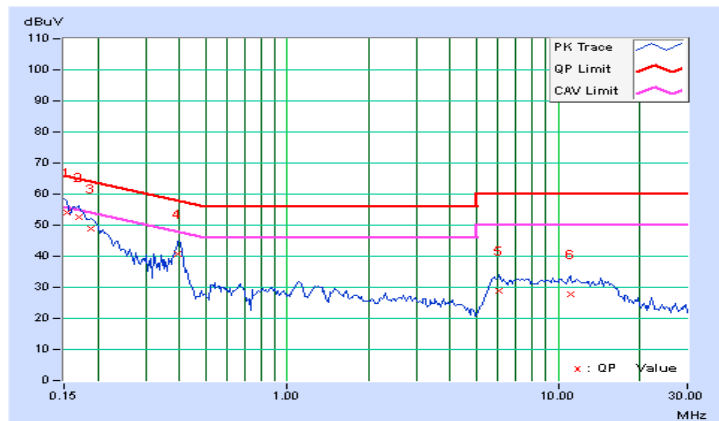

### 4.3 Transmit Power Measurement

#### 4.3.1 Limits of Transmit Power Measurement

Operation Band	EUT Category		LIMIT
U-NII-1		Outdoor Access Point	1 Watt (30 dBm) (Max. e.i.r.p 125mW(21 dBm) at any elevation angle above 30 degrees as measured from the horizon)
		Fixed point-to-point Access Point	1 Watt (30 dBm)
	√	Indoor Access Point	1 Watt (30 dBm)
		Mobile and Portable client device	250mW (24 dBm)
U-NII-2A	---		250mW (24 dBm) or 11 dBm+10 log B*
U-NII-2C	---		250mW (24 dBm) or 11 dBm+10 log B*
U-NII-3	---		1 Watt (30 dBm)

\*B is the 26 dB emission bandwidth in megahertz

Per KDB 662911 Method of conducted output power measurement on IEEE 802.11 devices,

Array Gain = 0 dB (i.e., no array gain) for  $N_{ANT} \leq 4$ ;

Array Gain = 0 dB (i.e., no array gain) for channel widths  $\geq 40$  MHz for any  $N_{ANT}$ ;

Array Gain =  $5 \log(N_{ANT}/N_{SS})$  dB or 3 dB, whichever is less for 20-MHz channel widths with  $N_{ANT} \geq 5$ .

For power measurements on all other devices: Array Gain =  $10 \log(N_{ANT}/N_{SS})$  dB.

#### 4.3.2 Test Setup

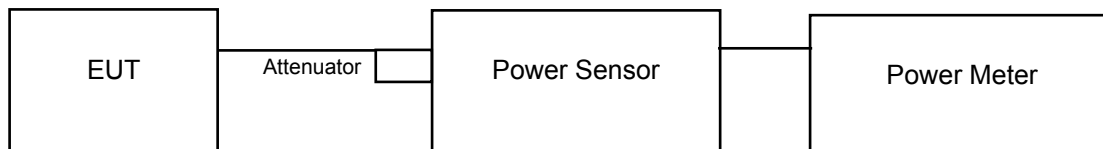

#### 4.3.3 Test Instruments

Refer to section 4.1.2 to get information of above instrument.

#### 4.3.4 Test Procedure

##### For Average Power Measurement

Method PM is used to perform output power measurement, trigger and gating function of wide band power meter is enabled to measure max output power of TX on burst. Duty factor is not added to measured value.

##### For Occupied Bandwidth

The transmitter output was connected to the spectrum analyzer through an attenuator. The bandwidth of the fundamental frequency was measured by spectrum analyzer with resolution bandwidth in the range of 1% to 5% of the anticipated emission bandwidth, and a video bandwidth at least 3x the resolution bandwidth and set the detector to AVERAGE. The width of a frequency band such that, below the lower and above the upper frequency limits, the mean powers emitted are each equal to a specified percentage 0.5 %of the total mean power of a given emission.

#### 4.3.5 Deviation from Test Standard

No deviation.

#### 4.3.6 EUT Operating Conditions

The software provided by client to enable the EUT under transmission condition continuously at lowest, middle and highest channel frequencies individually.

#### 4.3.7 Test Result

##### Power Output:

##### 802.11a

Chan.	Chan. Freq. (MHz)	Maximum Conducted Power (dBm)			Total Power (mW)	Total Power (dBm)	Power Limit (dBm)	Pass / Fail
		Chain 0	Chain 1	Chain 2				
36	5180	9.12	8.59	9.07	23.5	13.7	30.00	Pass
40	5200	9.26	8.61	9.28	24.2	13.8	30.00	Pass
48	5240	9.08	8.52	9.21	23.5	13.7	30.00	Pass

##### 802.11n (HT20)

Chan.	Chan. Freq. (MHz)	Maximum Conducted Power (dBm)			Total Power (mW)	Total Power (dBm)	Power Limit (dBm)	Pass / Fail
		Chain 0	Chain 1	Chain 2				
36	5180	9.23	8.52	9.11	23.6	13.7	30.00	Pass
40	5200	9.16	8.68	9.22	24.0	13.8	30.00	Pass
48	5240	9.15	8.61	9.46	24.3	13.9	30.00	Pass

##### 802.11n (HT40)

Chan.	Chan. Freq. (MHz)	Maximum Conducted Power (dBm)			Total Power (mW)	Total Power (dBm)	Power Limit (dBm)	Pass / Fail
		Chain 0	Chain 1	Chain 2				
38	5190	11.01	10.23	10.85	35.3	15.5	30.00	Pass
46	5230	11.06	10.32	11.04	<b>36.2</b>	15.6	30.00	Pass

**26dB Bandwidth:**
**802.11a**

Channel	Channel Frequency (MHz)	26dBc Bandwidth (MHz)			Pass / Fail
		Chain 0	Chain 1	Chain 2	
36	5180	25.09	24.49	23.97	Pass
40	5200	25.22	24.57	24.03	Pass
48	5240	25.18	24.74	24.22	Pass

**802.11n (HT20)**

Channel	Channel Frequency (MHz)	26dBc Bandwidth (MHz)			Pass / Fail
		Chain 0	Chain 1	Chain 2	
36	5180	25.51	25.88	25.19	Pass
40	5200	26.18	25.90	25.08	Pass
48	5240	25.78	25.55	25.29	Pass

**802.11n (HT40)**

Channel	Channel Frequency (MHz)	26dBc Bandwidth (MHz)			Pass / Fail
		Chain 0	Chain 1	Chain 2	
38	5190	54.88	52.41	51.45	Pass
46	5230	54.10	52.23	52.84	Pass



**Spectrum Plot of Worst Value**

802.11a

802.11n (HT20)

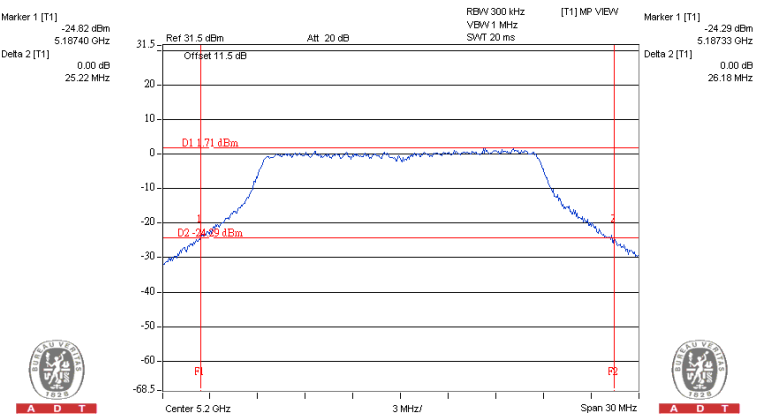
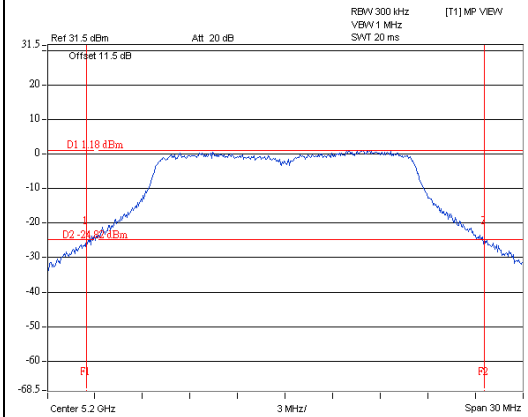

802.11n (HT40)

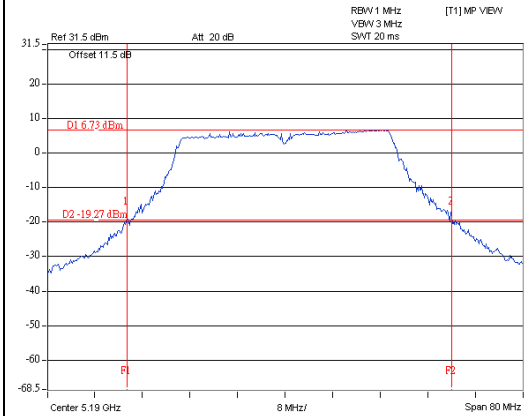

## Occupied Bandwidth:

## 802.11a

Channel	Channel Frequency (MHz)	Occupied Bandwidth (MHz)		
		Chain 0	Chain 1	Chain 2
36	5180	17.58	17.22	17.10
40	5200	17.52	17.22	17.10
48	5240	17.64	17.22	17.10

## 802.11n (HT20)

Channel	Channel Frequency (MHz)	Occupied Bandwidth (MHz)		
		Chain 0	Chain 1	Chain 2
36	5180	18.54	18.42	18.36
40	5200	18.60	18.42	18.36
48	5240	18.66	18.36	18.24

## 802.11n (HT40)

Channel	Channel Frequency (MHz)	Occupied Bandwidth (MHz)		
		Chain 0	Chain 1	Chain 2
38	5190	39.20	38.88	38.40
46	5230	39.20	38.56	38.40

### Spectrum Plot of Worst Value

802.11a

802.11n (HT20)

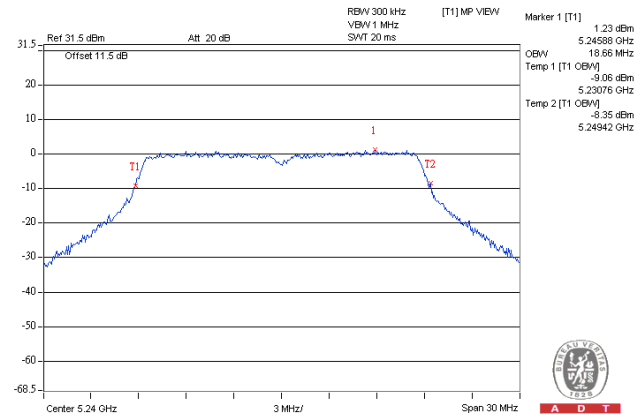
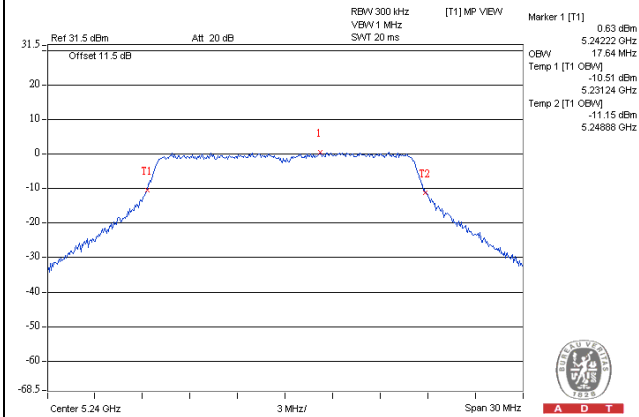

802.11n (HT40)

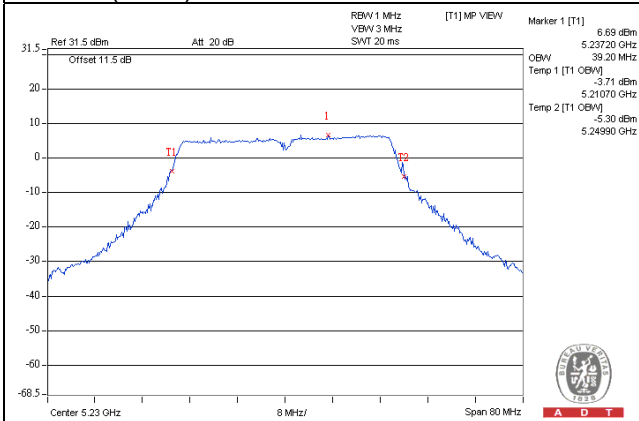

#### 4.4 Peak Power Spectral Density Measurement

##### 4.4.1 Limits of Peak Power Spectral Density Measurement

Operation Band	EUT Category		LIMIT
U-NII-1		Outdoor Access Point	17dBm/ MHz
		Fixed point-to-point Access Point	
	√	Indoor Access Point	11dBm/ MHz
		Mobile and Portable client device	
U-NII-2A	---		11dBm/ MHz
U-NII-2C	---		11dBm/ MHz
U-NII-3	---		30dBm/ 500kHz

##### 4.4.2 Test Setup

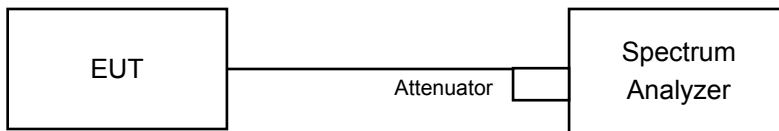

##### 4.4.3 Test Instruments

Refer to section 4.1.2 to get information of above instrument.

##### 4.4.4 Test Procedures

###### 80211a / 802.11an 20MHz

Using method SA-2

- Set span to encompass the entire emission bandwidth (EBW) of the signal.
- Set RBW = 1 MHz, Set VBW ≥ 3 MHz, Detector = RMS
- Sweep time = auto, trigger set to “free run”.
- Trace average at least 100 traces in power averaging mode.
- Record the max value

###### 802.11an 40MHz

Using method SA-2 alternative

- Set span to encompass the entire emission bandwidth (EBW) of the signal.
- Set RBW = 1 MHz, Set VBW ≥ 3 MHz, Detector = RMS
- Sweep time = SWT 4s second.
- Perform a single sweep.
- Record the max value and add 10 log (1/duty cycle)

#### 4.4.5 Deviation from Test Standard

No deviation.

#### 4.4.6 EUT Operating Conditions

Same as Item 4.3.6.

#### 4.4.7 Test Results

For U-NII-1 Band

802.11a

Chan.	Freq. (MHz)	PSD (dBm)			Total PSD (dBm)	Max. Limit (dBm)	Pass / Fail
		Chain 0	Chain 1	Chain 2			
36	5180	-2.09	-3.05	-2.13	2.232	15.70	Pass
40	5200	-2.20	-2.63	-1.68	2.458	15.70	Pass
48	5240	-2.50	-2.69	-1.82	2.227	15.70	Pass

Note:

- Method 1 of power density measurement of KDB 662911 is using for calculating total power density. Total power density is summing entire spectra across corresponding frequency bins on the various outputs by computer.
- Directional gain =  $2.5\text{dBi} + 10\log(3) = 7.3\text{dBi} > 6\text{dBi}$ , so the power density limit shall be reduced to  $17-(7.3-6) = 15.70\text{dBm}$ .
- Refer to section 3.3 for duty cycle spectrum plot.

802.11n (HT20)

Chan.	Freq. (MHz)	PSD (dBm)			Total PSD (dBm)	Max. Limit (dBm)	Pass / Fail
		Chain 0	Chain 1	Chain 2			
36	5180	-1.96	-3.31	-1.91	2.284	15.70	Pass
40	5200	-2.05	-3.37	-1.98	2.285	15.70	Pass
48	5240	-2.17	-3.14	-1.72	2.209	15.70	Pass

Note:

- Method 1 of power density measurement of KDB 662911 is using for calculating total power density. Total power density is summing entire spectra across corresponding frequency bins on the various outputs by computer.
- Directional gain =  $2.5\text{dBi} + 10\log(3) = 7.3\text{dBi} > 6\text{dBi}$ , so the power density limit shall be reduced to  $17-(7.3-6) = 15.70\text{dBm}$ .
- Refer to section 3.3 for duty cycle spectrum plot.

802.11n (HT40)

Chan.	Freq. (MHz)	PSD (dBm)			Total PSD w/o duty factor (dBm)	Duty factor	Total PSD with duty factor (dBm)	Max. Limit (dBm)	Pass / Fail
		Chain 0	Chain 1	Chain 2					
38	5190	-2.51	-4.19	-3.08	1.530	0.16	1.690	15.70	Pass
46	5230	-2.25	-3.52	-2.06	2.091	0.16	2.251	15.70	Pass

Note:

- Method 1 of power density measurement of KDB 662911 is using for calculating total power density. Total power density is summing entire spectra across corresponding frequency bins on the various outputs by computer.
- Directional gain =  $2.5\text{dBi} + 10\log(3) = 7.3\text{dBi} > 6\text{dBi}$ , so the power density limit shall be reduced to  $17-(7.3-6) = 15.70\text{dBm}$ .
- Refer to section 3.3 for duty cycle spectrum plot.

### Spectrum Plot of Worst Value

802.11a / Chain 2 / CH 40

802.11n (HT20) / Chain 2 / CH 48

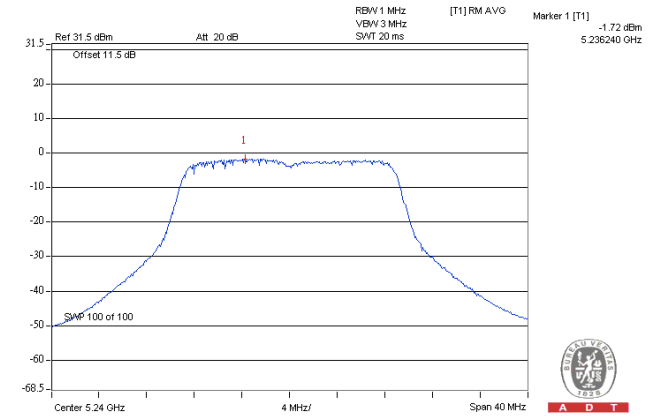
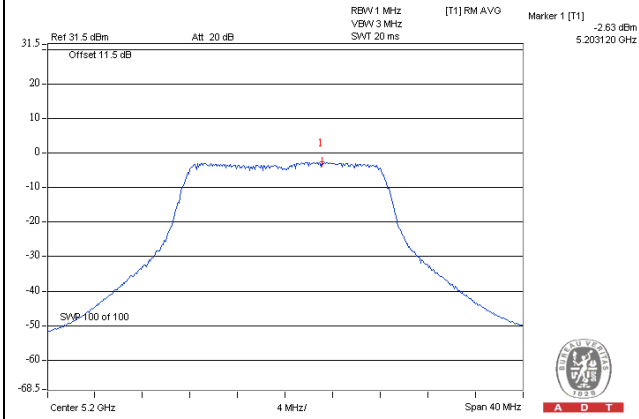

802.11n (HT40) / Chain 2 / CH 46

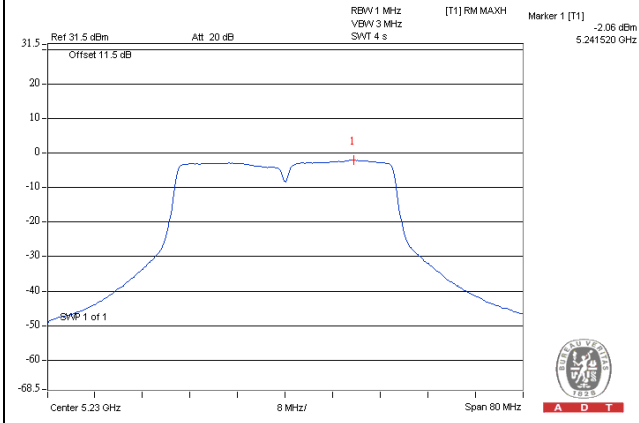

## 4.5 Frequency Stability

### 4.5.1 Limits of Frequency Stability Measurement

The frequency of the carrier signal shall be maintained within band of operation

### 4.5.2 Test Setup

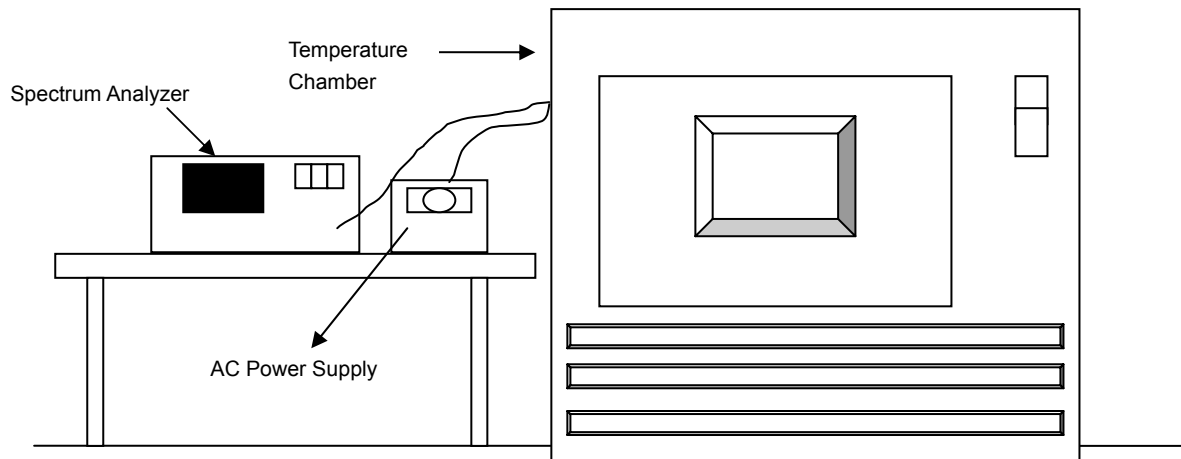

### 4.5.3 Test Instruments

Refer to section 4.1.2 to get information of above instrument.

### 4.5.4 Test Procedure

- a. The EUT was placed inside the environmental test chamber and powered by nominal AC voltage.
- b. Turn the EUT on and couple its output to a spectrum analyzer.
- c. Turn the EUT off and set the chamber to the highest temperature specified.
- d. Allow sufficient time (approximately 30 min) for the temperature of the chamber to stabilize, turn the EUT on and measure the operating frequency after 2, 5, and 10 minutes.
- e. Repeat step 2 and 3 with the temperature chamber set to the lowest temperature.
- f. The test chamber was allowed to stabilize at +20 degree C for a minimum of 30 minutes. The supply voltage was then adjusted on the EUT from 85% to 115% and the frequency record.

### 4.5.5 Deviation from Test Standard

No deviation.

### 4.5.6 EUT Operating Condition

Set the EUT transmit at un-modulation mode to test frequency stability.



#### 4.5.7 Test Results

Frequency Stability Versus Temp.									
Operating Frequency: 5200MHz									
Temp. ( )	Power Supply (Vdc)	0 Minute		2 Minute		5 Minute		10 Minute	
		Measured Frequency (MHz)	Frequency Drift (ppm)	Measured Frequency (MHz)	Frequency Drift (ppm)	Measured Frequency (MHz)	Frequency Drift (ppm)	Measured Frequency (MHz)	Frequency Drift (ppm)
50	120	5199.988131	-2.282	5199.988789	-2.156	5199.988680	-2.177	5199.988296	-2.251
40	120	5199.988802	-2.153	5199.988736	-2.166	5199.988781	-2.157	5199.989152	-2.086
30	120	5199.990534	-1.820	5199.989991	-1.925	5199.989996	-1.924	5199.990587	-1.810
20	120	5199.991602	-1.615	5199.991433	-1.647	5199.991801	-1.577	5199.991623	-1.611
10	120	5199.992403	-1.461	5199.992671	-1.409	5199.992425	-1.457	5199.992750	-1.394
0	120	5199.991065	-1.718	5199.990852	-1.759	5199.990916	-1.747	5199.991143	-1.703
-10	120	5199.989544	-2.011	5199.989863	-1.949	5199.989270	-2.063	5199.989251	-2.067
-20	120	5199.989111	-2.094	5199.989200	-2.077	5199.989577	-2.004	5199.989148	-2.087
-30	120	5199.988153	-2.278	5199.987790	-2.348	5199.988322	-2.246	5199.987955	-2.316

Frequency Stability Versus Voltage									
Operating Frequency: 5200MHz									
Temp. ( )	Power Supply (Vdc)	0 Minute		2 Minute		5 Minute		10 Minute	
		Measured Frequency (MHz)	Frequency Drift (ppm)	Measured Frequency (MHz)	Frequency Drift (ppm)	Measured Frequency (MHz)	Frequency Drift (ppm)	Measured Frequency (MHz)	Frequency Drift (ppm)
20	102	5199.992081	-1.523	5199.991791	-1.579	5199.991608	-1.614	5199.991995	-1.539
	120	5199.992403	-1.461	5199.992671	-1.409	5199.992425	-1.457	5199.992750	-1.394
	138	5199.990968	-1.737	5199.991662	-1.603	5199.991094	-1.713	5199.991485	-1.637

## **5 Pictures of Test Arrangements**

Please refer to the attached file (Test Setup Photo).

## Appendix – Information on the Testing Laboratories

We, Bureau Veritas Consumer Products Services (H.K.) Ltd., Taoyuan Branch, were founded in 1988 to provide our best service in EMC, Radio, Telecom and Safety consultation. Our laboratories are accredited and approved according to ISO/IEC 17025.

If you have any comments, please feel free to contact us at the following:

**Linko EMC/RF Lab**

Tel: 886-2-26052180

Fax: 886-2-26051924

**Hsin Chu EMC/RF/Telecom Lab**

Tel: 886-3-6668565

Fax: 886-3-6668323

**Hwa Ya EMC/RF/Safety Lab**

Tel: 886-3-3183232

Fax: 886-3-3270892

**Email:** [service.adt@tw.bureauveritas.com](mailto:service.adt@tw.bureauveritas.com)

**Web Site:** [www.bureauveritas-adt.com](http://www.bureauveritas-adt.com)

The address and road map of all our labs can be found in our web site also.

--- END ---