

FCC RADIO TEST REPORT

According to

47 CFR FCC Part 15 Subpart C § 15.247

Equipment : N600 Wireless Dual Band Gigabit
ADSL MODEM ROUTER

Brand Name : Netgear

Model No. : DGND3700v2

Filing Type : New Application

Applicant : Netgear Inc.

Manufacturer : 350 East Plumeria Drive San Jose,
CA 95134 U.S.A.

FCC ID : PY311400180

Received Date : Mar. 16, 2012

Final Test Date : Apr. 08, 2012

Statement

Test result included is only for the 802.11b/g/n part of the product.

The test result in this report refers exclusively to the presented test model / sample.

Without written approval of SPORTON International Inc., the test report shall not be reproduced except in full.

The measurements and test results shown in this test report were made in accordance with the procedures and found in compliance with the limit given in **ANSI C63.4-2003** and **47 CFR FCC Part 15 Subpart C**.

The test equipment used to perform the test is calibrated and traceable to NML/ROC.



SPORTON International Inc.

No. 52, Hwa Ya 1st Rd., Hwa Ya Technology Park, Kwei-Shan Hsiang, Tao Yuan Hsien, Taiwan, R.O.C.

Table of Contents

1 SUMMARY OF THE TEST RESULT 2

2 GENERAL INFORMATION..... 3

2.1 Product Details.....3

2.2 Accessories.....4

2.3 Table for Filed Antenna.....4

2.4 Table for Carrier Frequencies.....5

2.5 Table for Test Modes.....5

2.6 Table for Testing Locations.....6

2.7 Table for Supporting Units.....6

2.8 Table for Parameters of Test Software Setting.....6

2.9 EUT Operation during Test.....7

2.10 Test Configuration.....7

3 TEST RESULT 9

3.1 AC Power Line Conducted Emissions Measurement9

3.2 Maximum Peak Output Power Measurement13

3.3 Power Spectral Density Measurement.....16

3.4 6dB Spectrum Bandwidth Measurement35

3.5 Radiated Emissions Measurement70

3.6 Band Edge and Fundamental Emissions Measurement.....120

3.7 Antenna Requirements135

4 LIST OF MEASURING EQUIPMENTS 136

5 TEST LOCATION..... 138

6 TAF CERTIFICATE OF ACCREDITATION..... 139

APPENDIX A. TEST PHOTOS A6

APPENDIX B. PHOTOGRAPHS OF EUT B20

CERTIFICATE OF COMPLIANCE

According to

47 CFR FCC Part 15 Subpart C § 15.247

Equipment : N600 Wireless Dual Band Gigabit
ADSL MODEM ROUTER

Brand Name : Netgear

Model No. : DGND3700v2

Applicant : Netgear Inc.

350 East Plumeria Drive San Jose,
CA 95134 U.S.A.

Sporton International as requested by the applicant to evaluate the EMC performance of the product sample received on Mar. 16, 2012 would like to declare that the tested sample has been evaluated and found to be in compliance with the tested rule parts. The data recorded as well as the test configuration specified is true and accurate for showing the sample's EMC nature.

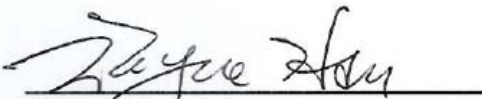

Wayne Hsu / Assistant Manager

SPORTON International Inc.

No. 52, Hwa Ya 1st Rd., Hwa Ya Technology Park, Kwei-Shan Hsiang, Tao Yuan Hsien, Taiwan, R.O.C.

1 SUMMARY OF THE TEST RESULT

Applied Standard: 47 CFR FCC Part 15 Subpart C				
Part	Rule Section	Description of Test	Result	Under Limit
3.1	15.207	AC Power Line Conducted Emissions	Complies	13.05 dB
3.2	15.247(b)(3)	Maximum Peak Output Power	Complies	3.50 dB
3.3	15.247(e)	Power Spectral Density	Complies	14.10 dB
3.4	15.247(a)(2)	6dB Spectrum Bandwidth Measurement	Complies	-
3.5	15.247(d)	Radiated Emissions	Complies	0.73 dB
3.6	15.247(d)	Band Edge Emissions	Complies	1.00 dB
3.7	15.203	Antenna Requirements	Complies	-

Test Items	Uncertainty	Remark
AC Power Line Conducted Emissions	±2.3dB	Confidence levels of 95%
Maximum Peak Output Power	±0.8dB	Confidence levels of 95%
Power Spectral Density	±0.5dB	Confidence levels of 95%
6dB Spectrum Bandwidth Measurement	±8.5×10 ⁻⁸	Confidence levels of 95%
Radiated Emissions (9kHz~30MHz)	±0.8dB	Confidence levels of 95%
Radiated Emissions (30MHz~1000MHz)	±1.9dB	Confidence levels of 95%
Radiated / Band Edge Emissions (1GHz~18GHz)	±1.9dB	Confidence levels of 95%
Radiated Emissions (18GHz~40GHz)	±1.9dB	Confidence levels of 95%
Temperature	±0.7°C	Confidence levels of 95%
Humidity	±3.2%	Confidence levels of 95%
DC / AC Power Source	±1.4%	Confidence levels of 95%

2 GENERAL INFORMATION

2.1 Product Details

Only the radio detail of IEEE 802.11b/g/n is shown in this report. For more detailed features description, please refer to the manufacturer's specifications or user's manual.

Items	Description
Power Type	From 12V adapter
Data Modulation Data Rate (Mbps)	DSSS for IEEE 802.11b (DBPSK / DQPSK / CCK) (1/2/ 5.5/11) OFDM for IEEE 802.11g (BPSK / QPSK / 16QAM / 64QAM) (6/9/12/18/24/36/48/54) See the below table for IEEE 802.11n
Frequency Range	2400 ~ 2483.5MHz
Channel Number	11b/g/n (20MHz): 11 ; 11/n (40MHz): 7
Channel Band Width (99%)	802.11b/g : 11b: 10.32 MHz ; 11g: 16.36 MHz 802.11n : MCS 0 (20MHz) : 17.48 MHz ; MCS 0 (40MHz) : 36.24 MHz MCS 8 (20MHz) : 17.48 MHz ; MCS 8 (40MHz) : 36.24 MHz
Conducted Output Power	802.11b/g : 11b: 19.46 dBm ; 11g: 23.42 dBm 802.11n : MCS 0 (20MHz) : 23.46 dBm ; MCS 0 (40MHz) : 23.48 dBm MCS 8 (20MHz) : 26.50 dBm ; MCS 8 (40MHz) : 25.41 dBm

IEEE 802.11n Modulation Scheme

MCS	Spatial	Modulation	Coding Rate	Data rate(Mbps)	
Index	Streams	Type	Type	20 MHz channel 800nsGI	40 MHz channel 800nsGI
0	1	BPSK	1/2	6.5	13.5
1	1	QPSK	1/2	13	27
2	1	QPSK	3/4	19.5	40.5
3	1	16-QAM	1/2	26	54
4	1	16-QAM	3/4	39	81
5	1	64-QAM	2/3	52	108
6	1	64-QAM	3/4	58.5	121.5
7	1	64-QAM	5/6	65	135
8	2	BPSK	1/2	13	27
9	2	QPSK	1/2	26	54
10	2	QPSK	3/4	39	81
11	2	16-QAM	1/2	52	108
12	2	16-QAM	3/4	78	162
13	2	64-QAM	2/3	104	216
14	2	64-QAM	3/4	117	243
15	2	64-QAM	5/6	130	270

Symbol	Explanation
NSS	Number of spatial streams
R	Code rate
NBPSC	Number of coded bits per single carrier
NCBPS	Number of coded bits per symbol
NDBPS	Number of data bits per symbol
GI	guard interval

2.2 Accessories

Accessories Information				
AC Adapter 1	Brand Name	PIE	Model Name	P030WF120B 11200-6LF
	Power Rating	I/P: 100-240V~50/60Hz 1.0A; O/P: 12.0V 2.5A		

Note: Regarding to more detail and other information, please refer to user manual.

2.3 Table for Filed Antenna

Antenna Category (Ant. Cat.)	
<input checked="" type="checkbox"/>	Integral antenna (antenna permanently attached)
<input checked="" type="checkbox"/>	Temporary RF connector provided ; <input type="checkbox"/> No temporary RF connector provided

Transmitter Outputs & Receiver Inputs Information				
Modulation	Transmitter Outputs	Receiver Inputs	Transmitter Output Signals	Co-location
802.11b/g	1	1	-	Yes
802.11n HT20 / HT40	1	1	-	Yes
802.11n HT20 / HT40	2	2	-	Yes

Note : Co-location, Co-location is generally defined as simultaneously transmitting (co-transmitting) antennas within 20 cm of each other.

Antenna General Information									
Antenna Port (Total 2 Port)				1(TX/RX), 2(TX/RX)					
Maximum RF Output Power Level (PL)				1					
Transmit Chains Power Distribution				<input checked="" type="checkbox"/> symmetrical distribution <input type="checkbox"/> asymmetrical distribution					
Ant. No.	PL	Ant. Port [Ant No. X connect to Ant. Port Y]	Ant. Cat.	Ant. Type	Brand	Model	G _{ANT} (dBi)	DG (dBi) [correlated] N _{TX} = 1	DG (dBi) [uncorrelated] N _{TX} = 2
1	1	1	Integral	PCB	--	--	2.99	N/A	3
2	1	2	Integral	PCB	--	--	3.07		
<input checked="" type="checkbox"/>		The equipment is normally installed and point-to-point or point-to-multipoint systems: Ant. No. 1, 2							
<p>Note 1: For all transmitter outputs with equal antenna gains, directional gain is to be computed as follows: Any transmit signals are correlated, Directional Gain (DG) = G_{ANT} + 10 log(N) dBi All transmit signals are completely uncorrelated, Directional Gain (DG)= G_{ANT}</p> <p>Note 2: For all transmitter outputs with unequal antenna gains, directional gain is to be computed as follows: Any transmit signals are correlated, Directional Gain (DG) = $10 \log[(10^{G_{1/20}} + 10^{G_{2/20}} + \dots + 10^{G_{N/20}})^2 / N]$ dBi All transmit signals are completely uncorrelated, Directional Gain (DG) = $10 \log[(10^{G_{1/10}} + 10^{G_{2/10}} + \dots + 10^{G_{N/10}/N}]$ dBi</p>									

2.4 Table for Carrier Frequencies

There are two bandwidth systems for IEEE 802.11b/g/n.
 For IEEE 802.11 b/g/n (20MHz) bandwidth systems use channel 1 ~ 11.
 For IEEE 802.11 n (40MHz) bandwidth systems use channel 3 ~ 9.

Frequency Band	Channel No.	Frequency	Channel No.	Frequency
2400~2483.5MHz	1	2412 MHz	7	2442 MHz
	2	2417 MHz	8	2447 MHz
	3	2422 MHz	9	2452 MHz
	4	2427 MHz	10	2457 MHz
	5	2432 MHz	11	2462 MHz
	6	2437 MHz	-	-

2.5 Table for Test Modes

Preliminary tests were performed in different data rate to find the worst radiated emission. The data rate shown in the table below is the worst-case rate with respect to the specific test item. Investigation has been done on the entire possible configuration for searching the worst cases. The following table is a list of the test modes shown in this test report.

Test Items	Mode	Data Rate	Channel
AC Power Line Conducted Emissions	Transmitting mode	-	-
Maximum Peak Output Power Power Spectral Density	11b/CCK	1 Mbps	1/6/11
	11g/BPSK	6 Mbps	1/6/11
	MCS 0 (20MHz)	6.5 Mbps	1/6/11
	MCS 0 (40MHz)	13.5 Mbps	3/6/9
	MCS 8 (20MHz)	13 Mbps	1/6/11
6dB Spectrum Bandwidth Measurement	MCS 8 (40MHz)	27 Mbps	3/6/9
	11b/CCK	1 Mbps	1/6/11
	11g/BPSK	6 Mbps	1/6/11
	MCS 0 (20MHz)	6.5 Mbps	1/6/11
	MCS 0 (40MHz)	13.5 Mbps	3/6/9
Radiated Emissions Below 1GHz	MCS 8 (20MHz)	13 Mbps	1/6/11
	MCS 8 (40MHz)	27 Mbps	3/6/9
	11g/BPSK	6 Mbps	6
	MCS 0 (20MHz)	6.5 Mbps	6
	MCS 0 (40MHz)	13.5 Mbps	6
Radiated Emissions Above 1GHz Fundamental Emissions	MCS 8 (20MHz)	13 Mbps	6
	MCS 8 (40MHz)	27 Mbps	6
	11b/CCK	1 Mbps	1/6/11
	11g/BPSK	6 Mbps	1/6/11
	MCS 0 (20MHz)	6.5 Mbps	1/6/11
	MCS 0 (40MHz)	13.5 Mbps	3/6/9
Band Edge Emissions	MCS 8 (20MHz)	13 Mbps	1/6/11
	MCS 8 (40MHz)	27 Mbps	3/6/9
	11b/CCK	1 Mbps	1/11
	11g/BPSK	6 Mbps	1/11
	MCS 0 (20MHz)	6.5 Mbps	1/11
	MCS 0 (40MHz)	13.5 Mbps	3/9

2.6 Table for Testing Locations

Test Site No.	Site Category	Location
CO04-HY	Conduction	Hwa Ya
TH01-HY	OVEN Room	Hwa Ya
03CH02-HY	SAC	Hwa Ya

Semi Anechoic Chamber (SAC).

2.7 Table for Supporting Units

Support Unit	Brand	Model	FCC ID
Notebook	DELL	E5520	DoC

2.8 Table for Parameters of Test Software Setting

During testing, Channel & Power Controlling Software provided by the customer was used to control the operating channel as well as the output power level. The RF output power selection is for the setting of RF output power expected by the customer and is going to be fixed on the firmware of the final end product.

For Single Chain:

Power Parameters of IEEE 802.11b/g Port 1

Test Software Version	DOS		
Frequency	2412 MHz	2437 MHz	2462 MHz
IEEE 802.11b	15	15	15
IEEE 802.11g	14	16	14

Power Parameters of IEEE 802.11n Pot 1

Test Software Version	DOS		
Frequency	2412 MHz	2437 MHz	2462 MHz
IEEE 802.11n (20MHz)	13	16	13
Frequency	2422 MHz	2437 MHz	2452 MHz
IEEE 802.11n (40MHz)	10	15	12

For Two Chains:

Power Parameters of IEEE 802.11n Port 1+ Port 2

Test Software Version	DOS		
Frequency	2412 MHz	2437 MHz	2462 MHz
IEEE 802.11n (20MHz)	10 ; 10	15 ; 15	12 ; 12
Frequency	2422 MHz	2437 MHz	2452 MHz
IEEE 802.11n (40MHz)	10 ; 10	13 ; 13	10 ; 10

2.9 EUT Operation during Test

An executive program, "EMCTEST.EXE" under Win XP, which generates a complete line of continuously repeating "H" pattern was used as the test software.

The program was executed as follows:

- a. Turn on the power of all equipment.
- b. The NB reads the test program from the hard disk drive and runs it.
- c. The NB sends "H" messages to the panel and displays "H" patterns on the screen.

At the same time, the following programs were executed:

The Notebook executed "DOS command" to EUT keep transmitting signals at fixed frequency via RJ45.

2.10 Test Configuration

For conducted emissions

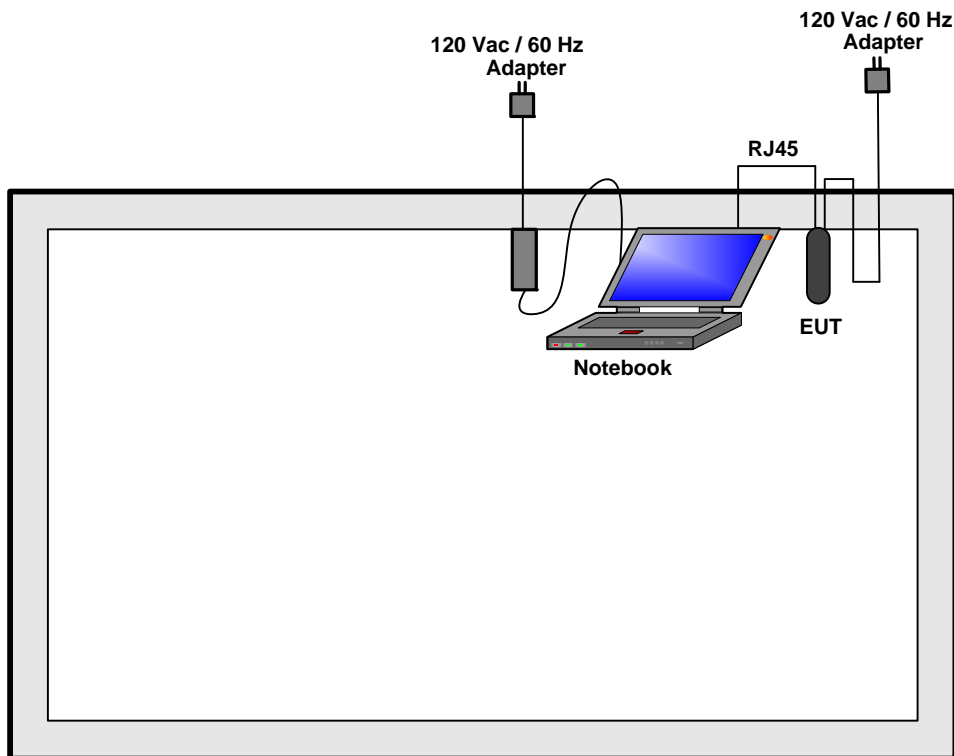

For radiated emissions 9kHz~1GHz

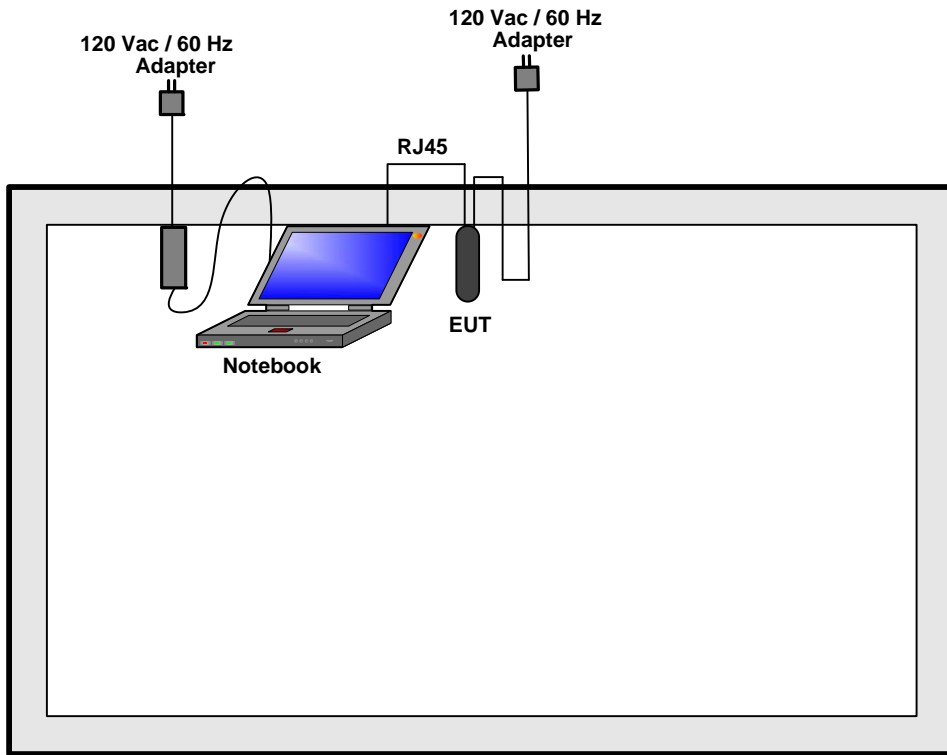

For radiated emissions above 1GHz

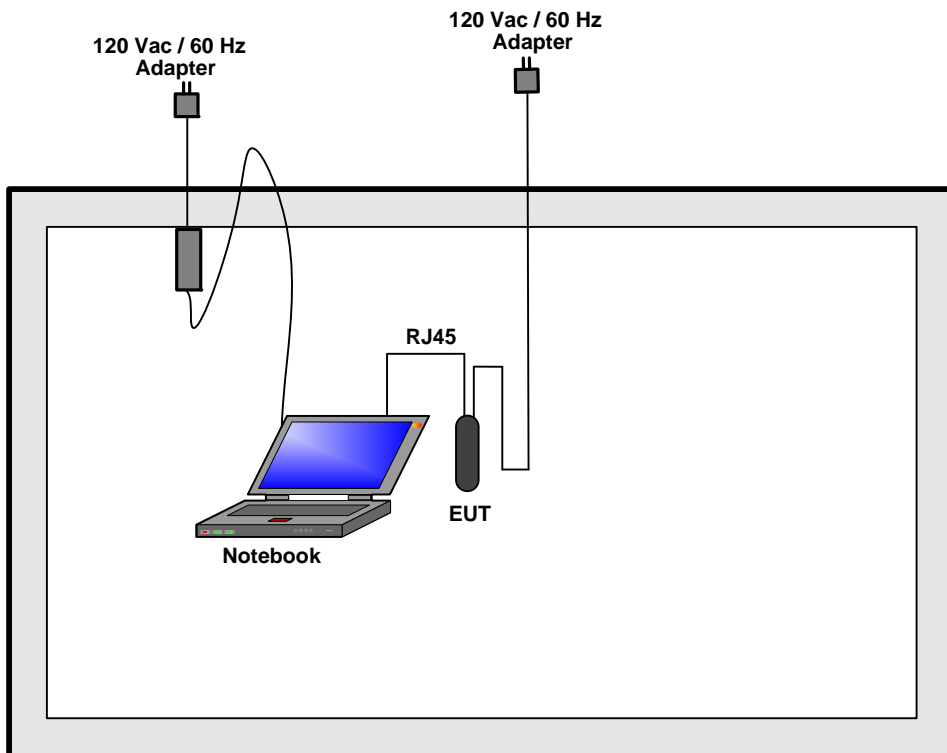

3 TEST RESULT

3.1 AC Power Line Conducted Emissions Measurement

3.1.1 Limit

For this product which is designed to be connected to the AC power line, the radio frequency voltage that is conducted back onto the AC power line on any frequency or frequencies within the band 150 kHz to 30 MHz shall not exceed below limits table.

Class B

Frequency (MHz)	QP Limit (dBuV)	AV Limit (dBuV)
0.15~0.5	66~56	56~46
0.5~5	56	46
5~30	60	50

3.1.2 Measuring Instruments and Setting

Please refer to section 4 of equipments list in this report. The following table is the setting of the receiver.

Receiver Parameters	Setting
Attenuation	10 dB
Start Frequency	0.15 MHz
Stop Frequency	30 MHz
IF Bandwidth	9 kHz

3.1.3 Test Procedures

1. The EUT warm up about 15 minutes then start test.
2. Configure the EUT according to ANSI C63.4. The EUT or host of EUT has to be placed 0.4 meter far from the conducting wall of the shielding room and at least 80 centimeters from any other grounded conducting surface.
3. Connect EUT or host of EUT to the power mains through a line impedance stabilization network (LISN).
4. All the support units are connected to the other LISNs. The LISN should provide 50uH/50ohms coupling impedance.
5. The frequency range from 150 kHz to 30 MHz was searched.
6. Set the test-receiver system to Peak Detect Function and Specified Bandwidth with Maximum Hold Mode.
7. The measurement has to be done between each power line and ground at the power terminal.

3.1.4 Test Setup Layout

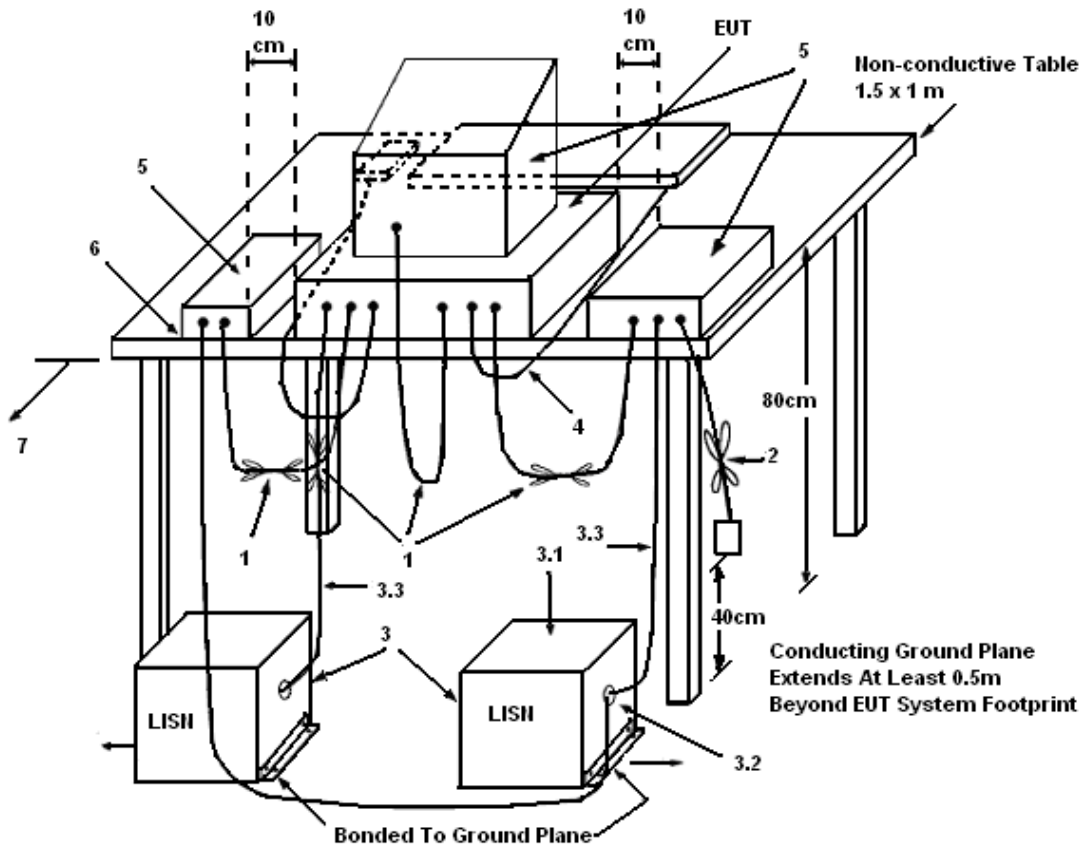

LEGEND:

- (1) Interconnecting cables that hang closer than 40 cm to the ground plane shall be folded back and forth in the center forming a bundle 30 to 40 cm long.
- (2) I/O cables that are not connected to a peripheral shall be bundled in the center. The end of the cable may be terminated, if required, using the correct terminating impedance. The overall length shall not exceed 1 m.
- (3) EUT connected to one LISN. Unused LISN measuring port connectors shall be terminated in 50 Ω. LISN can be placed on top of, or immediately beneath, reference ground plane.
- (3.1) All other equipment powered from additional LISN(s).
- (3.2) Multiple outlet strip can be used for multiple power cords of non-EUT equipment.
- (3.3) LISN at least 80 cm from nearest part of EUT chassis.
- (4) Cables of hand-operated devices, such as keyboards, mice, etc., shall be placed as for normal use.
- (5) Non-EUT components of EUT system being tested.
- (6) Rear of EUT, including peripherals, shall all be aligned and flush with rear of tabletop.
- (7) Rear of tabletop shall be 40 cm removed from a vertical conducting plane that is bonded to the ground plane.

3.1.5 Test Deviation

There is no deviation with the original standard.

3.1.6 EUT Operation during Test

The EUT was placed on the test table and programmed in transmitting function.

3.1.7 Results of AC Power Line Conducted Emissions Measurement

Final Test Date	Apr. 03, 2012	Test Site No.	CO04-HY
Temperature	23°C	Humidity	46%
Test Engineer	Alan	Configuration	Transmitting mode

Line

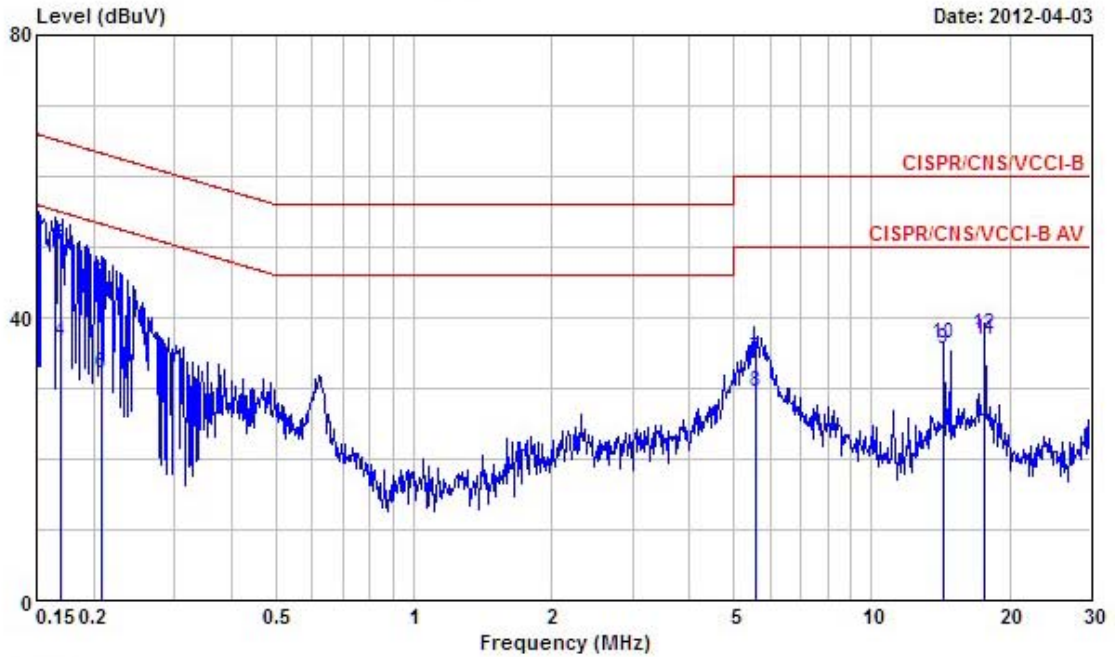

	Freq	Level	Over Limit	Limit Line	Read Level	LISN Factor	Cable Loss	Remark
	MHz	dBuV	dB	dBuV	dBuV	dB	dB	
1	0.150000	52.84	-13.16	66.00	52.46	0.30	0.08	QP
2	0.150000	37.73	-18.27	56.00	37.35	0.30	0.08	Average
3	0.169840	50.21	-14.76	64.97	49.86	0.30	0.05	QP
4	0.169840	36.48	-18.49	54.97	36.13	0.30	0.05	Average
5	0.208332	44.72	-18.55	63.27	44.41	0.30	0.01	QP
6	0.208332	32.11	-21.16	53.27	31.80	0.30	0.01	Average
7	5.590	34.20	-25.80	60.00	33.68	0.38	0.14	QP
8	5.590	29.47	-20.53	50.00	28.95	0.38	0.14	Average
9	14.380	35.50	-14.50	50.00	34.52	0.52	0.46	Average
10	14.380	36.24	-23.76	60.00	35.26	0.52	0.46	QP
11	17.627	36.95	-13.05	50.00	36.05	0.56	0.34	Average
12	17.627	37.73	-22.27	60.00	36.83	0.56	0.34	QP

Neutral

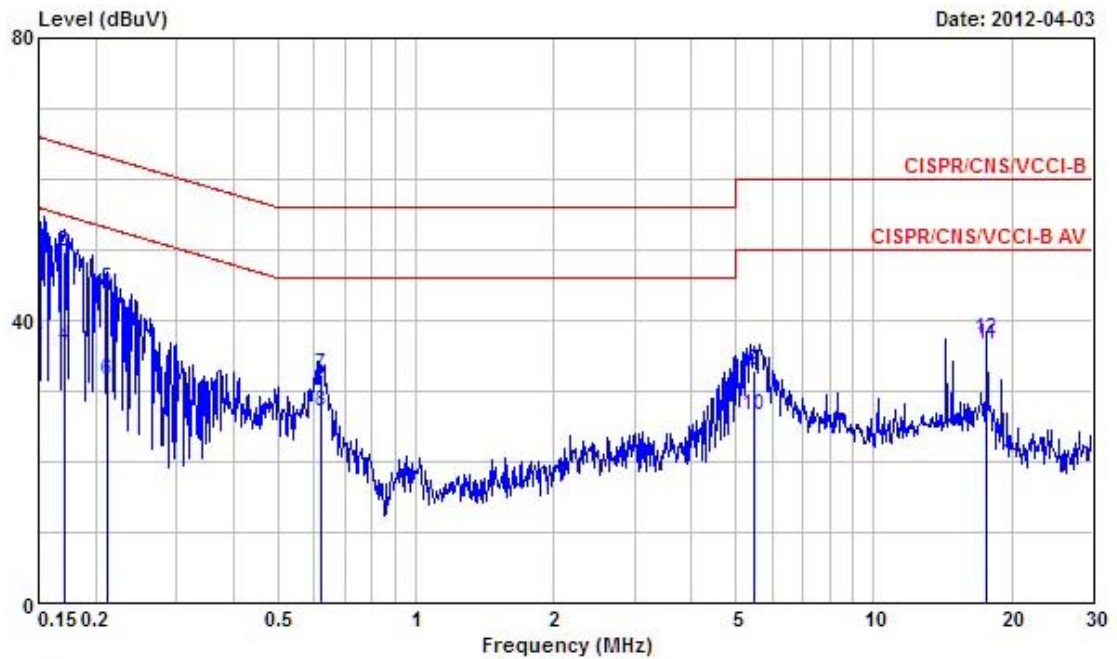

	Freq	Level	Over	Limit	Read	LISN	Cable	
	MHz	dBuV	Limit	Line	Level	Factor	Loss	Remark
			dB	dBuV	dBuV	dB	dB	
1	0.1500000	52.14	-13.86	66.00	51.79	0.27	0.08	QP
2	0.1500000	36.60	-19.40	56.00	36.25	0.27	0.08	Average
3	0.1711630	49.71	-15.19	64.90	49.41	0.26	0.04	QP
4	0.1711630	36.44	-18.46	54.90	36.14	0.26	0.04	Average
5	0.2127940	44.43	-18.67	63.10	44.16	0.25	0.02	QP
6	0.2127940	31.59	-21.51	53.10	31.32	0.25	0.02	Average
7	0.6207510	32.33	-23.67	56.00	31.99	0.24	0.10	QP
8	0.6207510	27.10	-18.90	46.00	26.76	0.24	0.10	Average
9	5.485	32.98	-27.02	60.00	32.53	0.32	0.13	QP
10	5.485	26.67	-23.33	50.00	26.22	0.32	0.13	Average
11	17.622	36.57	-13.43	50.00	35.77	0.46	0.34	Average
12	17.622	37.30	-22.70	60.00	36.50	0.46	0.34	QP

Note:
Level = Read Level + LISN Factor + Cable Loss.

3.2 Maximum Peak Output Power Measurement

3.2.1 Limit

For systems using digital modulation in the 2400-2483.5MHz, the limit for peak output power is 30dBm. The limited has to be reduced by the amount in dB that the gain of the antenna exceed 6dBi. In case of point-to-multipoint antenna reduction operation, the limit has to be reduced by 1dB for every dB that the directional gain of the antenna exceeds 6dBi.

3.2.2 Measuring Instruments and Setting

Please refer to section 4 of equipments list in this report. The following table is the setting of the power meter.

Power Meter Parameter	Setting
Filter No.	Auto
Measurement time	0.135 s ~ 26 s
Used Peak Sensor	MA2411B

3.2.3 Test Procedures

1. The transmitter output (antenna port) was connected to the power meter.
2. Turn on the EUT and power meter and then record the peak power value.
3. Repeat above procedures on all channels needed to be tested.
4. When measuring maximum conducted output power within multiple antenna systems, add every result of the values by mathematic formula. (Only for IEEE 802.11n test)

3.2.4 Test Setup Layout

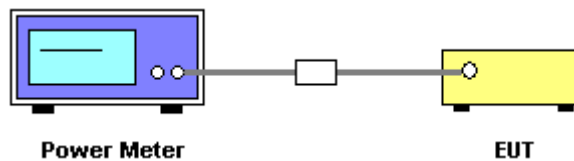

3.2.5 Test Deviation

There is no deviation with the original standard.

3.2.6 EUT Operation during Test

The EUT was programmed to be in continuously transmitting mode.

3.2.7 Test Result of Maximum Peak Output Power

Final Test Date	Apr. 08, 2012	Test Site No.	TH01-HY
Temperature	23°C	Humidity	33%
Test Engineer	Shiming	Configurations	802.11b/g/n

For Single Chain:

Configuration IEEE 802.11b Port 1

Channel	Frequency	Conducted Power (dBm)	Max. Limit (dBm)	Result
1	2412 MHz	19.46	30.00	Complies
6	2437 MHz	19.34	30.00	Complies
11	2462 MHz	19.18	30.00	Complies

Configuration IEEE 802.11g Port 1

Channel	Frequency	Conducted Power (dBm)	Max. Limit (dBm)	Result
1	2412 MHz	22.21	30.00	Complies
6	2437 MHz	23.42	30.00	Complies
11	2462 MHz	22.12	30.00	Complies

Configuration of IEEE 802.11n (20MHz) Port 1

Channel	Frequency	Conducted Power (dBm)	Max. Limit (dBm)	Result
1	2412 MHz	21.41	30.00	Complies
6	2437 MHz	23.46	30.00	Complies
11	2462 MHz	20.95	30.00	Complies

Configuration of IEEE 802.11n (40MHz) Port 1

Channel	Frequency	Conducted Power (dBm)	Max. Limit (dBm)	Result
3	2422 MHz	19.60	30.00	Complies
6	2437 MHz	23.48	30.00	Complies
9	2452 MHz	21.46	30.00	Complies

For Two Chains:

Configuration of IEEE 802.11n (20MHz) Port 1

Channel	Frequency	Conducted Power (dBm)	Max. Limit (dBm)	Result
1	2412 MHz	19.62	30.00	Complies
6	2437 MHz	23.42	30.00	Complies
11	2462 MHz	21.61	30.00	Complies

Configuration of IEEE 802.11n (20MHz) Port 2

Channel	Frequency	Conducted Power (dBm)	Max. Limit (dBm)	Result
1	2412 MHz	19.59	30.00	Complies
6	2437 MHz	23.56	30.00	Complies
11	2462 MHz	21.65	30.00	Complies

Configuration of IEEE 802.11n (20MHz) Port 1+ Port 2

Channel	Frequency	Conducted Power (dBm)	Max. Limit (dBm)	Result
1	2412 MHz	22.62	30.00	Complies
6	2437 MHz	26.50	30.00	Complies
11	2462 MHz	24.64	30.00	Complies

Configuration of IEEE 802.11n (40MHz) Port 1

Channel	Frequency	Conducted Power (dBm)	Max. Limit (dBm)	Result
3	2422 MHz	19.59	30.00	Complies
6	2437 MHz	22.23	30.00	Complies
9	2452 MHz	19.72	30.00	Complies

Configuration of IEEE 802.11n (40MHz) Port 2

Channel	Frequency	Conducted Power (dBm)	Max. Limit (dBm)	Result
3	2422 MHz	19.88	30.00	Complies
6	2437 MHz	22.56	30.00	Complies
9	2452 MHz	19.71	30.00	Complies

Configuration of IEEE 802.11n (40MHz) Port 1+ Port 2

Channel	Frequency	Conducted Power (dBm)	Max. Limit (dBm)	Result
3	2422 MHz	22.75	30.00	Complies
6	2437 MHz	25.41	30.00	Complies
9	2452 MHz	22.73	30.00	Complies

3.3 Power Spectral Density Measurement

3.3.1 Limit

For digitally modulated systems, the power spectral density conducted from the intentional radiator to the antenna shall not be greater than 8 dBm in any 3 kHz band during any time interval of continuous transmission.

3.3.2 Measuring Instruments and Setting

Please refer to section 4 of equipments list in this report. The following table is the setting of the spectrum analyzer.

Spectrum Parameter	Setting
Attenuation	Auto
Span Frequency	1.5MHz
RB	3 kHz
VB	30 kHz
Detector	Peak
Trace	Max Hold
Sweep Time	500s

3.3.3 Test Procedures

1. The transmitter output (antenna port) was connected to the spectrum analyzer.
2. Set RBW of spectrum analyzer to 3kHz and VBW to 30kHz. Set Detector to Peak, Trace to Max Hold.
3. Mark the frequency with maximum peak power as the center of the display of the spectrum.
4. Set the span to 1.5MHz and the sweep time to 500s and record the maximum peak value.
5. When measuring maximum conducted output power within multiple antenna systems, add every result of the values by mathematic formula. (Only for IEEE 802.11n test)

3.3.4 Test Setup Layout

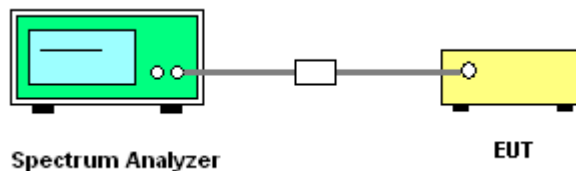

3.3.5 Test Deviation

There is no deviation with the original standard.

3.3.6 EUT Operation during Test

The EUT was programmed to be in continuously transmitting mode.

3.3.7 Test Result of Power Spectral Density

Final Test Date	Apr. 08, 2012	Test Site No.	TH01-HY
Temperature	23°C	Humidity	33%
Test Engineer	Shiming	Configurations	802.11b/g/n

For Single Chain:

Configuration IEEE 802.11b Port 1

Channel	Frequency	Power Density (dBm)	Max. Limit (dBm)	Result
1	2412 MHz	-6.54	8.00	Complies
6	2437 MHz	-6.97	8.00	Complies
11	2462 MHz	-6.40	8.00	Complies

Configuration IEEE 802.11g Port 1

Channel	Frequency	Power Density (dBm)	Max. Limit (dBm)	Result
1	2412 MHz	-10.25	8.00	Complies
6	2437 MHz	-8.50	8.00	Complies
11	2462 MHz	-11.25	8.00	Complies

Configuration of IEEE 802.11n (20MHz) Port 1

Channel	Frequency	Power Density (dBm)	Max. Limit (dBm)	Result
1	2412 MHz	-11.45	8.00	Complies
6	2437 MHz	-8.76	8.00	Complies
11	2462 MHz	-11.42	8.00	Complies

Configuration of IEEE 802.11n (40MHz) Port 1

Channel	Frequency	Power Density (dBm)	Max. Limit (dBm)	Result
3	2422 MHz	-16.32	8.00	Complies
6	2437 MHz	-11.99	8.00	Complies
9	2452 MHz	-15.62	8.00	Complies

For Two Chains:

Configuration of IEEE 802.11n (20MHz) Port 1

Channel	Frequency	Power Density (dBm)	Max. Limit (dBm)	Result
1	2412 MHz	-14.20	8.00	Complies
6	2437 MHz	-8.62	8.00	Complies
11	2462 MHz	-11.84	8.00	Complies

Configuration of IEEE 802.11n (20MHz) Port 2

Channel	Frequency	Power Density (dBm)	Max. Limit (dBm)	Result
1	2412 MHz	-14.51	8.00	Complies
6	2437 MHz	-9.67	8.00	Complies
11	2462 MHz	-12.56	8.00	Complies

Configuration of IEEE 802.11n (20MHz) Port 1+ Port 2

Channel	Frequency	Power Density (dBm)	Max. Limit (dBm)	Result
1	2412 MHz	-11.34	8.00	Complies
6	2437 MHz	-6.10	8.00	Complies
11	2462 MHz	-9.17	8.00	Complies

Configuration of IEEE 802.11n (40MHz) Port 1

Channel	Frequency	Power Density (dBm)	Max. Limit (dBm)	Result
3	2422 MHz	-16.92	8.00	Complies
6	2437 MHz	-15.83	8.00	Complies
9	2452 MHz	-18.38	8.00	Complies

Configuration of IEEE 802.11n (40MHz) Port 2

Channel	Frequency	Power Density (dBm)	Max. Limit (dBm)	Result
3	2422 MHz	-17.58	8.00	Complies
6	2437 MHz	-14.52	8.00	Complies
9	2452 MHz	-17.62	8.00	Complies

Configuration of IEEE 802.11n (40MHz) Port 1+ Port 2

Channel	Frequency	Power Density (dBm)	Max. Limit (dBm)	Result
3	2422 MHz	-14.23	8.00	Complies
6	2437 MHz	-12.12	8.00	Complies
9	2452 MHz	-14.97	8.00	Complies

For Single Chain:
Power Density Plot on Configuration IEEE 802.11b 2412 MHz Port 1

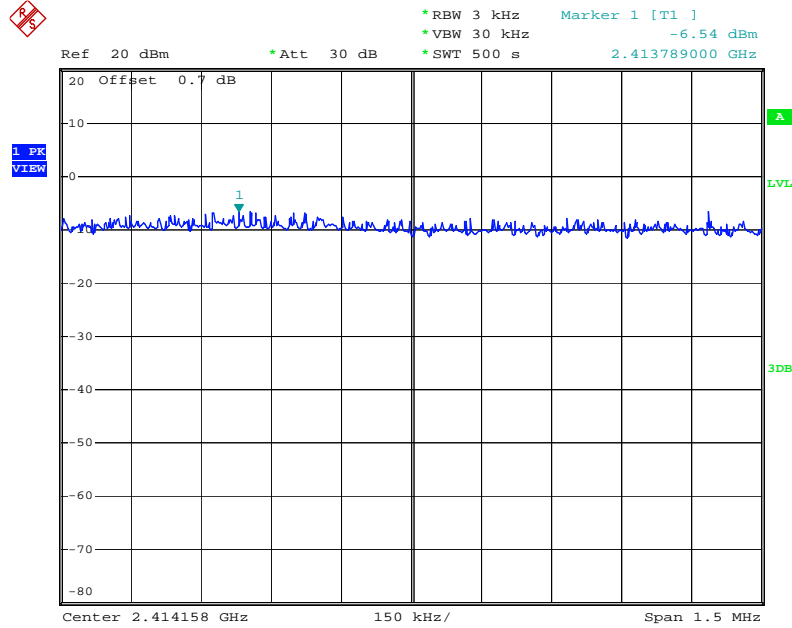

Date: 8.APR.2012 02:08:57

Power Density Plot on Configuration IEEE 802.11b 2437 MHz Port 1

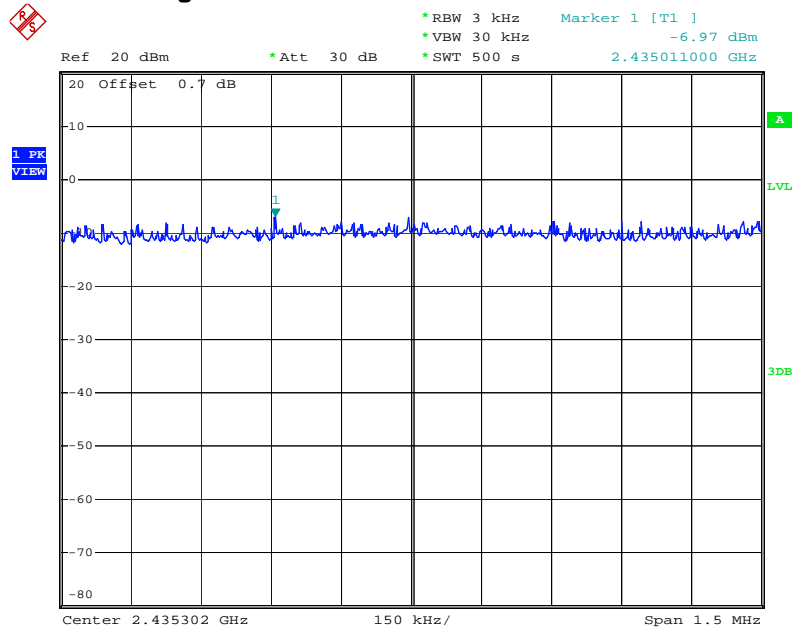

Date: 8.APR.2012 02:15:16

Power Density Plot on Configuration IEEE 802.11b 2462 MHz Port 1

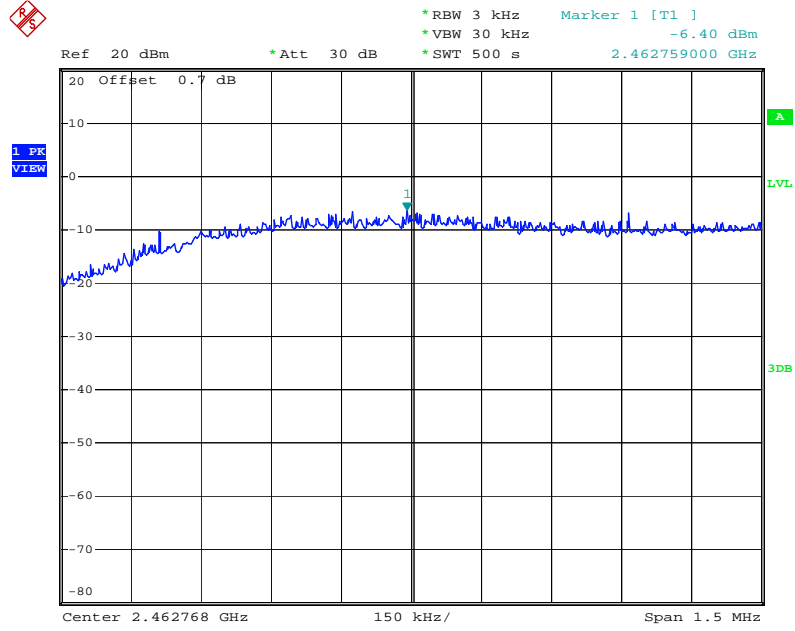

Date: 8.APR.2012 02:19:34

Power Density Plot on Configuration IEEE 802.11g 2412 MHz Port 1

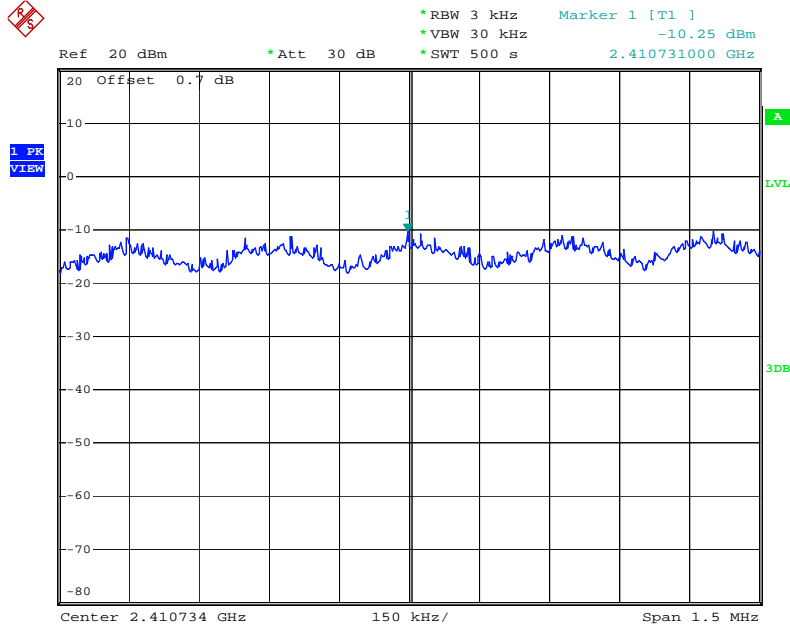

Date: 7.APR.2012 03:17:46

Power Density Plot on Configuration IEEE 802.11g 2437 MHz Port 1

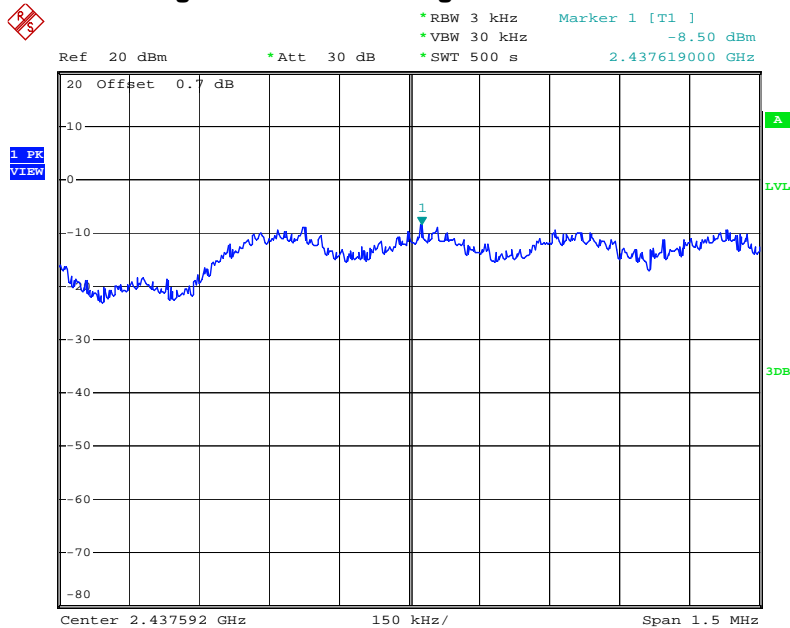

Date: 7.APR.2012 03:20:40

Power Density Plot on Configuration IEEE 802.11g 2462 MHz Port 1

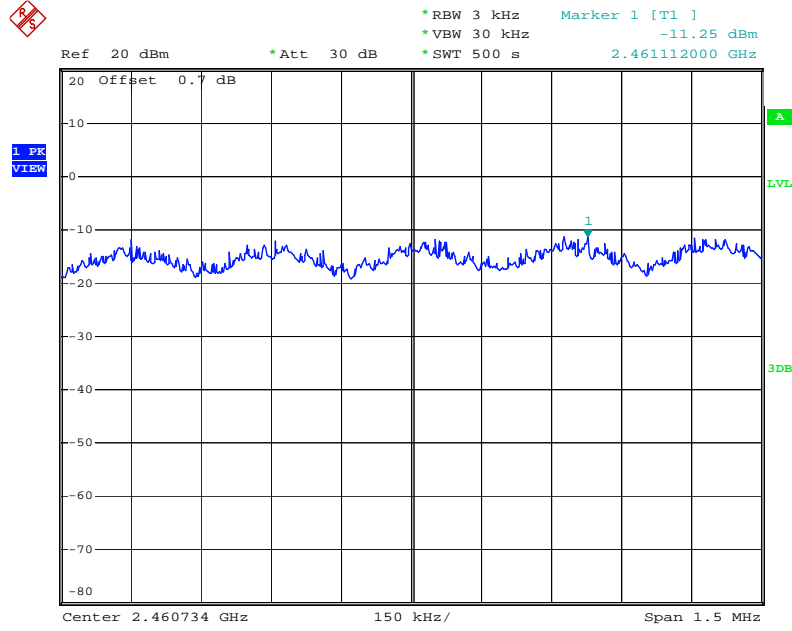

Date: 7.APR.2012 03:24:49

Power Density Plot on Configuration IEEE 802.11n (20MHz) 2412 MHz Port 1

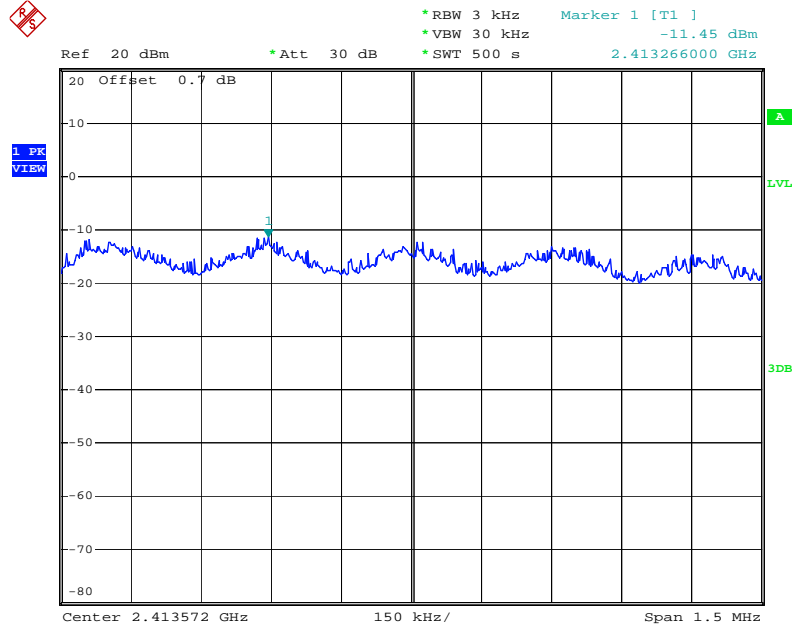

Date: 7.APR.2012 03:31:26

Power Density Plot on Configuration IEEE 802.11n (20MHz) 2437 MHz Port 1

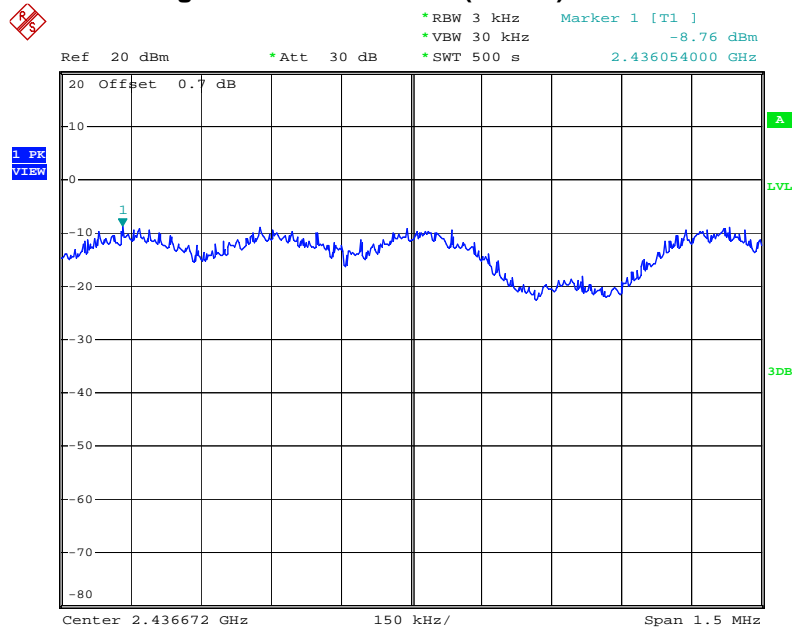

Date: 7.APR.2012 03:34:32

Power Density Plot on Configuration IEEE 802.11n (20MHz) 2462 MHz Port 1

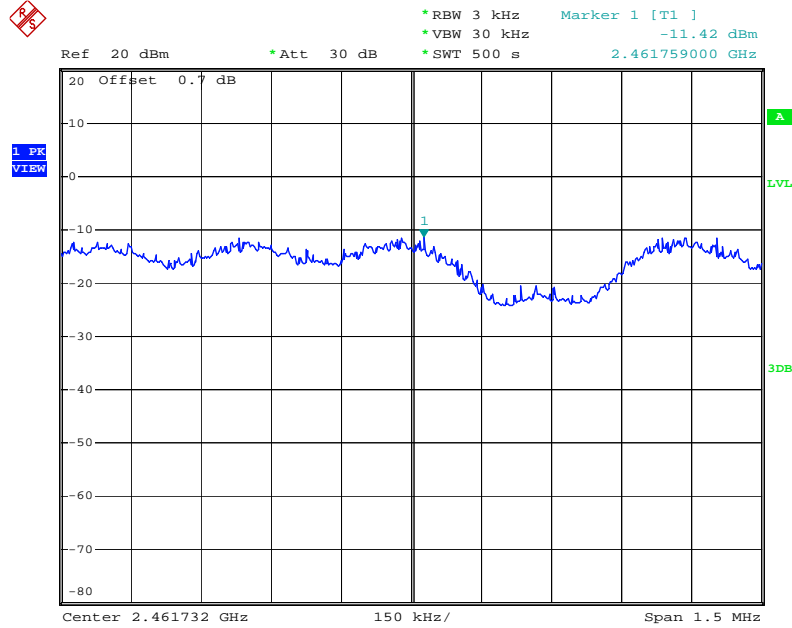

Date: 7.APR.2012 03:39:47

Power Density Plot on Configuration IEEE 802.11n (40MHz) 2422 MHz Port 1

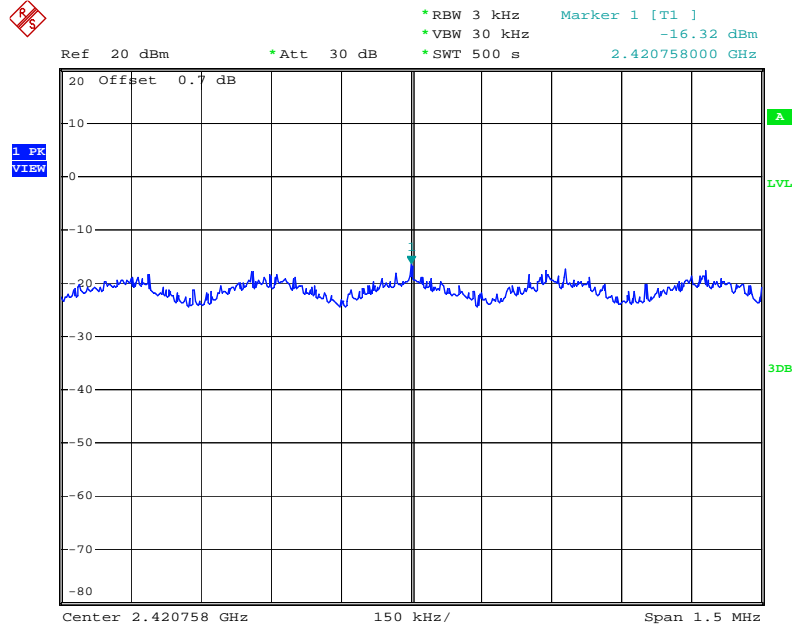

Date: 7.APR.2012 03:49:11

Power Density Plot on Configuration IEEE 802.11n (40MHz) 2437 MHz Port 1

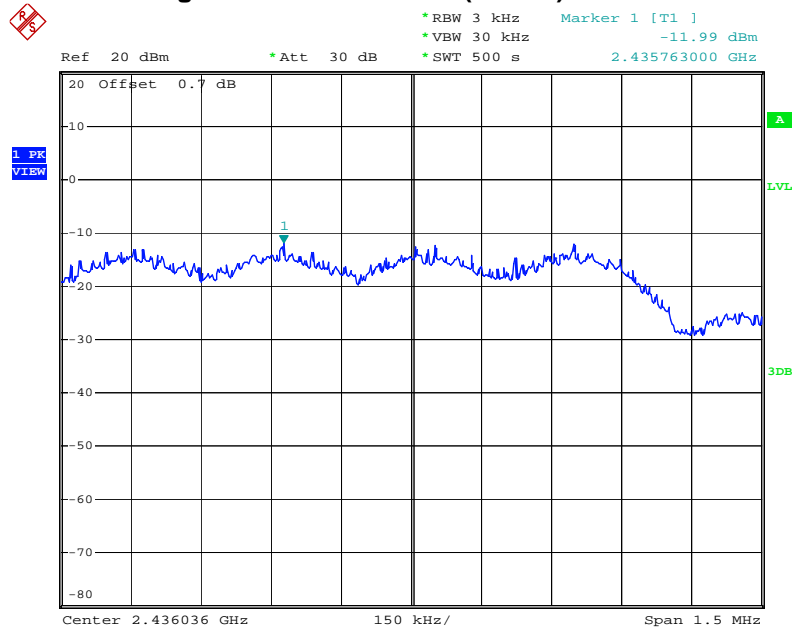

Date: 7.APR.2012 03:53:01

Power Density Plot on Configuration IEEE 802.11n (40MHz) 2452 MHz Port 1

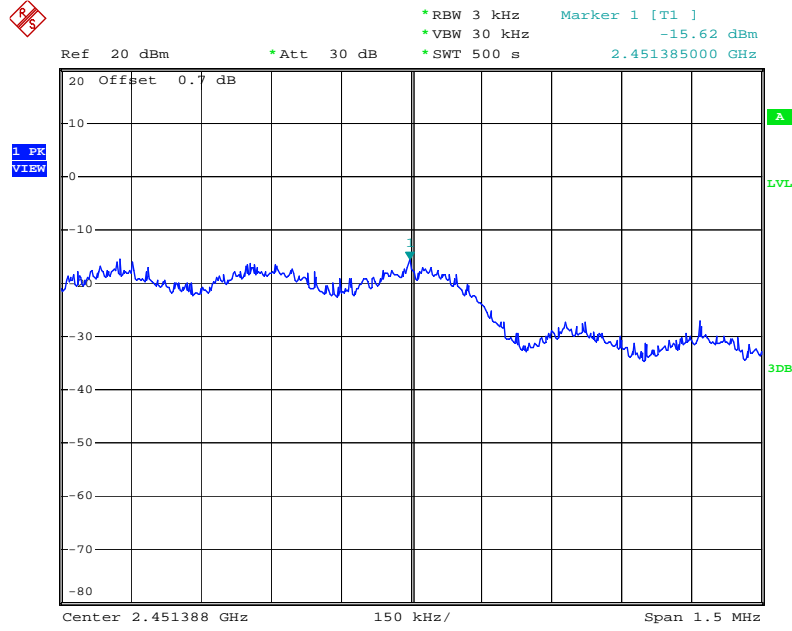

Date: 7.APR.2012 03:59:57

For Two Chains:
Power Density Plot on Configuration IEEE 802.11n (20MHz) 2412 MHz Port 1

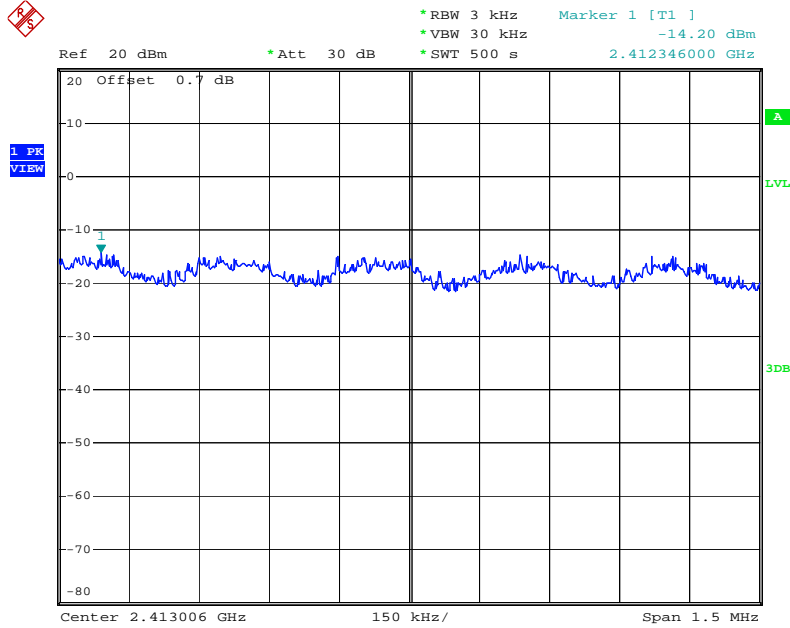

Date: 7.APR.2012 05:07:11

Power Density Plot on Configuration IEEE 802.11n (20MHz) 2437 MHz Port 1

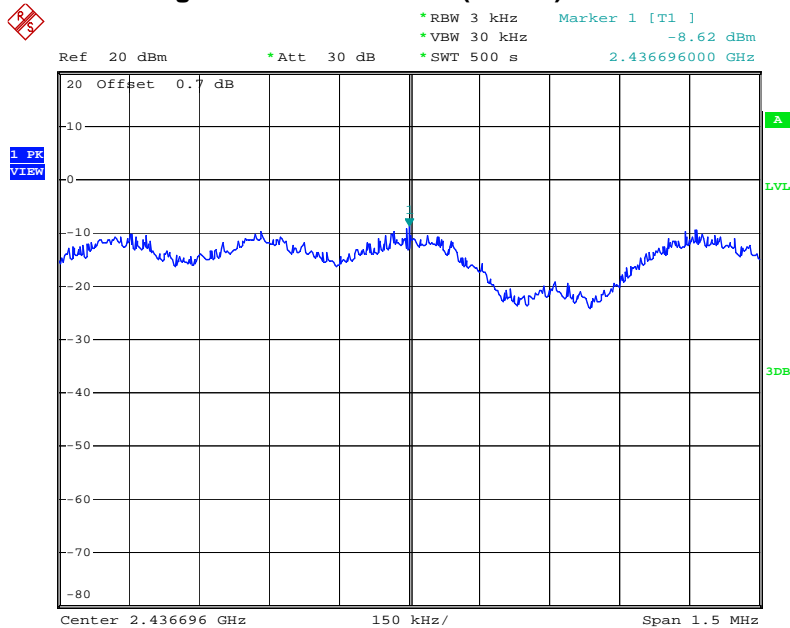

Date: 7.APR.2012 05:11:06

Power Density Plot on Configuration IEEE 802.11n (20MHz) 2462 MHz Port 1

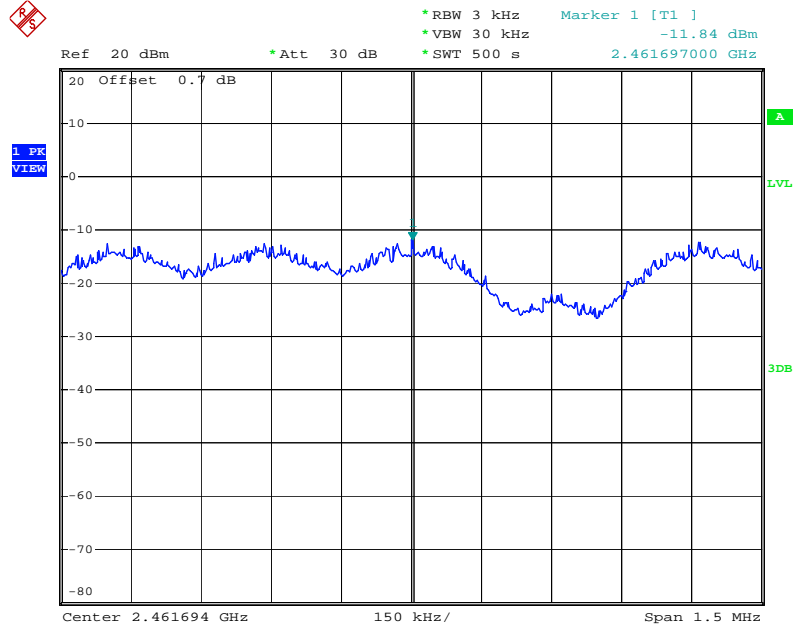

Date: 7.APR.2012 05:17:02

Power Density Plot on Configuration IEEE 802.11n (20MHz) 2412 MHz Port 2

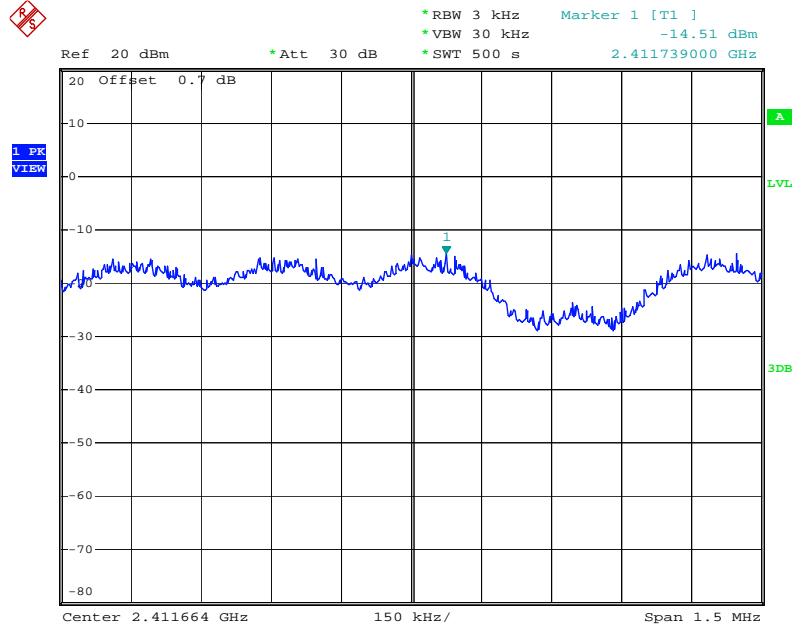

Date: 7.APR.2012 05:25:24

Power Density Plot on Configuration IEEE 802.11n (20MHz) 2437 MHz Port 2

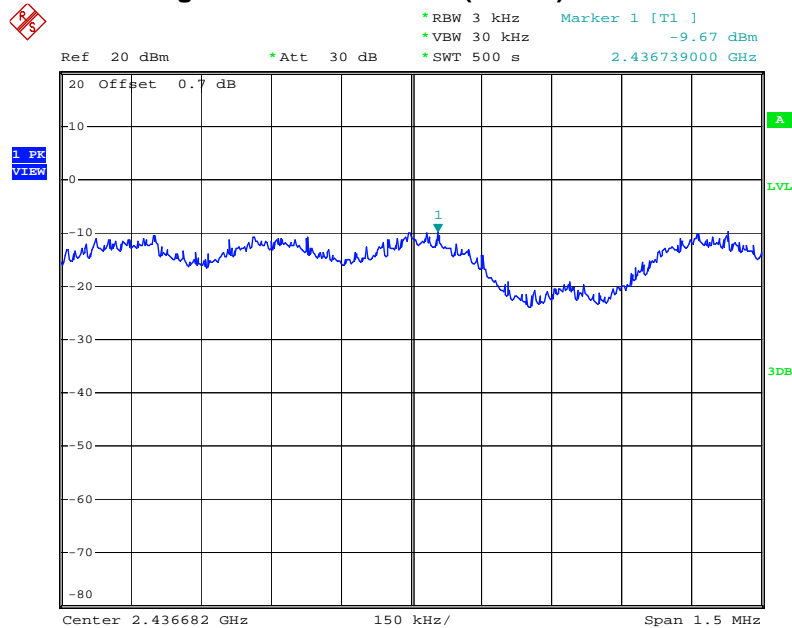

Date: 7.APR.2012 05:29:28

Power Density Plot on Configuration IEEE 802.11n (20MHz) 2462 MHz Port 2

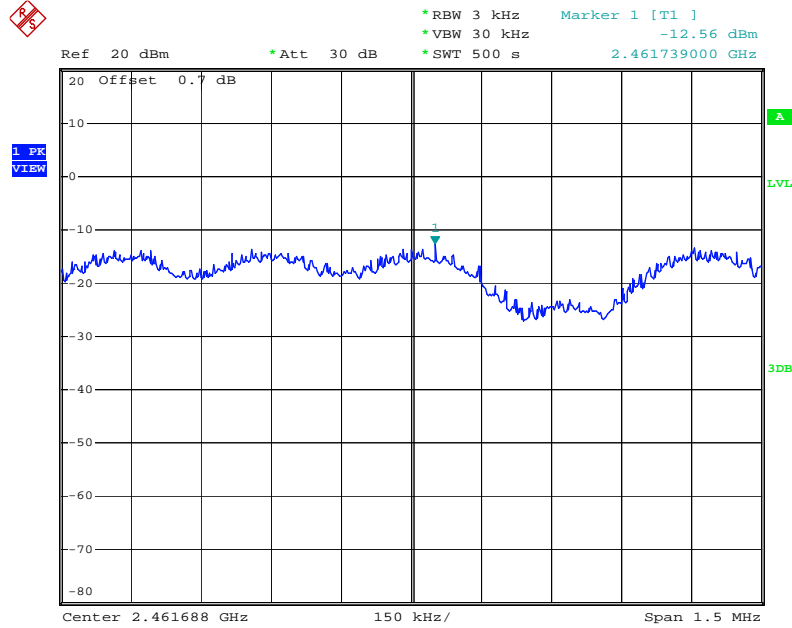

Date: 7.APR.2012 05:34:35

Power Density Plot on Configuration IEEE 802.11n (40MHz) 2422 MHz Port 1

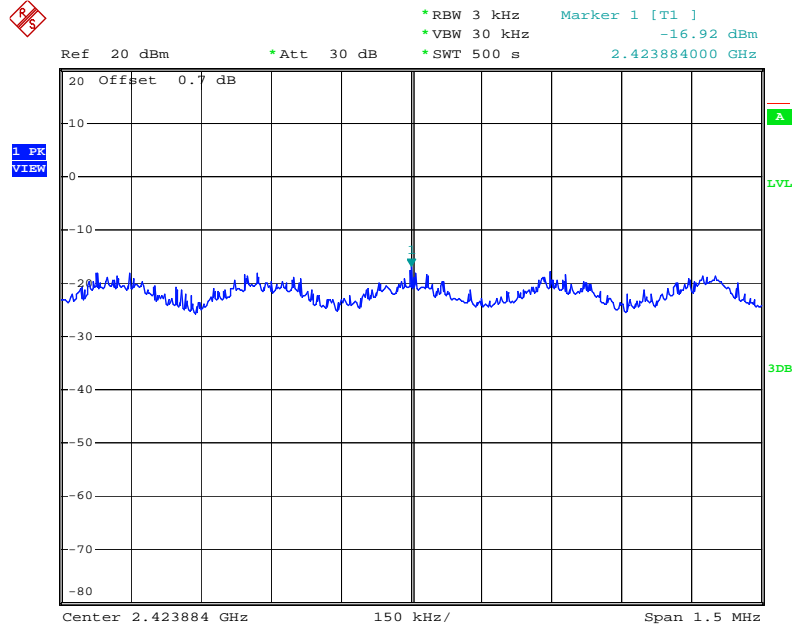

Date: 7.APR.2012 04:20:05

Power Density Plot on Configuration IEEE 802.11n (40MHz) 2437 MHz Port 1

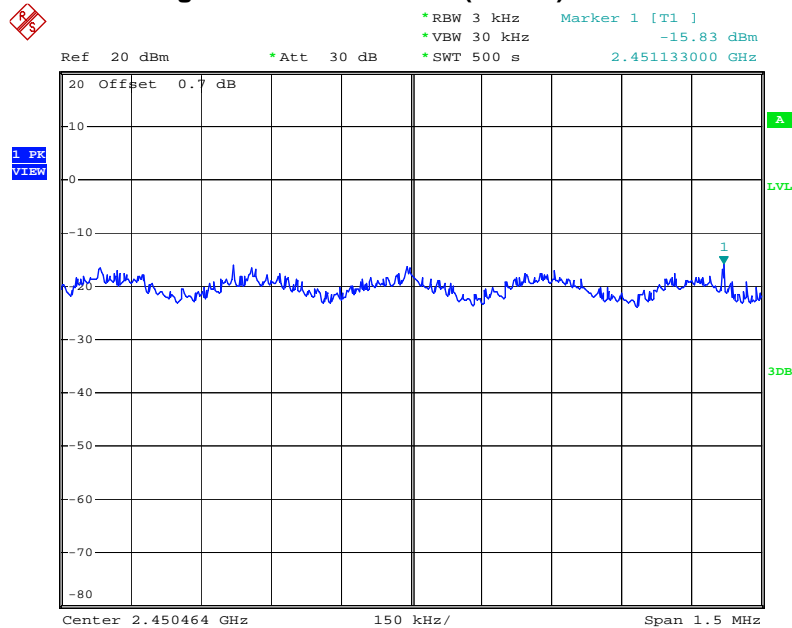

Date: 7.APR.2012 04:24:15

Power Density Plot on Configuration IEEE 802.11n (40MHz) 2452 MHz Port 1

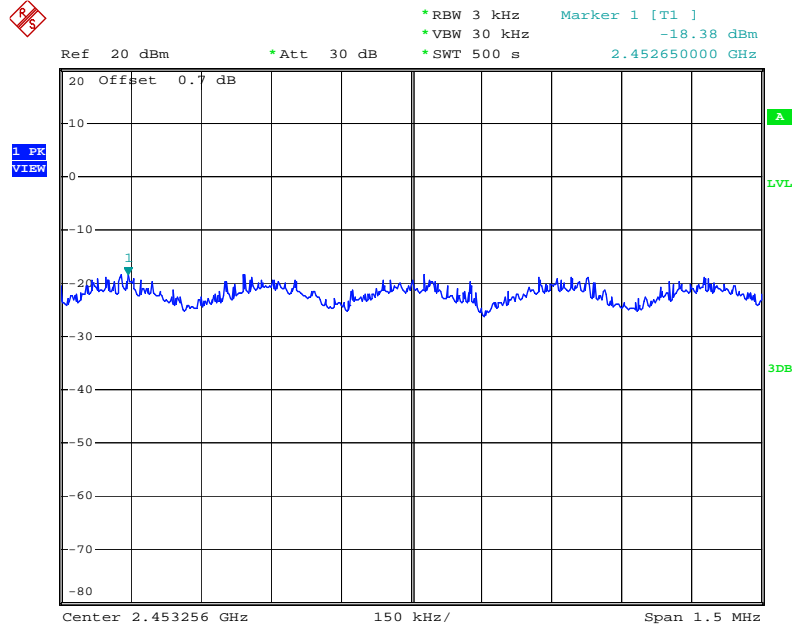

Date: 7.APR.2012 04:30:04

Power Density Plot on Configuration IEEE 802.11n (40MHz) 2422 MHz Port 2

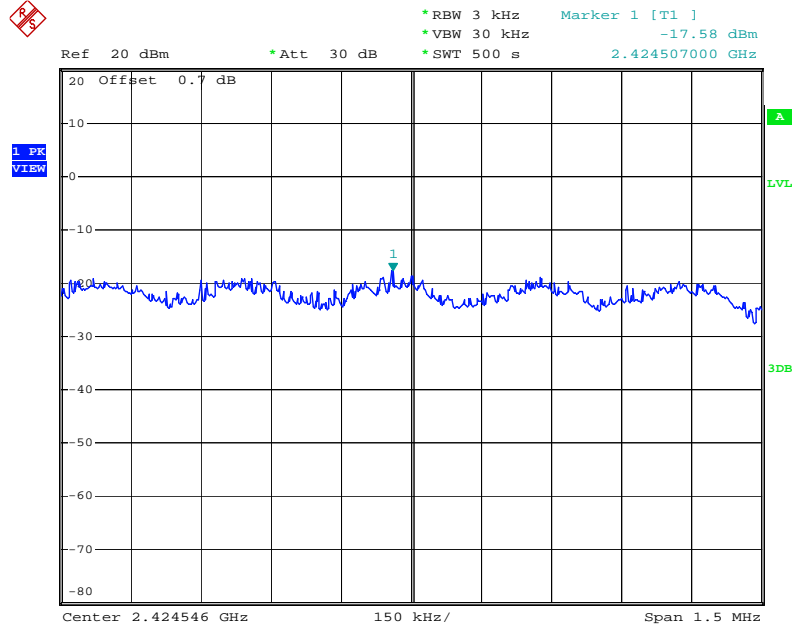

Date: 7.APR.2012 04:36:19

Power Density Plot on Configuration IEEE 802.11n (40MHz) 2437 MHz Port 2

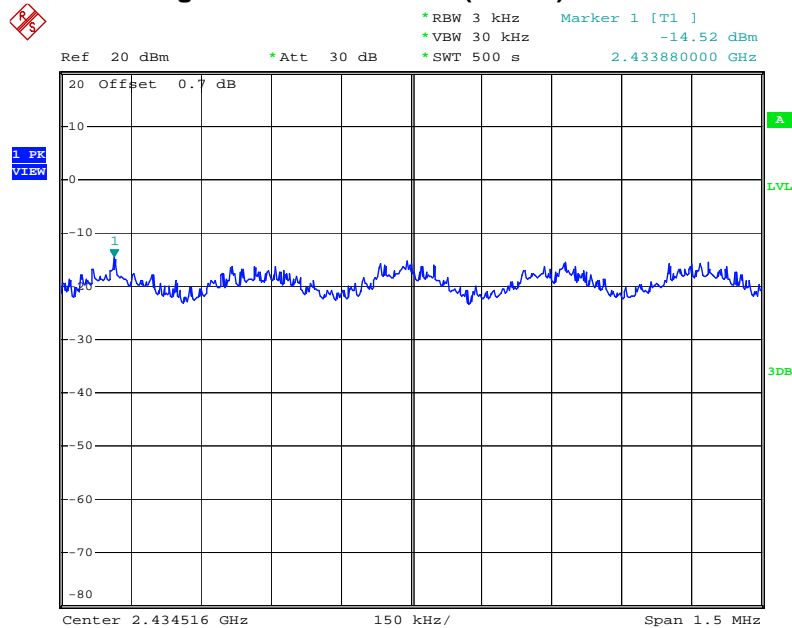

Date: 7.APR.2012 04:40:42

3.4 6dB Spectrum Bandwidth Measurement

3.4.1 Limit

For digital modulation systems, the minimum 6dB bandwidth shall be at least 500 kHz.

3.4.2 Measuring Instruments and Setting

Please refer to section 4 of equipments list in this report. The following table is the setting of the spectrum analyzer.

Spectrum Parameters	Setting
Attenuation	Auto
Span Frequency	> 6dB Bandwidth
RB	100 kHz
VB	300 kHz
Detector	Peak
Trace	Max Hold
Sweep Time	Auto

3.4.3 Test Procedures

1. The transmitter output (antenna port) was connected to the spectrum analyzer in peak hold mode.
2. For 6dB Bandwidth the resolution bandwidth of 100 kHz and the video bandwidth of 300 kHz were used.
3. Measured the spectrum width with power higher than 6dB below carrier.
4. For 99% Occupied Bandwidth the resolution Bandwidth of 100 kHz and the video bandwidth of 300 kHz were used.

3.4.4 Test Setup Layout

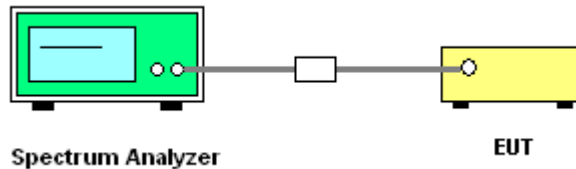

3.4.5 Test Deviation

There is no deviation with the original standard.

3.4.6 EUT Operation during Test

The EUT was programmed to be in continuously transmitting mode.

3.4.7 Test Result of 6dB Spectrum Bandwidth

Final Test Date	Apr. 08, 2012	Test Site No.	TH01-HY
Temperature	23°C	Humidity	33%
Test Engineer	Shiming	Configurations	802.11b/g/n

For Single Chain:

Configuration IEEE 802.11b Port 1

Channel	Frequency	6dB Bandwidth (MHz)	99% Occupied Bandwidth (MHz)	Min. Limit (kHz)	Test Result
1	2412 MHz	8.60	10.32	500	Complies
6	2437 MHz	8.60	10.32	500	Complies
11	2462 MHz	8.56	10.24	500	Complies

Configuration IEEE 802.11g Port 1

Channel	Frequency	6dB Bandwidth (MHz)	99% Occupied Bandwidth (MHz)	Min. Limit (kHz)	Test Result
1	2412 MHz	15.16	16.36	500	Complies
6	2437 MHz	15.16	16.36	500	Complies
11	2462 MHz	15.16	16.36	500	Complies

Configuration of IEEE 802.11n (20MHz) Port 1

Channel	Frequency	6dB Bandwidth (MHz)	99% Occupied Bandwidth (MHz)	Min. Limit (kHz)	Test Result
1	2412 MHz	16.08	17.48	500	Complies
6	2437 MHz	15.16	17.48	500	Complies
11	2462 MHz	16.08	17.48	500	Complies

Configuration of IEEE 802.11n (40MHz) Port 1

Channel	Frequency	6dB Bandwidth (MHz)	99% Occupied Bandwidth (MHz)	Min. Limit (kHz)	Test Result
3	2422 MHz	36.00	36.24	500	Complies
6	2437 MHz	36.16	36.24	500	Complies
9	2452 MHz	36.16	36.16	500	Complies

For Two Chains:

Configuration of IEEE 802.11n (20MHz) Port 1

Channel	Frequency	6dB Bandwidth (MHz)	99% Occupied Bandwidth (MHz)	Min. Limit (kHz)	Test Result
1	2412 MHz	16.08	17.48	500	Complies
6	2437 MHz	16.08	17.48	500	Complies
11	2462 MHz	16.08	17.48	500	Complies

Configuration of IEEE 802.11n (20MHz) Port 2

Channel	Frequency	6dB Bandwidth (MHz)	99% Occupied Bandwidth (MHz)	Min. Limit (kHz)	Test Result
1	2412 MHz	17.12	17.48	500	Complies
6	2437 MHz	16.92	17.48	500	Complies
11	2462 MHz	16.92	17.48	500	Complies

Configuration of IEEE 802.11n (40MHz) Port 1

Channel	Frequency	6dB Bandwidth (MHz)	99% Occupied Bandwidth (MHz)	Min. Limit (kHz)	Test Result
3	2422 MHz	36.40	36.24	500	Complies
6	2437 MHz	36.40	36.24	500	Complies
9	2452 MHz	36.40	36.24	500	Complies

Configuration of IEEE 802.11n (40MHz) Port 2

Channel	Frequency	6dB Bandwidth (MHz)	99% Occupied Bandwidth (MHz)	Min. Limit (kHz)	Test Result
3	2422 MHz	36.40	36.24	500	Complies
6	2437 MHz	36.40	36.24	500	Complies
9	2452 MHz	36.40	36.24	500	Complies

For Single Chain:
6 dB Bandwidth Plot on Configuration IEEE 802.11b 2412 MHz Port 1

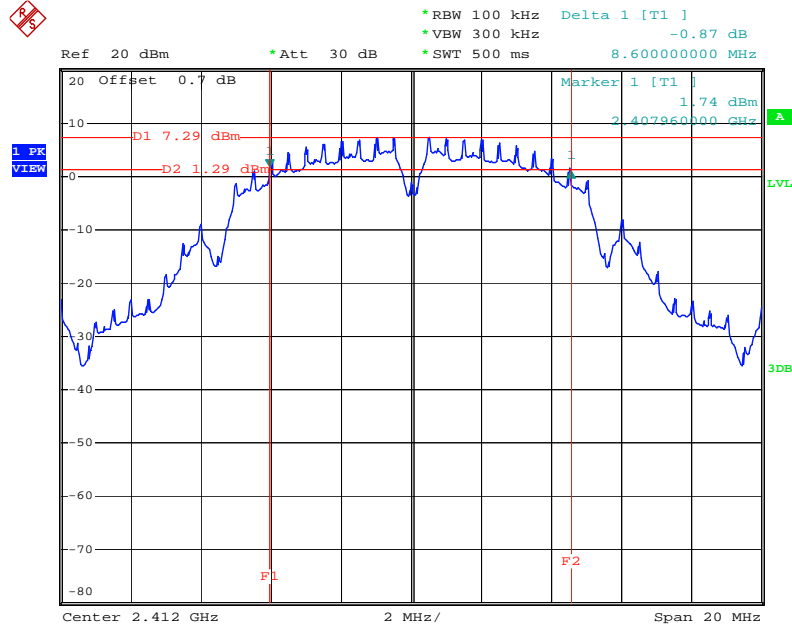

Date: 8.APR.2012 02:05:45

6 dB Bandwidth Plot on Configuration IEEE 802.11b 2437 MHz Port 1

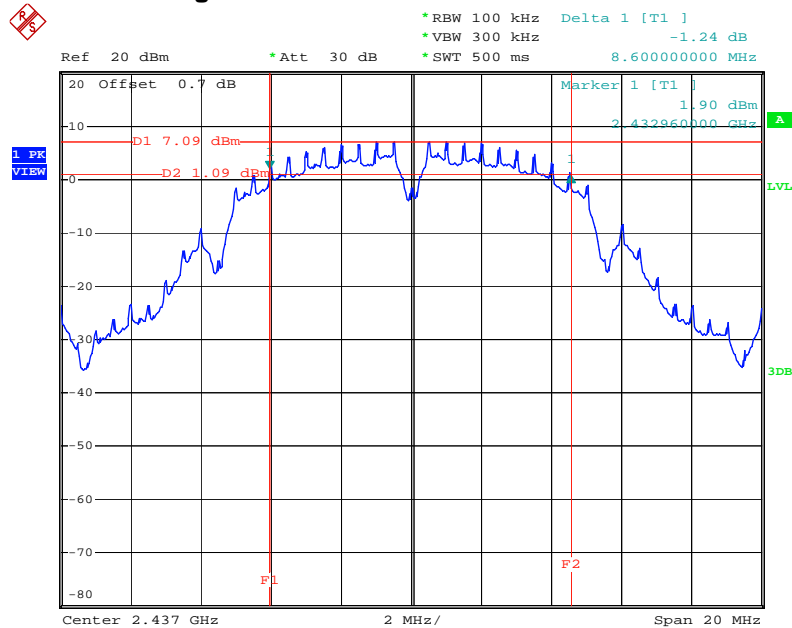

Date: 8.APR.2012 02:10:35

6 dB Bandwidth Plot on Configuration IEEE 802.11b 2462 MHz Port 1

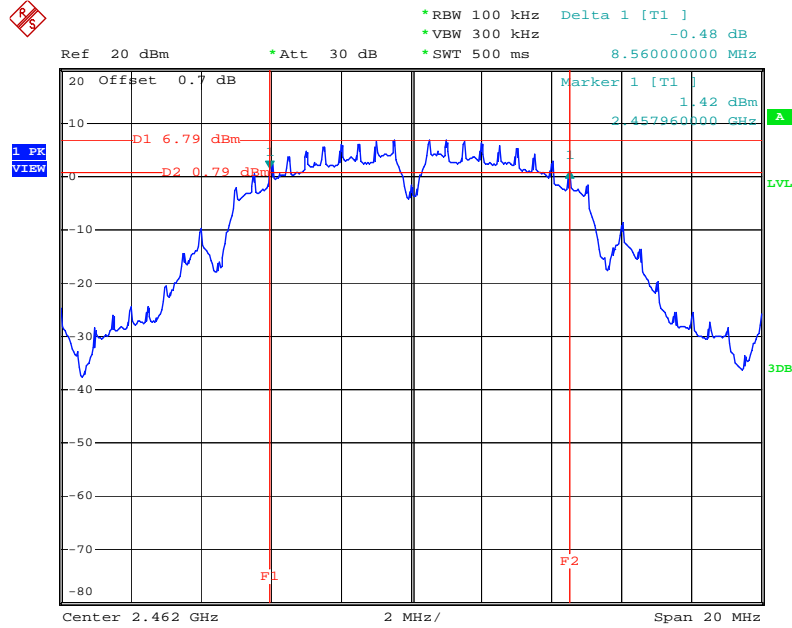

Date: 8.APR.2012 02:16:26

6 dB Bandwidth Plot on Configuration IEEE 802.11g 2412 MHz Port 1

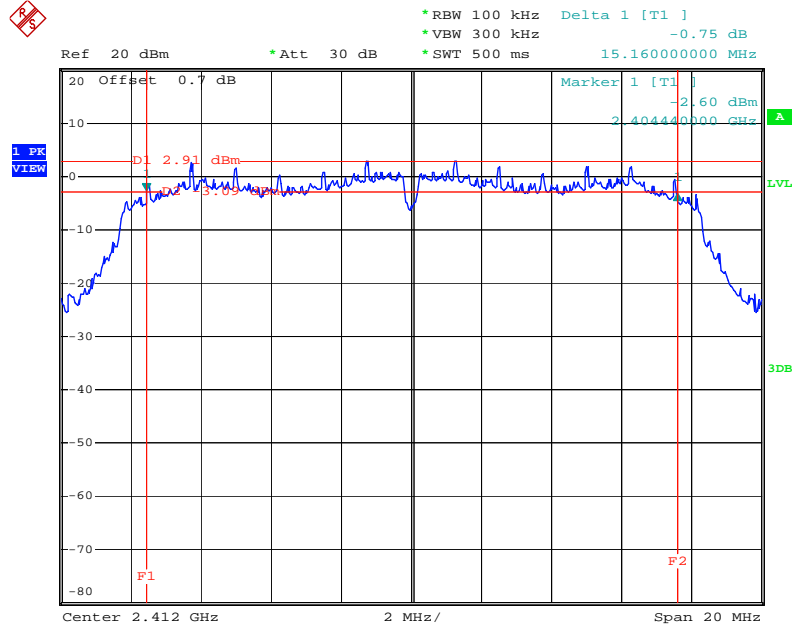

Date: 7.APR.2012 03:14:34

6 dB Bandwidth Plot on Configuration IEEE 802.11g 2437 MHz Port 1

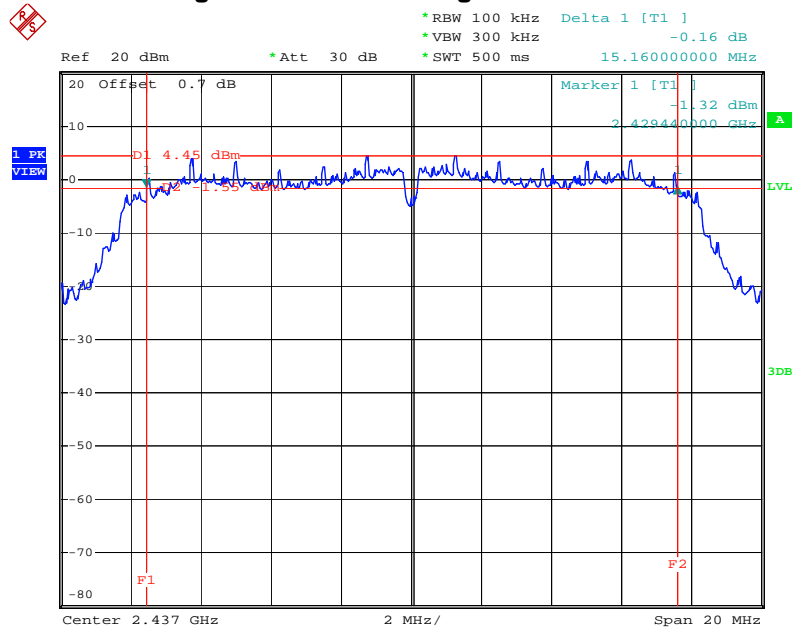

Date: 7.APR.2012 03:19:11

6 dB Bandwidth Plot on Configuration IEEE 802.11g 2462 MHz Port 1

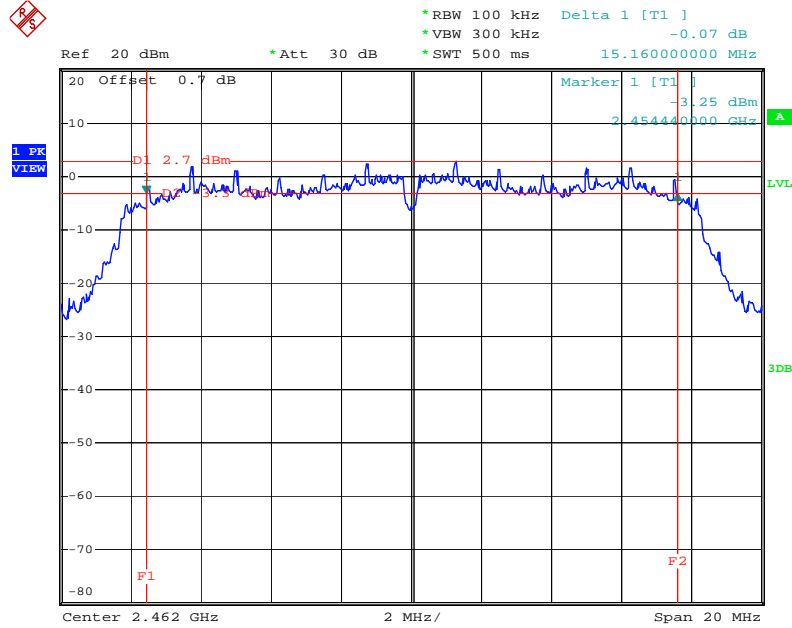

Date: 7.APR.2012 03:22:00

6 dB Bandwidth Plot on Configuration IEEE 802.11n (20MHz) 2412 MHz Port 1

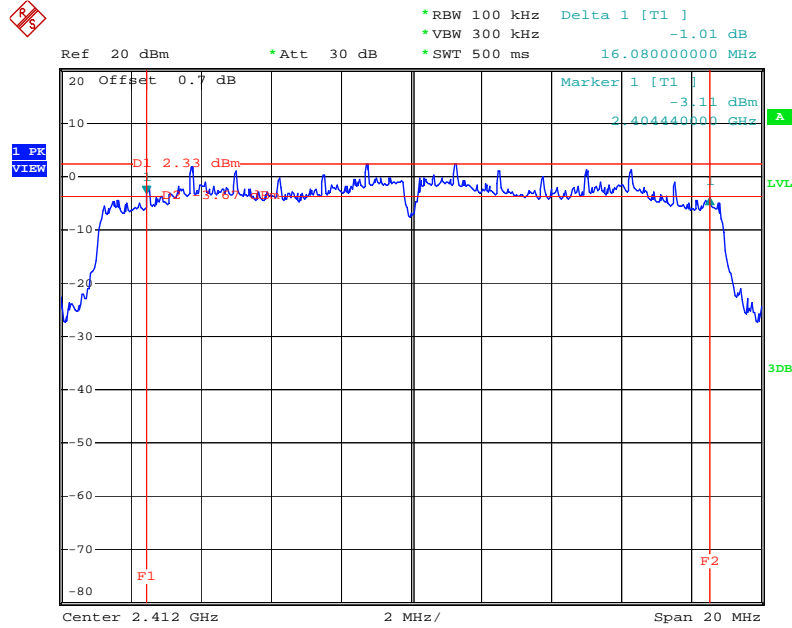

Date: 7.APR.2012 03:28:24

6 dB Bandwidth Plot on Configuration IEEE 802.11n (20MHz) 2437 MHz Port 1

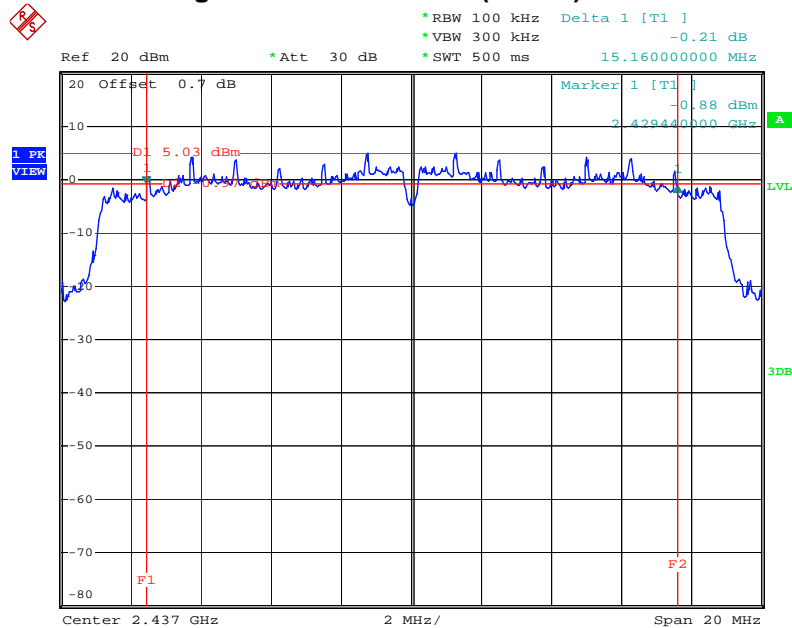

Date: 7.APR.2012 03:32:48

6 dB Bandwidth Plot on Configuration IEEE 802.11n (20MHz) 2462 MHz Port 1

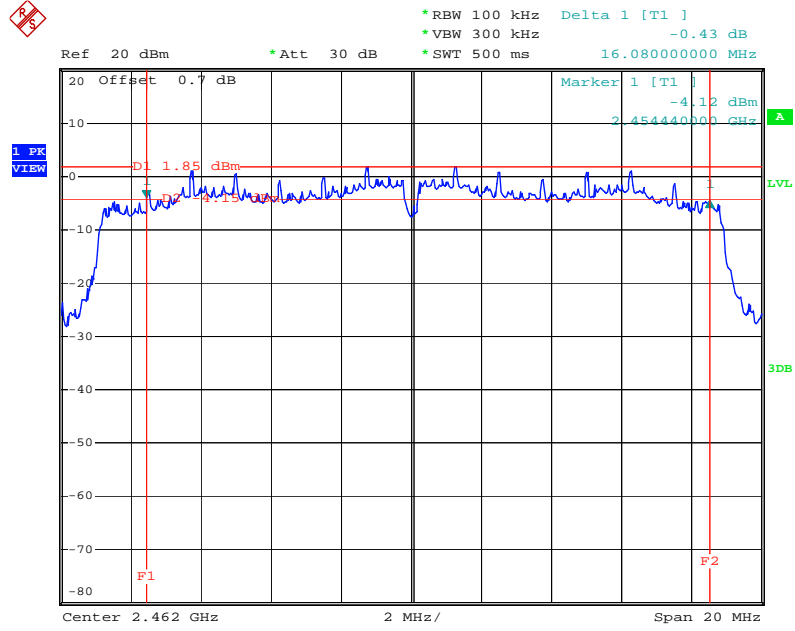

Date: 7.APR.2012 03:35:55

6 dB Bandwidth Plot on Configuration IEEE 802.11n (40MHz) 2422 MHz Port 1

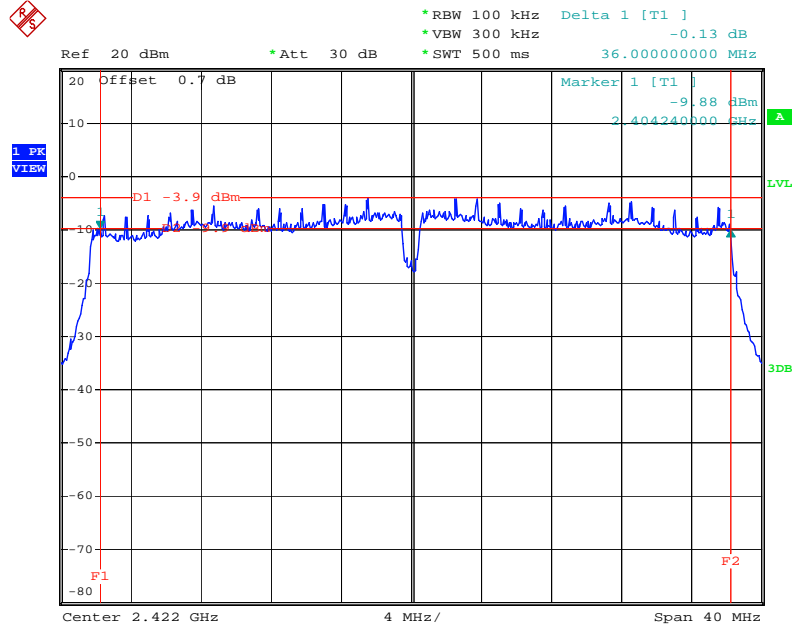

Date: 7.APR.2012 03:45:19

6 dB Bandwidth Plot on Configuration IEEE 802.11n (40MHz) 2437 MHz Port 1

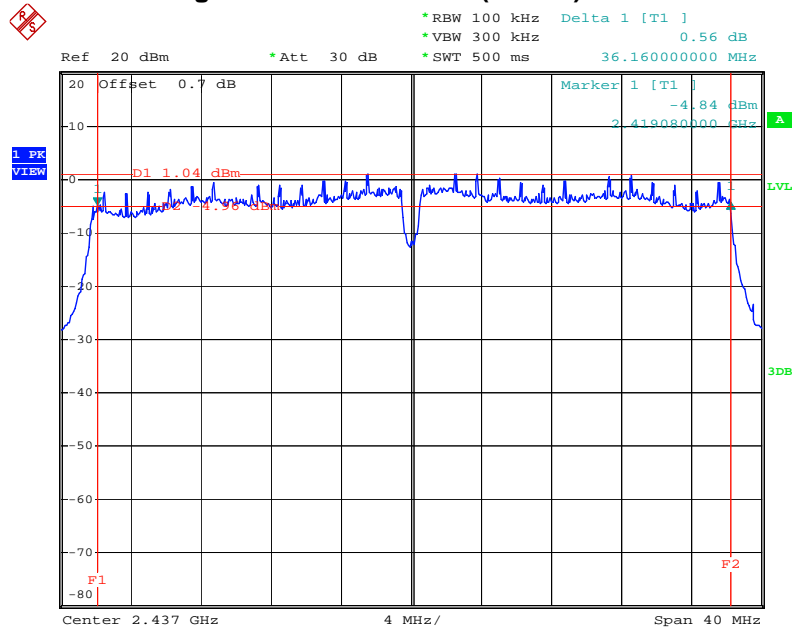

Date: 7.APR.2012 03:50:50

6 dB Bandwidth Plot on Configuration IEEE 802.11n (40MHz) 2452 MHz Port 1

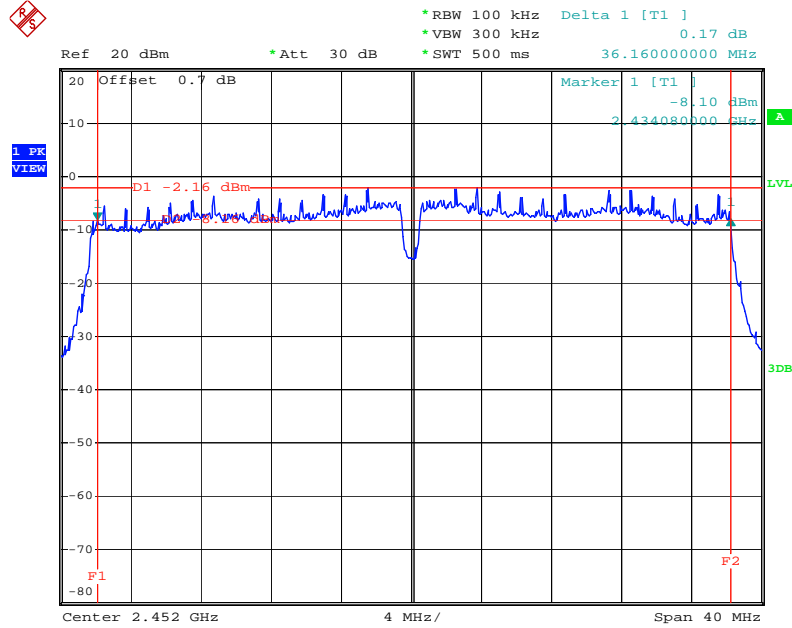

Date: 7.APR.2012 03:55:27

For Two Chains:
6 dB Bandwidth Plot on Configuration IEEE 802.11n (20MHz) 2412 MHz Port 1

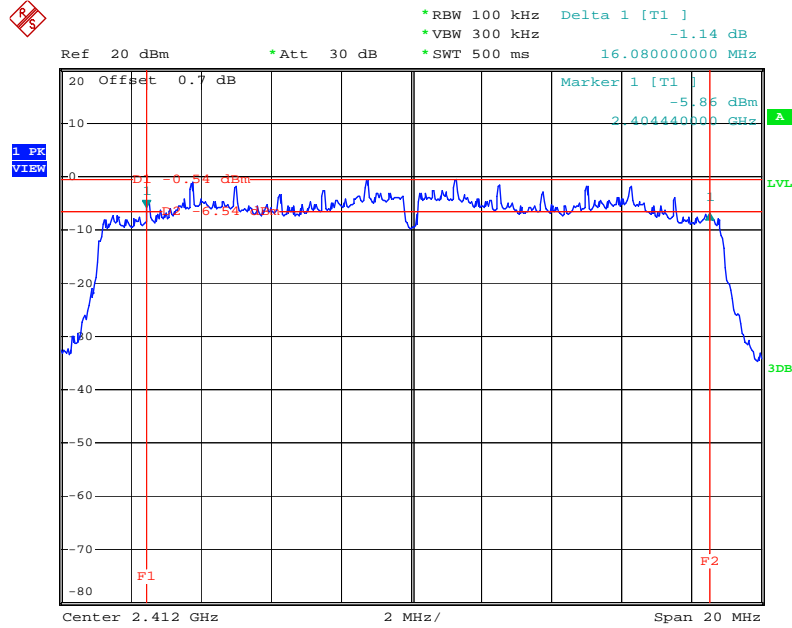

Date: 7.APR.2012 05:04:31

6 dB Bandwidth Plot on Configuration IEEE 802.11n (20MHz) 2437 MHz Port 1

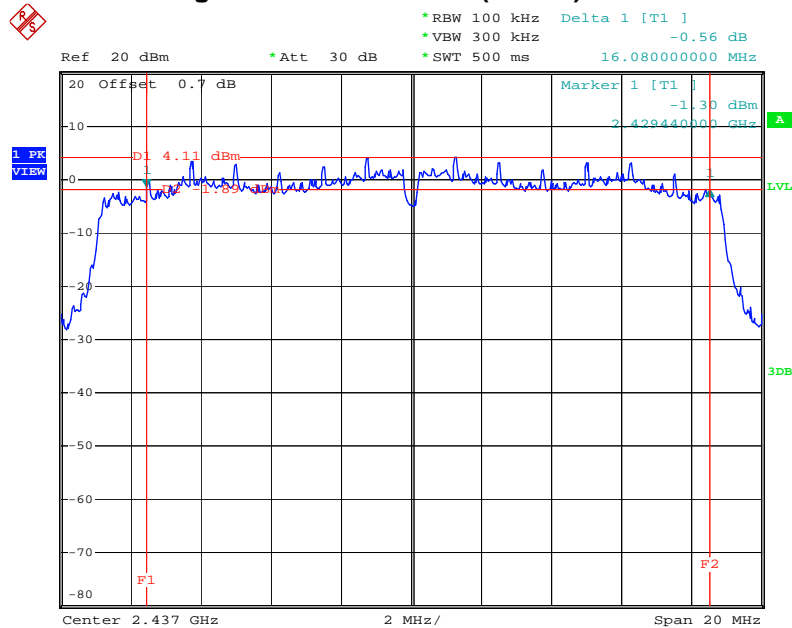

Date: 7.APR.2012 05:08:45

6 dB Bandwidth Plot on Configuration IEEE 802.11n (20MHz) 2462 MHz Port 1

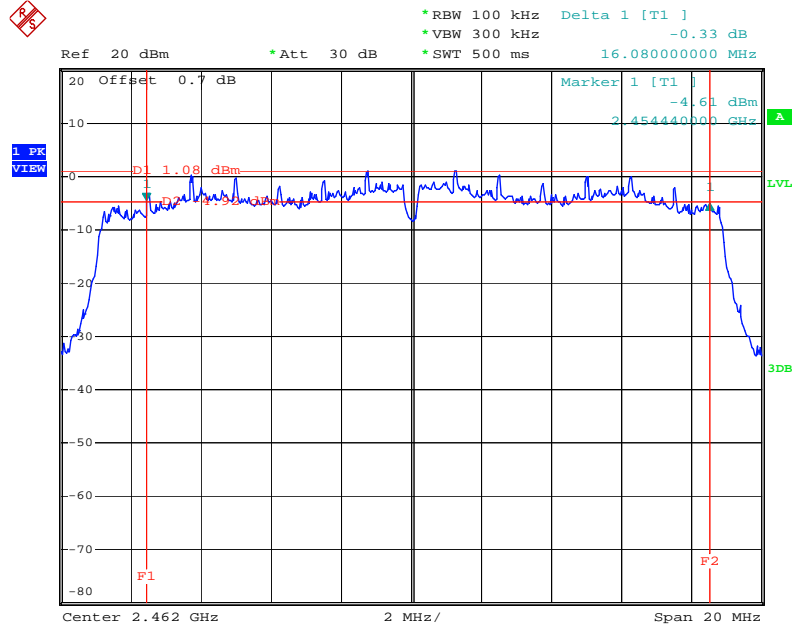

Date: 7.APR.2012 05:13:24

6 dB Bandwidth Plot on Configuration IEEE 802.11n (20MHz) 2412 MHz Port 2

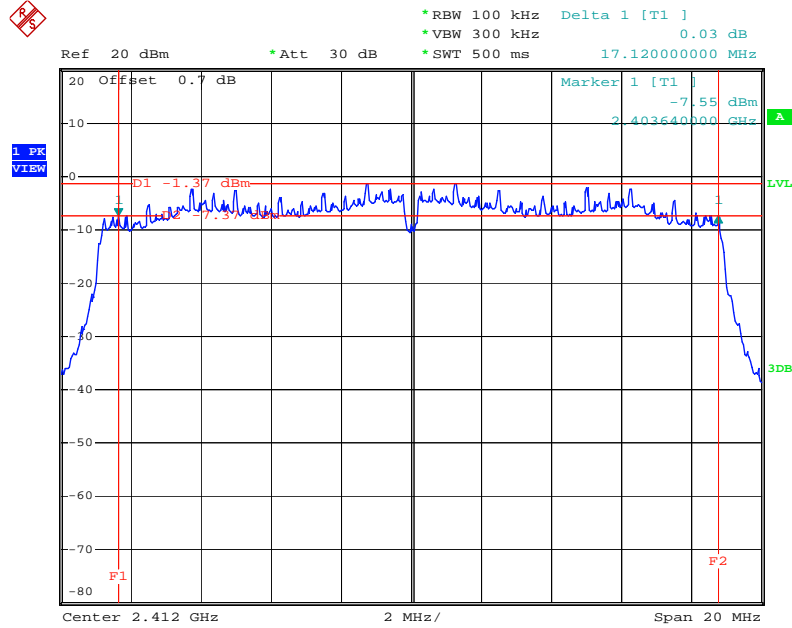

Date: 7.APR.2012 05:20:00

6 dB Bandwidth Plot on Configuration IEEE 802.11n (20MHz) 2437 MHz Port 2

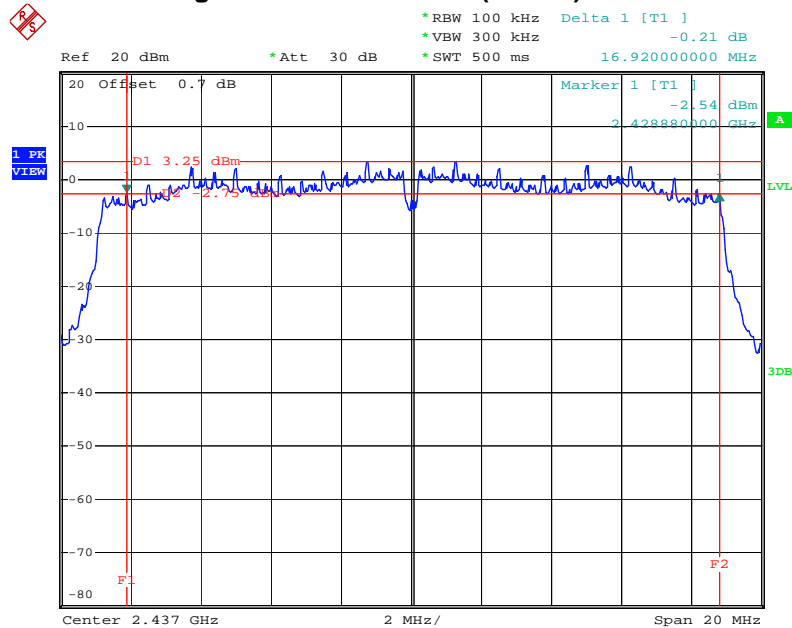

Date: 7.APR.2012 05:27:22

6 dB Bandwidth Plot on Configuration IEEE 802.11n (40MHz) 2422 MHz Port 1

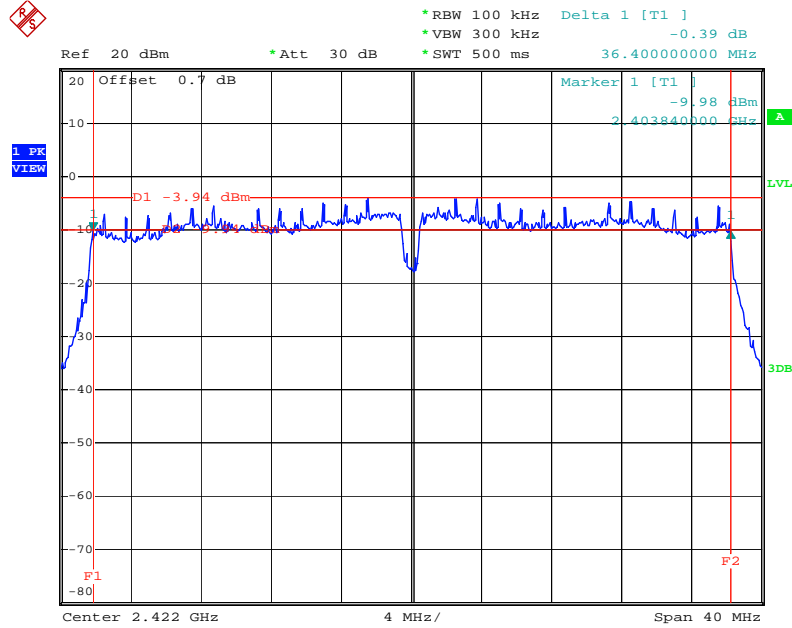

Date: 7.APR.2012 04:14:46

6 dB Bandwidth Plot on Configuration IEEE 802.11n (40MHz) 2437 MHz Port 1

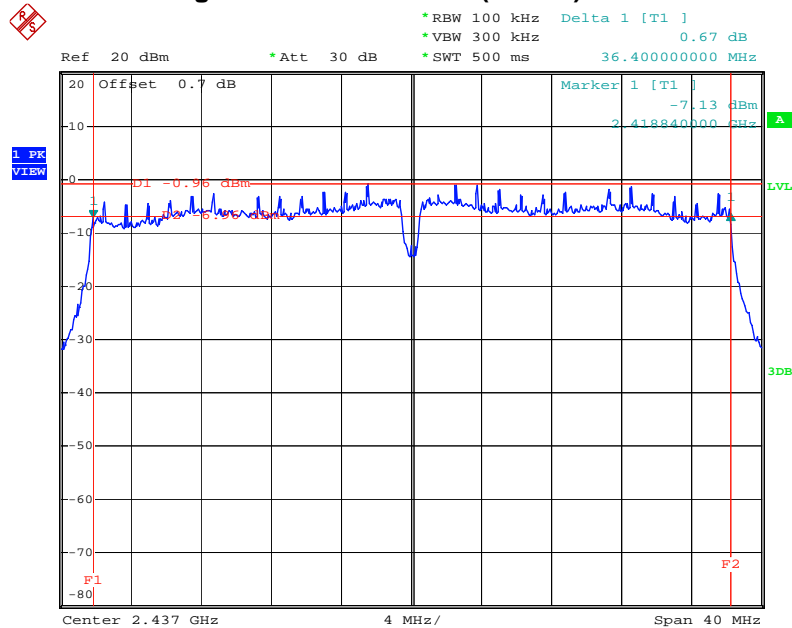

Date: 7.APR.2012 04:21:58

6 dB Bandwidth Plot on Configuration IEEE 802.11n (40MHz) 2452 MHz Port 1

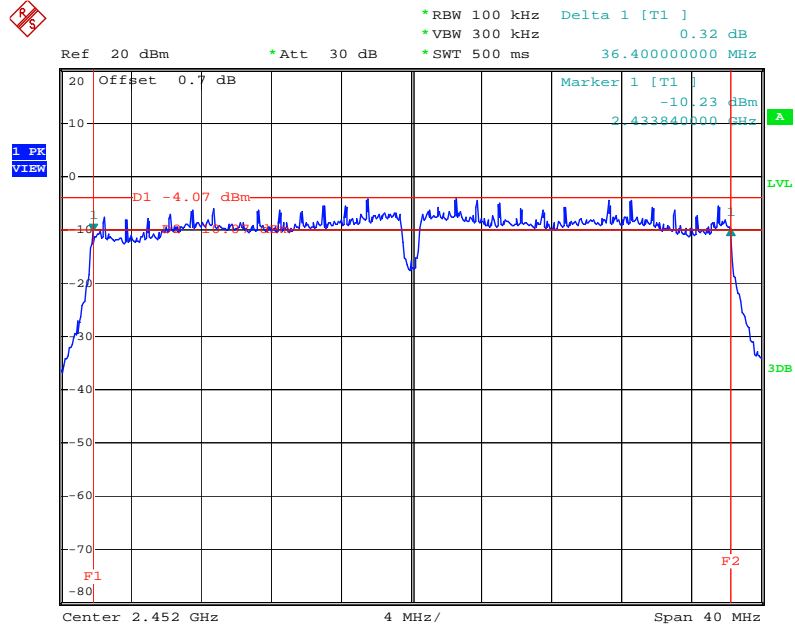

Date: 7.APR.2012 04:26:30

6 dB Bandwidth Plot on Configuration IEEE 802.11n (40MHz) 2422 MHz Port 2

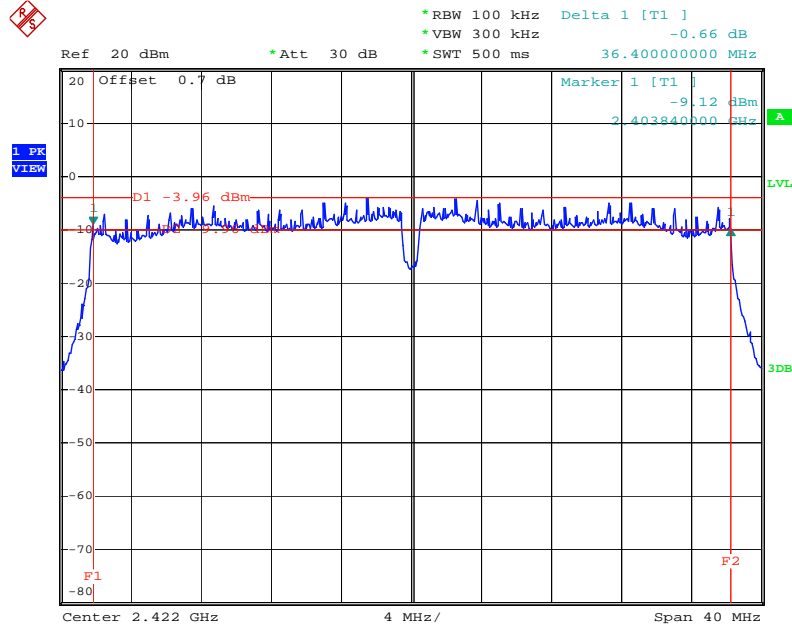

Date: 7.APR.2012 04:32:58

6 dB Bandwidth Plot on Configuration IEEE 802.11n (40MHz) 2437 MHz Port 2

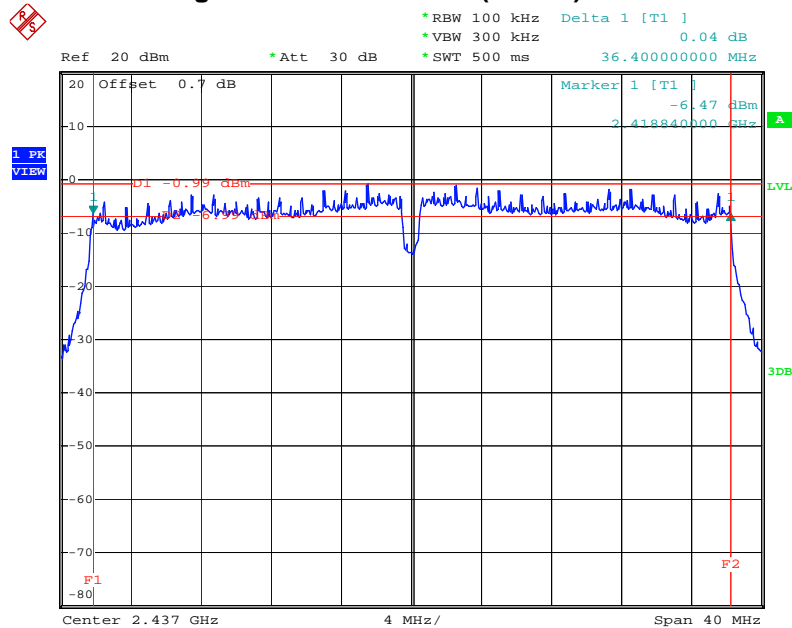

Date: 7.APR.2012 04:37:54

6 dB Bandwidth Plot on Configuration IEEE 802.11n (40MHz) 2452 MHz Port 2

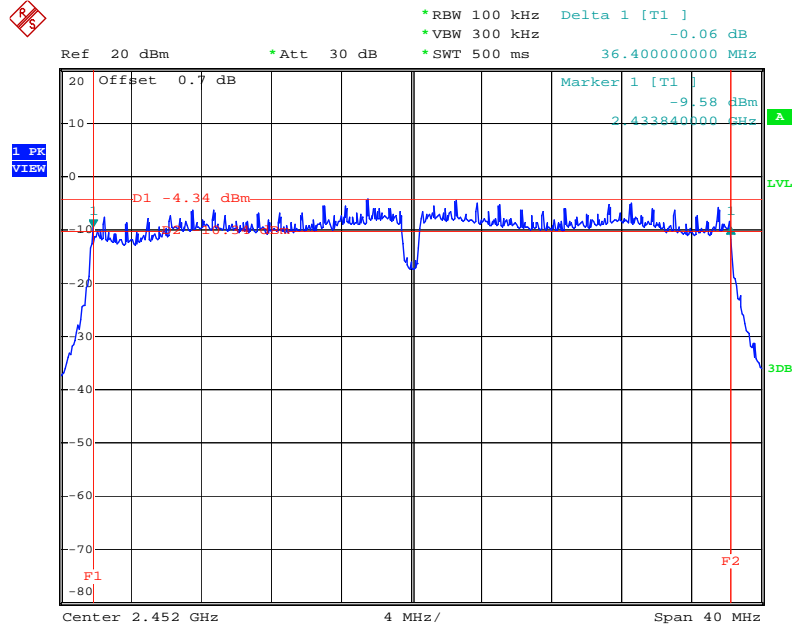

Date: 7.APR.2012 04:42:26

For Single Chain:
99% Occupied Bandwidth Plot on Configuration IEEE 802.11b 2412 MHz Port 1

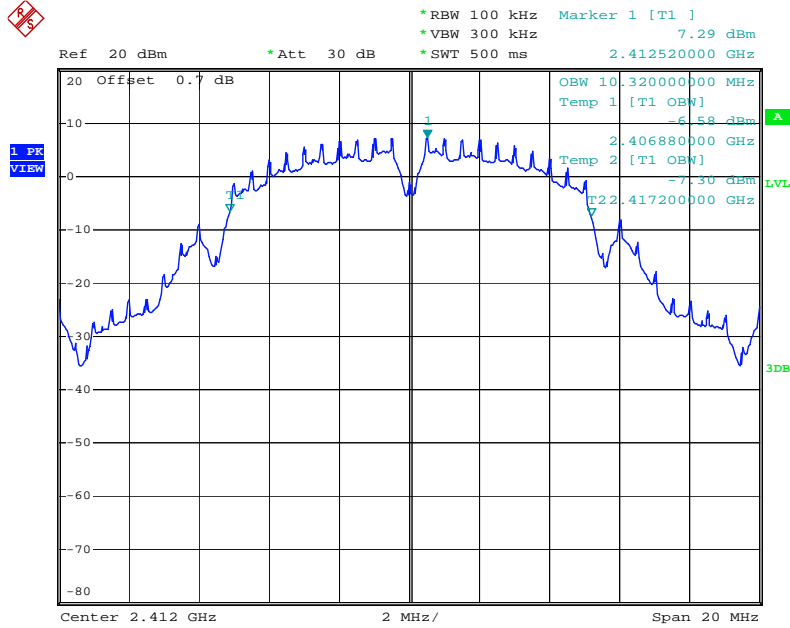

Date: 8.APR.2012 02:05:52

99% Occupied Bandwidth Plot on Configuration IEEE 802.11b 2437 MHz Port 1

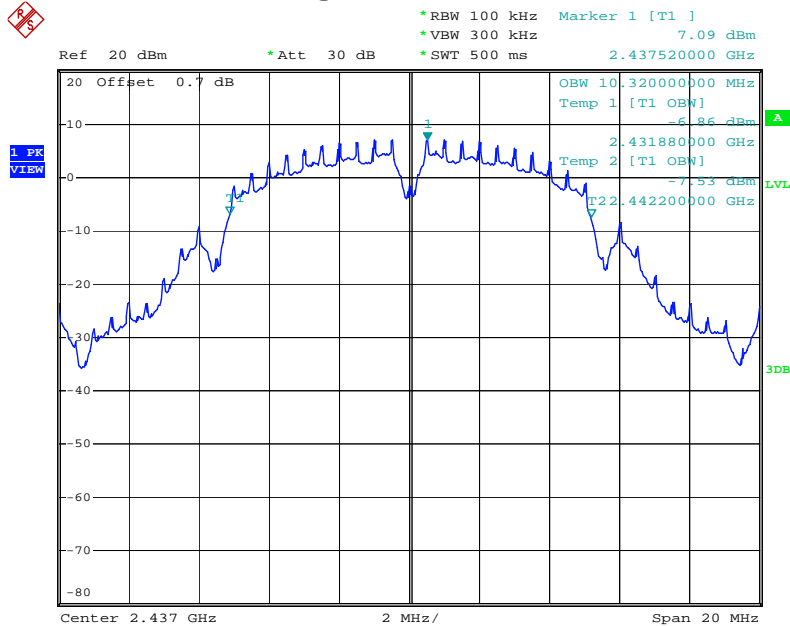

Date: 8.APR.2012 02:10:43

99% Occupied Bandwidth Plot on Configuration IEEE 802.11b 2462 MHz Port 1

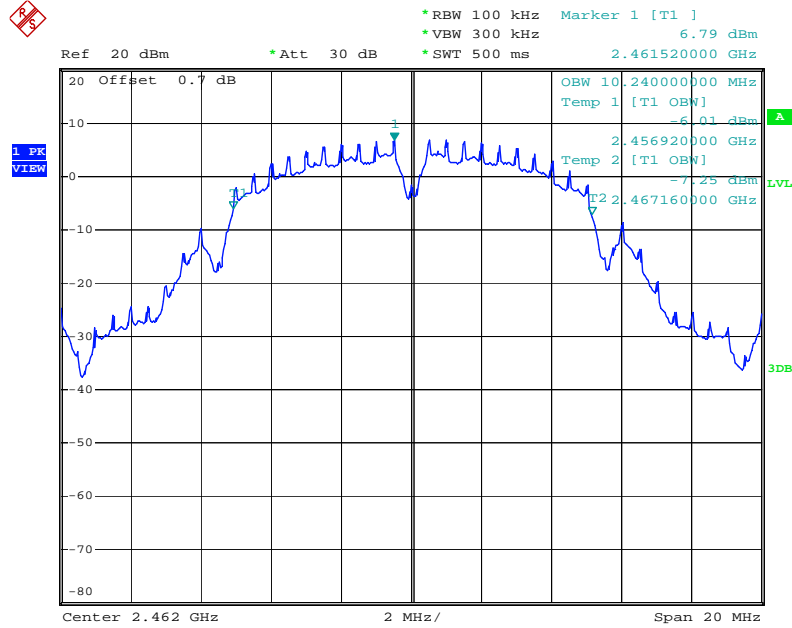

Date: 8.APR.2012 02:16:33

99% Occupied Bandwidth Plot on Configuration IEEE 802.11g 2412 MHz Port 1

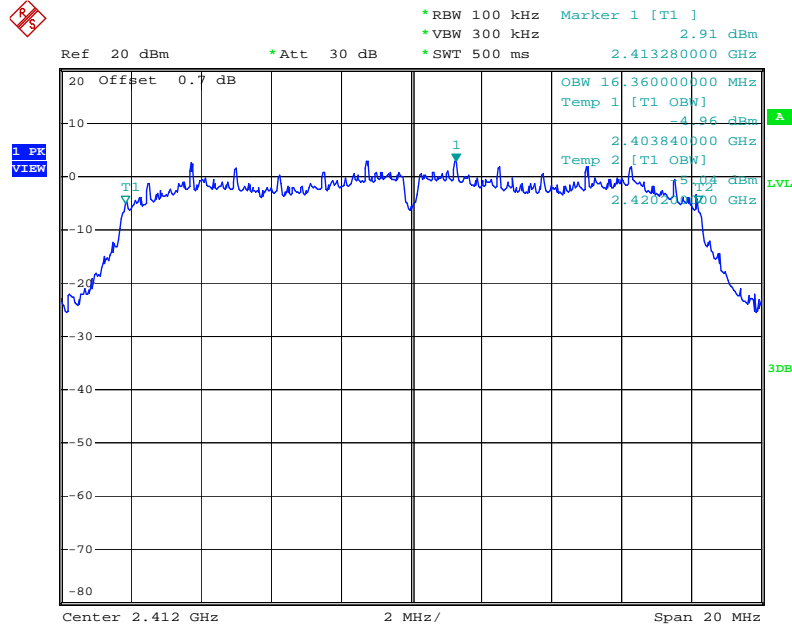

Date: 7.APR.2012 03:14:42

99% Occupied Bandwidth Plot on Configuration IEEE 802.11g 2437 MHz Port 1

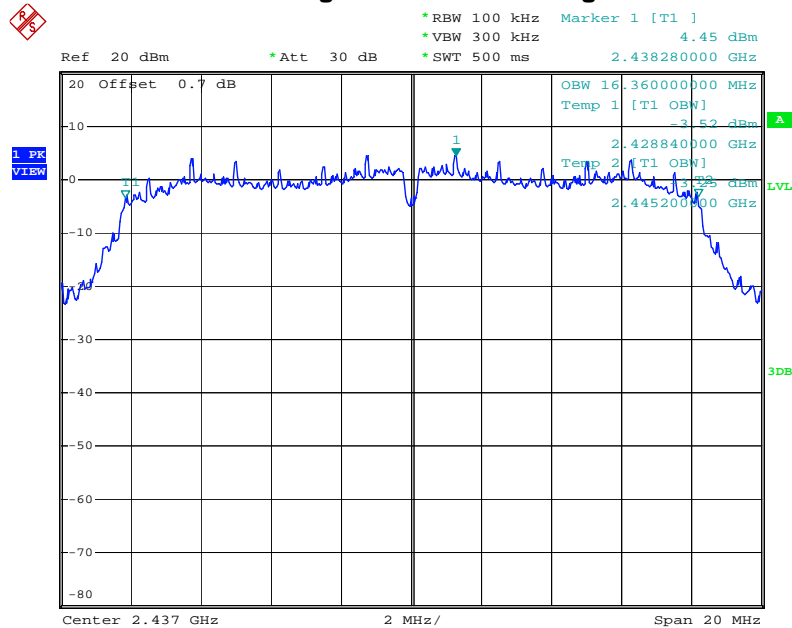

Date: 7.APR.2012 03:19:22

99% Occupied Bandwidth Plot on Configuration IEEE 802.11g 2462 MHz Port 1

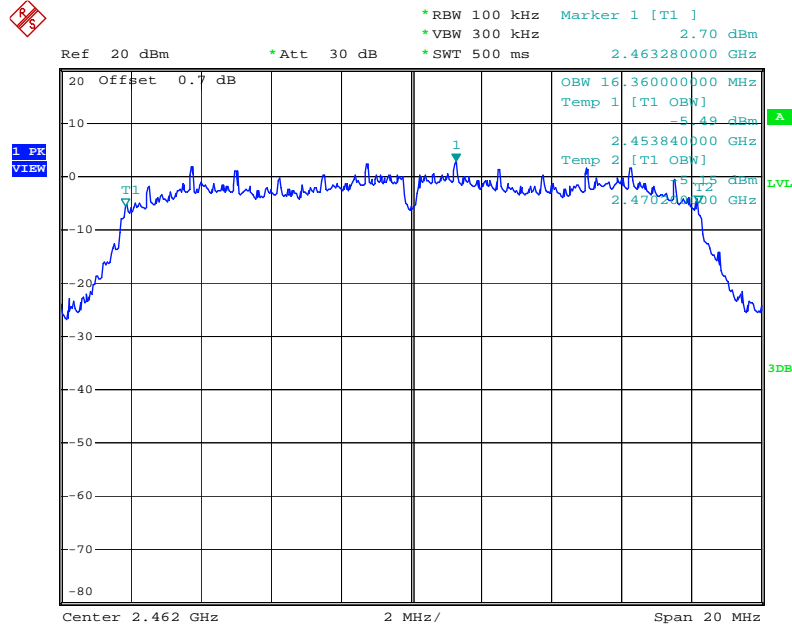

Date: 7.APR.2012 03:22:10

99% Occupied Bandwidth Plot on Configuration IEEE 802.11n (20MHz) 2412 MHz Port 1

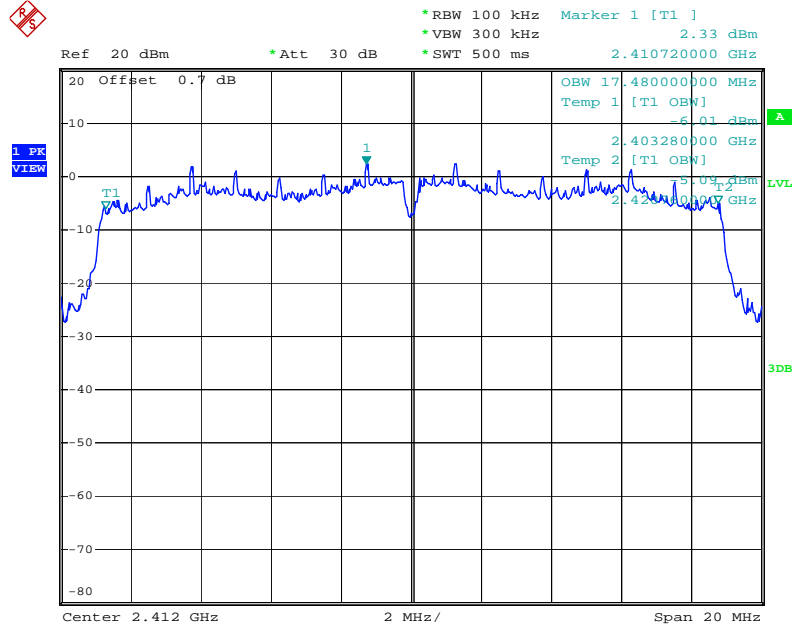

Date: 7.APR.2012 03:28:31

99% Occupied Bandwidth Plot on Configuration IEEE 802.11n (20MHz) 2437 MHz Port 1

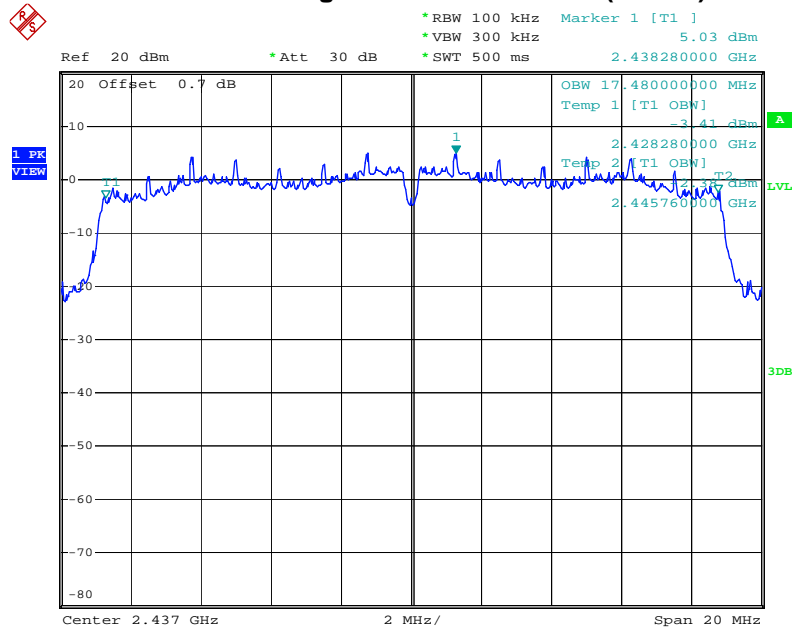

Date: 7.APR.2012 03:32:56

99% Occupied Bandwidth Plot on Configuration IEEE 802.11n (20MHz) 2462 MHz Port 1

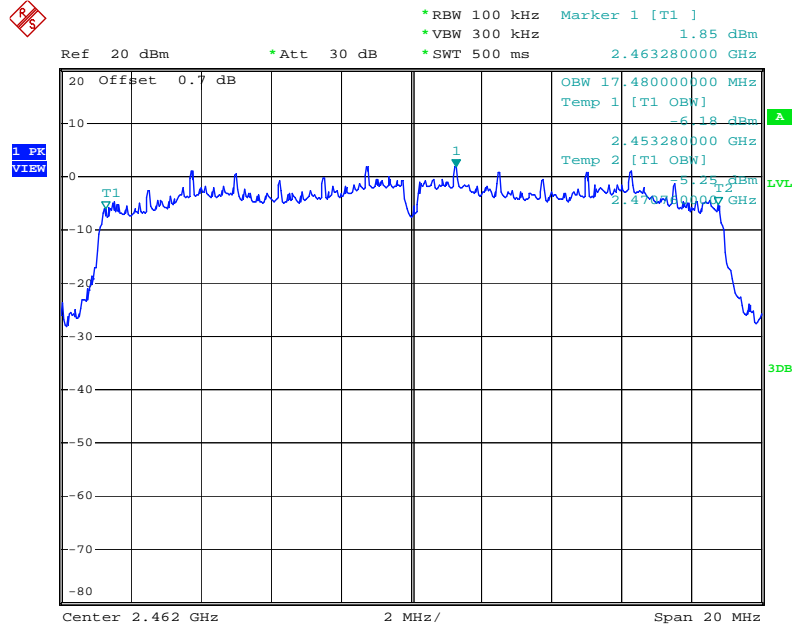

Date: 7.APR.2012 03:36:05

99% Occupied Bandwidth Plot on Configuration IEEE 802.11n (40MHz) 2422 MHz Port 1

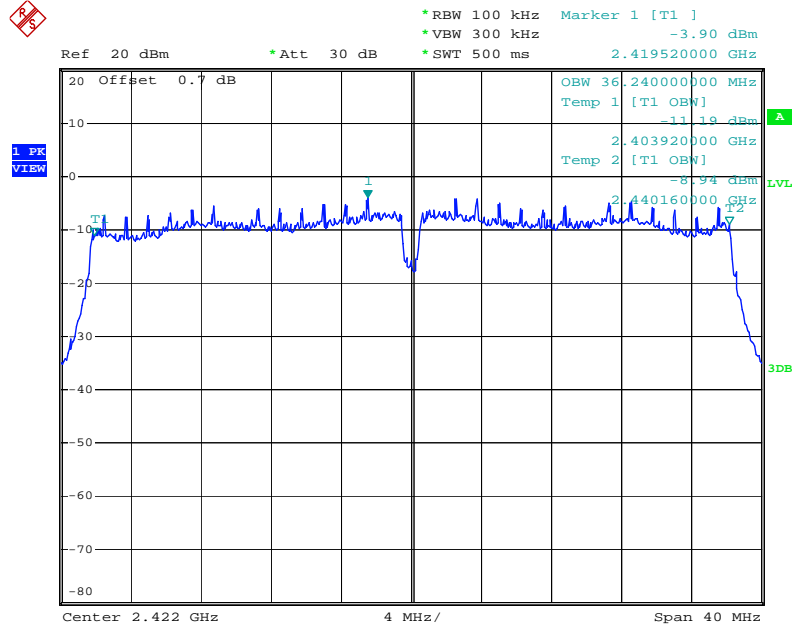

Date: 7.APR.2012 03:45:28

99% Occupied Bandwidth Plot on Configuration IEEE 802.11n (40MHz) 2437 MHz Port 1

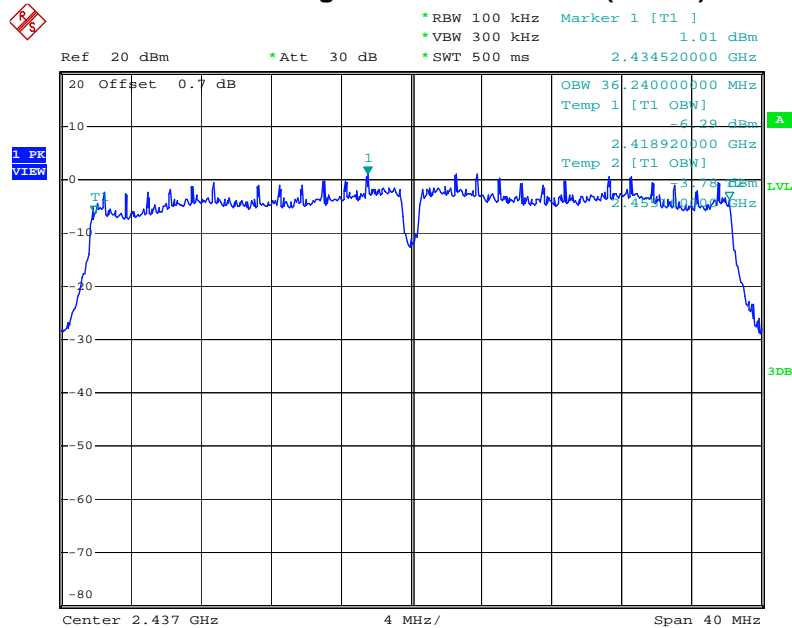

Date: 7.APR.2012 03:53:45

99% Occupied Bandwidth Plot on Configuration IEEE 802.11n (40MHz) 2452 MHz Port 1

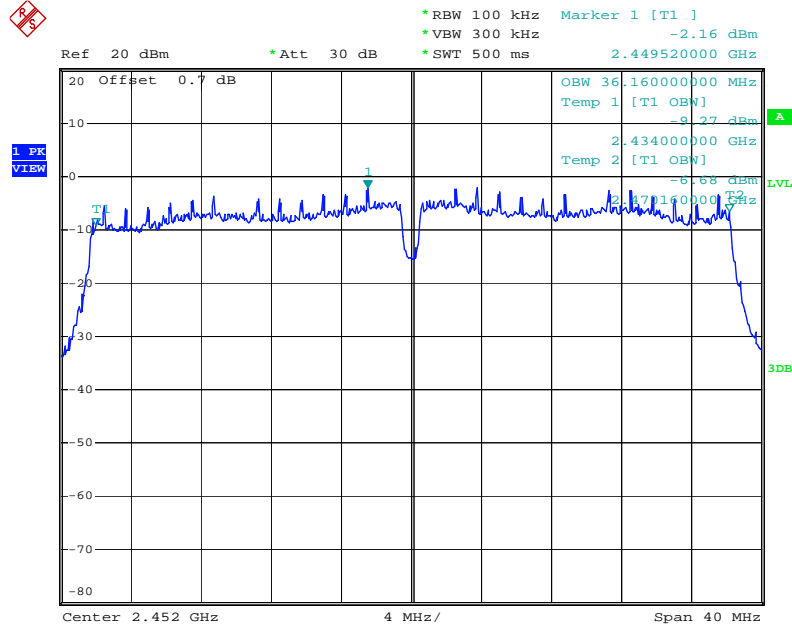

Date: 7.APR.2012 03:55:39

For Two Chains:
 99% Occupied Bandwidth Plot on Configuration IEEE 802.11n (20MHz) 2412 MHz Port 1

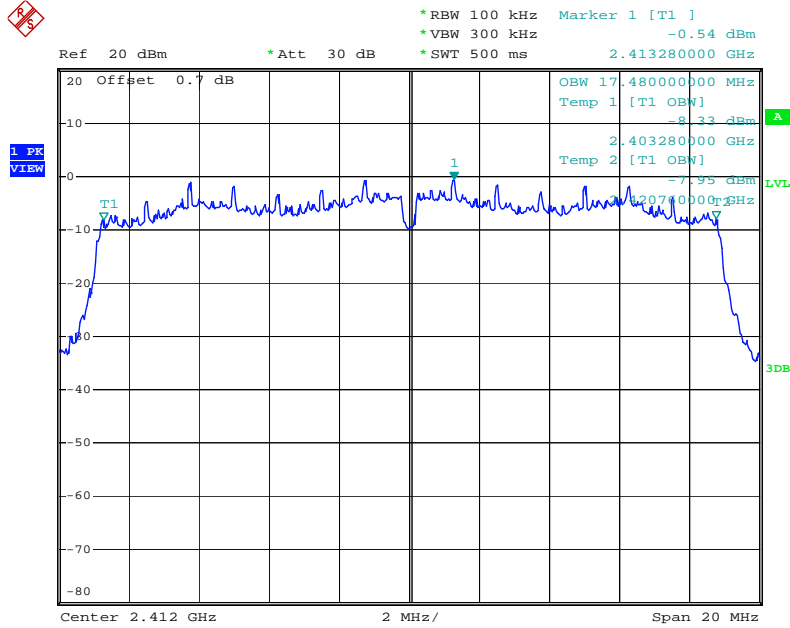

Date: 7.APR.2012 05:04:38

99% Occupied Bandwidth Plot on Configuration IEEE 802.11n (20MHz) 2437 MHz Port 1

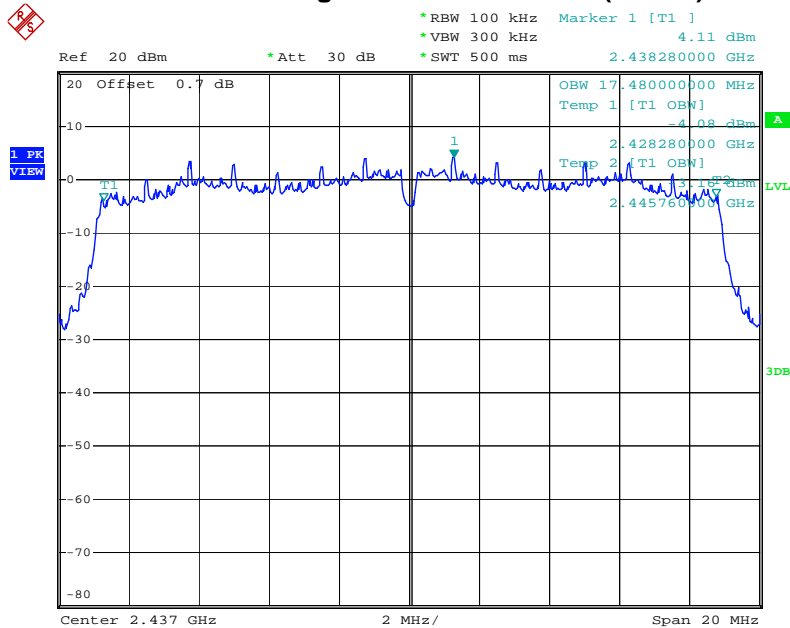

Date: 7.APR.2012 05:08:54

99% Occupied Bandwidth Plot on Configuration IEEE 802.11n (20MHz) 2462 MHz Port 1

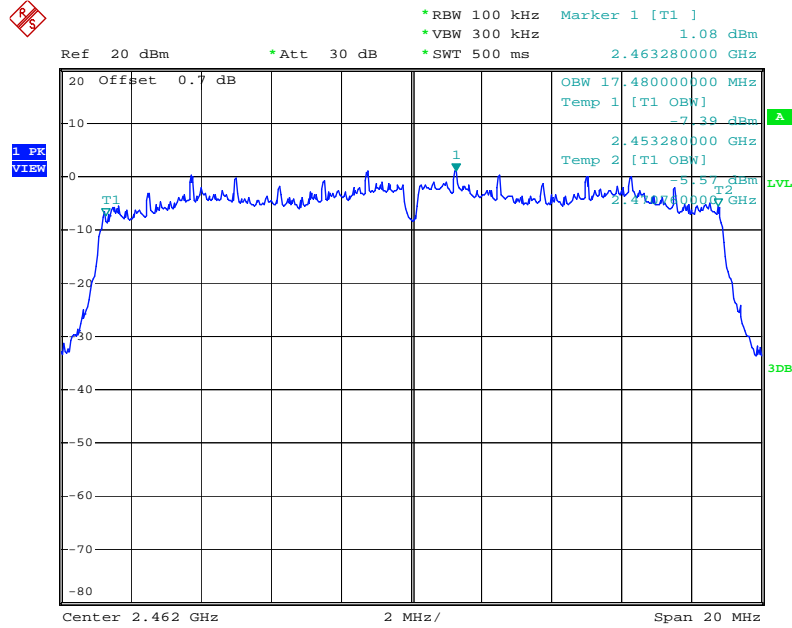

Date: 7.APR.2012 05:13:32

99% Occupied Bandwidth Plot on Configuration IEEE 802.11n (20MHz) 2412 MHz Port 2

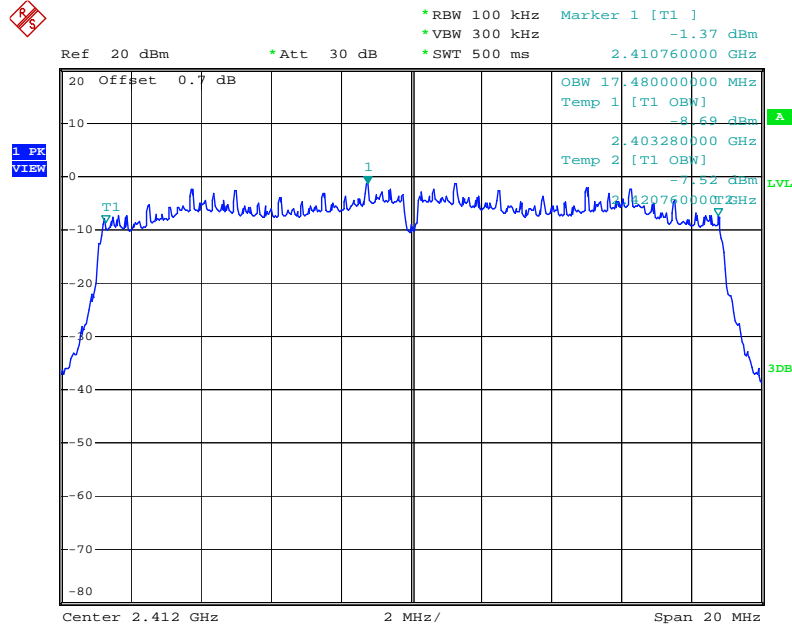

Date: 7.APR.2012 05:20:10

99% Occupied Bandwidth Plot on Configuration IEEE 802.11n (20MHz) 2437 MHz Port 2

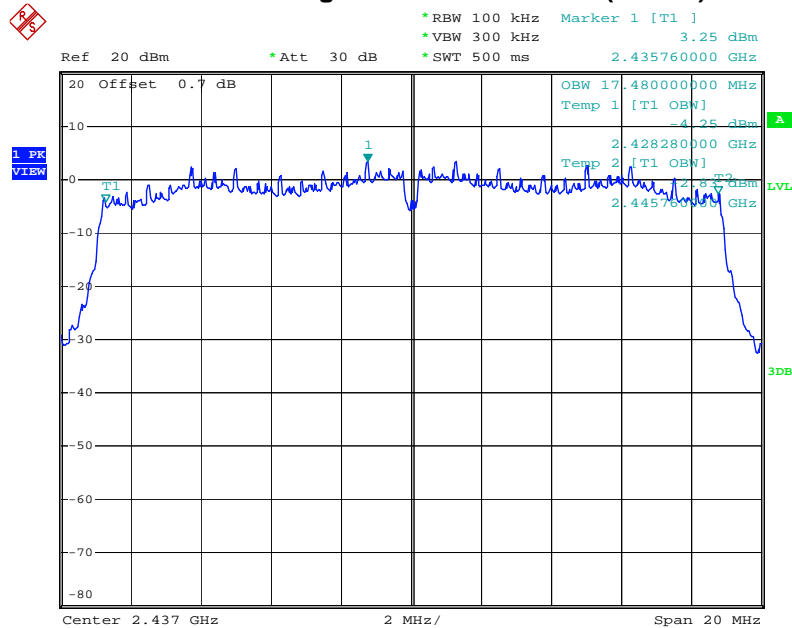

Date: 7.APR.2012 05:27:32

99% Occupied Bandwidth Plot on Configuration IEEE 802.11n (20MHz) 2462 MHz Port 2

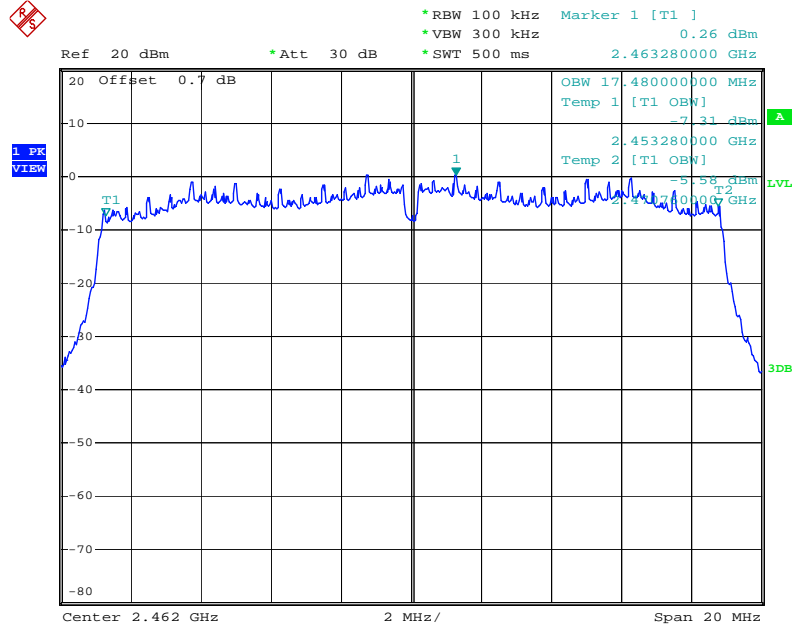

Date: 7.APR.2012 05:31:30

99% Occupied Bandwidth Plot on Configuration IEEE 802.11n (40MHz) 2422 MHz Port 1

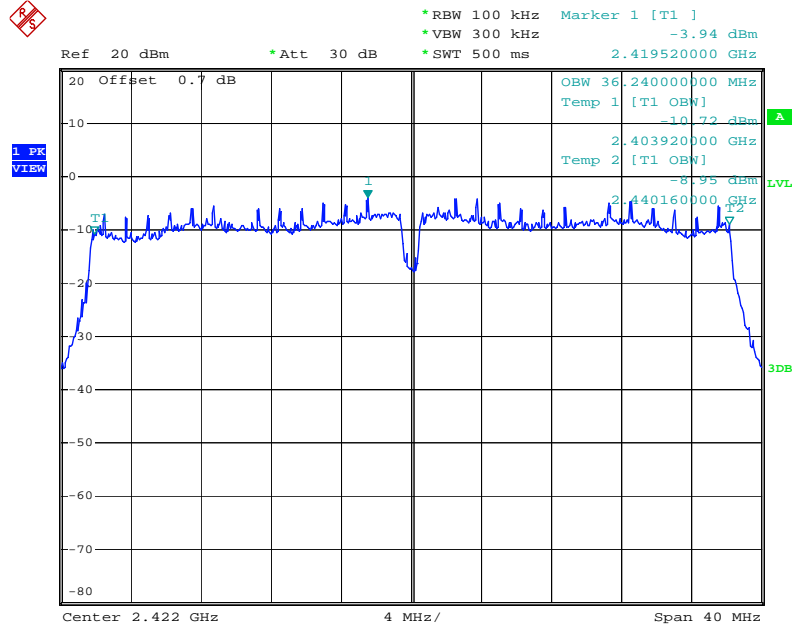

Date: 7.APR.2012 04:15:05

99% Occupied Bandwidth Plot on Configuration IEEE 802.11n (40MHz) 2437 MHz Port 1

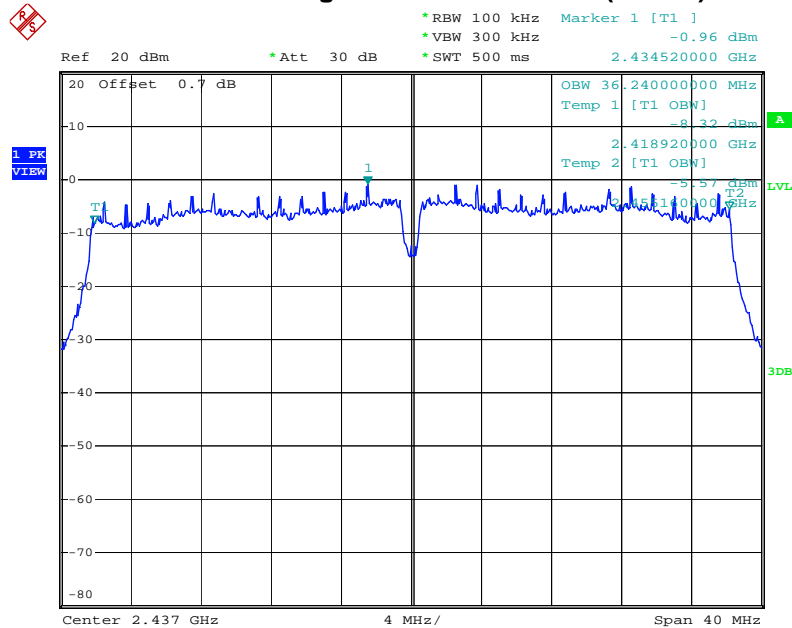

Date: 7.APR.2012 04:22:10

99% Occupied Bandwidth Plot on Configuration IEEE 802.11n (40MHz) 2452 MHz Port 1

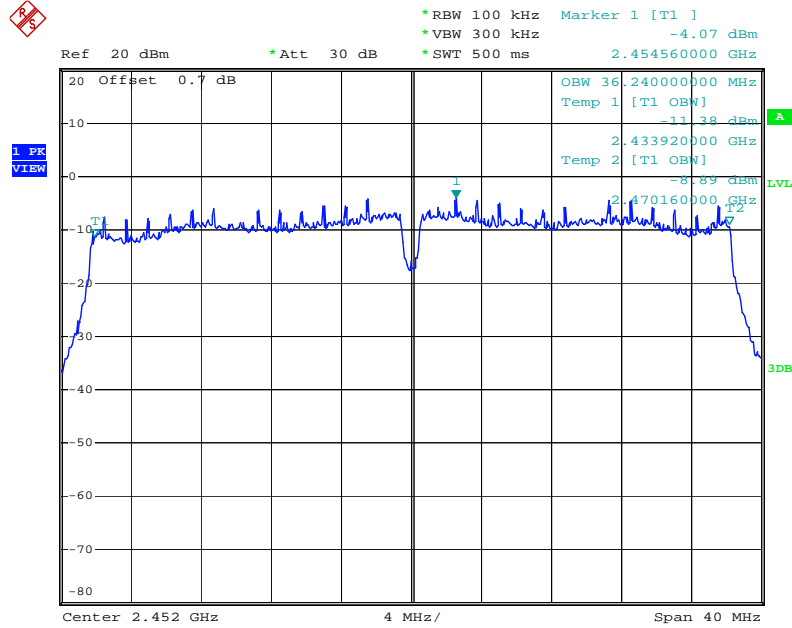

Date: 7.APR.2012 04:26:39

99% Occupied Bandwidth Plot on Configuration IEEE 802.11n (40MHz) 2422 MHz Port 2

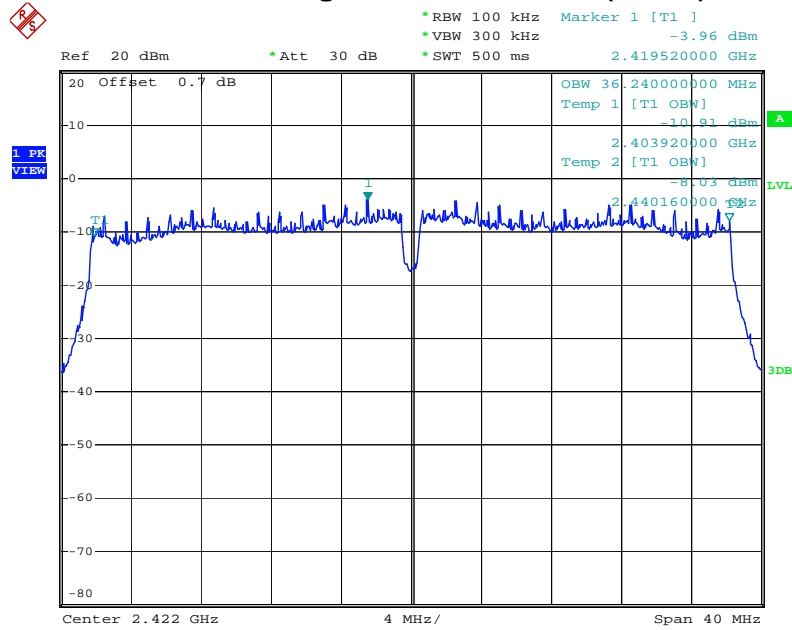

Date: 7.APR.2012 04:33:09

99% Occupied Bandwidth Plot on Configuration IEEE 802.11n (40MHz) 2437 MHz Port 2

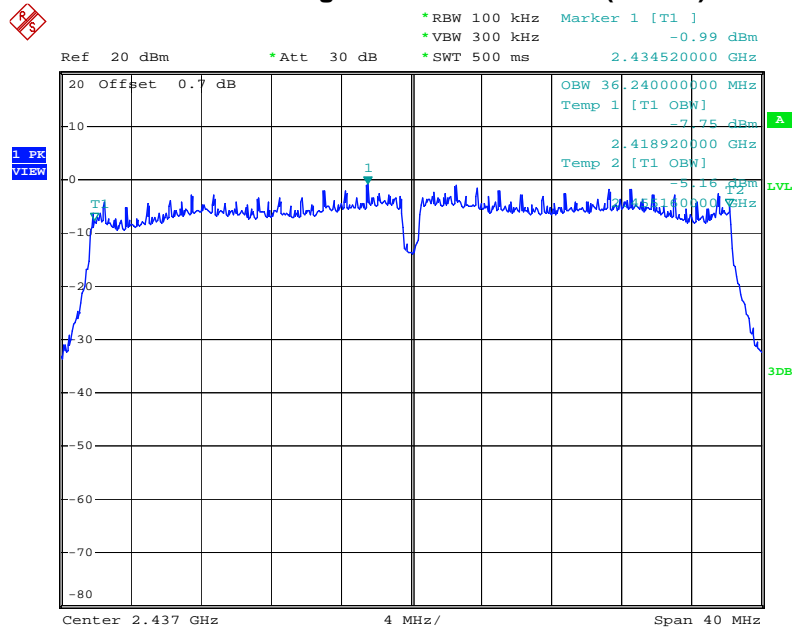

Date: 7.APR.2012 04:38:04

99% Occupied Bandwidth Plot on Configuration IEEE 802.11n (40MHz) 2452 MHz Port 2

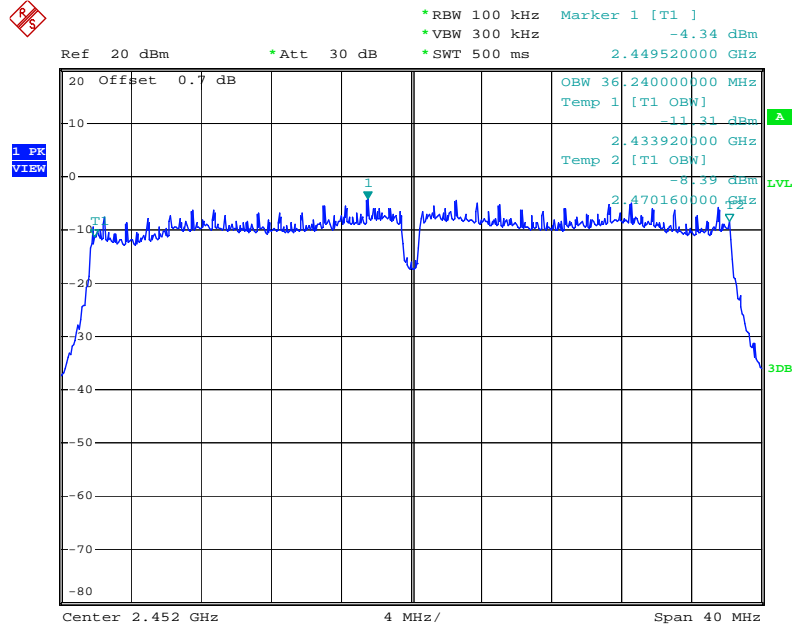

Date: 7.APR.2012 04:42:34

3.5 Radiated Emissions Measurement

3.5.1 Limit

In any 100kHz bandwidth outside the frequency band in which the spread spectrum or digitally modulated intentional radiator is operating, the radio frequency power that is produced by the intentional radiator shall be at least 20dB below that in the 100kHz bandwidth within the band that contains the highest level of the desired power, based on either an RF conducted or a radiated measurement. If the transmitter measurement is based on the maximum conducted output power, the attenuation required under this paragraph shall be 30dB instead of 20dB. In addition, radiated emissions which fall in section 15.205(a) the restricted bands must also comply with the radiated emission limit specified in section 15.209(a).

Frequencies (MHz)	Field Strength (microvolt/meter)	Measurement Distance (meters)
0.009~0.490	2400/F(kHz)	300
0.490~1.705	24000/F(kHz)	30
1.705~30.0	30	30
30~88	100	3
88~216	150	3
216~960	200	3
Above 960	500	3

3.5.2 Measuring Instruments and Setting

Please refer to section 4 of equipments list in this report. The following table is the setting of spectrum analyzer and receiver.

Spectrum Parameter	Setting
Attenuation	Auto
Start Frequency	1000 MHz
Stop Frequency	10th carrier harmonic
RB / VB (Emission in restricted band)	1MHz / 1MHz for Peak, 1 MHz / 10Hz for Average
RB / VB (Emission in non-restricted band)	1MHz / 1MHz for peak

Receiver Parameter	Setting
Attenuation	Auto
Start ~ Stop Frequency	9kHz~150kHz / RB 200Hz for QP
Start ~ Stop Frequency	150kHz~30MHz / RB 9kHz for QP
Start ~ Stop Frequency	30MHz~1000MHz / RB 120kHz for QP

3.5.3 Test Procedures

1. Configure the EUT according to ANSI C63.4. The EUT was placed on the top of the turntable 0.8 meter above ground. The phase center of the receiving antenna mounted on the top of a height-variable antenna tower was placed 3 meters far away from the turntable.
2. Power on the EUT and all the supporting units. The turntable was rotated by 360 degrees to determine the position of the highest radiation.
3. The height of the broadband receiving antenna was varied between one meter and four meters above ground to find the maximum emissions field strength of both horizontal and vertical polarization.
4. For each suspected emissions, the antenna tower was scan (from 1 M to 4 M) and then the turntable was rotated (from 0 degree to 360 degrees) to find the maximum reading.
5. Set the test-receiver system to Peak or CISPR quasi-peak Detect Function with specified bandwidth under Maximum Hold Mode.
6. For emissions above 1GHz, use 1MHz VBW and RBW for peak reading. Then 1MHz RBW and 10Hz VBW for average reading in spectrum analyzer.
7. When the radiated emissions limits are expressed in terms of the average value of the emissions, and pulsed operation is employed, the measurement field strength shall be determined by averaging over one complete pulse train, including blanking intervals, as long as the pulse train does not exceed 0.1 seconds. As an alternative (provided the transmitter operates for longer than 0.1 seconds) or in cases where the pulse train exceeds 0.1 seconds, the measured field strength shall be determined from the average absolute voltage during a 0.1 second interval during which the field strength is at its maximum value.
8. If the emissions level of the EUT in peak mode was 3 dB lower than the average limit specified, then testing will be stopped and peak values of EUT will be reported, otherwise, the emissions which do not have 3 dB margin will be repeated one by one using the quasi-peak method for below 1GHz.
9. For testing above 1GHz, the emissions level of the EUT in peak mode was lower than average limit (that means the emissions level in peak mode also complies with the limit in average mode), then testing will be stopped and peak values of EUT will be reported, otherwise, the emissions will be measured in average mode again and reported.
10. In case the emission is lower than 30MHz, loop antenna has to be used for measurement and the recorded data should be QP measured by receiver. High – Low scan is not required in this case.

3.5.4 Test Setup Layout

For radiated emissions below 30MHz

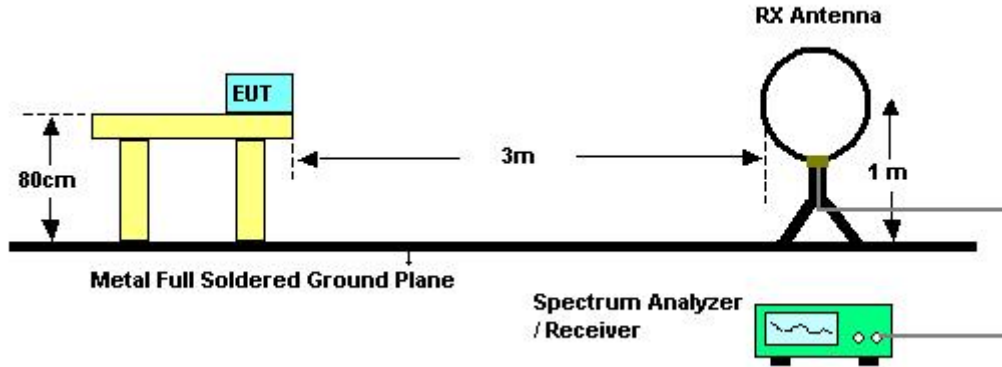

For radiated emissions above 30MHz

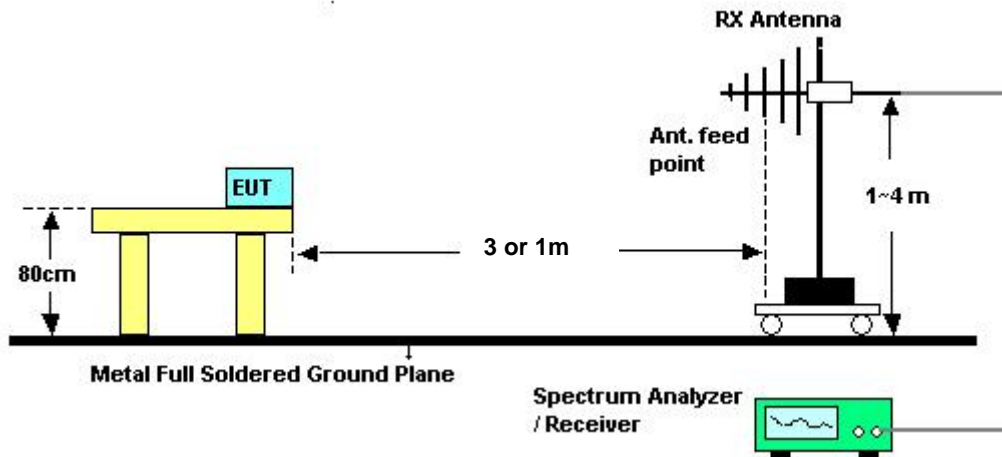

Above 10 GHz shall be extrapolated to the specified distance using an extrapolation factor of 20 dB/decade from 3m to 1m.

Distance extrapolation factor = $20 \log (\text{specific distance [3m]} / \text{test distance [1m]})$ (dB);

Limit line = specific limits (dBuV) + distance extrapolation factor [9.54 dB].

3.5.5 Test Deviation

There is no deviation with the original standard.

3.5.6 EUT Operation during Test

The EUT was programmed to be in continuously transmitting mode.

3.5.7 Results of Radiated Emissions (9kHz~30MHz)

Final Test Date	Apr. 04, 2011	Test Site No.	03CH02-HY
Temperature	24.9°C	Humidity	53%
Test Engineer	Streak		

Freq. (MHz)	Level (dBuV)	Over Limit (dB)	Limit Line (dBuV)	Remark
-	-	-	-	See Note

Note:

The amplitude of spurious emissions that are attenuated by more than 20 dB below the permissible value has no need to be reported.

Distance extrapolation factor = 40 log (specific distance / test distance) (dB);

Limit line = specific limits (dBuV) + distance extrapolation factor.

3.5.8 Results of Radiated Emissions (30MHz~1GHz)

For Single Chain:

Final Test Date	Apr. 04, 2011	Test Site No.	03CH02-HY
Temperature	24.9°C	Humidity	53%
Test Engineer	Streak	Configuration	802.11g Ch. 6

Horizontal

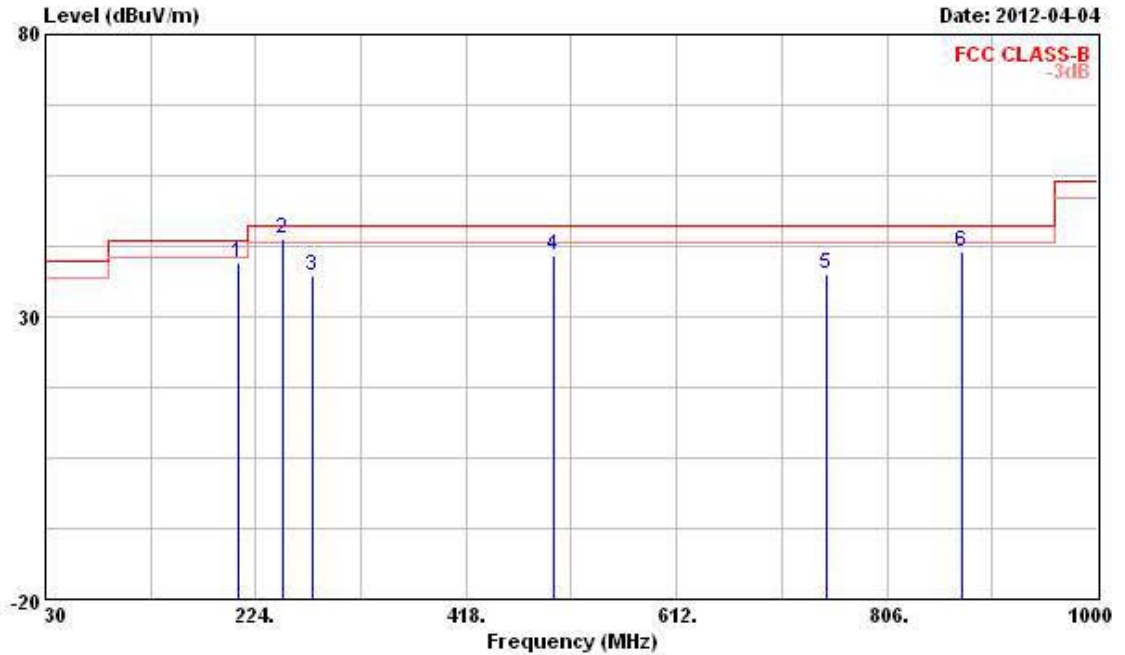

	Freq	Level	Over Limit	Limit Line	ReadAntenna Level	Antenna Factor	Cable Loss	Preamp Factor	Remark	Ant Pos	Table Pos
	MHz	dBuV/m	dB	dBuV/m	dBuV	dB/m	dB	dB		cm	deg
1	207.510	39.63	-3.87	43.50	52.94	11.60	2.48	27.39	Peak	---	---
2	249.220	43.90	-2.10	46.00	55.45	12.97	2.77	27.29	QP	---	---
3	276.380	37.30	-8.70	46.00	48.28	13.37	2.87	27.22	Peak	---	---
4	498.510	41.00	-5.00	46.00	48.28	17.26	3.82	28.36	Peak	---	---
5	749.740	37.46	-8.54	46.00	41.31	19.55	4.71	28.11	Peak	---	---
6	874.870	41.50	-4.50	46.00	43.95	20.09	5.15	27.69	Peak	---	---

Vertical

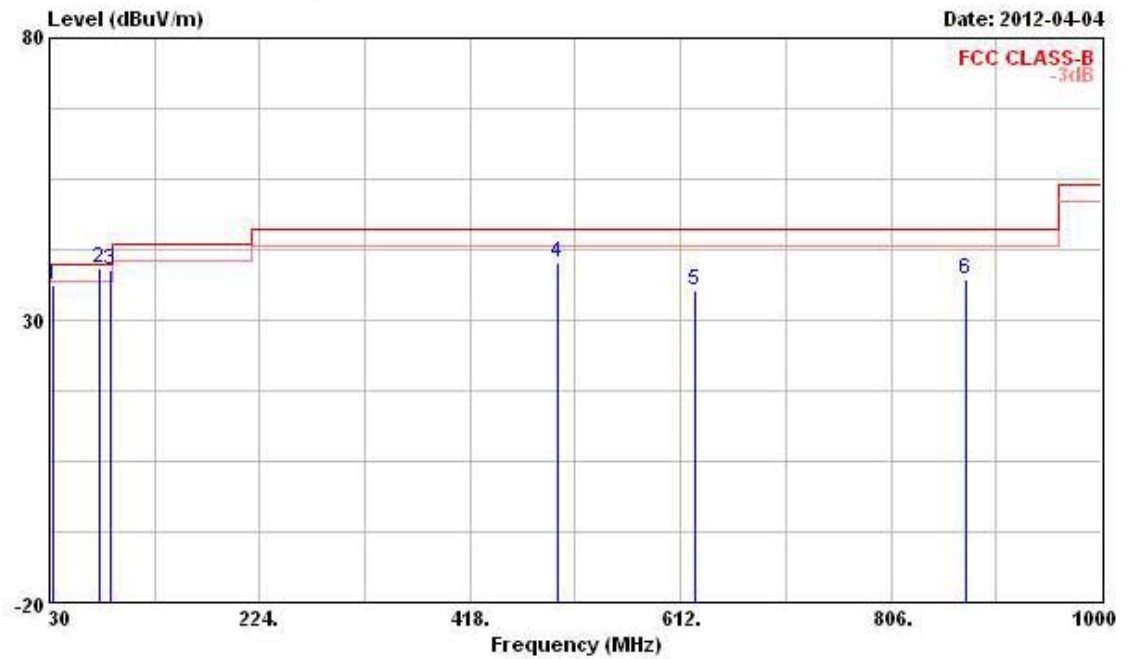

	Freq	Level	Over Limit	Limit Line	ReadAntenna Level	Antenna Factor	Cable Loss	Preamp Factor	Remark	Ant Pos	Table Pos
	MHz	dBuV/m	dB	dBuV/m	dBuV	dB/m	dB	dB		cm	deg
1	32.910	36.10	-3.90	40.00	48.00	15.11	0.93	27.94	QP	---	---
2	75.590	39.19	-0.81	40.00	58.46	7.11	1.47	27.85	QP	---	---
3	87.230	38.89	-1.11	40.00	56.25	8.92	1.57	27.85	QP	---	---
4	498.510	40.13	-5.87	46.00	47.41	17.26	3.82	28.36	Peak	---	---
5	625.580	35.11	-10.89	46.00	39.36	19.84	4.32	28.41	Peak	---	---
6	874.870	37.22	-8.78	46.00	39.67	20.09	5.15	27.69	Peak	---	---

Note:

The amplitude of spurious emissions that are attenuated by more than 20dB below the permissible value has no need to be reported.

Emission level (dBuV/m) = 20 log Emission level (uV/m).

Corrected Reading: Antenna Factor + Cable Loss + Read Level - Preamp Factor = Level.

Final Test Date	Apr. 04, 2011	Test Site No.	03CH02-HY
Temperature	24.9°C	Humidity	53%
Test Engineer	Streak	Configuration	802.11n (20MHz) Ch. 6

Horizontal

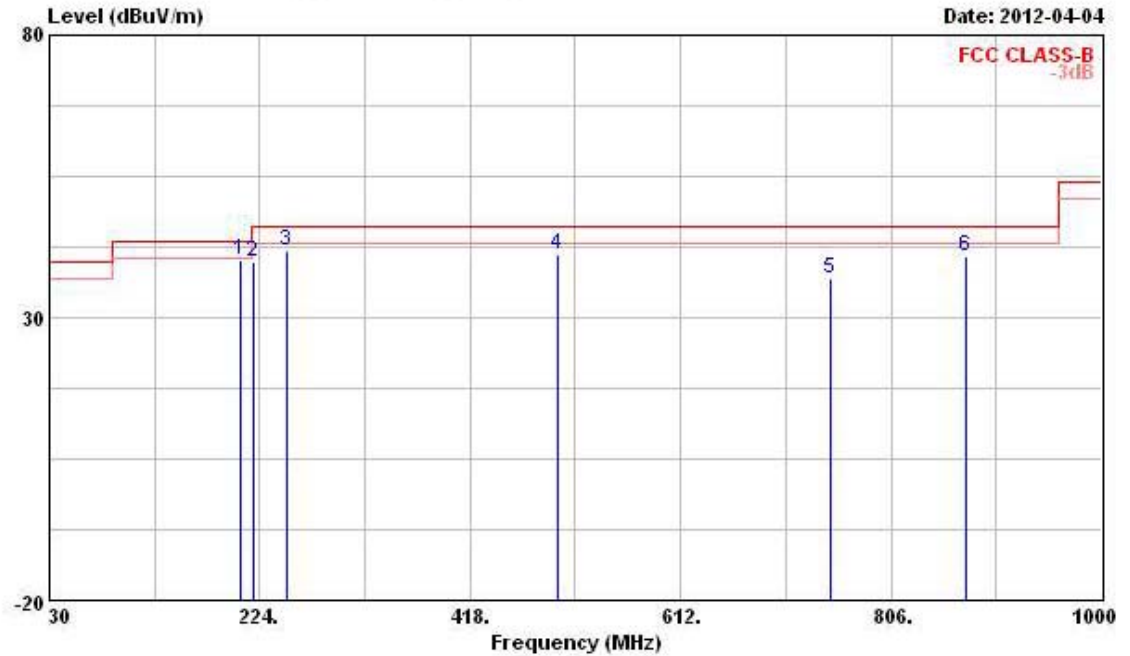

	Freq	Level	Over Limit	Limit Line	ReadAntenna Level	Antenna Factor	Cable Loss	Preamp Factor	Remark	Ant Pos	Table Pos
	MHz	dBuV/m	dB	dBuV/m	dBuV	dB/m	dB	dB		cm	deg
1	206.540	40.12	-3.38	43.50	53.47	11.57	2.47	27.39	Peak	---	---
2	218.180	39.93	-6.07	46.00	52.80	11.95	2.55	27.37	Peak	---	---
3	249.220	41.78	-4.22	46.00	53.33	12.97	2.77	27.29	Peak	---	---
4	498.510	41.03	-4.97	46.00	48.31	17.26	3.82	28.36	Peak	---	---
5	749.740	36.90	-9.10	46.00	40.75	19.55	4.71	28.11	Peak	---	---
6	874.870	40.88	-5.12	46.00	43.33	20.09	5.15	27.69	Peak	---	---

Vertical

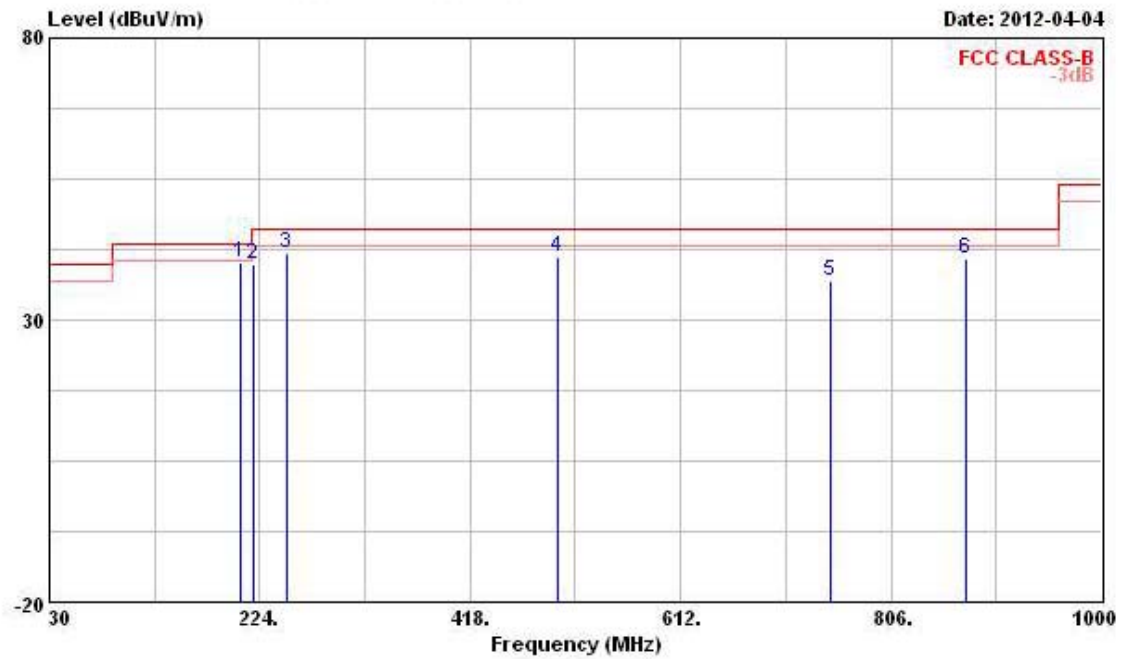

	Freq	Level	Over Limit	Limit Line	ReadAntenna Level	Antenna Factor	Cable Loss	Preamp Factor	Remark	Rnt Pos	Table Pos
	MHz	dBuV/m	dB	dBuV/m	dBuV	dB/m	dB	dB		cm	deg
1	206.540	40.12	-3.38	43.50	53.47	11.57	2.47	27.39	Peak	---	---
2	218.180	39.93	-6.07	46.00	52.80	11.95	2.55	27.37	Peak	---	---
3	249.220	41.78	-4.22	46.00	53.33	12.97	2.77	27.29	Peak	---	---
4	498.510	41.03	-4.97	46.00	48.31	17.26	3.82	28.36	Peak	---	---
5	749.740	36.90	-9.10	46.00	40.75	19.55	4.71	28.11	Peak	---	---
6	874.870	40.88	-5.12	46.00	43.33	20.09	5.15	27.69	Peak	---	---

Note:

The amplitude of spurious emissions that are attenuated by more than 20dB below the permissible value has no need to be reported.

Emission level (dBuV/m) = 20 log Emission level (uV/m).

Corrected Reading: Antenna Factor + Cable Loss + Read Level - Preamp Factor = Level.

Final Test Date	Apr. 04, 2011	Test Site No.	03CH02-HY
Temperature	24.9°C	Humidity	53%
Test Engineer	Streak	Configuration	802.11n (40MHz) Ch. 6

Horizontal

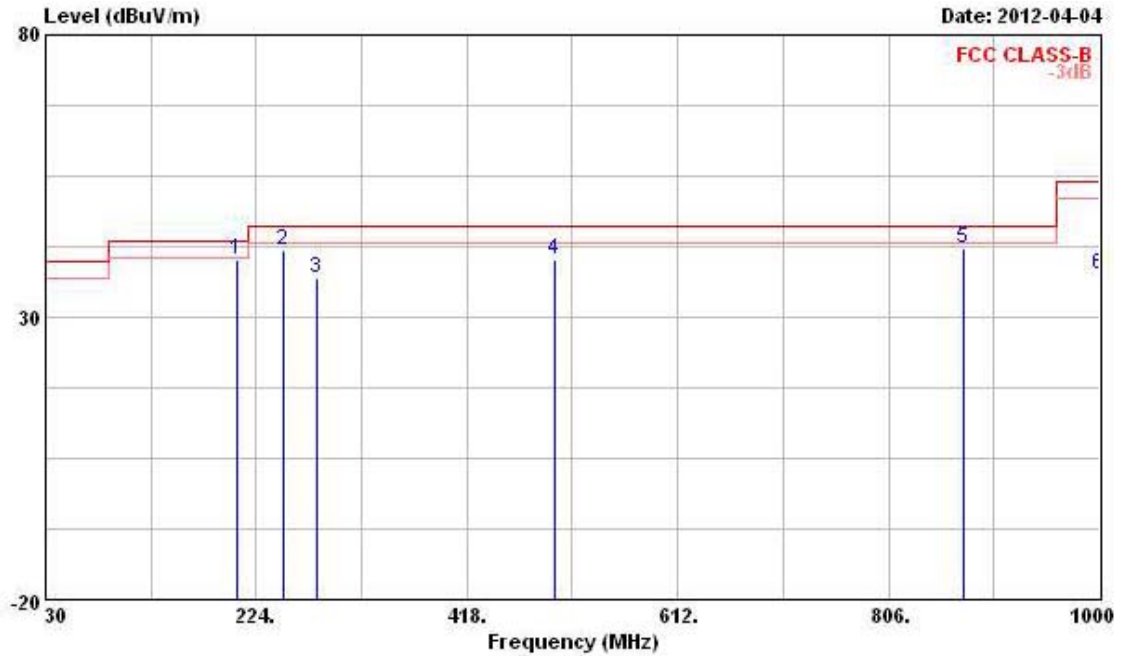

	Freq	Level	Over Limit	Limit Line	Read Level	Antenna Factor	Cable Loss	Preamp	Remark	Ant Pos	Table Pos
	MHz	dBuV/m	dB	dBuV/m	dBuV	dB/m	dB	dB		cm	deg
1	206.540	40.32	-3.18	43.50	53.67	11.57	2.47	27.39	Peak	---	---
2	249.220	41.98	-4.02	46.00	53.53	12.97	2.77	27.29	Peak	---	---
3	280.260	37.01	-8.99	46.00	47.90	13.43	2.89	27.21	Peak	---	---
4	498.510	40.21	-5.79	46.00	47.49	17.26	3.82	28.36	Peak	---	---
5	874.870	42.24	-3.76	46.00	44.69	20.09	5.15	27.69	Peak	---	---
6	999.900	37.51	-16.49	54.00	36.57	22.50	5.67	27.23	Peak	---	---

Vertical

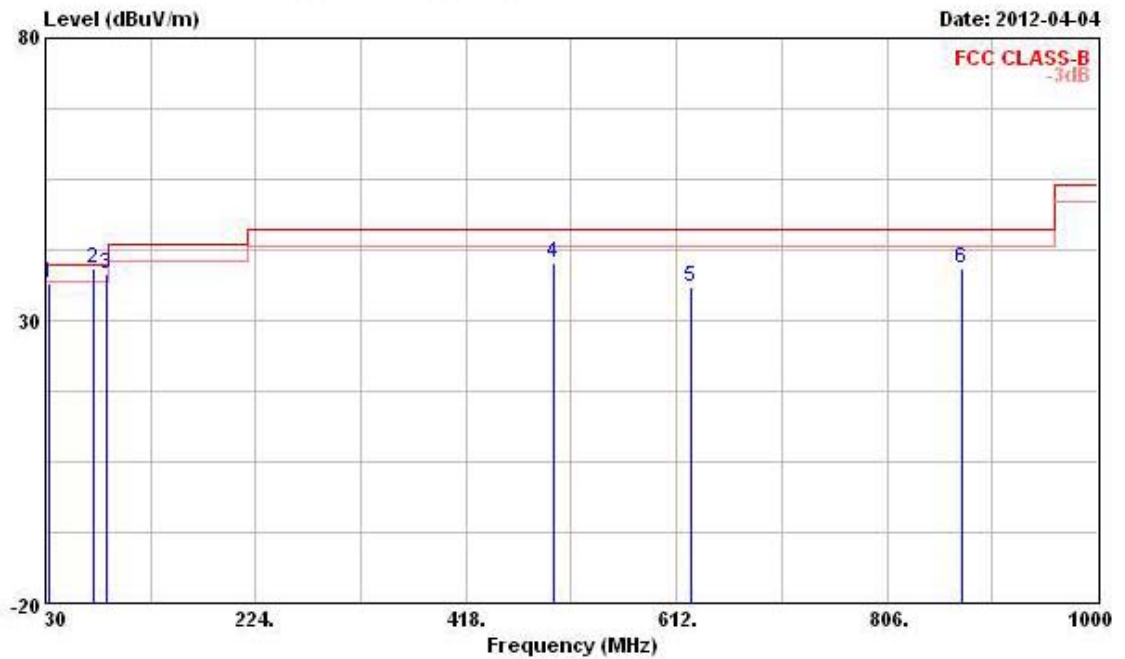

	Freq	Level	Over Limit	Limit Line	ReadAntenna Level	Antenna Factor	Cable Loss	Preamp Factor	Remark	Ant Pos	Table Pos
	MHz	dBuV/m	dB	dBuV/m	dBuV	dB/m	dB	dB		cm	deg
1	32.910	36.44	-3.56	40.00	48.34	15.11	0.93	27.94	QP	---	---
2	74.620	39.22	-0.78	40.00	58.56	7.05	1.46	27.85	QP	---	---
3	86.260	38.33	-1.67	40.00	55.89	8.73	1.56	27.85	QP	---	---
4	498.510	40.26	-5.74	46.00	47.54	17.26	3.82	28.36	Peak	---	---
5	625.580	35.91	-10.09	46.00	40.16	19.84	4.32	28.41	Peak	---	---
6	874.870	39.13	-6.87	46.00	41.58	20.09	5.15	27.69	Peak	---	---

Note:

The amplitude of spurious emissions that are attenuated by more than 20dB below the permissible value has no need to be reported.

Emission level (dBuV/m) = 20 log Emission level (uV/m).

Corrected Reading: Antenna Factor + Cable Loss + Read Level - Preamp Factor = Level.

For Two Chains:

Final Test Date	Apr. 04, 2011	Test Site No.	03CH02-HY
Temperature	24.9°C	Humidity	53%
Test Engineer	Streak	Configuration	802.11n (20MHz) Ch. 6

Horizontal

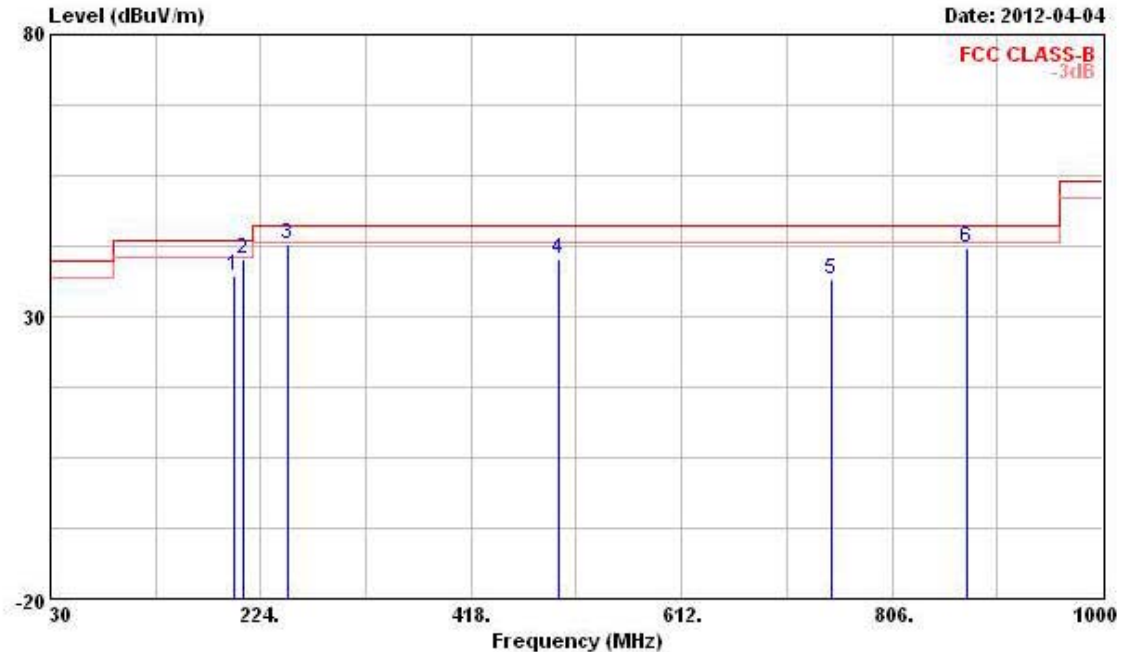

	Freq	Level	Over Limit	Limit Line	ReadAntenna Level	Antenna Factor	Cable Loss	Preamp Factor	Remark	Ant Pos	Table Pos
	MHz	dBuV/m	dB	dBuV/m	dBuV	dB/m	dB	dB		cm	deg
1	198.780	37.18	-6.32	43.50	50.90	11.28	2.42	27.42	Peak	---	---
2	207.510	40.08	-3.42	43.50	53.39	11.60	2.48	27.39	Peak	---	---
3	249.220	42.99	-3.01	46.00	54.54	12.97	2.77	27.29	Peak	---	---
4	498.510	40.26	-5.74	46.00	47.54	17.26	3.82	28.36	Peak	---	---
5	749.740	36.53	-9.47	46.00	40.38	19.55	4.71	28.11	Peak	---	---
6	874.870	42.32	-3.68	46.00	44.77	20.09	5.15	27.69	Peak	---	---

Vertical

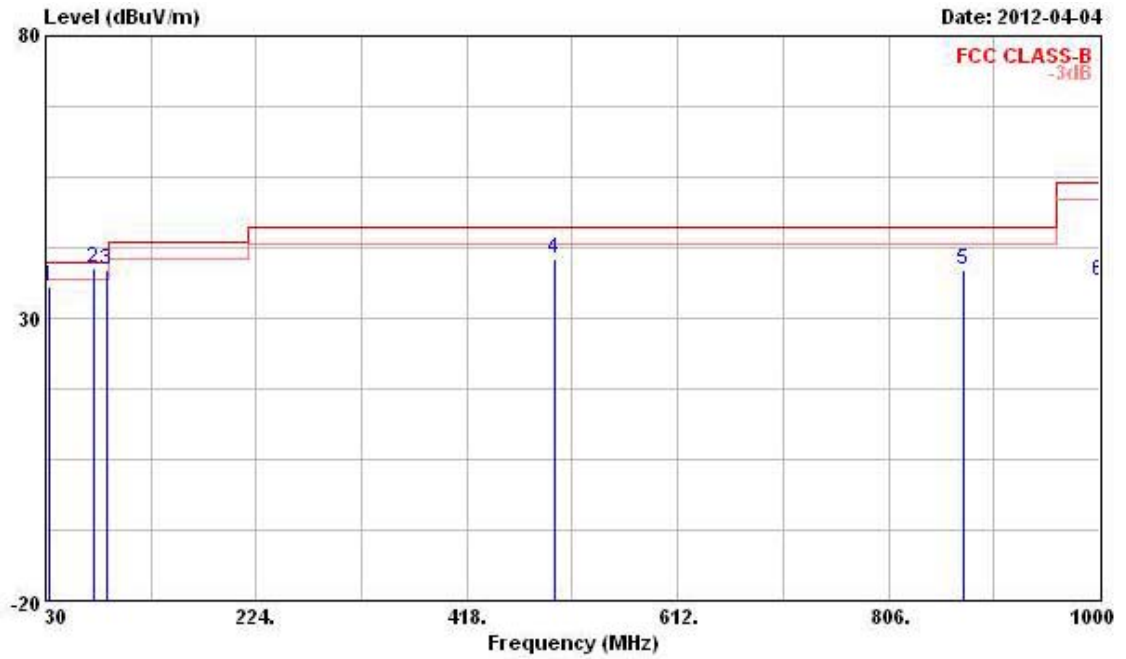

	Freq	Level	Over Limit	Limit Line	Read Level	Antenna Factor	Cable Loss	Preamp Factor	Remark	Ant Pos	Table Pos
	MHz	dBuV/m	dB	dBuV/m	dBuV	dB/m	dB	dB		cm	deg
1	32.910	35.71	-4.29	40.00	47.61	15.11	0.93	27.94	QP	---	---
2	74.620	38.75	-1.25	40.00	58.09	7.05	1.46	27.85	QP	---	---
3	86.260	38.46	-1.54	40.00	56.02	8.73	1.56	27.85	QP	---	---
4	498.510	40.50	-5.50	46.00	47.78	17.26	3.82	28.36	Peak	---	---
5	874.870	38.69	-7.31	46.00	41.14	20.09	5.15	27.69	Peak	---	---
6	999.900	36.49	-17.51	54.00	35.55	22.50	5.67	27.23	Peak	---	---

Note:
 The amplitude of spurious emissions that are attenuated by more than 20dB below the permissible value has no need to be reported.
 Emission level (dBuV/m) = 20 log Emission level (uV/m).
 Corrected Reading: Antenna Factor + Cable Loss + Read Level - Preamp Factor = Level.

Final Test Date	Apr. 04, 2011	Test Site No.	03CH02-HY
Temperature	24.9°C	Humidity	53%
Test Engineer	Streak	Configuration	802.11n (40MHz) Ch. 6

Horizontal

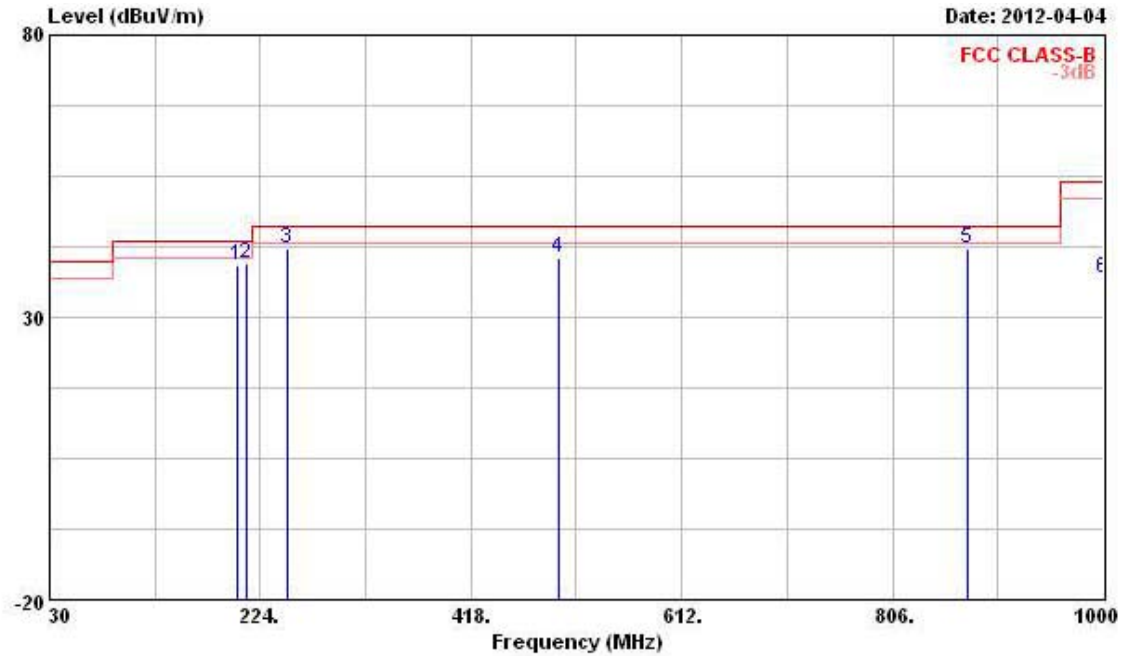

	Freq	Level	Over Limit	Limit Line	ReadAntenna Level	Antenna Factor	Cable Loss	Preamp Factor	Remark	Ant Pos	Table Pos
	MHz	dBuV/m	dB	dBuV/m	dBuV	dB/m	dB	dB		cm	deg
1	202.660	39.08	-4.42	43.50	52.59	11.45	2.44	27.40	Peak	---	---
2	211.390	39.70	-3.80	43.50	52.84	11.73	2.51	27.38	Peak	---	---
3	249.220	42.15	-3.85	46.00	53.70	12.97	2.77	27.29	Peak	---	---
4	498.510	40.60	-5.40	46.00	47.88	17.26	3.82	28.36	Peak	---	---
5	874.870	42.20	-3.80	46.00	44.65	20.09	5.15	27.69	Peak	---	---
6	999.900	36.94	-17.06	54.00	36.00	22.50	5.67	27.23	Peak	---	---

Vertical

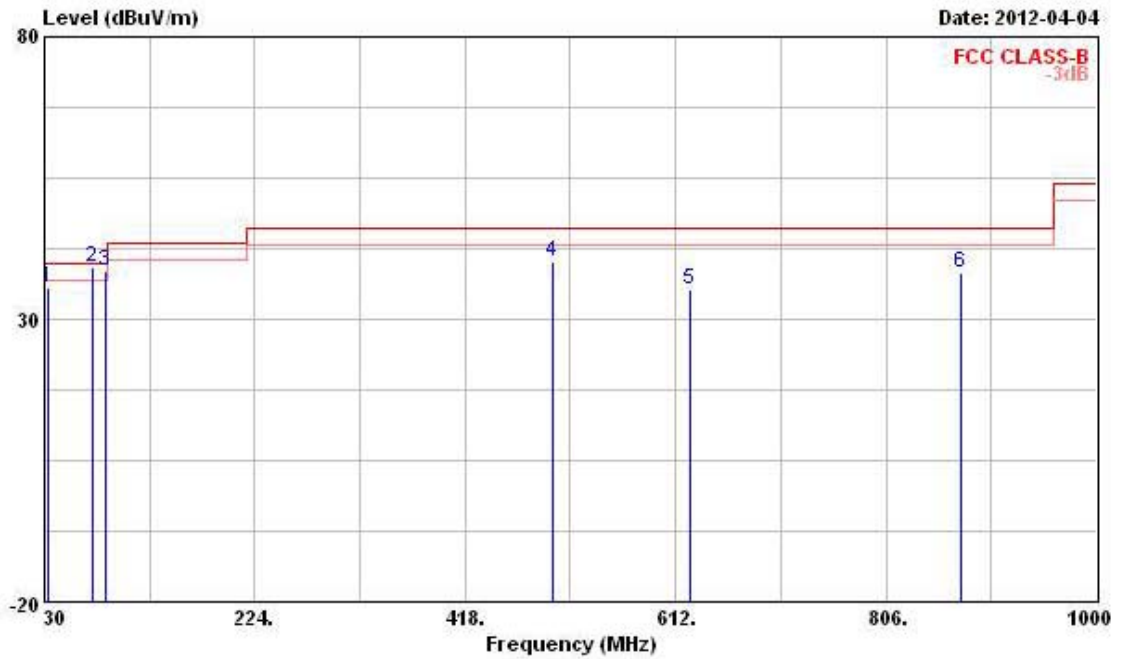

	Freq	Level	Over Limit	Limit Line	ReadAntenna Level	Antenna Factor	Cable Loss	Preamp Factor	Remark	Ant Pos	Table Pos
	MHz	dBuV/m	dB	dBuV/m	dBuV	dB/m	dB	dB		cm	deg
1	32.910	35.53	-4.47	40.00	47.43	15.11	0.93	27.94	QP	---	---
2	74.620	39.27	-0.73	40.00	58.61	7.05	1.46	27.85	QP	---	---
3	86.260	38.52	-1.48	40.00	56.08	8.73	1.56	27.85	QP	---	---
4	498.510	40.27	-5.73	46.00	47.55	17.26	3.82	28.36	Peak	---	---
5	625.580	35.29	-10.71	46.00	39.54	19.84	4.32	28.41	Peak	---	---
6	874.870	38.20	-7.80	46.00	40.65	20.09	5.15	27.69	Peak	---	---

Note:

The amplitude of spurious emissions that are attenuated by more than 20dB below the permissible value has no need to be reported.

Emission level (dBuV/m) = 20 log Emission level (uV/m).

Corrected Reading: Antenna Factor + Cable Loss + Read Level - Preamp Factor = Level.

3.5.9 Results for Radiated Emissions (1GHz~10th Harmonic)

For Single Chain:

Final Test Date	Mar. 23, 2011	Test Site No.	03CH02-HY
Temperature	24.9°C	Humidity	53%
Test Engineer	Streak	Configuration	802.11b Ch. 1

Horizontal

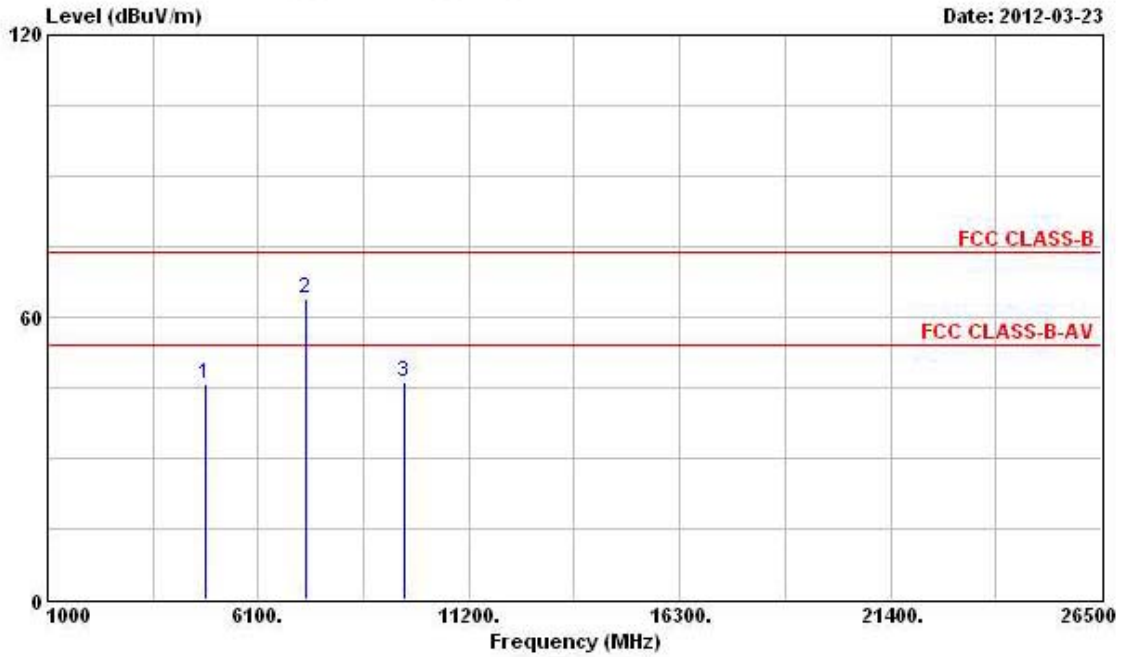

	Freq	Level	Over Limit	Limit Line	ReadAntenna Level	Antenna Factor	Cable Loss	Preamp Factor	Remark	Rnt Pos	Table Pos
	MHz	dBuV/m	dB	dBuV/m	dBuV	dB/m	dB	dB		cm	deg
1	4824.000	45.94	-8.06	54.00	40.40	35.76	4.58	34.80	PK	---	---
2	7236.000	63.99			55.59	37.85	5.63	35.08	Peak	---	---
3	9648.000	46.11			35.85	39.39	6.34	35.47	Peak	---	---

Note: The items 2 and 3 are on un-restricted band, so the limit is -20dB for the field strength of the fundamental emissions (see section 3.6.7).

Vertical

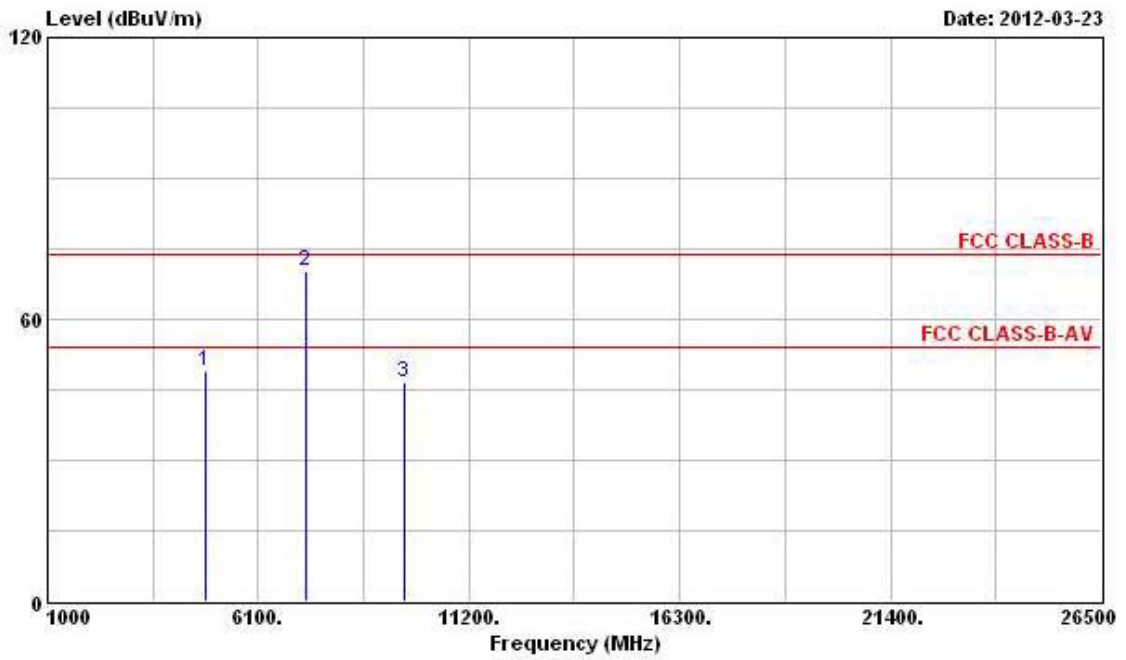

	Freq	Level	Over Limit	Limit Line	ReadAntenna Level	Antenna Factor	Cable Loss	Preamp Factor	Remark	Ant Pos	Table Pos
	MHz	dBuV/m	dB	dBuV/m	dBuV	dB/m	dB	dB		cm	deg
1	4824.000	48.94	-5.06	54.00	44.03	35.13	4.58	34.80	PK	---	---
2	7236.000	70.18			62.73	36.90	5.63	35.08	Peak	---	---
3	9648.000	46.71			37.25	38.59	6.34	35.47	Peak	---	---

Note: The items 2 and 3 are on un-restricted band, so the limit is -20dB for the field strength of the fundamental emissions (see section 3.6.7).

Final Test Date	Mar. 23, 2011	Test Site No.	03CH02-HY
Temperature	24.9°C	Humidity	53%
Test Engineer	Streak	Configuration	802.11b Ch. 6

Horizontal

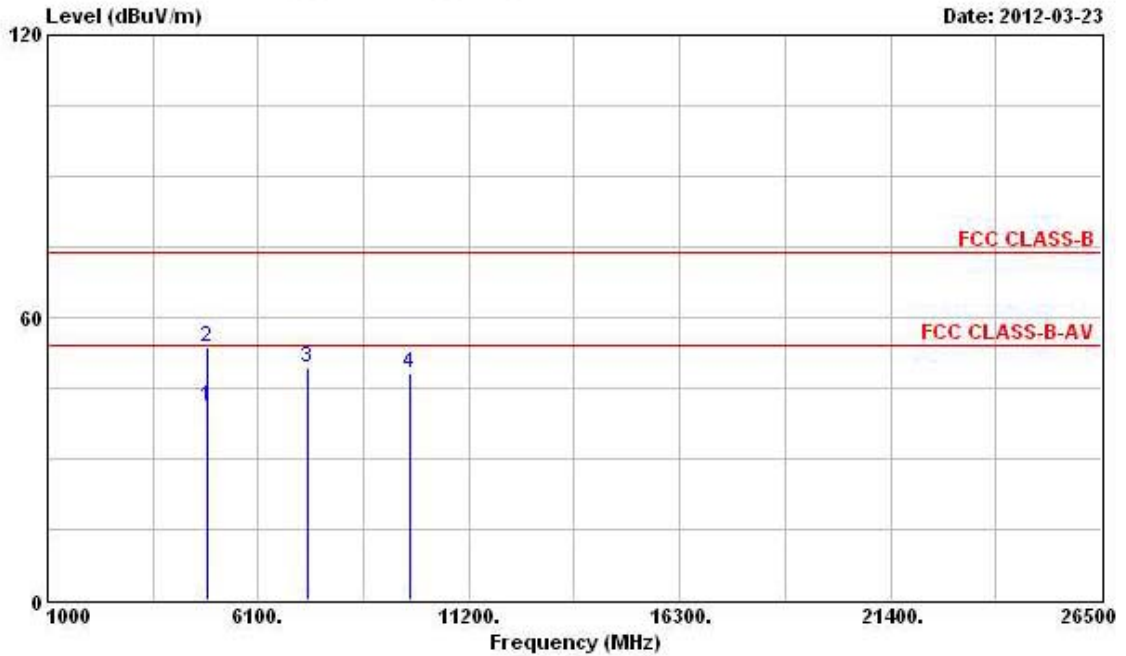

	Freq	Level	Over Limit	Limit Line	ReadAntenna Level	Antenna Factor	Cable Loss	Preamp Factor	Remark	Ant Pos	Table Pos
	MHz	dBuV/m	dB	dBuV/m	dBuV	dB/m	dB	dB		cm	deg
1	4874.000	41.08	-12.92	54.00	35.42	35.83	4.61	34.78	Average	---	---
2	4874.000	53.82	-20.18	74.00	48.16	35.83	4.61	34.78	Peak	---	---
3	7311.000	49.44	-4.56	54.00	41.04	37.86	5.64	35.10	PK	---	---
4	9748.000	48.07			37.68	39.51	6.36	35.48	Peak	---	---

Note: The item 4 is on un-restricted band, so the limit is -20dB for the field strength of the fundamental emissions (see section 3.6.7).

Vertical

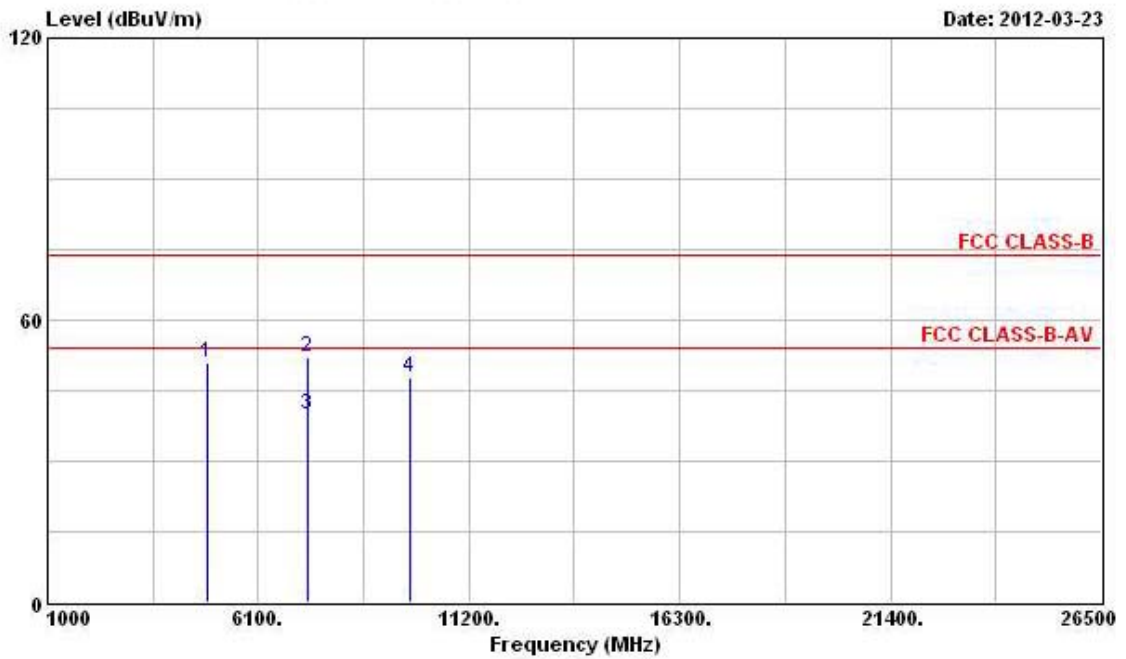

	Freq	Level	Over Limit	Limit Line	ReadAntenna Level	Antenna Factor	Cable Loss	Preamp Factor	Remark	Ant Pos	Table Pos
	MHz	dBuV/m	dB	dBuV/m	dBuV	dB/m	dB	dB		cm	deg
1	4874.000	50.75	-3.25	54.00	45.74	35.18	4.61	34.78	PK	---	---
2	7311.000	52.21	-21.79	74.00	44.75	36.92	5.64	35.10	Peak	---	---
3	7311.000	39.82	-14.18	54.00	32.36	36.92	5.64	35.10	Average	---	---
4	9748.000	47.79			38.20	38.71	6.36	35.48	Peak	---	---

Note: The item 4 is on un-restricted band, so the limit is -20dB for the field strength of the fundamental emissions (see section 3.6.7).

Final Test Date	Mar. 23, 2011	Test Site No.	03CH02-HY
Temperature	24.9°C	Humidity	53%
Test Engineer	Streak	Configuration	802.11b Ch. 11

Horizontal

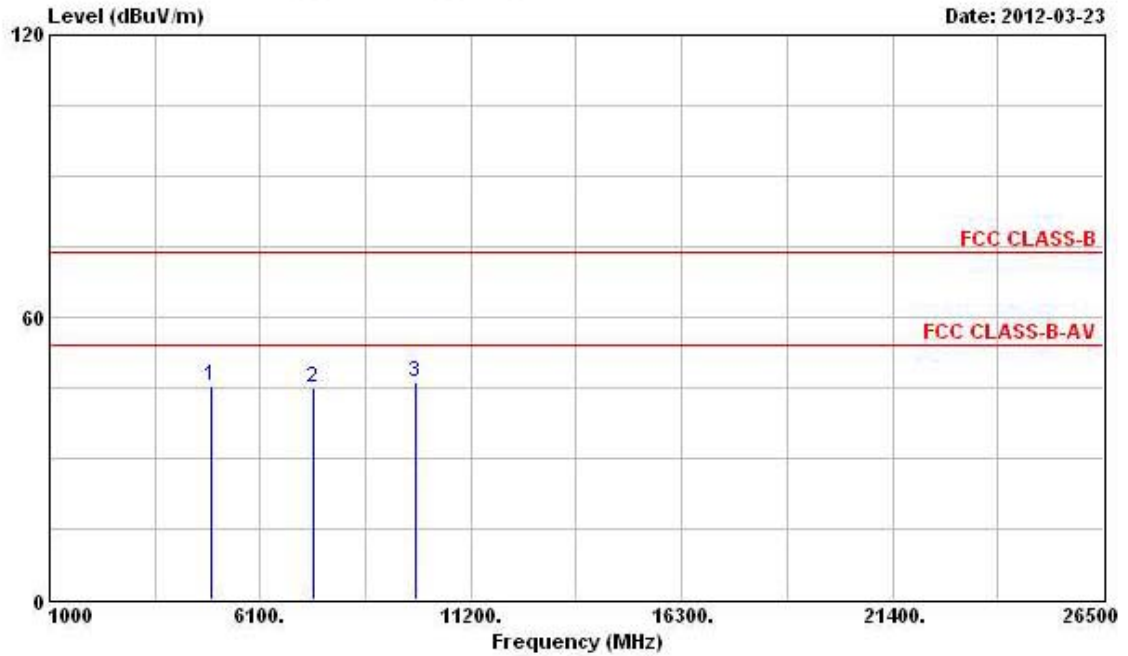

	Freq	Level	Over Limit	Limit Line	ReadAntenna Level	Antenna Factor	Cable Loss	Preamp Factor	Remark	Ant Pos	Table Pos
	MHz	dBuV/m	dB	dBuV/m	dBuV	dB/m	dB	dB		cm	deg
1	4924.000	45.33	-8.67	54.00	39.52	35.90	4.68	34.77	PK	---	---
2	7386.000	45.02	-8.98	54.00	36.61	37.88	5.65	35.12	PK	---	---
3	9848.000	46.35			35.85	39.61	6.38	35.49	Peak	---	---

Note: The item 3 is on un-restricted band, so the limit is -20dB for the field strength of the fundamental emissions (see section 3.6.7).

Vertical

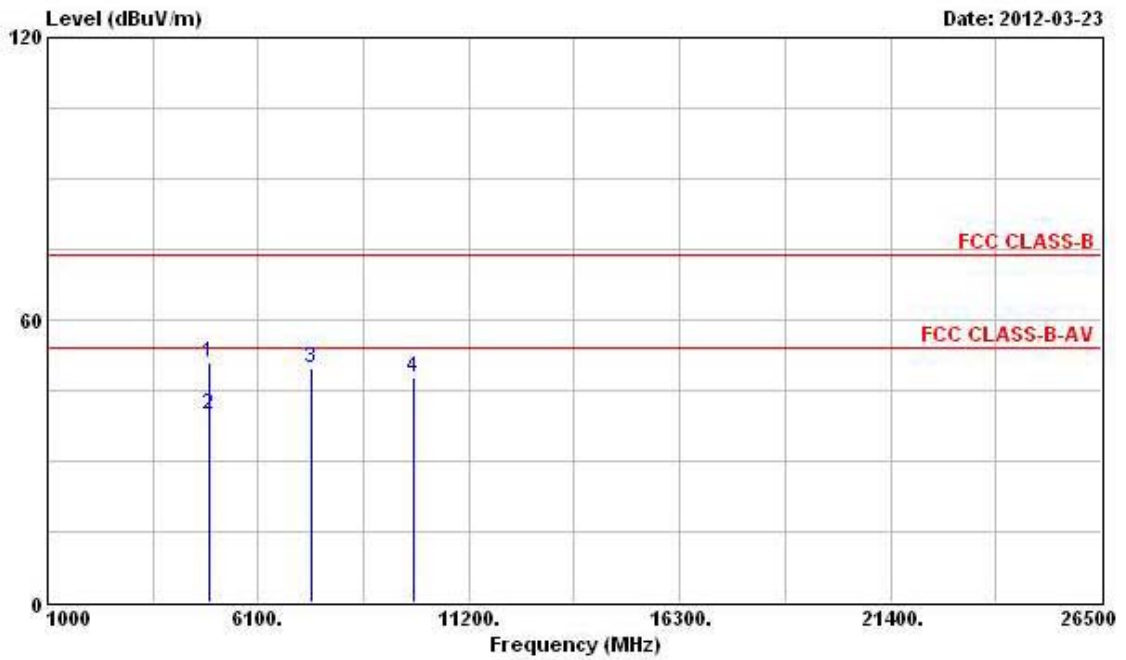

	Freq	Level	Over Limit	Limit Line	Read Level	Antenna Factor	Cable Loss	Preamp Factor	Remark	Ant Pos	Table Pos
	MHz	dBuV/m	dB	dBuV/m	dBuV	dB/m	dB	dB		cm	deg
1	4924.000	51.05	-22.95	74.00	45.91	35.23	4.68	34.77	Peak	---	---
2	4924.000	40.00	-14.00	54.00	34.86	35.23	4.68	34.77	Average	---	---
3	7386.000	49.63	-4.37	54.00	42.14	36.96	5.65	35.12	PK	---	---
4	9848.000	47.74			38.04	38.81	6.38	35.49	Peak	---	---

N Note: The item 4 is on un-restricted band, so the limit is -20dB for the field strength of the fundamental emissions (see section 3.6.7).

Final Test Date	Mar. 23, 2011	Test Site No.	03CH02-HY
Temperature	24.9°C	Humidity	53%
Test Engineer	Streak	Configuration	802.11g Ch. 1

Horizontal

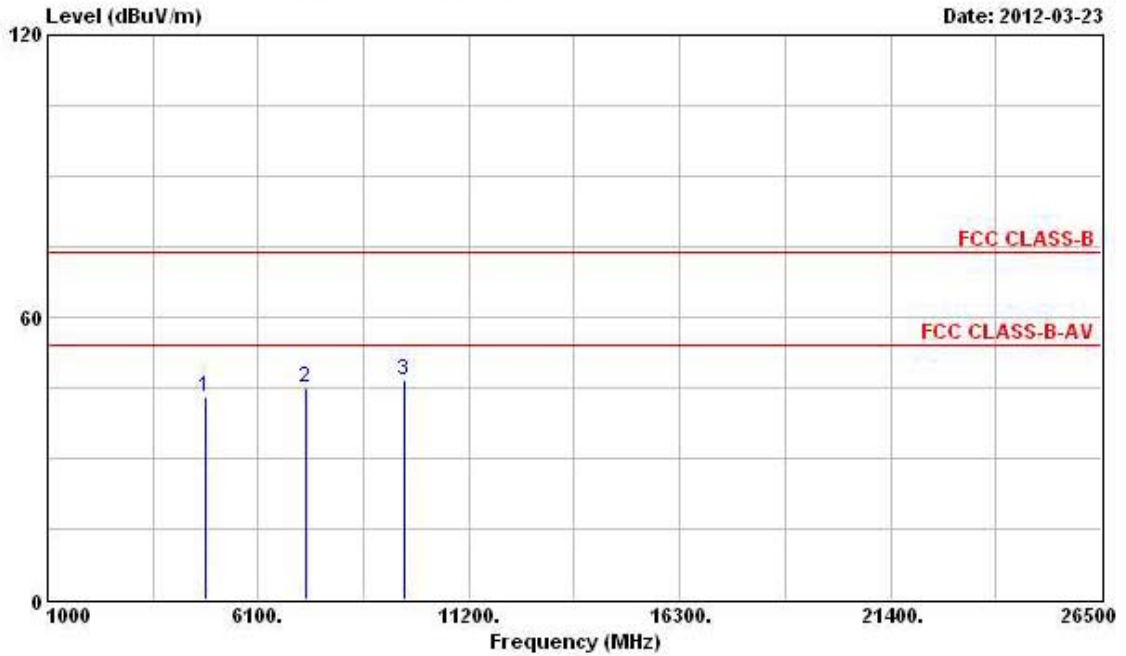

	Freq	Level	Over Limit	Limit Line	ReadAntenna Level	Antenna Factor	Cable Loss	Preamp Factor	Remark	Ant Pos	Table Pos
	MHz	dBuV/m	dB	dBuV/m	dBuV	dB/m	dB	dB		cm	deg
1	4824.000	43.10	-10.90	54.00	37.56	35.76	4.58	34.80	PK	---	---
2	7236.000	45.17			36.77	37.85	5.63	35.08	Peak	---	---
3	9648.000	46.69			36.43	39.39	6.34	35.47	Peak	---	---

Note: The items 2 and 3 are on un-restricted band, so the limit is -20dB for the field strength of the fundamental emissions (see section 3.6.7).

Vertical

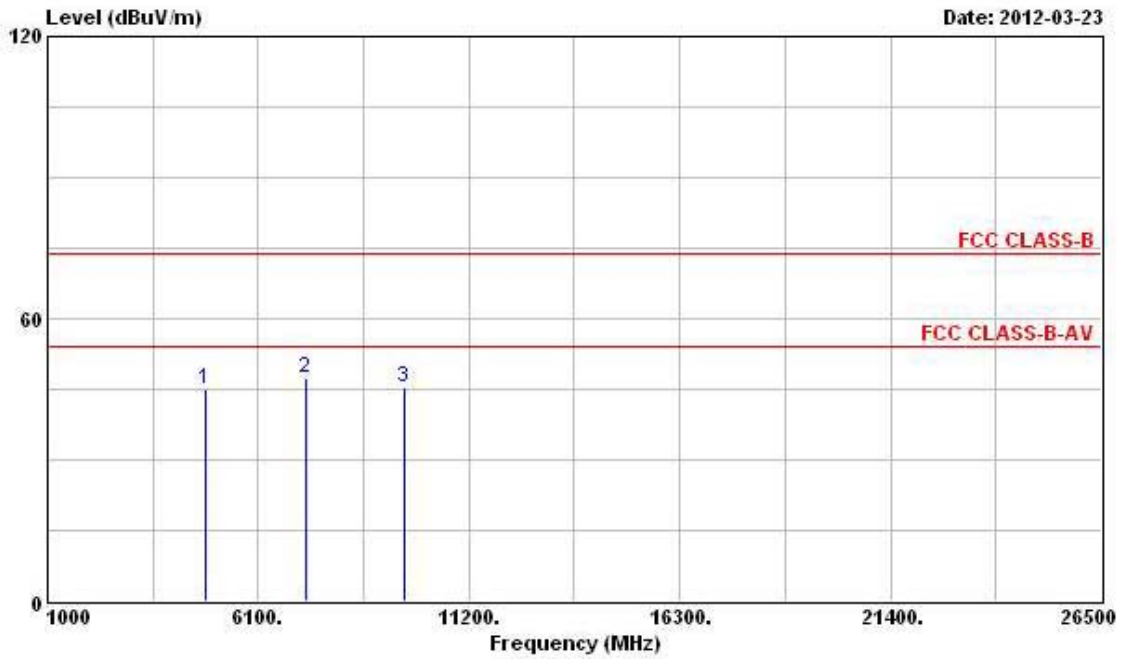

	Freq	Level	Over Limit	Limit Line	Read Level	Antenna Factor	Cable Loss	Preamp Factor	Remark	Ant Pos	Table Pos
	MHz	dBuV/m	dB	dBuV/m	dBuV	dB/m	dB	dB		cm	deg
1	4824.000	45.05	-8.95	54.00	40.14	35.13	4.58	34.80	PK	---	---
2	7236.000	47.47			40.02	36.90	5.63	35.08	Peak	---	---
3	9648.000	45.41			35.95	38.59	6.34	35.47	Peak	---	---

Note: The items 2 and 3 are on un-restricted band, so the limit is -20dB for the field strength of the fundamental emissions (see section 3.6.7).

Final Test Date	Mar. 23, 2011	Test Site No.	03CH02-HY
Temperature	24.9°C	Humidity	53%
Test Engineer	Streak	Configuration	802.11g Ch. 6

Horizontal

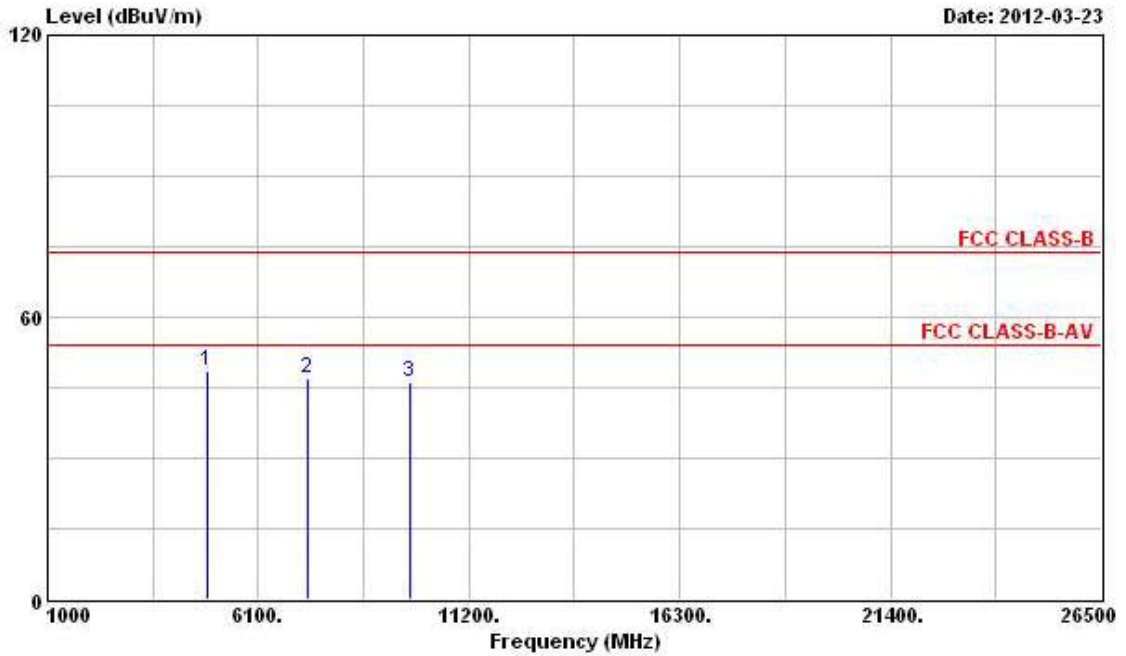

	Freq	Level	Over Limit	Limit Line	ReadAntenna Level	Antenna Factor	Cable Loss	Preamp Factor	Remark	Ant Pos	Table Pos
	MHz	dBuV/m	dB	dBuV/m	dBuV	dB/m	dB	dB		cm	deg
1	4874.000	48.75	-5.25	54.00	43.09	35.83	4.61	34.78	PK	---	---
2	7311.000	47.04	-6.96	54.00	38.64	37.86	5.64	35.10	PK	---	---
3	9748.000	46.03			35.64	39.51	6.36	35.48	Peak	---	---

Note: The item 3 is on un-restricted band, so the limit is -20dB for the field strength of the fundamental emissions (see section 3.6.7).

Vertical

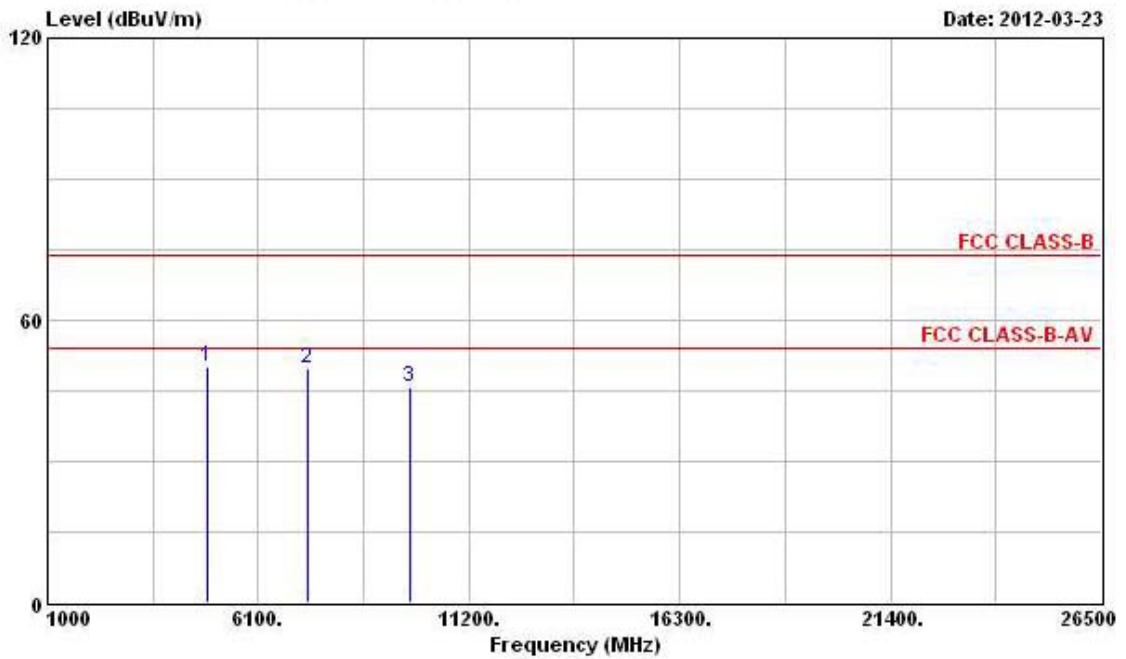

	Freq	Level	Over Limit	Limit Line	ReadAntenna Level	Antenna Factor	Cable Loss	Preamp Factor	Remark	Ant Pos	Table Pos
	MHz	dBuV/m	dB	dBuV/m	dBuV	dB/m	dB	dB		cm	deg
1	4874.000	50.03	-3.97	54.00	45.02	35.18	4.61	34.78	PK	---	---
2	7311.000	49.59	-4.41	54.00	42.13	36.92	5.64	35.10	PK	---	---
3	9748.000	45.60			36.01	38.71	6.36	35.48	Peak	---	---

Note: The item 3 is on un-restricted band, so the limit is -20dB for the field strength of the fundamental emissions (see section 3.6.7).

Final Test Date	Mar. 23, 2011	Test Site No.	03CH02-HY
Temperature	24.9°C	Humidity	53%
Test Engineer	Streak	Configuration	802.11g Ch. 11

Horizontal

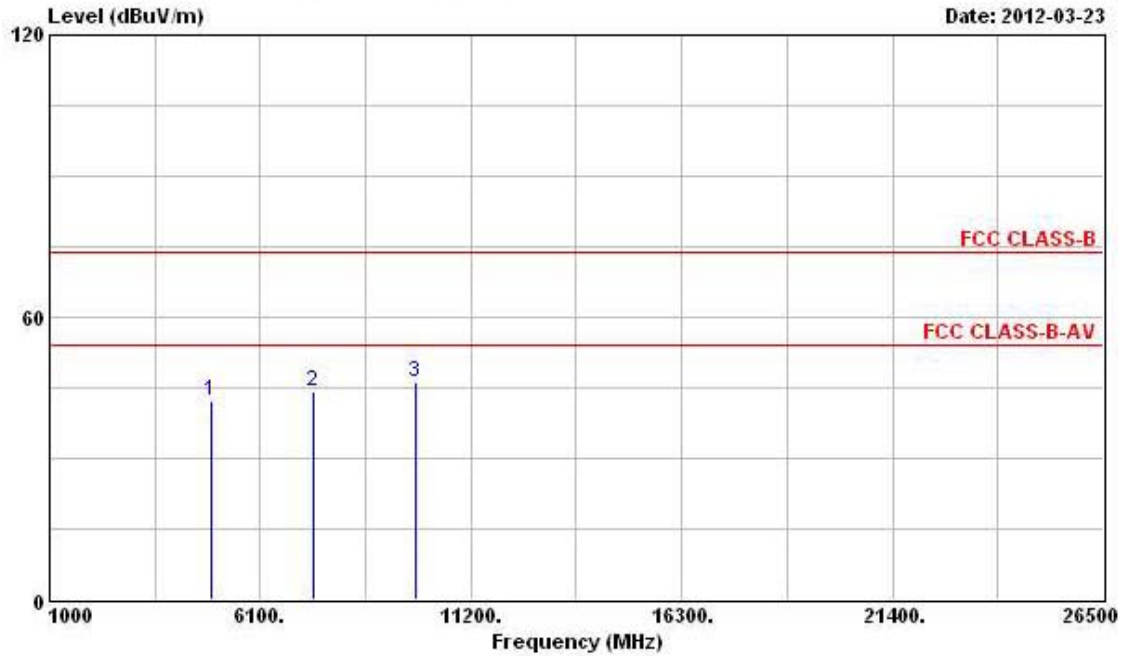

	Freq	Level	Over Limit	Limit Line	ReadAntenna Level	Antenna Factor	Cable Loss	Preamp Factor	Remark	Ant Pos	Table Pos
	MHz	dBuV/m	dB	dBuV/m	dBuV	dB/m	dB	dB		cm	deg
1	4924.000	42.31	-11.69	54.00	36.50	35.90	4.68	34.77	PK	---	---
2	7386.000	44.09	-9.91	54.00	35.68	37.88	5.65	35.12	PK	---	---
3	9848.000	46.37			35.87	39.61	6.38	35.49	Peak	---	---

Note: The item 3 is on un-restricted band, so the limit is -20dB for the field strength of the fundamental emissions (see section 3.6.7).

Vertical

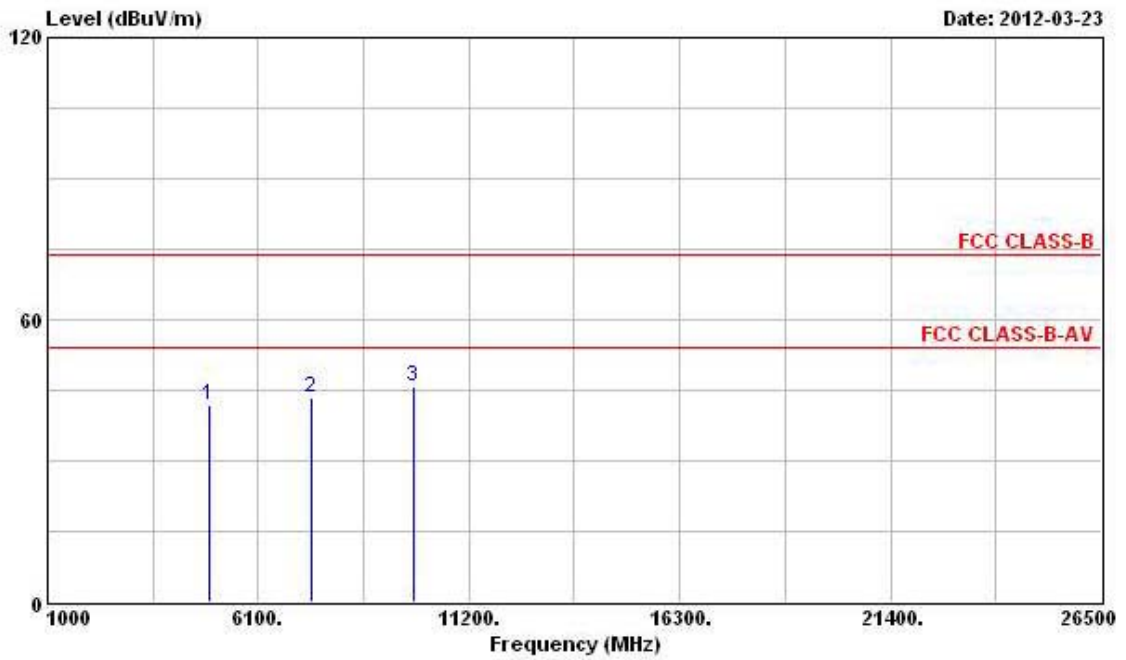

	Freq	Level	Over Limit	Limit Line	ReadAntenna Level	Antenna Factor	Cable Loss	Preamp	Remark	Ant Pos	Table Pos
	MHz	dBuV/m	dB	dBuV/m	dBuV	dB/m	dB	dB		cm	deg
1	4924.000	41.79	-12.21	54.00	36.65	35.23	4.68	34.77	PK	---	---
2	7386.000	43.30	-10.70	54.00	35.81	36.96	5.65	35.12	PK	---	---
3	9848.000	45.85			36.15	38.81	6.38	35.49	Peak	---	---

Note: The item 3 is on un-restricted band, so the limit is -20dB for the field strength of the fundamental emissions (see section 3.6.7).

Final Test Date	Mar. 23, 2011	Test Site No.	03CH02-HY
Temperature	24.9°C	Humidity	53%
Test Engineer	Streak	Configuration	802.11n (20MHz) Ch. 1

Horizontal

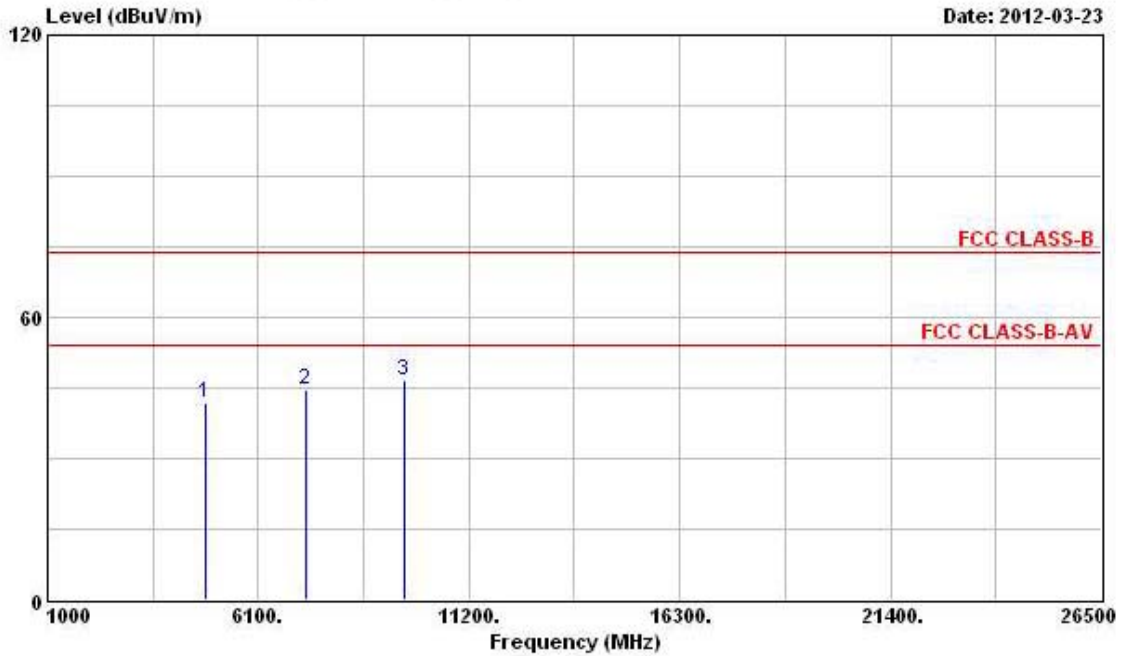

	Freq	Level	Over Limit	Limit Line	ReadAntenna Level	Antenna Factor	Cable Loss	Preamp Factor	Remark	Ant Pos	Table Pos
	MHz	dBuV/m	dB	dBuV/m	dBuV	dB/m	dB	dB		cm	deg
1	4824.000	41.89	-12.11	54.00	36.35	35.76	4.58	34.80	PK	---	---
2	7236.000	44.43			36.03	37.85	5.63	35.08	Peak	---	---
3	9648.000	46.51			36.25	39.39	6.34	35.47	Peak	---	---

Note: The items 2 and 3 are on un-restricted band, so the limit is -20dB for the field strength of the fundamental emissions (see section 3.6.7).

Vertical

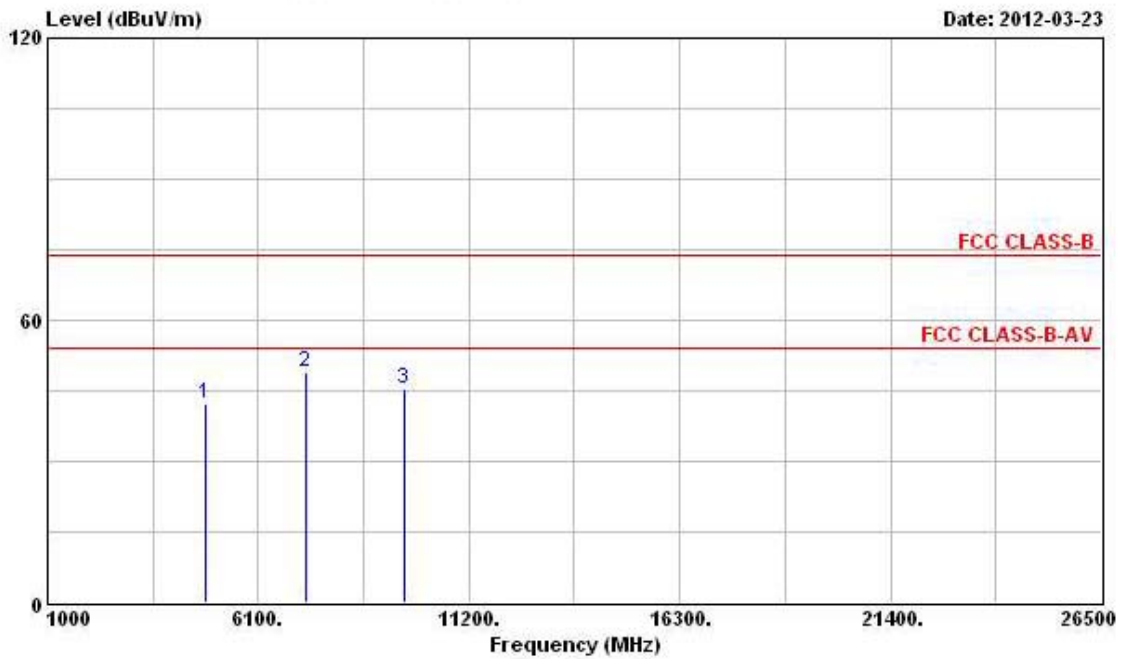

	Freq	Level	Over Limit	Limit Line	ReadAntenna Level	Antenna Factor	Cable Loss	Preamp Factor	Remark	Ant Pos	Table Pos
	MHz	dBuV/m	dB	dBuV/m	dBuV	dB/m	dB	dB		cm	deg
1	4824.000	42.11	-11.89	54.00	37.20	35.13	4.58	34.80	PK	---	---
2	7236.000	49.09			41.64	36.90	5.63	35.08	Peak	---	---
3	9648.000	45.55			36.09	38.59	6.34	35.47	Peak	---	---

Note: The items 2 and 3 are on un-restricted band, so the limit is -20dB for the field strength of the fundamental emissions (see section 3.6.7).

Final Test Date	Mar. 23, 2011	Test Site No.	03CH02-HY
Temperature	24.9°C	Humidity	53%
Test Engineer	Streak	Configuration	802.11n (20MHz) Ch. 6

Horizontal

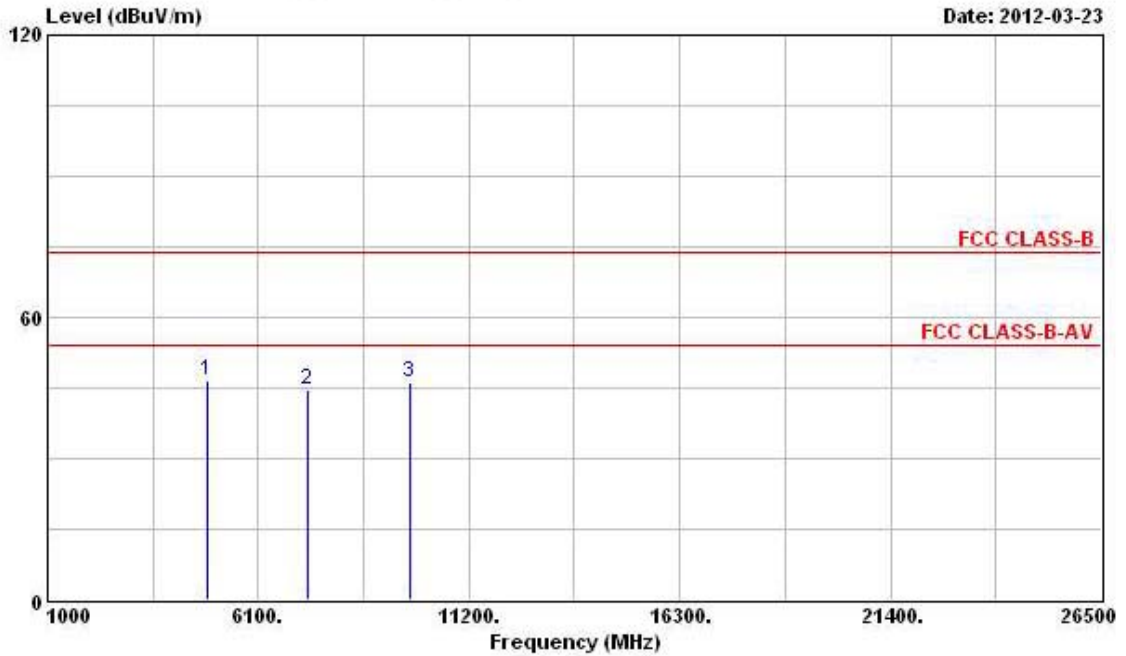

	Freq	Level	Over Limit	Limit Line	ReadAntenna Level	Antenna Factor	Cable Loss	Preamp Factor	Remark	Ant Pos	Table Pos
	MHz	dBuV/m	dB	dBuV/m	dBuV	dB/m	dB	dB		cm	deg
1	4874.000	46.61	-7.39	54.00	40.95	35.83	4.61	34.78	PK	---	---
2	7311.000	44.79	-9.21	54.00	36.39	37.86	5.64	35.10	PK	---	---
3	9748.000	46.25			35.86	39.51	6.36	35.48	Peak	---	---

Note: The item 3 is on un-restricted band, so the limit is -20dB for the field strength of the fundamental emissions (see section 3.6.7).

Vertical

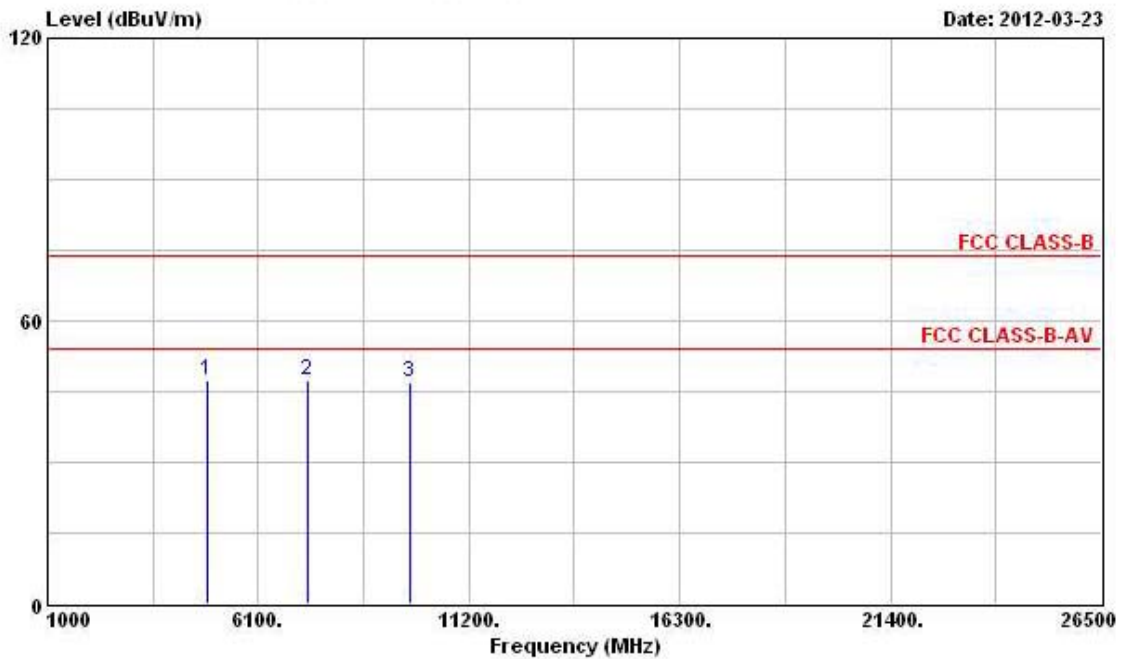

	Freq	Level	Over Limit	Limit Line	ReadAntenna Level	Antenna Factor	Cable Loss	Preamp Factor	Remark	Ant Pos	Table Pos
	MHz	dBuV/m	dB	dBuV/m	dBuV	dB/m	dB	dB		cm	deg
1	4874.000	47.31	-6.69	54.00	42.30	35.18	4.61	34.78	PK	---	---
2	7311.000	47.29	-6.71	54.00	39.83	36.92	5.64	35.10	PK	---	---
3	9748.000	46.78			37.19	38.71	6.36	35.48	Peak	---	---

Note: The item 3 is on un-restricted band, so the limit is -20dB for the field strength of the fundamental emissions (see section 3.6.7).

Final Test Date	Mar. 23, 2011	Test Site No.	03CH02-HY
Temperature	24.9°C	Humidity	53%
Test Engineer	Streak	Configuration	802.11n (20MHz) Ch. 11

Horizontal

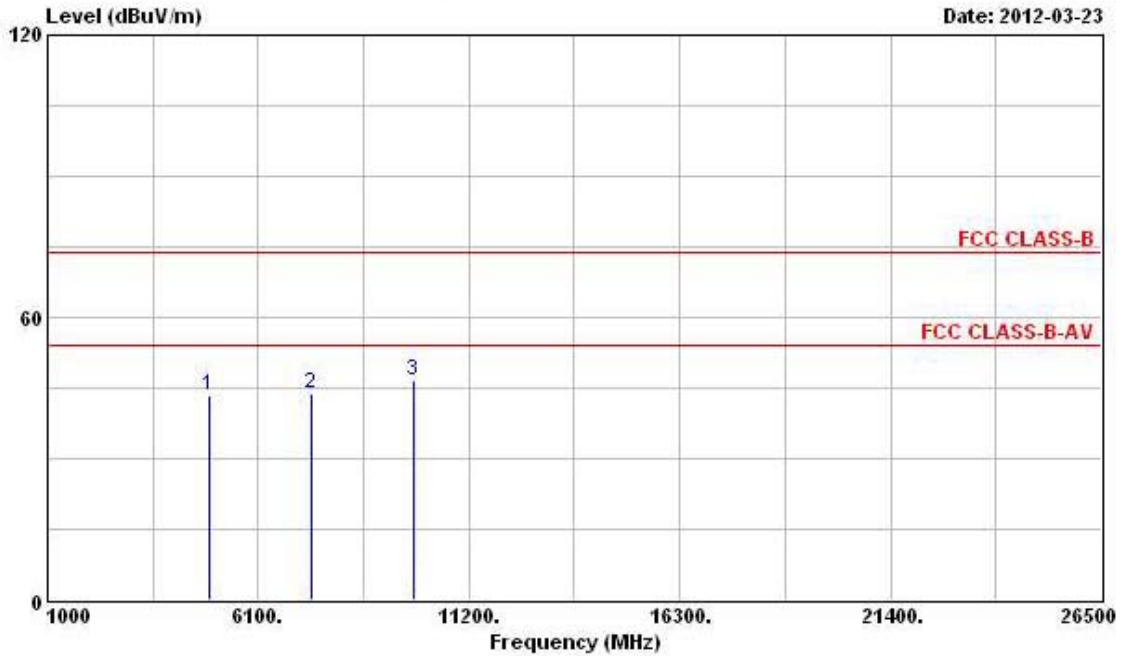

	Freq	Level	Over Limit	Limit Line	ReadAntenna Level	Antenna Factor	Cable Loss	Preamp Factor	Remark	Ant Pos	Table Pos
	MHz	dBuV/m	dB	dBuV/m	dBuV	dB/m	dB	dB		cm	deg
1	4924.000	43.58	-10.42	54.00	37.77	35.90	4.68	34.77	PK	---	---
2	7386.000	43.90	-10.10	54.00	35.49	37.88	5.65	35.12	PK	---	---
3	9848.000	46.72			36.22	39.61	6.38	35.49	Peak	---	---

Note: The item 3 is on un-restricted band, so the limit is -20dB for the field strength of the fundamental emissions (see section 3.6.7).

Vertical

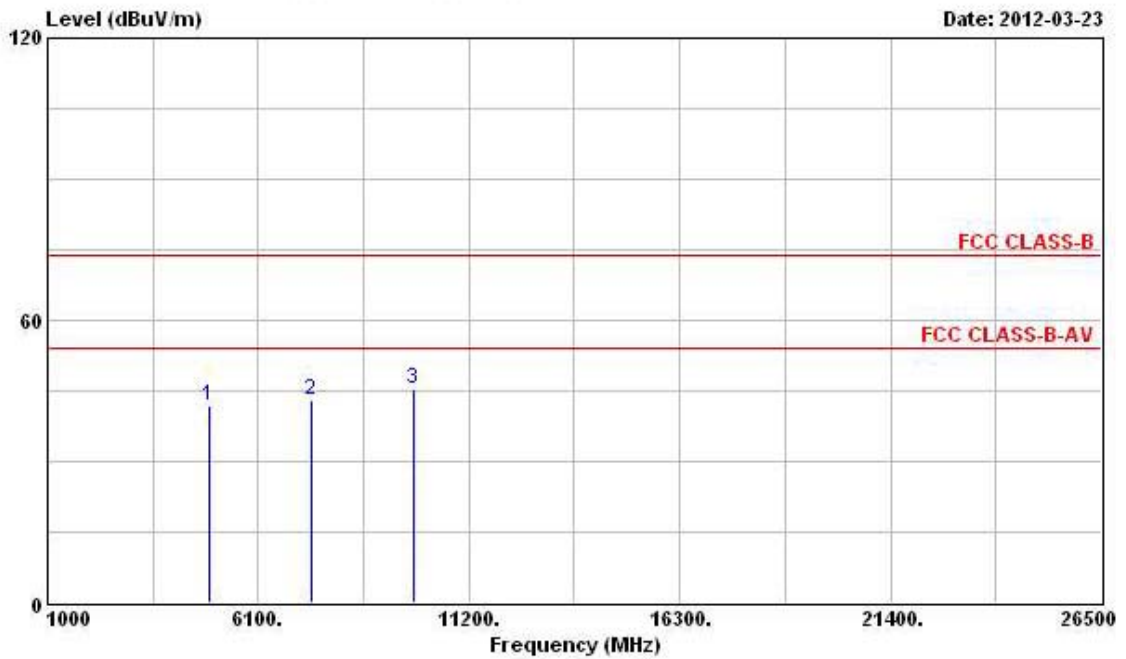

	Freq	Level	Over Limit	Limit Line	ReadAntenna Level	Antenna Factor	Cable Loss	Preamp Factor	Remark	Ant Pos	Table Pos
	MHz	dBUV/m	dB	dBUV/m	dBuV	dB/m	dB	dB		cm	deg
1	4924.000	41.75	-12.25	54.00	36.61	35.23	4.68	34.77	PK	---	---
2	7386.000	43.14	-10.86	54.00	35.65	36.96	5.65	35.12	PK	---	---
3	9848.000	45.32			35.62	38.81	6.38	35.49	Peak	---	---

Note: The item 3 is on un-restricted band, so the limit is -20dB for the field strength of the fundamental emissions (see section 3.6.7).

Final Test Date	Mar. 23, 2011	Test Site No.	03CH02-HY
Temperature	24.9°C	Humidity	53%
Test Engineer	Streak	Configuration	802.11n (40MHz) Ch. 3

Horizontal

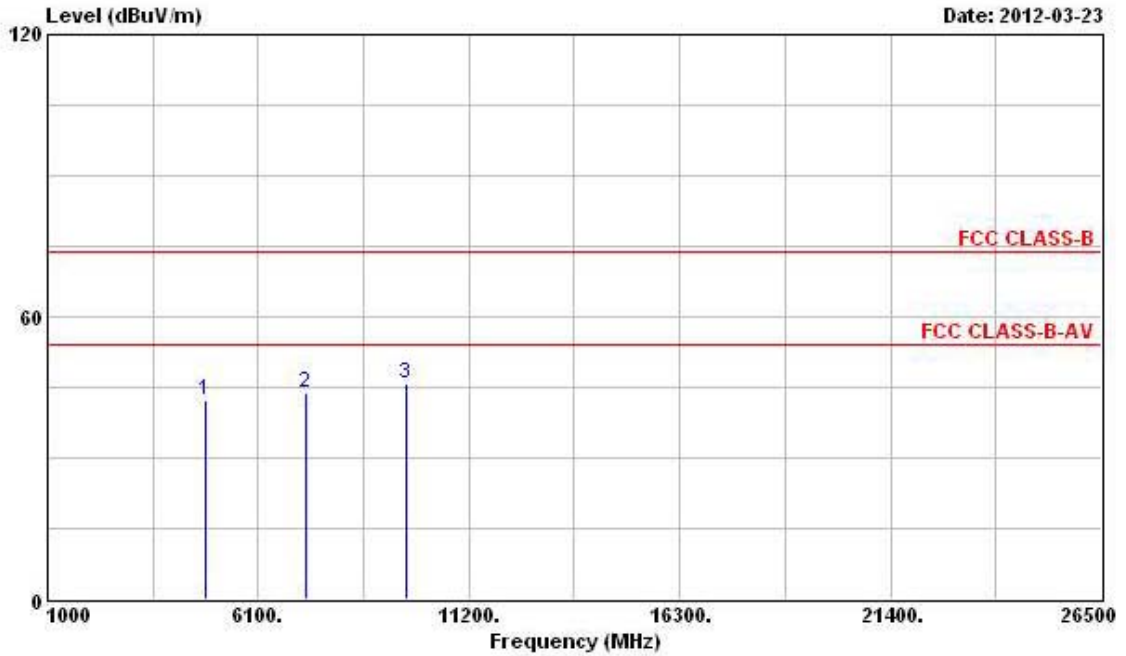

	Freq	Level	Over Limit	Limit Line	ReadAntenna Level	Antenna Factor	Cable Loss	Preamp Factor	Remark	Ant Pos	Table Pos
	MHz	dBuV/m	dB	dBuV/m	dBuV	dB/m	dB	dB		cm	deg
1	4844.000	42.16	-11.84	54.00	36.56	35.78	4.61	34.79	PK	---	---
2	7266.000	43.93	-10.07	54.00	35.53	37.86	5.63	35.09	PK	---	---
3	9688.000	45.98			35.68	39.43	6.35	35.48	Peak	---	---

Note: The item 3 is on un-restricted band, so the limit is -20dB for the field strength of the fundamental emissions (see section 3.6.7).

Vertical

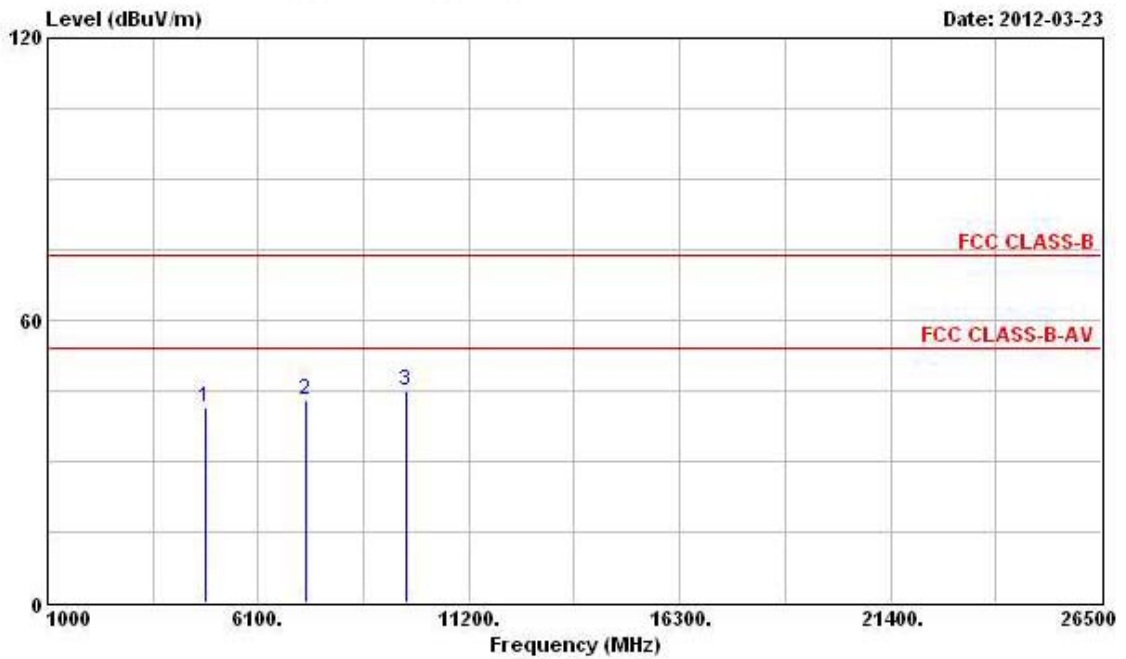

	Freq	Level	Over Limit	Limit Line	ReadAntenna Level	Antenna Factor	Cable Loss	Preamp Factor	Remark	Ant Pos	Table Pos
	MHz	dBuV/m	dB	dBuV/m	dBuV	dB/m	dB	dB		cm	deg
1	4844.000	41.30	-12.70	54.00	36.34	35.14	4.61	34.79	PK	---	---
2	7266.000	42.99	-11.01	54.00	35.54	36.91	5.63	35.09	PK	---	---
3	9688.000	45.16			35.66	38.63	6.35	35.48	Peak	---	---

Note: The item 3 is on un-restricted band, so the limit is -20dB for the field strength of the fundamental emissions (see section 3.6.7).

Final Test Date	Mar. 23, 2011	Test Site No.	03CH02-HY
Temperature	24.9°C	Humidity	53%
Test Engineer	Streak	Configuration	802.11n (40MHz) Ch. 6

Horizontal

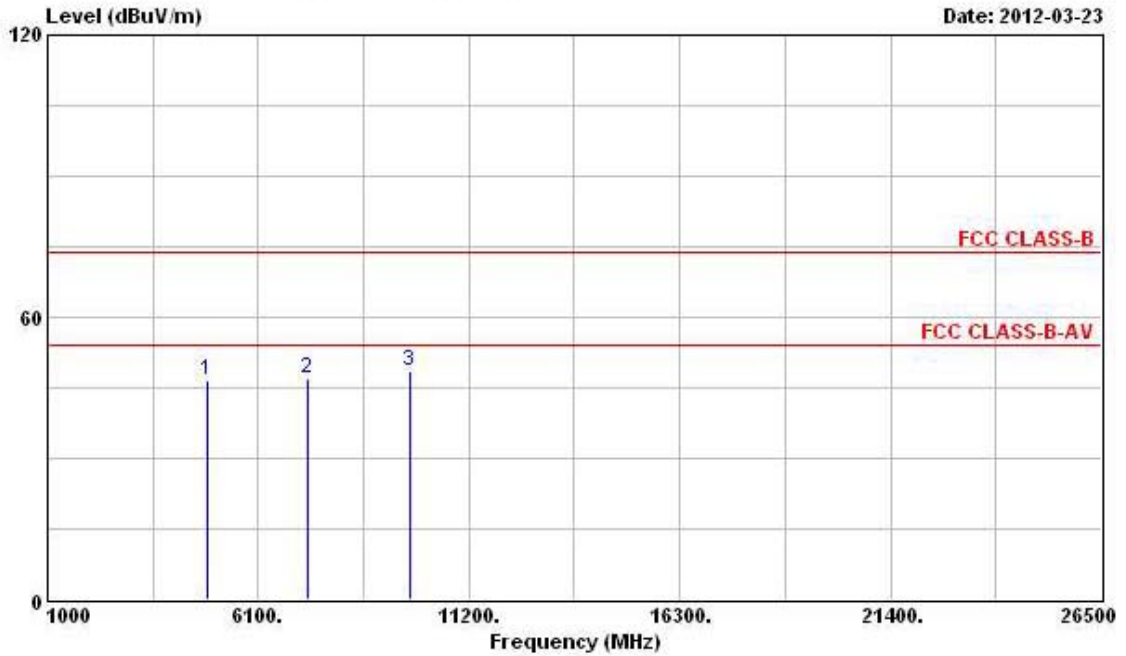

	Freq	Level	Over Limit	Limit Line	ReadAntenna Level	Antenna Factor	Cable Loss	Preamp Factor	Remark	Ant Pos	Table Pos
	MHz	dBuV/m	dB	dBuV/m	dBuV	dB/m	dB	dB		cm	deg
1	4874.000	46.63	-7.37	54.00	40.97	35.83	4.61	34.78	PK	---	---
2	7311.000	46.88	-7.12	54.00	38.48	37.86	5.64	35.10	PK	---	---
3	9748.000	48.75			38.36	39.51	6.36	35.48	Peak	---	---

Note: The item 3 is on un-restricted band, so the limit is -20dB for the field strength of the fundamental emissions (see section 3.6.7).

Vertical

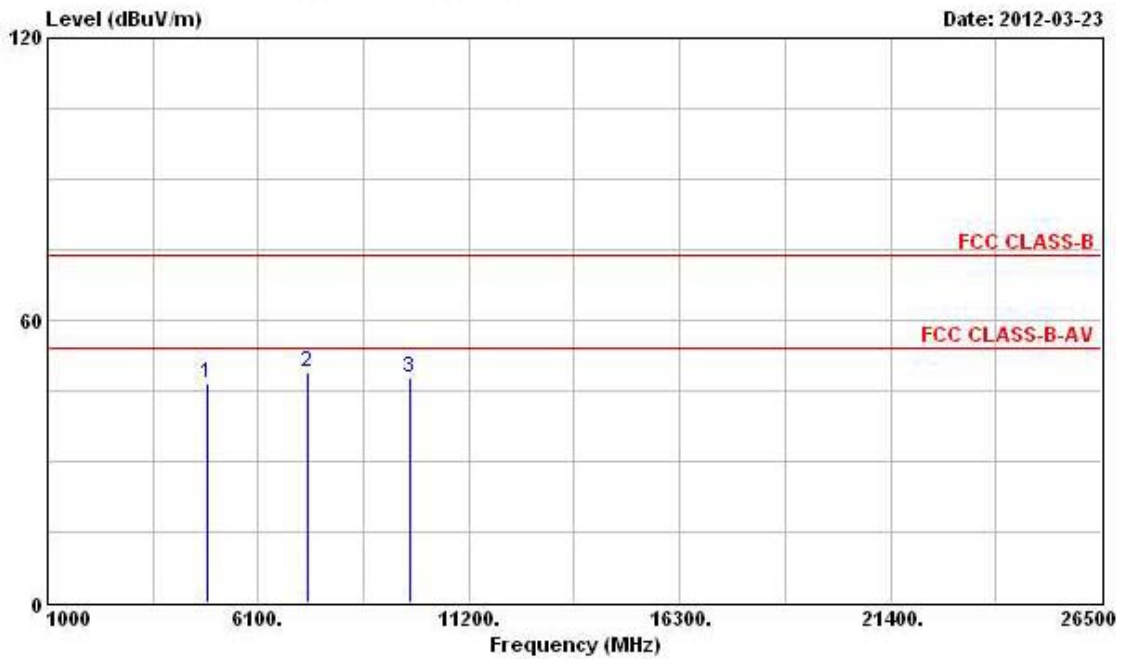

	Freq	Level	Over Limit	Limit Line	ReadAntenna Level	Antenna Factor	Cable Loss	Preamp Factor	Remark	Ant Pos	Table Pos
	MHz	dBuV/m	dB	dBuV/m	dBuV	dB/m	dB	dB		cm	deg
1	4874.000	46.74	-7.26	54.00	41.73	35.18	4.61	34.78	PK	---	---
2	7311.000	49.05	-4.95	54.00	41.59	36.92	5.64	35.10	PK	---	---
3	9748.000	47.74			38.15	38.71	6.36	35.48	Peak	---	---

Note: The item 3 is on un-restricted band, so the limit is -20dB for the field strength of the fundamental emissions (see section 3.6.7).

Final Test Date	Mar. 23, 2011	Test Site No.	03CH02-HY
Temperature	24.9°C	Humidity	53%
Test Engineer	Streak	Configuration	802.11n (40MHz) Ch. 9

Horizontal

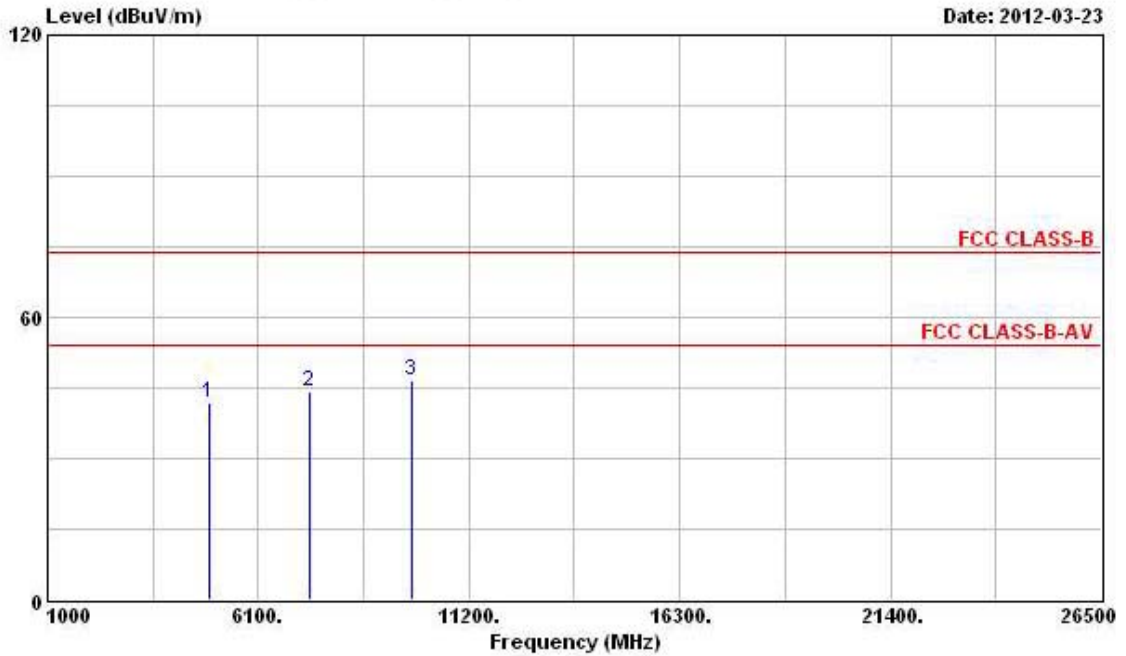

	Freq	Level	Over Limit	Limit Line	ReadAntenna Level	Antenna Factor	Cable Loss	Preamp Factor	Remark	Ant Pos	Table Pos
	MHz	dBuV/m	dB	dBuV/m	dBuV	dB/m	dB	dB		cm	deg
1	4904.000	41.97	-12.03	54.00	36.23	35.88	4.64	34.78	PK	---	---
2	7356.000	44.15	-9.85	54.00	35.75	37.87	5.64	35.11	PK	---	---
3	9808.000	46.49			36.03	39.57	6.37	35.48	Peak	---	---

Note: The item 3 is on un-restricted band, so the limit is -20dB for the field strength of the fundamental emissions (see section 3.6.7).

Vertical

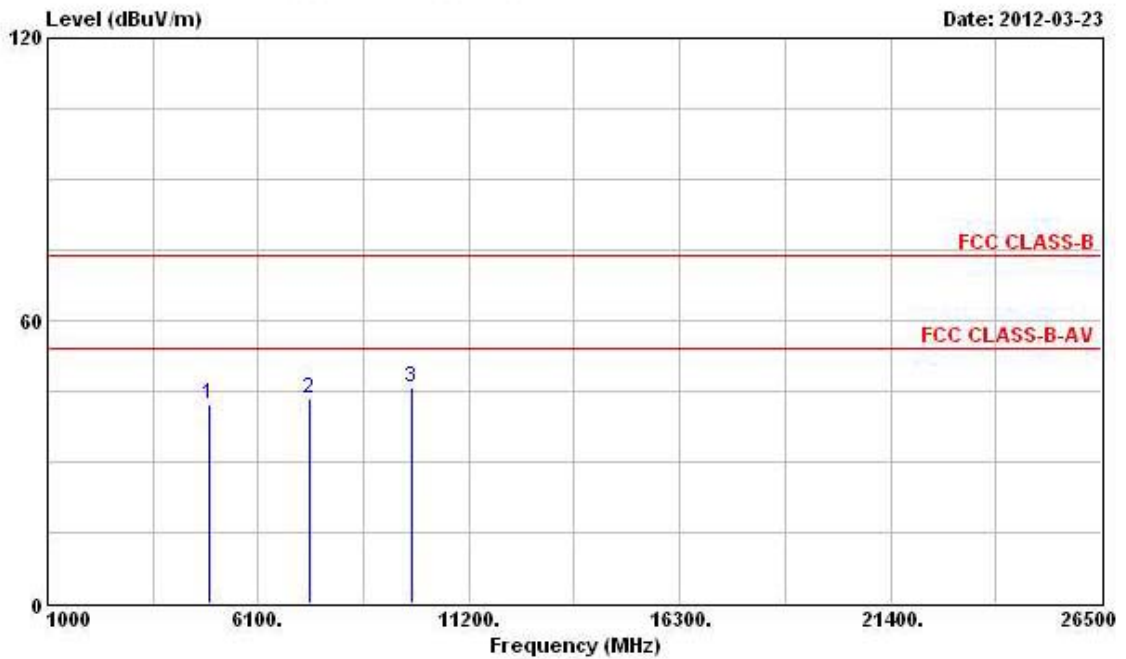

	Freq	Level	Over Limit	Limit Line	ReadAntenna Level	Antenna Factor	Cable Loss	Preamp Factor	Remark	Ant Pos	Table Pos
	MHz	dBuV/m	dB	dBuV/m	dBuV	dB/m	dB	dB		cm	deg
1	4904.000	42.32	-11.68	54.00	37.25	35.21	4.64	34.78	PK	---	---
2	7356.000	43.60	-10.40	54.00	36.13	36.94	5.64	35.11	PK	---	---
3	9808.000	45.91			36.25	38.77	6.37	35.48	Peak	---	---

Note: The item 3 is on un-restricted band, so the limit is -20dB for the field strength of the fundamental emissions (see section 3.6.7).

For Two Chains:

Final Test Date	Mar. 23, 2011	Test Site No.	03CH02-HY
Temperature	24.9°C	Humidity	53%
Test Engineer	Streak	Configuration	802.11n (20MHz) Ch. 1

Horizontal

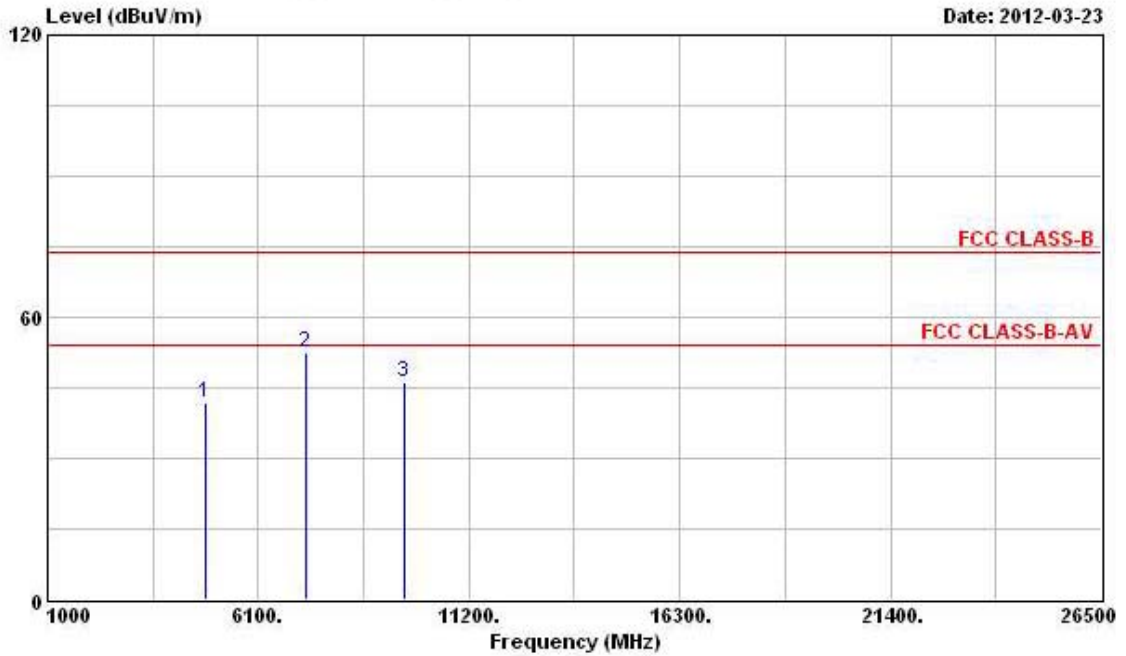

	Freq	Level	Over Limit	Limit Line	ReadAntenna Level	Antenna Factor	Cable Loss	Preamp Factor	Remark	Ant Pos	Table Pos
	MHz	dBuV/m	dB	dBuV/m	dBuV	dB/m	dB	dB		cm	deg
1	4824.000	41.77	-12.23	54.00	36.23	35.76	4.58	34.80	PK	---	---
2	7236.000	52.48			44.08	37.85	5.63	35.08	Peak	---	---
3	9648.000	46.31			36.05	39.39	6.34	35.47	Peak	---	---

Note: The items 2 and 3 are on un-restricted band, so the limit is -20dB for the field strength of the fundamental emissions (see section 3.6.7).

Vertical

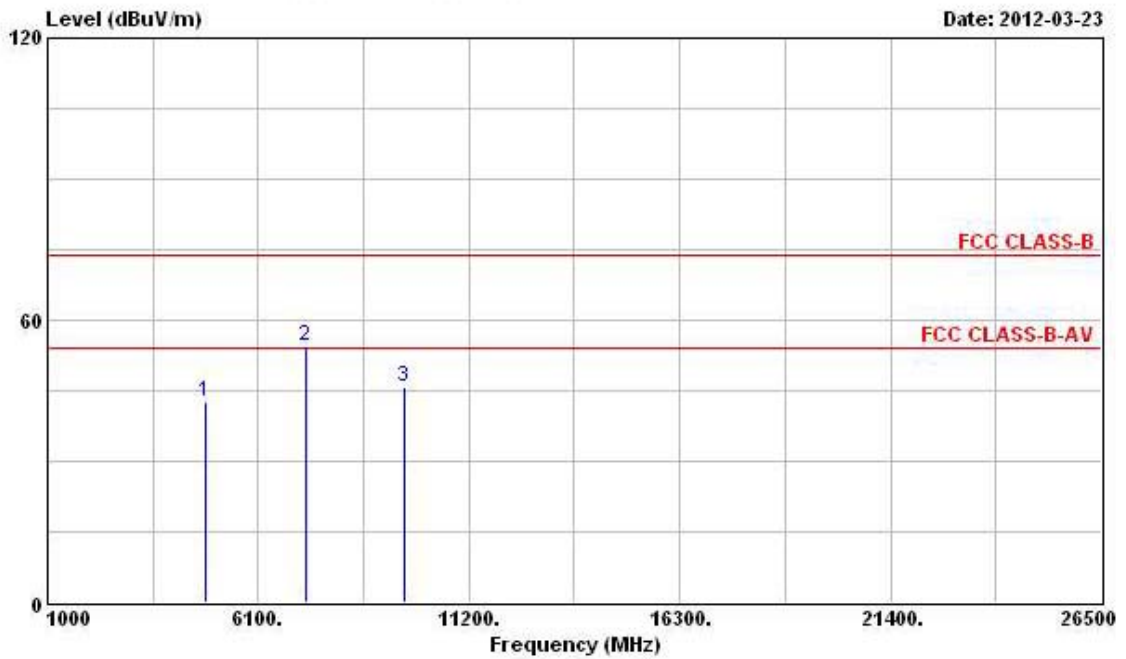

	Freq	Level	Over Limit	Limit Line	ReadAntenna Level	Antenna Factor	Cable Loss	Preamp Factor	Remark	Ant Pos	Table Pos
	MHz	dBuV/m	dB	dBuV/m	dBuV	dB/m	dB	dB		cm	deg
1	4824.000	42.69	-11.31	54.00	37.78	35.13	4.58	34.80	PK	---	---
2	7236.000	54.57			47.12	36.90	5.63	35.08	Peak	---	---
3	9648.000	45.91			36.45	38.59	6.34	35.47	Peak	---	---

Note: The items 2 and 3 are on un-restricted band, so the limit is -20dB for the field strength of the fundamental emissions (see section 3.6.7).

Final Test Date	Mar. 23, 2011	Test Site No.	03CH02-HY
Temperature	24.9°C	Humidity	53%
Test Engineer	Streak	Configuration	802.11n (20MHz) Ch. 6

Horizontal

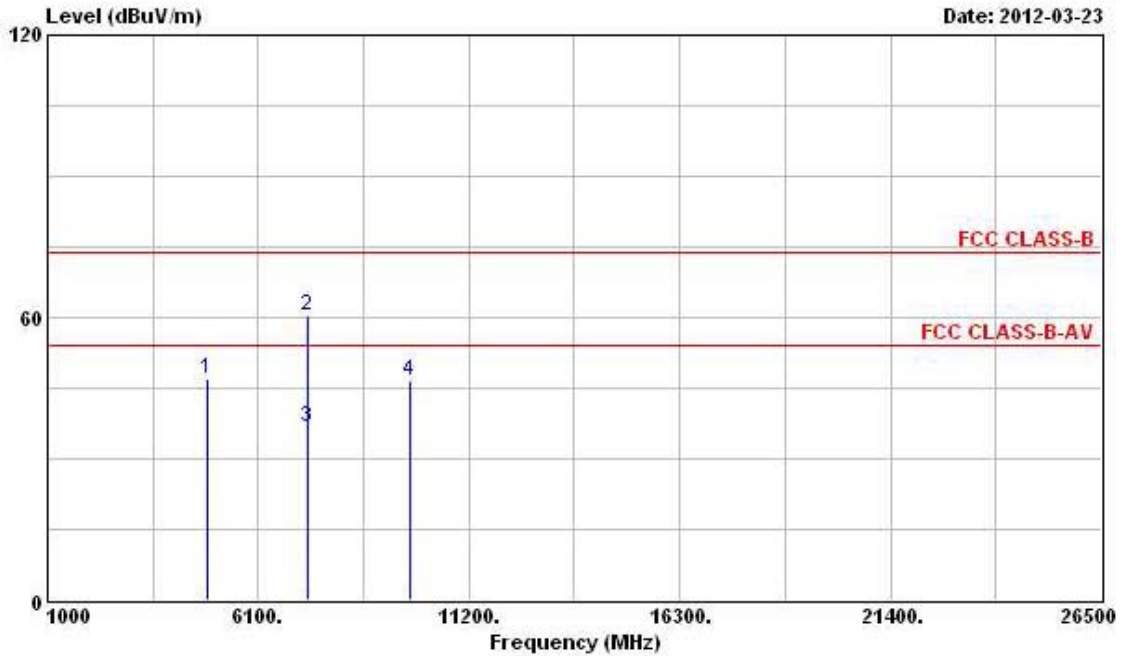

	Freq	Level	Over Limit	Limit Line	ReadAntenna Level	Antenna Factor	Cable Loss	Preamp Factor	Remark	Ant Pos	Table Pos
	MHz	dBuV/m	dB	dBuV/m	dBuV	dB/m	dB	dB		cm	deg
1	4874.000	47.02	-6.98	54.00	41.36	35.83	4.61	34.78	PK	---	---
2	7311.000	60.35	-13.65	74.00	51.95	37.86	5.64	35.10	Peak	---	---
3	7311.000	36.81	-17.19	54.00	28.41	37.86	5.64	35.10	Average	---	---
4	9748.000	46.47			36.08	39.51	6.36	35.48	Peak	---	---

Note: The item 4 is on un-restricted band, so the limit is -20dB for the field strength of the fundamental emissions (see section 3.6.7).

Vertical

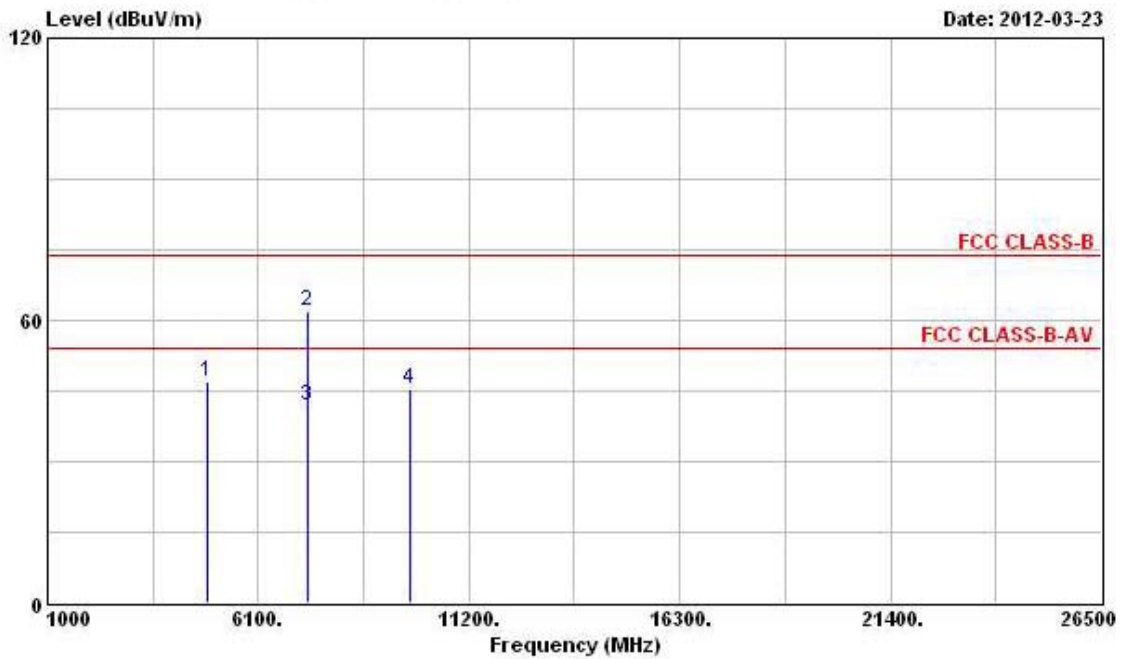

	Freq	Level	Over Limit	Limit Line	ReadAntenna Level	Antenna Factor	Cable Loss	Preamp Factor	Remark	Ant Pos	Table Pos
	MHz	dBuV/m	dB	dBuV/m	dBuV	dB/m	dB	dB		cm	deg
1	4874.000	47.05	-6.95	54.00	42.04	35.18	4.61	34.78	PK	---	---
2	7311.000	62.00	-12.00	74.00	54.54	36.92	5.64	35.10	Peak	---	---
3	7311.000	41.79	-12.21	54.00	34.33	36.92	5.64	35.10	Average	---	---
4	9748.000	45.44			35.85	38.71	6.36	35.48	Peak	---	---

Note: The item 4 is on un-restricted band, so the limit is -20dB for the field strength of the fundamental emissions (see section 3.6.7).

Final Test Date	Mar. 23, 2011	Test Site No.	03CH02-HY
Temperature	24.9°C	Humidity	53%
Test Engineer	Streak	Configuration	802.11n (20MHz) Ch. 11

Horizontal

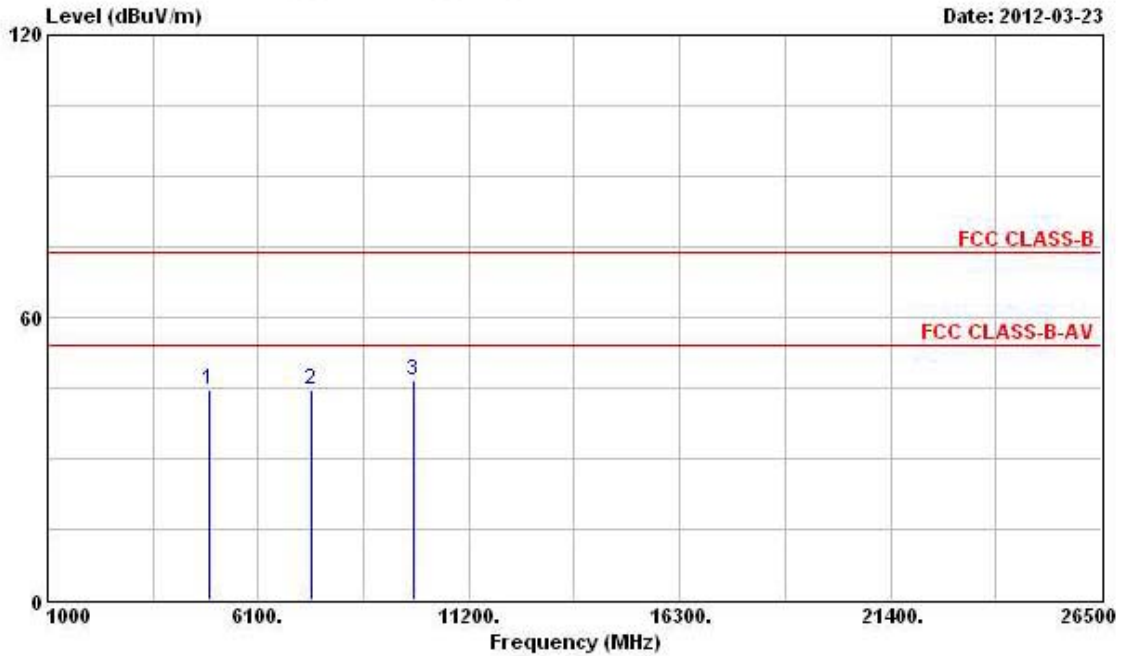

	Freq	Level	Over Limit	Limit Line	ReadAntenna Level	Antenna Factor	Cable Loss	Preamp Factor	Remark	Ant Pos	Table Pos
	MHz	dBuV/m	dB	dBuV/m	dBuV	dB/m	dB	dB		cm	deg
1	4924.000	44.62	-9.38	54.00	38.81	35.90	4.68	34.77	PK	---	---
2	7386.000	44.61	-9.39	54.00	36.20	37.88	5.65	35.12	PK	---	---
3	9848.000	46.62			36.12	39.61	6.38	35.49	Peak	---	---

Note: The item 3 is on un-restricted band, so the limit is -20dB for the field strength of the fundamental emissions (see section 3.6.7).

Vertical

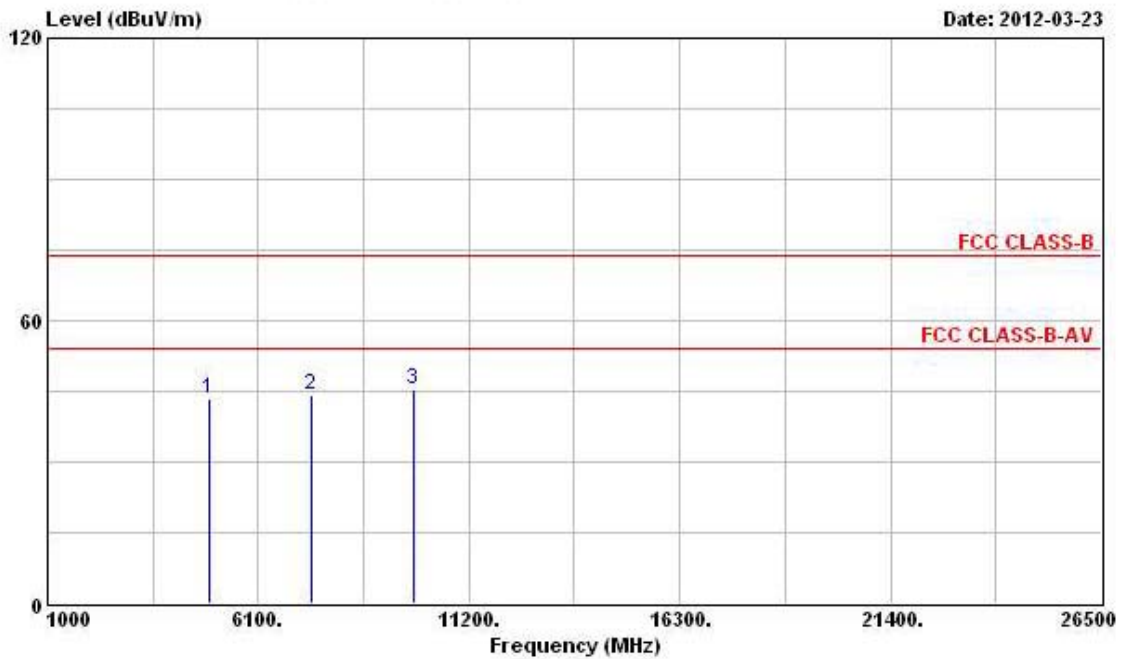

	Freq	Level	Over Limit	Limit Line	ReadAntenna Level	Antenna Factor	Cable Loss	Preamp Factor	Remark	Ant Pos	Table Pos
	MHz	dBuV/m	dB	dBuV/m	dBuV	dB/m	dB	dB		cm	deg
1	4924.000	43.60	-10.40	54.00	38.46	35.23	4.68	34.77	PK	---	---
2	7386.000	44.28	-9.72	54.00	36.79	36.96	5.65	35.12	PK	---	---
3	9848.000	45.42			35.72	38.81	6.38	35.49	Peak	---	---

Note: The item 3 is on un-restricted band, so the limit is -20dB for the field strength of the fundamental emissions (see section 3.6.7).

Final Test Date	Mar. 23, 2011	Test Site No.	03CH02-HY
Temperature	24.9°C	Humidity	53%
Test Engineer	Streak	Configuration	802.11n (40MHz) Ch. 3

Horizontal

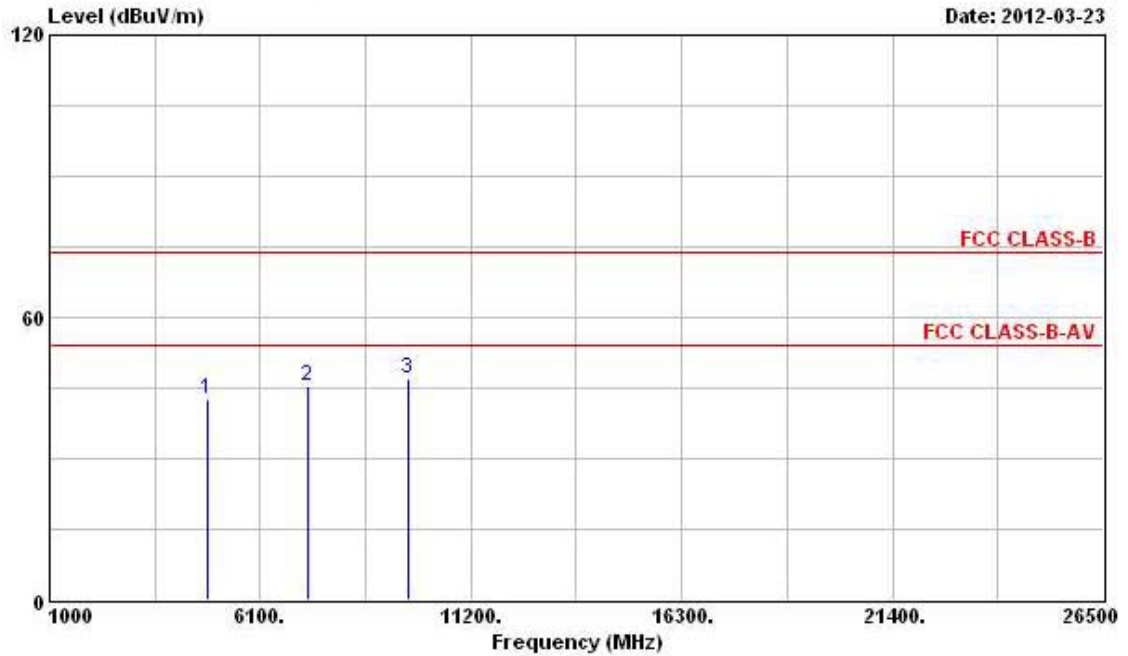

	Freq	Level	Over Limit	Limit Line	ReadAntenna Level	Antenna Factor	Cable Loss	Preamp Factor	Remark	Ant Pos	Table Pos
	MHz	dBuV/m	dB	dBuV/m	dBuV	dB/m	dB	dB		cm	deg
1	4844.000	42.71	-11.29	54.00	37.11	35.78	4.61	34.79	PK	---	---
2	7266.000	45.43	-8.57	54.00	37.03	37.86	5.63	35.09	PK	---	---
3	9688.000	46.91			36.61	39.43	6.35	35.48	Peak	---	---

Note: The item 3 is on un-restricted band, so the limit is -20dB for the field strength of the fundamental emissions (see section 3.6.7).

Vertical

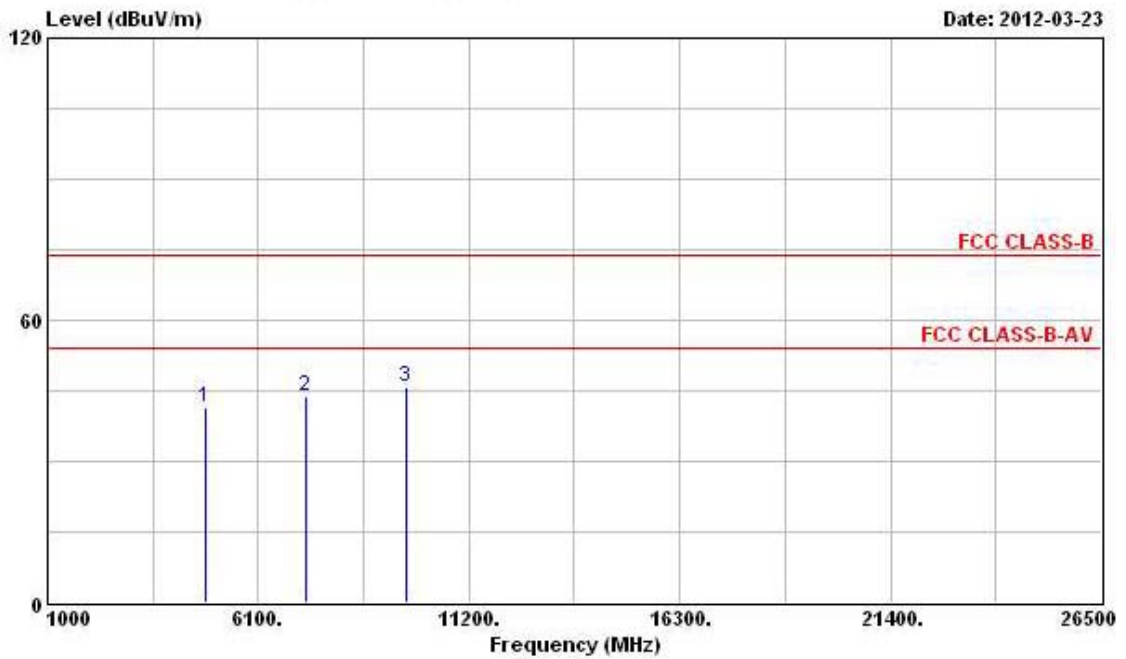

	Freq	Level	Over Limit	Limit Line	ReadAntenna Level	Antenna Factor	Cable Loss	Preamp Factor	Remark	Ant Pos	Table Pos
	MHz	dBuV/m	dB	dBuV/m	dBuV	dB/m	dB	dB		cm	deg
1	4844.000	41.56	-12.44	54.00	36.60	35.14	4.61	34.79	PK	---	---
2	7266.000	43.63	-10.37	54.00	36.18	36.91	5.63	35.09	PK	---	---
3	9688.000	45.67			36.17	38.63	6.35	35.48	Peak	---	---

Note: The item 3 is on un-restricted band, so the limit is -20dB for the field strength of the fundamental emissions (see section 3.6.7).

Final Test Date	Mar. 23, 2011	Test Site No.	03CH02-HY
Temperature	24.9°C	Humidity	53%
Test Engineer	Streak	Configuration	802.11n (40MHz) Ch. 6

Horizontal

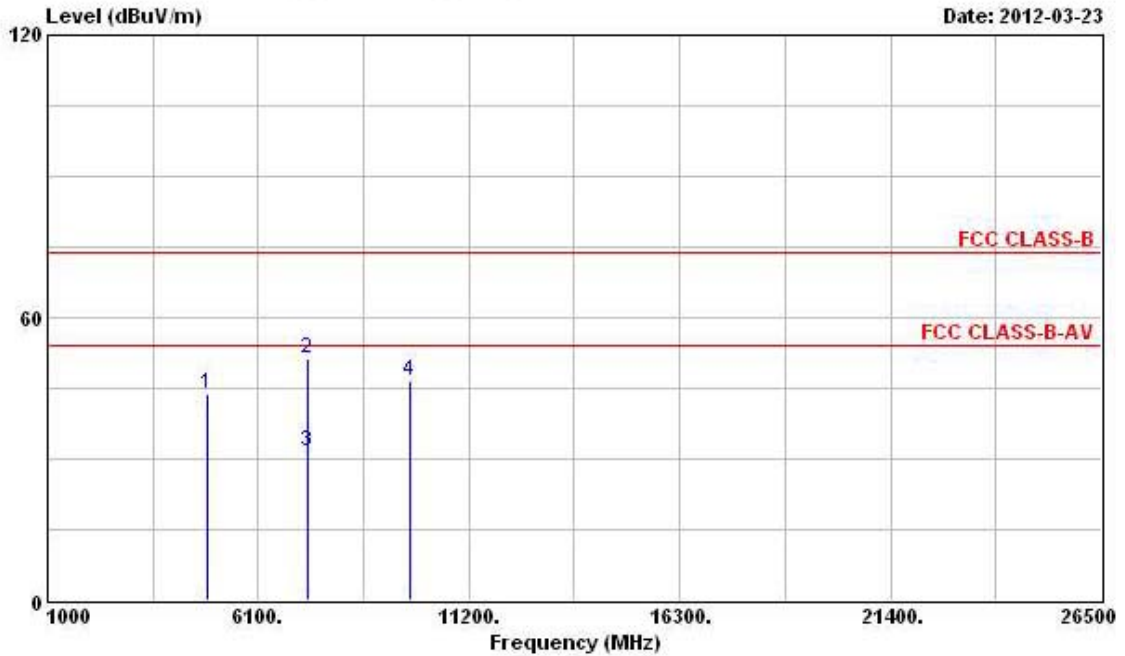

	Freq	Level	Over Limit	Limit Line	ReadAntenna Level	Antenna Factor	Cable Loss	Preamp Factor	Remark	Ant Pos	Table Pos
	MHz	dBuV/m	dB	dBuV/m	dBuV	dB/m	dB	dB		cm	deg
1	4874.000	43.82	-10.18	54.00	38.16	35.83	4.61	34.78	PK	---	---
2	7311.000	51.49	-22.51	74.00	43.09	37.86	5.64	35.10	Peak	---	---
3	7311.000	31.65	-22.35	54.00	23.25	37.86	5.64	35.10	Average	---	---
4	9748.000	46.42			36.03	39.51	6.36	35.48	Peak	---	---

Note: The item 4 is on un-restricted band, so the limit is -20dB for the field strength of the fundamental emissions (see section 3.6.7).

Vertical

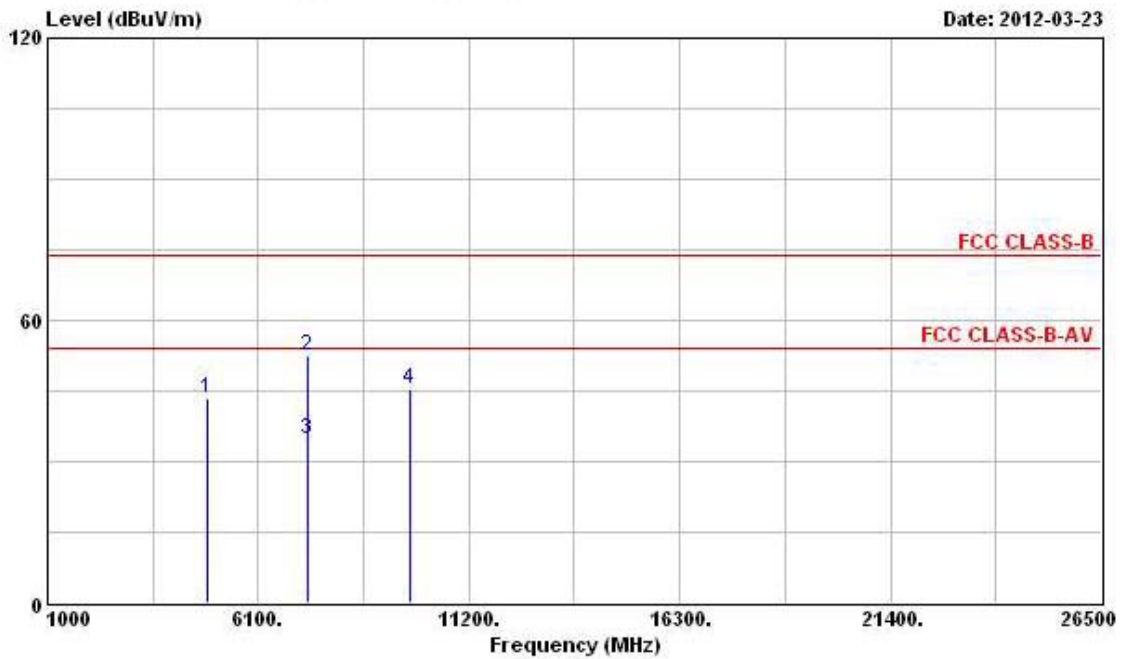

	Freq	Level	Over Limit	Limit Line	ReadAntenna Level	Antenna Factor	Cable Loss	Preamp Factor	Remark	Ant Pos	Table Pos
	MHz	dBuV/m	dB	dBuV/m	dBuV	dB/m	dB	dB		cm	deg
1	4874.000	43.39	-10.61	54.00	38.38	35.18	4.61	34.78	PK	---	---
2	7311.000	52.46	-21.54	74.00	45.00	36.92	5.64	35.10	Peak	---	---
3	7311.000	34.58	-19.42	54.00	27.12	36.92	5.64	35.10	Average	---	---
4	9748.000	45.44			35.85	38.71	6.36	35.48	Peak	---	---

Note: The item 4 is on un-restricted band, so the limit is -20dB for the field strength of the fundamental emissions (see section 3.6.7).

Final Test Date	Mar. 23, 2011	Test Site No.	03CH02-HY
Temperature	24.9°C	Humidity	53%
Test Engineer	Streak	Configuration	802.11n (40MHz) Ch. 9

Horizontal

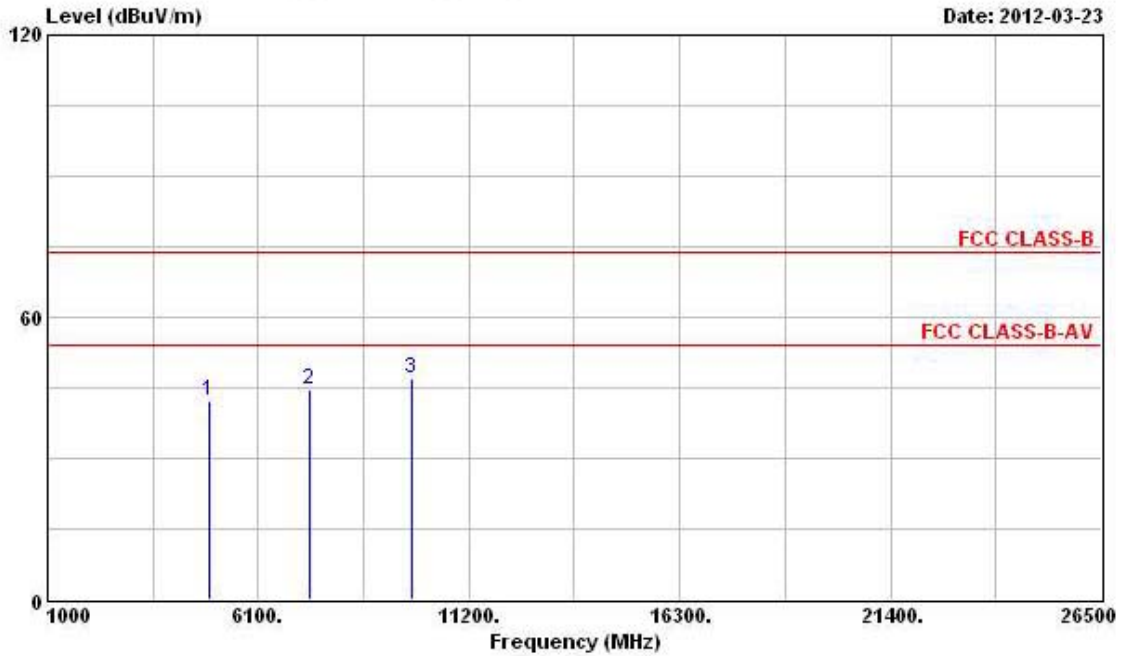

	Freq	Level	Over Limit	Limit Line	ReadAntenna Level	Antenna Factor	Cable Loss	Preamp Factor	Remark	Ant Pos	Table Pos
	MHz	dBuV/m	dB	dBuV/m	dBuV	dB/m	dB	dB		cm	deg
1	4904.000	42.16	-11.84	54.00	36.42	35.88	4.64	34.78	PK	---	---
2	7356.000	44.76	-9.24	54.00	36.36	37.87	5.64	35.11	PK	---	---
3	9808.000	46.87			36.41	39.57	6.37	35.48	Peak	---	---

Note: The item 3 is on un-restricted band, so the limit is -20dB for the field strength of the fundamental emissions (see section 3.6.7).

Vertical

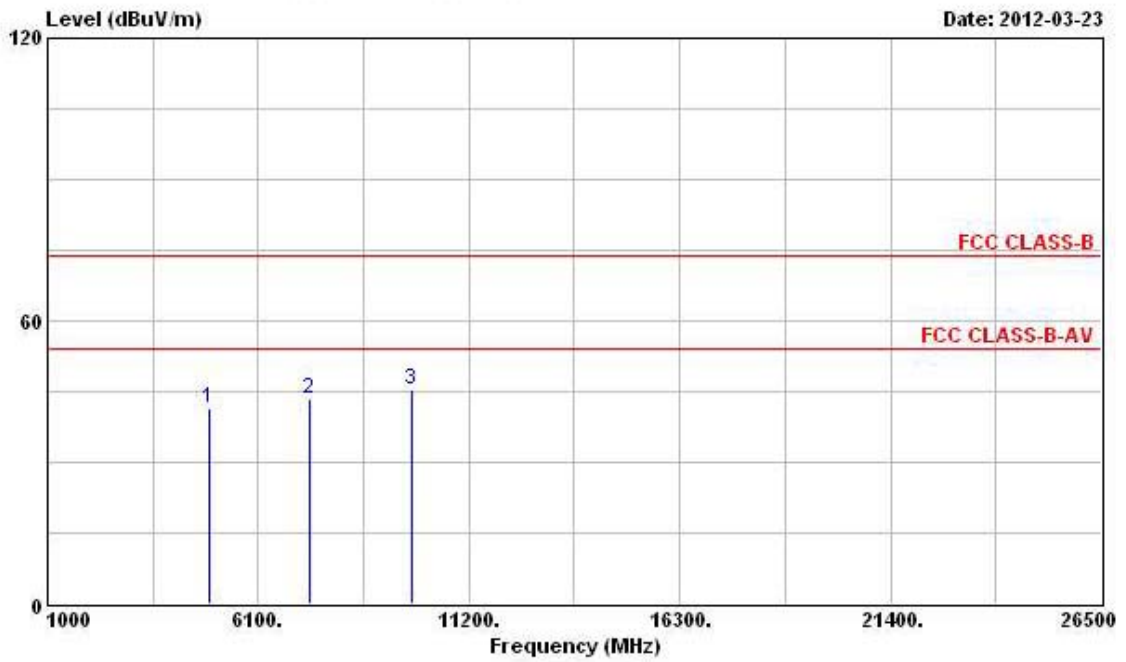

	Freq	Level	Over Limit	Limit Line	ReadAntenna Level	Antenna Factor	Cable Loss	Preamp Factor	Remark	Ant Pos	Table Pos
	MHz	dBuV/m	dB	dBuV/m	dBuV	dB/m	dB	dB		cm	deg
1	4904.000	41.47	-12.53	54.00	36.40	35.21	4.64	34.78	PK	---	---
2	7356.000	43.59	-10.41	54.00	36.12	36.94	5.64	35.11	PK	---	---
3	9808.000	45.37			35.71	38.77	6.37	35.48	Peak	---	---

Note: The item 3 is on un-restricted band, so the limit is -20dB for the field strength of the fundamental emissions (see section 3.6.7).

Emission level (dBuV/m) = 20 log Emission level (uV/m).

Corrected Reading: Antenna Factor + Cable Loss + Read Level - Preamp Factor = Level.

3.6 Band Edge and Fundamental Emissions Measurement

3.6.1 Limit

In any 100kHz bandwidth outside the frequency band in which the spread spectrum or digitally modulated intentional radiator is operating, the radio frequency power that is produced by the intentional radiator shall be at least 20dB below that in the 100kHz bandwidth within the band that contains the highest level of the desired power, based on either an RF conducted or a radiated measurement. If the transmitter measurement is based on the maximum conducted output power, the attenuation required under this paragraph shall be 30dB instead of 20dB. In addition, radiated emissions which fall in section 15.205(a) the restricted bands must also comply with the radiated emission limit specified in section 15.209(a).

Frequencies (MHz)	Field Strength (micorvolts/meter)	Measurement Distance (meters)
0.009~0.490	2400/F(kHz)	300
0.490~1.705	24000/F(kHz)	30
1.705~30.0	30	30
30~88	100	3
88~216	150	3
216~960	200	3
Above 960	500	3

3.6.2 Measuring Instruments and Setting

Please refer to section 4 of equipments list in this report. The following table is the setting of the spectrum analyzer.

Spectrum Parameter	Setting
Attenuation	Auto
Span Frequency	100 MHz
RB / VB (Emission in restricted band)	1MHz / 1MHz for Peak, 1 MHz / 10Hz for Average
RB / VB (Emission in non-restricted band)	1MHz / 1MHz for Peak

3.6.3 Test Procedures

1. The test procedure is the same as section 3.5.3; only the frequency range investigated is limited to 100MHz around band edges.
2. In case the emission is fail due to the used RB/VB is too wide, marker-delta method of FCC Public Notice DA00-705 will be followed.

3.6.4 Test Setup Layout

This test setup layout is the same as that shown in section 3.5.4.

3.6.5 Test Deviation

There is no deviation with the original standard.

3.6.6 EUT Operation during Test

The EUT was programmed to be in continuously transmitting mode.

3.6.7 Test Result of Band Edge and Fundamental Emissions

For Single Chain:

Final Test Date	Mar. 22, 2011	Test Site No.	03CH02-HY
Temperature	24.9°C	Humidity	53%
Test Engineer	Streak	Configuration	802.11b Ch. 1, 6, 11

Channel 1

	Freq	Level	Over Limit	Limit Line	ReadAntenna Level	Antenna Factor	Cable Loss	Preamp Factor	Remark	Ant Pos	Table Pos
	MHz	dBuV/m	dB	dBuV/m	dBuV	dB/m	dB	dB		cm	deg
1	2390.000	50.23	-3.77	54.00	15.18	32.03	3.02	0.00	Average	---	---
2 @	2412.980	103.17			68.06	32.09	3.02	0.00	Average	---	---
1	2389.610	63.36	-10.64	74.00	28.31	32.03	3.02	0.00	Peak	---	---
2 @	2413.170	112.94			77.83	32.09	3.02	0.00	Peak	---	---

The item 2 is Fundamental Emissions.

Channel 6

	Freq	Level	Over Limit	Limit Line	ReadAntenna Level	Antenna Factor	Cable Loss	Preamp Factor	Remark	Ant Pos	Table Pos
	MHz	dBuV/m	dB	dBuV/m	dBuV	dB/m	dB	dB		cm	deg
1 @	2438.820	103.22			67.96	32.21	3.05	0.00	Average	---	---
1 @	2436.730	113.31			78.05	32.21	3.05	0.00	Peak	---	---

The item 1 is Fundamental Emissions.

Channel 11

	Freq	Level	Over Limit	Limit Line	ReadAntenna Level	Antenna Factor	Cable Loss	Preamp Factor	Remark	Ant Pos	Table Pos
	MHz	dBuV/m	dB	dBuV/m	dBuV	dB/m	dB	dB		cm	deg
1 @	2461.620	104.23			68.90	32.28	3.05	0.00	Average	---	---
2 @	2483.500	51.10	-2.90	54.00	15.68	32.34	3.08	0.00	Average	---	---
1 @	2461.810	114.14			78.81	32.28	3.05	0.00	Peak	---	---
2	2483.660	65.82	-8.18	74.00	30.40	32.34	3.08	0.00	Peak	---	---

The item 1 is Fundamental Emissions.

Note:

Emission level (dBuV/m) = 20 log Emission level (uV/m).

Corrected Reading: Antenna Factor + Cable Loss + Read Level - Preamp Factor = Level.

Final Test Date	Mar. 22, 2011	Test Site No.	03CH02-HY
Temperature	24.9°C	Humidity	53%
Test Engineer	Streak	Configuration	802.11g Ch.1, 6, 11

Channel 1

	Freq	Level	Over Limit	Limit Line	Read Level	Antenna Factor	Cable Loss	Preamp Factor	Remark	Ant Pos	Table Pos
	MHz	dBuV/m	dB	dBuV/m	dBuV	dB/m	dB	dB		cm	deg
1 @	2390.000	52.89	-1.11	54.00	17.84	32.03	3.02	0.00	Average	---	---
2 @	2412.980	97.62			62.51	32.09	3.02	0.00	Average	---	---
1	2390.000	68.10	-5.90	74.00	33.05	32.03	3.02	0.00	Peak	---	---
2 @	2411.650	109.48			74.37	32.09	3.02	0.00	Peak	---	---

The item 2 is Fundamental Emissions.

Channel 6

	Freq	Level	Over Limit	Limit Line	Read Level	Antenna Factor	Cable Loss	Preamp Factor	Remark	Ant Pos	Table Pos
	MHz	dBuV/m	dB	dBuV/m	dBuV	dB/m	dB	dB		cm	deg
1 @	2438.060	102.62			67.36	32.21	3.05	0.00	Average	---	---
1 @	2436.730	115.18			79.92	32.21	3.05	0.00	Peak	---	---

The item 1 is Fundamental Emissions.

Channel 11

	Freq	Level	Over Limit	Limit Line	Read Level	Antenna Factor	Cable Loss	Preamp Factor	Remark	Ant Pos	Table Pos
	MHz	dBuV/m	dB	dBuV/m	dBuV	dB/m	dB	dB		cm	deg
1 @	2463.140	98.18			62.82	32.28	3.08	0.00	Average	---	---
2 @	2492.210	52.85	-1.15	54.00	17.37	32.40	3.08	0.00	Average	---	---
1 @	2462.380	109.86			74.53	32.28	3.05	0.00	Peak	---	---
2 @	2483.660	71.37	-2.63	74.00	35.95	32.34	3.08	0.00	Peak	---	---

The item 1 is Fundamental Emissions.

Note:

Emission level (dBuV/m) = 20 log Emission level (uV/m).

Corrected Reading: Antenna Factor + Cable Loss + Read Level - Preamp Factor = Level.

Final Test Date	Mar. 22, 2011	Test Site No.	03CH02-HY
Temperature	24.9°C	Humidity	53%
Test Engineer	Streak	Configuration	802.11n (20MHz) Ch.1, 6, 11

Channel 1

	Freq	Level	Over Limit	Limit Line	ReadAntenna Level	Antenna Factor	Cable Loss	Preamp Factor	Remark	Ant Pos	Table Pos
	MHz	dBuV/m	dB	dBuV/m	dBuV	dB/m	dB	dB		cm	deg
1 @	2390.000	52.90	-1.10	54.00	17.85	32.03	3.02	0.00	Average	---	---
2 @	2412.980	96.80			61.69	32.09	3.02	0.00	Average	---	---
1 @	2390.000	71.57	-2.43	74.00	36.52	32.03	3.02	0.00	Peak	---	---
2 @	2412.220	108.15			73.04	32.09	3.02	0.00	Peak	---	---

The item 2 is Fundamental Emissions.

Channel 6

	Freq	Level	Over Limit	Limit Line	ReadAntenna Level	Antenna Factor	Cable Loss	Preamp Factor	Remark	Ant Pos	Table Pos
	MHz	dBuV/m	dB	dBuV/m	dBuV	dB/m	dB	dB		cm	deg
1 @	2437.490	101.37			66.11	32.21	3.05	0.00	Average	---	---
1 @	2437.490	113.15			77.89	32.21	3.05	0.00	Peak	---	---

The item 1 is Fundamental Emissions.

Channel 11

	Freq	Level	Over Limit	Limit Line	ReadAntenna Level	Antenna Factor	Cable Loss	Preamp Factor	Remark	Ant Pos	Table Pos
	MHz	dBuV/m	dB	dBuV/m	dBuV	dB/m	dB	dB		cm	deg
1 @	2461.050	96.79			61.46	32.28	3.05	0.00	Average	---	---
2 @	2484.420	53.00	-1.00	54.00	17.58	32.34	3.08	0.00	Average	---	---
1 @	2462.380	108.28			72.95	32.28	3.05	0.00	Peak	---	---
2 @	2483.500	71.70	-2.30	74.00	36.28	32.34	3.08	0.00	Peak	---	---

The item 1 is Fundamental Emissions.

Note:

Emission level (dBuV/m) = 20 log Emission level (uV/m).

Corrected Reading: Antenna Factor + Cable Loss + Read Level - Preamp Factor = Level.

Final Test Date	Mar. 22, 2011	Test Site No.	03CH02-HY
Temperature	24.9°C	Humidity	53%
Test Engineer	Streak	Configuration	802.11n (40MHz) Ch.3, 6, 9

Channel 3

	Freq	Level	Over Limit	Limit Line	ReadAntenna Level	Antenna Factor	Cable Loss	Preamp Factor	Remark	Ant Pos	Table Pos
	MHz	dBuV/m	dB	dBuV/m	dBuV	dB/m	dB	dB		cm	deg
1 @	2387.140	52.37	-1.63	54.00	17.32	32.03	3.02	0.00	Average	---	---
2 @	2423.810	90.97			55.77	32.15	3.05	0.00	Average	---	---
1	2388.090	69.01	-4.99	74.00	33.96	32.03	3.02	0.00	Peak	---	---
2 @	2424.380	103.53			68.33	32.15	3.05	0.00	Peak	---	---

The item 2 is Fundamental Emissions.

Channel 6

	Freq	Level	Over Limit	Limit Line	ReadAntenna Level	Antenna Factor	Cable Loss	Preamp Factor	Remark	Ant Pos	Table Pos
	MHz	dBuV/m	dB	dBuV/m	dBuV	dB/m	dB	dB		cm	deg
1 @	2438.820	96.31			61.05	32.21	3.05	0.00	Average	---	---
1 @	2439.010	109.00			73.74	32.21	3.05	0.00	Peak	---	---

The item 1 is Fundamental Emissions.

Channel 9

	Freq	Level	Over Limit	Limit Line	ReadAntenna Level	Antenna Factor	Cable Loss	Preamp Factor	Remark	Ant Pos	Table Pos
	MHz	dBuV/m	dB	dBuV/m	dBuV	dB/m	dB	dB		cm	deg
1 @	2439.770	91.14			55.88	32.21	3.05	0.00	Average	---	---
2 @	2489.740	52.92	-1.08	54.00	17.44	32.40	3.08	0.00	Average	---	---
1 @	2439.010	103.88			68.62	32.21	3.05	0.00	Peak	---	---
2	2485.180	69.20	-4.80	74.00	33.78	32.34	3.08	0.00	Peak	---	---

The item 1 is Fundamental Emissions.

Note:

Emission level (dBuV/m) = 20 log Emission level (uV/m).

Corrected Reading: Antenna Factor + Cable Loss + Read Level - Preamp Factor = Level.

For Two Chains:

Final Test Date	Mar. 22, 2011	Test Site No.	03CH02-HY
Temperature	24.9°C	Humidity	53%
Test Engineer	Streak	Configuration	802.11n (20MHz) Ch.1, 6, 11

Channel 1

Freq	Level	Over Limit	Limit Line	ReadAntenna Level	Antenna Factor	Cable Loss	Preamp Factor	Remark	Ant Pos	Table Pos
MHz	dBuV/m	dB	dBuV/m	dBuV	dB/m	dB	dB		cm	deg
1 @ 2390.000	52.25	-1.75	54.00	17.20	32.03	3.02	0.00	Average	---	---
2 @ 2412.410	93.72			58.61	32.09	3.02	0.00	Average	---	---
1 @ 2390.000	68.61	-5.39	74.00	33.56	32.03	3.02	0.00	Peak	---	---
2 @ 2412.980	107.07			71.96	32.09	3.02	0.00	Peak	---	---

The item 2 is Fundamental Emissions.

Channel 6

Freq	Level	Over Limit	Limit Line	ReadAntenna Level	Antenna Factor	Cable Loss	Preamp Factor	Remark	Ant Pos	Table Pos
MHz	dBuV/m	dB	dBuV/m	dBuV	dB/m	dB	dB		cm	deg
1 @ 2436.540	99.12			63.86	32.21	3.05	0.00	Average	---	---
1 @ 2438.060	112.61			77.35	32.21	3.05	0.00	Peak	---	---

The item 1 is Fundamental Emissions.

Channel 11

Freq	Level	Over Limit	Limit Line	ReadAntenna Level	Antenna Factor	Cable Loss	Preamp Factor	Remark	Ant Pos	Table Pos
MHz	dBuV/m	dB	dBuV/m	dBuV	dB/m	dB	dB		cm	deg
1 @ 2461.050	95.00			59.67	32.28	3.05	0.00	Average	---	---
2 @ 2483.500	52.98	-1.02	54.00	17.56	32.34	3.08	0.00	Average	---	---
1 @ 2463.140	108.11			72.75	32.28	3.08	0.00	Peak	---	---
2 @ 2483.850	67.80	-6.20	74.00	32.38	32.34	3.08	0.00	Peak	---	---

The item 1 is Fundamental Emissions.

Note:

Emission level (dBuV/m) = 20 log Emission level (uV/m).

Corrected Reading: Antenna Factor + Cable Loss + Read Level - Preamp Factor = Level.

Final Test Date	Mar. 22, 2011	Test Site No.	03CH02-HY
Temperature	24.9°C	Humidity	53%
Test Engineer	Streak	Configuration	802.11n (40MHz) Ch.3, 6, 9

Channel 3

Freq	Level	Over Limit	Limit Line	Read Level	Antenna Factor	Cable Loss	Preamp Factor	Remark	Ant Pos	Table Pos
MHz	dBuV/m	dB	dBuV/m	dBuV	dB/m	dB	dB		cm	deg
1 @ 2388.660	52.94	-1.06	54.00	17.89	32.03	3.02	0.00	Average	---	---
2 @ 2424.380	88.38			53.18	32.15	3.05	0.00	Average	---	---
1 @ 2385.050	69.29	-4.71	74.00	34.30	31.97	3.02	0.00	Peak	---	---
2 @ 2423.810	104.90			69.70	32.15	3.05	0.00	Peak	---	---

The item 2 is Fundamental Emissions.

Channel 6

Freq	Level	Over Limit	Limit Line	Read Level	Antenna Factor	Cable Loss	Preamp Factor	Remark	Ant Pos	Table Pos
MHz	dBuV/m	dB	dBuV/m	dBuV	dB/m	dB	dB		cm	deg
1 @ 2439.010	91.83			56.57	32.21	3.05	0.00	Average	---	---
1 @ 2439.010	107.97			72.71	32.21	3.05	0.00	Peak	---	---

The item 1 is Fundamental Emissions.

Channel 9

Freq	Level	Over Limit	Limit Line	Read Level	Antenna Factor	Cable Loss	Preamp Factor	Remark	Ant Pos	Table Pos
MHz	dBuV/m	dB	dBuV/m	dBuV	dB/m	dB	dB		cm	deg
1 @ 2454.020	88.79			53.46	32.28	3.05	0.00	Average	---	---
2 @ 2485.940	52.89	-1.11	54.00	17.47	32.34	3.08	0.00	Average	---	---
1 @ 2454.020	104.97			69.64	32.28	3.05	0.00	Peak	---	---
2 @ 2484.420	68.57	-5.43	74.00	33.15	32.34	3.08	0.00	Peak	---	---

The item 1 is Fundamental Emissions.

Note:

Emission level (dBuV/m) = 20 log Emission level (uV/m).

Corrected Reading: Antenna Factor + Cable Loss + Read Level - Preamp Factor = Level.

For Emission not in Restricted Band

Final Test Date	Apr. 08, 2012	Test Site No.	TH01-HY
Temperature	23°C	Humidity	33%
Test Engineer	Shiming	Configurations	802.11b/g/n

For Single Chain:

Low Band Edge Plot on Configuration IEEE 802.11b 2412 MHz Port 1

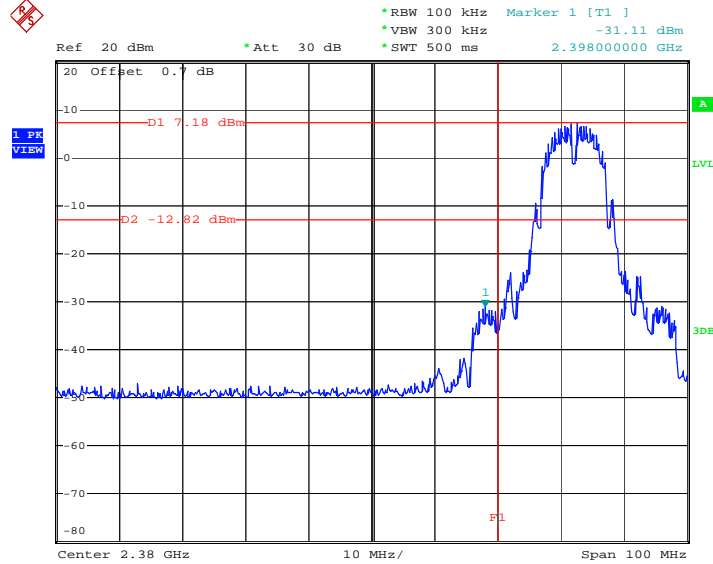

Date: 8.APR.2012 02:06:41

High Band Edge Plot on Configuration IEEE 802.11b 2462 MHz Port 1

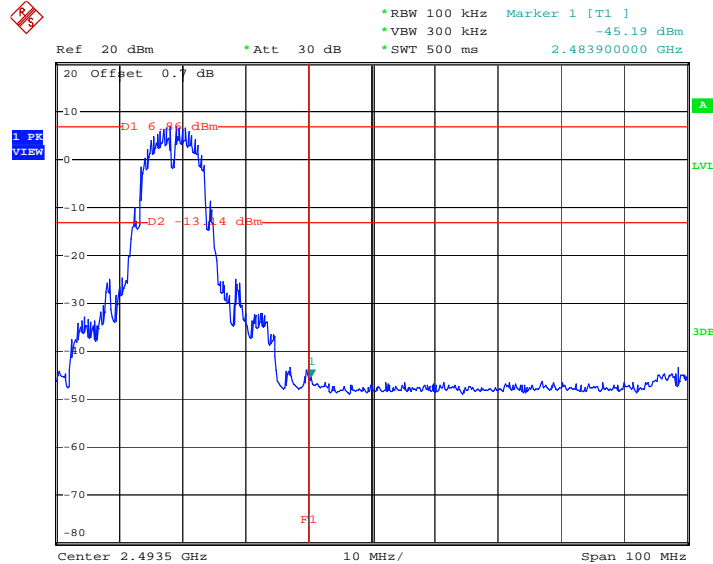

Date: 8.APR.2012 02:17:42

Low Band Edge Plot on Configuration IEEE 802.11g 2412 MHz Port 1

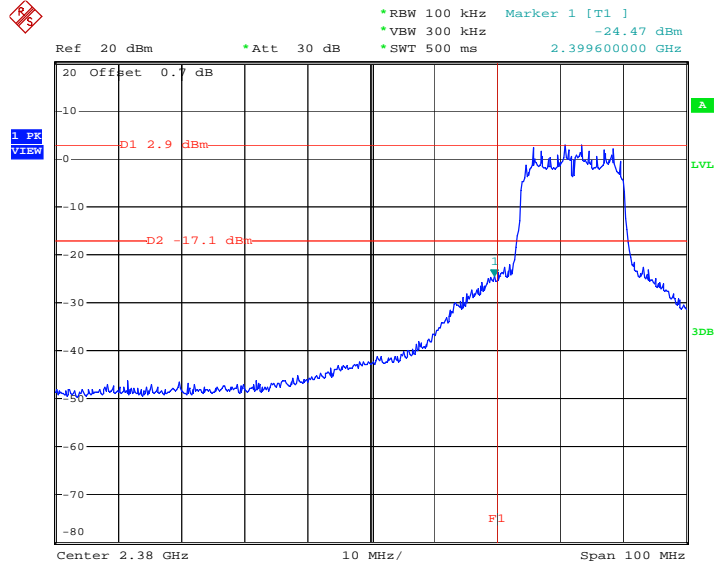

Date: 7.APR.2012 03:15:58

High Band Edge Plot on Configuration IEEE 802.11g 2462 MHz Port 1

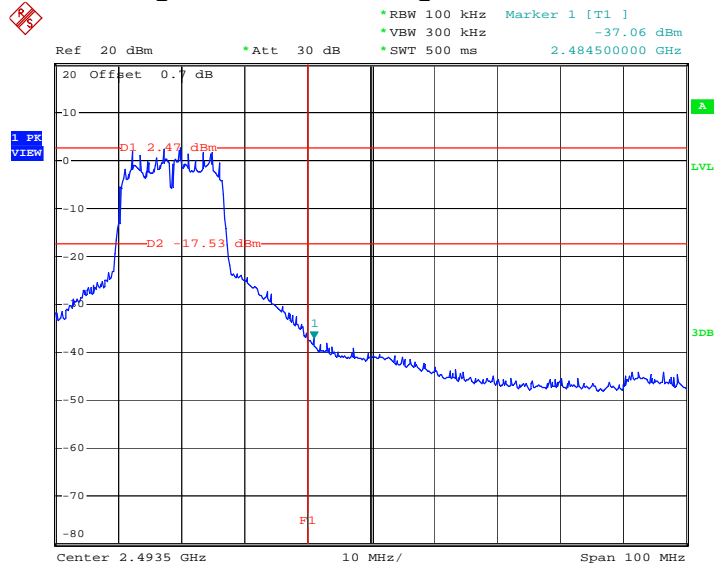

Date: 7.APR.2012 03:23:16

Low Band Edge Plot on Configuration IEEE 802.11n (20MHz) 2412 MHz Port 1

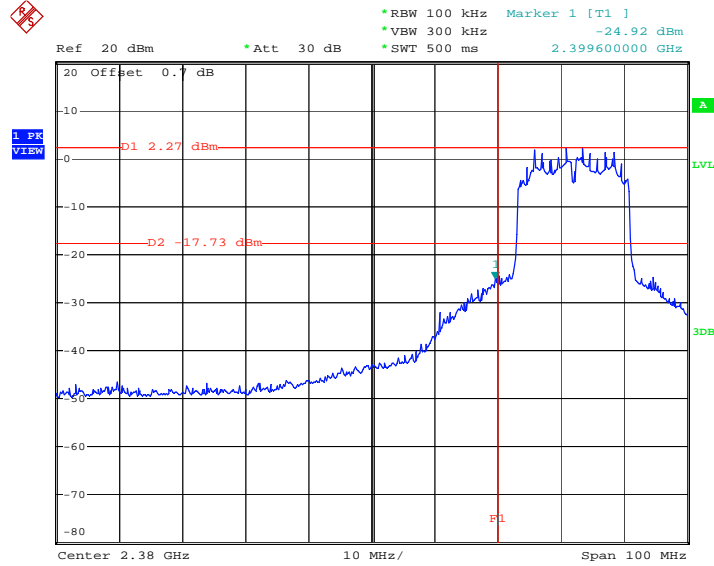

Date: 7.APR.2012 03:29:38

High Band Edge Plot on Configuration IEEE 802.11n (20MHz) 2462 MHz Port 1

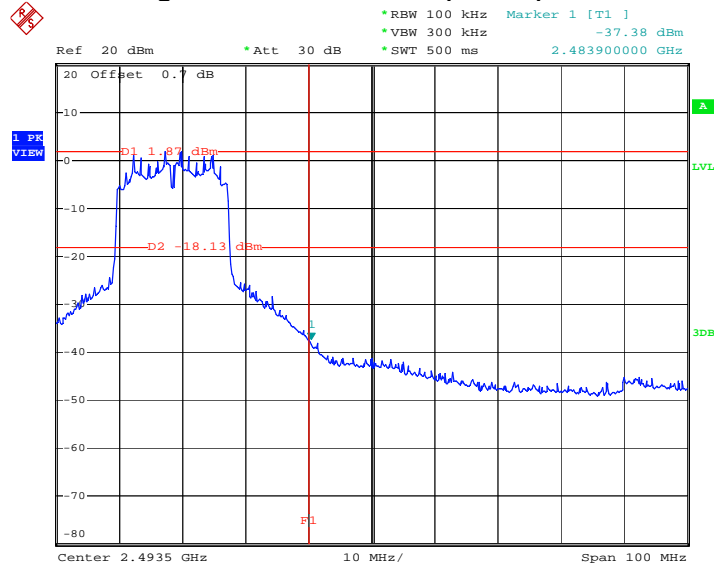

Date: 7.APR.2012 03:36:59

Low Band Edge Plot on Configuration IEEE 802.11n (40MHz) 2422 MHz Port 1

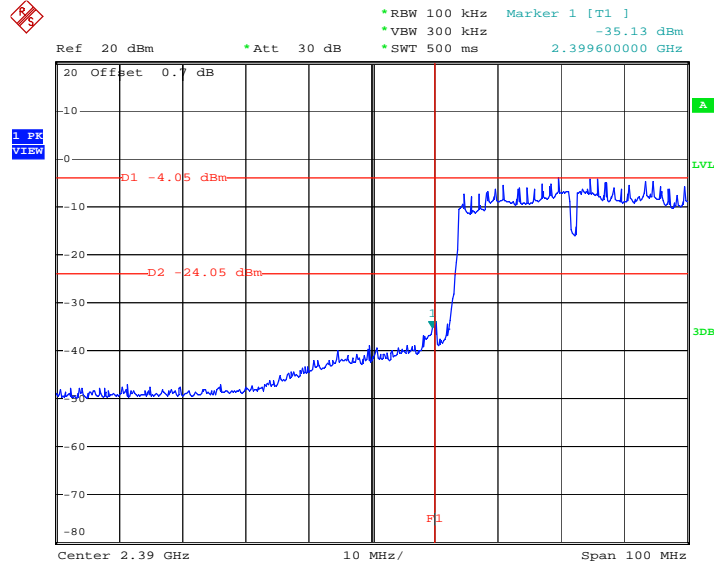

Date: 7.APR.2012 03:47:10

High Band Edge Plot on Configuration IEEE 802.11n (40MHz) 2452 MHz Port 1

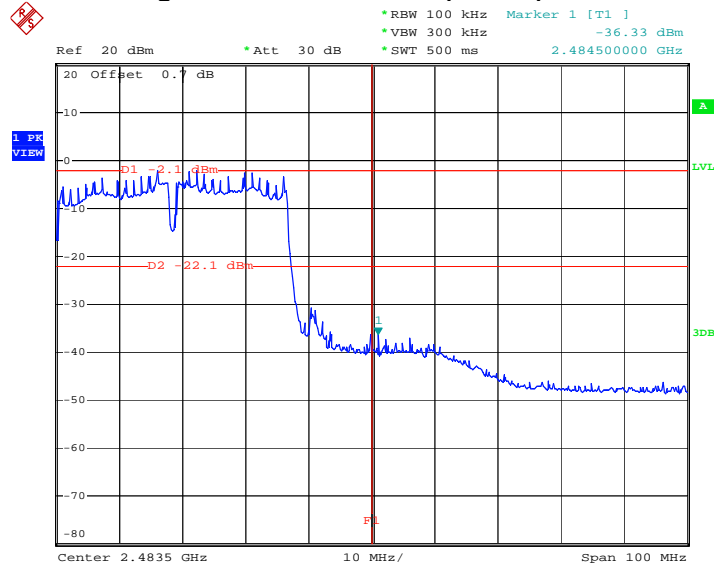

Date: 7.APR.2012 03:57:22

For Two Chains
Low Band Edge Plot on Configuration IEEE 802.11n (20MHz) 2412 MHz Port 1

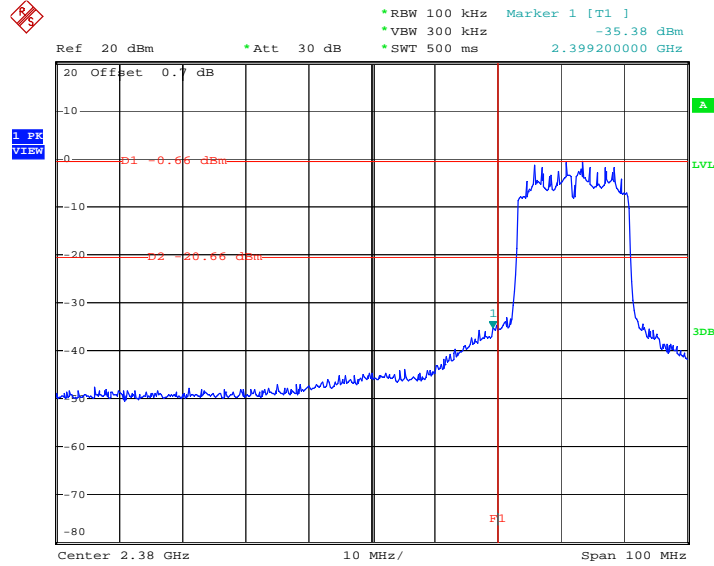

Date: 7.APR.2012 05:05:21

High Band Edge Plot on Configuration IEEE 802.11n (20MHz) 2462 MHz Port 1

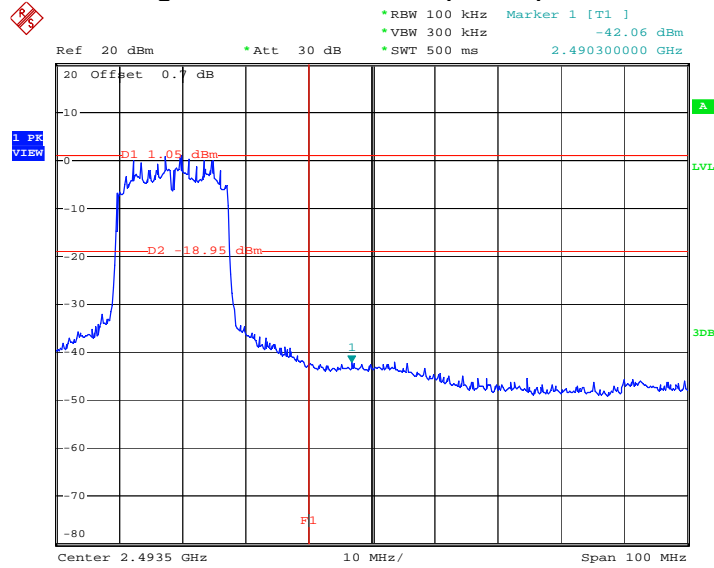

Date: 7.APR.2012 05:14:47

Low Band Edge Plot on Configuration IEEE 802.11n (20MHz) 2412 MHz Port 2

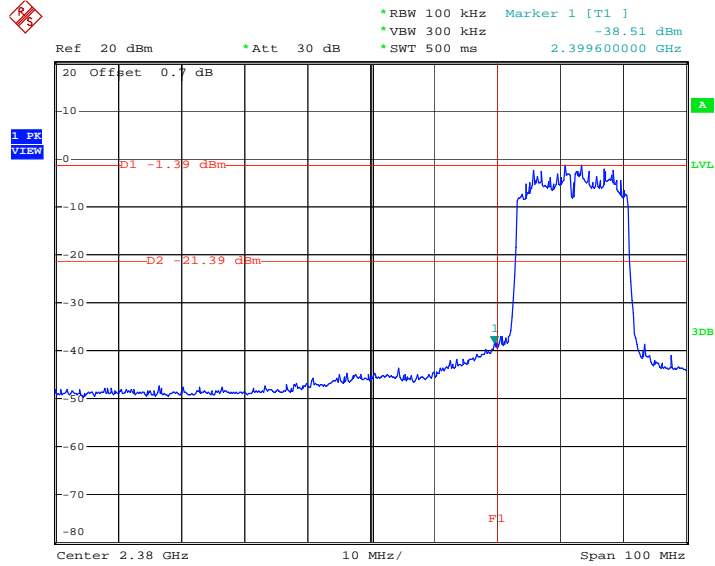

Date: 7.APR.2012 05:22:16

High Band Edge Plot on Configuration IEEE 802.11n (20MHz) 2462 MHz Port 2

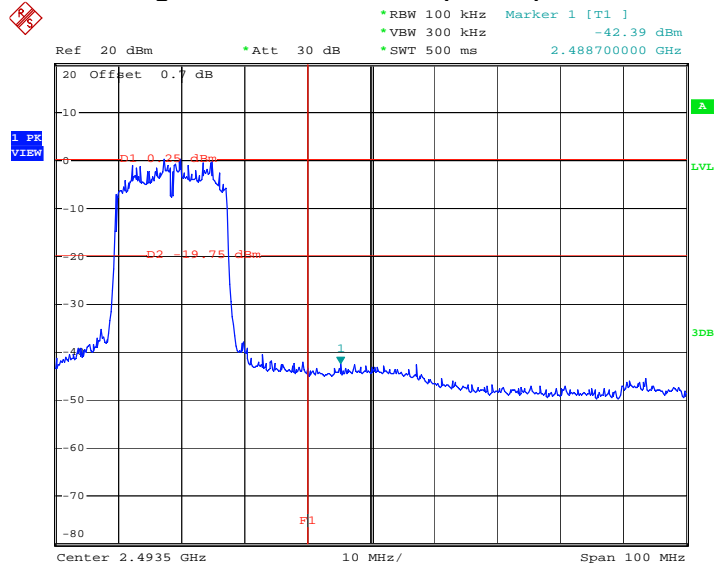

Date: 7.APR.2012 05:32:39

Low Band Edge Plot on Configuration IEEE 802.11n (40MHz) 2422 MHz Port 1

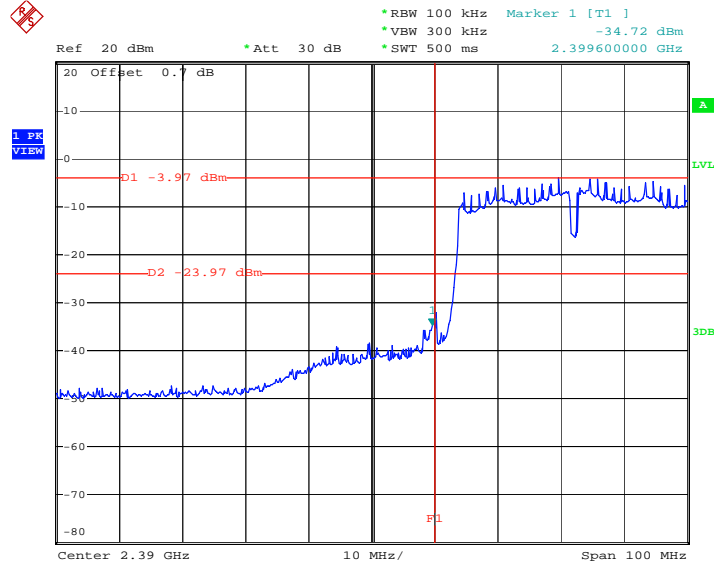

Date: 7.APR.2012 04:16:40

High Band Edge Plot on Configuration IEEE 802.11n (40MHz) 2452 MHz Port 1

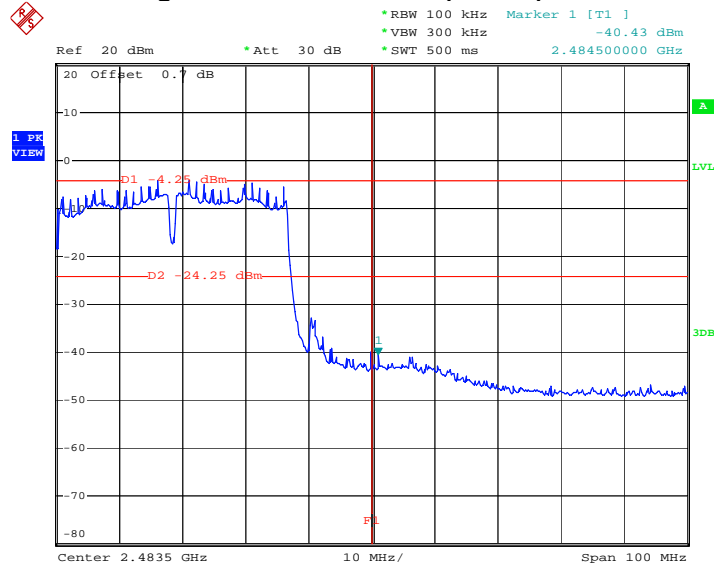

Date: 7.APR.2012 04:27:41

Low Band Edge Plot on Configuration IEEE 802.11n (40MHz) 2422 MHz Port 2

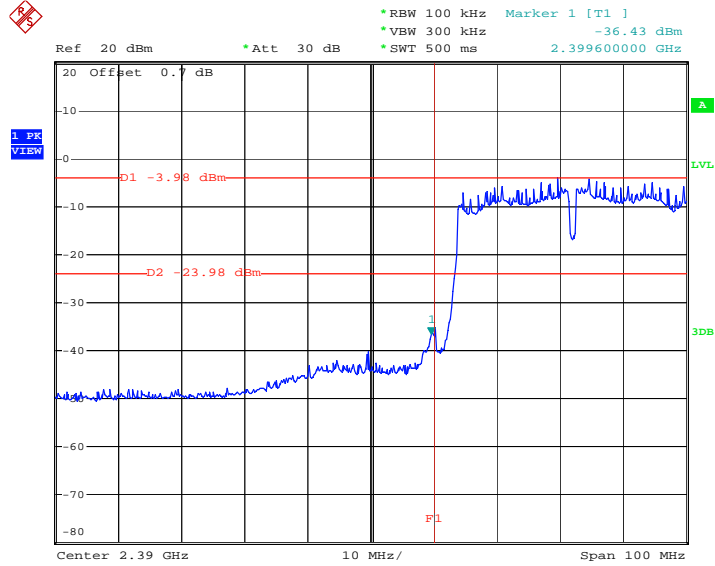

Date: 7.APR.2012 04:33:59

High Band Edge Plot on Configuration IEEE 802.11n (40MHz) 2452 MHz Port 2

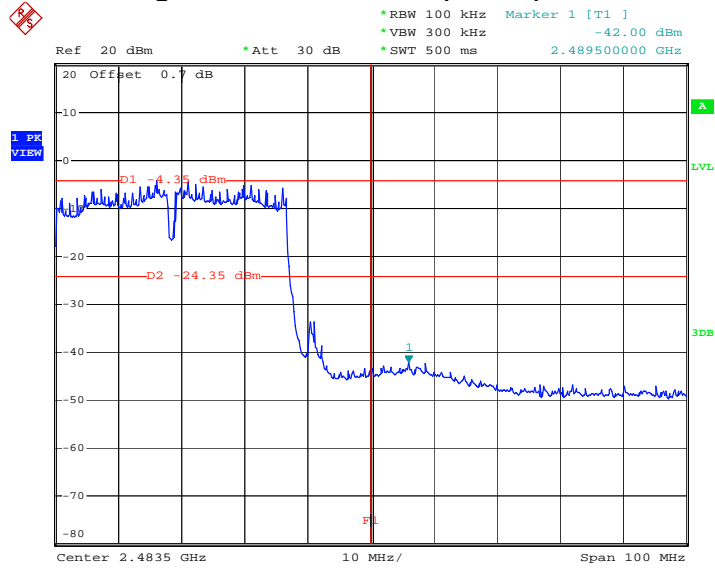

Date: 7.APR.2012 04:43:30

3.7 Antenna Requirements

3.7.1 Limit

Except for special regulations, the Low-power Radio-frequency Devices must not be equipped with any jacket for installing an antenna with extension cable. An intentional radiator shall be designed to ensure that no antenna other than that furnished by the responsible party shall be used with the device. The use of a permanently attached antenna or of an antenna that uses a unique coupling to the intentional radiator shall be considered sufficient to comply with the provisions of this Section. The manufacturer may design the unit so that the user can replace a broken antenna, but the use of a standard antenna jack or electrical connector is prohibited.

3.7.2 Antenna Connector Construction

Please refer to section 2.3 in this test report; antenna connector complied with the requirements.

4 LIST OF MEASURING EQUIPMENTS

Instrument	Manufacturer	Model No.	Serial No.	Characteristics	Calibration Date	Remark
EMC Receiver	R&S	ESCS 30	100174	9 kHz ~ 2.75 GHz	Mar. 23, 2012	Conduction (CO04-HY)
LISN	SCHWARZBECK MESS-ELEKTRONIK	NSLK 8127	8127-477	9kHz – 30MHz	Feb. 08, 2012	Conduction (CO04-HY)
LISN (Support Unit)	EMCO	3810/2NM	9703-1839	9 kHz ~ 30 MHz	May 04, 2011	Conduction (CO04-HY)
RF Cable-CON	HUBER+SUHNER	RG213/U	CB049	9 kHz ~ 30 MHz	Apr. 21, 2011	Conduction (CO04-HY)
ISN	SCHAFFNER	ISN T400	21653	9 kHz ~30 MHz	Jun. 04, 2011	Conduction (CO04-HY)
EMI Filter	LINDGREN	LRE-2030	2651	< 450 Hz	N/A	Conduction (CO04-HY)

Note: Calibration Interval of instruments listed above is one year.

Instrument	Manufacturer	Model No.	Serial No.	Characteristics	Calibration Date	Remark
Spectrum Analyzer	R&S	FSP 40	100305	9 KHz ~ 40 GHz	Feb. 21, 2012	Conducted (TH01-HY)
DC Power Source	G.W.	GPC-6030D	C671845	DC 1V ~ 60V	Jun. 03, 2011	Conducted (TH01-HY)
Temp. and Humidity Chamber	Giant Force	GTH-225-20-SP-SD	MAA1112-007	-20~100℃	Dec. 07, 2011	Conducted (TH01-HY)
Signal Generator	R&S	SMR40	100116	10 MHz ~ 40 GHz	Jun. 07, 2011	Conducted (TH01-HY)
Power Sensor	Anritsu	MA2411B	1027452	300 MHz ~ 40 GHz	Jun. 16, 2011	Conducted (TH01-HY)
Power Meter	Anritsu	ML2495A	1124009	300 MHz ~ 40 GHz	Jun. 20, 2011	Conducted (TH01-HY)
RF Cable-1m	Jye Bao	RG142	CB034-1m	20 MHz ~ 7 GHz	Dec. 03, 2011	Conducted (TH01-HY)
RF Cable-2m	Jye Bao	RG142	CB035-2m	20 MHz ~ 1 GHz	Dec. 03, 2011	Conducted (TH01-HY)

Note: Calibration Interval of instruments listed above is one year.

Instrument	Manufacturer	Model No.	Serial No.	Characteristics	Calibration Date	Remark
AC Power Source	HPC	HPA-500W	HPA-9100024	AC 0 ~ 300V	Jun. 09, 2011*	Conducted (TH01-HY)

Note: Calibration Interval of instruments listed above is two year.

Instrument	Manufacturer	Model No.	Serial No.	Characteristics	Calibration Date	Remark
Spectrum Analyzer	R&S	FSP40	100593	9 kHz ~ 40 GHz	Aug. 08, 2011	Radiation (03CH02-HY)
3m Semi Anechoic Chamber	SIDT FRANKONIA	SAC-3M	03CH02-HY	30 MHz ~ 1 GHz 3m	May 11, 2011	Radiation (03CH02-HY)
Amplifier	Agilent	8447D	2944A11146	100 kHz ~ 1.3 GHz	Jul. 25, 2011	Radiation (03CH02-HY)
Amplifier	Agilent	8449B	3008A02373	1 GHz ~ 26.5 GHz	Jul. 25, 2011	Radiation (03CH02-HY)
Horn Antenna	ETS-LINDGREN	3117	00091920	1 GHz ~ 18 GHz	Nov. 15, 2011	Radiation (03CH02-HY)
RF Cable-R03m	Jye Bao	RG142	CB021	30 MHz ~ 1 GHz	Nov. 11, 2011	Radiation (03CH02-HY)
RF Cable-high	SUHNER	SUCOFLEX 106	03CH03-HY	1 GHz ~ 40 GHz	Jan. 18, 2012	Radiation (03CH02-HY)
Bilog Antenna	SCHAFFNER	CBL61128	2723	30 MHz ~ 2 GHz	Oct. 22, 2011	Radiation (03CH02-HY)
Turn Table	HD	DS 420	420/649/00	0 - 360 degree	N/A	Radiation (03CH02-HY)
Antenna Mast	HD	MA 240	240/559/00	1 m - 4 m	N/A	Radiation (03CH02-HY)

Note: Calibration Interval of instruments listed above is one year.

Instrument	Manufacturer	Model No.	Serial No.	Characteristics	Calibration Date	Remark
Loop Antenna	R&S	HFH2-Z2	860004/001	9 kHz - 30 MHz	Jul. 29, 2010*	Radiation (03CH02-HY)

Note: Calibration Interval of instruments listed above is two year.

5 TEST LOCATION

SHIJR	ADD : 6Fl., No. 106, Sec. 1, Shintai 5th Rd., Shijr City, Taipei 221, Taiwan, R.O.C. TEL : 886-2-2696-2468 FAX : 886-2-2696-2255
HWA YA	ADD : No. 52, Hwa Ya 1st Rd., Kwei-Shan Hsiang, Tao Yuan Hsien, Taiwan, R.O.C. TEL : 886-3-327-3456 FAX : 886-3-318-0055
LINKOU	ADD : No. 30-2, Dingfu Vil., Linkou Dist., New Taipei City 244, Taiwan, R.O.C. TEL : 886-2-2601-1640 FAX : 886-2-2601-1695
DUNGHU	ADD : No. 3, Lane 238, Kangle St., Neihu Chiu, Taipei 114, Taiwan, R.O.C. TEL : 886-2-2631-4739 FAX : 886-2-2631-9740
JUNGHE	ADD : 7Fl., No. 758, Jungjeng Rd., Junghe City, Taipei 235, Taiwan, R.O.C. TEL : 886-2-8227-2020 FAX : 886-2-8227-2626
NEIHU	ADD : 4Fl., No. 339, Hsin Hu 2 nd Rd., Taipei 114, Taiwan, R.O.C. TEL : 886-2-2794-8886 FAX : 886-2-2794-9777
JHUBEI	ADD : No.8, Lane 724, Bo-ai St., Jhubei City, HsinChu County 302, Taiwan, R.O.C. TEL : 886-3-656-9065 FAX : 886-3-656-9085

6 TAF CERTIFICATE OF ACCREDITATION



Certificate No. : L1190-111208

財團法人全國認證基金會
Taiwan Accreditation Foundation

Certificate of Accreditation

This is to certify that

Sporton International Inc.
EMC & Wireless Communications Laboratory
No.52, Hwa Ya 1st Rd., Hwa Ya Technology Park, Kwei-Shan Hsiang, Tao Yuan Hsien,
Taiwan, R.O.C.

is accredited in respect of laboratory

Accreditation Criteria : ISO/IEC 17025:2005

Accreditation Number : 1190

Originally Accredited : December 15, 2003

Effective Period : January 10, 2010 to January 09, 2013

Accredited Scope : Testing Field, see described in the Appendix

Specific Accreditation Program : Accreditation Program for Designated Testing Laboratory for Commodities Inspection
Accreditation Program for Telecommunication Equipment Testing Laboratory
Accreditation Program for BSMI Mutual Recognition Arrangement with Foreign Authorities



Jay-San Chen
President, Taiwan Accreditation Foundation
Date : December 08, 2011

P1, total 24 pages

The Appendix forms an integral part of this Certificate, which shall be invalid when use without the Appendix