



# FCC TEST REPORT (15.407)

**REPORT NO.:** RF120712C20-1  
**MODEL NO.:** WNDR4700  
(refer to item 3.1 for more detail)  
**FCC ID:** PY311400179  
**RECEIVED:** Jul. 12, 2012  
**TESTED:** Jul. 18 ~ Jul. 23, 2012  
**ISSUED:** Jul. 26, 2012

**APPLICANT:** NETGEAR, INC.

**ADDRESS:** 350 East Plumeria Drive San Jose, CA 95134

**ISSUED BY:** Bureau Veritas Consumer Products Services  
(H.K.) Ltd., Taoyuan Branch

**LAB ADDRESS:** No. 47, 14th Ling, Chia Pau Vil., Lin Kou Dist.,  
New Taipei City, Taiwan, R.O.C.

**TEST LOCATION:** No. 19, Hwa Ya 2nd Rd, Wen Hwa Tsuen, Kwei  
Shan Hsiang, Taoyuan Hsien 333, Taiwan, R.O.C.

This report should not be used by the client to claim product certification, approval, or endorsement by TAF or any government agencies.



This report is for your exclusive use. Any copying or replication of this report to or for any other person or entity, or use of our name or trademark, is permitted only with our prior written permission. This report sets forth our findings solely with respect to the test samples identified herein. The results set forth in this report are not indicative or representative of the quality or characteristics of the lot from which a test sample was taken or any similar or identical product unless specifically and expressly noted. Our report includes all of the tests requested by you and the results thereof based upon the information that you provided to us. You have 60 days from date of issuance of this report to notify us of any material error or omission caused by our negligence, provided, however, that such notice shall be in writing and shall specifically address the issue you wish to raise. A failure to raise such issue within the prescribed time shall constitute your unqualified acceptance of the completeness of this report, the tests conducted and the correctness of the report contents. Unless specific mention, the uncertainty of measurement has been explicitly taken into account to declare the compliance or non-compliance to the specification.

# TABLE OF CONTENTS

RELEASE CONTROL RECORD .....	4
1. CERTIFICATION .....	5
2. SUMMARY OF TEST RESULTS .....	6
2.1 MEASUREMENT UNCERTAINTY .....	6
3. GENERAL INFORMATION .....	7
3.1 GENERAL DESCRIPTION OF EUT .....	7
3.2 DESCRIPTION OF TEST MODES .....	8
3.2.1 TEST MODE APPLICABILITY AND TESTED CHANNEL DETAIL .....	9
3.3 DUTY CYCLE OF TEST SIGNAL .....	11
3.4 DESCRIPTION OF SUPPORT UNITS .....	12
3.4.1 CONFIGURATION OF SYSTEM UNDER TEST .....	12
3.5 GENERAL DESCRIPTION OF APPLIED STANDARDS .....	13
4. TEST TYPES AND RESULTS .....	14
4.1 RADIATED EMISSION AND BANDEDGE MEASUREMENT .....	14
4.1.1 LIMITS OF RADIATED EMISSION AND BANDEDGE MEASUREMENT .....	14
4.1.2 LIMITS OF UNWANTED EMISSION OUT OF THE RESTRICTED BANDS .....	14
4.1.3 TEST INSTRUMENTS .....	15
4.1.4 TEST PROCEDURES .....	16
4.1.5 DEVIATION FROM TEST STANDARD .....	16
4.1.6 TEST SETUP .....	17
4.1.7 EUT OPERATING CONDITION .....	17
4.1.8 TEST RESULTS .....	18
4.2 CONDUCTED EMISSION MEASUREMENT .....	27
4.2.1 LIMITS OF CONDUCTED EMISSION MEASUREMENT .....	27
4.2.2 TEST INSTRUMENTS .....	27
4.2.3 TEST PROCEDURES .....	28
4.2.4 DEVIATION FROM TEST STANDARD .....	28
4.2.5 TEST SETUP .....	28
4.2.6 EUT OPERATING CONDITIONS .....	28
4.2.7 TEST RESULTS .....	29
4.3 PEAK TRANSMIT POWER MEASUREMENT .....	31
4.3.1 LIMITS OF PEAK TRANSMIT POWER MEASUREMENT .....	31
4.3.2 TEST SETUP .....	31
4.3.3 TEST INSTRUMENTS .....	31
4.3.4 TEST PROCEDURE .....	32
4.3.5 DEVIATION FROM TEST STANDARD .....	32
4.3.6 EUT OPERATING CONDITIONS .....	32
4.3.7 TEST RESULTS .....	33
4.4 PEAK POWER SPECTRAL DENSITY MEASUREMENT .....	35
4.4.1 LIMITS OF PEAK POWER SPECTRAL DENSITY MEASUREMENT .....	35
4.4.2 TEST SETUP .....	35
4.4.3 TEST INSTRUMENTS .....	35
4.4.4 TEST PROCEDURES .....	35
4.4.5 DEVIATION FROM TEST STANDARD .....	35
4.4.6 EUT OPERATING CONDITIONS .....	35
4.4.7 TEST RESULTS .....	36
4.5 PEAK POWER EXCURSION MEASUREMENT .....	37
4.5.1 LIMITS OF PEAK POWER EXCURSION MEASUREMENT .....	37



A D T

4.5.2	TEST SETUP .....	37
4.5.3	TEST INSTRUMENTS.....	37
4.5.4	TEST PROCEDURE.....	37
4.5.5	DEVIATION FROM TEST STANDARD .....	37
4.5.6	EUT OPERATING CONDITIONS .....	37
4.5.7	TEST RESULTS .....	38
4.6	FREQUENCY STABILITY.....	41
4.6.1	LIMITS OF FREQUENCY STABILITY MEASUREMENT .....	41
4.6.2	TEST SETUP.....	41
4.6.3	TEST INSTRUMENTS.....	41
4.6.4	TEST PROCEDURE.....	42
4.6.5	DEVIATION FROM TEST STANDARD .....	42
4.6.6	EUT OPERATING CONDITION.....	42
4.6.7	TEST RESULTS .....	43
5.	PHOTOGRAPHS OF THE TEST CONFIGURATION.....	44
6.	INFORMATION ON THE TESTING LABORATORIES .....	45
7.	APPENDIX A - MODIFICATIONS RECORDERS FOR ENGINEERING CHANGES TO THE EUT BY THE LAB.....	46



A D T

## RELEASE CONTROL RECORD

ISSUE NO.	REASON FOR CHANGE	DATE ISSUED
RF120712C20-1	Original release	Jul. 26, 2012



# 1. CERTIFICATION

**PRODUCT:** N900 Wireless Dual Band Gigabit Router  
**MODEL NO.:** WNDR4700 (refer to item 3.1 for more detail)  
**BRAND:** NETGEAR  
**APPLICANT:** NETGEAR, INC.  
**TESTED:** Jul. 18 ~ Jul. 23, 2012  
**TEST SAMPLE:** ENGINEERING SAMPLE  
**STANDARDS:** **FCC Part 15, Subpart E (Section 15.407)**  
ANSI C63.10-2009

The above equipment (model: WNDR4700) has been tested by **Bureau Veritas Consumer Products Services (H.K.) Ltd., Taoyuan Branch**, and found compliance with the requirement of the above standards. The test record, data evaluation & Equipment Under Test (EUT) configurations represented herein are true and accurate accounts of the measurements of the sample's EMC characteristics under the conditions specified in this report.

PREPARED BY : Andrea Hsia , DATE : Jul. 26, 2012  
Andrea Hsia / Specialist

APPROVED BY : Gary Chang , DATE : Jul. 26, 2012  
Gary Chang / Technical Manager

## 2. SUMMARY OF TEST RESULTS

The EUT has been tested according to the following specifications:

APPLIED STANDARD: FCC PART 15, SUBPART E (SECTION 15.407)			
STANDARD SECTION	TEST TYPE	RESULT	REMARK
15.407(b)(6)	AC Power Conducted Emission	PASS	Meet the requirement of limit. Minimum passing margin is -10.09dB at 0.44297MHz.
15.407(b/1/2/3) (b)(6)	Spurious Emissions	PASS	Meet the requirement of limit. Minimum passing margin is -4.5dB at 62.95MHz.
15.407(a/1/2)	Peak Transmit Power	PASS	Meet the requirement of limit.
15.407(a)(6)	Peak Power Excursion	PASS	Meet the requirement of limit.
15.407(a/1/2)	Peak Power Spectral Density	PASS	Meet the requirement of limit.
15.407(g)	Frequency Stability	PASS	Meet the requirement of limit.
15.203	Antenna Requirement	PASS	Antenna connector is UFL not a standard connector.

### 2.1 MEASUREMENT UNCERTAINTY

Where relevant, the following measurement uncertainty levels have been estimated for tests performed on the EUT as specified in CISPR 16-4-2:

MEASUREMENT	FREQUENCY	UNCERTAINTY
Conducted emissions	9kHz~30MHz	2.44 dB
Radiated emissions	30MHz ~ 200MHz	3.19 dB
	200MHz ~1000MHz	3.21 dB
	1GHz ~ 18GHz	2.26 dB
	18GHz ~ 40GHz	1.94 dB

This uncertainty represents an expanded uncertainty expressed at approximately the 95% confidence level using a coverage factor of  $k = 2$ .

### 3. GENERAL INFORMATION

#### 3.1 GENERAL DESCRIPTION OF EUT

<b>EUT</b>	N900 Wireless Dual Band Gigabit Router
<b>MODEL NO.</b>	WNDR4700 (refer to note as below)
<b>POWER SUPPLY</b>	12Vdc (Adapter)
<b>MODULATION TYPE</b>	64QAM, 16QAM, QPSK, BPSK
<b>MODULATION TECHNOLOGY</b>	OFDM
<b>TRANSFER RATE</b>	802.11a: 54.0/ 48.0/ 36.0/ 24.0/ 18.0/ 12.0/ 9.0/ 6.0Mbps 802.11n: up to 450.0Mbps
<b>OPERATING FREQUENCY</b>	5180.0 ~ 5240.0MHz
<b>NUMBER OF CHANNEL</b>	4 for 802.11a, 802.11n (20MHz) 2 for 802.11n (40MHz)
<b>OUTPUT POWER</b>	31.7mW
<b>ANTENNA TYPE</b>	Off board PCB dipole antenna with 3dBi gain
<b>ANTENNA CONNECTOR</b>	UFL
<b>DATA CABLE</b>	NA
<b>I/O PORTS</b>	RJ45, USB
<b>ACCESSORY DEVICE</b>	Adapter

**NOTE:**

- The EUT incorporates a MIMO function. Physically, the EUT provides three completed transmitters and three receivers.

MODULATION MODE	TX FUNCTION
802.11b	3TX
802.11g	3TX
802.11a	3TX
802.11n (20MHz)	3TX
802.11n (40MHz)	3TX

- The following models are provided to this EUT.

Brand Name	Model No.	Difference
NETGEAR	WNDR4700	Without HDD
NETGEAR	WNDR4720	With HDD

- The following HDDs are provided to EUT.

Brand Name	Model No.	Spec.
WD	WD20EARX-00PASB0	2.0TB
Seagate	ST2000DM001	2000GB

\*WD HDD was the worst for the final tests.

4. The EUT consumes power from the following adapters.

ADAPTER 1	
BRAND	NETGEAR
MODEL	AD8180LF
INPUT POWER	100-240Vac, 50/60Hz, 1.5A
OUTPUT POWER	12Vdc, 5.0A
POEWR LINE	1.5 m non-shielded cable without core

ADAPTER 2	
BRAND	NETGEAR
MODEL	NU60-H120500-11
INPUT POWER	100-240Vac, 50/60Hz, 1.4A
OUTPUT POWER	12.0Vdc, 5.0A
POEWR LINE	1.5 m non-shielded cable with 1 core

\*Adapter 1 was the worst for the final tests.

5. The above EUT information is declared by manufacturer and for more detailed features description, please refer to the manufacturer's specifications or user's manual.

### 3.2 DESCRIPTION OF TEST MODES

4 channels are provided for 802.11a, 802.11n (20MHz):

CHANNEL	FREQUENCY	CHANNEL	FREQUENCY
36	5180MHz	44	5220MHz
40	5200MHz	48	5240MHz

2 channels are provided for 802.11n (40MHz):

CHANNEL	FREQUENCY	CHANNEL	FREQUENCY
38	5190MHz	46	5230MHz



### 3.2.1 TEST MODE APPLICABILITY AND TESTED CHANNEL DETAIL

EUT CONFIGURE MODE	APPLICABLE TO				DESCRIPTION
	RE $\geq$ 1G	RE<1G	PLC	APCM	
-	√	√	√	√	-

Where **RE $\geq$ 1G**: Radiated Emission above 1GHz      **RE<1G**: Radiated Emission below 1GHz  
**PLC**: Power Line Conducted Emission      **APCM**: Antenna Port Conducted Measurement

#### **RADIATED EMISSION TEST (ABOVE 1GHz):**

- Pre-Scan has been conducted to determine the worst-case mode from all possible combinations between available modulations, data rates and antenna ports (if EUT with antenna diversity architecture).
- Following channel(s) was (were) selected for the final test as listed below.

MODE	AVAILABLE CHANNEL	TESTED CHANNEL	MODULATION TECHNOLOGY	MODULATION TYPE	DATA RATE (Mbps)
802.11a	36 to 48	36, 40, 48	OFDM	BPSK	6.0
802.11n (20MHz)	36 to 48	36, 40, 48	OFDM	BPSK	7.2
802.11n (40MHz)	38 to 46	38, 46	OFDM	BPSK	15.0

#### **RADIATED EMISSION TEST (BELOW 1GHz):**

- Pre-Scan has been conducted to determine the worst-case mode from all possible combinations between available modulations, data rates and antenna ports (if EUT with antenna diversity architecture).
- Following channel(s) was (were) selected for the final test as listed below.

MODE	AVAILABLE CHANNEL	TESTED CHANNEL	MODULATION TECHNOLOGY	MODULATION TYPE	DATA RATE (Mbps)
802.11n (40MHz)	38 to 46	38	OFDM	BPSK	15.0

#### **POWER LINE CONDUCTED EMISSION TEST:**

- Pre-Scan has been conducted to determine the worst-case mode from all possible combinations between available modulations, data rates and antenna ports (if EUT with antenna diversity architecture).
- Following channel(s) was (were) selected for the final test as listed below.

MODE	AVAILABLE CHANNEL	TESTED CHANNEL	MODULATION TECHNOLOGY	MODULATION TYPE	DATA RATE (Mbps)
802.11n (40MHz)	38 to 46	38	OFDM	BPSK	15.0

**ANTENNA PORT CONDUCTED MEASUREMENT:**

- This item includes all test value of each mode, but only includes spectrum plot of worst value of each mode.
- Pre-Scan has been conducted to determine the worst-case mode from all possible combinations between available modulations, data rates and antenna ports (if EUT with antenna diversity architecture).
- Following channel(s) was (were) selected for the final test as listed below.

MODE	AVAILABLE CHANNEL	TESTED CHANNEL	MODULATION TECHNOLOGY	MODULATION TYPE	DATA RATE (Mbps)
802.11a	36 to 48	36, 40, 48	OFDM	BPSK	6.0
802.11n (20MHz)	36 to 48	36, 40, 48	OFDM	BPSK	7.2
802.11n (40MHz)	38 to 46	38, 46	OFDM	BPSK	15.0

**TEST CONDITION:**

APPLICABLE TO	ENVIRONMENTAL CONDITIONS	INPUT POWER	TESTED BY
RE≥1G	26deg. C, 69%RH	120Vac, 60Hz	Alen Wu
RE<1G	26deg. C, 69%RH	120Vac, 60Hz	Brad Wu
PLC	25deg. C, 65%RH	120Vac, 60Hz	Anderson Hong
APCM	26deg. C, 69%RH	120Vac, 60Hz	Brad Wu

### 3.3 DUTY CYCLE OF TEST SIGNAL

Duty cycle of test signal is > 98 %

**802.11a:** Duty cycle =  $2.05/2.07 = 0.99$

**802.11n (20MHz):** Duty cycle =  $1.92/1.94 = 0.99$

**802.11n (40MHz):** Duty cycle =  $0.952/0.970 = 0.98$

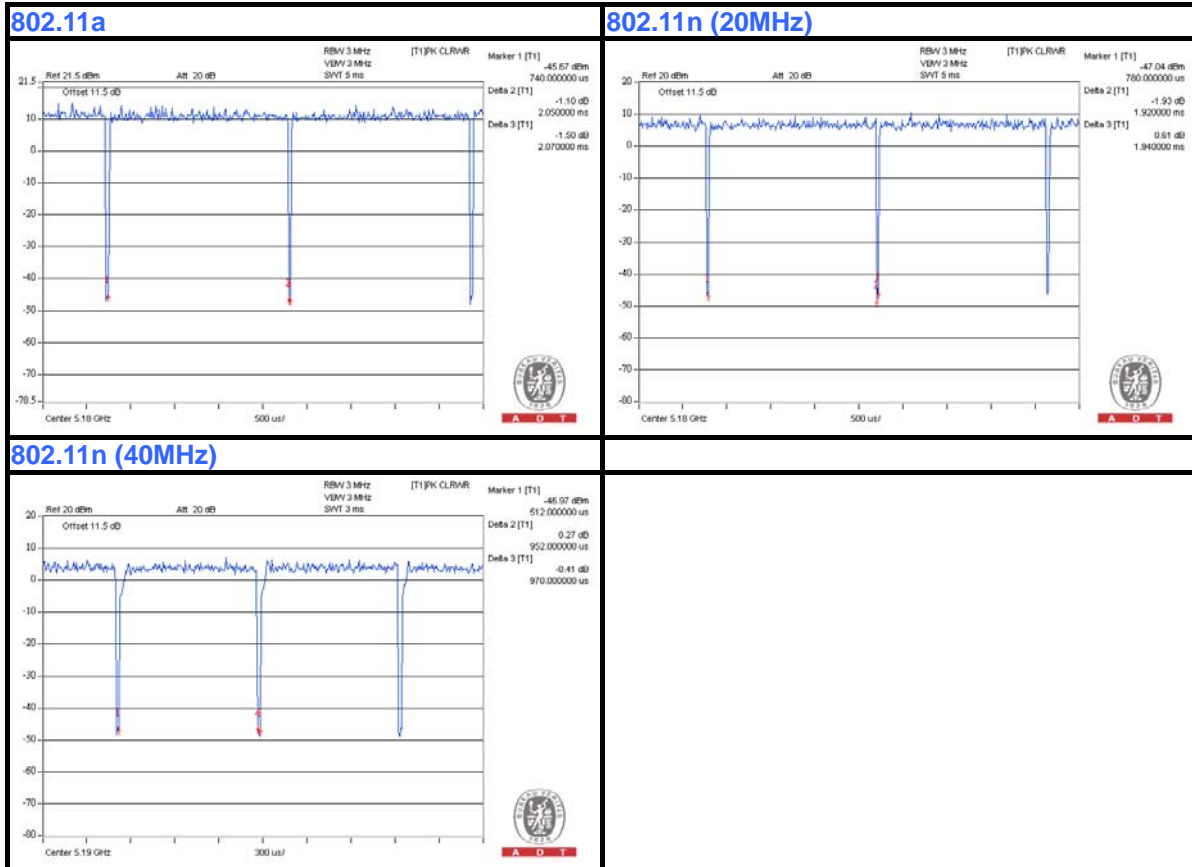

### 3.4 DESCRIPTION OF SUPPORT UNITS

The EUT has been tested as an independent unit together with other necessary accessories or support units. The following support units or accessories were used to form a representative test configuration during the tests.

NO.	PRODUCT	BRAND	MODEL NO.	SERIAL NO.	FCC ID
1	EXTERNAL HARD DISK	WD	WDBACY5000A BL-01	WX51C12T6215	NA
2	EXTERNAL HARD DISK	WD	WDBACY5000A BL-01	WX91EC1FPNR9	NA
3	NOTEBOOK	DELL	E5410	1HC2XM1	FCC DoC Approved
4	NOTEBOOK	DELL	E5410	6RP2YM1	FCC DoC Approved
5	SD CARD	Transcend	NA	NA	NA

NO.	SIGNAL CABLE DESCRIPTION OF THE ABOVE SUPPORT UNITS
1	0.45m non-shielded USB cable without core
2	0.45m non-shielded USB cable without core
3	10m RJ45 UTP cable
4	10m RJ45 UTP cable
5	NA

**NOTE:**

1. All power cords of the above support units are non shielded (1.8m).
2. Items 3~4 acted as communication partners to transfer data.

#### 3.4.1 CONFIGURATION OF SYSTEM UNDER TEST

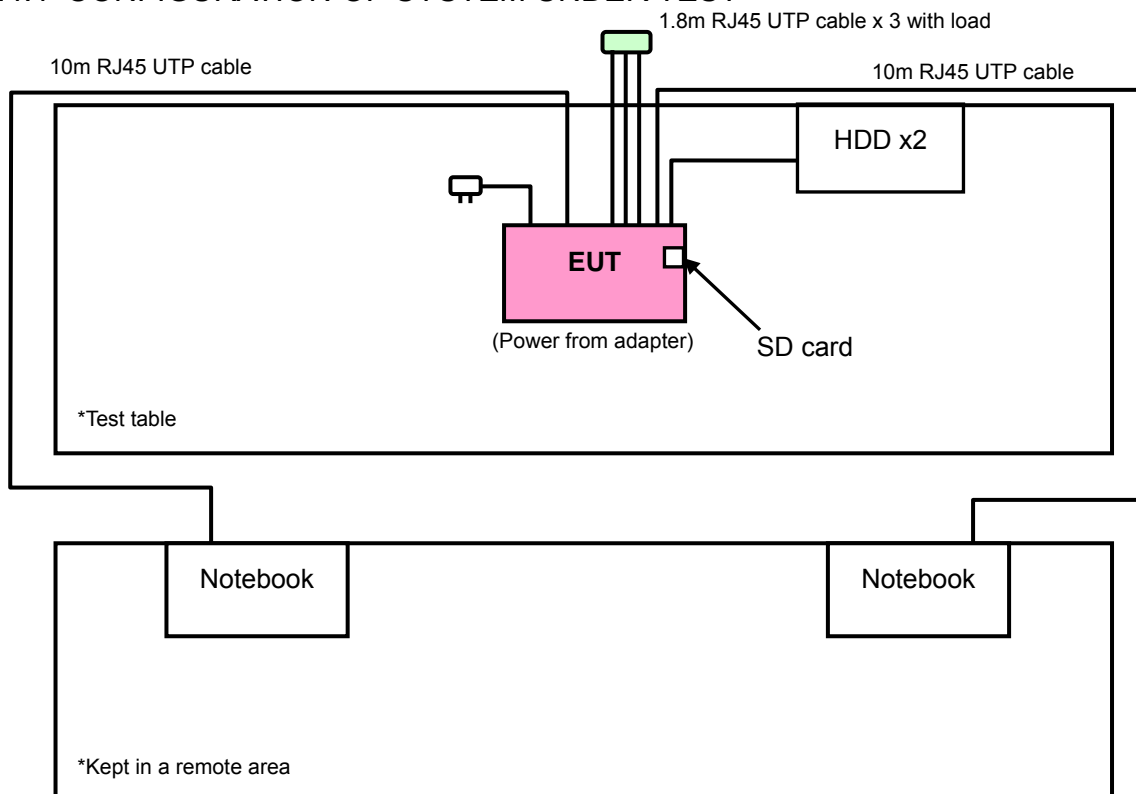

### 3.5 GENERAL DESCRIPTION OF APPLIED STANDARDS

The EUT is a RF Product. According to the specifications of the manufacturer, it must comply with the requirements of the following standards:

**FCC Part 15, Subpart E (15.407)**

**789033 D01 General UNII Test Procedures v01r01**

ANSI C63.10-2009

All test items have been performed and recorded as per the above standards.

**NOTE:** The EUT is also considered as a kind of computer peripheral, because the connection to computer is necessary for typical use. It has been verified to comply with the requirements of FCC Part 15, Subpart B, Class B (DoC). The test report has been issued separately.

## 4. TEST TYPES AND RESULTS

### 4.1 RADIATED EMISSION AND BANDEDGE MEASUREMENT

#### 4.1.1 LIMITS OF RADIATED EMISSION AND BANDEDGE MEASUREMENT

Radiated emissions which fall in the restricted bands must comply with the radiated emission limits specified as below table:

FREQUENCIES (MHz)	FIELD STRENGTH (microvolts/meter)	MEASUREMENT DISTANCE (meters)
0.009 ~ 0.490	2400/F(kHz)	300
0.490 ~ 1.705	24000/F(kHz)	30
1.705 ~ 30.0	30	30
30 ~ 88	100	3
88 ~ 216	150	3
216 ~ 960	200	3
Above 960	500	3

**NOTE:**

1. The lower limit shall apply at the transition frequencies.
2. Emission level (dBuV/m) = 20 log Emission level (uV/m).
3. For frequencies above 1000MHz, the field strength limits are based on average detector, however, the peak field strength of any emission shall not exceed the maximum permitted average limits, specified above by more than 20dB under any condition of modulation.

#### 4.1.2 LIMITS OF UNWANTED EMISSION OUT OF THE RESTRICTED BANDS

EIRP LIMIT (dBm)	EQUIVALENT FIELD STRENGTH AT 3m (dBµV/m)
<b>PK</b>	<b>PK</b>
-27	68.3

**NOTE:** The following formula is used to convert the equipment isotropic radiated power (eirp) to field strength:

$$E = \frac{1000000\sqrt{30P}}{3} \mu\text{V/m, where P is the eirp (Watts).}$$



#### 4.1.3 TEST INSTRUMENTS

DESCRIPTION & MANUFACTURER	MODEL NO.	SERIAL NO.	DATE OF CALIBRATION	DUE DATE OF CALIBRATION
Test Receiver ROHDE & SCHWARZ	ESI7	838496/016	Jan. 03, 2012	Jan. 02, 2013
Spectrum Analyzer ROHDE & SCHWARZ	FSU43	100115	Sep. 05, 2011	Sep. 04, 2012
BILOG Antenna SCHWARZBECK	VULB9168	9168-155	Apr. 06, 2012	Apr. 05, 2013
HORN Antenna SCHWARZBECK	BBHA 9120D	9120D-408	Jan. 05, 2012	Jan. 04, 2013
HORN Antenna SCHWARZBECK	BBHA 9170	148	Jul. 11, 2012	Jul. 10, 2013
Loop Antenna	HFH2-Z2	100070	Jan. 31, 2012	Jan. 30, 2014
Preamplifier Agilent	8449B	3008A01961	Oct. 29, 2011	Oct. 28, 2012
Preamplifier Agilent	8447D	2944A10738	Oct. 29, 2011	Oct. 28, 2012
RF signal cable HUBER+SUHNNER	SUCOFLEX 104	309220/4	Nov. 03, 2011	Nov. 02, 2012
RF signal cable HUBER+SUHNNER	SUCOFLEX 104	250724/4	Nov. 03, 2011	Nov. 02, 2012
RF signal cable HUBER+SUHNNER	SUCOFLEX 104	295012/4	Nov. 03, 2011	Nov. 02, 2012
Software ADT	ADT_Radiated_ V7.6.15.9.2	NA	NA	NA
Antenna Tower inn-co GmbH	MA 4000	010303	NA	NA
Antenna Tower Controller inn-co GmbH	CO2000	019303	NA	NA
Turn Table ADT	TT100.	TT93021704	NA	NA
Turn Table Controller ADT	SC100.	SC93021704	NA	NA
26GHz ~ 40GHz Amplifier	EM26400	815221	Oct. 29, 2011	Oct. 28, 2012
High Speed Peak Power Meter	ML2495A	0842014	Apr. 28, 2012	Apr. 27, 2013
Power Sensor	MA2411B	0738404	Apr. 28, 2012	Apr. 27, 2013
WIT Standard Temperature And Humidity Chamber	TH-4S-C	W981030	Jun. 13, 2012	Jun. 12, 2013

- NOTE:**
1. The calibration interval of the above test instruments is 12 months and the calibrations are traceable to NML/ROC and NIST/USA.
  2. The calibration interval of the loop antenna is 24 months and the calibrations are traceable to NML/ROC and NIST/USA.
  3. The test was performed in HwaYa Chamber 4.
  4. The horn antenna and HP preamplifier (model: 8449B) are used only for the measurement of emission frequency above 1GHz if tested.
  5. The FCC Site Registration No. is 460141.
  6. The IC Site Registration No. is IC7450F-4.

#### 4.1.4 TEST PROCEDURES

- a. The EUT was placed on the top of a rotating table 0.8 meters above the ground at a 3 meter semi-anechoic chamber. The table was rotated 360 degrees to determine the position of the highest radiation.
- b. The EUT was set 3 meters away from the interference-receiving antenna, which was mounted on the top of a variable-height antenna tower.
- c. The antenna is a broadband antenna, and its height is varied from one meter to four meters above the ground to determine the maximum value of the field strength. Both horizontal and vertical polarizations of the antenna are set to make the measurement.
- d. For each suspected emission, the EUT was arranged to its worst case and then the antenna was tuned to heights from 1 meter to 4 meters and the rotatable table was turned from 0 degrees to 360 degrees to find the maximum reading.
- e. The test-receiver system was set to Peak Detect Function and Specified Bandwidth with Maximum Hold Mode.
- f. If the emission level of the EUT in peak mode was 10dB lower than the limit specified, then testing could be stopped and the peak values of the EUT would be reported. Otherwise the emissions that did not have 10dB margin would be re-tested one by one using peak, quasi-peak or average method as specified and then reported in a data sheet.

**NOTE:**

1. The resolution bandwidth and video bandwidth of test receiver/spectrum analyzer is 120kHz for Peak detection (PK) and Quasi-peak detection (QP) at frequency below 1GHz.
2. The resolution bandwidth of test receiver/spectrum analyzer is 1MHz and video bandwidth is 3MHz for Peak detection at frequency above 1GHz.
3. The resolution bandwidth of test receiver/spectrum analyzer is 1MHz and the video bandwidth is 1kHz for Average detection (AV) at frequency above 1GHz.
4. All modes of operation were investigated and the worst-case emissions are reported.

#### 4.1.5 DEVIATION FROM TEST STANDARD

No deviation.



#### 4.1.6 TEST SETUP

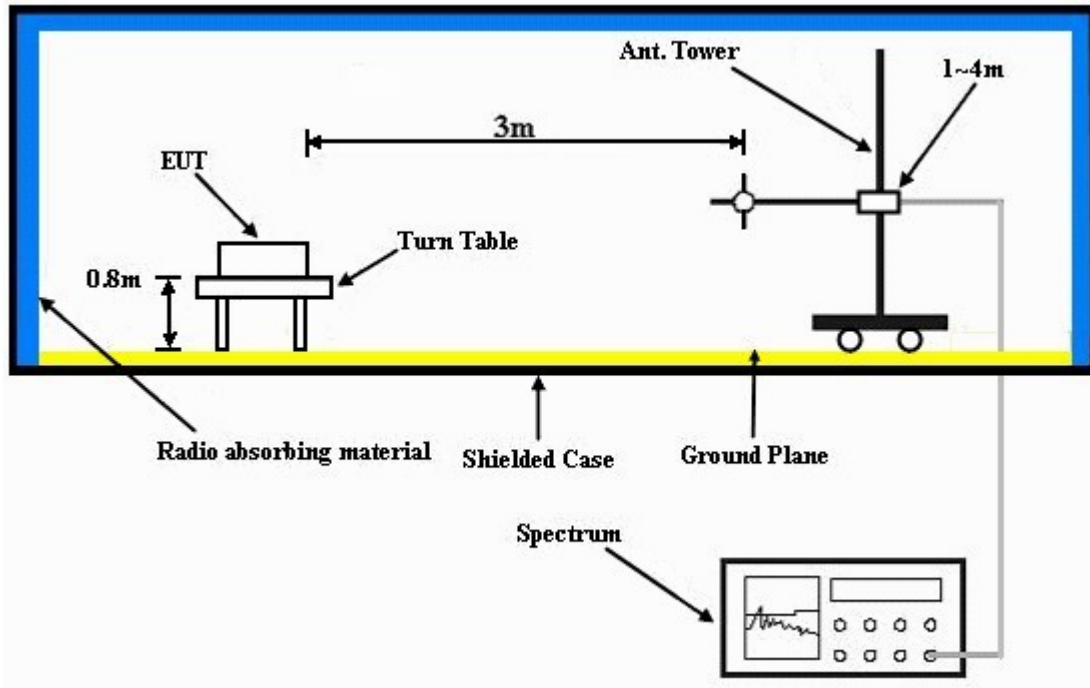

For the actual test configuration, please refer to the attached file (Test Setup Photo).

#### 4.1.7 EUT OPERATING CONDITION

- a. Placed the EUT on the testing table.
- b. Prepared two notebooks to act as communication partners and placed them outside of testing area.
- c. The communication partner connected with EUT via a RJ45 cable and run a test program (provided by manufacturer) to enable EUT under transmission condition continuously at specific channel frequency.
- d. The communication partner sent data to EUT by command "PING".

#### 4.1.8 TEST RESULTS

#### ABOVE 1GHz DATA :

#### 802.11a

EUT TEST CONDITION		MEASUREMENT DETAIL	
CHANNEL	Channel 36	FREQUENCY RANGE	1 ~ 40GHz
INPUT POWER (SYSTEM)	120Vac, 60 Hz	DETECTOR FUNCTION	Peak (PK) Average (AV)
ENVIRONMENTAL CONDITIONS	26deg. C, 69%RH	TESTED BY	Alan Wu

ANTENNA POLARITY & TEST DISTANCE: HORIZONTAL AT 3 M								
NO.	FREQ. (MHz)	EMISSION LEVEL (dBuV/m)	LIMIT (dBuV/m)	MARGIN (dB)	ANTENNA HEIGHT (m)	TABLE ANGLE (Degree)	RAW VALUE (dBuV)	CORRECTION FACTOR (dB/m)
1	5150.00	54.7 PK	74.0	-19.3	1.08 H	309	16.10	38.60
2	5150.00	41.0 AV	54.0	-13.0	1.08 H	309	2.40	38.60
3	*5180.00	102.8 PK			1.05 H	305	64.20	38.60
4	*5180.00	91.0 AV			1.05 H	305	52.40	38.60
5	#10360.00	56.3 PK	68.3	-12.0	1.00 H	214	6.80	49.50
ANTENNA POLARITY & TEST DISTANCE: VERTICAL AT 3 M								
NO.	FREQ. (MHz)	EMISSION LEVEL (dBuV/m)	LIMIT (dBuV/m)	MARGIN (dB)	ANTENNA HEIGHT (m)	TABLE ANGLE (Degree)	RAW VALUE (dBuV)	CORRECTION FACTOR (dB/m)
1	5150.00	55.2 PK	74.0	-18.8	1.00 V	101	16.60	38.60
2	5150.00	42.0 AV	54.0	-12.0	1.00 V	101	3.40	38.60
3	*5180.00	105.9 PK			1.00 V	100	67.30	38.60
4	*5180.00	94.3 AV			1.00 V	100	55.70	38.60
5	#10360.00	57.6 PK	68.3	-10.7	1.00 V	15	8.10	49.50

#### REMARKS:

1. Emission level (dBuV/m) = Raw Value (dBuV) + Correction Factor (dB/m).
2. Correction Factor (dB/m) = Antenna Factor (dB/m) + Cable Factor (dB).
3. The other emission levels were very low against the limit.
4. Margin value = Emission level – Limit value.
5. “ \* “: Fundamental frequency.
6. “#“: The radiated frequency is out the restricted band.



A D T

EUT TEST CONDITION		MEASUREMENT DETAIL	
CHANNEL	Channel 40	FREQUENCY RANGE	1 ~ 40GHz
INPUT POWER (SYSTEM)	120Vac, 60 Hz	DETECTOR FUNCTION	Peak (PK) Average (AV)
ENVIRONMENTAL CONDITIONS	26deg. C, 69%RH	TESTED BY	Alan Wu

ANTENNA POLARITY & TEST DISTANCE: HORIZONTAL AT 3 M								
NO.	FREQ. (MHz)	EMISSION LEVEL (dBuV/m)	LIMIT (dBuV/m)	MARGIN (dB)	ANTENNA HEIGHT (m)	TABLE ANGLE (Degree)	RAW VALUE (dBuV)	CORRECTION FACTOR (dB/m)
1	5120.00	55.0 PK	74.0	-19.0	1.00 H	158	16.50	38.50
2	5120.00	41.8 AV	54.0	-12.2	1.00 H	158	3.30	38.50
3	*5200.00	102.0 PK			1.00 H	153	63.40	38.60
4	*5200.00	90.9 AV			1.00 H	153	52.30	38.60
5	#10400.00	57.1 PK	68.3	-11.2	1.00 H	211	7.60	49.50
ANTENNA POLARITY & TEST DISTANCE: VERTICAL AT 3 M								
NO.	FREQ. (MHz)	EMISSION LEVEL (dBuV/m)	LIMIT (dBuV/m)	MARGIN (dB)	ANTENNA HEIGHT (m)	TABLE ANGLE (Degree)	RAW VALUE (dBuV)	CORRECTION FACTOR (dB/m)
1	5120.00	56.4 PK	74.0	-17.6	1.00 V	108	17.90	38.50
2	5120.00	42.6 AV	54.0	-11.4	1.00 V	108	4.10	38.50
3	*5200.00	105.7 PK			1.00 V	105	67.10	38.60
4	*5200.00	94.0 AV			1.00 V	105	55.40	38.60
5	#10400.00	58.3 PK	68.3	-10.0	1.00 V	18	8.80	49.50

**REMARKS:**

1. Emission level (dBuV/m) = Raw Value (dBuV) + Correction Factor (dB/m).
2. Correction Factor (dB/m) = Antenna Factor (dB/m) + Cable Factor (dB).
3. The other emission levels were very low against the limit.
4. Margin value = Emission level – Limit value.
5. " \* ": Fundamental frequency.
6. "#":The radiated frequency is out the restricted band.



A D T

EUT TEST CONDITION		MEASUREMENT DETAIL	
CHANNEL	Channel 48	FREQUENCY RANGE	1 ~ 40GHz
INPUT POWER (SYSTEM)	120Vac, 60 Hz	DETECTOR FUNCTION	Peak (PK) Average (AV)
ENVIRONMENTAL CONDITIONS	26deg. C, 69%RH	TESTED BY	Alan Wu

ANTENNA POLARITY & TEST DISTANCE: HORIZONTAL AT 3 M								
NO.	FREQ. (MHz)	EMISSION LEVEL (dBuV/m)	LIMIT (dBuV/m)	MARGIN (dB)	ANTENNA HEIGHT (m)	TABLE ANGLE (Degree)	RAW VALUE (dBuV)	CORRECTION FACTOR (dB/m)
1	*5240.00	103.8 PK			1.02 H	23	65.10	38.70
2	*5240.00	91.6 AV			1.02 H	23	52.90	38.70
3	5350.00	56.1 PK	74.0	-17.9	1.04 H	25	17.30	38.80
4	5350.00	43.0 AV	54.0	-11.0	1.04 H	25	4.20	38.80
5	#10480.00	58.0 PK	68.3	-10.3	1.00 H	206	8.30	49.70
ANTENNA POLARITY & TEST DISTANCE: VERTICAL AT 3 M								
NO.	FREQ. (MHz)	EMISSION LEVEL (dBuV/m)	LIMIT (dBuV/m)	MARGIN (dB)	ANTENNA HEIGHT (m)	TABLE ANGLE (Degree)	RAW VALUE (dBuV)	CORRECTION FACTOR (dB/m)
1	*5240.00	106.0 PK			1.00 V	101	67.30	38.70
2	*5240.00	94.3 AV			1.00 V	101	55.60	38.70
3	5350.00	57.4 PK	74.0	-16.6	1.00 V	101	18.60	38.80
4	5350.00	44.0 AV	54.0	-10.0	1.00 V	101	5.20	38.80
5	#10480.00	59.1 PK	68.3	-9.2	1.00 V	11	9.40	49.70

**REMARKS:**

1. Emission level (dBuV/m) = Raw Value (dBuV) + Correction Factor (dB/m).
2. Correction Factor (dB/m) = Antenna Factor (dB/m) + Cable Factor (dB).
3. The other emission levels were very low against the limit.
4. Margin value = Emission level – Limit value.
5. " \* ": Fundamental frequency.
6. "#": The radiated frequency is out the restricted band.

802.11n (20MHz)

EUT TEST CONDITION		MEASUREMENT DETAIL	
CHANNEL	Channel 36	FREQUENCY RANGE	1 ~ 40GHz
INPUT POWER (SYSTEM)	120Vac, 60 Hz	DETECTOR FUNCTION	Peak (PK) Average (AV)
ENVIRONMENTAL CONDITIONS	26deg. C, 69%RH	TESTED BY	Alan Wu

ANTENNA POLARITY & TEST DISTANCE: HORIZONTAL AT 3 M								
NO.	FREQ. (MHz)	EMISSION LEVEL (dBuV/m)	LIMIT (dBuV/m)	MARGIN (dB)	ANTENNA HEIGHT (m)	TABLE ANGLE (Degree)	RAW VALUE (dBuV)	CORRECTION FACTOR (dB/m)
1	5150.00	55.3 PK	74.0	-18.7	1.01 H	304	16.70	38.60
2	5150.00	42.0 AV	54.0	-12.0	1.01 H	304	3.40	38.60
3	*5180.00	102.8 PK			1.03 H	302	64.20	38.60
4	*5180.00	90.8 AV			1.03 H	302	52.20	38.60
5	#10360.00	58.2 PK	68.3	-10.1	1.00 H	241	8.70	49.50

ANTENNA POLARITY & TEST DISTANCE: VERTICAL AT 3 M								
NO.	FREQ. (MHz)	EMISSION LEVEL (dBuV/m)	LIMIT (dBuV/m)	MARGIN (dB)	ANTENNA HEIGHT (m)	TABLE ANGLE (Degree)	RAW VALUE (dBuV)	CORRECTION FACTOR (dB/m)
1	5150.00	56.7 PK	74.0	-17.3	1.00 V	91	18.10	38.60
2	5150.00	43.0 AV	54.0	-11.0	1.00 V	91	4.40	38.60
3	*5180.00	105.8 PK			1.00 V	98	67.20	38.60
4	*5180.00	94.1 AV			1.00 V	98	55.50	38.60
5	#10360.00	59.3 PK	68.3	-9.0	1.00 V	11	9.80	49.50

**REMARKS:**

1. Emission level (dBuV/m) = Raw Value (dBuV) + Correction Factor (dB/m).
2. Correction Factor (dB/m) = Antenna Factor (dB/m) + Cable Factor (dB).
3. The other emission levels were very low against the limit.
4. Margin value = Emission level – Limit value.
5. “ \* “: Fundamental frequency.
6. “#”: The radiated frequency is out the restricted band.



A D T

EUT TEST CONDITION		MEASUREMENT DETAIL	
CHANNEL	Channel 40	FREQUENCY RANGE	1 ~ 40GHz
INPUT POWER (SYSTEM)	120Vac, 60 Hz	DETECTOR FUNCTION	Peak (PK) Average (AV)
ENVIRONMENTAL CONDITIONS	26deg. C, 69%RH	TESTED BY	Alan Wu

ANTENNA POLARITY & TEST DISTANCE: HORIZONTAL AT 3 M								
NO.	FREQ. (MHz)	EMISSION LEVEL (dBuV/m)	LIMIT (dBuV/m)	MARGIN (dB)	ANTENNA HEIGHT (m)	TABLE ANGLE (Degree)	RAW VALUE (dBuV)	CORRECTION FACTOR (dB/m)
1	5120.00	56.0 PK	74.0	-18.0	1.00 H	155	17.50	38.50
2	5120.00	42.1 AV	54.0	-11.9	1.00 H	155	3.60	38.50
3	*5200.00	102.7 PK			1.00 H	155	64.10	38.60
4	*5200.00	90.6 AV			1.00 H	155	52.00	38.60
5	#10400.00	59.1 PK	68.3	-9.2	1.00 H	121	9.60	49.50
ANTENNA POLARITY & TEST DISTANCE: VERTICAL AT 3 M								
NO.	FREQ. (MHz)	EMISSION LEVEL (dBuV/m)	LIMIT (dBuV/m)	MARGIN (dB)	ANTENNA HEIGHT (m)	TABLE ANGLE (Degree)	RAW VALUE (dBuV)	CORRECTION FACTOR (dB/m)
1	5120.00	57.0 PK	74.0	-17.0	1.00 V	81	18.50	38.50
2	5120.00	43.8 AV	54.0	-10.2	1.00 V	81	5.30	38.50
3	*5200.00	106.2 PK			1.00 V	93	67.60	38.60
4	*5200.00	94.9 AV			1.00 V	93	56.30	38.60
5	#10400.00	60.1 PK	68.3	-8.2	1.00 V	10	10.60	49.50

**REMARKS:**

1. Emission level (dBuV/m) = Raw Value (dBuV) + Correction Factor (dB/m).
2. Correction Factor (dB/m) = Antenna Factor (dB/m) + Cable Factor (dB).
3. The other emission levels were very low against the limit.
4. Margin value = Emission level – Limit value.
5. " \* ": Fundamental frequency.
6. "#":The radiated frequency is out the restricted band.



A D T

EUT TEST CONDITION		MEASUREMENT DETAIL	
CHANNEL	Channel 48	FREQUENCY RANGE	1 ~ 40GHz
INPUT POWER (SYSTEM)	120Vac, 60 Hz	DETECTOR FUNCTION	Peak (PK) Average (AV)
ENVIRONMENTAL CONDITIONS	26deg. C, 69%RH	TESTED BY	Alan Wu

ANTENNA POLARITY & TEST DISTANCE: HORIZONTAL AT 3 M								
NO.	FREQ. (MHz)	EMISSION LEVEL (dBuV/m)	LIMIT (dBuV/m)	MARGIN (dB)	ANTENNA HEIGHT (m)	TABLE ANGLE (Degree)	RAW VALUE (dBuV)	CORRECTION FACTOR (dB/m)
1	*5240.00	104.4 PK			1.03 H	20	65.70	38.70
2	*5240.00	91.8 AV			1.03 H	20	53.10	38.70
3	5350.00	57.9 PK	74.0	-16.1	1.03 H	16	19.10	38.80
4	5350.00	44.0 AV	54.0	-10.0	1.03 H	16	5.20	38.80
5	#10480.00	59.0 PK	68.3	-9.3	1.00 H	260	9.30	49.70
ANTENNA POLARITY & TEST DISTANCE: VERTICAL AT 3 M								
NO.	FREQ. (MHz)	EMISSION LEVEL (dBuV/m)	LIMIT (dBuV/m)	MARGIN (dB)	ANTENNA HEIGHT (m)	TABLE ANGLE (Degree)	RAW VALUE (dBuV)	CORRECTION FACTOR (dB/m)
1	*5240.00	106.0 PK			1.00 V	99	67.30	38.70
2	*5240.00	94.4 AV			1.00 V	99	55.70	38.70
3	5350.00	58.1 PK	74.0	-15.9	1.00 V	95	19.30	38.80
4	5350.00	45.0 AV	54.0	-9.0	1.00 V	95	6.20	38.80
5	#10480.00	60.0 PK	68.3	-8.3	1.00 V	15	10.30	49.70

**REMARKS:**

1. Emission level (dBuV/m) = Raw Value (dBuV) + Correction Factor (dB/m).
2. Correction Factor (dB/m) = Antenna Factor (dB/m) + Cable Factor (dB).
3. The other emission levels were very low against the limit.
4. Margin value = Emission level – Limit value.
5. " \* ": Fundamental frequency.
6. "#": The radiated frequency is out the restricted band.



## 802.11n (40MHz)

EUT TEST CONDITION		MEASUREMENT DETAIL	
CHANNEL	Channel 38	FREQUENCY RANGE	1 ~ 40GHz
INPUT POWER (SYSTEM)	120Vac, 60 Hz	DETECTOR FUNCTION	Peak (PK) Average (AV)
ENVIRONMENTAL CONDITIONS	26deg. C, 69%RH	TESTED BY	Alan Wu

ANTENNA POLARITY & TEST DISTANCE: HORIZONTAL AT 3 M								
NO.	FREQ. (MHz)	EMISSION LEVEL (dBuV/m)	LIMIT (dBuV/m)	MARGIN (dB)	ANTENNA HEIGHT (m)	TABLE ANGLE (Degree)	RAW VALUE (dBuV)	CORRECTION FACTOR (dB/m)
1	5150.00	57.1 PK	74.0	-16.9	1.00 H	170	18.50	38.60
2	5150.00	43.3 AV	54.0	-10.7	1.00 H	170	4.70	38.60
3	*5190.00	101.5 PK			1.00 H	172	62.90	38.60
4	*5190.00	90.4 AV			1.00 H	172	51.80	38.60
5	#10380.00	57.1 PK	68.3	-11.2	1.00 H	246	7.60	49.50

ANTENNA POLARITY & TEST DISTANCE: VERTICAL AT 3 M								
NO.	FREQ. (MHz)	EMISSION LEVEL (dBuV/m)	LIMIT (dBuV/m)	MARGIN (dB)	ANTENNA HEIGHT (m)	TABLE ANGLE (Degree)	RAW VALUE (dBuV)	CORRECTION FACTOR (dB/m)
1	5150.00	58.3 PK	74.0	-15.7	1.00 V	108	19.70	38.60
2	5150.00	44.9 AV	54.0	-9.1	1.00 V	108	6.30	38.60
3	*5190.00	105.8 PK			1.00 V	108	67.20	38.60
4	*5190.00	94.7 AV			1.00 V	108	56.10	38.60
5	#10380.00	58.3 PK	68.3	-10.0	1.00 V	19	8.80	49.50

## REMARKS:

1. Emission level (dBuV/m) = Raw Value (dBuV) + Correction Factor (dB/m).
2. Correction Factor (dB/m) = Antenna Factor (dB/m) + Cable Factor (dB).
3. The other emission levels were very low against the limit.
4. Margin value = Emission level – Limit value.
5. “ \* “: Fundamental frequency.
6. “#”: The radiated frequency is out the restricted band.





A D T

EUT TEST CONDITION		MEASUREMENT DETAIL	
CHANNEL	Channel 46	FREQUENCY RANGE	1 ~ 40GHz
INPUT POWER (SYSTEM)	120Vac, 60 Hz	DETECTOR FUNCTION	Peak (PK) Average (AV)
ENVIRONMENTAL CONDITIONS	26deg. C, 69%RH	TESTED BY	Alan Wu

ANTENNA POLARITY & TEST DISTANCE: HORIZONTAL AT 3 M								
NO.	FREQ. (MHz)	EMISSION LEVEL (dBuV/m)	LIMIT (dBuV/m)	MARGIN (dB)	ANTENNA HEIGHT (m)	TABLE ANGLE (Degree)	RAW VALUE (dBuV)	CORRECTION FACTOR (dB/m)
1	5150.00	56.6 PK	74.0	-17.4	1.04 H	24	18.00	38.60
2	5150.00	43.0 AV	54.0	-11.0	1.04 H	24	4.40	38.60
3	*5230.00	102.3 PK			1.02 H	23	63.70	38.60
4	*5230.00	90.7 AV			1.02 H	23	52.10	38.60
5	#10460.00	57.0 PK	68.3	-11.3	1.00 H	236	7.40	49.60
ANTENNA POLARITY & TEST DISTANCE: VERTICAL AT 3 M								
NO.	FREQ. (MHz)	EMISSION LEVEL (dBuV/m)	LIMIT (dBuV/m)	MARGIN (dB)	ANTENNA HEIGHT (m)	TABLE ANGLE (Degree)	RAW VALUE (dBuV)	CORRECTION FACTOR (dB/m)
1	5150.00	57.9 PK	74.0	-16.1	1.00 V	108	19.30	38.60
2	5150.00	44.0 AV	54.0	-10.0	1.00 V	108	5.40	38.60
3	*5230.00	104.9 PK			1.00 V	104	66.30	38.60
4	*5230.00	94.1 AV			1.00 V	104	55.50	38.60
5	#10460.00	58.0 PK	68.3	-10.3	1.00 V	18	8.40	49.60

**REMARKS:**

1. Emission level (dBuV/m) = Raw Value (dBuV) + Correction Factor (dB/m).
2. Correction Factor (dB/m) = Antenna Factor (dB/m) + Cable Factor (dB).
3. The other emission levels were very low against the limit.
4. Margin value = Emission level – Limit value.
5. " \* ": Fundamental frequency.
6. "#": The radiated frequency is out the restricted band.

**BELOW 1GHz WORST-CASE DATA : 802.11n (40MHz)**

EUT TEST CONDITION		MEASUREMENT DETAIL	
CHANNEL	Channel 38	FREQUENCY RANGE	Below 1000MHz
INPUT POWER (SYSTEM)	120Vac, 60 Hz	DETECTOR FUNCTION	Quasi-Peak
ENVIRONMENTAL CONDITIONS	26deg. C, 69%RH	TESTED BY	Brad Wu

ANTENNA POLARITY & TEST DISTANCE: HORIZONTAL AT 3 M								
NO.	FREQ. (MHz)	EMISSION LEVEL (dBuV/m)	LIMIT (dBuV/m)	MARGIN (dB)	ANTENNA HEIGHT (m)	TABLE ANGLE (Degree)	RAW VALUE (dBuV)	CORRECTION FACTOR (dB/m)
1	125.17	30.6 QP	43.5	-12.9	1.50 H	98	18.00	12.60
2	389.59	35.8 QP	46.0	-10.2	2.00 H	23	17.70	18.10
3	533.47	37.8 QP	46.0	-8.2	1.75 H	4	15.90	21.90
4	624.85	37.3 QP	46.0	-8.7	1.25 H	167	13.60	23.70
5	751.23	36.1 QP	46.0	-9.9	1.50 H	98	10.30	25.80
6	875.67	35.3 QP	46.0	-10.7	1.00 H	150	7.10	28.20
ANTENNA POLARITY & TEST DISTANCE: VERTICAL AT 3 M								
NO.	FREQ. (MHz)	EMISSION LEVEL (dBuV/m)	LIMIT (dBuV/m)	MARGIN (dB)	ANTENNA HEIGHT (m)	TABLE ANGLE (Degree)	RAW VALUE (dBuV)	CORRECTION FACTOR (dB/m)
1	62.95	35.5 QP	40.0	-4.5	1.49 V	149	22.30	13.20
2	286.55	33.3 QP	46.0	-12.7	1.49 V	234	18.10	15.20
3	416.81	33.6 QP	46.0	-12.4	1.24 V	16	14.70	18.90
4	624.85	34.9 QP	46.0	-11.1	1.74 V	317	11.20	23.70
5	764.84	34.4 QP	46.0	-11.6	1.24 V	221	8.20	26.20
6	875.67	35.6 QP	46.0	-10.4	1.24 V	8	7.40	28.20

**REMARKS:**

1. Emission level (dBuV/m) = Raw Value (dBuV) + Correction Factor (dB/m).
2. Correction Factor (dB/m) = Antenna Factor (dB/m) + Cable Factor (dB).
3. The other emission levels were very low against the limit.
4. Margin value = Emission level – Limit value.

## 4.2 CONDUCTED EMISSION MEASUREMENT

### 4.2.1 LIMITS OF CONDUCTED EMISSION MEASUREMENT

FREQUENCY OF EMISSION (MHz)	CONDUCTED LIMIT (dB $\mu$ V)	
	Quasi-peak	Average
0.15 ~ 0.5	66 to 56	56 to 46
0.5 ~ 5	56	46
5 ~ 30	60	50

- NOTE:**
1. The lower limit shall apply at the transition frequencies.
  2. The limit decreases in line with the logarithm of the frequency in the range of 0.15 to 0.50MHz.
  3. All emanations from a class A/B digital device or system, including any network of conductors and apparatus connected thereto, shall not exceed the level of field strengths specified above.

### 4.2.2 TEST INSTRUMENTS

DESCRIPTION & MANUFACTURER	MODEL NO.	SERIAL NO.	DATE OF CALIBRATION	DUE DATE OF CALIBRATION
Test Receiver ROHDE & SCHWARZ	ESCS30	100291	Nov. 23, 2011	Nov. 22, 2012
RF signal cable Woken	5D-FB	Cable-HYC01-01	Dec. 29, 2011	Dec. 28, 2012
LISN ROHDE & SCHWARZ (Peripheral)	ESH3-Z5	100312	Jul. 02, 2012	Jul. 01, 2013
LISN ROHDE & SCHWARZ (EUT)	ESH3-Z5	835239/001	Feb. 07, 2012	Feb. 06, 2013
Software ADT	BV ADT_Cond_ V7.3.7.3	NA	NA	NA

- NOTE:**
1. The calibration interval of the above test instruments is 12 months and the calibrations are traceable to NML/ROC and NIST/USA.
  2. The test was performed in HwaYa Shielded Room 1.
  3. The VCCI Site Registration No. is C-2040.

#### 4.2.3 TEST PROCEDURES

- The EUT was placed 0.4 meters from the conducting wall of the shielded room with EUT being connected to the power mains through a line impedance stabilization network (LISN). Other support units were connected to the power mains through another LISN. The two LISNs provide 50 ohm/ 50uH of coupling impedance for the measuring instrument.
- Both lines of the power mains connected to the EUT were checked for maximum conducted interference.
- The frequency range from 150kHz to 30MHz was searched. Emission levels under (Limit - 20dB) was not recorded.

**NOTE:** All modes of operation were investigated and the worst-case emissions are reported.

#### 4.2.4 DEVIATION FROM TEST STANDARD

No deviation.

#### 4.2.5 TEST SETUP

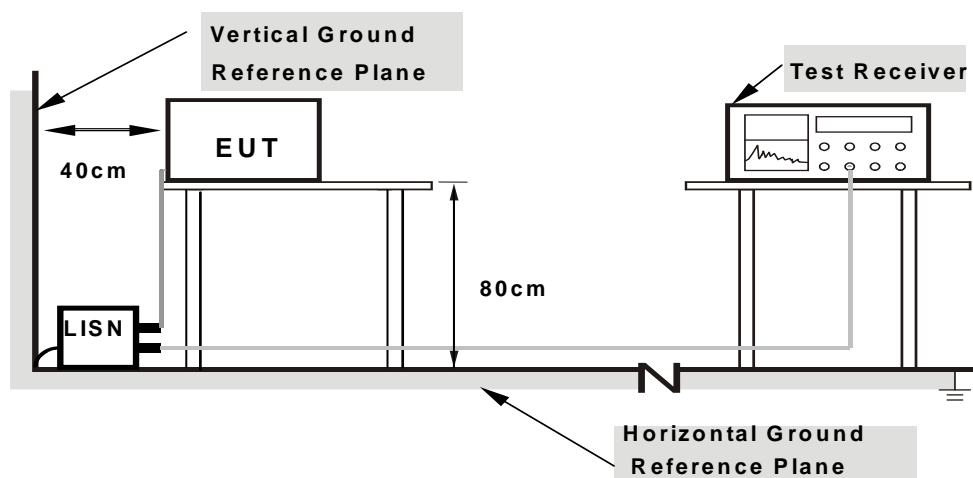

- Note:**
- Support units were connected to second LISN.
  - Both of LISNs (AMN) are 80 cm from EUT and at least 80 cm from other units and other metal planes

For the actual test configuration, please refer to the attached file (Test Setup Photo).

#### 4.2.6 EUT OPERATING CONDITIONS

Same as 4.1.6.

### 4.2.7 TEST RESULTS

#### CONDUCTED WORST-CASE DATA : 802.11n (40MHz)

PHASE	Line 1	6dB BANDWIDTH	9kHz
-------	--------	---------------	------

No	Freq. [MHz]	Corr. Factor (dB)	Reading Value		Emission Level		Limit		Margin	
			[dB (uV)]		[dB (uV)]		[dB (uV)]		(dB)	
			Q.P.	AV.	Q.P.	AV.	Q.P.	AV.	Q.P.	AV.
1	0.18906	0.13	43.62	29.80	43.75	29.93	64.08	54.08	-20.33	-24.15
2	0.24375	0.13	37.25	23.20	37.38	23.33	61.97	51.97	-24.59	-28.64
3	0.45859	0.14	43.89	32.49	44.03	32.63	56.72	46.72	-12.69	-14.09
4	0.96250	0.19	35.91	20.94	36.10	21.13	56.00	46.00	-19.90	-24.87
5	9.00781	0.59	27.06	19.10	27.65	19.69	60.00	50.00	-32.35	-30.31
6	21.21094	1.23	33.35	28.53	34.58	29.76	60.00	50.00	-25.42	-20.24

#### REMARKS:

1. Q.P. and AV. are abbreviations of quasi-peak and average individually.
2. The emission levels of other frequencies were very low against the limit.
3. Margin value = Emission level - Limit value
4. Correction factor = Insertion loss + Cable loss
5. Emission Level = Correction Factor + Reading Value.

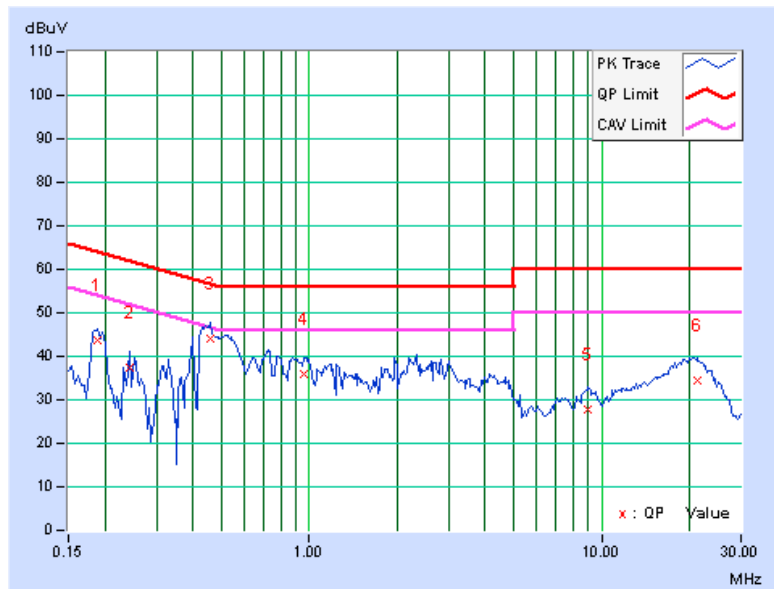

PHASE	Line 2	6dB BANDWIDTH	9kHz
-------	--------	---------------	------

No	Freq. [MHz]	Corr. Factor (dB)	Reading Value		Emission Level		Limit		Margin	
			[dB (uV)]		[dB (uV)]		[dB (uV)]		(dB)	
			Q.P.	AV.	Q.P.	AV.	Q.P.	AV.	Q.P.	AV.
1	0.19297	0.14	44.08	32.03	44.22	32.17	63.91	53.91	-19.69	-21.74
2	0.25156	0.14	37.56	26.89	37.70	27.03	61.71	51.71	-24.00	-24.67
<b>3</b>	<b>0.44297</b>	<b>0.15</b>	<b>45.25</b>	<b>36.76</b>	<b>45.40</b>	<b>36.91</b>	<b>57.01</b>	<b>47.01</b>	<b>-11.60</b>	<b>-10.09</b>
4	1.84766	0.23	35.58	20.94	35.81	21.17	56.00	46.00	-20.19	-24.83
5	10.42188	0.61	32.89	24.77	33.50	25.38	60.00	50.00	-26.50	-24.62
6	21.89063	1.04	33.92	28.92	34.96	29.96	60.00	50.00	-25.04	-20.04

**REMARKS:**

1. Q.P. and AV. are abbreviations of quasi-peak and average individually.
2. The emission levels of other frequencies were very low against the limit.
3. Margin value = Emission level - Limit value
4. Correction factor = Insertion loss + Cable loss
5. Emission Level = Correction Factor + Reading Value.

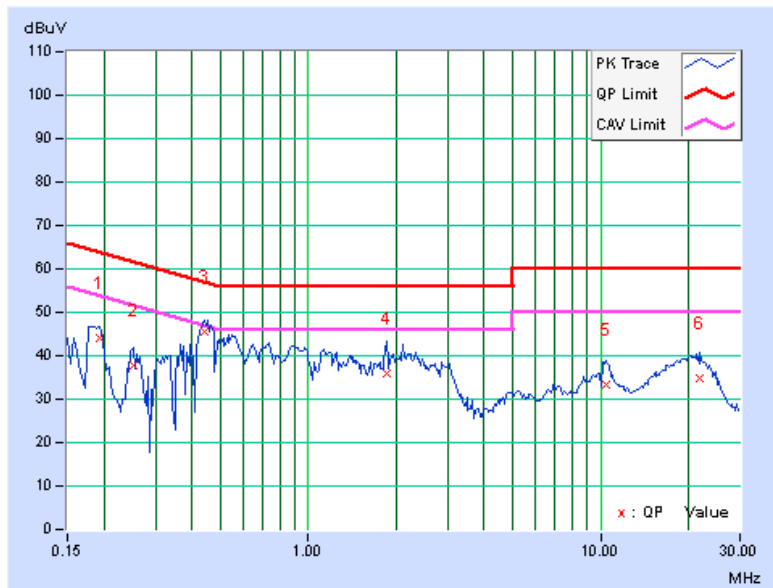

### 4.3 PEAK TRANSMIT POWER MEASUREMENT

#### 4.3.1 LIMITS OF PEAK TRANSMIT POWER MEASUREMENT

FREQUENCY BAND	LIMIT
5.15 ~ 5.25GHz	The lesser of 50mW (17dBm) or 4dBm + 10logB

**NOTE:** Where B is the 26dB emission bandwidth in MHz.

#### 4.3.2 TEST SETUP

##### FOR POWER OUTPUT MEASUREMENT

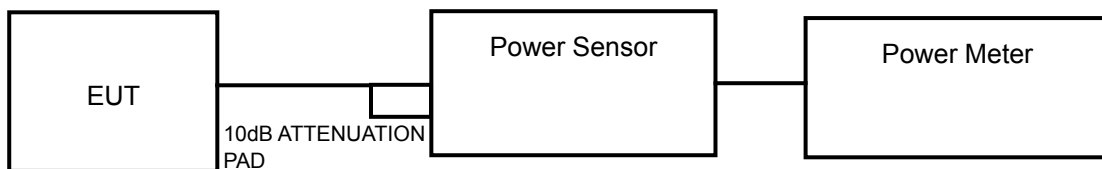

##### FOR 26dB BANDWIDTH

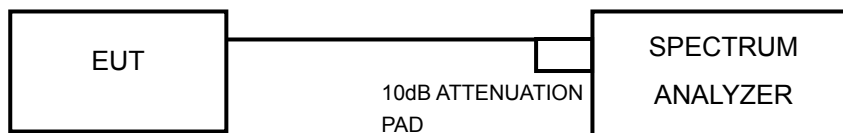

#### 4.3.3 TEST INSTRUMENTS

Refer to section 4.1.3 to get information of above instrument.

#### 4.3.4 TEST PROCEDURE

##### FOR AVERAGE POWER MEASUREMENT

Method PM is used to perform output power measurement, trigger and gating function of wide band power meter is enabled to measure max output power of TX on burst. Duty factor is not added to measured value.

##### FOR 26dB BANDWIDTH

- 1) Set RBW = approximately 1% of the emission bandwidth.
- 2) Set the VBW > RBW.
- 3) Detector = Peak.
- 4) Trace mode = max hold.
- 5) Measure the maximum width of the emission that is 26 dB down from the peak of the emission. Compare this with the RBW setting of the analyzer. Readjust RBW and repeat measurement as needed until the RBW/EBW ratio is approximately 1%.

#### 4.3.5 DEVIATION FROM TEST STANDARD

No deviation.

#### 4.3.6 EUT OPERATING CONDITIONS

The software provided by client to enable the EUT under transmission condition continuously at specific channel frequencies individually.



### 4.3.7 TEST RESULTS

#### POWER OUTPUT: 802.11a

CHAN.	CHAN. FREQ. (MHz)	AVERAGE POWER (dBm)			TOTAL POWER (mW)	TOTAL POWER (dBm)	POWER LIMIT (dBm)	PASS / FAIL
		CHAIN 0	CHAIN 1	CHAIN 2				
36	5180	8.12	8.13	8.34	19.8	12.97	15.2	PASS
40	5200	8.23	8.05	8.38	19.9	12.99	15.2	PASS
48	5240	8.41	8.15	8.12	20.0	13.00	15.2	PASS

**NOTE:** Directional gain =  $3\text{dBi} + 10\log(3) = 7.8\text{dBi} > 6\text{dBi}$  , so the limit shall be reduced to  $17 - (7.8 - 6) = 15.2\text{dBm}$ .

#### 802.11n (20MHz)

CHAN.	CHAN. FREQ. (MHz)	AVERAGE POWER (dBm)			TOTAL POWER (mW)	TOTAL POWER (dBm)	POWER LIMIT (dBm)	PASS / FAIL
		CHAIN 0	CHAIN 1	CHAIN 2				
36	5180	8.00	8.04	8.32	19.5	12.89	15.2	PASS
40	5200	8.40	8.13	8.38	20.3	13.08	15.2	PASS
48	5240	8.52	8.30	8.02	20.2	13.06	15.2	PASS

**NOTE:** Directional gain =  $3\text{dBi} + 10\log(3) = 7.8\text{dBi} > 6\text{dBi}$  , so the limit shall be reduced to  $17 - (7.8 - 6) = 15.2\text{dBm}$ .

#### 802.11n (40MHz)

CHAN.	CHAN. FREQ. (MHz)	AVERAGE POWER (dBm)			TOTAL POWER (mW)	TOTAL POWER (dBm)	POWER LIMIT (dBm)	PASS / FAIL
		CHAIN 0	CHAIN 1	CHAIN 2				
38	5190	10.26	10.22	10.24	31.7	15.01	15.2	PASS
46	5230	10.30	10.11	10.10	31.2	14.94	15.2	PASS

**NOTE:** Directional gain =  $3\text{dBi} + 10\log(3) = 7.8\text{dBi} > 6\text{dBi}$  , so the limit shall be reduced to  $17 - (7.8 - 6) = 15.2\text{dBm}$ .



**26dB BANDWIDTH: 802.11a**

CHANNEL	CHANNEL FREQUENCY (MHz)	26dBc BANDWIDTH (MHz)			PASS / FAIL
		CHAIN 0	CHAIN 1	CHAIN 2	
36	5180	24.53	24.24	23.65	PASS
40	5200	25.08	24.52	24.06	PASS
48	5240	25.57	24.61	24.10	PASS

**802.11n (20MHz)**

CHANNEL	CHANNEL FREQUENCY (MHz)	26dBc BANDWIDTH (MHz)			PASS / FAIL
		CHAIN 0	CHAIN 1	CHAIN 2	
36	5180	25.62	28.19	25.38	PASS
40	5200	26.26	26.24	24.97	PASS
48	5240	26.02	25.76	25.41	PASS

**802.11n (40MHz)**

CHANNEL	CHANNEL FREQUENCY (MHz)	26dBc BANDWIDTH (MHz)			PASS / FAIL
		CHAIN 0	CHAIN 1	CHAIN 2	
38	5190	54.94	52.29	52.11	PASS
46	5230	53.95	52.20	51.79	PASS

## 4.4 PEAK POWER SPECTRAL DENSITY MEASUREMENT

### 4.4.1 LIMITS OF PEAK POWER SPECTRAL DENSITY MEASUREMENT

FREQUENCY BAND	LIMIT
5.15 ~ 5.25GHz	4dBm

### 4.4.2 TEST SETUP

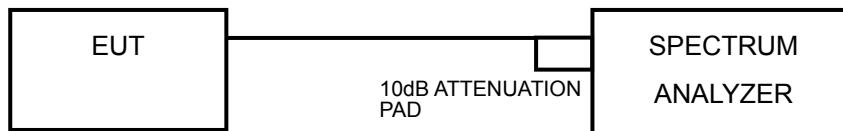

### 4.4.3 TEST INSTRUMENTS

Refer to section 4.1.3 to get information of above instrument.

### 4.4.4 TEST PROCEDURES

Using method SA-1

- 1) Set span to encompass the entire emission bandwidth (EBW) of the signal.
- 2) Set RBW = 1 MHz, Set VBW  $\geq$  3 MHz, Detector = RMS
- 3) Sweep time = auto, trigger set to "free run".
- 4) Trace average at least 100 traces in power averaging mode.
- 5) Record the max value

### 4.4.5 DEVIATION FROM TEST STANDARD

No deviation.

### 4.4.6 EUT OPERATING CONDITIONS

Same as 4.3.6.

#### 4.4.7 TEST RESULTS

##### 802.11a

CHAN.	CHAN. FREQ. (MHz)	PSD (dBm)			TOTAL POWER DENSITY (dBm)	MAX. LIMIT (dBm)	PASS / FAIL
		CHAIN 0	CHAIN 1	CHAIN 2			
36	5180	-2.97	-2.66	-2.51	2.017	2.2	PASS
40	5200	-2.76	-2.68	-2.90	1.817	2.2	PASS
48	5240	-2.12	-2.56	-2.72	2.058	2.2	PASS

- NOTE:** 1. Method 1 of power density measurement of KDB 662911 is using for calculating total power density. Total power density is summing entire spectra across corresponding frequency bins on the various outputs by computer.
2. Directional gain =  $3\text{dBi} + 10\log(3) = 7.8\text{dBi} > 6\text{dBi}$  , so the limit shall be reduced to  $4-(7.8-6) = 2.2\text{dBm}$ .

##### 802.11n (20MHz)

CHAN.	CHAN. FREQ. (MHz)	PSD (dBm)			TOTAL POWER DENSITY (dBm)	MAX. LIMIT (dBm)	PASS / FAIL
		CHAIN 0	CHAIN 1	CHAIN 2			
36	5180	-3.21	-2.74	-2.75	1.664	2.2	PASS
40	5200	-2.69	-2.98	-2.90	1.591	2.2	PASS
48	5240	-2.29	-3.12	-2.74	1.886	2.2	PASS

- NOTE:** 1. Method 1 of power density measurement of KDB 662911 is using for calculating total power density. Total power density is summing entire spectra across corresponding frequency bins on the various outputs by computer.
2. Directional gain =  $3\text{dBi} + 10\log(3) = 7.8\text{dBi} > 6\text{dBi}$  , so the limit shall be reduced to  $4-(7.8-6) = 2.2\text{dBm}$ .

##### 802.11n (40MHz)

CHAN.	CHAN. FREQ. (MHz)	PSD (dBm)			TOTAL POWER DENSITY (dBm)	MAX. LIMIT (dBm)	PASS / FAIL
		CHAIN 0	CHAIN 1	CHAIN 2			
38	5190	-3.22	-3.91	-3.59	1.092	2.2	PASS
46	5230	-2.74	-3.56	-3.83	1.241	2.2	PASS

- NOTE:** 1. Method 1 of power density measurement of KDB 662911 is using for calculating total power density. Total power density is summing entire spectra across corresponding frequency bins on the various outputs by computer.
2. Directional gain =  $3\text{dBi} + 10\log(3) = 7.8\text{dBi} > 6\text{dBi}$  , so the limit shall be reduced to  $4-(7.8-6) = 2.2\text{dBm}$ .

## 4.5 PEAK POWER EXCURSION MEASUREMENT

### 4.5.1 LIMITS OF PEAK POWER EXCURSION MEASUREMENT

Shall not exceed 13 dB

### 4.5.2 TEST SETUP

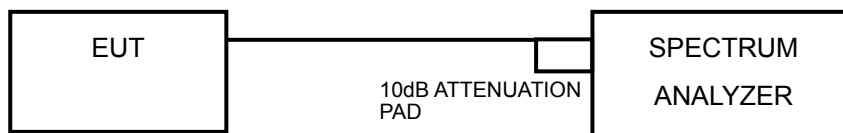

### 4.5.3 TEST INSTRUMENTS

Refer to section 4.1.3 to get information of above instrument.

### 4.5.4 TEST PROCEDURE

- 1) Set RBW = 1 MHz, VBW  $\geq$  3 MHz, Detector = peak.
- 2) Trace mode = max-hold. Allow the sweeps to continue until the trace stabilizes.
- 3) Use the peak search function to find the peak of the spectrum.
- 4) Measure the PPSD.
- 5) Compute the ratio of the maximum of the peak-max-hold spectrum to the PPSD.

### 4.5.5 DEVIATION FROM TEST STANDARD

No deviation.

### 4.5.6 EUT OPERATING CONDITIONS

Same as 4.2.6

## 4.5.7 TEST RESULTS

### 802.11a

TX chain	CHAN.	CHANNEL FREQUENCY (MHz)	PEAK VALUE (dBm)	PPSD (dBm)	PEAK EXCURSION (dB)	LIMIT (dB)	PASS /FAIL
0	36	5180	6.09	-2.97	9.06	13	PASS
	40	5200	6.15	-2.76	8.91	13	PASS
	48	5240	6.9	-2.12	9.02	13	PASS
1	36	5180	6.94	-2.66	9.60	13	PASS
	40	5200	7.11	-2.68	9.79	13	PASS
	48	5240	6.87	-2.56	9.43	13	PASS
2	36	5180	7.44	-2.51	9.95	13	PASS
	40	5200	7.81	-2.90	10.71	13	PASS
	48	5240	7.3	-2.72	10.02	13	PASS

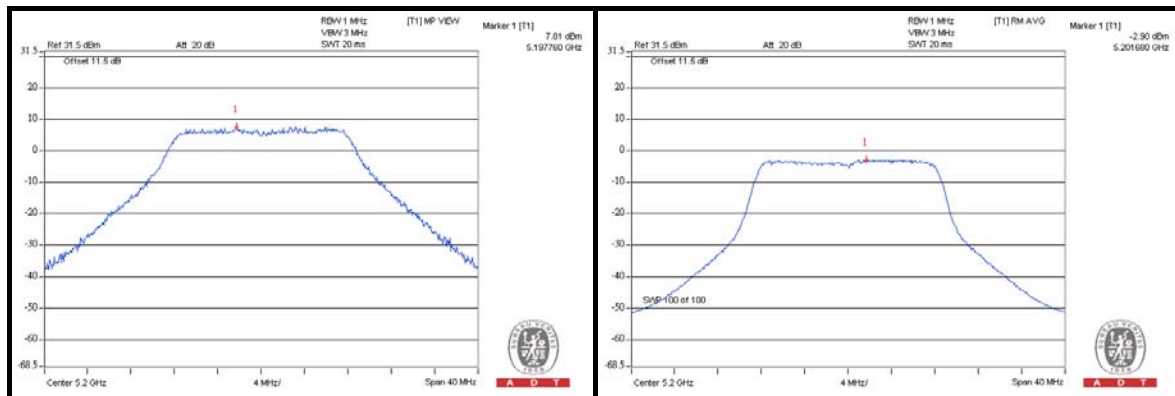



802.11n (20MHz)

TX chain	CHAN.	CHANNEL FREQUENCY (MHz)	PEAK VALUE (dBm)	PPSD (dBm)	PEAK EXCURSION (dB)	LIMIT (dB)	PASS /FAIL
0	36	5180	6.25	-3.21	9.46	13	PASS
	40	5200	6.41	-2.69	9.10	13	PASS
	48	5240	6.51	-2.29	8.80	13	PASS
1	36	5180	6.00	-2.74	8.74	13	PASS
	40	5200	6.10	-2.98	9.08	13	PASS
	48	5240	6.37	-3.12	9.49	13	PASS
2	36	5180	6.46	-2.75	9.21	13	PASS
	40	5200	6.66	-2.90	9.56	13	PASS
	48	5240	6.43	-2.74	9.17	13	PASS

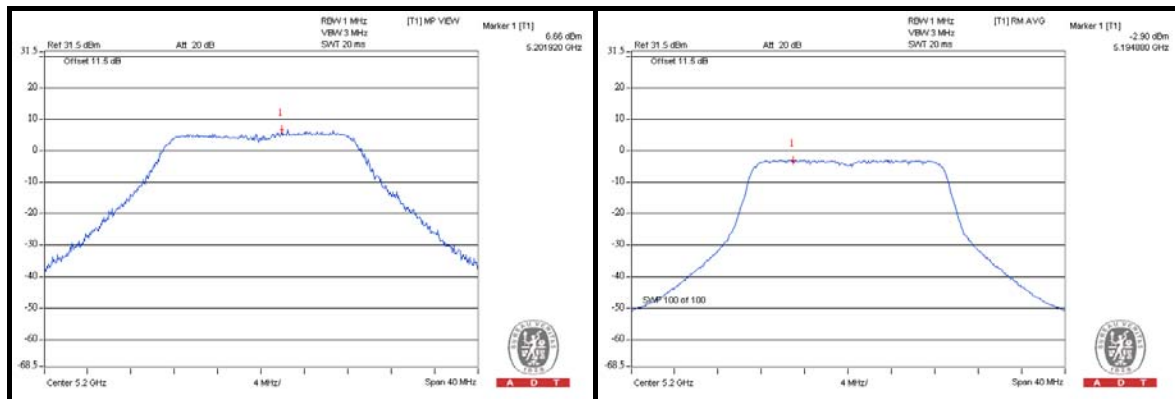



A D T

### 802.11n (40MHz)

TX chain	CHAN.	CHANNEL FREQUENCY (MHz)	PEAK VALUE (dBm)	PPSD (dBm)	PEAK EXCURSION (dB)	LIMIT (dB)	PASS /FAIL
0	38	5190	5.28	-3.22	8.50	13	PASS
	46	5230	5.70	-2.74	8.44	13	PASS
1	38	5190	6.07	-3.91	9.98	13	PASS
	46	5230	5.81	-3.56	9.37	13	PASS
2	38	5190	7.01	-3.59	10.60	13	PASS
	46	5230	6.72	-3.83	10.55	13	PASS

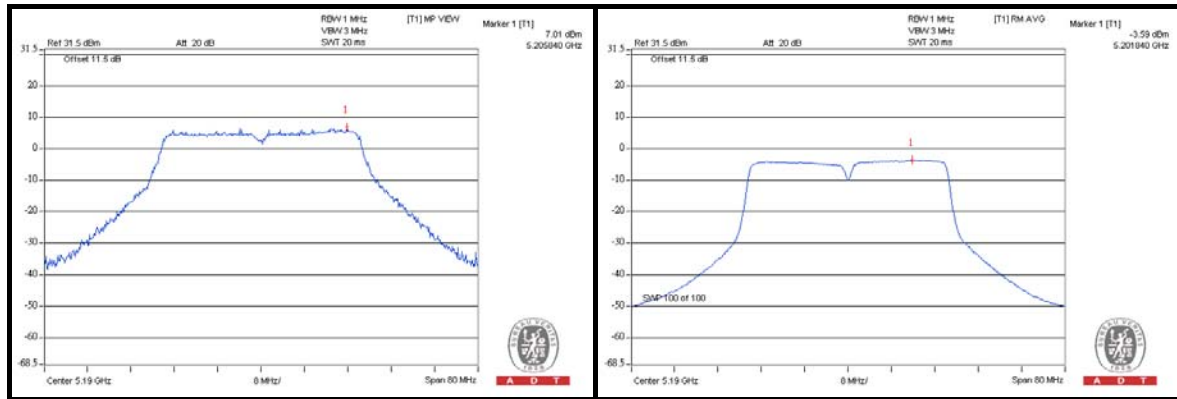



## 4.6 FREQUENCY STABILITY

### 4.6.1 LIMITS OF FREQUENCY STABILITY MEASUREMENT

The frequency of the carrier signal shall be maintained within band of operation

### 4.6.2 TEST SETUP

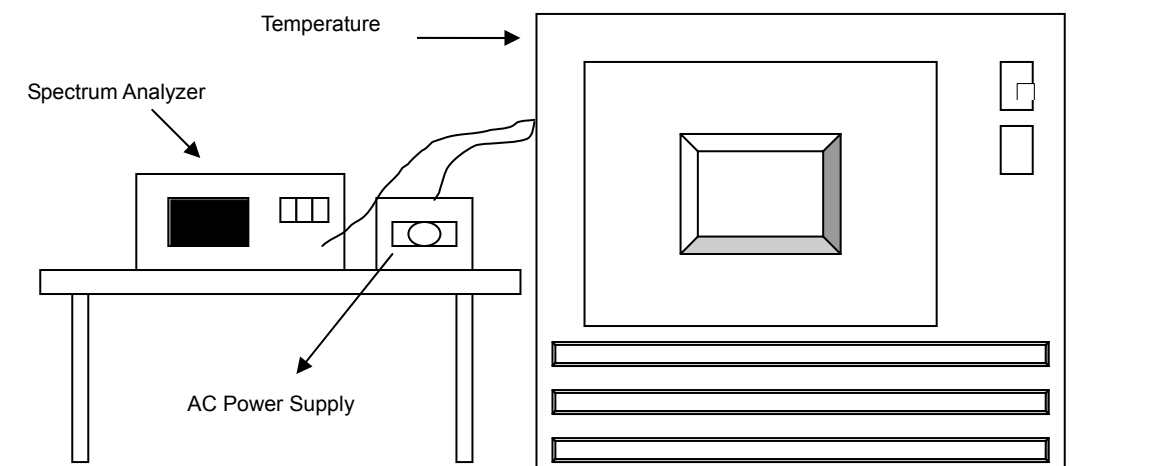

### 4.6.3 TEST INSTRUMENTS

Refer to section 4.1.3 to get information of above instrument.

#### 4.6.4 TEST PROCEDURE

- a. The EUT was placed inside the environmental test chamber and powered by nominal AC voltage.
- b. Turn the EUT on and couple its output to a spectrum analyzer.
- c. Turn the EUT off and set the chamber to the highest temperature specified.
- d. Allow sufficient time (approximately 30 min) for the temperature of the chamber to stabilize, turn the EUT on and measure the operating frequency after 2, 5, and 10 minutes.
- e. Repeat step 2 and 3 with the temperature chamber set to the lowest temperature.
- f. The test chamber was allowed to stabilize at +20 degree C for a minimum of 30 minutes. The supply voltage was then adjusted on the EUT from 85% to 115% and the frequency record.

#### 4.6.5 DEVIATION FROM TEST STANDARD

No deviation.

#### 4.6.6 EUT OPERATING CONDITION

Set the EUT transmit at un-modulation mode to test frequency stability.

#### 4.6.7 TEST RESULTS

FREQUENCY STABILITY VERSUS TEMP.									
OPERATING FREQUENCY: 5200MHz									
TEMP. (°C)	POWER SUPPLY (Vac)	0 MINUTE		2 MINUTE		5 MINUTE		10 MINUTE	
		Measured Frequency (MHz)	Frequency Drift (ppm)	Measured Frequency (MHz)	Frequency Drift (ppm)	Measured Frequency (MHz)	Frequency Drift (ppm)	Measured Frequency (MHz)	Frequency Drift (ppm)
50	110.0	5200.017603	3.385	5200.017773	3.418	5200.017514	3.368	5200.017764	3.416
40	110.0	5200.018429	3.544	5200.018269	3.513	5200.018354	3.530	5200.018439	3.546
30	110.0	5200.019786	3.805	5200.020209	3.886	5200.019895	3.826	5200.019852	3.818
20	110.0	5200.020893	4.018	5200.021051	4.048	5200.021139	4.065	5200.021047	4.048
10	110.0	5200.022600	4.346	5200.022315	4.291	5200.022349	4.298	5200.022559	4.338
0	110.0	5200.021308	4.098	5200.021402	4.116	5200.021173	4.072	5200.021350	4.106
-10	110.0	5200.019599	3.769	5200.019774	3.803	5200.020207	3.886	5200.019776	3.803
-20	110.0	5200.018793	3.614	5200.019050	3.663	5200.019465	3.743	5200.019448	3.740
-30	110.0	5200.018128	3.486	5200.018415	3.541	5200.018024	3.466	5200.018391	3.537

FREQUENCY STABILITY VERSUS VOLTAGE									
OPERATING FREQUENCY: 5200MHz									
TEMP. (°C)	POWER SUPPLY (Vac)	0 MINUTE		2 MINUTE		5 MINUTE		10 MINUTE	
		Measured Frequency (MHz)	Frequency Drift (ppm)	Measured Frequency (MHz)	Frequency Drift (ppm)	Measured Frequency (MHz)	Frequency Drift (ppm)	Measured Frequency (MHz)	Frequency Drift (ppm)
20	93.5	5200.019713	3.791	5200.019978	3.842	5200.019463	3.743	5200.019814	3.810
	110.0	5200.020893	4.018	5200.021051	4.048	5200.021139	4.065	5200.021047	4.048
	126.5	5200.022781	4.381	5200.023147	4.451	5200.023033	4.429	5200.022482	4.323

## 5. PHOTOGRAPHS OF THE TEST CONFIGURATION

Please refer to the attached file (Test Setup Photo).



## 6. INFORMATION ON THE TESTING LABORATORIES

We, Bureau Veritas Consumer Products Services (H.K.) Ltd., Taoyuan Branch, were founded in 1988 to provide our best service in EMC, Radio, Telecom and Safety consultation. Our laboratories are accredited and approved according to ISO/IEC 17025.

If you have any comments, please feel free to contact us at the following:

**Linko EMC/RF Lab:**  
Tel: 886-2-26052180  
Fax: 886-2-26051924

**Hsin Chu EMC/RF Lab:**  
Tel: 886-3-5935343  
Fax: 886-3-5935342

**Hwa Ya EMC/RF/Safety Telecom Lab:**  
Tel: 886-3-3183232  
Fax: 886-3-3270892

**Email:** [service.adt@tw.bureauveritas.com](mailto:service.adt@tw.bureauveritas.com)  
**Web Site:** [www.adt.com.tw](http://www.adt.com.tw)

The address and road map of all our labs can be found in our web site also.

## 7. APPENDIX A - MODIFICATIONS RECORDERS FOR ENGINEERING CHANGES TO THE EUT BY THE LAB

No modifications were made to the EUT by the lab during the test.

---END---