



A D T

FCC TEST REPORT (15.247)

REPORT NO.: RF111122C09

MODEL NO.: WNDA4100

FCC ID: PY311300176

RECEIVED: Nov. 22, 2011

TESTED: Nov. 22 ~ Dec. 22, 2011

ISSUED: Dec. 30, 2011

APPLICANT: NETGEAR, INC.

ADDRESS: 350 East Plumeria Drive San Jose, CA 95134

ISSUED BY: Bureau Veritas Consumer Products Services (H.K.)
Ltd., Taoyuan Branch

LAB ADDRESS: No. 47, 14th Ling, Chia Pau Vil., Lin Kou Dist., New
Taipei City, Taiwan (R.O.C)

TEST LOCATION: No. 19, Hwa Ya 2nd Rd, Wen Hwa Tsuen, Kwei
Shan Hsiang, Taoyuan Hsien 333, Taiwan, R.O.C.

This test report consists of 83 pages in total. It may be duplicated completely for legal use with the approval of the applicant. It should not be reproduced except in full, without the written approval of our laboratory. The client should not use it to claim product certification, approval or endorsement by TAF or any government agency. The test results in the report only apply to the tested sample.





TABLE OF CONTENTS

RELEASE CONTROL RECORD.....	5
1. CERTIFICATION.....	6
2. SUMMARY OF TEST RESULTS	7
2.1 MEASUREMENT UNCERTAINTY	7
3. GENERAL INFORMATION.....	8
3.1 GENERAL DESCRIPTION OF EUT.....	8
3.2 DESCRIPTION OF TEST MODES.....	10
3.2.1 CONFIGURATION OF SYSTEM UNDER TEST	11
3.2.2 TEST MODE APPLICABILITY AND TESTED CHANNEL DETAIL.....	12
3.3 GENERAL DESCRIPTION OF APPLIED STANDARDS	16
3.4 DESCRIPTION OF SUPPORT UNITS	16
4. TEST TYPES AND RESULTS (FOR 2.4GHz BAND).....	17
4.1 RADIATED EMISSION AND BANDEDGE MEASUREMENT.....	17
4.1.1 LIMITS OF RADIATED EMISSION AND BANDEDGE MEASUREMENT	17
4.1.2 TEST INSTRUMENTS	18
4.1.3 TEST PROCEDURES	19
4.1.4 DEVIATION FROM TEST STANDARD	19
4.1.5 TEST SETUP	20
4.1.6 EUT OPERATING CONDITIONS	20
4.1.7 TEST RESULTS	21
4.2 CONDUCTED EMISSION MEASUREMENT	34
4.2.1 LIMITS OF CONDUCTED EMISSION MEASUREMENT.....	34
4.2.2 TEST INSTRUMENTS	34
4.2.3 TEST PROCEDURES	35
4.2.4 DEVIATION FROM TEST STANDARD	35
4.2.5 TEST SETUP	36
4.2.6 EUT OPERATING CONDITIONS	36
4.2.7 TEST RESULTS	37
4.3 6dB BANDWIDTH MEASUREMENT	39
4.3.1 LIMITS OF 6dB BANDWIDTH MEASUREMENT	39
4.3.2 TEST SETUP	39
4.3.3 TEST INSTRUMENTS	39
4.3.4 TEST PROCEDURE	39
4.3.5 DEVIATION FROM TEST STANDARD	39
4.3.6 EUT OPERATING CONDITIONS	39
4.3.7 TEST RESULTS	40
4.4 CONDUCTED OUTPUT POWER	41
4.4.1 LIMITS OF CONDUCTED OUTPUT POWER MEASUREMENT.....	41
4.4.2 TEST SETUP	41



4.4.3	TEST INSTRUMENTS	41
4.4.4	TEST PROCEDURES	41
4.4.5	DEVIATION FROM TEST STANDARD	41
4.4.6	EUT OPERATING CONDITIONS	41
4.4.7	TEST RESULTS	42
4.5	POWER SPECTRAL DENSITY MEASUREMENT	43
4.5.1	LIMITS OF POWER SPECTRAL DENSITY MEASUREMENT	43
4.5.2	TEST SETUP	43
4.5.3	TEST INSTRUMENTS	43
4.5.4	TEST PROCEDURE	43
4.5.5	DEVIATION FROM TEST STANDARD	43
4.5.6	EUT OPERATING CONDITION	43
4.5.7	TEST RESULTS	44
4.6	CONDUCTED EMISSION MEASUREMENT	46
4.6.1	LIMITS OF BAND EDGES MEASUREMENT	46
4.6.2	TEST SETUP	46
4.6.3	TEST INSTRUMENTS	46
4.6.4	TEST PROCEDURE	46
4.6.5	DEVIATION FROM TEST STANDARD	47
4.6.6	EUT OPERATING CONDITION	47
4.6.7	TEST RESULTS	47
4.6.8	TEST RESULTS	48
5.	TEST TYPES AND RESULTS (FOR 5.0GHz BAND)	52
5.1	RADIATED EMISSION MEASUREMENT	52
5.1.1	LIMITS OF RADIATED EMISSION MEASUREMENT	52
5.1.2	TEST INSTRUMENTS	53
5.1.3	TEST PROCEDURES	54
5.1.4	DEVIATION FROM TEST STANDARD	54
5.1.5	TEST SETUP	55
5.1.6	EUT OPERATING CONDITIONS	55
5.1.7	TEST RESULTS	56
5.2	CONDUCTED EMISSION MEASUREMENT	65
5.2.1	LIMITS OF CONDUCTED EMISSION MEASUREMENT	65
5.2.2	TEST INSTRUMENTS	65
5.2.3	TEST PROCEDURES	66
5.2.4	DEVIATION FROM TEST STANDARD	66
5.2.5	TEST SETUP	67
5.2.6	EUT OPERATING CONDITIONS	67
5.2.7	TEST RESULTS	68
5.3	6dB BANDWIDTH MEASUREMENT	70
5.3.1	LIMITS OF 6dB BANDWIDTH MEASUREMENT	70



5.3.2	TEST SETUP	70
5.3.3	TEST INSTRUMENTS	70
5.3.4	TEST PROCEDURE	70
5.3.5	DEVIATION FROM TEST STANDARD	70
5.3.6	EUT OPERATING CONDITIONS	70
5.3.7	TEST RESULTS	71
5.4	CONDUCTED OUTPUT POWER	72
5.4.1	LIMITS OF CONDUCTED OUTPUT POWER MEASUREMENT	72
5.4.2	TEST SETUP	72
5.4.3	INSTRUMENTS.....	72
5.4.4	TEST PROCEDURES	72
5.4.5	DEVIATION FROM TEST STANDARD	72
5.4.6	EUT OPERATING CONDITIONS	72
5.4.7	TEST RESULTS	73
5.5	POWER SPECTRAL DENSITY MEASUREMENT.....	74
5.5.1	LIMITS OF POWER SPECTRAL DENSITY MEASUREMENT	74
5.5.2	TEST SETUP	74
5.5.3	TEST INSTRUMENTS	74
5.5.4	TEST PROCEDURE.....	74
5.5.5	DEVIATION FROM TEST STANDARD	74
5.5.6	EUT OPERATING CONDITION	74
5.5.7	TEST RESULTS	75
5.6	CONDUCTED EMISSION MEASUREMENT	76
5.6.1	LIMITS OF BAND EDGES MEASUREMENT	76
5.6.2	TEST SETUP	76
5.6.3	TEST INSTRUMENTS	76
5.6.4	TEST PROCEDURE	76
5.6.5	DEVIATION FROM TEST STANDARD	77
5.6.6	EUT OPERATING CONDITION	77
5.6.7	TEST RESULTS	77
6.	PHOTOGRAPHS OF THE TEST CONFIGURATION.....	81
7.	INFORMATION ON THE TESTING LABORATORIES	82
8.	APPENDIX A - MODIFICATIONS RECORDERS FOR ENGINEERING CHANGES TO THE EUT BY THE LAB.....	83



A D T

RELEASE CONTROL RECORD

ISSUE NO.	REASON FOR CHANGE	DATE ISSUED
Original release	N/A	Dec. 30, 2011



A D T

1. CERTIFICATION

PRODUCT: N900 Wireless Dual Band USB Adapter

MODEL: WNDA4100

BRAND: NETGEAR

APPLICANT: NETGEAR, INC.

TESTED: Nov. 22 ~ Dec. 22, 2011

TEST SAMPLE: ENGINEERING SAMPLE

STANDARDS: **FCC Part 15, Subpart C (Section 15.247)**

ANSI C63.4-2003

ANSI C63.10-2009

The above equipment (Model: WNDA4100) has been tested by **Bureau Veritas Consumer Products Services (H.K.) Ltd., Taoyuan Branch**, and found compliance with the requirement of the above standards. The test record, data evaluation & Equipment Under Test (EUT) configurations represented herein are true and accurate accounts of the measurements of the sample's EMC characteristics under the conditions specified in this report.

PREPARED BY : Ivy Lin , DATE: Dec. 30, 2011

Ivy Lin / Specialist

APPROVED BY : Gary Chang , DATE: Dec. 30, 2011

Gary Chang / Technical Manager



2. SUMMARY OF TEST RESULTS

The EUT has been tested according to the following specifications:

APPLIED STANDARD: FCC PART 15, SUBPART C (SECTION 15.247)			
STANDARD SECTION	TEST TYPE	RESULT	REMARK
15.207	AC Power Conducted Emission	PASS	Meet the requirement of limit. Minimum passing margin is -7.22dB at 0.271MHz.
15.247(d) 15.209	Radiated Emissions	PASS	Meet the requirement of limit. Minimum passing margin is -1.0dB at 2483.5MHz.
15.247(d)	Band Edge Measurement	PASS	Meet the requirement of limit.
15.247(a)(2)	6dB bandwidth	PASS	Meet the requirement of limit.
15.247(b)	Conducted power	PASS	Meet the requirement of limit.
15.247(e)	Power Spectral Density	PASS	Meet the requirement of limit.
15.203	Antenna Requirement	PASS	No antenna connector is used.

2.1 MEASUREMENT UNCERTAINTY

Where relevant, the following measurement uncertainty levels have been estimated for tests performed on the EUT as specified in CISPR 16-4-2:

MEASUREMENT	FREQUENCY	UNCERTAINTY
Conducted emissions	9kHz~30MHz	2.44 dB
Radiated emissions	30MHz ~ 200MHz	3.34 dB
	200MHz ~1000MHz	3.35 dB
	1GHz ~ 18GHz	2.26 dB
	18GHz ~ 40GHz	1.94 dB

This uncertainty represents an expanded uncertainty expressed at approximately the 95% confidence level using a coverage factor of $k = 2$.



A D T

3. GENERAL INFORMATION

3.1 GENERAL DESCRIPTION OF EUT

EUT	N900 Wireless Dual Band USB Adapter
MODEL NO.	WNDA4100
FCC ID	PY311300176
POWER SUPPLY	5Vdc (Host equipment)
MODULATION TYPE	CCK, DQPSK, DBPSK for DSSS 64QAM, 16QAM, QPSK, BPSK for OFDM
MODULATION TECHNOLOGY	DSSS, OFDM
TRANSFER RATE	802.11b: 11.0/ 5.5/ 2.0/ 1.0Mbps 802.11g: 54.0/ 48.0/ 36.0/ 24.0/ 18.0/ 12.0/ 9.0/ 6.0Mbps 802.11a: 54.0/ 48.0/ 36.0/ 24.0/ 18.0/ 12.0/ 9.0/ 6.0Mbps 802.11n: up to 450.0Mbps
OPERATING FREQUENCY	2.4GHz: 2412 ~ 2462MHz 5.0GHz: 5745 ~ 5825MHz
NUMBER OF CHANNEL	2.4GHz: 11 for 802.11b, 802.11g, 802.11n (20MHz) 7 for 802.11n (40MHz) 5.0GHz: 5 for 802.11a, 802.11n (20MHz) 2 for 802.11n (40MHz)
OUTPUT POWER	765.5mW for 2412 ~ 2462MHz 440.8mW for 5745 ~ 5825MHz
ANTENNA TYPE	2.4GHz: PIFA antenna with 2.0dBi gain 5.0GHz: PIFA antenna with 3.0dBi gain
ANTENNA CONNECTOR	NA
DATA CABLE	1.0m shielded USB cable without core (for Cradle)
I/O PORTS	USB
ACCESSORY DEVICES	Cradle

NOTE:

1. The frequency bands used in this EUT are listed as follows:

Frequency Band (MHz)	2412~2462	5180~5320	5500~5700	5745~5825
802.11b	√			
802.11g	√			
802.11a		√	√	√
802.11n (20MHz)	√	√	√	√
802.11n (40MHz)	√	√	√	√

2. The EUT incorporates a MIMO function. Physically, the EUT provides three completed transmitters and three receivers.

MODULATION MODE	TX FUNCTION
802.11b	1TX
802.11g	1TX
802.11a	1TX
802.11n (20MHz)	3TX
802.11n (40MHz)	3TX

3. After pre-testing, the EUT with cradle is the worst case for final test.
4. The above EUT information is declared by manufacturer and for more detailed features description, please refer to the manufacturer's specifications or user's manual.

3.2 DESCRIPTION OF TEST MODES

FOR 2.4GHz:

11 channels are provided for 802.11b, 802.11g and 802.11n (20MHz):

CHANNEL	FREQUENCY	CHANNEL	FREQUENCY
1	2412MHz	7	2442MHz
2	2417MHz	8	2447MHz
3	2422MHz	9	2452MHz
4	2427MHz	10	2457MHz
5	2432MHz	11	2462MHz
6	2437MHz		

7 channels are provided for 802.11n (40MHz):

CHANNEL	FREQUENCY	CHANNEL	FREQUENCY
1	2422MHz	5	2442MHz
2	2427MHz	6	2447MHz
3	2432MHz	7	2452MHz
4	2437MHz		

FOR 5.0GHz (5745 ~ 5825MHz):

5 channels are provided for 802.11a, 802.11n (20MHz):

CHANNEL	FREQUENCY	CHANNEL	FREQUENCY
149	5745MHz	161	5805MHz
153	5765MHz	165	5825MHz
157	5785MHz		

2 channels are provided for 802.11n (40MHz):

CHANNEL	FREQUENCY	CHANNEL	FREQUENCY
151	5755MHz	159	5795MHz

3.2.1 CONFIGURATION OF SYSTEM UNDER TEST

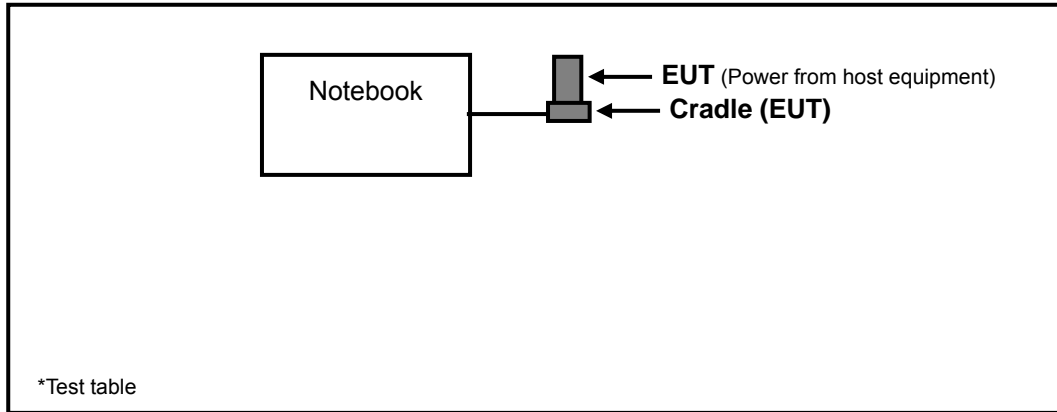



3.2.2 TEST MODE APPLICABILITY AND TESTED CHANNEL DETAIL

FOR 2.4GHz:

EUT CONFIGURE MODE	APPLICABLE TO				DESCRIPTION
	RE \geq 1G	RE<1G	PLC	APCM	
-	√	√	√	√	The EUT with cradle

Where **RE \geq 1G:** Radiated Emission above 1GHz **RE<1G:** Radiated Emission below 1GHz
PLC: Power Line Conducted Emission **APCM:** Antenna Port Conducted Measurement

RADIATED EMISSION TEST (ABOVE 1GHz):

- Pre-Scan has been conducted to determine the worst-case mode from all possible combinations between available modulations, data rates and antenna ports (if EUT with antenna diversity architecture).
- Following channel(s) was (were) selected for the final test as listed below.

EUT CONFIGURE MODE	MODE	AVAILABLE CHANNEL	TESTED CHANNEL	MODULATION TECHNOLOGY	MODULATION TYPE	DATA RATE (Mbps)
-	802.11b	1 to 11	1, 6, 11	DSSS	DBPSK	1.0
-	802.11g	1 to 11	1, 6, 11	OFDM	BPSK	6.0
-	802.11n (20MHz)	1 to 11	1, 6, 11	OFDM	BPSK	7.2
-	802.11n (40MHz)	1 to 7	1, 4, 7	OFDM	BPSK	15.0

RADIATED EMISSION TEST (BELOW 1GHz):

- Pre-Scan has been conducted to determine the worst-case mode from all possible combinations between available modulations, data rates and antenna ports (if EUT with antenna diversity architecture).
- Following channel(s) was (were) selected for the final test as listed below.

EUT CONFIGURE MODE	MODE	AVAILABLE CHANNEL	TESTED CHANNEL	MODULATION TECHNOLOGY	MODULATION TYPE	DATA RATE (Mbps)
-	802.11n (20MHz)	1 to 7	6	OFDM	BPSK	7.2

POWER LINE CONDUCTED EMISSION TEST:

- Pre-Scan has been conducted to determine the worst-case mode from all possible combinations between available modulations, data rates and antenna ports (if EUT with antenna diversity architecture).
- Following channel(s) was (were) selected for the final test as listed below.

EUT CONFIGURE MODE	MODE	AVAILABLE CHANNEL	TESTED CHANNEL	MODULATION TECHNOLOGY	MODULATION TYPE	DATA RATE (Mbps)
-	802.11n (20MHz)	1 to 7	6	OFDM	BPSK	7.2



BANDEDGE MEASUREMENT:

- Pre-Scan has been conducted to determine the worst-case mode from all possible combinations between available modulations, data rates and antenna ports (if EUT with antenna diversity architecture).
- Following channel(s) was (were) selected for the final test as listed below.

EUT CONFIGURE MODE	MODE	AVAILABLE CHANNEL	TESTED CHANNEL	MODULATION TECHNOLOGY	MODULATION TYPE	DATA RATE (Mbps)
-	802.11b	1 to 11	1, 11	DSSS	DBPSK	1.0
-	802.11g	1 to 11	1, 11	OFDM	BPSK	6.0
-	802.11n (20MHz)	1 to 11	1, 11	OFDM	BPSK	7.2
-	802.11n (40MHz)	1 to 7	1, 7	OFDM	BPSK	15.0

ANTENNA PORT CONDUCTED MEASUREMENT:

- This item includes all test value of each mode, but only includes spectrum plot of worst value of each mode.
- Pre-Scan has been conducted to determine the worst-case mode from all possible combinations between available modulations, data rates and antenna ports (if EUT with antenna diversity architecture).
- Following channel(s) was (were) selected for the final test as listed below.

EUT CONFIGURE MODE	MODE	AVAILABLE CHANNEL	TESTED CHANNEL	MODULATION TECHNOLOGY	MODULATION TYPE	DATA RATE (Mbps)
-	802.11b	1 to 11	1, 6, 11	DSSS	DBPSK	1.0
-	802.11g	1 to 11	1, 6, 11	OFDM	BPSK	6.0
-	802.11n (20MHz)	1 to 11	1, 6, 11	OFDM	BPSK	7.2
-	802.11n (40MHz)	1 to 7	1, 4, 7	OFDM	BPSK	15.0

TEST CONDITION:

APPLICABLE TO	ENVIRONMENTAL CONDITIONS	INPUT POWER	TESTED BY
RE≥1G	25deg. C, 65%RH	120Vac, 60Hz	Long Chen, David Huang
RE<1G	25deg. C, 65%RH	120Vac, 60Hz	Kay Wu
PLC	26deg. C, 65%RH	120Vac, 60Hz	Antony Lee
APCM	25deg. C, 65%RH	120Vac, 60Hz	Kay Wu



FOR 5.745 ~ 5.825GHz:

EUT CONFIGURE MODE	APPLICABLE TO				DESCRIPTION
	RE≥1G	RE<1G	PLC	APCM	
-	√	√	√	√	The EUT with cradle

Where **PLC:** Power Line Conducted Emission **RE<1G:** Radiated Emission below 1GHz
RE≥1G: Radiated Emission above 1GHz **APCM:** Antenna Port Conducted Measurement

RADIATED EMISSION TEST (ABOVE 1GHz):

- Pre-Scan has been conducted to determine the worst-case mode from all possible combinations between available modulations, data rates and antenna ports (if EUT with antenna diversity architecture).
- Following channel(s) was (were) selected for the final test as listed below.

EUT CONFIGURE MODE	MODE	AVAILABLE CHANNEL	TESTED CHANNEL	MODULATION TECHNOLOGY	MODULATION TYPE	DATA RATE (Mbps)
-	802.11a	149 to 165	149, 157, 165	OFDM	BPSK	6.0
-	802.11n (20MHz)	149 to 165	149, 157, 165	OFDM	BPSK	7.2
-	802.11n (40MHz)	151 to 159	151, 159	OFDM	BPSK	15.0

RADIATED EMISSION TEST (BELOW 1GHz):

- Pre-Scan has been conducted to determine the worst-case mode from all possible combinations between available modulations, data rates and antenna ports (if EUT with antenna diversity architecture).
- Following channel(s) was (were) selected for the final test as listed below.

EUT CONFIGURE MODE	MODE	AVAILABLE CHANNEL	TESTED CHANNEL	MODULATION TECHNOLOGY	MODULATION TYPE	DATA RATE (Mbps)
-	802.11n (20MHz)	149 to 165	157	OFDM	BPSK	7.2

POWER LINE CONDUCTED EMISSION TEST:

- Pre-Scan has been conducted to determine the worst-case mode from all possible combinations between available modulations, data rates and antenna ports (if EUT with antenna diversity architecture).
- Following channel(s) was (were) selected for the final test as listed below.

EUT CONFIGURE MODE	MODE	AVAILABLE CHANNEL	TESTED CHANNEL	MODULATION TECHNOLOGY	MODULATION TYPE	DATA RATE (Mbps)
-	802.11n (20MHz)	149 to 165	157	OFDM	BPSK	7.2



A D T

BANDEDGE MEASUREMENT:

- Pre-Scan has been conducted to determine the worst-case mode from all possible combinations between available modulations, data rates and antenna ports (if EUT with antenna diversity architecture).
- Following channel(s) was (were) selected for the final test as listed below.

EUT CONFIGURE MODE	MODE	AVAILABLE CHANNEL	TESTED CHANNEL	MODULATION TECHNOLOGY	MODULATION TYPE	DATA RATE (Mbps)
-	802.11a	149 to 165	149, 165	OFDM	BPSK	6.0
-	802.11n (20MHz)	149 to 165	149, 165	OFDM	BPSK	7.2
-	802.11n (40MHz)	151 to 159	151, 159	OFDM	BPSK	15.0

ANTENNA PORT CONDUCTED MEASUREMENT:

- This item includes all test value of each mode, but only includes spectrum plot of worst value of each mode.
- Pre-Scan has been conducted to determine the worst-case mode from all possible combinations between available modulations, data rates and antenna ports (if EUT with antenna diversity architecture).
- Following channel(s) was (were) selected for the final test as listed below.

EUT CONFIGURE MODE	MODE	AVAILABLE CHANNEL	TESTED CHANNEL	MODULATION TECHNOLOGY	MODULATION TYPE	DATA RATE (Mbps)
-	802.11a	149 to 165	149, 157, 165	OFDM	BPSK	6.0
-	802.11n (20MHz)	149 to 165	149, 157, 165	OFDM	BPSK	7.2
-	802.11n (40MHz)	151 to 159	151, 159	OFDM	BPSK	15.0

TEST CONDITION:

APPLICABLE TO	ENVIRONMENTAL CONDITIONS	INPUT POWER	TESTED BY
RE≥1G	25deg. C, 65%RH	120Vac, 60Hz	David Huang, Kay Wu
RE<1G	25deg. C, 65%RH	120Vac, 60Hz	Kay Wu
PLC	26deg. C, 65%RH	120Vac, 60Hz	Antony Lee
APCM	25deg. C, 65%RH	120Vac, 60Hz	Kay Wu



A D T

3.3 GENERAL DESCRIPTION OF APPLIED STANDARDS

The EUT is a RF Product. According to the specifications of the manufacturer, it must comply with the requirements of the following standards:

FCC Part 15, Subpart C (15.247)

ANSI C63.4-2003

ANSI C63.10-2009

All test items have been performed and recorded as per the above standards.

NOTE: The EUT is also considered as a kind of computer peripheral, because the connection to computer is necessary for typical use. It has been verified to comply with the requirements of FCC Part 15, Subpart B, Class B (DoC). The test report has been issued separately.

3.4 DESCRIPTION OF SUPPORT UNITS

The EUT has been tested as an independent unit together with other necessary accessories or support units. The following support units or accessories were used to form a representative test configuration during the tests.

NO.	PRODUCT	BRAND	MODEL NO.	SERIAL NO.	FCC ID
1	NOTEBOOK	DELL	E5420	NA	NA

NO.	SIGNAL CABLE DESCRIPTION OF THE ABOVE SUPPORT UNITS
1	1 NA

NOTE: All power cords of the above support units are non shielded (1.8m).



4. TEST TYPES AND RESULTS (FOR 2.4GHz BAND)

4.1 RADIATED EMISSION AND BANDEDGE MEASUREMENT

4.1.1 LIMITS OF RADIATED EMISSION AND BANDEDGE MEASUREMENT

Radiated emissions which fall in the restricted bands, as defined in Section 15.205(a), must also comply with the radiated emission limits specified in Section 15.209(a). Other emissions shall be at least 20dB below the highest level of the desired power.

FREQUENCIES (MHz)	FIELD STRENGTH (microvolts/meter)	MEASUREMENT DISTANCE (meters)
0.009 ~ 0.490	2400/F(kHz)	300
0.490 ~ 1.705	24000/F(kHz)	30
1.705 ~ 30.0	30	30
30 ~ 88	100	3
88 ~ 216	150	3
216 ~ 960	200	3
Above 960	500	3

NOTE:

1. The lower limit shall apply at the transition frequencies.
2. Emission level (dBuV/m) = 20 log Emission level (uV/m).
3. As shown in 15.35(b), for frequencies above 1000MHz, the field strength limits are based on average detector, however, the peak field strength of any emission shall not exceed the maximum permitted average limits, specified above by more than 20dB under any condition of modulation.



A D T

4.1.2 TEST INSTRUMENTS

DESCRIPTION & MANUFACTURER	MODEL NO.	SERIAL NO.	DATE OF CALIBRATION	DUE DATE OF CALIBRATION
Test Receiver ROHDE & SCHWARZ	ESIB7	100212	Aug. 02, 2011	Aug. 01, 2012
Spectrum Analyzer ROHDE & SCHWARZ	FSP40	100041	Jul. 21, 2011	Jul. 20, 2012
BILOG Antenna SCHWARZBECK	VULB9168	9168-160	Apr. 13, 2011	Apr. 12, 2012
HORN Antenna SCHWARZBECK	9120D	209	Aug. 25, 2011	Aug. 24, 2012
HORN Antenna SCHWARZBECK	BBHA 9170	148	Jul. 20, 2011	Jul. 19, 2012
Preamplifier Agilent	8447D	2944A10633	Oct. 29, 2011	Oct. 28, 2012
Preamplifier Agilent	8449B	3008A01964	Oct. 29, 2011	Oct. 28, 2012
RF signal cable HUBER+SUHNNER	SUCOFLEX 104	250723/4	Aug. 30, 2011	Aug. 29, 2012
RF signal cable HUBER+SUHNNER	SUCOFLEX 106	12738/6+309224/ 4	Aug. 30, 2011	Aug. 29, 2012
Software ADT.	ADT_Radiated_ V7.6.15.9.2	NA	NA	NA
Antenna Tower inn-co GmbH	MA 4000	013303	NA	NA
Antenna Tower Controller inn-co GmbH	CO2000	017303	NA	NA
Turn Table ADT.	TT100.	TT93021703	NA	NA
Turn Table Controller ADT.	SC100.	SC93021703	NA	NA
High Speed Peak Power Meter	ML2495A	0842014	Apr. 26, 2011	Apr. 25, 2012
Power Sensor	MA2411B	0738404	Apr. 26, 2011	Apr. 25, 2012

- NOTE:**
1. The calibration interval of the above test instruments is 12 months and the calibrations are traceable to NML/ROC and NIST/USA.
 2. The test was performed in HwaYa Chamber 3.
 3. The horn antenna and HP preamplifier (model: 8449B) are used only for the measurement of emission frequency above 1GHz if tested.
 4. The FCC Site Registration No. is 988962.
 5. The IC Site Registration No. is IC 7450F-3.



4.1.3 TEST PROCEDURES

- a. The EUT was placed on the top of a rotating table 0.8 meters above the ground at a 3 meters semi-anechoic chamber. The table was rotated 360 degrees to determine the position of the highest radiation.
- b. The EUT was set 3 meters away from the interference-receiving antenna, which was mounted on the top of a variable-height antenna tower.
- c. The antenna is a broadband antenna, and its height is varied from one meter to four meters above the ground to determine the maximum value of the field strength. Both horizontal and vertical polarizations of the antenna are set to make the measurement.
- d. For each suspected emission, the EUT was arranged to its worst case and then the antenna was tuned to heights from 1 meter to 4 meters and the rotatable table was turned from 0 degrees to 360 degrees to find the maximum reading.
- e. The test-receiver system was set to Peak Detect Function and Specified Bandwidth with Maximum Hold Mode.
- f. If the emission level of the EUT in peak mode was lower than the limit specified, then testing could be stopped and the peak values of the EUT would be reported. Otherwise the emissions would be re-tested one by one using peak, quasi-peak or average method as specified and then reported in a data sheet.

NOTE:

1. The resolution bandwidth and video bandwidth of test receiver/spectrum analyzer is 120kHz for Quasi-peak detection at frequency below 1GHz.
2. The resolution bandwidth of test receiver/spectrum analyzer is 100kHz and video bandwidth is 300kHz for Peak detection at frequency above 1GHz.
3. The resolution bandwidth of test receiver/spectrum analyzer is 1MHz and the video bandwidth is 1kHz for Average detection (AV) at frequency above 1GHz.
4. All modes of operation were investigated and the worst-case emissions are reported.

4.1.4 DEVIATION FROM TEST STANDARD

No deviation.

4.1.5 TEST SETUP

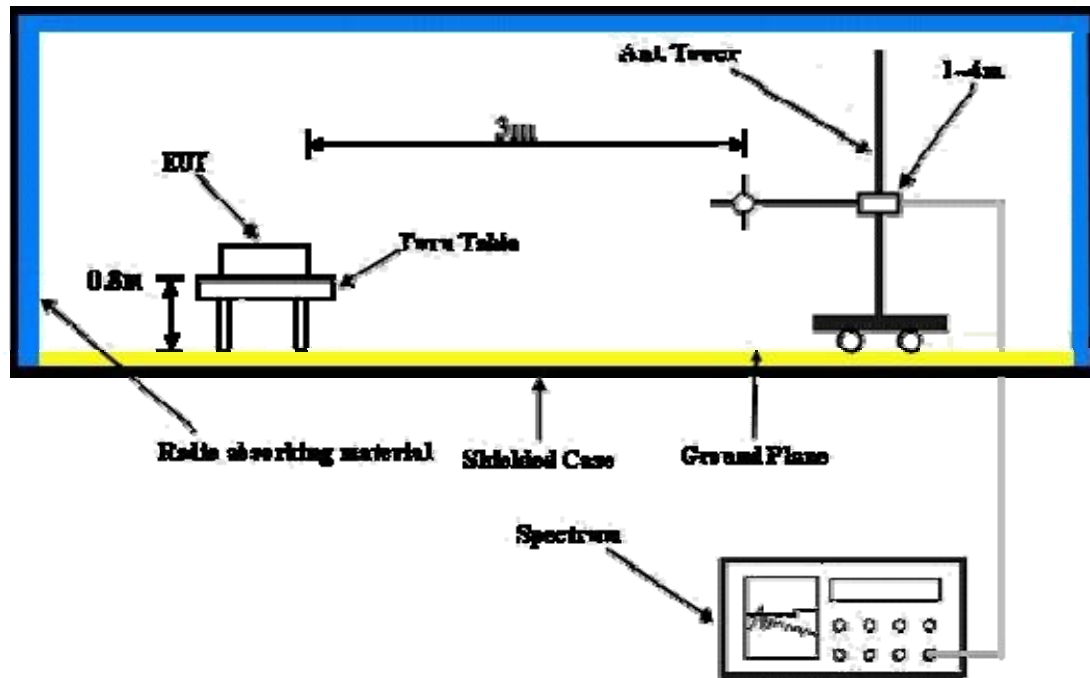

For the actual test configuration, please refer to the attached file (Test Setup Photo).

4.1.6 EUT OPERATING CONDITIONS

- a. Connected EUT to a notebook system with USB cable and placed on a testing table.
- b. The notebook ran a test program (provided by manufacturer) to enable EUT under transmission condition continuously at specific channel frequency.
- c. The necessary accessories enable the system in full functions.



A D T

4.1.7 TEST RESULTS

802.11b

EUT TEST CONDITION		MEASUREMENT DETAIL	
CHANNEL	Channel 1	FREQUENCY RANGE	1 ~ 25GHz
INPUT POWER (SYSTEM)	120Vac, 60Hz	DETECTOR FUNCTION	Peak (PK) Average (AV)
ENVIRONMENTAL CONDITIONS	25deg. C, 65%RH	TESTED BY	David Huang

ANTENNA POLARITY & TEST DISTANCE: HORIZONTAL AT 3 M								
NO.	FREQ. (MHz)	EMISSION LEVEL (dBuV/m)	LIMIT (dBuV/m)	MARGIN (dB)	ANTENNA HEIGHT (m)	TABLE ANGLE (Degree)	RAW VALUE (dBuV)	CORRECTION FACTOR (dB/m)
1	2386.00	58.4 PK	74.0	-15.6	1.02 H	210	27.30	31.10
2	2386.00	48.5 AV	54.0	-5.5	1.02 H	210	17.40	31.10
3	2390.00	57.7 PK	74.0	-16.3	1.02 H	210	26.60	31.10
4	2390.00	52.5 AV	54.0	-1.5	1.02 H	210	21.40	31.10
5	*2412.00	107.0 PK			1.03 H	211	75.80	31.20
6	*2412.00	103.2 AV			1.03 H	211	72.00	31.20
7	4824.00	43.7 PK	74.0	-30.3	1.00 H	314	6.80	36.90
8	4824.00	33.2 AV	54.0	-20.8	1.00 H	314	-3.70	36.90
ANTENNA POLARITY & TEST DISTANCE: VERTICAL AT 3 M								
NO.	FREQ. (MHz)	EMISSION LEVEL (dBuV/m)	LIMIT (dBuV/m)	MARGIN (dB)	ANTENNA HEIGHT (m)	TABLE ANGLE (Degree)	RAW VALUE (dBuV)	CORRECTION FACTOR (dB/m)
1	2386.00	61.1 PK	74.0	-12.9	1.53 V	259	30.00	31.10
2	2386.00	50.7 AV	54.0	-3.3	1.53 V	259	19.60	31.10
3	*2412.00	100.4 PK			1.84 V	262	69.20	31.20
4	*2412.00	96.7 AV			1.84 V	262	65.50	31.20
5	4824.00	44.1 PK	74.0	-29.9	1.00 V	81	7.20	36.90
6	4824.00	31.0 AV	54.0	-23.0	1.00 V	81	-5.90	36.90

- REMARKS:**
1. Emission level (dBuV/m) = Raw Value (dBuV) + Correction Factor (dB/m).
 2. Correction Factor (dB/m) = Antenna Factor (dB/m) + Cable Factor (dB).
 3. The other emission levels were very low against the limit.
 4. Margin value = Emission level – Limit value.
 5. “ * “: Fundamental frequency.



A D T

EUT TEST CONDITION		MEASUREMENT DETAIL	
CHANNEL	Channel 6	FREQUENCY RANGE	1 ~ 25GHz
INPUT POWER (SYSTEM)	120Vac, 60Hz	DETECTOR FUNCTION	Peak (PK) Average (AV)
ENVIRONMENTAL CONDITIONS	25deg. C, 65%RH	TESTED BY	David Huang

ANTENNA POLARITY & TEST DISTANCE: HORIZONTAL AT 3 M								
NO.	FREQ. (MHz)	EMISSION LEVEL (dBuV/m)	LIMIT (dBuV/m)	MARGIN (dB)	ANTENNA HEIGHT (m)	TABLE ANGLE (Degree)	RAW VALUE (dBuV)	CORRECTION FACTOR (dB/m)
1	2390.00	56.6 PK	74.0	-17.4	1.00 H	207	25.50	31.10
2	2390.00	47.5 AV	54.0	-6.5	1.00 H	207	16.40	31.10
3	*2437.00	106.2 PK			1.00 H	207	74.90	31.30
4	*2437.00	102.5 AV			1.00 H	207	71.20	31.30
5	4874.00	42.7 PK	74.0	-31.3	1.00 H	150	5.70	37.00
6	4874.00	30.6 AV	54.0	-23.4	1.00 H	150	-6.40	37.00
ANTENNA POLARITY & TEST DISTANCE: VERTICAL AT 3 M								
NO.	FREQ. (MHz)	EMISSION LEVEL (dBuV/m)	LIMIT (dBuV/m)	MARGIN (dB)	ANTENNA HEIGHT (m)	TABLE ANGLE (Degree)	RAW VALUE (dBuV)	CORRECTION FACTOR (dB/m)
1	2390.00	55.5 PK	74.0	-18.5	1.00 V	218	24.40	31.10
2	2390.00	44.6 AV	54.0	-9.4	1.00 V	218	13.50	31.10
3	*2437.00	99.0 PK			1.00 V	196	67.70	31.30
4	*2437.00	95.3 AV			1.00 V	196	64.00	31.30
5	4874.00	43.9 PK	74.0	-30.1	1.00 V	193	6.90	37.00
6	4874.00	31.0 AV	54.0	-23.0	1.00 V	193	-6.00	37.00

- REMARKS:**
1. Emission level (dBuV/m) = Raw Value (dBuV) + Correction Factor (dB/m).
 2. Correction Factor (dB/m) = Antenna Factor (dB/m) + Cable Factor (dB).
 3. The other emission levels were very low against the limit.
 4. Margin value = Emission level – Limit value.
 5. “ * “: Fundamental frequency.



A D T

EUT TEST CONDITION		MEASUREMENT DETAIL	
CHANNEL	Channel 11	FREQUENCY RANGE	1 ~ 25GHz
INPUT POWER (SYSTEM)	120Vac, 60Hz	DETECTOR FUNCTION	Peak (PK) Average (AV)
ENVIRONMENTAL CONDITIONS	25deg. C, 65%RH	TESTED BY	David Huang

ANTENNA POLARITY & TEST DISTANCE: HORIZONTAL AT 3 M								
NO.	FREQ. (MHz)	EMISSION LEVEL (dBuV/m)	LIMIT (dBuV/m)	MARGIN (dB)	ANTENNA HEIGHT (m)	TABLE ANGLE (Degree)	RAW VALUE (dBuV)	CORRECTION FACTOR (dB/m)
1	*2462.00	105.1 PK			1.25 H	223	73.70	31.40
2	*2462.00	101.3 AV			1.25 H	223	69.90	31.40
3	2483.50	56.9 PK	74.0	-17.1	1.00 H	207	25.50	31.40
4	2483.50	48.2 AV	54.0	-5.8	1.00 H	207	16.80	31.40
5	4924.00	43.6 PK	74.0	-30.4	1.00 H	237	6.50	37.10
6	4924.00	30.7 AV	54.0	-23.3	1.00 H	237	-6.40	37.10
ANTENNA POLARITY & TEST DISTANCE: VERTICAL AT 3 M								
NO.	FREQ. (MHz)	EMISSION LEVEL (dBuV/m)	LIMIT (dBuV/m)	MARGIN (dB)	ANTENNA HEIGHT (m)	TABLE ANGLE (Degree)	RAW VALUE (dBuV)	CORRECTION FACTOR (dB/m)
1	*2462.00	99.6 PK			1.18 V	259	68.20	31.40
2	*2462.00	95.9 AV			1.18 V	259	64.50	31.40
3	2483.50	55.0 PK	74.0	-19.0	1.00 V	252	23.60	31.40
4	2483.50	44.9 AV	54.0	-9.1	1.00 V	252	13.50	31.40
5	4824.00	44.0 PK	74.0	-30.0	1.00 V	188	7.10	36.90
6	4824.00	30.2 AV	54.0	-23.8	1.00 V	188	-6.70	36.90

- REMARKS:**
1. Emission level (dBuV/m) = Raw Value (dBuV) + Correction Factor (dB/m).
 2. Correction Factor (dB/m) = Antenna Factor (dB/m) + Cable Factor (dB).
 3. The other emission levels were very low against the limit.
 4. Margin value = Emission level – Limit value.
 5. “ * “: Fundamental frequency.



A D T

802.11g

EUT TEST CONDITION		MEASUREMENT DETAIL	
CHANNEL	Channel 1	FREQUENCY RANGE	1 ~ 25GHz
INPUT POWER (SYSTEM)	120Vac, 60Hz	DETECTOR FUNCTION	Peak (PK) Average (AV)
ENVIRONMENTAL CONDITIONS	25deg. C, 65%RH	TESTED BY	David Huang

ANTENNA POLARITY & TEST DISTANCE: HORIZONTAL AT 3 M								
NO.	FREQ. (MHz)	EMISSION LEVEL (dBuV/m)	LIMIT (dBuV/m)	MARGIN (dB)	ANTENNA HEIGHT (m)	TABLE ANGLE (Degree)	RAW VALUE (dBuV)	CORRECTION FACTOR (dB/m)
1	2390.00	67.8 PK	74.0	-6.2	1.31 H	214	36.70	31.10
2	2390.00	52.6 AV	54.0	-1.4	1.31 H	214	21.50	31.10
3	*2412.00	108.2 PK			1.02 H	210	77.00	31.20
4	*2412.00	98.2 AV			1.02 H	210	67.00	31.20
5	4824.00	41.7 PK	74.0	-32.3	1.00 H	201	4.80	36.90
6	4824.00	31.0 AV	54.0	-23.0	1.00 H	201	-5.90	36.90
ANTENNA POLARITY & TEST DISTANCE: VERTICAL AT 3 M								
NO.	FREQ. (MHz)	EMISSION LEVEL (dBuV/m)	LIMIT (dBuV/m)	MARGIN (dB)	ANTENNA HEIGHT (m)	TABLE ANGLE (Degree)	RAW VALUE (dBuV)	CORRECTION FACTOR (dB/m)
1	2390.00	61.2 PK	74.0	-12.8	1.00 V	139	30.10	31.10
2	2390.00	47.0 AV	54.0	-7.0	1.00 V	139	15.90	31.10
3	*2412.00	100.7 PK			1.00 V	136	69.50	31.20
4	*2412.00	90.8 AV			1.00 V	136	59.60	31.20
5	4824.00	44.0 PK	74.0	-30.0	1.00 V	90	7.10	36.90
6	4824.00	30.6 AV	54.0	-23.4	1.00 V	90	-6.30	36.90

- REMARKS:**
1. Emission level (dBuV/m) = Raw Value (dBuV) + Correction Factor (dB/m).
 2. Correction Factor (dB/m) = Antenna Factor (dB/m) + Cable Factor (dB).
 3. The other emission levels were very low against the limit.
 4. Margin value = Emission level – Limit value.
 5. “ * “: Fundamental frequency.



A D T

EUT TEST CONDITION		MEASUREMENT DETAIL	
CHANNEL	Channel 6	FREQUENCY RANGE	1 ~ 25GHz
INPUT POWER (SYSTEM)	120Vac, 60Hz	DETECTOR FUNCTION	Peak (PK) Average (AV)
ENVIRONMENTAL CONDITIONS	25deg. C, 65%RH	TESTED BY	David Huang

ANTENNA POLARITY & TEST DISTANCE: HORIZONTAL AT 3 M								
NO.	FREQ. (MHz)	EMISSION LEVEL (dBuV/m)	LIMIT (dBuV/m)	MARGIN (dB)	ANTENNA HEIGHT (m)	TABLE ANGLE (Degree)	RAW VALUE (dBuV)	CORRECTION FACTOR (dB/m)
1	2390.00	60.7 PK	74.0	-13.3	1.30 H	216	29.60	31.10
2	2390.00	50.2 AV	54.0	-3.8	1.30 H	216	19.10	31.10
3	*2437.00	109.0 PK			1.02 H	211	77.70	31.30
4	*2437.00	98.6 AV			1.02 H	211	67.30	31.30
5	4874.00	43.8 PK	74.0	-30.2	1.00 H	232	6.80	37.00
6	4874.00	30.8 AV	54.0	-23.2	1.00 H	232	-6.20	37.00
ANTENNA POLARITY & TEST DISTANCE: VERTICAL AT 3 M								
NO.	FREQ. (MHz)	EMISSION LEVEL (dBuV/m)	LIMIT (dBuV/m)	MARGIN (dB)	ANTENNA HEIGHT (m)	TABLE ANGLE (Degree)	RAW VALUE (dBuV)	CORRECTION FACTOR (dB/m)
1	2390.00	58.2 PK	74.0	-15.8	1.53 V	258	27.10	31.10
2	2390.00	48.4 AV	54.0	-5.6	1.53 V	258	17.30	31.10
3	*2437.00	103.3 PK			1.48 V	259	72.00	31.30
4	*2437.00	93.3 AV			1.48 V	259	62.00	31.30
5	4874.00	44.0 PK	74.0	-30.0	1.00 V	260	7.00	37.00
6	4874.00	30.9 AV	54.0	-23.1	1.00 V	260	-6.10	37.00

- REMARKS:**
1. Emission level (dBuV/m) = Raw Value (dBuV) + Correction Factor (dB/m).
 2. Correction Factor (dB/m) = Antenna Factor (dB/m) + Cable Factor (dB).
 3. The other emission levels were very low against the limit.
 4. Margin value = Emission level – Limit value.
 5. “ * “: Fundamental frequency.



A D T

EUT TEST CONDITION		MEASUREMENT DETAIL	
CHANNEL	Channel 11	FREQUENCY RANGE	1 ~ 25GHz
INPUT POWER (SYSTEM)	120Vac, 60Hz	DETECTOR FUNCTION	Peak (PK) Average (AV)
ENVIRONMENTAL CONDITIONS	25deg. C, 65%RH	TESTED BY	David Huang

ANTENNA POLARITY & TEST DISTANCE: HORIZONTAL AT 3 M								
NO.	FREQ. (MHz)	EMISSION LEVEL (dBuV/m)	LIMIT (dBuV/m)	MARGIN (dB)	ANTENNA HEIGHT (m)	TABLE ANGLE (Degree)	RAW VALUE (dBuV)	CORRECTION FACTOR (dB/m)
1	*2462.00	105.8 PK			1.00 H	213	74.40	31.40
2	*2462.00	95.5 AV			1.00 H	213	64.10	31.40
3	2483.50	68.5 PK	74.0	-5.5	1.00 H	213	37.10	31.40
4	2483.50	53.0 AV	54.0	-1.0	1.00 H	213	21.60	31.40
5	4924.00	41.4 PK	74.0	-32.6	1.00 H	220	4.30	37.10
6	4924.00	30.2 AV	54.0	-23.8	1.00 H	220	-6.90	37.10
ANTENNA POLARITY & TEST DISTANCE: VERTICAL AT 3 M								
NO.	FREQ. (MHz)	EMISSION LEVEL (dBuV/m)	LIMIT (dBuV/m)	MARGIN (dB)	ANTENNA HEIGHT (m)	TABLE ANGLE (Degree)	RAW VALUE (dBuV)	CORRECTION FACTOR (dB/m)
1	*2462.00	98.1 PK			1.11 V	133	66.70	31.40
2	*2462.00	88.2 AV			1.11 V	133	56.80	31.40
3	2483.50	62.0 PK	74.0	-12.0	1.00 V	182	30.60	31.40
4	2483.50	46.3 AV	54.0	-7.7	1.00 V	182	14.90	31.40
5	4924.00	43.2 PK	74.0	-30.8	1.00 V	163	6.10	37.10
6	4924.00	30.3 AV	54.0	-23.7	1.00 V	163	-6.80	37.10

- REMARKS:**
1. Emission level (dBuV/m) = Raw Value (dBuV) + Correction Factor (dB/m).
 2. Correction Factor (dB/m) = Antenna Factor (dB/m) + Cable Factor (dB).
 3. The other emission levels were very low against the limit.
 4. Margin value = Emission level – Limit value.
 5. “ * “: Fundamental frequency.



A D T

802.11n (20MHz)

EUT TEST CONDITION		MEASUREMENT DETAIL	
CHANNEL	Channel 1	FREQUENCY RANGE	1 ~ 25GHz
INPUT POWER (SYSTEM)	120Vac, 60Hz	DETECTOR FUNCTION	Peak (PK) Average (AV)
ENVIRONMENTAL CONDITIONS	25deg. C, 65%RH	TESTED BY	David Huang

ANTENNA POLARITY & TEST DISTANCE: HORIZONTAL AT 3 M								
NO.	FREQ. (MHz)	EMISSION LEVEL (dBuV/m)	LIMIT (dBuV/m)	MARGIN (dB)	ANTENNA HEIGHT (m)	TABLE ANGLE (Degree)	RAW VALUE (dBuV)	CORRECTION FACTOR (dB/m)
1	2360.00	64.7 PK	74.0	-9.3	1.32 H	36	33.70	31.00
2	2360.00	52.6 AV	54.0	-1.4	1.32 H	36	21.60	31.00
3	2390.00	58.4 PK	74.0	-15.6	1.00 H	132	27.30	31.10
4	2390.00	48.4 AV	54.0	-5.6	1.00 H	132	17.30	31.10
5	*2412.00	111.2 PK			1.03 H	210	80.00	31.20
6	*2412.00	101.2 AV			1.03 H	210	70.00	31.20
7	4824.00	45.6 PK	74.0	-28.4	1.00 H	187	8.70	36.90
8	4824.00	31.0 AV	54.0	-23.0	1.00 H	187	-5.90	36.90
ANTENNA POLARITY & TEST DISTANCE: VERTICAL AT 3 M								
NO.	FREQ. (MHz)	EMISSION LEVEL (dBuV/m)	LIMIT (dBuV/m)	MARGIN (dB)	ANTENNA HEIGHT (m)	TABLE ANGLE (Degree)	RAW VALUE (dBuV)	CORRECTION FACTOR (dB/m)
1	2360.00	64.1 PK	74.0	-9.9	1.21 V	323	33.10	31.00
2	2360.00	49.4 AV	54.0	-4.6	1.21 V	323	18.40	31.00
3	2390.00	22.4 PK	74.0	-51.6	1.00 V	198	-8.70	31.10
4	2390.00	11.5 AV	54.0	-42.5	1.00 V	198	-19.60	31.10
5	*2412.00	108.6 PK			1.00 V	180	77.40	31.20
6	*2412.00	98.7 AV			1.00 V	180	67.50	31.20
7	4824.00	45.3 PK	74.0	-28.7	1.00 V	196	8.40	36.90
8	4824.00	31.9 AV	54.0	-22.1	1.00 V	196	-5.00	36.90

- REMARKS:**
1. Emission level (dBuV/m) = Raw Value (dBuV) + Correction Factor (dB/m).
 2. Correction Factor (dB/m) = Antenna Factor (dB/m) + Cable Factor (dB).
 3. The other emission levels were very low against the limit.
 4. Margin value = Emission level – Limit value.
 5. “ * “: Fundamental frequency.



A D T

EUT TEST CONDITION		MEASUREMENT DETAIL	
CHANNEL	Channel 6	FREQUENCY RANGE	1 ~ 25GHz
INPUT POWER (SYSTEM)	120Vac, 60Hz	DETECTOR FUNCTION	Peak (PK) Average (AV)
ENVIRONMENTAL CONDITIONS	25deg. C, 65%RH	TESTED BY	David Huang

ANTENNA POLARITY & TEST DISTANCE: HORIZONTAL AT 3 M								
NO.	FREQ. (MHz)	EMISSION LEVEL (dBuV/m)	LIMIT (dBuV/m)	MARGIN (dB)	ANTENNA HEIGHT (m)	TABLE ANGLE (Degree)	RAW VALUE (dBuV)	CORRECTION FACTOR (dB/m)
1	2385.00	63.4 PK	74.0	-10.6	1.00 H	23	32.30	31.10
2	2385.00	52.6 AV	54.0	-1.4	1.00 H	23	21.50	31.10
3	*2437.00	113.8 PK			1.00 H	211	82.50	31.30
4	*2437.00	103.6 AV			1.00 H	211	72.30	31.30
5	4874.00	44.0 PK	74.0	-30.0	1.00 H	254	7.00	37.00
6	4874.00	31.8 AV	54.0	-22.2	1.00 H	254	-5.20	37.00
ANTENNA POLARITY & TEST DISTANCE: VERTICAL AT 3 M								
NO.	FREQ. (MHz)	EMISSION LEVEL (dBuV/m)	LIMIT (dBuV/m)	MARGIN (dB)	ANTENNA HEIGHT (m)	TABLE ANGLE (Degree)	RAW VALUE (dBuV)	CORRECTION FACTOR (dB/m)
1	2385.00	56.4 PK	74.0	-17.6	1.00 V	258	25.30	31.10
2	2385.00	49.0 AV	54.0	-5.0	1.00 V	258	17.90	31.10
3	*2437.00	110.2 PK			1.18 V	200	78.90	31.30
4	*2437.00	100.1 AV			1.18 V	200	68.80	31.30
5	4874.00	46.6 PK	74.0	-27.4	1.24 V	139	9.60	37.00
6	4874.00	32.9 AV	54.0	-21.1	1.24 V	139	-4.10	37.00

- REMARKS:**
1. Emission level (dBuV/m) = Raw Value (dBuV) + Correction Factor (dB/m).
 2. Correction Factor (dB/m) = Antenna Factor (dB/m) + Cable Factor (dB).
 3. The other emission levels were very low against the limit.
 4. Margin value = Emission level – Limit value.
 5. “ * “: Fundamental frequency.



A D T

EUT TEST CONDITION		MEASUREMENT DETAIL	
CHANNEL	Channel 11	FREQUENCY RANGE	1 ~ 25GHz
INPUT POWER (SYSTEM)	120Vac, 60Hz	DETECTOR FUNCTION	Peak (PK) Average (AV)
ENVIRONMENTAL CONDITIONS	25deg. C, 65%RH	TESTED BY	David Huang

ANTENNA POLARITY & TEST DISTANCE: HORIZONTAL AT 3 M								
NO.	FREQ. (MHz)	EMISSION LEVEL (dBuV/m)	LIMIT (dBuV/m)	MARGIN (dB)	ANTENNA HEIGHT (m)	TABLE ANGLE (Degree)	RAW VALUE (dBuV)	CORRECTION FACTOR (dB/m)
1	*2462.00	112.3 PK			1.00 H	212	80.90	31.40
2	*2462.00	102.0 AV			1.00 H	212	70.60	31.40
3	2483.50	72.0 PK	74.0	-2.0	1.75 H	44	40.60	31.40
4	2483.50	52.4 AV	54.0	-1.6	1.75 H	44	21.00	31.40
5	4924.00	43.3 PK	74.0	-30.7	1.00 H	191	6.20	37.10
6	4924.00	30.3 AV	54.0	-23.7	1.00 H	191	-6.80	37.10
ANTENNA POLARITY & TEST DISTANCE: VERTICAL AT 3 M								
NO.	FREQ. (MHz)	EMISSION LEVEL (dBuV/m)	LIMIT (dBuV/m)	MARGIN (dB)	ANTENNA HEIGHT (m)	TABLE ANGLE (Degree)	RAW VALUE (dBuV)	CORRECTION FACTOR (dB/m)
1	*2462.00	109.3 PK			1.13 V	187	77.90	31.40
2	*2462.00	99.3 AV			1.13 V	187	67.90	31.40
3	2483.50	69.2 PK	74.0	-4.8	1.04 V	283	37.80	31.40
4	2483.50	51.4 AV	54.0	-2.6	1.04 V	283	20.00	31.40
5	4924.00	43.1 PK	74.0	-30.9	1.00 V	209	6.00	37.10
6	4924.00	30.5 AV	54.0	-23.5	1.00 V	209	-6.60	37.10

- REMARKS:**
1. Emission level (dBuV/m) = Raw Value (dBuV) + Correction Factor (dB/m).
 2. Correction Factor (dB/m) = Antenna Factor (dB/m) + Cable Factor (dB).
 3. The other emission levels were very low against the limit.
 4. Margin value = Emission level – Limit value.
 5. “ * “: Fundamental frequency.



A D T

802.11n (40MHz)

EUT TEST CONDITION		MEASUREMENT DETAIL	
CHANNEL	Channel 1	FREQUENCY RANGE	1 ~ 25GHz
INPUT POWER (SYSTEM)	120Vac, 60Hz	DETECTOR FUNCTION	Peak (PK) Average (AV)
ENVIRONMENTAL CONDITIONS	25deg. C, 65%RH	TESTED BY	Long Chen

ANTENNA POLARITY & TEST DISTANCE: HORIZONTAL AT 3 M								
NO.	FREQ. (MHz)	EMISSION LEVEL (dBuV/m)	LIMIT (dBuV/m)	MARGIN (dB)	ANTENNA HEIGHT (m)	TABLE ANGLE (Degree)	RAW VALUE (dBuV)	CORRECTION FACTOR (dB/m)
1	2390.00	66.9 PK	74.0	-7.1	1.00 H	215	35.80	31.10
2	2390.00	52.8 AV	54.0	-1.2	1.00 H	215	21.70	31.10
3	*2422.00	108.4 PK			1.00 H	209	77.20	31.20
4	*2422.00	98.9 AV			1.00 H	209	67.70	31.20
5	4844.00	44.1 PK	74.0	-29.9	1.00 H	250	7.20	36.90
6	4844.00	30.9 AV	54.0	-23.1	1.00 H	250	-6.00	36.90
ANTENNA POLARITY & TEST DISTANCE: VERTICAL AT 3 M								
NO.	FREQ. (MHz)	EMISSION LEVEL (dBuV/m)	LIMIT (dBuV/m)	MARGIN (dB)	ANTENNA HEIGHT (m)	TABLE ANGLE (Degree)	RAW VALUE (dBuV)	CORRECTION FACTOR (dB/m)
1	2390.00	65.4 PK	74.0	-8.6	1.19 V	161	34.30	31.10
2	2390.00	52.2 AV	54.0	-1.8	1.19 V	161	21.10	31.10
3	*2422.00	105.4 PK			1.17 V	183	74.20	31.20
4	*2422.00	95.5 AV			1.17 V	183	64.30	31.20
5	4844.00	44.4 PK	74.0	-29.6	1.00 V	186	7.50	36.90
6	4844.00	30.4 AV	54.0	-23.6	1.00 V	186	-6.50	36.90

- REMARKS:**
1. Emission level (dBuV/m) = Raw Value (dBuV) + Correction Factor (dB/m).
 2. Correction Factor (dB/m) = Antenna Factor (dB/m) + Cable Factor (dB).
 3. The other emission levels were very low against the limit.
 4. Margin value = Emission level – Limit value.
 5. “ * “: Fundamental frequency.



A D T

EUT TEST CONDITION		MEASUREMENT DETAIL	
CHANNEL	Channel 4	FREQUENCY RANGE	1 ~ 25GHz
INPUT POWER (SYSTEM)	120Vac, 60Hz	DETECTOR FUNCTION	Peak (PK) Average (AV)
ENVIRONMENTAL CONDITIONS	25deg. C, 65%RH	TESTED BY	Long Chen

ANTENNA POLARITY & TEST DISTANCE: HORIZONTAL AT 3 M								
NO.	FREQ. (MHz)	EMISSION LEVEL (dBuV/m)	LIMIT (dBuV/m)	MARGIN (dB)	ANTENNA HEIGHT (m)	TABLE ANGLE (Degree)	RAW VALUE (dBuV)	CORRECTION FACTOR (dB/m)
1	2390.00	64.8 PK	74.0	-9.2	1.32 H	213	33.70	31.10
2	2390.00	52.2 AV	54.0	-1.8	1.32 H	213	21.10	31.10
3	*2437.00	105.1 PK			1.02 H	210	73.80	31.30
4	*2437.00	95.3 AV			1.02 H	210	64.00	31.30
5	4874.00	43.9 PK	74.0	-30.1	1.00 H	197	6.90	37.00
6	4874.00	30.3 AV	54.0	-23.7	1.00 H	197	-6.70	37.00
ANTENNA POLARITY & TEST DISTANCE: VERTICAL AT 3 M								
NO.	FREQ. (MHz)	EMISSION LEVEL (dBuV/m)	LIMIT (dBuV/m)	MARGIN (dB)	ANTENNA HEIGHT (m)	TABLE ANGLE (Degree)	RAW VALUE (dBuV)	CORRECTION FACTOR (dB/m)
1	2390.00	59.0 PK	74.0	-15.0	1.18 V	263	27.90	31.10
2	2390.00	47.2 AV	54.0	-6.8	1.18 V	263	16.10	31.10
3	*2437.00	99.4 PK			1.48 V	261	68.10	31.30
4	*2437.00	89.6 AV			1.48 V	261	58.30	31.30
5	4874.00	43.5 PK	74.0	-30.5	2.30 V	100	6.50	37.00
6	4874.00	30.4 AV	54.0	-23.6	2.30 V	100	-6.60	37.00

- REMARKS:**
1. Emission level (dBuV/m) = Raw Value (dBuV) + Correction Factor (dB/m).
 2. Correction Factor (dB/m) = Antenna Factor (dB/m) + Cable Factor (dB).
 3. The other emission levels were very low against the limit.
 4. Margin value = Emission level – Limit value.
 5. “ * “: Fundamental frequency.



A D T

EUT TEST CONDITION		MEASUREMENT DETAIL	
CHANNEL	Channel 7	FREQUENCY RANGE	1 ~ 25GHz
INPUT POWER (SYSTEM)	120Vac, 60Hz	DETECTOR FUNCTION	Peak (PK) Average (AV)
ENVIRONMENTAL CONDITIONS	25deg. C, 65%RH	TESTED BY	David Huang

ANTENNA POLARITY & TEST DISTANCE: HORIZONTAL AT 3 M								
NO.	FREQ. (MHz)	EMISSION LEVEL (dBuV/m)	LIMIT (dBuV/m)	MARGIN (dB)	ANTENNA HEIGHT (m)	TABLE ANGLE (Degree)	RAW VALUE (dBuV)	CORRECTION FACTOR (dB/m)
1	*2452.00	101.1 PK			1.00 H	207	69.80	31.30
2	*2452.00	91.7 AV			1.00 H	207	60.40	31.30
3	2483.50	67.4 PK	74.0	-6.6	1.00 H	213	36.00	31.40
4	2483.50	52.1 AV	54.0	-1.9	1.00 H	213	20.70	31.40
5	4904.00	44.0 PK	74.0	-30.0	1.00 H	207	7.00	37.00
6	4904.00	30.7 AV	54.0	-23.3	1.00 H	207	-6.30	37.00
ANTENNA POLARITY & TEST DISTANCE: VERTICAL AT 3 M								
NO.	FREQ. (MHz)	EMISSION LEVEL (dBuV/m)	LIMIT (dBuV/m)	MARGIN (dB)	ANTENNA HEIGHT (m)	TABLE ANGLE (Degree)	RAW VALUE (dBuV)	CORRECTION FACTOR (dB/m)
1	*2452.00	95.2 PK			1.39 V	215	63.90	31.30
2	*2452.00	85.4 AV			1.39 V	215	54.10	31.30
3	2483.50	61.1 PK	74.0	-12.9	1.13 V	230	29.70	31.40
4	2483.50	47.8 AV	54.0	-6.2	1.13 V	230	16.40	31.40
5	4904.00	25.3 PK	74.0	-48.7	1.00 V	181	-11.70	37.00
6	4904.00	15.1 AV	54.0	-38.9	1.00 V	181	-21.90	37.00

- REMARKS:**
1. Emission level (dBuV/m) = Raw Value (dBuV) + Correction Factor (dB/m).
 2. Correction Factor (dB/m) = Antenna Factor (dB/m) + Cable Factor (dB).
 3. The other emission levels were very low against the limit.
 4. Margin value = Emission level – Limit value.
 5. “ * “: Fundamental frequency.



A D T

BELOW 1GHz WORST-CASE DATA : 802.11n (20MHz)

EUT TEST CONDITION		MEASUREMENT DETAIL	
CHANNEL	Channel 6	FREQUENCY RANGE	Below 1000MHz
INPUT POWER (SYSTEM)	120Vac, 60Hz	DETECTOR FUNCTION	Quasi-Peak
ENVIRONMENTAL CONDITIONS	25deg. C, 65%RH	TESTED BY	Kay Wu

ANTENNA POLARITY & TEST DISTANCE: HORIZONTAL AT 3 M								
NO.	FREQ. (MHz)	EMISSION LEVEL (dBuV/m)	LIMIT (dBuV/m)	MARGIN (dB)	ANTENNA HEIGHT (m)	TABLE ANGLE (Degree)	RAW VALUE (dBuV)	CORRECTION FACTOR (dB/m)
1	78.51	37.2 QP	40.0	-2.8	2.00 H	343	27.60	9.60
2	140.72	27.8 QP	43.5	-15.7	2.00 H	307	13.70	14.10
3	319.60	34.5 QP	46.0	-11.5	1.00 H	208	19.10	15.40
4	480.97	27.7 QP	46.0	-18.3	2.00 H	298	8.00	19.70
5	667.63	22.5 QP	46.0	-23.5	1.00 H	229	-1.10	23.60
6	718.18	25.4 QP	46.0	-20.6	1.00 H	46	1.10	24.30

ANTENNA POLARITY & TEST DISTANCE: VERTICAL AT 3 M								
NO.	FREQ. (MHz)	EMISSION LEVEL (dBuV/m)	LIMIT (dBuV/m)	MARGIN (dB)	ANTENNA HEIGHT (m)	TABLE ANGLE (Degree)	RAW VALUE (dBuV)	CORRECTION FACTOR (dB/m)
1	78.51	33.9 QP	40.0	-6.1	3.00 V	235	24.30	9.60
2	140.72	19.5 QP	43.5	-24.0	2.00 V	34	5.40	14.10
3	325.43	24.2 QP	46.0	-21.8	1.00 V	25	8.60	15.60
4	479.03	24.9 QP	46.0	-21.1	2.00 V	346	5.30	19.60
5	549.03	19.4 QP	46.0	-26.6	2.00 V	115	-1.90	21.30
6	725.96	22.7 QP	46.0	-23.3	2.00 V	352	-1.70	24.40

- REMARKS:**
1. Emission level (dBuV/m) = Raw Value (dBuV) + Correction Factor (dB/m).
 2. Correction Factor (dB/m) = Antenna Factor (dB/m) + Cable Factor (dB).
 3. The other emission levels were very low against the limit.
 4. Margin value = Emission level – Limit value.



4.2 CONDUCTED EMISSION MEASUREMENT

4.2.1 LIMITS OF CONDUCTED EMISSION MEASUREMENT

FREQUENCY OF EMISSION (MHz)	CONDUCTED LIMIT (dBµV)	
	Quasi-peak	Average
0.15 ~ 0.5	66 to 56	56 to 46
0.5 ~ 5	56	46
5 ~ 30	60	50

- NOTE:** 1. The lower limit shall apply at the transition frequencies.
 2. The limit decreases in line with the logarithm of the frequency in the range of 0.15 to 0.50MHz.
 3. All emanations from a class A/B digital device or system, including any network of conductors and apparatus connected thereto, shall not exceed the level of field strengths specified above.

4.2.2 TEST INSTRUMENTS

DESCRIPTION & MANUFACTURER	MODEL NO.	SERIAL NO.	DATE OF CALIBRATION	DUE DATE OF CALIBRATION
Test Receiver ROHDE & SCHWARZ	ESCS30	100291	Nov. 23, 2011	Nov. 22, 2012
RF signal cable Woken	5D-FB	Cable-HYC01-01	Dec. 22, 2011	Dec. 21, 2012
LISN ROHDE & SCHWARZ	ESH3-Z5	100312	Jul. 07, 2011	Jul. 06, 2012
LISN ROHDE & SCHWARZ	ESH3-Z5	835239/001	Feb. 22, 2011	Feb. 21, 2012
Software ADT	ADT_Cond_ V7.3.7	NA	NA	NA

- NOTE:** 1. The calibration interval of the above test instruments is 12 months and the calibrations are traceable to NML/ROC and NIST/USA.
 2. The test was performed in HwaYa Shielded Room 1.
 3. The VCCI Site Registration No. is C-2040.



A D T

4.2.3 TEST PROCEDURES

- a. The EUT was placed 0.4 meters from the conducting wall of the shielded room with EUT being connected to the power mains through a line impedance stabilization network (LISN). Other support units were connected to the power mains through another LISN. The two LISNs provide 50 ohm/ 50uH of coupling impedance for the measuring instrument.
- b. Both lines of the power mains connected to the EUT were checked for maximum conducted interference.
- c. The frequency range from 150kHz to 30MHz was searched. Emission levels under (Limit - 20dB) was not recorded.

NOTE: All modes of operation were investigated and the worst-case emissions are reported.

4.2.4 DEVIATION FROM TEST STANDARD

No deviation.

4.2.5 TEST SETUP

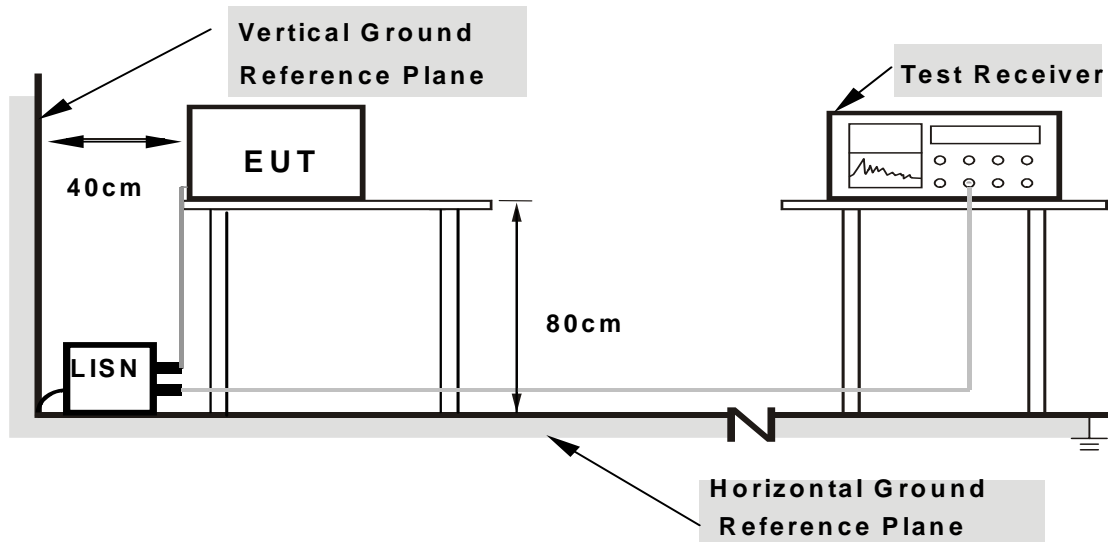

Note: 1.Support units were connected to second LISN.

2.Both of LISNs (AMN) are 80 cm from EUT and at least 80 from other units and other metal planes

For the actual test configuration, please refer to the attached file (Test Setup Photo).

4.2.6 EUT OPERATING CONDITIONS

Same as 4.1.6.

4.2.7 TEST RESULTS

CONDUCTED WORST-CASE DATA : 802.11n(20MHz)

PHASE	Line 1	6dB BANDWIDTH	9kHz
-------	--------	---------------	------

No	Freq. [MHz]	Corr. Factor (dB)	Reading Value [dB (uV)]		Emission Level [dB (uV)]		Limit [dB (uV)]		Margin (dB)	
			Q.P.	AV.	Q.P.	AV.	Q.P.	AV.	Q.P.	AV.
1	0.170	0.12	48.56	36.28	48.68	36.40	64.98	54.98	-16.31	-18.59
2	0.228	0.12	47.44	34.49	47.56	34.61	62.52	52.52	-14.96	-17.91
3	0.271	0.12	48.17	43.07	48.29	43.19	61.08	51.08	-12.79	-7.89
4	0.463	0.12	38.88	25.15	39.00	25.27	56.65	46.65	-17.64	-21.37
5	0.939	0.16	33.61	19.40	33.77	19.56	56.00	46.00	-22.23	-26.44
6	23.375	1.29	19.34	12.85	20.63	14.14	60.00	50.00	-39.37	-35.86

- REMARKS:**
1. Q.P. and AV. are abbreviations of quasi-peak and average individually.
 2. "-": The Quasi-peak reading value also meets average limit and measurement with the average detector is unnecessary.
 3. The emission levels of other frequencies were very low against the limit.
 4. Margin value = Emission level - Limit value
 5. Correction factor = Insertion loss + Cable loss
 6. Emission Level = Correction Factor + Reading Value.

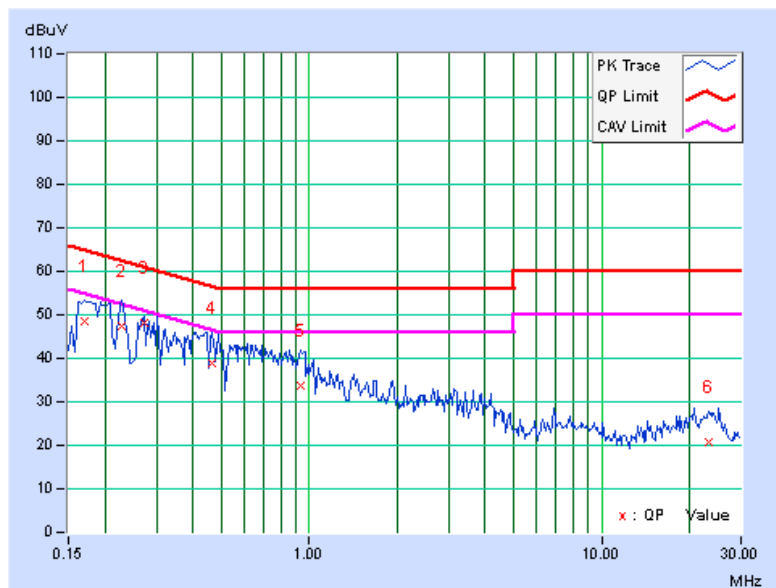

PHASE	Line 2	6dB BANDWIDTH	9kHz
-------	--------	---------------	------

No	Freq. [MHz]	Corr.	Reading Value		Emission Level		Limit		Margin	
		Factor (dB)	Q.P. [dB (uV)]	AV. [dB (uV)]	Q.P. [dB (uV)]	AV. [dB (uV)]	Q.P. [dB (uV)]	AV. [dB (uV)]	Q.P. (dB)	AV. (dB)
1	0.150	0.12	49.34	32.01	49.46	32.13	66.00	56.00	-16.54	-23.87
2	0.271	0.13	48.09	43.15	48.22	43.28	61.08	51.08	-12.86	-7.80
3	0.466	0.14	39.64	26.17	39.78	26.31	56.58	46.58	-16.79	-20.26
4	0.619	0.15	39.11	24.20	39.26	24.35	56.00	46.00	-16.74	-21.65
5	0.920	0.17	35.43	21.23	35.60	21.40	56.00	46.00	-20.40	-24.60
6	7.363	0.48	18.48	11.00	18.96	11.48	60.00	50.00	-41.04	-38.52

- REMARKS:**
1. Q.P. and AV. are abbreviations of quasi-peak and average individually.
 2. "-": The Quasi-peak reading value also meets average limit and measurement with the average detector is unnecessary.
 3. The emission levels of other frequencies were very low against the limit.
 4. Margin value = Emission level - Limit value
 5. Correction factor = Insertion loss + Cable loss
 6. Emission Level = Correction Factor + Reading Value.

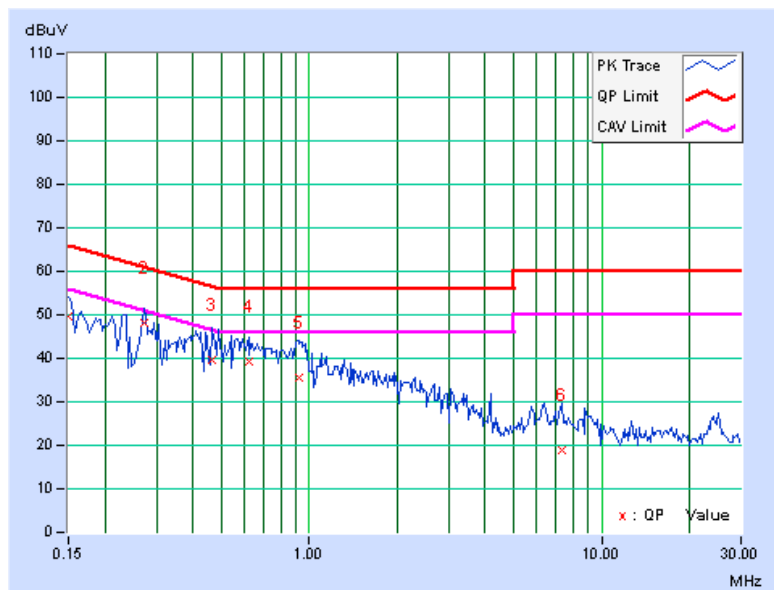

4.3 6dB BANDWIDTH MEASUREMENT

4.3.1 LIMITS OF 6dB BANDWIDTH MEASUREMENT

The minimum of 6dB Bandwidth Measurement is 0.5 MHz.

4.3.2 TEST SETUP

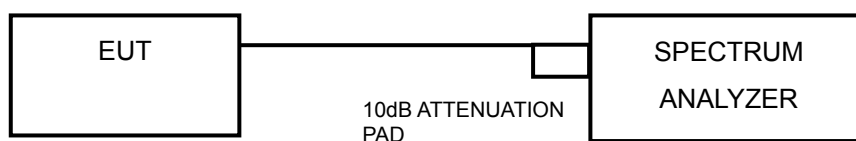

4.3.3 TEST INSTRUMENTS

Refer to section 4.1.2 to get information of above instrument.

4.3.4 TEST PROCEDURE

1. Set resolution bandwidth (RBW) = approximately 1% of the emission bandwidth
2. Set the video bandwidth (VBW) $\geq 3 \times$ RBW, Detector = Peak.
3. Trace mode = max hold.
4. Sweep = auto couple.
5. Measure the maximum width of the emission that is constrained by the frequencies associated with the two amplitude points (upper and lower) that are attenuated by 6 dB relative to the maximum level measured in the fundamental emission

4.3.5 DEVIATION FROM TEST STANDARD

No deviation.

4.3.6 EUT OPERATING CONDITIONS

The software provided by client to enable the EUT under transmission condition continuously at lowest, middle and highest channel frequencies individually.



4.3.7 TEST RESULTS

802.11b

CHANNEL	CHANNEL FREQUENCY (MHz)	6dB BANDWIDTH (MHz)	MINIMUM LIMIT (MHz)	PASS / FAIL
1	2412	12.26	0.5	PASS
6	2437	12.25	0.5	PASS
11	2462	12.26	0.5	PASS

802.11g

CHANNEL	CHANNEL FREQUENCY (MHz)	6dB BANDWIDTH (MHz)	MINIMUM LIMIT (MHz)	PASS / FAIL
1	2412	16.59	0.5	PASS
6	2437	16.56	0.5	PASS
11	2462	16.62	0.5	PASS

802.11n (20MHz)

CHANNEL	CHANNEL FREQUENCY (MHz)	6dB BANDWIDTH (MHz)			MINIMUM LIMIT (MHz)	PASS / FAIL
		CHAIN 0	CHAIN 1	CHAIN 2		
1	2412	17.64	17.64	17.69	0.5	PASS
6	2437	17.68	17.66	17.64	0.5	PASS
11	2462	17.65	17.64	17.68	0.5	PASS

802.11n (40MHz)

CHANNEL	CHANNEL FREQUENCY (MHz)	6dB BANDWIDTH (MHz)			MINIMUM LIMIT (MHz)	PASS / FAIL
		CHAIN 0	CHAIN 1	CHAIN 2		
1	2422	36.26	36.23	36.23	0.5	PASS
4	2437	36.16	36.22	36.28	0.5	PASS
7	2452	36.19	36.15	36.32	0.5	PASS

4.4 CONDUCTED OUTPUT POWER

4.4.1 LIMITS OF CONDUCTED OUTPUT POWER MEASUREMENT

For systems using digital modulation in the 2400–2483.5 MHz bands: 1 Watt (30dBm)

4.4.2 TEST SETUP

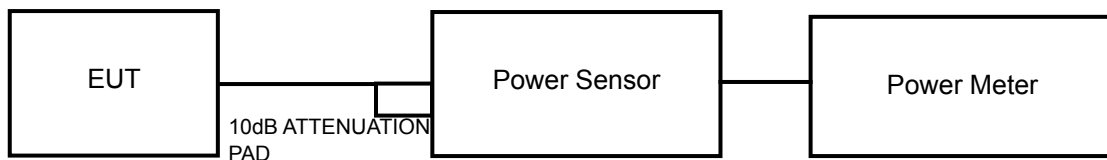

4.4.3 TEST INSTRUMENTS

Refer to section 4.1.2 to get information of above instrument.

4.4.4 TEST PROCEDURES

A power sensor was used on the output port of the EUT. A power meter was used to read the response of the power sensor. Record the power level.

4.4.5 DEVIATION FROM TEST STANDARD

No deviation.

4.4.6 EUT OPERATING CONDITIONS

Same as Item 4.3.6.



4.4.7 TEST RESULTS

802.11b

CHANNEL	CHANNEL FREQUENCY (MHz)	POWER OUTPUT (mW)	POWER OUTPUT (dBm)	POWER LIMIT (dBm)	PASS/FAIL
1	2412	141.3	21.5	30	PASS
6	2437	154.9	21.9	30	PASS
11	2462	123.0	20.9	30	PASS

802.11g

CHANNEL	CHANNEL FREQUENCY (MHz)	POWER OUTPUT (mW)	POWER OUTPUT (dBm)	POWER LIMIT (dBm)	PASS/FAIL
1	2412	234.4	23.7	30	PASS
6	2437	245.5	23.9	30	PASS
11	2462	208.9	23.2	30	PASS

802.11n (20MHz)

CHAN.	CHAN. FREQ. (MHz)	POWER OUTPUT (dBm)			TOTAL POWER (mW)	TOTAL POWER (dBm)	POWER LIMIT (dBm)	PASS / FAIL
		CHAIN 0	CHAIN 1	CHAIN 2				
1	2412	23.3	23.2	23.3	636.5	28.0	29.2	PASS
6	2437	23.9	24.2	24.1	765.5	28.8	29.2	PASS
11	2462	23.1	23.1	23.3	622.1	27.9	29.2	PASS

Directional gain = 2.0dBi + 10log(3)=6.8dBi > 6dBi, so the conducted power limit shall be reduced to 30-(6.8-6)=29.2dBm

802.11n (40MHz)

CHAN.	CHAN. FREQ. (MHz)	POWER OUTPUT (dBm)			TOTAL POWER (mW)	TOTAL POWER (dBm)	POWER LIMIT (dBm)	PASS / FAIL
		CHAIN 0	CHAIN 1	CHAIN 2				
1	2422	22.9	23.1	22.9	594.1	27.7	29.2	PASS
4	2437	23.3	23.2	23.3	636.5	28.0	29.2	PASS
7	2452	22.3	22.4	22.6	525.6	27.2	29.2	PASS

Directional gain = 2.0dBi + 10log(3)=6.8dBi > 6dBi, so the conducted power limit shall be reduced to 30-(6.8-6)=29.2dBm

4.5 POWER SPECTRAL DENSITY MEASUREMENT

4.5.1 LIMITS OF POWER SPECTRAL DENSITY MEASUREMENT

The Maximum of Power Spectral Density Measurement is 8dBm.

4.5.2 TEST SETUP

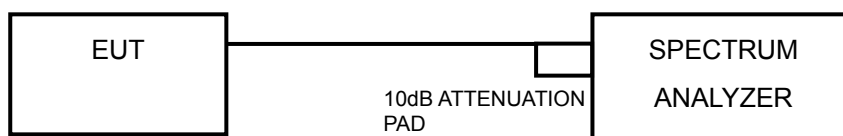

4.5.3 TEST INSTRUMENTS

Refer to section 4.1.2 to get information of above instrument.

4.5.4 TEST PROCEDURE

1. Set the RBW = 100 kHz, VBW = 300 kHz, Detector = peak.
2. Sweep time = auto couple, Trace mode = max hold, allow trace to fully stabilize.
3. Use the peak marker function to determine the maximum power level in any 100 kHz band segment within the fundamental EBW.
4. Scale the observed power level to an equivalent value in 3 kHz by adjusting (reducing) the measured power by a bandwidth correction factor (BWCF) where $BWCF = 10\log(3 \text{ kHz}/100\text{kHz})$

4.5.5 DEVIATION FROM TEST STANDARD

No deviation.

4.5.6 EUT OPERATING CONDITION

Same as Item 4.3.6



4.5.7 TEST RESULTS

802.11b

Channel	FREQ. (MHz)	PSD (dBm/100kHz)	PSD (dBm/3kHz)	Limit (dBm/3kHz)	PASS /FAIL
1	2412	7.58	-7.65	8	PASS
6	2437	8.02	-7.21	8	PASS
11	2462	6.98	-8.25	8	PASS

802.11g

Channel	FREQ. (MHz)	PSD (dBm/100kHz)	PSD (dBm/3kHz)	Limit (dBm/3kHz)	PASS /FAIL
1	2412	4.07	-11.16	8	PASS
6	2437	4.21	-11.02	8	PASS
11	2462	3.45	-11.78	8	PASS

802.11n (20MHz)

Tx chain	Channel	FREQ. (MHz)	PSD (dBm/100kHz)	PSD (dBm/3kHz)	10 log (N=3) dB	Total PSD (dBm/3kHz)	Limit (dBm/3kHz)	PASS /FAIL
0	1	2412	2.87	-12.36	4.77	-7.59	7.2	PASS
	6	2437	3.56	-11.67	4.77	-6.90	7.2	PASS
	11	2462	2.82	-12.41	4.77	-7.64	7.2	PASS
1	1	2412	2.48	-12.75	4.77	-7.98	7.2	PASS
	6	2437	3.47	-11.76	4.77	-6.99	7.2	PASS
	11	2462	2.41	-12.82	4.77	-8.05	7.2	PASS
2	1	2412	1.80	-13.43	4.77	-8.66	7.2	PASS
	6	2437	2.70	-12.53	4.77	-7.76	7.2	PASS
	11	2462	1.97	-13.26	4.77	-8.49	7.2	PASS

Directional gain = 2.0dBi + 10log(3)=6.8dBi > 6dBi, so the power density limit shall be reduced to 8-(6.8-6)=7.2dBm



802.11n (40MHz)

TX chain	Channel	FREQ. (MHz)	PSD (dBm/100kHz)	PSD (dBm/3kHz)	10 log (N=3) dB	Total PSD (dBm/3kHz)	Limit (dBm/3kHz)	PASS /FAIL
0	1	2422	-0.13	-15.36	4.77	-10.59	7.2	PASS
	4	2437	0.19	-15.04	4.77	-10.27	7.2	PASS
	7	2452	-0.78	-16.01	4.77	-11.24	7.2	PASS
1	1	2422	-0.31	-15.54	4.77	-10.77	7.2	PASS
	4	2437	-0.32	-15.55	4.77	-10.78	7.2	PASS
	7	2452	-1.14	-16.37	4.77	-11.60	7.2	PASS
2	1	2422	-0.85	-16.08	4.77	-11.31	7.2	PASS
	4	2437	-0.47	-15.7	4.77	-10.93	7.2	PASS
	7	2452	-1.09	-16.32	4.77	-11.55	7.2	PASS

Directional gain = $2.0\text{dBi} + 10\log(3) = 6.8\text{dBi} > 6\text{dBi}$, so the power density limit shall be reduced to $8 - (6.8 - 6) = 7.2\text{dBm}$

4.6 CONDUCTED EMISSION MEASUREMENT

4.6.1 LIMITS OF BAND EDGES MEASUREMENT

Below -20dB of the highest emission level of operating band (in 100kHz Resolution Bandwidth).

4.6.2 TEST SETUP

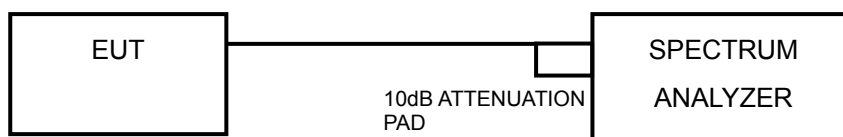

4.6.3 TEST INSTRUMENTS

Refer to section 4.1.2 to get information of above instrument.

4.6.4 TEST PROCEDURE

MEASUREMENT PROCEDURE REF

1. Set the RBW = 100 kHz.
2. Set the VBW \geq 300 kHz.
3. Detector = peak.
4. Sweep time = auto couple.
5. Trace mode = max hold.
6. Allow trace to fully stabilize.
7. Use the peak marker function to determine the maximum power level in any 100 kHz band segment within the fundamental EBW.



A D T

MEASUREMENT PROCEDURE OOBE

1. Set RBW = 100 kHz.
2. Set VBW \geq 300 kHz.
3. Set span to encompass the spectrum to be examined.
4. Detector = peak.
5. Trace Mode = max hold.
6. Sweep = auto couple.

4.6.5 DEVIATION FROM TEST STANDARD

No deviation.

4.6.6 EUT OPERATING CONDITION

Same as Item 4.3.6

4.6.7 TEST RESULTS

The conducted emission test is performed on each TX port of operating mode without summing or adding $10\log(N)$ since the limit is relative emission limit. Only worst data of each operating mode is presented.

The spectrum plots are attached on the following pages. D1 line indicates the highest level, and D2 line indicates the 20dB offset below D1. It shows compliance with the requirement in part 15.247(d).

4.6.8 TEST RESULTS

802.11b

CH 1

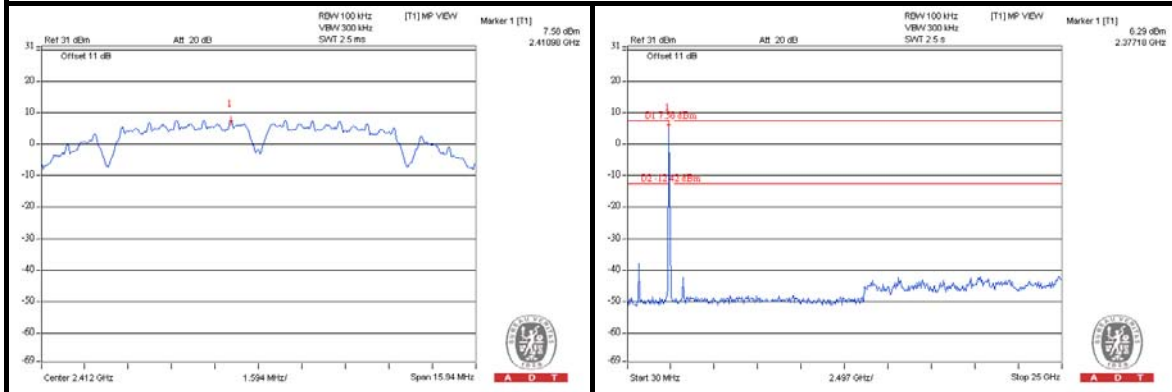

CH 6

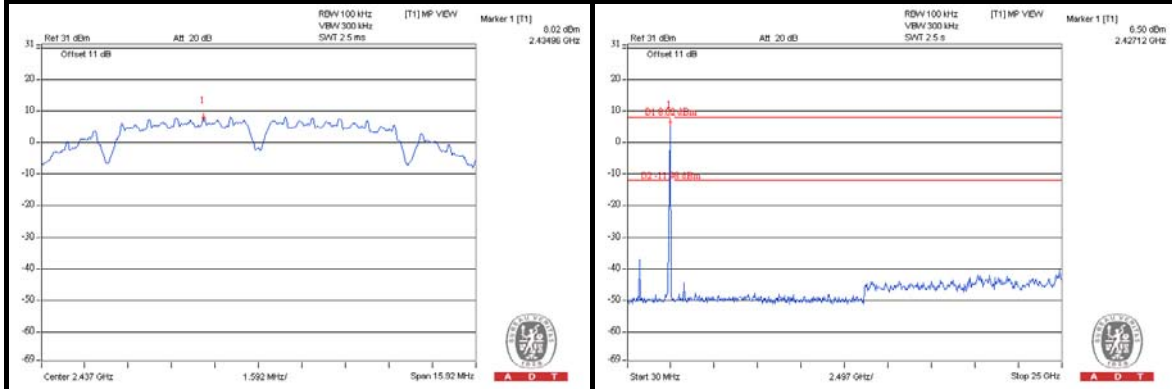

CH 11

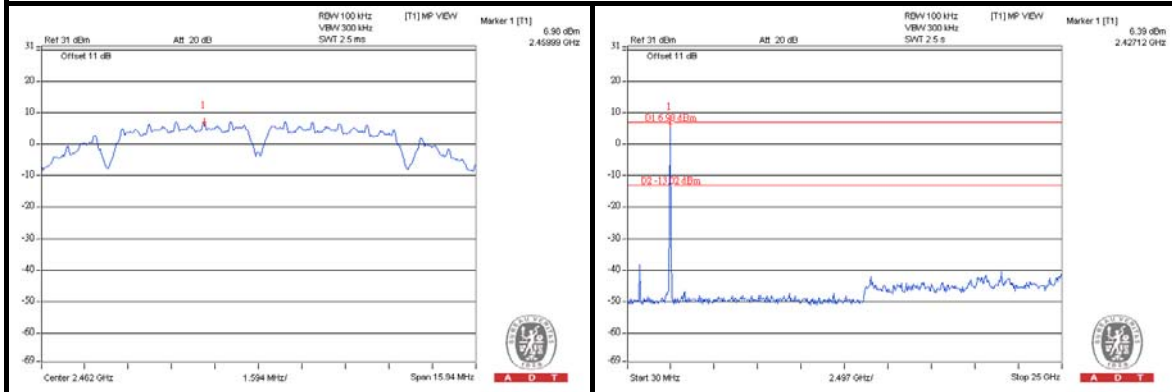

802.11g

CH 1

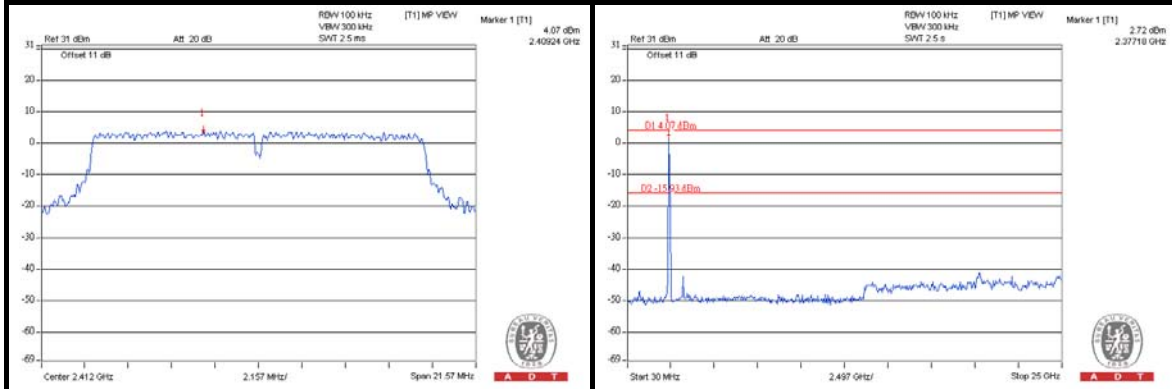

CH 6

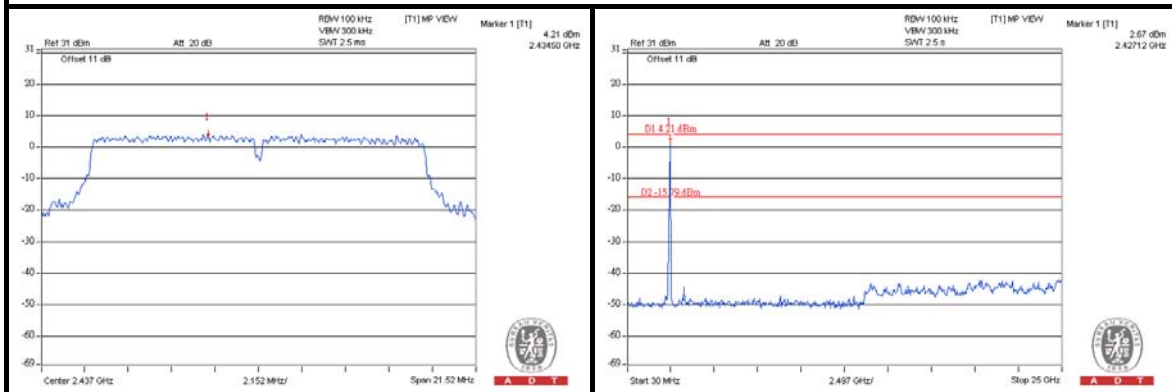

CH 11

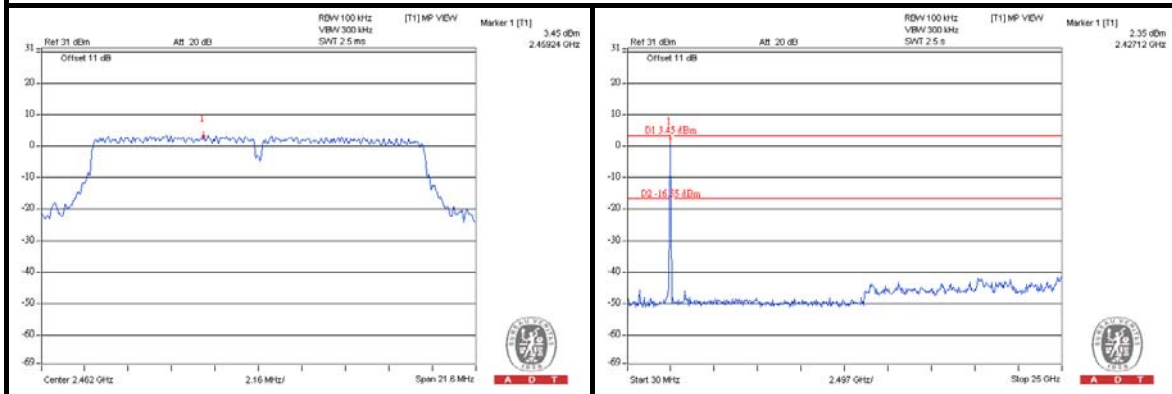

802.11n (20MHz)

CH 1

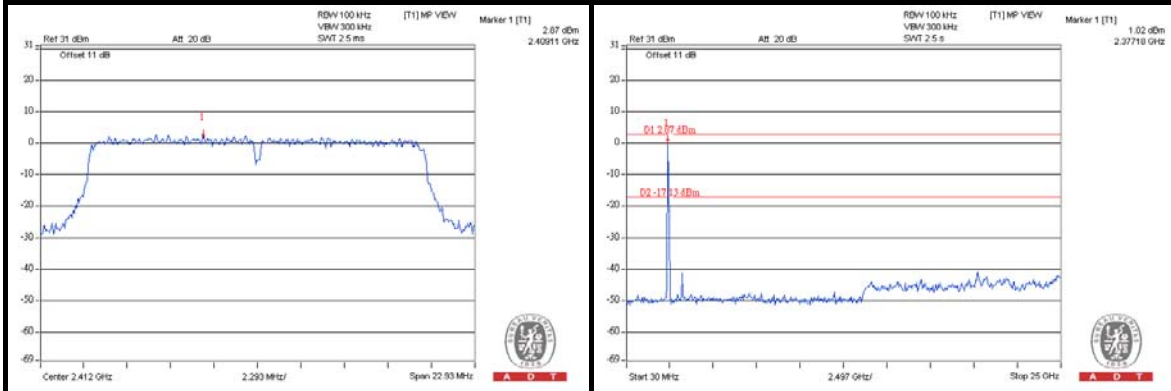

CH 6

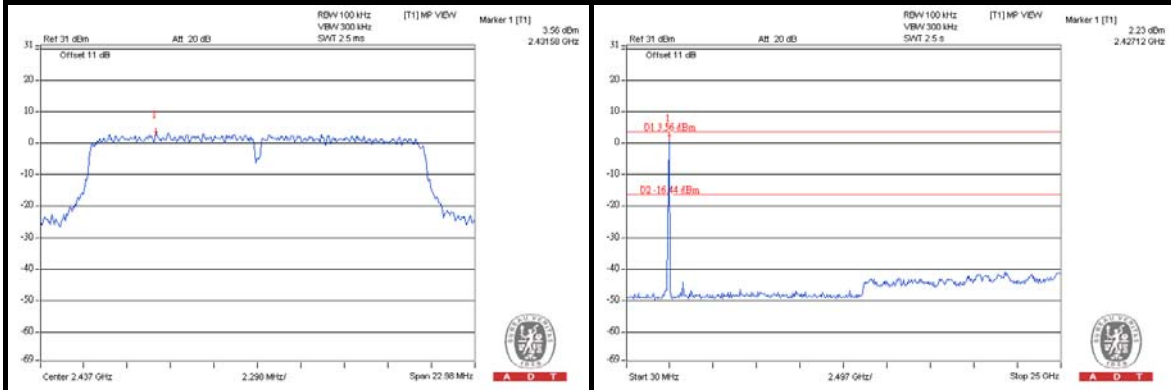

CH 11

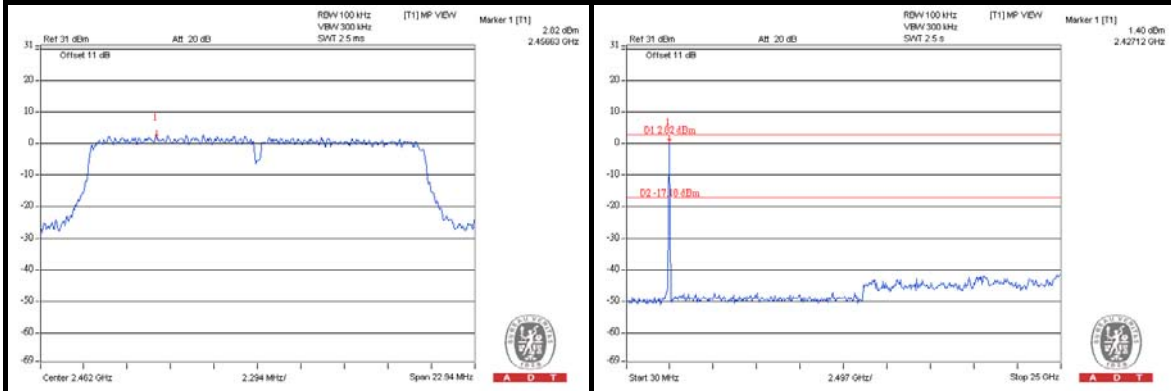

802.11n (40MHz)

CH 1

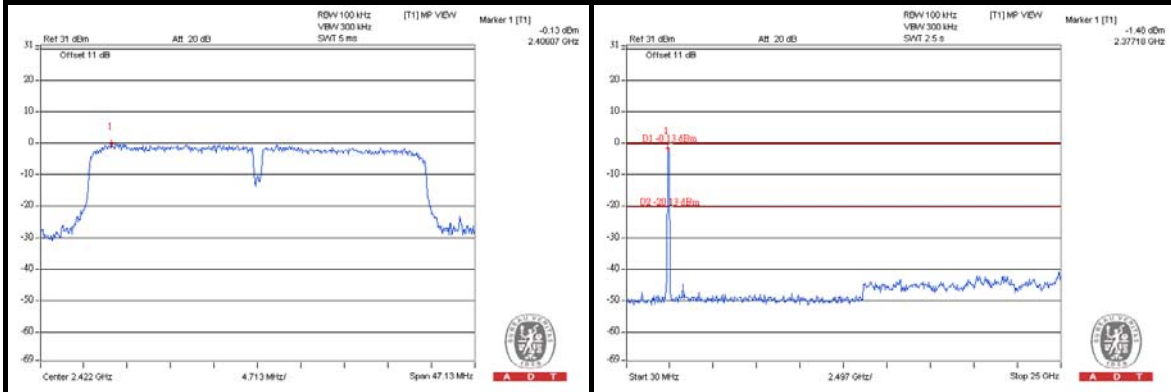

CH 4

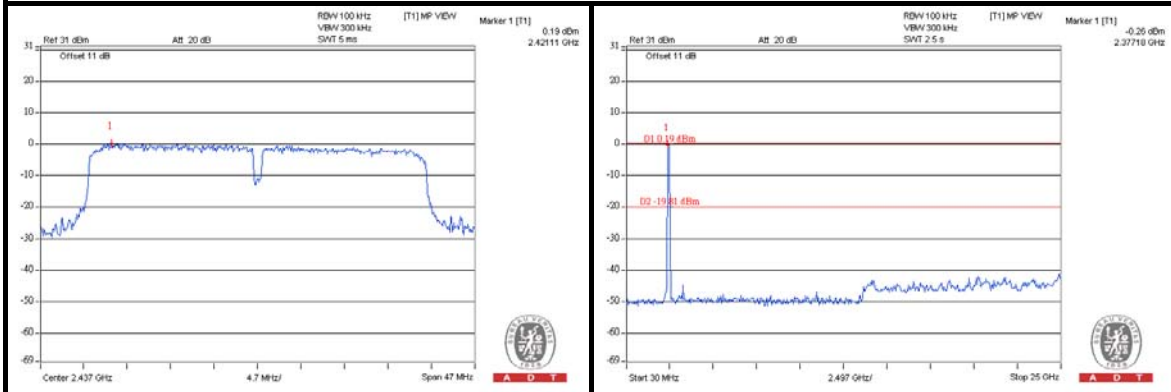

CH 7

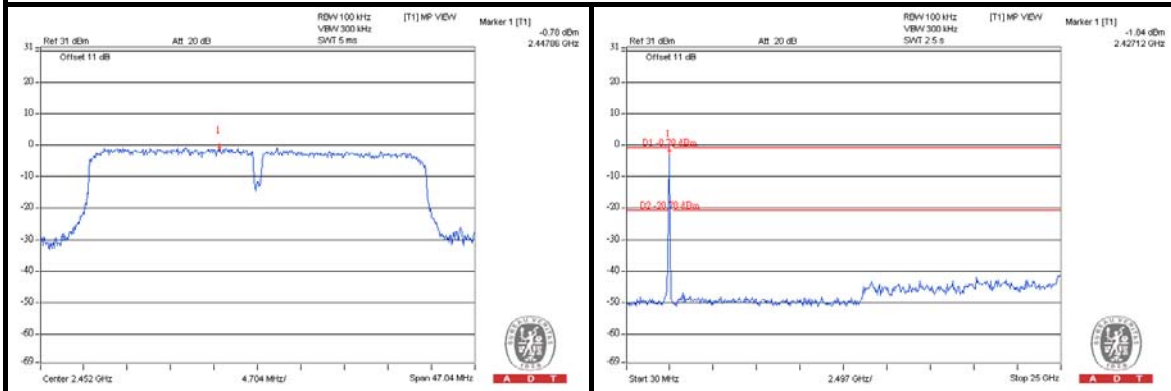



5. TEST TYPES AND RESULTS (FOR 5.0GHz BAND)

5.1 RADIATED EMISSION MEASUREMENT

5.1.1 LIMITS OF RADIATED EMISSION MEASUREMENT

Radiated emissions which fall in the restricted bands, as defined in Section 15.205(a), must also comply with the radiated emission limits specified in Section 15.209(a). Other emissions shall be at least 20dB below the highest level of the desired power.

FREQUENCIES (MHz)	FIELD STRENGTH (microvolts/meter)	MEASUREMENT DISTANCE (meters)
0.009 ~ 0.490	2400/F(kHz)	300
0.490 ~ 1.705	24000/F(kHz)	30
1.705 ~ 30.0	30	30
30 ~ 88	100	3
88 ~ 216	150	3
216 ~ 960	200	3
Above 960	500	3

NOTE:

1. The lower limit shall apply at the transition frequencies.
2. Emission level (dBuV/m) = 20 log Emission level (uV/m).
3. As shown in 15.35(b), for frequencies above 1000MHz, the field strength limits are based on average detector, however, the peak field strength of any emission shall not exceed the maximum permitted average limits, specified above by more than 20dB under any condition of modulation.



A D T

5.1.2 TEST INSTRUMENTS

DESCRIPTION & MANUFACTURER	MODEL NO.	SERIAL NO.	DATE OF CALIBRATION	DUE DATE OF CALIBRATION
Test Receiver ROHDE & SCHWARZ	ESIB7	100212	Aug. 02, 2011	Aug. 01, 2012
Spectrum Analyzer ROHDE & SCHWARZ	FSP40	100041	Jul. 21, 2011	Jul. 20, 2012
BILOG Antenna SCHWARZBECK	VULB9168	9168-160	Apr. 13, 2011	Apr. 12, 2012
HORN Antenna SCHWARZBECK	9120D	209	Aug. 25, 2011	Aug. 24, 2012
HORN Antenna SCHWARZBECK	BBHA 9170	148	Jul. 20, 2011	Jul. 19, 2012
Preamplifier Agilent	8447D	2944A10633	Oct. 29, 2011	Oct. 28, 2012
Preamplifier Agilent	8449B	3008A01964	Oct. 29, 2011	Oct. 28, 2012
RF signal cable HUBER+SUHNNER	SUCOFLEX 104	250723/4	Aug. 30, 2011	Aug. 29, 2012
RF signal cable HUBER+SUHNNER	SUCOFLEX 106	12738/6+309224/ 4	Aug. 30, 2011	Aug. 29, 2012
Software ADT.	ADT_Radiated_ V7.6.15.9.2	NA	NA	NA
Antenna Tower inn-co GmbH	MA 4000	013303	NA	NA
Antenna Tower Controller inn-co GmbH	CO2000	017303	NA	NA
Turn Table ADT.	TT100.	TT93021703	NA	NA
Turn Table Controller ADT.	SC100.	SC93021703	NA	NA
26GHz ~ 40GHz Amplifier	EM26400	815221	Oct. 29, 2011	Oct. 28, 2012
High Speed Peak Power Meter	ML2495A	0842014	Apr. 26, 2011	Apr. 25, 2012
Power Sensor	MA2411B	0738404	Apr. 26, 2011	Apr. 25, 2012

- NOTE:**
1. The calibration interval of the above test instruments is 12 months and the calibrations are traceable to NML/ROC and NIST/USA.
 2. The test was performed in HwaYa Chamber 3.
 3. The horn antenna and HP preamplifier (model: 8449B) are used only for the measurement of emission frequency above 1GHz if tested.
 4. The FCC Site Registration No. is 988962.
 5. The IC Site Registration No. is IC 7450F-3.



A D T

5.1.3 TEST PROCEDURES

- a. The EUT was placed on the top of a rotating table 0.8 meters above the ground at a 3 meters semi-anechoic chamber. The table was rotated 360 degrees to determine the position of the highest radiation.
- b. The EUT was set 3 meters away from the interference-receiving antenna, which was mounted on the top of a variable-height antenna tower.
- c. The antenna is a broadband antenna, and its height is varied from one meter to four meters above the ground to determine the maximum value of the field strength. Both horizontal and vertical polarizations of the antenna are set to make the measurement.
- d. For each suspected emission, the EUT was arranged to its worst case and then the antenna was tuned to heights from 1 meter to 4 meters and the rotatable table was turned from 0 degrees to 360 degrees to find the maximum reading.
- e. The test-receiver system was set to Peak Detect Function and Specified Bandwidth with Maximum Hold Mode.
- f. If the emission level of the EUT in peak mode was lower than the limit specified, then testing could be stopped and the peak values of the EUT would be reported. Otherwise the emissions would be re-tested one by one using peak, quasi-peak or average method as specified and then reported in a data sheet.

NOTE:

1. The resolution bandwidth and video bandwidth of test receiver/spectrum analyzer is 120kHz for Quasi-peak detection at frequency below 1GHz.
2. The resolution bandwidth of test receiver/spectrum analyzer is 100kHz and video bandwidth is 300kHz for Peak detection at frequency above 1GHz.
3. The resolution bandwidth of test receiver/spectrum analyzer is 1MHz and the video bandwidth is 1kHz for Average detection (AV) at frequency above 1GHz.
4. All modes of operation were investigated and the worst-case emissions are reported.

5.1.4 DEVIATION FROM TEST STANDARD

No deviation.

5.1.5 TEST SETUP

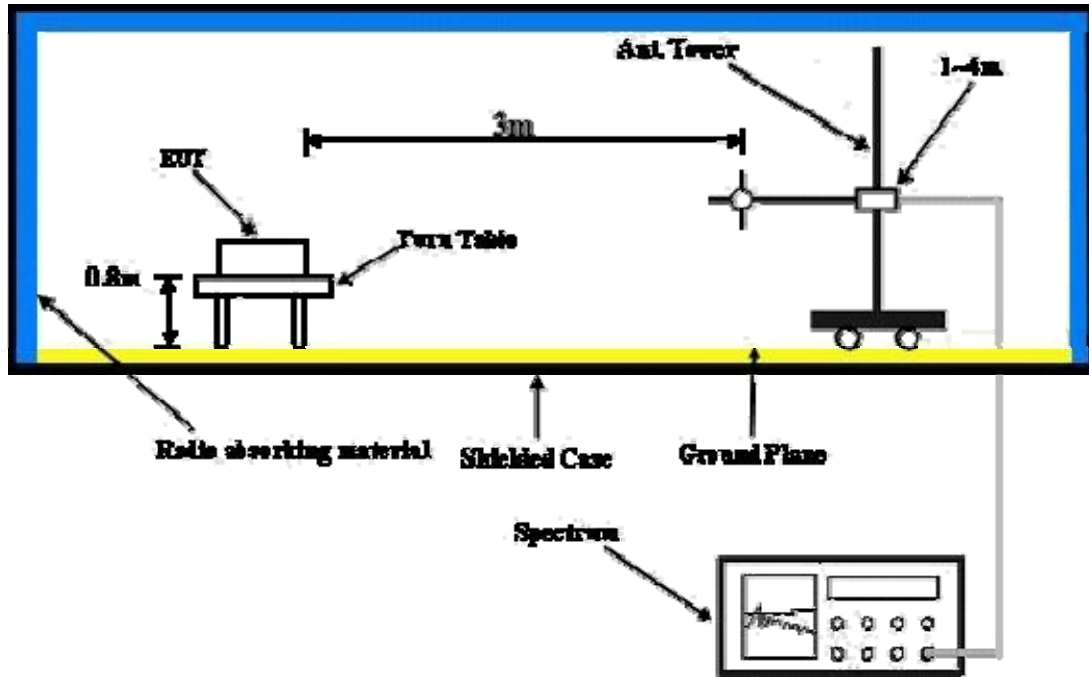

For the actual test configuration, please refer to the attached file (Test Setup Photo).

5.1.6 EUT OPERATING CONDITIONS

Same as 4.1.6.



A D T

5.1.7 TEST RESULTS

802.11a

EUT TEST CONDITION		MEASUREMENT DETAIL	
CHANNEL	Channel 149	FREQUENCY RANGE	1 ~ 40GHz
INPUT POWER (SYSTEM)	120Vac, 60Hz	DETECTOR FUNCTION	Peak (PK) Average (AV)
ENVIRONMENTAL CONDITIONS	25deg. C, 65%RH	TESTED BY	Kay Wu

ANTENNA POLARITY & TEST DISTANCE: HORIZONTAL AT 3 M								
NO.	FREQ. (MHz)	EMISSION LEVEL (dBuV/m)	LIMIT (dBuV/m)	MARGIN (dB)	ANTENNA HEIGHT (m)	TABLE ANGLE (Degree)	RAW VALUE (dBuV)	CORRECTION FACTOR (dB/m)
1	#5725.00	77.6 PK	85.1	-7.5	1.31 H	69	39.20	38.40
2	#5725.00	61.8 AV	74.9	-13.1	1.31 H	69	23.40	38.40
3	*5745.00	105.1 PK			1.31 H	69	66.70	38.40
4	*5745.00	94.9 AV			1.31 H	69	56.50	38.40
5	11490.00	57.9 PK	74.0	-16.1	1.00 H	268	8.90	49.00
6	11490.00	44.6 AV	54.0	-9.4	1.00 H	268	-4.40	49.00
ANTENNA POLARITY & TEST DISTANCE: VERTICAL AT 3 M								
NO.	FREQ. (MHz)	EMISSION LEVEL (dBuV/m)	LIMIT (dBuV/m)	MARGIN (dB)	ANTENNA HEIGHT (m)	TABLE ANGLE (Degree)	RAW VALUE (dBuV)	CORRECTION FACTOR (dB/m)
1	#5725.00	77.5 PK	84.4	-6.9	1.00 V	74	39.10	38.40
2	#5725.00	61.9 AV	74.1	-12.2	1.00 V	74	23.50	38.40
3	*5745.00	104.4 PK			1.00 V	74	66.00	38.40
4	*5745.00	94.1 AV			1.00 V	74	55.70	38.40
5	11490.00	61.5 PK	74.0	-12.5	1.20 V	238	12.50	49.00
6	11490.00	48.4 AV	54.0	-5.6	1.20 V	238	-0.60	49.00

- REMARKS:**
1. Emission level (dBuV/m) = Raw Value (dBuV) + Correction Factor (dB/m).
 2. Correction Factor (dB/m) = Antenna Factor (dB/m) + Cable Factor (dB).
 3. The other emission levels were very low against the limit.
 4. Margin value = Emission level – Limit value.
 5. “ * “: Fundamental frequency.
 6. The limit value is defined as per 15.247.
 7. "#":The radiated frequency is out the restricted band.



A D T

EUT TEST CONDITION		MEASUREMENT DETAIL	
CHANNEL	Channel 157	FREQUENCY RANGE	1 ~ 40GHz
INPUT POWER (SYSTEM)	120Vac, 60Hz	DETECTOR FUNCTION	Peak (PK) Average (AV)
ENVIRONMENTAL CONDITIONS	25deg. C, 65%RH	TESTED BY	Kay Wu

ANTENNA POLARITY & TEST DISTANCE: HORIZONTAL AT 3 M								
NO.	FREQ. (MHz)	EMISSION LEVEL (dBuV/m)	LIMIT (dBuV/m)	MARGIN (dB)	ANTENNA HEIGHT (m)	TABLE ANGLE (Degree)	RAW VALUE (dBuV)	CORRECTION FACTOR (dB/m)
1	*5785.00	103.0 PK			1.41 H	73	64.50	38.50
2	*5785.00	93.1 AV			1.41 H	73	54.60	38.50
3	11570.00	58.8 PK	74.0	-15.2	1.31 H	258	10.00	48.80
4	11570.00	45.2 AV	54.0	-8.8	1.31 H	258	-3.60	48.80
5	#17355.00	61.8 PK	83.0	-21.2	1.00 H	314	9.20	52.60
6	#17355.00	46.8 AV	73.1	-26.3	1.00 H	314	-5.80	52.60
ANTENNA POLARITY & TEST DISTANCE: VERTICAL AT 3 M								
NO.	FREQ. (MHz)	EMISSION LEVEL (dBuV/m)	LIMIT (dBuV/m)	MARGIN (dB)	ANTENNA HEIGHT (m)	TABLE ANGLE (Degree)	RAW VALUE (dBuV)	CORRECTION FACTOR (dB/m)
1	*5785.00	101.8 PK			1.00 V	75	63.30	38.50
2	*5785.00	91.8 AV			1.00 V	75	53.30	38.50
3	11570.00	60.9 PK	74.0	-13.1	1.30 V	240	12.10	48.80
4	11570.00	47.9 AV	54.0	-6.1	1.30 V	240	-0.90	48.80
5	#17355.00	62.7 PK	81.8	-19.1	1.00 V	332	10.10	52.60
6	#17355.00	48.8 AV	71.8	-23.0	1.00 V	332	-3.80	52.60

- REMARKS:**
1. Emission level (dBuV/m) = Raw Value (dBuV) + Correction Factor (dB/m).
 2. Correction Factor (dB/m) = Antenna Factor (dB/m) + Cable Factor (dB).
 3. The other emission levels were very low against the limit.
 4. Margin value = Emission level – Limit value.
 5. “ * “: Fundamental frequency.
 6. The limit value is defined as per 15.247.
 7. “#“: The radiated frequency is out the restricted band.



A D T

EUT TEST CONDITION		MEASUREMENT DETAIL	
CHANNEL	Channel 165	FREQUENCY RANGE	1 ~ 40GHz
INPUT POWER (SYSTEM)	120Vac, 60Hz	DETECTOR FUNCTION	Peak (PK) Average (AV)
ENVIRONMENTAL CONDITIONS	25deg. C, 65%RH	TESTED BY	Kay Wu

ANTENNA POLARITY & TEST DISTANCE: HORIZONTAL AT 3 M								
NO.	FREQ. (MHz)	EMISSION LEVEL (dBuV/m)	LIMIT (dBuV/m)	MARGIN (dB)	ANTENNA HEIGHT (m)	TABLE ANGLE (Degree)	RAW VALUE (dBuV)	CORRECTION FACTOR (dB/m)
1	*5825.00	102.9 PK			1.02 H	176	64.30	38.60
2	*5825.00	92.8 AV			1.02 H	176	54.20	38.60
3	#5850.00	62.0 PK	82.9	-20.9	1.02 H	176	23.40	38.60
4	#5850.00	45.2 AV	72.8	-27.6	1.02 H	176	6.60	38.60
5	11650.00	58.0 PK	74.0	-16.0	1.30 H	268	9.30	48.70
6	11650.00	44.4 AV	54.0	-9.6	1.30 H	268	-4.30	48.70
ANTENNA POLARITY & TEST DISTANCE: VERTICAL AT 3 M								
NO.	FREQ. (MHz)	EMISSION LEVEL (dBuV/m)	LIMIT (dBuV/m)	MARGIN (dB)	ANTENNA HEIGHT (m)	TABLE ANGLE (Degree)	RAW VALUE (dBuV)	CORRECTION FACTOR (dB/m)
1	*5825.00	100.9 PK			1.11 V	73	62.30	38.60
2	*5825.00	90.9 AV			1.11 V	73	52.30	38.60
3	#5850.00	62.0 PK	80.9	-18.9	1.11 V	73	23.40	38.60
4	#5850.00	45.8 AV	70.9	-25.1	1.11 V	73	7.20	38.60
5	11650.00	59.6 PK	74.0	-14.4	1.34 V	243	10.90	48.70
6	11650.00	46.2 AV	54.0	-7.8	1.34 V	243	-2.50	48.70

- REMARKS:**
1. Emission level (dBuV/m) = Raw Value (dBuV) + Correction Factor (dB/m).
 2. Correction Factor (dB/m) = Antenna Factor (dB/m) + Cable Factor (dB).
 3. The other emission levels were very low against the limit.
 4. Margin value = Emission level – Limit value.
 5. “ * “: Fundamental frequency.
 6. The limit value is defined as per 15.247.
 7. "#":The radiated frequency is out the restricted band.



A D T

802.11n (20MHz)

EUT TEST CONDITION		MEASUREMENT DETAIL	
CHANNEL	Channel 149	FREQUENCY RANGE	1 ~ 40GHz
INPUT POWER (SYSTEM)	120Vac, 60Hz	DETECTOR FUNCTION	Peak (PK) Average (AV)
ENVIRONMENTAL CONDITIONS	25deg. C, 65%RH	TESTED BY	David Huang

ANTENNA POLARITY & TEST DISTANCE: HORIZONTAL AT 3 M								
NO.	FREQ. (MHz)	EMISSION LEVEL (dBuV/m)	LIMIT (dBuV/m)	MARGIN (dB)	ANTENNA HEIGHT (m)	TABLE ANGLE (Degree)	RAW VALUE (dBuV)	CORRECTION FACTOR (dB/m)
1	#5725.00	70.2 PK	87.6	-17.4	1.09 H	160	31.80	38.40
2	#5725.00	51.1 AV	77.7	-26.6	1.09 H	160	12.70	38.40
3	*5745.00	107.6 PK			1.35 H	160	69.20	38.40
4	*5745.00	97.7 AV			1.35 H	160	59.30	38.40
5	11490.00	62.8 PK	74.0	-11.2	1.25 H	97	13.80	49.00
6	11490.00	49.7 AV	54.0	-4.3	1.25 H	97	0.70	49.00
ANTENNA POLARITY & TEST DISTANCE: VERTICAL AT 3 M								
NO.	FREQ. (MHz)	EMISSION LEVEL (dBuV/m)	LIMIT (dBuV/m)	MARGIN (dB)	ANTENNA HEIGHT (m)	TABLE ANGLE (Degree)	RAW VALUE (dBuV)	CORRECTION FACTOR (dB/m)
1	#5725.00	74.2 PK	86.8	-12.6	1.26 V	258	35.80	38.40
2	#5725.00	54.7 AV	77.1	-22.4	1.26 V	258	16.30	38.40
3	*5745.00	106.8 PK			1.39 V	260	68.40	38.40
4	*5745.00	97.1 AV			1.39 V	260	58.70	38.40
5	11490.00	62.9 PK	74.0	-11.1	1.30 V	247	13.90	49.00
6	11490.00	48.6 AV	54.0	-5.4	1.30 V	247	-0.40	49.00

- REMARKS:**
1. Emission level (dBuV/m) = Raw Value (dBuV) + Correction Factor (dB/m).
 2. Correction Factor (dB/m) = Antenna Factor (dB/m) + Cable Factor (dB).
 3. The other emission levels were very low against the limit.
 4. Margin value = Emission level – Limit value.
 5. “ * “: Fundamental frequency.
 6. The limit value is defined as per 15.247.
 7. "#":The radiated frequency is out the restricted band.



A D T

EUT TEST CONDITION		MEASUREMENT DETAIL	
CHANNEL	Channel 157	FREQUENCY RANGE	1 ~ 40GHz
INPUT POWER (SYSTEM)	120Vac, 60Hz	DETECTOR FUNCTION	Peak (PK) Average (AV)
ENVIRONMENTAL CONDITIONS	25deg. C, 65%RH	TESTED BY	David Huang

ANTENNA POLARITY & TEST DISTANCE: HORIZONTAL AT 3 M								
NO.	FREQ. (MHz)	EMISSION LEVEL (dBuV/m)	LIMIT (dBuV/m)	MARGIN (dB)	ANTENNA HEIGHT (m)	TABLE ANGLE (Degree)	RAW VALUE (dBuV)	CORRECTION FACTOR (dB/m)
1	*5785.00	107.4 PK			1.00 H	162	68.90	38.50
2	*5785.00	97.4 AV			1.00 H	162	58.90	38.50
3	11570.00	62.5 PK	74.0	-11.5	1.15 H	243	13.70	48.80
4	11570.00	49.1 AV	54.0	-4.9	1.15 H	243	0.30	48.80
5	#17355.00	61.5 PK	87.4	-25.9	1.20 H	243	8.90	52.60
6	#17355.00	50.4 AV	77.4	-27.0	1.20 H	243	-2.20	52.60
ANTENNA POLARITY & TEST DISTANCE: VERTICAL AT 3 M								
NO.	FREQ. (MHz)	EMISSION LEVEL (dBuV/m)	LIMIT (dBuV/m)	MARGIN (dB)	ANTENNA HEIGHT (m)	TABLE ANGLE (Degree)	RAW VALUE (dBuV)	CORRECTION FACTOR (dB/m)
1	#5733.00	58.0 PK	88.6	-30.6	1.61 V	123	19.60	38.40
2	#5733.00	47.6 AV	78.6	-31.0	1.61 V	123	9.20	38.40
3	*5785.00	108.6 PK			1.22 V	85	70.10	38.50
4	*5785.00	98.6 AV			1.22 V	85	60.10	38.50
5	11570.00	61.7 PK	74.0	-12.3	1.43 V	91	12.90	48.80
6	11570.00	47.0 AV	54.0	-7.0	1.43 V	91	-1.80	48.80

- REMARKS:**
1. Emission level (dBuV/m) = Raw Value (dBuV) + Correction Factor (dB/m).
 2. Correction Factor (dB/m) = Antenna Factor (dB/m) + Cable Factor (dB).
 3. The other emission levels were very low against the limit.
 4. Margin value = Emission level – Limit value.
 5. “ * “: Fundamental frequency.
 6. The limit value is defined as per 15.247.
 7. "#":The radiated frequency is out the restricted band.



A D T

EUT TEST CONDITION		MEASUREMENT DETAIL	
CHANNEL	Channel 165	FREQUENCY RANGE	1 ~ 40GHz
INPUT POWER (SYSTEM)	120Vac, 60Hz	DETECTOR FUNCTION	Peak (PK) Average (AV)
ENVIRONMENTAL CONDITIONS	25deg. C, 65%RH	TESTED BY	David Huang

ANTENNA POLARITY & TEST DISTANCE: HORIZONTAL AT 3 M								
NO.	FREQ. (MHz)	EMISSION LEVEL (dBuV/m)	LIMIT (dBuV/m)	MARGIN (dB)	ANTENNA HEIGHT (m)	TABLE ANGLE (Degree)	RAW VALUE (dBuV)	CORRECTION FACTOR (dB/m)
1	#5725.00	79.4 PK	85.7	-6.3	1.02 H	169	41.00	38.40
2	#5725.00	64.1 AV	76.5	-12.4	1.02 H	169	25.70	38.40
3	*5755.00	105.7 PK			1.01 H	168	67.20	38.50
4	*5755.00	96.5 AV			1.01 H	168	58.00	38.50
5	11510.00	59.4 PK	74.0	-14.6	1.00 H	244	10.40	49.00
6	11510.00	47.2 AV	54.0	-6.8	1.00 H	244	-1.80	49.00
ANTENNA POLARITY & TEST DISTANCE: VERTICAL AT 3 M								
NO.	FREQ. (MHz)	EMISSION LEVEL (dBuV/m)	LIMIT (dBuV/m)	MARGIN (dB)	ANTENNA HEIGHT (m)	TABLE ANGLE (Degree)	RAW VALUE (dBuV)	CORRECTION FACTOR (dB/m)
1	*5825.00	106.7 PK			1.00 V	87	68.10	38.60
2	*5825.00	96.5 AV			1.00 V	87	57.90	38.60
3	#5850.00	56.8 PK	86.7	-29.9	1.00 V	226	18.20	38.60
4	#5850.00	42.9 AV	76.5	-33.6	1.00 V	226	4.30	38.60
5	11650.00	61.1 PK	74.0	-12.9	1.00 V	186	12.40	48.70
6	11650.00	47.3 AV	54.0	-6.7	1.00 V	186	-1.40	48.70

- REMARKS:**
1. Emission level (dBuV/m) = Raw Value (dBuV) + Correction Factor (dB/m).
 2. Correction Factor (dB/m) = Antenna Factor (dB/m) + Cable Factor (dB).
 3. The other emission levels were very low against the limit.
 4. Margin value = Emission level – Limit value.
 5. “ * “: Fundamental frequency.
 6. The limit value is defined as per 15.247.
 7. "#":The radiated frequency is out the restricted band.



A D T

802.11n (40MHz)

EUT TEST CONDITION		MEASUREMENT DETAIL	
CHANNEL	Channel 151	FREQUENCY RANGE	1 ~ 40GHz
INPUT POWER (SYSTEM)	120Vac, 60Hz	DETECTOR FUNCTION	Peak (PK) Average (AV)
ENVIRONMENTAL CONDITIONS	25deg. C, 65%RH	TESTED BY	David Huang

ANTENNA POLARITY & TEST DISTANCE: HORIZONTAL AT 3 M								
NO.	FREQ. (MHz)	EMISSION LEVEL (dBuV/m)	LIMIT (dBuV/m)	MARGIN (dB)	ANTENNA HEIGHT (m)	TABLE ANGLE (Degree)	RAW VALUE (dBuV)	CORRECTION FACTOR (dB/m)
1	#5725.00	79.4 PK	85.7	-6.3	1.02 H	169	41.00	38.40
2	#5725.00	64.1 AV	76.5	-12.4	1.02 H	169	25.70	38.40
3	*5755.00	105.7 PK			1.01 H	168	67.20	38.50
4	*5755.00	96.5 AV			1.01 H	168	58.00	38.50
5	11510.00	59.4 PK	74.0	-14.6	1.00 H	244	10.40	49.00
6	11510.00	47.2 AV	54.0	-6.8	1.00 H	244	-1.80	49.00
ANTENNA POLARITY & TEST DISTANCE: VERTICAL AT 3 M								
NO.	FREQ. (MHz)	EMISSION LEVEL (dBuV/m)	LIMIT (dBuV/m)	MARGIN (dB)	ANTENNA HEIGHT (m)	TABLE ANGLE (Degree)	RAW VALUE (dBuV)	CORRECTION FACTOR (dB/m)
1	#5725.00	73.3 PK	86.8	-13.5	1.23 V	217	34.90	38.40
2	#5725.00	61.4 AV	76.6	-15.2	1.23 V	217	23.00	38.40
3	*5755.00	106.8 PK			1.38 V	256	68.30	38.50
4	*5755.00	96.6 AV			1.38 V	256	58.10	38.50
5	11510.00	61.1 PK	74.0	-12.9	1.21 V	252	12.10	49.00
6	11510.00	47.6 AV	54.0	-6.4	1.21 V	252	-1.40	49.00

- REMARKS:**
1. Emission level (dBuV/m) = Raw Value (dBuV) + Correction Factor (dB/m).
 2. Correction Factor (dB/m) = Antenna Factor (dB/m) + Cable Factor (dB).
 3. The other emission levels were very low against the limit.
 4. Margin value = Emission level – Limit value.
 5. “ * “: Fundamental frequency.
 6. The limit value is defined as per 15.247.
 7. “#”:The radiated frequency is out the restricted band.



A D T

EUT TEST CONDITION		MEASUREMENT DETAIL	
CHANNEL	Channel 159	FREQUENCY RANGE	1 ~ 40GHz
INPUT POWER (SYSTEM)	120Vac, 60Hz	DETECTOR FUNCTION	Peak (PK) Average (AV)
ENVIRONMENTAL CONDITIONS	25deg. C, 65%RH	TESTED BY	David Huang

ANTENNA POLARITY & TEST DISTANCE: HORIZONTAL AT 3 M								
NO.	FREQ. (MHz)	EMISSION LEVEL (dBuV/m)	LIMIT (dBuV/m)	MARGIN (dB)	ANTENNA HEIGHT (m)	TABLE ANGLE (Degree)	RAW VALUE (dBuV)	CORRECTION FACTOR (dB/m)
1	*5795.00	105.4 PK			1.00 H	158	66.90	38.50
2	*5795.00	95.5 AV			1.00 H	158	57.00	38.50
3	#5850.00	55.9 PK	85.4	-29.5	1.00 H	162	17.30	38.60
4	#5850.00	44.4 AV	75.5	-31.1	1.00 H	162	5.80	38.60
5	11590.00	59.4 PK	74.0	-14.6	1.00 H	260	10.60	48.80
6	11590.00	47.1 AV	54.0	-6.9	1.00 H	260	-1.70	48.80
ANTENNA POLARITY & TEST DISTANCE: VERTICAL AT 3 M								
NO.	FREQ. (MHz)	EMISSION LEVEL (dBuV/m)	LIMIT (dBuV/m)	MARGIN (dB)	ANTENNA HEIGHT (m)	TABLE ANGLE (Degree)	RAW VALUE (dBuV)	CORRECTION FACTOR (dB/m)
1	*5795.00	104.0 PK			1.02 V	268	65.50	38.50
2	*5795.00	94.2 AV			1.02 V	268	55.70	38.50
3	#5850.00	53.9 PK	84.0	-30.1	1.23 V	225	15.30	38.60
4	#5850.00	42.3 AV	74.2	-31.9	1.23 V	225	3.70	38.60
5	11590.00	58.6 PK	74.0	-15.4	1.00 V	264	9.80	48.80
6	11590.00	46.5 AV	54.0	-7.5	1.00 V	264	-2.30	48.80

- REMARKS:**
1. Emission level (dBuV/m) = Raw Value (dBuV) + Correction Factor (dB/m).
 2. Correction Factor (dB/m) = Antenna Factor (dB/m) + Cable Factor (dB).
 3. The other emission levels were very low against the limit.
 4. Margin value = Emission level – Limit value.
 5. “ * “: Fundamental frequency.
 6. The limit value is defined as per 15.247.
 7. “#“: The radiated frequency is out the restricted band.



A D T

BELOW 1GHz WORST-CASE DATA : 802.11n (20MHz)

EUT TEST CONDITION		MEASUREMENT DETAIL	
CHANNEL	Channel 157	FREQUENCY RANGE	Below 1000MHz
INPUT POWER (SYSTEM)	120Vac, 60Hz	DETECTOR FUNCTION	Quasi-Peak
ENVIRONMENTAL CONDITIONS	25deg. C, 65%RH	TESTED BY	Kay Wu

ANTENNA POLARITY & TEST DISTANCE: HORIZONTAL AT 3 M								
NO.	FREQ. (MHz)	EMISSION LEVEL (dBuV/m)	LIMIT (dBuV/m)	MARGIN (dB)	ANTENNA HEIGHT (m)	TABLE ANGLE (Degree)	RAW VALUE (dBuV)	CORRECTION FACTOR (dB/m)
1	78.51	38.2 QP	40.0	-1.8	2.00 H	337	28.60	9.60
2	140.72	28.6 QP	43.5	-14.9	2.00 H	286	14.50	14.10
3	216.00	25.2 QP	43.5	-18.3	1.50 H	319	14.00	11.20
4	325.43	34.1 QP	46.0	-11.9	1.00 H	343	18.50	15.60
5	482.92	24.2 QP	46.0	-21.8	2.00 H	292	4.50	19.70
6	558.75	25.3 QP	46.0	-20.7	1.50 H	259	3.80	21.50
ANTENNA POLARITY & TEST DISTANCE: VERTICAL AT 3 M								
NO.	FREQ. (MHz)	EMISSION LEVEL (dBuV/m)	LIMIT (dBuV/m)	MARGIN (dB)	ANTENNA HEIGHT (m)	TABLE ANGLE (Degree)	RAW VALUE (dBuV)	CORRECTION FACTOR (dB/m)
1	78.51	34.0 QP	40.0	-6.0	3.00 V	253	24.40	9.60
2	142.67	20.5 QP	43.5	-23.0	3.00 V	22	6.30	14.20
3	323.49	23.4 QP	46.0	-22.6	1.00 V	37	7.90	15.50
4	496.53	20.1 QP	46.0	-25.9	1.50 V	331	0.00	20.10
5	667.63	21.6 QP	46.0	-24.4	2.50 V	292	-2.00	23.60
6	704.57	22.2 QP	46.0	-23.8	3.00 V	352	-1.90	24.10

- REMARKS:**
1. Emission level (dBuV/m) = Raw Value (dBuV) + Correction Factor (dB/m).
 2. Correction Factor (dB/m) = Antenna Factor (dB/m) + Cable Factor (dB).
 3. The other emission levels were very low against the limit.
 4. Margin value = Emission level – Limit value.



5.2 CONDUCTED EMISSION MEASUREMENT

5.2.1 LIMITS OF CONDUCTED EMISSION MEASUREMENT

FREQUENCY OF EMISSION (MHz)	CONDUCTED LIMIT (dBµV)	
	Quasi-peak	Average
0.15 ~ 0.5	66 to 56	56 to 46
0.5 ~ 5	56	46
5 ~ 30	60	50

- NOTE:** 1. The lower limit shall apply at the transition frequencies.
 2. The limit decreases in line with the logarithm of the frequency in the range of 0.15 to 0.50MHz.
 3. All emanations from a class A/B digital device or system, including any network of conductors and apparatus connected thereto, shall not exceed the level of field strengths specified above.

5.2.2 TEST INSTRUMENTS

DESCRIPTION & MANUFACTURER	MODEL NO.	SERIAL NO.	DATE OF CALIBRATION	DUE DATE OF CALIBRATION
Test Receiver ROHDE & SCHWARZ	ESCS30	100291	Nov. 23, 2011	Nov. 22, 2012
RF signal cable Woken	5D-FB	Cable-HYC01-01	Dec. 22, 2011	Dec. 21, 2012
LISN ROHDE & SCHWARZ	ESH3-Z5	100312	Jul. 07, 2011	Jul. 06, 2012
LISN ROHDE & SCHWARZ	ESH3-Z5	835239/001	Feb. 22, 2011	Feb. 21, 2012
Software ADT	ADT_Cond_ V7.3.7	NA	NA	NA

- NOTE:** 1. The calibration interval of the above test instruments is 12 months and the calibrations are traceable to NML/ROC and NIST/USA.
 2. The test was performed in HwaYa Shielded Room 1.
 3. The VCCI Site Registration No. is C-2040.



A D T

5.2.3 TEST PROCEDURES

- a. The EUT was placed 0.4 meters from the conducting wall of the shielded room with EUT being connected to the power mains through a line impedance stabilization network (LISN). Other support units were connected to the power mains through another LISN. The two LISNs provide 50 ohm/ 50uH of coupling impedance for the measuring instrument.
- b. Both lines of the power mains connected to the EUT were checked for maximum conducted interference.
- c. The frequency range from 150kHz to 30MHz was searched. Emission levels under (Limit - 20dB) was not recorded.

NOTE: All modes of operation were investigated and the worst-case emissions are reported.

5.2.4 DEVIATION FROM TEST STANDARD

No deviation.

5.2.5 TEST SETUP

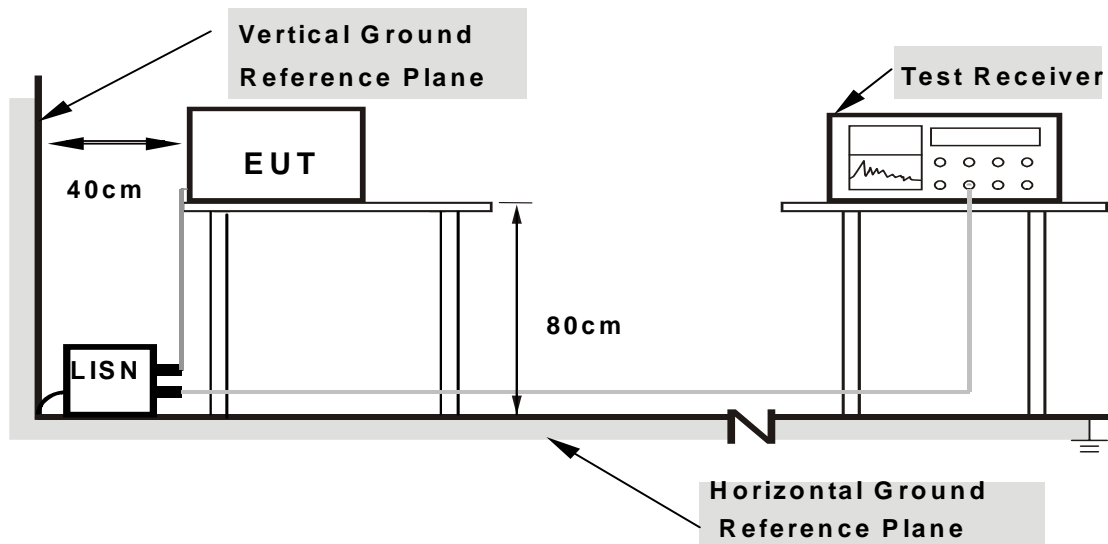

Note: 1.Support units were connected to second LISN.

2.Both of LISNs (AMN) are 80 cm from EUT and at least 80 from other units and other metal planes

For the actual test configuration, please refer to the attached file (Test Setup Photo).

5.2.6 EUT OPERATING CONDITIONS

Same as 4.1.6

5.2.7 TEST RESULTS

CONDUCTED WORST-CASE DATA : 802.11n (20MHz)

PHASE	Line 1	6dB BANDWIDTH	9kHz
--------------	--------	----------------------	------

No	Freq. [MHz]	Corr.	Reading Value		Emission Level		Limit		Margin	
		Factor (dB)	Q.P. [dB (uV)]	AV. [dB (uV)]	Q.P. [dB (uV)]	AV. [dB (uV)]	Q.P. [dB (uV)]	AV. [dB (uV)]	Q.P. (dB)	AV. (dB)
1	0.162	0.12	46.23	32.83	46.35	32.95	65.38	55.38	-19.03	-22.43
2	0.271	0.12	48.57	43.74	48.69	43.86	61.08	51.08	-12.39	-7.22
3	0.463	0.12	39.62	26.13	39.74	26.25	56.65	46.65	-16.90	-20.39
4	0.920	0.15	35.51	22.44	35.66	22.59	56.00	46.00	-20.34	-23.41
5	1.145	0.16	33.93	22.38	34.09	22.54	56.00	46.00	-21.91	-23.46
6	25.227	1.38	24.79	23.14	26.17	24.52	60.00	50.00	-33.83	-25.48

- REMARKS:**
1. Q.P. and AV. are abbreviations of quasi-peak and average individually.
 2. "-": The Quasi-peak reading value also meets average limit and measurement with the average detector is unnecessary.
 3. The emission levels of other frequencies were very low against the limit.
 4. Margin value = Emission level - Limit value
 5. Correction factor = Insertion loss + Cable loss
 6. Emission Level = Correction Factor + Reading Value.

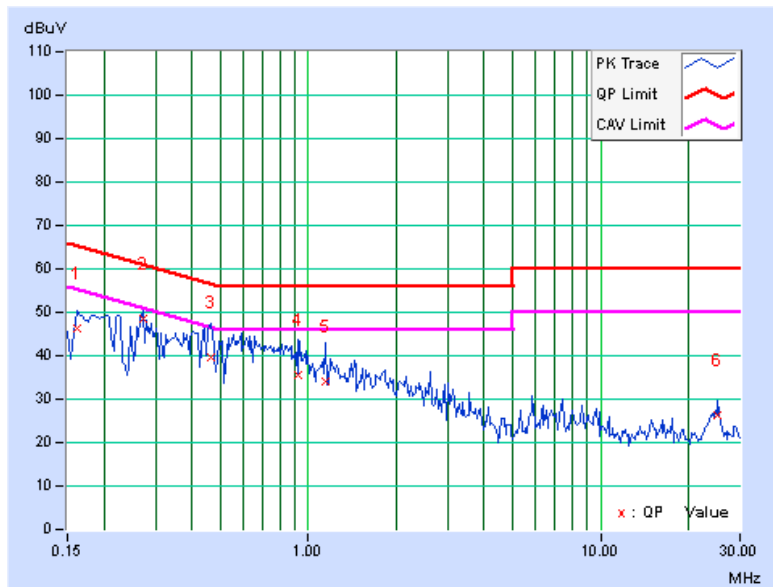

PHASE	Line 2	6dB BANDWIDTH	9kHz
-------	--------	---------------	------

No	Freq. [MHz]	Corr. Factor (dB)	Reading Value [dB (uV)]		Emission Level [dB (uV)]		Limit [dB (uV)]		Margin (dB)	
			Q.P.	AV.	Q.P.	AV.	Q.P.	AV.	Q.P.	AV.
1	0.150	0.12	49.16	31.93	49.28	32.05	66.00	56.00	-16.72	-23.95
2	0.271	0.13	48.55	43.72	48.68	43.85	61.08	51.08	-12.40	-7.23
3	0.474	0.14	39.41	25.82	39.55	25.96	56.44	46.44	-16.88	-20.47
4	0.545	0.15	40.39	33.81	40.54	33.96	56.00	46.00	-15.46	-12.04
5	0.908	0.17	34.82	22.24	34.99	22.41	56.00	46.00	-21.01	-23.59
6	25.230	1.12	26.91	25.66	28.03	26.78	60.00	50.00	-31.97	-23.22

- REMARKS:**
1. Q.P. and AV. are abbreviations of quasi-peak and average individually.
 2. "-": The Quasi-peak reading value also meets average limit and measurement with the average detector is unnecessary.
 3. The emission levels of other frequencies were very low against the limit.
 4. Margin value = Emission level - Limit value
 5. Correction factor = Insertion loss + Cable loss
 6. Emission Level = Correction Factor + Reading Value.

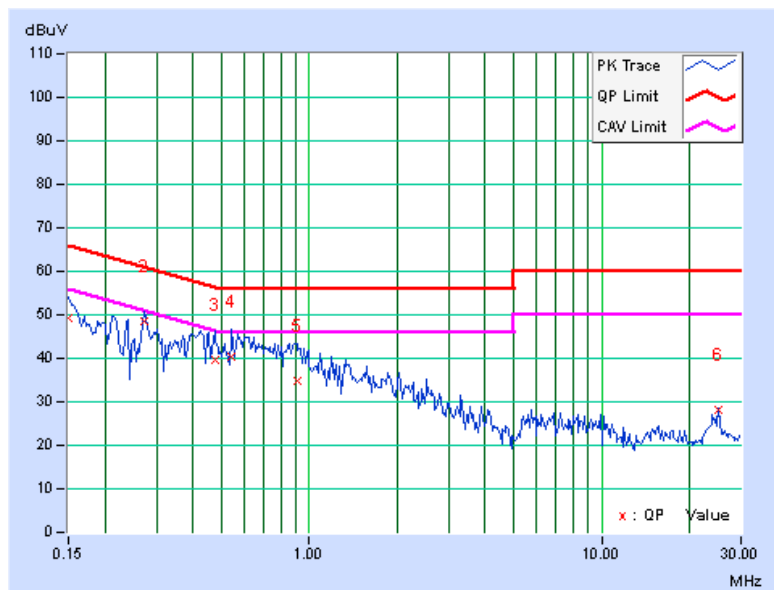

5.3 6dB BANDWIDTH MEASUREMENT

5.3.1 LIMITS OF 6dB BANDWIDTH MEASUREMENT

The minimum of 6dB Bandwidth Measurement is 0.5MHz.

5.3.2 TEST SETUP

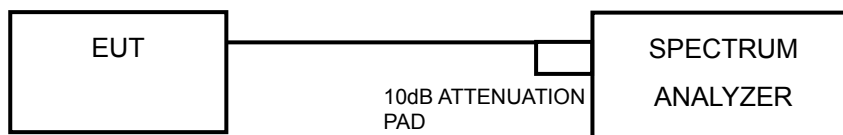

5.3.3 TEST INSTRUMENTS

Refer to section 4.1.2 to get information of above instrument.

5.3.4 TEST PROCEDURE

1. Set resolution bandwidth (RBW) = approximately 1% of the emission bandwidth
2. Set the video bandwidth (VBW) $\geq 3 \times$ RBW, Detector = Peak.
3. Trace mode = max hold.
4. Sweep = auto couple.
5. Measure the maximum width of the emission that is constrained by the frequencies associated with the two amplitude points (upper and lower) that are attenuated by 6 dB relative to the maximum level measured in the fundamental emission

5.3.5 DEVIATION FROM TEST STANDARD

No deviation.

5.3.6 EUT OPERATING CONDITIONS

The software provided by client to enable the EUT under transmission condition continuously at lowest, middle and highest channel frequencies individually.



5.3.7 TEST RESULTS

802.11a

CHANNEL	CHANNEL FREQUENCY (MHz)	6dB BANDWIDTH (MHz)	MINIMUM LIMIT (MHz)	PASS / FAIL
149	5745	16.48	0.5	PASS
157	5785	16.47	0.5	PASS
165	5825	16.59	0.5	PASS

802.11n (20MHz)

CHANNEL	CHANNEL FREQUENCY (MHz)	6dB BANDWIDTH (MHz)			MINIMUM LIMIT (MHz)	PASS / FAIL
		CHAIN 0	CHAIN 1	CHAIN 2		
149	5745	17.68	17.65	17.63	0.5	PASS
157	5785	17.69	17.67	17.71	0.5	PASS
165	5825	17.64	17.73	17.66	0.5	PASS

802.11n (40MHz)

CHANNEL	CHANNEL FREQUENCY (MHz)	6dB BANDWIDTH (MHz)			MINIMUM LIMIT (MHz)	PASS / FAIL
		CHAIN 0	CHAIN 1	CHAIN 2		
151	5755	36.21	36.20	36.21	0.5	PASS
159	5795	36.28	36.20	36.25	0.5	PASS

5.4 CONDUCTED OUTPUT POWER

5.4.1 LIMITS OF CONDUCTED OUTPUT POWER MEASUREMENT

For systems using digital modulation in the 5725 –5850 MHz bands: 1 Watt (30dBm)

5.4.2 TEST SETUP

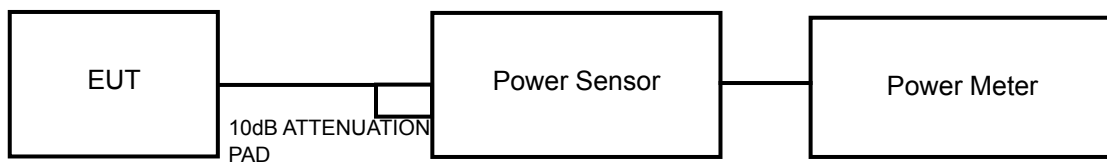

5.4.3 INSTRUMENTS

Refer to section 4.1.2 to get information of above instrument.

5.4.4 TEST PROCEDURES

A power sensor was used on the output port of the EUT. A power meter was used to read the response of the power sensor. Record the power level.

5.4.5 DEVIATION FROM TEST STANDARD

No deviation.

5.4.6 EUT OPERATING CONDITIONS

Same as Item 4.3.6.

5.4.7 TEST RESULTS

802.11a

CHANNEL	CHANNEL FREQUENCY (MHz)	POWER OUTPUT (mW)	POWER OUTPUT (dBm)	POWER LIMIT (dBm)	PASS/FAIL
149	5745	169.8	22.3	30	PASS
157	5785	166.0	22.2	30	PASS
165	5825	158.5	22.0	30	PASS

802.11n (20MHz)

CHAN.	CHAN. FREQ. (MHz)	POWER OUTPUT (dBm)			TOTAL POWER (mW)	TOTAL POWER (dBm)	POWER LIMIT (dBm)	PASS / FAIL
		CHAIN 0	CHAIN 1	CHAIN 2				
149	5745	21.1	21.3	20.9	386.7	25.9	28.2	PASS
157	5785	21.0	21.3	20.8	381.0	25.8	28.2	PASS
165	5825	21.1	21.4	20.8	387.1	25.9	28.2	PASS

Directional gain = $3.0\text{dBi} + 10\log(3) = 7.8\text{dBi} > 6\text{dBi}$, so the conducted power limit shall be reduced to $30 - (7.8 - 6) = 28.2\text{dBm}$

802.11n (40MHz)

CHAN.	CHAN. FREQ. (MHz)	POWER OUTPUT (dBm)			TOTAL POWER (mW)	TOTAL POWER (dBm)	POWER LIMIT (dBm)	PASS / FAIL
		CHAIN 0	CHAIN 1	CHAIN 2				
151	5755	21.1	21.3	20.8	383.9	25.8	28.2	PASS
159	5795	21.7	21.9	21.4	440.8	26.4	28.2	PASS

Directional gain = $3.0\text{dBi} + 10\log(3) = 7.8\text{dBi} > 6\text{dBi}$, so the conducted power limit shall be reduced to $30 - (7.8 - 6) = 28.2\text{dBm}$

5.5 POWER SPECTRAL DENSITY MEASUREMENT

5.5.1 LIMITS OF POWER SPECTRAL DENSITY MEASUREMENT

The Maximum of Power Spectral Density Measurement is 8dBm.

5.5.2 TEST SETUP

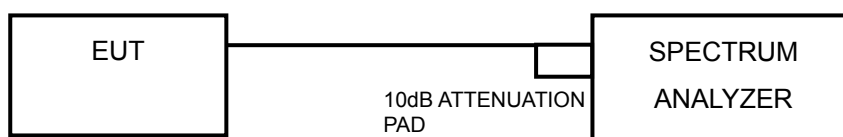

5.5.3 TEST INSTRUMENTS

Refer to section 4.1.2 to get information of above instrument.

5.5.4 TEST PROCEDURE.

1. Set the RBW = 100 kHz, VBW = 300 kHz, Detector = peak.
2. Sweep time = auto couple, Trace mode = max hold, allow trace to fully stabilize.
3. Use the peak marker function to determine the maximum power level in any 100 kHz band segment within the fundamental EBW.
4. Scale the observed power level to an equivalent value in 3 kHz by adjusting (reducing) the measured power by a bandwidth correction factor (BWCF) where $BWCF = 10\log(3 \text{ kHz}/100\text{kHz})$

5.5.5 DEVIATION FROM TEST STANDARD

No deviation.

5.5.6 EUT OPERATING CONDITION

Same as Item 5.3.6.



A D T

5.5.7 TEST RESULTS

802.11a

Channel	FREQ. (MHz)	PSD (dBm/100kHz)	PSD (dBm/3kHz)	Limit (dBm/3kHz)	PASS /FAIL
149	5745	3.35	-11.88	8	PASS
157	5785	3.35	-11.88	8	PASS
165	5825	2.99	-12.24	8	PASS

802.11n (20MHz)

TX chain	Channel	FREQ. (MHz)	PSD (dBm/100kHz)	PSD (dBm/3kHz)	10 log (N=2) dB	Total PSD (dBm/3kHz)	Limit (dBm/3kHz)	PASS /FAIL
0	149	5745	1.71	-13.52	4.77	-8.75	6.2	PASS
	157	5785	1.53	-13.70	4.77	-8.93	6.2	PASS
	165	5825	1.52	-13.71	4.77	-8.94	6.2	PASS
1	149	5745	2.63	-12.60	4.77	-7.83	6.2	PASS
	157	5785	2.53	-12.70	4.77	-7.93	6.2	PASS
	165	5825	2.52	-12.71	4.77	-7.94	6.2	PASS
2	149	5745	2.25	-12.98	4.77	-8.21	6.2	PASS
	157	5785	2.01	-13.22	4.77	-8.45	6.2	PASS
	165	5825	1.94	-13.29	4.77	-8.52	6.2	PASS

Directional gain = $3\text{dBi} + 10\log(3) = 7.8\text{dBi} > 6\text{dBi}$, so the power spectral density limit shall be reduced to $8 - (7.8 - 6) = 6.2\text{dBm}$

802.11n (40MHz)

TX chain	Channel	FREQ. (MHz)	PSD (dBm/100kHz)	PSD (dBm/3kHz)	10 log (N=2) dB	Total PSD (dBm/3kHz)	Limit (dBm/3kHz)	PASS /FAIL
0	151	5755	-1.57	-16.80	4.77	-12.03	6.2	PASS
	159	5795	-1.06	-16.29	4.77	-11.52	6.2	PASS
1	151	5755	-1.29	-16.52	4.77	-11.75	6.2	PASS
	159	5795	-0.77	-16.00	4.77	-11.23	6.2	PASS
2	151	5755	-0.97	-16.20	4.77	-11.43	6.2	PASS
	159	5795	-0.33	-15.56	4.77	-10.79	6.2	PASS

Directional gain = $3\text{dBi} + 10\log(3) = 7.8\text{dBi} > 6\text{dBi}$, so the power spectral density limit shall be reduced to $8 - (7.8 - 6) = 6.2\text{dBm}$

5.6 CONDUCTED EMISSION MEASUREMENT

5.6.1 LIMITS OF BAND EDGES MEASUREMENT

Below -20dB of the highest emission level of operating band (in 100kHz Resolution Bandwidth).

5.6.2 TEST SETUP

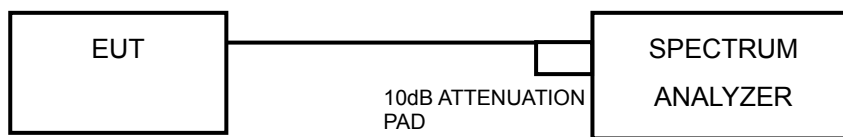

5.6.3 TEST INSTRUMENTS

Refer to section 4.1.2 to get information of above instrument.

5.6.4 TEST PROCEDURE

MEASUREMENT PROCEDURE REF

1. Set the RBW = 100 kHz.
2. Set the VBW \geq 300 kHz.
3. Detector = peak.
4. Sweep time = auto couple.
5. Trace mode = max hold.
6. Allow trace to fully stabilize.
7. Use the peak marker function to determine the maximum power level in any 100 kHz band segment within the fundamental EBW.



A D T

MEASUREMENT PROCEDURE OOBE

1. Set RBW = 100 kHz.
2. Set VBW \geq 300 kHz.
3. Set span to encompass the spectrum to be examined.
4. Detector = peak.
5. Trace Mode = max hold.
6. Sweep = auto couple.

5.6.5 DEVIATION FROM TEST STANDARD

No deviation.

5.6.6 EUT OPERATING CONDITION

Same as Item 5.3.6

5.6.7 TEST RESULTS

The conducted emission test is performed on each TX port of operating mode without summing or adding $10\log(N)$ since the limit is relative emission limit. Only worst data of each operating mode is presented.

The spectrum plots are attached on the following pages. D1 line indicates the highest level, and D2 line indicates the 20dB offset below D1. It shows compliance with the requirement in part 15.247(d).

802.11a

CH 149

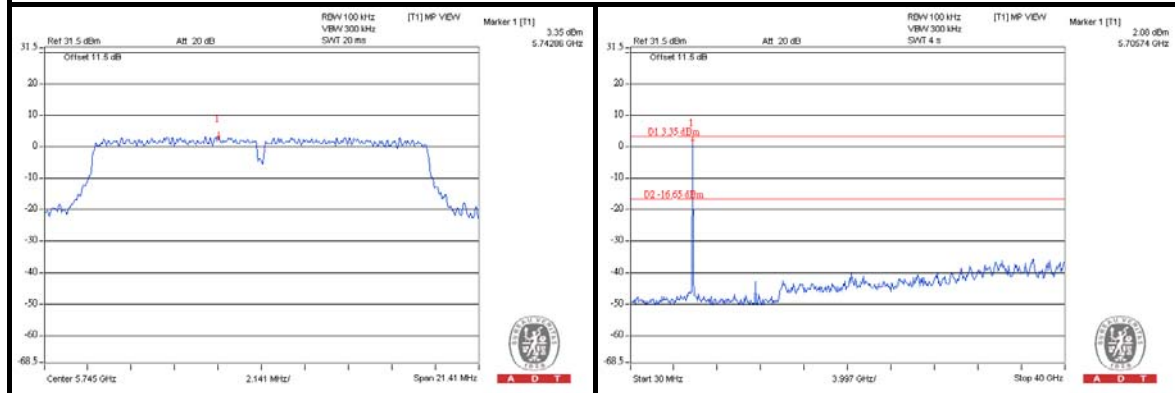

CH 157

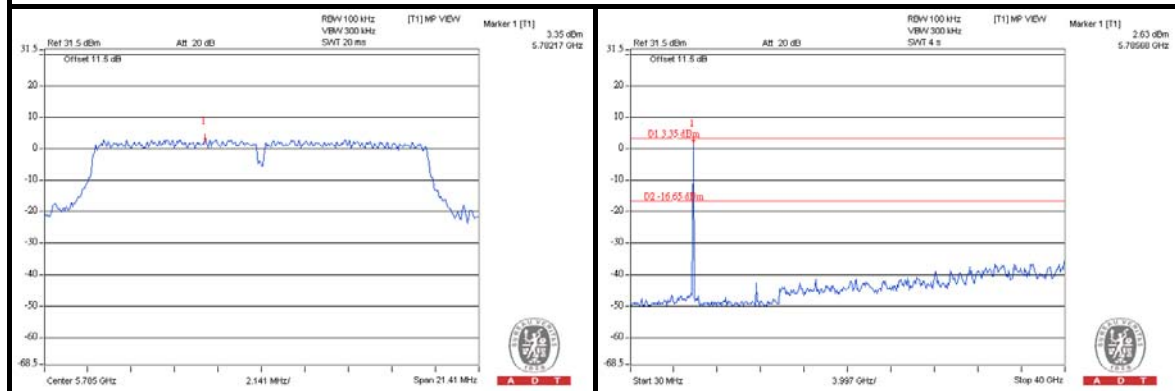

CH 165

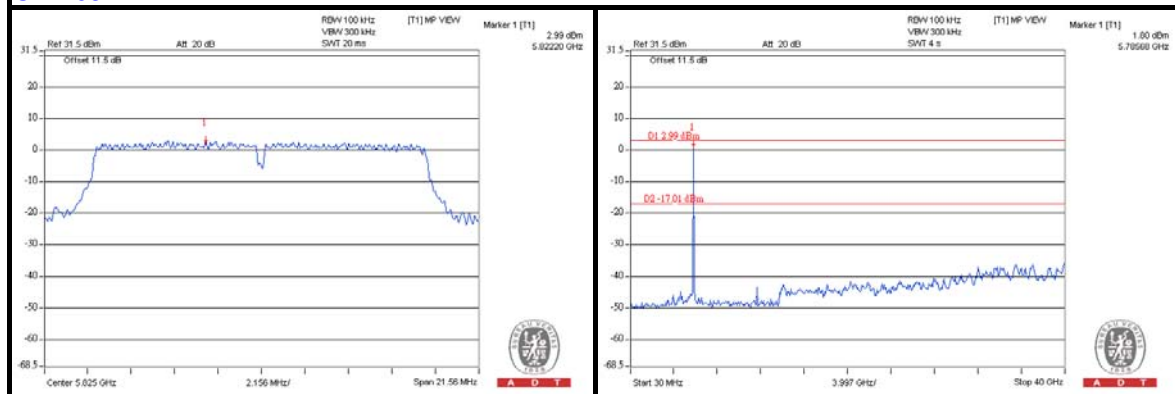

802.11n (20MHz)

CH 149

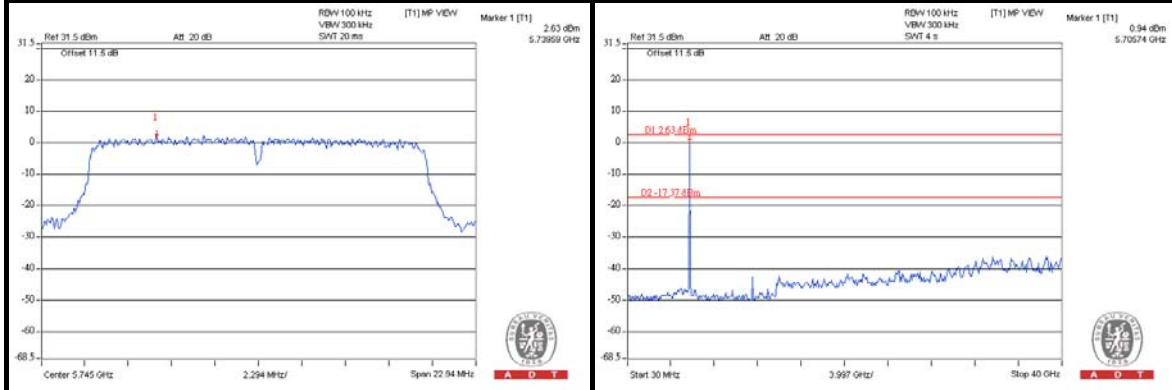

CH 157

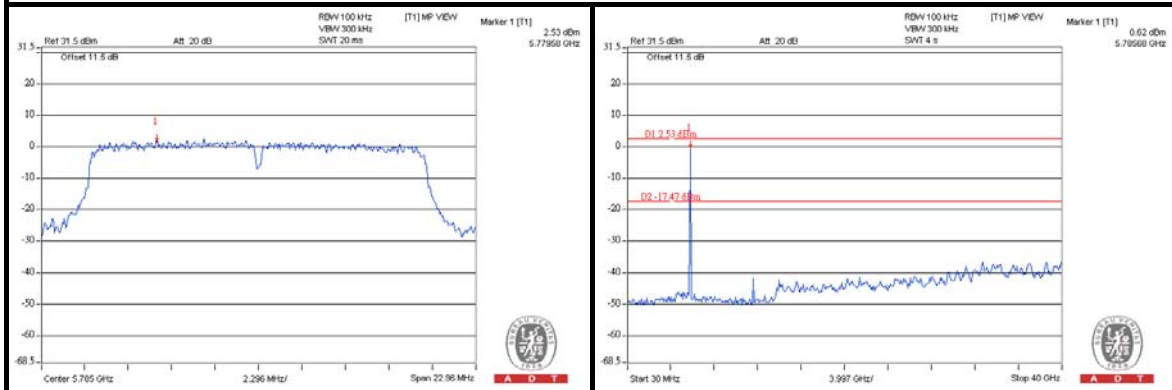

CH 165

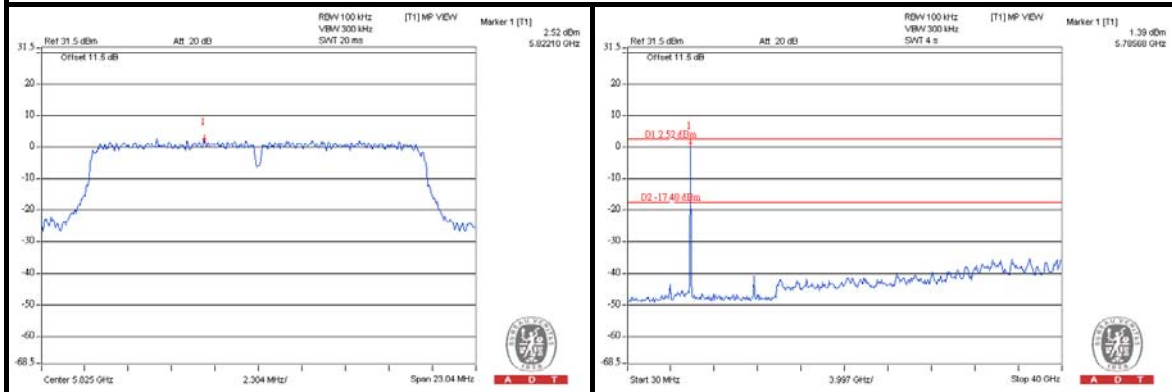

802.11n (40MHz)

CH 151

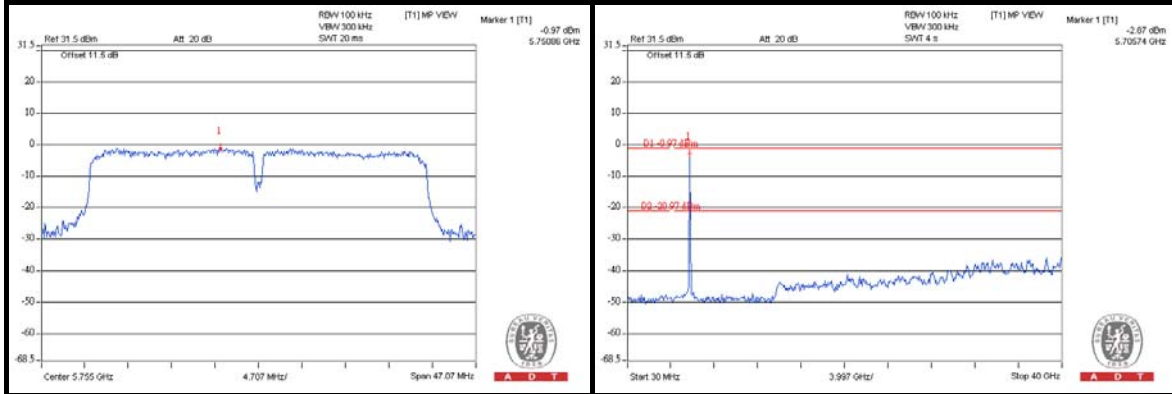

CH 159

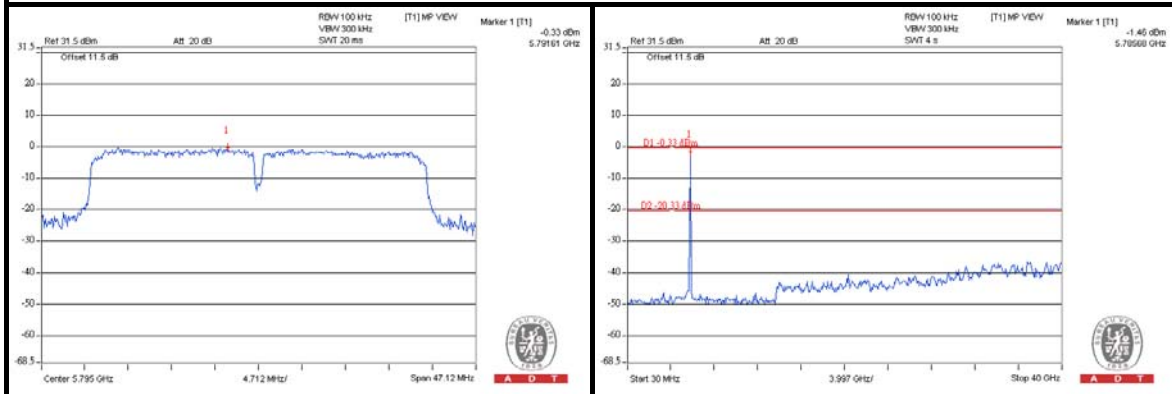



A D T

6. PHOTOGRAPHS OF THE TEST CONFIGURATION

Please refer to the attached file (Test Setup Photo).



A D T

7. INFORMATION ON THE TESTING LABORATORIES

We, Bureau Veritas Consumer Products Services (H.K.) Ltd., Taoyuan Branch, were founded in 1988 to provide our best service in EMC, Radio, Telecom and Safety consultation. Our laboratories are accredited and approved according to ISO/IEC 17025.

Copies of accreditation and authorization certificates of our laboratories obtained from approval agencies can be downloaded from our web site: www.adt.com.tw/index.5.phtml.

If you have any comments, please feel free to contact us at the following:

Linko EMC/RF Lab

Tel: 886-2-26052180

Fax: 886-2-26051924

Hsin Chu EMC/RF Lab

Tel: 886-3-5935343

Fax: 886-3-5935342

Hwa Ya EMC/RF/Safety/Telecom Lab

Tel: 886-3-3183232

Fax: 886-3-3185050

Email: service.adt@tw.bureauveritas.com

Web Site: www.adt.com.tw

The address and road map of all our labs can be found in our web site also.



A D T

8. APPENDIX A - MODIFICATIONS RECORDERS FOR ENGINEERING CHANGES TO THE EUT BY THE LAB

No modifications were made to the EUT by the lab during the test.

---END---