



SPORTON International Inc.

No. 52, Hwa Ya 1st Rd., Kwei-Shan Hsiang, TaoYuan Hsien, Taiwan, R.O.C.
Ph: 886-3-327-3456 / FAX: 886-3-327-0973 / www.sporton.com.tw

FCC RADIO TEST REPORT

Applicant's company	NETGEAR, Inc.
Applicant Address	350 East Plumeria Drive, San Jose, California 95134-1911
FCC ID	PY311300171
Manufacturer's company	Ambit Microsystems (Shanghai) Ltd.
Manufacturer Address	No. 1925, Nanle Road, Songjiang Export Processing Zone, Shanghai, China

Product Name	Universal Dual Band WiFi Range Extender
Brand Name	NETGEAR
Model Name	WN2500RP
Test Rule Part(s)	47 CFR FCC Part 15 Subpart E § 15.407
Test Freq. Range	5150 ~ 5250MHz
Received Date	May 15, 2011
Final Test Date	Nov. 03, 2011
Submission Type	Original Equipment
Operating Mode	Master / Slave

Statement

Test result included is for the IEEE 802.11n and IEEE 802.11a (5150 ~ 5250MHz) of the product.

The test result in this report refers exclusively to the presented test model / sample.

Without written approval of SPORTON International Inc., the test report shall not be reproduced except in full.

The measurements and test results shown in this test report were made in accordance with the procedures and found in compliance with the limit given in ANSI C63.10-2009 and 47 CFR FCC Part 15 Subpart E.

The test equipment used to perform the test is calibrated and traceable to NML/ROC.





Table of Contents

1. CERTIFICATE OF COMPLIANCE	1
2. SUMMARY OF THE TEST RESULT	2
3. GENERAL INFORMATION	3
3.1. Product Details.....	3
3.2. Accessories.....	5
3.3. Table for Filed Antenna.....	5
3.4. Table for Carrier Frequencies	6
3.5. Table for Test Modes.....	6
3.6. Table for Testing Locations.....	7
3.7. Table for Supporting Units	7
3.8. Table for Parameters of Test Software Setting	8
3.9. Test Configurations	9
4. TEST RESULT	11
4.1. AC Power Line Conducted Emissions Measurement.....	11
4.2. 99% Occupied Bandwidth Measurement	15
4.3. Maximum Conducted Output Power Measurement.....	22
4.4. Power Spectral Density Measurement	25
4.5. Peak Excursion Measurement.....	31
4.6. Radiated Emissions Measurement	36
4.7. Band Edge Emissions Measurement	50
4.8. Frequency Stability Measurement	56
4.9. Antenna Requirements	58
5. LIST OF MEASURING EQUIPMENTS	59
6. TEST LOCATION.....	61
7. TAF CERTIFICATE OF ACCREDITATION	62
APPENDIX A. TEST PHOTOS	A1 ~ A6
APPENDIX B. MAXIMUM PERMISSIBLE EXPOSURE	B1 ~ B4
APPENDIX C. CO-LOCATION REPORT.....	C1 ~ C5



History of This Test Report

REPORT NO.	VERSION	DESCRIPTION	ISSUED DATE
FR1N1910AA	Rev. 01	Initial issue of report	Dec. 05, 2011



1. CERTIFICATE OF COMPLIANCE

Product Name : Universal Dual Band WIFI Range Extender
Brand Name : NETGEAR
Model Name : WN2500RP
Applicant : NETGEAR, Inc.
Test Rule Part(s) : 47 CFR FCC Part 15 Subpart E § 15.407

Sporton International as requested by the applicant to evaluate the EMC performance of the product sample received on May 15, 2011 would like to declare that the tested sample has been evaluated and found to be in compliance with the tested rule parts. The data recorded as well as the test configuration specified is true and accurate for showing the sample's EMC nature.

Jordan Hsiao 2011-12-5

Jordan Hsiao

SPORTON INTERNATIONAL INC.

2. SUMMARY OF THE TEST RESULT

Applied Standard: 47 CFR FCC Part 15 Subpart E				
Part	Rule Section	Description of Test	Result	Under Limit
4.1	15.207	AC Power Line Conducted Emissions	Complies	7.85 dB
4.2	15.407(a)	26dB Spectrum Bandwidth	Complies	-
4.3	15.407(a)	Maximum Conducted Output Power	Complies	0.13 dB
4.4	15.407(a)	Power Spectral Density	Complies	0.00 dB
4.5	15.407(a)	Peak Excursion	Complies	7.31 dB
4.6	15.407(b)	Radiated Emissions	Complies	2.35 dB
4.7	15.407(b)	Band Edge Emissions	Complies	0.08 dB
4.8	15.407(g)	Frequency Stability	Complies	-
4.9	15.203	Antenna Requirements	Complies	-

Test Items	Uncertainty	Remark
AC Power Line Conducted Emissions	±2.3dB	Confidence levels of 95%
Maximum Conducted Output Power	±0.5dB	Confidence levels of 95%
Power Spectral Density	±0.5dB	Confidence levels of 95%
Peak Excursion	±0.5dB	Confidence levels of 95%
26dB Spectrum Bandwidth / Frequency Stability	±8.5×10 ⁻⁸	Confidence levels of 95%
Radiated Emissions (9kHz~30MHz)	±0.8dB	Confidence levels of 95%
Radiated Emissions (30MHz~1000MHz)	±1.9dB	Confidence levels of 95%
Radiated / Band Edge Emissions (1GHz~18GHz)	±1.9dB	Confidence levels of 95%
Radiated Emissions (18GHz~40GHz)	±1.9dB	Confidence levels of 95%
Temperature	±0.7°C	Confidence levels of 95%
Humidity	±3.2%	Confidence levels of 95%
DC / AC Power Source	±1.4%	Confidence levels of 95%

3. GENERAL INFORMATION

3.1. Product Details

IEEE 802.11n

Items	Description
Product Type	WLAN (2TX, 2RX)
Radio Type	Intentional Transceiver
Power Type	From power adapter
Modulation	see the below table for IEEE 802.11n
Data Modulation	OFDM (BPSK / QPSK / 16QAM / 64QAM)
Data Rate (Mbps)	see the below table for IEEE 802.11n
Frequency Range	5150 ~ 5250MHz
Channel Number	4 for 20MHz bandwidth ; 2 for 40MHz bandwidth
Channel Band Width (99%)	MCS0 (20MHz): 17.12 MHz ; MCS0 (40MHz): 36.48 MHz
Conducted Output Power	MCS0 (20MHz): 16.77 dBm ; MCS0 (40MHz): 16.75 dBm
Carrier Frequencies	Please refer to section 3.4
Antenna	Please refer to section 3.3

IEEE 802.11a

Items	Description
Product Type	WLAN (2TX, 2RX)
Radio Type	Intentional Transceiver
Power Type	From power adapter
Modulation	OFDM for IEEE 802.11a
Data Modulation	OFDM (BPSK / QPSK / 16QAM / 64QAM)
Data Rate (Mbps)	OFDM (6/9/12/18/24/36/48/54)
Frequency Range	5150 ~ 5250MHz
Channel Number	4
Channel Band Width (99%)	15.84 MHz
Conducted Output Power	16.60 dBm
Carrier Frequencies	Please refer to section 3.4
Antenna	Please refer to section 3.3

Antenna & Band width

Antenna	Single (TX)		Two (TX)	
	20 MHz	40 MHz	20 MHz	40 MHz
IEEE 802.11a	X	X	V	X
IEEE 802.11n	X	X	V	V

IEEE 802.11n spec

MCS Index	Nss	Modulation	R	NBPS	NCBPS		NDBPS		Datarate(Mbps)			
					20MHz	40MHz	20MHz	40MHz	800nsGI		400nsGI	
									20MHz	40MHz	20MHz	40MHz
0	1	BPSK	1/2	1	52	108	26	54	6.5	13.5	7.200	15
1	1	QPSK	1/2	2	104	216	52	108	13.0	27.0	14.400	30
2	1	QPSK	3/4	2	104	216	78	162	19.5	40.5	21.700	45
3	1	16-QAM	1/2	4	208	432	104	216	26.0	54.0	28.900	60
4	1	16-QAM	3/4	4	208	432	156	324	39.0	81.0	43.300	90
5	1	64-QAM	2/3	6	312	648	208	432	52.0	108.0	57.800	120
6	1	64-QAM	3/4	6	312	648	234	486	58.5	121.5	65.000	135
7	1	64-QAM	5/6	6	312	648	260	540	65.0	135.0	72.200	150
8	2	BPSK	1/2	1	104	216	52	108	13.0	27.0	14.444	30
9	2	QPSK	1/2	2	208	432	104	216	26.0	54.0	28.889	60
10	2	QPSK	3/4	2	208	432	156	324	39.0	81.0	43.333	90
11	2	16-QAM	1/2	4	416	864	208	432	52.0	108.0	57.778	120
12	2	16-QAM	3/4	4	416	864	312	648	78.0	162.0	86.667	180
13	2	64-QAM	2/3	6	624	1296	416	864	104.0	216.0	115.556	240
14	2	64-QAM	3/4	6	624	1296	468	972	117.0	243.0	130.000	270
15	2	64-QAM	5/6	6	624	1296	520	1080	130.0	270.0	144.444	300

Symbol	Explanation
NSS	Number of spatial streams
R	Code rate
NBPS	Number of coded bits per single carrier
NCBPS	Number of coded bits per symbol
NDBPS	Number of data bits per symbol
GI	guard interval

3.2. Accessories

Power	Brand	Model	P/N	Rating
Adapter 1	NETGEAR	MT12-N120100-A1	332-10252-01	Input: 120VAC, 60Hz, 0.5A Output: 12VDC, 1A
Adapter 2	NETGEAR	AD810F10	332-10329-01	Input: 100-120VAC, 50/60Hz, 0.3A Output: 12VDC, 1A
Others				
Foot Holder				

3.3. Table for Filed Antenna

Ant.	Brand	Model Name	Antenna Type	Connector	Gain (dBi)	
					2.4GHz	5GHz
1	-	-	PCB Antenna	I-PEX	2.84	2.67
					2.44	2.96
2	Foxconn	FX01B86-0G-EF	PCB Antenna	I-PEX	2.59	
3	-	-	PIFA Antenna	I-PEX	2.44	2.96
					2.80	
4	Foxconn	FX01B82-0G-EF	PCB Antenna	I-PEX	2.80	

Note: The EUT has four antennas.

Both Ant. 1 and Ant. 3 can be used as transmitting/receiving antennas.

Ant. 1 and Ant. 3 could transmit/receive simultaneously.

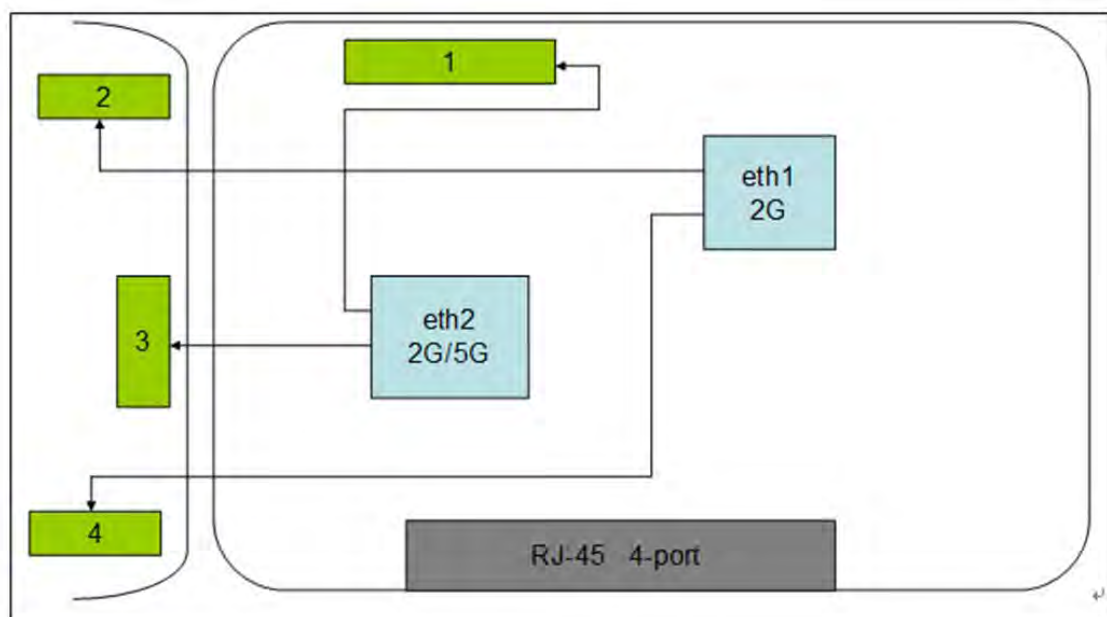

3.4. Table for Carrier Frequencies

For IEEE 802.11a, use Channel 36, 40, 44, 48.

There are two bandwidth systems for IEEE 802.11n.

For both 20MHz bandwidth systems, use Channel 36, 40, 44, 48.

For both 40MHz bandwidth systems, use Channel 38, 46.

Frequency Band	Channel No.	Frequency	Channel No.	Frequency
5150~5250 MHz Band 1	36	5180 MHz	44	5220 MHz
	38	5190 MHz	46	5230 MHz
	40	5200 MHz	48	5240 MHz

3.5. Table for Test Modes

Preliminary tests were performed in different data rate to find the worst radiated emission. The data rate shown in the table below is the worst-case rate with respect to the specific test item. Investigation has been done on all the possible configurations for searching the worst cases. The following table is a list of the test modes shown in this test report.

Test Items	Mode		Data Rate	Channel	Antenna
AC Power Conducted Emission	Normal Link		Auto	-	-
Max. Conducted Output Power Power Spectral Density	MCS0/20MHz	Band 1	7.2Mbps	36/40/48	1/3/1+3
	MCS0/40MHz	Band 1	14.4Mbps	38/46	1/3/1+3
	11a/BPSK	Band 1	6Mbps	36/40/48	1/3/1+3
26dB Spectrum Bandwidth 99% Occupied Bandwidth Measurement Peak Excursion	MCS0/20MHz	Band 1	7.2Mbps	36/40/48	1+3
	MCS0/40MHz	Band 1	14.4Mbps	38/46	1+3
	11a/BPSK	Band 1	6Mbps	36/40/48	1+3
Radiated Emission Below 1GHz	Normal Link		Auto	-	-
Radiated Emission Above 1GHz	MCS0/20MHz	Band 1	7.2Mbps	36/40/48	1+3
	MCS0/40MHz	Band 1	14.4Mbps	38/46	1+3
	11a/BPSK	Band 1	6Mbps	36/40/48	1+3
Band Edge Emission	MCS0/20MHz	Band 1	7.2Mbps	36/40/48	1+3
	MCS0/40MHz	Band 1	14.4Mbps	38/46	1+3
	11a/BPSK	Band 1	6Mbps	36/40/48	1+3
Frequency Stability	Un-modulation		-	40	N/A

The following test modes were performed for all tests:

Mode 1. EUT + Adapter 1

Mode 2. EUT + Adapter 2

For Conducted Emission test:

Due to Mode 1 generated the worst test result, so it was recorded in this report.

For Radiated Emission test:

Due to Mode 2 generated the worst test result, so it was recorded in this report.

For MPE and Co-location Test:

The EUT could be applied with 2.4GHz WLAN function and 5GHz WLAN function; therefore Maximum Permissible Exposure (Please refer to Appendix B) and Co-location (please refer to Appendix C) tests are added for simultaneously transmit between 2.4GHz WLAN function and 5GHz WLAN function.

3.6. Table for Testing Locations

Test Site No.	Site Category	Location	FCC Reg. No.	IC File No.	VCCI Reg. No
03CH01-CB	SAC	Hsin Chu	262045	IC 4086D	-
CO01-CB	Conduction	Hsin Chu	262045	IC 4086D	-
TH01-CB	OVEN Room	Hsin Chu	-	-	-

Open Area Test Site (OATS); Semi Anechoic Chamber (SAC); Fully Anechoic Chamber (FAC).

Please refer section 6 for Test Site Address.

3.7. Table for Supporting Units

Support Unit	Brand	Model	FCC ID
Notebook	DELL	D400	QDS-BRCM1005-D
Notebook	DELL	D400	QDS-BRCM1005-D
Notebook	DELL	D420	E2KWM3945ABG
Notebook	DELL	1200	E2K4965AGNM

3.8. Table for Parameters of Test Software Setting

During testing, Channel & Power Controlling Software provided by the customer was used to control the operating channel as well as the output power level. The RF output power selection is for the setting of RF output power expected by the customer and is going to be fixed on the firmware of the final end product.

Power Parameters of IEEE 802.11n MCS0 20MHz

Test Software Version	DOS		
Frequency	5180 MHz	5200 MHz	5240 MHz
MCS0 20MHz	52	50	50

Power Parameters of IEEE 802.11n MCS0 40MHz

Test Software Version	DOS	
Frequency	5190 MHz	5230 MHz
MCS0 40MHz	42	50

Power Parameters of IEEE 802.11a

Test Software Version	DOS		
Frequency	5180 MHz	5200 MHz	5240 MHz
802.11a	50	50	50

During the test, "DOS" under WIN XP was executed the test program to control the EUT continuously transmit RF signal.

3.9. Test Configurations

3.9.1. Radiation Emissions Test Configuration

Test Mode: Mode 2

Test Configuration: 30MHz ~ 1GHz

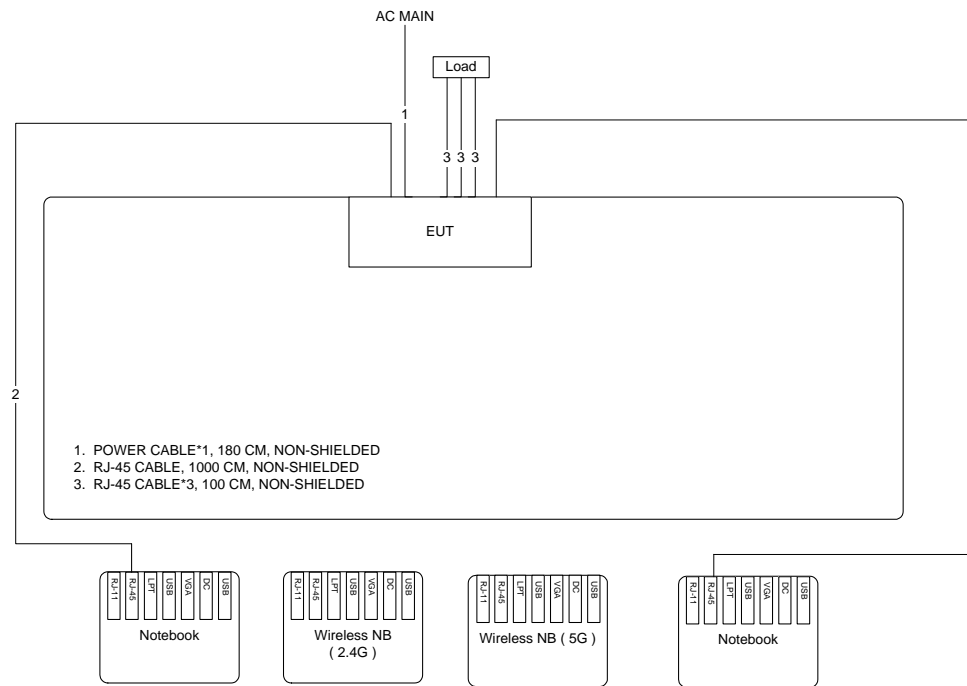

Test Configuration: above 1GHz

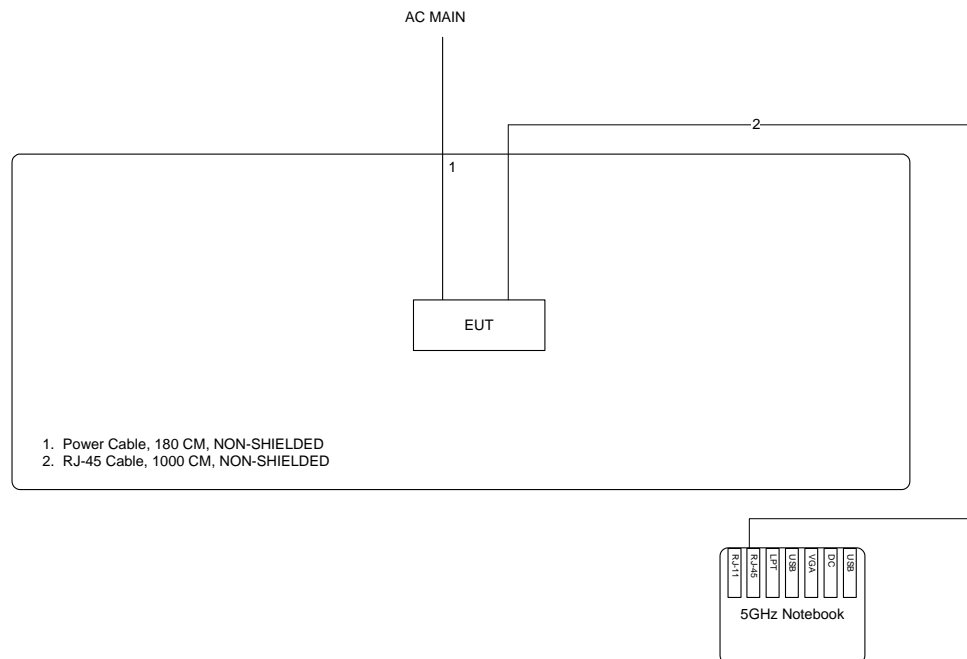

3.9.2. AC Power Line Conduction Emissions Test Configuration

Test Mode: Mode 1

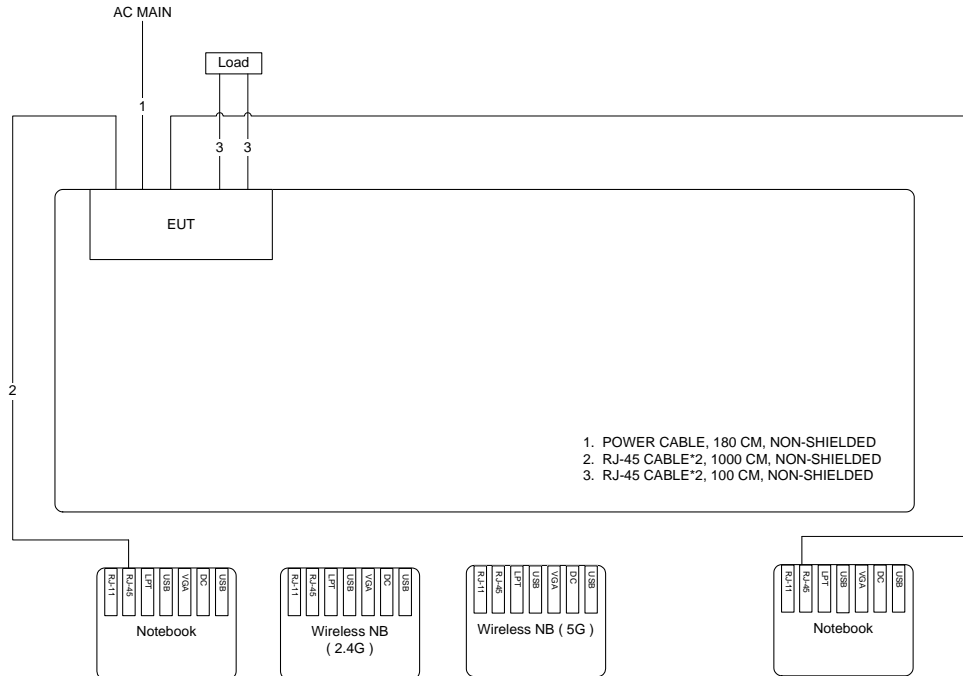

4. TEST RESULT

4.1. AC Power Line Conducted Emissions Measurement

4.1.1. Limit

For this product that is designed to connect to the AC power line, the radio frequency voltage that is conducted back onto the AC power line on any frequency or frequencies within the band 150 kHz to 30 MHz shall not exceed below limits table.

Frequency (MHz)	QP Limit (dBuV)	AV Limit (dBuV)
0.15~0.5	66~56	56~46
0.5~5	56	46
5~30	60	50

4.1.2. Measuring Instruments and Setting

Please refer to section 5 of equipments list in this report. The following table is the setting of the receiver.

Receiver Parameters	Setting
Attenuation	10 dB
Start Frequency	0.15 MHz
Stop Frequency	30 MHz
IF Bandwidth	9 KHz

4.1.3. Test Procedures

1. Configure the EUT according to ANSI C63.10. The EUT or host of EUT has to be placed 0.4 meter far from the conducting wall of the shielding room and at least 80 centimeters from any other grounded conducting surface.
2. Connect EUT or host of EUT to the power mains through a line impedance stabilization network (LISN).
3. All the support units are connected to the other LISNs. The LISN should provide 50uH/50ohms coupling impedance.
4. The frequency range from 150 KHz to 30 MHz was searched.
5. Set the test-receiver system to Peak Detect Function and Specified Bandwidth with Maximum Hold Mode.
6. The measurement has to be done between each power line and ground at the power terminal.

4.1.4. Test Setup Layout

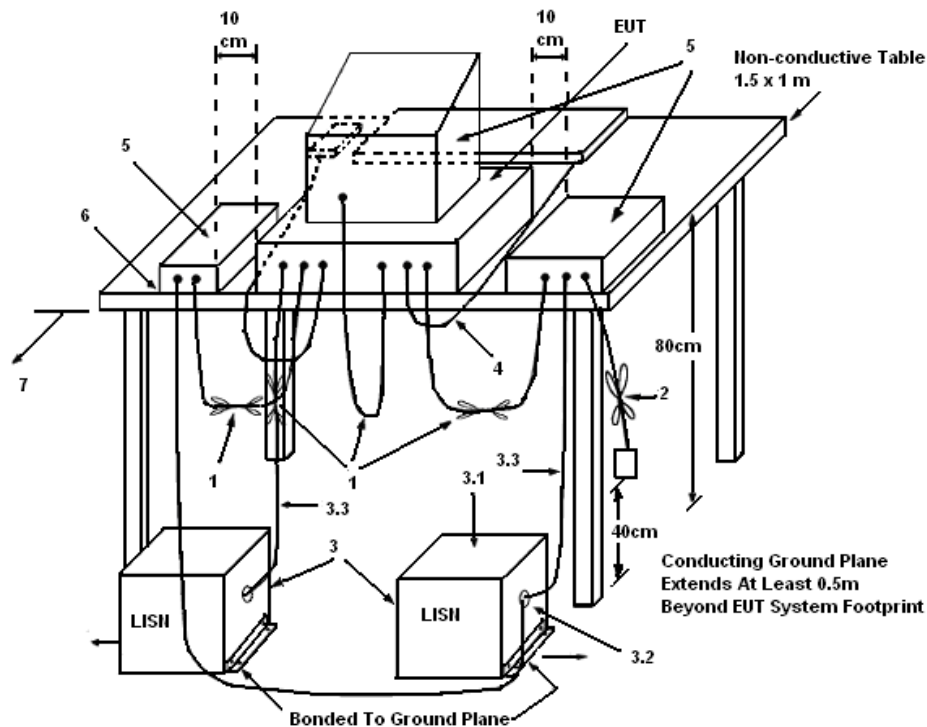

LEGEND:

- (1) Interconnecting cables that hang closer than 40 cm to the ground plane shall be folded back and forth in the center forming a bundle 30 to 40 cm long.
- (2) I/O cables that are not connected to a peripheral shall be bundled in the center. The end of the cable may be terminated, if required, using the correct terminating impedance. The overall length shall not exceed 1 m.
- (3) EUT connected to one LISN. Unused LISN measuring port connectors shall be terminated in 50 Ω . LISN can be placed on top of, or immediately beneath, reference ground plane.
 - (3.1) All other equipment powered from additional LISN(s).
 - (3.2) Multiple outlet strip can be used for multiple power cords of non-EUT equipment.
 - (3.3) LISN at least 80 cm from nearest part of EUT chassis.
- (4) Cables of hand-operated devices, such as keyboards, mice, etc., shall be placed as for normal use.
- (5) Non-EUT components of EUT system being tested.
- (6) Rear of EUT, including peripherals, shall all be aligned and flush with rear of tabletop.
- (7) Rear of tabletop shall be 40 cm removed from a vertical conducting plane that is bonded to the ground plane.

4.1.5. Test Deviation

There is no deviation with the original standard.

4.1.6. EUT Operation during Test

The EUT was placed on the test table and programmed in normal function.

4.1.7. Results of AC Power Line Conducted Emissions Measurement

Temperature	21°C	Humidity	61%
Test Engineer	Simon Yang	Phase	Line
Configuration	Normal Link	Test Mode	Mode 1

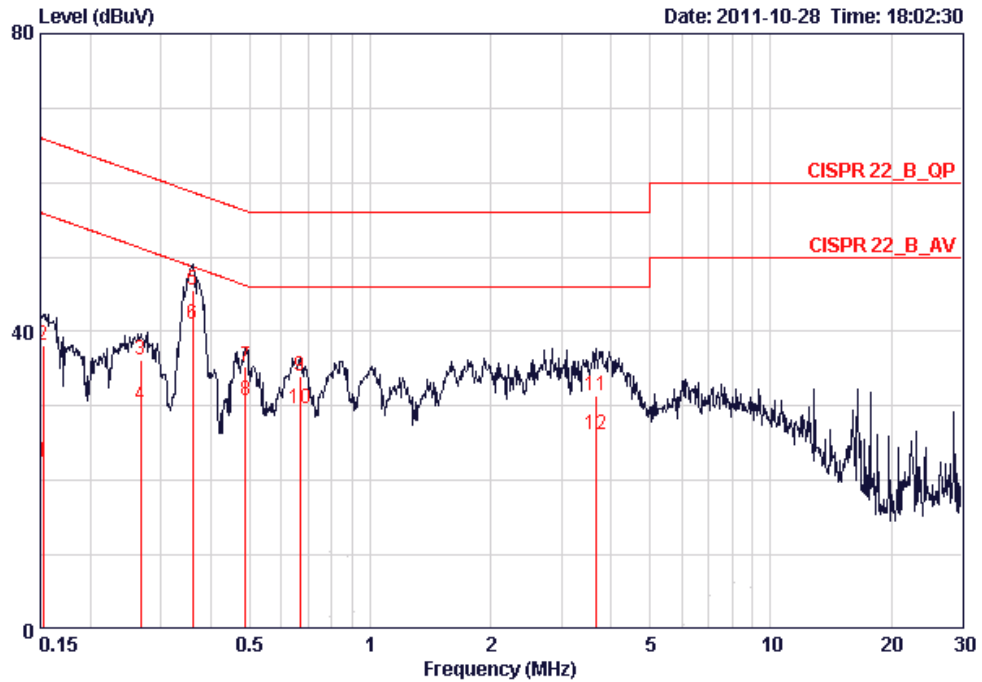

	Freq	Level	Over	Limit	Read	LISN	Cable	Remark
	MHz	dBuV	Limit	Line	Level	Factor	Loss	
			dB	dBuV	dBuV	dB	dB	
1	0.15240	22.53	-33.33	55.87	22.26	0.07	0.20	AVERAGE
2	0.15240	38.04	-27.82	65.87	37.77	0.07	0.20	QP
3	0.26724	36.17	-25.03	61.20	35.93	0.04	0.20	QP
4	0.26724	30.07	-21.13	51.20	29.83	0.04	0.20	AVERAGE
5	0.35955	45.59	-13.15	58.74	45.36	0.03	0.20	QP
6	0.35955	40.89	-7.85	48.74	40.66	0.03	0.20	AVERAGE
7	0.48890	35.36	-20.82	56.19	35.22	0.03	0.11	QP
8	0.48890	30.83	-15.35	46.19	30.69	0.03	0.11	AVERAGE
9	0.66832	34.06	-21.94	56.00	33.83	0.03	0.20	QP
10	0.66832	29.73	-16.27	46.00	29.50	0.03	0.20	AVERAGE
11	3.661	31.49	-24.51	56.00	31.10	0.09	0.30	QP
12	3.661	26.20	-19.80	46.00	25.81	0.09	0.30	AVERAGE

Temperature	21°C	Humidity	61%
Test Engineer	Simon Yang	Phase	Neutral
Configuration	Normal Link	Test Mode	Mode 1

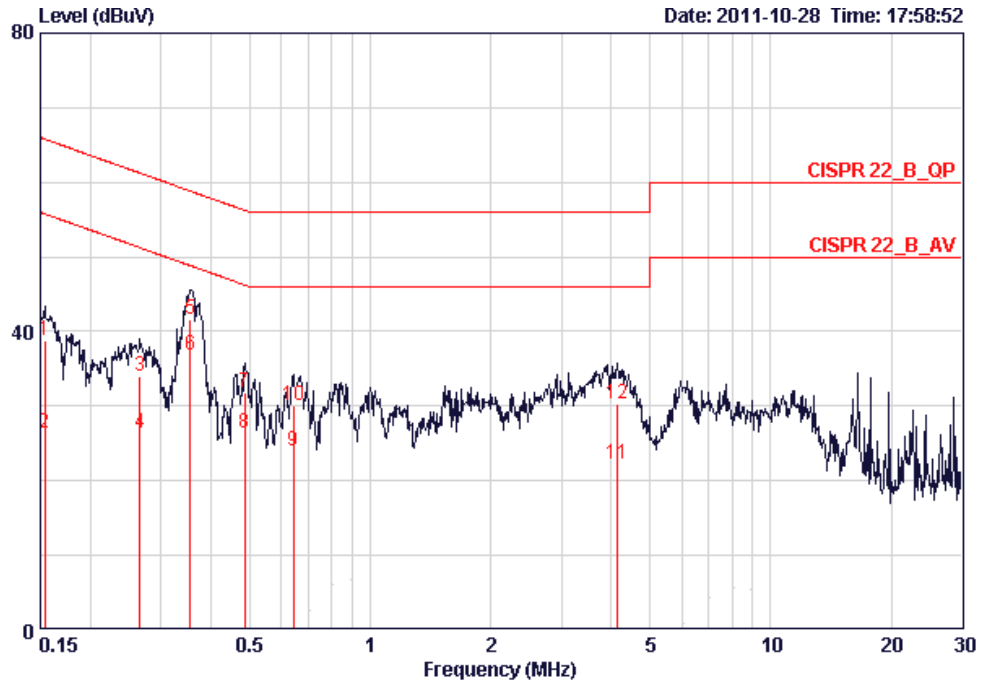

	Freq	Level	Over Limit	Limit Line	Read Level	LISN Factor	Cable Loss	Remark
	MHz	dBuV	dB	dBuV	dBuV	dB	dB	
1	0.15403	38.85	-26.93	65.78	38.55	0.10	0.20	QP
2	0.15403	26.27	-29.51	55.78	25.97	0.10	0.20	AVERAGE
3	0.26583	33.97	-27.28	61.25	33.69	0.08	0.20	QP
4	0.26583	26.39	-24.86	51.25	26.11	0.08	0.20	AVERAGE
5	0.35576	41.53	-17.30	58.83	41.26	0.07	0.20	QP
6 B	0.35576	36.87	-11.96	48.83	36.60	0.07	0.20	AVERAGE
7	0.48632	31.91	-24.32	56.23	31.73	0.07	0.11	QP
8	0.48632	26.30	-19.93	46.23	26.12	0.07	0.11	AVERAGE
9	0.64398	23.89	-22.11	46.00	23.62	0.07	0.20	AVERAGE
10	0.64398	30.07	-25.93	56.00	29.80	0.07	0.20	QP
11	4.136	22.16	-23.84	46.00	21.71	0.15	0.30	AVERAGE
12	4.136	30.33	-25.67	56.00	29.88	0.15	0.30	QP

Note:

Level = Read Level + LISN Factor + Cable Loss.

4.2. 99% Occupied Bandwidth Measurement

4.2.1. Limit

No restriction limits. But resolution bandwidth within band edge measurement is 1% of the 99% occupied bandwidth.

4.2.2. Measuring Instruments and Setting

Please refer to section 5 of equipments list in this report. The following table is the setting of the spectrum analyzer.

Spectrum Parameters	Setting
Attenuation	Auto
Span Frequency	> 26dB Bandwidth
RB	300 kHz
VB	1000 kHz
Detector	Peak
Trace	Max Hold
Sweep Time	Auto

4.2.3. Test Procedures

1. The transmitter output (antenna port) was connected to the spectrum analyzer in peak hold mode.
2. The resolution bandwidth of 300 kHz and the video bandwidth of 1000 kHz were used.
3. Measured the spectrum width with power higher than 26dB below carrier.

4.2.4. Test Setup Layout

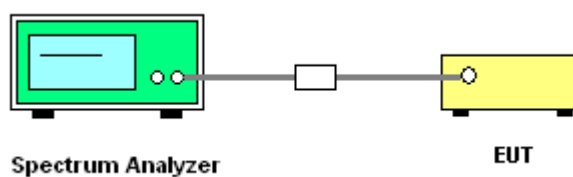

4.2.5. Test Deviation

There is no deviation with the original standard.

4.2.6. EUT Operation during Test

The EUT was programmed to be in continuously transmitting mode.

4.2.7. Test Result of 99% Occupied Bandwidth

Temperature	25°C	Humidity	60%
Test Engineer	Sean Ku	Configurations	IEEE 802.11n

Configuration IEEE 802.11n MCS0 20MHz / Ant. 1 + Ant. 3

Channel	Frequency	26dB Bandwidth (MHz)	99% Occupied Bandwidth (MHz)
36	5180 MHz	19.52	17.12
40	5200 MHz	19.36	16.96
48	5240 MHz	19.52	17.12

Configuration IEEE 802.11n MCS0 40MHz / Ant. 1 + Ant. 3

Channel	Frequency	26dB Bandwidth (MHz)	99% Occupied Bandwidth (MHz)
38	5190 MHz	39.04	36.48
46	5230 MHz	39.04	36.48

Temperature	25°C	Humidity	60%
Test Engineer	Sean Ku	Configurations	IEEE 802.11a

Configuration IEEE 802.11a / Ant. 1 + Ant. 3

Channel	Frequency	26dB Bandwidth (MHz)	99% Occupied Bandwidth (MHz)
36	5180 MHz	18.88	15.68
40	5200 MHz	18.72	15.84
48	5240 MHz	18.88	15.84

26 dB Bandwidth Plot on Configuration IEEE 802.11n MCS0 20MHz / Ant. 1 + Ant. 3 / 5180 MHz

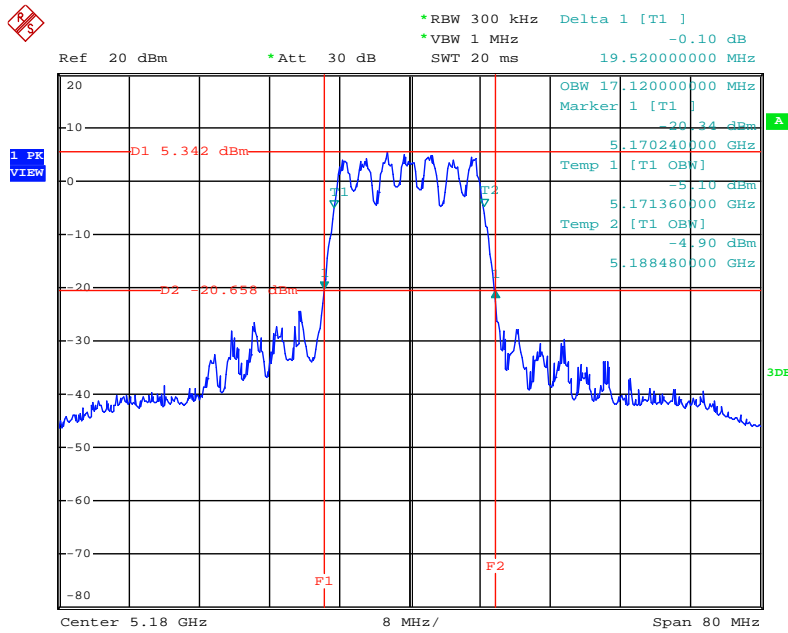

Date: 3.NOV.2011 02:05:53

26 dB Bandwidth Plot on Configuration IEEE 802.11n MCS0 20MHz / Ant. 1 + Ant. 3 / 5200 MHz

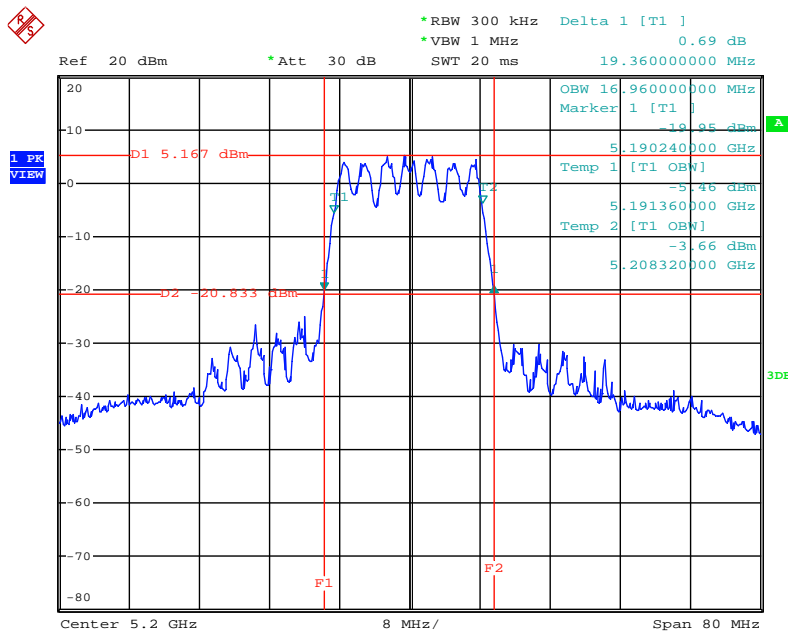

Date: 3.NOV.2011 02:06:45

26 dB Bandwidth Plot on Configuration IEEE 802.11n MCS0 20MHz / Ant. 1 + Ant. 3 / 5240 MHz

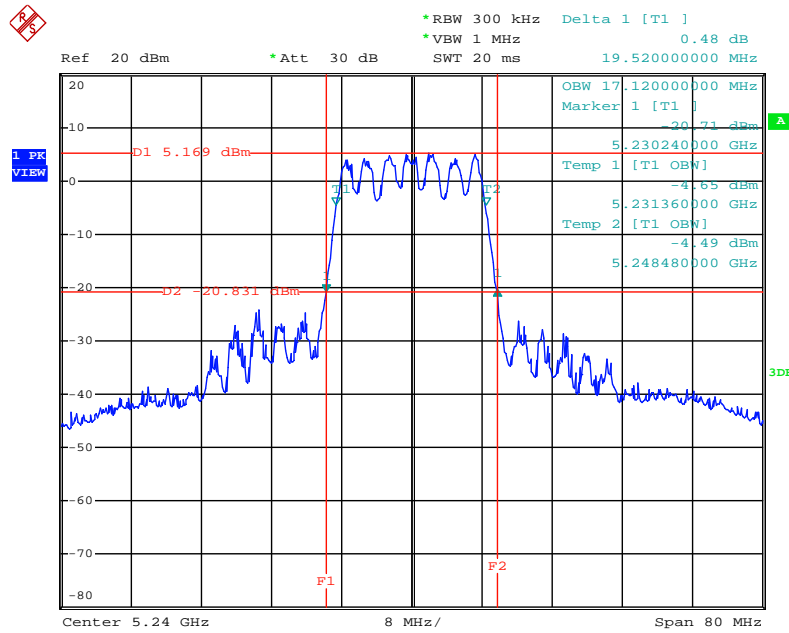

Date: 3.NOV.2011 02:08:04

26 dB Bandwidth Plot on Configuration IEEE 802.11n MCS0 40MHz / Ant. 1 + Ant. 3 / 5190 MHz

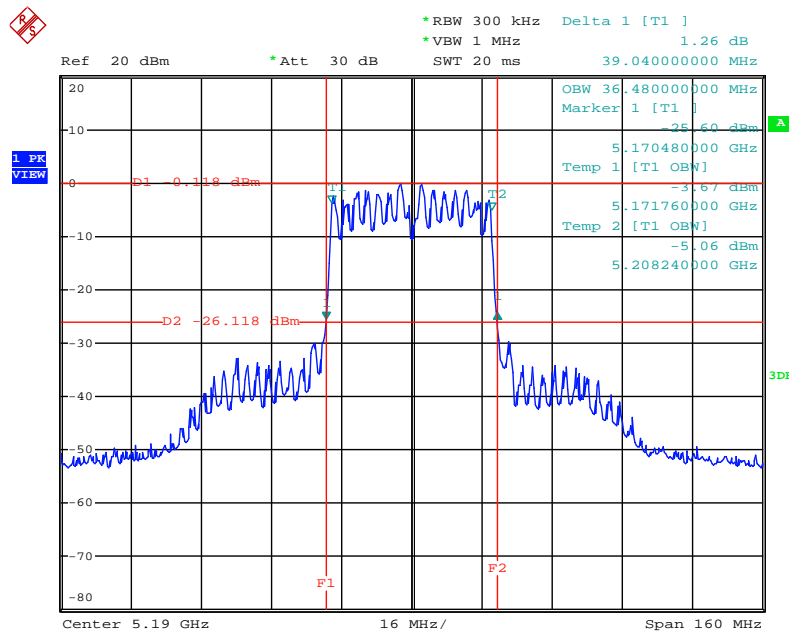

Date: 3.NOV.2011 02:19:13

26 dB Bandwidth Plot on Configuration IEEE 802.11n MCS0 40MHz / Ant. 1 + Ant. 3 / 5230 MHz

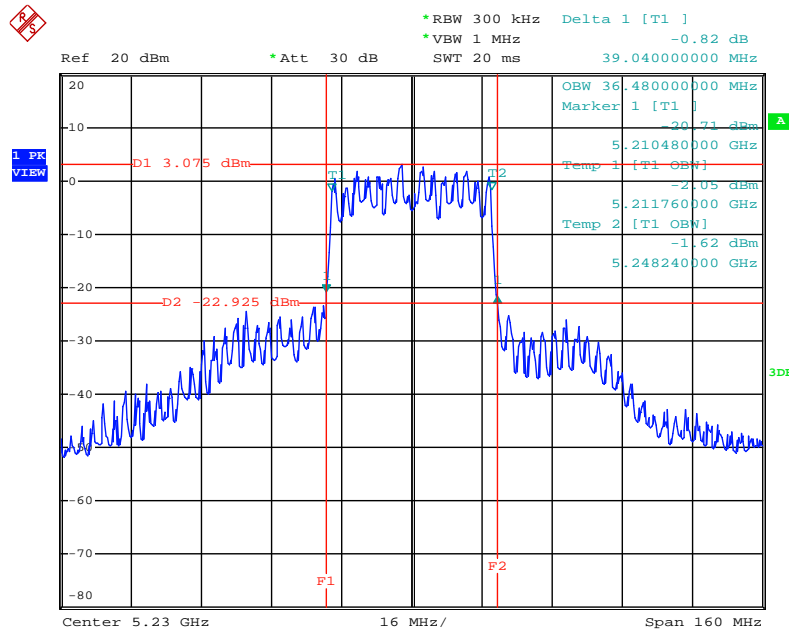

Date: 3.NOV.2011 02:20:12

26 dB Bandwidth Plot on Configuration IEEE 802.11a / Ant. 1 + Ant. 3 / 5180 MHz

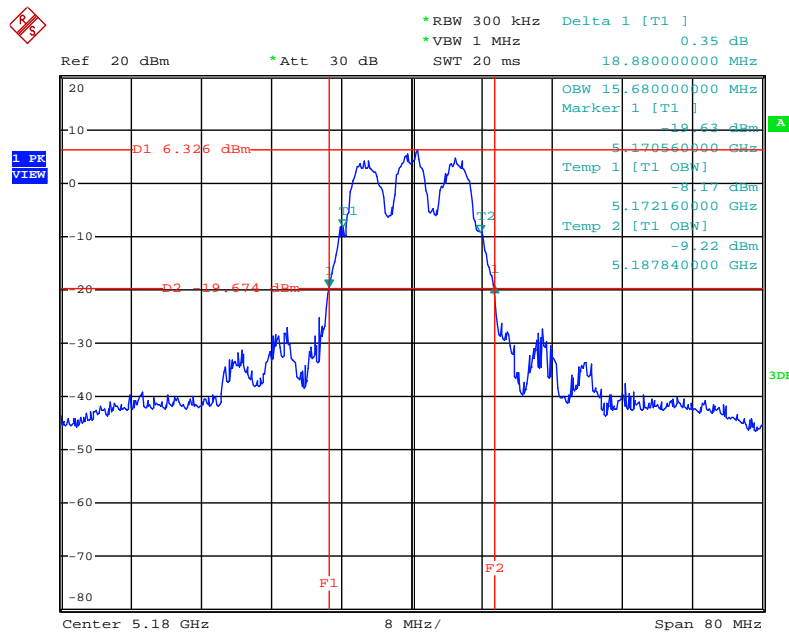

Date: 3.NOV.2011 01:11:43

26 dB Bandwidth Plot on Configuration IEEE 802.11a / Ant. 1 + Ant. 3 / 5200 MHz

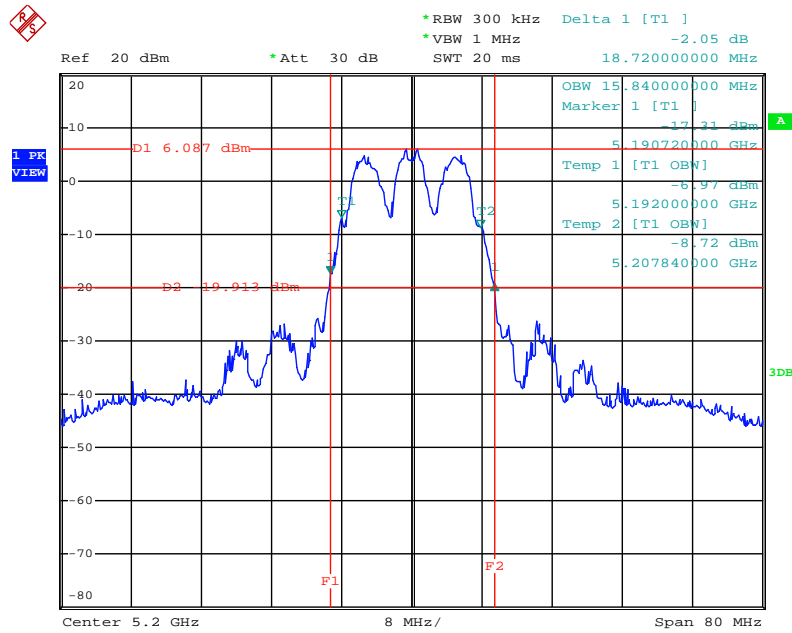

Date: 3.NOV.2011 01:13:10

26 dB Bandwidth Plot on Configuration IEEE 802.11a / Ant. 1 + Ant. 3 / 5240 MHz

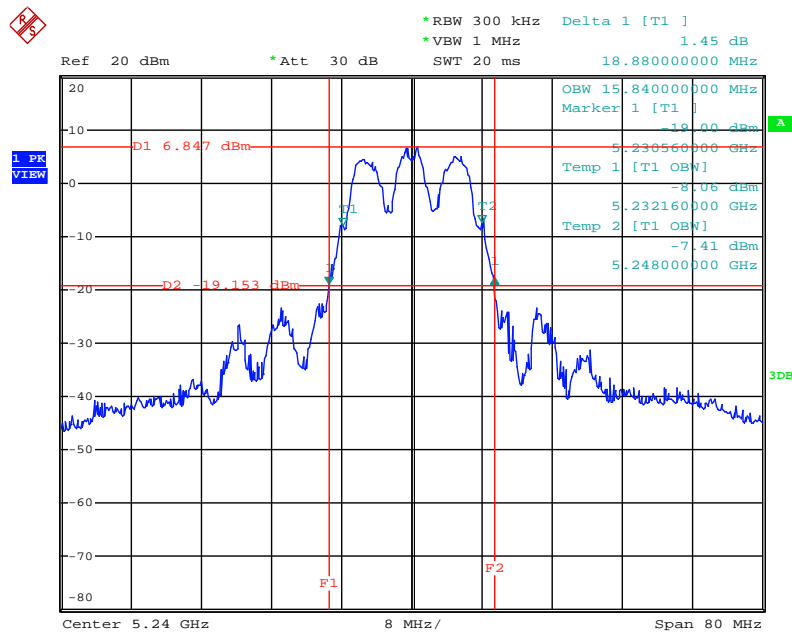

Date: 3.NOV.2011 01:15:14

4.3. Maximum Conducted Output Power Measurement

4.3.1. Limit

For the band 5.15~5.25 GHz, the maximum conducted output power over the frequency band of operation shall not exceed the lesser of 50 mW (17dBm) or $4 \text{ dBm} + 10\log B$, where B is the 26 dB emissions bandwidth in MHz. If transmitting antennas of directional gain greater than 6 dBi are used, both the maximum conducted output power and the peak power spectral density shall be reduced by the amount in dB that the directional gain of the antenna exceeds 6 dBi.

4.3.2. Measuring Instruments and Setting

The following table is the setting of the peak power meter.

Power Meter Parameter	Setting
Bandwidth	50MHz bandwidth is greater than the EUT emission bandwidth
Detector	AVERAGE

4.3.3. Test Procedures

Spectrum Parameter	Setting
RF Output Power Method	<input checked="" type="checkbox"/> ANSI C63.10 clause 6.10.2.1 (a) power meter method
RF Output Power Method	<input type="checkbox"/> ANSI C63.10 clause 6.10.2.1 (b) channel integration method
RF Output Power Method	<input type="checkbox"/> ANSI C63.10 clause 6.10.3.1 Method 1 - spectral trace averaging
RF Output Power Method	<input type="checkbox"/> ANSI C63.10 clause 6.10.3.2 Method 2 - zero-span mode with trace averaging

4.3.4. Test Setup Layout

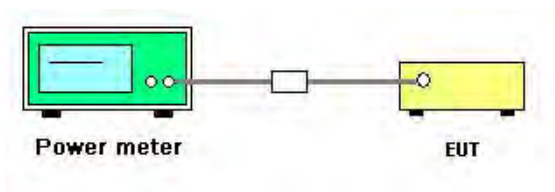

4.3.5. Test Deviation

There is no deviation with the original standard.

4.3.6. EUT Operation during Test

The EUT was programmed to be in continuously transmitting mode.

4.3.7. Test Result of Maximum Conducted Output Power

Temperature	25°C	Humidity	60%
Test Engineer	Sean Ku	Configurations	IEEE 802.11n
Test Date	Nov. 02, 2011		

Configuration IEEE 802.11n MCS0 20MHz

Channel	Frequency	Conducted Power (dBm)		Total Conducted Output Power (dBm)	Max. Limit (dBm)	Result
		Ant. 1	Ant. 3			
36	5180 MHz	13.52	13.85	16.70	16.90	Complies
40	5200 MHz	13.47	13.88	16.69	16.87	Complies
48	5240 MHz	14.06	13.43	16.77	16.90	Complies

Configuration IEEE 802.11n MCS0 40MHz / Ant. 1

Channel	Frequency	Conducted Power (dBm)		Total Conducted Output Power (dBm)	Max. Limit (dBm)	Result
		Ant. 1	Ant. 3			
38	5190 MHz	11.74	12.00	14.88	17.00	Complies
46	5230 MHz	13.81	13.66	16.75	17.00	Complies

Temperature	25°C	Humidity	60%
Test Engineer	Sean Ku	Configurations	IEEE 802.11a
Test Date	Nov. 02, 2011		

Configuration IEEE 802.11a

Channel	Frequency	Conducted Power (dBm)		Total Conducted Output Power (dBm)	Max. Limit (dBm)	Result
		Ant. 1	Ant. 3			
36	5180 MHz	13.85	13.32	16.60	16.76	Complies
40	5200 MHz	13.86	13.04	16.48	16.72	Complies
48	5240 MHz	13.48	13.12	16.31	16.76	Complies

4.4. Power Spectral Density Measurement

4.4.1. Limit

The power spectral density is defined as the highest level of power in dBm per MHz generated by the transmitter within the power envelope. The following table is power spectral density limits and decrease power density limit rule refer to section 4.3.1.

Frequency Range	Power Spectral Density limit (dBm/MHz)
5.15~5.25 GHz	4

4.4.2. Measuring Instruments and Setting

Please refer to section 5 of equipments list in this report. The following table is the setting of the spectrum analyzer.

Spectrum Parameter	Setting
Attenuation	Auto
Span Frequency	Encompass the entire emissions bandwidth (EBW) of the signal
RB	1000 kHz
VB	3000 kHz
Detector	RMS
Trace	AVERAGE
Sweep Time	Auto
Trace Average	100 times

4.4.3. Test Procedures

1. The test procedure is the same as section 4.6.3.
2. Trace A, Set RBW = 1MHz, VBW = 3MHz, Span >26dB bandwidth, Max. hold.
3. Delta Mark trace A Maximum frequency and trace B same frequency.
4. Repeat the above procedure until measurements for all frequencies were complete.

4.4.4. Test Setup Layout

This test setup layout is the same as that shown in section 4.6.4.

4.4.5. Test Deviation

There is no deviation with the original standard.

4.4.6. EUT Operation during Test

The EUT was programmed to be in continuously transmitting mode.

4.4.7. Test Result of Power Spectral Density

Temperature	25°C	Humidity	60%
Test Engineer	Sean Ku	Configurations	IEEE 802.11n

Configuration IEEE 802.11n MCS0 20MHz

Channel	Frequency	Power Density (dBm/3kHz)		Total Power Density (dBm/3kHz)	Max. Limit (dBm/3kHz)	Result
		Ant. 1	Ant. 3			
36	5180 MHz	-0.04	-0.01	2.99	4.00	Complies
40	5200 MHz	-0.01	-0.31	2.85	4.00	Complies
48	5240 MHz	0.78	0.37	3.59	4.00	Complies

Configuration IEEE 802.11n MCS0 40MHz

Channel	Frequency	Power Density (dBm/3kHz)		Total Power Density (dBm/3kHz)	Max. Limit (dBm/3kHz)	Result
		Ant. 1	Ant. 3			
38	5190 MHz	-5.73	-6.30	-3.00	4.00	Complies
46	5230 MHz	-2.97	-3.41	-0.17	4.00	Complies

Note: All the test values were listed in the report.

For plots, only the channel with maximum results was shown.

Temperature	25°C	Humidity	60%
Test Engineer	Sean Ku	Configurations	IEEE 802.11a

Configuration IEEE 802.11a

Channel	Frequency	Power Density (dBm/3kHz)		Total Power Density (dBm/3kHz)	Max. Limit (dBm/3kHz)	Result
		Ant. 1	Ant. 3			
36	5180 MHz	-0.35	-0.31	2.68	4.00	Complies
40	5200 MHz	0.26	0.10	3.19	4.00	Complies
48	5240 MHz	0.91	1.06	4.00	4.00	Complies

Note: All the test values were listed in the report.

For plots, only the channel with maximum results was shown.

Power Density Plot on Configuration IEEE 802.11n MCS0 20MHz / Ant. 1 / 5240 MHz

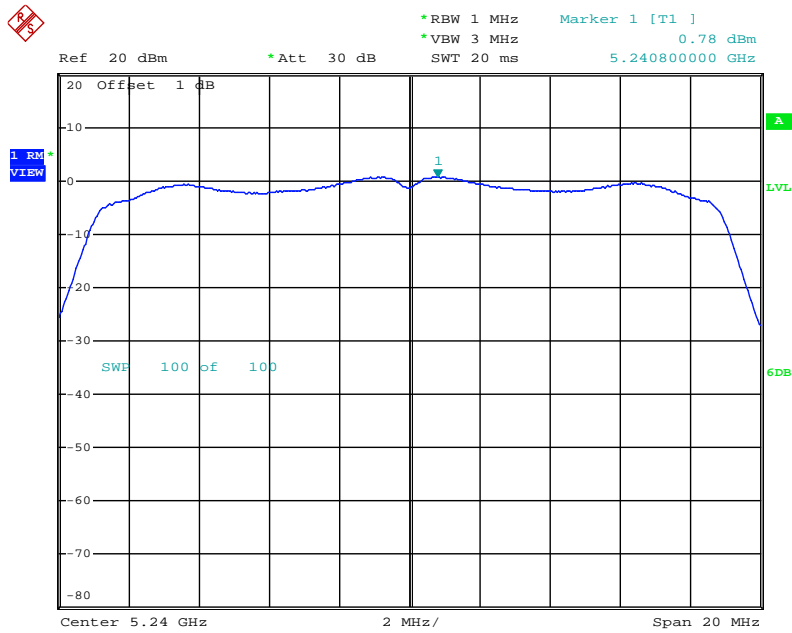

Date: 3.NOV.2011 11:39:49

Power Density Plot on Configuration IEEE 802.11n MCS0 20MHz / Ant. 3 / 5240 MHz

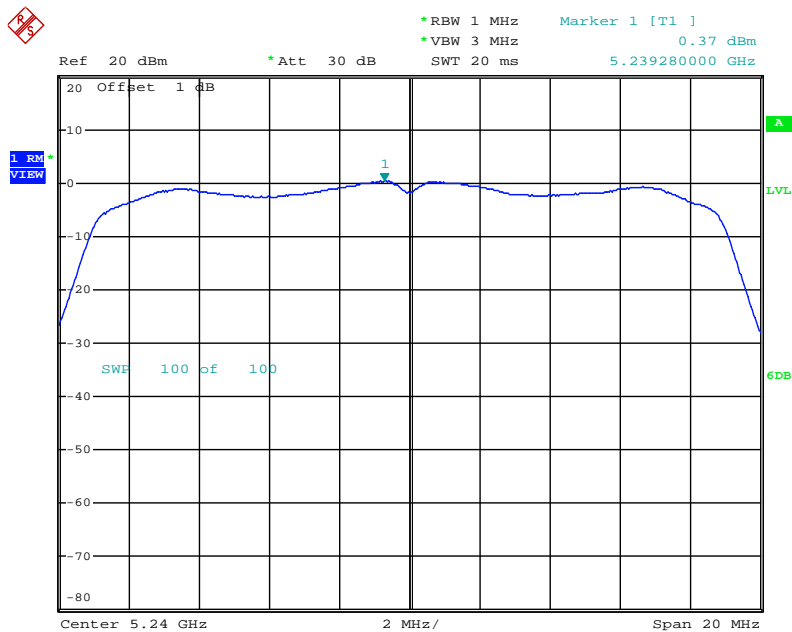

Date: 3.NOV.2011 11:39:30

Power Density Plot on Configuration IEEE 802.11n MCS0 40MHz / Ant. 1 / 5230 MHz

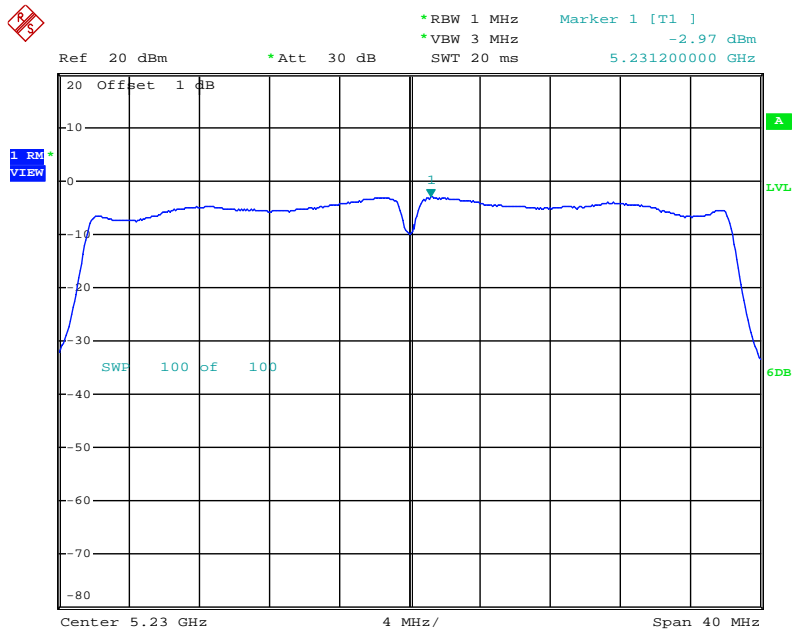

Date: 3.NOV.2011 12:06:39

Power Density Plot on Configuration IEEE 802.11n MCS0 40MHz / Ant. 3 / 5230 MHz

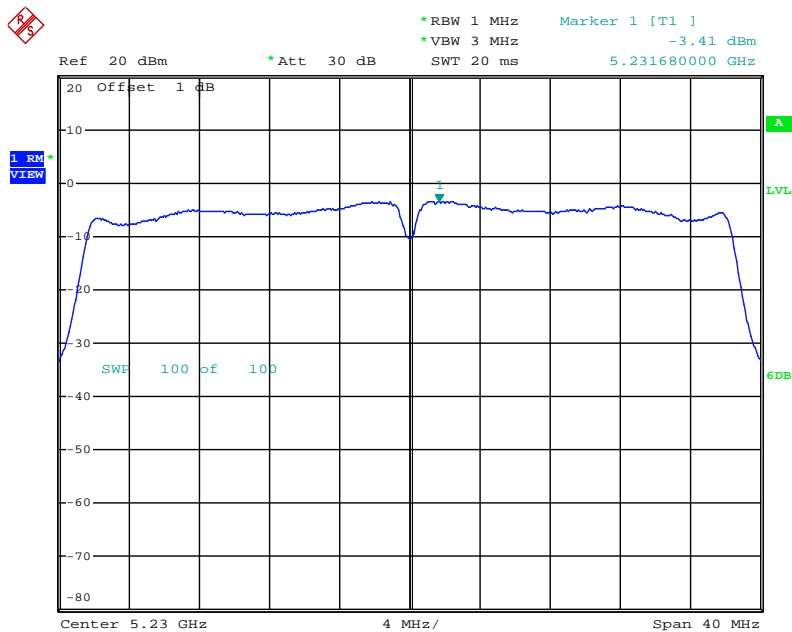

Date: 3.NOV.2011 12:06:14

Power Density Plot on Configuration IEEE 802.11a / Ant. 1 / 5240 MHz

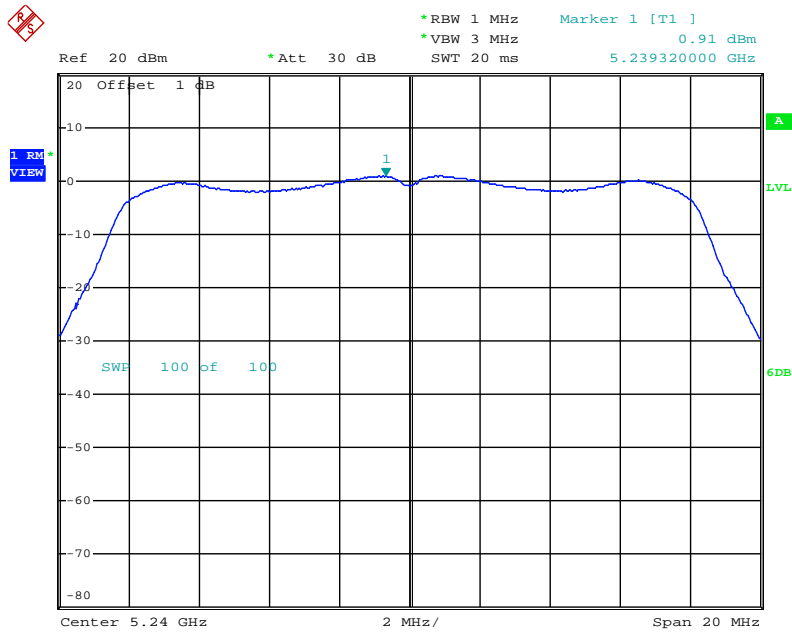

Date: 3.NOV.2011 10:59:51

Power Density Plot on Configuration IEEE 802.11a / Ant. 3 / 5240 MHz

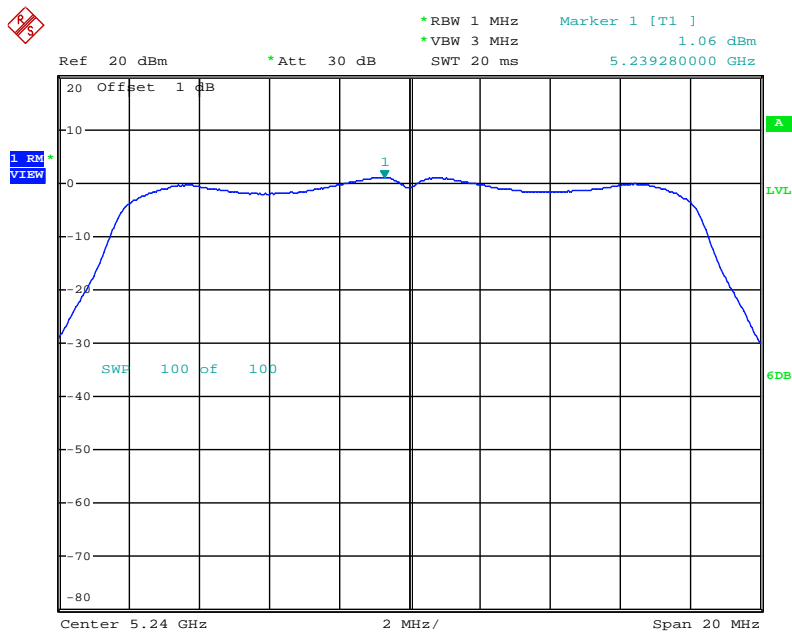

Date: 3.NOV.2011 10:58:41

4.5. Peak Excursion Measurement

4.5.1. Limit

The ratio of the peak excursion of the modulation envelope (measured using a peak hold function) to the maximum conducted output power (measured as specified above) shall not exceed 13 dB across any 1 MHz bandwidth or the emissions bandwidth whichever is less.

4.5.2. Measuring Instruments and Setting

Please refer to section 5 of equipments list in this report. The following table is the setting of the spectrum analyzer.

Spectrum Parameter	Setting
Attenuation	Auto
Span Frequency	Encompass the entire emissions bandwidth (EBW) of the signal
RB	1000 kHz (Peak Trace) / 1000 kHz (Average Trace)
VB	3000 kHz (Peak Trace) / 300 kHz (Average Trace)
Detector	Peak (Peak Trace) / Sample (Average Trace)
Trace	Max Hold
Sweep Time	60s

4.5.3. Test Procedures

1. The test procedure is the same as section 4.6.3.
2. Trace A, Set RBW = 1MHz, VBW = 3MHz, Span >26dB bandwidth, Max. hold.
3. Delta Mark trace A Maximum frequency and trace B same frequency.
4. Repeat the above procedure until measurements for all frequencies were complete.

4.5.4. Test Setup Layout

This test setup layout is the same as that shown in section 4.6.4.

4.5.5. Test Deviation

There is no deviation with the original standard.

4.5.6. EUT Operation during Test

The EUT was programmed to be in continuously transmitting mode.

4.5.7. Test Result of Peak Excursion

Temperature	25°C	Humidity	60%
Test Engineer	Sean Ku	Configurations	IEEE 802.11n

Configuration IEEE 802.11n MCS0 20MHz / Ant. 1 + Ant. 3

Channel	Frequency	Peak Excursion (dB)	Max. Limit (dB)	Result
36	5180 MHz	4.43	13	Complies
40	5200 MHz	4.38	13	Complies
48	5240 MHz	5.44	13	Complies

Configuration IEEE 802.11n MCS0 40MHz / Ant. 1 + Ant. 3

Channel	Frequency	Peak Excursion (dB)	Max. Limit (dB)	Result
38	5190 MHz	5.23	13	Complies
46	5230 MHz	4.50	13	Complies

Note: All the test values were listed in the report.

For plots, only the channel with maximum results was shown.

Temperature	25°C	Humidity	60%
Test Engineer	Sean Ku	Configurations	IEEE 802.11a

Configuration IEEE 802.11a / Ant. 1 + Ant. 3

Channel	Frequency	Peak Excursion (dB)	Max. Limit (dB)	Result
36	5180 MHz	5.29	13	Complies
40	5200 MHz	5.47	13	Complies
48	5240 MHz	5.69	13	Complies

Note: All the test values were listed in the report.

For plots, only the channel with maximum results was shown.

Peak Excursion Plot on Configuration IEEE 802.11n MCS0 20MHz / Ant. 1 + Ant. 3 / 5240 MHz

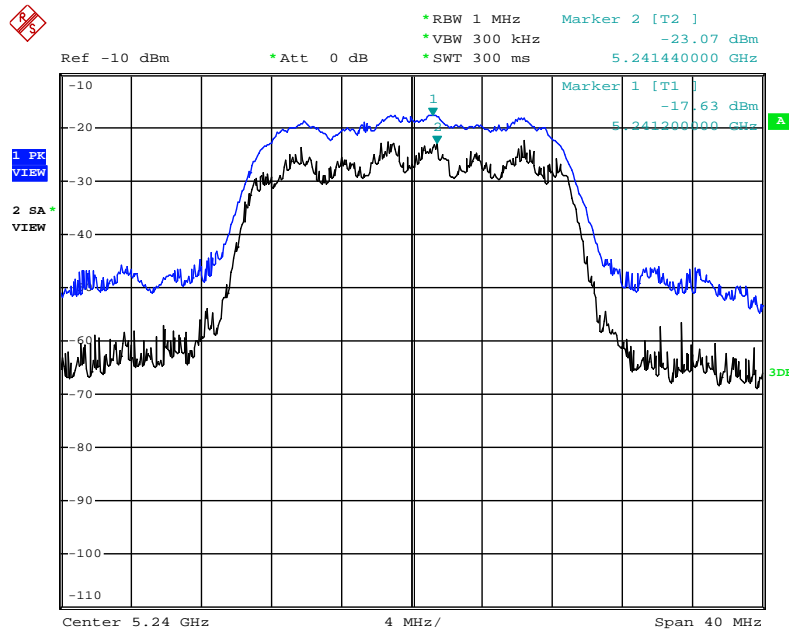

Date: 3.NOV.2011 14:14:52

Peak Excursion Plot on Configuration IEEE 802.11n MCS0 40MHz / Ant. 1 + Ant. 3 / 5190 MHz

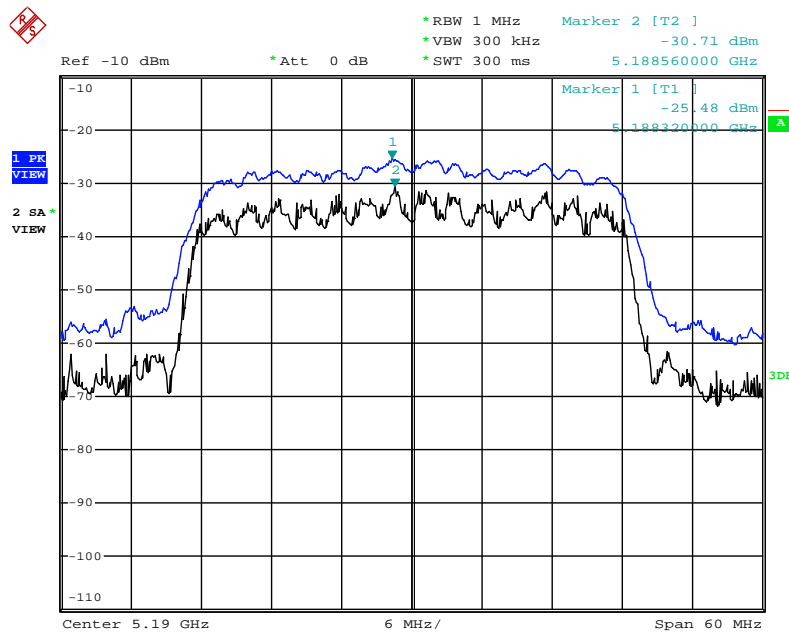

Date: 3.NOV.2011 14:10:22

Peak Excursion Plot on Configuration IEEE 802.11a / Ant. 1 + Ant. 3 / 5240 MHz

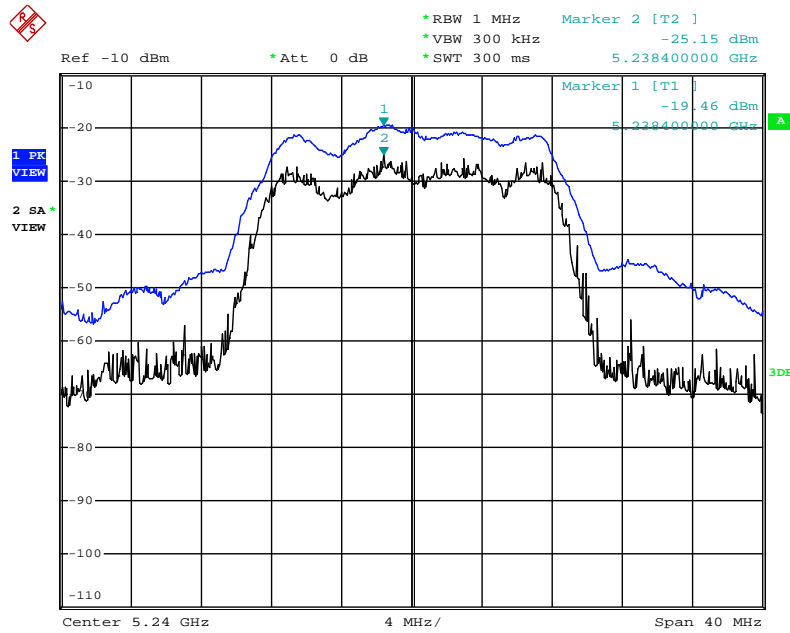

Date: 3.NOV.2011 14:36:57

4.6. Radiated Emissions Measurement

4.6.1. Limit

For transmitters operating in the 5.15-5.25 GHz band: all emissions outside of the 5.15-5.35 GHz band shall not exceed an EIRP of -27 dBm/MHz (68.3dBuV/m at 3m). In addition, In case the emission fall within the restricted band specified on 15.205(a), then the 15.209(a) limit in the table below has to be followed.

Frequencies (MHz)	Field Strength (micorvolts/meter)	Measurement Distance (meters)
0.009~0.490	2400/F(KHz)	300
0.490~1.705	24000/F(KHz)	30
1.705~30.0	30	30
30~88	100	3
88~216	150	3
216~960	200	3
Above 960	500	3

4.6.2. Measuring Instruments and Setting

Please refer to section 5 of equipments list in this report. The following table is the setting of spectrum analyzer and receiver.

Spectrum Parameter	Setting
Attenuation	Auto
Start Frequency	1000 MHz
Stop Frequency	40 GHz
RB / VB (Emission in restricted band)	1MHz / 1MHz for Peak, 1 MHz / 10Hz for Average
RB / VB (Emission in non-restricted band)	1000KHz / 1000KHz for peak

Receiver Parameter	Setting
Attenuation	Auto
Start ~ Stop Frequency	9kHz~150kHz / RB 200Hz for QP
Start ~ Stop Frequency	150kHz~30MHz / RB 9kHz for QP
Start ~ Stop Frequency	30MHz~1000MHz / RB 120kHz for QP

4.6.3. Test Procedures

1. Configure the EUT according to ANSI C63.10. The EUT was placed on the top of the turntable 0.8 meter above ground. The phase center of the receiving antenna mounted on the top of a height-variable antenna tower was placed 3 meters far away from the turntable.
2. Power on the EUT and all the supporting units. The turntable was rotated by 360 degrees to determine the position of the highest radiation.
3. The height of the broadband receiving antenna was varied between one meter and four meters above ground to find the maximum emissions field strength of both horizontal and vertical polarization.
4. For each suspected emissions, the antenna tower was scan (from 1 M to 4 M) and then the turntable was rotated (from 0 degree to 360 degrees) to find the maximum reading.
5. Set the test-receiver system to Peak or CISPR quasi-peak Detect Function with specified bandwidth under Maximum Hold Mode.
6. For emissions above 1GHz, use 1MHz VBW and RBW for peak reading. Then 1MHz RBW and 10Hz VBW for average reading in spectrum analyzer.
7. When the radiated emissions limits are expressed in terms of the average value of the emissions, and pulsed operation is employed, the measurement field strength shall be determined by averaging over one complete pulse train, including blanking intervals, as long as the pulse train does not exceed 0.1 seconds. As an alternative (provided the transmitter operates for longer than 0.1 seconds) or in cases where the pulse train exceeds 0.1 seconds, the measured field strength shall be determined from the average absolute voltage during a 0.1 second interval during which the field strength is at its maximum value.
8. If the emissions level of the EUT in peak mode was 3 dB lower than the average limit specified, then testing will be stopped and peak values of EUT will be reported, otherwise, the emissions which do not have 3 dB margin will be repeated one by one using the quasi-peak method for below 1GHz.
9. For testing above 1GHz, the emissions level of the EUT in peak mode was lower than average limit (that means the emissions level in peak mode also complies with the limit in average mode), then testing will be stopped and peak values of EUT will be reported, otherwise, the emissions will be measured in average mode again and reported.
10. In case the emission is lower than 30MHz, loop antenna has to be used for measurement and the recorded data should be QP measured by receiver. High – Low scan is not required in this case.

4.6.4. Test Setup Layout

For radiated emissions below 1GHz

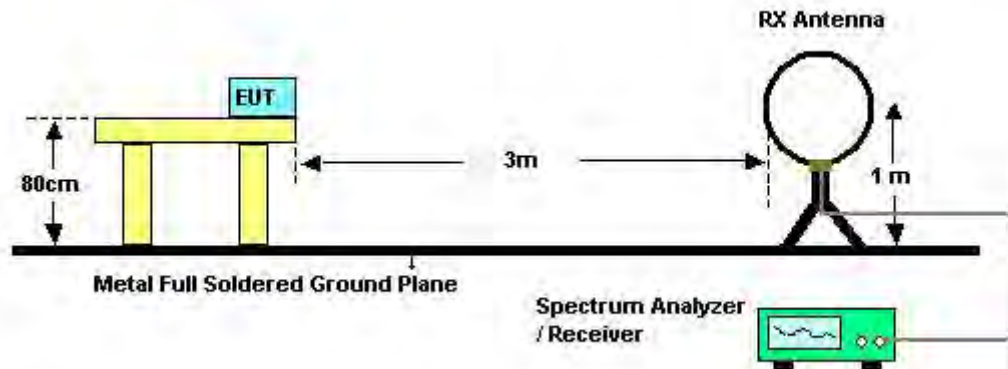

For radiated emissions above 1GHz

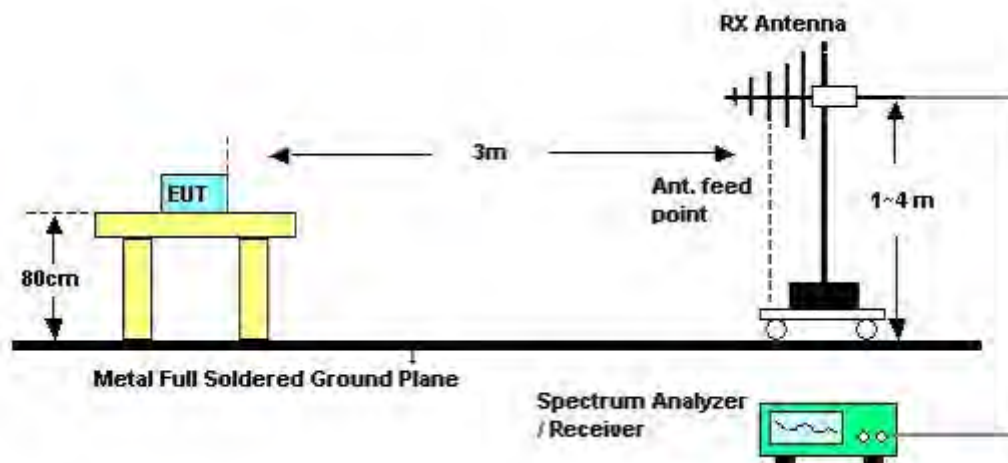

4.6.5. Test Deviation

There is no deviation with the original standard.

4.6.6. EUT Operation during Test

The EUT was programmed to be in continuously transmitting mode.

4.6.7. Results of Radiated Emissions (9kHz~30MHz)

Temperature	26°C	Humidity	60%
Test Engineer	Denis Su	Configurations	Normal Link
Test Date	Nov. 03, 2011		

Freq. (MHz)	Level (dBuV)	Over Limit (dB)	Limit Line (dBuV)	Remark
-	-	-	-	See Note

Note:

The amplitude of spurious emissions that are attenuated by more than 20dB below the permissible value has no need to be reported.

Distance extrapolation factor = $40 \log(\text{specific distance} / \text{test distance})$ (dB);

Limit line = specific limits (dBuV) + distance extrapolation factor.

4.6.8. Results of Radiated Emissions (30MHz~1GHz)

Temperature	26°C	Humidity	60%
Test Engineer	Denis Su	Configurations	Normal Link
Test Mode	Mode 2		

Horizontal

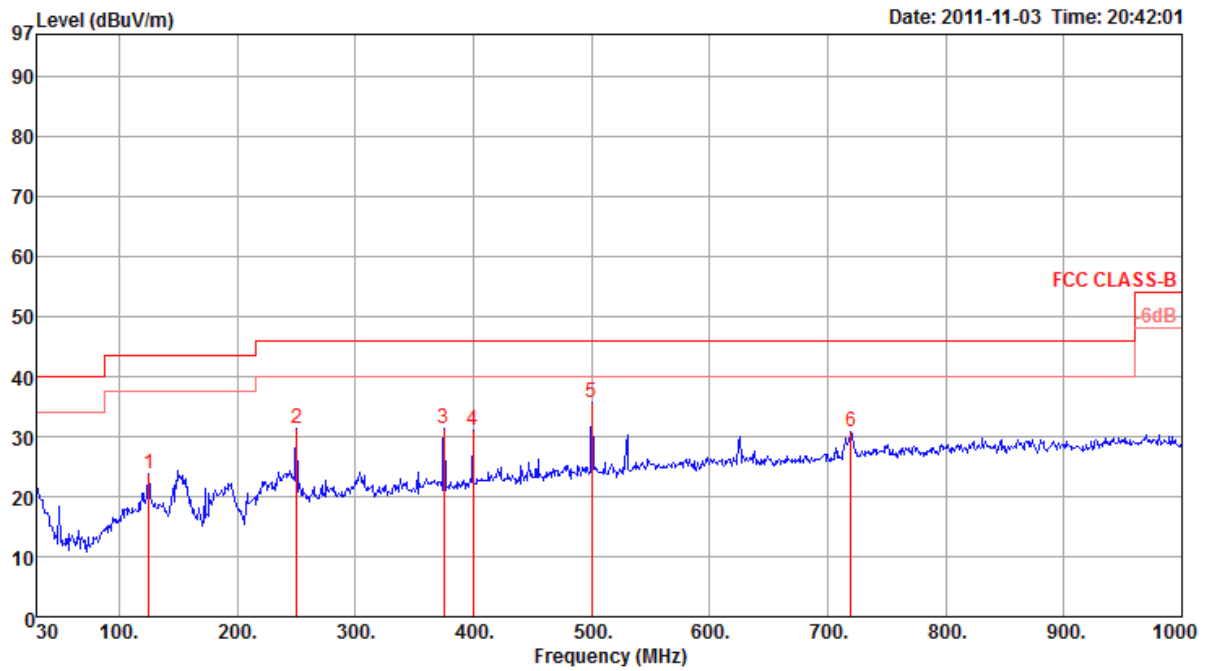

	Freq	Level	Limit	Over	Read	Cable	Preamp	Antenna	T/Pos	A/Pos	Remark	Pol/Phase
	MHz	dBuV/m	dBuV/m	dB	dBuV	dB	dB	dB/m	deg	cm		
1	125.06	23.78	43.50	-19.72	37.08	1.65	27.48	12.53	0	400	Peak	HORIZONTAL
2	250.19	31.34	46.00	-14.66	43.21	2.38	27.00	12.75	0	400	Peak	HORIZONTAL
3	375.32	31.45	46.00	-14.55	40.38	2.89	27.43	15.61	0	400	Peak	HORIZONTAL
4	399.57	31.08	46.00	-14.92	39.21	2.99	27.60	16.48	0	400	Peak	HORIZONTAL
5	500.45	35.62	46.00	-10.38	42.24	3.38	28.10	18.10	0	400	Peak	HORIZONTAL
6	719.67	30.75	46.00	-15.25	34.26	4.18	27.92	20.23	0	400	Peak	HORIZONTAL

Vertical

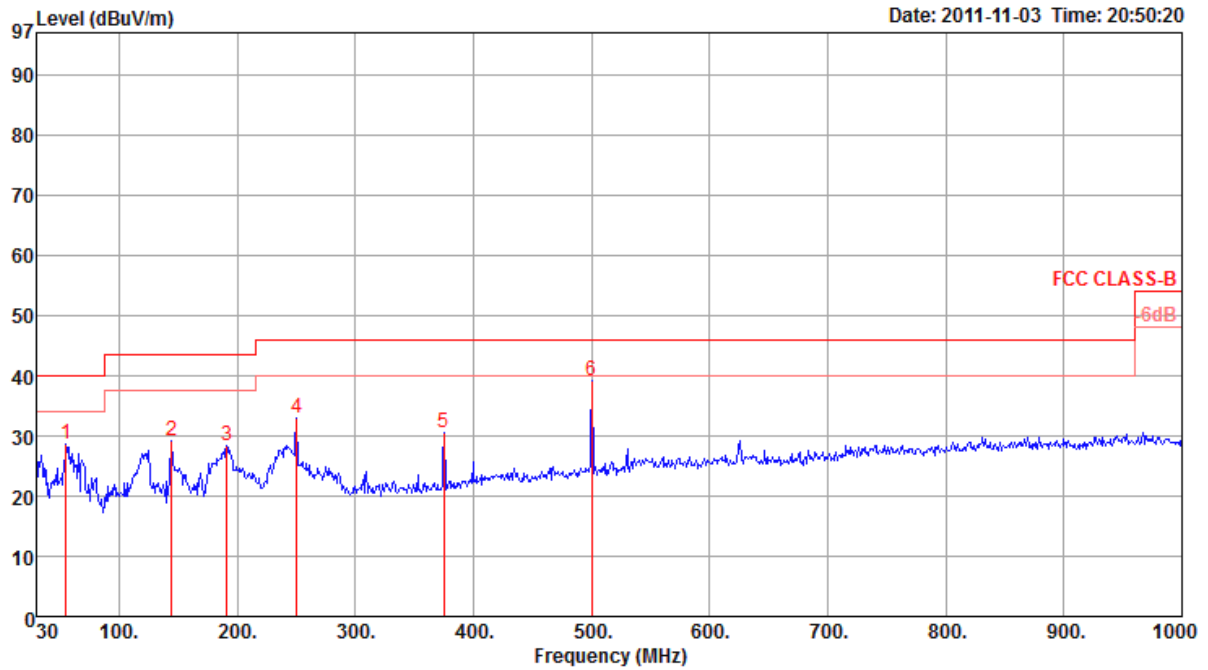

	Freq	Level	Limit	Over	Read	Cable	Preamp	Antenna	T/Pos	A/Pos	Remark	Pol/Phase
	MHz	dBuV/m	dBuV/m	dB	dBuV	dB	dB	dB/m	deg	cm		
1	55.22	28.75	40.00	-11.25	48.47	1.13	27.78	6.93	0	400	Peak	VERTICAL
2	144.46	29.25	43.50	-14.25	44.03	1.75	27.38	10.85	0	400	Peak	VERTICAL
3	191.02	28.46	43.50	-15.04	44.22	2.05	27.14	9.33	0	400	Peak	VERTICAL
4	250.19	32.86	46.00	-13.14	44.73	2.38	27.00	12.75	0	400	Peak	VERTICAL
5	375.32	30.51	46.00	-15.49	39.44	2.89	27.43	15.61	0	400	Peak	VERTICAL
6 p	500.45	39.04	46.00	-6.96	45.66	3.38	28.10	18.10	0	400	Peak	VERTICAL

Note:

The amplitude of spurious emissions that are attenuated by more than 20dB below the permissible value has no need to be reported.

Emission level (dBuV/m) = 20 log Emission level (uV/m).

Corrected Reading: Antenna Factor + Cable Loss + Read Level - Preamp Factor = Level.

4.6.9. Results for Radiated Emissions (1GHz~40GHz)

Temperature	26°C	Humidity	60%
Test Engineer	Denis Su	Configurations	IEEE 802.11n MCS0 20MHz Ch 36 / Ant. 1 + Ant. 3
Test Date	Oct. 25, 2011		

Horizontal

	Freq	Level	Limit Line	Over Limit	Read Level	Cable Loss	Antenna Factor	Preamp Factor	Remark	A/Pos	T/Pos	Pol/Phase
	MHz	dBuV/m	dBuV/m	dB	dBuV	dB	dB/m	dB		cm	deg	
1	15537.21	44.52	54.00	-9.48	36.01	6.13	37.67	35.29	Average	100	138	HORIZONTAL
2	15537.69	60.93	74.00	-13.07	52.42	6.13	37.67	35.29	Peak	100	138	HORIZONTAL

Vertical

	Freq	Level	Limit Line	Over Limit	Read Level	Cable Loss	Antenna Factor	Preamp Factor	Remark	A/Pos	T/Pos	Pol/Phase
	MHz	dBuV/m	dBuV/m	dB	dBuV	dB	dB/m	dB		cm	deg	
1	15534.42	60.57	74.00	-13.43	52.00	6.13	37.73	35.29	Peak	100	54	VERTICAL
2	15536.99	43.69	54.00	-10.31	35.12	6.13	37.73	35.29	Average	100	54	VERTICAL



Temperature	26°C	Humidity	60%
Test Engineer	Denis Su	Configurations	IEEE 802.11n MCS0 20MHz Ch 40 / Ant. 1 + Ant. 3
Test Date	Oct. 25, 2011		

Horizontal

	Freq	Level	Limit Line	Over Limit	Read Level	Cable Loss	Antenna Factor	Preamp Factor	Remark	A/Pos	T/Pos	Pol/Phase
	MHz	dBuV/m	dBuV/m	dB	dBuV	dB	dB/m	dB		cm	deg	
1	15594.49	65.46	74.00	-8.54	57.07	6.13	37.60	35.34	Peak	100	136	HORIZONTAL
2	15597.24	49.12	54.00	-4.88	40.73	6.13	37.60	35.34	Average	100	136	HORIZONTAL

Vertical

	Freq	Level	Limit Line	Over Limit	Read Level	Cable Loss	Antenna Factor	Preamp Factor	Remark	A/Pos	T/Pos	Pol/Phase
	MHz	dBuV/m	dBuV/m	dB	dBuV	dB	dB/m	dB		cm	deg	
1	15599.01	63.92	74.00	-10.08	55.53	6.13	37.60	35.34	Peak	103	73	VERTICAL
2	15599.62	48.29	54.00	-5.71	39.90	6.13	37.60	35.34	Average	103	73	VERTICAL



Temperature	26°C	Humidity	60%
Test Engineer	Denis Su	Configurations	IEEE 802.11n MCS0 20MHz Ch 48 / Ant. 1 + Ant. 3
Test Date	Oct. 25, 2011		

Horizontal

	Freq	Level	Limit Line	Over Limit	Read Level	Cable Loss	Antenna Factor	Preamp Factor	Remark	A/Pos	T/Pos	Pol/Phase
	MHz	dBuV/m	dBuV/m	dB	dBuV	dB	dB/m	dB		cm	deg	
1	15716.88	49.14	54.00	-4.86	40.91	6.14	37.48	35.39	Average	111	127	HORIZONTAL
2	15724.41	65.26	74.00	-8.74	57.03	6.14	37.48	35.39	Peak	111	127	HORIZONTAL

Vertical

	Freq	Level	Limit Line	Over Limit	Read Level	Cable Loss	Antenna Factor	Preamp Factor	Remark	A/Pos	T/Pos	Pol/Phase
	MHz	dBuV/m	dBuV/m	dB	dBuV	dB	dB/m	dB		cm	deg	
1	15720.24	47.50	54.00	-6.50	39.27	6.14	37.48	35.39	Average	102	116	VERTICAL
2	15720.40	62.64	74.00	-11.36	54.41	6.14	37.48	35.39	Peak	102	116	VERTICAL

Temperature	26°C	Humidity	60%
Test Engineer	Denis Su	Configurations	IEEE 802.11n MCS0 40MHz Ch 38 / Ant. 1 + Ant. 3
Test Date	Oct. 25, 2011		

Horizontal

	Freq	Level	Limit Line	Over Limit	Read Level	Cable Loss	Antenna Factor	Preamp Factor	Remark	A/Pos	T/Pos	Pol/Phase
	MHz	dBuV/m	dBuV/m	dB	dBuV	dB	dB/m	dB		cm	deg	
1	15572.08	38.13	54.00	-15.87	29.72	6.13	37.61	35.33	Average	100	137	HORIZONTAL
2	15576.35	50.20	74.00	-23.80	41.79	6.13	37.61	35.33	Peak	100	189	HORIZONTAL

Vertical

	Freq	Level	Limit Line	Over Limit	Read Level	Cable Loss	Antenna Factor	Preamp Factor	Remark	A/Pos	T/Pos	Pol/Phase
	MHz	dBuV/m	dBuV/m	dB	dBuV	dB	dB/m	dB		cm	deg	
1	15567.24	50.78	74.00	-23.22	42.35	6.13	37.63	35.33	Peak	100	260	VERTICAL
2	15576.22	38.24	54.00	-15.76	29.83	6.13	37.61	35.33	Average	100	260	VERTICAL

Temperature	26°C	Humidity	60%
Test Engineer	Denis Su	Configurations	IEEE 802.11n MCS0 40MHz Ch 46 / Ant. 1 + Ant. 3
Test Date	Oct. 18, 2011		

Horizontal

	Freq	Level	Limit	Over	Read	Cable	Antenna	Preamp	Remark	A/Pos	T/Pos	Pol/Phase
	MHz	dBuV/m	dBuV/m	dB	dBuV	dB	dB/m	dB		cm	deg	
1	15689.36	41.89	54.00	-12.11	33.61	6.14	37.51	35.37	Average	102	128	HORIZONTAL
2	15691.76	56.82	74.00	-17.18	48.57	6.14	37.49	35.38	Peak	102	128	HORIZONTAL

Vertical

	Freq	Level	Limit	Over	Read	Cable	Antenna	Preamp	Remark	A/Pos	T/Pos	Pol/Phase
	MHz	dBuV/m	dBuV/m	dB	dBuV	dB	dB/m	dB		cm	deg	
1	15691.60	57.59	74.00	-16.41	49.34	6.14	37.49	35.38	Peak	111	53	VERTICAL
2	15692.08	41.78	54.00	-12.22	33.53	6.14	37.49	35.38	Average	111	53	VERTICAL

Note:

The amplitude of spurious emissions that are attenuated by more than 20dB below the permissible value has no need to be reported.

Emission level (dBuV/m) = 20 log Emission level (uV/m).

Corrected Reading: Antenna Factor + Cable Loss + Read Level - Preamp Factor = Level.

Temperature	26°C	Humidity	60%
Test Engineer	Denis Su	Configurations	IEEE 802.11a Ch 36 / Ant. 1 + Ant. 3
Test Date	Oct. 17, 2011		

Horizontal

	Freq	Level	Limit Line	Over Limit	Read Level	Cable Loss	Antenna Factor	Preamp Factor	Remark	A/Pos	T/Pos	Pol/Phase
	MHz	dBuV/m	dBuV/m	dB	dBuV	dB	dB/m	dB		cm	deg	
1	15539.04	44.14	60.00	-15.86	35.67	6.13	37.65	35.31	Average	100	133	HORIZONTAL
2	15543.53	58.86	74.00	-15.14	50.39	6.13	37.65	35.31	Peak	100	133	HORIZONTAL

Vertical

	Freq	Level	Limit Line	Over Limit	Read Level	Cable Loss	Antenna Factor	Preamp Factor	Remark	A/Pos	T/Pos	Pol/Phase
	MHz	dBuV/m	dBuV/m	dB	dBuV	dB	dB/m	dB		cm	deg	
1	15538.88	42.49	54.00	-11.51	33.98	6.13	37.69	35.31	Average	110	36	VERTICAL
2	15543.61	57.98	74.00	-16.02	49.47	6.13	37.69	35.31	Peak	110	36	VERTICAL



Temperature	26°C	Humidity	60%
Test Engineer	Denis Su	Configurations	IEEE 802.11a Ch 40 / Ant. 1 + Ant. 3
Test Date	Oct. 25, 2011		

Horizontal

	Freq	Level	Limit Line	Over Limit	Read Level	Cable Loss	Antenna Factor	Preamp Factor	Remark	A/Pos	T/Pos	Pol/Phase
	MHz	dBuV/m	dBuV/m	dB	dBuV	dB	dB/m	dB		cm	deg	
1	15598.65	50.13	54.00	-3.87	41.74	6.13	37.60	35.34	Average	100	140	HORIZONTAL
2	15603.56	66.66	74.00	-7.34	58.27	6.13	37.60	35.34	Peak	100	140	HORIZONTAL

Vertical

	Freq	Level	Limit Line	Over Limit	Read Level	Cable Loss	Antenna Factor	Preamp Factor	Remark	A/Pos	T/Pos	Pol/Phase
	MHz	dBuV/m	dBuV/m	dB	dBuV	dB	dB/m	dB		cm	deg	
1	15598.62	51.65	54.00	-2.35	43.26	6.13	37.60	35.34	Average	105	52	VERTICAL
2	15603.49	67.74	74.00	-6.26	59.35	6.13	37.60	35.34	Peak	105	52	VERTICAL



Temperature	26°C	Humidity	60%
Test Engineer	Denis Su	Configurations	IEEE 802.11a Ch 48 / Ant. 1 + Ant. 3
Test Date	Oct. 18, 2011		

Horizontal

	Freq	Level	Limit Line	Over Limit	Read Level	Cable Loss	Antenna Factor	Preamp Factor	Remark	A/Pos	T/Pos	Pol/Phase
	MHz	dBuV/m	dBuV/m	dB	dBuV	dB	dB/m	dB		cm	deg	
1	15717.84	43.78	54.00	-10.22	35.55	6.14	37.48	35.39	Average	100	113	HORIZONTAL
2	15723.45	59.05	74.00	-14.95	50.82	6.14	37.48	35.39	Peak	100	113	HORIZONTAL

Vertical

	Freq	Level	Limit Line	Over Limit	Read Level	Cable Loss	Antenna Factor	Preamp Factor	Remark	A/Pos	T/Pos	Pol/Phase
	MHz	dBuV/m	dBuV/m	dB	dBuV	dB	dB/m	dB		cm	deg	
1	15717.76	47.83	54.00	-6.17	39.60	6.14	37.48	35.39	Average	106	36	VERTICAL
2	15723.45	63.62	74.00	-10.38	55.39	6.14	37.48	35.39	Peak	106	36	VERTICAL

Note:

The amplitude of spurious emissions that are attenuated by more than 20dB below the permissible value has no need to be reported.

Emission level (dBuV/m) = 20 log Emission level (uV/m).

Corrected Reading: Antenna Factor + Cable Loss + Read Level - Preamp Factor = Level.

4.7. Band Edge Emissions Measurement

4.7.1. Limit

For transmitters operating in the 5.15-5.25 GHz band: all emissions outside of the 5.15-5.25 GHz band shall not exceed an EIRP of -27 dBm/MHz (68.3dBuV/m at 3m). In addition, In case the emission fall within the restricted band specified on 15.205(a), then the 15.209(a) limit in the table below has to be followed.

Frequencies (MHz)	Field Strength (micorvolts/meter)	Measurement Distance (meters)
0.009~0.490	2400/F(KHz)	300
0.490~1.705	24000/F(KHz)	30
1.705~30.0	30	30
30~88	100	3
88~216	150	3
216~960	200	3
Above 960	500	3

4.7.2. Measuring Instruments and Setting

Please refer to section 5 of equipments list in this report. The following table is the setting of the spectrum analyzer.

Spectrum Parameter	Setting
Attenuation	Auto
Span Frequency	100 MHz
RB / VB (Emission in restricted band)	1MHz / 1MHz for Peak, 1 MHz / 10Hz for Average
RB / VB (Emission in non-restricted band)	1 MHz /1 MHz for Peak

4.7.3. Test Procedures

1. The test procedure is the same as section 4.6.3, only the frequency range investigated is limited to 100MHz around bandedges.
2. In case the emission is fail due to the used RB/VB is too wide, marker-delta method of FCC Public Notice DA00-705 will be followed.

4.7.4. Test Setup Layout

This test setup layout is the same as that shown in section 4.6.4.

4.7.5. Test Deviation

There is no deviation with the original standard.

4.7.6. EUT Operation during Test

The EUT was programmed to be in continuously transmitting mode.

4.7.7. Test Result of Band Edge and Fundamental Emissions

Temperature	26°C	Humidity	60%
Test Engineer	Denis Su	Configurations	IEEE 802.11n MCS0 20MHz Ch 36 / Ant. 1 + Ant. 3
Test Date	Oct. 17, 2011		

Channel 36

	Freq	Level	Limit Line	Over Limit	Read Level	CableAntenna Loss	Antenna Factor	Preamp Factor	Remark	A/Pos	T/Pos	Pol/Phase
	MHz	dBuV/m	dBuV/m	dB	dBuV	dB	dB/m	dB		cm	deg	
1	5148.56	79.28	80.00	-0.72	42.18	3.43	33.67	0.00	Peak	100	295	VERTICAL
2	5149.04	59.36	60.00	-0.64	22.26	3.43	33.67	0.00	Average	100	295	VERTICAL
3	5181.28	102.01				3.44	33.73	0.00	Average	100	295	VERTICAL
4	5181.28	118.98				3.44	33.73	0.00	Peak	100	295	VERTICAL

Item 3, 4 are the fundamental frequency at 5180 MHz.

Temperature	26°C	Humidity	60%
Test Engineer	Denis Su	Configurations	IEEE 802.11n MCS0 20MHz Ch 40 / Ant. 1 + Ant. 3
Test Date	Nov. 01, 2011		

Channel 40

	Freq	Level	Limit Line	Over Limit	Read Level	CableAntenna Loss	Antenna Factor	Preamp Factor	Remark	A/Pos	T/Pos	Pol/Phase
	MHz	dBuV/m	dBuV/m	dB	dBuV	dB	dB/m	dB		cm	deg	
1	5148.72	58.62	60.00	-1.38	21.52	3.43	33.67	0.00	Average	100	287	VERTICAL
2	5148.72	76.64	80.00	-3.36	39.54	3.43	33.67	0.00	Peak	100	287	VERTICAL
3	5198.72	103.25				3.45	33.76	0.00	Average	100	287	VERTICAL
4	5200.96	122.82				3.45	33.76	0.00	Peak	100	287	VERTICAL

Item 3, 4 are the fundamental frequency at 5200 MHz.



Temperature	26°C	Humidity	60%
Test Engineer	Denis Su	Configurations	IEEE 802.11n MCS0 20MHz Ch 48 / Ant. 1 + Ant. 3
Test Date	Oct. 18, 2011		

Channel 48

	Freq	Level	Limit Line	Over Limit	Read Level	Cable Loss	Antenna Factor	Preamp Factor	Remark	A/Pos	T/Pos	Pol/Phase
	MHz	dBuV/m	dBuV/m	dB	dBuV	dB	dB/m	dB		cm	deg	
1	5148.56	54.52	60.00	-5.48	17.42	3.43	33.67	0.00	Average	100	335	VERTICAL
2	5150.00	71.73	80.00	-8.27	34.63	3.43	33.67	0.00	Peak	100	335	VERTICAL
3	5239.04	125.34				3.46	33.82	0.00	Peak	100	335	VERTICAL
4	5241.44	106.95				3.46	33.82	0.00	Average	100	335	VERTICAL
5	5350.00	52.84	60.00	-7.16	15.32	3.49	34.03	0.00	Average	100	335	VERTICAL
6	5351.92	64.41	80.00	-15.59	26.89	3.49	34.03	0.00	Peak	100	335	VERTICAL

Item 3, 4 are the fundamental frequency at 5240 MHz.

Temperature	26°C	Humidity	60%
Test Engineer	Denis Su	Configurations	IEEE 802.11n MCS0 40MHz Ch 38 / Ant. 1 + Ant. 3
Test Date	Oct. 17, 2011		

Channel 38

	Freq	Level	Limit Line	Over Limit	Read Level	Cable Loss	Antenna Factor	Preamp Factor	Remark	A/Pos	T/Pos	Pol/Phase
	MHz	dBuV/m	dBuV/m	dB	dBuV	dB	dB/m	dB		cm	deg	
1	5146.47	76.28	80.00	-3.72	39.18	3.43	33.67	0.00	Peak	100	298	VERTICAL
2	5148.40	59.92	60.00	-0.08	22.82	3.43	33.67	0.00	Average	100	298	VERTICAL
3	5188.08	111.14				3.44	33.73	0.00	Peak	100	298	VERTICAL
4	5188.72	92.97				3.44	33.73	0.00	Average	100	298	VERTICAL

Item 3, 4 are the fundamental frequency at 5190 MHz.

Temperature	26°C	Humidity	60%
Test Engineer	Denis Su	Configurations	IEEE 802.11n MCS0 40MHz Ch 46 / Ant. 1 + Ant. 3
Test Date	Oct. 18, 2011		

Channel 46

	Freq	Level	Limit Line	Over Limit	Read Level	Cable Loss	Antenna Factor	Preamp Factor	Remark	A/Pos	T/Pos	Pol/Phase
	MHz	dBuV/m	dBuV/m	dB	dBuV	dB	dB/m	dB		cm	deg	
1	5143.91	76.35	80.00	-3.65	39.25	3.43	33.67	0.00	Peak	100	290	VERTICAL
2	5149.04	58.45	60.00	-1.55	21.35	3.43	33.67	0.00	Average	100	290	VERTICAL
3	5231.60	98.06				3.46	33.82	0.00	Average	100	290	VERTICAL
4	5231.60	117.24				3.46	33.82	0.00	Peak	100	290	VERTICAL

Item 3, 4 are the fundamental frequency at 5230 MHz.

Note:

Emission level (dBuV/m) = 20 log Emission level (uV/m)

Corrected Reading: Antenna Factor + Cable Loss + Read Level - Preamp Factor = Level

Temperature	26°C	Humidity	60%
Test Engineer	Denis Su	Configurations	IEEE 802.11a Ch 36 / Ant. 1 + Ant. 3
Test Date	Oct. 17, 2011		

Channel 36

	Freq	Level	Limit Line	Over Limit	Read Level	CableAntenna Loss	Antenna Factor	Preamp Factor	Remark	A/Pos	T/Pos	Pol/Phase
	MHz	dBuV/m	dBuV/m	dB	dBuV	dB	dB/m	dB		cm	deg	
1	5149.68	79.51	80.00	-0.49	42.41	3.43	33.67	0.00	Peak	137	283	VERTICAL
2	5149.84	59.35	60.00	-0.65	22.25	3.43	33.67	0.00	Average	137	283	VERTICAL
3	5179.36	101.27				3.44	33.73	0.00	Average	137	283	VERTICAL
4	5179.36	116.67				3.44	33.73	0.00	Peak	137	283	VERTICAL

Item 3, 4 are the fundamental frequency at 5180 MHz.

Temperature	26°C	Humidity	60%
Test Engineer	Denis Su	Configurations	IEEE 802.11a Ch 40 / Ant. 1 + Ant. 3
Test Date	Nov. 01, 2011		

Channel 40

	Freq	Level	Limit Line	Over Limit	Read Level	CableAntenna Loss	Antenna Factor	Preamp Factor	Remark	A/Pos	T/Pos	Pol/Phase
	MHz	dBuV/m	dBuV/m	dB	dBuV	dB	dB/m	dB		cm	deg	
1	5147.44	58.50	60.00	-1.50	21.40	3.43	33.67	0.00	Average	100	287	VERTICAL
2	5147.44	79.34	80.00	-0.66	42.24	3.43	33.67	0.00	Peak	100	287	VERTICAL
3	5201.60	123.65				3.45	33.76	0.00	Peak	100	287	VERTICAL
4	5206.73	103.77				3.45	33.76	0.00	Average	100	287	VERTICAL

Item 3, 4 are the fundamental frequency at 5200 MHz.



Temperature	26°C	Humidity	60%
Test Engineer	Denis Su	Configurations	IEEE 802.11a Ch 48 / Ant. 1 + Ant. 3
Test Date	Oct. 18, 2011		

Channel 48

	Freq	Level	Limit Line	Over Limit	Read Level	Cable Loss	Antenna Factor	Preamp Factor	Remark	A/Pos	T/Pos	Pol/Phase
	MHz	dBuV/m	dBuV/m	dB	dBuV	dB	dB/m	dB		cm	deg	
1	5150.00	53.49	60.00	-6.51	16.39	3.43	33.67	0.00	Average	110	283	VERTICAL
2	5150.00	64.49	80.00	-15.51	27.39	3.43	33.67	0.00	Peak	110	283	VERTICAL
3	5240.96	106.15				3.46	33.82	0.00	Average	110	283	VERTICAL
4	5240.96	121.82				3.46	33.82	0.00	Peak	110	283	VERTICAL
5	5350.00	53.45	60.00	-6.55	15.93	3.49	34.03	0.00	Average	110	283	VERTICAL
6	5352.40	64.32	80.00	-15.68	26.80	3.49	34.03	0.00	Peak	110	283	VERTICAL

Item 3, 4 are the fundamental frequency at 5240 MHz.

Note:

Emission level (dBuV/m) = 20 log Emission level (uV/m)

Corrected Reading: Antenna Factor + Cable Loss + Read Level - Preamp Factor = Level

4.8. Frequency Stability Measurement

4.8.1. Limit

Manufacturers of U-NII devices are responsible for ensuring frequency stability such that an emissions is maintained within the band of operation under all conditions of normal operation as specified in the user's manual or $\pm 20\text{ppm}$ (IEEE 802.11 specification).

4.8.2. Measuring Instruments and Setting

Please refer to section 5 of equipments list in this report. The following table is the setting of the spectrum analyzer.

Spectrum Parameter	Setting
Attenuation	Auto
Span Frequency	Entire absence of modulation emissions bandwidth
RB	10 kHz
VB	10 kHz
Sweep Time	Auto

4.8.3. Test Procedures

1. The transmitter output (antenna port) was connected to the spectrum analyzer.
2. EUT have transmitted absence of modulation signal and fixed channelize.
3. Set the spectrum analyzer span to view the entire absence of modulation emissions bandwidth.
4. Set RBW = 10 kHz, VBW = 10 kHz with peak detector and maxhold settings.
5. f_c is declaring of channel frequency. Then the frequency error formula is $(f_c - f) / f_c \times 10^6$ ppm and the limit is less than $\pm 20\text{ppm}$ (IEEE 802.11 specification).
6. The test extreme voltage is to change the primary supply voltage from 85 to 115 percent of the nominal value
7. Extreme temperature rule is $-30^\circ\text{C} \sim 50^\circ\text{C}$.

4.8.4. Test Setup Layout

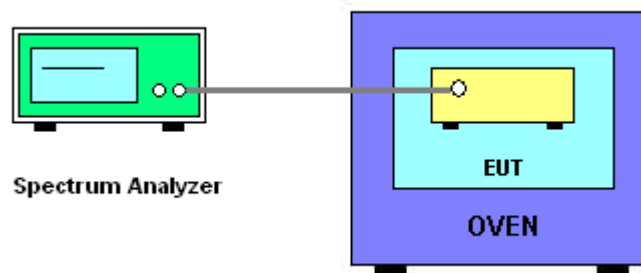

4.8.5. Test Deviation

There is no deviation with the original standard.

4.8.6. EUT Operation during Test

The EUT was programmed to be in continuously un-modulation transmitting mode.

4.8.7. Test Result of Frequency Stability

Voltage vs. Frequency Stability

Voltage	Measurement Frequency (MHz)
(V)	5200
126.50	5200.0342
110.00	5200.0342
93.50	5200.0342
Max. Deviation (MHz)	0.034200
Max. Deviation (ppm)	6.58

Temperature vs. Frequency Stability

Temperature	Measurement Frequency (MHz)
(°C)	5200
-30	5200.0482
-20	5200.0523
-10	5200.0594
0	5200.0618
10	5200.0434
20	5200.0342
30	5200.0162
40	5200.0208
50	5200.0212
Max. Deviation (MHz)	0.061800
Max. Deviation (ppm)	11.88

4.9. Antenna Requirements

4.9.1. Limit

Except for special regulations, the Low-power Radio-frequency Devices must not be equipped with any jacket for installing an antenna with extension cable. An intentional radiator shall be designed to ensure that no antenna other than that furnished by the responsible party shall be used with the device. The use of a permanently attached antenna or of an antenna that uses a unique coupling to the intentional radiator shall be considered sufficient to comply with the provisions of this Section. The manufacturer may design the unit so that the user can replace a broken antenna, but the use of a standard antenna jack or electrical connector is prohibited. Further, this requirement does not apply to intentional radiators that must be professionally installed.

4.9.2. Antenna Connector Construction

Please refer to section 3.3 in this test report; antenna connector complied with the requirements.

5. LIST OF MEASURING EQUIPMENTS

Instrument	Manufacturer	Model No.	Serial No.	Characteristics	Calibration Date	Remark
EMI Test Receiver	R&S	ESCS 30	100377	9kHz ~ 2.75GHz	Sep. 14, 2011	Conduction (CO01-CB)
LISN	F.C.C.	FCC-LISN-50-16-2	04083	150kHz ~ 100MHz	Oct. 28, 2010	Conduction (CO01-CB)
LISN	F.C.C.	FCC-LISN-50-16-2	04083	150kHz ~ 100MHz	Oct. 28, 2011	Conduction (CO01-CB)
V- LISN	Schwarzbeck	NSLK 8127	8127-478	9K ~ 30MHz	Nov. 16, 2010	Conduction (CO01-CB)
PULSE LIMITER	R&S	ESH3-Z2	100430	9K-30MHz	Jan. 04, 2011	Conduction (CO01-CB)
COND Cable	-	Cable	-	0.15MHz~30MHz	Dec. 04, 2010	Conduction (CO01-CB)
BILOG ANTENNA	Schaffner	CBL6112D	22021	20MHz ~ 2GHz	Oct. 29, 2010	Radiation (03CH01-CB)
BILOG ANTENNA	Schaffner	CBL6112D	22021	20MHz ~ 2GHz	Oct. 29, 2011	Radiation (03CH01-CB)
Horn Antenna	EMCO	3115	00075790	750MHz~18GHz	Nov. 22, 2010	Radiation (03CH01-CB)
Horn Antenna	SCHWARZBEAK	BBHA 9170	BBHA9170252	15GHz ~ 40GHz	Nov. 22, 2010	Radiation (03CH01-CB)
Pre-Amplifier	Agilent	8447D	2944A10991	0.1MHz ~ 1.3GHz	Nov. 17, 2010	Radiation (03CH01-CB)
Pre-Amplifier	Agilent	8449B	3008A02310	1GHz ~ 26.5GHz	Nov. 23, 2010	Radiation (03CH01-CB)
Pre-Amplifier	WM	TF-130N-R1	923365	26.5GHz ~ 40GHz	Jul. 29, 2011	Radiation (03CH01-CB)
Spectrum analyzer	R&S	FSP40	100056	9KHz~40GHz	Nov. 03, 2010	Radiation (03CH01-CB)
Spectrum analyzer	R&S	FSP40	100056	9KHz~40GHz	Nov. 03, 2011	Radiation (03CH01-CB)
EMI Test Receiver	R&S	ESCS 30	100355	9KHz ~ 2.75GHz	Mar. 22, 2011	Radiation (03CH01-CB)
Loop Antenna	Teseq	HLA 6120	24155	9 kHz - 30 MHz	Sep. 09, 2010*	Radiation (03CH01-CB)
Turn Table	INN CO	CO 2000	N/A	0 ~ 360 degree	N/A	Radiation (03CH01-CB)
Antenna Mast	INN CO	CO2000	N/A	1 m - 4 m	N/A	Radiation (03CH01-CB)
RF Cable-low	Woken	Low Cable-1	N/A	30 MHz - 1 GHz	Nov. 17, 2010	Radiation (03CH01-CB)
RF Cable-high	Woken	High Cable-1	N/A	1 GHz – 26.5 GHz	Nov. 17, 2010	Radiation (03CH01-CB)
RF Cable-high	Woken	High Cable-2	N/A	1 GHz – 26.5 GHz	Nov. 17, 2010	Radiation (03CH01-CB)
RF Cable-high	Woken	High Cable-3	N/A	1 GHz - 40 GHz	Nov. 17, 2010	Radiation (03CH01-CB)
RF Cable-high	Woken	High Cable-4	N/A	1 GHz - 40 GHz	Nov. 17, 2010	Radiation (03CH01-CB)
Spectrum analyzer	R&S	FSV30	101026	9KHz~30GHz	Jul. 27, 2011	Conducted (TH01-CB)
Thermo-Hygro Meter	N/A	HC 520	#1	15~70 degree	Nov. 02, 2010	Conducted (TH01-CB)

Instrument	Manufacturer	Model No.	Serial No.	Characteristics	Calibration Date	Remark
Thermo-Hygro Meter	N/A	HC 520	#1	15-70 degree	Nov. 02, 2011	Conducted (TH01-CB)
RF Power Divider	HP	11636A	00306	2GHz ~ 18GHz	N/A	Conducted (TH01-CB)
RF Power Splitter	Anaren	44100	1839	2GHz ~ 18GHz	N/A	Conducted (TH01-CB)
RF Power Splitter	Anaren	42100	17930	2GHz ~ 18GHz	N/A	Conducted (TH01-CB)
EPM-P Series Power Meter	Agilent	E4416A	GB41291199	50MHz – 18GHz	Sep. 09, 2011	Conducted (TH01-CB)
Peak an Avg Power Sensor	Agilent	E9327A	US40442088	50MHz – 18GHz	Sep. 09, 2011	Conducted (TH01-CB)
RF Cable-high	Woken	High Cable-7	-	1 GHz – 26.5 GHz	Nov. 17, 2010	Conducted (TH01-CB)
RF Cable-high	Woken	High Cable-8	-	1 GHz – 26.5 GHz	Nov. 17, 2010	Conducted (TH01-CB)
RF Cable-high	Woken	High Cable-9	-	1 GHz – 26.5 GHz	Nov. 17, 2010	Conducted (TH01-CB)
RF Cable-high	Woken	High Cable-10	-	1 GHz – 26.5 GHz	Nov. 17, 2010	Conducted (TH01-CB)
RF Cable-high	Woken	High Cable-11	-	1 GHz – 26.5 GHz	Nov. 17, 2010	Conducted (TH01-CB)
RF Cable-high	Woken	High Cable-12	-	1 GHz – 26.5 GHz	Nov. 17, 2010	Conducted (TH01-CB)
RF Cable-high	Woken	High Cable-13	-	1 GHz – 26.5 GHz	Nov. 17, 2010	Conducted (TH01-CB)
Power Sensor	Anritsu	MA2411B	0917223	300MHz~40GHz	Nov. 01, 2010	Conducted (TH01-CB)
Power Sensor	Anritsu	MA2411B	0917223	300MHz~40GHz	Nov. 01, 2011	Conducted (TH01-CB)
Power Meter	Anritsu	ML2495A	1035008	300MHz~40GHz	Nov. 01, 2010	Conducted (TH01-CB)
Power Meter	Anritsu	ML2495A	1035008	300MHz~40GHz	Nov. 01, 2011	Conducted (TH01-CB)

Note: Calibration Interval of instruments listed above is one year.

“*” Calibration Interval of instruments listed above is two years.

NCR means Non-Calibration required.

6. TEST LOCATION

SHIJR	ADD : 6Fl., No. 106, Sec. 1, Shintai 5th Rd., Shijr City, Taipei, Taiwan 221, R.O.C. TEL : 886-2-2696-2468 FAX : 886-2-2696-2255
HWA YA	ADD : No. 52, Hwa Ya 1st Rd., Kwei-Shan Hsiang, Tao Yuan Hsien, Taiwan, R.O.C. TEL : 886-3-327-3456 FAX : 886-3-318-0055
LINKOU	ADD : No. 30-2, Dingfu Tsuen, Linkou Shiang, Taipei, Taiwan 244, R.O.C TEL : 886-2-2601-1640 FAX : 886-2-2601-1695
DUNGHU	ADD : No. 3, Lane 238, Kangle St., Neihu Chiu, Taipei, Taiwan 114, R.O.C. TEL : 886-2-2631-4739 FAX : 886-2-2631-9740
JUNGHE	ADD : 7Fl., No. 758, Jungjeng Rd., Junghe City, Taipei, Taiwan 235, R.O.C. TEL : 886-2-8227-2020 FAX : 886-2-8227-2626
NEIHU	ADD : 4Fl., No. 339, Hsin Hu 2 nd Rd., Taipei 114, Taiwan, R.O.C. TEL : 886-2-2794-8886 FAX : 886-2-2794-9777
JHUBEI	ADD : No.8, Lane 724, Bo-ai St., Jhubei City, HsinChu County 302, Taiwan, R.O.C. TEL : 886-3-656-9065 FAX : 886-3-656-9085

7. TAF CERTIFICATE OF ACCREDITATION



Certificate No. : L1190-110702

財團法人全國認證基金會
Taiwan Accreditation Foundation

Certificate of Accreditation

This is to certify that

Sporton International Inc.
EMC & Wireless Communications Laboratory
No.52, Hwa Ya 1st Road, Hwa Ya Technology Park, Kwei-Shan Hsiang, Tao Yuan Hsien,
Taiwan, R.O.C.

is accredited in respect of laboratory

Accreditation Criteria	: ISO/IEC 17025:2005
Accreditation Number	: 1190
Originally Accredited	: December 15, 2003
Effective Period	: January 10, 2010 to January 09, 2013
Accredited Scope	: Testing Field, see described in the Appendix
Specific Accreditation Program	: Accreditation Program for Designated Testing Laboratory for Commodities Inspection Accreditation Program for Telecommunication Equipment Testing Laboratory Accreditation Program for BSMI Mutual Recognition Arrangement with Foreign Authorities

Jay-San Chen
President, Taiwan Accreditation Foundation
Date : July 02, 2011

P1, total 22 pages

The Appendix forms an integral part of this Certificate, which shall be invalid when use without the Appendix