



# SPORTON International Inc.

No. 52, Hwa Ya 1st Rd., Kwei-Shan Hsiang, TaoYuan Hsien, Taiwan, R.O.C.  
Ph: 886-3-327-3456 / FAX: 886-3-327-0973 / www.sporton.com.tw

## FCC RADIO TEST REPORT

Applicant's company	NETGEAR, Inc.
Applicant Address	350 East Plumeria Drive, San Jose, California 95134-1911
FCC ID	PY311200166
Manufacturer's company	Ambit Microsystems (Shanghai) Ltd.
Manufacturer Address	No. 1925, Nanle Road, Songjiang Export Processing Zone, Shanghai, China

Product Name	N600 Wireless Dual Band Gigabit Router
Brand Name	NETGEAR
Model Name	WNDR3700v3
Test Rule Part(s)	47 CFR FCC Part 15 Subpart E § 15.407
Test Freq. Range	5150 ~ 5250MHz
Received Date	Dec. 06, 2010
Final Test Date	Oct. 04, 2011
Submission Type	Class II Change
Operating Mode	Master
Multiple Listing	Please refer to section 3.7

### Statement

Test result included is for the IEEE 802.11n and IEEE 802.11a (5150 ~ 5250MHz) of the product.

The test result in this report refers exclusively to the presented test model / sample.

Without written approval of SPORTON International Inc., the test report shall not be reproduced except in full.

The measurements and test results shown in this test report were made in accordance with the procedures and found in compliance with the limit given in ANSI C63.10-2009 and 47 CFR FCC Part 15 Subpart E.

The test equipment used to perform the test is calibrated and traceable to NML/ROC.



Testing Laboratory  
1190



## Table of Contents

<b>1. CERTIFICATE OF COMPLIANCE .....</b>	<b>1</b>
<b>2. SUMMARY OF THE TEST RESULT .....</b>	<b>2</b>
<b>3. GENERAL INFORMATION .....</b>	<b>3</b>
3.1. Product Details.....	3
3.2. Accessories.....	5
3.3. Table for Filed Antenna.....	5
3.4. Table for Carrier Frequencies .....	6
3.5. Table for Test Modes .....	7
3.6. Table for Testing Locations.....	8
3.7. Table for Class II Change .....	8
3.8. Table for Supporting Units .....	8
3.9. Table for Parameters of Test Software Setting .....	9
3.10. Test Configurations .....	10
<b>4. TEST RESULT .....</b>	<b>12</b>
4.1. AC Power Line Conducted Emissions Measurement.....	12
4.2. 99% Occupied Bandwidth Measurement .....	16
4.3. Maximum Conducted Output Power Measurement.....	31
4.4. Power Spectral Density Measurement .....	37
4.5. Peak Excursion Measurement .....	48
4.6. Radiated Emissions Measurement .....	57
4.7. Band Edge Emissions Measurement .....	95
4.8. Frequency Stability Measurement .....	102
4.9. Antenna Requirements .....	104
<b>5. LIST OF MEASURING EQUIPMENTS .....</b>	<b>105</b>
<b>6. TEST LOCATION.....</b>	<b>107</b>
<b>7. TAF CERTIFICATE OF ACCREDITATION .....</b>	<b>108</b>
<b>APPENDIX A. TEST PHOTOS .....</b>	<b>A1 ~ A6</b>
<b>APPENDIX B. MAXIMUM PERMISSIBLE EXPOSURE .....</b>	<b>B1 ~ B3</b>



## History of This Test Report

REPORT NO.	VERSION	DESCRIPTION	ISSUED DATE
FR0D1643-04AA	Rev. 01	Initial issue of report	Oct. 26, 2011



## 1. CERTIFICATE OF COMPLIANCE

Product Name : N600 Wireless Dual Band Gigabit Router  
Brand Name : NETGEAR  
Model Name : WNDR3700v3  
Applicant : NETGEAR, Inc.  
Test Rule Part(s) : 47 CFR FCC Part 15 Subpart E § 15.407

Sporton International as requested by the applicant to evaluate the EMC performance of the product sample received on Dec. 06, 2010 would like to declare that the tested sample has been evaluated and found to be in compliance with the tested rule parts. The data recorded as well as the test configuration specified is true and accurate for showing the sample's EMC nature.

*Jordan Hsiao 2011.10.26*

Jordan Hsiao

SPORTON INTERNATIONAL INC.

## 2. SUMMARY OF THE TEST RESULT

Applied Standard: 47 CFR FCC Part 15 Subpart E				
Part	Rule Section	Description of Test	Result	Under Limit
4.1	15.207	AC Power Line Conducted Emissions	Complies	4.13 dB
4.2	15.407(a)	26dB Spectrum Bandwidth	Complies	-
4.3	15.407(a)	Maximum Conducted Output Power	Complies	0.14 dB
4.4	15.407(a)	Power Spectral Density	Complies	2.30 dB
4.5	15.407(a)	Peak Excursion	Complies	6.68 dB
4.6	15.407(b)	Radiated Emissions	Complies	0.17 dB
4.7	15.407(b)	Band Edge Emissions	Complies	0.03 dB
4.8	15.407(g)	Frequency Stability	Complies	-
4.9	15.203	Antenna Requirements	Complies	-

Test Items	Uncertainty	Remark
AC Power Line Conducted Emissions	±2.3dB	Confidence levels of 95%
Maximum Conducted Output Power	±0.5dB	Confidence levels of 95%
Power Spectral Density	±0.5dB	Confidence levels of 95%
Peak Excursion	±0.5dB	Confidence levels of 95%
26dB Spectrum Bandwidth / Frequency Stability	±8.5×10 <sup>-8</sup>	Confidence levels of 95%
Radiated Emissions (9kHz~30MHz)	±0.8dB	Confidence levels of 95%
Radiated Emissions (30MHz~1000MHz)	±1.9dB	Confidence levels of 95%
Radiated / Band Edge Emissions (1GHz~18GHz)	±1.9dB	Confidence levels of 95%
Radiated Emissions (18GHz~40GHz)	±1.9dB	Confidence levels of 95%
Temperature	±0.7°C	Confidence levels of 95%
Humidity	±3.2%	Confidence levels of 95%
DC / AC Power Source	±1.4%	Confidence levels of 95%

### 3. GENERAL INFORMATION

#### 3.1. Product Details

##### IEEE 802.11n

Items	Description
Product Type	WLAN (2TX, 2RX) / WLAN (1TX, 1RX)
Radio Type	Intentional Transceiver
Power Type	From Host System
Modulation	see the below table for IEEE 802.11n
Data Modulation	OFDM (BPSK / QPSK / 16QAM / 64QAM)
Data Rate (Mbps)	see the below table for IEEE 802.11n
Frequency Range	5150 ~ 5250MHz
Channel Number	19 for 20MHz bandwidth ; 9 for 40MHz bandwidth
Channel Band Width (99%)	MCS0 (20MHz): 18.24 MHz ; MCS0 (40MHz): 36.48 MHz
Conducted Output Power	MCS0 (20MHz): 16.81 dBm ; MCS0 (40MHz): 16.48 dBm
Carrier Frequencies	Please refer to section 3.4
Antenna	Please refer to section 3.3

##### IEEE 802.11a

Items	Description
Product Type	WLAN (2TX, 2RX) / WLAN (1TX, 1RX)
Radio Type	Intentional Transceiver
Power Type	From Host System
Modulation	OFDM for IEEE 802.11a
Data Modulation	OFDM (BPSK / QPSK / 16QAM / 64QAM)
Data Rate (Mbps)	OFDM (6/9/12/18/24/36/48/54)
Frequency Range	5150 ~ 5250MHz
Channel Number	19
Channel Band Width (99%)	17.76 MHz
Conducted Output Power	16.86 dBm
Carrier Frequencies	Please refer to section 3.4
Antenna	Please refer to section 3.3

**Antenna & Band width**

Antenna	Single (TX)		Two (TX)	
	20 MHz	40 MHz	20 MHz	40 MHz
IEEE 802.11a	V	X	V	X
IEEE 802.11n	V	V	V	V

**IEEE 802.11n spec**

MCS Index	Nss	Modulation	R	NBPS	NCBPS		NDBPS		Datarate(Mbps)			
					20MHz	40MHz	20MHz	40MHz	800nsGI		400nsGI	
									20MHz	40MHz	20MHz	40MHz
0	1	BPSK	1/2	1	52	108	26	54	6.5	13.5	7.200	15
1	1	QPSK	1/2	2	104	216	52	108	13.0	27.0	14.400	30
2	1	QPSK	3/4	2	104	216	78	162	19.5	40.5	21.700	45
3	1	16-QAM	1/2	4	208	432	104	216	26.0	54.0	28.900	60
4	1	16-QAM	3/4	4	208	432	156	324	39.0	81.0	43.300	90
5	1	64-QAM	2/3	6	312	648	208	432	52.0	108.0	57.800	120
6	1	64-QAM	3/4	6	312	648	234	486	58.5	121.5	65.000	135
7	1	64-QAM	5/6	6	312	648	260	540	65.0	135.0	72.200	150
8	2	BPSK	1/2	1	104	216	52	108	13.0	27.0	14.444	30
9	2	QPSK	1/2	2	208	432	104	216	26.0	54.0	28.889	60
10	2	QPSK	3/4	2	208	432	156	324	39.0	81.0	43.333	90
11	2	16-QAM	1/2	4	416	864	208	432	52.0	108.0	57.778	120
12	2	16-QAM	3/4	4	416	864	312	648	78.0	162.0	86.667	180
13	2	64-QAM	2/3	6	624	1296	416	864	104.0	216.0	115.556	240
14	2	64-QAM	3/4	6	624	1296	468	972	117.0	243.0	130.000	270
15	2	64-QAM	5/6	6	624	1296	520	1080	130.0	270.0	144.444	300

Symbol	Explanation
NSS	Number of spatial streams
R	Code rate
NBPS	Number of coded bits per single carrier
NCBPS	Number of coded bits per symbol
NDBPS	Number of data bits per symbol
GI	guard interval

### 3.2. Accessories

Power	Brand	P/N	Model	Rating
Adapter 1	PIE	332-10202-01	P030WE120B 1200-2LF	Input: 100-240VAC, 50/60Hz, 1.0A Output: 12VDC, 2.5A
Adapter 2	LEI	332-10102-01	MU30-5120250-C5	Input: 100-240VAC, 50/60Hz, 0.8A Output: 12VDC, 2.5A
Others				
RJ-45 Cable, Shielded, 150cm				
Adapter				

### 3.3. Table for Filed Antenna

Ant.	Brand	Model Name	Antenna Type	Connector	Gain (dBi)		Remark
					2.4GHz Band	5GHz Band	
1(J21)	FOXCONN	FX01A21-0G-EF	PCB Antenna	U.FL	3.45	-	TX/RX
2(J20)	FOXCONN	FX01A18-0G-EF	PCB Antenna	U.FL	3.48	-	TX/RX
3(J1101)	FOXCONN	81.EZY15.G11	PCB Antenna	U.FL	-	5.00	TX/RX
4(J1100)	FOXCONN	81.EZY15.G11	PCB Antenna	U.FL	-	5.00	TX/RX

Note: There are four sets of antenna provided to this EUT and all of them can be used as transmitting and receiving antenna, two of them are used for 2.4GHz Band and the others are used for 5GHz Band.

**IEEE 802.11n mode (2TX/2RX):**

Ant. 3 and Ant. 4 could transmit/receive simultaneously.

**IEEE 802.11n mode (1TX/1RX):**

Only Ant. 3 can be used as transmitting/receiving antenna.

**IEEE 802.11a mode (1TX/1RX):**

Only Ant. 4 can be used as transmitting/receiving antenna.

**IEEE 802.11a mode (1TX/1RX):**

Both Ant. 3 and Ant. 4 can be used as transmitting/receiving antennas.

But only one antenna could transmit/receive at the same time.

The EUT supports the antenna with TX/RX diversity function.

Add test result of Ant. 3 was tested and recorded in the report.



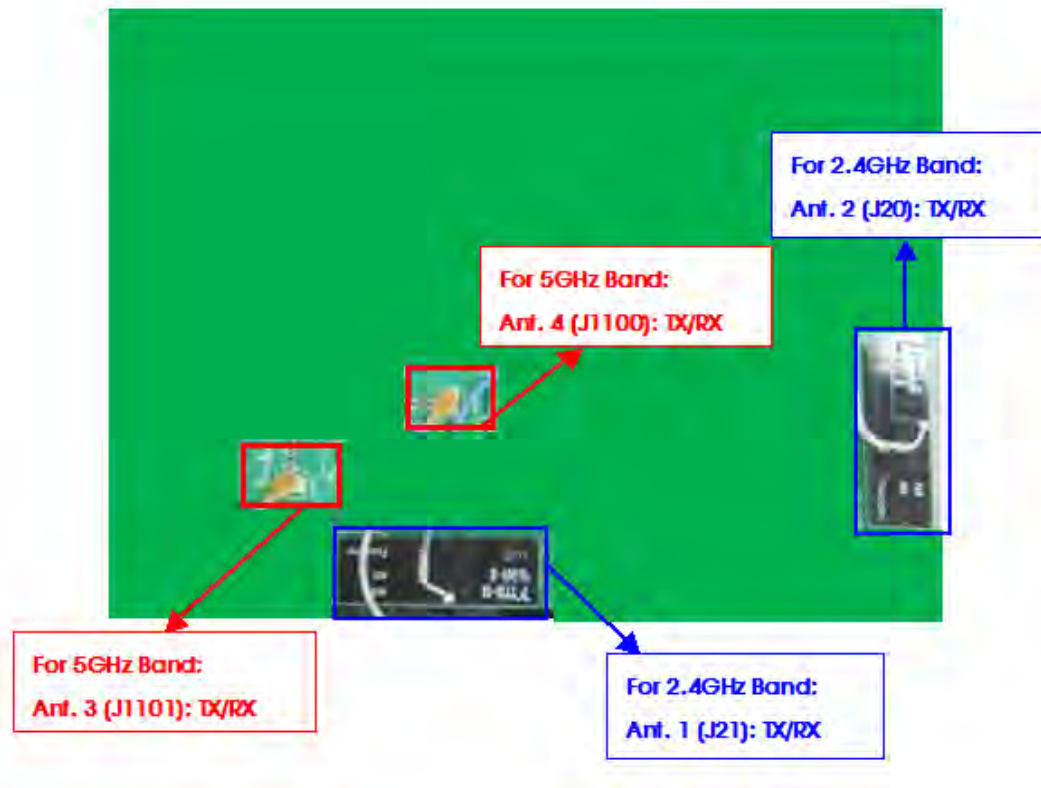

### 3.4. Table for Carrier Frequencies

For IEEE 802.11a, use Channel 36, 40, 44, 48.

There are two bandwidth systems for IEEE 802.11n.

For both 20MHz bandwidth systems, use Channel 36, 40, 44, 48.

For both 40MHz bandwidth systems, use Channel 38, 46.

Frequency Band	Channel No.	Frequency	Channel No.	Frequency
5150~5250 MHz Band 1	36	5180 MHz	44	5220 MHz
	38	5190 MHz	46	5230 MHz
	40	5200 MHz	48	5240 MHz

### 3.5. Table for Test Modes

Preliminary tests were performed in different data rate to find the worst radiated emission. The data rate shown in the table below is the worst-case rate with respect to the specific test item. Investigation has been done on all the possible configurations for searching the worst cases. The following table is a list of the test modes shown in this test report.

Test Items	Mode		Data Rate	Channel	Antenna
AC Power Conducted Emission	Normal Link		Auto	-	-
Max. Conducted Output Power Power Spectral Density	MCS0/20MHz	Band 1	6.5Mbps	36/40/48	3, 3/4/3+4
	MCS0/40MHz	Band 1	13.5Mbps	38/46	3, 3/4/3+4
	11a/BPSK	Band 1	6Mbps	36/40/48	3, 4
26dB Spectrum Bandwidth 99% Occupied Bandwidth Measurement Peak Excursion	MCS0/20MHz	Band 1	6.5Mbps	36/40/48	3, 3+4
	MCS0/40MHz	Band 1	13.5Mbps	38/46	3, 3+4
	11a/BPSK	Band 1	6Mbps	36/40/48	3, 4
Radiated Emission Below 1GHz	Normal Link		Auto	-	-
Radiated Emission Above 1GHz	MCS0/20MHz	Band 1	6.5Mbps	36/40/48	3, 3+4
	MCS0/40MHz	Band 1	13.5Mbps	38/46	3, 3+4
	11a/BPSK	Band 1	6Mbps	36/40/48	3, 4
Band Edge Emission	MCS0/20MHz	Band 1	6.5Mbps	36/40/48	3, 3+4
	MCS0/40MHz	Band 1	13.5Mbps	38/46	3, 3+4
	11a/BPSK	Band 1	6Mbps	36/40/48	3, 4
Frequency Stability	Un-modulation		-	40/60	N/A

NOTE: All the test modes were listed as below.

Test Mode 1: EUT put vertically on the table + Adapter 1

Test Mode 2: EUT put horizontally on the table + Adapter 1

Test Mode 3: EUT put vertically on the table + Adapter 2

Test Mode 4: EUT put horizontally on the table + Adapter 2

**<For Conducted Emissions Test>:**

Due to Mode 3 generated the worst test result, so it was recorded in this report.

**<For Radiated Emissions Test Below 1GHz>:**

Due to Mode 2 generated the worst test result, so it was recorded in this report.

**<For Radiated Emissions Test Above 1GHz>:**

Due to Mode 1 generated the worst test result, so it was recorded in this report.

### 3.6. Table for Testing Locations

Test Site No.	Site Category	Location	FCC Reg. No.	IC File No.	VCCI Reg. No
03CH01-CB	SAC	Hsin Chu	262045	IC 4086D	-
CO01-CB	Conduction	Hsin Chu	262045	IC 4086D	-
TH01-CB	OVEN Room	Hsin Chu	-	-	-

Open Area Test Site (OATS); Semi Anechoic Chamber (SAC); Fully Anechoic Chamber (FAC).

Please refer section 6 for Test Site Address.

### 3.7. Table for Class II Change

This product is an extension of original one reported under Sporton project number: 0D1643-02

Below is the table for the change of the product with respect to the original one.

Modifications	Performance Checking
<b>For IEEE 802.11a:</b> 1. Add 1TX/1RX function for Ant. 3 for Band 1.  <b>For IEEE 802.11n:</b> 1. Add 1TX/1RX function for Ant. 3 for Band 1.	Max. Peak Conducted Output Power Power Spectral Density 6dB Spectrum Bandwidth Radiated Emissions above 1GHz Band Edge Emissions

### 3.8. Table for Supporting Units

Support Unit	Brand	Model	FCC ID
Notebook	DELL	PP25L	E2K4965AGNM
Notebook	DELL	M1330	E2K4965AGNM
Notebook	DELL	D420	E2KWM3945ABG
Mouse	First Price	FP-M02	DoC
Modem	ACEEX	DM1414	IFAXDM1414
Flash Disk	Silicon	I-Series	DoC

### 3.9. Table for Parameters of Test Software Setting

During testing, Channel & Power Controlling Software provided by the customer was used to control the operating channel as well as the output power level. The RF output power selection is for the setting of RF output power expected by the customer and is going to be fixed on the firmware of the final end product.

#### Power Parameters of IEEE 802.11n MCS0 20MHz (2TX/2RX) / Ant. 3 + Ant. 4:

Test Software Version	DOS		
Frequency	5180 MHz	5200 MHz	5240 MHz
MCS0 20MHz	56	56	56

#### Power Parameters of IEEE 802.11n MCS0 40MHz (2TX/2RX) / Ant. 3 + Ant. 4:

Test Software Version	DOS	
Frequency	5190 MHz	5230 MHz
MCS0 40MHz	51	56

#### Power Parameters of IEEE 802.11n MCS0 20MHz (1TX/1RX) / Ant. 3:

Test Software Version	DOS		
Frequency	5180 MHz	5200 MHz	5240 MHz
MCS0 20MHz	66	66	66

#### Power Parameters of IEEE 802.11n MCS0 40MHz (1TX/1RX) / Ant. 3:

Test Software Version	DOS	
Frequency	5190 MHz	5230 MHz
MCS0 40MHz	52	66

#### Power Parameters of IEEE 802.11a (1TX/1RX) / Ant. 4:

Test Software Version	DOS		
Frequency	5180 MHz	5200 MHz	5240 MHz
OFDM	68	68	68

#### Power Parameters of IEEE 802.11a (1TX/1RX) / Ant. 3:

Test Software Version	DOS		
Frequency	5180 MHz	5200 MHz	5240 MHz
OFDM	66	66	66

During the test, "DOS" under WIN XP was executed the test program to control the EUT continuously transmit RF signal.

### 3.10. Test Configurations

#### 3.10.1. Radiation Emissions Test Configuration

Test Configuration: 9KHz~1GHz

Test Mode: Mode 2

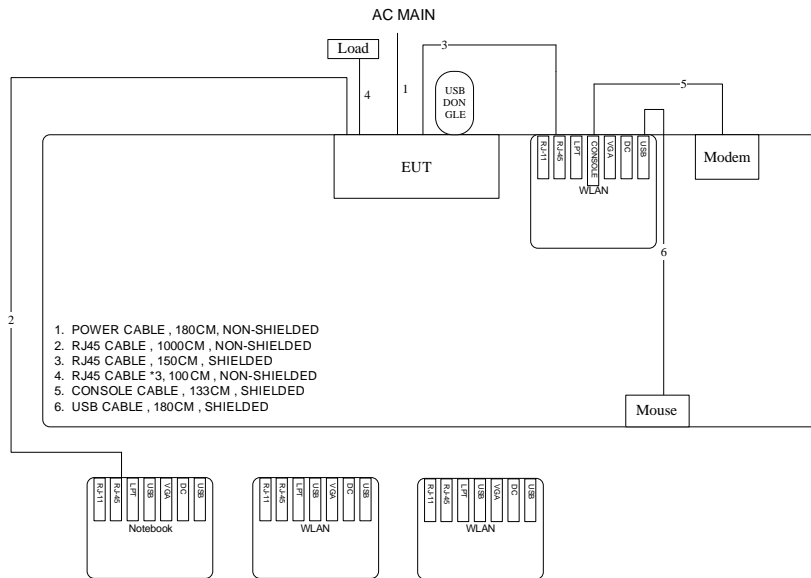

Test Configuration: Above 1GHz

Test Mode: Mode 1

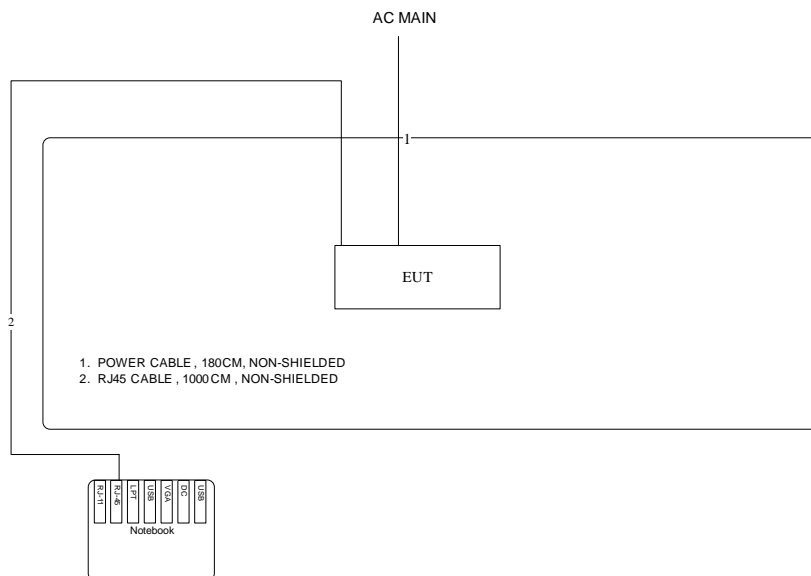

### 3.10.2. AC Power Line Conduction Emissions Test Configuration

Test Mode: Mode 3

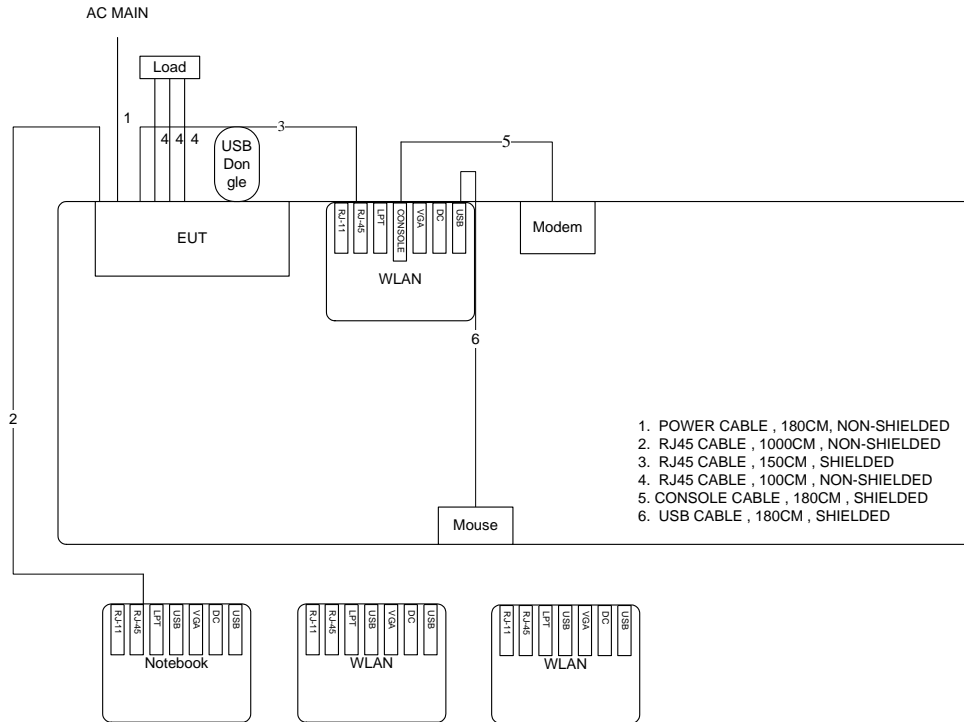

## 4. TEST RESULT

### 4.1. AC Power Line Conducted Emissions Measurement

#### 4.1.1. Limit

For this product that is designed to connect to the AC power line, the radio frequency voltage that is conducted back onto the AC power line on any frequency or frequencies within the band 150 kHz to 30 MHz shall not exceed below limits table.

Frequency (MHz)	QP Limit (dBuV)	AV Limit (dBuV)
0.15~0.5	66~56	56~46
0.5~5	56	46
5~30	60	50

#### 4.1.2. Measuring Instruments and Setting

Please refer to section 5 of equipments list in this report. The following table is the setting of the receiver.

Receiver Parameters	Setting
Attenuation	10 dB
Start Frequency	0.15 MHz
Stop Frequency	30 MHz
IF Bandwidth	9 KHz

#### 4.1.3. Test Procedures

1. Configure the EUT according to ANSI C63.10. The EUT or host of EUT has to be placed 0.4 meter far from the conducting wall of the shielding room and at least 80 centimeters from any other grounded conducting surface.
2. Connect EUT or host of EUT to the power mains through a line impedance stabilization network (LISN).
3. All the support units are connected to the other LISNs. The LISN should provide 50uH/50ohms coupling impedance.
4. The frequency range from 150 KHz to 30 MHz was searched.
5. Set the test-receiver system to Peak Detect Function and Specified Bandwidth with Maximum Hold Mode.
6. The measurement has to be done between each power line and ground at the power terminal.

#### 4.1.4. Test Setup Layout

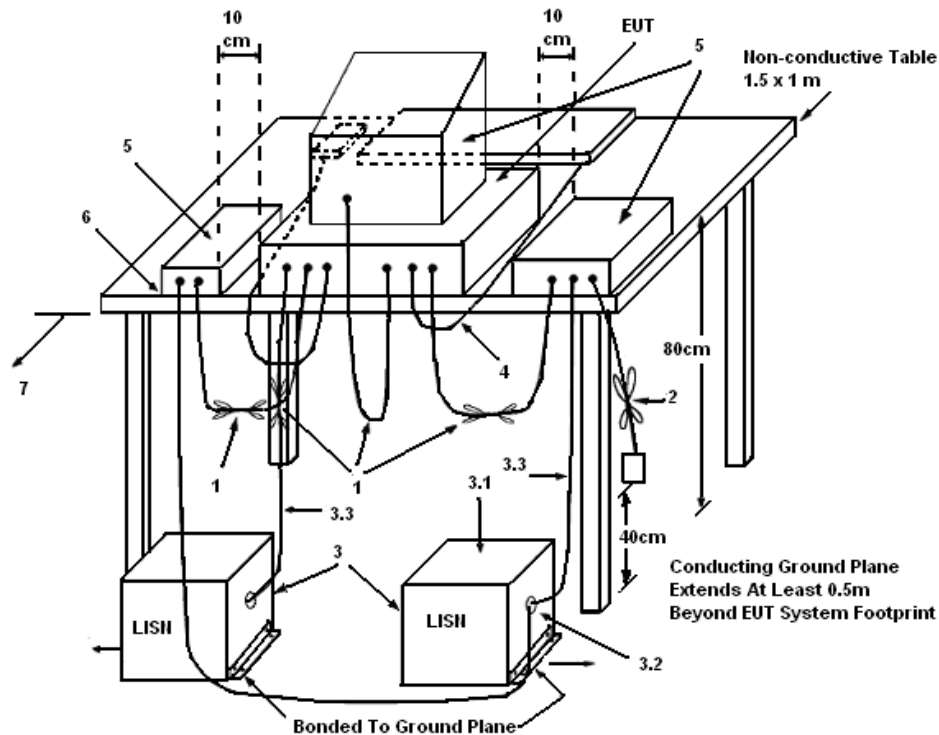

#### LEGEND:

- (1) Interconnecting cables that hang closer than 40 cm to the ground plane shall be folded back and forth in the center forming a bundle 30 to 40 cm long.
- (2) I/O cables that are not connected to a peripheral shall be bundled in the center. The end of the cable may be terminated, if required, using the correct terminating impedance. The overall length shall not exceed 1 m.
- (3) EUT connected to one LISN. Unused LISN measuring port connectors shall be terminated in 50  $\Omega$ . LISN can be placed on top of, or immediately beneath, reference ground plane.
  - (3.1) All other equipment powered from additional LISN(s).
  - (3.2) Multiple outlet strip can be used for multiple power cords of non-EUT equipment.
  - (3.3) LISN at least 80 cm from nearest part of EUT chassis.
- (4) Cables of hand-operated devices, such as keyboards, mice, etc., shall be placed as for normal use.
- (5) Non-EUT components of EUT system being tested.
- (6) Rear of EUT, including peripherals, shall all be aligned and flush with rear of tabletop.
- (7) Rear of tabletop shall be 40 cm removed from a vertical conducting plane that is bonded to the ground plane.

#### 4.1.5. Test Deviation

There is no deviation with the original standard.

#### 4.1.6. EUT Operation during Test

The EUT was placed on the test table and programmed in normal function.



4.1.7. Results of AC Power Line Conducted Emissions Measurement

Temperature	23°C	Humidity	54%
Test Engineer	Ryo Fan	Phase	Line
Configuration	Normal Link / Mode 3		

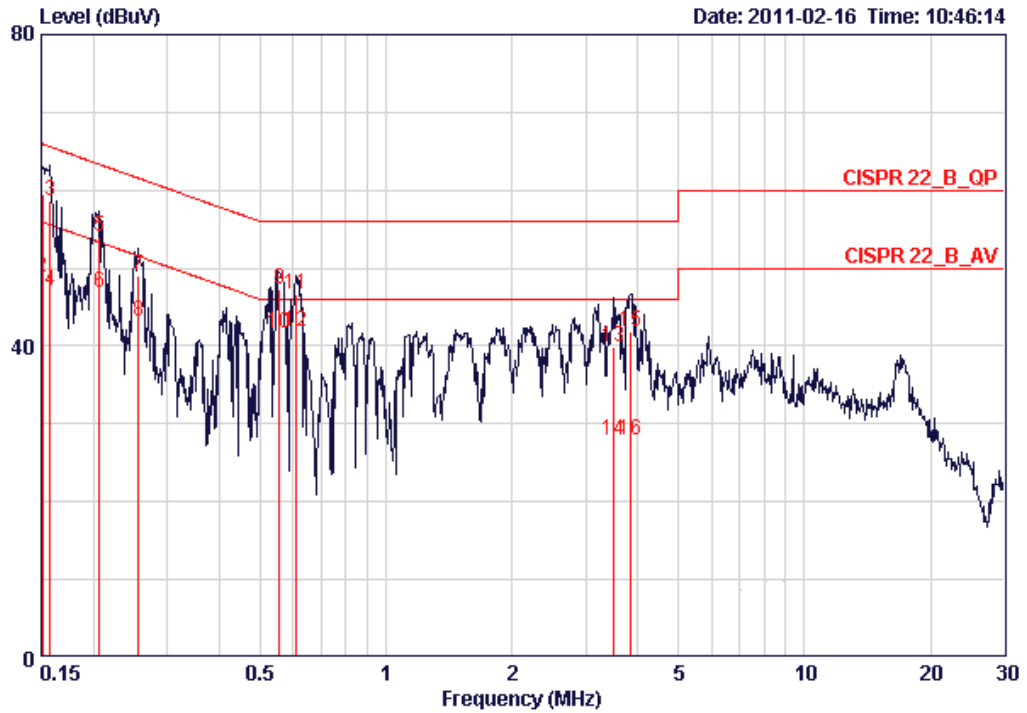

	Freq	Level	Over Limit	Limit Line	Read Level	LISN Factor	Cable Loss	Remark
	MHz	dBuV	dB	dBuV	dBuV	dB	dB	
1	0.15080	59.46	-6.49	65.96	59.19	0.07	0.20	QP
2	0.15080	48.72	-7.23	55.96	48.45	0.07	0.20	AVERAGE
3	0.15733	58.61	-6.99	65.60	58.34	0.07	0.20	QP
4	0.15733	47.11	-8.49	55.60	46.84	0.07	0.20	AVERAGE
5	0.20614	53.97	-9.39	63.36	53.72	0.05	0.20	QP
6	0.20614	46.78	-6.58	53.36	46.53	0.05	0.20	AVERAGE
7	0.25615	49.00	-12.55	61.56	48.76	0.04	0.20	QP
8	0.25615	43.12	-8.43	51.56	42.88	0.04	0.20	AVERAGE
9	0.55726	47.35	-8.65	56.00	47.12	0.03	0.20	QP
10	0.55726	41.62	-4.38	46.00	41.39	0.03	0.20	AVERAGE
11	0.61075	46.74	-9.26	56.00	46.51	0.03	0.20	QP
12	0.61075	41.87	-4.13	46.00	41.64	0.03	0.20	AVERAGE
13	3.509	39.94	-16.06	56.00	39.55	0.09	0.30	QP
14	3.509	27.95	-18.05	46.00	27.56	0.09	0.30	AVERAGE
15	3.840	41.81	-14.19	56.00	41.41	0.10	0.30	QP
16	3.840	27.94	-18.06	46.00	27.54	0.10	0.30	AVERAGE

Temperature	23°C	Humidity	54%
Test Engineer	Ryo Fan	Phase	Neutral
Configuration	Normal Link / Mode 3		

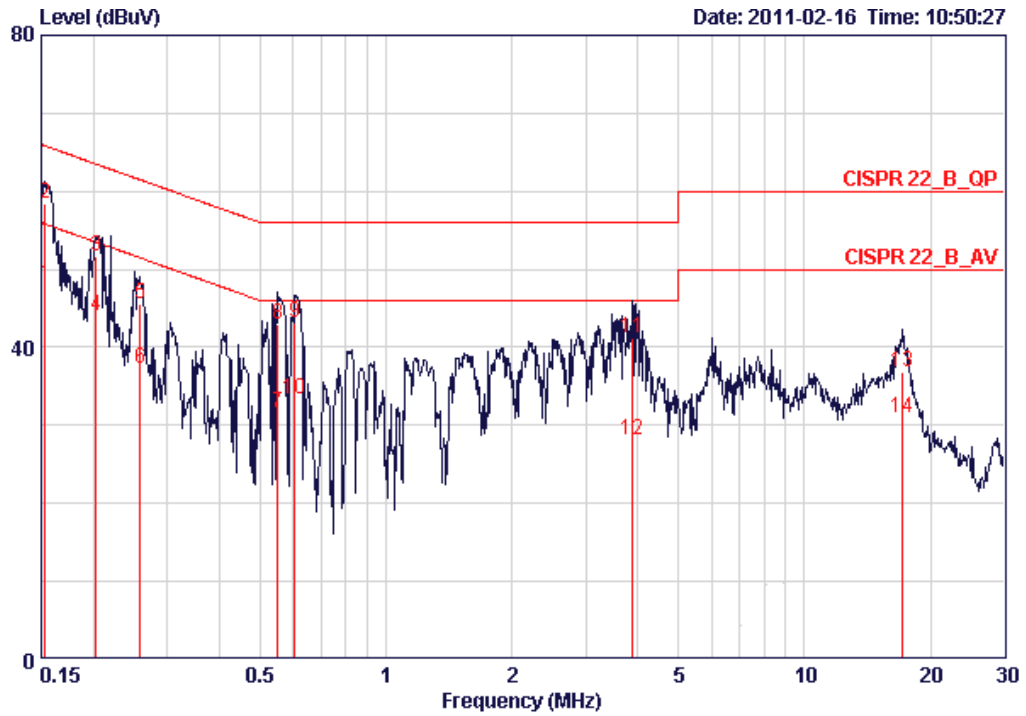

	Freq	Level	Over Limit	Limit Line	Read Level	LISN Factor	Cable Loss	Remark
	MHz	dBuV	dB	dBuV	dBuV	dB	dB	
1	0.15321	47.94	-7.88	55.82	47.64	0.10	0.20	AVERAGE
2	0.15321	58.46	-7.36	65.82	58.16	0.10	0.20	QP
3	0.20289	51.59	-11.90	63.49	51.31	0.08	0.20	QP
4	0.20289	44.01	-9.48	53.49	43.73	0.08	0.20	AVERAGE
5	0.25888	45.52	-15.95	61.47	45.24	0.08	0.20	QP
6	0.25888	37.22	-14.25	51.47	36.94	0.08	0.20	AVERAGE
7	0.55226	31.69	-14.31	46.00	31.42	0.07	0.20	AVERAGE
8	0.55226	42.92	-13.08	56.00	42.65	0.07	0.20	QP
9	0.60431	43.22	-12.78	56.00	42.95	0.07	0.20	QP
10	0.60431	33.46	-12.54	46.00	33.19	0.07	0.20	AVERAGE
11	3.881	41.21	-14.79	56.00	40.77	0.14	0.30	QP
12	3.881	28.08	-17.92	46.00	27.64	0.14	0.30	AVERAGE
13	17.199	36.75	-23.26	60.00	35.56	0.69	0.50	QP
14	17.199	31.02	-18.99	50.00	29.83	0.69	0.50	AVERAGE

Note: Level = Read Level + LISN Factor + Cable Loss.

## 4.2. 99% Occupied Bandwidth Measurement

### 4.2.1. Limit

No restriction limits. But resolution bandwidth within band edge measurement is 1% of the 99% occupied bandwidth.

### 4.2.2. Measuring Instruments and Setting

Please refer to section 5 of equipments list in this report. The following table is the setting of the spectrum analyzer.

Spectrum Parameters	Setting
Attenuation	Auto
Span Frequency	> 26dB Bandwidth
RB	300 kHz
VB	1000 kHz
Detector	Peak
Trace	Max Hold
Sweep Time	Auto

### 4.2.3. Test Procedures

1. The transmitter output (antenna port) was connected to the spectrum analyzer in peak hold mode.
2. The resolution bandwidth of 300 kHz and the video bandwidth of 1000 kHz were used.
3. Measured the spectrum width with power higher than 26dB below carrier.

### 4.2.4. Test Setup Layout

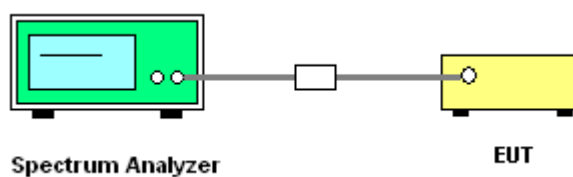

### 4.2.5. Test Deviation

There is no deviation with the original standard.

### 4.2.6. EUT Operation during Test

The EUT was programmed to be in continuously transmitting mode.

#### 4.2.7. Test Result of 99% Occupied Bandwidth

<b>Temperature</b>	23°C	<b>Humidity</b>	60%
<b>Test Engineer</b>	Allen Liu	<b>Configurations</b>	IEEE 802.11n (2TX/2RX)

##### Configuration IEEE 802.11n MCS0 20MHz / Ant. 3 + Ant. 4

Channel	Frequency	26dB Bandwidth (MHz)	99% Occupied Bandwidth (MHz)
36	5180 MHz	23.84	16.80
40	5200 MHz	25.92	17.76
48	5240 MHz	25.92	17.92

##### Configuration IEEE 802.11n MCS0 40MHz / Ant. 3 + Ant. 4

Channel	Frequency	26dB Bandwidth (MHz)	99% Occupied Bandwidth (MHz)
38	5190 MHz	45.44	36.32
46	5230 MHz	45.60	36.32

<b>Temperature</b>	23°C	<b>Humidity</b>	60%
<b>Test Engineer</b>	Sean Ku	<b>Configurations</b>	IEEE 802.11n (1TX/1RX)

**Configuration IEEE 802.11n MCS0 20MHz / Ant. 3**

Channel	Frequency	26dB Bandwidth (MHz)	99% Occupied Bandwidth (MHz)
36	5180 MHz	28.16	18.24
40	5200 MHz	27.84	18.24
48	5240 MHz	29.60	18.24

**Configuration IEEE 802.11n MCS0 40MHz / Ant. 3**

Channel	Frequency	26dB Bandwidth (MHz)	99% Occupied Bandwidth (MHz)
38	5190 MHz	45.44	36.48
46	5230 MHz	46.72	36.48



<b>Temperature</b>	23°C	<b>Humidity</b>	60%
<b>Test Engineer</b>	Allen Liu	<b>Configurations</b>	IEEE 802.11a (1TX/1RX)

**Configuration IEEE 802.11a / Ant. 4**

<b>Channel</b>	<b>Frequency</b>	<b>26dB Bandwidth (MHz)</b>	<b>99% Occupied Bandwidth (MHz)</b>
36	5180 MHz	31.68	17.76
40	5200 MHz	28.00	17.60
48	5240 MHz	29.44	17.60



<b>Temperature</b>	23°C	<b>Humidity</b>	60%
<b>Test Engineer</b>	Sean Ku	<b>Configurations</b>	IEEE 802.11a (1TX/1RX)

**Configuration IEEE 802.11a / Ant. 3**

<b>Channel</b>	<b>Frequency</b>	<b>26dB Bandwidth (MHz)</b>	<b>99% Occupied Bandwidth (MHz)</b>
36	5180 MHz	28.96	17.44
40	5200 MHz	27.68	17.44
48	5240 MHz	28.48	17.44

<IEEE 802.11n (2TX/2RX)>

26 dB Bandwidth Plot on Configuration IEEE 802.11n MCS0 20MHz / Ant. 3 + Ant. 4 / 5180 MHz

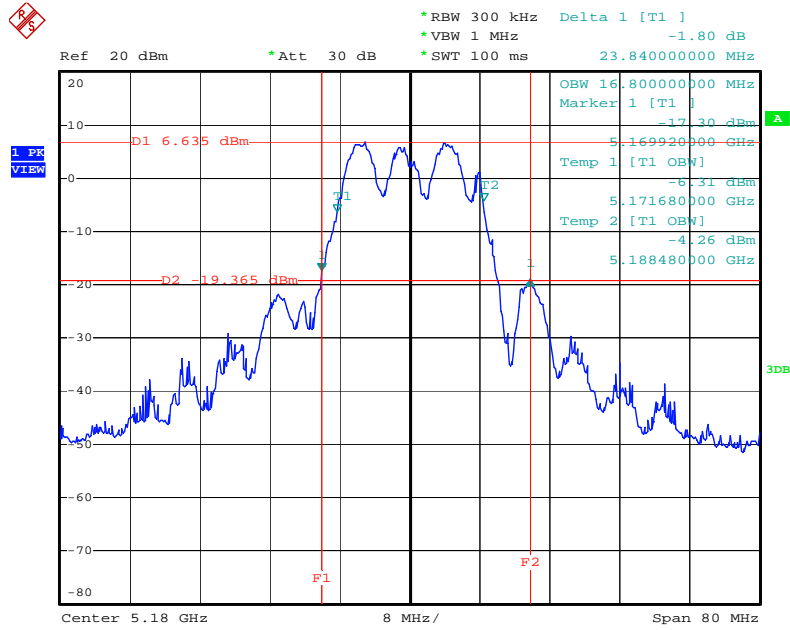

Date: 31.MAY.2011 08:46:32

26 dB Bandwidth Plot on Configuration IEEE 802.11n MCS0 20MHz / Ant. 3 + Ant. 4 / 5200 MHz

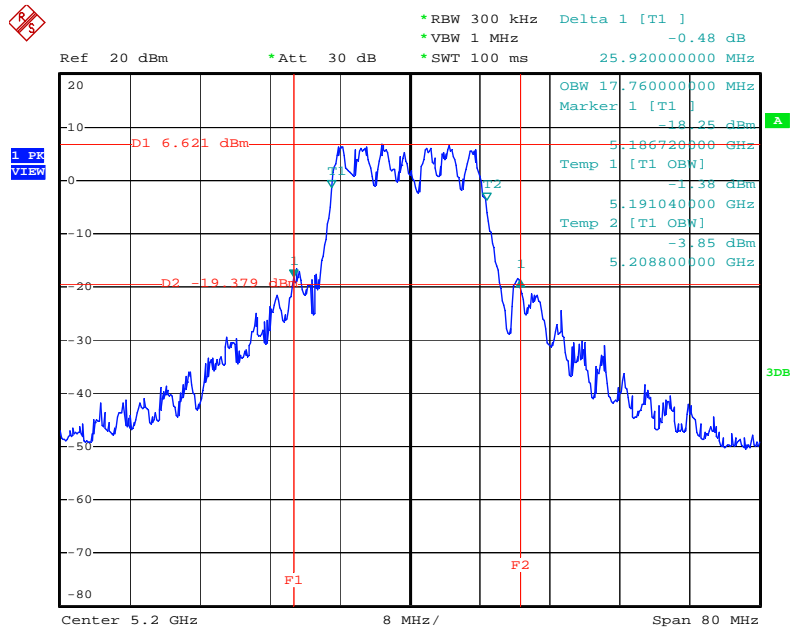

Date: 31.MAY.2011 08:48:14



26 dB Bandwidth Plot on Configuration IEEE 802.11n MCS0 20MHz / Ant. 3 + Ant. 4 / 5240 MHz

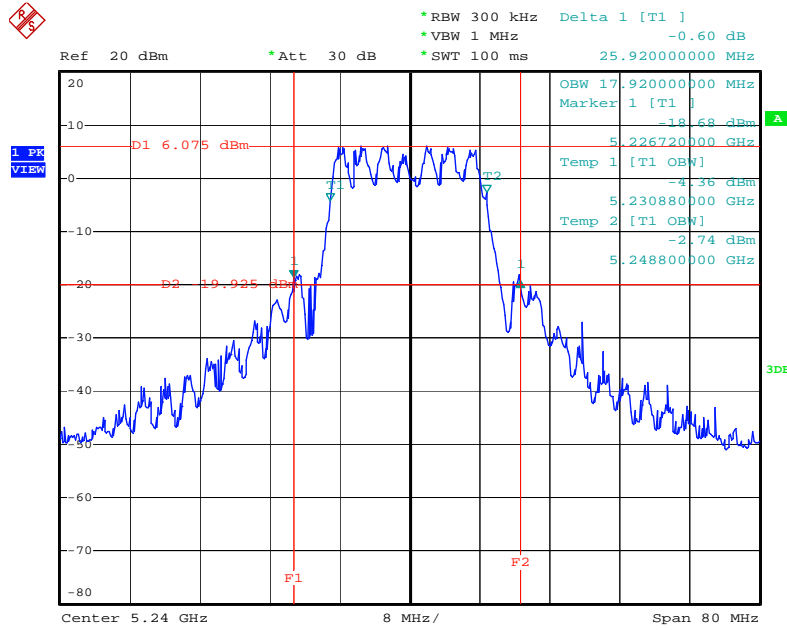

Date: 31.MAY.2011 09:00:13

26 dB Bandwidth Plot on Configuration IEEE 802.11n MCS0 40MHz / Ant. 3 + Ant. 4 / 5190 MHz

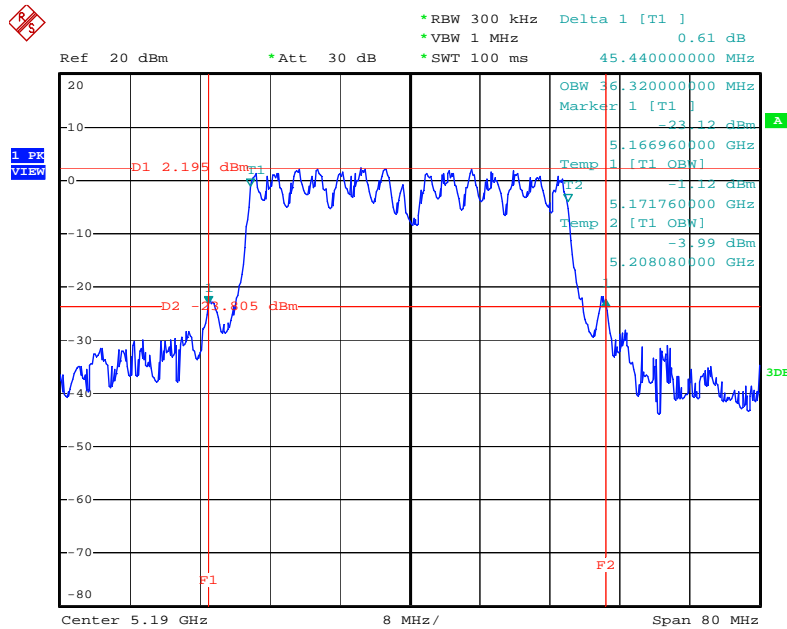

Date: 31.MAY.2011 09:27:04

26 dB Bandwidth Plot on Configuration IEEE 802.11n MCS0 40MHz / Ant. 3 + Ant. 4 / 5230 MHz

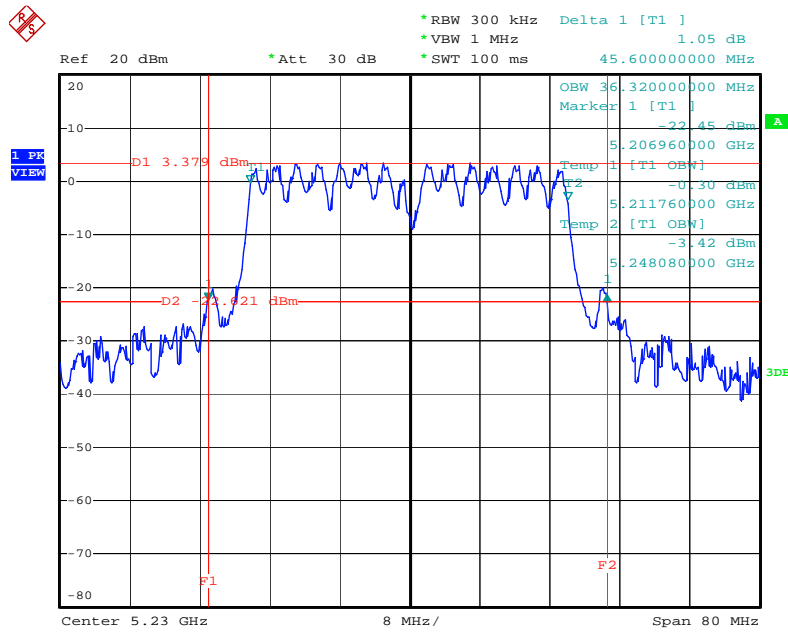

Date: 31.MAY.2011 09:28:25

<IEEE 802.11n (1TX/1RX)>

26 dB Bandwidth Plot on Configuration IEEE 802.11n MCS0 20MHz / Ant. 3 / 5180 MHz

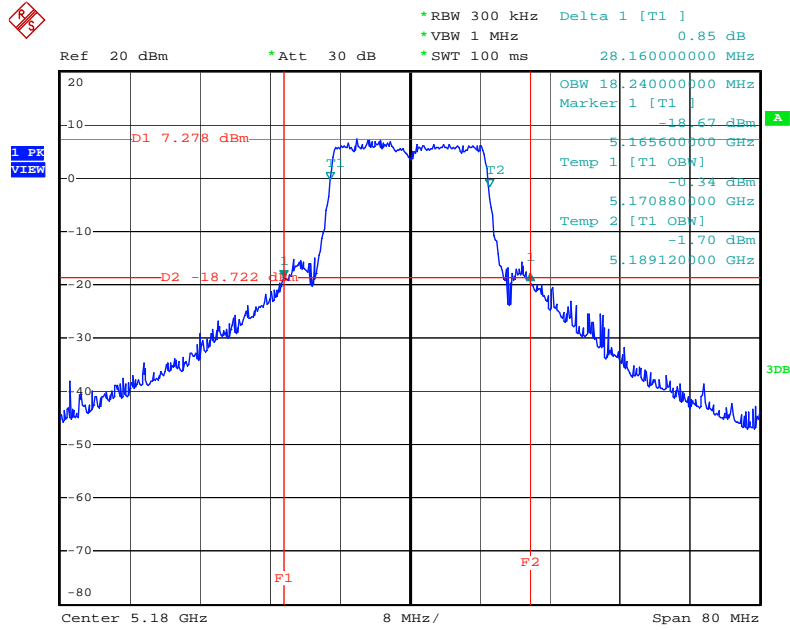

Date: 4.OCT.2011 03:57:22

26 dB Bandwidth Plot on Configuration IEEE 802.11n MCS0 20MHz / Ant. 3 / 5200 MHz

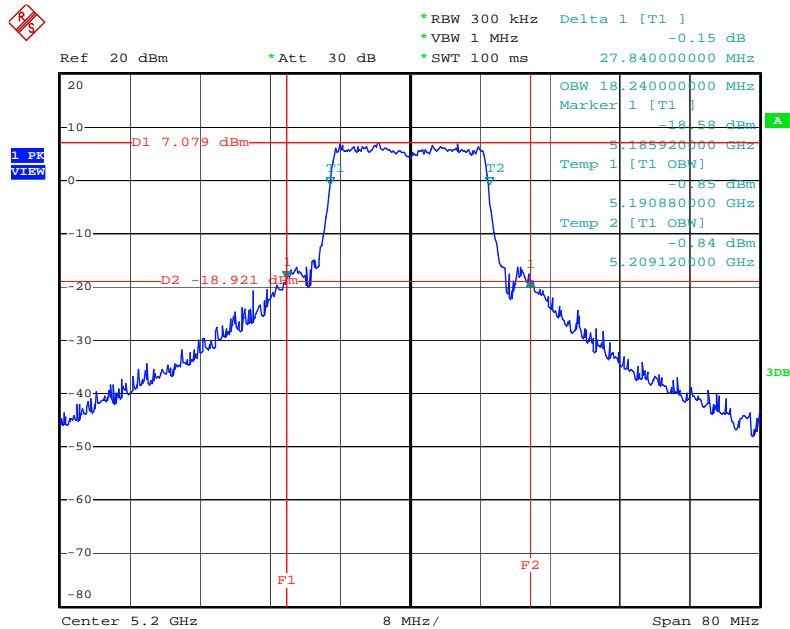

Date: 4.OCT.2011 04:01:09

26 dB Bandwidth Plot on Configuration IEEE 802.11n MCS0 20MHz / Ant. 3 / 5240 MHz

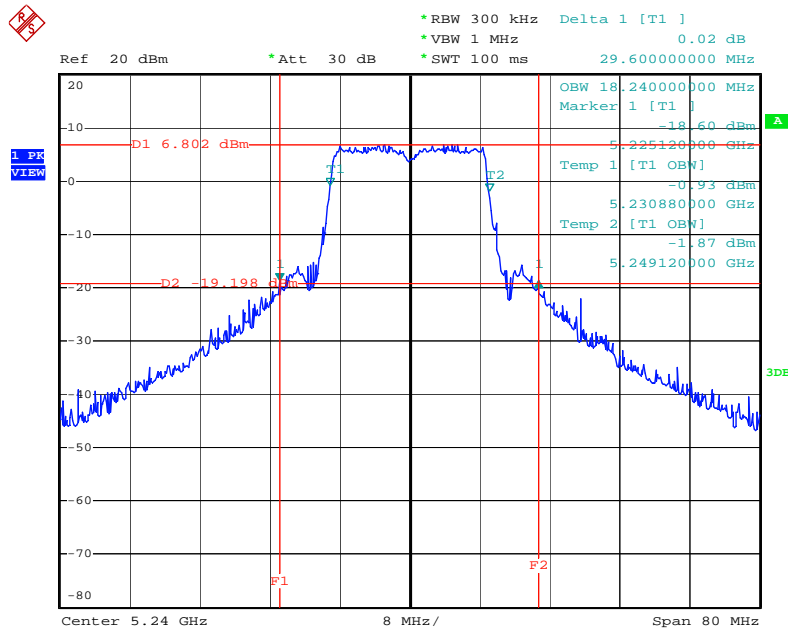

Date: 4.OCT.2011 04:02:25

26 dB Bandwidth Plot on Configuration IEEE 802.11n MCS0 40MHz / Ant. 3 / 5190 MHz

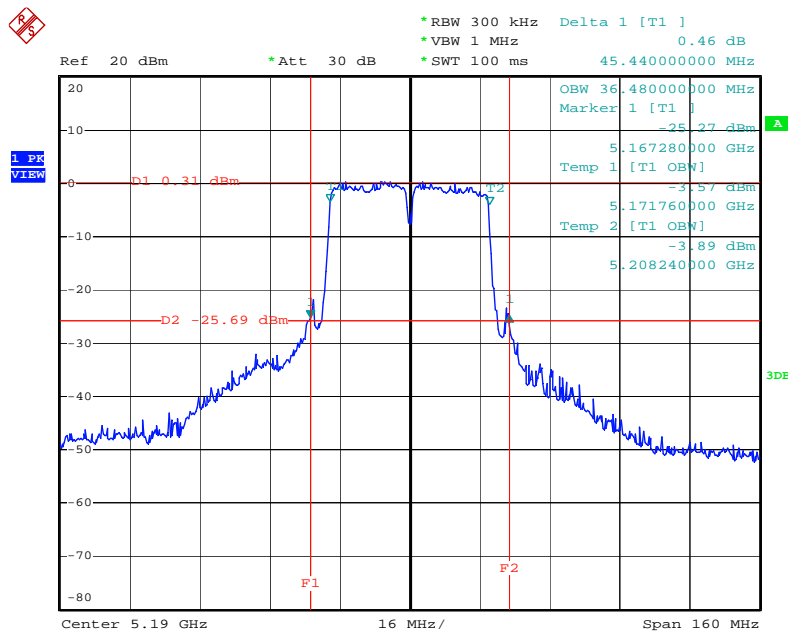

Date: 4.OCT.2011 04:04:14

26 dB Bandwidth Plot on Configuration IEEE 802.11n MCS0 40MHz / Ant. 3 / 5230 MHz

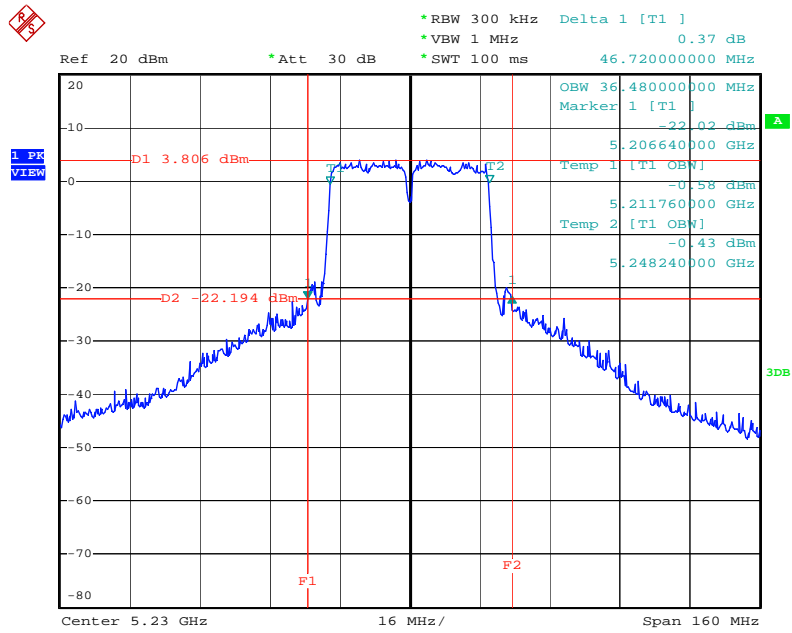

Date: 4.OCT.2011 04:05:38

<IEEE 802.11a (1TX/1RX)>

26 dB Bandwidth Plot on Configuration IEEE 802.11a / Ant. 4 / 5180 MHz

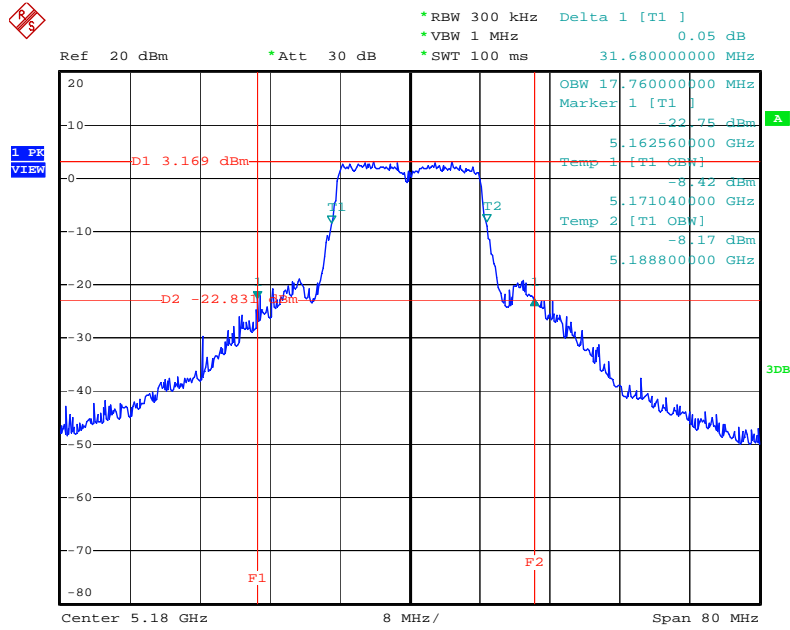

Date: 31.MAY.2011 07:53:04

26 dB Bandwidth Plot on Configuration IEEE 802.11a / Ant. 4 / 5200 MHz

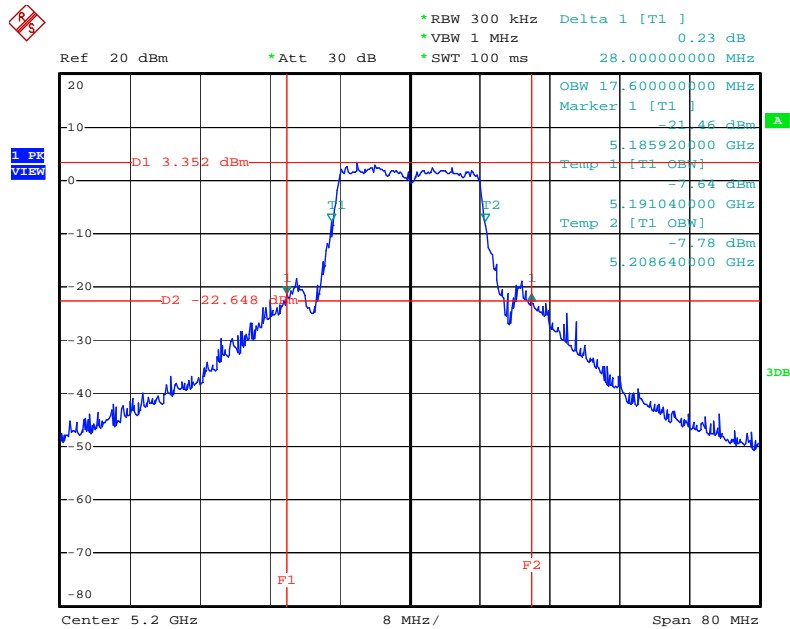

Date: 31.MAY.2011 07:54:17

26 dB Bandwidth Plot on Configuration IEEE 802.11a / Ant. 4 / 5240 MHz

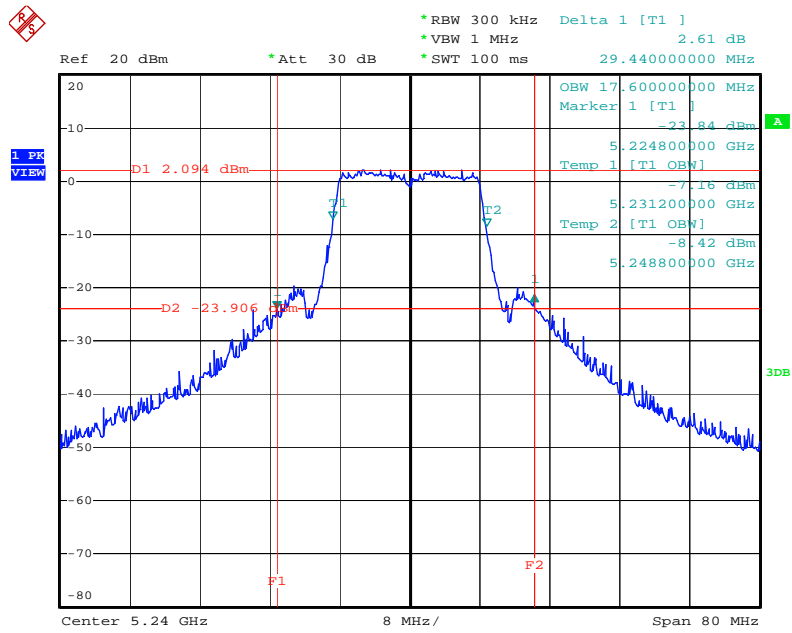

Date: 31.MAY.2011 07:56:43

<IEEE 802.11a (1TX/1RX)>

26 dB Bandwidth Plot on Configuration IEEE 802.11a / Ant. 3 / 5180 MHz

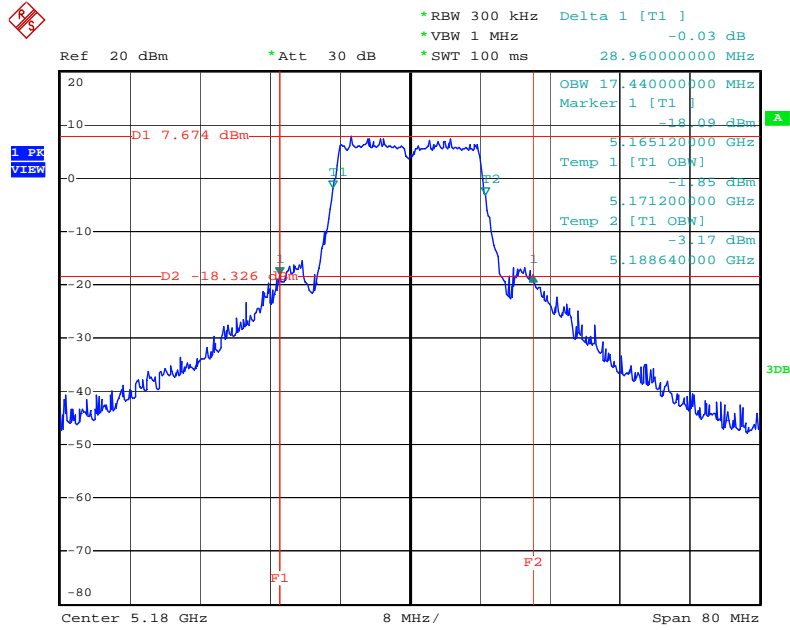

Date: 4.OCT.2011 03:53:09

26 dB Bandwidth Plot on Configuration IEEE 802.11a / Ant. 3 / 5200 MHz

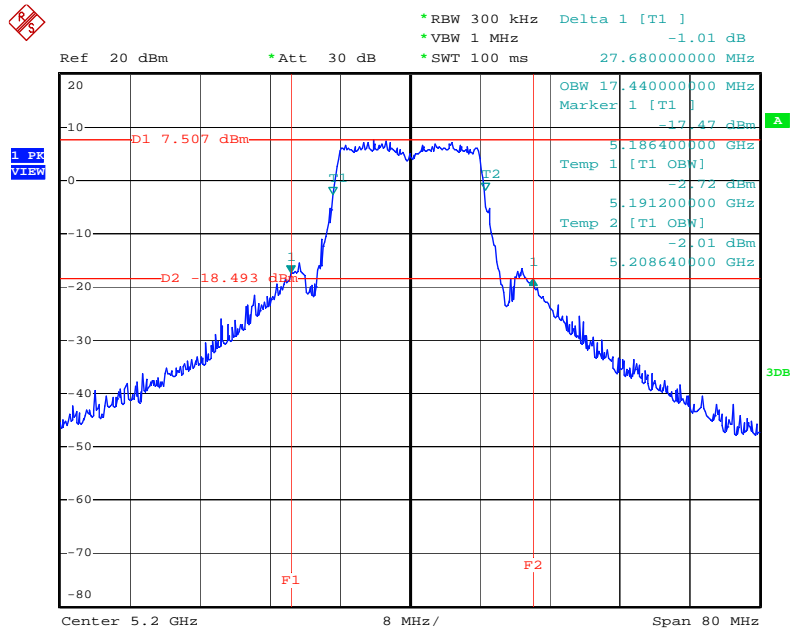

Date: 4.OCT.2011 03:54:28



26 dB Bandwidth Plot on Configuration IEEE 802.11a / Ant. 3 / 5240 MHz

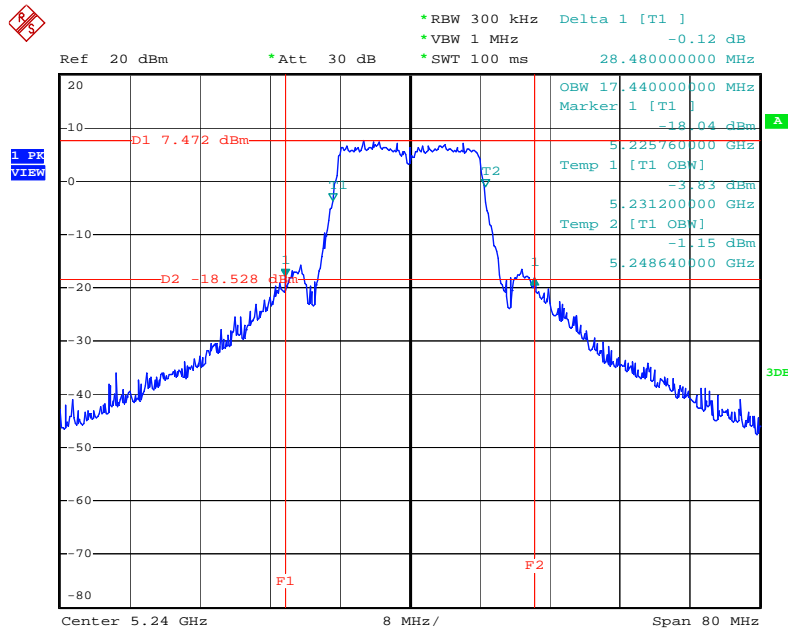

Date: 4.OCT.2011 03:55:41

### 4.3. Maximum Conducted Output Power Measurement

#### 4.3.1. Limit

For the band 5.15~5.25 GHz, the maximum conducted output power over the frequency band of operation shall not exceed the lesser of 50 mW (17dBm) or  $4 \text{ dBm} + 10\log B$ , where B is the 26 dB emissions bandwidth in MHz. If transmitting antennas of directional gain greater than 6 dBi are used, both the maximum conducted output power and the peak power spectral density shall be reduced by the amount in dB that the directional gain of the antenna exceeds 6 dBi.

For the 5.25-5.35 GHz and 5.470-5.725 GHz bands, the maximum conducted output power over the frequency bands of operation shall not exceed the lesser of 250 mW (24dBm) or  $11 \text{ dBm} + 10\log B$ , where B is the 26-dB emission bandwidth in MHz. If transmitting antennas of directional gain greater than 6 dBi are used, both the maximum conducted output power and the peak power spectral density shall be reduced by the amount in dB that the directional gain of the antenna exceeds 6 dBi.

For the band 5.725~5.825 GHz, the maximum conducted output power over the frequency band of operation shall not exceed the lesser of 1 W or  $17 \text{ dBm} + 10 \log B$ , where B is the 26-dB emission bandwidth in MHz. In addition, the peak power spectral density shall not exceed 17 dBm in any 1 MHz band. If transmitting antennas of directional gain greater than 6 dBi are used, both the maximum conducted output power and the peak power spectral density shall be reduced by the amount in dB that the directional gain of the antenna exceeds 6 dBi. However, fixed point-to-point U-NII devices operating in this band may employ transmitting antennas with directional gain up to 23 dBi without any corresponding reduction in the transmitter peak output power or peak power spectral density. For fixed, point-to-point U-NII transmitters that employ a directional antenna gain greater than 23 dBi, a 1 dB reduction in peak transmitter power and peak power spectral density for each 1 dB of antenna gain in excess of 23 dBi would be required.

#### 4.3.2. Measuring Instruments and Setting

The following table is the setting of the peak power meter.

Power Meter Parameter	Setting
Bandwidth	50MHz bandwidth is greater than the EUT emission bandwidth
Detector	AVERAGE

**4.3.3. Test Procedures**

Spectrum Parameter	Setting
RF Output Power Method	<input checked="" type="checkbox"/> ANSI C63.10 clause 6.10.2.1 (a) power meter method
RF Output Power Method	<input type="checkbox"/> ANSI C63.10 clause 6.10.2.1 (b) channel integration method
RF Output Power Method	<input type="checkbox"/> ANSI C63.10 clause 6.10.3.1 Method 1 - spectral trace averaging
RF Output Power Method	<input type="checkbox"/> ANSI C63.10 clause 6.10.3.2 Method 2 - zero-span mode with trace averaging

**4.3.4. Test Setup Layout**

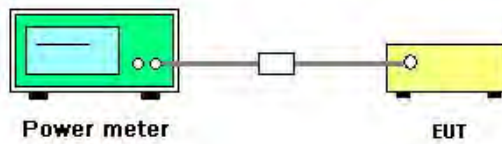

**4.3.5. Test Deviation**

There is no deviation with the original standard.

**4.3.6. EUT Operation during Test**

The EUT was programmed to be in continuously transmitting mode.

## 4.3.7. Test Result of Maximum Conducted Output Power

Temperature	23°C	Humidity	60%
Test Engineer	Allen Liu	Configurations	IEEE 802.11n (2TX/2RX)
Test Date	May 31, 2011		

## Configuration IEEE 802.11n MCS0 20MHz / Ant. 3 + Ant. 4

Channel	Frequency	Conducted Power (dBm)		Total Conducted Output Power (dBm)	Max. Limit (dBm)	Result
		Ant. 4	Ant. 3			
36	5180 MHz	13.80	13.28	16.56	17.00	Complies
40	5200 MHz	13.92	13.25	16.61	17.00	Complies
48	5240 MHz	13.94	13.40	16.69	17.00	Complies

## Configuration IEEE 802.11n MCS0 40MHz / Ant. 3+ Ant. 4

Channel	Frequency	Conducted Power (dBm)		Total Conducted Output Power (dBm)	Max. Limit (dBm)	Result
		Ant. 4	Ant. 3			
38	5190 MHz	13.14	13.54	16.35	17.00	Complies
46	5230 MHz	13.50	13.44	16.48	17.00	Complies



<b>Temperature</b>	23°C	<b>Humidity</b>	60%
<b>Test Engineer</b>	Sean Ku	<b>Configurations</b>	IEEE 802.11n (1TX/1RX)
<b>Test Date</b>	Oct. 04, 2011		

**Configuration IEEE 802.11n MCS0 20MHz / Ant. 3**

Channel	Frequency	Conducted Power (dBm)	Max. Limit (dBm)	Result
36	5180 MHz	16.81	17.00	Complies
40	5200 MHz	16.78	17.00	Complies
48	5240 MHz	16.77	17.00	Complies

**Configuration IEEE 802.11n MCS0 40MHz / Ant. 3**

Channel	Frequency	Conducted Power (dBm)	Max. Limit (dBm)	Result
38	5190 MHz	13.55	17.00	Complies
46	5230 MHz	16.43	17.00	Complies



<b>Temperature</b>	23°C	<b>Humidity</b>	60%
<b>Test Engineer</b>	Allen Liu	<b>Configurations</b>	IEEE 802.11a (1TX/1RX)
<b>Test Date</b>	May 31, 2011		

**Configuration IEEE 802.11a / Ant. 4**

<b>Channel</b>	<b>Frequency</b>	<b>Conducted Power (dBm)</b>	<b>Max. Limit (dBm)</b>	<b>Result</b>
36	5180 MHz	16.86	17.00	<b>Complies</b>
40	5200 MHz	16.73	17.00	<b>Complies</b>
48	5240 MHz	16.69	17.00	<b>Complies</b>



<b>Temperature</b>	23°C	<b>Humidity</b>	60%
<b>Test Engineer</b>	Sean Ku	<b>Configurations</b>	IEEE 802.11a (1TX/1RX)
<b>Test Date</b>	Oct. 04, 2011		

**Configuration IEEE 802.11a / Ant. 3**

<b>Channel</b>	<b>Frequency</b>	<b>Conducted Power (dBm)</b>	<b>Max. Limit (dBm)</b>	<b>Result</b>
36	5180 MHz	16.79	17.00	<b>Complies</b>
40	5200 MHz	16.76	17.00	<b>Complies</b>
48	5240 MHz	16.71	17.00	<b>Complies</b>

## 4.4. Power Spectral Density Measurement

### 4.4.1. Limit

The power spectral density is defined as the highest level of power in dBm per MHz generated by the transmitter within the power envelope. The following table is power spectral density limits and decrease power density limit rule refer to section 4.3.1.

Frequency Range	Power Spectral Density limit (dBm/MHz)
5.15~5.25 GHz	4

### 4.4.2. Measuring Instruments and Setting

Please refer to section 5 of equipments list in this report. The following table is the setting of the spectrum analyzer.

Spectrum Parameter	Setting
Attenuation	Auto
Span Frequency	Encompass the entire emissions bandwidth (EBW) of the signal
RB	1000 kHz
VB	3000 kHz
Detector	SAMPLE
Trace	AVERAGE
Sweep Time	Auto
Trace Average	100 times

### 4.4.3. Test Procedures

1. The transmitter output (antenna port) was connected to the spectrum analyzer.
2. Set RBW of spectrum analyzer to 1000kHz and VBW to 3000kHz. Set Detector to Peak, Trace to Max Hold. Mark the frequency with maximum peak power as the center of the display of the spectrum.
3. When measuring power spectral density with multiple antenna systems, add every result of the values by mathematic formula.



#### 4.4.4. Test Setup Layout

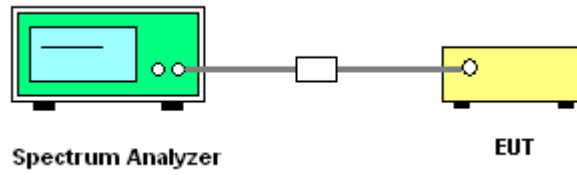

#### 4.4.5. Test Deviation

There is no deviation with the original standard.

#### 4.4.6. EUT Operation during Test

The EUT was programmed to be in continuously transmitting mode.

#### 4.4.7. Test Result of Power Spectral Density

<b>Temperature</b>	23°C	<b>Humidity</b>	60%
<b>Test Engineer</b>	Allen Liu	<b>Configurations</b>	IEEE 802.11n (2TX/2RX)
<b>Test Date</b>	May 31, 2011		

##### Configuration IEEE 802.11n MCS0 20MHz/ Ant. 3 + Ant. 4

Channel	Frequency	Power Density (dBm/3kHz)		Total Power Density (dBm/3kHz)	Max. Limit (dBm/3kHz)	Result
		Ant. 4	Ant. 3			
36	5180 MHz	-5.82	-6.73	-3.24	4.00	Complies
40	5200 MHz	-1.22	-7.34	-0.27	4.00	Complies
48	5240 MHz	-0.79	-7.99	-0.03	4.00	Complies

##### Configuration IEEE 802.11n MCS0 40MHz/ Ant. 3 + Ant. 4

Channel	Frequency	Power Density (dBm/3kHz)		Total Power Density (dBm/3kHz)	Max. Limit (dBm/3kHz)	Result
		Ant. 4	Ant. 3			
38	5190 MHz	-5.25	-11.10	-4.25	4.00	Complies
46	5230 MHz	-9.17	-9.60	-6.37	4.00	Complies

<b>Temperature</b>	23°C	<b>Humidity</b>	60%
<b>Test Engineer</b>	Sean Ku	<b>Configurations</b>	IEEE 802.11n (1TX/1RX)
<b>Test Date</b>	Oct. 04, 2011		

**Configuration IEEE 802.11n MCS0 20MHz/ Ant. 3**

Channel	Frequency	Power Density (dBm/3kHz)	Max. Limit (dBm/3kHz)	Result
36	5180 MHz	1.42	4.00	Complies
40	5200 MHz	1.36	4.00	Complies
48	5240 MHz	1.33	4.00	Complies

**Configuration IEEE 802.11n MCS0 40MHz/ Ant. 3**

Channel	Frequency	Power Density (dBm/3kHz)	Max. Limit (dBm/3kHz)	Result
38	5190 MHz	-5.69	4.00	Complies
46	5230 MHz	-2.02	4.00	Complies



<b>Temperature</b>	23°C	<b>Humidity</b>	60%
<b>Test Engineer</b>	Allen Liu	<b>Configurations</b>	IEEE 802.11a (1TX/1RX)
<b>Test Date</b>	May 31, 2011		

**Configuration IEEE 802.11a / Ant. 4**

<b>Channel</b>	<b>Frequency</b>	<b>Power Density (dBm)</b>	<b>Max. Limit (dBm)</b>	<b>Result</b>
36	5180 MHz	-3.08	4.00	<b>Complies</b>
40	5200 MHz	-3.35	4.00	<b>Complies</b>
48	5240 MHz	-3.62	4.00	<b>Complies</b>



<b>Temperature</b>	23°C	<b>Humidity</b>	60%
<b>Test Engineer</b>	Sean Ku	<b>Configurations</b>	IEEE 802.11a (1TX/1RX)
<b>Test Date</b>	Oct. 04, 2011		

**Configuration IEEE 802.11a / Ant. 3**

<b>Channel</b>	<b>Frequency</b>	<b>Power Density (dBm)</b>	<b>Max. Limit (dBm)</b>	<b>Result</b>
36	5180 MHz	1.46	4.00	<b>Complies</b>
40	5200 MHz	1.70	4.00	<b>Complies</b>
48	5240 MHz	1.60	4.00	<b>Complies</b>

Note: All the test values were listed in the report.

For plots, only the channel with maximum results was shown.

<IEEE 802.11n (2TX/2RX)>

Power Density Plot on Configuration IEEE 802.11n MCS0 20MHz / Ant. 4 / 5240 MHz

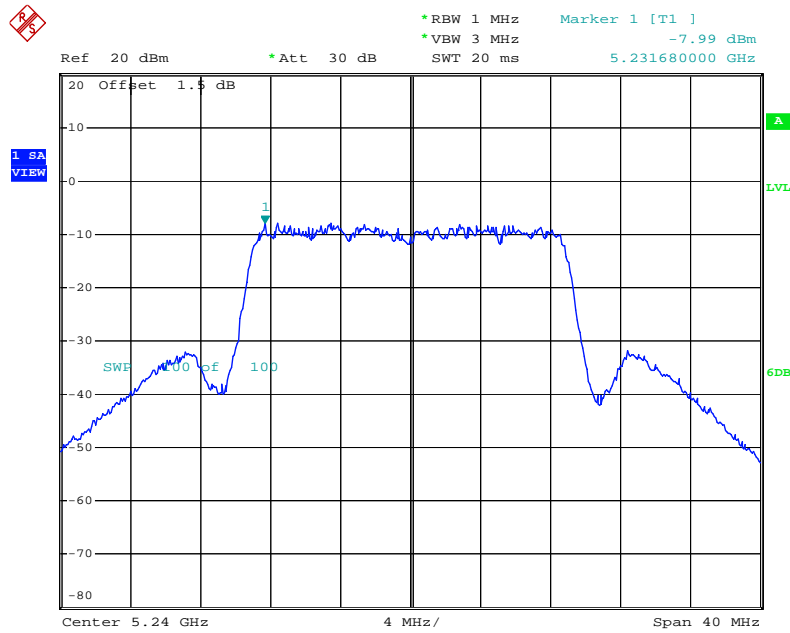

Date: 31.MAY.2011 06:52:47

Power Density Plot on Configuration IEEE 802.11n MCS0 20MHz / Ant. 3 / 5240 MHz

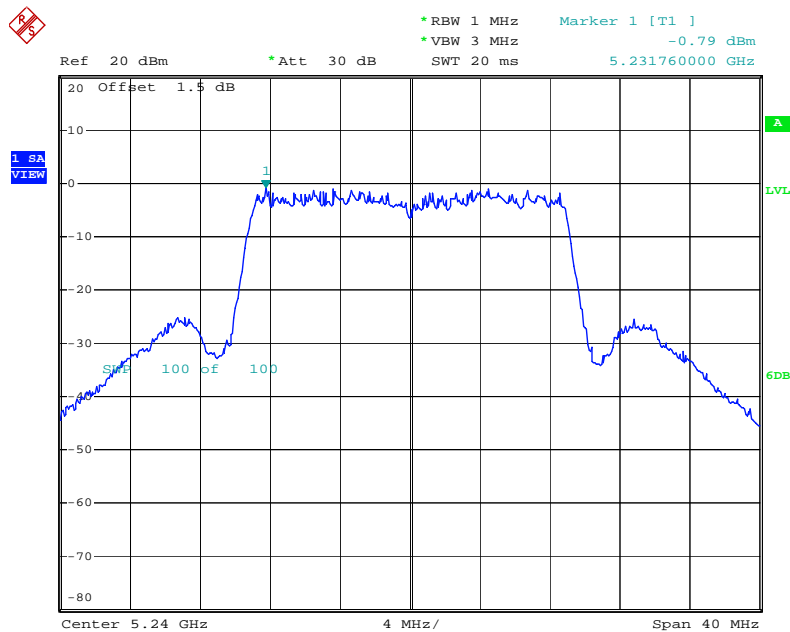

Date: 31.MAY.2011 06:52:14

**Power Density Plot on Configuration IEEE 802.11n MCS0 40MHz / Ant. 4 / 5190 MHz**

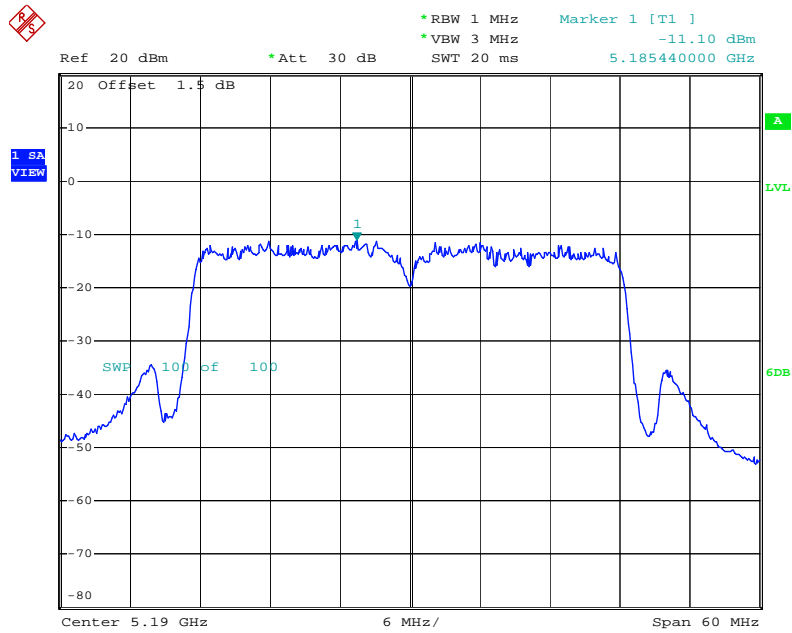

Date: 31.MAY.2011 07:06:43

**Power Density Plot on Configuration IEEE 802.11n MCS0 40MHz / Ant. 3 / 5190 MHz**

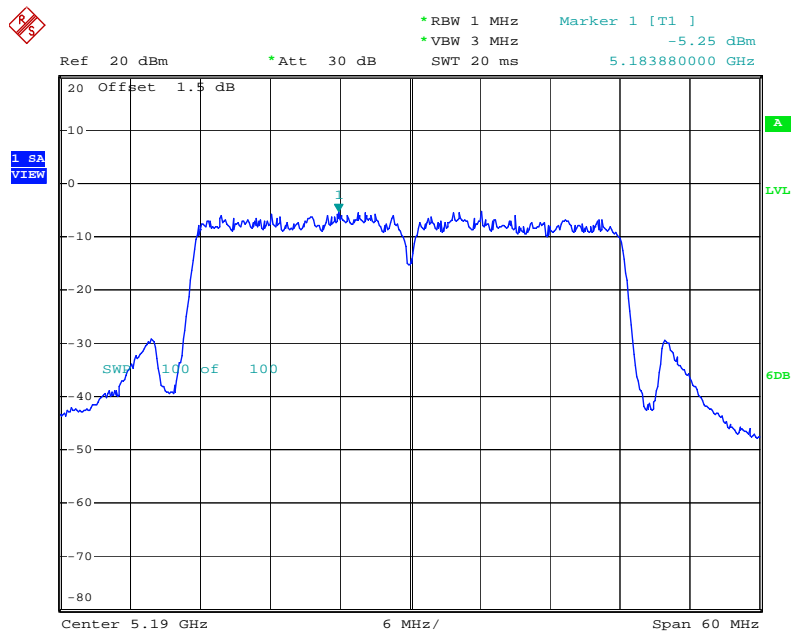

Date: 31.MAY.2011 07:06:10

<IEEE 802.11n (1TX/1RX)>

Power Density Plot on Configuration IEEE 802.11n MCS0 20MHz / Ant. 3 / 5180 MHz

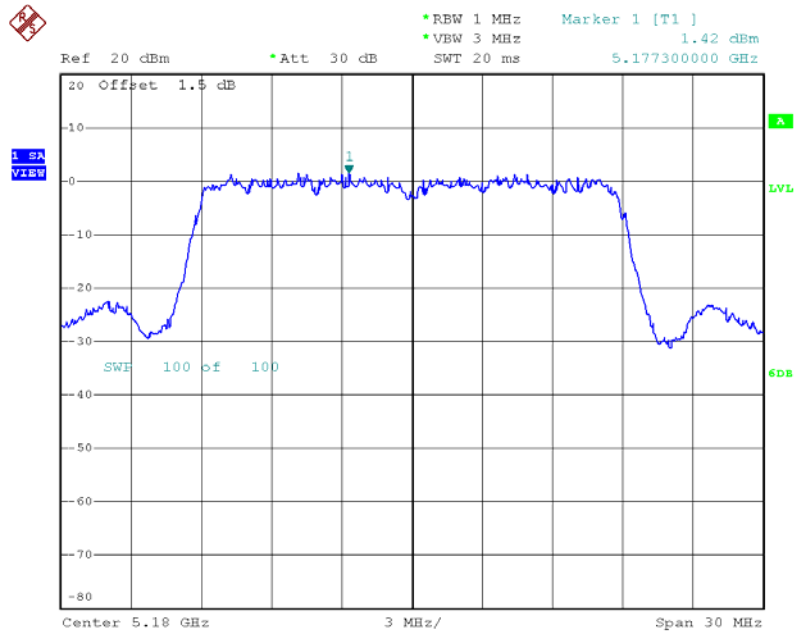

Date: 4.OCT.2011 04:16:08

Power Density Plot on Configuration IEEE 802.11n MCS0 40MHz / Ant. 3 / 5230 MHz

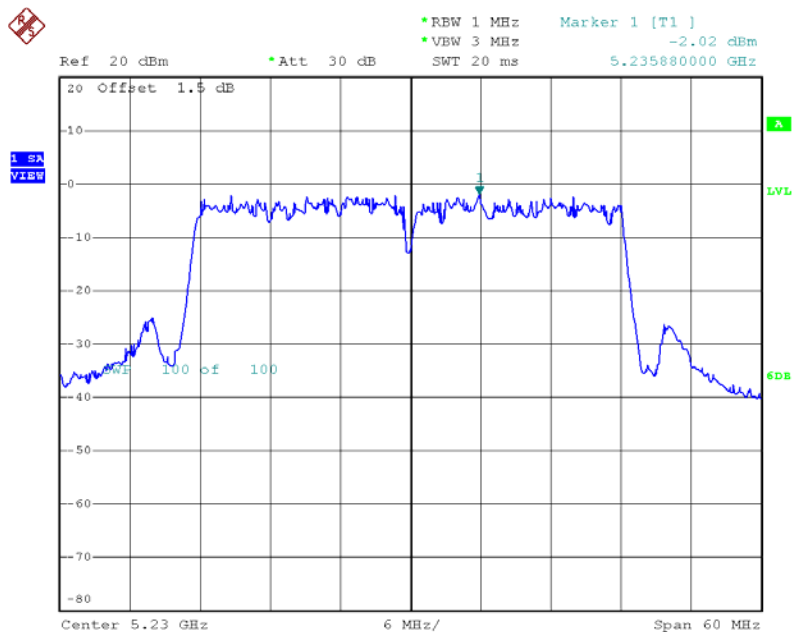

Date: 4.OCT.2011 04:10:51



## &lt;IEEE 802.11a (1TX/1RX)&gt;

## Power Density Plot on Configuration IEEE 802.11a / Ant. 4 / 5180 MHz

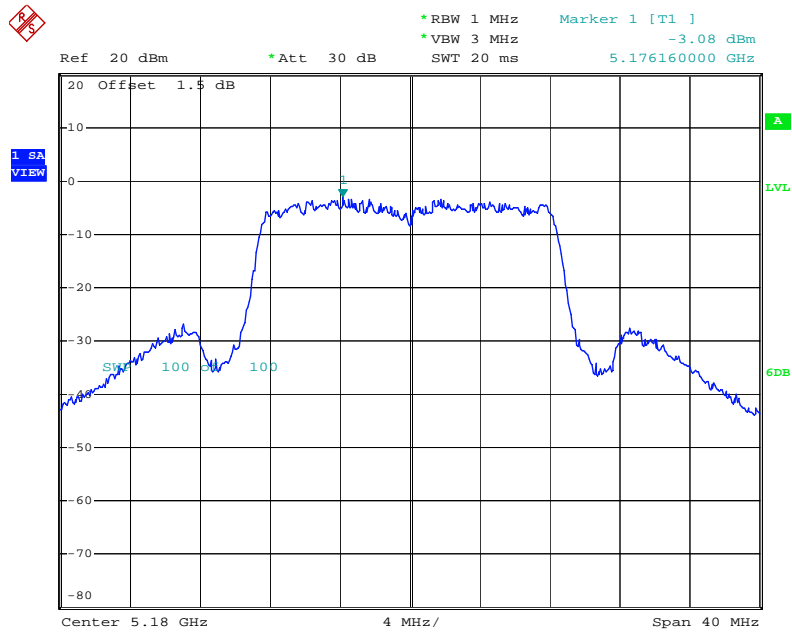

Date: 31.MAY.2011 06:34:12

## &lt;IEEE 802.11a (1TX/1RX)&gt;

## Power Density Plot on Configuration IEEE 802.11a / Ant. 3 / 5200 MHz

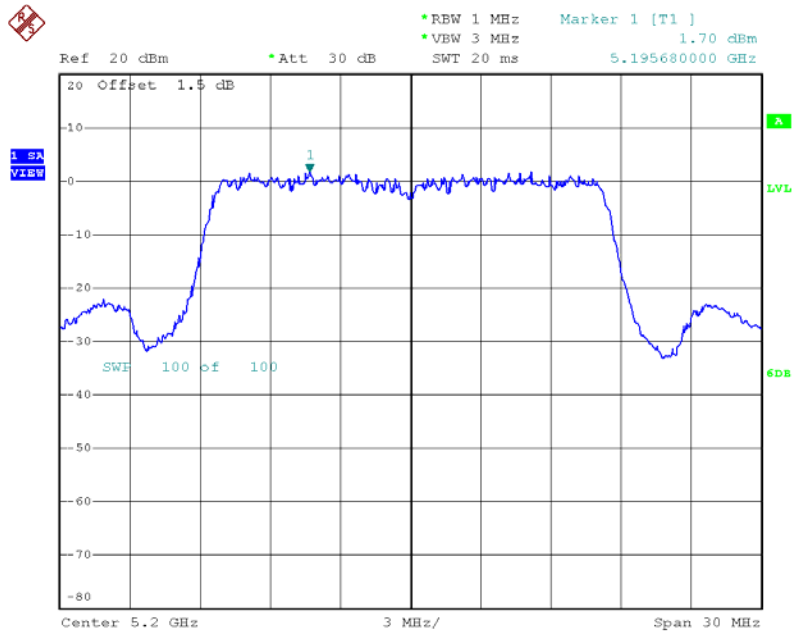

Date: 4.OCT.2011 04:18:22

## 4.5. Peak Excursion Measurement

### 4.5.1. Limit

The ratio of the peak excursion of the modulation envelope (measured using a peak hold function) to the maximum conducted output power (measured as specified above) shall not exceed 13 dB across any 1 MHz bandwidth or the emissions bandwidth whichever is less.

### 4.5.2. Measuring Instruments and Setting

Please refer to section 5 of equipments list in this report. The following table is the setting of the spectrum analyzer.

Spectrum Parameter	Setting
Attenuation	Auto
Span Frequency	Encompass the entire emissions bandwidth (EBW) of the signal
RB	1000 kHz (Peak Trace) / 1000 kHz (Average Trace)
VB	3000 kHz (Peak Trace) / 300 kHz (Average Trace)
Detector	Peak (Peak Trace) / Sample (Average Trace)
Trace	Max Hold
Sweep Time	60s

### 4.5.3. Test Procedures

1. The test procedure is the same as section 4.6.3.
2. Trace A, Set RBW = 1MHz, VBW = 3MHz, Span >26dB bandwidth, Max. hold.
3. Delta Mark trace A Maximum frequency and trace B same frequency.
4. Repeat the above procedure until measurements for all frequencies were complete.

### 4.5.4. Test Setup Layout

This test setup layout is the same as that shown in section 4.6.4.

### 4.5.5. Test Deviation

There is no deviation with the original standard.

### 4.5.6. EUT Operation during Test

The EUT was programmed to be in continuously transmitting mode.

#### 4.5.7. Test Result of Peak Excursion

<b>Temperature</b>	23°C	<b>Humidity</b>	60%
<b>Test Engineer</b>	Sam Lee	<b>Configurations</b>	IEEE 802.11n (2TX/2RX)
<b>Test Date</b>	May 31, 2011		

##### Configuration IEEE 802.11n MCS0 20MHz / Ant. 3 + Ant. 4

Channel	Frequency	Peak Excursion (dB)	Max. Limit (dB)	Result
36	5180 MHz	4.78	13	Complies
40	5200 MHz	4.80	13	Complies
48	5240 MHz	5.24	13	Complies

##### Configuration IEEE 802.11n MCS0 40MHz / Ant. 3 + Ant. 4

Channel	Frequency	Peak Excursion (dB)	Max. Limit (dB)	Result
38	5190 MHz	5.61	13	Complies
46	5230 MHz	5.22	13	Complies



<b>Temperature</b>	23°C	<b>Humidity</b>	60%
<b>Test Engineer</b>	Sean Ku	<b>Configurations</b>	IEEE 802.11n (1TX/1RX)
<b>Test Date</b>	Oct. 04, 2011		

**Configuration IEEE 802.11n MCS0 20MHz / Ant. 3**

<b>Channel</b>	<b>Frequency</b>	<b>Peak Excursion (dB)</b>	<b>Max. Limit (dB)</b>	<b>Result</b>
36	5180 MHz	5.99	13	<b>Complies</b>
40	5200 MHz	5.26	13	<b>Complies</b>
48	5240 MHz	5.45	13	<b>Complies</b>

**Configuration IEEE 802.11n MCS0 40MHz / Ant. 3**

<b>Channel</b>	<b>Frequency</b>	<b>Peak Excursion (dB)</b>	<b>Max. Limit (dB)</b>	<b>Result</b>
38	5190 MHz	6.09	13	<b>Complies</b>
46	5230 MHz	5.63	13	<b>Complies</b>



<b>Temperature</b>	23°C	<b>Humidity</b>	60%
<b>Test Engineer</b>	Sam Lee	<b>Configurations</b>	IEEE 802.11a (1TX/1RX)
<b>Test Date</b>	May 31, 2011		

**Configuration IEEE 802.11a / Ant. 4**

<b>Channel</b>	<b>Frequency</b>	<b>Peak Excursion (dB)</b>	<b>Max. Limit (dB)</b>	<b>Result</b>
36	5180 MHz	5.71	13	<b>Complies</b>
40	5200 MHz	5.54	13	<b>Complies</b>
48	5240 MHz	6.32	13	<b>Complies</b>



<b>Temperature</b>	23°C	<b>Humidity</b>	60%
<b>Test Engineer</b>	Sean Ku	<b>Configurations</b>	IEEE 802.11a (1TX/1RX)
<b>Test Date</b>	Oct. 04, 2011		

**Configuration IEEE 802.11a / Ant. 3**

<b>Channel</b>	<b>Frequency</b>	<b>Peak Excursion (dB)</b>	<b>Max. Limit (dB)</b>	<b>Result</b>
36	5180 MHz	5.71	13	<b>Complies</b>
40	5200 MHz	5.54	13	<b>Complies</b>
48	5240 MHz	6.32	13	<b>Complies</b>

Note: All the test values were listed in the report.

For plots, only the channel with maximum results was shown.

<IEEE 802.11n (2TX/2RX)>

Peak Excursion Plot on Configuration IEEE 802.11n MCS0 20MHz / Ant. 3 + Ant. 4 / 5240 MHz

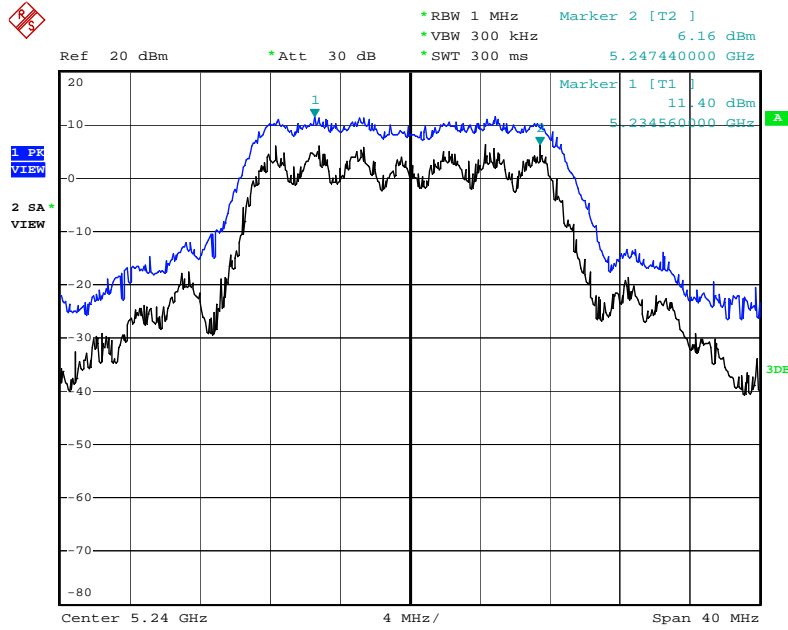

Date: 4.JUL.2011 07:14:30

Peak Excursion Plot on Configuration IEEE 802.11n MCS0 40MHz / Ant. 3 + Ant. 4 / 5190 MHz

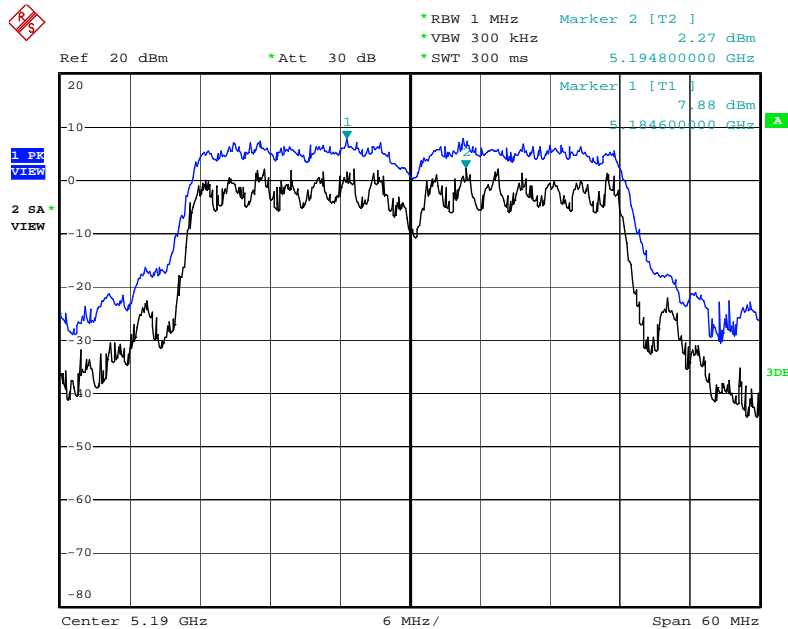

Date: 4.JUL.2011 07:59:17



<IEEE 802.11n (1TX/1RX)>

Peak Excursion Plot on Configuration IEEE 802.11n MCS0 20MHz / Ant. 3 + Ant. 4 / 5180 MHz

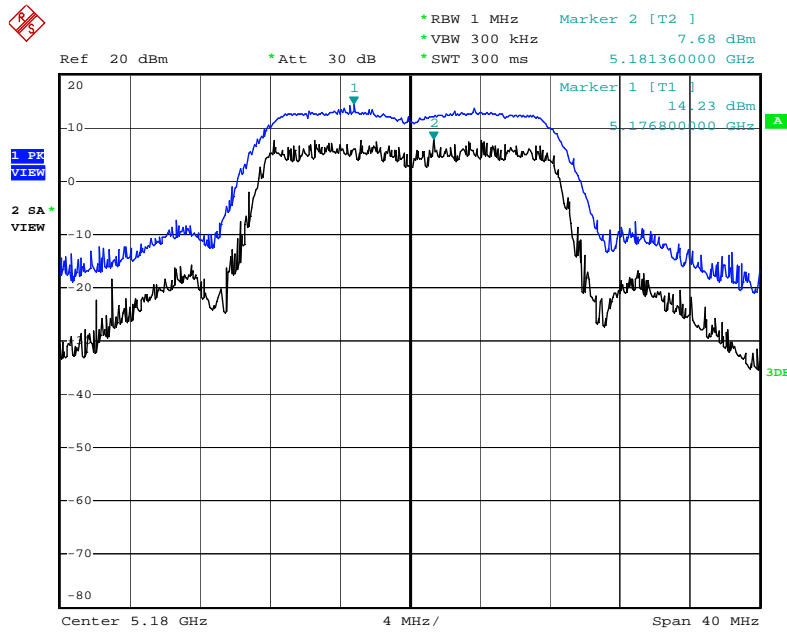

Date: 4.OCT.2011 03:53:32

Peak Excursion Plot on Configuration IEEE 802.11n MCS0 40MHz / Ant. 3 + Ant. 4 / 5190 MHz

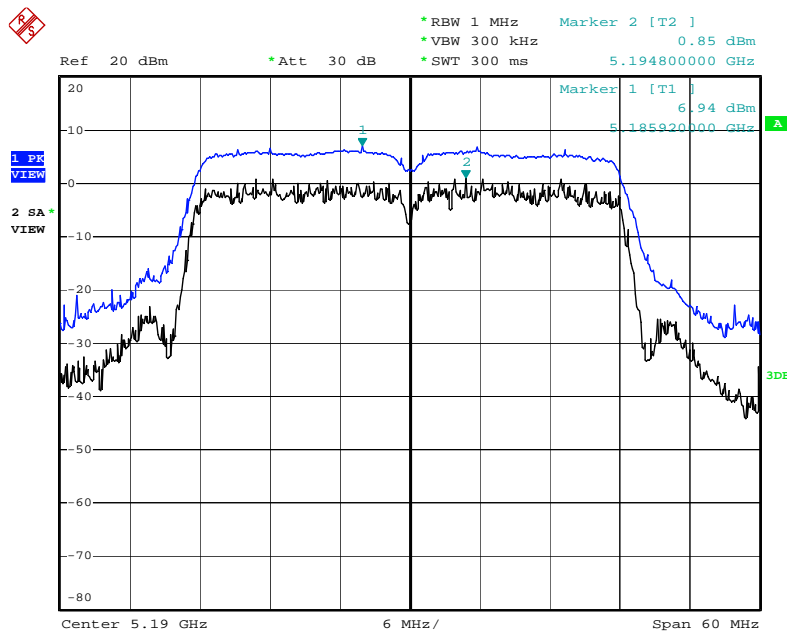

Date: 4.OCT.2011 04:04:37

<IEEE 802.11a (1TX/1RX)>

Peak Excursion Plot on Configuration IEEE 802.11a / Ant. 4 / 5240 MHz

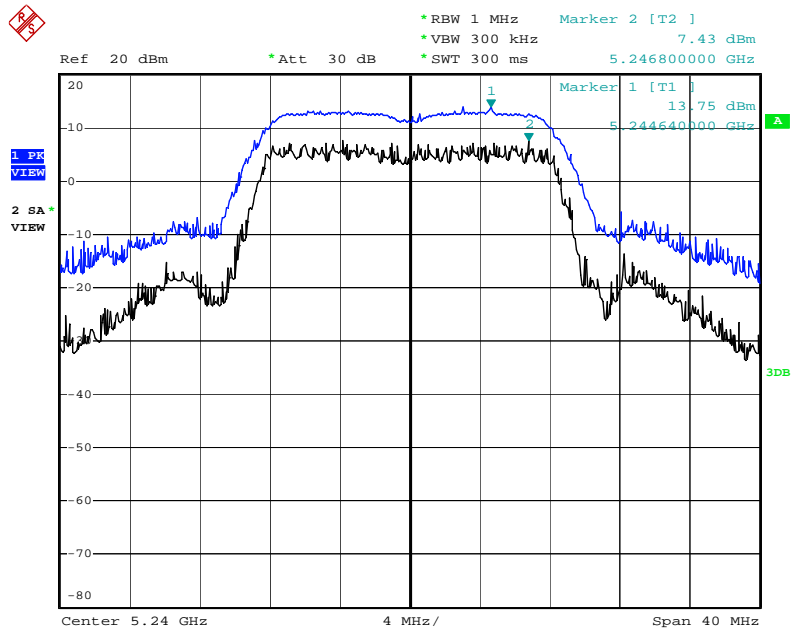

Date: 4.JUL.2011 08:12:35

<IEEE 802.11a (1TX/1RX)>

Peak Excursion Plot on Configuration IEEE 802.11a / Ant. 3 / 5180 MHz

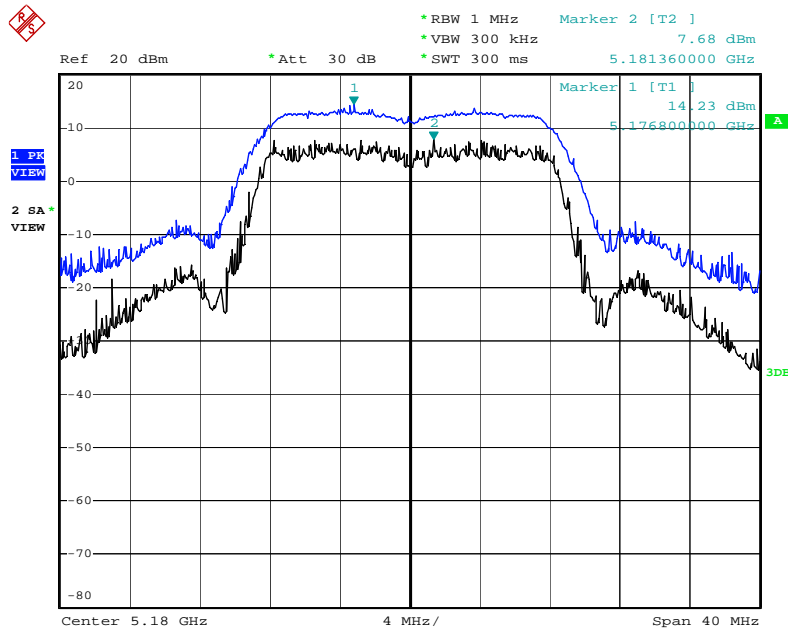

Date: 4.OCT.2011 03:53:32

## 4.6. Radiated Emissions Measurement

### 4.6.1. Limit

For transmitters operating in the 5.15-5.25 GHz band: all emissions outside of the 5.15-5.35 GHz band shall not exceed an EIRP of -27 dBm/MHz (68.3dBuV/m at 3m). In addition, In case the emission fall within the restricted band specified on 15.205(a), then the 15.209(a) limit in the table below has to be followed.

Frequencies (MHz)	Field Strength (micorvolts/meter)	Measurement Distance (meters)
0.009~0.490	2400/F(KHz)	300
0.490~1.705	24000/F(KHz)	30
1.705~30.0	30	30
30~88	100	3
88~216	150	3
216~960	200	3
Above 960	500	3

### 4.6.2. Measuring Instruments and Setting

Please refer to section 5 of equipments list in this report. The following table is the setting of spectrum analyzer and receiver.

Spectrum Parameter	Setting
Attenuation	Auto
Start Frequency	1000 MHz
Stop Frequency	40 GHz
RB / VB (Emission in restricted band)	1MHz / 1MHz for Peak, 1 MHz / 10Hz for Average
RB / VB (Emission in non-restricted band)	1000KHz / 1000KHz for peak

Receiver Parameter	Setting
Attenuation	Auto
Start ~ Stop Frequency	9kHz~150kHz / RB 200Hz for QP
Start ~ Stop Frequency	150kHz~30MHz / RB 9kHz for QP
Start ~ Stop Frequency	30MHz~1000MHz / RB 120kHz for QP

#### 4.6.3. Test Procedures

1. Configure the EUT according to ANSI C63.10. The EUT was placed on the top of the turntable 0.8 meter above ground. The phase center of the receiving antenna mounted on the top of a height-variable antenna tower was placed 3 meters far away from the turntable.
2. Power on the EUT and all the supporting units. The turntable was rotated by 360 degrees to determine the position of the highest radiation.
3. The height of the broadband receiving antenna was varied between one meter and four meters above ground to find the maximum emissions field strength of both horizontal and vertical polarization.
4. For each suspected emissions, the antenna tower was scan (from 1 M to 4 M) and then the turntable was rotated (from 0 degree to 360 degrees) to find the maximum reading.
5. Set the test-receiver system to Peak or CISPR quasi-peak Detect Function with specified bandwidth under Maximum Hold Mode.
6. For emissions above 1GHz, use 1MHz VBW and RBW for peak reading. Then 1MHz RBW and 10Hz VBW for average reading in spectrum analyzer.
7. When the radiated emissions limits are expressed in terms of the average value of the emissions, and pulsed operation is employed, the measurement field strength shall be determined by averaging over one complete pulse train, including blanking intervals, as long as the pulse train does not exceed 0.1 seconds. As an alternative (provided the transmitter operates for longer than 0.1 seconds) or in cases where the pulse train exceeds 0.1 seconds, the measured field strength shall be determined from the average absolute voltage during a 0.1 second interval during which the field strength is at its maximum value.
8. If the emissions level of the EUT in peak mode was 3 dB lower than the average limit specified, then testing will be stopped and peak values of EUT will be reported, otherwise, the emissions which do not have 3 dB margin will be repeated one by one using the quasi-peak method for below 1GHz.
9. For testing above 1GHz, the emissions level of the EUT in peak mode was lower than average limit (that means the emissions level in peak mode also complies with the limit in average mode), then testing will be stopped and peak values of EUT will be reported, otherwise, the emissions will be measured in average mode again and reported.
10. In case the emission is lower than 30MHz, loop antenna has to be used for measurement and the recorded data should be QP measured by receiver. High – Low scan is not required in this case.

#### 4.6.4. Test Setup Layout

For radiated emissions below 1GHz

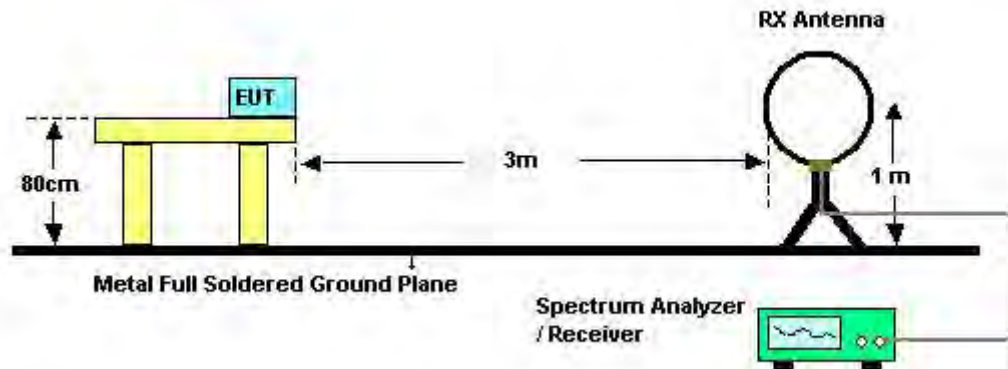

For radiated emissions above 1GHz

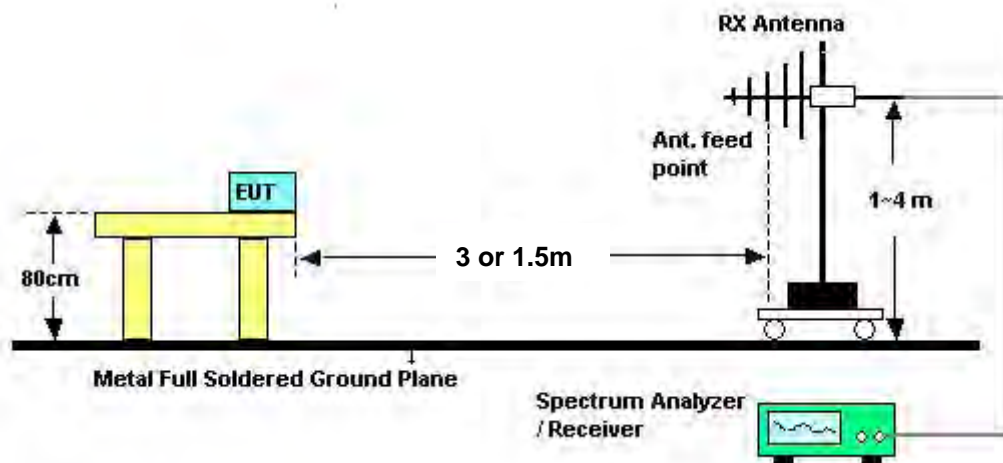

Above 5GHz shall be extrapolated to the specified distance using an extrapolation factor of 20 dB/decade from 3m to 1.5m.

Distance extrapolation factor =  $20 \log (\text{specific distance [3m]} / \text{test distance [1.5m]})$  (dB);

Limit line = specific limits (dBuV) + distance extrapolation factor [6 dB].

#### 4.6.5. Test Deviation

There is no deviation with the original standard.

#### 4.6.6. EUT Operation during Test

The EUT was programmed to be in continuously transmitting mode.

## 4.6.7. Results of Radiated Emissions (9kHz~30MHz)

<b>Temperature</b>	24°C	<b>Humidity</b>	60%
<b>Test Engineer</b>	Benson Peng	<b>Configurations</b>	Normal Link / Mode 2
<b>Test Date</b>	Jun. 02, 2011		

<b>Freq. (MHz)</b>	<b>Level (dBuV)</b>	<b>Over Limit (dB)</b>	<b>Limit Line (dBuV)</b>	<b>Remark</b>
-	-	-	-	See Note

Note:

The amplitude of spurious emissions that are attenuated by more than 20dB below the permissible value has no need to be reported.

Distance extrapolation factor =  $40 \log(\text{specific distance} / \text{test distance})$  (dB);

Limit line = specific limits (dBuV) + distance extrapolation factor.

4.6.8. Results of Radiated Emissions (30MHz~1GHz)

Temperature	24°C	Humidity	60%
Test Engineer	Benson Peng	Configurations	Normal Link / Mode 2

Horizontal

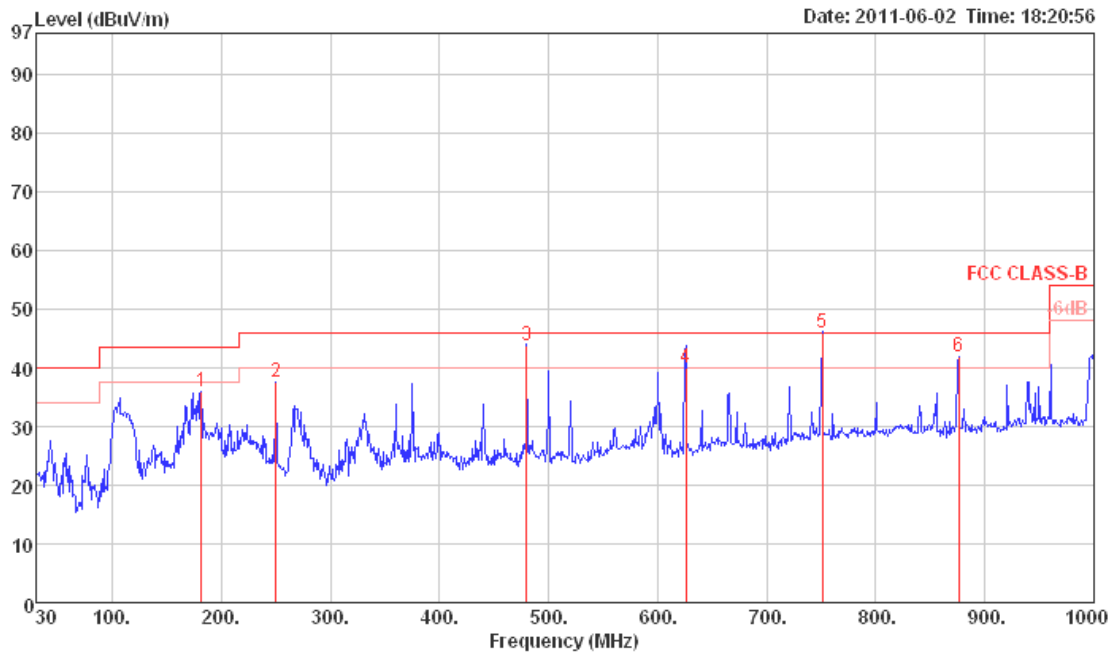

	Freq	Level	Limit	Over	Read	CableAntenna	Preamp	Remark	Pol/Phase
	MHz	dBuV/m	dBuV/m	dB	dBuV	Loss	Factor	dB	
1	181.32	35.83	43.50	-7.67	48.48	1.60	12.94	27.19	Peak HORIZONTAL
2	250.19	37.50	46.00	-8.50	49.83	1.90	12.77	27.00	Peak HORIZONTAL
3	480.08	43.67	46.00	-2.33	51.70	2.66	17.31	28.00	QP HORIZONTAL
4	625.58	40.08	46.00	-5.92	46.25	3.05	18.85	28.07	QP HORIZONTAL
6	875.84	41.76	46.00	-4.24	45.36	3.50	20.35	27.45	Peak HORIZONTAL



**Vertical**

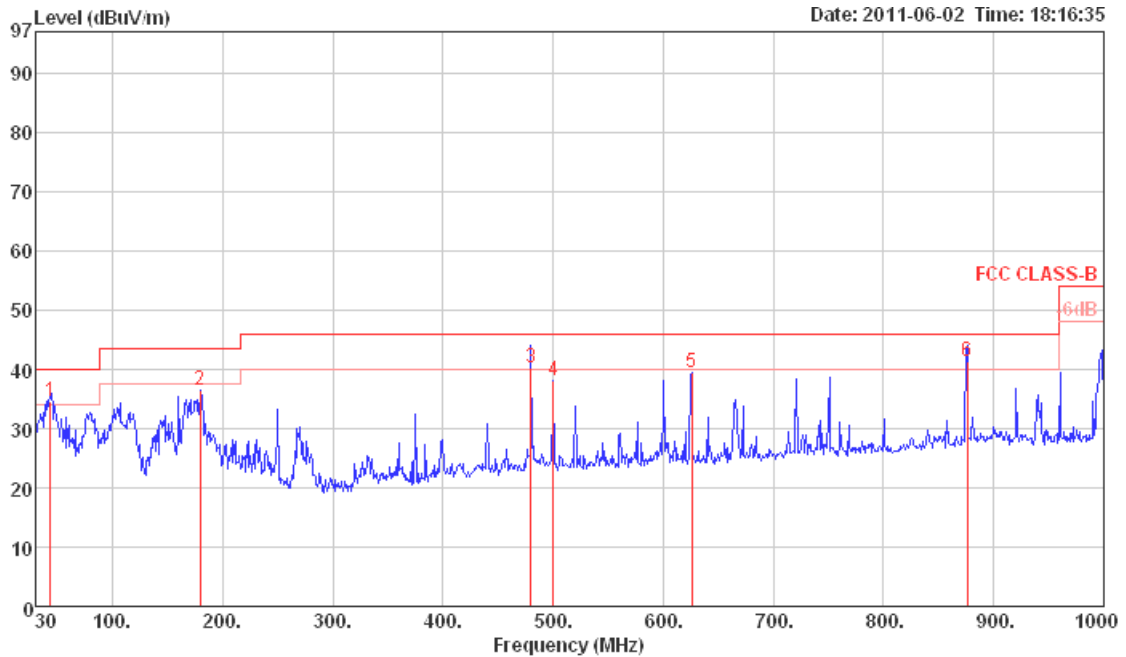

	Freq	Level	Limit Line	Over Limit	Read Level	CableAntenna Loss	Preamp Factor	Preamp Factor	Remark	Pol/Phase
	MHz	dBuV/m	dBuV/m	dB	dBuV	dB	dB/m	dB		
1	43.58	34.48	40.00	-5.52	50.70	0.70	10.88	27.80	QP	VERTICAL
2	179.38	36.44	43.50	-7.06	48.90	1.60	13.14	27.20	Peak	VERTICAL
3	480.08	40.37	46.00	-5.63	48.40	2.66	17.31	28.00	QP	VERTICAL
4	500.45	38.18	46.00	-7.82	45.95	2.70	17.63	28.10	Peak	VERTICAL
5	625.58	39.55	46.00	-6.45	45.72	3.05	18.85	28.07	Peak	VERTICAL
6	875.84	41.45	46.00	-4.55	45.05	3.50	20.35	27.45	QP	VERTICAL

**Note:**

The amplitude of spurious emissions that are attenuated by more than 20dB below the permissible value has no need to be reported.

Emission level (dBuV/m) = 20 log Emission level (uV/m).

Corrected Reading: Antenna Factor + Cable Loss + Read Level - Preamp Factor = Level.

4.6.9. Results for Radiated Emissions (1GHz~40GHz)

<IEEE 802.11n (2TX/2RX)>

Temperature	24°C	Humidity	60%
Test Engineer	Benson Peng	Configurations	IEEE 802.11n (2TX/2RX) MCS0 20MHz Ch 36 / Mode 1 / Ant. 3 + Ant. 4

Horizontal

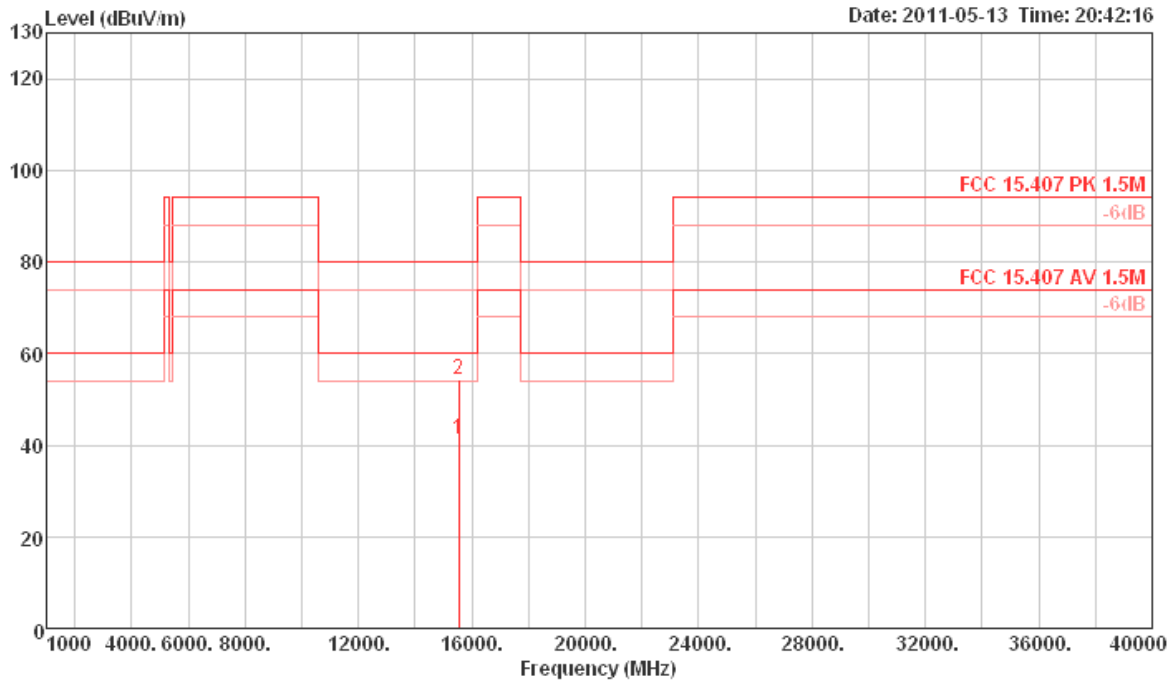

	Freq	Level	Limit Line	Over Limit	Read Level	CableAntenna Loss	Antenna Factor	Preamp Factor	Remark	Pol/Phase
	MHz	dBuV/m	dBuV/m	dB	dBuV	dB	dB/m	dB		
1	15538.61	41.17	60.00	-18.83	30.38	8.26	38.12	35.59	Average	HORIZONTAL
2	15540.40	54.37	80.00	-25.63	43.58	8.26	38.12	35.59	Peak	HORIZONTAL

**Vertical**

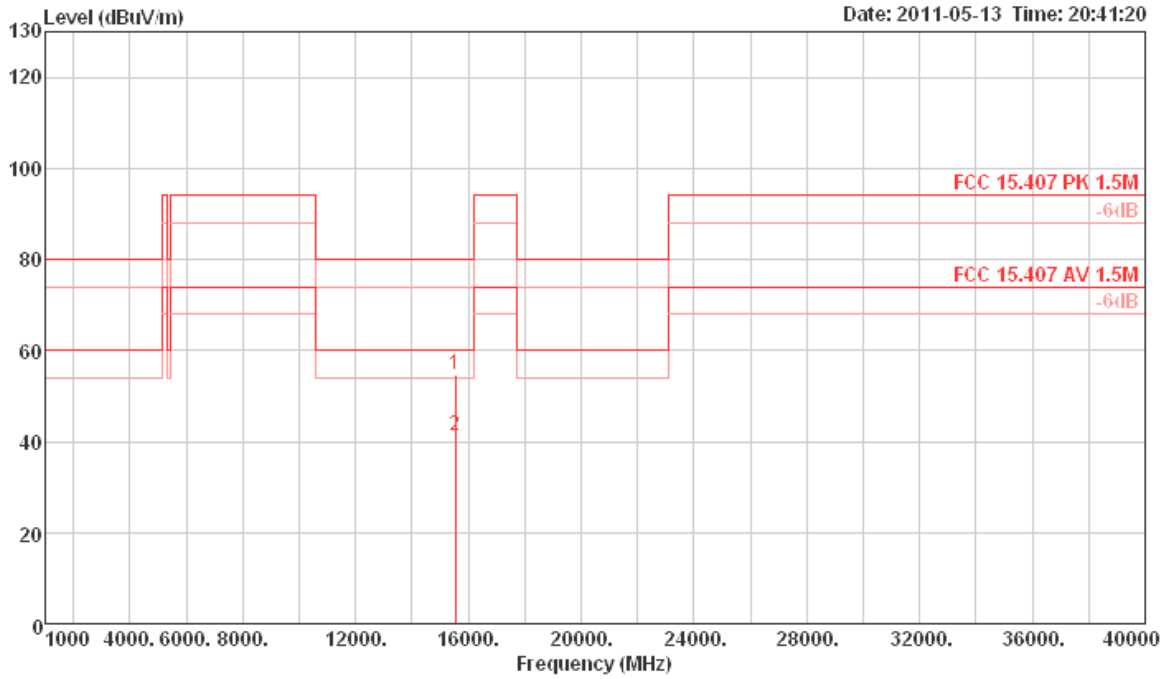

	Freq	Level	Limit Line	Over Limit	Read Level	CableAntenna Loss	Antenna Factor	Preamp Factor	Remark	Pol/Phase
	MHz	dBuV/m	dBuV/m	dB	dBuV	dB	dB/m	dB		
1	15539.96	54.69	80.00	-25.31	43.90	8.26	38.12	35.59	Peak	VERTICAL
2	15540.08	41.19	60.00	-18.81	30.40	8.26	38.12	35.59	Average	VERTICAL

<b>Temperature</b>	24°C	<b>Humidity</b>	60%
<b>Test Engineer</b>	Benson Peng	<b>Configurations</b>	IEEE 802.11n (2TX/2RX) MCS0 20MHz Ch 40 / Mode 1 / Ant. 3 + Ant. 4

**Horizontal**

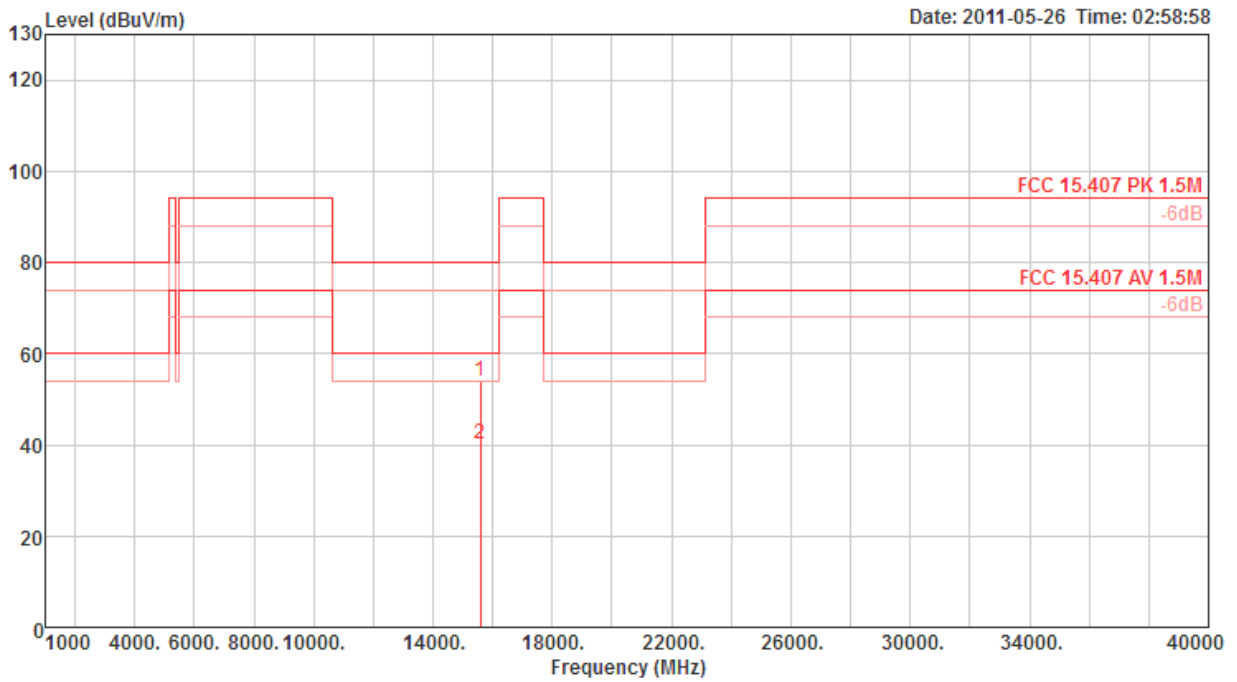

	Freq	Level	Limit	Over	Read	Cable	Preamp	Antenna	T/Pos	A/Pos	Remark	Pol/Phase
	MHz	dBuV/m	dBuV/m	dB	dBuV	dB	dB	dB/m	deg	cm		
1 p	15599.79	53.89	80.00	-26.11	44.25	6.11	34.77	38.30	328	100	Peak	HORIZONTAL
2 a	15599.82	40.23	60.00	-19.77	30.59	6.11	34.77	38.30	328	100	Average	HORIZONTAL

**Vertical**

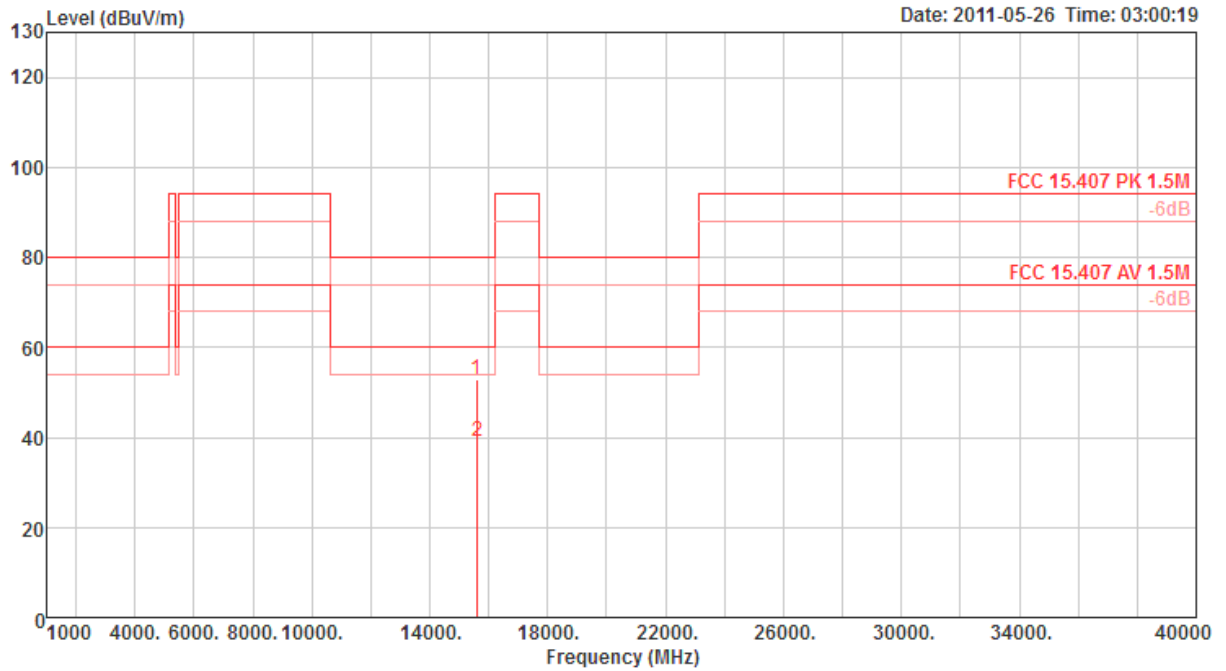

	Freq	Level	Limit	Over	Read	Cable	Preamp	Antenna	T/Pos	A/Pos	Remark	Pol/Phase
	MHz	dBuV/m	dBuV/m	dB	dBuV	dB	dB	dB/m	deg	cm		
1 p	15598.92	52.91	80.00	-27.09	43.27	6.11	34.77	38.30	46	100	Peak	VERTICAL
2 a	15605.04	39.11	60.00	-20.89	29.47	6.11	34.77	38.30	46	100	Average	VERTICAL

<b>Temperature</b>	24°C	<b>Humidity</b>	60%
<b>Test Engineer</b>	Benson Peng	<b>Configurations</b>	IEEE 802.11n (2TX/2RX) MCS0 20MHz Ch 48 / Mode 1 / Ant. 3 + Ant. 4

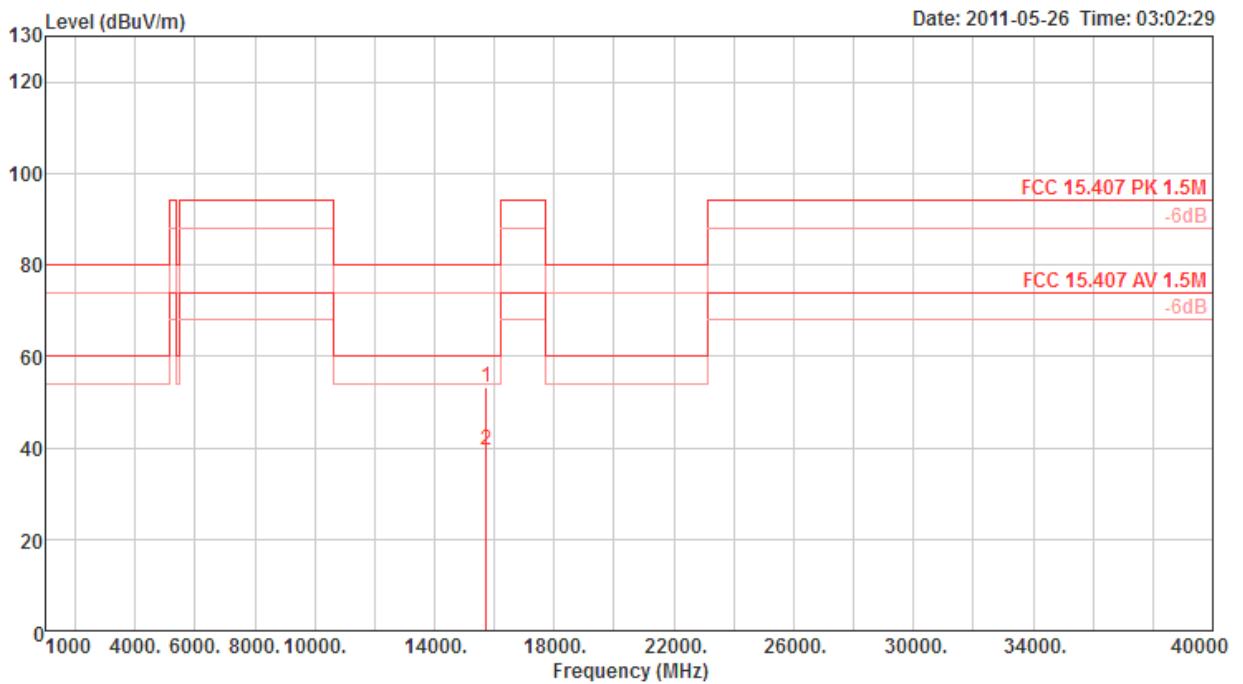
**Horizontal**

	Freq	Level	Limit	Over	Read	Cable	Preamp	Antenna	T/Pos	A/Pos	Remark	Pol/Phase
	MHz	dBuV/m	dBuV/m	dB	dBuV	Loss	Factor	Factor	deg	cm		
1 p	15721.33	53.21	80.00	-26.79	43.54	6.11	34.86	38.42	222	100	Peak	HORIZONTAL
2 a	15721.94	39.40	60.00	-20.60	29.73	6.11	34.86	38.42	222	100	Average	HORIZONTAL

**Vertical**

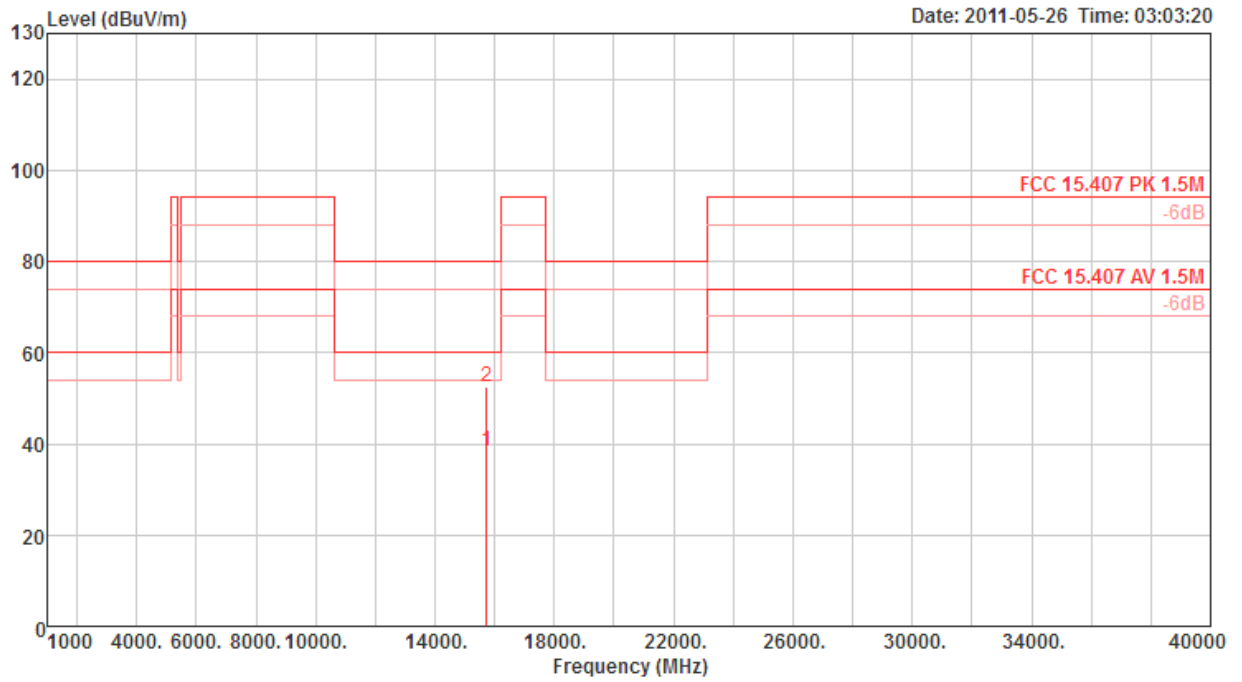

	Freq	Level	Limit	Over	Read	Cable	Preamp	Antenna	T/Pos	A/Pos	Remark	Pol/Phase
	MHz	dBuV/m	dBuV/m	dB	dBuV	dB	dB	dB/m	deg	cm		
1 a	15717.54	38.54	60.00	-21.46	28.87	6.11	34.86	38.42	172	100	Average	VERTICAL
2 p	15721.96	52.41	80.00	-27.59	42.74	6.11	34.86	38.42	172	100	Peak	VERTICAL

<b>Temperature</b>	24°C	<b>Humidity</b>	60%
<b>Test Engineer</b>	Benson Peng	<b>Configurations</b>	IEEE 802.11n (2TX/2RX) MCS0 40MHz Ch 38 / Mode 1 / Ant. 3 + Ant. 4

**Horizontal**

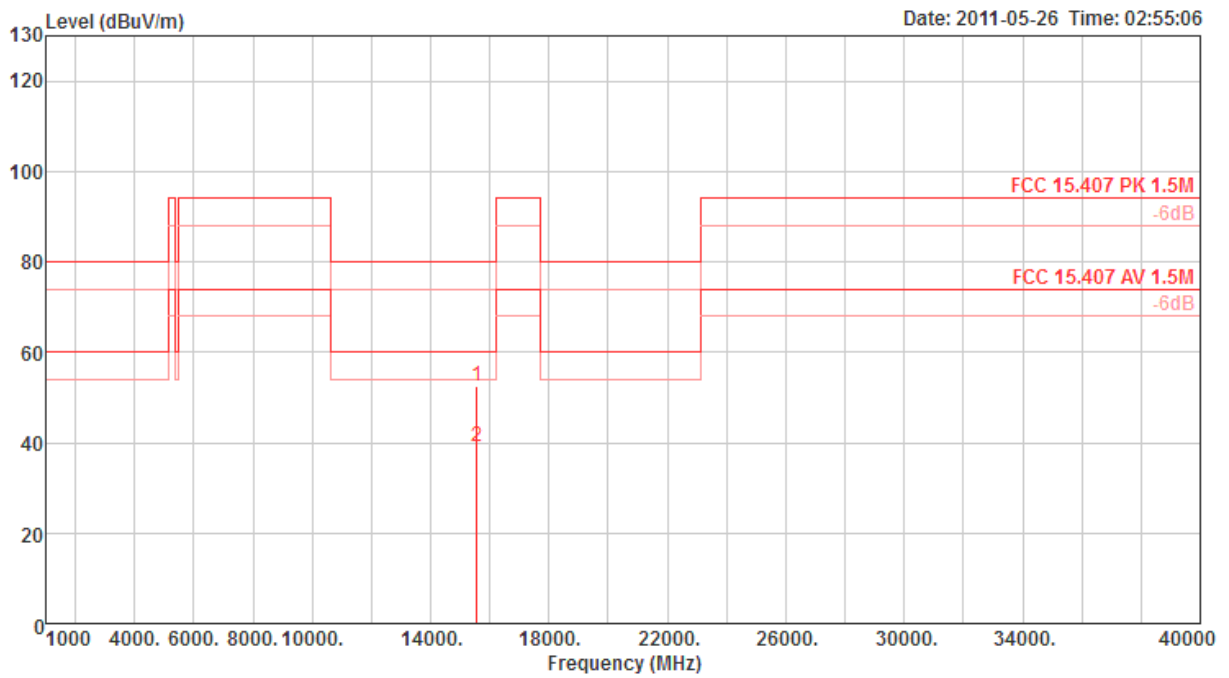

	Freq	Level	Limit Line	Over Limit	Read Level	Cable Loss	Preamp Factor	Antenna Factor	T/Pos	A/Pos	Remark	Pol/Phase
	MHz	dBuV/m	dBuV/m	dB	dBuV	dB	dB	dB/m	deg	cm		
1 p	15567.75	52.65	80.00	-27.35	42.99	6.11	34.72	38.27	220	100	Peak	HORIZONTAL
2 a	15569.35	39.10	60.00	-20.90	29.44	6.11	34.72	38.27	220	100	Average	HORIZONTAL



**Vertical**

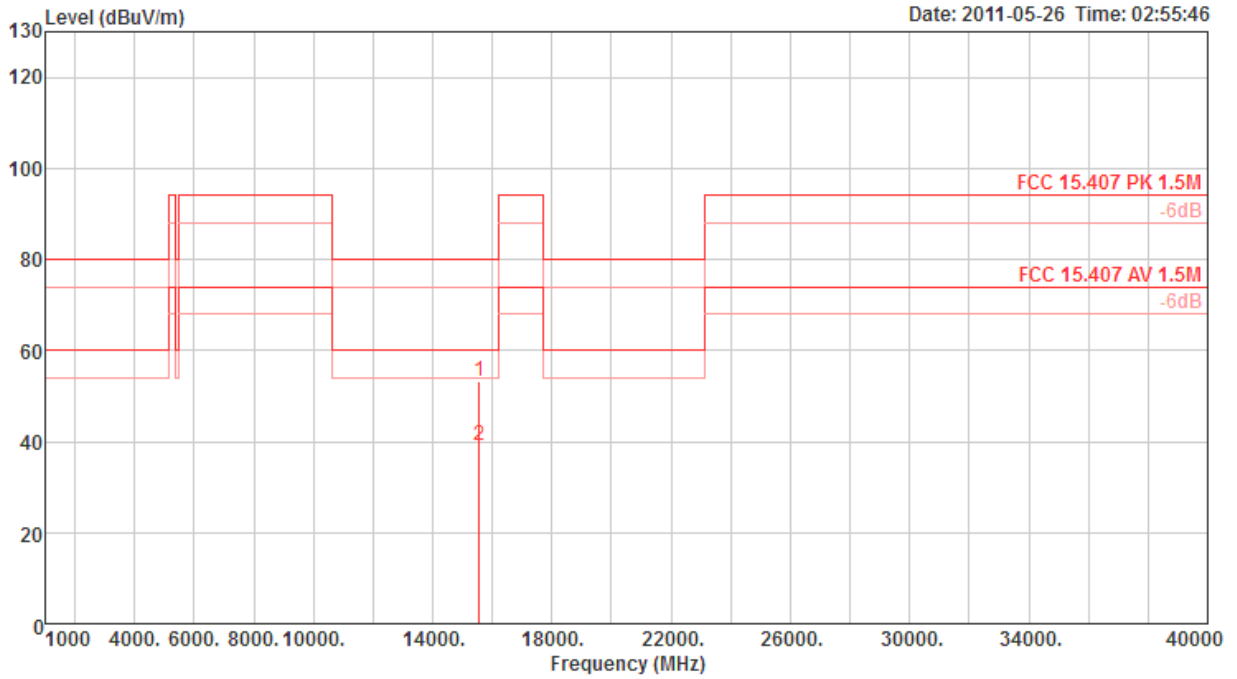

	Freq	Level	Limit Line	Over Limit	Read Level	Cable Loss	Preamp Factor	Antenna Factor	T/Pos	A/Pos	Remark	Pol/Phase
	MHz	dBuV/m	dBuV/m	dB	dBuV	dB	dB	dB/m	deg	cm		
1 p	15567.83	53.17	80.00	-26.83	43.51	6.11	34.72	38.27	89	100	Peak	VERTICAL
2 a	15569.18	39.13	60.00	-20.87	29.47	6.11	34.72	38.27	89	100	Average	VERTICAL



<b>Temperature</b>	24°C	<b>Humidity</b>	60%
<b>Test Engineer</b>	Benson Peng	<b>Configurations</b>	IEEE 802.11n (2TX/2RX) MCS0 40MHz Ch 46 / Mode 1 / Ant. 3 + Ant. 4

**Horizontal**

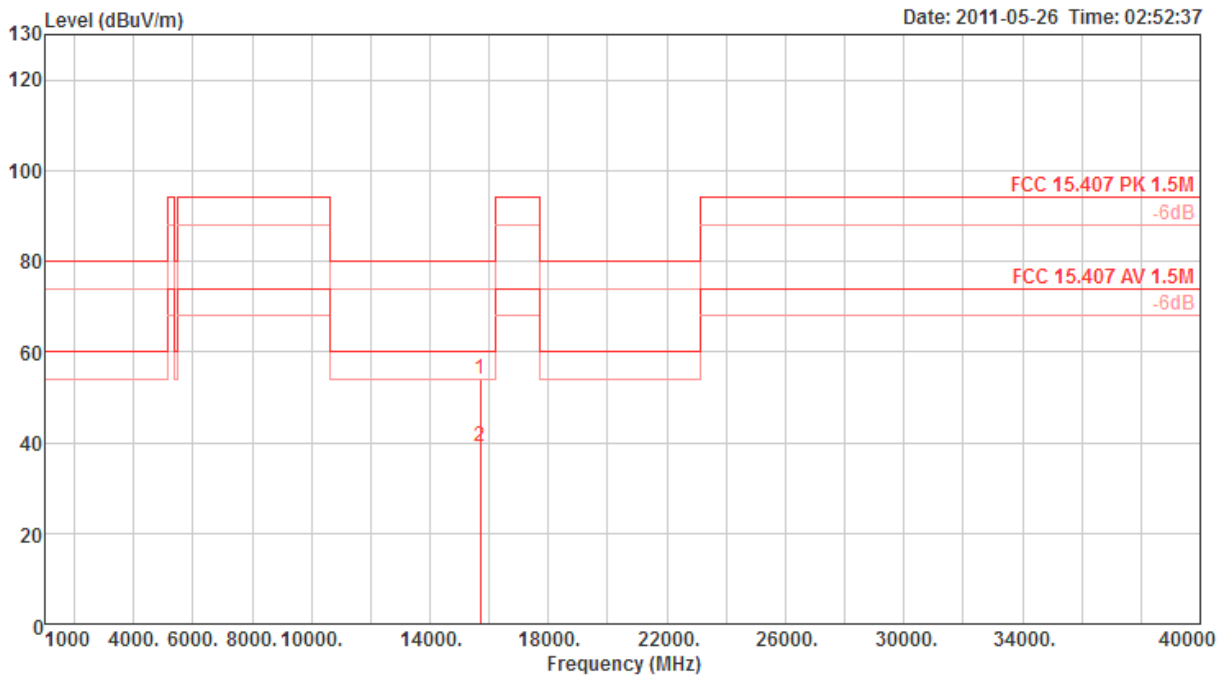

	Freq	Level	Limit	Over	Read	Cable	Preamp	Antenna	T/Pos	A/Pos	Remark	Pol/Phase
	MHz	dBuV/m	dBuV/m	dB	dBuV	dB	dB	dB/m	deg	cm		
1 p	15689.62	53.89	80.00	-26.11	44.23	6.11	34.84	38.39	152	100	Peak	HORIZONTAL
2 a	15690.63	39.20	60.00	-20.80	29.54	6.11	34.84	38.39	152	100	Average	HORIZONTAL

**Vertical**

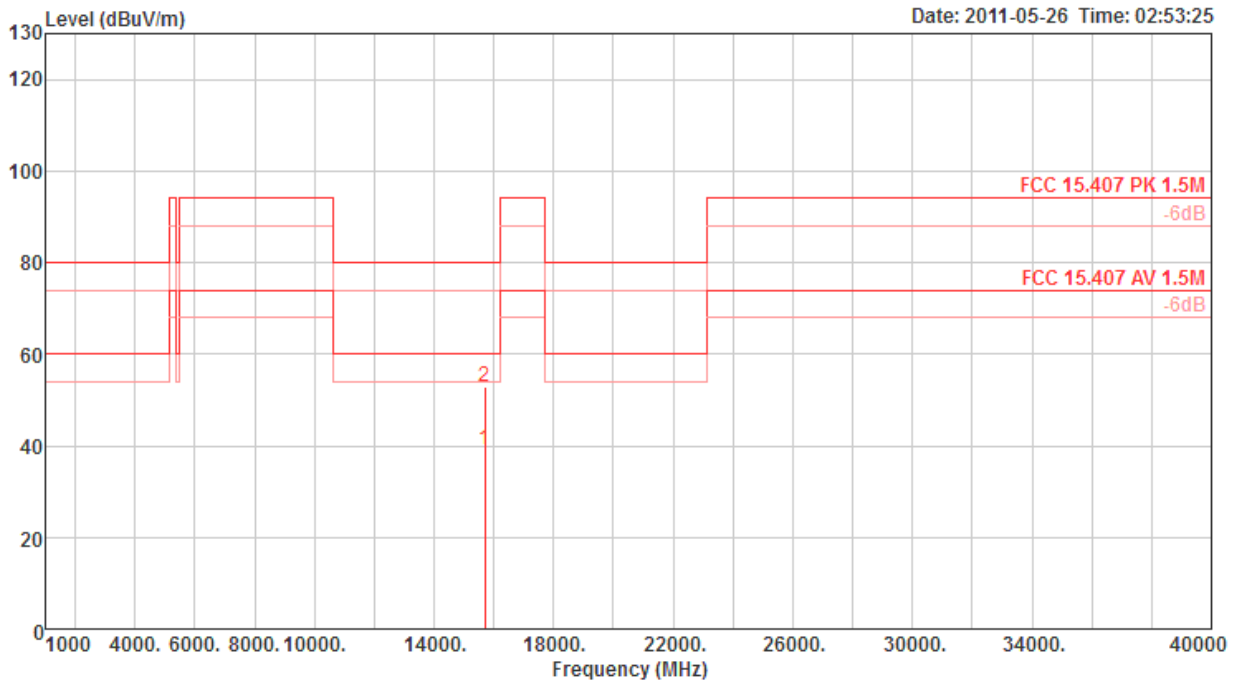

	Freq	Level	Limit	Over	Read	Cable	Preamp	Antenna	T/Pos	A/Pos	Remark	Pol/Phase
	MHz	dBuV/m	dBuV/m	dB	dBuV	dB	dB	dB/m	deg	cm		
1 a	15687.73	39.16	60.00	-20.84	29.50	6.11	34.84	38.39	124	100	Average	VERTICAL
2 p	15690.18	52.97	80.00	-27.03	43.31	6.11	34.84	38.39	124	100	Peak	VERTICAL

Note: The amplitude of spurious emissions that are attenuated by more than 20dB below the permissible value has no need to be reported.

Emission level (dBuV/m) = 20 log Emission level (uV/m).

Corrected Reading: Antenna Factor + Cable Loss + Read Level - Preamp Factor = Level.

The limits above 5GHz shall be extrapolated to the specified distance using an extrapolation factor of 20 dB/decade from 3m to 1.5m.

Distance extrapolation factor = 20 log (specific distance [3m] / test distance [1.5m]) (dB);

Limit line = specific limits (dBuV) + distance extrapolation factor [6 dB].

<IEEE 802.11n (1TX/1RX)>

Temperature	24°C	Humidity	60%
Test Engineer	Sean Ku	Configurations	IEEE 802.11n (1TX/1RX) MCS0 20MHz Ch 36 / Mode 1 / Ant. 3 + Ant. 4

Horizontal

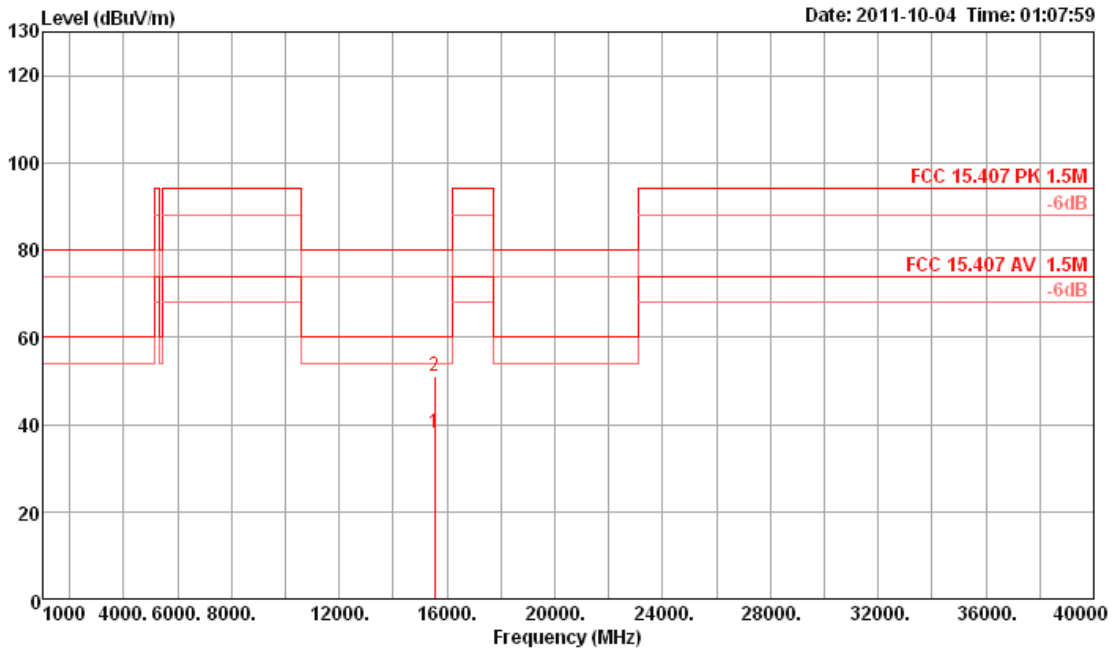

	Freq	Level	Limit Line	Over Limit	Read Level	Cable Loss	Antenna Factor	Preamp Factor	T/Pos	A/Pos	Remark	PoI/Phase
	MHz	dBuV/m	dBuV/m	dB	dBuV	dB	dB/m	dB	deg	cm		
1	15539.59	37.96	60.00	-22.04	29.49	6.13	37.65	35.31	182	100	Average	HORIZONTAL
2	15540.90	50.89	80.00	-29.11	42.42	6.13	37.65	35.31	182	100	Peak	HORIZONTAL

**Vertical**

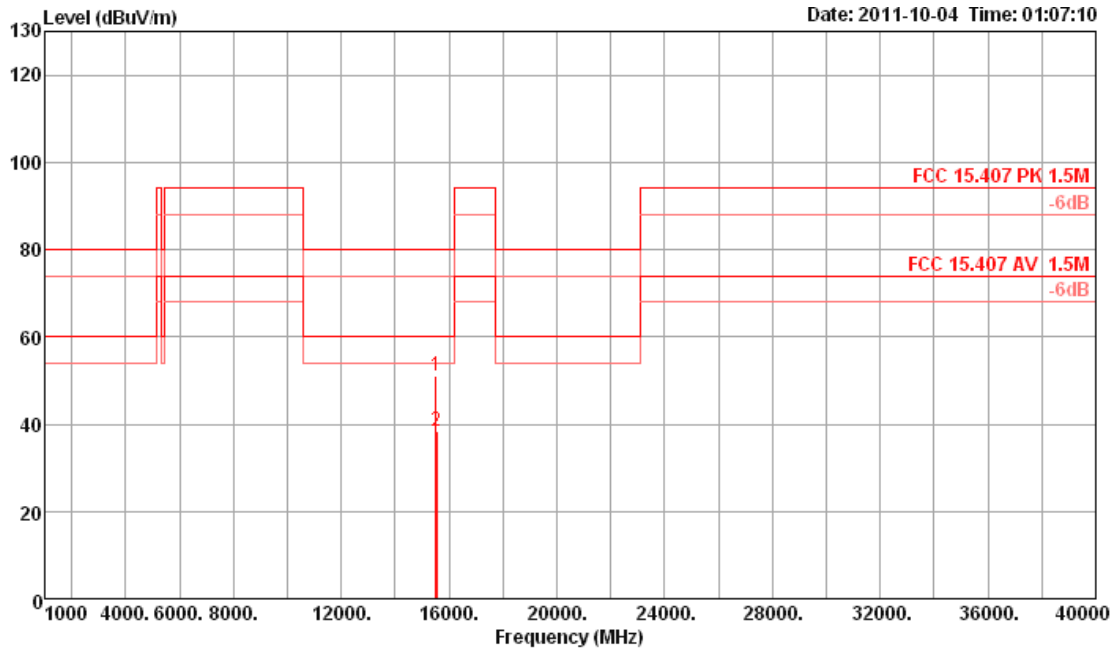

	Freq	Level	Limit Line	Over Limit	Read Level	CableAntenna Loss	Preamp Factor	T/Pos	A/Pos	Remark	Pol/Phase
	MHz	dBuV/m	dBuV/m	dB	dBuV	dB	dB/m	dB	deg	cm	
1	15521.57	51.14	80.00	-28.86	42.57	6.13	37.73	35.29	281	100 Peak	VERTICAL
2	15535.51	38.44	60.00	-21.56	29.87	6.13	37.73	35.29	281	100 Average	VERTICAL



Temperature	24°C	Humidity	60%
Test Engineer	Sean Ku	Configurations	IEEE 802.11n (1TX/1RX) MCS0 20MHz Ch 40 / Mode 1 / Ant. 3

**Horizontal**

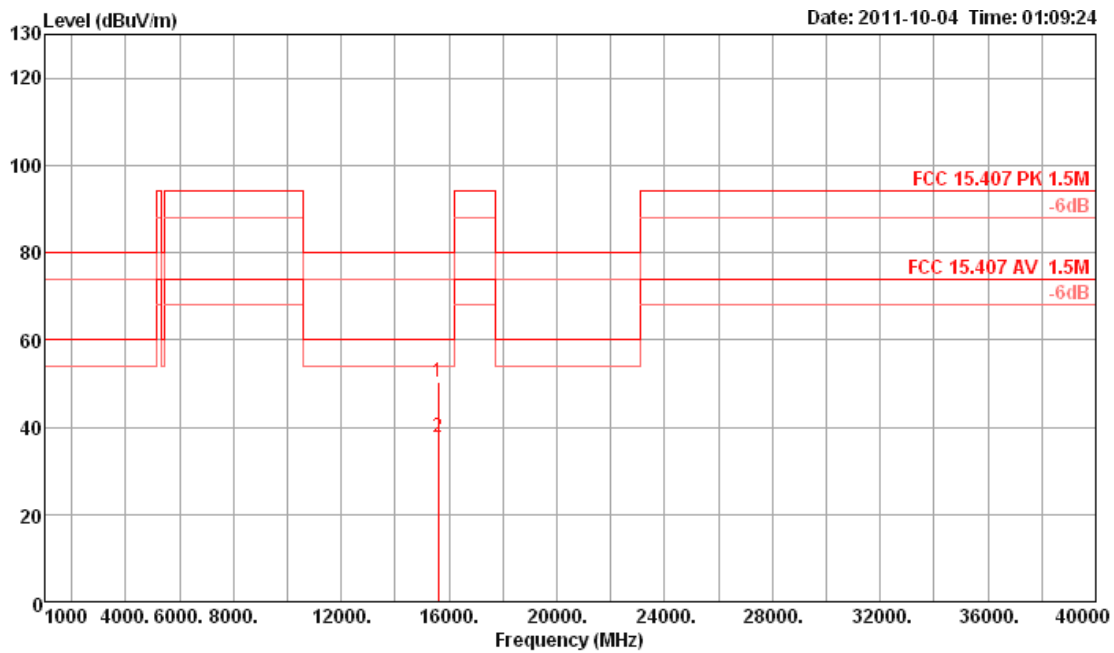

	Freq	Level	Limit Line	Over Limit	Read Level	Cable Loss	Antenna Factor	Preamp Factor	T/Pos	A/Pos	Remark	PoI/Phase
	MHz	dBuV/m	dBuV/m	dB	dBuV	dB	dB/m	dB	deg	cm		
1	15599.12	50.30	80.00	-29.70	41.91	6.13	37.60	35.34	275	100	Peak	HORIZONTAL
2	15599.92	37.82	60.00	-22.18	29.43	6.13	37.60	35.34	275	100	Average	HORIZONTAL

**Vertical**

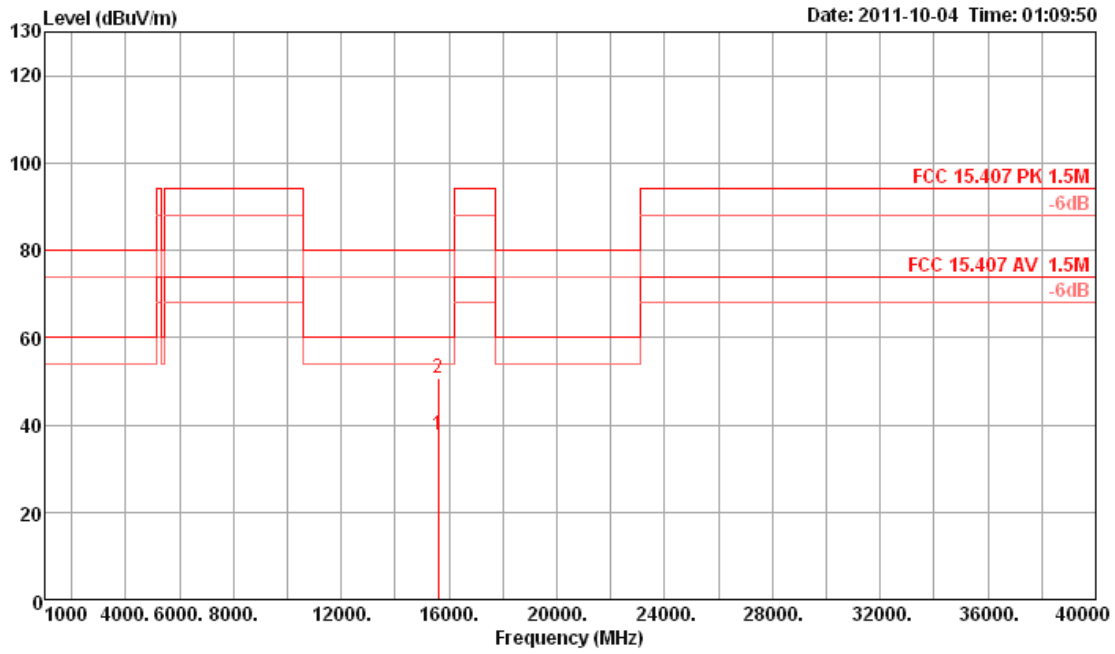

	Freq	Level	Limit Line	Over Limit	Read Level	CableAntenna Loss	Preamp Factor	T/Pos	A/Pos	Remark	Pol/Phase
	MHz	dBuV/m	dBuV/m	dB	dBuV	dB	dB/m	dB	deg	cm	
1	15599.74	37.80	60.00	-22.20	29.41	6.13	37.60	35.34	175	100 Average	VERTICAL
2	15600.15	50.52	80.00	-29.48	42.13	6.13	37.60	35.34	175	100 Peak	VERTICAL



<b>Temperature</b>	24°C	<b>Humidity</b>	60%
<b>Test Engineer</b>	Sean Ku	<b>Configurations</b>	IEEE 802.11n (1TX/1RX) MCS0 20MHz Ch 48 / Mode 1 / Ant. 3

**Horizontal**

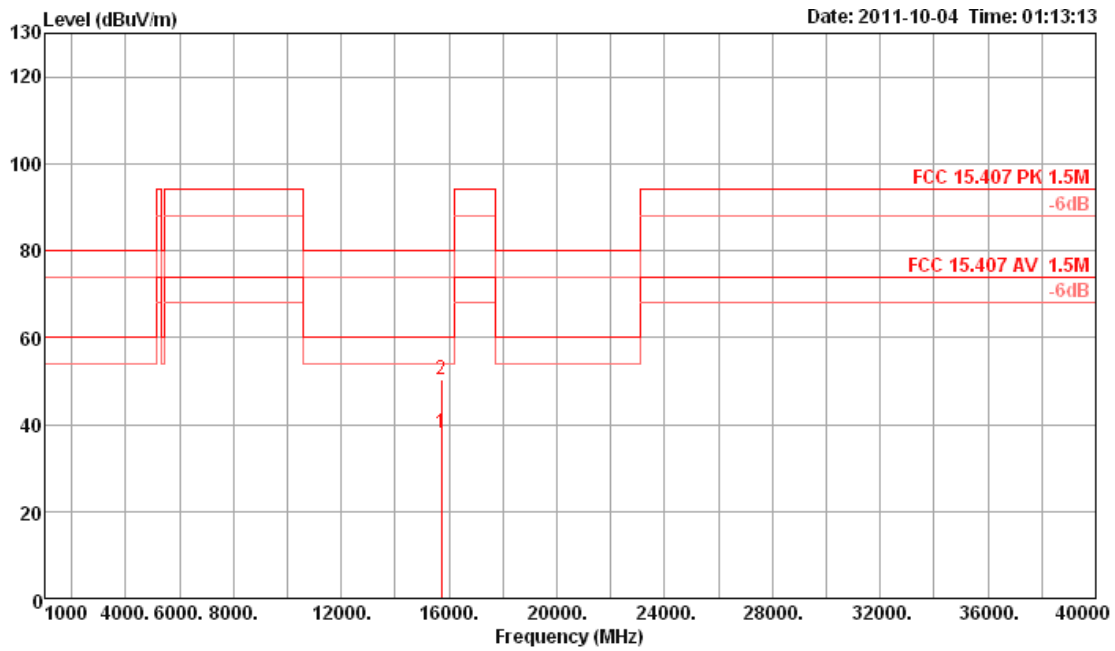

	Freq	Level	Limit Line	Over Limit	Read Level	CableAntenna Loss	Preamp Factor	T/Pos	A/Pos	Remark	PoI/Phase
	MHz	dBuV/m	dBuV/m	dB	dBuV	dB	dB/m	dB	deg	cm	
1	15719.78	38.00	60.00	-22.00	29.77	6.14	37.48	35.39	210	100 Average	HORIZONTAL
2	15720.08	50.45	80.00	-29.55	42.22	6.14	37.48	35.39	210	100 Peak	HORIZONTAL



**Vertical**

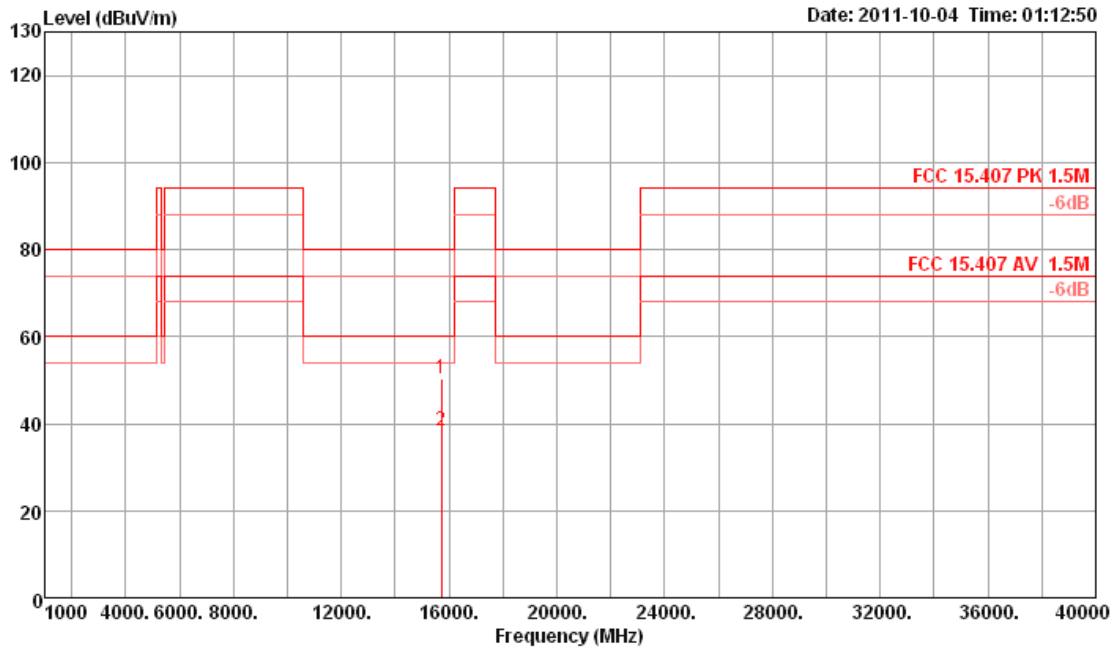

	Freq	Level	Limit Line	Over Limit	Read Level	CableAntenna Loss	Preamp Factor	T/Pos	A/Pos	Remark	Pol/Phase
	MHz	dBuV/m	dBuV/m	dB	dBuV	dB	dB/m	dB	deg	cm	
1	15720.17	50.26	80.00	-29.74	42.03	6.14	37.48	35.39	265	100 Peak	VERTICAL
2	15720.33	38.26	60.00	-21.74	30.03	6.14	37.48	35.39	265	100 Average	VERTICAL



Temperature	24°C	Humidity	60%
Test Engineer	Sean Ku	Configurations	IEEE 802.11n (1TX/1RX) MCS0 40MHz Ch 38 / Mode 1 / Ant. 3

**Horizontal**

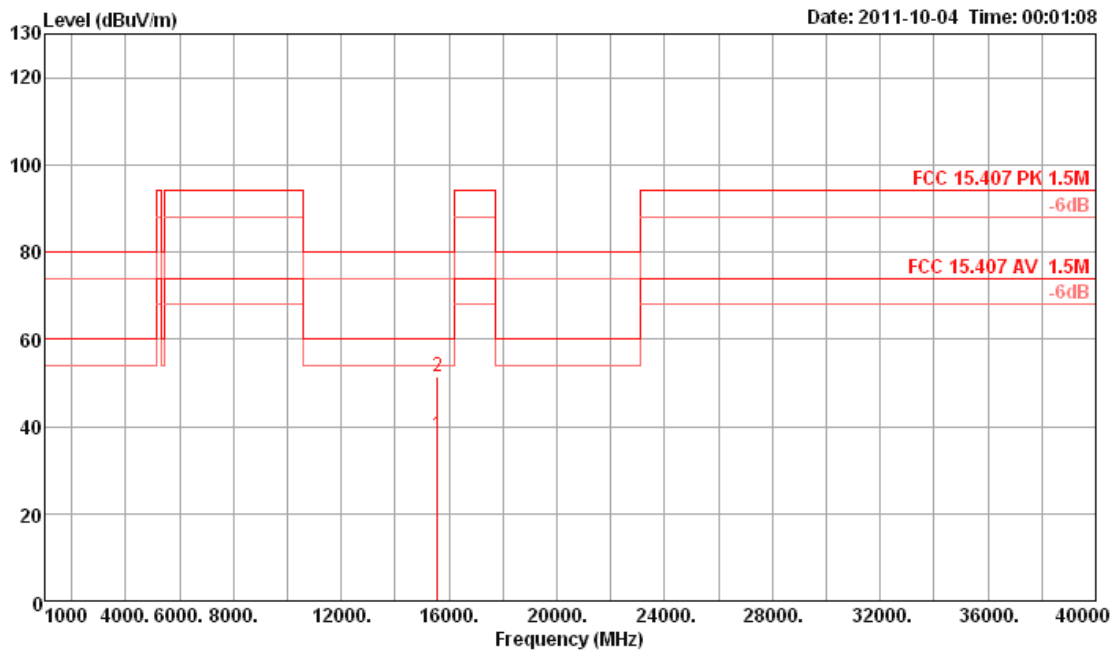

	Freq	Level	Limit Line	Over Limit	Read Level	Cable Loss	Antenna Factor	Preamp Factor	T/Pos	A/Pos	Remark	PoI/Phase
	MHz	dBuV/m	dBuV/m	dB	dBuV	dB	dB/m	dB	deg	cm		
1	15569.98	38.20	60.00	-21.80	29.77	6.13	37.63	35.33	279	100	Average	HORIZONTAL
2	15570.00	51.39	80.00	-28.61	42.96	6.13	37.63	35.33	279	100	Peak	HORIZONTAL

**Vertical**

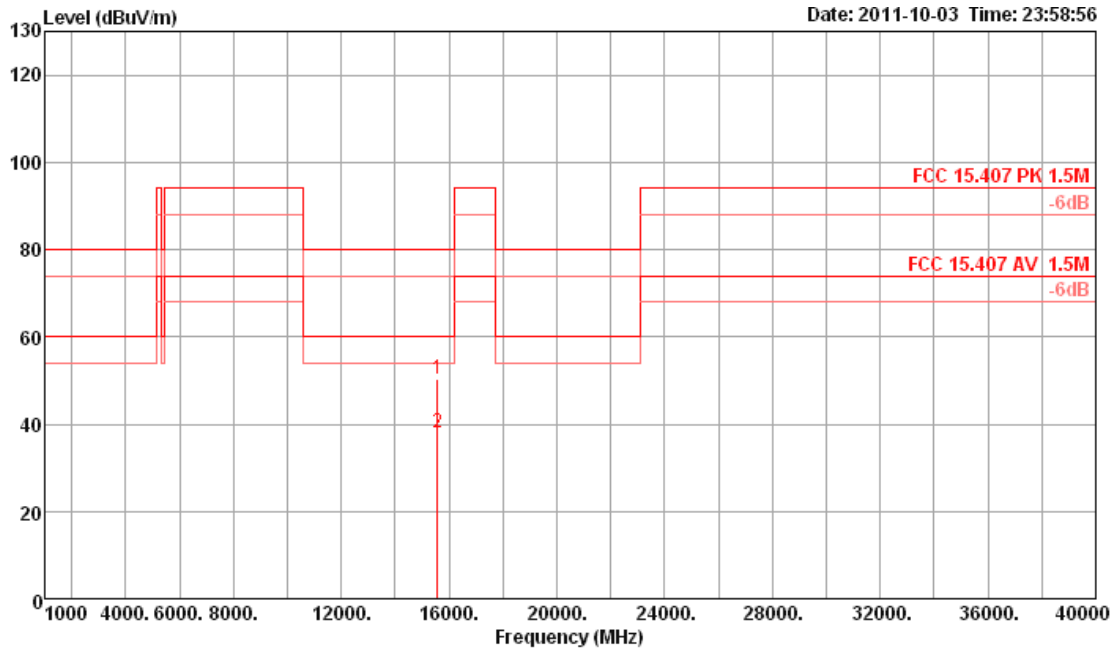

	Freq	Level	Limit Line	Over Limit	Read Level	CableAntenna Loss	Preamp Factor	T/Pos	A/Pos	Remark	Pol/Phase
	MHz	dBuV/m	dBuV/m	dB	dBuV	dB	dB/m	dB	deg	cm	
1	15570.01	50.48	80.00	-29.52	42.03	6.13	37.65	35.33	231	100 Peak	VERTICAL
2	15570.02	37.92	60.00	-22.08	29.47	6.13	37.65	35.33	231	100 Average	VERTICAL



<b>Temperature</b>	24°C	<b>Humidity</b>	60%
<b>Test Engineer</b>	Sean Ku	<b>Configurations</b>	IEEE 802.11n (1TX/1RX) MCS0 40MHz Ch 46 / Mode 1 / Ant. 3

**Horizontal**

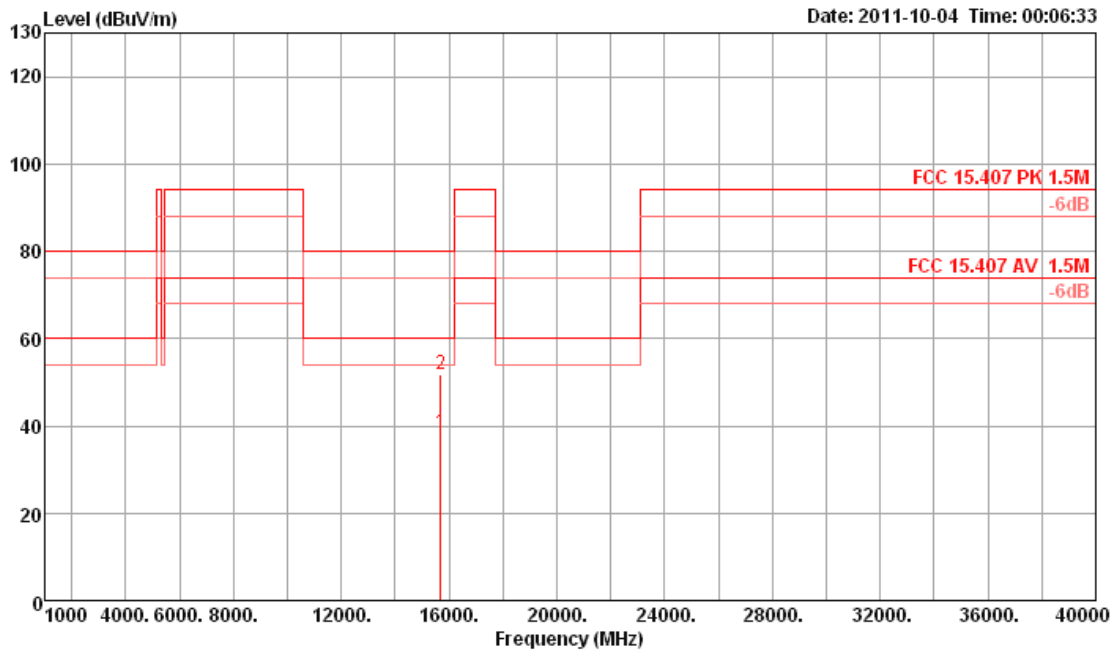

	Freq	Level	Limit Line	Over Limit	Read Level	Cable Loss	Antenna Factor	Preamp Factor	T/Pos	A/Pos	Remark	Pol/Phase
	MHz	dBuV/m	dBuV/m	dB	dBuV	dB	dB/m	dB	deg	cm		
1	15689.99	38.31	60.00	-21.69	30.03	6.14	37.51	35.37	161	100	Average	HORIZONTAL
2	15690.00	51.84	80.00	-28.16	43.56	6.14	37.51	35.37	161	100	Peak	HORIZONTAL

**Vertical**

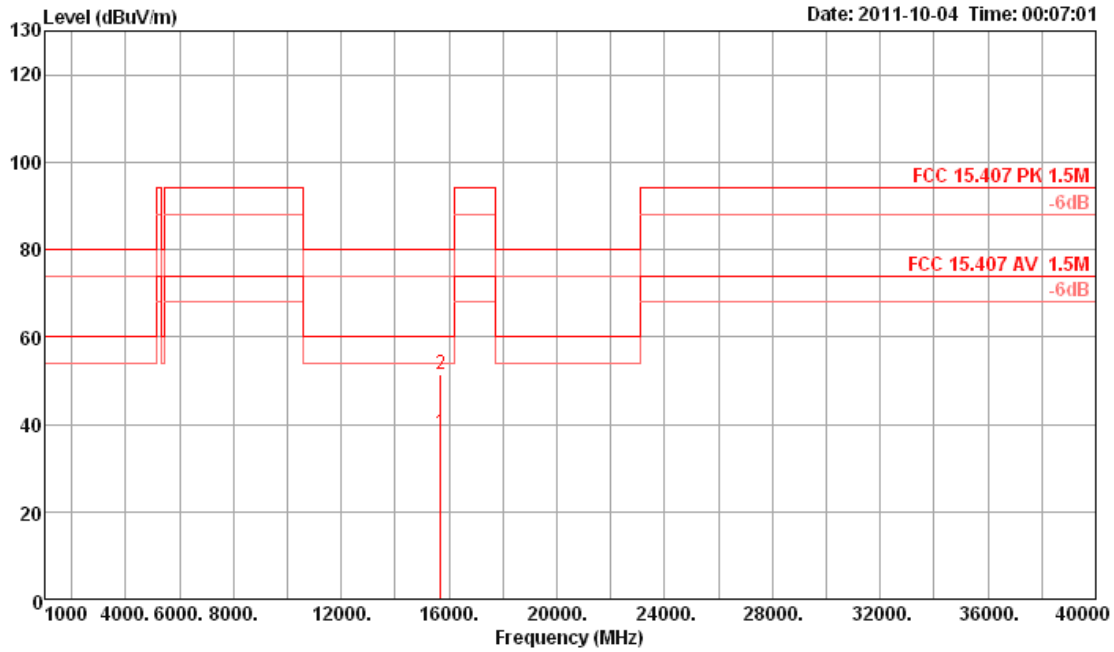

	Freq	Level	Limit Line	Over Limit	Read Level	CableAntenna Loss	Preamp Factor	T/Pos	A/Pos	Remark	PoI/Phase
	MHz	dBuV/m	dBuV/m	dB	dBuV	dB	dB/m	dB	deg	cm	
1	15689.99	38.14	60.00	-21.86	29.86	6.14	37.51	35.37	307	100 Average	VERTICAL
2	15690.00	51.54	80.00	-28.46	43.26	6.14	37.51	35.37	356	100 Peak	VERTICAL

Note: The amplitude of spurious emissions that are attenuated by more than 20dB below the permissible value has no need to be reported.

Emission level (dBuV/m) = 20 log Emission level (uV/m).

Corrected Reading: Antenna Factor + Cable Loss + Read Level - Preamp Factor = Level.

The limits above 5GHz shall be extrapolated to the specified distance using an extrapolation factor of 20 dB/decade from 3m to 1.5m.

Distance extrapolation factor = 20 log (specific distance [3m] / test distance [1.5m]) (dB);

Limit line = specific limits (dBuV) + distance extrapolation factor [6 dB].

<IEEE 802.11a (1TX/1RX)>

<b>Temperature</b>	24°C	<b>Humidity</b>	60%
<b>Test Engineer</b>	Benson Peng	<b>Configurations</b>	IEEE 802.11a (1TX/1RX) Ch 36 / Mode 1 / Ant. 4

**Horizontal**

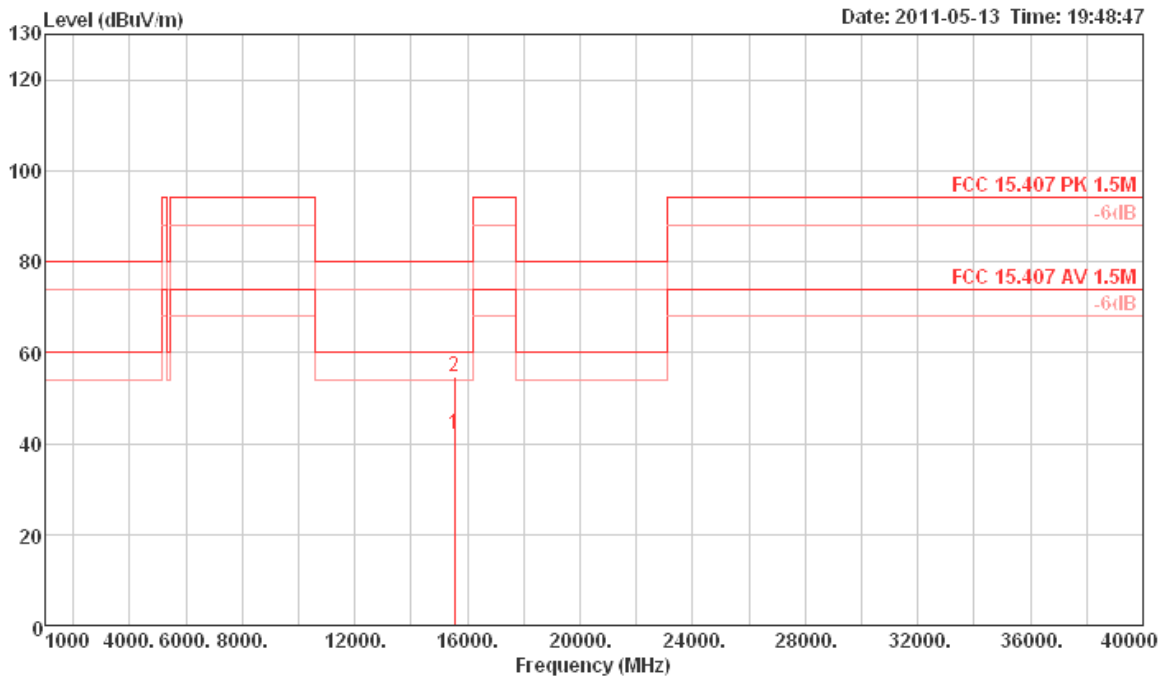

	Freq	Level	Limit	Over	Read	CableAntenna	Preamp	Remark	Pol/Phase
	MHz	dBuV/m	dBuV/m	dB	dBuV	dB	dB/m	dB	
1	15537.60	42.15	60.00	-17.85	31.33	8.26	38.15	35.59 Average	HORIZONTAL
2	15537.98	54.77	80.00	-25.23	43.98	8.26	38.12	35.59 Peak	HORIZONTAL

**Vertical**

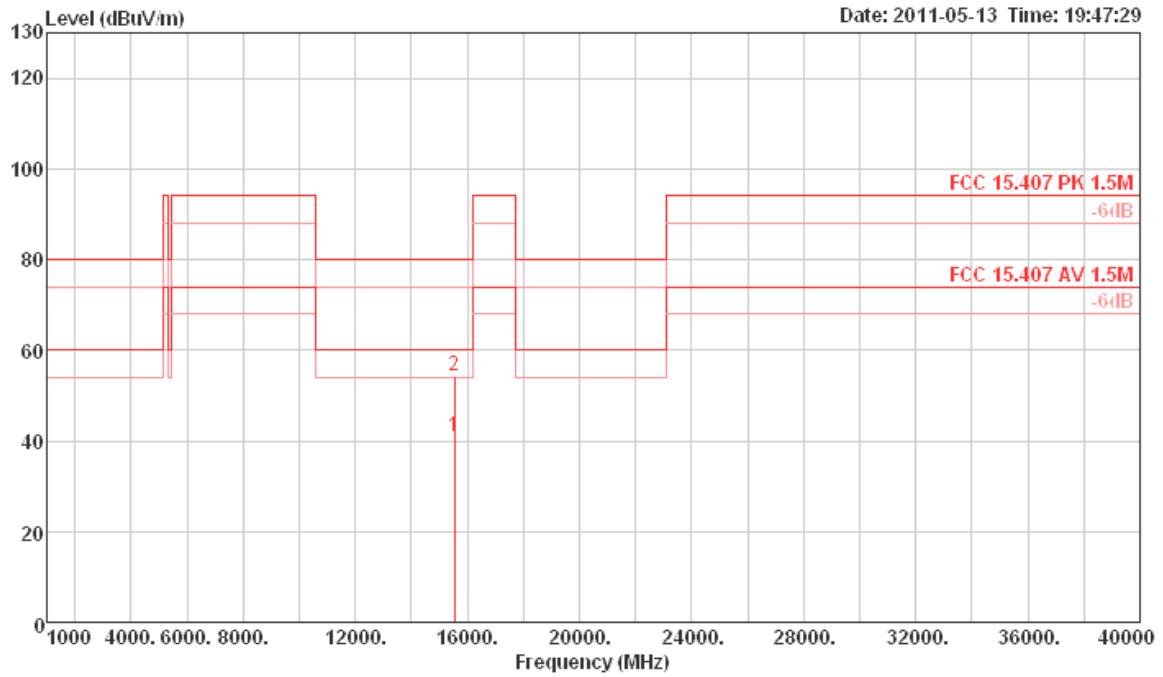

	Freq	Level	Limit Line	Over Limit	Read Level	CableAntenna Loss	Preamp Factor	Preamp Factor	Remark	Pol/Phase
	MHz	dBuV/m	dBuV/m	dB	dBuV	dB	dB/m	dB		
1	15539.87	41.09	60.00	-18.91	30.30	8.26	38.12	35.59	Average	VERTICAL
2	15541.88	54.37	80.00	-25.63	43.58	8.26	38.12	35.59	Peak	VERTICAL

<b>Temperature</b>	24°C	<b>Humidity</b>	60%
<b>Test Engineer</b>	Benson Peng	<b>Configurations</b>	IEEE 802.11a (1TX/1RX) Ch 40 / Mode 1 / Ant. 4

**Horizontal**

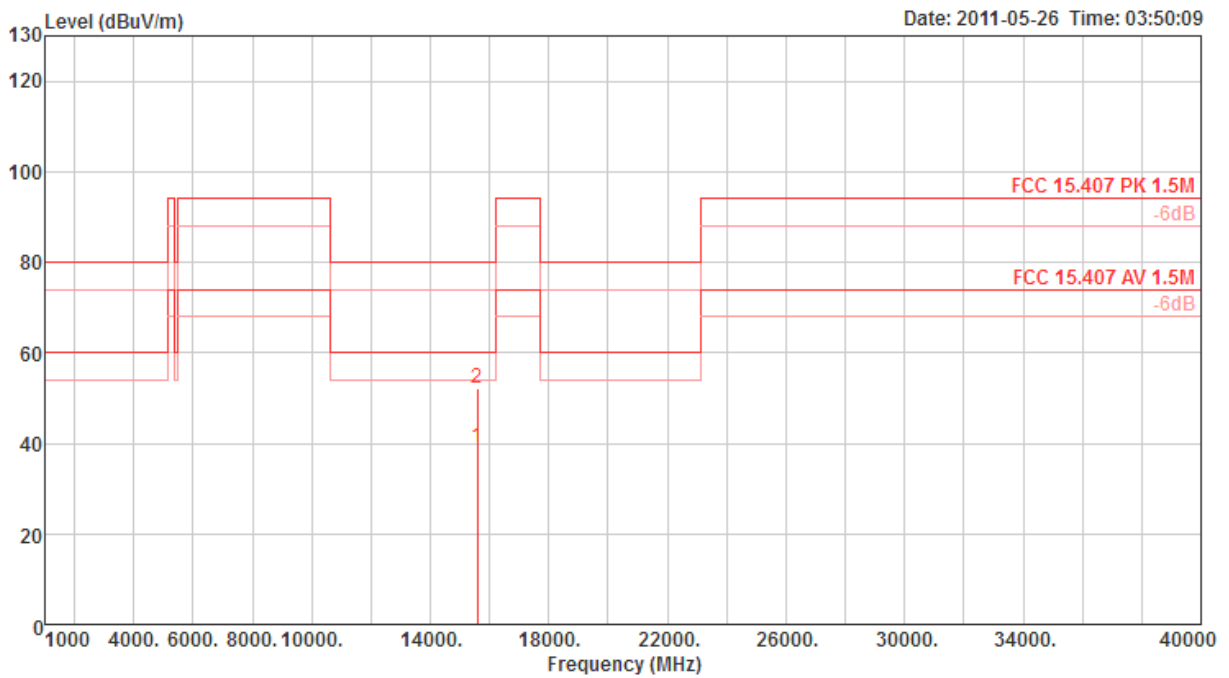

	Freq	Level	Limit	Over	Read	Cable	Preamp	Antenna	T/Pos	A/Pos	Remark	Pol/Phase
	MHz	dBUV/m	dBUV/m	dB	dBuV	dB	dB	dB/m	deg	cm		
1 a	15598.32	39.24	60.00	-20.76	29.57	6.11	34.74	38.30	139	100	Average	HORIZONTAL
2 p	15598.61	52.29	80.00	-27.71	42.62	6.11	34.74	38.30	139	100	Peak	HORIZONTAL



**Vertical**

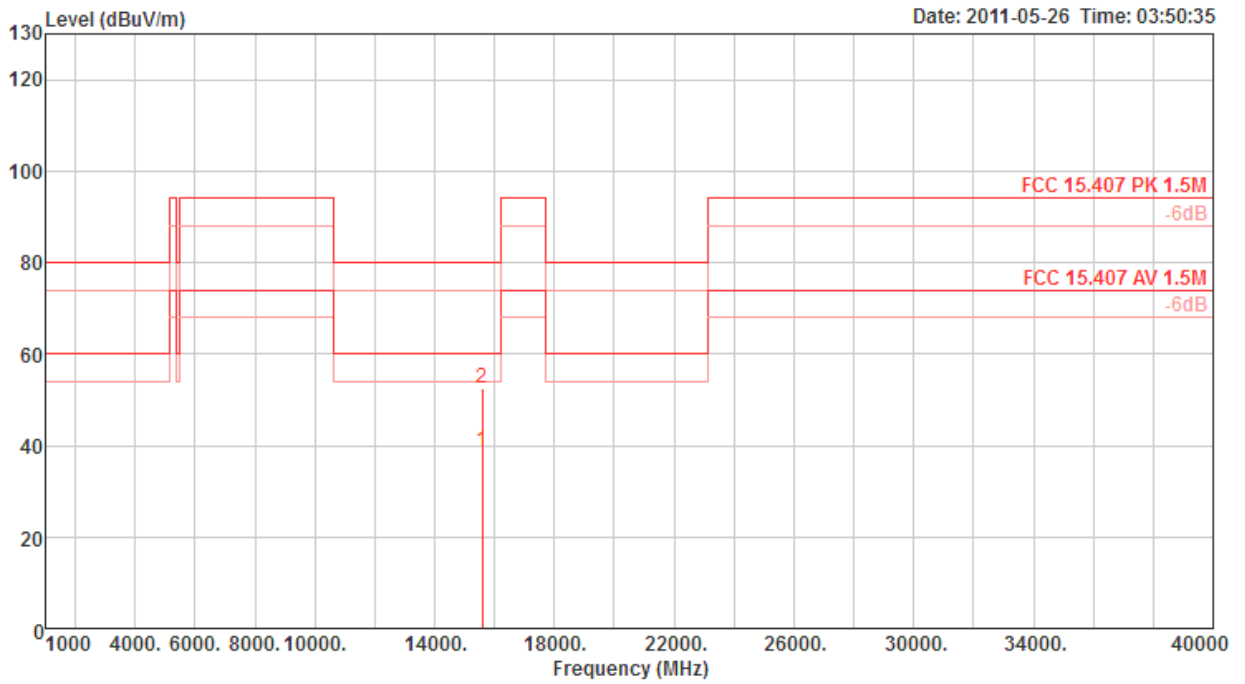

	Freq	Level	Limit	Over	Read	Cable	Preamp	Antenna	T/Pos	A/Pos	Remark	Pol/Phase
	MHz	dBuV/m	dBuV/m	dB	dBuV	dB	dB	dB/m	deg	cm		
1 a	15599.79	38.92	60.00	-21.08	29.28	6.11	34.77	38.30	100	100	Average	VERTICAL
2 p	15600.73	52.41	80.00	-27.59	42.77	6.11	34.77	38.30	100	100	Peak	VERTICAL

<b>Temperature</b>	24°C	<b>Humidity</b>	60%
<b>Test Engineer</b>	Benson Peng	<b>Configurations</b>	IEEE 802.11a (1TX/1RX) Ch 48 / Mode 1 / Ant. 4

**Horizontal**

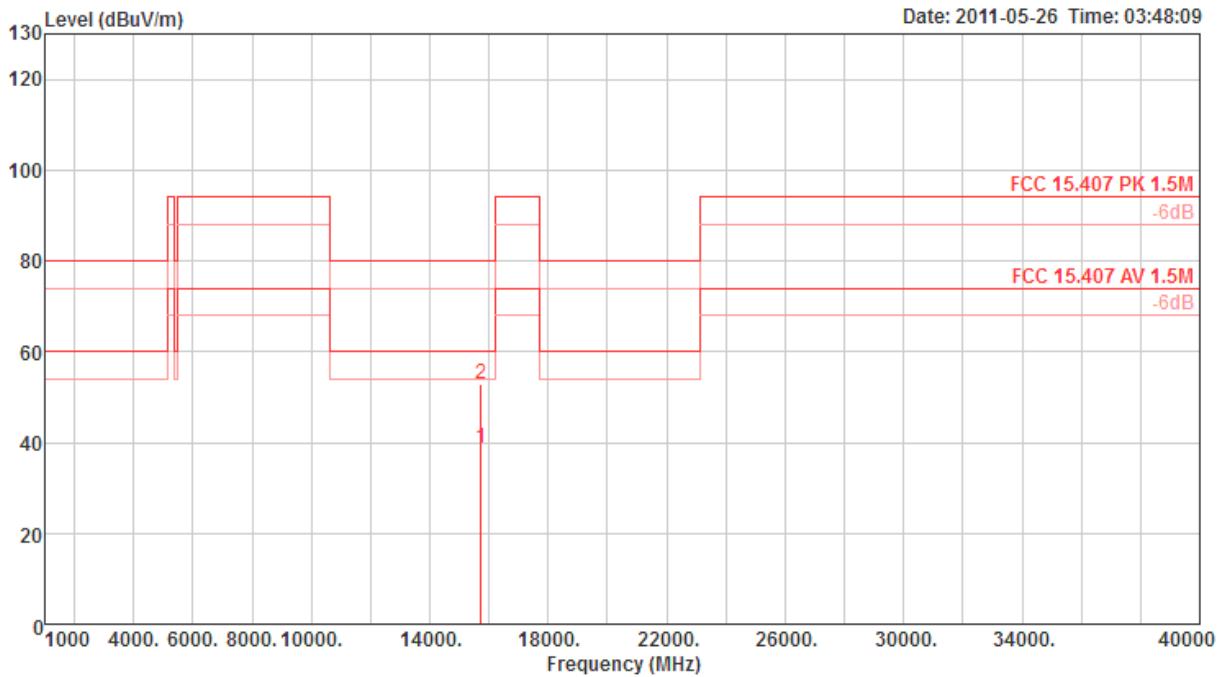

	Freq	Level	Limit	Over	Read	Cable	Preamp	Antenna	T/Pos	A/Pos	Remark	Pol/Phase
	MHz	dBuV/m	dBuV/m	dB	dBuV	dB	dB	dB/m	deg	cm		
1 a	15717.50	38.88	60.00	-21.12	29.21	6.11	34.86	38.42	152	100	Average	HORIZONTAL
2 p	15722.25	52.85	80.00	-27.15	43.18	6.11	34.86	38.42	152	100	Peak	HORIZONTAL

**Vertical**

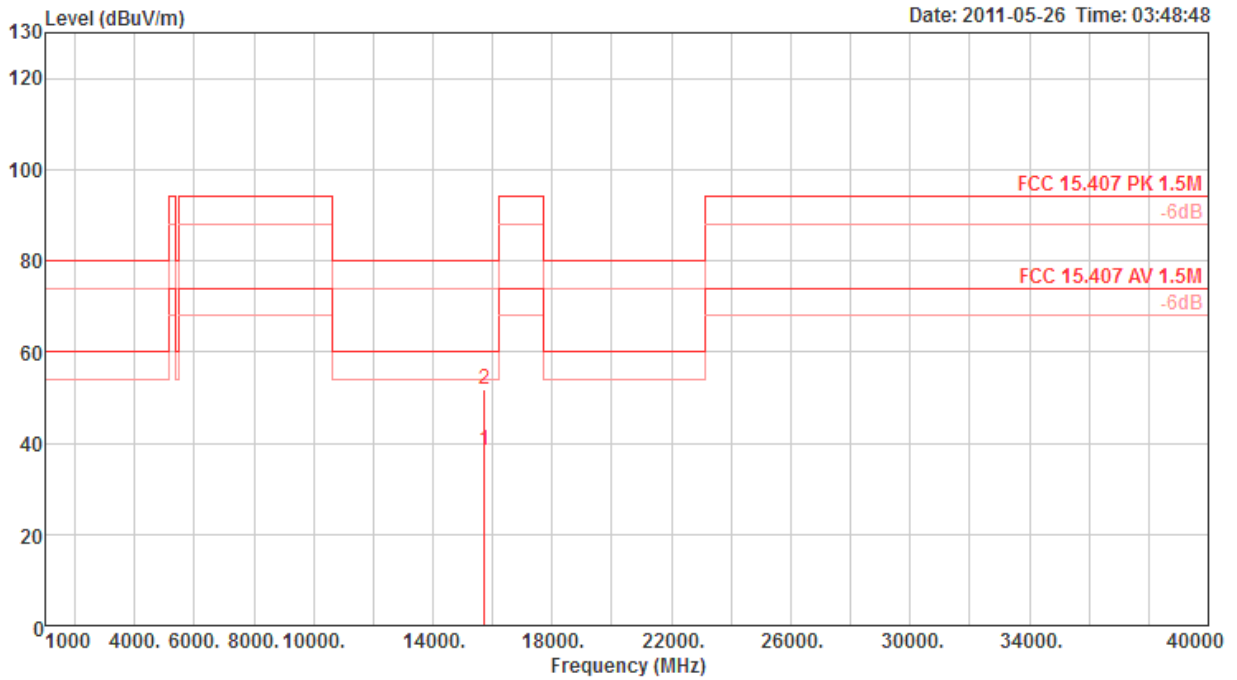

	Freq	Level	Limit	Over	Read	Cable	Preamp	Antenna	T/Pos	A/Pos	Remark	Pol/Phase
	MHz	dBuV/m	dBuV/m	dB	dBuV	dB	dB	dB/m	deg	cm		
1 a	15717.69	38.56	60.00	-21.44	28.89	6.11	34.86	38.42	148	100	Average	VERTICAL
2 p	15717.86	51.94	80.00	-28.06	42.27	6.11	34.86	38.42	148	100	Peak	VERTICAL

Note: The amplitude of spurious emissions that are attenuated by more than 20dB below the permissible value has no need to be reported.

Emission level (dBuV/m) = 20 log Emission level (uV/m).

Corrected Reading: Antenna Factor + Cable Loss + Read Level - Preamp Factor = Level.

The limits above 5GHz shall be extrapolated to the specified distance using an extrapolation factor of 20 dB/decade from 3m to 1.5m.

Distance extrapolation factor = 20 log (specific distance [3m] / test distance [1.5m]) (dB);

Limit line = specific limits (dBuV) + distance extrapolation factor [6 dB].

<IEEE 802.11a (1TX/1RX)>

Temperature	24°C	Humidity	60%
Test Engineer	Sean Ku	Configurations	IEEE 802.11a (1TX/1RX) Ch 36 / Mode 1 / Ant. 3

Horizontal

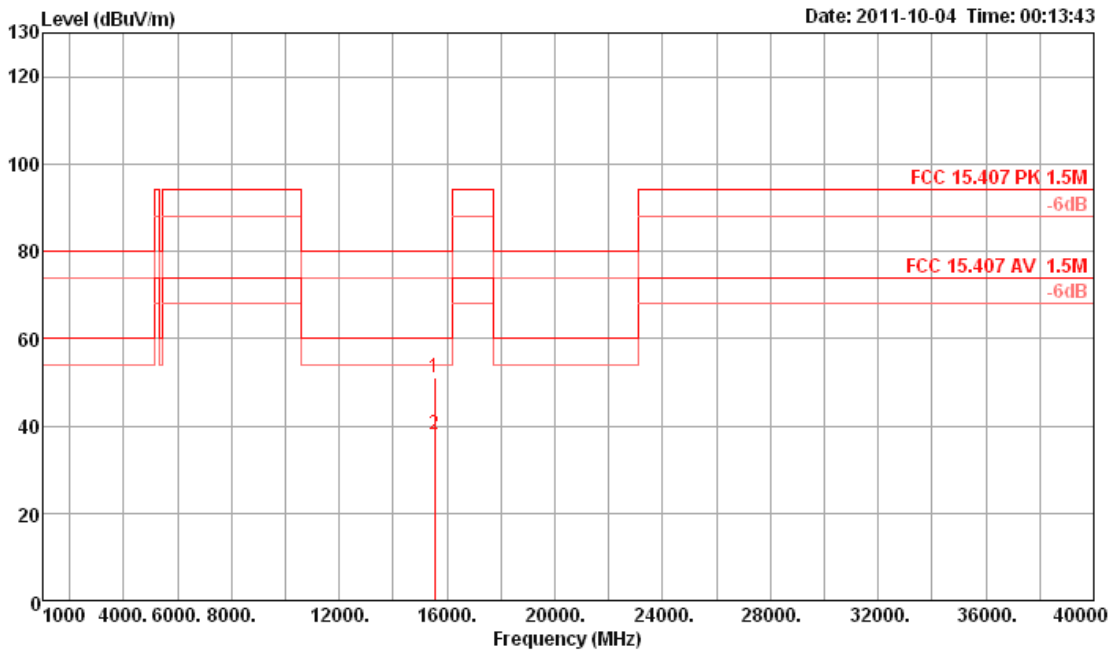

	Freq	Level	Limit Line	Over Limit	Read Level	Cable Loss	Antenna Factor	Preamp Factor	T/Pos	A/Pos	Remark	PoI/Phase
	MHz	dBuV/m	dBuV/m	dB	dBuV	dB	dB/m	dB	deg	cm		
1	15540.00	51.14	80.00	-28.86	42.67	6.13	37.65	35.31	340	100	Peak	HORIZONTAL
2	15540.00	38.05	60.00	-21.95	29.58	6.13	37.65	35.31	340	100	Average	HORIZONTAL

**Vertical**

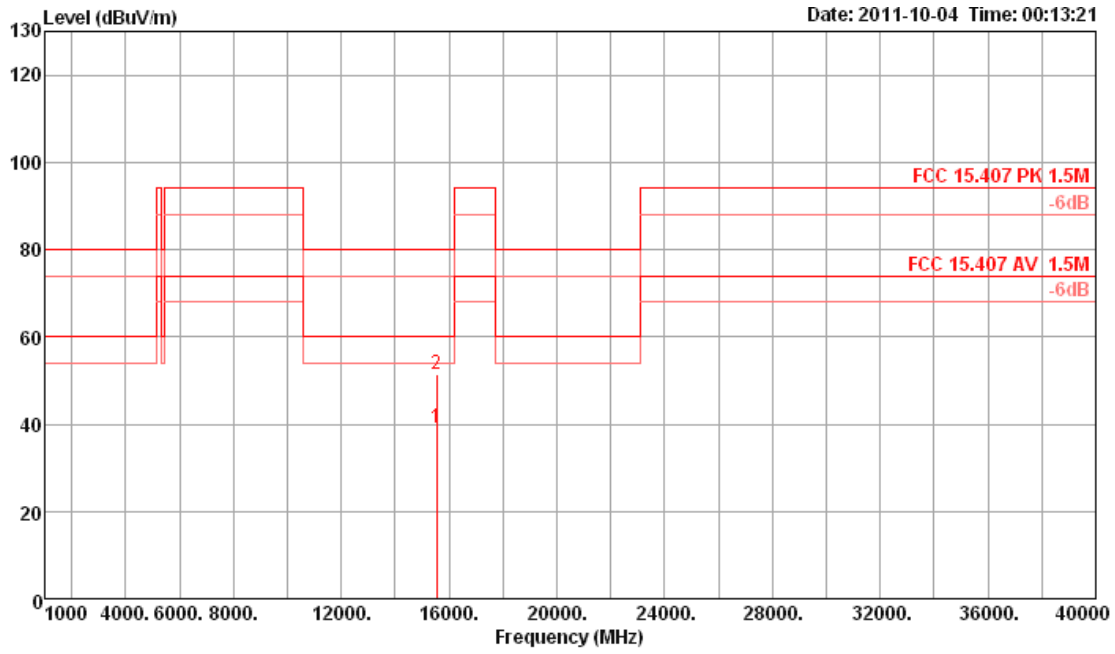

	Freq	Level	Limit Line	Over Limit	Read Level	CableAntenna Loss	Preamp Factor	T/Pos	A/Pos	Remark	Pol/Phase
	MHz	dBuV/m	dBuV/m	dB	dBuV	dB	dB/m	dB	deg	cm	
1	15539.99	38.93	60.00	-21.07	30.42	6.13	37.69	35.31	280	100 Average	VERTICAL
2	15540.00	51.39	80.00	-28.61	42.88	6.13	37.69	35.31	280	100 Peak	VERTICAL



Temperature	24°C	Humidity	60%
Test Engineer	Sean Ku	Configurations	IEEE 802.11a (1TX/1RX) Ch 40 / Mode 1 / Ant. 3

**Horizontal**

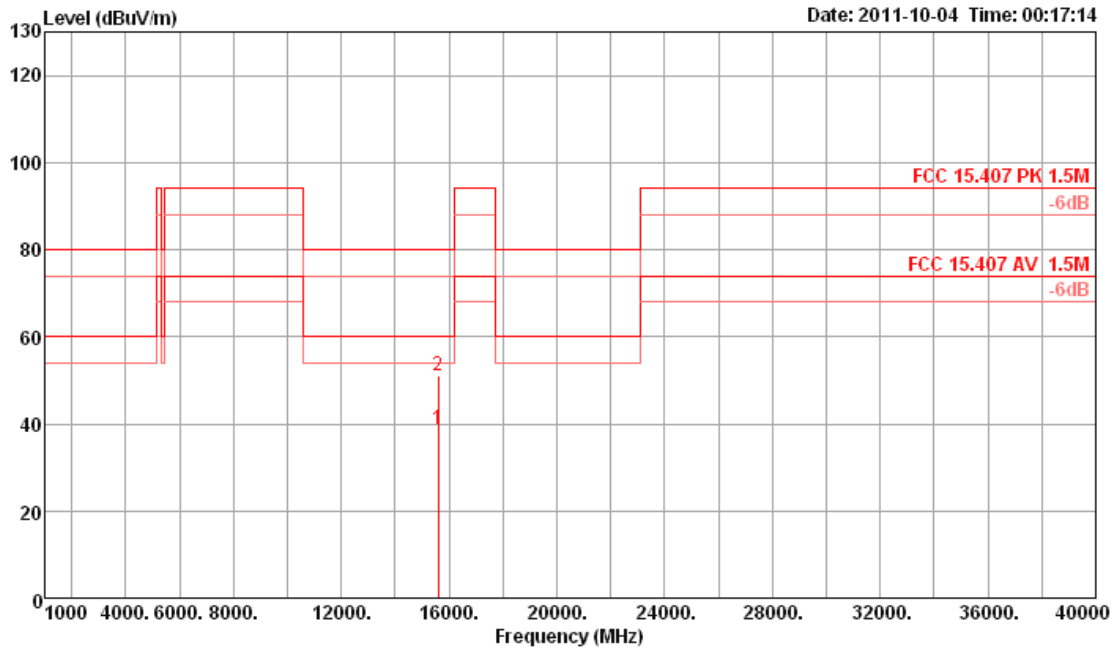

	Freq	Level	Limit Line	Over Limit	Read Level	Cable Loss	Antenna Factor	Preamp Factor	T/Pos	A/Pos	Remark	PoI/Phase
	MHz	dBuV/m	dBuV/m	dB	dBuV	dB	dB/m	dB	deg	cm		
1	15600.00	38.83	60.00	-21.17	30.44	6.13	37.60	35.34	225	100	Average	HORIZONTAL
2	15600.00	51.01	80.00	-28.99	42.62	6.13	37.60	35.34	225	100	Peak	HORIZONTAL

**Vertical**

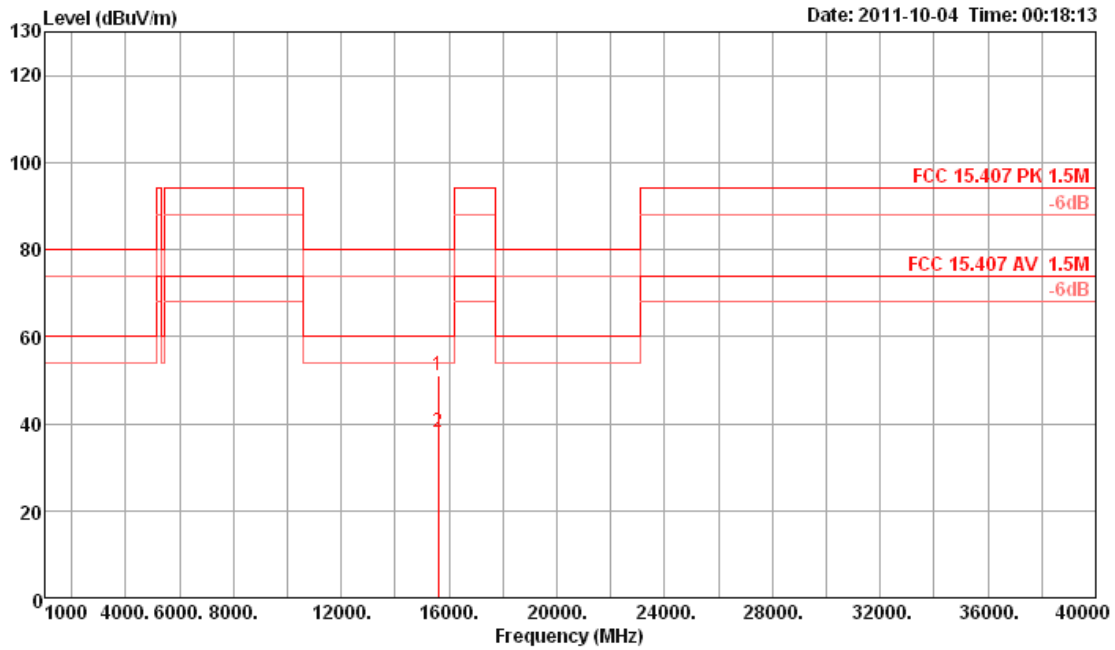

	Freq	Level	Limit Line	Over Limit	Read Level	CableAntenna Loss	Preamp Factor	T/Pos	A/Pos	Remark	Pol/Phase
	MHz	dBuV/m	dBuV/m	dB	dBuV	dB	dB/m	dB	deg	cm	
1	15599.99	50.98	80.00	-29.02	42.59	6.13	37.60	35.34	122	101 Peak	VERTICAL
2	15600.00	38.00	60.00	-22.00	29.61	6.13	37.60	35.34	122	101 Average	VERTICAL



Temperature	24°C	Humidity	60%
Test Engineer	Sean Ku	Configurations	IEEE 802.11a (1TX/1RX) Ch 48 / Mode 1 / Ant. 3

**Horizontal**

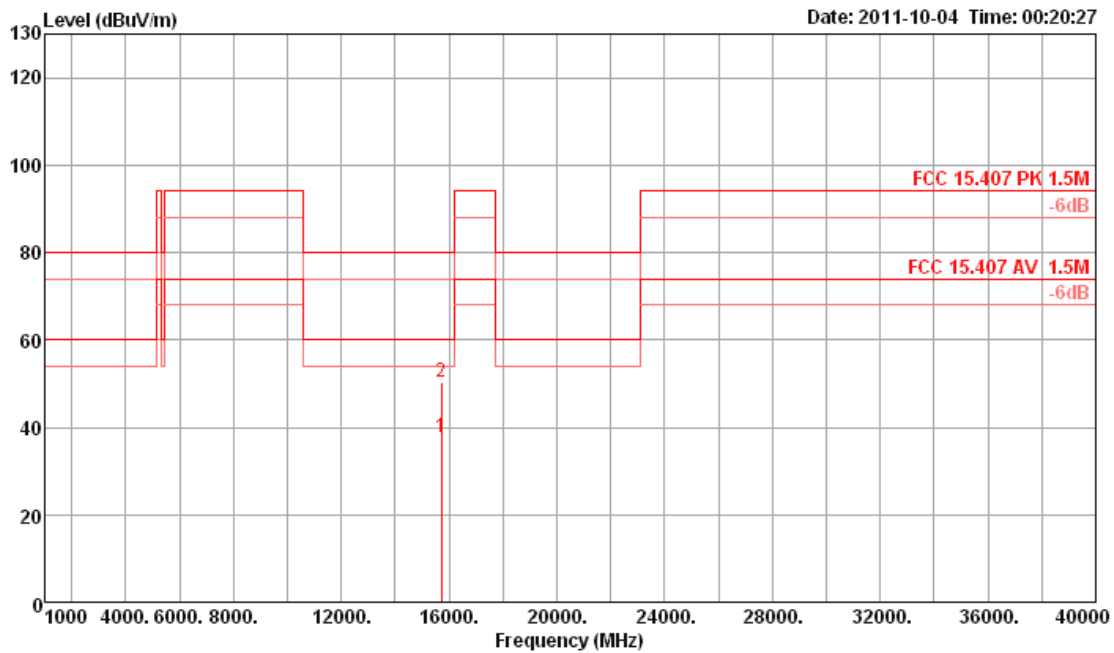

	Freq	Level	Limit Line	Over Limit	Read Level	Cable Loss	Antenna Factor	Preamp Factor	T/Pos	A/Pos	Remark	Pol/Phase
	MHz	dBuV/m	dBuV/m	dB	dBuV	dB	dB/m	dB	deg	cm		
1	15720.00	37.79	60.00	-22.21	29.56	6.14	37.48	35.39	267	100	Average	HORIZONTAL
2	15720.01	50.46	80.00	-29.54	42.23	6.14	37.48	35.39	267	100	Peak	HORIZONTAL



**Vertical**

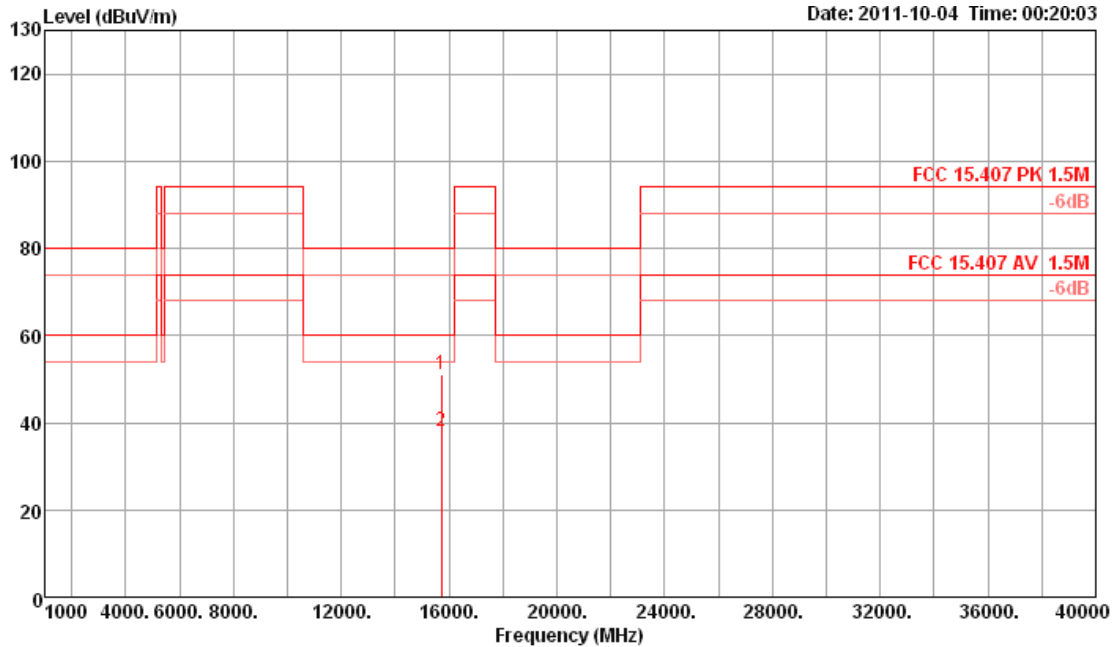

	Freq	Level	Limit Line	Over Limit	Read Level	CableAntenna Loss	Preamp Factor	T/Pos	A/Pos	Remark	Pol/Phase
	MHz	dBuV/m	dBuV/m	dB	dBuV	dB	dB/m	dB	deg	cm	
1	15719.99	51.10	80.00	-28.90	42.87	6.14	37.48	35.39	166	100 Peak	VERTICAL
2	15720.01	37.86	60.00	-22.14	29.63	6.14	37.48	35.39	166	100 Average	VERTICAL

Note: The amplitude of spurious emissions that are attenuated by more than 20dB below the permissible value has no need to be reported.

Emission level (dBuV/m) = 20 log Emission level (uV/m).

Corrected Reading: Antenna Factor + Cable Loss + Read Level - Preamp Factor = Level.

The limits above 5GHz shall be extrapolated to the specified distance using an extrapolation factor of 20 dB/decade from 3m to 1.5m.

Distance extrapolation factor = 20 log (specific distance [3m] / test distance [1.5m]) (dB);

Limit line = specific limits (dBuV) + distance extrapolation factor [6 dB].

## 4.7. Band Edge Emissions Measurement

### 4.7.1. Limit

For transmitters operating in the 5.15-5.25 GHz band: all emissions outside of the 5.15-5.35 GHz band shall not exceed an EIRP of -27 dBm/MHz (68.3dBuV/m at 3m). In addition, In case the emission fall within the restricted band specified on 15.205(a), then the 15.209(a) limit in the table below has to be followed.

Frequencies (MHz)	Field Strength (micorvolts/meter)	Measurement Distance (meters)
0.009~0.490	2400/F(KHz)	300
0.490~1.705	24000/F(KHz)	30
1.705~30.0	30	30
30~88	100	3
88~216	150	3
216~960	200	3
Above 960	500	3

### 4.7.2. Measuring Instruments and Setting

Please refer to section 5 of equipments list in this report. The following table is the setting of the spectrum analyzer.

Spectrum Parameter	Setting
Attenuation	Auto
Span Frequency	100 MHz
RB / VB (Emission in restricted band)	1MHz / 1MHz for Peak, 1 MHz / 10Hz for Average
RB / VB (Emission in non-restricted band)	1 MHz /1 MHz for Peak

### 4.7.3. Test Procedures

1. The test procedure is the same as section 4.6.3, only the frequency range investigated is limited to 100MHz around bandedges.
2. In case the emission is fail due to the used RB/VB is too wide, marker-delta method of FCC Public Notice DA00-705 will be followed.

### 4.7.4. Test Setup Layout

This test setup layout is the same as that shown in section 4.6.4.

### 4.7.5. Test Deviation

There is no deviation with the original standard.

### 4.7.6. EUT Operation during Test

The EUT was programmed to be in continuously transmitting mode.

#### 4.7.7. Test Result of Band Edge and Fundamental Emissions

<IEEE 802.11n (2TX/2RX)>

<b>Temperature</b>	24°C	<b>Humidity</b>	60%
<b>Test Engineer</b>	Benson Peng	<b>Configurations</b>	IEEE 802.11n (2TX/2RX) MCS0 20MHz Ch 36, 40 / Ant. 3 + Ant. 4
<b>Test Date</b>	May 26, 2011		

##### Channel 36

	Freq	Level	Limit	Over	Read	Cable	Antenna	Preamp	Remark	Pol/Phase
	MHz	dBuV/m	dBuV/m	dB	dBuV	Loss	Factor	Factor		
						dB	dB/m	dB		
1	5148.40	75.31	80.00	-4.69	36.86	4.44	34.01	0.00	Peak	VERTICAL
2	5150.00	59.97	60.00	-0.03	21.52	4.44	34.01	0.00	Average	VERTICAL
3	5174.80	117.07				4.43	34.04	0.00	Peak	VERTICAL
4	5176.40	105.99				4.43	34.04	0.00	Average	VERTICAL

Item 3, 4 are the fundamental frequency at 5180 MHz.

##### Channel 40

	Freq	Level	Limit	Over	Read	Cable	Preamp	Antenna	T/Pos	A/Pos	Remark	Pol/Phase
	MHz	dBuV/m	dBuV/m	dB	dBuV	Loss	Factor	Factor	deg	cm		
						dB	dB	dB/m				
1	5116.00	70.15	80.00	-9.85	34.07	3.07	0.00	33.01	281	100	Peak	HORIZONTAL
2	5116.40	58.03	60.00	-1.97	21.95	3.07	0.00	33.01	281	100	Average	HORIZONTAL
3	5196.40	117.53				3.11	0.00	33.16	281	100	Peak	HORIZONTAL
4	5204.00	107.54				3.11	0.00	33.16	281	100	Average	HORIZONTAL

Item 3, 4 are the fundamental frequency at 5200 MHz.

<b>Temperature</b>	24°C	<b>Humidity</b>	60%
<b>Test Engineer</b>	Benson Peng	<b>Configurations</b>	IEEE 802.11n (2TX/2RX) MCS0 40MHz Ch 38, 46 / Ant. 3 + Ant. 4
<b>Test Date</b>	May 26, 2011		

### Channel 38

	Freq	Level	Limit Line	Over Limit	Read Level	Cable Loss	Antenna Factor	Preamp Factor	Remark	Pol/Phase
	MHz	dBuV/m	dBuV/m	dB	dBuV	dB	dB/m	dB		
1	5149.20	76.01	80.00	-3.99	37.56	4.44	34.01	0.00	Peak	HORIZONTAL
2	5150.00	59.97	60.00	-0.03	21.52	4.44	34.01	0.00	Average	HORIZONTAL
3	5176.00	110.90				4.43	34.04	0.00	Peak	HORIZONTAL
4	5193.60	97.58				4.43	34.08	0.00	Average	HORIZONTAL

Item 3, 4 are the fundamental frequency at 5190 MHz.

### Channel 46

	Freq	Level	Limit Line	Over Limit	Read Level	Cable Loss	Preamp Factor	Antenna Factor	T/Pos	A/Pos	Remark	Pol/Phase
	MHz	dBuV/m	dBuV/m	dB	dBuV	dB	dB	dB/m	deg	cm		
1	5149.20	54.49	60.00	-5.51	18.33	3.09	0.00	33.07	274	100	Average	HORIZONTAL
2	5149.60	66.07	80.00	-13.93	29.91	3.09	0.00	33.07	274	100	Peak	HORIZONTAL
3	5234.80	102.60				3.12	0.00	33.22	274	100	Average	HORIZONTAL
4	5237.20	114.29				3.12	0.00	33.22	274	100	Peak	HORIZONTAL

Item 3, 4 are the fundamental frequency at 5230 MHz.

#### Note:

Emission level (dBuV/m) = 20 log Emission level (uV/m)

Corrected Reading: Antenna Factor + Cable Loss + Read Level - Preamp Factor = Level

The limits above 5GHz shall be extrapolated to the specified distance using an extrapolation factor of 20 dB/decade from 3m to 1.5m.

Distance extrapolation factor = 20 log (specific distance [3m] / test distance [1.5m]) (dB);

Limit line = specific limits (dBuV) + distance extrapolation factor [6 dB].



<IEEE 802.11n (1TX/1RX)>

<b>Temperature</b>	24°C	<b>Humidity</b>	60%
<b>Test Engineer</b>	Magic Lai	<b>Configurations</b>	IEEE 802.11n (2TX/2RX) MCS0 20MHz Ch 36, 40 / Ant. 3 + Ant. 4
<b>Test Date</b>	Oct. 01, 2011		

**Channel 36**

	Freq	Level	Limit Line	Over Limit	Read Level	Cable Loss	Antenna Factor	Preamp Factor	T/Pos	A/Pos	Remark	Pol/Phase
	MHz	dBuV/m	dBuV/m	dB	dBuV	dB	dB/m	dB	deg	cm		
1	5092.80	71.03	80.00	-8.97	34.03	3.42	33.58	0.00	255	119	Peak	HORIZONTAL
2	5096.40	59.57	60.00	-0.43	22.57	3.42	33.58	0.00	255	119	Average	HORIZONTAL
3	5184.40	105.34				3.44	33.73	0.00	255	119	Average	HORIZONTAL
4	5186.80	114.93				3.44	33.73	0.00	255	119	Peak	HORIZONTAL

Item 3, 4 are the fundamental frequency at 5180 MHz.

**Channel 40**

	Freq	Level	Limit Line	Over Limit	Read Level	Cable Loss	Antenna Factor	Preamp Factor	T/Pos	A/Pos	Remark	Pol/Phase
	MHz	dBuV/m	dBuV/m	dB	dBuV	dB	dB/m	dB	deg	cm		
1	5122.40	70.56	80.00	-9.44	33.52	3.43	33.61	0.00	253	122	Peak	HORIZONTAL
2	5124.40	58.81	60.00	-1.19	21.77	3.43	33.61	0.00	253	122	Average	HORIZONTAL
3	5195.20	105.93				3.45	33.76	0.00	253	122	Average	HORIZONTAL
4	5196.00	116.04				3.45	33.76	0.00	253	122	Peak	HORIZONTAL

Item 3, 4 are the fundamental frequency at 5200 MHz.



<b>Temperature</b>	24°C	<b>Humidity</b>	60%
<b>Test Engineer</b>	Magic Lai	<b>Configurations</b>	IEEE 802.11n (2TX/2RX) MCS0 40MHz Ch 38, 46 / Ant. 3 + Ant. 4
<b>Test Date</b>	Oct. 01, 2011		

**Channel 38**

	Freq	Level	Limit Line	Over Limit	Read Level	CableAntenna Loss	Preamp Factor	Remark	Pol/Phase
	MHz	dBuV/m	dBuV/m	dB	dBuV	dB	dB/m	dB	
1	5147.12	74.18	80.00	-5.82	35.73	4.44	34.01	0.00	Peak VERTICAL
2	5150.00	59.30	60.00	-0.70	20.85	4.44	34.01	0.00	Average VERTICAL
3	5185.83	96.83				4.43	34.08	0.00	Average VERTICAL
4	5185.83	108.16				4.43	34.08	0.00	Peak VERTICAL

Item 3, 4 are the fundamental frequency at 5190 MHz.

**Channel 46**

	Freq	Level	Limit Line	Over Limit	Read Level	CableAntenna Loss	Preamp Factor	T/Pos	A/Pos	Remark	Pol/Phase
	MHz	dBuV/m	dBuV/m	dB	dBuV	dB	dB/m	deg	cm		
1	5148.40	56.84	60.00	-3.16	19.74	3.43	33.67	0.00	237	122	Average HORIZONTAL
2	5149.20	69.33	80.00	-10.67	32.23	3.43	33.67	0.00	237	122	Peak HORIZONTAL
3	5224.00	103.07				3.46	33.79	0.00	237	122	Average HORIZONTAL
4	5224.00	113.24				3.46	33.79	0.00	237	122	Peak HORIZONTAL

Item 3, 4 are the fundamental frequency at 5230 MHz.

Note:

Emission level (dBuV/m) = 20 log Emission level (uV/m)

Corrected Reading: Antenna Factor + Cable Loss + Read Level - Preamp Factor = Level

The limits above 5GHz shall be extrapolated to the specified distance using an extrapolation factor of 20 dB/decade from 3m to 1.5m.

Distance extrapolation factor = 20 log (specific distance [3m] / test distance [1.5m]) (dB);

Limit line = specific limits (dBuV) + distance extrapolation factor [6 dB].



<IEEE 802.11a (1TX/1RX)>

Temperature	24°C	Humidity	60%
Test Engineer	Benson Peng	Configurations	IEEE 802.11a (1TX/1RX) Ch 36, 40 / Ant. 4
Test Date	May 13, 2011		

Channel 36

	Freq	Level	Limit Line	Over Limit	Read Level	Cable Loss	Antenna Factor	Preamp Factor	Remark	Pol/Phase
	MHz	dBuV/m	dBuV/m	dB	dBuV	dB	dB/m	dB		
1	5146.20	75.54	80.00	-4.46	37.09	4.44	34.01	0.00	Peak	HORIZONTAL
2	5150.00	59.94	60.00	-0.06	21.49	4.44	34.01	0.00	Average	HORIZONTAL
3	5176.40	106.27				4.43	34.04	0.00	Average	HORIZONTAL
4	5178.40	116.60				4.43	34.08	0.00	Peak	HORIZONTAL

Item 3, 4 are the fundamental frequency at 5180 MHz.

Channel 40

	Freq	Level	Limit Line	Over Limit	Read Level	Cable Loss	Preamp Factor	Antenna Factor	T/Pos	A/Pos	Remark	Pol/Phase
	MHz	dBuV/m	dBuV/m	dB	dBuV	dB	dB	dB/m	deg	cm		
1	5120.00	55.38	60.00	-4.62	19.29	3.08	0.00	33.01	280	115	Average	HORIZONTAL
2	5150.00	67.07	80.00	-12.93	30.91	3.09	0.00	33.07	280	115	Peak	HORIZONTAL
3	5204.00	106.03				3.11	0.00	33.16	280	115	Average	HORIZONTAL
4	5204.80	116.44				3.11	0.00	33.16	280	115	Peak	HORIZONTAL

Item 3, 4 are the fundamental frequency at 5200 MHz.

Note:

Emission level (dBuV/m) = 20 log Emission level (uV/m)

Corrected Reading: Antenna Factor + Cable Loss + Read Level - Preamp Factor = Level

The limits above 5GHz shall be extrapolated to the specified distance using an extrapolation factor of 20 dB/decade from 3m to 1.5m.

Distance extrapolation factor = 20 log (specific distance [3m] / test distance [1.5m]) (dB);

Limit line = specific limits (dBuV) + distance extrapolation factor [6 dB].

## &lt;IEEE 802.11a (1TX/1RX)&gt;

<b>Temperature</b>	24°C	<b>Humidity</b>	60%
<b>Test Engineer</b>	Magic Lai	<b>Configurations</b>	IEEE 802.11a (1TX/1RX) Ch 36, 40 / Ant. 3
<b>Test Date</b>	Oct. 01, 2011		

## Channel 36

	Freq	Level	Limit Line	Over Limit	Read Level	Cable Loss	Antenna Factor	Preamp Factor	T/Pos	A/Pos	Remark	Pol/Phase
	MHz	dBuV/m	dBuV/m	dB	dBuV	dB	dB/m	dB	deg	cm		
1	5096.40	59.47	60.00	-0.53	22.47	3.42	33.58	0.00	243	122	Average	HORIZONTAL
2	5097.20	71.37	80.00	-8.63	34.37	3.42	33.58	0.00	243	122	Peak	HORIZONTAL
3	5172.40	105.17				3.44	33.70	0.00	243	122	Average	HORIZONTAL
4	5172.80	114.68				3.44	33.70	0.00	243	122	Peak	HORIZONTAL

Item 3, 4 are the fundamental frequency at 5180 MHz.

## Channel 40

	Freq	Level	Limit Line	Over Limit	Read Level	Cable Loss	Antenna Factor	Preamp Factor	T/Pos	A/Pos	Remark	Pol/Phase
	MHz	dBuV/m	dBuV/m	dB	dBuV	dB	dB/m	dB	deg	cm		
1	5122.40	70.06	80.00	-9.94	33.02	3.43	33.61	0.00	230	122	Peak	HORIZONTAL
2	5125.20	58.94	60.00	-1.06	21.90	3.43	33.61	0.00	230	122	Average	HORIZONTAL
3	5196.00	106.08				3.45	33.76	0.00	230	122	Average	HORIZONTAL
4	5196.40	116.23				3.45	33.76	0.00	230	122	Peak	HORIZONTAL

Item 3, 4 are the fundamental frequency at 5200 MHz.

## Note:

Emission level (dBuV/m) = 20 log Emission level (uV/m)

Corrected Reading: Antenna Factor + Cable Loss + Read Level - Preamp Factor = Level

The limits above 5GHz shall be extrapolated to the specified distance using an extrapolation factor of 20 dB/decade from 3m to 1.5m.

Distance extrapolation factor = 20 log (specific distance [3m] / test distance [1.5m]) (dB);

Limit line = specific limits (dBuV) + distance extrapolation factor [6 dB].



## 4.8. Frequency Stability Measurement

### 4.8.1. Limit

Manufacturers of U-NII devices are responsible for ensuring frequency stability such that an emissions is maintained within the band of operation under all conditions of normal operation as specified in the user's manual or  $\pm 20\text{ppm}$  (IEEE 802.11 specification).

### 4.8.2. Measuring Instruments and Setting

Please refer to section 5 of equipments list in this report. The following table is the setting of the spectrum analyzer.

Spectrum Parameter	Setting
Attenuation	Auto
Span Frequency	Entire absence of modulation emissions bandwidth
RB	10 kHz
VB	10 kHz
Sweep Time	Auto

### 4.8.3. Test Procedures

1. The transmitter output (antenna port) was connected to the spectrum analyzer.
2. EUT have transmitted absence of modulation signal and fixed channelize.
3. Set the spectrum analyzer span to view the entire absence of modulation emissions bandwidth.
4. Set RBW = 10 kHz, VBW = 10 kHz with peak detector and maxhold settings.
5.  $f_c$  is declaring of channel frequency. Then the frequency error formula is  $(f_c - f) / f_c \times 10^6$  ppm and the limit is less than  $\pm 20\text{ppm}$  (IEEE 802.11 specification).
6. The test extreme voltage is to change the primary supply voltage from 85 to 115 percent of the nominal value
7. Extreme temperature rule is  $-30^\circ\text{C} \sim 50^\circ\text{C}$ .

### 4.8.4. Test Setup Layout

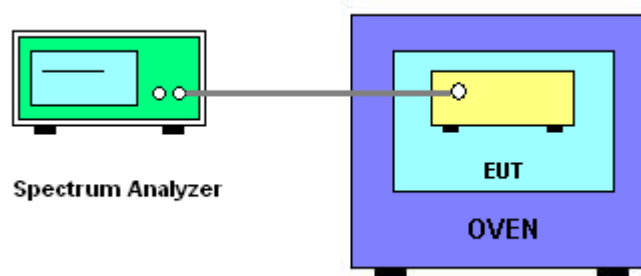

#### 4.8.5. Test Deviation

There is no deviation with the original standard.

#### 4.8.6. EUT Operation during Test

The EUT was programmed to be in continuously un-modulation transmitting mode.

#### 4.8.7. Test Result of Frequency Stability

##### Voltage vs. Frequency Stability

Voltage	Measurement Frequency (MHz)
(V)	5200
126.50	5200.018987
110.00	5200.028826
93.50	5200.026845
Max. Deviation (MHz)	0.028826
Max. Deviation (ppm)	5.54

##### Temperature vs. Frequency Stability

Temperature	Measurement Frequency (MHz)
(°C)	5200
-30	5200.0700
-20	5200.0700
-10	5200.0700
0	5200.0600
10	5200.0600
20	5200.0400
30	5200.0400
40	5200.0400
50	5200.0500
Max. Deviation (MHz)	0.070000
Max. Deviation (ppm)	13.46

## 4.9. Antenna Requirements

### 4.9.1. Limit

Except for special regulations, the Low-power Radio-frequency Devices must not be equipped with any jacket for installing an antenna with extension cable. An intentional radiator shall be designed to ensure that no antenna other than that furnished by the responsible party shall be used with the device. The use of a permanently attached antenna or of an antenna that uses a unique coupling to the intentional radiator shall be considered sufficient to comply with the provisions of this Section. The manufacturer may design the unit so that the user can replace a broken antenna, but the use of a standard antenna jack or electrical connector is prohibited. Further, this requirement does not apply to intentional radiators that must be professionally installed.

### 4.9.2. Antenna Connector Construction

Please refer to section 3.3 in this test report; antenna connector complied with the requirements.

## 5. LIST OF MEASURING EQUIPMENTS

Instrument	Manufacturer	Model No.	Serial No.	Characteristics	Calibration Date	Remark
EMI Test Receiver	R&S	ESCS 30	100377	9kHz ~ 2.75GHz	Sep. 01, 2010	Conduction (CO01-CB)
LISN	F.C.C.	FCC-LISN-50-16-2	04083	150kHz ~ 100MHz	Apr. 24, 2011	Conduction (CO01-CB)
V- LISN	Schwarzbeck	NSLK 8127	8127-478	9K ~ 30MHz	Oct. 30, 2010	Conduction (CO01-CB)
PULSE LIMITER	R&S	ESH3-Z2	100430	9K~30MHz	Jan. 04, 2011	Conduction (CO01-CB)
COND Cable	-	Cable	-	0.15MHz~30MHz	Dec. 01, 2010	Conduction (CO01-CB)
BILOG ANTENNA	Schaffner	CBL6112D	22021	20MHz ~ 2GHz	Oct. 17, 2010	Radiation (03CH01-CB)
Horn Antenna	EMCO	3115	00075790	750MHz~18GHz	Nov. 13, 2010	Radiation (03CH01-CB)
Horn Antenna	SCHWARZBEAK	BBHA 9170	BBHA9170252	15GHz ~ 40GHz	Oct. 08, 2010	Radiation (03CH01-CB)
Pre-Amplifier	Agilent	8447D	2944A10991	0.1MHz ~ 1.3GHz	Nov. 17, 2010	Radiation (03CH01-CB)
Pre-Amplifier	Agilent	8449B	3008A02310	1GHz ~ 26.5GHz	Nov. 06, 2010	Radiation (03CH01-CB)
Pre-Amplifier	WM	TF-130N-R1	923365	26.5GHz ~ 40GHz	Nov. 17, 2010	Radiation (03CH01-CB)
Spectrum analyzer	R&S	FSP	100304	9kHz ~ 40GHz	Nov. 06, 2010	Radiation (03CH01-CB)
EMI Test Receiver	R&S	ESCS 30	100355	9KHz ~ 2.75GHz	Mar. 06, 2011	Radiation (03CH01-CB)
Loop Antenna	R&S	HFH2-Z2	860004/001	9 kHz - 30 MHz	Sep. 09, 2010	Radiation (03CH01-CB)
Turn Table	INN CO	CO 2000	N/A	0 ~ 360 degree	N/A	Radiation (03CH01-CB)
Antenna Mast	INN CO	CO2000	N/A	1 m - 4 m	N/A	Radiation (03CH01-CB)
RF Cable-low	Woken	Low Cable-1	-	30 MHz - 1 GHz	Nov. 17, 2010	Radiation (03CH01-CB)
RF Cable-high	Woken	High Cable-1	-	1 GHz – 26.5 GHz	Nov. 17, 2010	Radiation (03CH01-CB)
RF Cable-high	Woken	High Cable-2	-	1 GHz – 26.5 GHz	Nov. 17, 2010	Radiation (03CH01-CB)
RF Cable-high	Woken	High Cable-3	-	1 GHz - 40 GHz	Nov. 17, 2010	Radiation (03CH01-CB)
RF Cable-high	Woken	High Cable-4	-	1 GHz - 40 GHz	Nov. 17, 2010	Radiation (03CH01-CB)
Spectrum analyzer	R&S	FSP30	100023	9KHz~30GHz	Mar. 05, 2011	Conducted (TH01-CB)
Temp. and Humidity Chamber	TEN BILLION	TTH-D3SP	TBN-931011	-30~100°C	May 21, 2010	Conducted (TH01-CB)
Temp. and Humidity Chamber	TEN BILLION	TTH-D3SP	TBN-931011	-30~100°C	May 21, 2011	Conducted (TH01-CB)
Signal Generator	R&S	SMR40	100302	10MHz-40GHz	Mar. 09, 2011	Conducted (TH01-CB)
RF Power Divider	HP	11636A	00306	2GHz ~ 18GHz	N/A	Conducted (TH01-CB)



Instrument	Manufacturer	Model No.	Serial No.	Characteristics	Calibration Date	Remark
RF Power Splitter	Anaren	44100	1839	2GHz ~ 18GHz	N/A	Conducted (TH01-CB)
RF Power Splitter	Anaren	42100	17930	2GHz ~ 18GHz	N/A	Conducted (TH01-CB)
RF Cable-high	Woken	High Cable-7	-	1 GHz – 26.5 GHz	Nov. 17, 2010	Conducted (TH01-CB)
RF Cable-high	Woken	High Cable-8	-	1 GHz – 26.5 GHz	Nov. 17, 2010	Conducted (TH01-CB)
RF Cable-high	Woken	High Cable-9	-	1 GHz – 26.5 GHz	Nov. 17, 2010	Conducted (TH01-CB)
RF Cable-high	Woken	High Cable-10	-	1 GHz – 26.5 GHz	Nov. 17, 2010	Conducted (TH01-CB)
RF Cable-high	Woken	High Cable-11	-	1 GHz – 26.5 GHz	Nov. 17, 2010	Conducted (TH01-CB)
RF Cable-high	Woken	High Cable-12	-	1 GHz – 26.5 GHz	Nov. 17, 2010	Conducted (TH01-CB)
RF Cable-high	Woken	High Cable-13	-	1 GHz – 26.5 GHz	Nov. 17, 2010	Conducted (TH01-CB)
Power Sensor	Anritsu	MA2411B	0917223	300MHz~40GHz	Sep. 13, 2010	Conducted (TH01-CB)
Power Sensor	Anritsu	MA2411B	0917223	300MHz~40GHz	Sep. 13, 2011	Conducted (TH01-CB)
Power Meter	Anritsu	ML2495A	1035008	300MHz~40GHz	Sep. 08, 2010	Conducted (TH01-CB)
Power Meter	Anritsu	ML2495A	1035008	300MHz~40GHz	Sep. 08, 2011	Conducted (TH01-CB)

Note: Calibration Interval of instruments listed above is one year.

\* Calibration Interval of instruments listed above is two years.

NCR means Non-Calibration required.

## 6. TEST LOCATION

SHIJR	ADD : 6Fl., No. 106, Sec. 1, Shintai 5th Rd., Shijr City, Taipei, Taiwan 221, R.O.C. TEL : 886-2-2696-2468 FAX : 886-2-2696-2255
HWA YA	ADD : No. 52, Hwa Ya 1st Rd., Kwei-Shan Hsiang, Tao Yuan Hsien, Taiwan, R.O.C. TEL : 886-3-327-3456 FAX : 886-3-318-0055
LINKOU	ADD : No. 30-2, Dingfu Tsuen, Linkou Shiang, Taipei, Taiwan 244, R.O.C TEL : 886-2-2601-1640 FAX : 886-2-2601-1695
DUNGHU	ADD : No. 3, Lane 238, Kangle St., Neihu Chiu, Taipei, Taiwan 114, R.O.C. TEL : 886-2-2631-4739 FAX : 886-2-2631-9740
JUNGHE	ADD : 7Fl., No. 758, Jungjeng Rd., Junghe City, Taipei, Taiwan 235, R.O.C. TEL : 886-2-8227-2020 FAX : 886-2-8227-2626
NEIHU	ADD : 4Fl., No. 339, Hsin Hu 2 <sup>nd</sup> Rd., Taipei 114, Taiwan, R.O.C. TEL : 886-2-2794-8886 FAX : 886-2-2794-9777
JHUBEI	ADD : No.8, Lane 724, Bo-ai St., Jhubei City, HsinChu County 302, Taiwan, R.O.C. TEL : 886-3-656-9065 FAX : 886-3-656-9085

## 7. TAF CERTIFICATE OF ACCREDITATION



Certificate No. : L1190-110702

財團法人全國認證基金會  
Taiwan Accreditation Foundation

### Certificate of Accreditation

This is to certify that

**Sporton International Inc.**  
**EMC & Wireless Communications Laboratory**  
No.52, Hwa Ya 1st Road, Hwa Ya Technology Park, Kwei-Shan Hsiang, Tao Yuan Hsien,  
Taiwan, R.O.C.

**is accredited in respect of laboratory**

<b>Accreditation Criteria</b>	: ISO/IEC 17025:2005
<b>Accreditation Number</b>	: 1190
<b>Originally Accredited</b>	: December 15, 2003
<b>Effective Period</b>	: January 10, 2010 to January 09, 2013
<b>Accredited Scope</b>	: Testing Field, see described in the Appendix
<b>Specific Accreditation Program</b>	: Accreditation Program for Designated Testing Laboratory for Commodities Inspection Accreditation Program for Telecommunication Equipment Testing Laboratory Accreditation Program for BSMI Mutual Recognition Arrangement with Foreign Authorities

  
Jay-San Chen  
President, Taiwan Accreditation Foundation  
Date : July 02, 2011

P1, total 22 pages

The Appendix forms an integral part of this Certificate, which shall be invalid when use without the Appendix