



SPORTON International Inc.

No. 52, Hwa Ya 1st Rd., Kwei-Shan Hsiang, TaoYuan Hsien, Taiwan, R.O.C.
Ph: 886-3-327-3456 / FAX: 886-3-327-0973 / www.sporton.com.tw

FCC RADIO TEST REPORT

Applicant's company	NETGEAR, Inc.
Applicant Address	350 East Plumeria Drive, San Jose, California 95134-1911
FCC ID	PY310100129
Manufacturer's company	Ambit Microsystems (Shanghai) Ltd.
Manufacturer Address	No. 1925, Nanle Road, Songjiang Export Processing Zone, Shanghai, China

Product Name	N600 Wireless Dual Band Gigabit VDSL2 Modem Router
Brand Name	NETGEAR
Model Name	DGND3700
Test Rule Part(s)	47 CFR FCC Part 15 Subpart E § 15.407
Test Freq. Range	5150 ~ 5250MHz
Received Date	Nov. 18, 2010
Final Test Date	Feb. 18, 2011
Submission Type	Original Equipment
Operating Mode	Master

Statement

Test result included is for the IEEE 802.11n and IEEE 802.11a of the product.

The test result in this report refers exclusively to the presented test model / sample.

Without written approval of SPORTON International Inc., the test report shall not be reproduced except in full.

The measurements and test results shown in this test report were made in accordance with the procedures and found in compliance with the limit given in **ANSI C63.4-2003** and **47 CFR FCC Part 15 Subpart E**.

The test equipment used to perform the test is calibrated and traceable to NML/ROC.



Testing Laboratory
1190

Table of Contents

1. CERTIFICATE OF COMPLIANCE	1
2. SUMMARY OF THE TEST RESULT	2
3. GENERAL INFORMATION	3
3.1. Product Details.....	3
3.2. Accessories.....	5
3.3. Table for Filed Antenna.....	5
3.4. Table for Carrier Frequencies	6
3.5. Table for Test Modes.....	6
3.6. Table for Testing Locations.....	7
3.7. Table for Supporting Units	8
3.8. Table for Parameters of Test Software Setting	8
3.9. Test Configurations	9
4. TEST RESULT	12
4.1. AC Power Line Conducted Emissions Measurement.....	12
4.2. 99% Occupied Bandwidth Measurement	16
4.3. Maximum Conducted Output Power Measurement.....	23
4.4. Power Spectral Density Measurement	27
4.5. Peak Excursion Measurement.....	32
4.6. Radiated Emissions Measurement	37
4.7. Band Edge Emissions Measurement	51
4.8. Frequency Stability Measurement	55
4.9. Antenna Requirements	57
5. LIST OF MEASURING EQUIPMENTS	58
6. TEST LOCATION.....	60
7. TAF CERTIFICATE OF ACCREDITATION	61
APPENDIX A. PHOTOGRAPHS OF EUT.....	A1 ~ A12
APPENDIX B. TEST PHOTOS.....	B1 ~ B5
APPENDIX C. MAXIMUM PERMISSIBLE EXPOSURE.....	C1 ~ C3
APPENDIX D. CO-LOCATION TEST REPORT	D1 ~ D6



History of This Test Report

REPORT NO.	VERSION	DESCRIPTION	ISSUED DATE
FR0D0633AA	Rev. 01	Initial issue of report	Mar. 01, 2011



1. CERTIFICATE OF COMPLIANCE

Product Name : N600 Wireless Dual Band Gigabit VDSL2 Modem Router
Brand Name : NETGEAR
Model Name : DGND3700
Applicant : NETGEAR, Inc.
Test Rule Part(s) : 47 CFR FCC Part 15 Subpart E § 15.407

Sporton International as requested by the applicant to evaluate the EMC performance of the product sample received on Nov. 18, 2010 would like to declare that the tested sample has been evaluated and found to be in compliance with the tested rule parts. The data recorded as well as the test configuration specified is true and accurate for showing the sample's EMC nature.

Jordan Hsiao 2011.3.10

Jordan Hsiao

SPORTON INTERNATIONAL INC.

2. SUMMARY OF THE TEST RESULT

Applied Standard: 47 CFR FCC Part 15 Subpart E				
Part	Rule Section	Description of Test	Result	Under Limit
4.1	15.207	AC Power Line Conducted Emissions	Complies	6.28 dB
4.2	15.407(a)	26dB Spectrum Bandwidth	Complies	-
4.3	15.407(a)	Maximum Conducted Output Power	Complies	0.04 dB
4.4	15.407(a)	Power Spectral Density	Complies	0.66 dB
4.5	15.407(a)	Peak Excursion	Complies	6.74 dB
4.6	15.407(b)	Radiated Emissions	Complies	0.77 dB
4.7	15.407(b)	Band Edge Emissions	Complies	0.34 dB
4.8	15.407(g)	Frequency Stability	Complies	-
4.9	15.203	Antenna Requirements	Complies	-

Test Items	Uncertainty	Remark
AC Power Line Conducted Emissions	±2.3dB	Confidence levels of 95%
Maximum Conducted Output Power	±0.5dB	Confidence levels of 95%
Power Spectral Density	±0.5dB	Confidence levels of 95%
Peak Excursion	±0.5dB	Confidence levels of 95%
26dB Spectrum Bandwidth / Frequency Stability	±8.5×10 ⁻⁸	Confidence levels of 95%
Radiated Emissions (9kHz~30MHz)	±0.8dB	Confidence levels of 95%
Radiated Emissions (30MHz~1000MHz)	±1.9dB	Confidence levels of 95%
Radiated / Band Edge Emissions (1GHz~18GHz)	±1.9dB	Confidence levels of 95%
Radiated Emissions (18GHz~40GHz)	±1.9dB	Confidence levels of 95%
Temperature	±0.7°C	Confidence levels of 95%
Humidity	±3.2%	Confidence levels of 95%
DC / AC Power Source	±1.4%	Confidence levels of 95%

3. GENERAL INFORMATION

3.1. Product Details

IEEE 802.11n

Items	Description
Product Type	WLAN (2TX, 2RX)
Radio Type	Intentional Transceiver
Power Type	From Power Adapter
Modulation	see the below table for IEEE 802.11n
Data Modulation	OFDM (BPSK / QPSK / 16QAM / 64QAM)
Data Rate (Mbps)	see the below table for IEEE 802.11n
Frequency Range	5150 ~ 5250MHz
Channel Number	4 for 20MHz bandwidth ; 2 for 40MHz bandwidth
Channel Band Width (99%)	MCS0 (20MHz): 17.28 MHz ; MCS0 (40MHz): 36.64 MHz
Conducted Output Power	MCS0 (20MHz): 16.78 dBm ; MCS0 (40MHz): 16.60 dBm
Carrier Frequencies	Please refer to section 3.4
Antenna	Please refer to section 3.3

IEEE 802.11a

Items	Description
Product Type	WLAN (2TX, 2RX)
Radio Type	Intentional Transceiver
Power Type	From Power Adapter
Modulation	OFDM for IEEE 802.11a
Data Modulation	OFDM (BPSK / QPSK / 16QAM / 64QAM)
Data Rate (Mbps)	OFDM (6/9/12/18/24/36/48/54)
Frequency Range	5150 ~ 5250MHz
Channel Number	4
Channel Band Width (99%)	16.16 MHz
Conducted Output Power	16.96 dBm
Carrier Frequencies	Please refer to section 3.4
Antenna	Please refer to section 3.3

Antenna & Band width

Antenna	Single (TX)		Two (TX)	
	20 MHz	40 MHz	20 MHz	40 MHz
IEEE 802.11a	X	X	V	X
IEEE 802.11n	X	X	V	V

IEEE 802.11n spec

MCS Index	Nss	Modulation	R	NBPS	NCBPS		NDBPS		Datarate(Mbps)			
					20MHz	40MHz	20MHz	40MHz	800nsGI		400nsGI	
									20MHz	40MHz	20MHz	40MHz
0	1	BPSK	1/2	1	52	108	26	54	6.5	13.5	7.200	15
1	1	QPSK	1/2	2	104	216	52	108	13.0	27.0	14.400	30
2	1	QPSK	3/4	2	104	216	78	162	19.5	40.5	21.700	45
3	1	16-QAM	1/2	4	208	432	104	216	26.0	54.0	28.900	60
4	1	16-QAM	3/4	4	208	432	156	324	39.0	81.0	43.300	90
5	1	64-QAM	2/3	6	312	648	208	432	52.0	108.0	57.800	120
6	1	64-QAM	3/4	6	312	648	234	486	58.5	121.5	65.000	135
7	1	64-QAM	5/6	6	312	648	260	540	65.0	135.0	72.200	150
8	2	BPSK	1/2	1	104	216	52	108	13.0	27.0	14.444	30
9	2	QPSK	1/2	2	208	432	104	216	26.0	54.0	28.889	60
10	2	QPSK	3/4	2	208	432	156	324	39.0	81.0	43.333	90
11	2	16-QAM	1/2	4	416	864	208	432	52.0	108.0	57.778	120
12	2	16-QAM	3/4	4	416	864	312	648	78.0	162.0	86.667	180
13	2	64-QAM	2/3	6	624	1296	416	864	104.0	216.0	115.556	240
14	2	64-QAM	3/4	6	624	1296	468	972	117.0	243.0	130.000	270
15	2	64-QAM	5/6	6	624	1296	520	1080	130.0	270.0	144.444	300

Symbol	Explanation
NSS	Number of spatial streams
R	Code rate
NBPS	Number of coded bits per single carrier
NCBPS	Number of coded bits per symbol
NDBPS	Number of data bits per symbol
GI	guard interval

3.2. Accessories

Power	Brand	Model	P/N	Rating
Adapter 1	NETGEAR	P030WF120B 11200-2LF	332-10200-01	Input: 100-240VAC, 50/60Hz, 1.0A Output: 12VDC, 2.5A
Adapter 2	NETGEAR	MU30-5120250-A1	332-10234-01	Input: 100-240VAC, 50/60Hz, 0.8A Output: 12VDC, 2.5A
Others				
RJ-11 Cable, Non-shielded, 1.5m				
RJ-45 Cable, Shielded, 1.5m				

3.3. Table for Filed Antenna

Ant.	Brand	Model Name	Antenna Type	Connector	Gain (dBi)	Remark
1	WNC	81.EZY15.G09	Dipole Antenna	I-PEX	3.4	5GHz Band
2	WNC	81.EZY15.G09	Dipole Antenna	I-PEX	3.4	5GHz Band

Note: The EUT has 4 antennas. (2 for 5GHz Band use, 2 for 2.4GHz Band use.)

Both Ant. 1 and Ant. 2 can be used as transmitting/receiving antenna.

Ant. 1 and Ant. 2 could transmit/receive simultaneously.

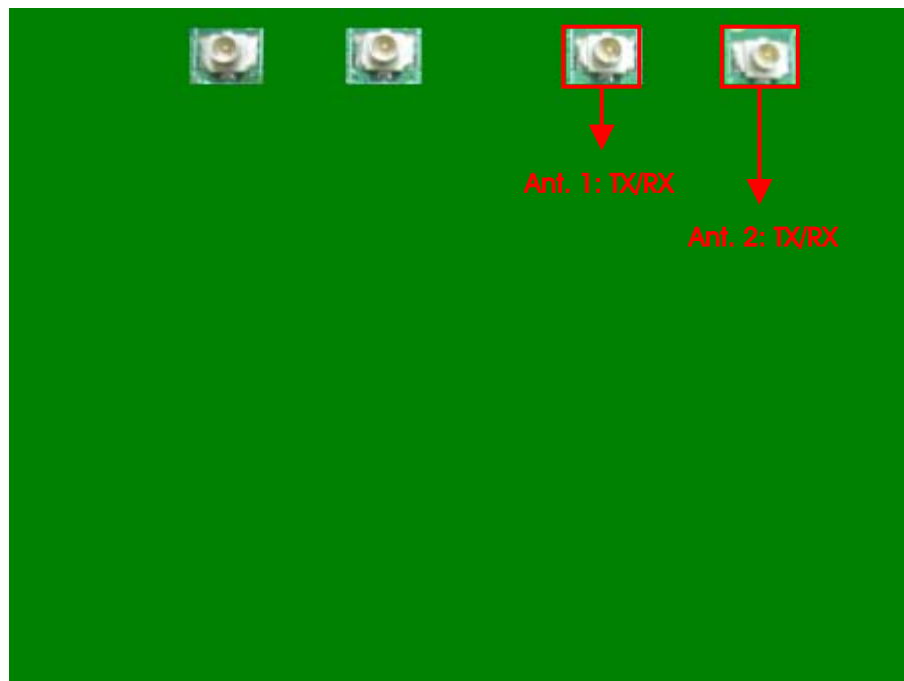

3.4. Table for Carrier Frequencies

For IEEE 802.11a, use Channel 36, 40, 44, 48.

There are two bandwidth systems for IEEE 802.11n.

For both 20MHz bandwidth systems, use Channel 36, 40, 44, 48.

For both 40MHz bandwidth systems, use Channel 38, 46.

Frequency Band	Channel No.	Frequency	Channel No.	Frequency
5150~5250 MHz Band 1	36	5180 MHz	44	5220 MHz
	38	5190 MHz	46	5230 MHz
	40	5200 MHz	48	5240 MHz

3.5. Table for Test Modes

Preliminary tests were performed in different data rate to find the worst radiated emission. The data rate shown in the table below is the worst-case rate with respect to the specific test item. Investigation has been done on all the possible configurations for searching the worst cases. The following table is a list of the test modes shown in this test report.

Test Items	Mode		Data Rate	Channel	Antenna
AC Power Conducted Emission	Normal Link		Auto	-	-
Max. Conducted Output Power	MCS0/20MHz	Band 1	6.5Mbps	36/40/48	1/2/1+2
	MCS0/40MHz	Band 1	13.5Mbps	38/46	1/2/1+2
	11a/BPSK	Band 1	6Mbps	36/40/48	1/2/1+2
26dB Spectrum Bandwidth 99% Occupied Bandwidth	MCS0/20MHz	Band 1	6.5Mbps	36/40/48	1+2
	MCS0/40MHz	Band 1	13.5Mbps	38/46	1+2
Power Spectral Density Peak Excursion	11a/BPSK	Band 1	6Mbps	36/40/48	1+2
Radiated Emission Below 1GHz	Normal Link		Auto	-	-
Radiated Emission Above 1GHz	MCS0/20MHz	Band 1	6.5Mbps	36/40/48	1+2
	MCS0/40MHz	Band 1	13.5Mbps	38/46	1+2
	11a/BPSK	Band 1	6Mbps	36/40/48	1+2
Band Edge Emission	MCS0/20MHz	Band 1	6.5Mbps	36/40	1+2
	MCS0/40MHz	Band 1	13.5Mbps	38/46	1+2
	11a/BPSK	Band 1	6Mbps	36/40	1+2
Frequency Stability	Un-modulation		-	40	N/A

All the test modes were listed as below.

For Conducted Emissions Test:

Mode 1: EUT (Wireless + LAN + WAN + USB Read/Write) + Adapter 1

Mode 2: EUT (Wireless + LAN + WAN + USB Read/Write) + Adapter 2

Mode 2 has been evaluated to be the worst case, thus measurement will follow this same test mode.

Mode 3: EUT (Wireless + LAN + ADSL Annex A + USB Read/Write) + Adapter 2

Mode 4: EUT (Wireless + LAN + ADSL Annex M + USB Read/Write) + Adapter 2

Due to Mode 2 generated the worst test result, so it was recorded in this report.

For Radiated Emissions Test:

Mode 1: EUT (Wireless + LAN + WAN + USB Read/Write) + Adapter 1

Mode 2: EUT (Wireless + LAN + ADSL Annex A + USB Read/Write) + Adapter 1

Mode 3: EUT (Wireless + LAN + ADSL Annex M + USB Read/Write) + Adapter 1

Mode 3 has been evaluated to be the worst case, thus measurement will follow this same test mode.

Mode 4: EUT (Wireless + LAN + ADSL Annex M + USB Read/Write) + Adapter 2

Due to Mode 3 generated the worst test result, so it was recorded in this report.

For MPE and Co-location Test:

The EUT could be applied with wireless LAN function 2.4GHz Band and wireless LAN function 5GHz Band; therefore Maximum Permissible Exposure (please refer to Appendix C) and Co-location (please refer to Appendix D) tests are added for simultaneously transmit between wireless LAN function 2.4GHz Band and wireless LAN function 5GHz Band.

3.6. Table for Testing Locations

Test Site No.	Site Category	Location	FCC Reg. No.	IC File No.	VCCI Reg. No
03CH01-CB	SAC	Hsin Chu	187376	IC 4086D	-
CO01-CB	Conduction	Hsin Chu	187376	IC 4086D	-
TH01-CB	OVEN Room	Hsin Chu	-	-	-

Open Area Test Site (OATS); Semi Anechoic Chamber (SAC); Fully Anechoic Chamber (FAC).

Please refer section 6 for Test Site Address.

3.7. Table for Supporting Units

Support Unit	Brand	Model	FCC ID
Notebook	DELL	M1330	E2K4965AGNM
Mouse	iCooky	AMS0706W	DoC
Modem	ACEEX	DM1414	IFAXDM1414
USB 2.0 Flash Drive Dongle	SILICON POWER	SP002GBUF2M01V1K	DoC
Notebook	DELL	D400	QDS-BRCM1005-D
Notebook	DELL	D400	QDS-BRCM1005-D
ADSL 2+ Simulator	ZYXEL	IES-1000	DoC

3.8. Table for Parameters of Test Software Setting

During testing, Channel & Power Controlling Software provided by the customer was used to control the operating channel as well as the output power level. The RF output power selection is for the setting of RF output power expected by the customer and is going to be fixed on the firmware of the final end product.

Power Parameters of IEEE 802.11n MCS0 20MHz

Test Software Version	DOS		
Frequency	5180 MHz	5200 MHz	5240 MHz
MCS0 20MHz	52	52	56

Power Parameters of IEEE 802.11n MCS0 40MHz

Test Software Version	DOS	
Frequency	5190 MHz	5230 MHz
MCS0 40MHz	48	58

Power Parameters of IEEE 802.11a

Test Software Version	DOS		
Frequency	5180 MHz	5200 MHz	5240 MHz
IEEE 802.11a	54	54	54

During the test, "DOS" under WIN XP was executed to control the EUT continuously transmit RF signal.

3.9. Test Configurations

3.9.1. Radiation Emissions Test Configuration

Test Configuration: 9KHz~1GHz

Test Mode: Mode 3

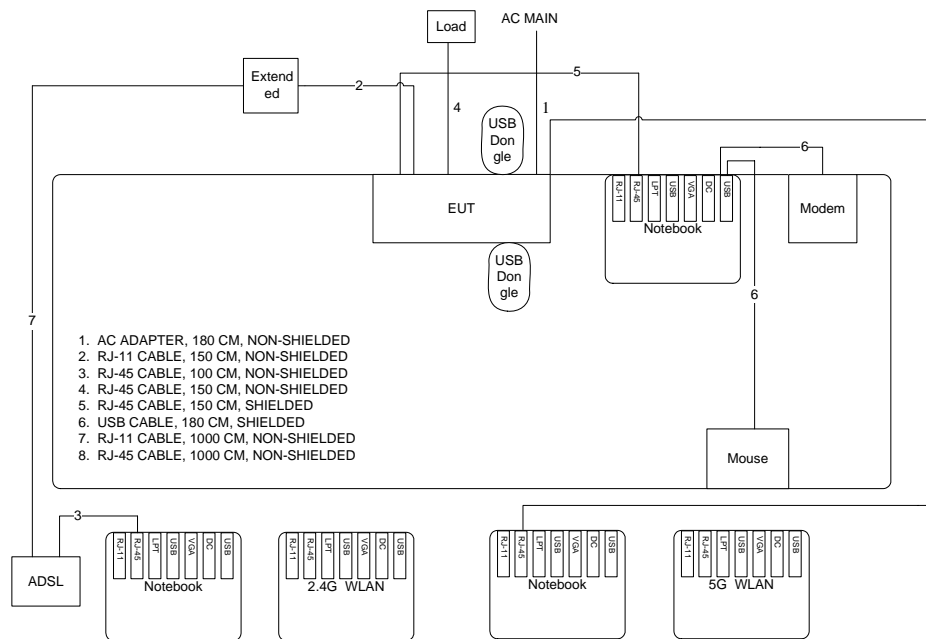

Test Configuration: above 1GHz

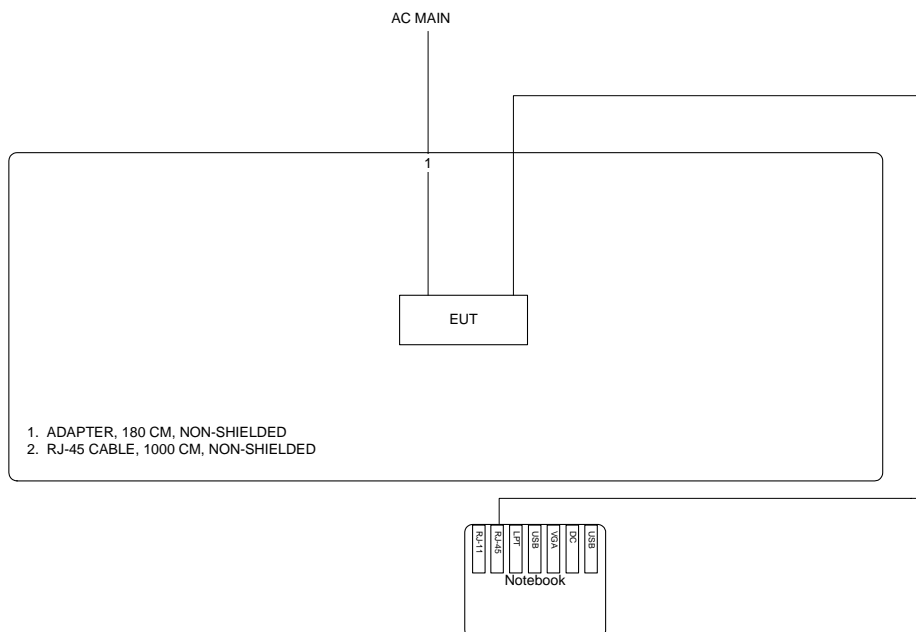

Test Configuration: Co-Location

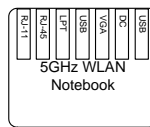
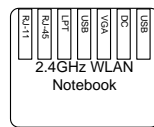
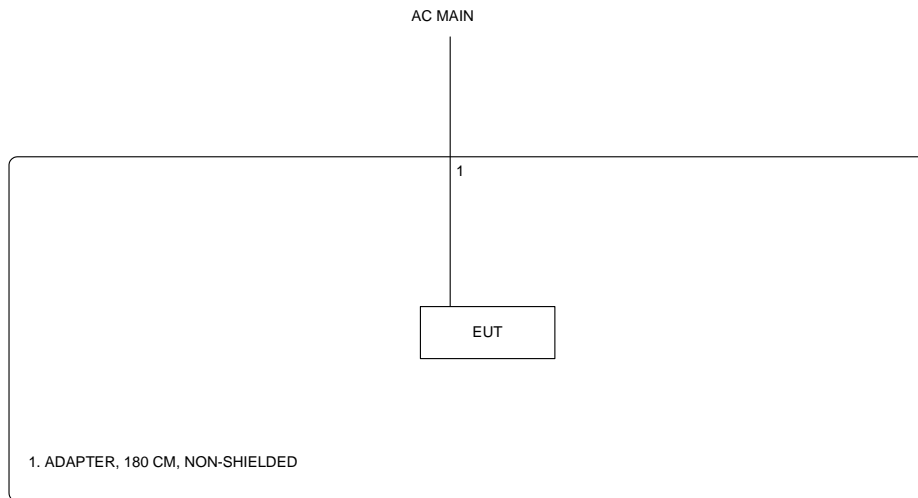

3.9.2. AC Power Line Conduction Emissions Test Configuration

Test Mode: Mode 2

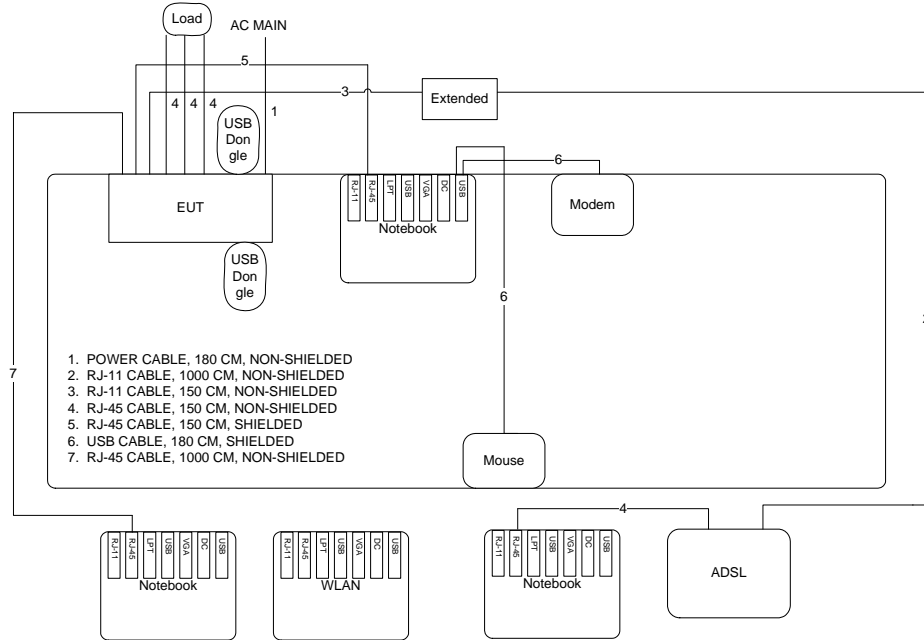

4. TEST RESULT

4.1. AC Power Line Conducted Emissions Measurement

4.1.1. Limit

For this product that is designed to connect to the AC power line, the radio frequency voltage that is conducted back onto the AC power line on any frequency or frequencies within the band 150 kHz to 30 MHz shall not exceed below limits table.

Frequency (MHz)	QP Limit (dBuV)	AV Limit (dBuV)
0.15~0.5	66~56	56~46
0.5~5	56	46
5~30	60	50

4.1.2. Measuring Instruments and Setting

Please refer to section 5 of equipments list in this report. The following table is the setting of the receiver.

Receiver Parameters	Setting
Attenuation	10 dB
Start Frequency	0.15 MHz
Stop Frequency	30 MHz
IF Bandwidth	9 KHz

4.1.3. Test Procedures

1. Configure the EUT according to ANSI C63.4. The EUT or host of EUT has to be placed 0.4 meter far from the conducting wall of the shielding room and at least 80 centimeters from any other grounded conducting surface.
2. Connect EUT or host of EUT to the power mains through a line impedance stabilization network (LISN).
3. All the support units are connected to the other LISNs. The LISN should provide 50uH/50ohms coupling impedance.
4. The frequency range from 150 KHz to 30 MHz was searched.
5. Set the test-receiver system to Peak Detect Function and Specified Bandwidth with Maximum Hold Mode.
6. The measurement has to be done between each power line and ground at the power terminal.

4.1.4. Test Setup Layout

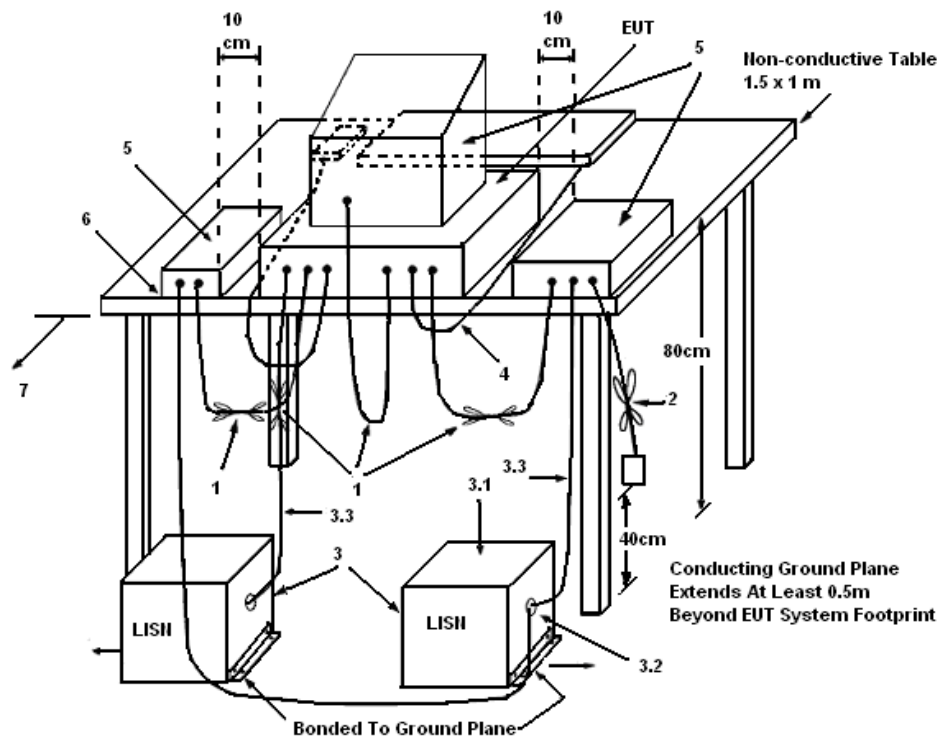

LEGEND:

- (1) Interconnecting cables that hang closer than 40 cm to the ground plane shall be folded back and forth in the center forming a bundle 30 to 40 cm long.
- (2) I/O cables that are not connected to a peripheral shall be bundled in the center. The end of the cable may be terminated, if required, using the correct terminating impedance. The overall length shall not exceed 1 m.
- (3) EUT connected to one LISN. Unused LISN measuring port connectors shall be terminated in 50 Ω . LISN can be placed on top of, or immediately beneath, reference ground plane.
 - (3.1) All other equipment powered from additional LISN(s).
 - (3.2) Multiple outlet strip can be used for multiple power cords of non-EUT equipment.
 - (3.3) LISN at least 80 cm from nearest part of EUT chassis.
- (4) Cables of hand-operated devices, such as keyboards, mice, etc., shall be placed as for normal use.
- (5) Non-EUT components of EUT system being tested.
- (6) Rear of EUT, including peripherals, shall all be aligned and flush with rear of tabletop.
- (7) Rear of tabletop shall be 40 cm removed from a vertical conducting plane that is bonded to the ground plane.

4.1.5. Test Deviation

There is no deviation with the original standard.

4.1.6. EUT Operation during Test

The EUT was placed on the test table and programmed in normal function.

4.1.7. Results of AC Power Line Conducted Emissions Measurement

Temperature	23°C	Humidity	54%
Test Engineer	Peter Wu	Phase	Line
Configuration	Mode 2		

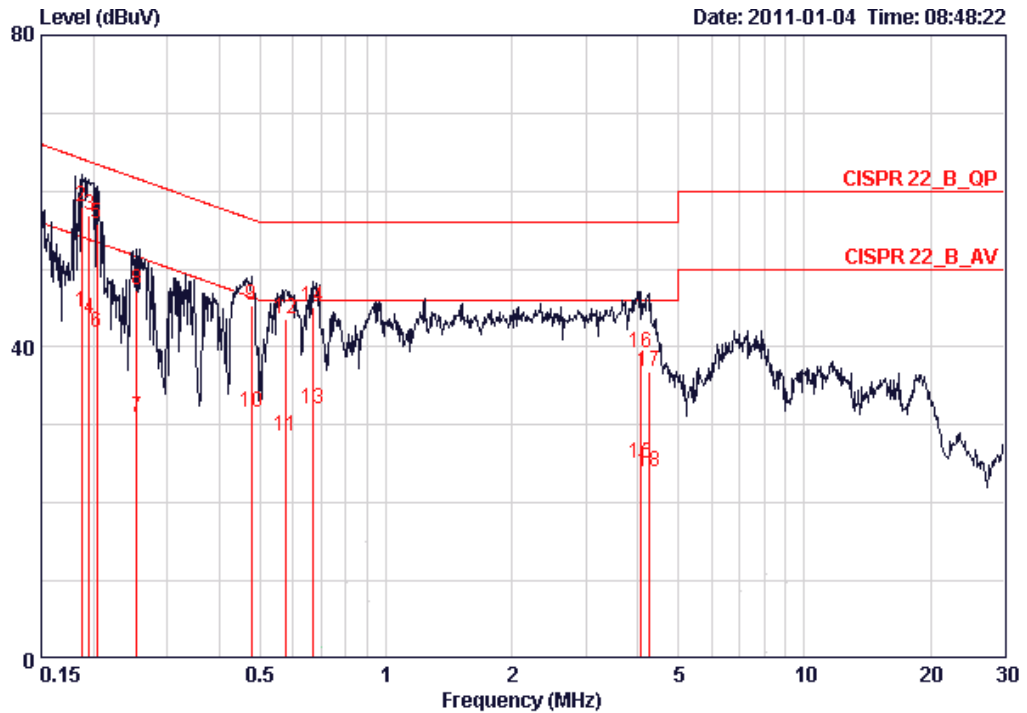

	Freq	Level	Over Limit	Limit Line	Read Level	LISN Factor	Cable Loss	Remark
	MHz	dBuV	dB	dBuV	dBuV	dB	dB	
1	0.18739	44.48	-9.68	54.15	44.22	0.06	0.20	AVERAGE
2	0.18739	57.88	-6.28	64.15	57.62	0.06	0.20	QP
3	0.19550	56.94	-6.86	63.80	56.69	0.05	0.20	QP
4	0.19550	43.50	-10.30	53.80	43.25	0.05	0.20	AVERAGE
5	0.20396	55.82	-7.63	63.45	55.57	0.05	0.20	QP
6	0.20396	41.76	-11.69	53.45	41.51	0.05	0.20	AVERAGE
7	0.25345	31.04	-20.60	51.64	30.80	0.04	0.20	AVERAGE
8	0.25345	47.27	-14.37	61.64	47.03	0.04	0.20	QP
9	0.47612	45.25	-11.16	56.41	45.05	0.03	0.17	QP
10	0.47612	31.53	-14.88	46.41	31.33	0.03	0.17	AVERAGE
11	0.57617	28.62	-17.38	46.00	28.39	0.03	0.20	AVERAGE
12	0.57617	43.61	-12.39	56.00	43.38	0.03	0.20	QP
13	0.67187	32.15	-13.85	46.00	31.92	0.03	0.20	AVERAGE
14	0.67187	45.12	-10.88	56.00	44.89	0.03	0.20	QP
15	4.070	25.04	-20.96	46.00	24.63	0.11	0.30	AVERAGE
16	4.070	39.22	-16.78	56.00	38.81	0.11	0.30	QP
17	4.247	36.91	-19.09	56.00	36.49	0.12	0.30	QP
18	4.247	24.06	-21.94	46.00	23.64	0.12	0.30	AVERAGE

Temperature	23°C	Humidity	54%
Test Engineer	Peter Wu	Phase	Neutral
Configuration	Mode 2		

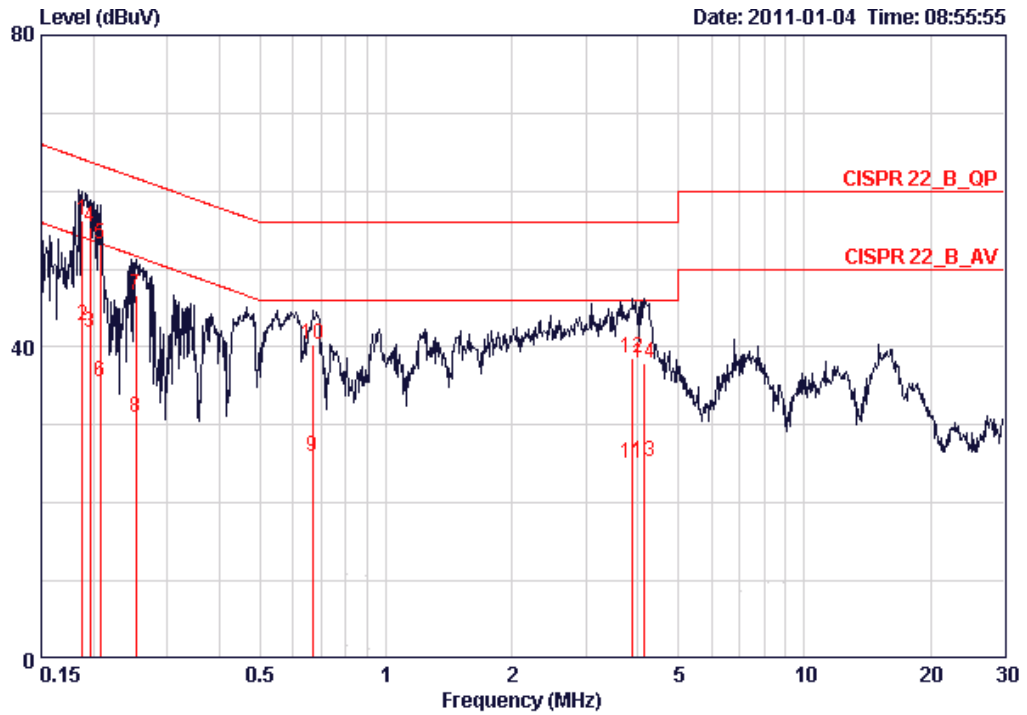

	Freq	Level	Over Limit	Limit Line	Read Level	LISN Factor	Cable Loss	Remark
	MHz	dBuV	dB	dBuV	dBuV	dB	dB	
1	0.18838	56.23	-7.87	64.11	55.95	0.08	0.20	QP
2	0.18838	42.74	-11.36	54.11	42.46	0.08	0.20	AVERAGE
3	0.19654	41.79	-11.96	53.76	41.51	0.08	0.20	AVERAGE
4	0.19654	55.36	-8.39	63.76	55.08	0.08	0.20	QP
5	0.20723	53.21	-10.11	63.32	52.93	0.08	0.20	QP
6	0.20723	35.45	-17.87	53.32	35.17	0.08	0.20	AVERAGE
7	0.25211	46.60	-15.09	61.69	46.32	0.08	0.20	QP
8	0.25211	31.02	-20.67	51.69	30.74	0.08	0.20	AVERAGE
9	0.66832	25.91	-20.09	46.00	25.64	0.07	0.20	AVERAGE
10	0.66832	40.22	-15.78	56.00	39.95	0.07	0.20	QP
11	3.881	25.02	-20.98	46.00	24.58	0.14	0.30	AVERAGE
12	3.881	38.65	-17.35	56.00	38.21	0.14	0.30	QP
13	4.136	25.39	-20.61	46.00	24.94	0.15	0.30	AVERAGE
14	4.136	38.00	-18.00	56.00	37.55	0.15	0.30	QP

Note: Level = Read Level + LISN Factor + Cable Loss.

4.2. 99% Occupied Bandwidth Measurement

4.2.1. Limit

No restriction limits. But resolution bandwidth within band edge measurement is 1% of the 99% occupied bandwidth.

4.2.2. Measuring Instruments and Setting

Please refer to section 5 of equipments list in this report. The following table is the setting of the spectrum analyzer.

Spectrum Parameters	Setting
Attenuation	Auto
Span Frequency	> 26dB Bandwidth
RB	300 kHz
VB	1000 kHz
Detector	Peak
Trace	Max Hold
Sweep Time	Auto

4.2.3. Test Procedures

1. The transmitter output (antenna port) was connected to the spectrum analyzer in peak hold mode.
2. The resolution bandwidth of 300 kHz and the video bandwidth of 1000 kHz were used.
3. Measured the spectrum width with power higher than 26dB below carrier.
4. Measuring multiple antennas, the connector is required to link with spectrum analyzer through a combiner.

4.2.4. Test Setup Layout

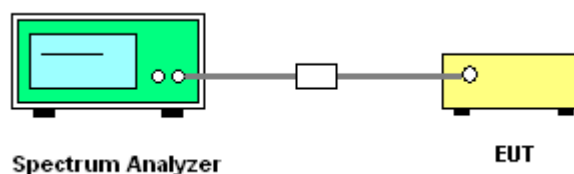

4.2.5. Test Deviation

There is no deviation with the original standard.

4.2.6. EUT Operation during Test

The EUT was programmed to be in continuously transmitting mode.

4.2.7. Test Result of 99% Occupied Bandwidth

Temperature	20°C	Humidity	61%
Test Engineer	Johnson Chang	Configurations	IEEE 802.11n

Configuration IEEE 802.11n MCS0 20MHz Ant. 1 + Ant. 2

Channel	Frequency	26dB Bandwidth (MHz)	99% Occupied Bandwidth (MHz)
36	5180 MHz	22.24	17.12
40	5200 MHz	19.68	17.28
48	5240 MHz	19.36	17.12

Configuration IEEE 802.11n MCS0 40MHz Ant. 1 + Ant. 2

Channel	Frequency	26dB Bandwidth (MHz)	99% Occupied Bandwidth (MHz)
38	5190 MHz	39.20	36.64
46	5230 MHz	57.44	36.64

Temperature	20°C	Humidity	61%
Test Engineer	Johnson Chang	Configurations	IEEE 802.11a

Configuration IEEE 802.11a Ant. 1 + Ant. 2

Channel	Frequency	26dB Bandwidth (MHz)	99% Occupied Bandwidth (MHz)
36	5180 MHz	20.00	16.00
40	5200 MHz	20.00	16.16
48	5240 MHz	19.04	16.00

26 dB Bandwidth Plot on Configuration IEEE 802.11n MCS0 20MHz Ant. 1 + Ant. 2 / 5180 MHz

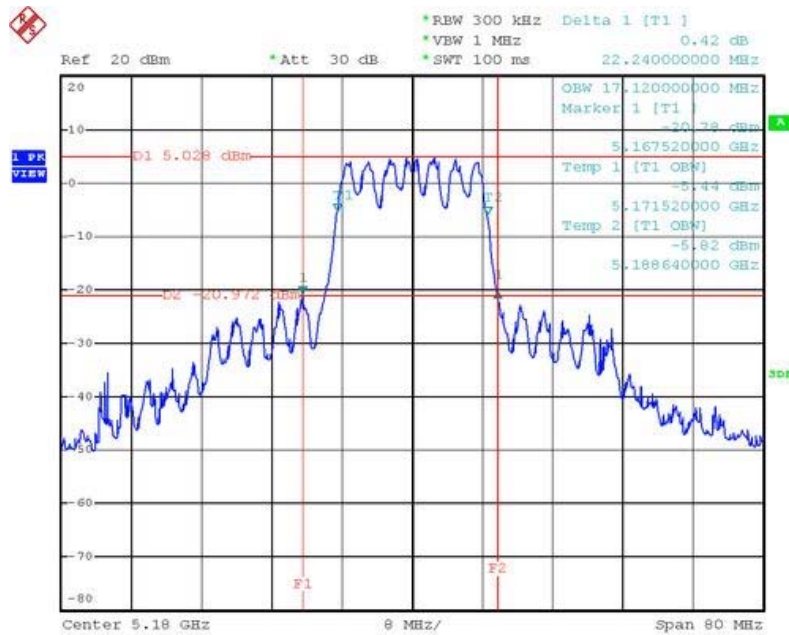

Date: 21.JAN.2011 15:09:58

26 dB Bandwidth Plot on Configuration IEEE 802.11n MCS0 20MHz Ant. 1 + Ant. 2 / 5200 MHz

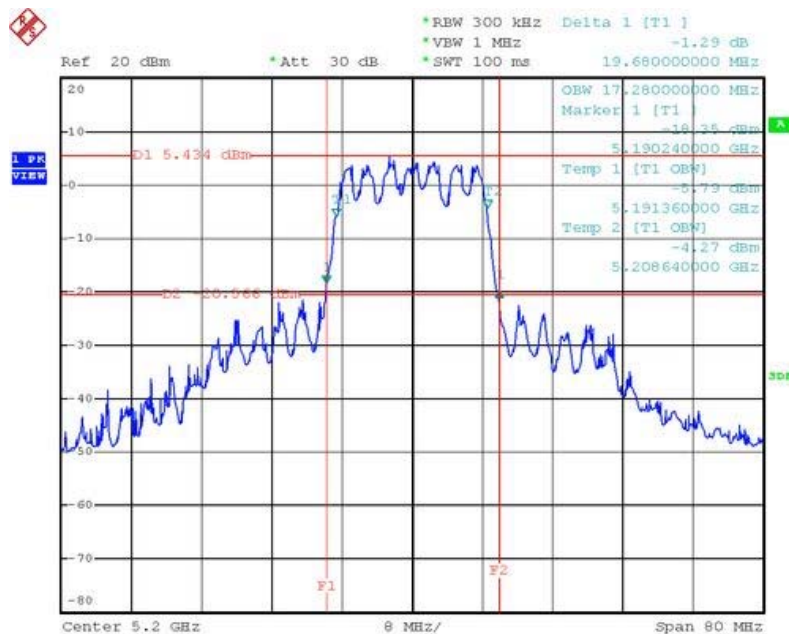

Date: 21.JAN.2011 15:04:41

26 dB Bandwidth Plot on Configuration IEEE 802.11n MCS0 20MHz Ant. 1 + Ant. 2 / 5240 MHz

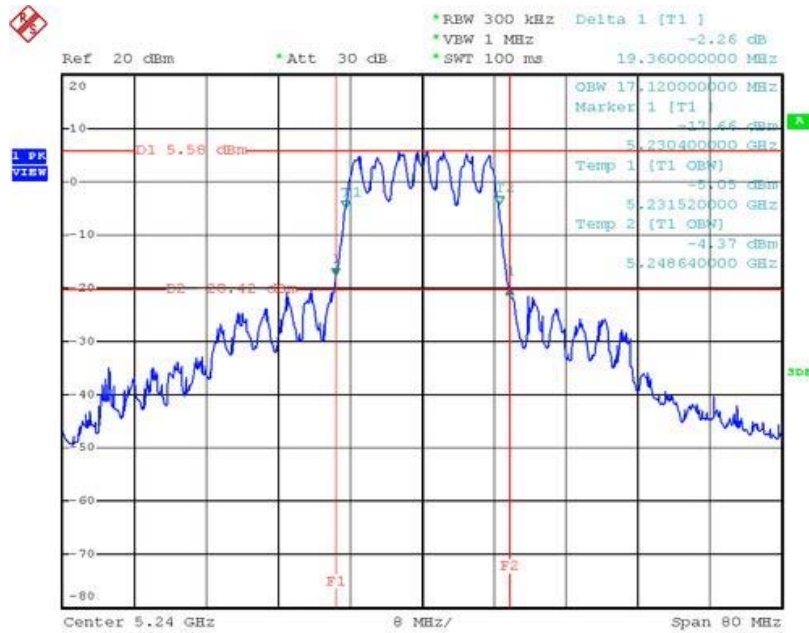

Date: 21.JAN.2011 15:03:37

26 dB Bandwidth Plot on Configuration IEEE 802.11n MCS0 40MHz Ant. 1 + Ant. 2 / 5190 MHz

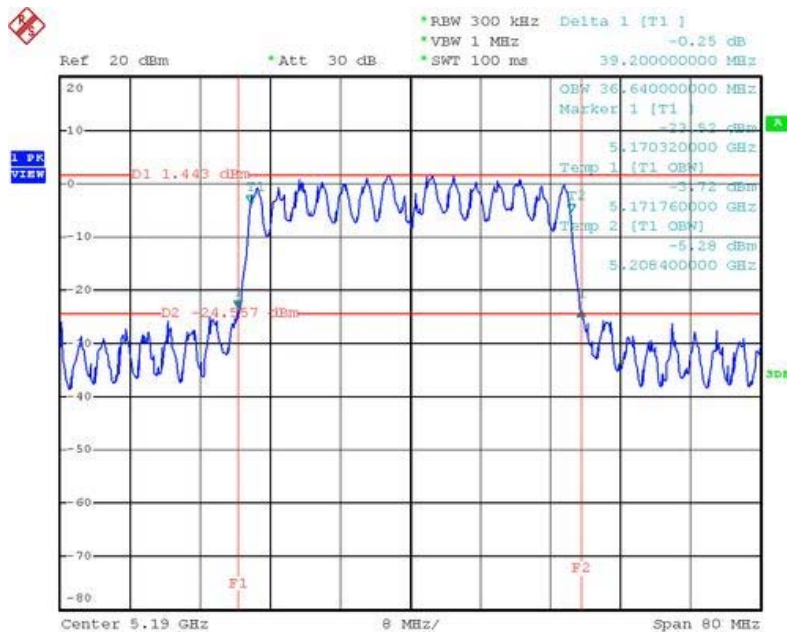

Date: 21.JAN.2011 15:11:26

26 dB Bandwidth Plot on Configuration IEEE 802.11n MCS0 40MHz Ant. 1 + Ant. 2 / 5230 MHz

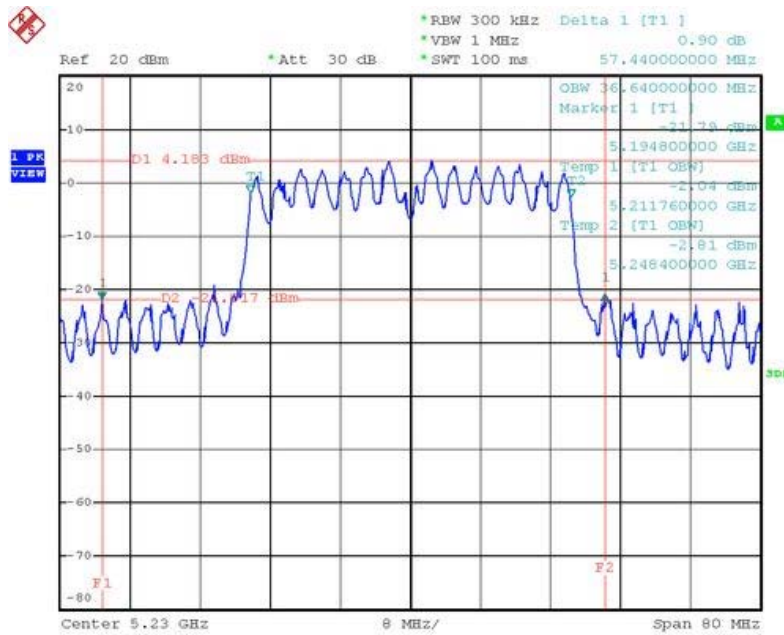

Date: 21.JAN.2011 15:13:02

26 dB Bandwidth Plot on Configuration IEEE 802.11a Ant. 1 + Ant. 2 / 5180 MHz

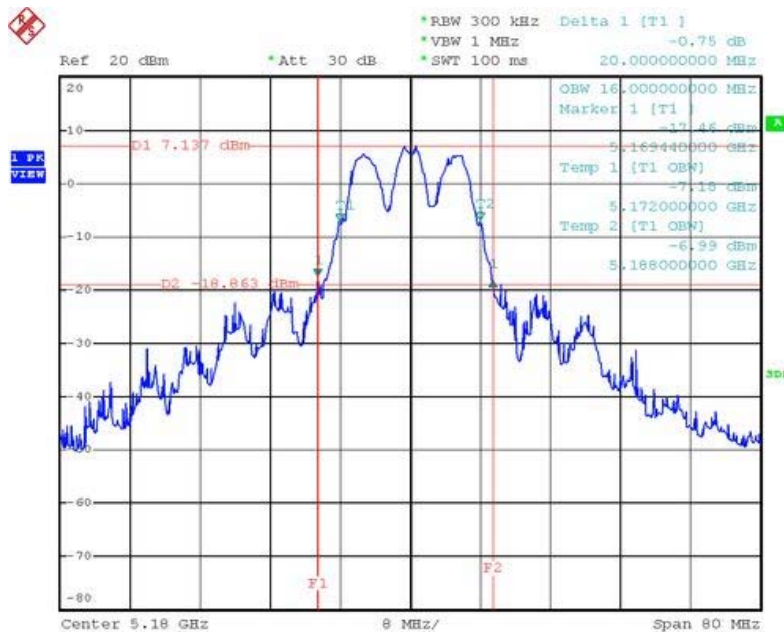

Date: 21.JAN.2011 15:38:18

26 dB Bandwidth Plot on Configuration IEEE 802.11a Ant. 1 + Ant. 2 / 5200 MHz

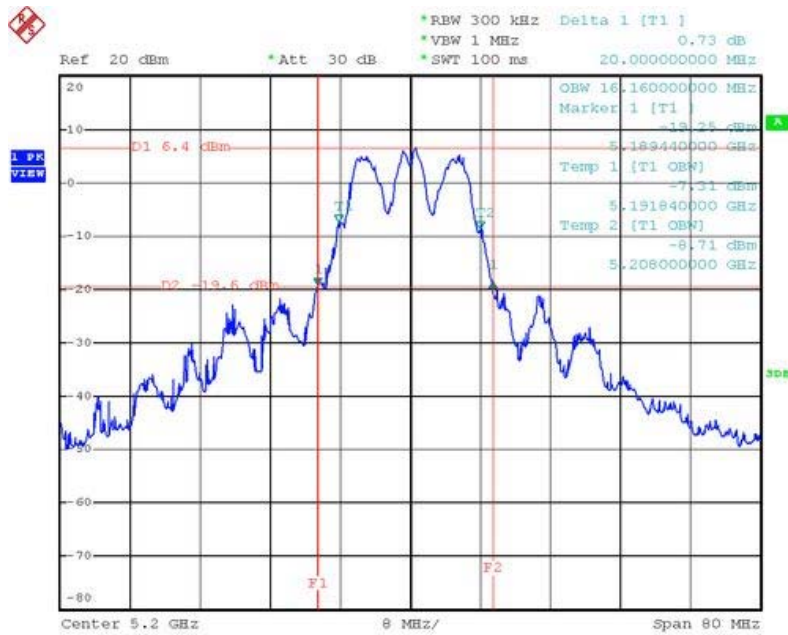

Date: 21.JAN.2011 14:46:35

26 dB Bandwidth Plot on Configuration IEEE 802.11a Ant. 1 + Ant. 2 / 5240 MHz

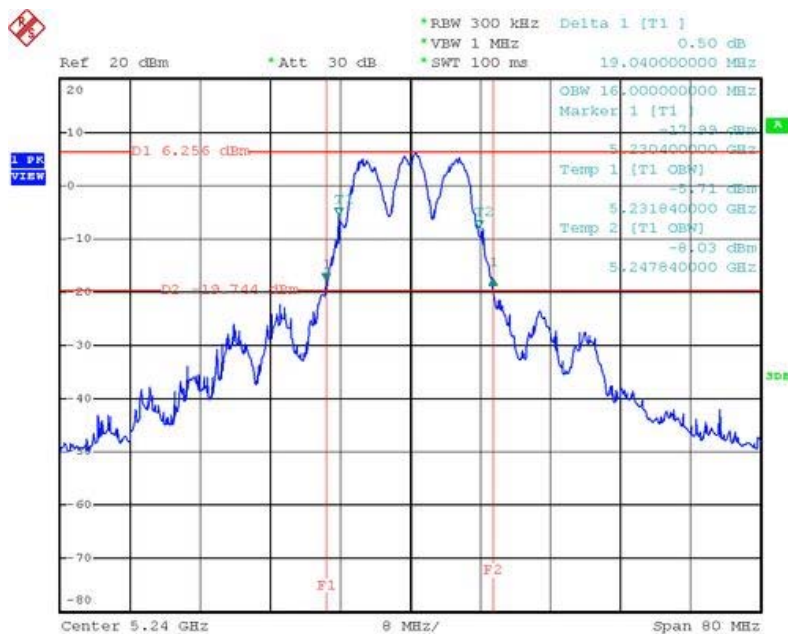

Date: 21.JAN.2011 14:47:37

4.3. Maximum Conducted Output Power Measurement

4.3.1. Limit

For the band 5.15~5.25 GHz, the maximum conducted output power over the frequency band of operation shall not exceed the lesser of 50 mW (17dBm) or $4 \text{ dBm} + 10\log B$, where B is the 26 dB emissions bandwidth in MHz. If transmitting antennas of directional gain greater than 6 dBi are used, the peak output power and power density from the intentional radiator shall be reduced by the amount in dB that the directional gain of the antenna exceeds 6 dBi.

4.3.2. Measuring Instruments and Setting

The following table is the setting of the peak power meter.

Power Meter Parameter	Setting
Bandwidth	50MHz bandwidth is greater than the EUT emission bandwidth
Detector	AVERAGE

4.3.3. Test Procedures

Spectrum Parameter	Setting
RF Output Power Method	<input checked="" type="checkbox"/> ANSI C63.10 clause 6.10.2.1 (a) power meter method
RF Output Power Method	<input type="checkbox"/> ANSI C63.10 clause 6.10.2.1 (b) channel integration method
RF Output Power Method	<input type="checkbox"/> ANSI C63.10 clause 6.10.3.1 Method 1 - spectral trace averaging
RF Output Power Method	<input type="checkbox"/> ANSI C63.10 clause 6.10.3.2 Method 2 - zero-span mode with trace averaging

4.3.4. Test Setup Layout

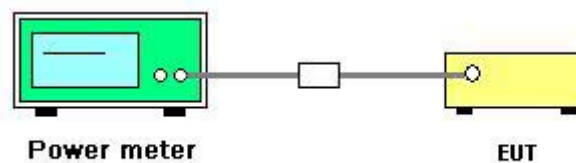

4.3.5. Test Deviation

There is no deviation with the original standard.

4.3.6. EUT Operation during Test

The EUT was programmed to be in continuously transmitting mode.

4.3.7. Test Result of Maximum Conducted Output Power

Temperature	20°C	Humidity	61%
Test Engineer	Johnson Chang	Configurations	IEEE 802.11n
Test Date	Jan. 21, 2011		

Configuration IEEE 802.11n MCS0 20MHz Ant. 1

Channel	Frequency	Conducted Power (dBm)	Max. Limit (dBm)	Result
36	5180 MHz	13.88	17.00	Complies
40	5200 MHz	13.44	17.00	Complies
48	5240 MHz	13.35	17.00	Complies

Configuration IEEE 802.11n MCS0 20MHz Ant. 2

Channel	Frequency	Conducted Power (dBm)	Max. Limit (dBm)	Result
36	5180 MHz	13.05	17.00	Complies
40	5200 MHz	13.02	17.00	Complies
48	5240 MHz	14.16	17.00	Complies

Configuration IEEE 802.11n MCS0 20MHz Ant. 1 + Ant. 2

Channel	Frequency	Conducted Power (dBm)	Max. Limit (dBm)	Result
36	5180 MHz	16.50	17.00	Complies
40	5200 MHz	16.25	17.00	Complies
48	5240 MHz	16.78	17.00	Complies

Configuration IEEE 802.11n MCS0 40MHz Ant. 1

Channel	Frequency	Conducted Power (dBm)	Max. Limit (dBm)	Result
38	5190 MHz	11.05	17.00	Complies
46	5230 MHz	13.27	17.00	Complies

Configuration IEEE 802.11nMCS0 40MHz Ant. 2

Channel	Frequency	Conducted Power (dBm)	Max. Limit (dBm)	Result
38	5190 MHz	11.59	17.00	Complies
46	5230 MHz	13.88	17.00	Complies

Configuration IEEE 802.11n MCS0 40MHz Ant. 1 + Ant. 2

Channel	Frequency	Conducted Power (dBm)	Max. Limit (dBm)	Result
38	5190 MHz	14.34	17.00	Complies
46	5230 MHz	16.60	17.00	Complies

Temperature	20°C	Humidity	61%
Test Engineer	Johnson Chang	Configurations	IEEE 802.11a
Test Date	Jan. 21, 2011		

Configuration IEEE 802.11a Ant. 1

Channel	Frequency	Conducted Power (dBm)	Max. Limit (dBm)	Result
36	5180 MHz	14.20	17.00	Complies
40	5200 MHz	13.48	17.00	Complies
48	5240 MHz	13.27	17.00	Complies

Configuration IEEE 802.11a Ant. 2

Channel	Frequency	Conducted Power (dBm)	Max. Limit (dBm)	Result
36	5180 MHz	13.68	17.00	Complies
40	5200 MHz	14.22	17.00	Complies
48	5240 MHz	13.37	17.00	Complies

Configuration IEEE 802.11a Ant. 1 + Ant. 2

Channel	Frequency	Conducted Power (dBm)	Max. Limit (dBm)	Result
36	5180 MHz	16.96	17.00	Complies
40	5200 MHz	16.88	17.00	Complies
48	5240 MHz	16.33	17.00	Complies

4.4. Power Spectral Density Measurement

4.4.1. Limit

The power spectral density is defined as the highest level of power in dBm per MHz generated by the transmitter within the power envelope. The following table is power spectral density limits and decrease power density limit rule refer to section 4.3.1.

Frequency Range	Power Spectral Density limit (dBm/MHz)
5.15~5.25 GHz	4

4.4.2. Measuring Instruments and Setting

Please refer to section 5 of equipments list in this report. The following table is the setting of the spectrum analyzer.

Spectrum Parameter	Setting
Attenuation	Auto
Span Frequency	Encompass the entire emissions bandwidth (EBW) of the signal
RB	1000 kHz
VB	3000 kHz
Detector	SAMPLE
Trace	AVERAGE
Sweep Time	Auto
Trace Average	100 times

4.4.3. Test Procedures

1. The transmitter output (antenna port) was connected to the spectrum analyzer.
2. Set RBW of spectrum analyzer to 1000kHz and VBW to 3000kHz. Set Detector to Peak, Trace to Max Hold. Mark the frequency with maximum peak power as the center of the display of the spectrum.
3. Measuring multiple antennas, the connector is required to link with spectrum analyzer through a combiner.

4.4.4. Test Setup Layout

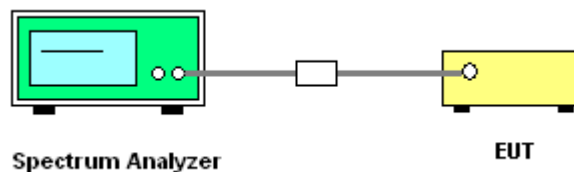

4.4.5. Test Deviation

There is no deviation with the original standard.

4.4.6. EUT Operation during Test

The EUT was programmed to be in continuously transmitting mode.

4.4.7. Test Result of Power Spectral Density

Temperature	20°C	Humidity	61%
Test Engineer	Johnson Chang	Configurations	IEEE 802.11n

Configuration IEEE 802.11n MCS0 20MHz Ant. 1 + Ant. 2

Channel	Frequency	Power Density (dBm)	Max. Limit (dBm)	Result
36	5180 MHz	0.50	4.00	Complies
40	5200 MHz	-4.97	4.00	Complies
48	5240 MHz	1.27	4.00	Complies

Configuration IEEE 802.11n MCS0 40MHz Ant. 1 + Ant. 2

Channel	Frequency	Power Density (dBm)	Max. Limit (dBm)	Result
38	5190 MHz	-5.50	4.00	Complies
46	5230 MHz	-6.38	4.00	Complies

Temperature	20°C	Humidity	61%
Test Engineer	Johnson Chang	Configurations	IEEE 802.11a

Configuration IEEE 802.11a Ant. 1 + Ant. 2

Channel	Frequency	Power Density (dBm)	Max. Limit (dBm)	Result
36	5180 MHz	3.34	4.00	Complies
40	5200 MHz	-0.93	4.00	Complies
48	5240 MHz	-0.66	4.00	Complies

Note: All the test values were listed in the report.

For plots, only the worse case of OFDM modulation was listed in the report.

Power Density Plot on Configuration IEEE 802.11a Ant. 1 + Ant. 2 / 5180 MHz

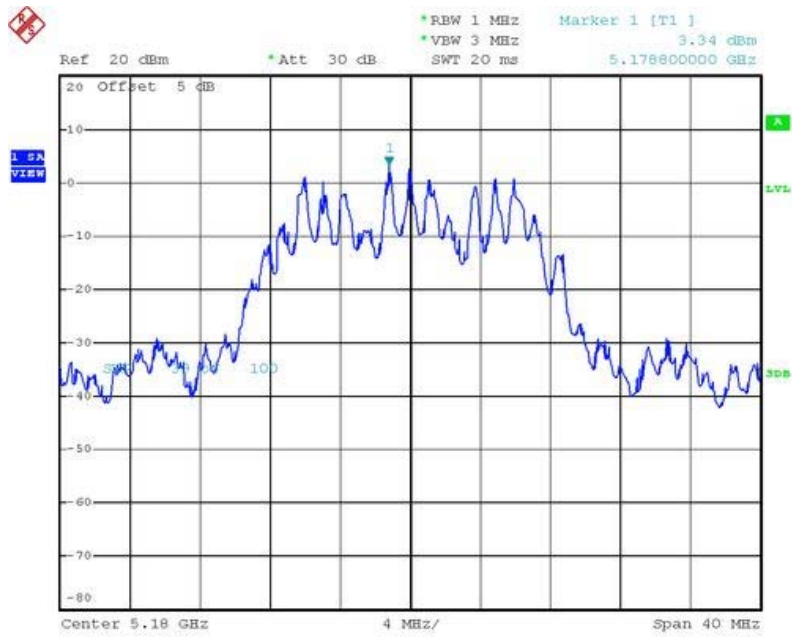

Date: 21.JAN.2011 15:38:27

Power Density Plot on Configuration IEEE 802.11a Ant. 1 + Ant. 2 / 5200 MHz

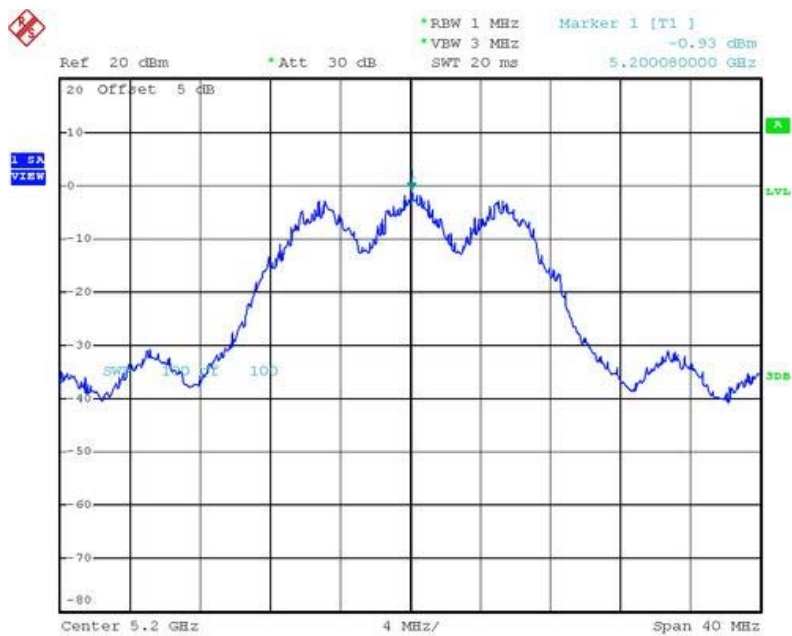

Date: 21.JAN.2011 14:46:44

Power Density Plot on Configuration IEEE 802.11a Ant. 1 + Ant. 2 / 5240 MHz

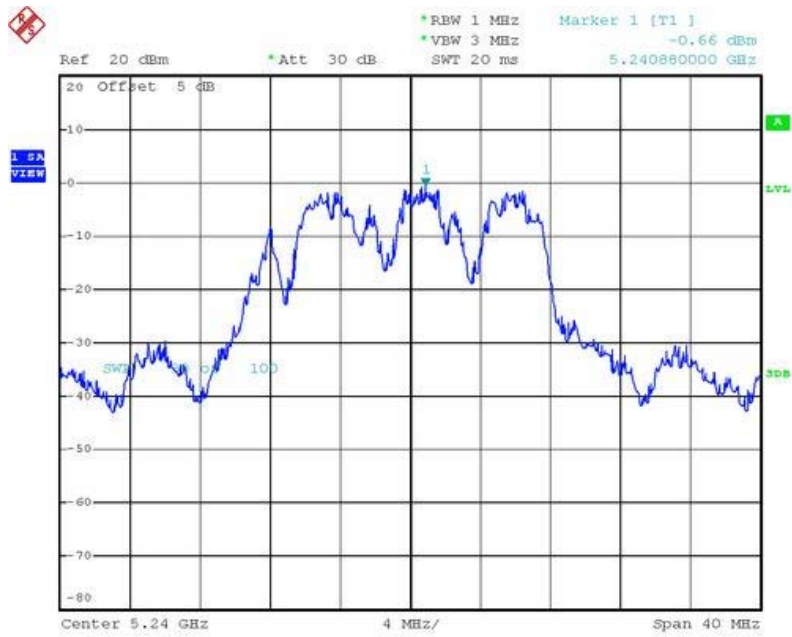

Date: 21.JAN.2011 14:47:46

4.5. Peak Excursion Measurement

4.5.1. Limit

The ratio of the peak excursion of the modulation envelope (measured using a peak hold function) to the maximum conducted output power (measured as specified above) shall not exceed 13 dB across any 1 MHz bandwidth or the emissions bandwidth whichever is less.

4.5.2. Measuring Instruments and Setting

Please refer to section 5 of equipments list in this report. The following table is the setting of the spectrum analyzer.

Spectrum Parameter	Setting
Attenuation	Auto
Span Frequency	Encompass the entire emissions bandwidth (EBW) of the signal
RB	1000 kHz (Peak Trace) / 1000 kHz (Average Trace)
VB	3000 kHz (Peak Trace) / 300 kHz (Average Trace)
Detector	Peak (Peak Trace) / Sample (Average Trace)
Trace	Max Hold
Sweep Time	60s

4.5.3. Test Procedures

1. The transmitter output (antenna port) was connected to the spectrum analyzer.
2. Set the spectrum analyzer span to view the entire emissions bandwidth. The largest difference between the following two traces (Peak Trace and Average Trace) must be ≤ 13 dB for all frequencies across the emissions bandwidth. Submit a plot.
3. Peak Trace: Set RBW = 1 MHz, VBW ≥ 3 MHz with peak detector and max-hold settings.
4. Average Trace: Method #3—video averaging with max hold--and sum power across the band. Set span to encompass the entire emissions bandwidth (EBW) of the signal. Set sweep trigger to "free run". Set RBW = 1 MHz. Set VBW $\geq 1/T$ (IEEE 802.11nVBW = 300kHz $\geq 1/4\mu$ s). Use sample detector mode if bin width (i.e., span/number of points in spectrum) < 0.5 RBW. Otherwise use peak detector mode. Set max hold. Allow max hold to run for 60 seconds.
5. Measuring multiple antennas, the connector is required to link with spectrum analyzer through a combiner.

4.5.4. Test Setup Layout

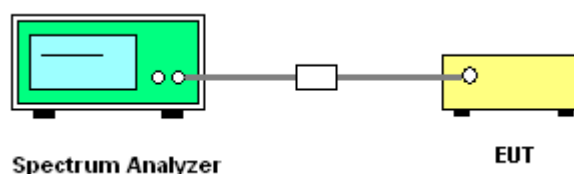

4.5.5. Test Deviation

There is no deviation with the original standard.

4.5.6. EUT Operation during Test

The EUT was programmed to be in continuously transmitting mode.

4.5.7. Test Result of Peak Excursion

Temperature	20°C	Humidity	61%
Test Engineer	Johnson Chang	Configurations	IEEE 802.11n

Configuration IEEE 802.11n MCS0 20MHz Ant. 1 + Ant. 2

Channel	Frequency	Peak Excursion (dB)	Max. Limit (dB)	Result
36	5180 MHz	5.48	13	Complies
40	5200 MHz	5.32	13	Complies
48	5240 MHz	6.26	13	Complies

Configuration IEEE 802.11n MCS0 40MHz Ant. 1 + Ant. 2

Channel	Frequency	Peak Excursion (dB)	Max. Limit (dB)	Result
38	5190 MHz	5.14	13	Complies
46	5230 MHz	5.70	13	Complies

Temperature	20°C	Humidity	61%
Test Engineer	Johnson Chang	Configurations	IEEE 802.11a

Configuration IEEE 802.11a Ant. 1 + Ant. 2

Channel	Frequency	Peak Excursion (dB)	Max. Limit (dB)	Result
36	5180 MHz	5.77	13	Complies
40	5200 MHz	5.18	13	Complies
48	5240 MHz	5.43	13	Complies

Note: All the test values were listed in the report.

For plots, only the worse case of OFDM modulation was listed in the report.

Peak Excursion Plot on Configuration IEEE 802.11n MCS0 20MHz Ant. 1 + Ant. 2 / 5180 MHz

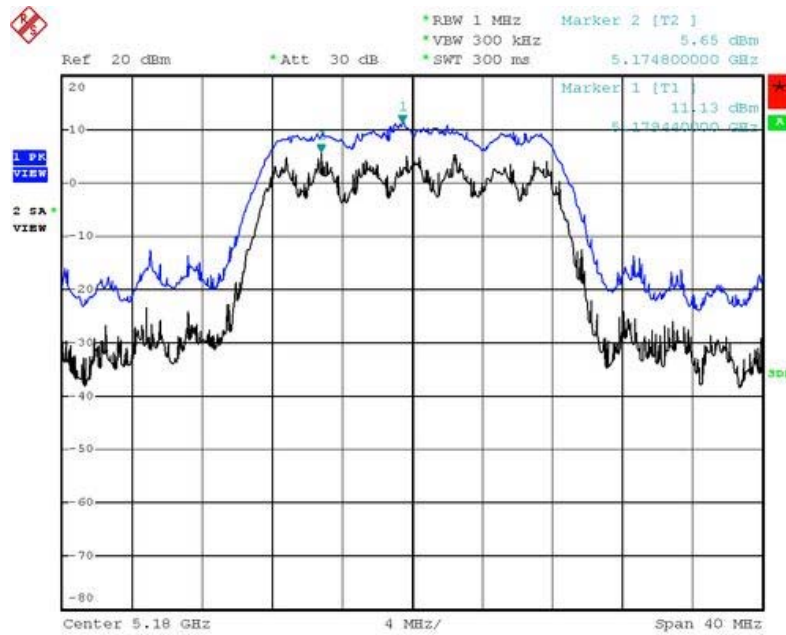

Date: 21.JAN.2011 15:10:21

Peak Excursion Plot on Configuration IEEE 802.11n MCS0 20MHz Ant. 1 + Ant. 2 / 5200 MHz

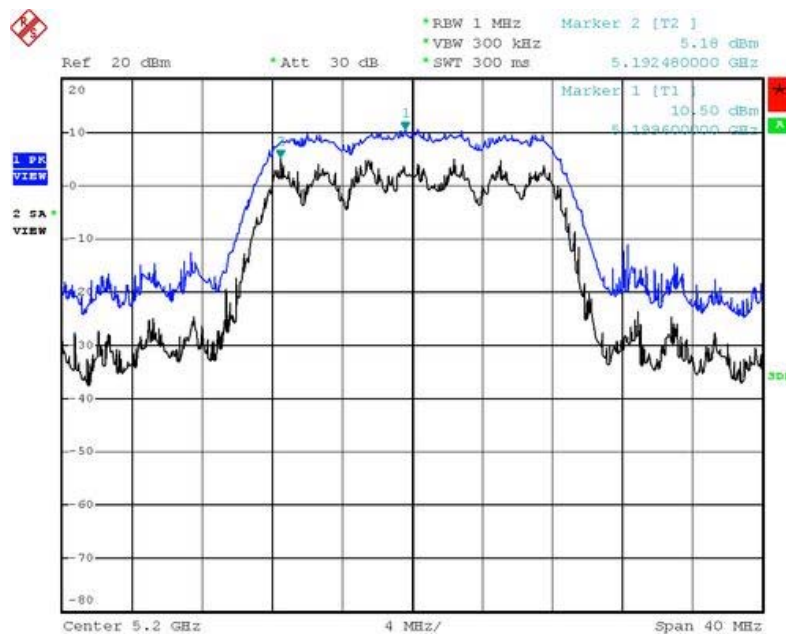

Date: 21.JAN.2011 15:05:05

Peak Excursion Plot on Configuration IEEE 802.11n MCS0 20MHz Ant. 1 + Ant. 2 / 5240 MHz

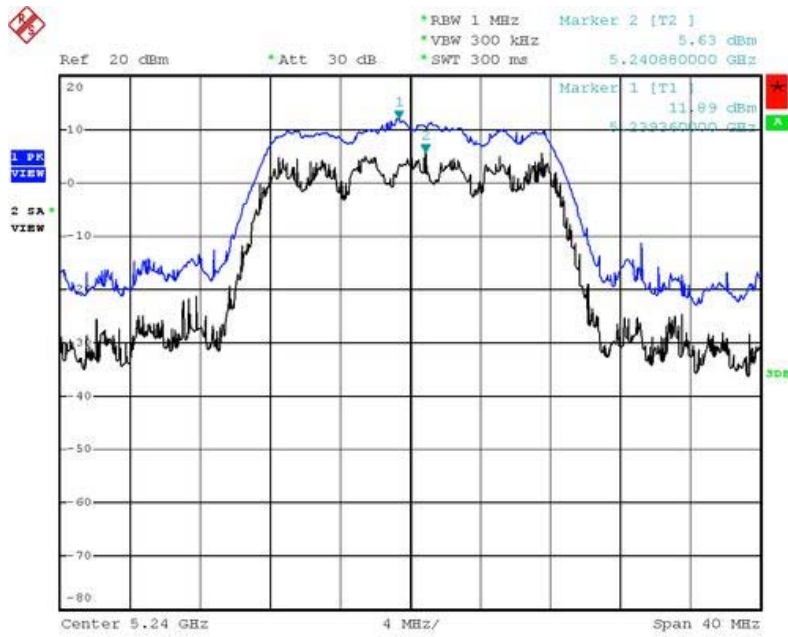

Date: 21.JAN.2011 15:04:01

4.6. Radiated Emissions Measurement

4.6.1. Limit

For transmitters operating in the 5.15-5.25 GHz band: all emissions outside of the 5.15-5.25 GHz band shall not exceed an EIRP of -27 dBm/MHz (68.3dBuV/m at 3m). In addition, In case the emission fall within the restricted band specified on 15.205(a), then the 15.209(a) limit in the table below has to be followed.

Frequencies (MHz)	Field Strength (micorvolts/meter)	Measurement Distance (meters)
0.009~0.490	2400/F(KHz)	300
0.490~1.705	24000/F(KHz)	30
1.705~30.0	30	30
30~88	100	3
88~216	150	3
216~960	200	3
Above 960	500	3

4.6.2. Measuring Instruments and Setting

Please refer to section 5 of equipments list in this report. The following table is the setting of spectrum analyzer and receiver.

Spectrum Parameter	Setting
Attenuation	Auto
Start Frequency	1000 MHz
Stop Frequency	40 GHz
RB / VB (Emission in restricted band)	1MHz / 1MHz for Peak, 1 MHz / 10Hz for Average
RB / VB (Emission in non-restricted band)	1000KHz / 1000KHz for peak

Receiver Parameter	Setting
Attenuation	Auto
Start ~ Stop Frequency	9kHz~150kHz / RB 200Hz for QP
Start ~ Stop Frequency	150kHz~30MHz / RB 9kHz for QP
Start ~ Stop Frequency	30MHz~1000MHz / RB 120kHz for QP

4.6.3. Test Procedures

1. Configure the EUT according to ANSI C63.4. The EUT was placed on the top of the turntable 0.8 meter above ground. The phase center of the receiving antenna mounted on the top of a height-variable antenna tower was placed 3 meters far away from the turntable.
2. Power on the EUT and all the supporting units. The turntable was rotated by 360 degrees to determine the position of the highest radiation.
3. The height of the broadband receiving antenna was varied between one meter and four meters above ground to find the maximum emissions field strength of both horizontal and vertical polarization.
4. For each suspected emissions, the antenna tower was scan (from 1 M to 4 M) and then the turntable was rotated (from 0 degree to 360 degrees) to find the maximum reading.
5. Set the test-receiver system to Peak or CISPR quasi-peak Detect Function with specified bandwidth under Maximum Hold Mode.
6. For emissions above 1GHz, use 1MHz VBW and RBW for peak reading. Then 1MHz RBW and 10Hz VBW for average reading in spectrum analyzer.
7. When the radiated emissions limits are expressed in terms of the average value of the emissions, and pulsed operation is employed, the measurement field strength shall be determined by averaging over one complete pulse train, including blanking intervals, as long as the pulse train does not exceed 0.1 seconds. As an alternative (provided the transmitter operates for longer than 0.1 seconds) or in cases where the pulse train exceeds 0.1 seconds, the measured field strength shall be determined from the average absolute voltage during a 0.1 second interval during which the field strength is at its maximum value.
8. If the emissions level of the EUT in peak mode was 3 dB lower than the average limit specified, then testing will be stopped and peak values of EUT will be reported, otherwise, the emissions which do not have 3 dB margin will be repeated one by one using the quasi-peak method for below 1GHz.
9. For testing above 1GHz, the emissions level of the EUT in peak mode was lower than average limit (that means the emissions level in peak mode also complies with the limit in average mode), then testing will be stopped and peak values of EUT will be reported, otherwise, the emissions will be measured in average mode again and reported.
10. In case the emission is lower than 30MHz, loop antenna has to be used for measurement and the recorded data should be QP measured by receiver. High – Low scan is not required in this case.

4.6.4. Test Setup Layout

For radiated emissions below 30MHz

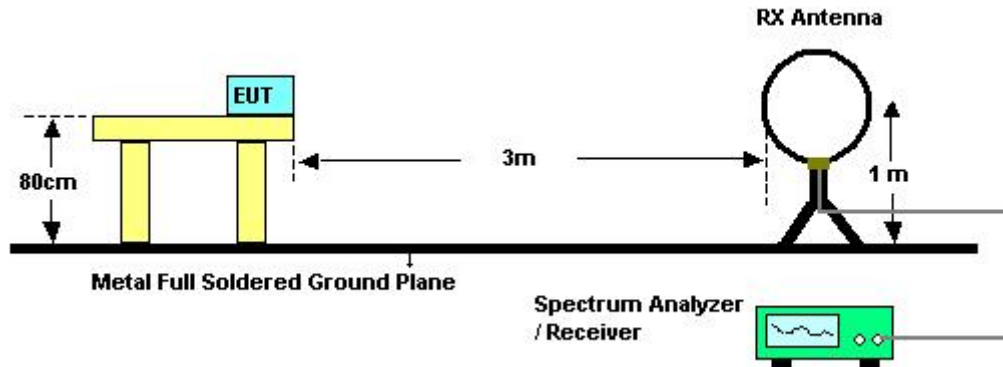

For radiated emissions above 30MHz

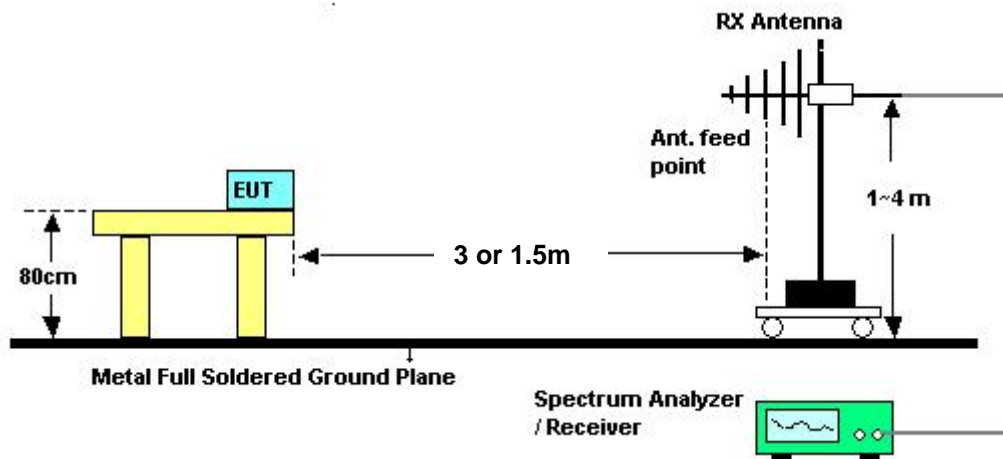

Above 5GHz shall be extrapolated to the specified distance using an extrapolation factor of 20 dB/decade from 3m to 1.5m.

Distance extrapolation factor = $20 \log (\text{specific distance [3m]} / \text{test distance [1.5m]})$ (dB);

Limit line = specific limits (dBuV) + distance extrapolation factor [6 dB].

4.6.5. Test Deviation

There is no deviation with the original standard.

4.6.6. EUT Operation during Test

The EUT was programmed to be in continuously transmitting mode.

4.6.7. Results of Radiated Emissions (9kHz~30MHz)

Temperature	21°C	Humidity	57%
Test Engineer	Sean Ku	Test Date	Feb. 18, 2011

Freq. (MHz)	Level (dBuV)	Over Limit (dB)	Limit Line (dBuV)	Remark
-	-	-	-	See Note

Note:

The amplitude of spurious emissions that are attenuated by more than 20dB below the permissible value has no need to be reported.

Distance extrapolation factor = $40 \log(\text{specific distance} / \text{test distance})$ (dB);

Limit line = specific limits (dBuV) + distance extrapolation factor.

4.6.8. Results of Radiated Emissions (30MHz~1GHz)

Temperature	21°C	Humidity	57%
Test Engineer	Sean Ku	Configurations	Mode 3

Horizontal

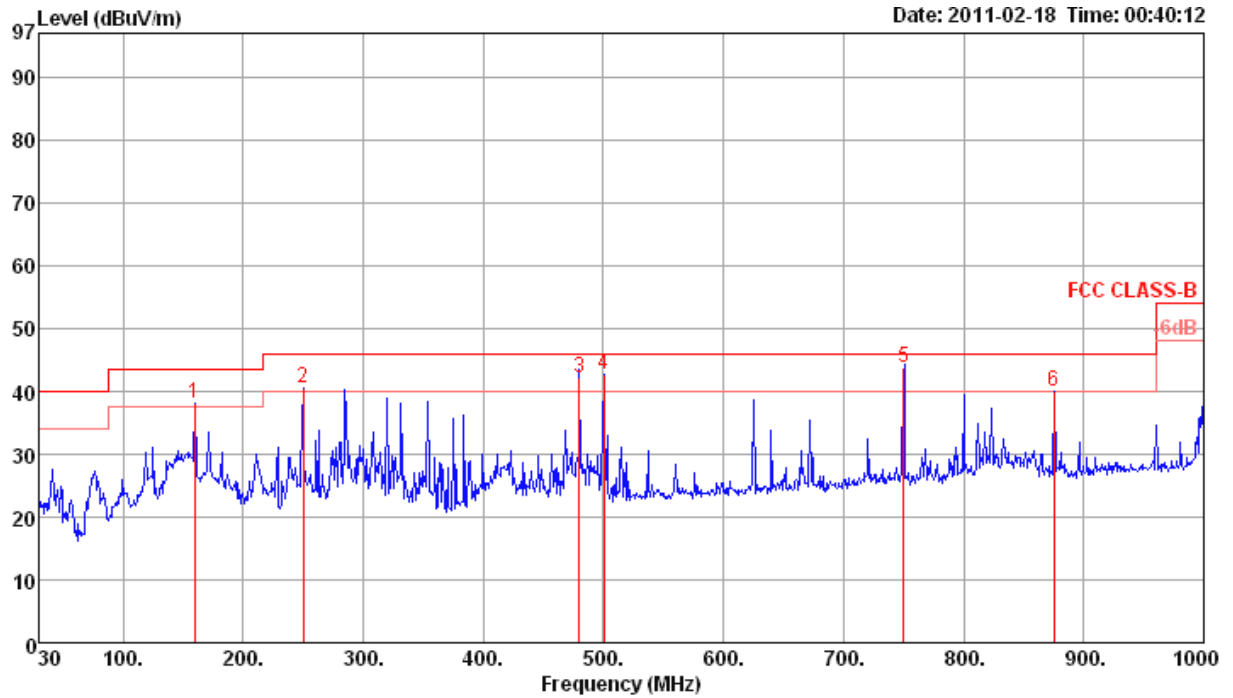

	Freq	Level	Limit	Over	Read	Cable	Preamp	Antenna	T/Pos	A/Pos	Remark	Pol/Phase
	MHz	dBuV/m	dBuV/m	dB	dBuV	Loss	Factor	Factor	deg	cm		
1	159.98	38.20	43.50	-5.30	51.97	1.50	27.30	12.03	0	100	Peak	HORIZONTAL
2	250.19	40.52	46.00	-5.48	52.85	1.90	27.00	12.77	0	100	Peak	HORIZONTAL
3	480.08	42.23	46.00	-3.77	50.26	2.66	28.00	17.31	98	100	QP	HORIZONTAL
4	500.45	42.74	46.00	-3.26	50.51	2.70	28.10	17.63	0	100	Peak	HORIZONTAL
5	749.99	43.83	46.00	-2.17	48.70	3.50	27.80	19.43	14	100	QP	HORIZONTAL
6	874.87	40.01	46.00	-5.99	43.62	3.50	27.45	20.34	0	100	Peak	HORIZONTAL

Vertical

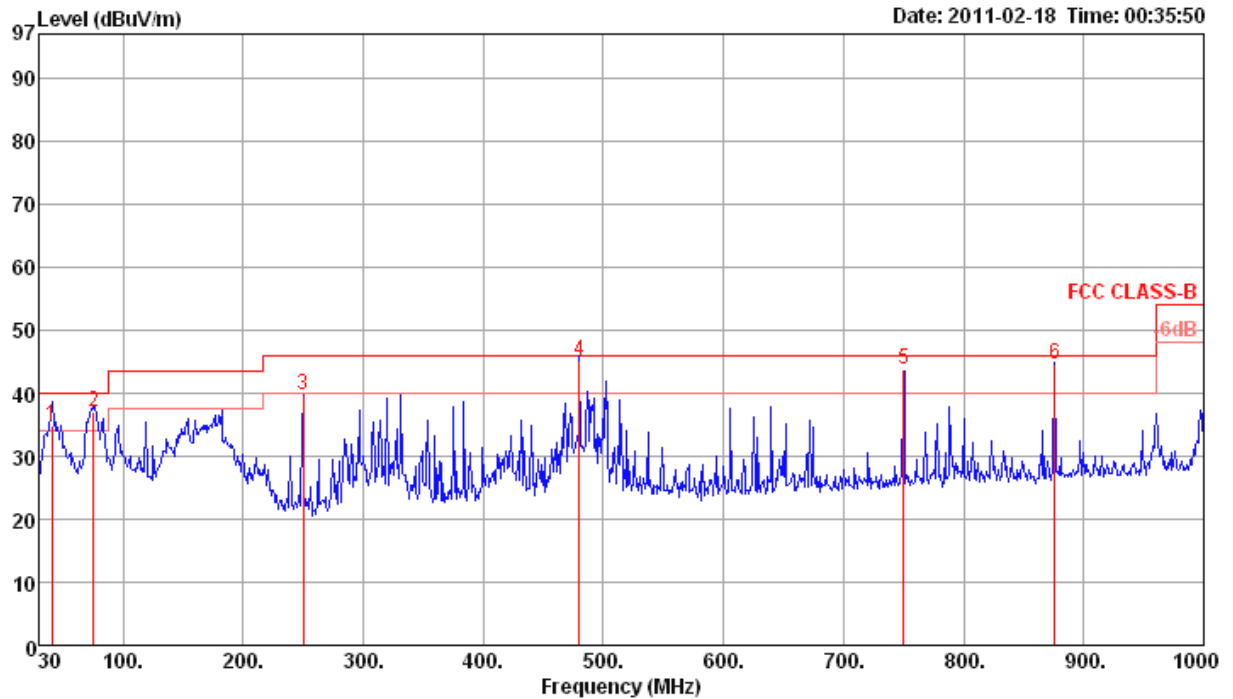

	Freq	Level	Limit	Over	Read	Cable	Preamp	Antenna	T/Pos	A/Pos	Remark	Pol/Phase
	MHz	dBuV/m	dBuV/m	dB	dBuV	dB	dB	dB/m	deg	cm		
1	40.97	34.98	40.00	-5.02	49.53	0.70	27.80	12.55	293	100	QP	VERTICAL
2	75.59	36.95	40.00	-3.05	56.79	0.93	27.70	6.93	0	400	Peak	VERTICAL
3	250.19	39.73	46.00	-6.27	52.06	1.90	27.00	12.77	0	400	Peak	VERTICAL
4	480.00	45.23	46.00	-0.77	53.26	2.66	28.00	17.31	104	116	QP	VERTICAL
5	749.99	43.71	46.00	-2.29	48.58	3.50	27.80	19.43	187	140	QP	VERTICAL
6	875.99	44.61	46.00	-1.39	48.21	3.50	27.45	20.35	98	144	QP	VERTICAL

Note:

The amplitude of spurious emissions that are attenuated by more than 20dB below the permissible value has no need to be reported.

Emission level (dBuV/m) = 20 log Emission level (uV/m).

Corrected Reading: Antenna Factor + Cable Loss + Read Level - Preamp Factor = Level.

4.6.9. Results for Radiated Emissions (1GHz~40GHz)

Temperature	21°C	Humidity	57%
Test Engineer	Serway Li	Configurations	IEEE 802.11n MCS0 20MHz Ch 36 / Ant. 1 + Ant. 2
Test Date	Jan. 12, 2011		

Horizontal

	Freq	Level	Limit Line	Over Limit	Read Level	Cable Loss	Antenna Factor	Preamp Factor	T/Pos	A/Pos	Remark	Pol/Phase
	MHz	dBuV/m	dBuV/m	dB	dBuV	dB	dB/m	dB	deg	cm		
1	15539.61	43.62	60.00	-16.38	35.15	6.13	37.65	35.31	296	100	Average	HORIZONTAL
2	15539.85	61.47	80.00	-18.53	53.00	6.13	37.65	35.31	296	100	Peak	HORIZONTAL

Vertical

	Freq	Level	Limit Line	Over Limit	Read Level	Cable Loss	Antenna Factor	Preamp Factor	T/Pos	A/Pos	Remark	Pol/Phase
	MHz	dBuV/m	dBuV/m	dB	dBuV	dB	dB/m	dB	deg	cm		
1	15535.79	42.57	60.00	-17.43	34.00	6.13	37.73	35.29	308	100	Average	VERTICAL
2	15535.79	59.21	80.00	-20.79	50.64	6.13	37.73	35.29	308	100	Peak	VERTICAL



Temperature	21°C	Humidity	57%
Test Engineer	Serway Li	Configurations	IEEE 802.11n MCS0 20MHz Ch 40 / Ant. 1 + Ant. 2
Test Date	Jan. 18, 2011		

Horizontal

	Freq	Level	Limit	Over	Read	Cable	Antenna	Preamp	T/Pos	A/Pos	Remark	Pol/Phase
	MHz	dBuV/m	dBuV/m	dB	dBuV	Loss	Factor	Factor	deg	cm		
1	15599.84	61.69	80.00	-18.31	53.30	6.13	37.60	35.34	267	100	Peak	HORIZONTAL
2	15599.96	44.80	60.00	-15.20	36.41	6.13	37.60	35.34	267	100	Average	HORIZONTAL

Vertical

	Freq	Level	Limit	Over	Read	Cable	Antenna	Preamp	T/Pos	A/Pos	Remark	Pol/Phase
	MHz	dBuV/m	dBuV/m	dB	dBuV	Loss	Factor	Factor	deg	cm		
1	15600.24	44.17	60.00	-15.83	35.78	6.13	37.60	35.34	302	100	Average	VERTICAL
2	15600.29	59.98	80.00	-20.02	51.59	6.13	37.60	35.34	302	100	Peak	VERTICAL

Temperature	21°C	Humidity	57%
Test Engineer	Serway Li	Configurations	IEEE 802.11n MCS0 20MHz Ch 48 / Ant. 1 + Ant. 2
Test Date	Jan. 18, 2011		

Horizontal

	Freq	Level	Limit Line	Over Limit	Read Level	CableAntenna Loss	Antenna Factor	Preamp Factor	T/Pos	A/Pos	Remark	Pol/Phase
	MHz	dBuV/m	dBuV/m	dB	dBuV	dB	dB/m	dB	deg	cm		
1	15716.90	40.11	60.00	-19.89	31.88	6.14	37.48	35.39	226	100	Average	HORIZONTAL
2	15717.10	55.14	80.00	-24.86	46.91	6.14	37.48	35.39	226	100	Peak	HORIZONTAL

Vertical

	Freq	Level	Limit Line	Over Limit	Read Level	CableAntenna Loss	Antenna Factor	Preamp Factor	T/Pos	A/Pos	Remark	Pol/Phase
	MHz	dBuV/m	dBuV/m	dB	dBuV	dB	dB/m	dB	deg	cm		
1	15716.50	38.83	60.00	-21.17	30.60	6.14	37.48	35.39	265	100	Average	VERTICAL
2	15716.56	52.64	80.00	-27.36	44.41	6.14	37.48	35.39	265	100	Peak	VERTICAL



Temperature	21°C	Humidity	57%
Test Engineer	Serway Li	Configurations	IEEE 802.11n MCS0 40MHz Ch 38 / Ant. 1 + Ant. 2
Test Date	Jan. 12, 2011		

Horizontal

	Freq	Level	Limit Line	Over Limit	Read Level	Cable Loss	Antenna Factor	Preamp Factor	T/Pos	A/Pos	Remark	Pol/Phase
	MHz	dBuV/m	dBuV/m	dB	dBuV	dB	dB/m	dB	deg	cm		
1	15572.30	39.85	60.00	-20.15	31.44	6.13	37.61	35.33	286	100	Average	HORIZONTAL
2	15572.80	51.52	80.00	-28.48	43.11	6.13	37.61	35.33	286	100	Peak	HORIZONTAL

Vertical

	Freq	Level	Limit Line	Over Limit	Read Level	Cable Loss	Antenna Factor	Preamp Factor	T/Pos	A/Pos	Remark	Pol/Phase
	MHz	dBuV/m	dBuV/m	dB	dBuV	dB	dB/m	dB	deg	cm		
1	15564.70	51.06	80.00	-28.94	42.61	6.13	37.65	35.33	150	100	Peak	VERTICAL
2	15584.00	39.37	60.00	-20.63	30.96	6.13	37.61	35.33	150	100	Average	VERTICAL

Temperature	21°C	Humidity	57%
Test Engineer	Serway Li	Configurations	IEEE 802.11n MCS0 40MHz Ch 46 / Ant. 1 + Ant. 2
Test Date	Jan. 18, 2011		

Horizontal

	Freq	Level	Limit	Over	Read	Cable	Antenna	Preamp	T/Pos	A/Pos	Remark	Pol/Phase
	MHz	dBuV/m	dBuV/m	dB	dBuV	Loss	Factor	Factor	deg	cm		
1	15689.95	42.69	60.00	-17.31	34.41	6.14	37.51	35.37	267	100	Average	HORIZONTAL
2	15690.10	53.89	80.00	-26.11	45.61	6.14	37.51	35.37	267	100	Peak	HORIZONTAL

Vertical

	Freq	Level	Limit	Over	Read	Cable	Antenna	Preamp	T/Pos	A/Pos	Remark	Pol/Phase
	MHz	dBuV/m	dBuV/m	dB	dBuV	Loss	Factor	Factor	deg	cm		
1	15689.82	54.08	80.00	-25.92	45.80	6.14	37.51	35.37	320	100	Peak	VERTICAL
2	15689.96	41.41	60.00	-18.59	33.13	6.14	37.51	35.37	320	100	Average	VERTICAL

Note:

The amplitude of spurious emissions that are attenuated by more than 20dB below the permissible value has no need to be reported.

Emission level (dBuV/m) = 20 log Emission level (uV/m).

Corrected Reading: Antenna Factor + Cable Loss + Read Level - Preamp Factor = Level.

The limits above 5GHz shall be extrapolated to the specified distance using an extrapolation factor of 20 dB/decade form 3m to 1.5m.

Distance extrapolation factor = 20 log (specific distance [3m] / test distance [1.5m]) (dB);

Limit line = specific limits (dBuV) + distance extrapolation factor [6 dB].



Temperature	21°C	Humidity	57%
Test Engineer	Serway Li	Configurations	IEEE 802.11a Ch 36 / Ant. 1 + Ant. 2
Test Date	Jan. 12, 2011		

Horizontal

	Freq	Level	Limit Line	Over Limit	Read Level	Cable Loss	Antenna Factor	Preamp Factor	T/Pos	A/Pos	Remark	Pol/Phase
	MHz	dBuV/m	dBuV/m	dB	dBuV	dB	dB/m	dB	deg	cm		
1	15539.80	60.39	80.00	-19.61	51.92	6.13	37.65	35.31	292	100	Peak	HORIZONTAL
2	15540.00	48.58	60.00	-11.42	40.11	6.13	37.65	35.31	292	100	Average	HORIZONTAL

Vertical

	Freq	Level	Limit Line	Over Limit	Read Level	Cable Loss	Antenna Factor	Preamp Factor	T/Pos	A/Pos	Remark	Pol/Phase
	MHz	dBuV/m	dBuV/m	dB	dBuV	dB	dB/m	dB	deg	cm		
1	15536.58	44.24	60.00	-15.76	35.67	6.13	37.73	35.29	304	100	Average	VERTICAL
2	15536.69	59.82	80.00	-20.18	51.25	6.13	37.73	35.29	304	100	Peak	VERTICAL



Temperature	21°C	Humidity	57%
Test Engineer	Serway Li	Configurations	IEEE 802.11a Ch 40 / Ant. 1 + Ant. 2
Test Date	Jan. 18, 2011		

Horizontal

	Freq	Level	Limit	Over	Read	CableAntenna	Preamp	T/Pos	A/Pos	Remark	Pol/Phase
	MHz	dBuV/m	dBuV/m	dB	dBuV	dB	dB/m	deg	cm		
1	15599.67	44.97	60.00	-15.03	36.58	6.13	37.60	35.34	272	100 Average	HORIZONTAL
2	15600.06	63.16	80.00	-16.84	54.77	6.13	37.60	35.34	272	100 Peak	HORIZONTAL

Vertical

	Freq	Level	Limit	Over	Read	CableAntenna	Preamp	T/Pos	A/Pos	Remark	Pol/Phase
	MHz	dBuV/m	dBuV/m	dB	dBuV	dB	dB/m	deg	cm		
1	15600.60	57.98	80.00	-22.02	49.59	6.13	37.60	35.34	239	100 Peak	VERTICAL
2	15600.93	42.99	60.00	-17.01	34.60	6.13	37.60	35.34	239	100 Average	VERTICAL

Temperature	21°C	Humidity	57%
Test Engineer	Serway Li	Configurations	IEEE 802.11a Ch 48 / Ant. 1 + Ant. 2
Test Date	Jan. 18, 2011		

Horizontal

	Freq	Level	Limit Line	Over Limit	Read Level	Cable Loss	Antenna Factor	Preamp Factor	T/Pos	A/Pos	Remark	Pol/Phase
	MHz	dBuV/m	dBuV/m	dB	dBuV	dB	dB/m	dB	deg	cm		
1	15722.16	41.60	60.00	-18.40	33.37	6.14	37.48	35.39	228	100	Average	HORIZONTAL
2	15722.84	58.69	80.00	-21.31	50.46	6.14	37.48	35.39	228	100	Peak	HORIZONTAL

Vertical

	Freq	Level	Limit Line	Over Limit	Read Level	Cable Loss	Antenna Factor	Preamp Factor	T/Pos	A/Pos	Remark	Pol/Phase
	MHz	dBuV/m	dBuV/m	dB	dBuV	dB	dB/m	dB	deg	cm		
1	15719.50	38.43	60.00	-21.57	30.20	6.14	37.48	35.39	304	100	Average	VERTICAL
2	15719.60	53.66	80.00	-26.34	45.43	6.14	37.48	35.39	304	100	Peak	VERTICAL

Note:

The amplitude of spurious emissions that are attenuated by more than 20dB below the permissible value has no need to be reported.

Emission level (dBuV/m) = 20 log Emission level (uV/m).

Corrected Reading: Antenna Factor + Cable Loss + Read Level - Preamp Factor = Level.

The limits above 5GHz shall be extrapolated to the specified distance using an extrapolation factor of 20 dB/decade form 3m to 1.5m.

Distance extrapolation factor = 20 log (specific distance [3m] / test distance [1.5m]) (dB);

Limit line = specific limits (dBuV) + distance extrapolation factor [6 dB].

4.7. Band Edge Emissions Measurement

4.7.1. Limit

For transmitters operating in the 5.15-5.25 GHz band: all emissions outside of the 5.15-5.25 GHz band shall not exceed an EIRP of -27 dBm/MHz (68.3dBuV/m at 3m). For transmitters operating in the 5.470-5.725 GHz band: all emissions outside of the 5.470-5.725 GHz band shall not exceed an EIRP of -27 dBm/MHz (68.3dBuV/m at 3m). For transmitters operating in the 5.725-5.825 GHz band: all emissions within the frequency range from the band edge to 10 MHz above or below the band edge shall not exceed an EIRP of -17 dBm/MHz (78.3dBuV/m at 3m); for frequencies 10 MHz or greater above or below the band edge, emissions shall not exceed an EIRP of -27 dBm/MHz (68.3dBuV/m at 3m). In addition, in case the emission falls within the restricted band specified on 15.205(a), then the 15.209(a) limit in the table below has to be followed.

Frequencies (MHz)	Field Strength (micovolts/meter)	Measurement Distance (meters)
0.009~0.490	2400/F(KHz)	300
0.490~1.705	24000/F(KHz)	30
1.705~30.0	30	30
30~88	100	3
88~216	150	3
216~960	200	3
Above 960	500	3

4.7.2. Measuring Instruments and Setting

Please refer to section 5 of equipments list in this report. The following table is the setting of the spectrum analyzer.

Spectrum Parameter	Setting
Attenuation	Auto
Span Frequency	100 MHz
RB / VB (Emission in restricted band)	1MHz / 1MHz for Peak, 1 MHz / 10Hz for Average
RB / VB (Emission in non-restricted band)	1 MHz / 1 MHz for Peak

4.7.3. Test Procedures

1. The test procedure is the same as section 4.6.3, only the frequency range investigated is limited to 100MHz around bandedges.
2. In case the emission is fail due to the used RB/VB is too wide, marker-delta method of FCC Public Notice DA00-705 will be followed.

4.7.4. Test Setup Layout

This test setup layout is the same as that shown in section 4.6.4.

4.7.5. Test Deviation

There is no deviation with the original standard.

4.7.6. EUT Operation during Test

The EUT was programmed to be in continuously transmitting mode.

4.7.7. Test Result of Band Edge and Fundamental Emissions

Temperature	21°C	Humidity	57%
Test Engineer	Serway Li	Configurations	IEEE 802.11n MCS0 20MHz Ch 36 / Ant. 1 + Ant. 2
Test Date	Jan. 12, 2011		

Channel 36

	Freq	Level	Limit Line	Over Limit	Read Level	Cable Loss	Antenna Factor	Preamp Factor	T/Pos	A/Pos	Remark	Pol/Phase
	MHz	dBuV/m	dBuV/m	dB	dBuV	dB	dB/m	dB	deg	cm		
1	5146.20	79.46	80.00	-0.54	42.36	3.43	33.67	0.00	236	117	Peak	HORIZONTAL
2	5149.40	58.49	60.00	-1.51	21.39	3.43	33.67	0.00	236	117	Average	HORIZONTAL
3	5179.60	96.87	74.00			3.44	33.73	0.00	236	117	Average	HORIZONTAL
4	5181.60	114.93	94.00			3.44	33.73	0.00	236	117	Peak	HORIZONTAL

Item 3, 4 are the fundamental frequency at 5180 MHz.

Temperature	21°C	Humidity	57%
Test Engineer	Serway Li	Configurations	IEEE 802.11n MCS0 20MHz Ch 40 / Ant. 1 + Ant. 2
Test Date	Jan. 18, 2011		

Channel 40

	Freq	Level	Limit Line	Over Limit	Read Level	Cable Loss	Antenna Factor	Preamp Factor	T/Pos	A/Pos	Remark	Pol/Phase
	MHz	dBuV/m	dBuV/m	dB	dBuV	dB	dB/m	dB	deg	cm		
1	5147.60	65.79	80.00	-14.21	28.69	3.43	33.67	0.00	286	115	Peak	HORIZONTAL
2	5150.00	52.45	60.00	-7.55	15.35	3.43	33.67	0.00	286	115	Average	HORIZONTAL
3	5200.40	96.92	74.00			3.45	33.76	0.00	286	115	Average	HORIZONTAL
4	5200.80	115.99	94.00			3.45	33.76	0.00	286	115	Peak	HORIZONTAL

Item 3, 4 are the fundamental frequency at 5200 MHz.

Temperature	21°C	Humidity	57%
Test Engineer	Serway Li	Configurations	IEEE 802.11n MCS0 40MHz Ch 38 / Ant. 1 + Ant. 2
Test Date	Jan. 12, 2011		

Channel 38

	Freq	Level	Limit Line	Over Limit	Read Level	Cable Loss	Antenna Factor	Preamp Factor	T/Pos	A/Pos	Remark	Pol/Phase
	MHz	dBuV/m	dBuV/m	dB	dBuV	dB	dB/m	dB	deg	cm		
1	5146.80	76.85	80.00	-3.15	39.75	3.43	33.67	0.00	228	111	Peak	HORIZONTAL
2	5148.80	57.99	60.00	-2.01	20.89	3.43	33.67	0.00	228	111	Average	HORIZONTAL
3	5191.20	109.21	94.00			3.44	33.73	0.00	228	111	Peak	HORIZONTAL
4	5191.60	85.90	74.00			3.44	33.73	0.00	228	111	Average	HORIZONTAL

Item 3, 4 are the fundamental frequency at 5190 MHz.

Temperature	21°C	Humidity	57%
Test Engineer	Serway Li	Configurations	IEEE 802.11n MCS0 40MHz Ch 46 / Ant. 1 + Ant. 2
Test Date	Jan. 18, 2011		

Channel 46

	Freq	Level	Limit Line	Over Limit	Read Level	Cable Loss	Antenna Factor	Preamp Factor	T/Pos	A/Pos	Remark	Pol/Phase
	MHz	dBuV/m	dBuV/m	dB	dBuV	dB	dB/m	dB	deg	cm		
1	5148.00	70.67	80.00	-9.33	33.57	3.43	33.67	0.00	283	116	Peak	HORIZONTAL
2	5150.00	53.77	60.00	-6.23	16.67	3.43	33.67	0.00	283	116	Average	HORIZONTAL
3	5228.00	88.61	74.00			3.46	33.79	0.00	283	116	Average	HORIZONTAL
4	5233.20	112.67	94.00			3.46	33.82	0.00	283	116	Peak	HORIZONTAL

Item 3, 4 are the fundamental frequency at 5230 MHz.

Note:

Emission level (dBuV/m) = 20 log Emission level (uV/m)

Corrected Reading: Antenna Factor + Cable Loss + Read Level - Preamp Factor = Level

The limits above 5GHz shall be extrapolated to the specified distance using an extrapolation factor of 20 dB/decade from 3m to 1.5m.

Distance extrapolation factor = 20 log (specific distance [3m] / test distance [1.5m]) (dB);

Limit line = specific limits (dBuV) + distance extrapolation factor [6 dB].

Temperature	21°C	Humidity	57%
Test Engineer	Serway Li	Configurations	IEEE 802.11a Ch 36 / Ant. 1+2
Test Date	Jan. 12, 2011		

Channel 36

	Freq	Level	Limit Line	Over Limit	Read Level	Cable Loss	Antenna Factor	Preamp Factor	T/Pos	A/Pos	Remark	Pol/Phase
	MHz	dBuV/m	dBuV/m	dB	dBuV	dB	dB/m	dB	deg	cm		
1	5146.20	79.66	80.00	-0.34	42.56	3.43	33.67	0.00	278	118	Peak	HORIZONTAL
2	5150.00	57.25	60.00	-2.75	20.15	3.43	33.67	0.00	278	118	Average	HORIZONTAL
3	5181.00	96.81	74.00			3.44	33.73	0.00	278	118	Average	HORIZONTAL
4	5181.40	115.18	94.00			3.44	33.73	0.00	278	118	Peak	HORIZONTAL

Item 3, 4 are the fundamental frequency at 5180 MHz.

Temperature	21°C	Humidity	57%
Test Engineer	Serway Li	Configurations	IEEE 802.11a Ch 40 / Ant. 1+2
Test Date	Jan. 18, 2011		

Channel 40

	Freq	Level	Limit Line	Over Limit	Read Level	Cable Loss	Antenna Factor	Preamp Factor	T/Pos	A/Pos	Remark	Pol/Phase
	MHz	dBuV/m	dBuV/m	dB	dBuV	dB	dB/m	dB	deg	cm		
1	5150.00	52.28	60.00	-7.72	15.18	3.43	33.67	0.00	244	126	Average	HORIZONTAL
2	5150.00	64.53	80.00	-15.47	27.43	3.43	33.67	0.00	244	126	Peak	HORIZONTAL
3	5199.20	98.23	74.00			3.45	33.76	0.00	244	126	Average	HORIZONTAL
4	5199.20	116.20	94.00			3.45	33.76	0.00	244	126	Peak	HORIZONTAL

Item 3, 4 are the fundamental frequency at 5200 MHz.

Note:

Emission level (dBuV/m) = 20 log Emission level (uV/m)

Corrected Reading: Antenna Factor + Cable Loss + Read Level - Preamp Factor = Level

The limits above 5GHz shall be extrapolated to the specified distance using an extrapolation factor of 20 dB/decade from 3m to 1.5m.

Distance extrapolation factor = 20 log (specific distance [3m] / test distance [1.5m]) (dB);

Limit line = specific limits (dBuV) + distance extrapolation factor [6 dB].

4.8. Frequency Stability Measurement

4.8.1. Limit

Manufacturers of U-NII devices are responsible for ensuring frequency stability such that an emissions is maintained within the band of operation under all conditions of normal operation as specified in the user's manual or $\pm 20\text{ppm}$ (IEEE 802.11 specification).

4.8.2. Measuring Instruments and Setting

Please refer to section 5 of equipments list in this report. The following table is the setting of the spectrum analyzer.

Spectrum Parameter	Setting
Attenuation	Auto
Span Frequency	Entire absence of modulation emissions bandwidth
RB	10 kHz
VB	10 kHz
Sweep Time	Auto

4.8.3. Test Procedures

1. The transmitter output (antenna port) was connected to the spectrum analyzer.
2. EUT have transmitted absence of modulation signal and fixed channelize.
3. Set the spectrum analyzer span to view the entire absence of modulation emissions bandwidth.
4. Set RBW = 10 kHz, VBW = 10 kHz with peak detector and maxhold settings.
5. f_c is declaring of channel frequency. Then the frequency error formula is $(f_c - f) / f_c \times 10^6$ ppm and the limit is less than $\pm 20\text{ppm}$ (IEEE 802.11 specification).
6. The test extreme voltage is to change the primary supply voltage from 85 to 115 percent of the nominal value
7. Extreme temperature rule is $-30^\circ\text{C} \sim 50^\circ\text{C}$.
8. Measuring multiple antennas, the connector is required to link with spectrum analyzer through a combiner.

4.8.4. Test Setup Layout

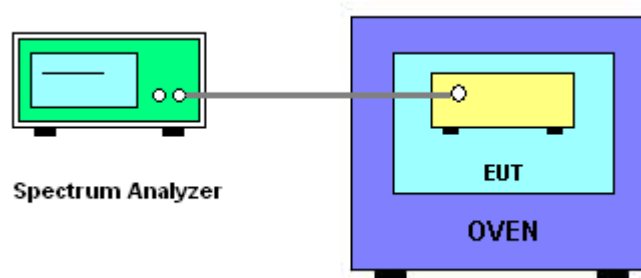

4.8.5. Test Deviation

There is no deviation with the original standard.

4.8.6. EUT Operation during Test

The EUT was programmed to be in continuously un-modulation transmitting mode.

4.8.7. Test Result of Frequency Stability

Voltage vs. Frequency Stability

Voltage	Measurement Frequency (MHz)
(V)	5200
126.50	5199.9886
110.00	5199.9887
93.50	5199.9886
Max. Deviation (MHz)	0.011400
Max. Deviation (ppm)	2.19

Temperature vs. Frequency Stability

Temperature	Measurement Frequency (MHz)
(°C)	5200
-30	5199.9888
-20	5199.9886
-10	5199.9887
0	5199.9885
10	5199.9887
20	5199.9887
30	5199.9888
40	5199.9887
50	5199.9887
Max. Deviation (MHz)	0.011500
Max. Deviation (ppm)	2.21

4.9. Antenna Requirements

4.9.1. Limit

Except for special regulations, the Low-power Radio-frequency Devices must not be equipped with any jacket for installing an antenna with extension cable. An intentional radiator shall be designed to ensure that no antenna other than that furnished by the responsible party shall be used with the device. The use of a permanently attached antenna or of an antenna that uses a unique coupling to the intentional radiator shall be considered sufficient to comply with the provisions of this Section. The manufacturer may design the unit so that the user can replace a broken antenna, but the use of a standard antenna jack or electrical connector is prohibited. Further, this requirement does not apply to intentional radiators that must be professionally installed.

4.9.2. Antenna Connector Construction

Please refer to section 3.3 in this test report; antenna connector complied with the requirements.

5. LIST OF MEASURING EQUIPMENTS

Instrument	Manufacturer	Model No.	Serial No.	Characteristics	Calibration Date	Remark
EMI Test Receiver	R&S	ESCS 30	100377	9kHz ~ 2.75GHz	Sep. 01, 2010	Conduction (CO01-CB)
LISN	F.C.C.	FCC-LISN-50-16-2	04083	150kHz ~ 100MHz	Apr. 24, 2010	Conduction (CO01-CB)
V- LISN	Schwarzbeck	NSLK 8127	8127-478	9K ~ 30MHz	Oct. 30, 2010	Conduction (CO01-CB)
PULSE LIMITER	R&S	ESH3-Z2	100430	9K~30MHz	Jan. 04, 2011	Conduction (CO01-CB)
COND Cable	-	Cable	-	0.15MHz~30MHz	Dec. 01, 2010	Conduction (CO01-CB)
BILOG ANTENNA	Schaffner	CBL6112D	22021	20MHz ~ 2GHz	Oct. 17, 2010	Radiation (03CH01-CB)
Horn Antenna	EMCO	3115	00075790	750MHz~18GHz	Nov. 13, 2010	Radiation (03CH01-CB)
Horn Antenna	SCHWARZBEAK	BBHA 9170	BBHA9170252	15GHz ~ 40GHz	Oct. 08, 2010	Radiation (03CH01-CB)
Pre-Amplifier	Agilent	8447D	2944A10991	0.1MHz ~ 1.3GHz	Nov. 17, 2010	Radiation (03CH01-CB)
Pre-Amplifier	Agilent	8449B	3008A02310	1GHz ~ 26.5GHz	Nov. 06, 2010	Radiation (03CH01-CB)
Pre-Amplifier	WM	TF-130N-R1	923365	26.5GHz ~ 40GHz	Nov. 17, 2010	Radiation (03CH01-CB)
Spectrum analyzer	R&S	FSP	100304	9kHz ~ 40GHz	Nov. 06, 2010	Radiation (03CH01-CB)
EMI Test Receiver	R&S	ESCS 30	100355	9KHz ~ 2.75GHz	Mar. 06, 2010	Radiation (03CH01-CB)
Loop Antenna	R&S	HFH2-Z2	860004/001	9 kHz - 30 MHz	Sep. 09, 2010*	Radiation (03CH01-CB)
Turn Table	INN CO	CO 2000	N/A	0 ~ 360 degree	N/A	Radiation (03CH01-CB)
Antenna Mast	INN CO	CO2000	N/A	1 m - 4 m	N/A	Radiation (03CH01-CB)
RF Cable-low	Woken	Low Cable-1	-	30 MHz - 1 GHz	Nov. 17, 2010	Radiation (03CH01-CB)
RF Cable-high	Woken	High Cable-1	-	1 GHz – 26.5 GHz	Nov. 17, 2010	Radiation (03CH01-CB)
RF Cable-high	Woken	High Cable-2	-	1 GHz – 26.5 GHz	Nov. 17, 2010	Radiation (03CH01-CB)
RF Cable-high	Woken	High Cable-3	-	1 GHz - 40 GHz	Nov. 17, 2010	Radiation (03CH01-CB)
RF Cable-high	Woken	High Cable-4	-	1 GHz - 40 GHz	Nov. 17, 2010	Radiation (03CH01-CB)
Spectrum analyzer	R&S	FSP30	100023	9KHz~30GHz	Mar. 05, 2010	Conducted (TH01-CB)
Temp. and Humidity Chamber	TEN BILLION	TTH-D3SP	TBN-931011	-30~100°C	May. 21, 2010	Conducted (TH01-CB)
Signal Generator	R&S	SMR40	100302	10MHz-40GHz	Mar. 09, 2010	Conducted (TH01-CB)
RF Power Divider	HP	11636A	00306	2GHz ~ 18GHz	N/A	Conducted (TH01-CB)
RF Power Splitter	Anaren	44100	1839	2GHz ~ 18GHz	N/A	Conducted (TH01-CB)

Instrument	Manufacturer	Model No.	Serial No.	Characteristics	Calibration Date	Remark
RF Power Splitter	Anaren	42100	17930	2GHz ~ 18GHz	N/A	Conducted (TH01-CB)
Signal generator	R&S	SMU200A	102782	10MHz-40GHz	Mar. 09, 2010	Conducted (TH01-CB)
Horn Antenna	COM-POWER	AH-118	071187	1GHz – 18GHz	Apr. 16, 2010	Conducted (TH01-CB)
Horn Antenna	COM-POWER	AH-118	071042	1GHz – 18GHz	Oct. 14, 2010	Conducted (TH01-CB)
RF Cable-high	Woken	High Cable-7	-	1 GHz – 26.5 GHz	Nov. 17, 2010	Conducted (TH01-CB)
RF Cable-high	Woken	High Cable-8	-	1 GHz – 26.5 GHz	Nov. 17, 2010	Conducted (TH01-CB)
RF Cable-high	Woken	High Cable-9	-	1 GHz – 26.5 GHz	Nov. 17, 2010	Conducted (TH01-CB)
RF Cable-high	Woken	High Cable-10	-	1 GHz – 26.5 GHz	Nov. 17, 2010	Conducted (TH01-CB)
RF Cable-high	Woken	High Cable-11	-	1 GHz – 26.5 GHz	Nov. 17, 2010	Conducted (TH01-CB)
RF Cable-high	Woken	High Cable-12	-	1 GHz – 26.5 GHz	Nov. 17, 2010	Conducted (TH01-CB)
RF Cable-high	Woken	High Cable-13	-	1 GHz – 26.5 GHz	Nov. 17, 2010	Conducted (TH01-CB)
Power Sensor	Anritsu	MA2411B	0917223	300MHz~40GHz	Sep. 13, 2010	Conducted (TH01-CB)
Power Meter	Anritsu	ML2495A	1035008	300MHz~40GHz	Sep. 08, 2010	Conducted (TH01-CB)

Note: Calibration Interval of instruments listed above is one year.

* Calibration Interval of instruments listed above is two year.

NCR means Non-Calibration required.

6. TEST LOCATION

SHIJR	ADD : 6Fl., No. 106, Sec. 1, Shintai 5th Rd., Shijr City, Taipei, Taiwan 221, R.O.C. TEL : 886-2-2696-2468 FAX : 886-2-2696-2255
HWA YA	ADD : No. 52, Hwa Ya 1st Rd., Kwei-Shan Hsiang, Tao Yuan Hsien, Taiwan, R.O.C. TEL : 886-3-327-3456 FAX : 886-3-318-0055
LINKOU	ADD : No. 30-2, Dingfu Tsuen, Linkou Shiang, Taipei, Taiwan 244, R.O.C TEL : 886-2-2601-1640 FAX : 886-2-2601-1695
DUNGHU	ADD : No. 3, Lane 238, Kangle St., Neihu Chiu, Taipei, Taiwan 114, R.O.C. TEL : 886-2-2631-4739 FAX : 886-2-2631-9740
JUNGHE	ADD : 7Fl., No. 758, Jungjeng Rd., Junghe City, Taipei, Taiwan 235, R.O.C. TEL : 886-2-8227-2020 FAX : 886-2-8227-2626
NEIHU	ADD : 4Fl., No. 339, Hsin Hu 2 nd Rd., Taipei 114, Taiwan, R.O.C. TEL : 886-2-2794-8886 FAX : 886-2-2794-9777
JHUBEI	ADD : No.8, Lane 724, Bo-ai St., Jhubei City, HsinChu County 302, Taiwan, R.O.C. TEL : 886-3-656-9065 FAX : 886-3-656-9085

7. TAF CERTIFICATE OF ACCREDITATION



Certificate No. : L1190-091230

財團法人全國認證基金會
Taiwan Accreditation Foundation

Certificate of Accreditation

This is to certify that

Sporton International Inc.
EMC & Wireless Communications Laboratory
No.52, Hwa Ya 1st Rd., Hwa Ya Technology Park, Kwei-Shan Hsiang, Tao Yuan Hsien,
Taiwan, R.O.C.

is accredited in respect of laboratory

Accreditation Criteria	: ISO/IEC 17025:2005
Accreditation Number	: 1190
Originally Accredited	: December 15, 2003
Effective Period	: January 10, 2010 to January 09, 2013
Accredited Scope	: Testing Field, see described in the Appendix
Specific Accreditation Program	: Accreditation Program for Designated Testing Laboratory for Commodities Inspection Accreditation Program for Telecommunication Equipment Testing Laboratory Accreditation Program for BSMI Mutual Recognition Arrangement with Foreign Authorities

Jay-san Chen

Jay-San Chen
President, Taiwan Accreditation Foundation
Date : December 30, 2009

Pl, total 22 pages

The Appendix forms an integral part of this Certificate, which shall be invalid when use without the Appendix