



# FCC TEST REPORT

According to

## FCC Rules and Regulations Part 15 Subpart C

Applicant	: Netgear Inc.
Address	: 350 East Plumeria Drive, San Jose, CA 95134, U.S.A.
Equipment	: RANGEMAX WIRELESS-N DSL GIGABIT MODEM ROUTER
Model No.	: DGN3500; DGN3500B
FCC ID	: PY309200109
Trade Name	: NETGEAR

### Laboratory Accreditation



- The test result refers exclusively to the test presented test model / sample.,
- Without written approval of **CerpPASS Technology Corp.** the test report shall not be reproduced except in full.
- The EUT is also considered as a kind of computer peripheral, because the connection to computer is necessary for typical use. It has been verified to comply with the requirements of FCC Part 15, Subpart B, Class B (DoC). The test report has been issued separately.



## Contents

<b>1. Report of Measurements and Examinations</b> .....	<b>5</b>
1.1 List of Measurements and Examinations .....	5
<b>2. Test Configuration of Equipment under Test</b> .....	<b>6</b>
2.1 Feature of Equipment under Test.....	6
2.2 Carrier Frequency of Channels .....	7
2.3 Test Mode and Test Software .....	7
2.4 Description of Test System.....	8
2.5 Connection Diagram of Test System.....	9
2.6 General Information of Test.....	10
2.7 Measurement Uncertainty .....	10
2.8 History of this test report .....	11
<b>3. Antenna Requirements</b> .....	<b>12</b>
3.1 Standard Applicable .....	12
3.2 Antenna Construction and Directional Gain.....	12
<b>4. Test of Conducted Emission</b> .....	<b>13</b>
4.1 Test Limit .....	13
4.2 Test Procedures .....	13
4.3 Typical Test Setup .....	14
4.4 Measurement equipment .....	14
4.5 Test Result and Data .....	15
4.6 Test Photographs .....	27
<b>5. Test of Radiated Emission</b> .....	<b>28</b>
5.1 Test Limit .....	28
5.2 Test Procedures .....	28
5.3 Typical Test Setup .....	29
5.4 Measurement equipment .....	29
5.5 Test Result and Data .....	30
5.6 Test Photographs .....	102
<b>6. 6dB Bandwidth Measurement Data</b> .....	<b>103</b>
6.1 Test Limit .....	103
6.2 Test Procedures .....	103
6.3 Test Setup Layout .....	103
6.4 Measurement equipment .....	103
6.5 Test Result and Data.....	103
<b>7. Maximum Peak Output Power</b> .....	<b>116</b>
7.1 Test Limit .....	116
7.2 Test Procedures .....	116
7.3 Test Setup Layout .....	116
7.4 Measurement equipment .....	116
7.5 Test Result and Data.....	116
<b>8. Band Edges Measurement</b> .....	<b>129</b>
8.1 Test Limit .....	129
8.2 Test Procedure .....	129



8.3 Test Setup Layout ..... 129

8.4 Measurement equipment ..... 129

8.5 Test Result and Data ..... 129

8.6 Restrict Band Emission Measurement Data ..... 146

**9. Power Spectral Density ..... 150**

9.1 Test Limit ..... 150

9.2 Test Procedures ..... 150

9.3 Test Setup Layout ..... 150

9.4 Measurement equipment ..... 150

9.5 Test Result and Data ..... 151

**10. Restricted Bands of Operation ..... 164**

10.1 Labeling Requirement ..... 164

**Appendix A. Photographs of EUT.....A1 ~ A13**



# CERTIFICATE OF COMPLIANCE

According to

## FCC Rules and Regulations Part 15 Subpart C

Applicant : Netgear Inc.  
Address : 350 East Plumeria Drive, San Jose,  
CA 95134, U.S.A.  
Equipment : RANGEMAX WIRELESS-N DSL GIGABIT  
MODEM ROUTER  
Model No. : DGN3500; DGN3500B  
FCC ID : PY309200109

I **HEREBY** CERTIFY THAT :

The measurements shown in this test report were made in accordance with the procedures given in **ANSI C63.4** The equipment was **passed** the test performed according to **FCC Rules and Regulations Part 15 Subpart C (2007)**.

The test was carried out on Jul. 22, 2009 at **Cerpass Technology Corp.**

Signature

Anson Chou

EMC/RF B.U. Vice General Manager



## 1. Report of Measurements and Examinations

### 1.1 List of Measurements and Examinations

FCC Rule	Description of Test	Result
15.203	. Antenna Requirement	Pass
15.207	. Conducted Emission	Pass
15.209 15.247(d)	. Radiated Emission	Pass
15.247(a)(2)	. 6dB Bandwidth	Pass
15.247(b)	. Maximum Peak Output Power	Pass
15.247(d)	. 100kHz Bandwidth of Frequency Band Edges	Pass
15.247(e)	. Power Spectral Density	Pass
1.1307 1.1310 2.1091 2.1093	. RF Exposure Compliance	Pass



## 2. Test Configuration of Equipment under Test

### 2.1 Feature of Equipment under Test

Spreading	:	802.11b: DSSS, CCK(QPSK, BPSK) 802.11g: OFDM(64QAM, 16QAM, QPSK, BPSK) 802.11n: OFDM(64QAM, 16QAM, QPSK, BPSK)
Frequency Range	:	802.11b/g/n:2.4~2.4835GHz
Number of Channels	:	USA, Canada, and Taiwan: 1~11 Japan: 1~14 Most European Countries: 1~13 France: 10~13
Data Rate	:	802.11b: 11, 5.5, 2, 1Mbps 802.11g:54, 48, 36, 24, 18, 12, 9, 6 Mbps 802.11n: HT40 mode: 270/15, 243/14, 216/13, 162/12, 108/11, 81/10, 54/9, 27/8, 135/7, 121.5/6, 108/5, 81/4, 54/3, 40.5/2, 27/1, 13.5/0Mbps HT20 mode: 130/15, 117/14, 104/13, 78/12, 52/11, 39/10, 26/9, 13/8, 65/7, 58.5/6, 52/5, 39/4, 26/3, 19.5/2, 13/1, 6.5/0Mbps
Modulation	:	802.11n: OFDM 802.11g: OFDM 802.11b: CCK, DQPSK, DBPSK
Antenna	:	Ant1: PIFA Antenna/ Gain: 2dBi Ant2: PIFA Antenna/ Gain: 2dBi
Security	:	IEEE802.1x and WPA (available in the future) WEP 64 bit, 128 bit
Transmit Power	:	FCC: 802.11b: 17~18dBm(Average) 802.11g: 54M = 15dBm(Average) 36M~48M = 16dBm(Average) 6M~24M=17dBm~18dBm(Average) 802.11n: HT40 mode: 13.5M, 27M, 40.5M, 54M, 81M, 108M, 162M, 216M = 16~18dBm(Average) 121.5M, 135M, 243M, 270M=13~15dBm(Average) HT20 mode: 6.5M, 13M, 19.5M, 26M, 39M, 52M, 78M, 104M = 16~18dBm 58.5M, 65M, 117M, 130M=13~15dBm(Average) ETSI: 802.11b: 17~18dBm(Average) 802.11g: 48M~54M=13dBm~15dBm(Average) 6M~36M=16dBm~18dBm(Average) 802.11n: HT40 mode: 13.5M, 27M, 40.5M, 54M, 81M, 108M, 162M, 216M=16~18dBm(Average) 121.5M, 135M, 243M, 270M=13~15dBm(Average) HT20 mode: 6.5M, 13M, 19.5M, 26M, 39M, 52M, 78M, 104M= 16~18dBm(Average) 58.5M, 65M, 117M, 130M= 13~15dBm(Average)



## 2.2 Carrier Frequency of Channels

802.11b, 802.11g, 802.11n, HT20

Channel	Frequency(MHz)	Channel	Frequency(MHz)
01	2412	07	2442
02	2417	08	2447
03	2422	09	2452
04	2427	10	2457
05	2432	11	2462
06	2437	12	---

802.11n, HT40

Channel	Frequency(MHz)	Channel	Frequency(MHz)
01	---	07	2442
02	---	08	2447
03	2422	09	2452
04	2427	10	---
05	2432	11	---
06	2437	---	---

## 2.3 Test Mode and Test Software

- a. During testing, the interface cables and equipment positions were varied according to ANSI C63.4.
- b. The complete test system included remote workstation, PC, Monitor, Keyboard, Mouse, Modem, Printer, Flash Memory and EUT for RF test. The remote workstation includes Notebooks and DSLAN.
- c. An executive program, "Ping.exe" under WIN XP, which transmits and receives data to the remote workstation through Wireless.
- d. The following test mode and test software was performed for conduction and radiation test:
  - Test Mode 1: Adapter: FA-1201500SUA
    - 802.11b/g, 802.11n, HT20: CH01: 2412MHz, CH06: 2437MHz, CH11: 2462MHz
    - 802.11n, HT40: CH03: 2422MHz, CH06: 2437MHz, CH09: 2452MHz
  - Test Mode 2: Adapter: AD661F0916BLF
    - 802.11b/g, 802.11n, HT20: CH01: 2412MHz, CH06: 2437MHz, CH11: 2462MHz
    - 802.11n, HT40: CH03: 2422MHz, CH06: 2437MHz, CH09: 2452MHz



## 2.4 Description of Test System

Device	Manufacturer	Model No.	Description
PC	IBM	IGV	Power Cable, Unshielding 1.8 m
Monitor	ViewSonic	G90fB	Power Cable, Adapter Unshielding 1.8 m Data Cable, VGA Shielding 1.35 m
Keyboard	IBM	KB-0225	Data Cable, PS2 Shielding 1.85 m
Mouse	IBM	MU29J	Data Cable, PS2 Shielding 1.85 m
Modem	ACEXX	DM-1414	Power Cable, Adapter Unshielding 1.8 m Data Cable, RS232 Shielding 1.35 m
Printer	HP	Desk Jet 400	Power Cable, Adapter Unshielding 1.8 m Data Cable, Print Shielding 1.6 m
Remote workstation			
Notebook	DELL	PP10L	Power Cable, Adapter Unshielding 1.8 m
Notebook	TOSHIBA	PSA50T-05M00C	Power Cable, Adapter Unshielding 1.8 m
DSLAN	2YXZL	IES-1000	Power Cable, Unshielding 1.8 m

### Use Cable:

Cable	Quantity	Description
RJ45	3	Unshielding, 3.0m
RJ45	1	Unshielding, 1.5m
RJ11	1	Unshielding, 5.0m





## 2.5 Connection Diagram of Test System

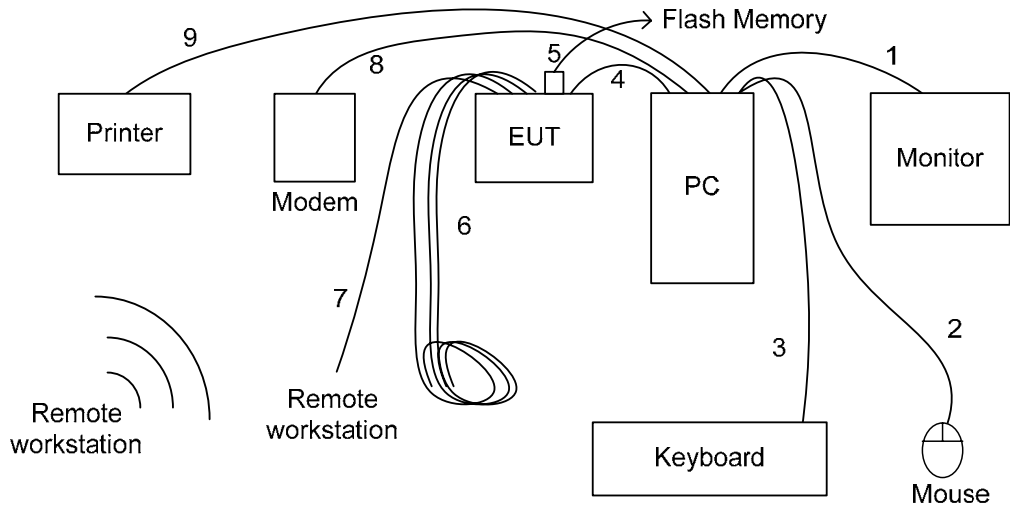

1. The VGA cable is connected from PC to Monitor.
  2. The PS2 cable is connected from PC to the Mouse.
  3. The PS2 cable is connected from PC to the Keyboard.
  4. The RJ45 cable is connected from PC to the EUT.
  5. The Flash Memory is connected to the EUT.
  6. These RJ45 cables (\*3) are floating.
  7. The RJ11 Cable is connected from EUT to the Remote workstation.
  8. The RS232 cable is connected from PC to the Modem.
  9. The Print cable is connected from PC to the Printer.
- \* The EUT keeps to transmit and receive data to remote workstation by Wireless.



## 2.6 General Information of Test

Test Site :	Cerpass Technology Corp. 2F-11, No. 3, Yuan Qu St., (Nankang Software Park), Taipei, Taiwan 115, R.O.C.
Test Site Location (OATS1-SD):	No. 7-2, Moshihkeng, Fongtian Village, Shihding Township, Taipei County, Taiwan, R.O.C.
FCC Registration Number :	TW1049, 982971. 488071
IC Registration Number :	4934C-1
VCCI Registration Number :	T-543 for Telecommunication Test C-3328 for Conducted emission test R-3013 for Radiated emission test
Test Voltage:	AC 120V
Test in Compliance with:	ANSI C63.4-2003 FCC Part 15 Subpart C
Frequency Range Investigated:	Conducted: from 150kHz to 30MHz Radiation: from 30MHz to 24620MHz
Test Distance:	The test distance of radiated emission from antenna to EUT is 3 M.

## 2.7 Measurement Uncertainty

Measurement Item	Measurement Frequency	Polarization	Uncertainty
Conducted Emission	9 kHz ~ 30 MHz	LINE/NEUTRAL	2.71 dB
Radiated Emission	30 MHz ~ 25GHz	Vertical	4.11 dB
		Horizontal	4.10 dB
6 dB Bandwidth	---	---	7500 Hz
Maximum Peak Output Power	---	---	1.4 dB
100kHz Bandwidth of Frequency Band Edges	---	---	2.2 dB
Power Spectral Density	---	---	2.2 dB





### 3. Antenna Requirements

#### 3.1 Standard Applicable

For intentional device, according to FCC 47 CFR Section 15.203, an intentional radiator shall be designed to ensure that no antenna other than that furnished by the responsible party shall be used with the device.

And according to FCC 47 CFR Section 15.247 (b), if transmitting antennas of directional gain greater than 6dBi are used, the power shall be reduced by the amount in dB that the directional gain of the antenna exceeds 6dBi.

#### 3.2 Antenna Construction and Directional Gain

Ant1:

Antenna type: PIFA Antenna

Antenna Gain: 2 dBi

Ant2:

Antenna type: PIFA Antenna

Antenna Gain: 2 dBi



## 4. Test of Conducted Emission

### 4.1 Test Limit

Conducted Emissions were measured from 150 kHz to 30 MHz with a bandwidth of 9 KHz on the 120 VAC power and return leads of the EUT according to the methods defined in ANSI C63.4-2003 Section 3.1. The EUT was placed on a nonmetallic stand in a shielded room 0.8 meters above the ground plane as shown in section 2.2. The interface cables and equipment positioning were varied within limits of reasonable applications to determine the position produced maximum conducted emissions.

Frequency (MHz)	Quasi Peak (dB $\mu$ V)	Average (dB $\mu$ V)
0.15 – 0.5	66-56*	56-46*
0.5 – 5.0	56	46
5.0 – 30.0	60	50

\*Decreases with the logarithm of the frequency.

### 4.2 Test Procedures

- a. The EUT was placed 0.4 meter from the conducting wall of the shielding room was kept at least 80 centimeters from any other grounded conducting surface.
- b. Connect EUT to the power mains through a line impedance stabilization network (LISN).
- c. All the support units are connecting to the other LISN.
- d. The LISN provides 50 ohm coupling impedance for the measuring instrument.
- e. The FCC states that a 50 ohm, 50 micro-Henry LISN should be used.
- f. Both sides of AC line were checked for maximum conducted interference.
- g. The frequency range from 150 kHz to 30 MHz was searched.
- h. Set the test-receiver system to Peak Detect Function and Specified Bandwidth with Maximum Hold Mode.



### 4.3 Typical Test Setup

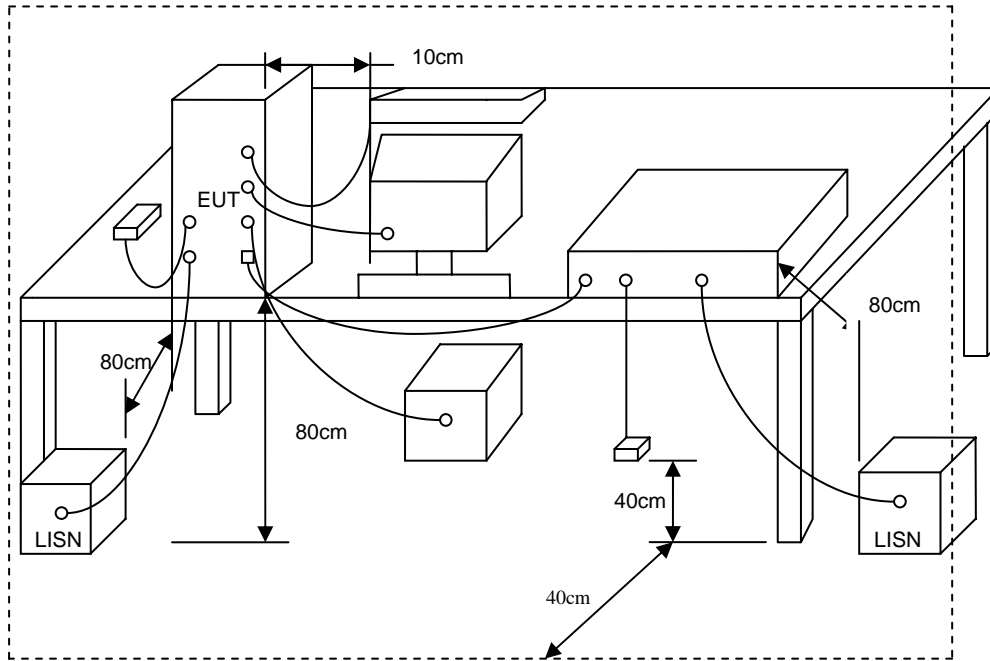

### 4.4 Measurement equipment

Instrument/Ancillary	Manufacturer	Model No.	Serial No.	Calibration Date	Valid Date.
EMI Receiver	R&S	ESCI	100443	2008/09/27	2009/09/26
LISN	NSLK 8127	Schwarzbeck	8127-516	2009/05/15	2010/05/14
LISN	Rolf Heine	NNB-2/16Z	03/10058	2009/04/18	2010/04/17



## 4.5 Test Result and Data

Power	: AC 120V	Pol/Phase	: LINE
Test Mode 1	: 802.11g CH1	Temperature	: 25 °C
Memo	: Adapter: FA-1201500SUA	Humidity	: 65 %

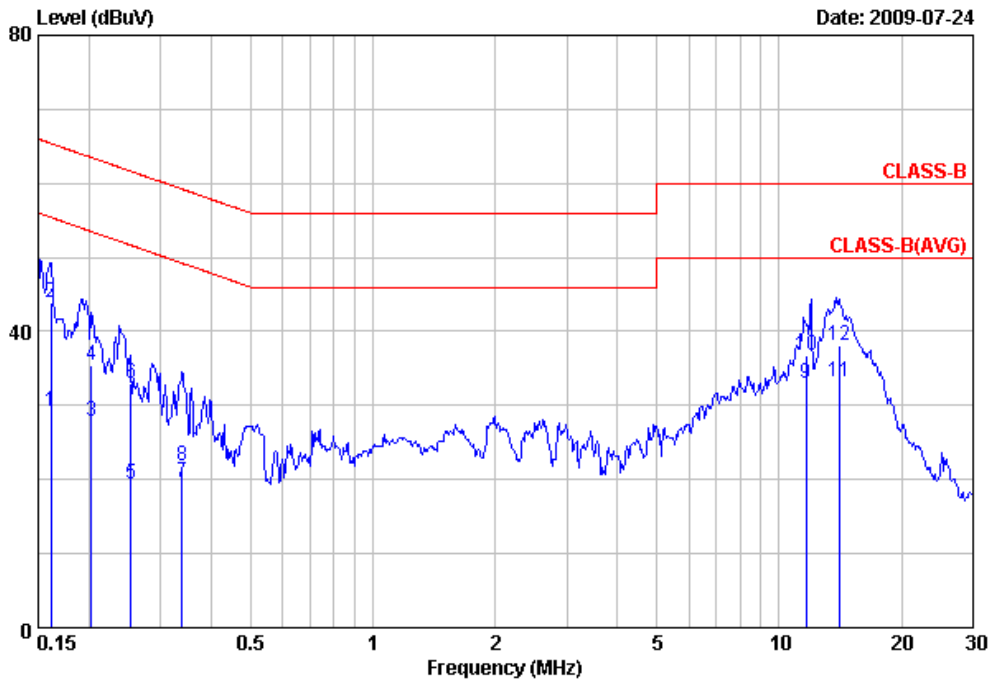

Item	Freq	Read Value	Factor	Result	Limit	Margin	Remark
	MHz	dBuV/m	dB	dBuV/m	dBuV/m	dB	
1	0.16	29.21	0.07	29.28	55.38	-26.10	Average
2	0.16	43.76	0.07	43.83	65.38	-21.55	QP
3	0.20	27.86	0.07	27.93	53.50	-25.57	Average
4	0.20	35.39	0.07	35.46	63.50	-28.04	QP
5	0.25	19.24	0.07	19.31	51.62	-32.31	Average
6	0.25	32.86	0.07	32.93	61.62	-28.69	QP
7	0.34	19.47	0.08	19.55	49.22	-29.67	Average
8	0.34	21.70	0.08	21.78	59.22	-37.44	QP
9	11.63	32.53	0.53	33.06	50.00	-16.94	Average
10	11.63	36.18	0.53	36.71	60.00	-23.29	QP
11	14.06	32.71	0.51	33.22	50.00	-16.78	Average
12	14.06	37.65	0.51	38.16	60.00	-21.84	QP

## Notes:

1. Result = Read Value + Factor
2. Factor = LISN(ISN)Factor + Cable Loss
3. All emission below 1GHz at 802.11b/g mode are all the same,so the 802.11g mode chosen as representative in final test.
4. According to technical experiences,all spurious emission of 802.11g mode at channel 1,6,11 are almost the same below 1GHz,so that the channel 1 was chosen as representative in final test.
5. The data is worse case.



Power	: AC 120V	Pol/Phase	: NEUTRAL
Test Mode 1	: 802.11g CH1	Temperature	: 25 °C
Memo	: Adapter: FA-1201500SUA	Humidity	: 65 %

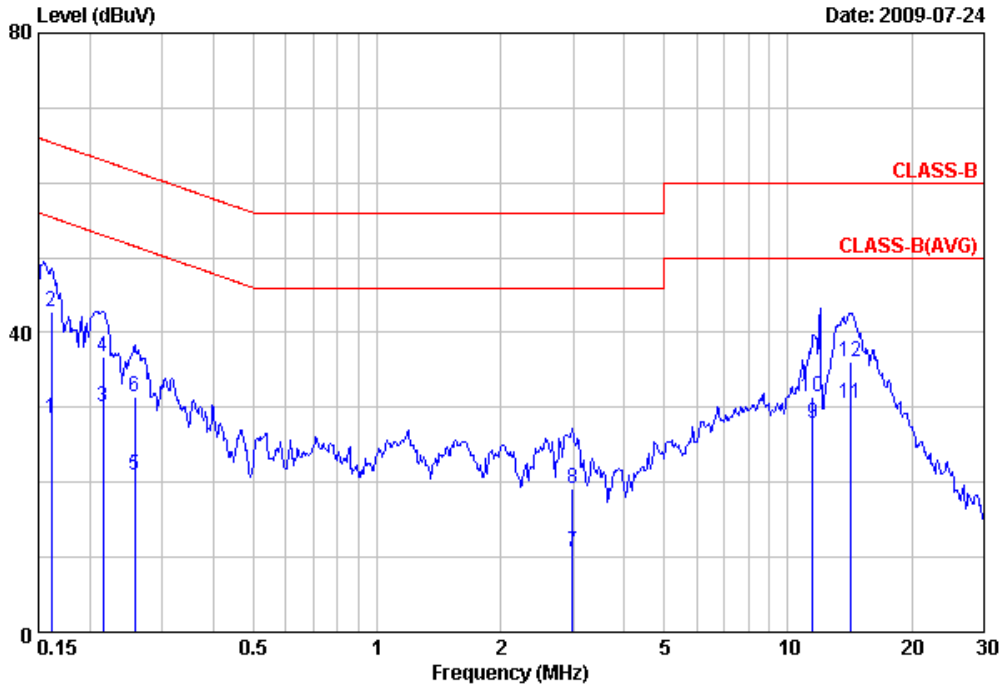

Item	Freq	Read Value	Factor	Result	Limit	Margin	Remark
	MHz	dBuV/m	dB	dBuV/m	dBuV/m	dB	
1	0.16	28.48	0.07	28.55	55.38	-26.83	Average
2	0.16	42.81	0.07	42.88	65.38	-22.50	QP
3	0.22	30.11	0.07	30.18	53.01	-22.83	Average
4	0.22	36.59	0.07	36.66	63.01	-26.35	QP
5	0.26	20.78	0.07	20.85	51.51	-30.66	Average
6	0.26	31.30	0.07	31.37	61.51	-30.14	QP
7	2.99	10.59	0.14	10.73	46.00	-35.27	Average
8	2.99	19.05	0.14	19.19	56.00	-36.81	QP
9	11.50	27.45	0.43	27.88	50.00	-22.12	Average
10	11.50	30.88	0.43	31.31	60.00	-28.69	QP
11	14.24	30.16	0.46	30.62	50.00	-19.38	Average
12	14.24	35.62	0.46	36.08	60.00	-23.92	QP

Notes:

1. Result = Read Value + Factor
2. Factor = LISN(ISN)Factor + Cable Loss
3. All emission below 1GHz at 802.11b/g mode are all the same,so the 802.11g mode chosen as representative in final test.
4. According to technical experiences,all spurious emission of 802.11g mode at channel 1,6,11 are almost the same below 1GHz,so that the channel 1 was chosen as representative in final test.
5. The data is worse case.





Power	: AC 120V	Pol/Phase	: LINE
Test Mode 1	: 802.11n, HT20, CH1	Temperature	: 25 °C
Memo	: Adapter: FA-1201500SUA	Humidity	: 65 %

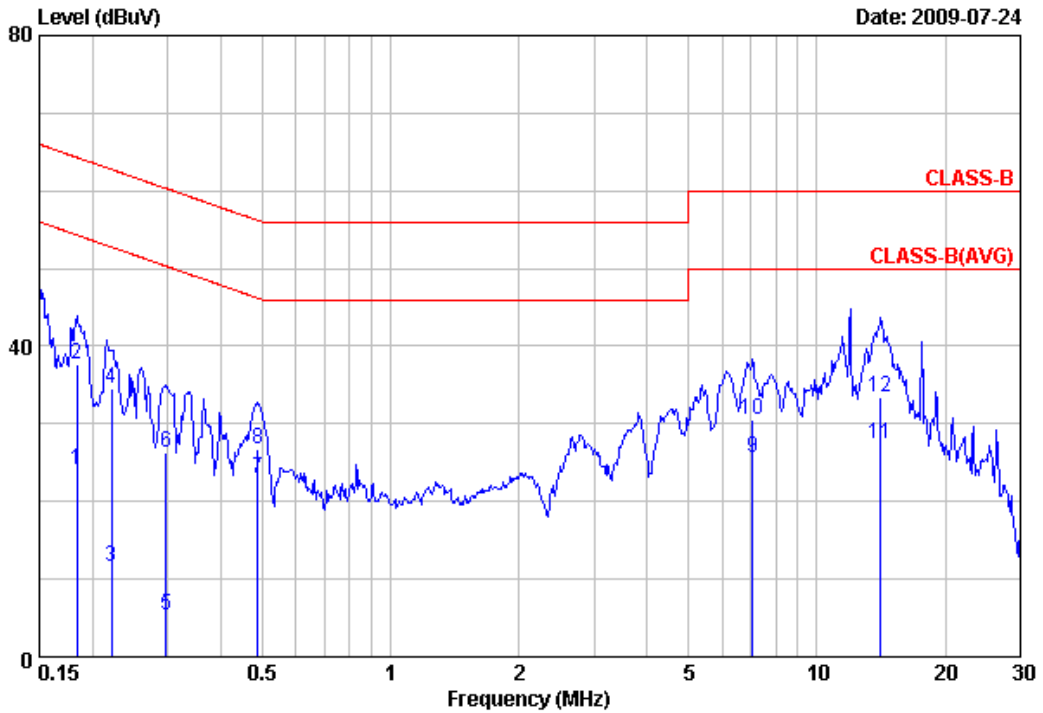

Item	Freq	Read Value	Factor	Result	Limit	Margin	Remark
	MHz	dBuV/m	dB	dBuV/m	dBuV/m	dB	
1	0.18	23.98	0.07	24.05	54.33	-30.28	Average
2	0.18	37.56	0.07	37.63	64.33	-26.70	QP
3	0.22	11.54	0.07	11.61	52.74	-41.13	Average
4	0.22	34.49	0.07	34.56	62.74	-28.18	QP
5	0.30	5.22	0.08	5.30	50.32	-45.02	Average
6	0.30	26.11	0.08	26.19	60.32	-34.13	QP
7	0.49	22.89	0.08	22.97	46.19	-23.22	Average
8	0.49	26.77	0.08	26.85	56.19	-29.34	QP
9	7.06	25.34	0.37	25.71	50.00	-24.29	Average
10	7.06	30.25	0.37	30.62	60.00	-29.38	QP
11	14.14	26.96	0.51	27.47	50.00	-22.53	Average
12	14.14	32.86	0.51	33.37	60.00	-26.63	QP

Notes:

1. Result = Read Value + Factor
2. Factor = LISN(ISN) Factor + Cable Loss
3. According to technical experiences, all spurious emission of 802.11MIMO mode at channel 1,6,11 are almost the same below 1GHz, so that the channel 1 was chosen as representative in final test.
4. The data is worse case.



Power	: AC 120V	Pol/Phase	: NEUTRAL
Test Mode 1	: 802.11n, HT20, CH1	Temperature	: 25 °C
Memo	: Adapter: FA-1201500SUA	Humidity	: 65 %

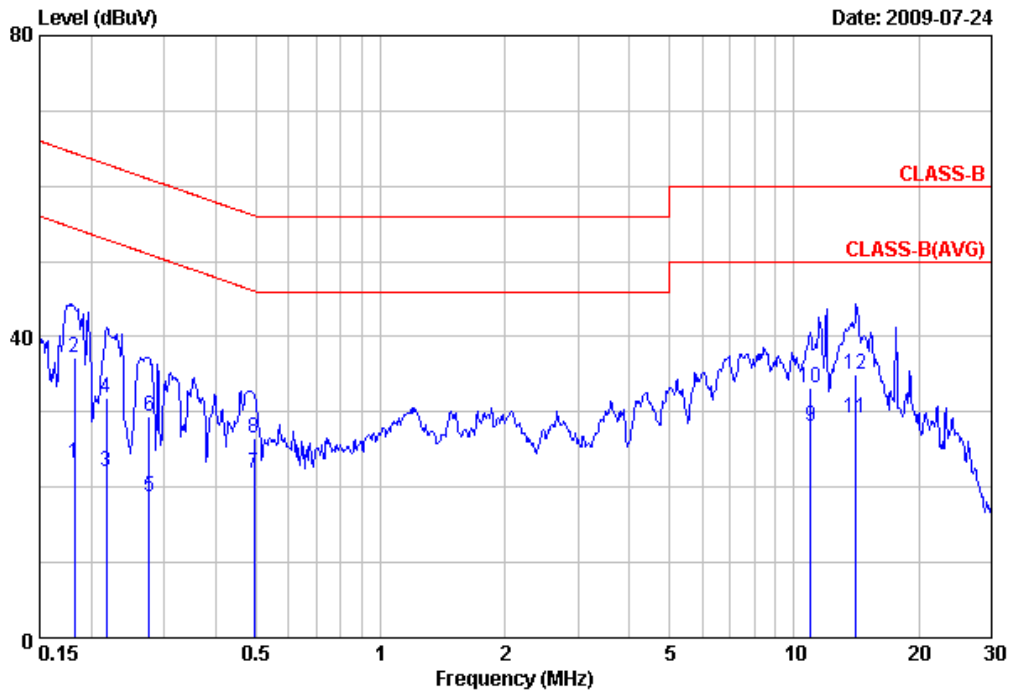

Item	Freq	Read Value	Factor	Result	Limit	Margin	Remark
	MHz	dBuV/m	dB	dBuV/m	dBuV/m	dB	
1	0.18	23.18	0.07	23.25	54.37	-31.12	Average
2	0.18	37.18	0.07	37.25	64.37	-27.12	QP
3	0.22	21.99	0.07	22.06	52.92	-30.86	Average
4	0.22	31.76	0.07	31.83	62.92	-31.09	QP
5	0.28	18.73	0.07	18.80	50.94	-32.14	Average
6	0.28	29.33	0.07	29.40	60.94	-31.54	QP
7	0.49	21.66	0.08	21.74	46.10	-24.36	Average
8	0.49	26.53	0.08	26.61	56.10	-29.49	QP
9	10.96	27.74	0.41	28.15	50.00	-21.85	Average
10	10.96	32.74	0.41	33.15	60.00	-26.85	QP
11	14.14	28.78	0.46	29.24	50.00	-20.76	Average
12	14.14	34.47	0.46	34.93	60.00	-25.07	QP

Notes:

1. Result = Read Value + Factor
2. Factor = LISN(ISN)Factor + Cable Loss
3. According to technical experiences, all spurious emission of 802.11MIMO mode at channel 1,6,11 are almost the same below 1GHz, so that the channel 1 was chosen as representative in final test.
4. The data is worse case.



Power	: AC 120V	Pol/Phase	: LINE
Test Mode 1	: 802.11n, HT40, CH3	Temperature	: 25 °C
Memo	: Adapter: FA-1201500SUA	Humidity	: 65 %

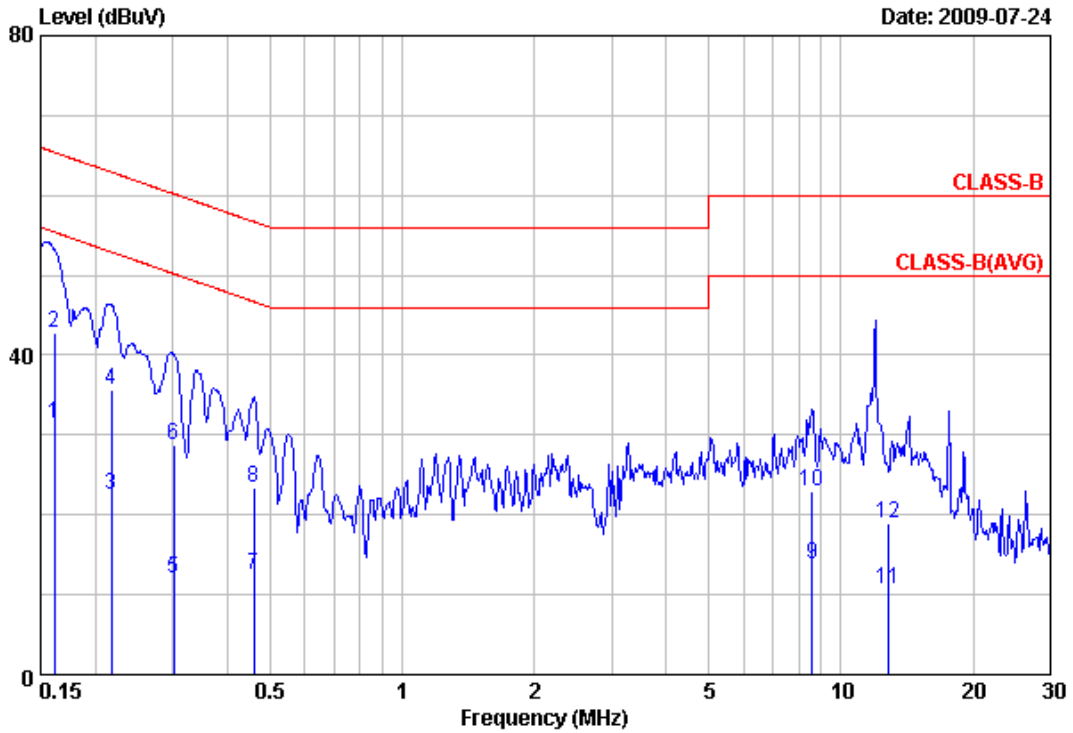

Item	Freq	Read Value	Factor	Result	Limit	Margin	Remark
	MHz	dBuV/m	dB	dBuV/m	dBuV/m	dB	
1	0.16	31.25	0.07	31.32	55.38	-24.06	Average
2	0.16	42.82	0.07	42.89	65.38	-22.49	QP
3	0.22	22.54	0.07	22.61	52.92	-30.31	Average
4	0.22	35.63	0.07	35.70	62.92	-27.22	QP
5	0.30	11.86	0.08	11.94	50.19	-38.25	Average
6	0.30	28.72	0.08	28.80	60.19	-31.39	QP
7	0.46	12.30	0.08	12.38	46.71	-34.33	Average
8	0.46	23.29	0.08	23.37	56.71	-33.34	QP
9	8.59	13.31	0.41	13.72	50.00	-36.28	Average
10	8.59	22.47	0.41	22.88	60.00	-37.12	QP
11	12.86	10.26	0.52	10.78	50.00	-39.22	Average
12	12.86	18.47	0.52	18.99	60.00	-41.01	QP

Notes:

1. Result = Read Value + Factor
2. Factor = LISN(ISN) Factor + Cable Loss
3. According to technical experiences, all spurious emission of 802.11MIMO mode at channel 3,6,9 are almost the same below 1GHz, so that the channel 3 was chosen as representative in final test.
4. The data is worse case.



Power	: AC 120V	Pol/Phase	: NEUTRAL
Test Mode 1	: 802.11n, HT40, CH3	Temperature	: 25 °C
Memo	: Adapter: FA-1201500SUA	Humidity	: 65 %

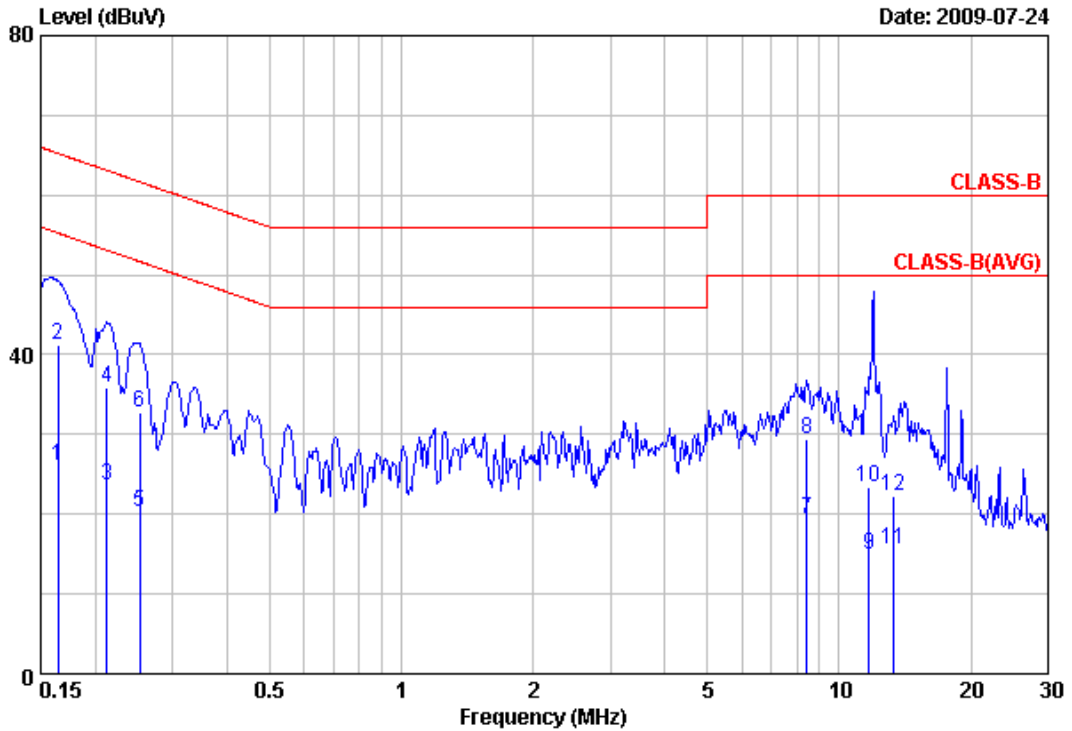

Item	Freq	Read Value	Factor	Result	Limit	Margin	Remark
	MHz	dBuV/m	dB	dBuV/m	dBuV/m	dB	
1	0.16	25.99	0.07	26.06	55.25	-29.19	Average
2	0.16	41.17	0.07	41.24	65.25	-24.01	QP
3	0.21	23.52	0.07	23.59	53.10	-29.51	Average
4	0.21	35.72	0.07	35.79	63.10	-27.31	QP
5	0.25	20.30	0.07	20.37	51.69	-31.32	Average
6	0.25	32.67	0.07	32.74	61.69	-28.95	QP
7	8.46	19.07	0.32	19.39	50.00	-30.61	Average
8	8.46	29.06	0.32	29.38	60.00	-30.62	QP
9	11.68	14.55	0.43	14.98	50.00	-35.02	Average
10	11.68	22.98	0.43	23.41	60.00	-36.59	QP
11	13.29	15.19	0.44	15.63	50.00	-34.37	Average
12	13.29	21.89	0.44	22.33	60.00	-37.67	QP

Notes:

1. Result = Read Value + Factor
2. Factor = LISN(ISN)Factor + Cable Loss
3. According to technical experiences, all spurious emission of 802.11MIMO mode at channel 3,6,9 are almost the same below 1GHz, so that the channel 3 was chosen as representative in final test.
4. The data is worse case.



Power	: AC 120V	Pol/Phase	: LINE
Test Mode 2	: 802.11g, CH1	Temperature	: 25 °C
Memo	: Adapter: AD661F0916BLF	Humidity	: 65 %

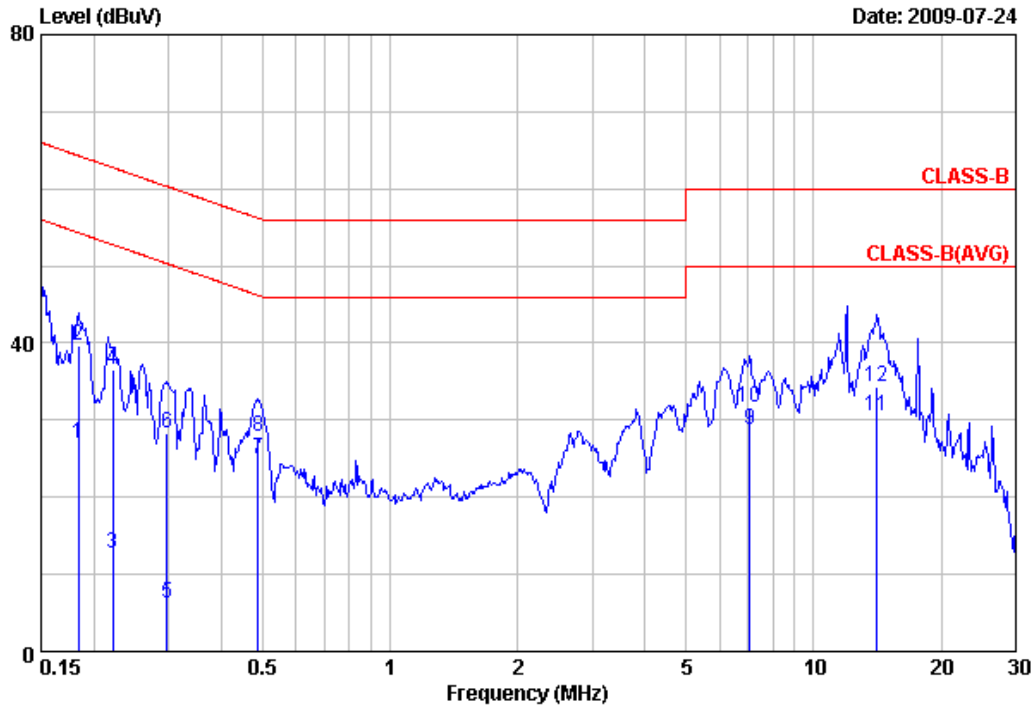

Item	Freq	Read Value	Factor	Result	Limit	Margin	Remark
	MHz	dBuV/m	dB	dBuV/m	dBuV/m	dB	
1	0.18	26.98	0.07	27.05	54.33	-27.28	Average
2	0.18	39.56	0.07	39.63	64.33	-24.70	QP
3	0.22	12.54	0.07	12.61	52.74	-40.13	Average
4	0.22	36.49	0.07	36.56	62.74	-26.18	QP
5	0.30	6.22	0.08	6.30	50.32	-44.02	Average
6	0.30	28.11	0.08	28.19	60.32	-32.13	QP
7	0.49	24.89	0.08	24.97	46.19	-21.22	Average
8	0.49	27.77	0.08	27.85	56.19	-28.34	QP
9	7.06	28.34	0.37	28.71	50.00	-21.29	Average
10	7.06	31.25	0.37	31.62	60.00	-28.38	QP
11	14.14	29.96	0.51	30.47	50.00	-19.53	Average
12	14.14	33.86	0.51	34.37	60.00	-25.63	QP

Notes:

1. Result = Read Value + Factor
2. Factor = LISN(ISN)Factor + Cable Loss
3. All emission below 1GHz at 802.11g mode are all the same,so the 802.11g mode chosen as representative in final test.
4. According to technical experiences,all spurious emission of 802.11g mode at channel 1,6,11 are almost the same below 1GHz,so that the channel 1 was chosen as representative in final test.
5. The data is worse case.



Power	: AC 120V	Pol/Phase	: NEUTRAL
Test Mode 2	: 802.11g, CH1	Temperature	: 25 °C
Memo	: Adapter: AD661F0916BLF	Humidity	: 65 %

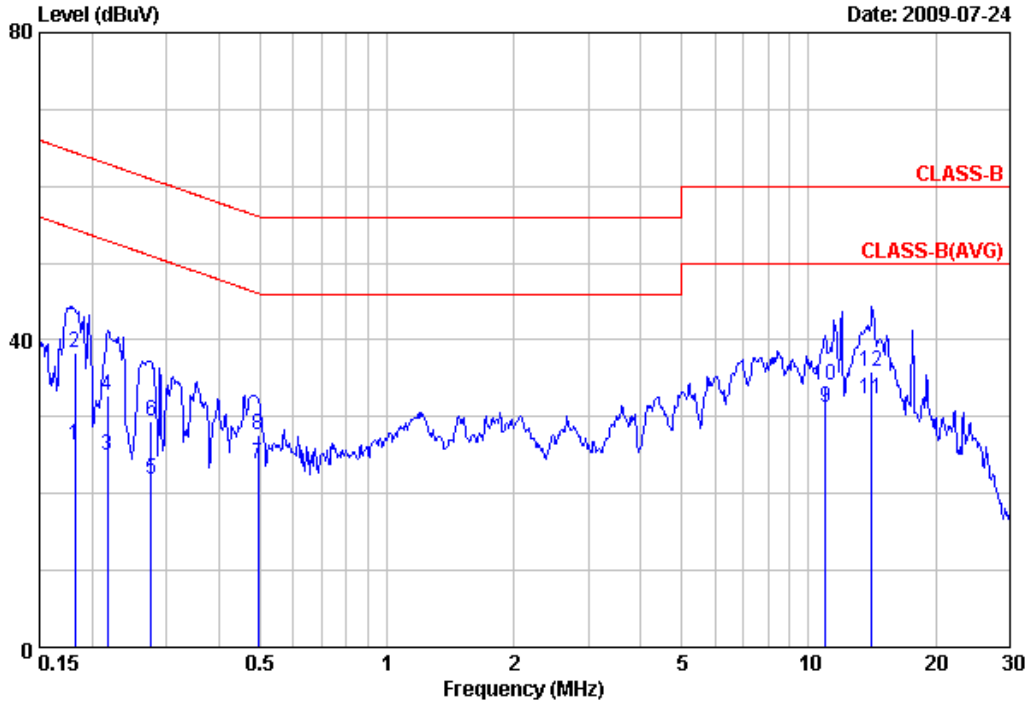

Item	Freq	Read Value	Factor	Result	Limit	Margin	Remark
	MHz	dBuV/m	dB	dBuV/m	dBuV/m	dB	
1	0.18	26.18	0.07	26.25	54.37	-28.12	Average
2	0.18	38.18	0.07	38.25	64.37	-26.12	QP
3	0.22	24.99	0.07	25.06	52.92	-27.86	Average
4	0.22	32.76	0.07	32.83	62.92	-30.09	QP
5	0.28	21.73	0.07	21.80	50.94	-29.14	Average
6	0.28	29.33	0.07	29.40	60.94	-31.54	QP
7	0.49	23.66	0.08	23.74	46.10	-22.36	Average
8	0.49	27.53	0.08	27.61	56.10	-28.49	QP
9	10.96	30.74	0.41	31.15	50.00	-18.85	Average
10	10.96	33.74	0.41	34.15	60.00	-25.85	QP
11	14.14	31.78	0.46	32.24	50.00	-17.76	Average
12	14.14	35.47	0.46	35.93	60.00	-24.07	QP

Notes:

1. Result = Read Value + Factor
2. Factor = LISN(ISN)Factor + Cable Loss
3. All emission below 1GHz at 802.11g mode are all the same,so the 802.11g mode chosen as representative in final test.
4. According to technical experiences,all spurious emission of 802.11g mode at channel 1,6,11 are almost the same below 1GHz,so that the channel 1 was chosen as representative in final test.
5. The data is worse case.



Power	: AC 120V	Pol/Phase	: LINE
Test Mode 2	: 802.11n, HT20, CH1	Temperature	: 25 °C
Memo	: Adapter: AD661F0916BLF	Humidity	: 65 %

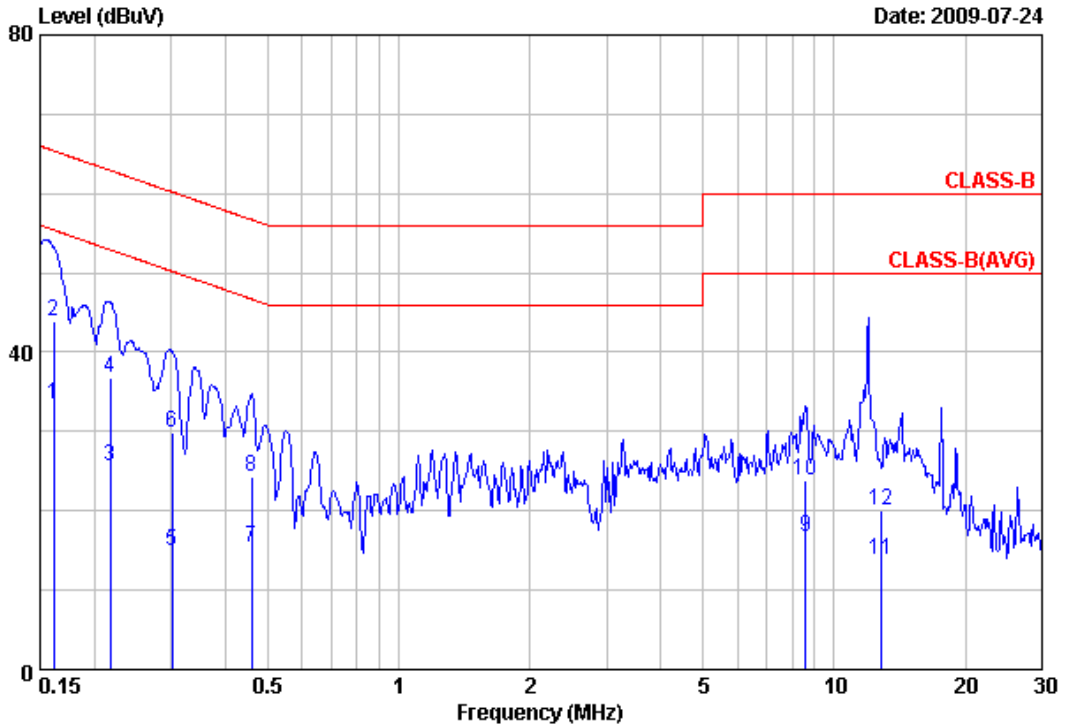

Item	Freq	Read Value	Factor	Result	Limit	Margin	Remark
	MHz	dBuV/m	dB	dBuV/m	dBuV/m	dB	
1	0.16	33.25	0.07	33.32	55.38	-22.06	Average
2	0.16	43.82	0.07	43.89	65.38	-21.49	QP
3	0.22	25.54	0.07	25.61	52.92	-27.31	Average
4	0.22	36.63	0.07	36.70	62.92	-26.22	QP
5	0.30	14.86	0.08	14.94	50.19	-35.25	Average
6	0.30	29.72	0.08	29.80	60.19	-30.39	QP
7	0.46	15.30	0.08	15.38	46.71	-31.33	Average
8	0.46	24.29	0.08	24.37	56.71	-32.34	QP
9	8.59	16.31	0.41	16.72	50.00	-33.28	Average
10	8.59	23.47	0.41	23.88	60.00	-36.12	QP
11	12.86	13.26	0.52	13.78	50.00	-36.22	Average
12	12.86	19.47	0.52	19.99	60.00	-40.01	QP

Notes:

1. Result = Read Value + Factor
2. Factor = LISN(ISN)Factor + Cable Loss
3. According to technical experiences, all spurious emission of 802.11MIMO mode at channel 1,6,11 are almost the same below 1GHz, so that the channel 1 was chosen as representative in final test.
4. The data is worse case.



Power	: AC 120V	Pol/Phase	: NEUTRAL
Test Mode 2	: 802.11n, HT20, CH1	Temperature	: 25 °C
Memo	: Adapter: AD661F0916BLF	Humidity	: 65 %

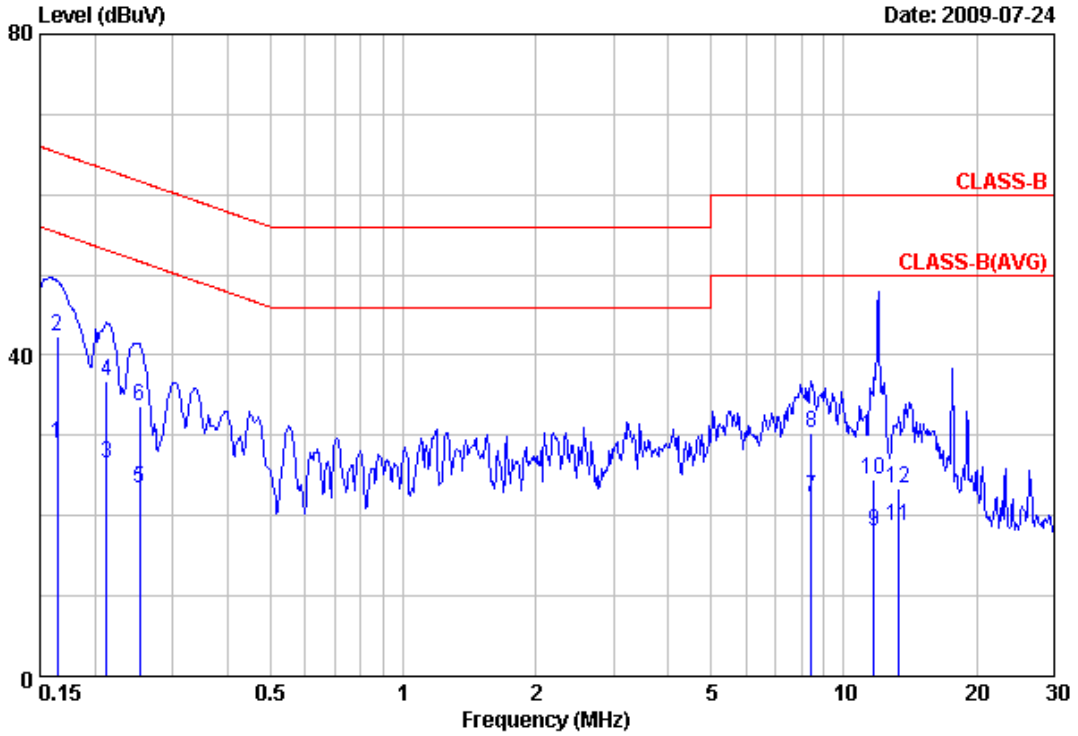

Item	Freq	Read Value	Factor	Result	Limit	Margin	Remark
	MHz	dBuV/m	dB	dBuV/m	dBuV/m	dB	
1	0.16	28.99	0.07	29.06	55.25	-26.19	Average
2	0.16	42.17	0.07	42.24	65.25	-23.01	QP
3	0.21	26.52	0.07	26.59	53.10	-26.51	Average
4	0.21	36.72	0.07	36.79	63.10	-26.31	QP
5	0.25	23.30	0.07	23.37	51.69	-28.32	Average
6	0.25	33.67	0.07	33.74	61.69	-27.95	QP
7	8.46	22.07	0.32	22.39	50.00	-27.61	Average
8	8.46	30.06	0.32	30.38	60.00	-29.62	QP
9	11.68	17.55	0.43	17.98	50.00	-32.02	Average
10	11.68	23.98	0.43	24.41	60.00	-35.59	QP
11	13.29	18.19	0.44	18.63	50.00	-31.37	Average
12	13.29	22.89	0.44	23.33	60.00	-36.67	QP

Notes:

1. Result = Read Value + Factor
2. Factor = LISN(ISN)Factor + Cable Loss
3. According to technical experiences, all spurious emission of 802.11MIMO mode at channel 1,6,11 are almost the same below 1GHz, so that the channel 1 was chosen as representative in final test.
4. The data is worse case.





Power	: AC 120V	Pol/Phase	: LINE
Test Mode 2	: 802.11n, HT40, CH3	Temperature	: 25 °C
Memo	: Adapter: AD661F0916BLF	Humidity	: 65 %

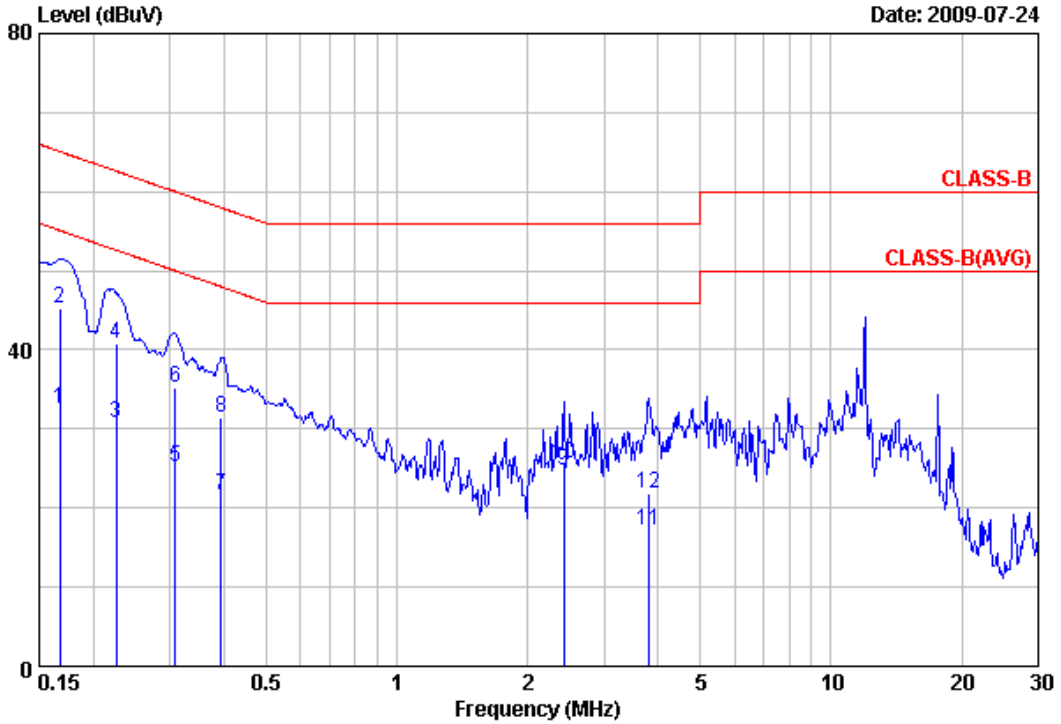

Item	Freq	Read Value	Factor	Result	Limit	Margin	Remark
	MHz	dBuV/m	dB	dBuV/m	dBuV/m	dB	
1	0.17	32.38	0.07	32.45	55.08	-22.63	Average
2	0.17	45.24	0.07	45.31	65.08	-19.77	QP
3	0.23	30.74	0.07	30.81	52.61	-21.80	Average
4	0.23	40.65	0.07	40.72	62.61	-21.89	QP
5	0.31	25.21	0.08	25.29	50.02	-24.73	Average
6	0.31	35.17	0.08	35.25	60.02	-24.77	QP
7	0.39	21.57	0.08	21.65	47.99	-26.34	Average
8	0.39	31.33	0.08	31.41	57.99	-26.58	QP
9	2.42	24.52	0.13	24.65	46.00	-21.35	Average
10	2.42	25.51	0.13	25.64	56.00	-30.36	QP
11	3.80	17.02	0.18	17.20	46.00	-28.80	Average
12	3.80	21.66	0.18	21.84	56.00	-34.16	QP

Notes:

1. Result = Read Value + Factor
2. Factor = LISN(ISN)Factor + Cable Loss
3. According to technical experiences, all spurious emission of 802.11MIMO mode at channel 3,6,9 are almost the same below 1GHz, so that the channel 3 was chosen as representative in final test.
4. The data is worse case.



Power	: AC 120V	Pol/Phase	: NEUTRAL
Test Mode 2	: 802.11n, HT40, CH3	Temperature	: 25 °C
Memo	: Adapter: AD661F0916BLF	Humidity	: 65 %

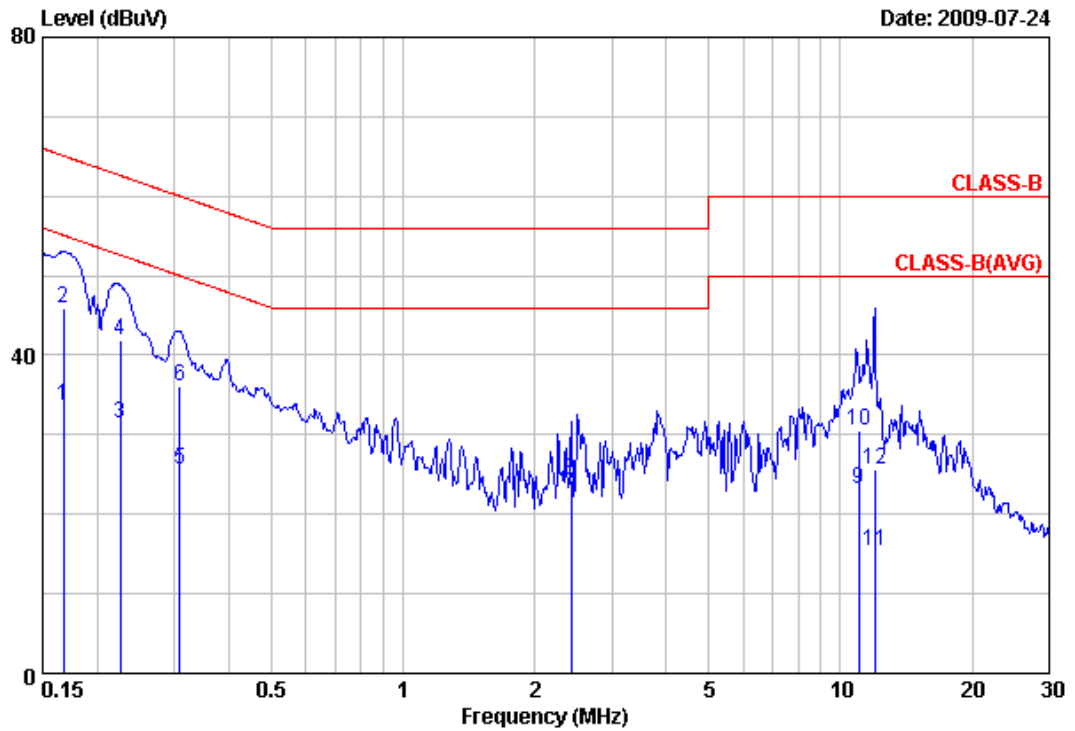

Item	Freq	Read Value	Factor	Result	Limit	Margin	Remark
	MHz	dBuV/m	dB	dBuV/m	dBuV/m	dB	
1	0.17	33.50	0.07	33.57	55.08	-21.51	Average
2	0.17	45.89	0.07	45.96	65.08	-19.12	QP
3	0.23	31.24	0.07	31.31	52.61	-21.30	Average
4	0.23	41.79	0.07	41.86	62.61	-20.75	QP
5	0.31	25.56	0.08	25.64	50.02	-24.38	Average
6	0.31	35.98	0.08	36.06	60.02	-23.96	QP
7	2.42	22.34	0.16	22.50	46.00	-23.50	Average
8	2.42	24.19	0.16	24.35	56.00	-31.65	QP
9	11.03	22.67	0.51	23.18	50.00	-26.82	Average
10	11.03	29.92	0.51	30.43	60.00	-29.57	QP
11	12.05	14.80	0.54	15.34	50.00	-34.66	Average
12	12.05	25.11	0.54	25.65	60.00	-34.35	QP

Notes:

1. Result = Read Value + Factor
2. Factor = LISN(ISN)Factor + Cable Loss
3. According to technical experiences, all spurious emission of 802.11MIMO mode at channel 3,6,9 are almost the same below 1GHz, so that the channel 3 was chosen as representative in final test.
4. The data is worse case.

Test engineer: Ben



## 5. Test of Radiated Emission

### 5.1 Test Limit

Radiated emissions from 30 MHz to 25 GHz were measured according to the methods defines in ANSI C63.4-2003. The EUT was placed, 0.8 meter above the ground plane, as shown in section 5.6.3. The interface cables and equipment positions were varied within limits of reasonable applications to determine the positions producing maximum radiated emissions

For unintentional device, according to § 15.109(a), except for Class A digital devices, the field strength of radiated emissions from unintentional radiators at a distance of 3 meters shall not exceed the following values:

Frequency (MHz)	Distance Meters	Radiated ( $\mu$ V / M)	Radiated (dB $\mu$ V/ M)
30-88	3	100	40.0
88-216	3	150	43.5
216-960	3	200	46.0
Above 960	3	500	54.0

For unintentional device, according to CISPR PUB.22, for Class B digital devices, the general requirement of field strength of radiated emissions from intentional radiators at a distance of 10 meters shall not exceed the below table.

Frequency (MHz)	Distance Meters	Radiated (dB $\mu$ V/ M)
30-230	10	30
230-1000	10	37

### 5.2 Test Procedures

- The EUT was placed on a rotatable table top 0.8 meter above ground.
- The EUT was set 3 meters from the interference receiving antenna which was mounted on the top of a variable height antenna tower.
- The table was rotated 360 degrees to determine the position of the highest radiation.
- The antenna is a broadband antenna and its height is varied between one meter and four meters above ground to find the maximum value of the field strength both horizontal polarization and vertical polarization of the antenna are set to make the measurement.
- For each suspected emission the EUT was arranged to its worst case and then tune the antenna tower (from 1 M to 4 M) and turn table (from 0 degree to 360 degrees) to find the maximum reading.
- Set the test-receiver system to Peak or CISPR quasi-peak Detect Function and specified bandwidth with Maximum Hold Mode.
- If the emission level of the EUT in peak mode was 3 dB lower than the limit specified, then testing will be stopped and peak values of EUT will be reported, otherwise, the emissions which do not have 3 dB margin will be repeated one by one using the quasi-peak method and reported.
- For testing above 1GHz, the emission level of the EUT in peak mode was 20dB lower than average limit (that means the emission level in peak mode also complies with the limit in average mode), then testing will be stopped and peak values of EUT will be reported, otherwise, the emissions will be measured in average mode again and reported.
- “ Cone of radiation” has been considered to be 3dB beamwidth of the measurement antenna.



### 5.3 Typical Test Setup

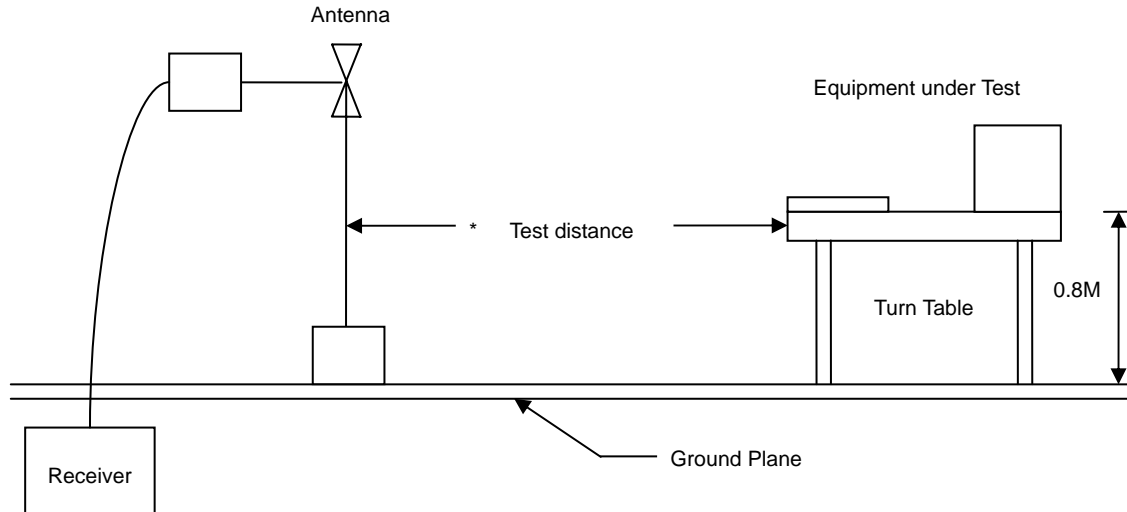

### 5.4 Measurement equipment

Instrument/Ancillary	Manufacturer	Model No.	Serial No.	Calibration Date	Valid Date
Bilog Antenna	Schaffner	CBL6112B	2840	2009/05/14	2010/05/13
Signal Generator	HP	8648B	3629U00612	2008/10/08	2009/10/07
Amplifier	Agilent	8447D	2944A10593	2009/05/21	2010/05/20
EMI Receiver	HP	8546A	3807A00454	2008/08/07	2009/08/06
Spectrum Analyzer	R&S	FSP40	100047	2009/03/26	2010/03/25
Horn Antenna	EMCO	3115	31589	2009/05/04	2010/05/03
Preamplifier	Agilent	8449B	3008A01954	2009/02/27	2010/02/26



## 5.5 Test Result and Data

Power	: AC 120V	Pol/Phase	: VERTICAL
Test Mode 1	: Transmit / Receive	Temperature	: 26 °C
Operation Channel	: 1	Humidity	: 58 %
Modulation Type	: 802.11g	Atmospheric Pressure	: 1023 hPa
Memo	: Adapter:AD-1201500SUA	Rate	: 6 Mbps

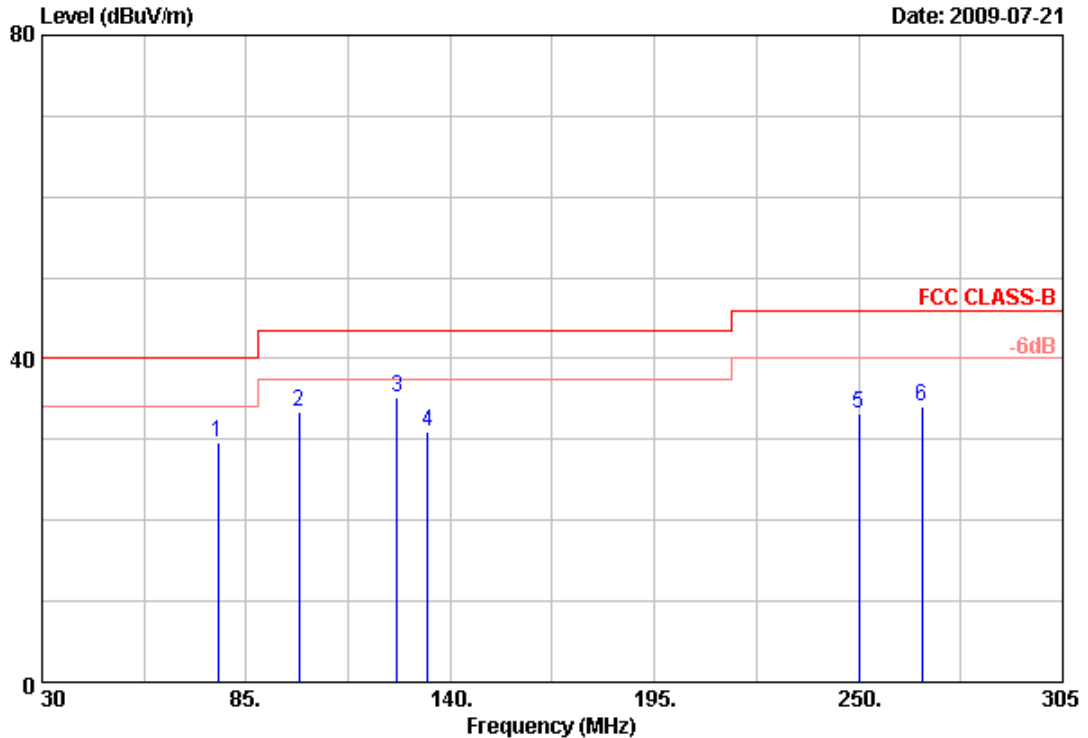

Item	Freq	Read Value	Factor	Result	Limit	Margin	Remark	Ant Pos	Tab Pos
	MHz	dBuV/m	dB	dBuV/m	dBuV/m	dB		cm	Deg
1	77.30	44.52	-14.85	29.67	40.00	-10.33	Peak	100	360
2	99.30	45.05	-11.72	33.33	43.50	-10.17	Peak	100	360
3	125.70	44.41	-9.31	35.10	43.50	-8.40	Peak	100	360
4	133.95	40.63	-9.67	30.96	43.50	-12.54	Peak	100	360
5	250.00	45.92	-12.64	33.28	46.00	-12.72	Peak	100	360
6	267.05	46.71	-12.54	34.17	46.00	-11.83	Peak	100	360

## Notes:

1. Result = Read Value + Factor
2. Factor = Antenna Factor + Cable Loss - Amplifier
3. The resolution bandwidth of test receiver/spectrum analyzer is 120KHz and video bandwidth is 300kHz for Peak detection and Quasi-peak detection at frequency below 1GHz.
4. All emission below 1GHz at 802.11b/g mode are all the same, so the 802.11g mode chosen as representative in final test.
5. According to technical experiences, all spurious emission of 802.11b mode at channel 1, 6, 11 are almost the same below 1GHz, so that the channel 1 was chosen as representative in final test.
6. The data is worse case.



Power	: AC 120V	Pol/Phase	: VERTICAL
Test Mode 1	: Transmit / Receive	Temperature	: 26 °C
Operation Channel	: 1	Humidity	: 58 %
Modulation Type	: 802.11g	Atmospheric Pressure	: 1023 hPa
Memo	: Adapter:AD-1201500SUA	Rate	: 6 Mbps

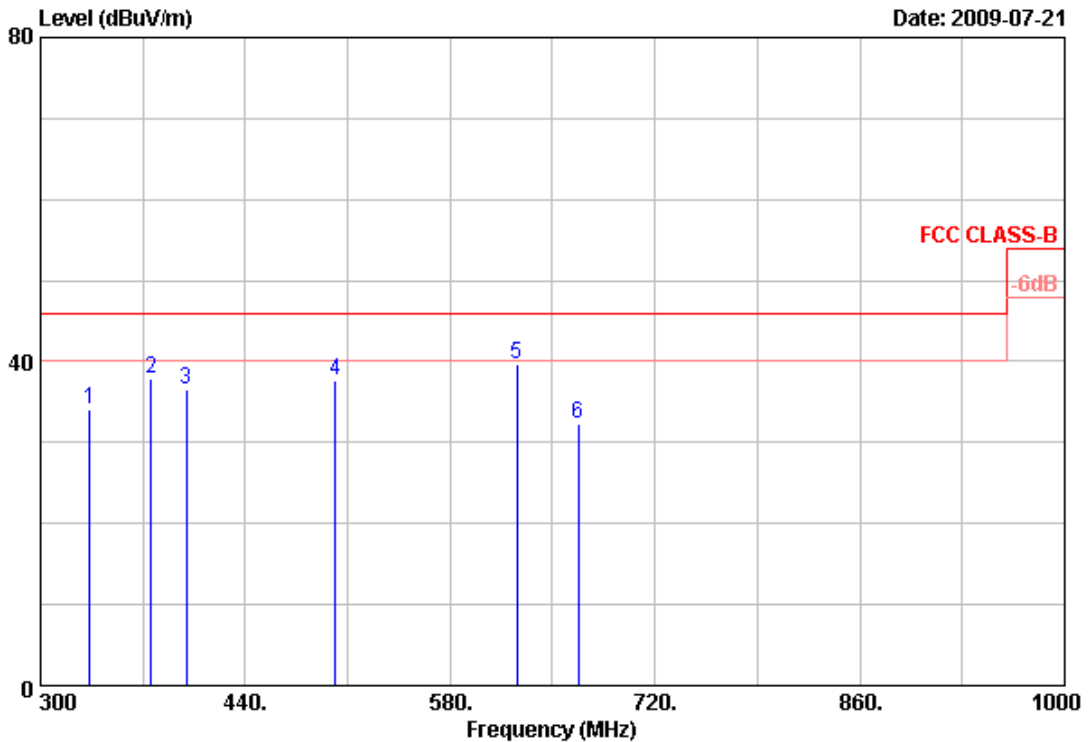

Item	Freq	Read Value	Factor	Result	Limit	Margin	Remark	Ant Pos	Tab Pos
	MHz	dBuV/m	dB	dBuV/m	dBuV/m	dB		cm	Deg
1	333.60	45.47	-11.43	34.04	46.00	-11.96	Peak	100	0
2	375.60	48.19	-10.31	37.88	46.00	-8.12	Peak	100	0
3	399.40	43.60	-6.97	36.63	46.00	-9.37	Peak	100	0
4	501.60	46.20	-8.44	37.76	46.00	-8.24	Peak	100	0
5	625.50	46.27	-6.52	39.75	46.00	-6.25	Peak	100	0
6	667.50	36.23	-3.94	32.29	46.00	-13.71	Peak	100	0

Notes:

1. Result = Read Value + Factor
2. Factor = Antenna Factor + Cable Loss - Amplifier
3. The resolution bandwidth of test receiver/spectrum analyzer is 120KHz and video bandwidth is 300kHz for Peak detection and Quasi-peak detection at frequency below 1GHz.
4. All emission below 1GHz at 802.11b/g mode are all the same, so the 802.11g mode chosen as representative in final test.
5. According to technical experiences, all spurious emission of 802.11b mode at channel 1, 6, 11 are almost the same below 1GHz, so that the channel 1 was chosen as representative in final test.
6. The data is worse case.



Power	: AC 120V	Pol/Phase	: HORIZONTAL
Test Mode 1	: Transmit / Receive	Temperature	: 26 °C
Operation Channel	: 1	Humidity	: 58 %
Modulation Type	: 802.11g	Atmospheric Pressure	: 1023 hPa
Memo	: Adapter:AD-1201500SUA	Rate	: 6 Mbps

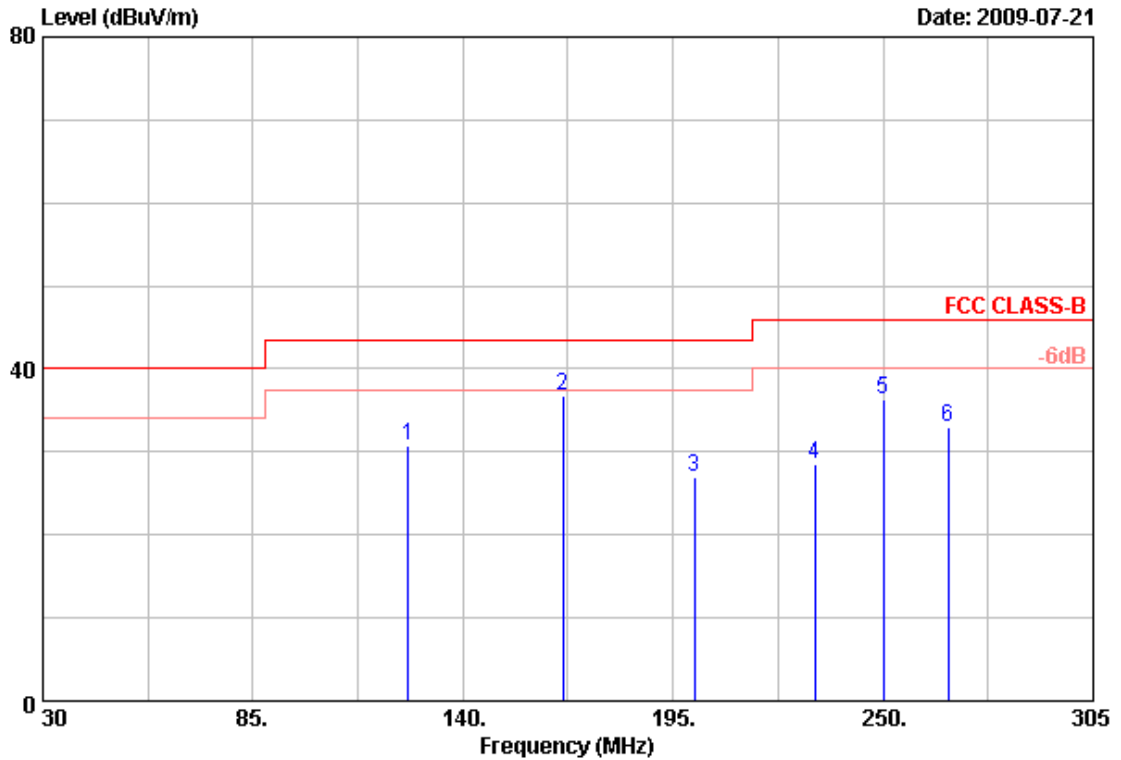

Item	Freq	Read Value	Factor	Result	Limit	Margin	Remark	Ant Pos	Tab Pos
	MHz	dBuV/m	dB	dBuV/m	dBuV/m	dB		cm	Deg
1	125.70	47.47	-16.64	30.83	43.50	-12.67	Peak	100	360
2	166.13	53.90	-17.13	36.77	43.50	-6.73	Peak	100	360
3	200.50	44.23	-17.21	27.02	43.50	-16.48	Peak	100	360
4	232.13	44.54	-16.12	28.42	46.00	-17.58	Peak	100	360
5	250.00	51.59	-15.28	36.31	46.00	-9.69	Peak	100	360
6	267.05	46.54	-13.53	33.01	46.00	-12.99	Peak	100	360

Notes:

1. Result = Read Value + Factor
2. Factor = Antenna Factor + Cable Loss - Amplifier
3. The resolution bandwidth of test receiver/spectrum analyzer is 120KHz and video bandwidth is 300kHz for Peak detection and Quasi-peak detection at frequency below 1GHz.
4. All emission below 1GHz at 802.11b/g mode are all the same,so the 802.11g mode chosen as representative in final test.
5. According to technical experiences,all spurious emission of 802.11b mode at channel 1,6,11 are almost the same below 1GHz,so that the channel 1 was chosen as representative in final test.
6. The data is worse case.



Power	: AC 120V	Pol/Phase	: HORIZONTAL
Test Mode 1	: Transmit / Receive	Temperature	: 26 °C
Operation Channel	: 1	Humidity	: 58 %
Modulation Type	: 802.11g	Atmospheric Pressure	: 1023 hPa
Memo	: Adapter:AD-1201500SUA	Rate	: 6 Mbps

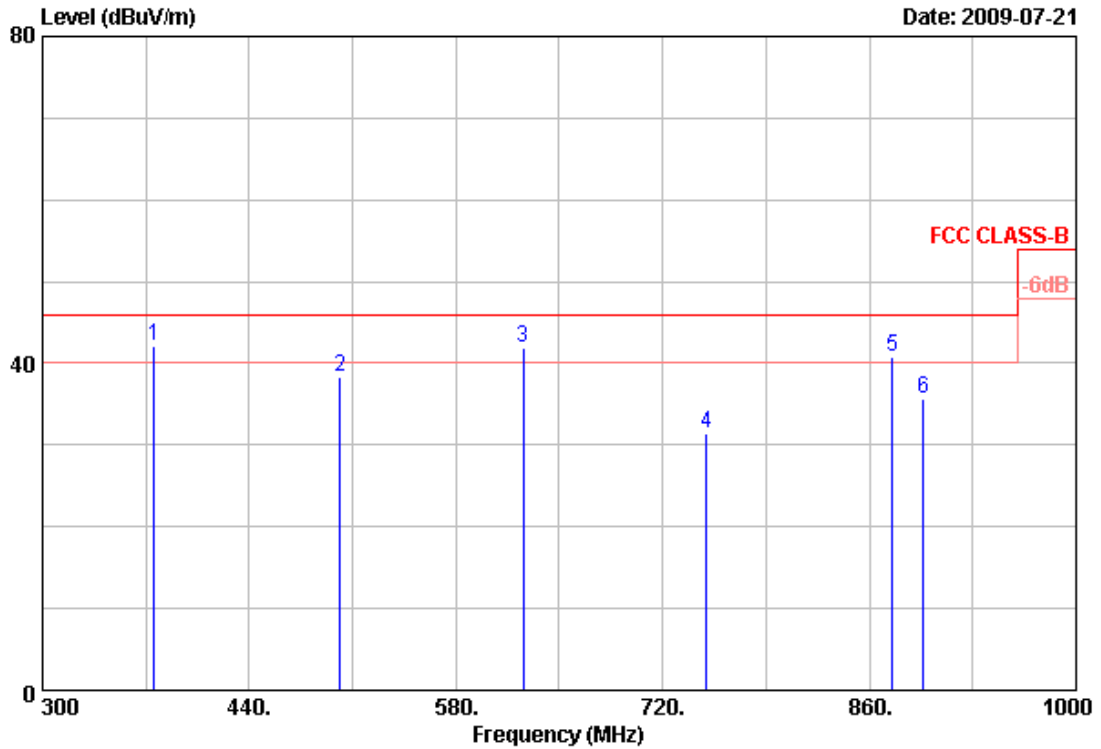

Item	Freq	Read Value	Factor	Result	Limit	Margin	Remark	Ant Pos	Tab Pos
	MHz	dBuV/m	dB	dBuV/m	dBuV/m	dB		cm	Deg
1	375.60	53.89	-11.68	42.21	46.00	-3.79	QP	100	0
2	501.60	43.70	-5.42	38.28	46.00	-7.72	Peak	100	0
3	625.50	43.36	-1.45	41.91	46.00	-4.09	QP	100	0
4	749.40	33.18	-1.85	31.33	46.00	-14.67	Peak	100	0
5	875.40	40.68	0.06	40.74	46.00	-5.26	QP	100	0
6	896.40	34.22	1.46	35.68	46.00	-10.32	Peak	100	0

Notes:

1. Result = Read Value + Factor
2. Factor = Antenna Factor + Cable Loss - Amplifier
3. The resolution bandwidth of test receiver/spectrum analyzer is 120KHz and video bandwidth is 300kHz for Peak detection and Quasi-peak detection at frequency below 1GHz.
4. All emission below 1GHz at 802.11b/g mode are all the same,so the 802.11g mode chosen as representative in final test.
5. According to technical experiences,all spurious emission of 802.11b mode at channel 1,6,11 are almost the same below 1GHz,so that the channel 1 was chosen as representative in final test.
6. The data is worse case.





Power	: AC 120V	Pol/Phase	: VERTICAL
Test Mode 1	: Transmit / Receive	Temperature	: 26 °C
Operation Channel	: 1	Humidity	: 58 %
Modulation Type	: 802.11b	Atmospheric Pressure	: 1023 hPa
Memo	: Adapter:FA-1201500SUA	Rate	: 11 Mbps

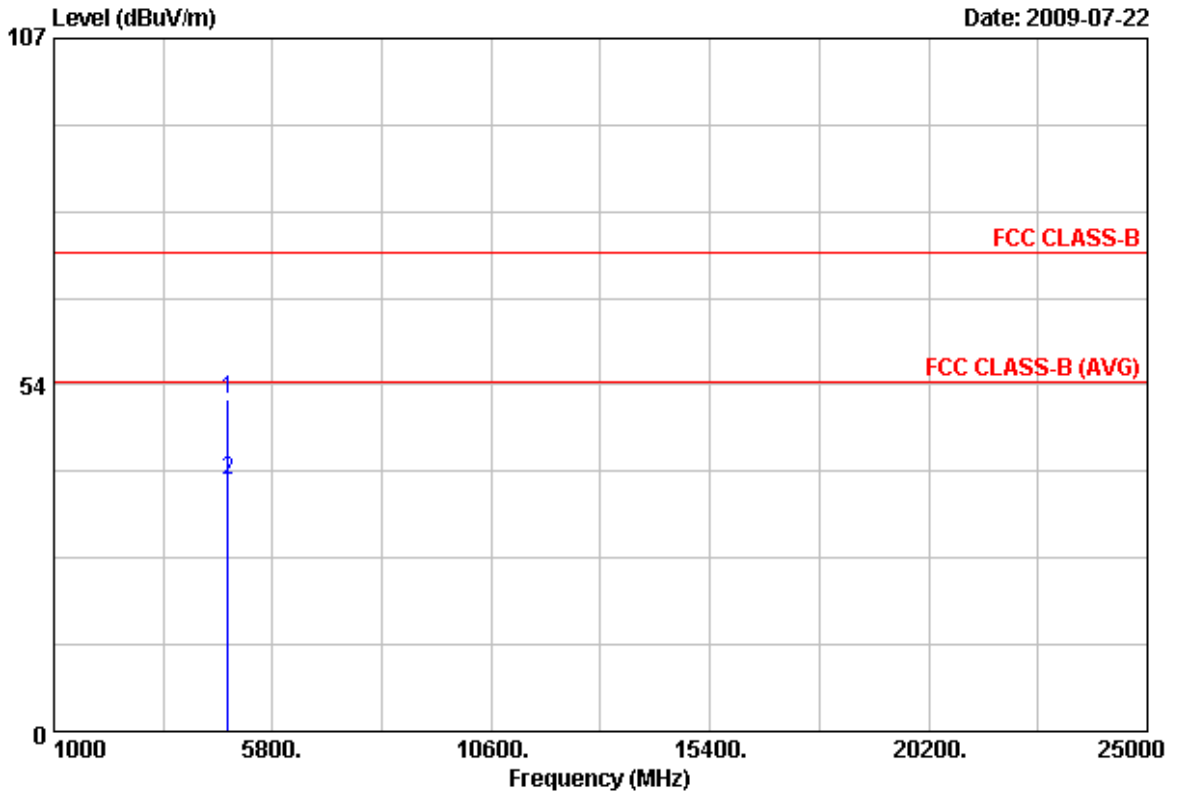

Item	Freq	Read Value	Factor	Result	Limit	Margin	Remark	Ant Pos	Tab Pos
	MHz	dBuV/m	dB	dBuV/m	dBuV/m	dB		cm	Deg
1	4822.85	46.04	5.33	51.37	74.00	-22.63	Peak	100	360
2	4823.60	33.52	5.33	38.85	54.00	-15.15	Average	100	360

Notes:

1. Result = Read Value + Factor
2. Factor = Antenna Factor + Cable Loss - Amplifier
3. The resolution bandwidth of test receiver/spectrum analyzer is 120KHz and video bandwidth is 300kHz for Peak detection and Quasi-peak detection at frequency below 1GHz.
4. The resolution bandwidth of test receiver/spectrum analyzer is 1MHz and video bandwidth is 3MHz for Peak detection at frequency above 1GHz.
5. The resolution bandwidth of test receiver/spectrum analyzer is 1MHz and video bandwidth is 10Hz for Average detection at frequency above 1GHz.
6. The other emissions is too low to be measured.



Power	: AC 120V	Pol/Phase	: HORIZONTAL
Test Mode 1	: Transmit / Receive	Temperature	: 26 °C
Operation Channel	: 1	Humidity	: 58 %
Modulation Type	: 802.11b	Atmospheric Pressure	: 1023 hPa
Memo	: Adapter:FA-1201500SUA	Rate	: 11 Mbps

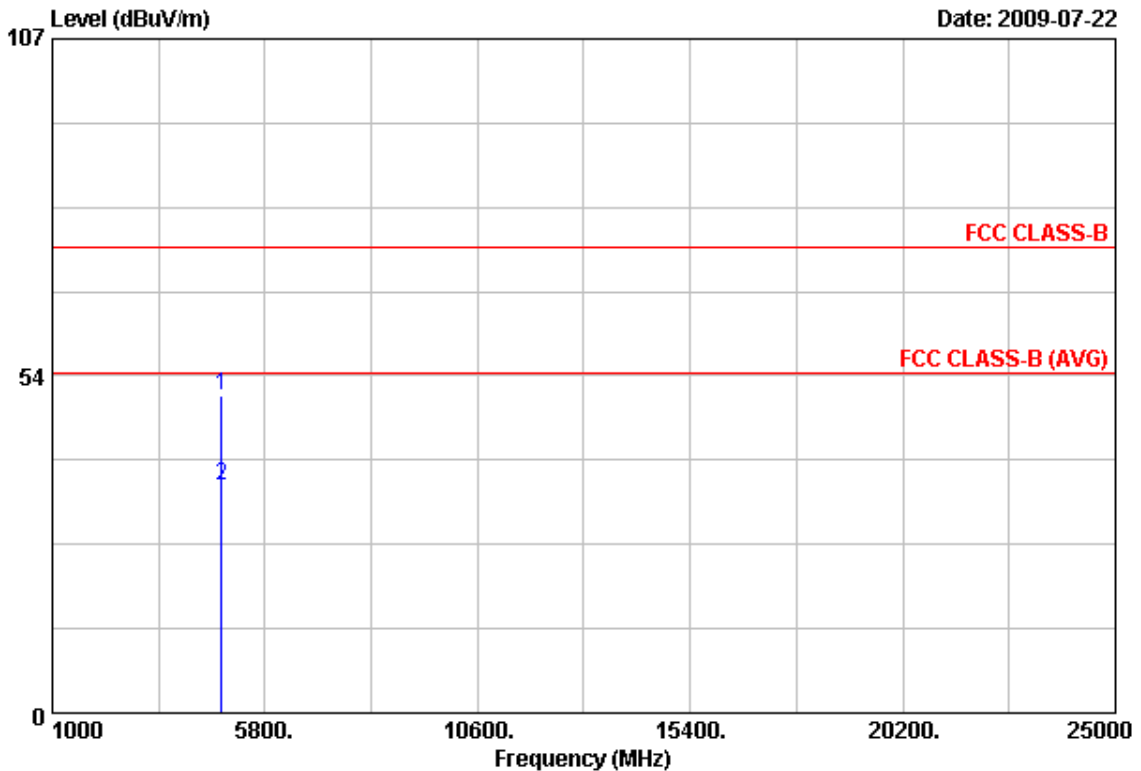

Item	Freq	Read Value	Factor	Result	Limit	Margin	Remark	Ant Pos	Tab Pos
	MHz	dBuV/m	dB	dBuV/m	dBuV/m	dB		cm	Deg
1	4822.85	45.00	5.33	50.33	74.00	-23.67	Peak	100	0
2	4823.35	30.82	5.33	36.15	54.00	-17.85	Average	100	0

Notes:

1. Result = Read Value + Factor
2. Factor = Antenna Factor + Cable Loss - Amplifier
3. The resolution bandwidth of test receiver/spectrum analyzer is 120KHz and video bandwidth is 300kHz for Peak detection and Quasi-peak detection at frequency below 1GHz.
4. The resolution bandwidth of test receiver/spectrum analyzer is 1MHz and video bandwidth is 3MHz for Peak detection at frequency above 1GHz.
5. The resolution bandwidth of test receiver/spectrum analyzer is 1MHz and video bandwidth is 10Hz for Average detection at frequency above 1GHz.
6. The other emissions is too low to be measured.



Power	: AC 120V	Pol/Phase	: VERTICAL
Test Mode 1	: Transmit / Receive	Temperature	: 26 °C
Operation Channel	: 6	Humidity	: 58 %
Modulation Type	: 802.11b	Atmospheric Pressure	: 1023 hPa
Memo	: Adapter:FA-1201500SUA	Rate	: 11 Mbps

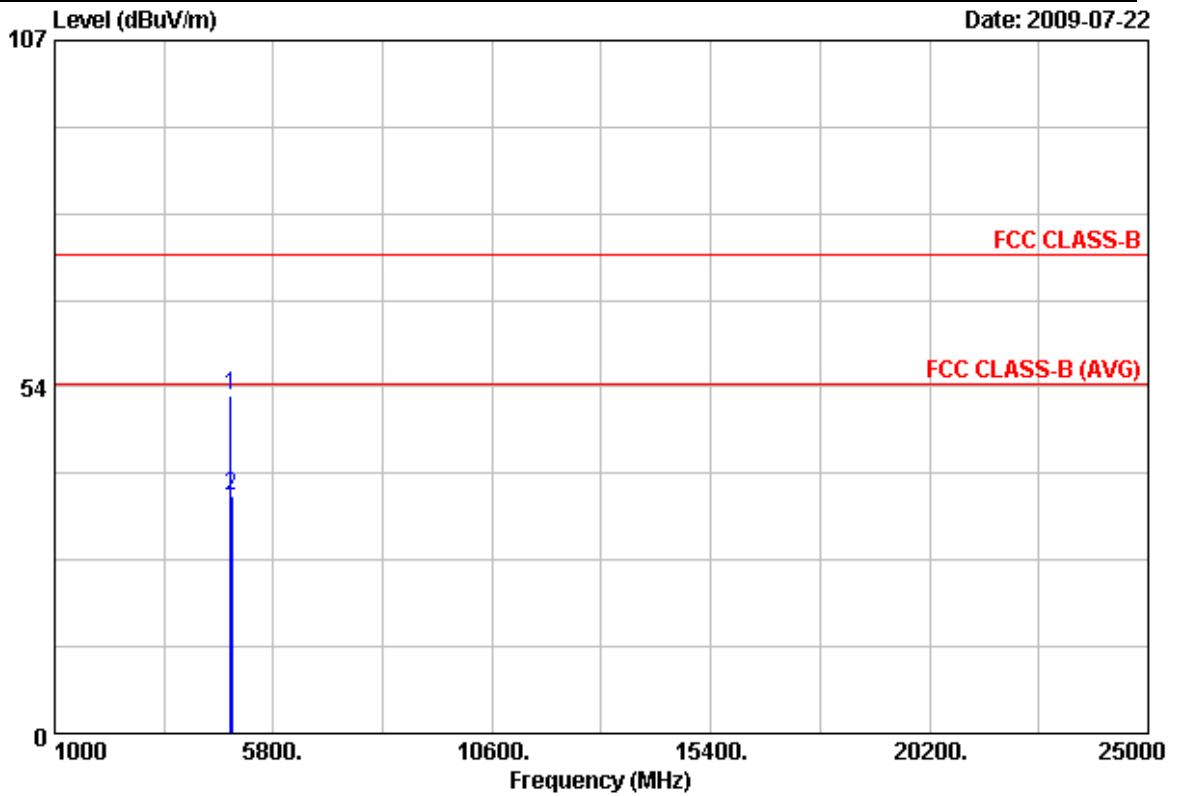

Item	Freq	Read Value	Factor	Result	Limit	Margin	Remark	Ant Pos	Tab Pos
	MHz	dBuV/m	dB	dBuV/m	dBuV/m	dB		cm	Deg
1	4870.10	46.72	5.48	52.20	74.00	-21.80	Peak	100	360
2	4873.25	31.17	5.49	36.66	54.00	-17.34	Average	100	360

Notes:

1. Result = Read Value + Factor
2. Factor = Antenna Factor + Cable Loss - Amplifier
3. The resolution bandwidth of test receiver/spectrum analyzer is 120KHz and video bandwidth is 300kHz for Peak detection and Quasi-peak detection at frequency below 1GHz.
4. The resolution bandwidth of test receiver/spectrum analyzer is 1MHz and video bandwidth is 3MHz for Peak detection at frequency above 1GHz.
5. The resolution bandwidth of test receiver/spectrum analyzer is 1MHz and video bandwidth is 10Hz for Average detection at frequency above 1GHz.
6. The other emissions is too low to be measured.



Power	: AC 120V	Pol/Phase	: HORIZONTAL
Test Mode 1	: Transmit / Receive	Temperature	: 26 °C
Operation Channel	: 6	Humidity	: 58 %
Modulation Type	: 802.11b	Atmospheric Pressure	: 1023 hPa
Memo	: Adapter:FA-1201500SUA	Rate	: 11 Mbps

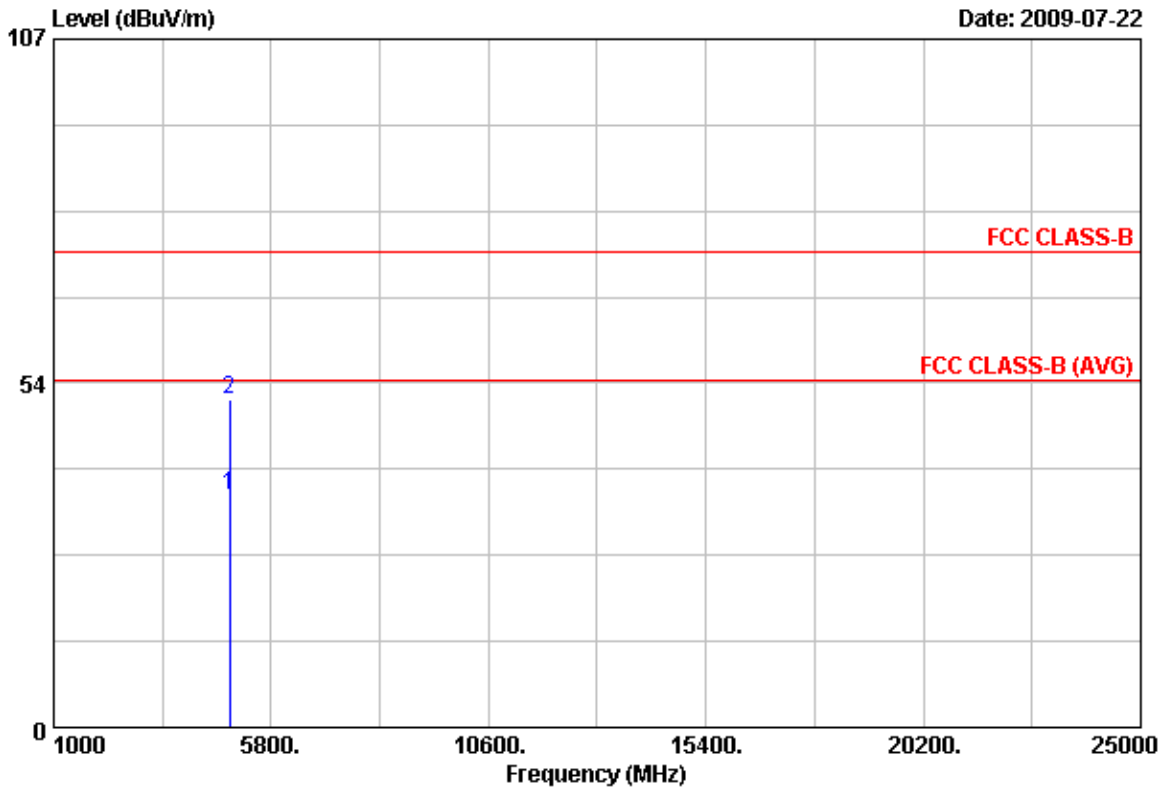

Item	Freq	Read Value	Factor	Result	Limit	Margin	Remark	Ant Pos	Tab Pos
	MHz	dBuV/m	dB	dBuV/m	dBuV/m	dB		cm	Deg
1	4873.30	30.66	5.49	36.15	54.00	-17.85	Average	100	0
2	4874.60	45.50	5.49	50.99	74.00	-23.01	Peak	100	0

Notes:

1. Result = Read Value + Factor
2. Factor = Antenna Factor + Cable Loss - Amplifier
3. The resolution bandwidth of test receiver/spectrum analyzer is 120KHz and video bandwidth is 300KHz for Peak detection and Quasi-peak detection at frequency below 1GHz.
4. The resolution bandwidth of test receiver/spectrum analyzer is 1MHz and video bandwidth is 3MHz for Peak detection at frequency above 1GHz.
5. The resolution bandwidth of test receiver/spectrum analyzer is 1MHz and video bandwidth is 10Hz for Average detection at frequency above 1GHz.
6. The other emissions is too low to be measured.



Power	: AC 120V	Pol/Phase	: VERTICAL
Test Mode 1	: Transmit / Receive	Temperature	: 26 °C
Operation Channel	: 11	Humidity	: 58 %
Modulation Type	: 802.11b	Atmospheric Pressure	: 1023 hPa
Memo	: Adapter:FA-1201500SUA	Rate	: 11 Mbps

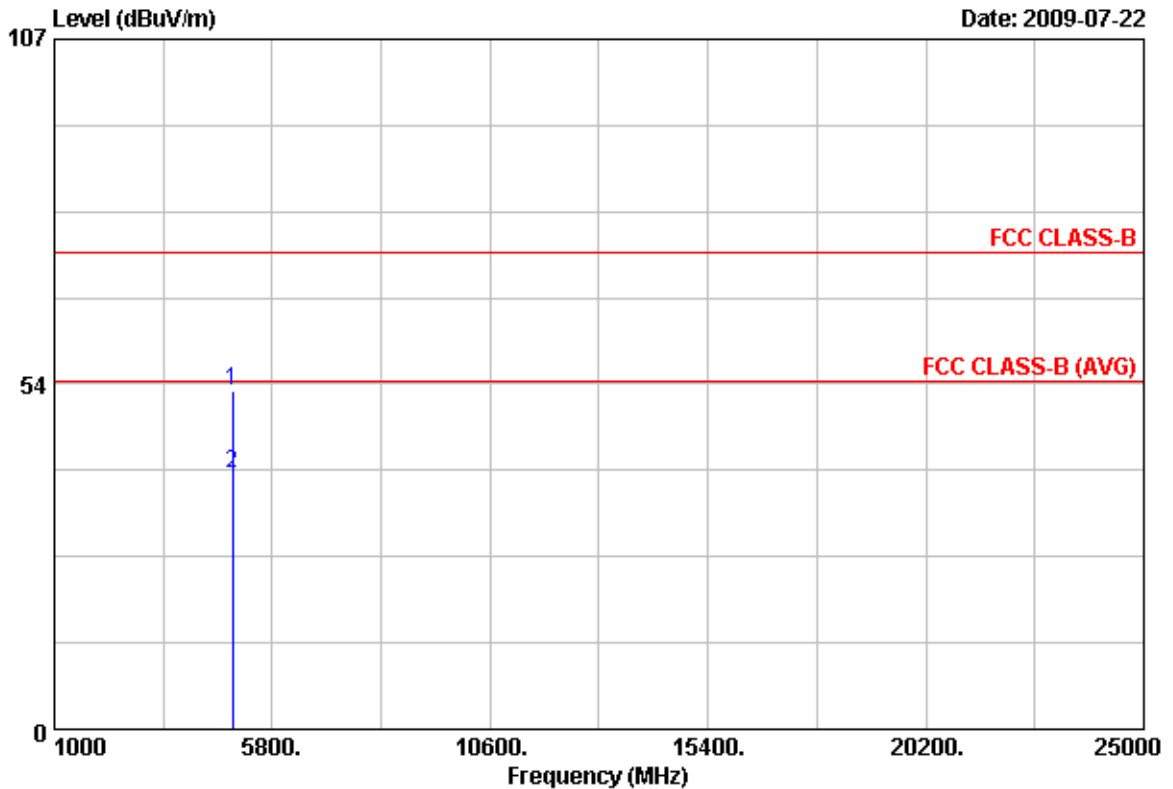

Item	Freq	Read Value	Factor	Result	Limit	Margin	Remark	Ant Pos	Tab Pos
	MHz	dBuV/m	dB	dBuV/m	dBuV/m	dB		cm	Deg
1	4921.90	46.68	5.65	52.33	74.00	-21.67	Peak	100	360
2	4922.50	34.01	5.65	39.66	54.00	-14.34	Average	100	360

Notes:

1. Result = Read Value + Factor
2. Factor = Antenna Factor + Cable Loss - Amplifier
3. The resolution bandwidth of test receiver/spectrum analyzer is 120KHz and video bandwidth is 300kHz for Peak detection and Quasi-peak detection at frequency below 1GHz.
4. The resolution bandwidth of test receiver/spectrum analyzer is 1MHz and video bandwidth is 3MHz for Peak detection at frequency above 1GHz.
5. The resolution bandwidth of test receiver/spectrum analyzer is 1MHz and video bandwidth is 10Hz for Average detection at frequency above 1GHz.
6. The other emissions is too low to be measured.



Power	: AC 120V	Pol/Phase	: HORIZONTAL
Test Mode 1	: Transmit / Receive	Temperature	: 26 °C
Operation Channel	: 11	Humidity	: 58 %
Modulation Type	: 802.11b	Atmospheric Pressure	: 1023 hPa
Memo	: Adapter:FA-1201500SUA	Rate	: 11 Mbps

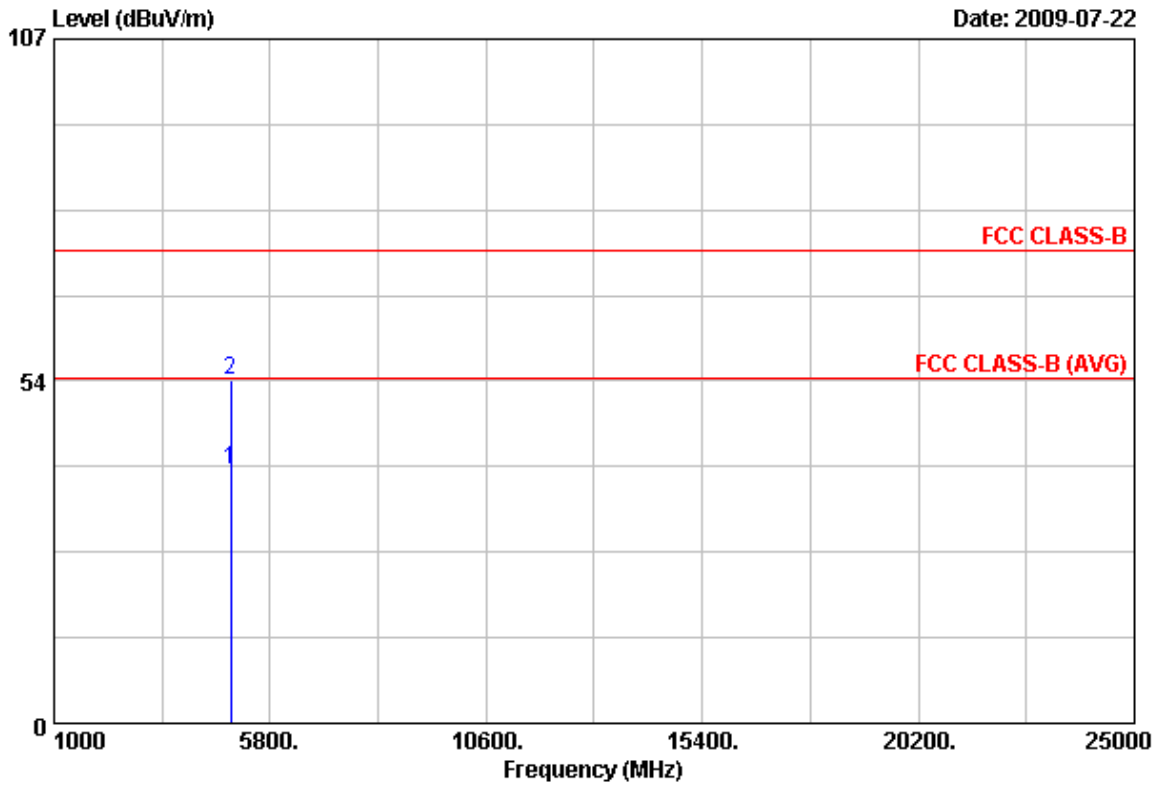

Item	Freq	Read Value	Factor	Result	Limit	Margin	Remark	Ant Pos	Tab Pos
	MHz	dBuV/m	dB	dBuV/m	dBuV/m	dB		cm	Deg
1	4923.20	33.86	5.65	39.51	54.00	-14.49	Average	100	0
2	4923.20	47.98	5.65	53.63	74.00	-20.37	Peak	100	0

Notes:

1. Result = Read Value + Factor
2. Factor = Antenna Factor + Cable Loss - Amplifier
3. The resolution bandwidth of test receiver/spectrum analyzer is 120KHz and video bandwidth is 300kHz for Peak detection and Quasi-peak detection at frequency below 1GHz.
4. The resolution bandwidth of test receiver/spectrum analyzer is 1MHz and video bandwidth is 3MHz for Peak detection at frequency above 1GHz.
5. The resolution bandwidth of test receiver/spectrum analyzer is 1MHz and video bandwidth is 10Hz for Average detection at frequency above 1GHz.
6. The other emissions is too low to be measured.



Power	: AC 120V	Pol/Phase	: VERTICAL
Test Mode 1	: Transmit / Receive	Temperature	: 26 °C
Operation Channel	: 1	Humidity	: 58 %
Modulation Type	: 802.11g	Atmospheric Pressure	: 1023 hPa
Memo	: Adapter:FA-1201500SUA	Rate	: 6 Mbps

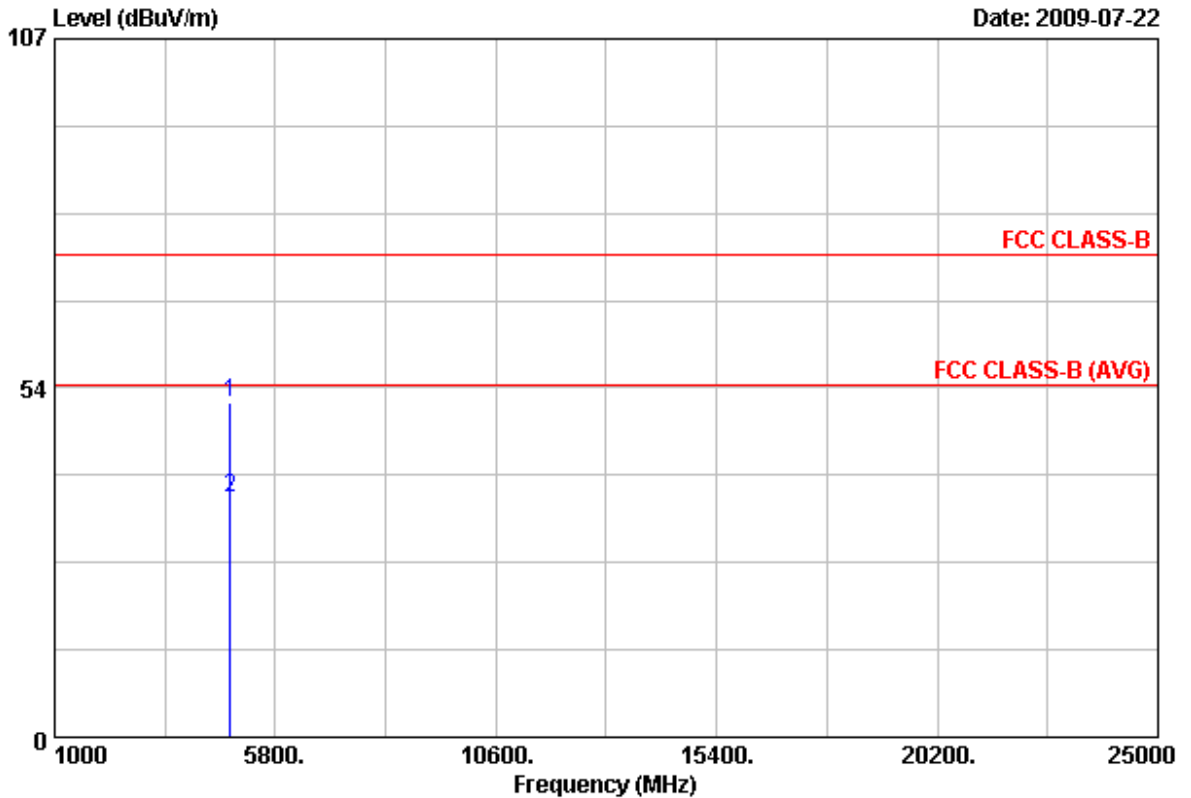

Item	Freq	Read Value	Factor	Result	Limit	Margin	Remark	Ant Pos	Tab Pos
	MHz	dBuV/m	dB	dBuV/m	dBuV/m	dB		cm	Deg
1	4822.90	45.94	5.33	51.27	74.00	-22.73	Peak	100	360
2	4824.70	31.32	5.33	36.65	54.00	-17.35	Average	100	360

Notes:

1. Result = Read Value + Factor
2. Factor = Antenna Factor + Cable Loss - Amplifier
3. The resolution bandwidth of test receiver/spectrum analyzer is 120KHz and video bandwidth is 300kHz for Peak detection and Quasi-peak detection at frequency below 1GHz.
4. The resolution bandwidth of test receiver/spectrum analyzer is 1MHz and video bandwidth is 3MHz for Peak detection at frequency above 1GHz.
5. The resolution bandwidth of test receiver/spectrum analyzer is 1MHz and video bandwidth is 10Hz for Average detection at frequency above 1GHz.
6. The other emissions is too low to be measured.



Power	: AC 120V	Pol/Phase	: HORIZONTAL
Test Mode 1	: Transmit / Receive	Temperature	: 26 °C
Operation Channel	: 1	Humidity	: 58 %
Modulation Type	: 802.11g	Atmospheric Pressure	: 1023 hPa
Memo	: Adapter:FA-1201500SUA	Rate	: 6 Mbps

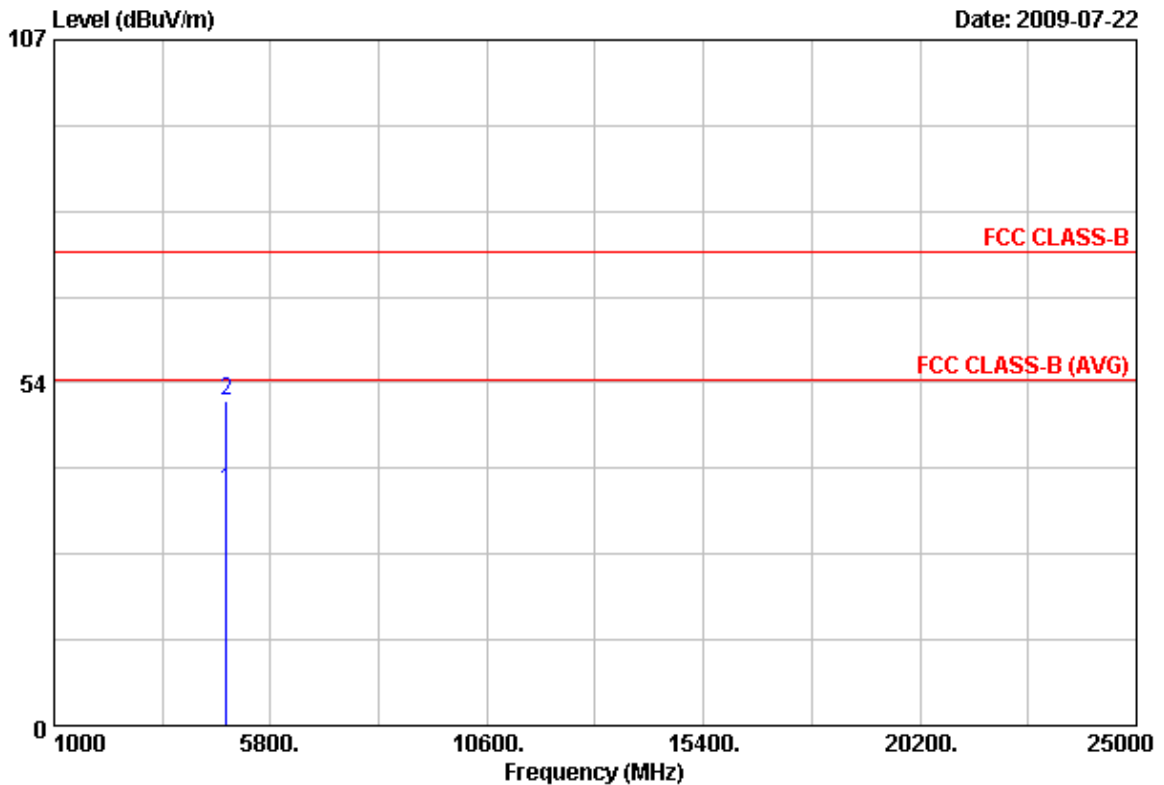

Item	Freq	Read Value	Factor	Result	Limit	Margin	Remark	Ant Pos	Tab Pos
	MHz	dBuV/m	dB	dBuV/m	dBuV/m	dB		cm	Deg
1	4823.70	31.30	5.33	36.63	54.00	-17.37	Average	100	0
2	4824.75	45.33	5.33	50.66	74.00	-23.34	Peak	100	0

Notes:

1. Result = Read Value + Factor
2. Factor = Antenna Factor + Cable Loss - Amplifier
3. The resolution bandwidth of test receiver/spectrum analyzer is 120KHz and video bandwidth is 300kHz for Peak detection and Quasi-peak detection at frequency below 1GHz.
4. The resolution bandwidth of test receiver/spectrum analyzer is 1MHz and video bandwidth is 3MHz for Peak detection at frequency above 1GHz.
5. The resolution bandwidth of test receiver/spectrum analyzer is 1MHz and video bandwidth is 10Hz for Average detection at frequency above 1GHz.
6. The other emissions is too low to be measured.





Power	: AC 120V	Pol/Phase	: VERTICAL
Test Mode 1	: Transmit / Receive	Temperature	: 26 °C
Operation Channel	: 6	Humidity	: 58 %
Modulation Type	: 802.11g	Atmospheric Pressure	: 1023 hPa
Memo	: Adapter:FA-1201500SUA	Rate	: 6 Mbps

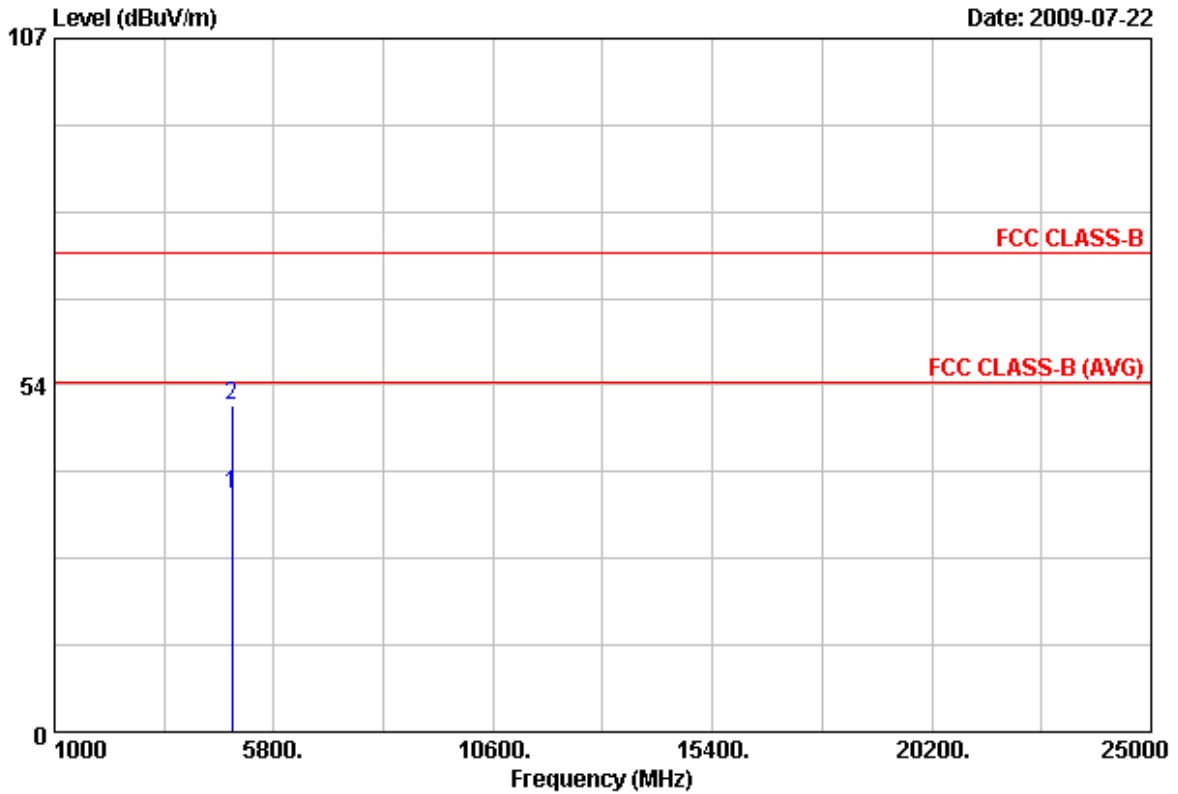

Item	Freq	Read Value	Factor	Result	Limit	Margin	Remark	Ant Pos	Tab Pos
	MHz	dBuV/m	dB	dBuV/m	dBuV/m	dB		cm	Deg
1	4873.65	31.16	5.49	36.65	54.00	-17.35	Average	100	325
2	4876.95	44.75	5.51	50.26	74.00	-23.74	Peak	100	205

Notes:

1. Result = Read Value + Factor
2. Factor = Antenna Factor + Cable Loss - Amplifier
3. The resolution bandwidth of test receiver/spectrum analyzer is 120KHz and video bandwidth is 300kHz for Peak detection and Quasi-peak detection at frequency below 1GHz.
4. The resolution bandwidth of test receiver/spectrum analyzer is 1MHz and video bandwidth is 3MHz for Peak detection at frequency above 1GHz.
5. The resolution bandwidth of test receiver/spectrum analyzer is 1MHz and video bandwidth is 10Hz for Average detection at frequency above 1GHz.
6. The other emissions is too low to be measured.



Power	: AC 120V	Pol/Phase	: HORIZONTAL
Test Mode 1	: Transmit / Receive	Temperature	: 26 °C
Operation Channel	: 6	Humidity	: 58 %
Modulation Type	: 802.11g	Atmospheric Pressure	: 1023 hPa
Memo	: Adapter:FA-1201500SUA	Rate	: 6 Mbps

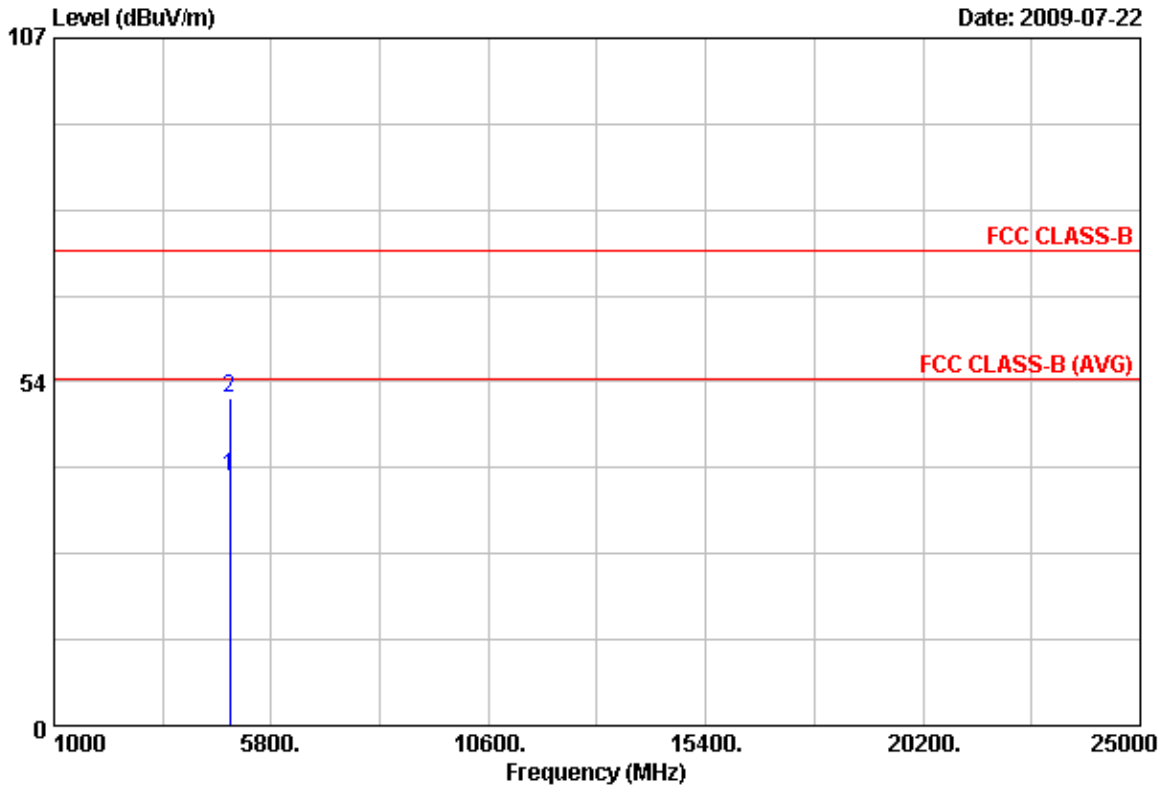

Item	Freq	Read Value	Factor	Result	Limit	Margin	Remark	Ant Pos	Tab Pos
	MHz	dBuV/m	dB	dBuV/m	dBuV/m	dB		cm	Deg
1	4873.40	33.16	5.49	38.65	54.00	-15.35	Average	100	0
2	4874.55	45.37	5.49	50.86	74.00	-23.14	Peak	100	0

Notes:

1. Result = Read Value + Factor
2. Factor = Antenna Factor + Cable Loss - Amplifier
3. The resolution bandwidth of test receiver/spectrum analyzer is 120KHz and video bandwidth is 300kHz for Peak detection and Quasi-peak detection at frequency below 1GHz.
4. The resolution bandwidth of test receiver/spectrum analyzer is 1MHz and video bandwidth is 3MHz for Peak detection at frequency above 1GHz.
5. The resolution bandwidth of test receiver/spectrum analyzer is 1MHz and video bandwidth is 10Hz for Average detection at frequency above 1GHz.
6. The other emissions is too low to be measured.



Power	: AC 120V	Pol/Phase	: VERTICAL
Test Mode 1	: Transmit / Receive	Temperature	: 26 °C
Operation Channel	: 11	Humidity	: 58 %
Modulation Type	: 802.11g	Atmospheric Pressure	: 1023 hPa
Memo	: Adapter:FA-1201500SUA	Rate	: 6 Mbps

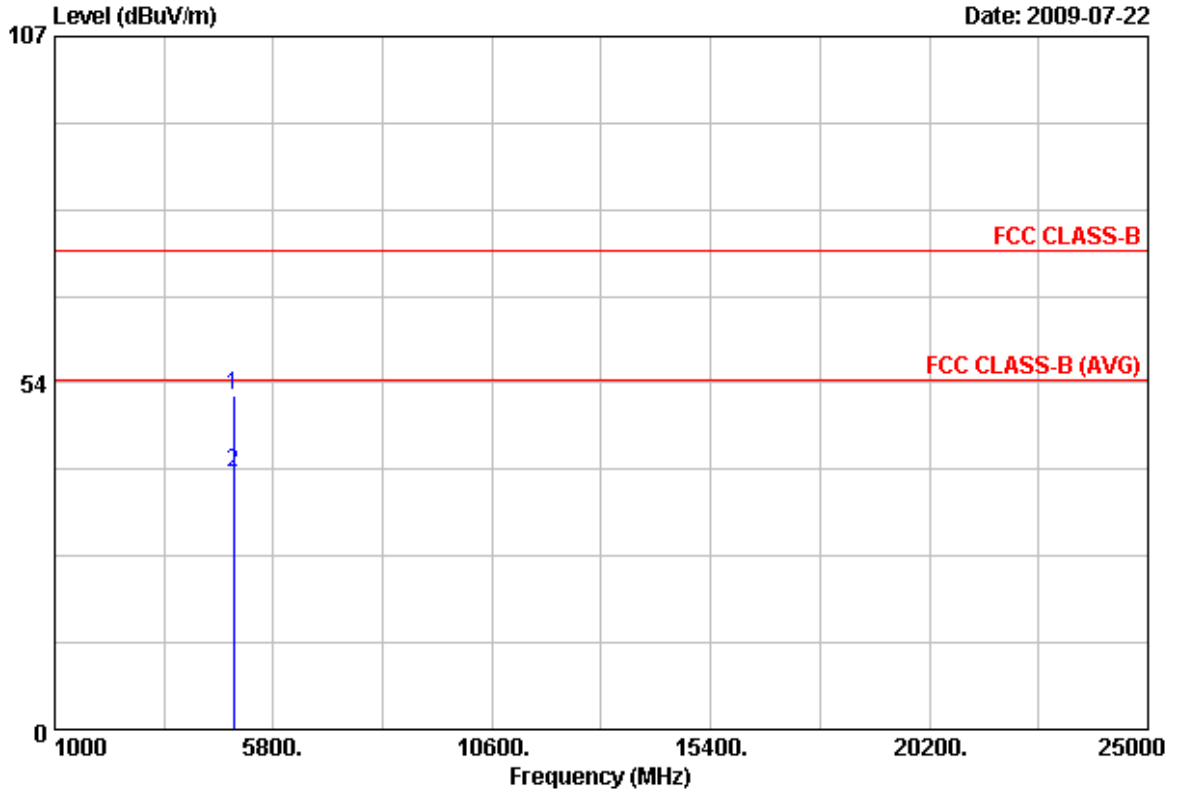

Item	Freq	Read Value	Factor	Result	Limit	Margin	Remark	Ant Pos	Tab Pos
	MHz	dBuV/m	dB	dBuV/m	dBuV/m	dB		cm	Deg
1	4923.25	45.86	5.65	51.51	74.00	-22.49	Peak	100	360
2	4925.75	33.98	5.67	39.65	54.00	-14.35	Average	100	360

Notes:

1. Result = Read Value + Factor
2. Factor = Antenna Factor + Cable Loss - Amplifier
3. The resolution bandwidth of test receiver/spectrum analyzer is 120KHz and video bandwidth is 300kHz for Peak detection and Quasi-peak detection at frequency below 1GHz.
4. The resolution bandwidth of test receiver/spectrum analyzer is 1MHz and video bandwidth is 3MHz for Peak detection at frequency above 1GHz.
5. The resolution bandwidth of test receiver/spectrum analyzer is 1MHz and video bandwidth is 10Hz for Average detection at frequency above 1GHz.
6. The other emissions is too low to be measured.



Power	: AC 120V	Pol/Phase	: HORIZONTAL
Test Mode 1	: Transmit / Receive	Temperature	: 26 °C
Operation Channel	: 11	Humidity	: 58 %
Modulation Type	: 802.11g	Atmospheric Pressure	: 1023 hPa
Memo	: Adapter:FA-1201500SUA	Rate	: 6 Mbps

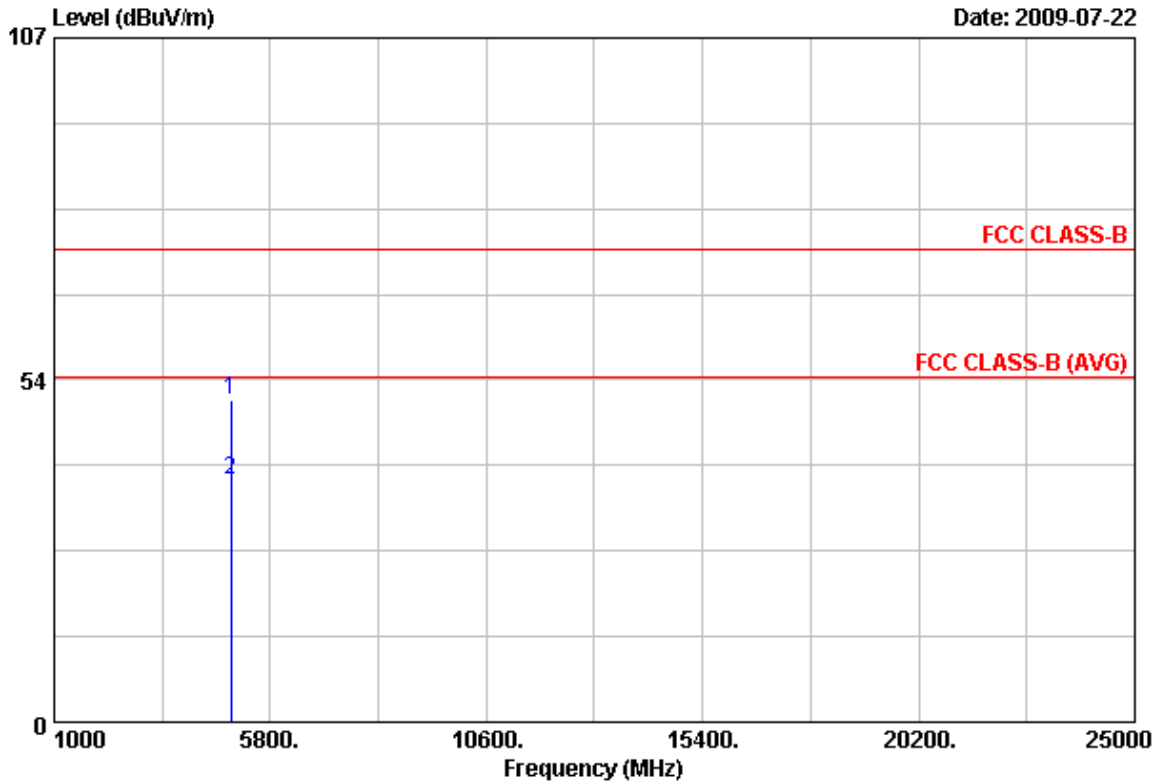

Item	Freq	Read Value	Factor	Result	Limit	Margin	Remark	Ant Pos	Tab Pos
	MHz	dBuV/m	dB	dBuV/m	dBuV/m	dB		cm	Deg
1	4922.95	44.58	5.65	50.23	74.00	-23.77	Peak	100	0
2	4925.10	32.18	5.67	37.85	54.00	-16.15	Average	100	0

Notes:

1. Result = Read Value + Factor
2. Factor = Antenna Factor + Cable Loss - Amplifier
3. The resolution bandwidth of test receiver/spectrum analyzer is 120KHz and video bandwidth is 300kHz for Peak detection and Quasi-peak detection at frequency below 1GHz.
4. The resolution bandwidth of test receiver/spectrum analyzer is 1MHz and video bandwidth is 3MHz for Peak detection at frequency above 1GHz.
5. The resolution bandwidth of test receiver/spectrum analyzer is 1MHz and video bandwidth is 10Hz for Average detection at frequency above 1GHz.
6. The other emissions is too low to be measured.



Power	: AC 120V	Pol/Phase	: VERTICAL
Test Mode 1	: Transmit / Receive	Temperature	: 26 °C
Operation Channel	: 1	Humidity	: 58 %
Modulation Type	: 802.11n, HT20	Atmospheric Pressure	: 1023 hPa
Memo	: Adapter: FA-1201500SUA	Rate	: 6.5 Mbps

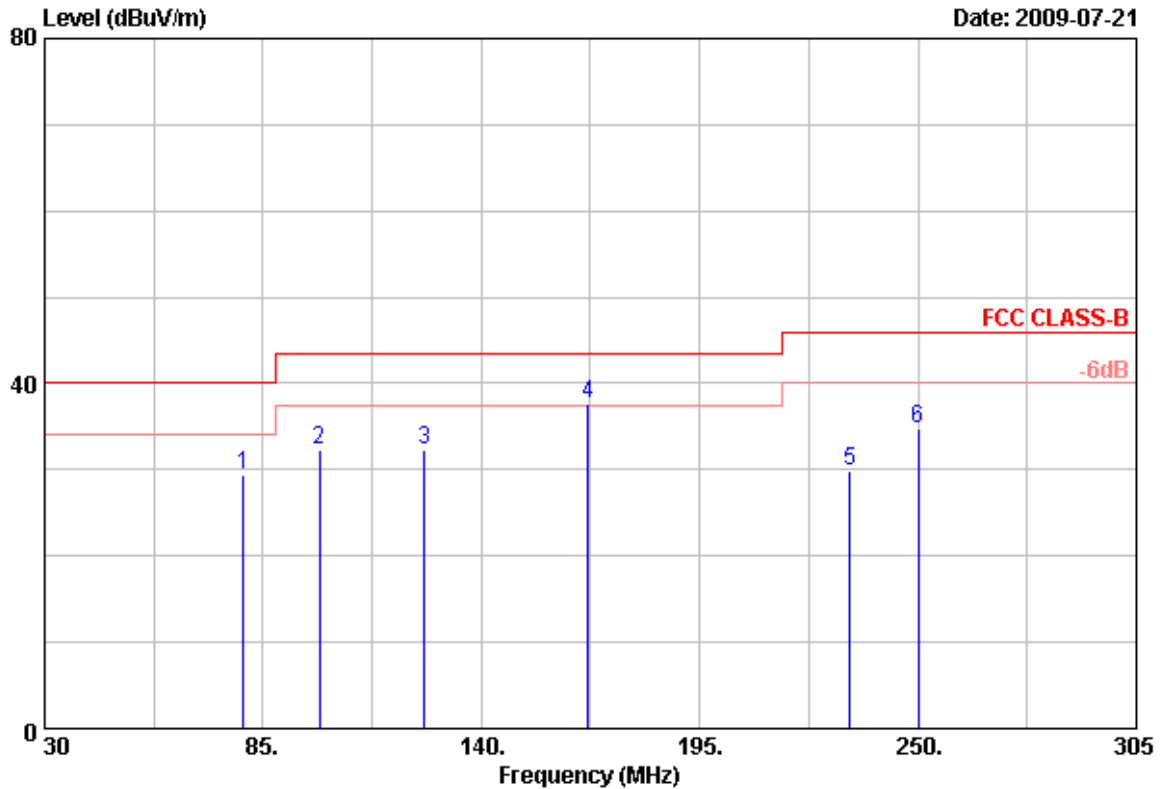

Item	Freq	Read Value	Factor	Result	Limit	Margin	Remark	Ant Pos	Tab Pos
	MHz	dBuV/m	dB	dBuV/m	dBuV/m	dB		cm	Deg
1	80.05	43.74	-14.36	29.38	40.00	-10.62	Peak	100	360
2	99.30	43.99	-11.72	32.27	43.50	-11.23	Peak	100	360
3	125.70	41.59	-9.31	32.28	43.50	-11.22	Peak	100	360
4	166.95	49.79	-12.12	37.67	43.50	-5.83	QP	100	360
5	232.95	41.41	-11.65	29.76	46.00	-16.24	Peak	100	360
6	250.00	47.30	-12.64	34.66	46.00	-11.34	Peak	100	360

Notes:

1. Result = Read Value + Factor
2. Factor = Antenna Factor + Cable Loss - Amplifier
3. The resolution bandwidth of test receiver/spectrum analyzer is 120KHz and video bandwidth is 300kHz for Peak detection and Quasi-peak detection at frequency below 1GHz.
4. According to technical experiences, all spurious emission of 802.11MIMO mode at channel 1,6,11 are almost the same below 1GHz, so that the channel 1 was chosen as representative in final test.
5. The data is worse case.



Power	: AC 120V	Pol/Phase	: VERTICAL
Test Mode 1	: Transmit / Receive	Temperature	: 26 °C
Operation Channel	: 1	Humidity	: 58 %
Modulation Type	: 802.11n, HT20	Atmospheric Pressure	: 1023 hPa
Memo	: Adapter: FA-1201500SUA	Rate	: 6.5 Mbps

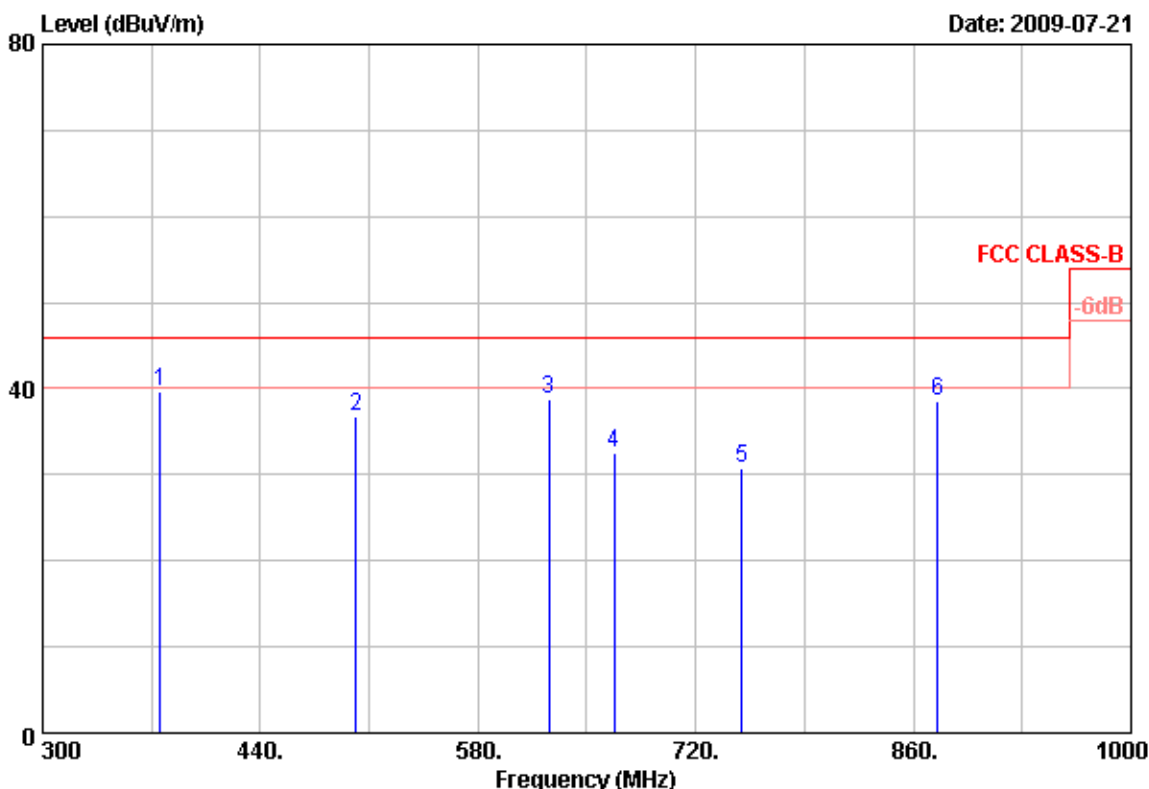

Item	Freq	Read Value	Factor	Result	Limit	Margin	Remark	Ant Pos	Tab Pos
	MHz	dBuV/m	dB	dBuV/m	dBuV/m	dB		cm	Deg
1	375.60	49.89	-10.31	39.58	46.00	-6.42	Peak	100	0
2	501.60	45.23	-8.44	36.79	46.00	-9.21	Peak	100	0
3	625.50	45.19	-6.52	38.67	46.00	-7.33	Peak	100	0
4	667.50	36.47	-3.94	32.53	46.00	-13.47	Peak	100	0
5	749.40	31.68	-0.91	30.77	46.00	-15.23	Peak	100	0
6	875.40	37.78	0.75	38.53	46.00	-7.47	Peak	100	0

Notes:

1. Result = Read Value + Factor
2. Factor = Antenna Factor + Cable Loss - Amplifier
3. The resolution bandwidth of test receiver/spectrum analyzer is 120KHz and video bandwidth is 300kHz for Peak detection and Quasi-peak detection at frequency below 1GHz.
4. According to technical experiences, all spurious emission of 802.11MIMO mode at channel 1,6,11 are almost the same below 1GHz, so that the channel 1 was chosen as representative in final test.
5. The data is worse case.



Power	: AC 120V	Pol/Phase	: HORIZONTAL
Test Mode 1	: Transmit / Receive	Temperature	: 26 °C
Operation Channel	: 1	Humidity	: 58 %
Modulation Type	: 802.11n, HT20	Atmospheric Pressure	: 1023 hPa
Memo	: Adapter: FA-1201500SUA	Rate	: 6.5 Mbps

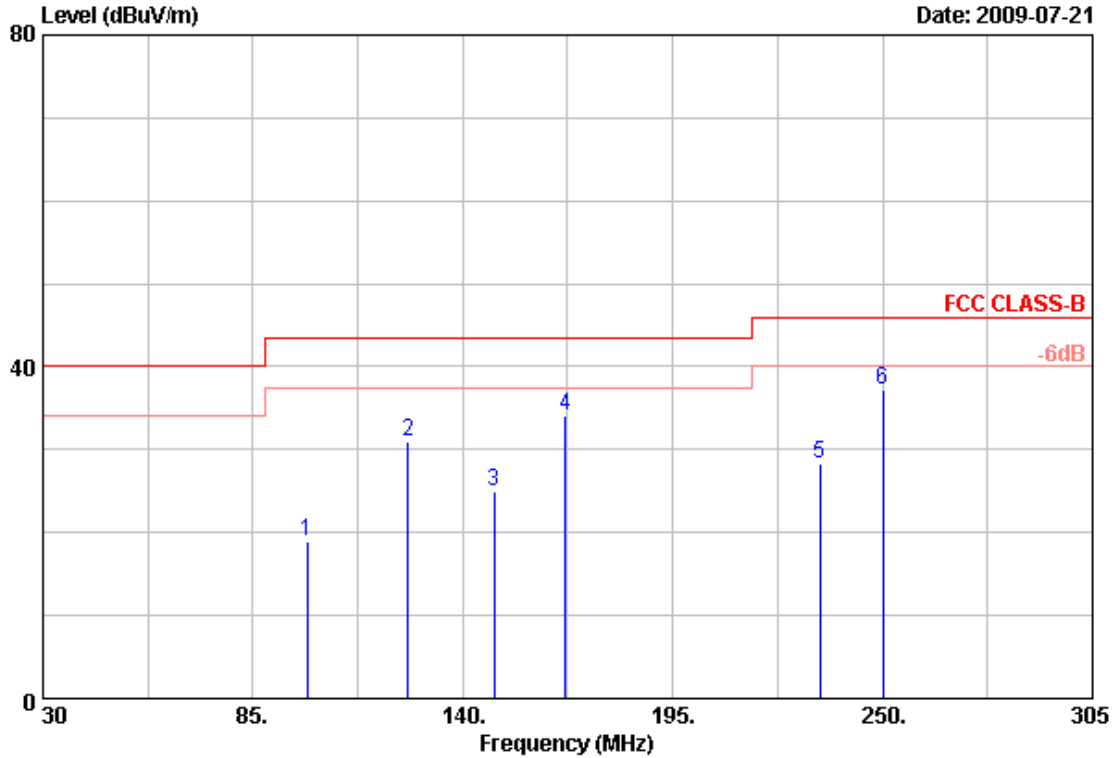

Item	Freq	Read Value	Factor	Result	Limit	Margin	Remark	Ant Pos	Tab Pos
	MHz	dBuV/m	dB	dBuV/m	dBuV/m	dB		cm	Deg
1	99.30	37.72	-18.88	18.84	43.50	-24.66	Peak	100	360
2	125.70	47.61	-16.64	30.97	43.50	-12.53	Peak	100	360
3	148.25	41.43	-16.43	25.00	43.50	-18.50	Peak	100	360
4	166.95	51.42	-17.25	34.17	43.50	-9.33	Peak	100	360
5	233.50	44.32	-16.10	28.22	46.00	-17.78	Peak	100	360
6	250.00	52.48	-15.28	37.20	46.00	-8.80	Peak	100	360

Notes:

1. Result = Read Value + Factor
2. Factor = Antenna Factor + Cable Loss - Amplifier
3. The resolution bandwidth of test receiver/spectrum analyzer is 120KHz and video bandwidth is 300kHz for Peak detection and Quasi-peak detection at frequency below 1GHz.
4. According to technical experiences, all spurious emission of 802.11MIMO mode at channel 1,6,11 are almost the same below 1GHz, so that the channel 1 was chosen as representative in final test.
5. The data is worse case.



Power	: AC 120V	Pol/Phase	: HORIZONTAL
Test Mode 1	: Transmit / Receive	Temperature	: 26 °C
Operation Channel	: 1	Humidity	: 58 %
Modulation Type	: 802.11n, HT20	Atmospheric Pressure	: 1023 hPa
Memo	: Adapter: FA-1201500SUA	Rate	: 6.5 Mbps

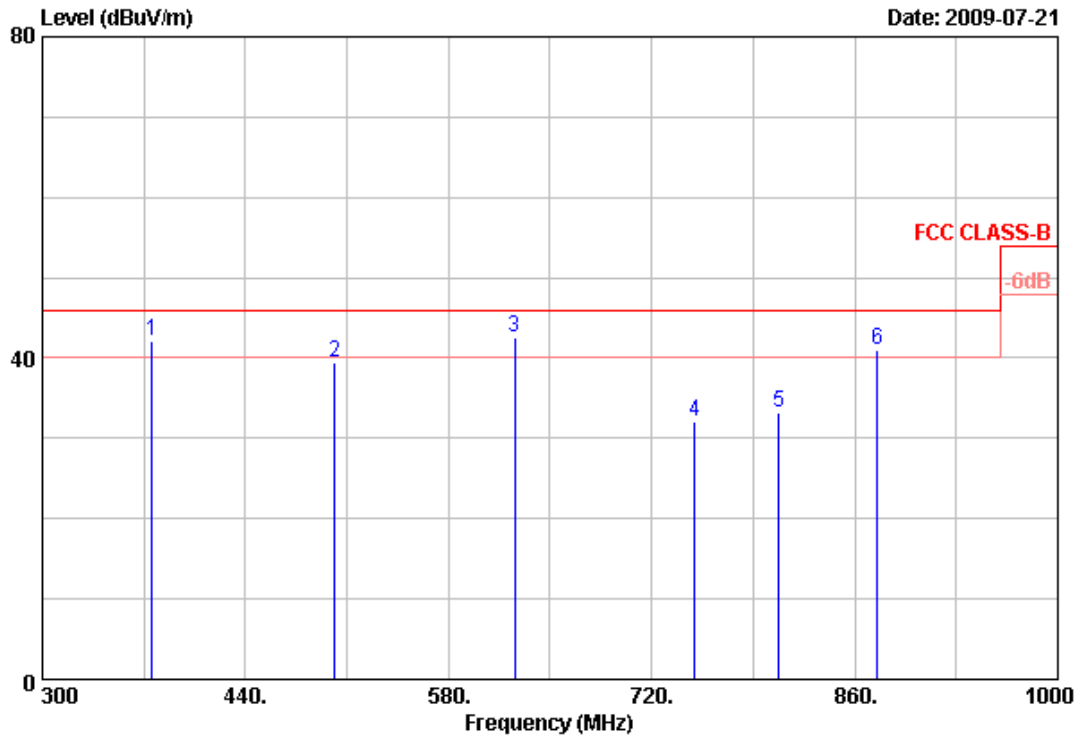

Item	Freq	Read Value	Factor	Result	Limit	Margin	Remark	Ant Pos	Tab Pos
	MHz	dBuV/m	dB	dBuV/m	dBuV/m	dB		cm	Deg
1	375.60	53.86	-11.68	42.18	46.00	-3.82	QP	100	0
2	501.60	44.90	-5.42	39.48	46.00	-6.52	Peak	100	0
3	625.50	44.04	-1.45	42.59	46.00	-3.41	QP	100	0
4	749.40	33.83	-1.85	31.98	46.00	-14.02	Peak	100	0
5	807.50	33.70	-0.51	33.19	46.00	-12.81	Peak	100	0
6	875.40	40.86	0.06	40.92	46.00	-5.08	QP	100	0

Notes:

1. Result = Read Value + Factor
2. Factor = Antenna Factor + Cable Loss - Amplifier
3. The resolution bandwidth of test receiver/spectrum analyzer is 120KHz and video bandwidth is 300kHz for Peak detection and Quasi-peak detection at frequency below 1GHz.
4. According to technical experiences, all spurious emission of 802.11MIMO mode at channel 1,6,11 are almost the same below 1GHz, so that the channel 1 was chosen as representative in final test.
5. The data is worse case.





Power	: AC 120V	Pol/Phase	: VERTICAL
Test Mode 1	: Transmit / Receive	Temperature	: 26 °C
Operation Channel	: 1	Humidity	: 58 %
Modulation Type	: 802.11n, HT20	Atmospheric Pressure	: 1023 hPa
Memo	: Adapter: FA-1201500SUA	Rate	: 6.5 Mbps

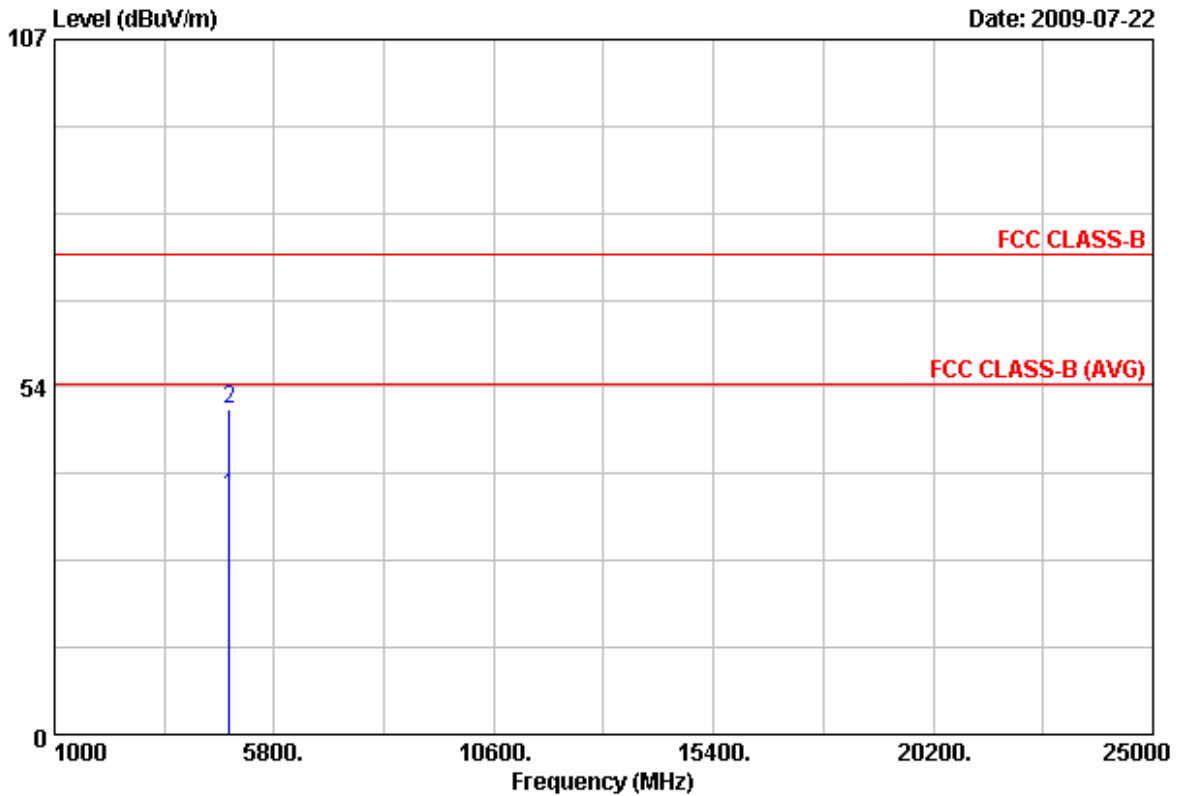

Item	Freq	Read Value	Factor	Result	Limit	Margin	Remark	Ant Pos	Tab Pos
	MHz	dBuV/m	dB	dBuV/m	dBuV/m	dB		cm	Deg
1	4823.65	31.33	5.33	36.66	54.00	-17.34	Average	100	0
2	4824.35	44.86	5.33	50.19	74.00	-23.81	Peak	100	0

Notes:

1. Result = Read Value + Factor
2. Factor = Antenna Factor + Cable Loss - Amplifier
3. The resolution bandwidth of test receiver/spectrum analyzer is 120KHz and video bandwidth is 300kHz for Peak detection and Quasi-peak detection at frequency below 1GHz.
4. The resolution bandwidth of test receiver/spectrum analyzer is 1MHz and video bandwidth is 3MHz for Peak detection at frequency above 1GHz.
5. The resolution bandwidth of test receiver/spectrum analyzer is 1MHz and video bandwidth is 10Hz for Average detection at frequency above 1GHz.
6. The other emissions is too low to be measured.



Power	: AC 120V	Pol/Phase	: HORIZONTAL
Test Mode 1	: Transmit / Receive	Temperature	: 26 °C
Operation Channel	: 1	Humidity	: 58 %
Modulation Type	: 802.11n, HT20	Atmospheric Pressure	: 1023 hPa
Memo	: Adapter: FA-1201500SUA	Rate	: 6.5 Mbps

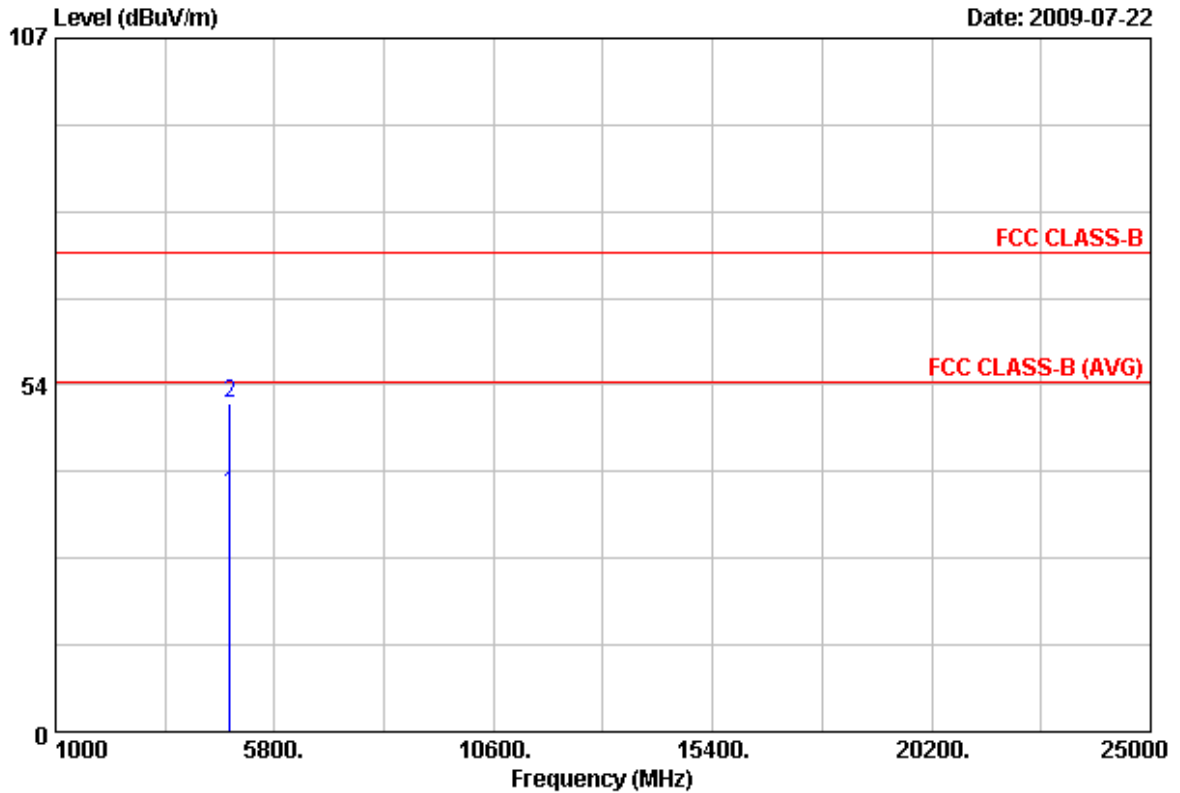

Item	Freq	Read Value	Factor	Result	Limit	Margin	Remark	Ant Pos	Tab Pos
	MHz	dBuV/m	dB	dBuV/m	dBuV/m	dB		cm	Deg
1	4823.60	31.30	5.33	36.63	54.00	-17.37	Average	100	0
2	4824.30	45.33	5.33	50.66	74.00	-23.34	Peak	100	0

Notes:

1. Result = Read Value + Factor
2. Factor = Antenna Factor + Cable Loss - Amplifier
3. The resolution bandwidth of test receiver/spectrum analyzer is 120kHz and video bandwidth is 300kHz for Peak detection and Quasi-peak detection at frequency below 1GHz.
4. The resolution bandwidth of test receiver/spectrum analyzer is 1MHz and video bandwidth is 3MHz for Peak detection at frequency above 1GHz.
5. The resolution bandwidth of test receiver/spectrum analyzer is 1MHz and video bandwidth is 10Hz for Average detection at frequency above 1GHz.
6. The other emissions is too low to be measured.



Power	: AC 120V	Pol/Phase	: VERTICAL
Test Mode 1	: Transmit / Receive	Temperature	: 26 °C
Operation Channel	: 6	Humidity	: 58 %
Modulation Type	: 802.11n, HT20	Atmospheric Pressure	: 1023 hPa
Memo	: Adapter: FA-1201500SUA	Rate	: 6.5 Mbps

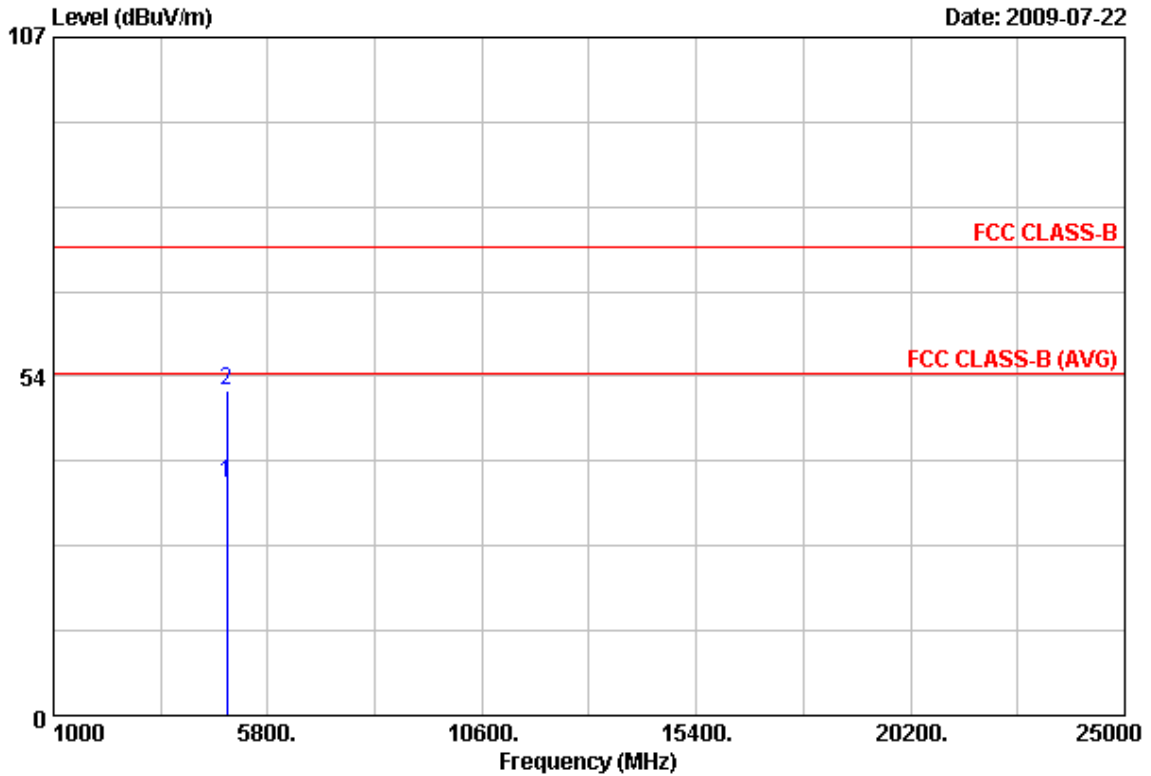

Item	Freq	Read Value	Factor	Result	Limit	Margin	Remark	Ant Pos	Tab Pos
	MHz	dBuV/m	dB	dBuV/m	dBuV/m	dB		cm	Deg
1	4873.05	31.17	5.49	36.66	54.00	-17.34	Average	100	0
2	4875.55	45.82	5.51	51.33	74.00	-22.67	Peak	100	0

Notes:

1. Result = Read Value + Factor
2. Factor = Antenna Factor + Cable Loss - Amplifier
3. The resolution bandwidth of test receiver/spectrum analyzer is 120KHz and video bandwidth is 300KHz for Peak detection and Quasi-peak detection at frequency below 1GHz.
4. The resolution bandwidth of test receiver/spectrum analyzer is 1MHz and video bandwidth is 3MHz for Peak detection at frequency above 1GHz.
5. The resolution bandwidth of test receiver/spectrum analyzer is 1MHz and video bandwidth is 10Hz for Average detection at frequency above 1GHz.
6. The other emissions is too low to be measured.



Power	: AC 120V	Pol/Phase	: HORIZONTAL
Test Mode 1	: Transmit / Receive	Temperature	: 26 °C
Operation Channel	: 6	Humidity	: 58 %
Modulation Type	: 802.11n, HT20	Atmospheric Pressure	: 1023 hPa
Memo	: Adapter: FA-1201500SUA	Rate	: 6.5 Mbps

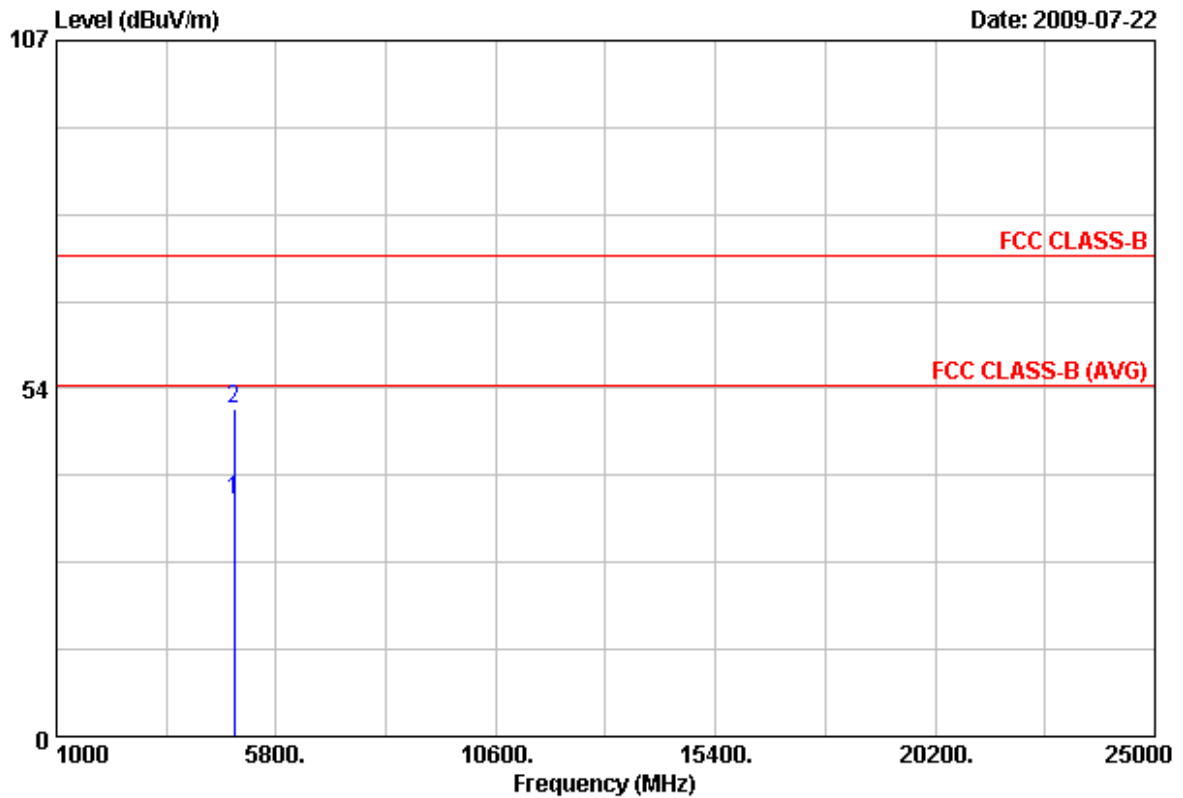

Item	Freq	Read Value	Factor	Result	Limit	Margin	Remark	Ant Pos	Tab Pos
	MHz	dBuV/m	dB	dBuV/m	dBuV/m	dB		cm	Deg
1	4873.40	30.97	5.49	36.46	54.00	-17.54	Average	100	0
2	4874.70	44.94	5.49	50.43	74.00	-23.57	Peak	100	0

Notes:

1. Result = Read Value + Factor
2. Factor = Antenna Factor + Cable Loss - Amplifier
3. The resolution bandwidth of test receiver/spectrum analyzer is 120KHz and video bandwidth is 300kHz for Peak detection and Quasi-peak detection at frequency below 1GHz.
4. The resolution bandwidth of test receiver/spectrum analyzer is 1MHz and video bandwidth is 3MHz for Peak detection at frequency above 1GHz.
5. The resolution bandwidth of test receiver/spectrum analyzer is 1MHz and video bandwidth is 10Hz for Average detection at frequency above 1GHz.
6. The other emissions is too low to be measured.



Power	: AC 120V	Pol/Phase	: VERTICAL
Test Mode 1	: Transmit / Receive	Temperature	: 26 °C
Operation Channel	: 11	Humidity	: 58 %
Modulation Type	: 802.11n, HT20	Atmospheric Pressure	: 1023 hPa
Memo	: Adapter: FA-1201500SUA	Rate	: 6.5 Mbps

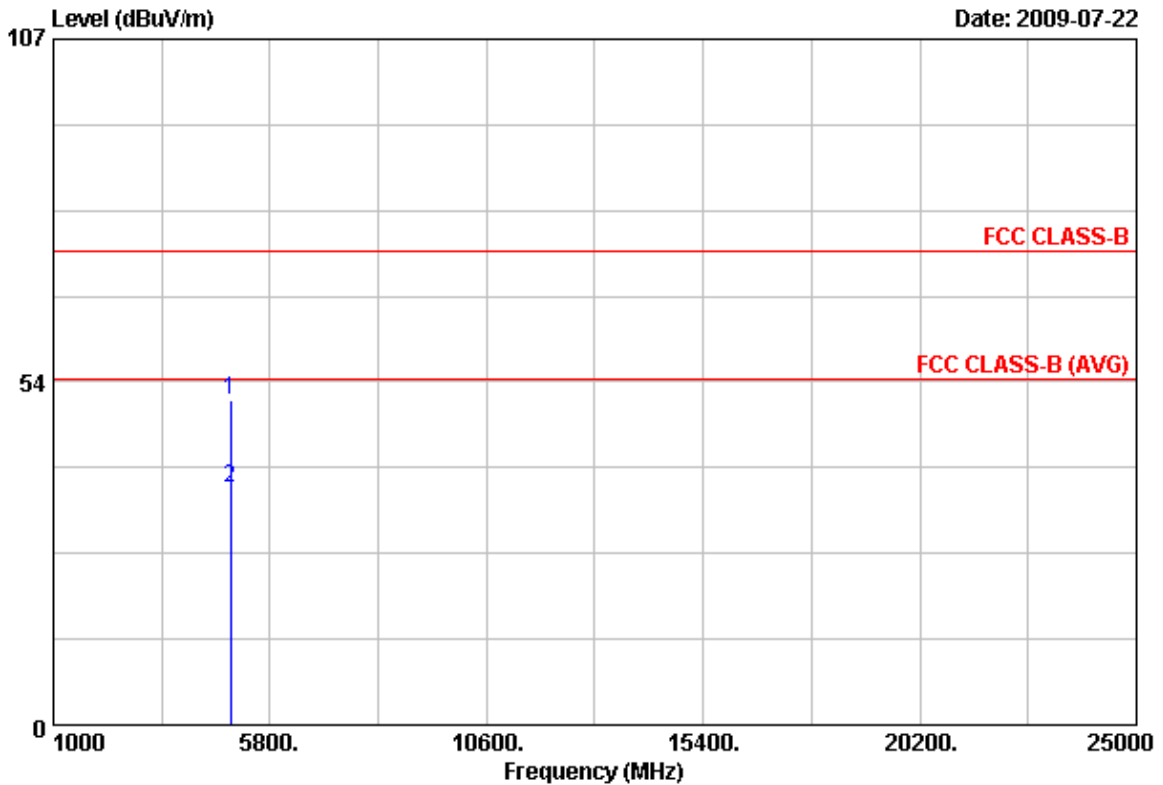

Item	Freq	Read Value	Factor	Result	Limit	Margin	Remark	Ant Pos	Tab Pos
	MHz	dBuV/m	dB	dBuV/m	dBuV/m	dB		cm	Deg
1	4920.80	45.01	5.64	50.65	74.00	-23.35	Peak	100	0
2	4924.90	31.20	5.65	36.85	54.00	-17.15	Average	100	0

Notes:

1. Result = Read Value + Factor
2. Factor = Antenna Factor + Cable Loss - Amplifier
3. The resolution bandwidth of test receiver/spectrum analyzer is 120KHz and video bandwidth is 300kHz for Peak detection and Quasi-peak detection at frequency below 1GHz.
4. The resolution bandwidth of test receiver/spectrum analyzer is 1MHz and video bandwidth is 3MHz for Peak detection at frequency above 1GHz.
5. The resolution bandwidth of test receiver/spectrum analyzer is 1MHz and video bandwidth is 10Hz for Average detection at frequency above 1GHz.
6. The other emissions is too low to be measured.



Power	: AC 120V	Pol/Phase	: HORIZONTAL
Test Mode 1	: Transmit / Receive	Temperature	: 26 °C
Operation Channel	: 11	Humidity	: 58 %
Modulation Type	: 802.11n, HT20	Atmospheric Pressure	: 1023 hPa
Memo	: Adapter: FA-1201500SUA	Rate	: 6.5 Mbps

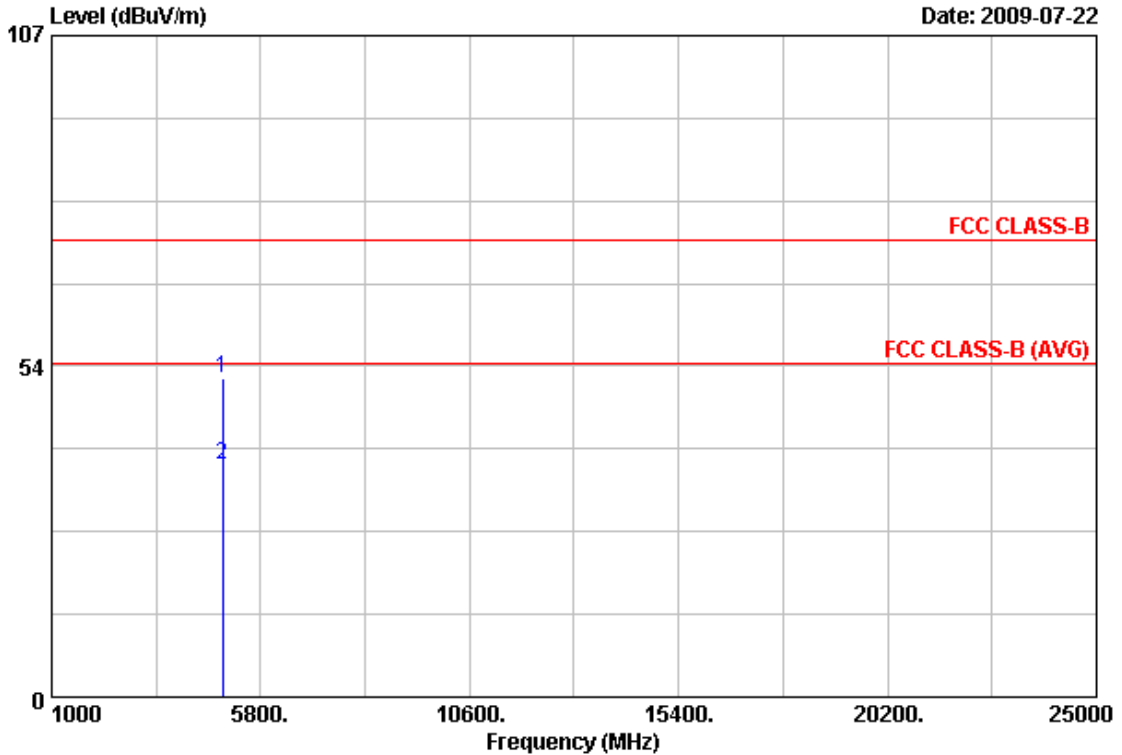

Item	Freq	Read Value	Factor	Result	Limit	Margin	Remark	Ant Pos	Tab Pos
	MHz	dBuV/m	dB	dBuV/m	dBuV/m	dB		cm	Deg
1	4923.00	45.98	5.65	51.63	74.00	-22.37	Peak	100	0
2	4923.40	32.01	5.65	37.66	54.00	-16.34	Average	100	0

Notes:

1. Result = Read Value + Factor
2. Factor = Antenna Factor + Cable Loss - Amplifier
3. The resolution bandwidth of test receiver/spectrum analyzer is 120KHz and video bandwidth is 300kHz for Peak detection and Quasi-peak detection at frequency below 1GHz.
4. The resolution bandwidth of test receiver/spectrum analyzer is 1MHz and video bandwidth is 3MHz for Peak detection at frequency above 1GHz.
5. The resolution bandwidth of test receiver/spectrum analyzer is 1MHz and video bandwidth is 10Hz for Average detection at frequency above 1GHz.
6. The other emissions is too low to be measured.



Power	: AC 120V	Pol/Phase	: VERTICAL
Test Mode 1	: Transmit / Receive	Temperature	: 26 °C
Operation Channel	: 3	Humidity	: 58 %
Modulation Type	: 802.11n, HT40	Atmospheric Pressure	: 1023 hPa
Memo	: Adapter: FA-1201500SUA	Rate	: 13.5 Mbps

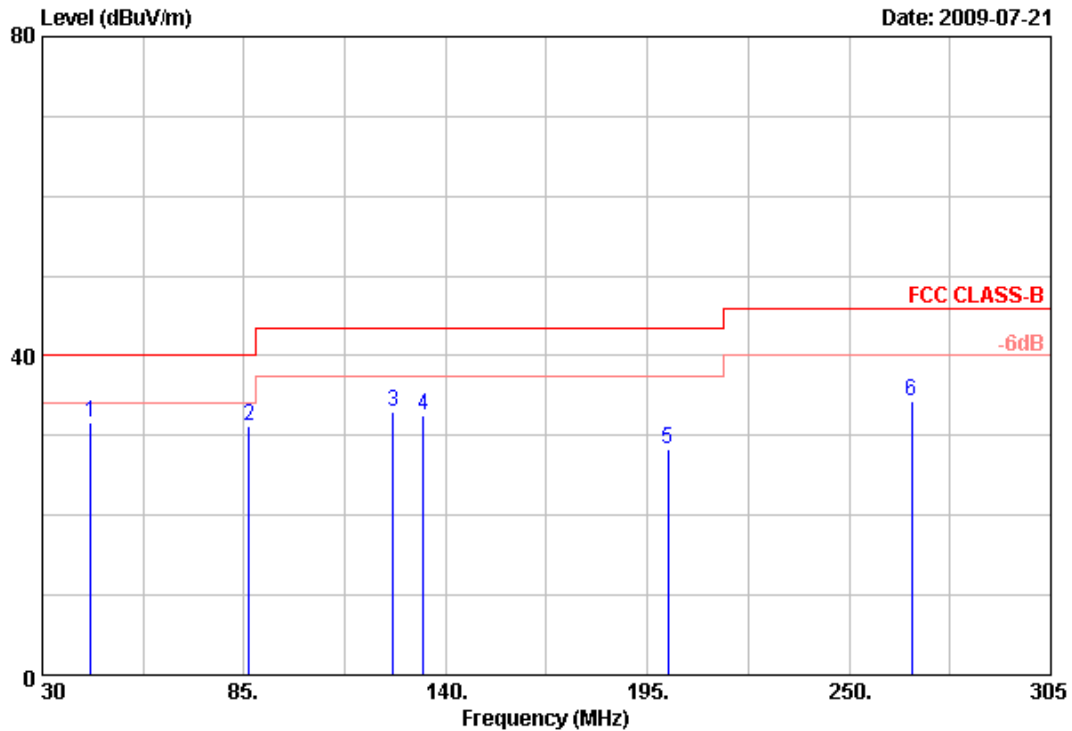

Item	Freq	Read Value	Factor	Result	Limit	Margin	Remark	Ant Pos	Tab Pos
	MHz	dBuV/m	dB	dBuV/m	dBuV/m	dB		cm	Deg
1	43.20	39.25	-7.60	31.65	40.00	-8.35	Peak	100	360
2	86.38	44.61	-13.33	31.28	40.00	-8.72	Peak	100	360
3	125.70	42.34	-9.31	33.03	43.50	-10.47	Peak	100	360
4	133.95	42.17	-9.67	32.50	43.50	-11.00	Peak	100	360
5	200.50	37.68	-9.47	28.21	43.50	-15.29	Peak	100	360
6	267.05	46.87	-12.54	34.33	46.00	-11.67	Peak	100	360

Notes:

1. Result = Read Value + Factor
2. Factor = Antenna Factor + Cable Loss - Amplifier
3. The resolution bandwidth of test receiver/spectrum analyzer is 120KHz and video bandwidth is 300kHz for Peak detection and Quasi-peak detection at frequency below 1GHz.
4. According to technical experiences, all spurious emission of 802.11MIMO mode at channel 3,6,9 are almost the same below 1GHz, so that the channel 3 was chosen as representative in final test.
5. The data is worse case.



Power	: AC 120V	Pol/Phase	: VERTICAL
Test Mode 1	: Transmit / Receive	Temperature	: 26 °C
Operation Channel	: 3	Humidity	: 58 %
Modulation Type	: 802.11n, HT40	Atmospheric Pressure	: 1023 hPa
Memo	: Adapter: FA-1201500SUA	Rate	: 13.5 Mbps

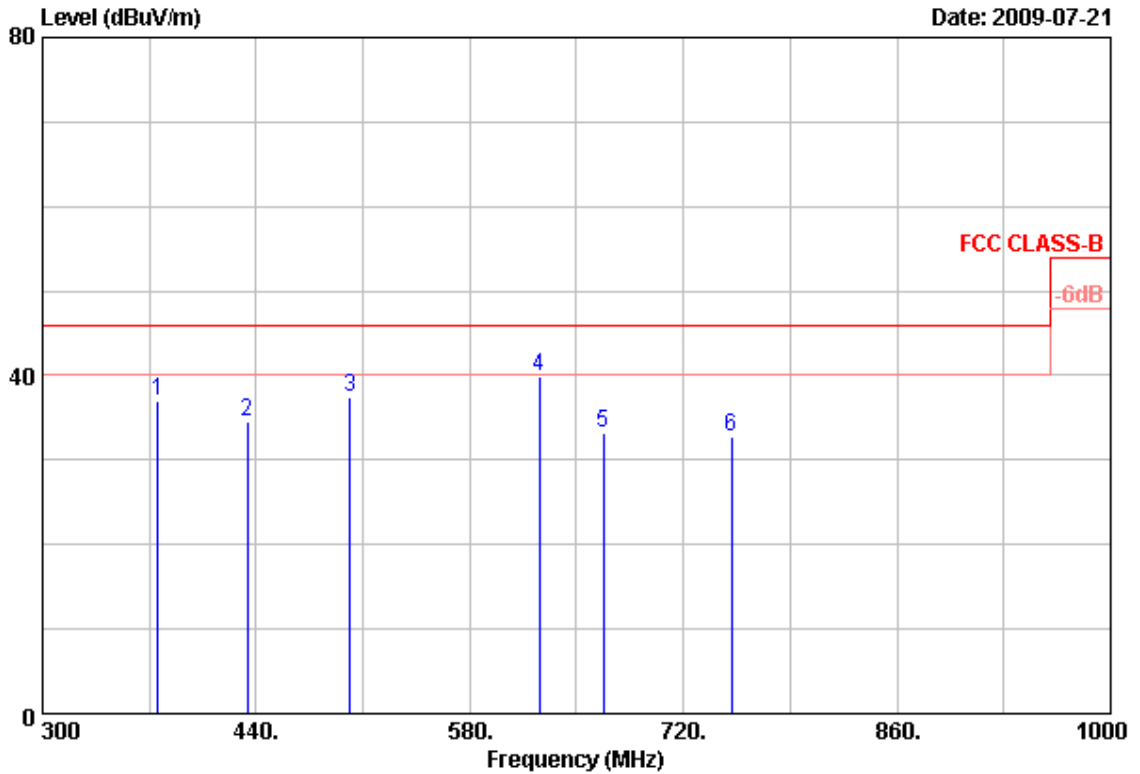

Item	Freq	Read Value	Factor	Result	Limit	Margin	Remark	Ant Pos	Tab Pos
	MHz	dBuV/m	dB	dBuV/m	dBuV/m	dB		cm	Deg
1	375.60	47.22	-10.31	36.91	46.00	-9.09	Peak	100	0
2	434.40	41.85	-7.30	34.55	46.00	-11.45	Peak	100	0
3	501.60	45.79	-8.44	37.35	46.00	-8.65	Peak	100	0
4	625.50	46.51	-6.52	39.99	46.00	-6.01	Peak	100	0
5	667.50	37.22	-3.94	33.28	46.00	-12.72	Peak	100	0
6	751.50	33.75	-1.08	32.67	46.00	-13.33	Peak	100	0

Notes:

1. Result = Read Value + Factor
2. Factor = Antenna Factor + Cable Loss - Amplifier
3. The resolution bandwidth of test receiver/spectrum analyzer is 120KHz and video bandwidth is 300kHz for Peak detection and Quasi-peak detection at frequency below 1GHz.
4. According to technical experiences, all spurious emission of 802.11MIMO mode at channel 3,6,9 are almost the same below 1GHz, so that the channel 3 was chosen as representative in final test.
5. The data is worse case.





Power	: AC 120V	Pol/Phase	: HORIZONTAL
Test Mode 1	: Transmit / Receive	Temperature	: 26 °C
Operation Channel	: 3	Humidity	: 58 %
Modulation Type	: 802.11n, HT40	Atmospheric Pressure	: 1023 hPa
Memo	: Adapter: FA-1201500SUA	Rate	: 13.5 Mbps

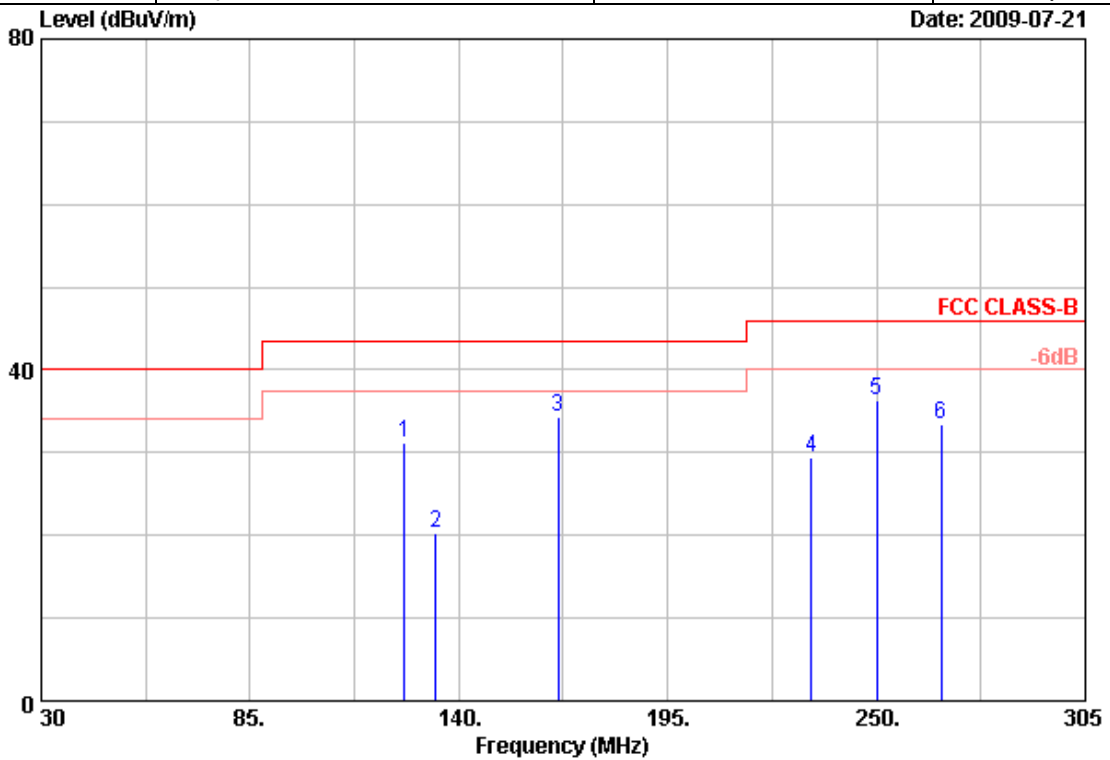

Item	Freq	Read Value	Factor	Result	Limit	Margin	Remark	Ant Pos	Tab Pos
	MHz	dBuV/m	dB	dBuV/m	dBuV/m	dB		cm	Deg
1	125.70	47.79	-16.64	31.15	43.50	-12.35	Peak	100	360
2	133.95	37.06	-16.76	20.30	43.50	-23.20	Peak	100	360
3	166.13	51.46	-17.13	34.33	43.50	-9.17	Peak	100	360
4	232.95	45.55	-16.11	29.44	46.00	-16.56	Peak	100	360
5	250.00	51.61	-15.28	36.33	46.00	-9.67	Peak	100	360
6	267.05	46.94	-13.53	33.41	46.00	-12.59	Peak	100	360

Notes:

1. Result = Read Value + Factor
2. Factor = Antenna Factor + Cable Loss - Amplifier
3. The resolution bandwidth of test receiver/spectrum analyzer is 120KHz and video bandwidth is 300kHz for Peak detection and Quasi-peak detection at frequency below 1GHz.
4. According to technical experiences, all spurious emission of 802.11MIMO mode at channel 3,6,9 are almost the same below 1GHz, so that the channel 3 was chosen as representative in final test.
5. The data is worse case.



Power	: AC 120V	Pol/Phase	: HORIZONTAL
Test Mode 1	: Transmit / Receive	Temperature	: 26 °C
Operation Channel	: 3	Humidity	: 58 %
Modulation Type	: 802.11n, HT40	Atmospheric Pressure	: 1023 hPa
Memo	: Adapter: FA-1201500SUA	Rate	: 13.5 Mbps

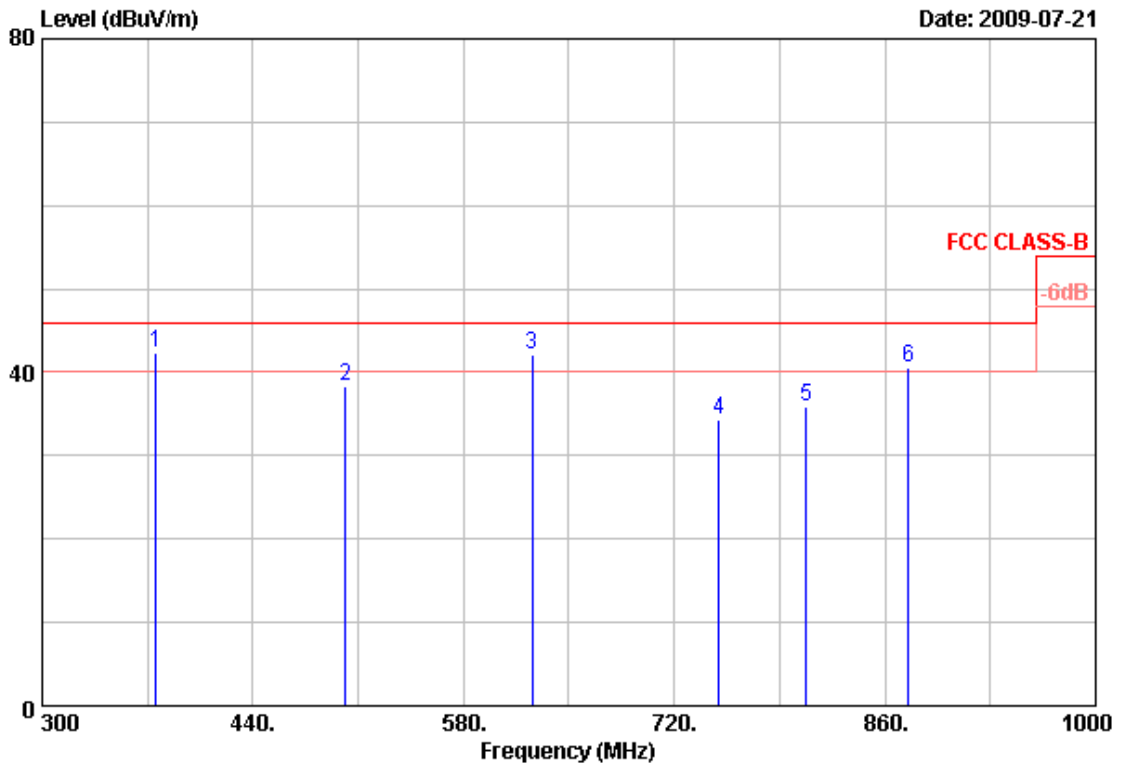

Item	Freq	Read Value	Factor	Result	Limit	Margin	Remark	Ant Pos	Tab Pos
	MHz	dBuV/m	dB	dBuV/m	dBuV/m	dB		cm	Deg
1	375.60	54.01	-11.68	42.33	46.00	-3.67	QP	100	0
2	501.60	43.66	-5.42	38.24	46.00	-7.76	QP	100	0
3	625.50	43.54	-1.45	42.09	46.00	-3.91	QP	100	0
4	749.40	36.13	-1.85	34.28	46.00	-11.72	Peak	100	0
5	807.50	36.29	-0.51	35.78	46.00	-10.22	Peak	100	0
6	875.40	40.54	0.06	40.60	46.00	-5.40	QP	100	0

## Notes:

1. Result = Read Value + Factor
2. Factor = Antenna Factor + Cable Loss - Amplifier
3. The resolution bandwidth of test receiver/spectrum analyzer is 120KHz and video bandwidth is 300kHz for Peak detection and Quasi-peak detection at frequency below 1GHz.
4. According to technical experiences, all spurious emission of 802.11MIMO mode at channel 3,6,9 are almost the same below 1GHz, so that the channel 3 was chosen as representative in final test.
5. The data is worse case.



Power	: AC 120V	Pol/Phase	: VERTICAL
Test Mode 1	: Transmit / Receive	Temperature	: 26 °C
Operation Channel	: 3	Humidity	: 58 %
Modulation Type	: 802.11n, HT40	Atmospheric Pressure	: 1023 hPa
Memo	: Adapter: FA-1201500SUA	Rate	: 13.5 Mbps

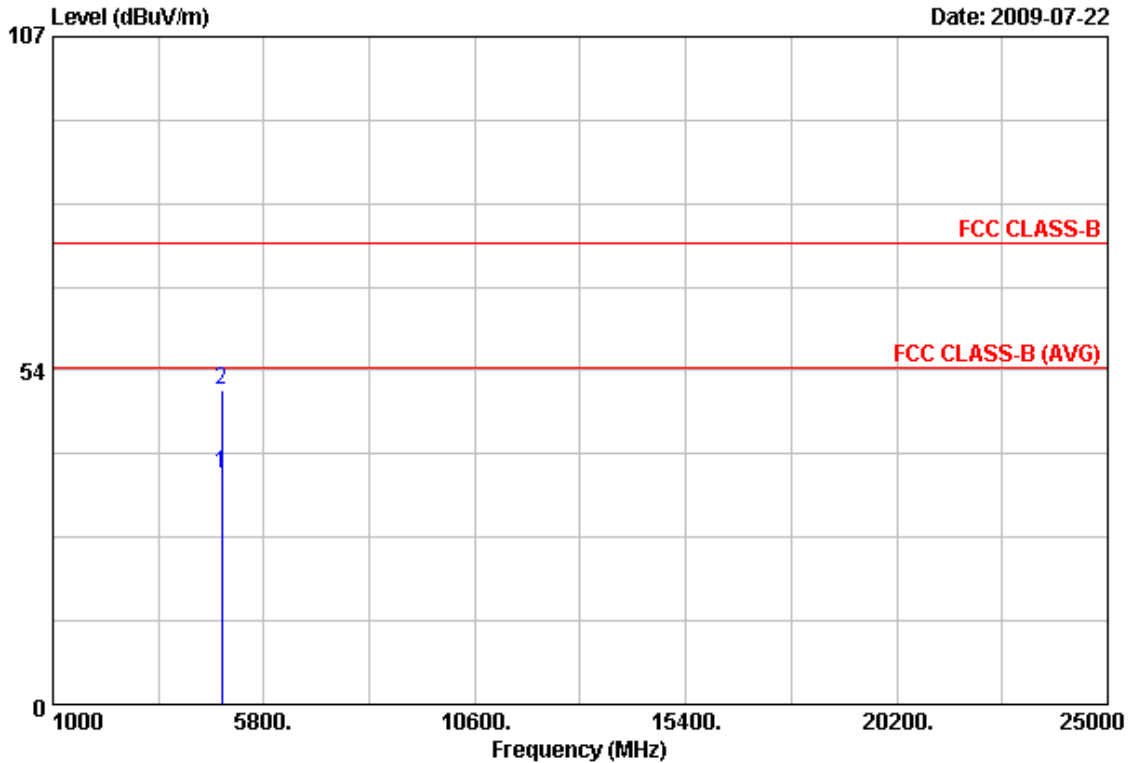

Item	Freq	Read Value	Factor	Result	Limit	Margin	Remark	Ant Pos	Tab Pos
	MHz	dBuV/m	dB	dBuV/m	dBuV/m	dB		cm	Deg
1	4844.75	31.56	5.40	36.96	54.00	-17.04	Average	100	0
2	4844.95	44.93	5.40	50.33	74.00	-23.67	Peak	100	0

Notes:

1. Result = Read Value + Factor
2. Factor = Antenna Factor + Cable Loss - Amplifier
3. The resolution bandwidth of test receiver/spectrum analyzer is 120KHz and video bandwidth is 300kHz for Peak detection and Quasi-peak detection at frequency below 1GHz.
4. The resolution bandwidth of test receiver/spectrum analyzer is 1MHz and video bandwidth is 3MHz for Peak detection at frequency above 1GHz.
5. The resolution bandwidth of test receiver/spectrum analyzer is 1MHz and video bandwidth is 10Hz for Average detection at frequency above 1GHz.
6. The other emissions is too low to be measured.



Power	: AC 120V	Pol/Phase	: HORIZONTAL
Test Mode 1	: Transmit / Receive	Temperature	: 26 °C
Operation Channel	: 3	Humidity	: 58 %
Modulation Type	: 802.11n, HT40	Atmospheric Pressure	: 1023 hPa
Memo	: Adapter: FA-1201500SUA	Rate	: 13.5 Mbps

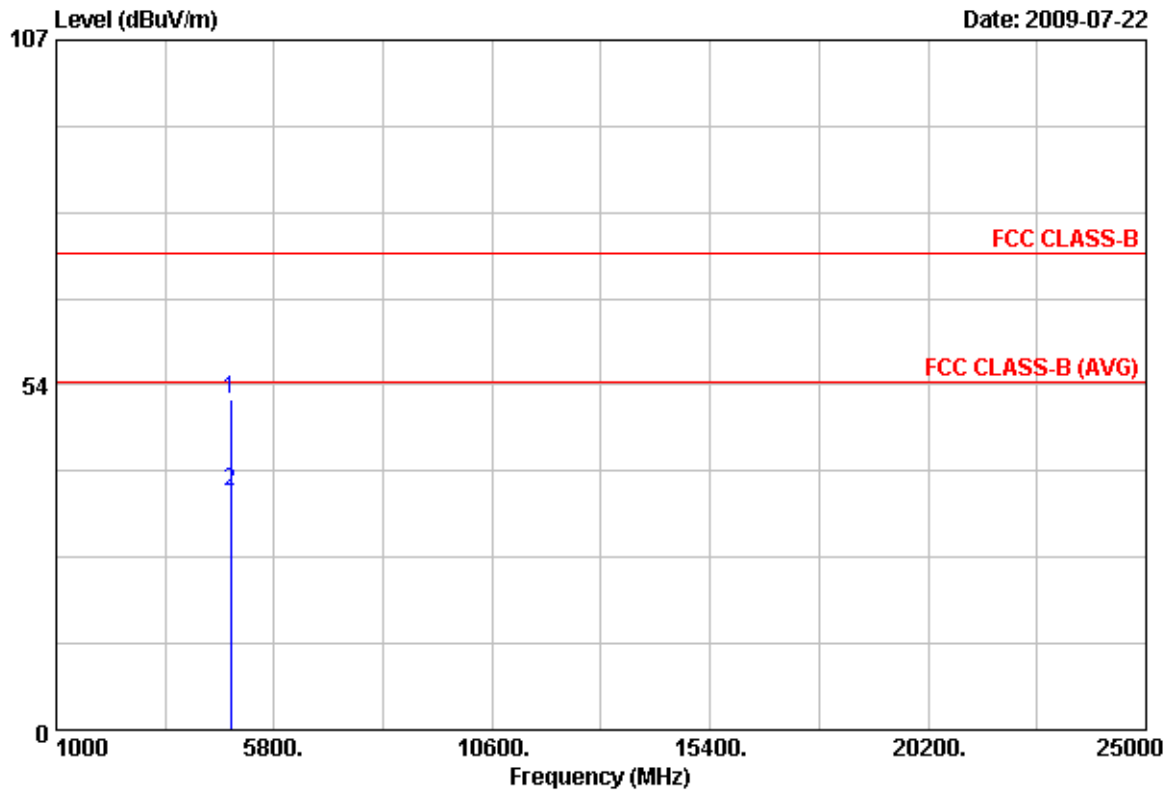

Item	Freq	Read Value	Factor	Result	Limit	Margin	Remark	Ant Pos	Tab Pos
	MHz	dBuV/m	dB	dBuV/m	dBuV/m	dB		cm	Deg
1	4842.45	45.84	5.40	51.24	74.00	-22.76	Peak	100	0
2	4844.85	31.56	5.40	36.96	54.00	-17.04	Average	100	0

Notes:

1. Result = Read Value + Factor
2. Factor = Antenna Factor + Cable Loss - Amplifier
3. The resolution bandwidth of test receiver/spectrum analyzer is 120KHz and video bandwidth is 300kHz for Peak detection and Quasi-peak detection at frequency below 1GHz.
4. The resolution bandwidth of test receiver/spectrum analyzer is 1MHz and video bandwidth is 3MHz for Peak detection at frequency above 1GHz.
5. The resolution bandwidth of test receiver/spectrum analyzer is 1MHz and video bandwidth is 10Hz for Average detection at frequency above 1GHz.
6. The other emissions is too low to be measured.



Power	: AC 120V	Pol/Phase	: VERTICAL
Test Mode 1	: Transmit / Receive	Temperature	: 26 °C
Operation Channel	: 6	Humidity	: 58 %
Modulation Type	: 802.11n, HT40	Atmospheric Pressure	: 1023 hPa
Memo	: Adapter: FA-1201500SUA	Rate	: 13.5 Mbps

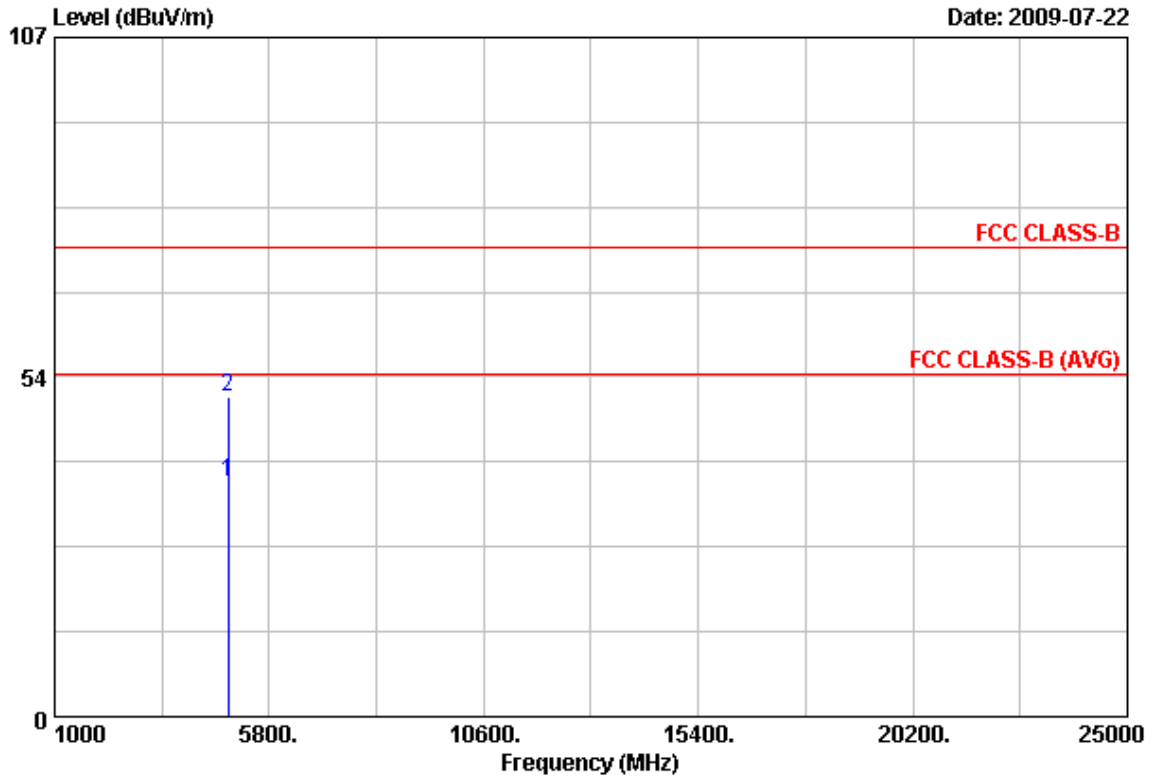

Item	Freq	Read Value	Factor	Result	Limit	Margin	Remark	Ant Pos	Tab Pos
	MHz	dBuV/m	dB	dBuV/m	dBuV/m	dB		cm	Deg
1	4873.50	31.36	5.49	36.85	54.00	-17.15	Average	100	0
2	4873.50	44.84	5.49	50.33	74.00	-23.67	Peak	100	0

Notes:

1. Result = Read Value + Factor
2. Factor = Antenna Factor + Cable Loss - Amplifier
3. The resolution bandwidth of test receiver/spectrum analyzer is 120KHz and video bandwidth is 300kHz for Peak detection and Quasi-peak detection at frequency below 1GHz.
4. The resolution bandwidth of test receiver/spectrum analyzer is 1MHz and video bandwidth is 3MHz for Peak detection at frequency above 1GHz.
5. The resolution bandwidth of test receiver/spectrum analyzer is 1MHz and video bandwidth is 10Hz for Average detection at frequency above 1GHz.
6. The other emissions is too low to be measured.



Power	: AC 120V	Pol/Phase	: HORIZONTAL
Test Mode 1	: Transmit / Receive	Temperature	: 26 °C
Operation Channel	: 6	Humidity	: 58 %
Modulation Type	: 802.11n, HT40	Atmospheric Pressure	: 1023 hPa
Memo	: Adapter: FA-1201500SUA	Rate	: 13.5 Mbps

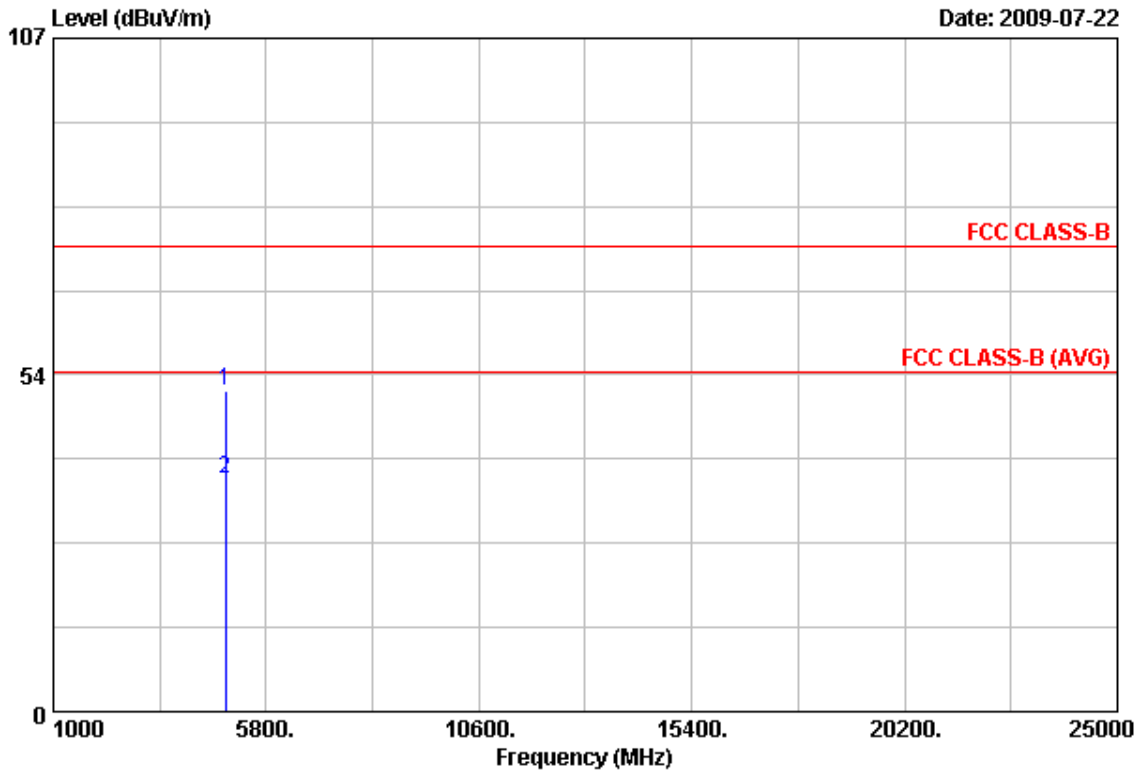

Item	Freq	Read Value	Factor	Result	Limit	Margin	Remark	Ant Pos	Tab Pos
	MHz	dBuV/m	dB	dBuV/m	dBuV/m	dB		cm	Deg
1	4873.50	45.47	5.49	50.96	74.00	-23.04	Peak	100	0
2	4875.40	31.44	5.51	36.95	54.00	-17.05	Average	100	0

Notes:

1. Result = Read Value + Factor
2. Factor = Antenna Factor + Cable Loss - Amplifier
3. The resolution bandwidth of test receiver/spectrum analyzer is 120KHz and video bandwidth is 300kHz for Peak detection and Quasi-peak detection at frequency below 1GHz.
4. The resolution bandwidth of test receiver/spectrum analyzer is 1MHz and video bandwidth is 3MHz for Peak detection at frequency above 1GHz.
5. The resolution bandwidth of test receiver/spectrum analyzer is 1MHz and video bandwidth is 10Hz for Average detection at frequency above 1GHz.
6. The other emissions is too low to be measured.



Power	: AC 120V	Pol/Phase	: VERTICAL
Test Mode 1	: Transmit / Receive	Temperature	: 26 °C
Operation Channel	: 9	Humidity	: 58 %
Modulation Type	: 802.11n, HT40	Atmospheric Pressure	: 1023 hPa
Memo	: Adapter: FA-1201500SUA	Rate	: 13.5 Mbps

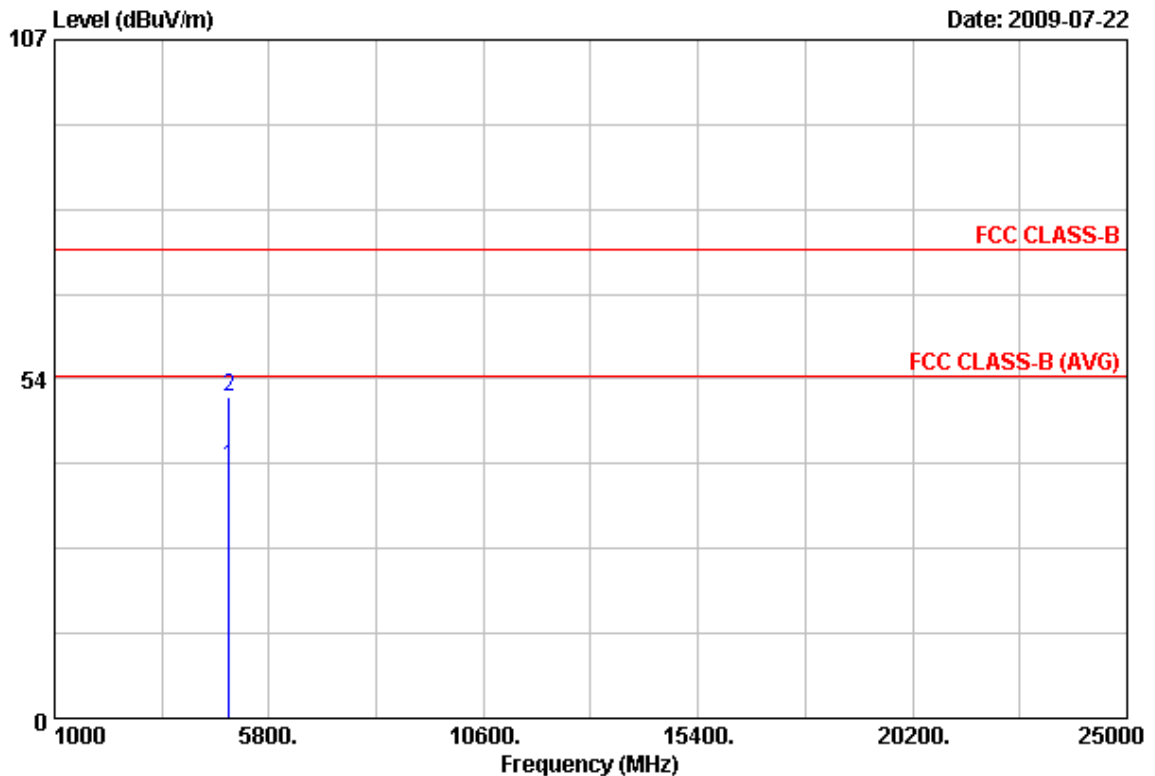

Item	Freq	Read Value	Factor	Result	Limit	Margin	Remark	Ant Pos	Tab Pos
	MHz	dBuV/m	dB	dBuV/m	dBuV/m	dB		cm	Deg
1	4903.30	34.06	5.59	39.65	54.00	-14.35	Average	100	0
2	4904.90	45.06	5.60	50.66	74.00	-23.34	Peak	100	0

Notes:

1. Result = Read Value + Factor
2. Factor = Antenna Factor + Cable Loss - Amplifier
3. The resolution bandwidth of test receiver/spectrum analyzer is 120KHz and video bandwidth is 300kHz for Peak detection and Quasi-peak detection at frequency below 1GHz.
4. The resolution bandwidth of test receiver/spectrum analyzer is 1MHz and video bandwidth is 3MHz for Peak detection at frequency above 1GHz.
5. The resolution bandwidth of test receiver/spectrum analyzer is 1MHz and video bandwidth is 10Hz for Average detection at frequency above 1GHz.
6. The other emissions is too low to be measured.



Power	: AC 120V	Pol/Phase	: HORIZONTAL
Test Mode 1	: Transmit / Receive	Temperature	: 26 °C
Operation Channel	: 9	Humidity	: 58 %
Modulation Type	: 802.11n, HT40	Atmospheric Pressure	: 1023 hPa
Memo	: Adapter: FA-1201500SUA	Rate	: 13.5 Mbps

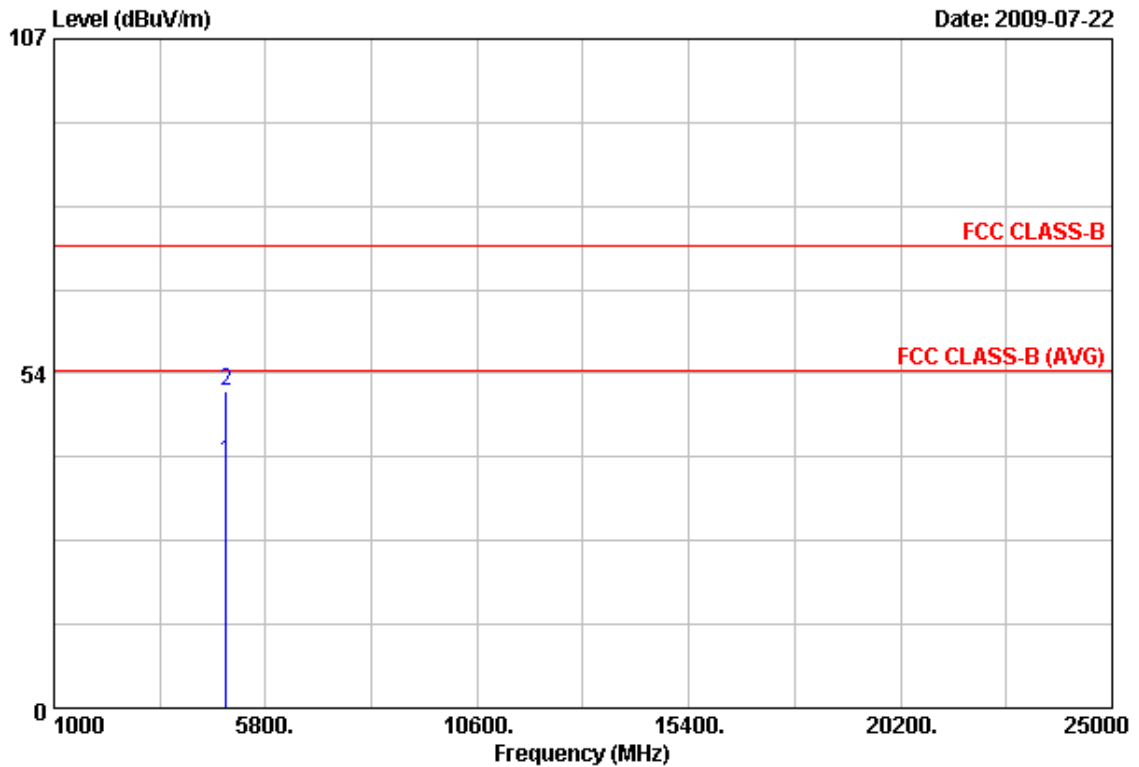

Item	Freq	Read Value	Factor	Result	Limit	Margin	Remark	Ant Pos	Tab Pos
	MHz	dBuV/m	dB	dBuV/m	dBuV/m	dB		cm	Deg
1	4902.35	33.79	5.58	39.37	54.00	-14.63	Average	100	0
2	4903.35	45.06	5.59	50.65	74.00	-23.35	Peak	100	0

Notes:

1. Result = Read Value + Factor
2. Factor = Antenna Factor + Cable Loss - Amplifier
3. The resolution bandwidth of test receiver/spectrum analyzer is 120KHz and video bandwidth is 300kHz for Peak detection and Quasi-peak detection at frequency below 1GHz.
4. The resolution bandwidth of test receiver/spectrum analyzer is 1MHz and video bandwidth is 3MHz for Peak detection at frequency above 1GHz.
5. The resolution bandwidth of test receiver/spectrum analyzer is 1MHz and video bandwidth is 10Hz for Average detection at frequency above 1GHz.
6. The other emissions is too low to be measured.





Power	: AC 120V	Pol/Phase	: VERTICAL
Test Mode 2	: Transmit / Receive	Temperature	: 26 °C
Operation Channel	: 1	Humidity	: 58 %
Modulation Type	: 802.11g	Atmospheric Pressure	: 1023 hPa
Memo	: Adapter: AD661F0916BLF	Rate	: 11 Mbps

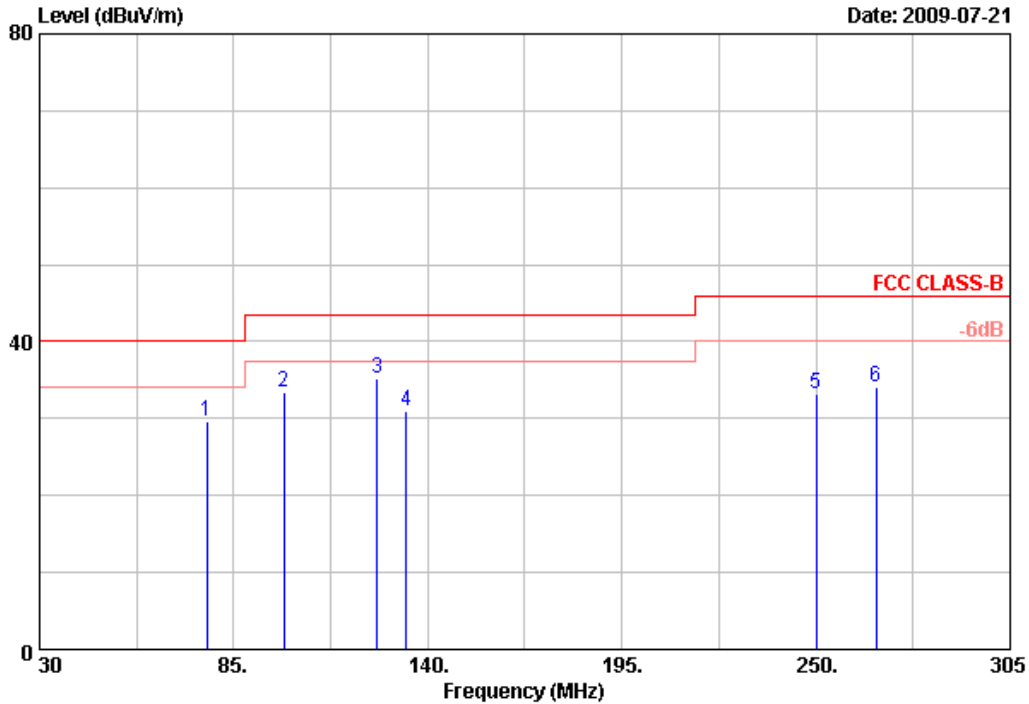

Item	Freq	Read Value	Factor	Result	Limit	Margin	Remark	Ant Pos	Tab Pos
	MHz	dBuV/m	dB	dBuV/m	dBuV/m	dB		cm	Deg
1	77.30	44.52	-14.85	29.67	40.00	-10.33	Peak	100	360
2	99.30	45.05	-11.72	33.33	43.50	-10.17	Peak	100	360
3	125.70	44.41	-9.31	35.10	43.50	-8.40	Peak	100	360
4	133.95	40.63	-9.67	30.96	43.50	-12.54	Peak	100	360
5	250.00	45.92	-12.64	33.28	46.00	-12.72	Peak	100	360
6	267.05	46.71	-12.54	34.17	46.00	-11.83	Peak	100	360

Notes:

1. Result = Read Value + Factor
2. Factor = Antenna Factor + Cable Loss - Amplifier
3. The resolution bandwidth of test receiver/spectrum analyzer is 120KHz and video bandwidth is 300kHz for Peak detection and Quasi-peak detection at frequency below 1GHz.
4. All emission below 1GHz at 802.11b/g mode are all the same,so the 802.11g mode chosen as representative in final test.
5. According to technical experiences,all spurious emission of 802.11b mode at channel 1,6,11 are almost the same below 1GHz,so that the channel 1 was chosen as representative in final test.
6. The data is worse case.



Power	: AC 120V	Pol/Phase	: VERTICAL
Test Mode 2	: Transmit / Receive	Temperature	: 26 °C
Operation Channel	: 1	Humidity	: 58 %
Modulation Type	: 802.11g	Atmospheric Pressure	: 1023 hPa
Memo	: Adapter: AD661F0916BLF	Rate	: 11 Mbps

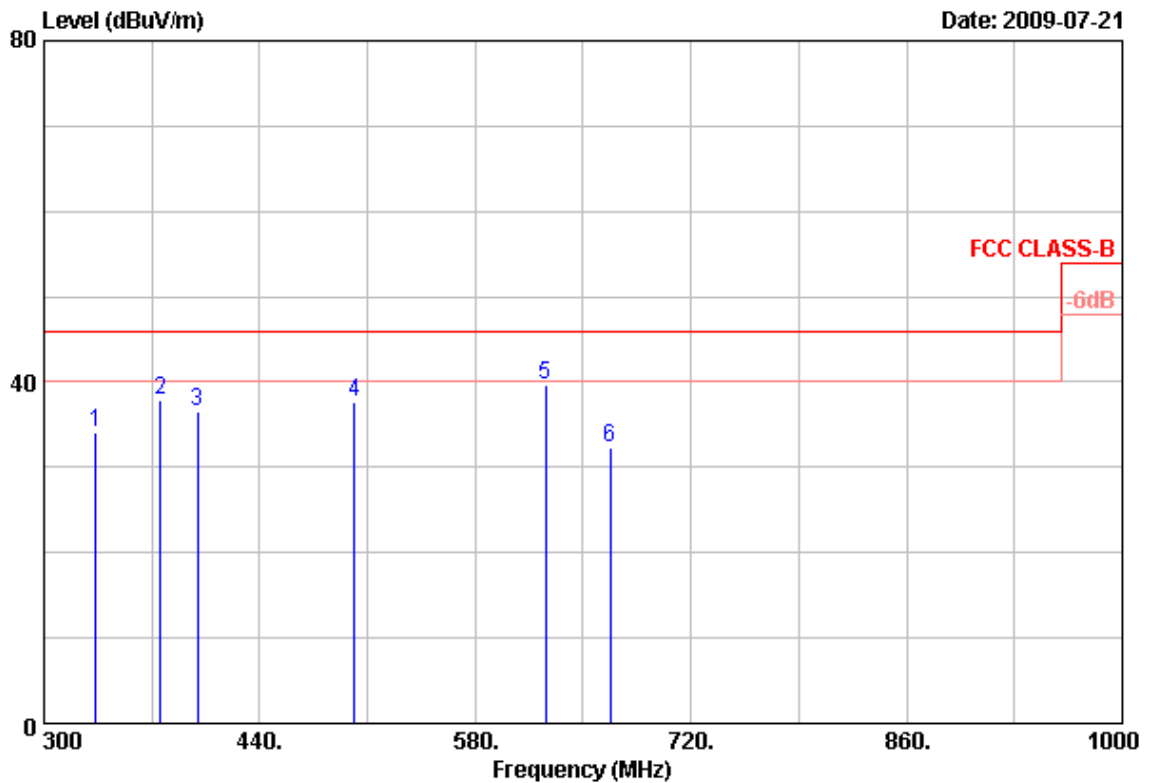

Item	Freq	Read Value	Factor	Result	Limit	Margin	Remark	Ant Pos	Tab Pos
	MHz	dBuV/m	dB	dBuV/m	dBuV/m	dB		cm	Deg
1	333.60	45.47	-11.43	34.04	46.00	-11.96	Peak	100	0
2	375.60	48.19	-10.31	37.88	46.00	-8.12	Peak	100	0
3	399.40	43.60	-6.97	36.63	46.00	-9.37	Peak	100	0
4	501.60	46.20	-8.44	37.76	46.00	-8.24	Peak	100	0
5	625.50	46.27	-6.52	39.75	46.00	-6.25	Peak	100	0
6	667.50	36.23	-3.94	32.29	46.00	-13.71	Peak	100	0

Notes:

1. Result = Read Value + Factor
2. Factor = Antenna Factor + Cable Loss - Amplifier
3. The resolution bandwidth of test receiver/spectrum analyzer is 120KHz and video bandwidth is 300kHz for Peak detection and Quasi-peak detection at frequency below 1GHz.
4. All emission below 1GHz at 802.11b/g mode are all the same,so the 802.11g mode chosen as representative in final test.
5. According to technical experiences,all spurious emission of 802.11b mode at channel 1,6,11 are almost the same below 1GHz,so that the channel 1 was chosen as representative in final test.
6. The data is worse case.



Power	: AC 120V	Pol/Phase	: HORIZONTAL
Test Mode 2	: Transmit / Receive	Temperature	: 26 °C
Operation Channel	: 1	Humidity	: 58 %
Modulation Type	: 802.11g	Atmospheric Pressure	: 1023 hPa
Memo	: Adapter: AD661F0916BLF	Rate	: 11 Mbps

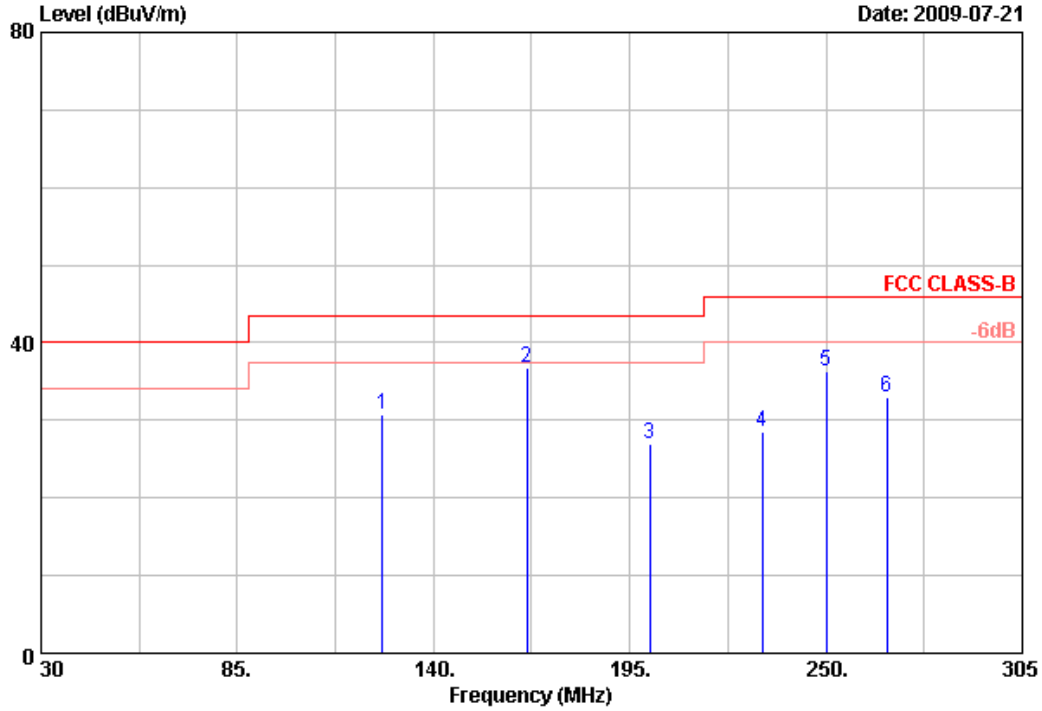

Item	Freq	Read Value	Factor	Result	Limit	Margin	Remark	Ant Pos	Tab Pos
	MHz	dBuV/m	dB	dBuV/m	dBuV/m	dB		cm	Deg
1	125.70	47.47	-16.64	30.83	43.50	-12.67	Peak	100	360
2	166.13	53.90	-17.13	36.77	43.50	-6.73	Peak	100	360
3	200.50	44.23	-17.21	27.02	43.50	-16.48	Peak	100	360
4	232.13	44.54	-16.12	28.42	46.00	-17.58	Peak	100	360
5	250.00	51.59	-15.28	36.31	46.00	-9.69	Peak	100	360
6	267.05	46.54	-13.53	33.01	46.00	-12.99	Peak	100	360

Notes:

1. Result = Read Value + Factor
2. Factor = Antenna Factor + Cable Loss - Amplifier
3. The resolution bandwidth of test receiver/spectrum analyzer is 120KHz and video bandwidth is 300kHz for Peak detection and Quasi-peak detection at frequency below 1GHz.
4. All emission below 1GHz at 802.11b/g mode are all the same,so the 802.11g mode chosen as representative in final test.
5. According to technical experiences,all spurious emission of 802.11b mode at channel 1,6,11 are almost the same below 1GHz,so that the channel 1 was chosen as representative in final test.
6. The data is worse case.



Power	: AC 120V	Pol/Phase	: HORIZONTAL
Test Mode 2	: Transmit / Receive	Temperature	: 26 °C
Operation Channel	: 1	Humidity	: 58 %
Modulation Type	: 802.11g	Atmospheric Pressure	: 1023 hPa
Memo	: Adapter: AD661F0916BLF	Rate	: 11 Mbps

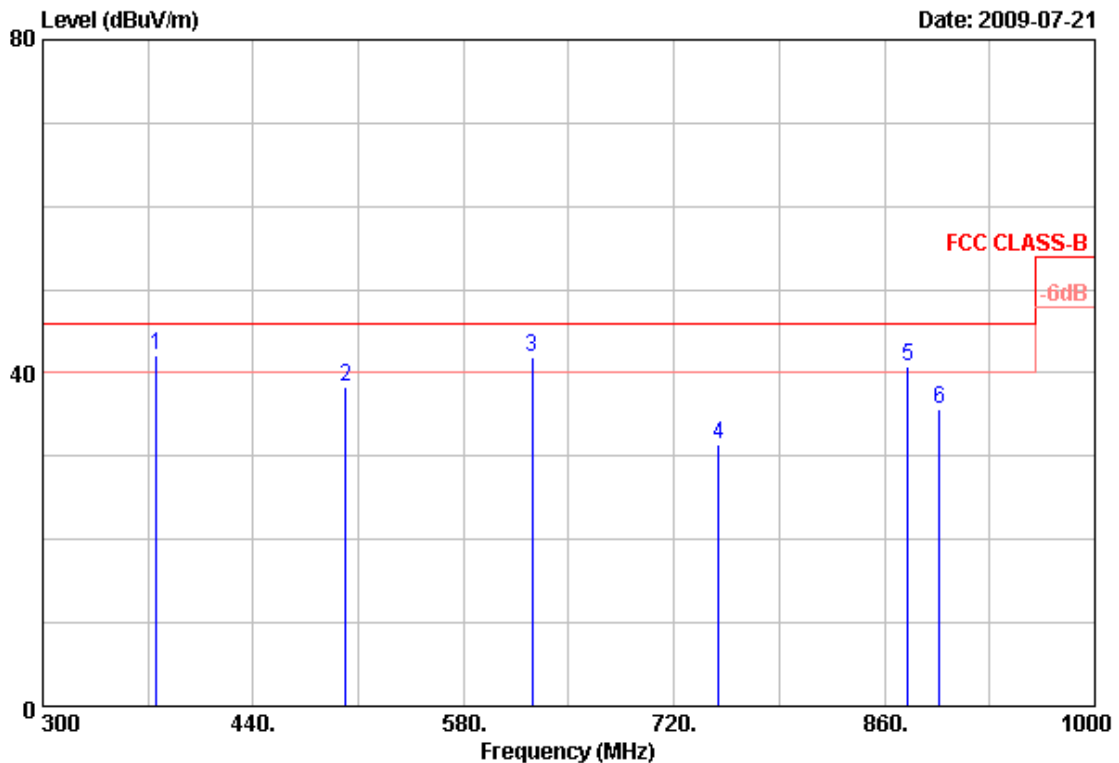

Item	Freq	Read Value	Factor	Result	Limit	Margin	Remark	Ant Pos	Tab Pos
	MHz	dBuV/m	dB	dBuV/m	dBuV/m	dB		cm	Deg
1	375.60	53.89	-11.68	42.21	46.00	-3.79	QP	100	0
2	501.60	43.70	-5.42	38.28	46.00	-7.72	Peak	100	0
3	625.50	43.36	-1.45	41.91	46.00	-4.09	QP	100	0
4	749.40	33.18	-1.85	31.33	46.00	-14.67	Peak	100	0
5	875.40	40.68	0.06	40.74	46.00	-5.26	QP	100	0
6	896.40	34.22	1.46	35.68	46.00	-10.32	Peak	100	0

## Notes:

1. Result = Read Value + Factor
2. Factor = Antenna Factor + Cable Loss - Amplifier
3. The resolution bandwidth of test receiver/spectrum analyzer is 120KHz and video bandwidth is 300kHz for Peak detection and Quasi-peak detection at frequency below 1GHz.
4. All emission below 1GHz at 802.11b/g mode are all the same,so the 802.11g mode chosen as representative in final test.
5. According to technical experiences,all spurious emission of 802.11b mode at channel 1,6,11 are almost the same below 1GHz,so that the channel 1 was chosen as representative in final test.
6. The data is worse case.



Power	: AC 120V	Pol/Phase	: VERTICAL
Test Mode 2	: Transmit / Receive	Temperature	: 26 °C
Operation Channel	: 1	Humidity	: 58 %
Modulation Type	: 802.11b	Atmospheric Pressure	: 1023 hPa
Memo	: Adapter: AD661F0916BLF	Rate	: 11 Mbps

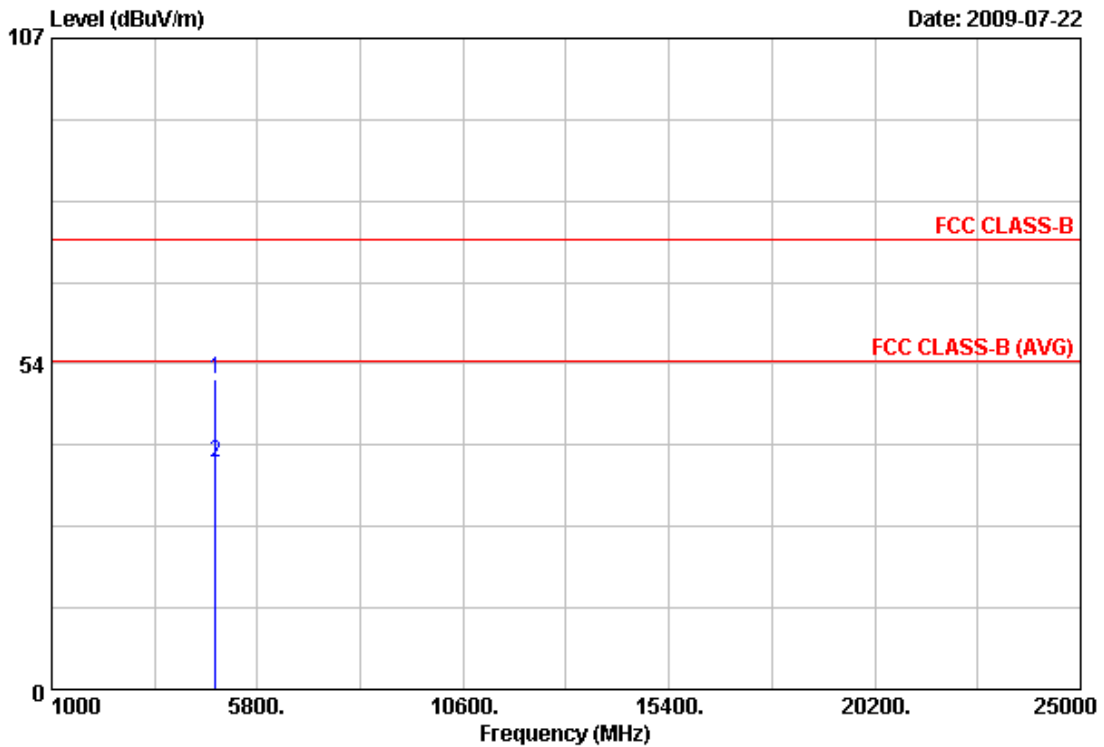

Item	Freq	Read Value	Factor	Result	Limit	Margin	Remark	Ant Pos	Tab Pos
	MHz	dBuV/m	dB	dBuV/m	dBuV/m	dB		cm	Deg
1	4822.85	45.62	5.33	50.95	74.00	-23.05	Peak	100	360
2	4823.60	32.03	5.33	37.36	54.00	-16.64	Average	100	360

Notes:

1. Result = Read Value + Factor
2. Factor = Antenna Factor + Cable Loss - Amplifier
3. The resolution bandwidth of test receiver/spectrum analyzer is 120KHz and video bandwidth is 300kHz for Peak detection and Quasi-peak detection at frequency below 1GHz.
4. The resolution bandwidth of test receiver/spectrum analyzer is 1MHz and video bandwidth is 3MHz for Peak detection at frequency above 1GHz.
5. The resolution bandwidth of test receiver/spectrum analyzer is 1MHz and video bandwidth is 10Hz for Average detection at frequency above 1GHz.
6. The other emissions is too low to be measured.



Power	: AC 120V	Pol/Phase	: HORIZONTAL
Test Mode 2	: Transmit / Receive	Temperature	: 26 °C
Operation Channel	: 1	Humidity	: 58 %
Modulation Type	: 802.11b	Atmospheric Pressure	: 1023 hPa
Memo	: Adapter: AD661F0916BLF	Rate	: 11 Mbps

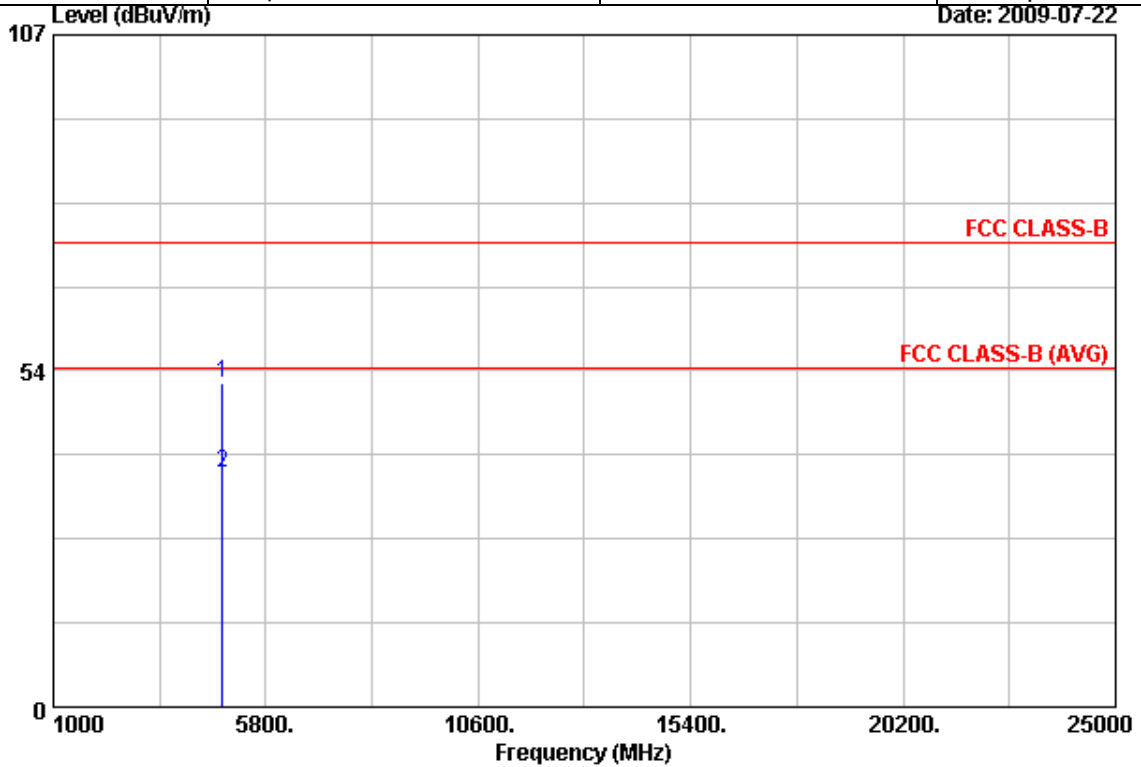

Item	Freq	Read Value	Factor	Result	Limit	Margin	Remark	Ant Pos	Tab Pos
	MHz	dBuV/m	dB	dBuV/m	dBuV/m	dB		cm	Deg
1	4822.85	46.22	5.33	51.55	74.00	-22.45	Peak	100	0
2	4823.35	31.81	5.33	37.14	54.00	-16.86	Average	100	0

Notes:

1. Result = Read Value + Factor
2. Factor = Antenna Factor + Cable Loss - Amplifier
3. The resolution bandwidth of test receiver/spectrum analyzer is 120KHz and video bandwidth is 300kHz for Peak detection and Quasi-peak detection at frequency below 1GHz.
4. The resolution bandwidth of test receiver/spectrum analyzer is 1MHz and video bandwidth is 3MHz for Peak detection at frequency above 1GHz.
5. The resolution bandwidth of test receiver/spectrum analyzer is 1MHz and video bandwidth is 10Hz for Average detection at frequency above 1GHz.
6. The other emissions is too low to be measured.



Power	: AC 120V	Pol/Phase	: VERTICAL
Test Mode 2	: Transmit / Receive	Temperature	: 26 °C
Operation Channel	: 6	Humidity	: 58 %
Modulation Type	: 802.11b	Atmospheric Pressure	: 1023 hPa
Memo	: Adapter: AD661F0916BLF	Rate	: 11 Mbps

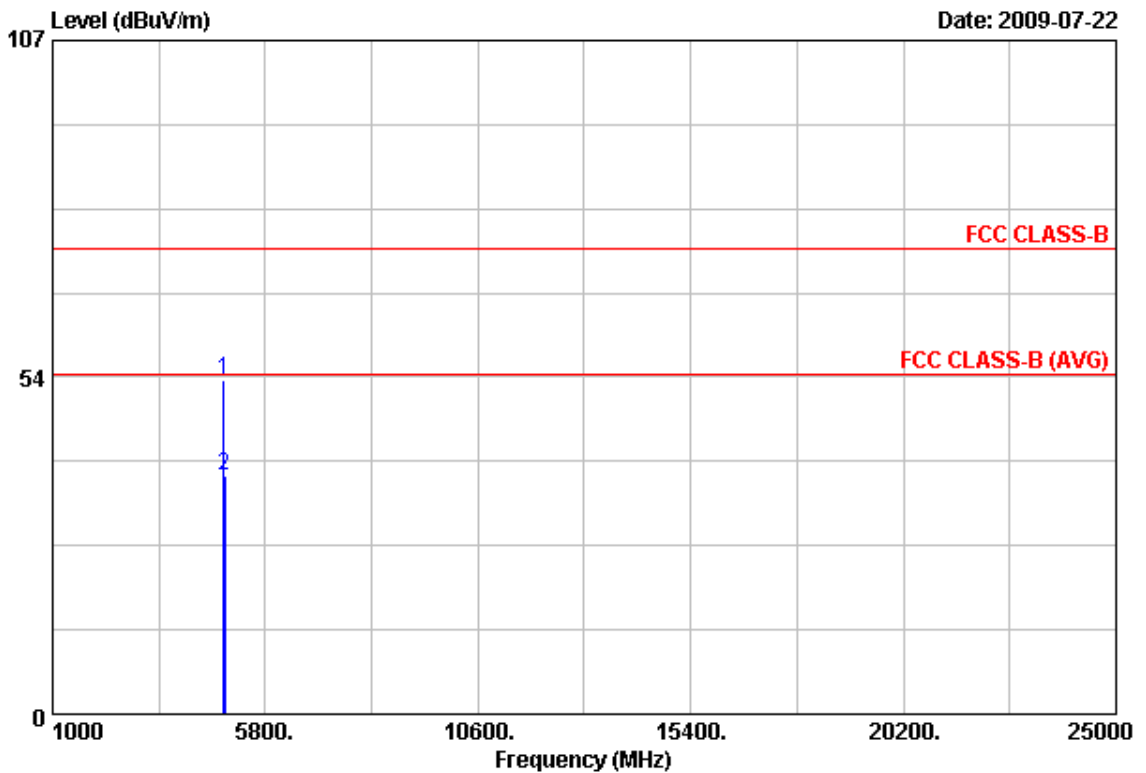

Item	Freq	Read Value	Factor	Result	Limit	Margin	Remark	Ant Pos	Tab Pos
	MHz	dBuV/m	dB	dBuV/m	dBuV/m	dB		cm	Deg
1	4870.10	47.71	5.48	53.19	74.00	-20.81	Peak	100	360
2	4873.25	32.37	5.49	37.86	54.00	-16.14	Average	100	360

Notes:

1. Result = Read Value + Factor
2. Factor = Antenna Factor + Cable Loss - Amplifier
3. The resolution bandwidth of test receiver/spectrum analyzer is 120KHz and video bandwidth is 300kHz for Peak detection and Quasi-peak detection at frequency below 1GHz.
4. The resolution bandwidth of test receiver/spectrum analyzer is 1MHz and video bandwidth is 3MHz for Peak detection at frequency above 1GHz.
5. The resolution bandwidth of test receiver/spectrum analyzer is 1MHz and video bandwidth is 10Hz for Average detection at frequency above 1GHz.
6. The other emissions is too low to be measured.



Power	: AC 120V	Pol/Phase	: HORIZONTAL
Test Mode 2	: Transmit / Receive	Temperature	: 26 °C
Operation Channel	: 6	Humidity	: 58 %
Modulation Type	: 802.11b	Atmospheric Pressure	: 1023 hPa
Memo	: Adapter: AD661F0916BLF	Rate	: 11 Mbps

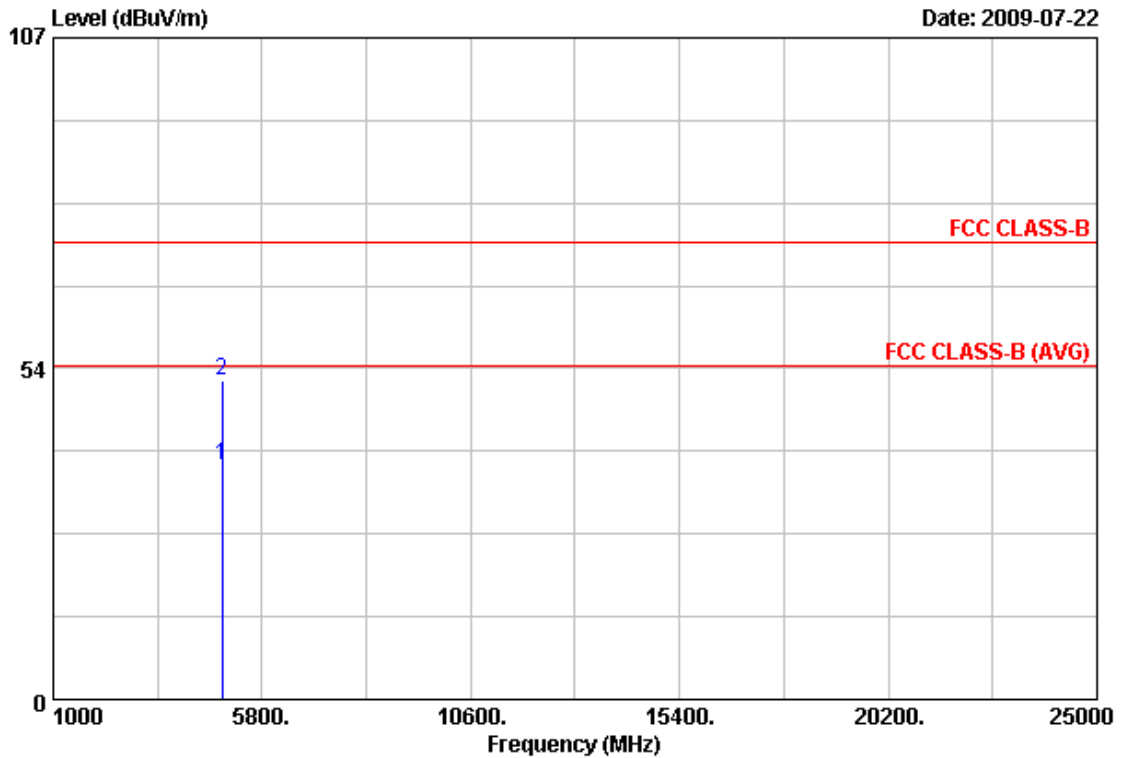

Item	Freq	Read Value	Factor	Result	Limit	Margin	Remark	Ant Pos	Tab Pos
	MHz	dBuV/m	dB	dBuV/m	dBuV/m	dB		cm	Deg
1	4873.30	32.48	5.49	37.97	54.00	-16.03	Average	100	0
2	4874.60	46.15	5.49	51.64	74.00	-22.36	Peak	100	0

Notes:

1. Result = Read Value + Factor
2. Factor = Antenna Factor + Cable Loss - Amplifier
3. The resolution bandwidth of test receiver/spectrum analyzer is 120KHz and video bandwidth is 300kHz for Peak detection and Quasi-peak detection at frequency below 1GHz.
4. The resolution bandwidth of test receiver/spectrum analyzer is 1MHz and video bandwidth is 3MHz for Peak detection at frequency above 1GHz.
5. The resolution bandwidth of test receiver/spectrum analyzer is 1MHz and video bandwidth is 10Hz for Average detection at frequency above 1GHz.
6. The other emissions is too low to be measured.





Power	: AC 120V	Pol/Phase	: VERTICAL
Test Mode 2	: Transmit / Receive	Temperature	: 26 °C
Operation Channel	: 11	Humidity	: 58 %
Modulation Type	: 802.11b	Atmospheric Pressure	: 1023 hPa
Memo	: Adapter: AD661F0916BLF	Rate	: 11 Mbps

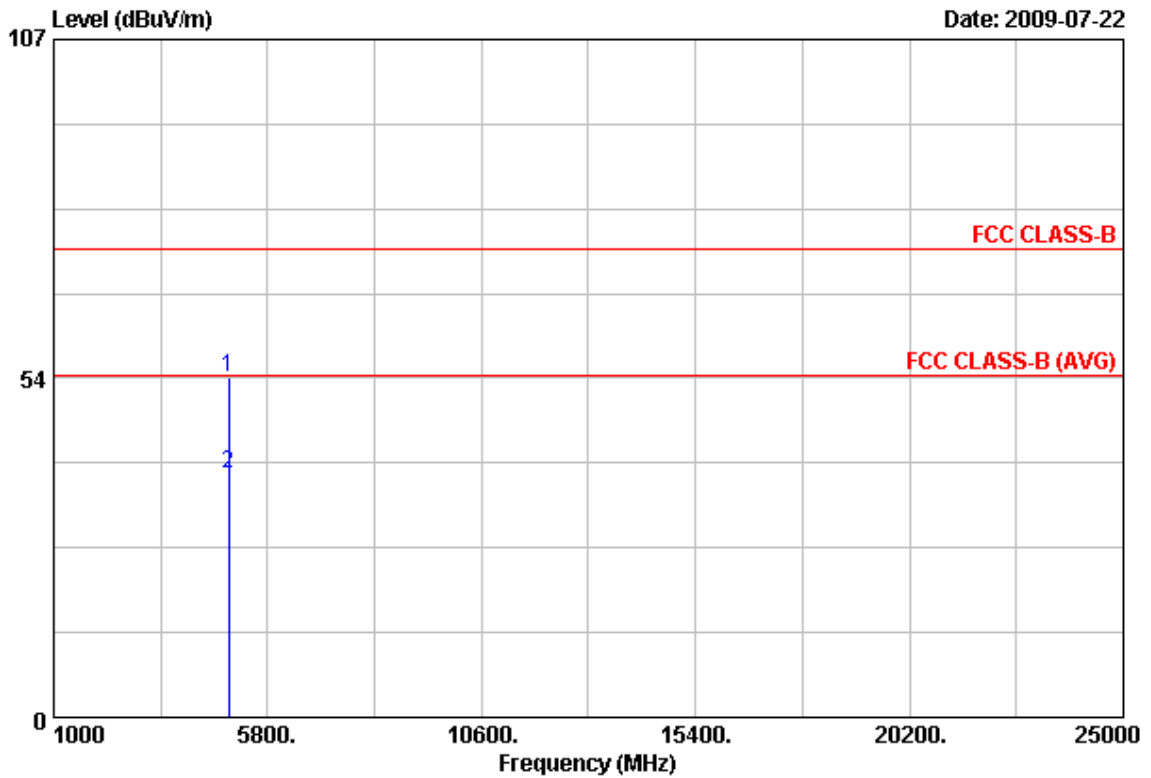

Item	Freq	Read Value	Factor	Result	Limit	Margin	Remark	Ant Pos	Tab Pos
	MHz	dBuV/m	dB	dBuV/m	dBuV/m	dB		cm	Deg
1	4921.90	48.07	5.65	53.72	74.00	-20.28	Peak	100	360
2	4922.50	32.70	5.65	38.35	54.00	-15.65	Average	100	360

Notes:

1. Result = Read Value + Factor
2. Factor = Antenna Factor + Cable Loss - Amplifier
3. The resolution bandwidth of test receiver/spectrum analyzer is 120KHz and video bandwidth is 300kHz for Peak detection and Quasi-peak detection at frequency below 1GHz.
4. The resolution bandwidth of test receiver/spectrum analyzer is 1MHz and video bandwidth is 3MHz for Peak detection at frequency above 1GHz.
5. The resolution bandwidth of test receiver/spectrum analyzer is 1MHz and video bandwidth is 10Hz for Average detection at frequency above 1GHz.
6. The other emissions is too low to be measured.



Power	: AC 120V	Pol/Phase	: HORIZONTAL
Test Mode 2	: Transmit / Receive	Temperature	: 26 °C
Operation Channel	: 11	Humidity	: 58 %
Modulation Type	: 802.11b	Atmospheric Pressure	: 1023 hPa
Memo	: Adapter: AD661F0916BLF	Rate	: 11 Mbps

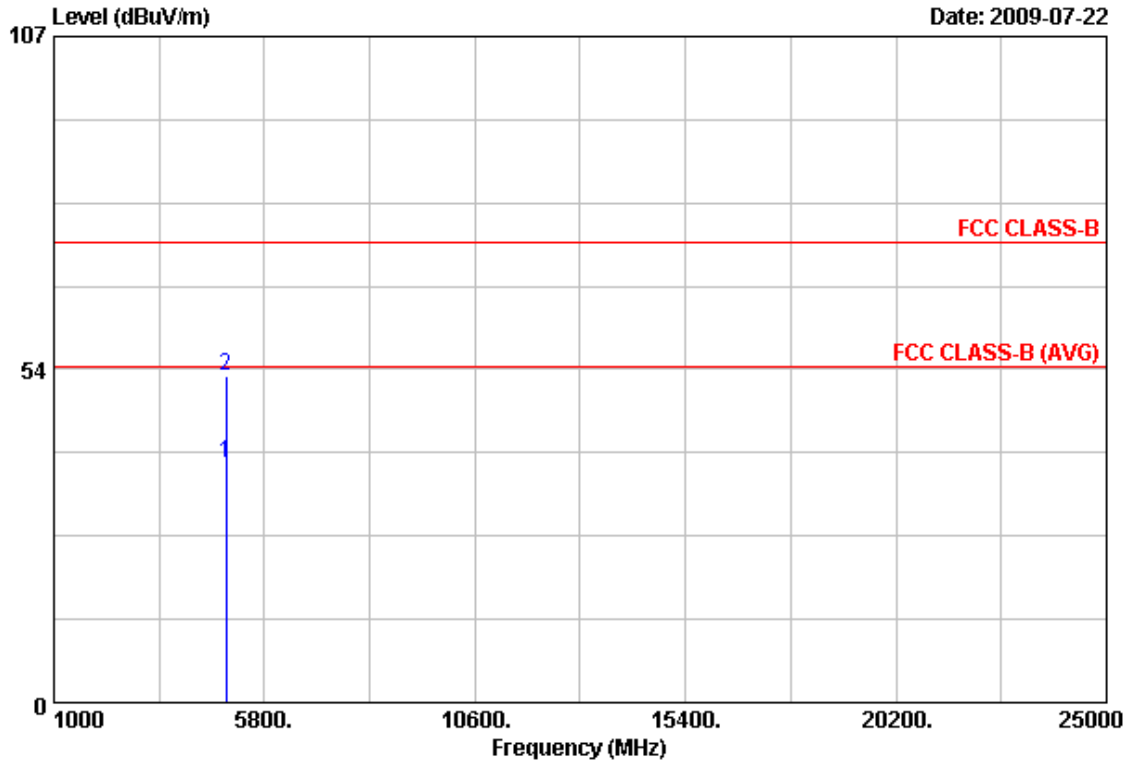

Item	Freq	Read Value	Factor	Result	Limit	Margin	Remark	Ant Pos	Tab Pos
	MHz	dBuV/m	dB	dBuV/m	dBuV/m	dB		cm	Deg
1	4923.20	32.77	5.65	38.42	54.00	-15.58	Average	100	0
2	4923.20	46.71	5.65	52.36	74.00	-21.64	Peak	100	0

Notes:

1. Result = Read Value + Factor
2. Factor = Antenna Factor + Cable Loss - Amplifier
3. The resolution bandwidth of test receiver/spectrum analyzer is 120KHz and video bandwidth is 300kHz for Peak detection and Quasi-peak detection at frequency below 1GHz.
4. The resolution bandwidth of test receiver/spectrum analyzer is 1MHz and video bandwidth is 3MHz for Peak detection at frequency above 1GHz.
5. The resolution bandwidth of test receiver/spectrum analyzer is 1MHz and video bandwidth is 10Hz for Average detection at frequency above 1GHz.
6. The other emissions is too low to be measured.



Power	: AC 120V	Pol/Phase	: VERTICAL
Test Mode 2	: Transmit / Receive	Temperature	: 26 °C
Operation Channel	: 1	Humidity	: 58 %
Modulation Type	: 802.11g	Atmospheric Pressure	: 1023 hPa
Memo	: Adapter: AD661F0916BLF	Rate	: 6 Mbps

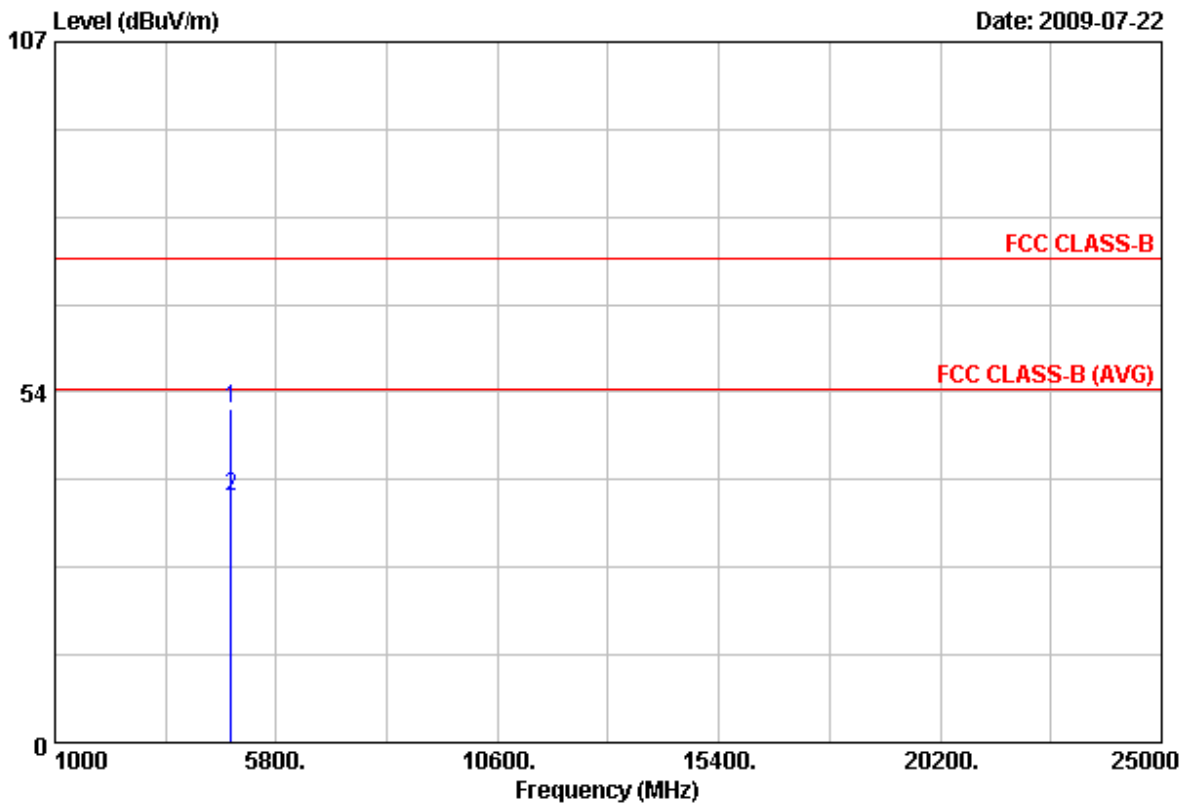

Item	Freq	Read Value	Factor	Result	Limit	Margin	Remark	Ant Pos	Tab Pos
	MHz	dBuV/m	dB	dBuV/m	dBuV/m	dB		cm	Deg
1	4822.90	45.67	5.33	51.00	74.00	-23.00	Peak	100	360
2	4824.70	32.22	5.33	37.55	54.00	-16.45	Average	100	360

Notes:

1. Result = Read Value + Factor
2. Factor = Antenna Factor + Cable Loss - Amplifier
3. The resolution bandwidth of test receiver/spectrum analyzer is 120KHz and video bandwidth is 300kHz for Peak detection and Quasi-peak detection at frequency below 1GHz.
4. The resolution bandwidth of test receiver/spectrum analyzer is 1MHz and video bandwidth is 3MHz for Peak detection at frequency above 1GHz.
5. The resolution bandwidth of test receiver/spectrum analyzer is 1MHz and video bandwidth is 10Hz for Average detection at frequency above 1GHz.
6. The other emissions is too low to be measured.



Power	: AC 120V	Pol/Phase	: HORIZONTAL
Test Mode 2	: Transmit / Receive	Temperature	: 26 °C
Operation Channel	: 1	Humidity	: 58 %
Modulation Type	: 802.11g	Atmospheric Pressure	: 1023 hPa
Memo	: Adapter: AD661F0916BLF	Rate	: 6 Mbps

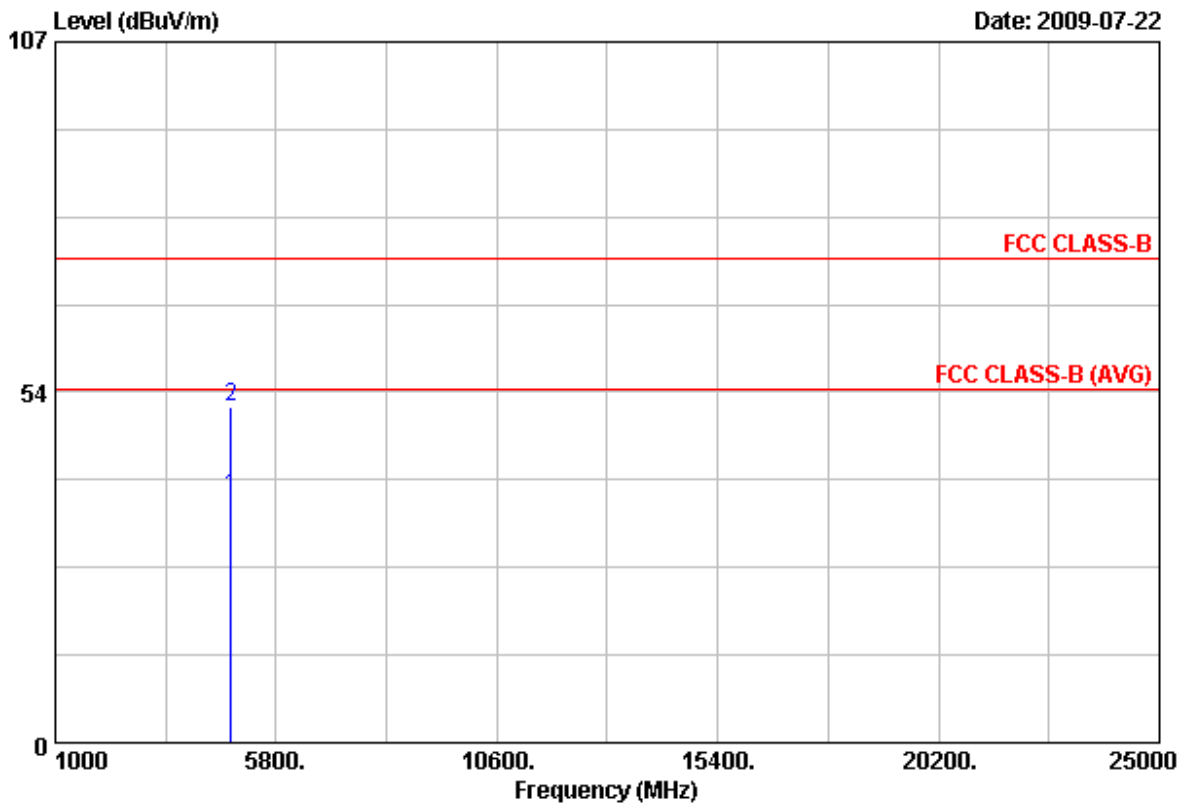

Item	Freq	Read Value	Factor	Result	Limit	Margin	Remark	Ant Pos	Tab Pos
	MHz	dBuV/m	dB	dBuV/m	dBuV/m	dB		cm	Deg
1	4823.70	32.20	5.33	37.53	54.00	-16.47	Average	100	0
2	4824.75	45.89	5.33	51.22	74.00	-22.78	Peak	100	0

Notes:

1. Result = Read Value + Factor
2. Factor = Antenna Factor + Cable Loss - Amplifier
3. The resolution bandwidth of test receiver/spectrum analyzer is 120KHz and video bandwidth is 300kHz for Peak detection and Quasi-peak detection at frequency below 1GHz.
4. The resolution bandwidth of test receiver/spectrum analyzer is 1MHz and video bandwidth is 3MHz for Peak detection at frequency above 1GHz.
5. The resolution bandwidth of test receiver/spectrum analyzer is 1MHz and video bandwidth is 10Hz for Average detection at frequency above 1GHz.
6. The other emissions is too low to be measured.



Power	: AC 120V	Pol/Phase	: VERTICAL
Test Mode 2	: Transmit / Receive	Temperature	: 26 °C
Operation Channel	: 6	Humidity	: 58 %
Modulation Type	: 802.11g	Atmospheric Pressure	: 1023 hPa
Memo	: Adapter: AD661F0916BLF	Rate	: 6 Mbps

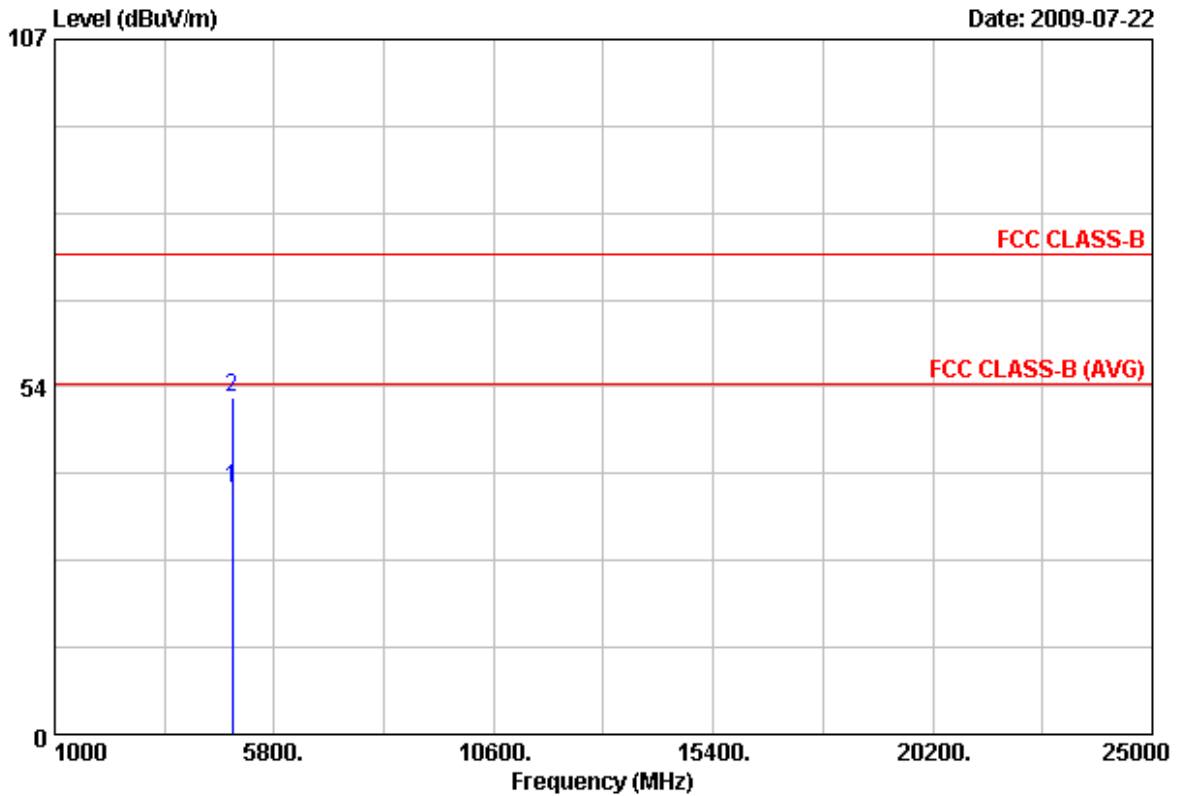

Item	Freq	Read Value	Factor	Result	Limit	Margin	Remark	Ant Pos	Tab Pos
	MHz	dBuV/m	dB	dBuV/m	dBuV/m	dB		cm	Deg
1	4873.65	32.50	5.49	37.99	54.00	-16.01	Average	100	325
2	4876.95	46.39	5.51	51.90	74.00	-22.10	Peak	100	205

Notes:

1. Result = Read Value + Factor
2. Factor = Antenna Factor + Cable Loss - Amplifier
3. The resolution bandwidth of test receiver/spectrum analyzer is 120KHz and video bandwidth is 300kHz for Peak detection and Quasi-peak detection at frequency below 1GHz.
4. The resolution bandwidth of test receiver/spectrum analyzer is 1MHz and video bandwidth is 3MHz for Peak detection at frequency above 1GHz.
5. The resolution bandwidth of test receiver/spectrum analyzer is 1MHz and video bandwidth is 10Hz for Average detection at frequency above 1GHz.
6. The other emissions is too low to be measured.



Power	: AC 120V	Pol/Phase	: HORIZONTAL
Test Mode 2	: Transmit / Receive	Temperature	: 26 °C
Operation Channel	: 6	Humidity	: 58 %
Modulation Type	: 802.11g	Atmospheric Pressure	: 1023 hPa
Memo	: Adapter: AD661F0916BLF	Rate	: 6 Mbps

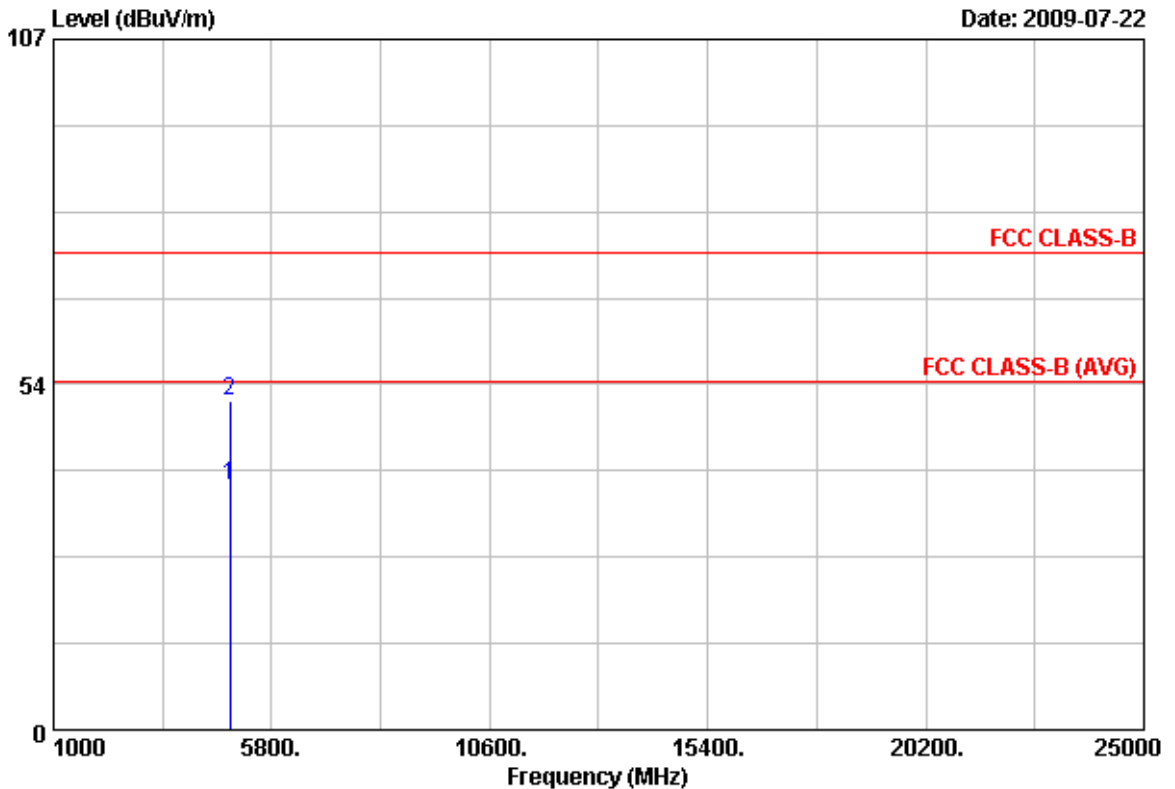

Item	Freq	Read Value	Factor	Result	Limit	Margin	Remark	Ant Pos	Tab Pos
	MHz	dBuV/m	dB	dBuV/m	dBuV/m	dB		cm	Deg
1	4873.40	32.27	5.49	37.76	54.00	-16.24	Average	100	0
2	4874.55	45.51	5.49	51.00	74.00	-23.00	Peak	100	0

Notes:

1. Result = Read Value + Factor
2. Factor = Antenna Factor + Cable Loss - Amplifier
3. The resolution bandwidth of test receiver/spectrum analyzer is 120KHz and video bandwidth is 300kHz for Peak detection and Quasi-peak detection at frequency below 1GHz.
4. The resolution bandwidth of test receiver/spectrum analyzer is 1MHz and video bandwidth is 3MHz for Peak detection at frequency above 1GHz.
5. The resolution bandwidth of test receiver/spectrum analyzer is 1MHz and video bandwidth is 10Hz for Average detection at frequency above 1GHz.
6. The other emissions is too low to be measured.



Power	: AC 120V	Pol/Phase	: VERTICAL
Test Mode 2	: Transmit / Receive	Temperature	: 26 °C
Operation Channel	: 11	Humidity	: 58 %
Modulation Type	: 802.11g	Atmospheric Pressure	: 1023 hPa
Memo	: Adapter: AD661F0916BLF	Rate	: 6 Mbps

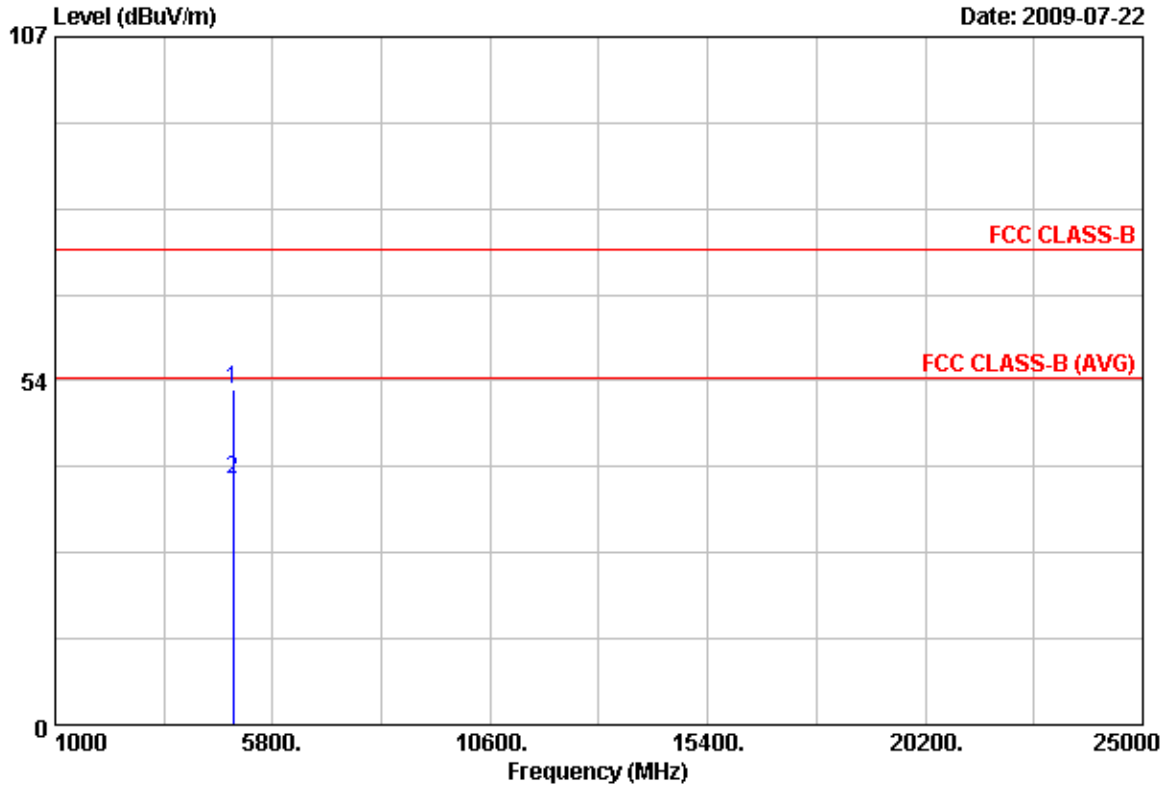

Item	Freq	Read Value	Factor	Result	Limit	Margin	Remark	Ant Pos	Tab Pos
	MHz	dBuV/m	dB	dBuV/m	dBuV/m	dB		cm	Deg
1	4923.25	46.40	5.65	52.05	74.00	-21.95	Peak	100	360
2	4925.75	32.46	5.67	38.13	54.00	-15.87	Average	100	360

## Notes:

1. Result = Read Value + Factor
2. Factor = Antenna Factor + Cable Loss - Amplifier
3. The resolution bandwidth of test receiver/spectrum analyzer is 120KHz and video bandwidth is 300kHz for Peak detection and Quasi-peak detection at frequency below 1GHz.
4. The resolution bandwidth of test receiver/spectrum analyzer is 1MHz and video bandwidth is 3MHz for Peak detection at frequency above 1GHz.
5. The resolution bandwidth of test receiver/spectrum analyzer is 1MHz and video bandwidth is 10Hz for Average detection at frequency above 1GHz.
6. The other emissions is too low to be measured.



Power	: AC 120V	Pol/Phase	: HORIZONTAL
Test Mode 2	: Transmit / Receive	Temperature	: 26 °C
Operation Channel	: 11	Humidity	: 58 %
Modulation Type	: 802.11g	Atmospheric Pressure	: 1023 hPa
Memo	: Adapter: AD661F0916BLF	Rate	: 6 Mbps

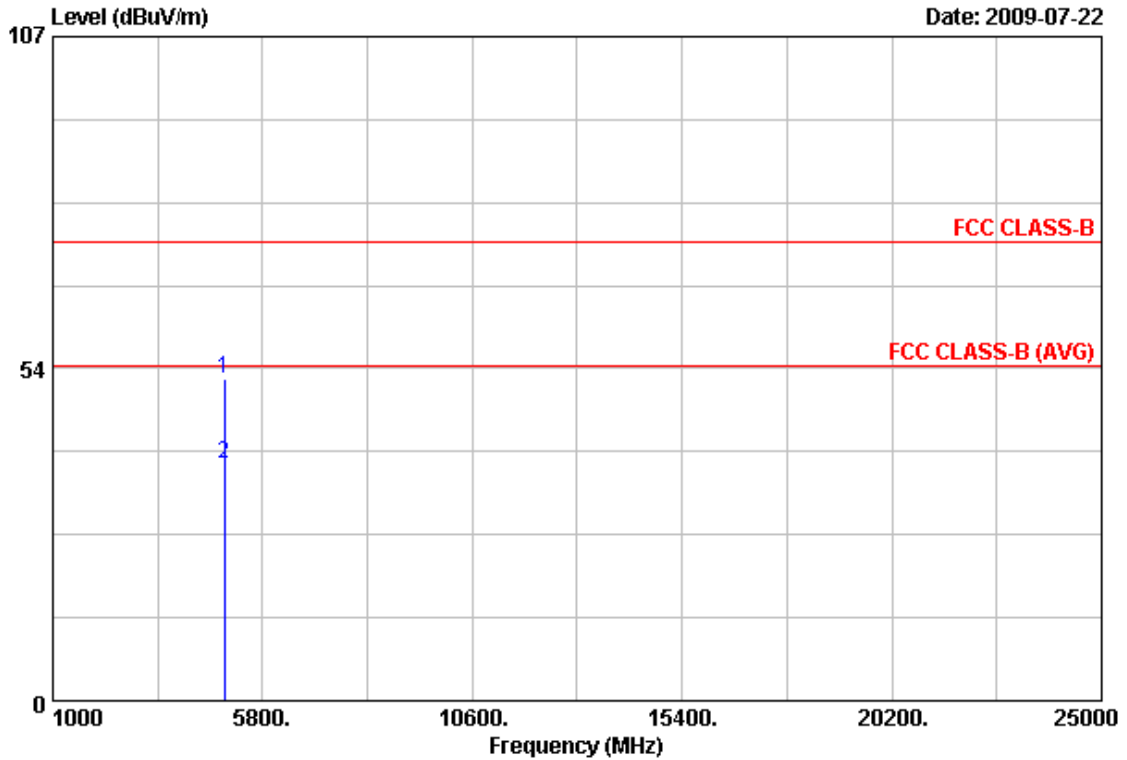

Item	Freq	Read Value	Factor	Result	Limit	Margin	Remark	Ant Pos	Tab Pos
	MHz	dBuV/m	dB	dBuV/m	dBuV/m	dB		cm	Deg
1	4922.95	46.14	5.65	51.79	74.00	-22.21	Peak	100	0
2	4925.10	32.45	5.67	38.12	54.00	-15.88	Average	100	0

Notes:

1. Result = Read Value + Factor
2. Factor = Antenna Factor + Cable Loss - Amplifier
3. The resolution bandwidth of test receiver/spectrum analyzer is 120KHz and video bandwidth is 300kHz for Peak detection and Quasi-peak detection at frequency below 1GHz.
4. The resolution bandwidth of test receiver/spectrum analyzer is 1MHz and video bandwidth is 3MHz for Peak detection at frequency above 1GHz.
5. The resolution bandwidth of test receiver/spectrum analyzer is 1MHz and video bandwidth is 10Hz for Average detection at frequency above 1GHz.
6. The other emissions is too low to be measured.





Power	: AC 120V	Pol/Phase	: VERTICAL
Test Mode 2	: Transmit / Receive	Temperature	: 26 °C
Operation Channel	: 1	Humidity	: 58 %
Modulation Type	: 802.11n, HT20	Atmospheric Pressure	: 1023 hPa
Memo	: Adapter: AD661F0916BLF	Rate	: 6.5Mbps

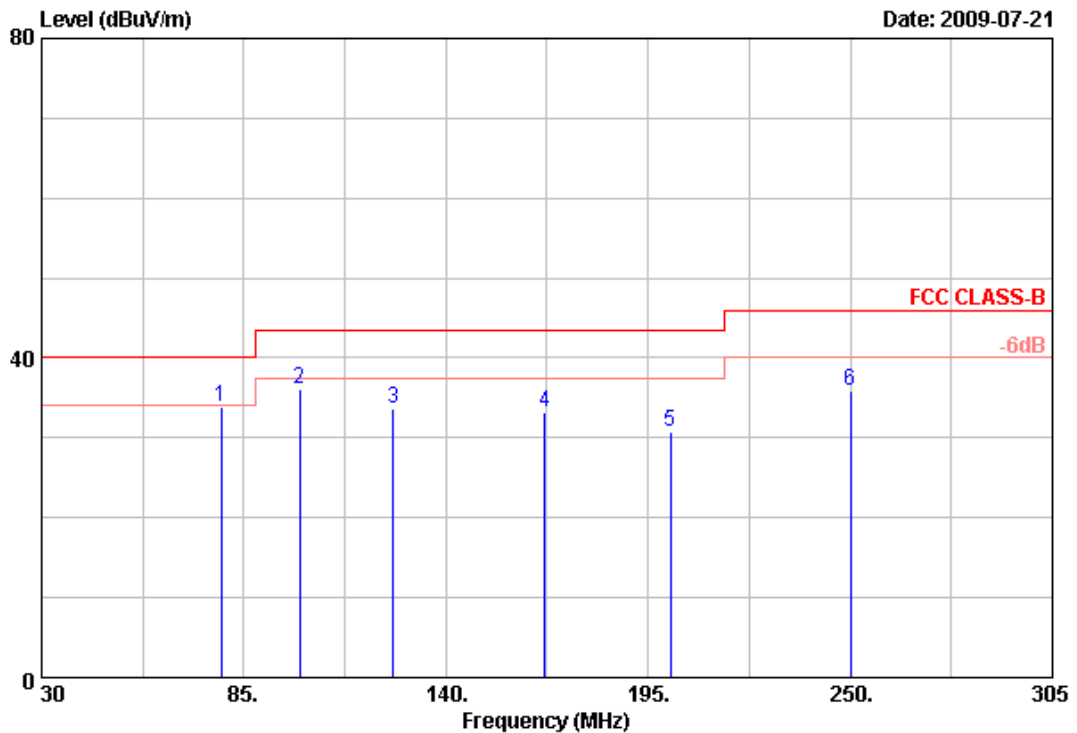

Item	Freq	Read Value	Factor	Result	Limit	Margin	Remark	Ant Pos	Tab Pos
	MHz	dBUV/m	dB	dBUV/m	dBUV/m	dB		cm	Deg
1	78.95	48.39	-14.51	33.88	40.00	-6.12	Peak	100	360
2	100.13	47.66	-11.62	36.04	43.50	-7.46	Peak	100	360
3	125.70	43.03	-9.31	33.72	43.50	-9.78	Peak	100	360
4	166.95	45.32	-12.12	33.20	43.50	-10.30	Peak	100	360
5	201.05	40.15	-9.43	30.72	43.50	-12.78	Peak	100	360
6	250.00	48.58	-12.64	35.94	46.00	-10.06	Peak	100	360

Notes:

1. Result = Read Value + Factor
2. Factor = Antenna Factor + Cable Loss - Amplifier
3. The resolution bandwidth of test receiver/spectrum analyzer is 120KHz and video bandwidth is 300KHz for Peak detection and Quasi-peak detection at frequency below 1GHz.
4. According to technical experiences, all spurious emission of 802.11MIMO mode at channel 1,6,11 are almost the same below 1GHz, so that the channel 1 was chosen as representative in final test.
5. The data is worse case.



Power	: AC 120V	Pol/Phase	: VERTICAL
Test Mode 2	: Transmit / Receive	Temperature	: 26 °C
Operation Channel	: 1	Humidity	: 58 %
Modulation Type	: 802.11n, HT20	Atmospheric Pressure	: 1023 hPa
Memo	: Adapter: AD661F0916BLF	Rate	: 6.5Mbps

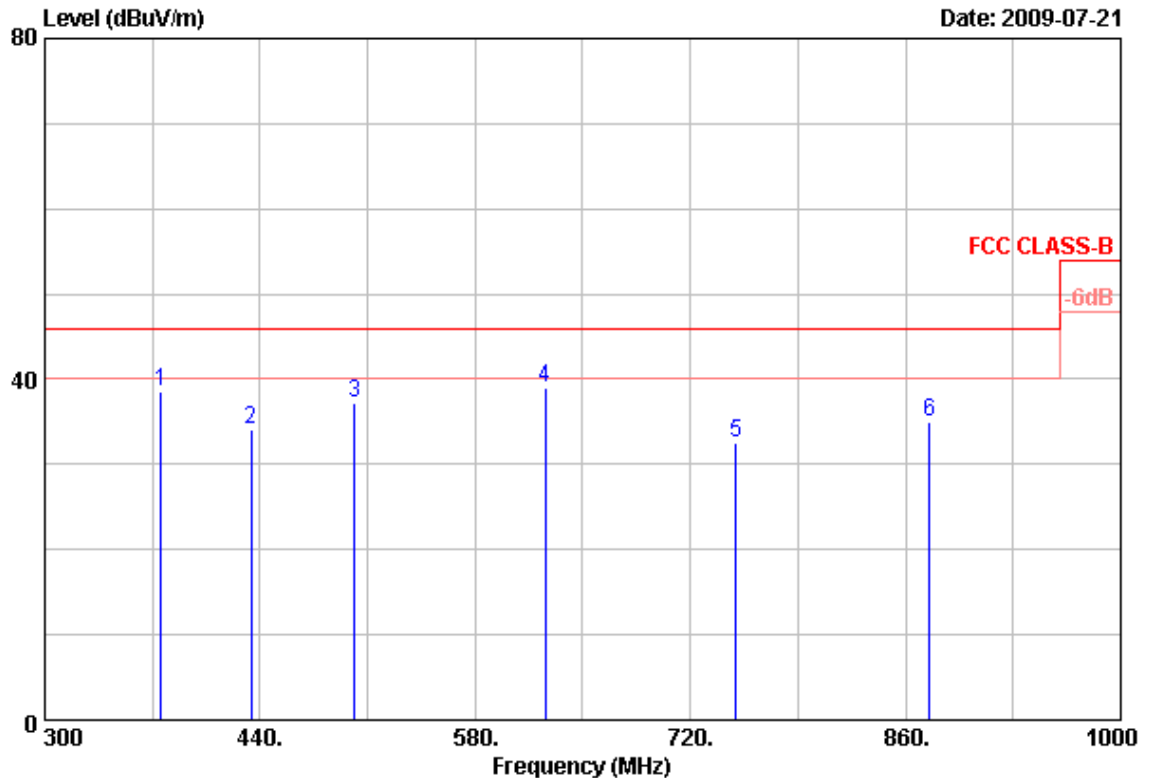

Item	Freq	Read Value	Factor	Result	Limit	Margin	Remark	Ant Pos	Tab Pos
	MHz	dBUV/m	dB	dBUV/m	dBUV/m	dB		cm	Deg
1	375.60	48.80	-10.31	38.49	46.00	-7.51	Peak	100	0
2	434.40	41.49	-7.30	34.19	46.00	-11.81	Peak	100	0
3	501.60	45.66	-8.44	37.22	46.00	-8.78	Peak	100	0
4	625.50	45.48	-6.52	38.96	46.00	-7.04	Peak	100	0
5	749.40	33.42	-0.91	32.51	46.00	-13.49	Peak	100	0
6	875.40	34.16	0.75	34.91	46.00	-11.09	Peak	100	0

Notes:

1. Result = Read Value + Factor
2. Factor = Antenna Factor + Cable Loss - Amplifier
3. The resolution bandwidth of test receiver/spectrum analyzer is 120KHz and video bandwidth is 300kHz for Peak detection and Quasi-peak detection at frequency below 1GHz.
4. According to technical experiences, all spurious emission of 802.11MIMO mode at channel 1, 6, 11 are almost the same below 1GHz, so that the channel 1 was chosen as representative in final test.
5. The data is worse case.



Power	: AC 120V	Pol/Phase	: HORIZONTAL
Test Mode 2	: Transmit / Receive	Temperature	: 26 °C
Operation Channel	: 1	Humidity	: 58 %
Modulation Type	: 802.11n, HT20	Atmospheric Pressure	: 1023 hPa
Memo	: Adapter: AD661F0916BLF	Rate	: 6.5Mbps

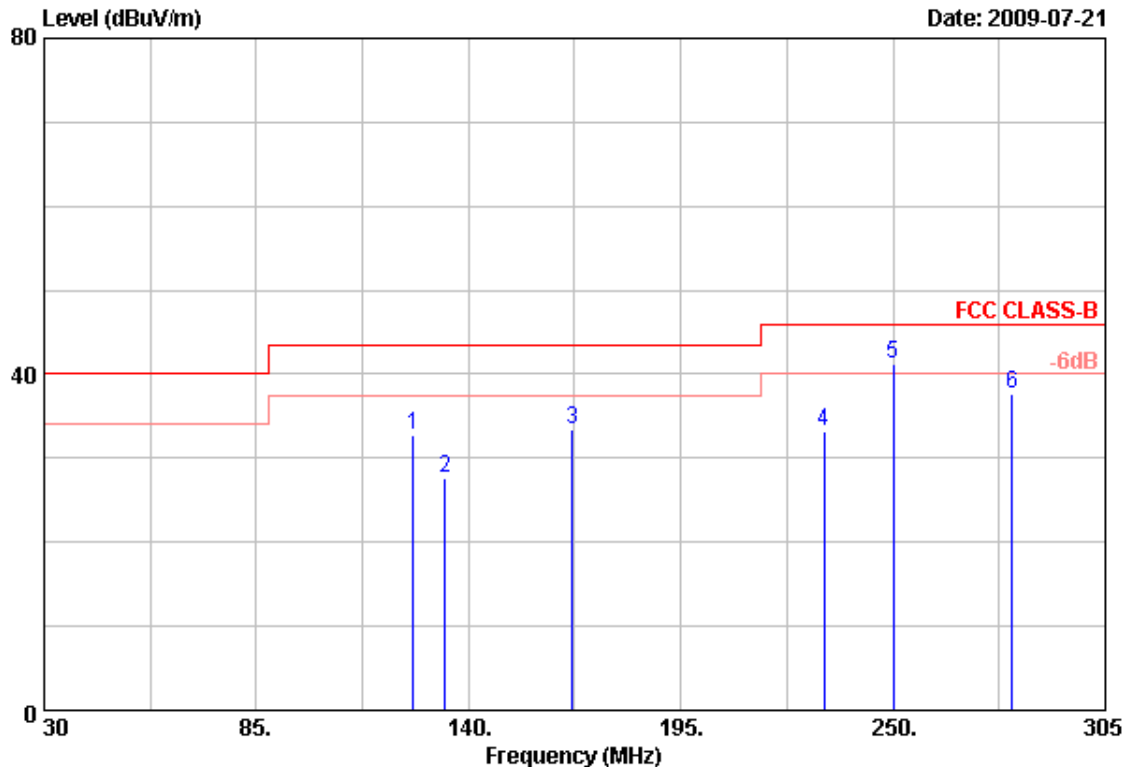

Item	Freq	Read Value	Factor	Result	Limit	Margin	Remark	Ant Pos	Tab Pos
	MHz	dBuV/m	dB	dBuV/m	dBuV/m	dB		cm	Deg
1	125.70	49.48	-16.64	32.84	43.50	-10.66	Peak	100	360
2	133.95	44.49	-16.76	27.73	43.50	-15.77	Peak	100	360
3	166.95	50.64	-17.25	33.39	43.50	-10.11	Peak	100	360
4	232.13	49.32	-16.12	33.20	46.00	-12.80	Peak	100	360
5	250.00	56.53	-15.28	41.25	46.00	-4.75	QP	100	360
6	280.80	50.98	-13.24	37.74	46.00	-8.26	Peak	100	360

## Notes:

1. Result = Read Value + Factor
2. Factor = Antenna Factor + Cable Loss - Amplifier
3. The resolution bandwidth of test receiver/spectrum analyzer is 120KHz and video bandwidth is 300kHz for Peak detection and Quasi-peak detection at frequency below 1GHz.
4. According to technical experiences, all spurious emission of 802.11MIMO mode at channel 1,6,11 are almost the same below 1GHz, so that the channel 1 was chosen as representative in final test.
5. The data is worse case.



Power	: AC 120V	Pol/Phase	: HORIZONTAL
Test Mode 2	: Transmit / Receive	Temperature	: 26 °C
Operation Channel	: 1	Humidity	: 58 %
Modulation Type	: 802.11n, HT20	Atmospheric Pressure	: 1023 hPa
Memo	: Adapter: AD661F0916BLF	Rate	: 6.5Mbps

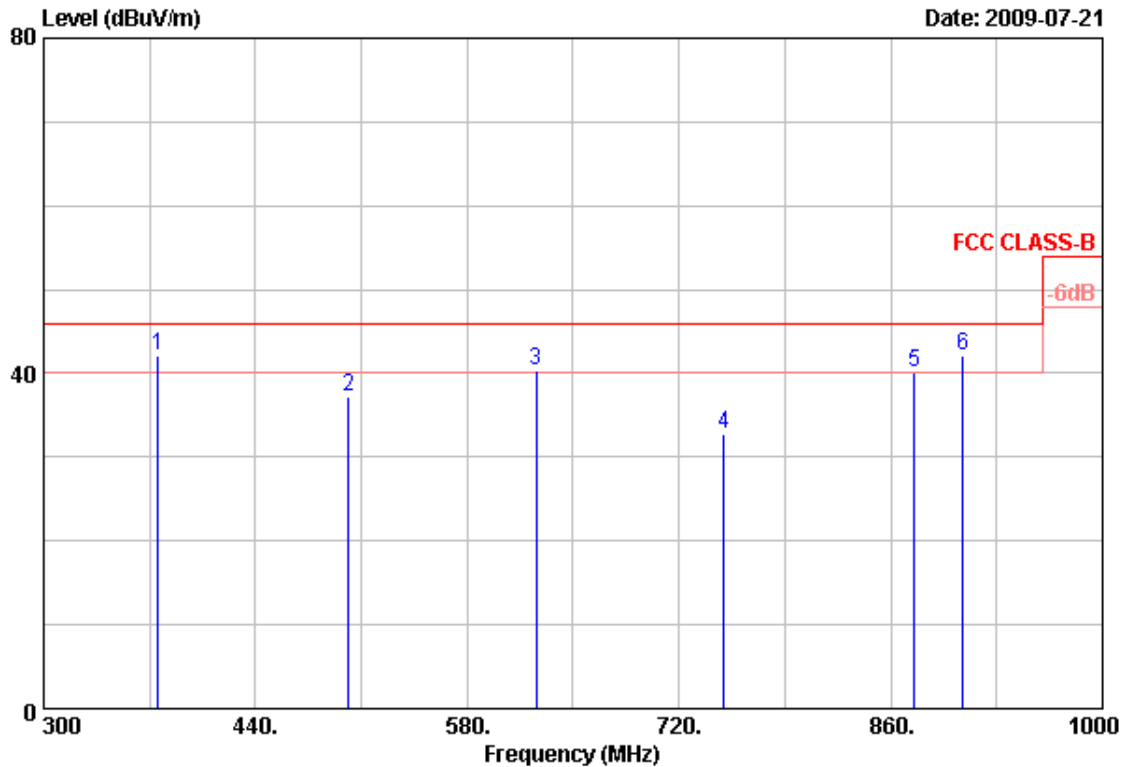

Item	Freq	Read Value	Factor	Result	Limit	Margin	Remark	Ant Pos	Tab Pos
	MHz	dBuV/m	dB	dBuV/m	dBuV/m	dB		cm	Deg
1	375.60	53.86	-11.68	42.18	46.00	-3.82	QP	100	0
2	501.60	42.54	-5.42	37.12	46.00	-8.88	Peak	100	0
3	625.50	41.78	-1.45	40.33	46.00	-5.67	QP	100	0
4	749.40	34.55	-1.85	32.70	46.00	-13.30	Peak	100	0
5	875.40	39.99	0.06	40.05	46.00	-5.95	QP	100	0
6	907.60	39.70	2.35	42.05	46.00	-3.95	QP	100	0

Notes:

1. Result = Read Value + Factor
2. Factor = Antenna Factor + Cable Loss - Amplifier
3. The resolution bandwidth of test receiver/spectrum analyzer is 120KHz and video bandwidth is 300kHz for Peak detection and Quasi-peak detection at frequency below 1GHz.
4. According to technical experiences, all spurious emission of 802.11MIMO mode at channel 1,6,11 are almost the same below 1GHz, so that the channel 1 was chosen as representative in final test.
5. The data is worse case.



Power	: AC 120V	Pol/Phase	: VERTICAL
Test Mode 2	: Transmit / Receive	Temperature	: 26 °C
Operation Channel	: 1	Humidity	: 58 %
Modulation Type	: 802.11n, HT20	Atmospheric Pressure	: 1023 hPa
Memo	: Adapter: AD661F0916BLF	Rate	: 6.5Mbps

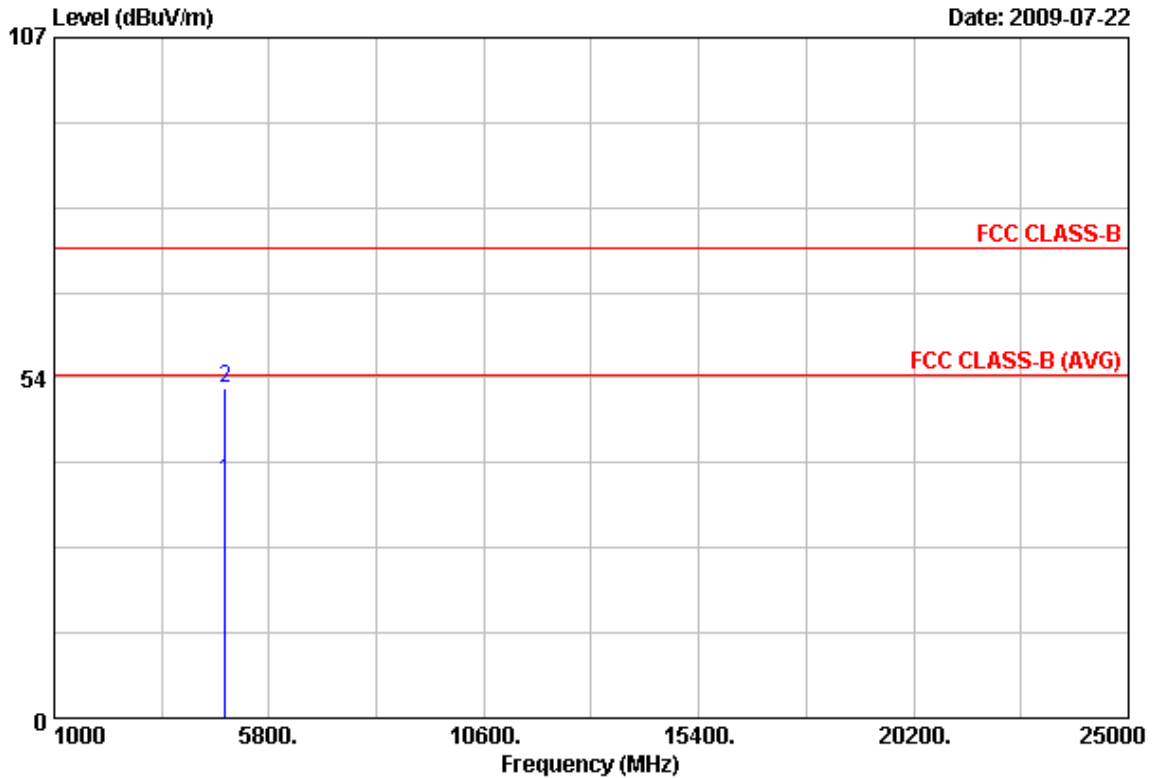

Item	Freq	Read Value	Factor	Result	Limit	Margin	Remark	Ant Pos	Tab Pos
	MHz	dBuV/m	dB	dBuV/m	dBuV/m	dB		cm	Deg
1	4823.65	31.96	5.33	37.29	54.00	-16.71	Average	100	0
2	4824.35	46.39	5.33	51.72	74.00	-22.28	Peak	100	0

## Notes:

1. Result = Read Value + Factor
2. Factor = Antenna Factor + Cable Loss - Amplifier
3. The resolution bandwidth of test receiver/spectrum analyzer is 120KHz and video bandwidth is 300kHz for Peak detection and Quasi-peak detection at frequency below 1GHz.
4. The resolution bandwidth of test receiver/spectrum analyzer is 1MHz and video bandwidth is 3MHz for Peak detection at frequency above 1GHz.
5. The resolution bandwidth of test receiver/spectrum analyzer is 1MHz and video bandwidth is 10Hz for Average detection at frequency above 1GHz.
6. The other emissions is too low to be measured.



Power	: AC 120V	Pol/Phase	: HORIZONTAL
Test Mode 2	: Transmit / Receive	Temperature	: 26 °C
Operation Channel	: 1	Humidity	: 58 %
Modulation Type	: 802.11n, HT20	Atmospheric Pressure	: 1023 hPa
Memo	: Adapter: AD661F0916BLF	Rate	: 6.5Mbps

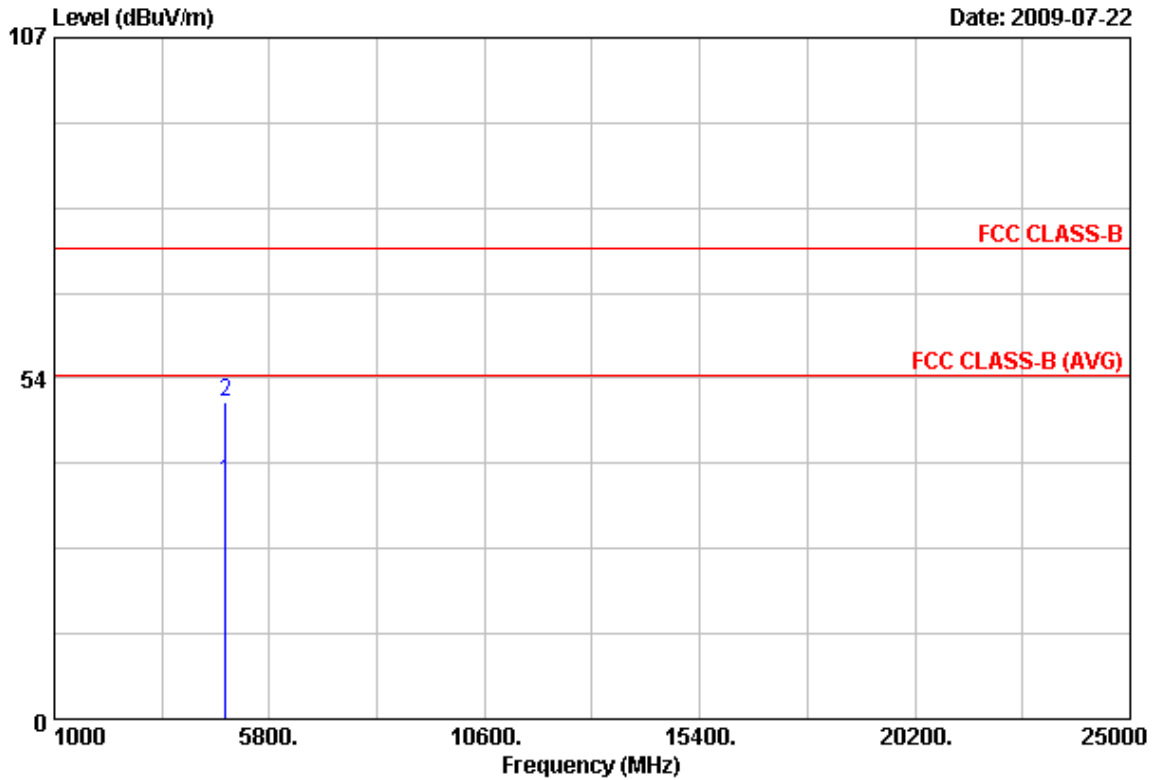

Item	Freq	Read Value	Factor	Result	Limit	Margin	Remark	Ant Pos	Tab Pos
	MHz	dBuV/m	dB	dBuV/m	dBuV/m	dB		cm	Deg
1	4823.60	32.01	5.33	37.34	54.00	-16.66	Average	100	0
2	4824.30	44.53	5.33	49.86	74.00	-24.14	Peak	100	0

Notes:

1. Result = Read Value + Factor
2. Factor = Antenna Factor + Cable Loss - Amplifier
3. The resolution bandwidth of test receiver/spectrum analyzer is 120KHz and video bandwidth is 300kHz for Peak detection and Quasi-peak detection at frequency below 1GHz.
4. The resolution bandwidth of test receiver/spectrum analyzer is 1MHz and video bandwidth is 3MHz for Peak detection at frequency above 1GHz.
5. The resolution bandwidth of test receiver/spectrum analyzer is 1MHz and video bandwidth is 10Hz for Average detection at frequency above 1GHz.
6. The other emissions is too low to be measured.



Power	: AC 120V	Pol/Phase	: VERTICAL
Test Mode 2	: Transmit / Receive	Temperature	: 26 °C
Operation Channel	: 6	Humidity	: 58 %
Modulation Type	: 802.11n, HT20	Atmospheric Pressure	: 1023 hPa
Memo	: Adapter: AD661F0916BLF	Rate	: 6.5Mbps

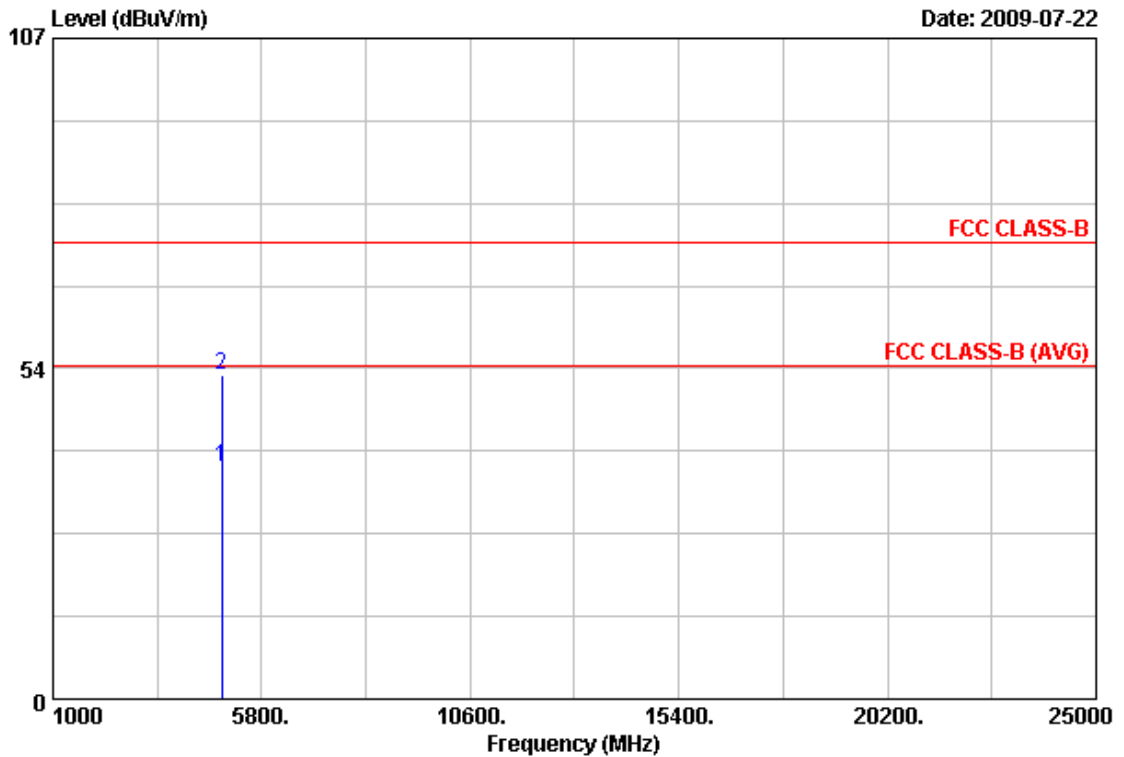

Item	Freq	Read Value	Factor	Result	Limit	Margin	Remark	Ant Pos	Tab Pos
	MHz	dBuV/m	dB	dBuV/m	dBuV/m	dB		cm	Deg
1	4873.05	31.99	5.49	37.48	54.00	-16.52	Average	100	0
2	4875.55	46.98	5.51	52.49	74.00	-21.51	Peak	100	0

Notes:

1. Result = Read Value + Factor
2. Factor = Antenna Factor + Cable Loss - Amplifier
3. The resolution bandwidth of test receiver/spectrum analyzer is 120KHz and video bandwidth is 300kHz for Peak detection and Quasi-peak detection at frequency below 1GHz.
4. The resolution bandwidth of test receiver/spectrum analyzer is 1MHz and video bandwidth is 3MHz for Peak detection at frequency above 1GHz.
5. The resolution bandwidth of test receiver/spectrum analyzer is 1MHz and video bandwidth is 10Hz for Average detection at frequency above 1GHz.
6. The other emissions is too low to be measured.



Power	: AC 120V	Pol/Phase	: HORIZONTAL
Test Mode 2	: Transmit / Receive	Temperature	: 26 °C
Operation Channel	: 6	Humidity	: 58 %
Modulation Type	: 802.11n, HT20	Atmospheric Pressure	: 1023 hPa
Memo	: Adapter: AD661F0916BLF	Rate	: 6.5Mbps

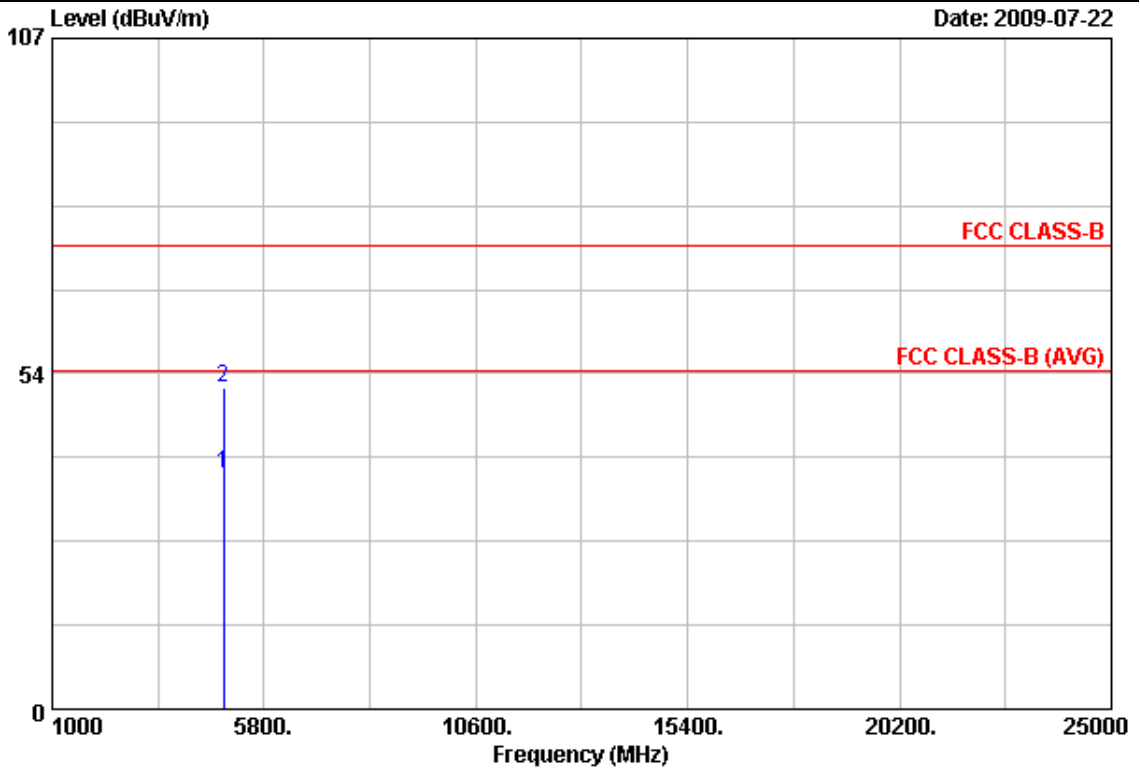

Item	Freq	Read Value	Factor	Result	Limit	Margin	Remark	Ant Pos	Tab Pos
	MHz	dBuV/m	dB	dBuV/m	dBuV/m	dB		cm	Deg
1	4873.40	32.04	5.49	37.53	54.00	-16.47	Average	100	0
2	4874.70	45.83	5.49	51.32	74.00	-22.68	Peak	100	0

Notes:

1. Result = Read Value + Factor
2. Factor = Antenna Factor + Cable Loss - Amplifier
3. The resolution bandwidth of test receiver/spectrum analyzer is 120KHz and video bandwidth is 300kHz for Peak detection and Quasi-peak detection at frequency below 1GHz.
4. The resolution bandwidth of test receiver/spectrum analyzer is 1MHz and video bandwidth is 3MHz for Peak detection at frequency above 1GHz.
5. The resolution bandwidth of test receiver/spectrum analyzer is 1MHz and video bandwidth is 10Hz for Average detection at frequency above 1GHz.
6. The other emissions is too low to be measured.





Power	: AC 120V	Pol/Phase	: VERTICAL
Test Mode 2	: Transmit / Receive	Temperature	: 26 °C
Operation Channel	: 11	Humidity	: 58 %
Modulation Type	: 802.11n, HT20	Atmospheric Pressure	: 1023 hPa
Memo	: Adapter: AD661F0916BLF	Rate	: 6.5Mbps

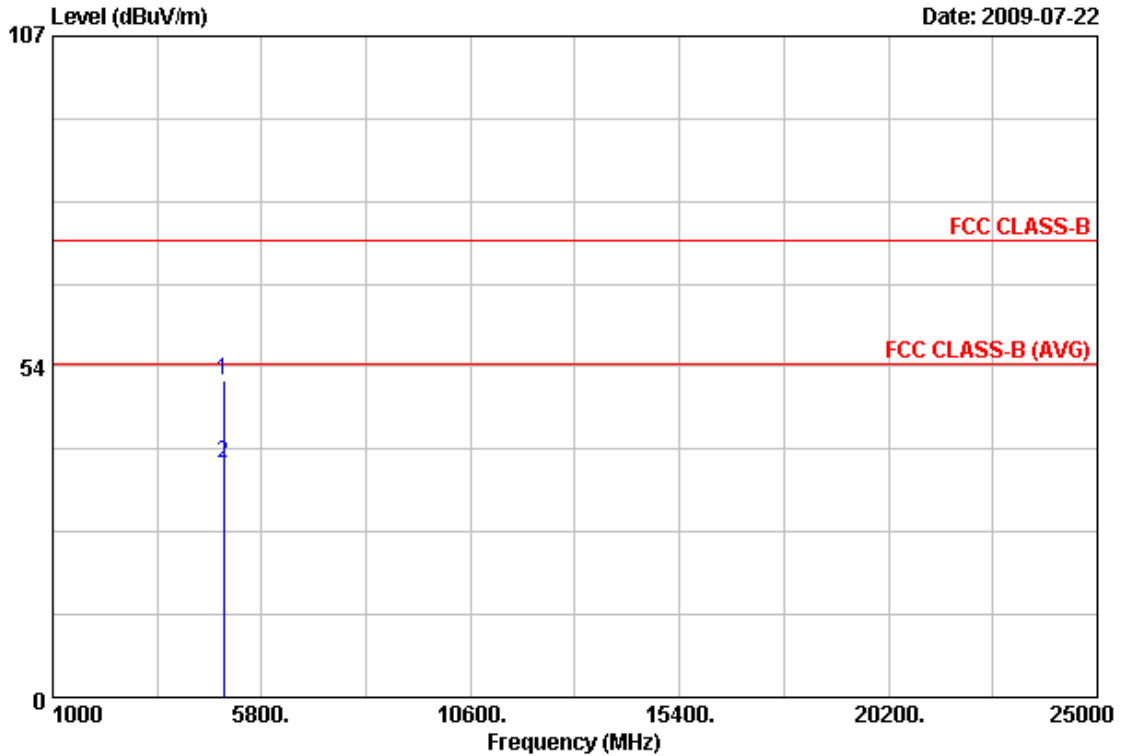

Item	Freq	Read Value	Factor	Result	Limit	Margin	Remark	Ant Pos	Tab Pos
	MHz	dBuV/m	dB	dBuV/m	dBuV/m	dB		cm	Deg
1	4920.80	45.65	5.64	51.29	74.00	-22.71	Peak	100	0
2	4924.90	32.11	5.65	37.76	54.00	-16.24	Average	100	0

Notes:

1. Result = Read Value + Factor
2. Factor = Antenna Factor + Cable Loss - Amplifier
3. The resolution bandwidth of test receiver/spectrum analyzer is 120kHz and video bandwidth is 300kHz for Peak detection and Quasi-peak detection at frequency below 1GHz.
4. The resolution bandwidth of test receiver/spectrum analyzer is 1MHz and video bandwidth is 3MHz for Peak detection at frequency above 1GHz.
5. The resolution bandwidth of test receiver/spectrum analyzer is 1MHz and video bandwidth is 10Hz for Average detection at frequency above 1GHz.
6. The other emissions is too low to be measured.



Power	: AC 120V	Pol/Phase	: HORIZONTAL
Test Mode 2	: Transmit / Receive	Temperature	: 26 °C
Operation Channel	: 11	Humidity	: 58 %
Modulation Type	: 802.11n, HT20	Atmospheric Pressure	: 1023 hPa
Memo	: Adapter: AD661F0916BLF	Rate	: 6.5Mbps

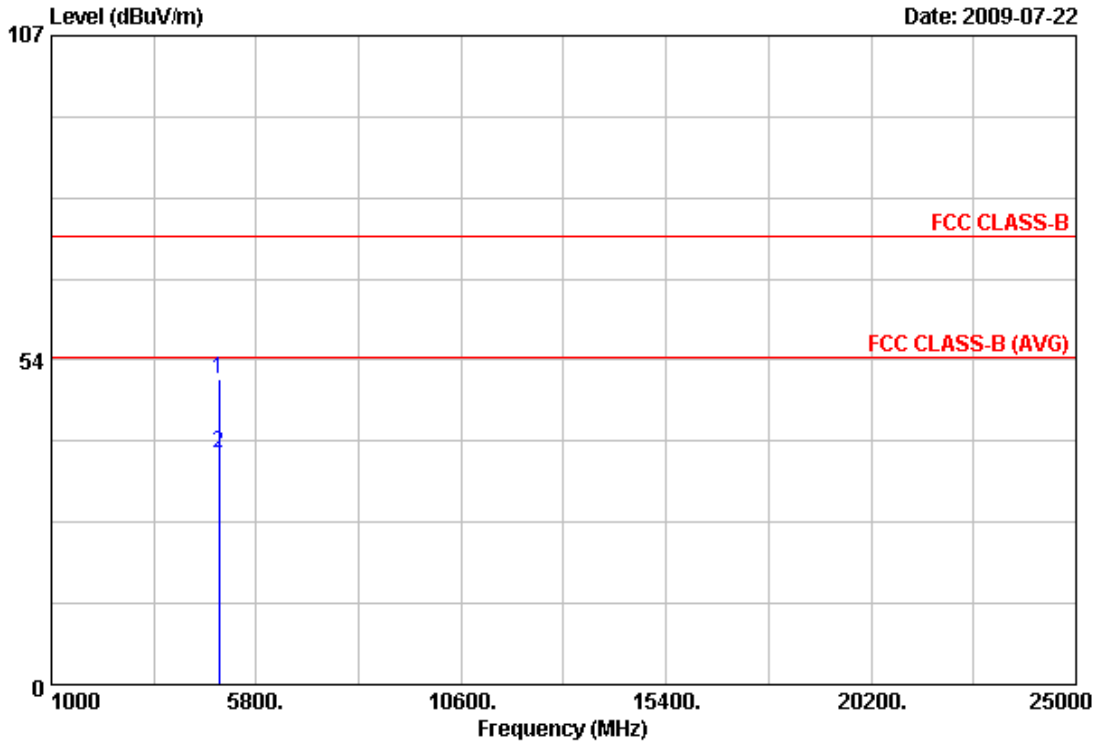

Item	Freq	Read Value	Factor	Result	Limit	Margin	Remark	Ant Pos	Tab Pos
	MHz	dBuV/m	dB	dBuV/m	dBuV/m	dB		cm	Deg
1	4923.00	44.80	5.65	50.45	74.00	-23.55	Peak	100	0
2	4923.40	32.49	5.65	38.14	54.00	-15.86	Average	100	0

Notes:

1. Result = Read Value + Factor
2. Factor = Antenna Factor + Cable Loss - Amplifier
3. The resolution bandwidth of test receiver/spectrum analyzer is 120KHz and video bandwidth is 300kHz for Peak detection and Quasi-peak detection at frequency below 1GHz.
4. The resolution bandwidth of test receiver/spectrum analyzer is 1MHz and video bandwidth is 3MHz for Peak detection at frequency above 1GHz.
5. The resolution bandwidth of test receiver/spectrum analyzer is 1MHz and video bandwidth is 10Hz for Average detection at frequency above 1GHz.
6. The other emissions is too low to be measured.



Power	: AC 120V	Pol/Phase	: VERTICAL
Test Mode 2	: Transmit / Receive	Temperature	: 26 °C
Operation Channel	: 3	Humidity	: 58 %
Modulation Type	: 802.11n, HT40	Atmospheric Pressure	: 1023 hPa
Memo	: Adapter: AD661F0916BLF	Rate	: 13.5Mbps

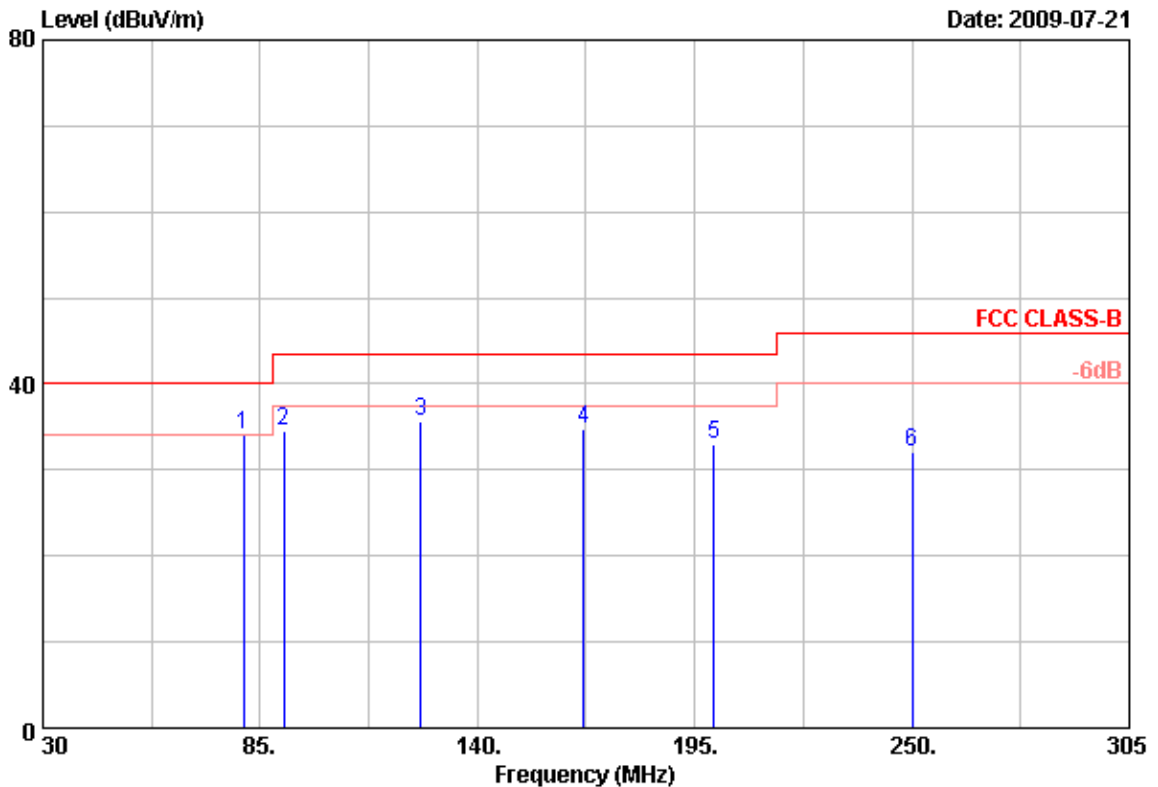

Item	Freq	Read Value	Factor	Result	Limit	Margin	Remark	Ant Pos	Tab Pos
	MHz	dBuV/m	dB	dBuV/m	dBuV/m	dB		cm	Deg
1	80.88	48.28	-14.22	34.06	40.00	-5.94	QP	100	360
2	91.05	47.17	-12.53	34.64	43.50	-8.86	Peak	100	360
3	125.70	44.89	-9.31	35.58	43.50	-7.92	Peak	100	360
4	166.95	46.94	-12.12	34.82	43.50	-8.68	Peak	100	360
5	199.95	42.48	-9.51	32.97	43.50	-10.53	Peak	100	360
6	250.00	44.77	-12.64	32.13	46.00	-13.87	Peak	100	360

Notes:

1. Result = Read Value + Factor
2. Factor = Antenna Factor + Cable Loss - Amplifier
3. The resolution bandwidth of test receiver/spectrum analyzer is 120KHz and video bandwidth is 300kHz for Peak detection and Quasi-peak detection at frequency below 1GHz.
4. According to technical experiences, all spurious emission of 802.11MIMO mode at channel 3,6,9 are almost the same below 1GHz, so that the channel 3 was chosen as representative in final test.
5. The data is worse case.



Power	: AC 120V	Pol/Phase	: VERTICAL
Test Mode 2	: Transmit / Receive	Temperature	: 26 °C
Operation Channel	: 3	Humidity	: 58 %
Modulation Type	: 802.11n, HT40	Atmospheric Pressure	: 1023 hPa
Memo	: Adapter: AD661F0916BLF	Rate	: 13.5Mbps

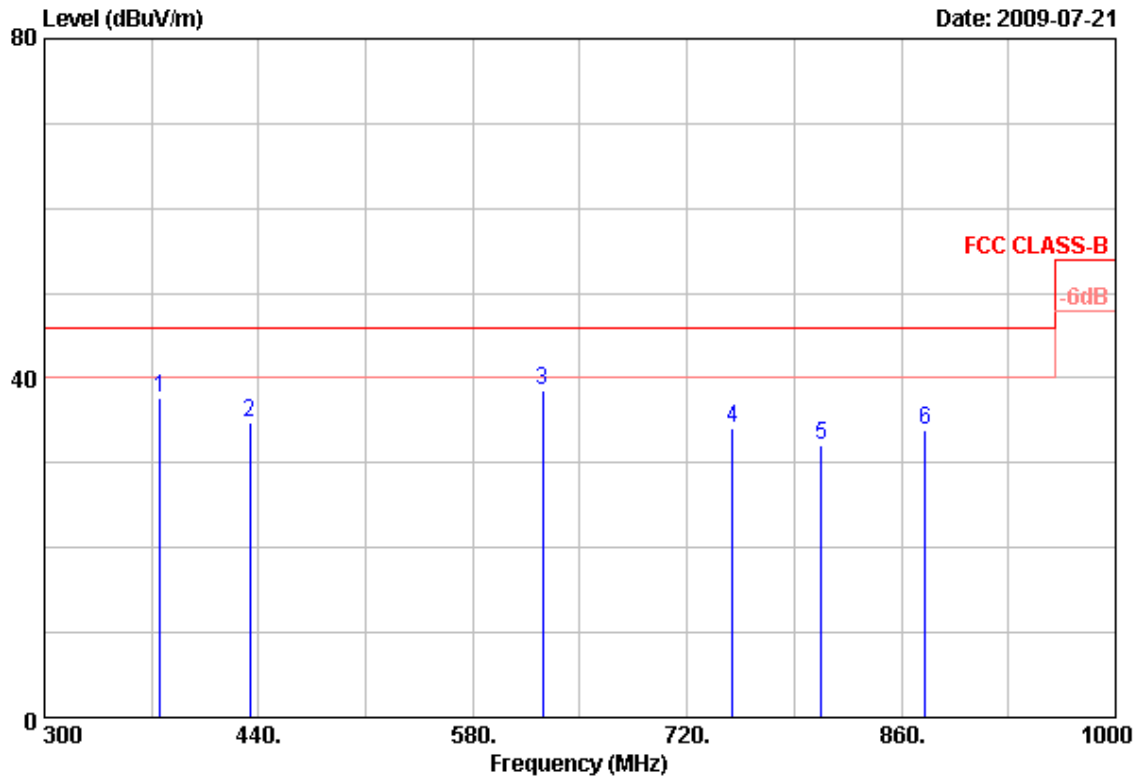

Item	Freq	Read Value	Factor	Result	Limit	Margin	Remark	Ant Pos	Tab Pos
	MHz	dBuV/m	dB	dBuV/m	dBuV/m	dB		cm	Deg
1	375.60	47.93	-10.31	37.62	46.00	-8.38	Peak	100	0
2	434.40	42.03	-7.30	34.73	46.00	-11.27	Peak	100	0
3	625.50	45.10	-6.52	38.58	46.00	-7.42	Peak	100	0
4	749.40	35.06	-0.91	34.15	46.00	-11.85	Peak	100	0
5	807.50	33.15	-1.13	32.02	46.00	-13.98	Peak	100	0
6	875.40	33.14	0.75	33.89	46.00	-12.11	Peak	100	0

## Notes:

1. Result = Read Value + Factor
2. Factor = Antenna Factor + Cable Loss - Amplifier
3. The resolution bandwidth of test receiver/spectrum analyzer is 120KHz and video bandwidth is 300kHz for Peak detection and Quasi-peak detection at frequency below 1GHz.
4. According to technical experiences, all spurious emission of 802.11MIMO mode at channel 3,6,9 are almost the same below 1GHz, so that the channel 3 was chosen as representative in final test.
5. The data is worse case.



Power	: AC 120V	Pol/Phase	: HORIZONTAL
Test Mode 2	: Transmit / Receive	Temperature	: 26 °C
Operation Channel	: 3	Humidity	: 58 %
Modulation Type	: 802.11n, HT40	Atmospheric Pressure	: 1023 hPa
Memo	: Adapter: AD661F0916BLF	Rate	: 13.5Mbps

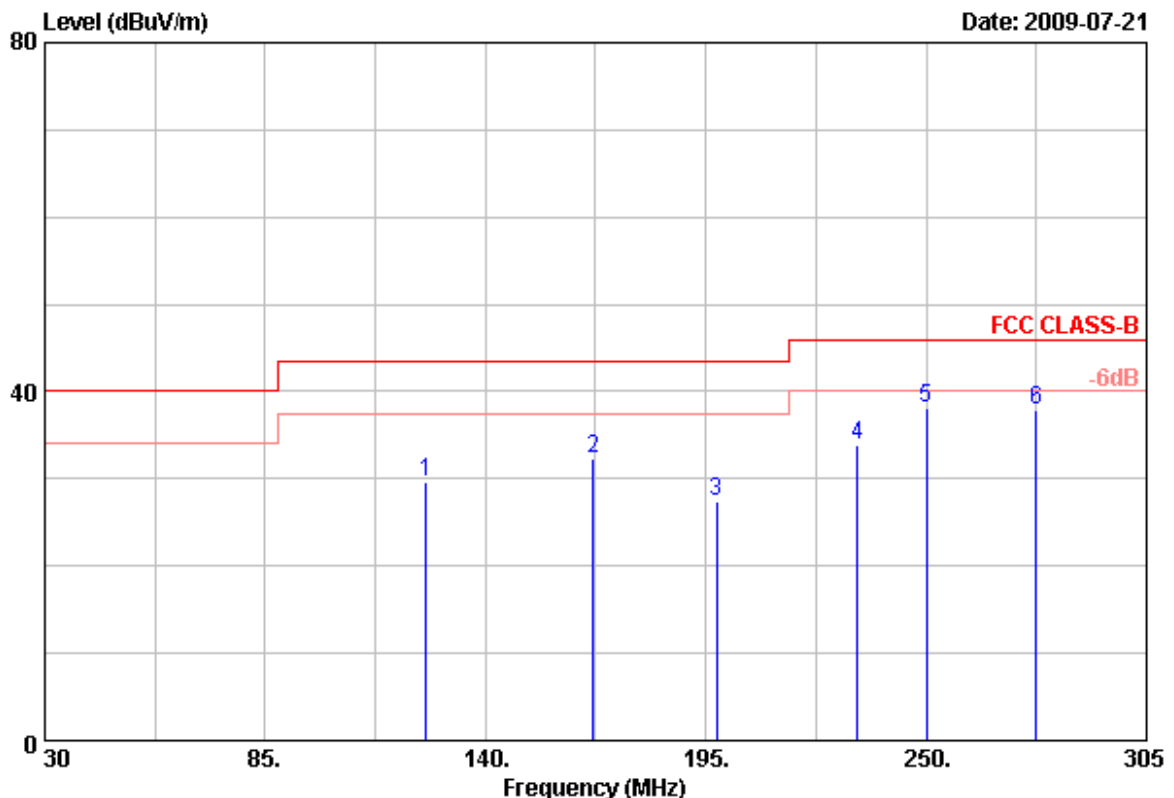

Item	Freq	Read Value	Factor	Result	Limit	Margin	Remark	Ant Pos	Tab Pos
	MHz	dBuV/m	dB	dBuV/m	dBuV/m	dB		cm	Deg
1	125.15	46.26	-16.66	29.60	43.50	-13.90	Peak	100	360
2	166.95	49.66	-17.25	32.41	43.50	-11.09	Peak	100	360
3	197.75	45.05	-17.60	27.45	43.50	-16.05	Peak	100	360
4	232.95	49.96	-16.11	33.85	46.00	-12.15	Peak	100	360
5	250.00	53.45	-15.28	38.17	46.00	-7.83	Peak	100	360
6	277.50	51.13	-13.21	37.92	46.00	-8.08	Peak	100	360

## Notes:

1. Result = Read Value + Factor
2. Factor = Antenna Factor + Cable Loss - Amplifier
3. The resolution bandwidth of test receiver/spectrum analyzer is 120kHz and video bandwidth is 300kHz for Peak detection and Quasi-peak detection at frequency below 1GHz.
4. According to technical experiences, all spurious emission of 802.11MIMO mode at channel 3,6,9 are almost the same below 1GHz, so that the channel 3 was chosen as representative in final test.
5. The data is worse case.



Power	: AC 120V	Pol/Phase	: HORIZONTAL
Test Mode 2	: Transmit / Receive	Temperature	: 26 °C
Operation Channel	: 3	Humidity	: 58 %
Modulation Type	: 802.11n, HT40	Atmospheric Pressure	: 1023 hPa
Memo	: Adapter: AD661F0916BLF	Rate	: 13.5Mbps

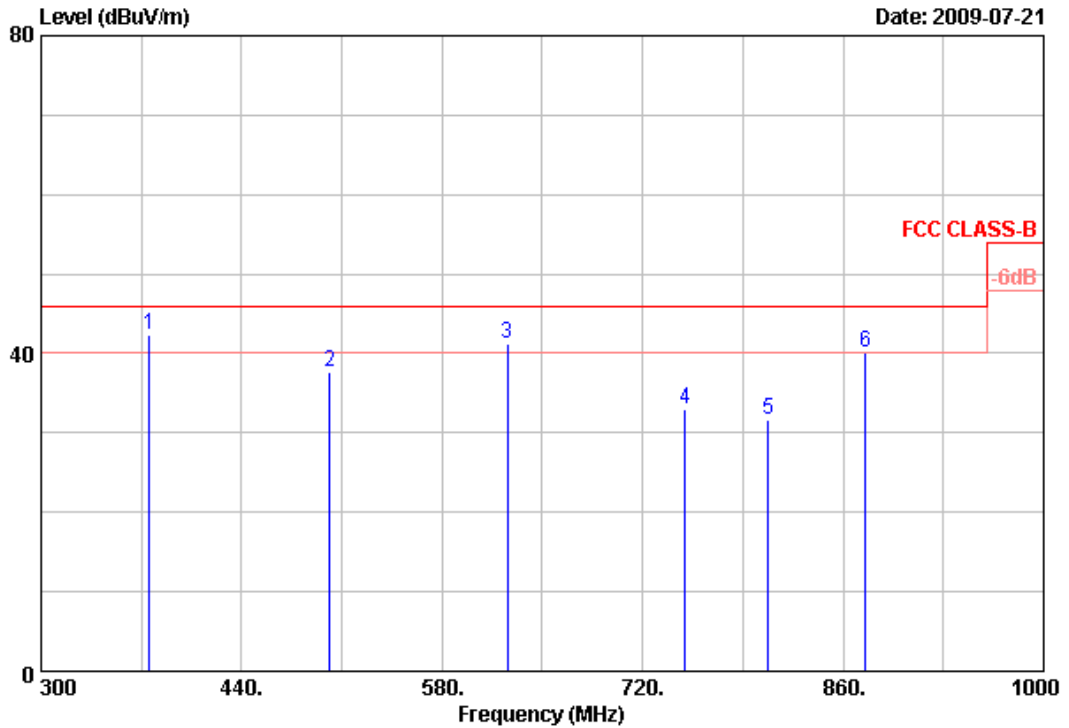

Item	Freq	Read Value	Factor	Result	Limit	Margin	Remark	Ant Pos	Tab Pos
	MHz	dBuV/m	dB	dBuV/m	dBuV/m	dB		cm	Deg
1	375.60	54.07	-11.68	42.39	46.00	-3.61	QP	100	0
2	501.60	42.97	-5.42	37.55	46.00	-8.45	Peak	100	0
3	625.50	42.74	-1.45	41.29	46.00	-4.71	QP	100	0
4	749.40	34.88	-1.85	33.03	46.00	-12.97	Peak	100	0
5	807.50	32.06	-0.51	31.55	46.00	-14.45	Peak	100	0
6	875.40	40.01	0.06	40.07	46.00	-5.93	QP	100	0

Notes:

1. Result = Read Value + Factor
2. Factor = Antenna Factor + Cable Loss - Amplifier
3. The resolution bandwidth of test receiver/spectrum analyzer is 120kHz and video bandwidth is 300kHz for Peak detection and Quasi-peak detection at frequency below 1GHz.
4. According to technical experiences, all spurious emission of 802.11MIMO mode at channel 3,6,9 are almost the same below 1GHz, so that the channel 3 was chosen as representative in final test.
5. The data is worse case.



Power	: AC 120V	Pol/Phase	: VERTICAL
Test Mode 2	: Transmit / Receive	Temperature	: 26 °C
Operation Channel	: 3	Humidity	: 58 %
Modulation Type	: 802.11n, HT40	Atmospheric Pressure	: 1023 hPa
Memo	: Adapter: AD661F0916BLF	Rate	: 13.5Mbps

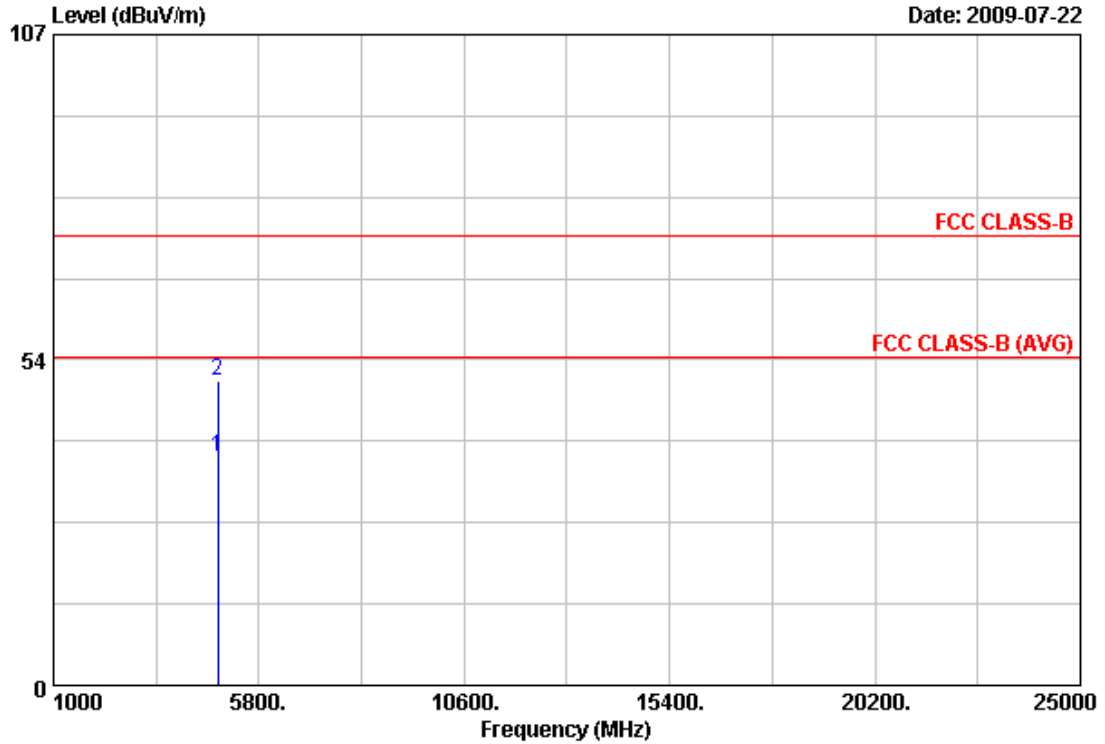

Item	Freq	Read Value	Factor	Result	Limit	Margin	Remark	Ant Pos	Tab Pos
	MHz	dBuV/m	dB	dBuV/m	dBuV/m	dB		cm	Deg
1	4844.75	32.23	5.40	37.63	54.00	-16.37	Average	100	0
2	4844.95	44.55	5.40	49.95	74.00	-24.05	Peak	100	0

Notes:

1. Result = Read Value + Factor
2. Factor = Antenna Factor + Cable Loss - Amplifier
3. The resolution bandwidth of test receiver/spectrum analyzer is 120kHz and video bandwidth is 300kHz for Peak detection and Quasi-peak detection at frequency below 1GHz.
4. The resolution bandwidth of test receiver/spectrum analyzer is 1MHz and video bandwidth is 3MHz for Peak detection at frequency above 1GHz.
5. The resolution bandwidth of test receiver/spectrum analyzer is 1MHz and video bandwidth is 10Hz for Average detection at frequency above 1GHz.
6. The other emissions is too low to be measured.



Power	: AC 120V	Pol/Phase	: HORIZONTAL
Test Mode 2	: Transmit / Receive	Temperature	: 26 °C
Operation Channel	: 3	Humidity	: 58 %
Modulation Type	: 802.11n, HT40	Atmospheric Pressure	: 1023 hPa
Memo	: Adapter: AD661F0916BLF	Rate	: 13.5Mbps

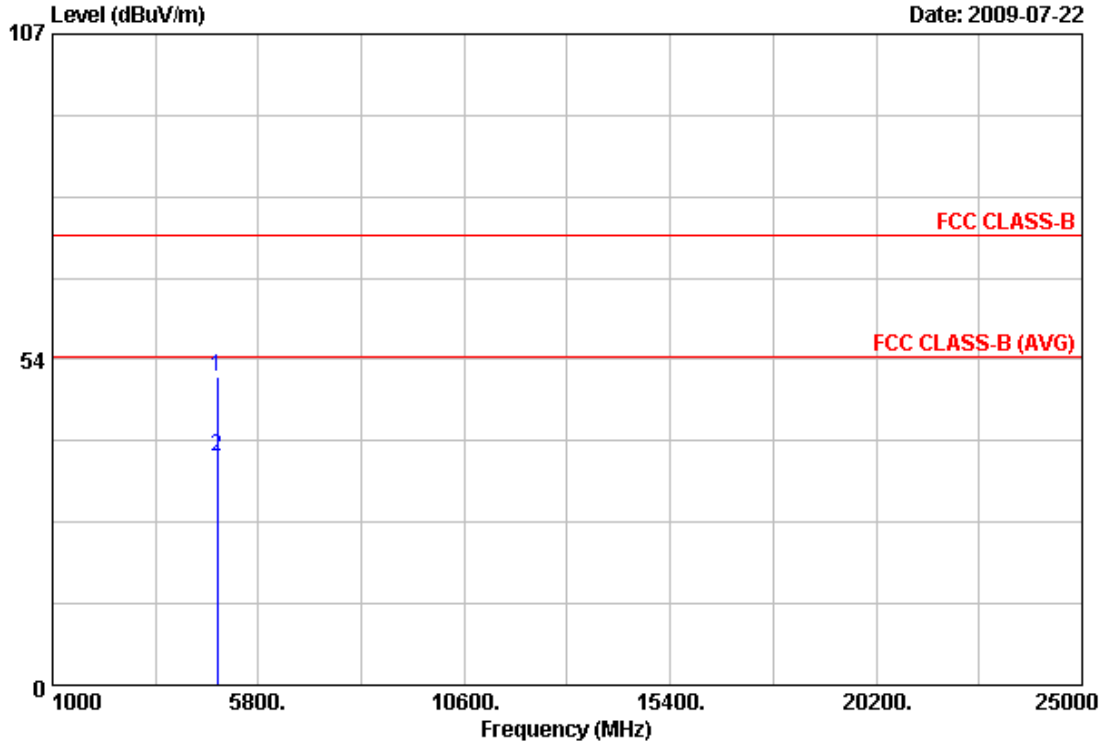

Item	Freq	Read Value	Factor	Result	Limit	Margin	Remark	Ant Pos	Tab Pos
	MHz	dBuV/m	dB	dBuV/m	dBuV/m	dB		cm	Deg
1	4842.45	45.40	5.40	50.80	74.00	-23.20	Peak	100	0
2	4844.85	32.24	5.40	37.64	54.00	-16.36	Average	100	0

Notes:

1. Result = Read Value + Factor
2. Factor = Antenna Factor + Cable Loss - Amplifier
3. The resolution bandwidth of test receiver/spectrum analyzer is 120KHz and video bandwidth is 300kHz for Peak detection and Quasi-peak detection at frequency below 1GHz.
4. The resolution bandwidth of test receiver/spectrum analyzer is 1MHz and video bandwidth is 3MHz for Peak detection at frequency above 1GHz.
5. The resolution bandwidth of test receiver/spectrum analyzer is 1MHz and video bandwidth is 10Hz for Average detection at frequency above 1GHz.
6. The other emissions is too low to be measured.





Power	: AC 120V	Pol/Phase	: VERTICAL
Test Mode 2	: Transmit / Receive	Temperature	: 26 °C
Operation Channel	: 6	Humidity	: 58 %
Modulation Type	: 802.11n, HT40	Atmospheric Pressure	: 1023 hPa
Memo	: Adapter: AD661F0916BLF	Rate	: 13.5Mbps

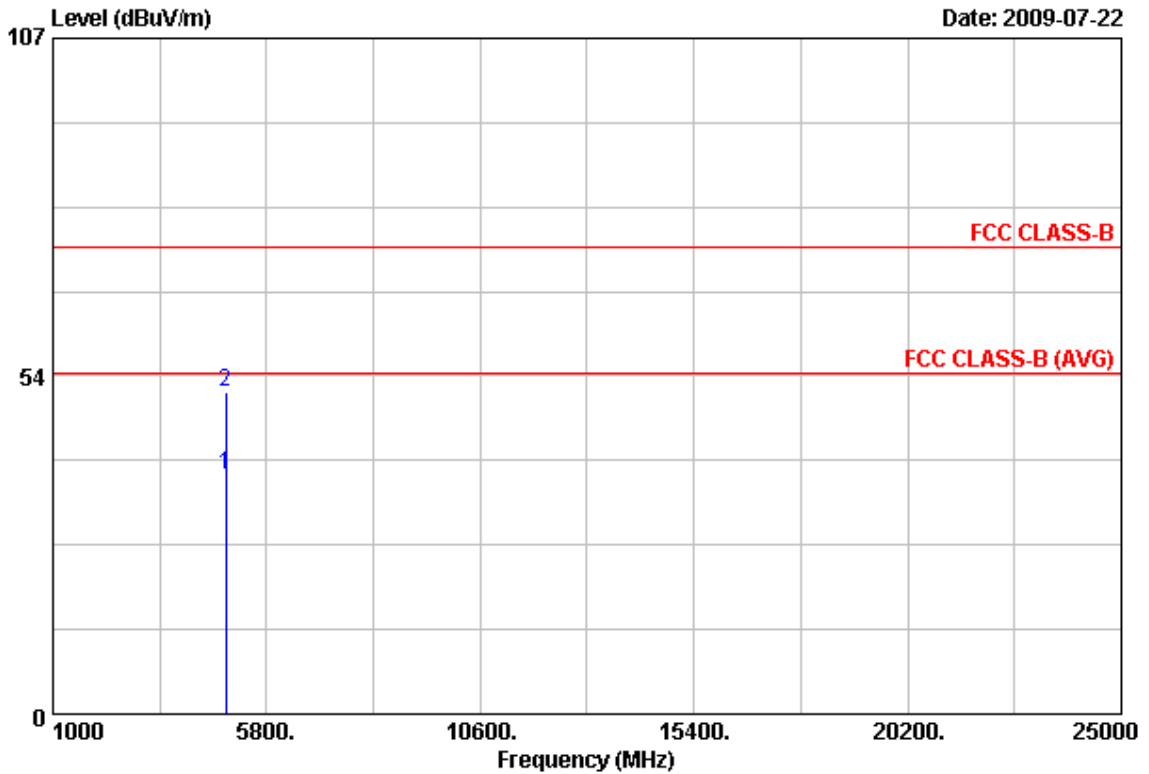

Item	Freq	Read Value	Factor	Result	Limit	Margin	Remark	Ant Pos	Tab Pos
	MHz	dBuV/m	dB	dBuV/m	dBuV/m	dB		cm	Deg
1	4873.50	32.40	5.49	37.89	54.00	-16.11	Average	100	0
2	4873.50	45.61	5.49	51.10	74.00	-22.90	Peak	100	0

Notes:

1. Result = Read Value + Factor
2. Factor = Antenna Factor + Cable Loss - Amplifier
3. The resolution bandwidth of test receiver/spectrum analyzer is 120KHz and video bandwidth is 300kHz for Peak detection and Quasi-peak detection at frequency below 1GHz.
4. The resolution bandwidth of test receiver/spectrum analyzer is 1MHz and video bandwidth is 3MHz for Peak detection at frequency above 1GHz.
5. The resolution bandwidth of test receiver/spectrum analyzer is 1MHz and video bandwidth is 10Hz for Average detection at frequency above 1GHz.
6. The other emissions is too low to be measured.



Power	: AC 120V	Pol/Phase	: HORIZONTAL
Test Mode 2	: Transmit / Receive	Temperature	: 26 °C
Operation Channel	: 6	Humidity	: 58 %
Modulation Type	: 802.11n, HT40	Atmospheric Pressure	: 1023 hPa
Memo	: Adapter: AD661F0916BLF	Rate	: 13.5Mbps

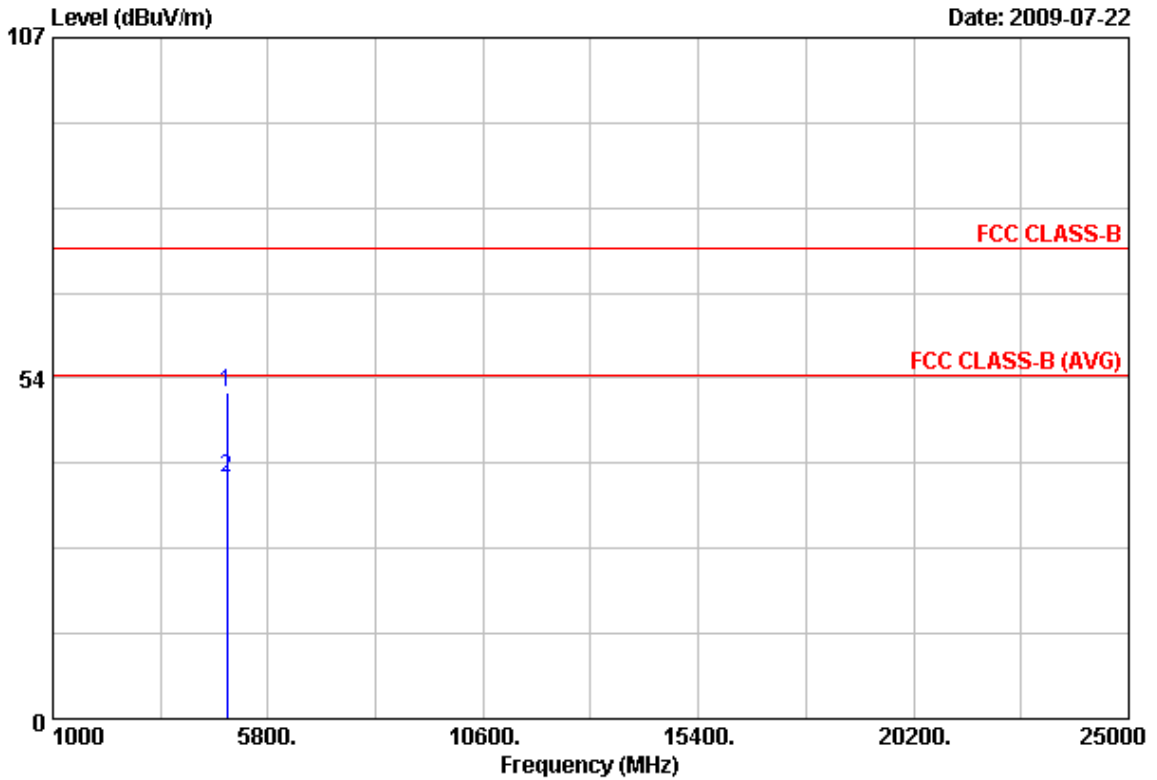

Item	Freq	Read Value	Factor	Result	Limit	Margin	Remark	Ant Pos	Tab Pos
	MHz	dBuV/m	dB	dBuV/m	dBuV/m	dB		cm	Deg
1	4873.50	45.81	5.49	51.30	74.00	-22.70	Peak	100	0
2	4875.40	32.39	5.51	37.90	54.00	-16.10	Average	100	0

Notes:

1. Result = Read Value + Factor
2. Factor = Antenna Factor + Cable Loss - Amplifier
3. The resolution bandwidth of test receiver/spectrum analyzer is 120KHz and video bandwidth is 300KHz for Peak detection and Quasi-peak detection at frequency below 1GHz.
4. The resolution bandwidth of test receiver/spectrum analyzer is 1MHz and video bandwidth is 3MHz for Peak detection at frequency above 1GHz.
5. The resolution bandwidth of test receiver/spectrum analyzer is 1MHz and video bandwidth is 10Hz for Average detection at frequency above 1GHz.
6. The other emissions is too low to be measured.



Power	: AC 120V	Pol/Phase	: VERTICAL
Test Mode 2	: Transmit / Receive	Temperature	: 26 °C
Operation Channel	: 9	Humidity	: 58 %
Modulation Type	: 802.11n, HT40	Atmospheric Pressure	: 1023 hPa
Memo	: Adapter: AD661F0916BLF	Rate	: 13.5Mbps

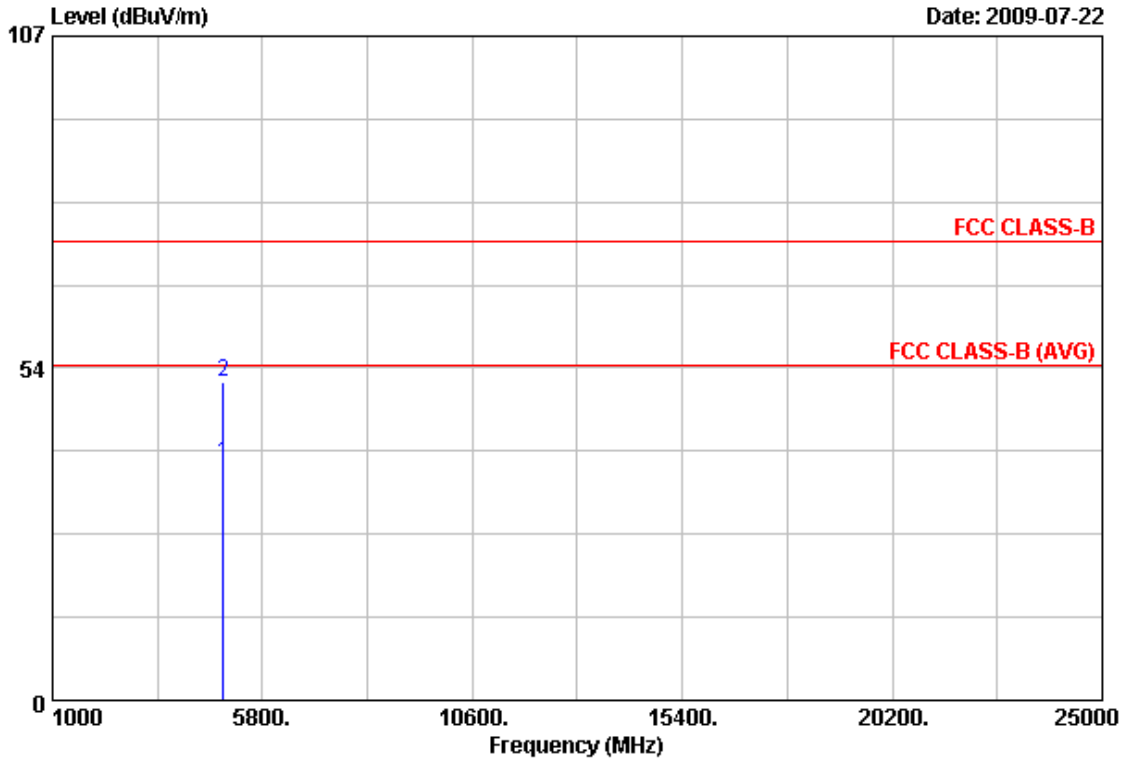

Item	Freq	Read Value	Factor	Result	Limit	Margin	Remark	Ant Pos	Tab Pos
	MHz	dBuV/m	dB	dBuV/m	dBuV/m	dB		cm	Deg
1	4903.30	32.43	5.59	38.02	54.00	-15.98	Average	100	0
2	4904.90	45.70	5.60	51.30	74.00	-22.70	Peak	100	0

Notes:

1. Result = Read Value + Factor
2. Factor = Antenna Factor + Cable Loss - Amplifier
3. The resolution bandwidth of test receiver/spectrum analyzer is 120KHz and video bandwidth is 300kHz for Peak detection and Quasi-peak detection at frequency below 1GHz.
4. The resolution bandwidth of test receiver/spectrum analyzer is 1MHz and video bandwidth is 3MHz for Peak detection at frequency above 1GHz.
5. The resolution bandwidth of test receiver/spectrum analyzer is 1MHz and video bandwidth is 10Hz for Average detection at frequency above 1GHz.
6. The other emissions is too low to be measured.



Power	: AC 120V	Pol/Phase	: HORIZONTAL
Test Mode 2	: Transmit / Receive	Temperature	: 26 °C
Operation Channel	: 9	Humidity	: 58 %
Modulation Type	: 802.11n, HT40	Atmospheric Pressure	: 1023 hPa
Memo	: Adapter: AD661F0916BLF	Rate	: 13.5Mbps

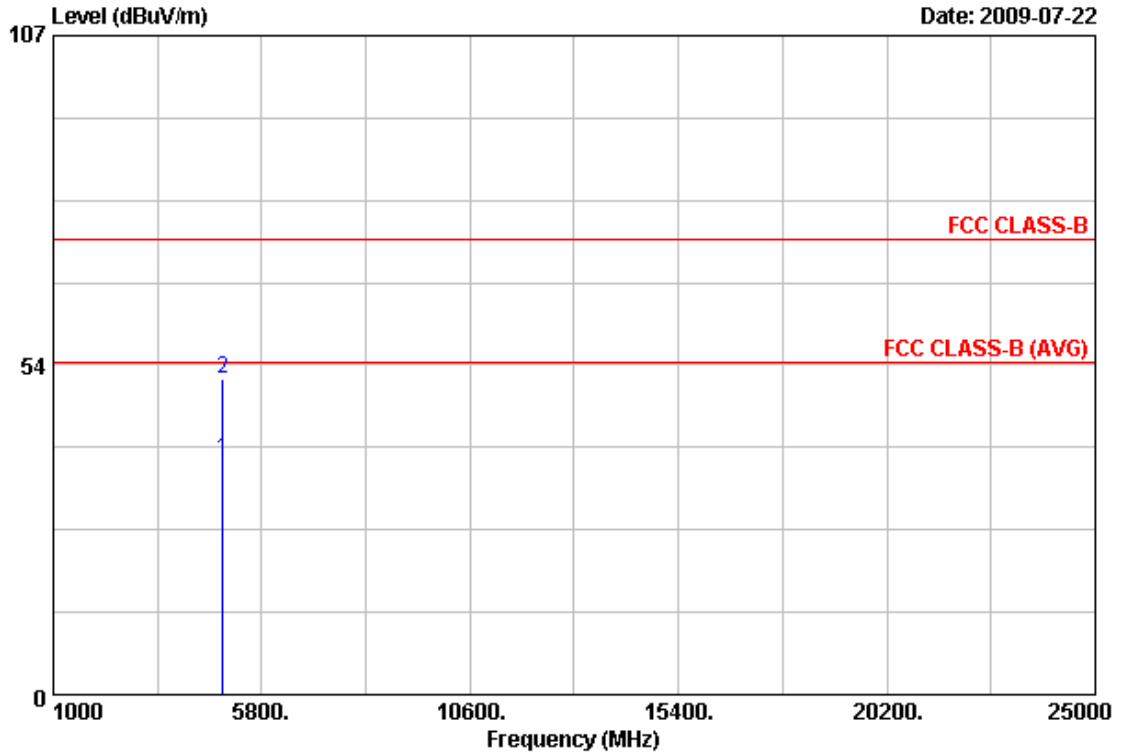

Item	Freq	Read Value	Factor	Result	Limit	Margin	Remark	Ant Pos	Tab Pos
	MHz	dBuV/m	dB	dBuV/m	dBuV/m	dB		cm	Deg
1	4902.35	32.47	5.58	38.05	54.00	-15.95	Average	100	0
2	4903.35	45.53	5.59	51.12	74.00	-22.88	Peak	100	0

Notes:

1. Result = Read Value + Factor
2. Factor = Antenna Factor + Cable Loss - Amplifier
3. The resolution bandwidth of test receiver/spectrum analyzer is 120KHz and video bandwidth is 300KHz for Peak detection and Quasi-peak detection at frequency below 1GHz.
4. The resolution bandwidth of test receiver/spectrum analyzer is 1MHz and video bandwidth is 3MHz for Peak detection at frequency above 1GHz.
5. The resolution bandwidth of test receiver/spectrum analyzer is 1MHz and video bandwidth is 10Hz for Average detection at frequency above 1GHz.
6. The other emissions is too low to be measured.

Test engineer: Ben



## 6. 6dB Bandwidth Measurement Data

### 6.1 Test Limit

The minimum of 6dB Bandwidth Measurement is 0.5 MHz.

### 6.2 Test Procedures

- The transmitter output was connected to the spectrum analyzer.
- Set RBW of spectrum analyzer to 100 KHz and VBW to 100 KHz.
- The 6 dB bandwidth is defined as the total spectrum the power of which is higher than peak power minus 6 dB.

### 6.3 Test Setup Layout

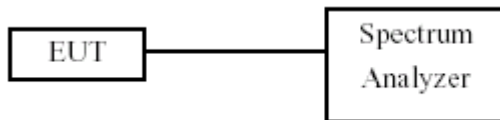

### 6.4 Measurement equipment

Instrument/Ancillary	Model No.	Manufacturer	Serial No.	Calibration Date	Valid Date
Spectrum Analyzer	FSP40	R&S	10047	2009/03/26	2010/03/25

### 6.5 Test Result and Data

Test Date: Jun. 20, 2009

Temperature: 26

Atmospheric pressure: 1012 hPa

Humidity: 64%

Modulation Standard	Channel	Frequency (MHz)	6dB Bandwidth (MHz)	
			Ant1	Ant2
802.11b (11Mbps)	01	2412	12.1	12
	06	2437	12.1	12.1
	11	2462	12.4	12
802.11g (6Mbps)	01	2412	16.5	16.5
	06	2437	16.6	16.6
	11	2462	16.6	16.6
802.11n, HT20 (6.5Mbps)	01	2412	17.8	17.8
	06	2437	17.8	17.8
	11	2462	17.6	17.5
802.11n, HT40 (13.5Mbps)	03	2422	36.2	36.4
	06	2437	36.6	36.2
	09	2452	36.4	36.4



Modulation Standard: 802.11b (11Mbps), Ant1  
Channel: 01

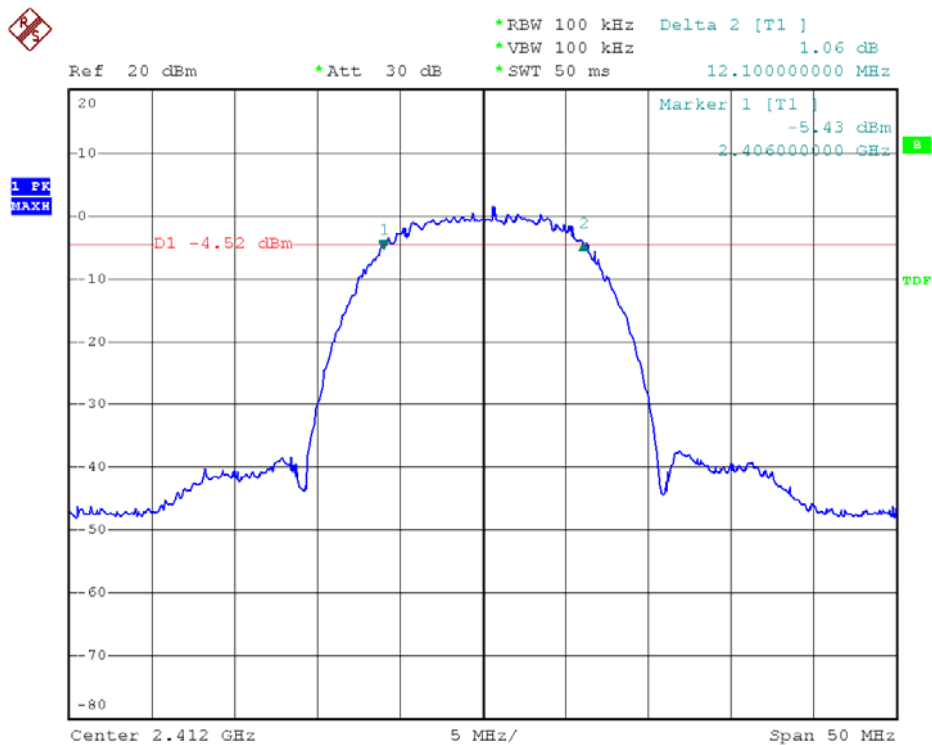

Modulation Standard: 802.11b (11Mbps), Ant2  
Channel: 01

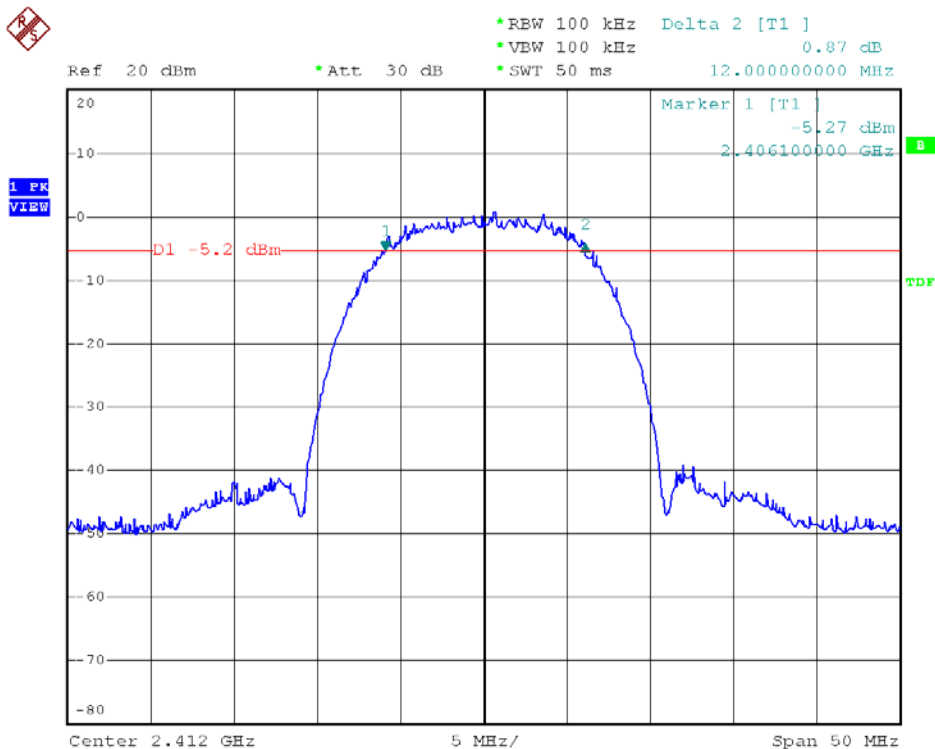



Modulation Standard: 802.11b (11Mbps), Ant1  
Channel: 06

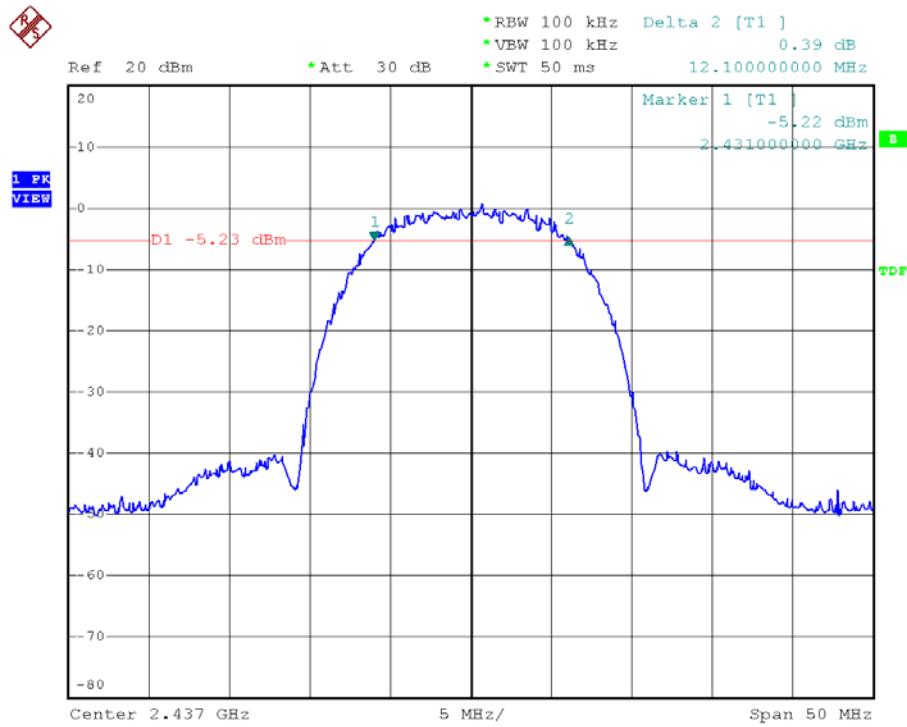

Modulation Standard: 802.11b (11Mbps), Ant2  
Channel: 06

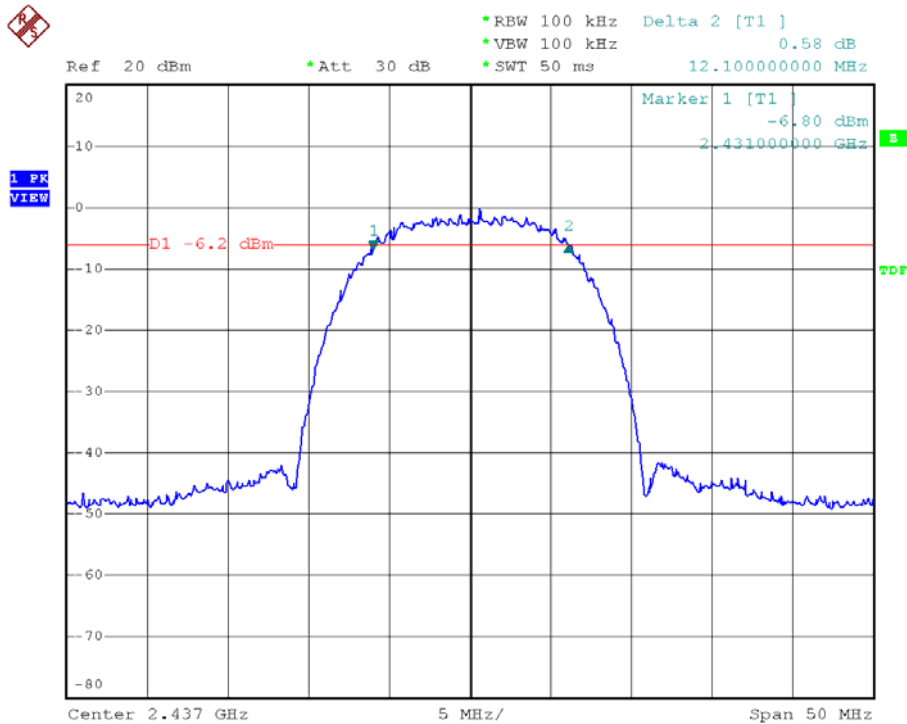



Modulation Standard: 802.11b (11Mbps), Ant1  
Channel: 11

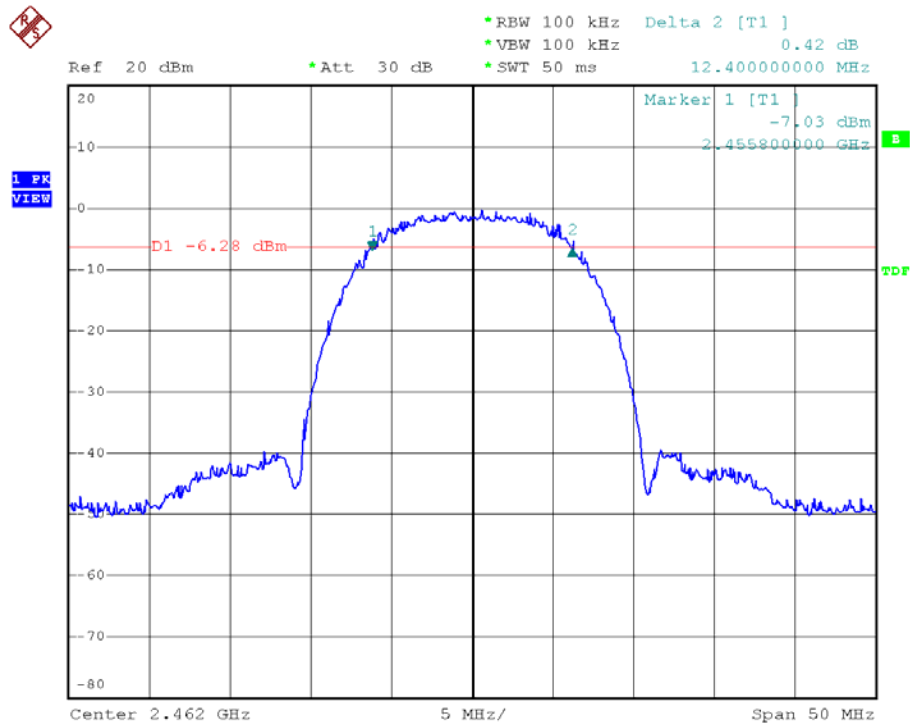

Modulation Standard: 802.11b (11Mbps), Ant2  
Channel: 11

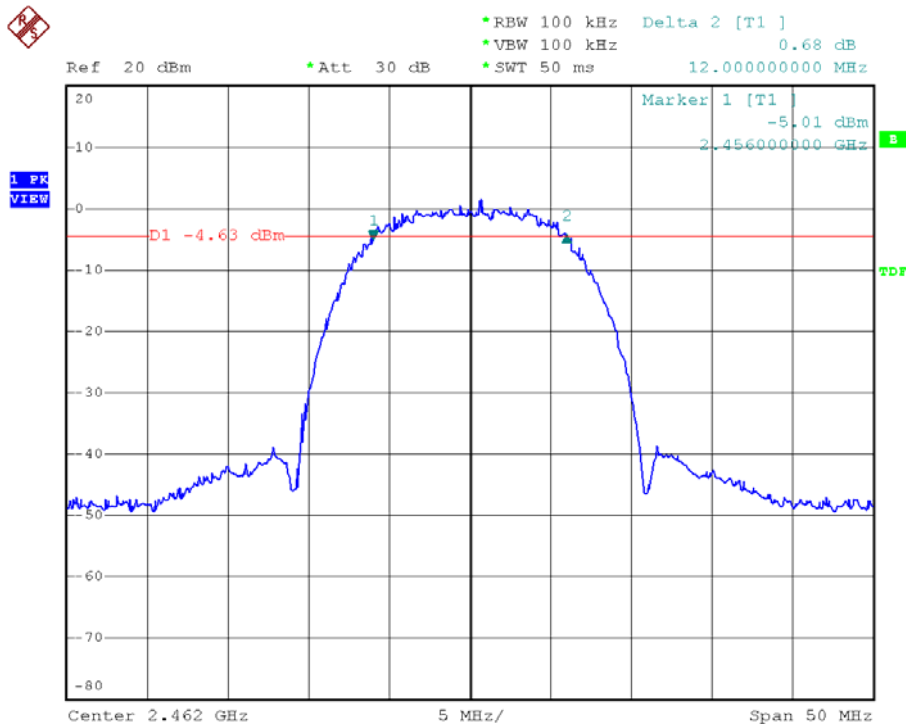





Modulation Standard: 802.11g (6Mbps), Ant1  
Channel: 01

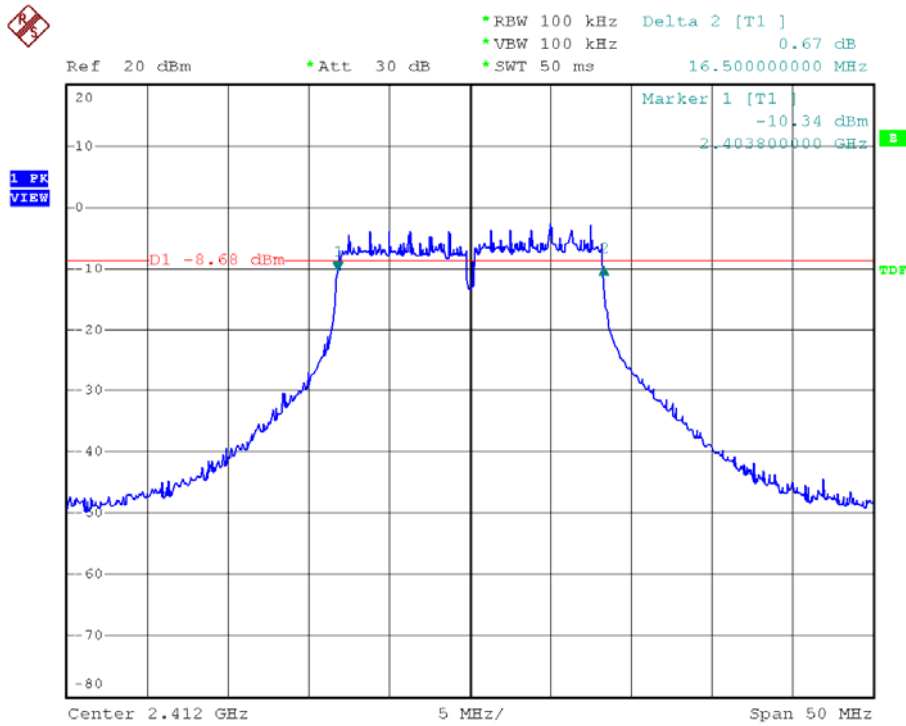

Modulation Standard: 802.11g (6Mbps), Ant2  
Channel: 01

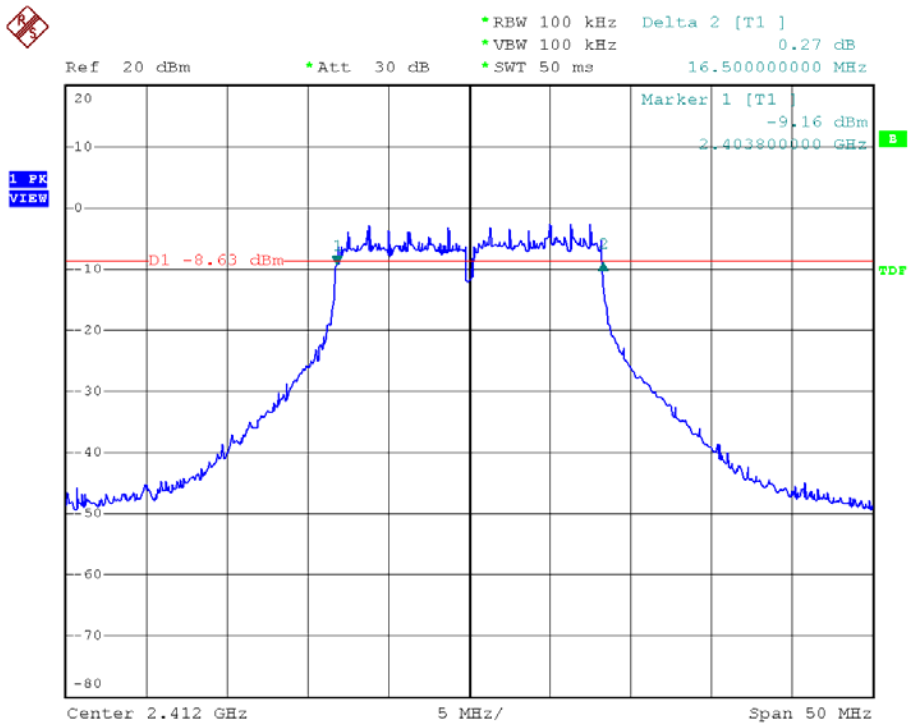



Modulation Standard: 802.11g (6Mbps), Ant1  
Channel: 06

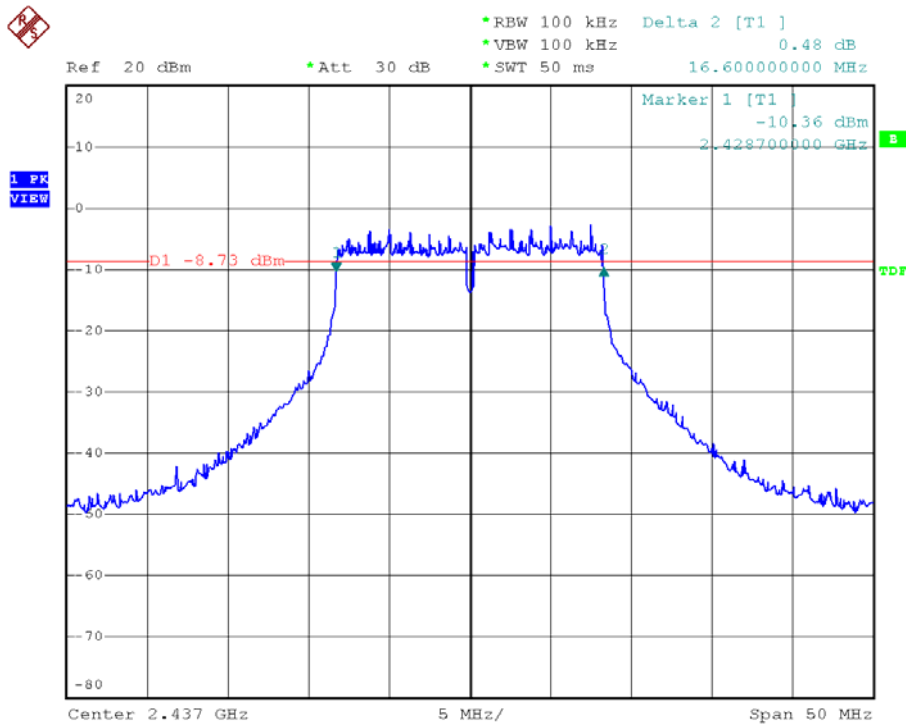

Modulation Standard: 802.11g (6Mbps), Ant2  
Channel: 06

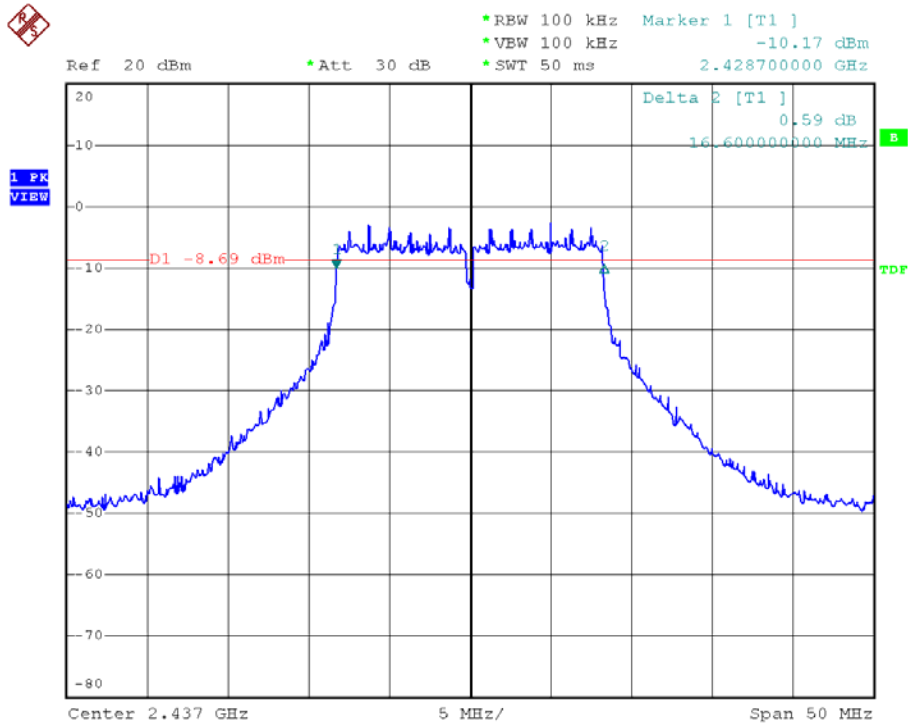



Modulation Standard: 802.11g (6Mbps), Ant1  
Channel: 11

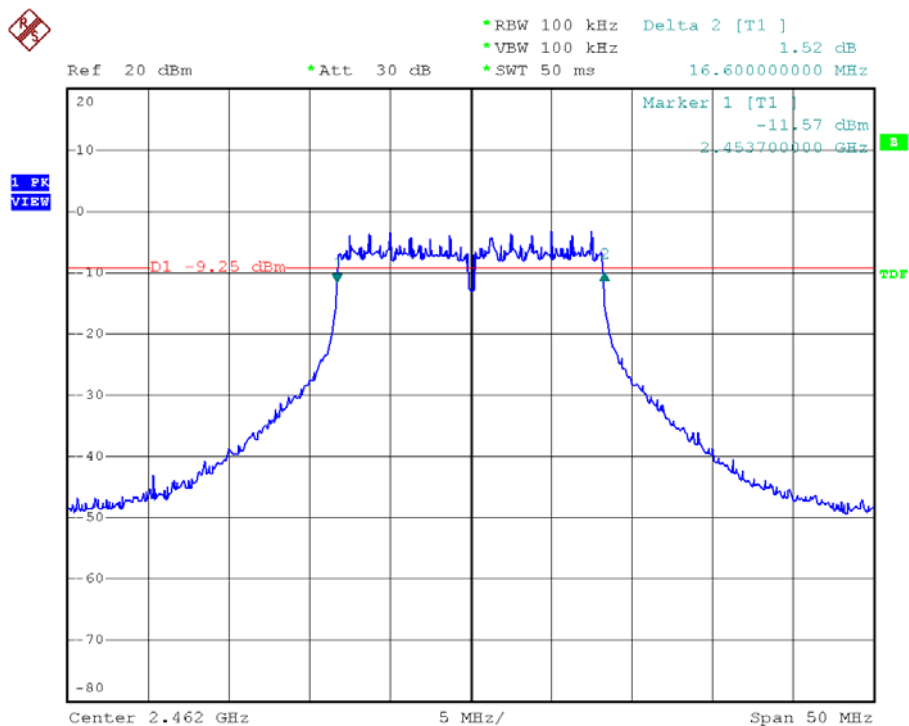

Modulation Standard: 802.11g (6Mbps), Ant2  
Channel: 11

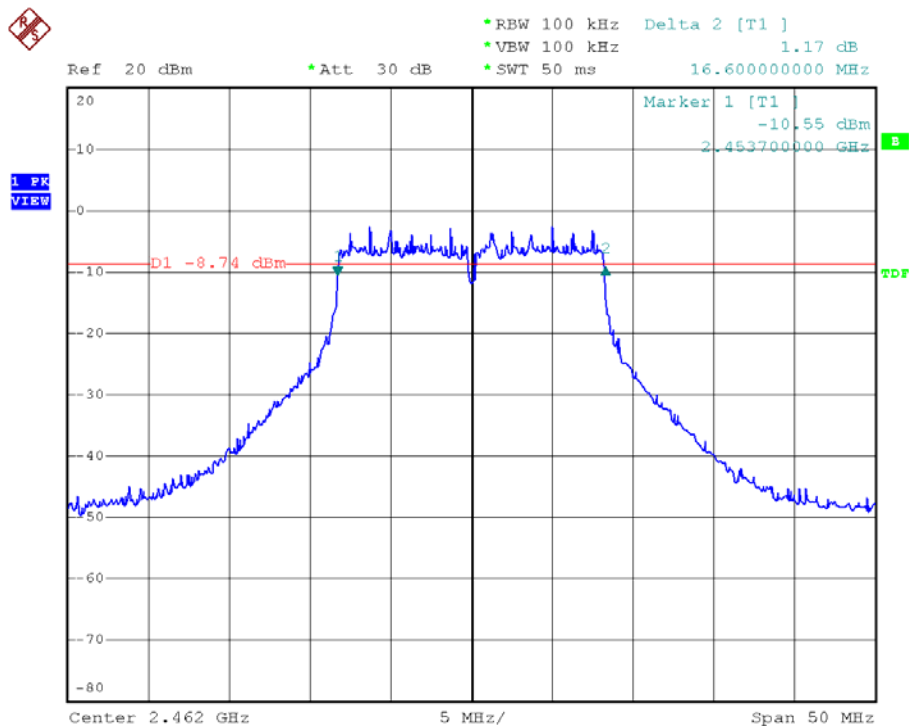



Modulation Standard: 802.11n, HT20 (6.5Mbps), Ant1  
Channel: 01

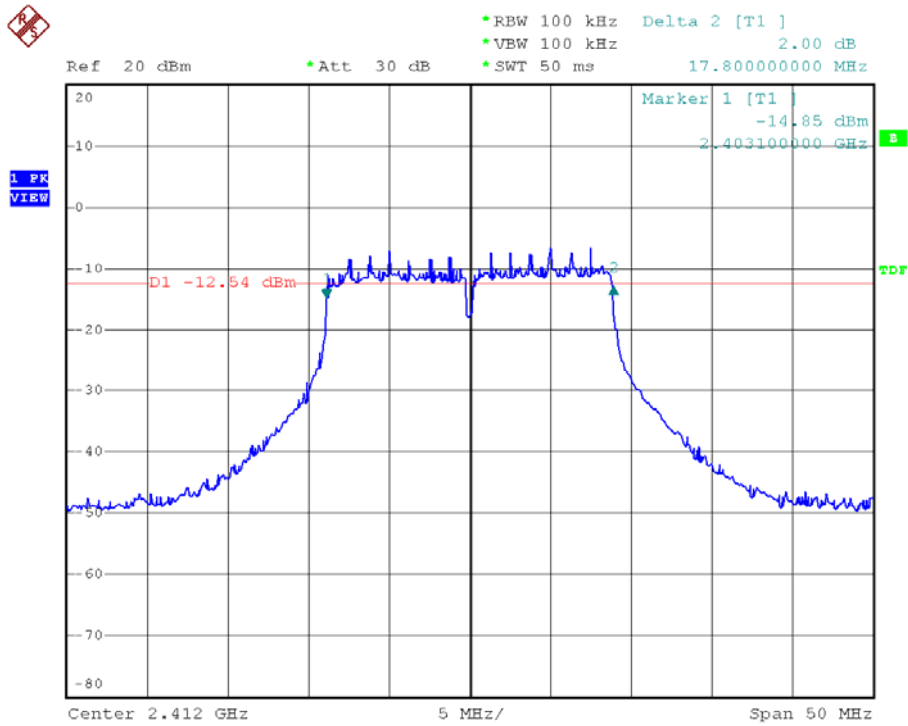

Modulation Standard: 802.11n, HT20 (6.5Mbps), Ant2  
Channel: 01

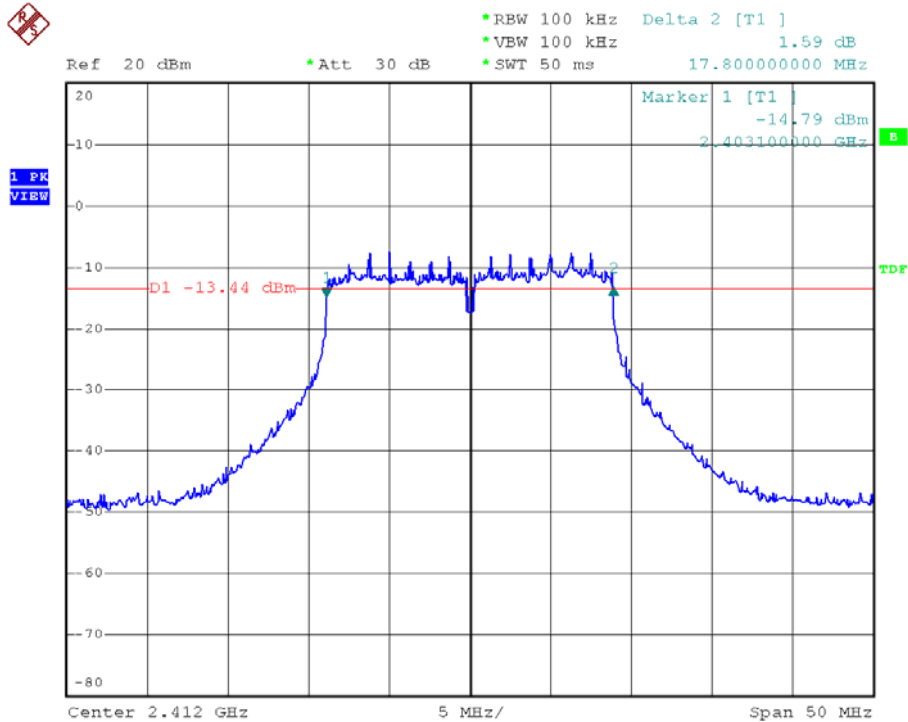



Modulation Standard: 802.11n, HT20 (6.5Mbps), Ant1  
Channel: 06

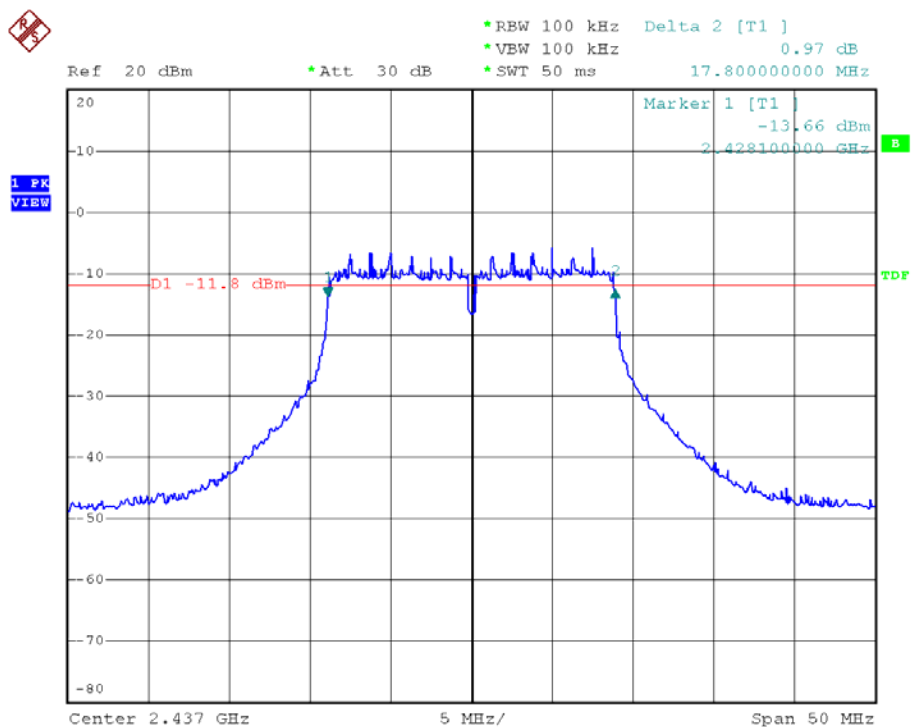

Modulation Standard: 802.11n, HT20 (6.5Mbps), Ant2  
Channel: 06

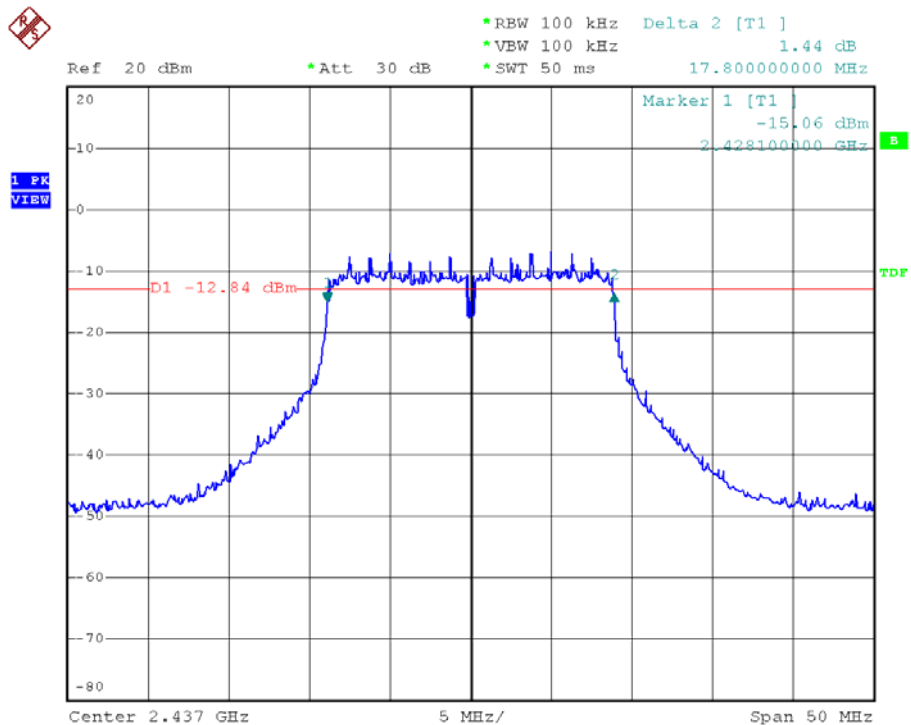



Modulation Standard: 802.11n, HT20 (6.5Mbps), Ant1  
Channel: 11

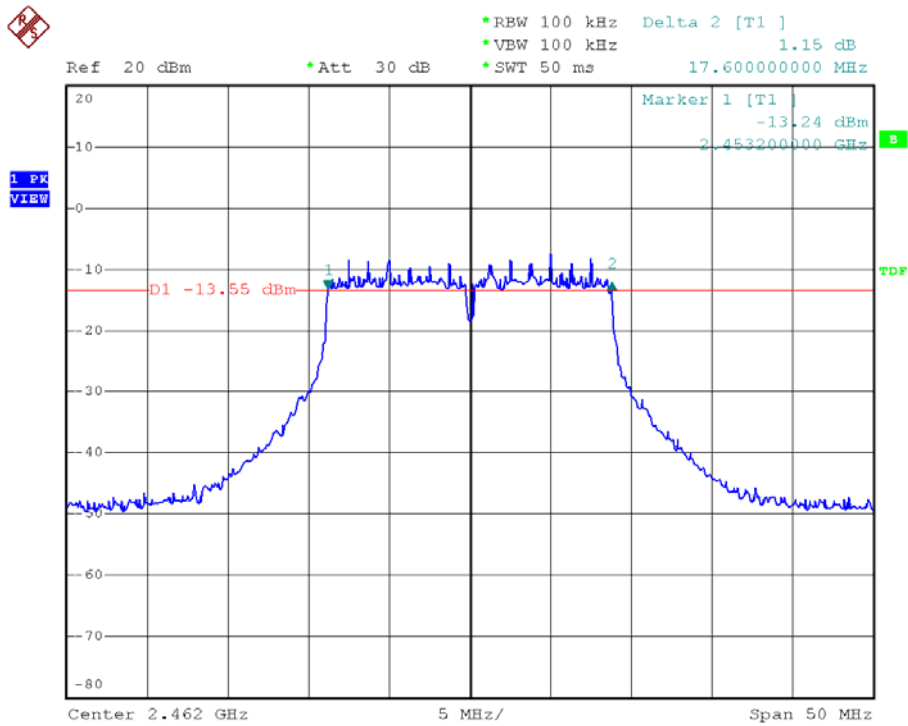

Modulation Standard: 802.11n, HT20 (6.5Mbps), Ant2  
Channel: 11

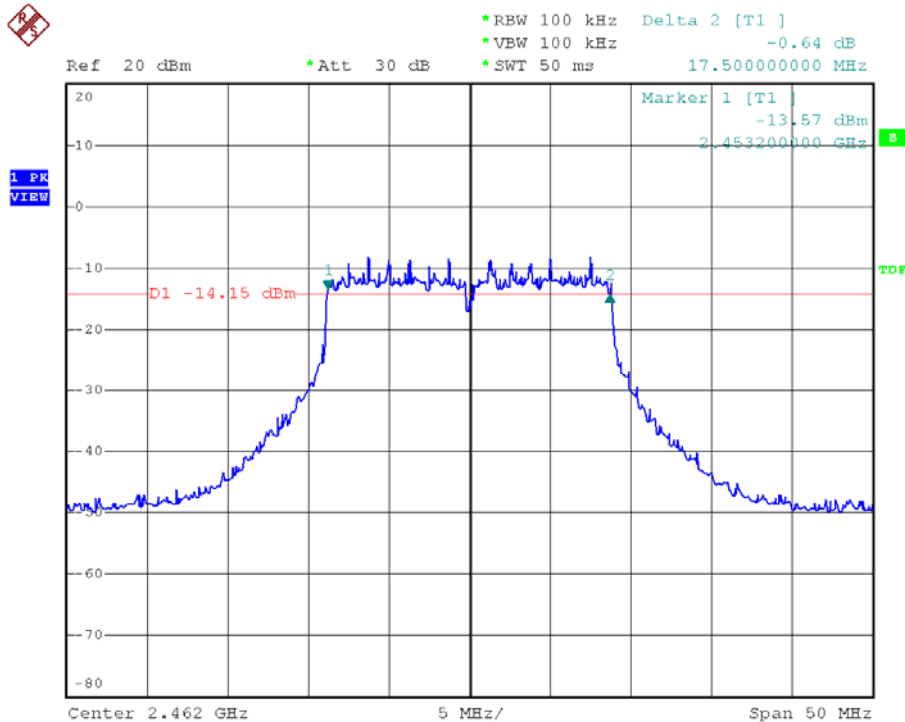



Modulation Standard: 802.11n, HT40 (13.5Mbps), Ant1  
Channel: 03

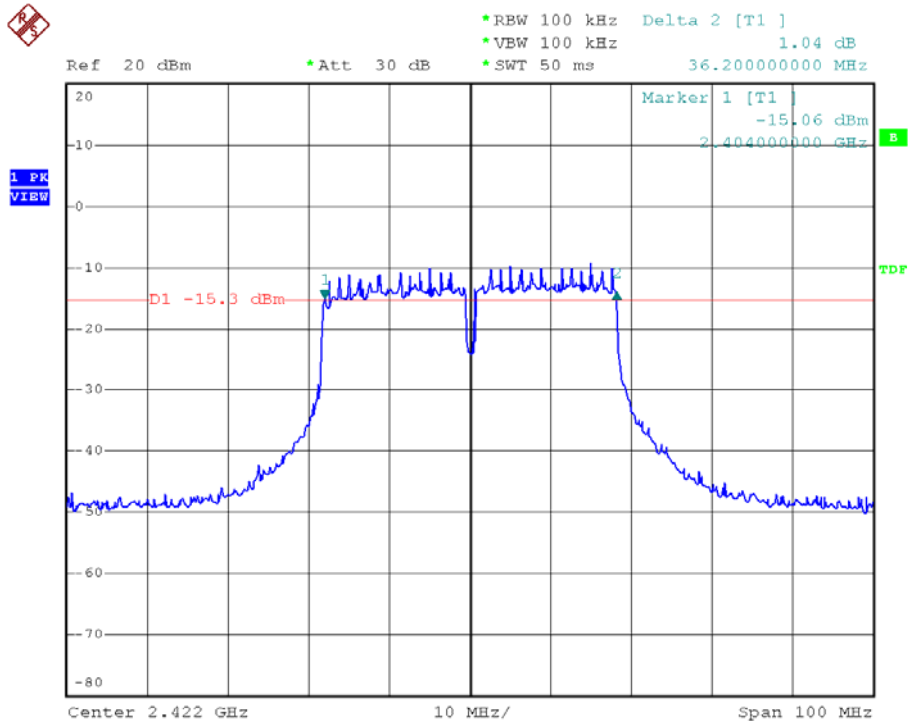

Modulation Standard: 802.11n, HT40 (13.5Mbps), Ant2  
Channel: 03

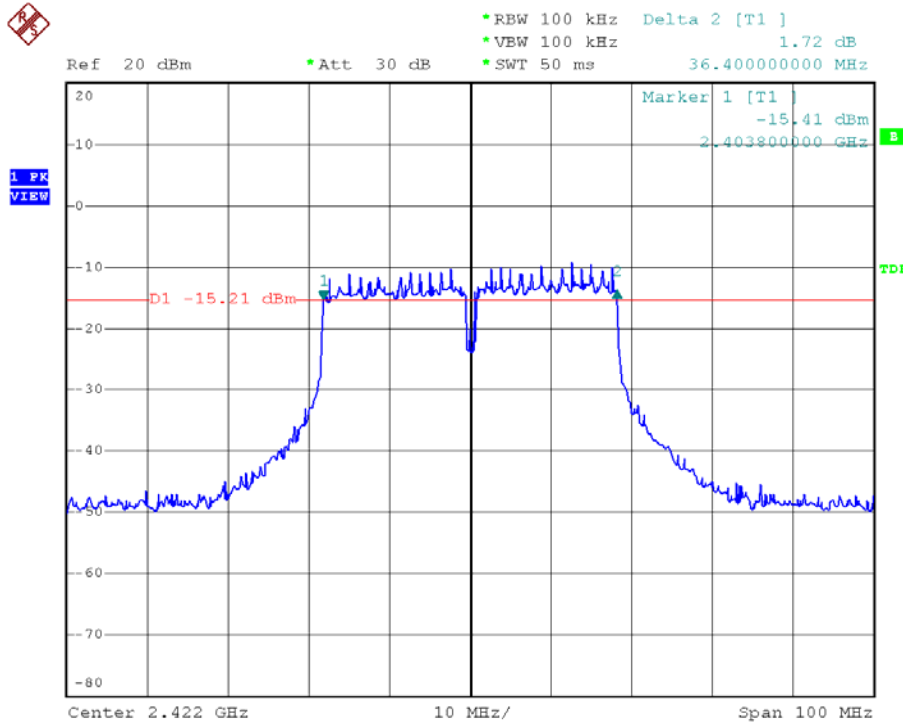



Modulation Standard: 802.11n, HT40 (13.5Mbps), Ant1  
Channel: 06

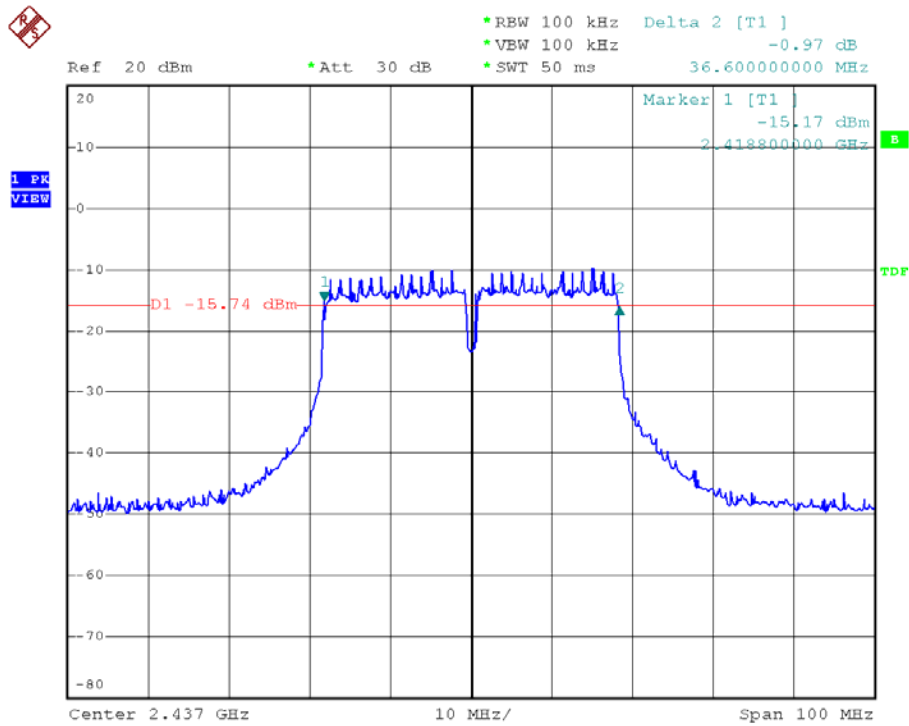

Modulation Standard: 802.11n, HT40 (13.5Mbps), Ant2  
Channel: 06

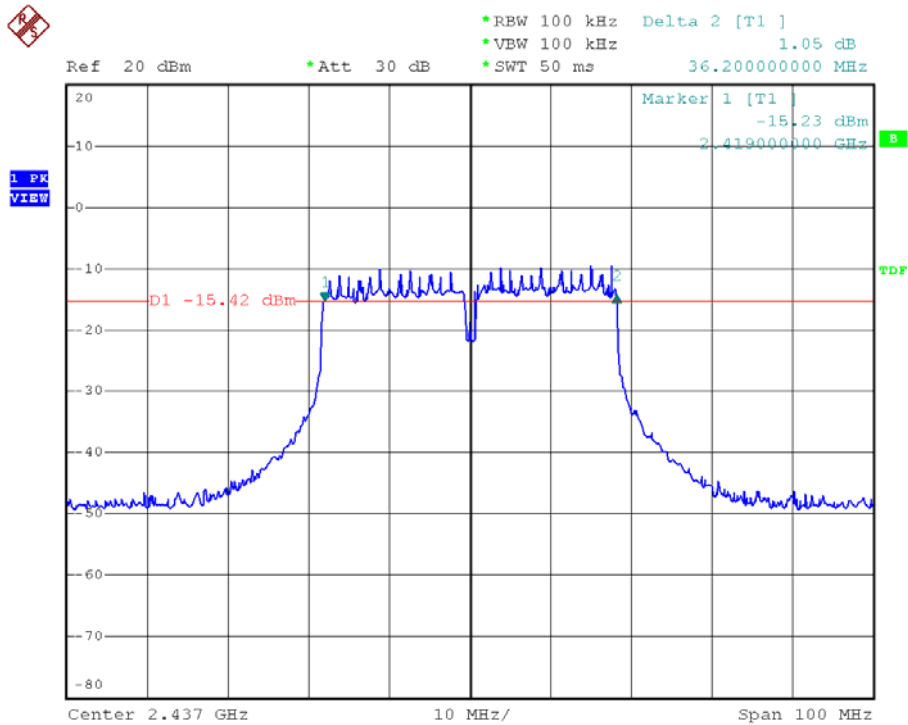





Modulation Standard: 802.11n, HT40 (13.5Mbps), Ant1  
Channel: 09

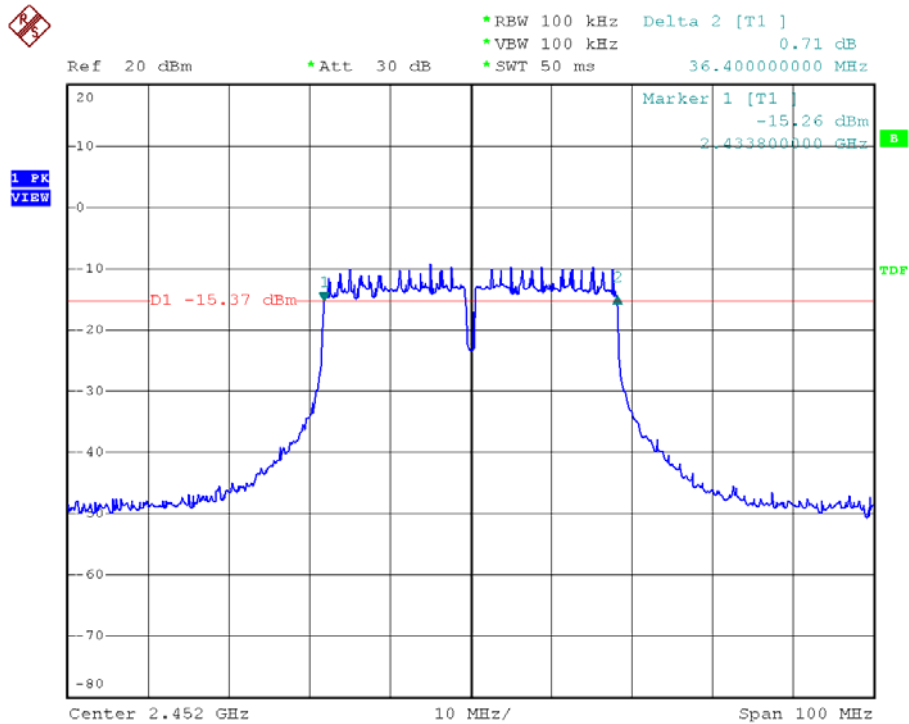

Modulation Standard: 802.11n, HT40 (13.5Mbps), Ant2  
Channel: 09

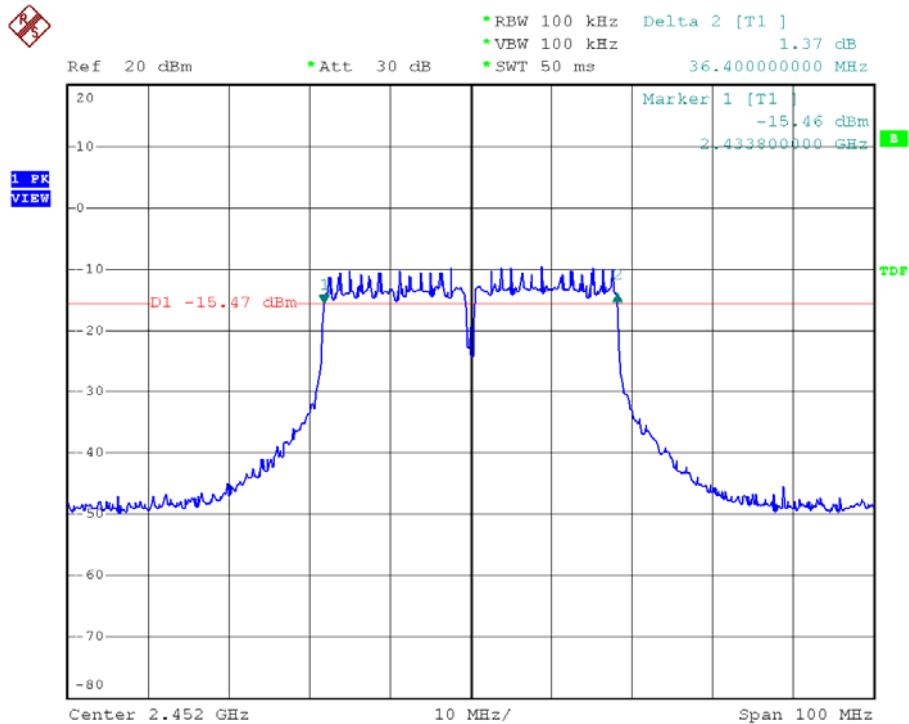



## 7. Maximum Peak Output Power

### 7.1 Test Limit

The Maximum Peak Output Power Measurement is 30dBm.

### 7.2 Test Procedures

The antenna port( RF output )of the EUT was connected to the input( RF input )of a power meter. Power was read directly from the meter and cable loss connection was added to the reading to obtain power at the EUT antenna terminal. The EUT Output Power was set to maximum to produce the worse case test result.

### 7.3 Test Setup Layout

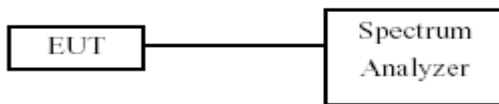

### 7.4 Measurement equipment

Instrument/Ancillary	Model No.	Manufacturer	Serial No.	Calibration Date	Valid Date
Spectrum Analyzer	FSP40	R&S	10047	2009/03/26	2010/03/25

### 7.5 Test Result and Data

Test Date: Jul. 20, 2009

Temperature: 26

Atmospheric pressure: 1012 hPa

Humidity: 64%

Modulation Standard	Channel	Frequency (MHz)	Peak Power Output (dBm)		Peak Power Output (mW)	
			Ant1	Ant2	Ant1	Ant2
802.11b (11Mbps)	01	2412	16.88	17.06	48.8	50.8
	06	2437	17.07	17.32	50.9	54
	11	2462	17.16	17.1	52	51.3
802.11g (6Mbps)	01	2412	17.15	17.1	51.9	51.9
	06	2437	17.05	17.19	50.7	52.4
	11	2462	17.06	17.14	50.8	51.8

Modulation Standard	Channel	Frequency (MHz)	Peak Power Output (dBm)			Peak Power Output (mW)
			Ant1	Ant2	Ant1+Ant2	Ant1+Ant2
802.11n HT20	01	2412	12.98	13.57	16.3	42.61
	06	2437	13.13	13.31	16.23	41.99
	11	2462	13.28	13.12	16.19	41.55
802.11n HT40	03	2422	13.31	13.44	16.39	43.51
	06	2437	13.23	13.04	16.15	41.18
	09	2452	13.35	13.38	16.38	43.4



Modulation Standard: 802.11b (11Mbps), Ant1  
Channel: 01

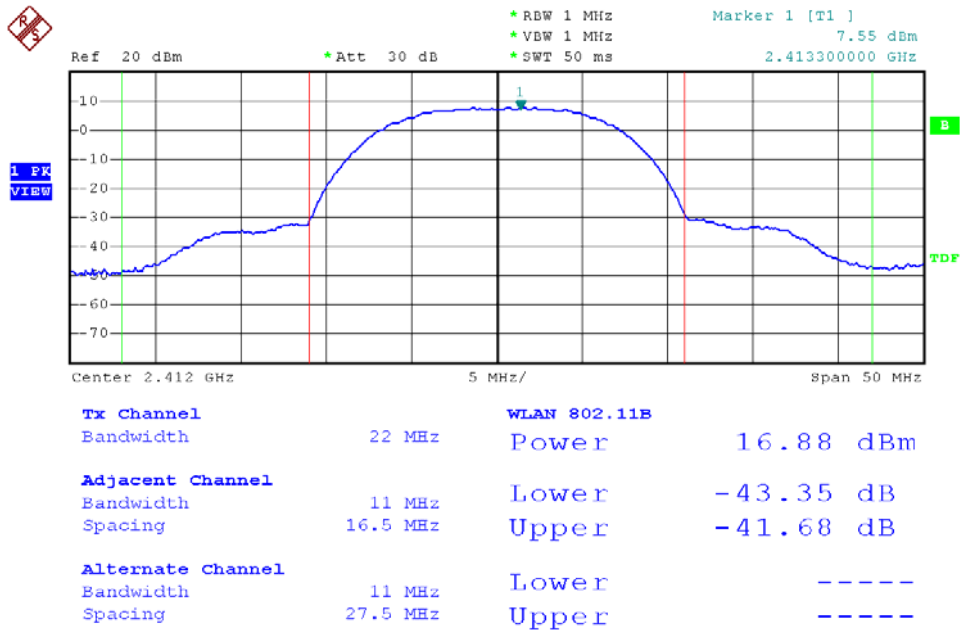

Modulation Standard: 802.11b (11Mbps), Ant2  
Channel: 01

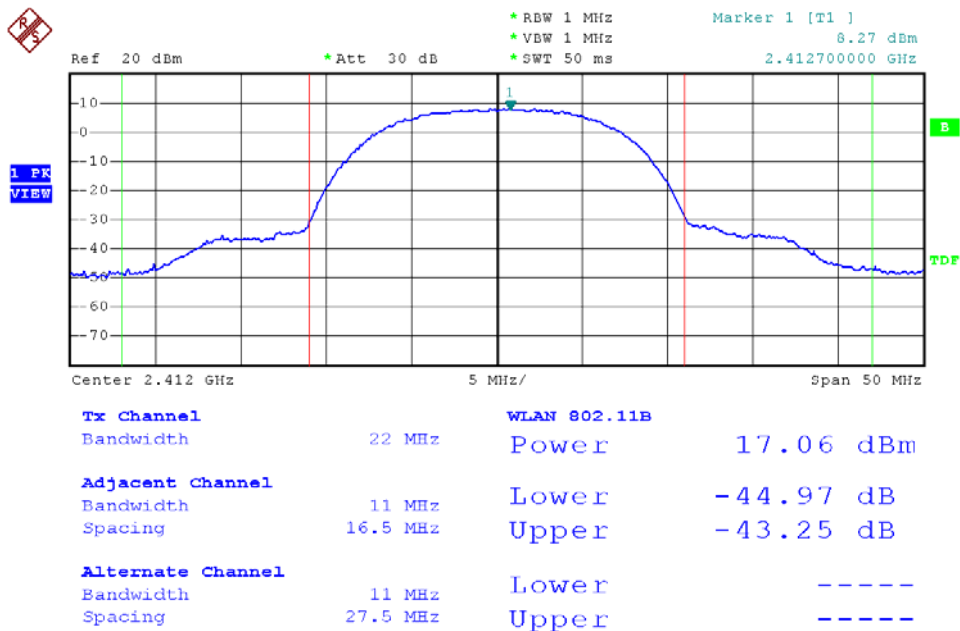



Modulation Standard: 802.11b (11Mbps), Ant1  
Channel: 06

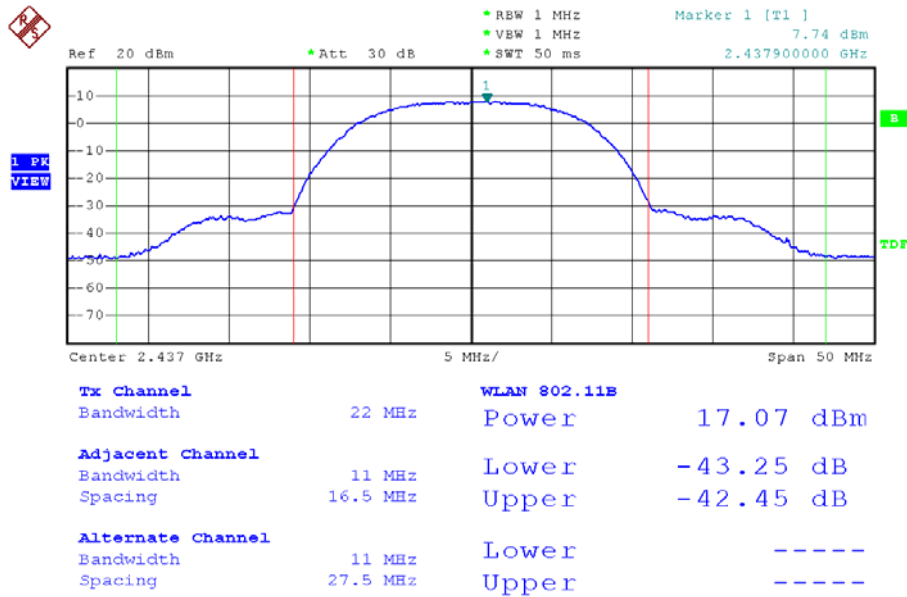

Modulation Standard: 802.11g (54Mbps), Ant2  
Channel: 06

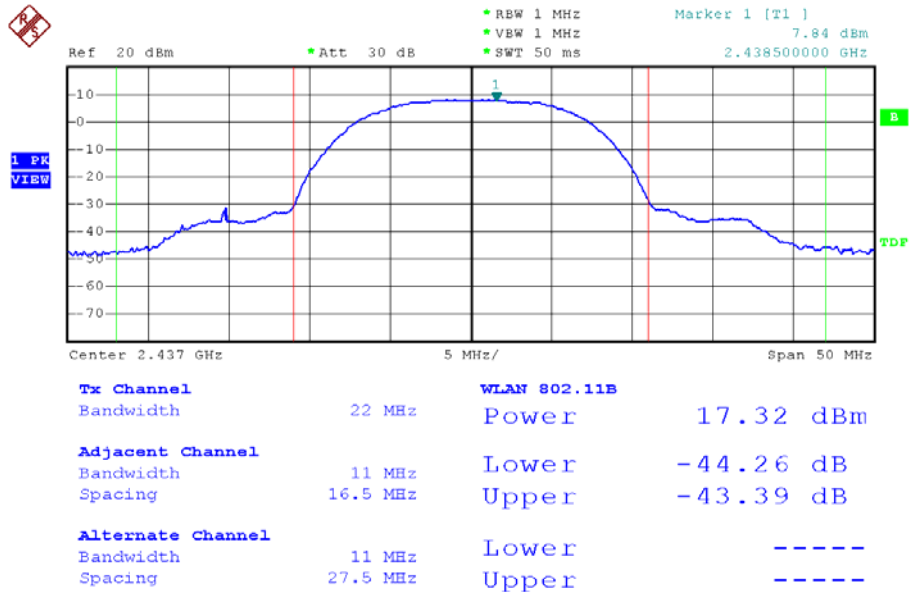



Modulation Standard: 802.11b (11Mbps), Ant1  
Channel: 11

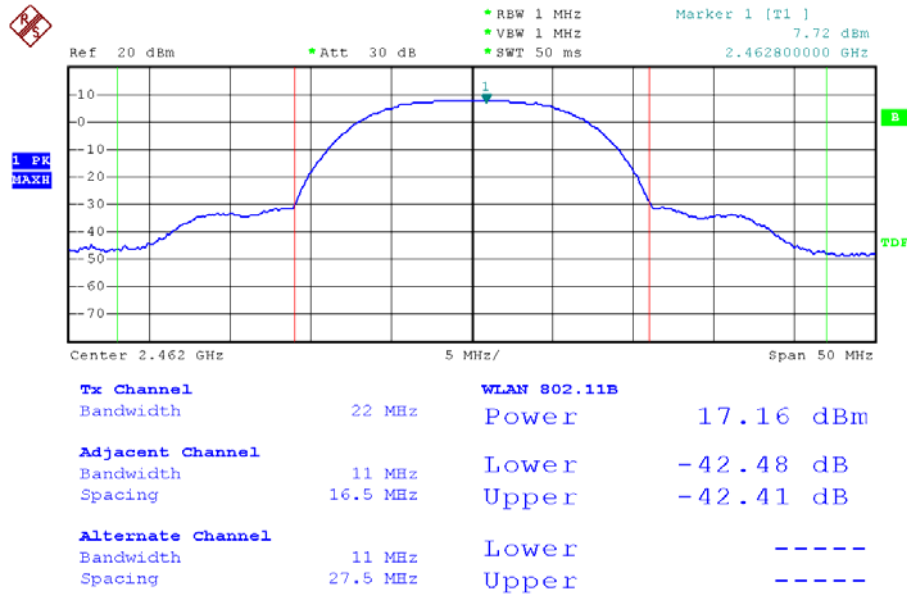

Modulation Standard: 802.11b (11Mbps), Ant2  
Channel: 11

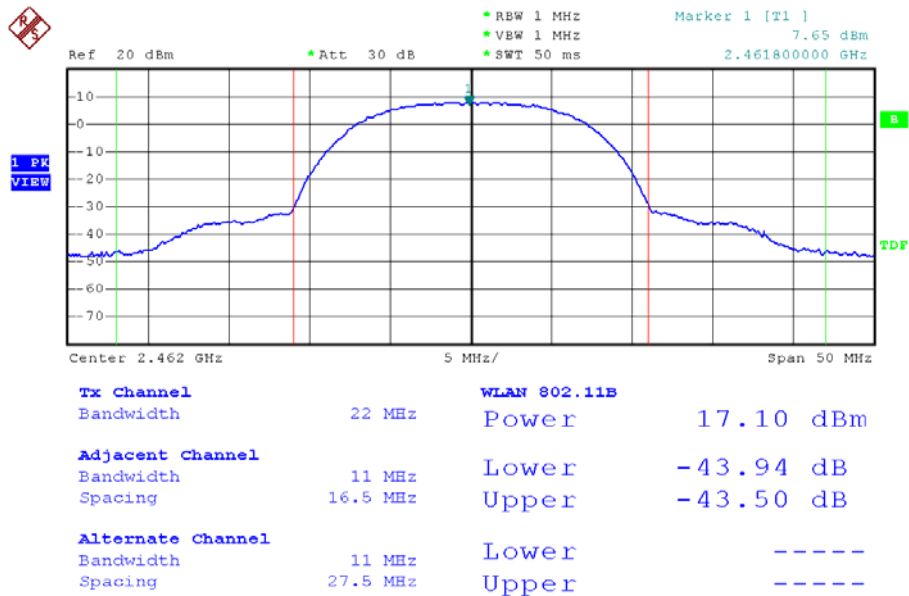



Modulation Standard: 802.11g (6Mbps), Ant1  
Channel: 01

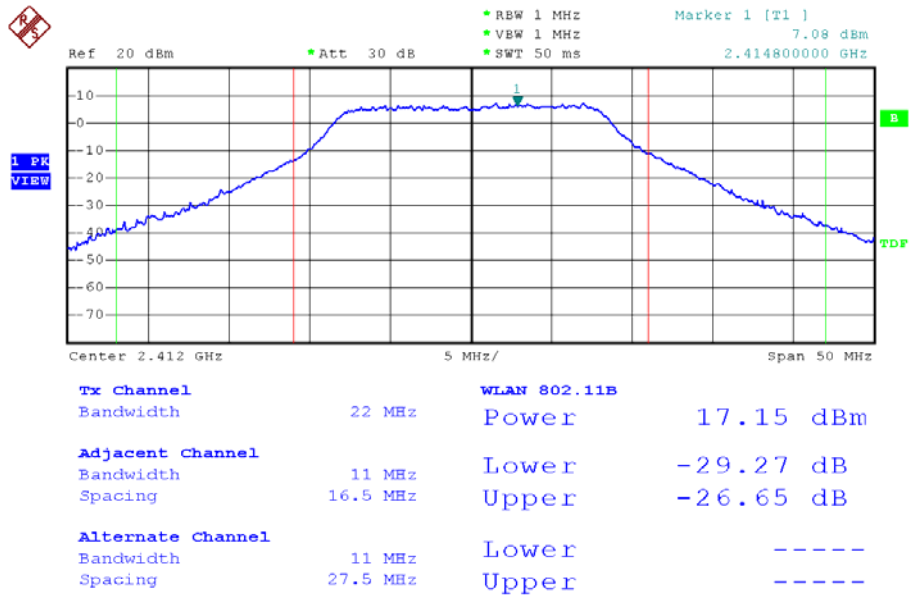

Modulation Standard: 802.11g (6Mbps), Ant2  
Channel: 01

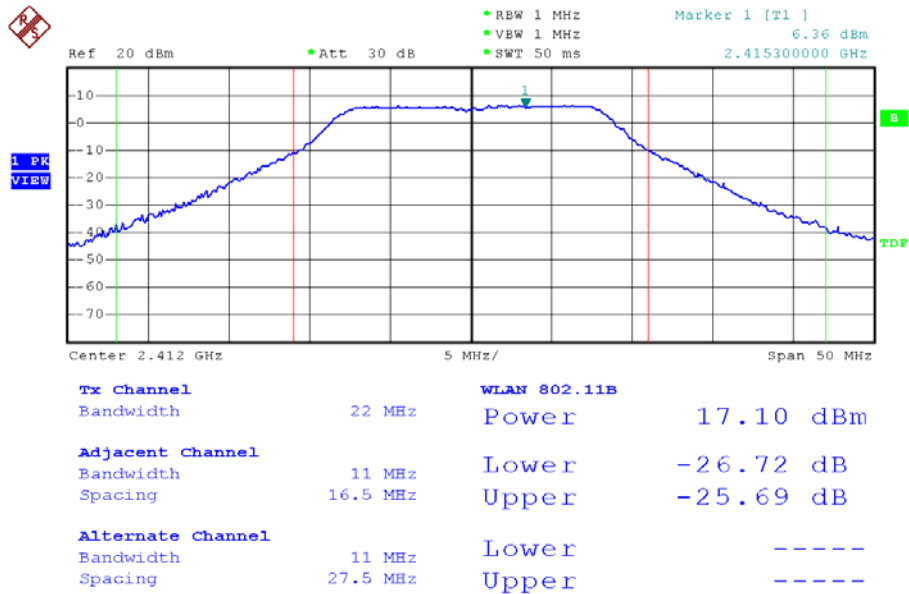





Modulation Standard: 802.11g (6Mbps), Ant1  
Channel: 11

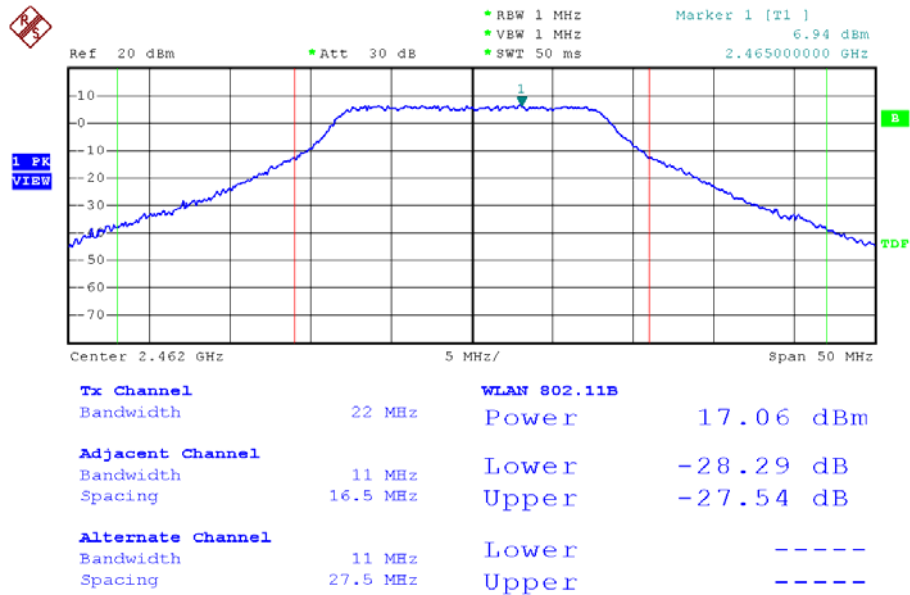

Modulation Standard: 802.11g (6Mbps), Ant2  
Channel: 11

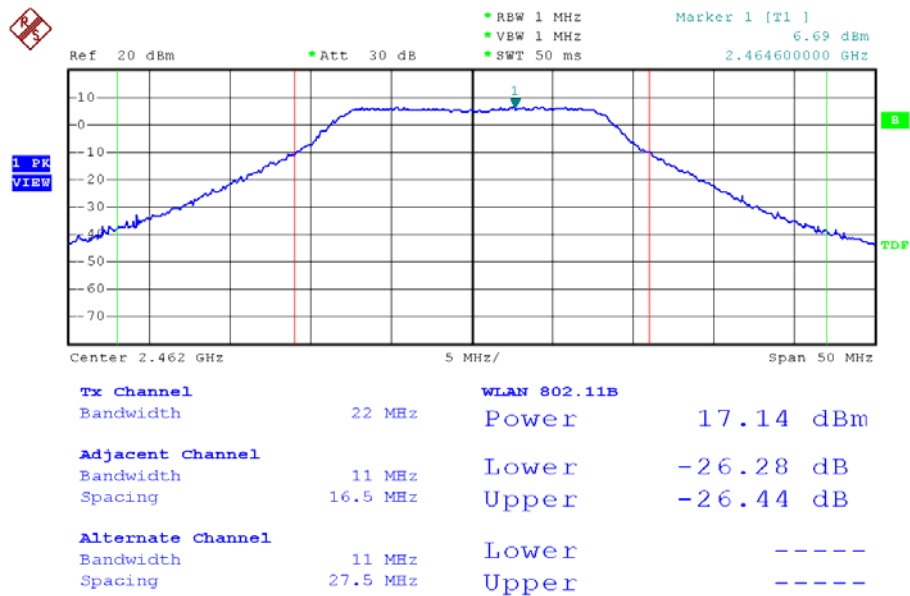





Modulation Standard: 802.11n, HT20 (6.5Mbps), Ant1  
Channel: 01

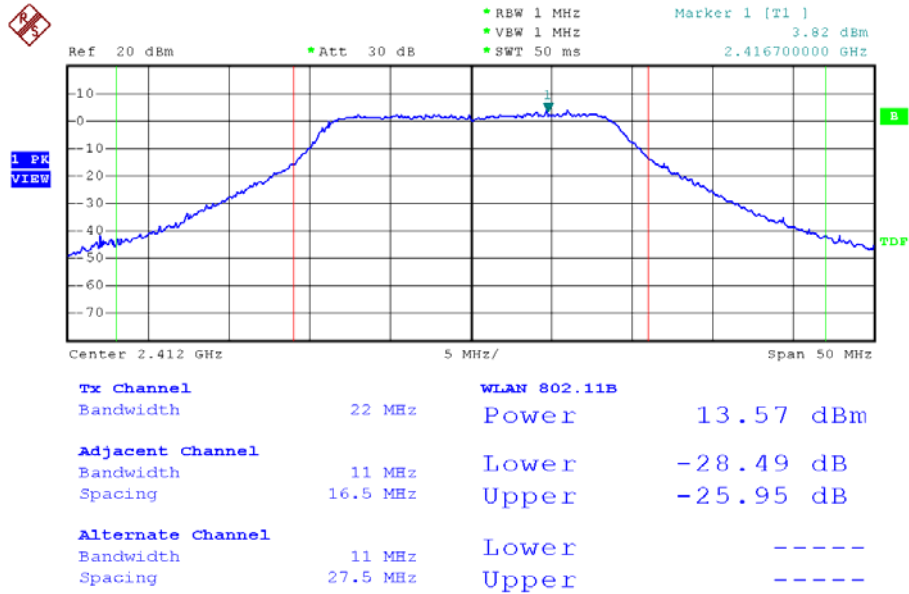

Modulation Standard: 802.11n, HT20 (6.5Mbps), Ant2  
Channel: 01

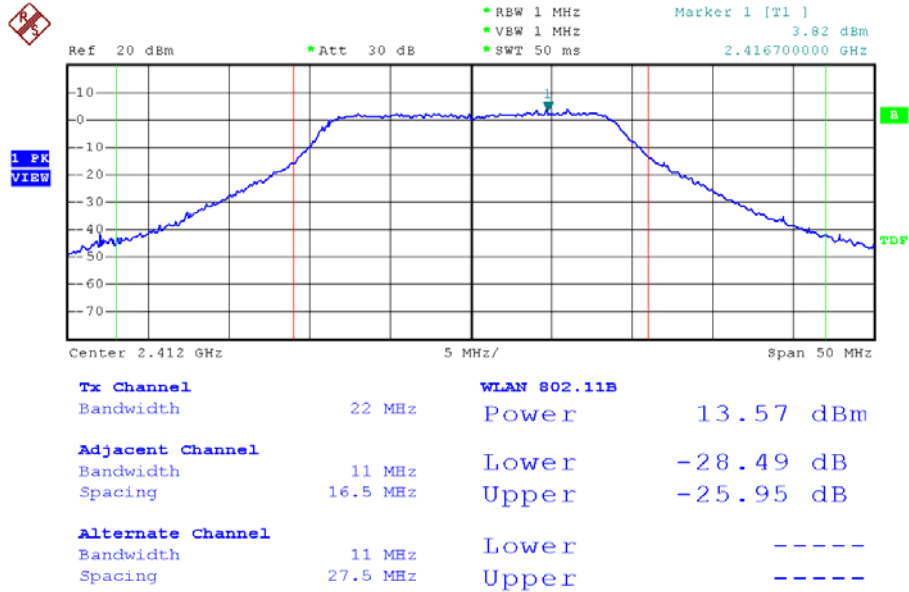



Modulation Standard: 802.11n, HT20 (6.5Mbps), Ant1  
Channel: 06

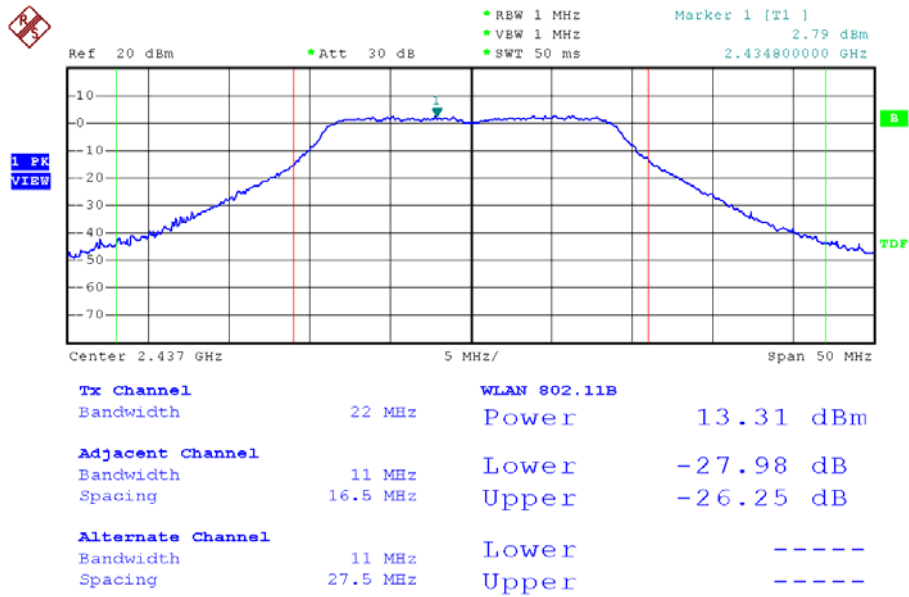

Modulation Standard: 802.11n, HT20 (6.5Mbps), Ant2  
Channel: 06

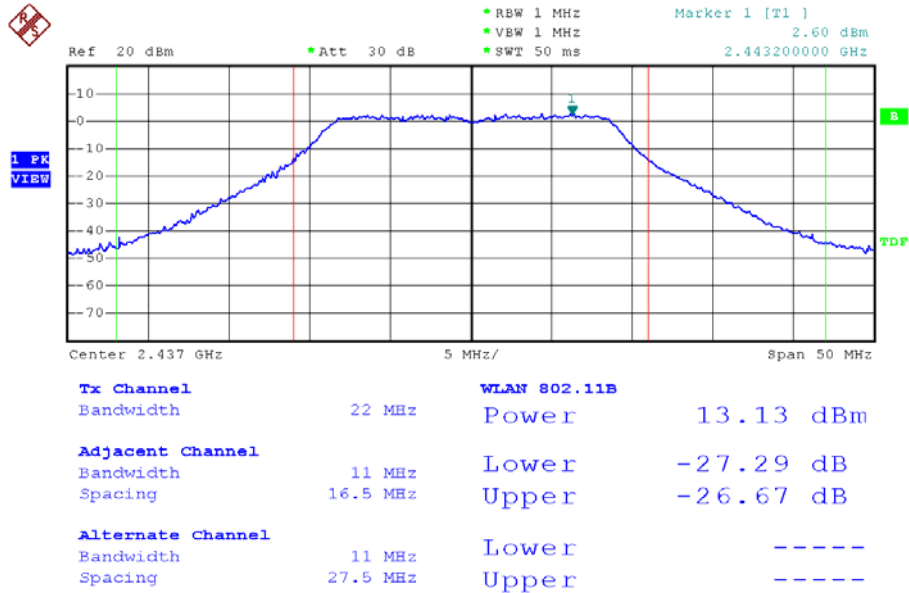



Modulation Standard: 802.11n, HT20 (6.5Mbps), Ant1  
Channel: 11

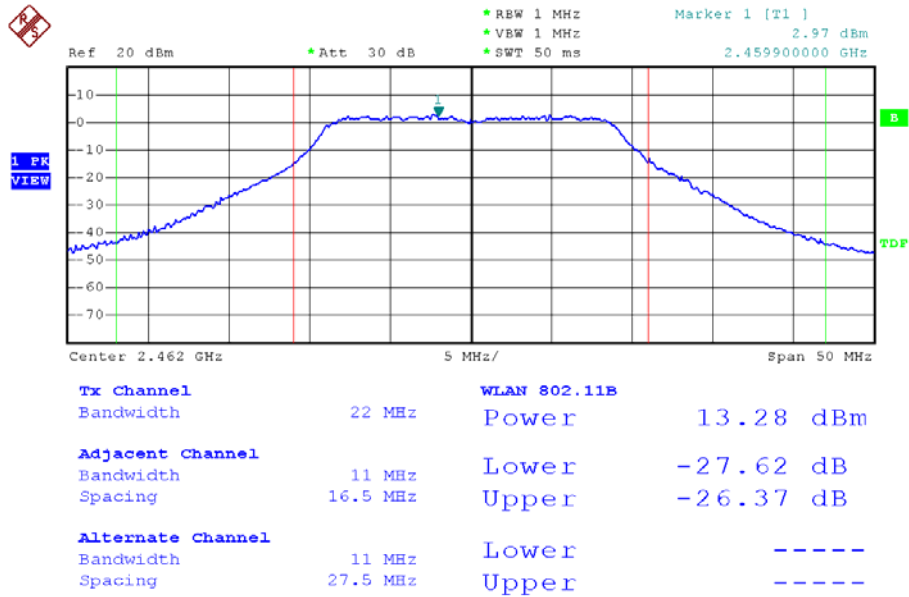

Modulation Standard: 802.11n, HT20 (6.5Mbps), Ant2  
Channel: 11

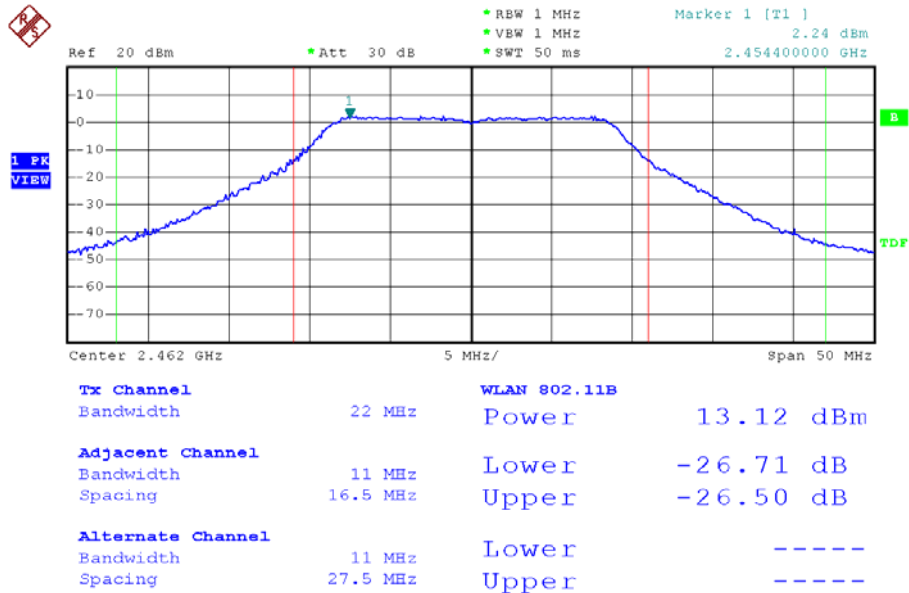



Modulation Standard: 802.11n, HT40 (13.5Mbps), Ant1  
Channel: 03

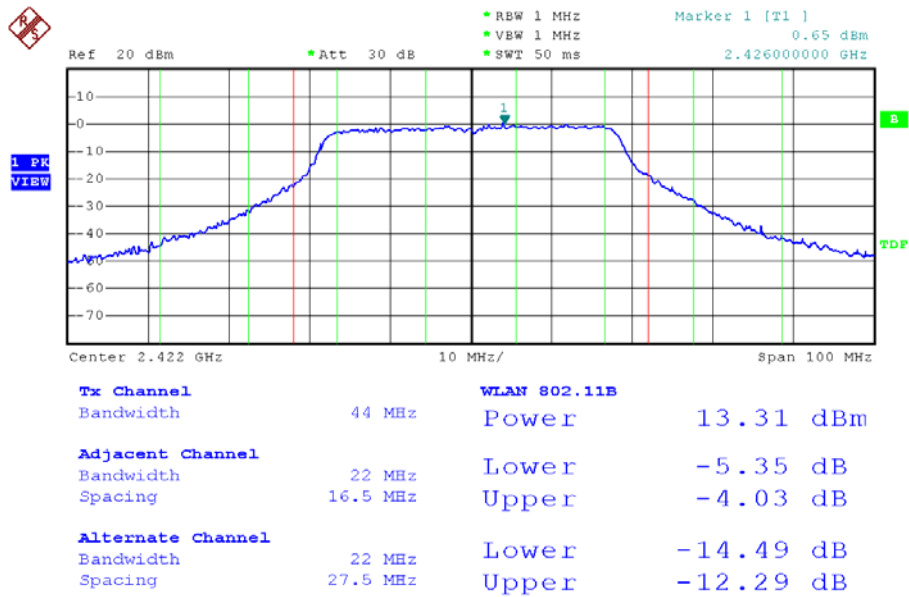

Modulation Standard: 802.11n, HT40 (13.5Mbps), Ant2  
Channel: 03

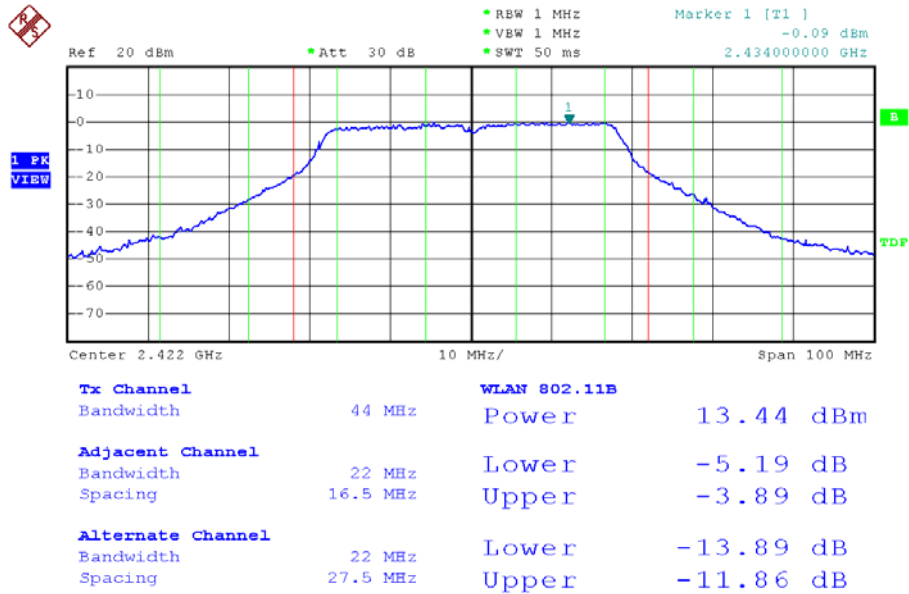



Modulation Standard: 802.11n, HT40 (13.5Mbps), Ant1  
Channel: 06

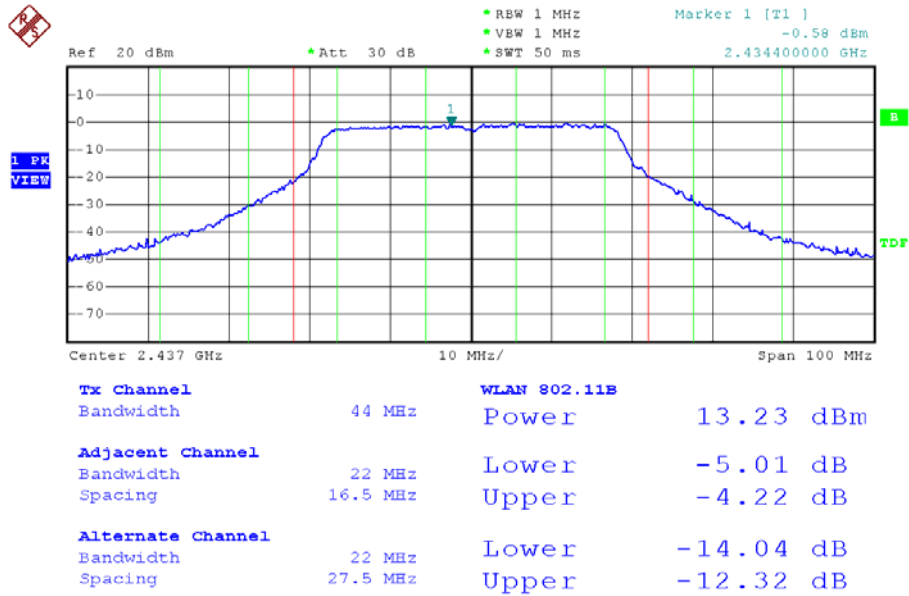

Modulation Standard: 802.11n, HT40 (13.5Mbps), Ant2  
Channel: 06

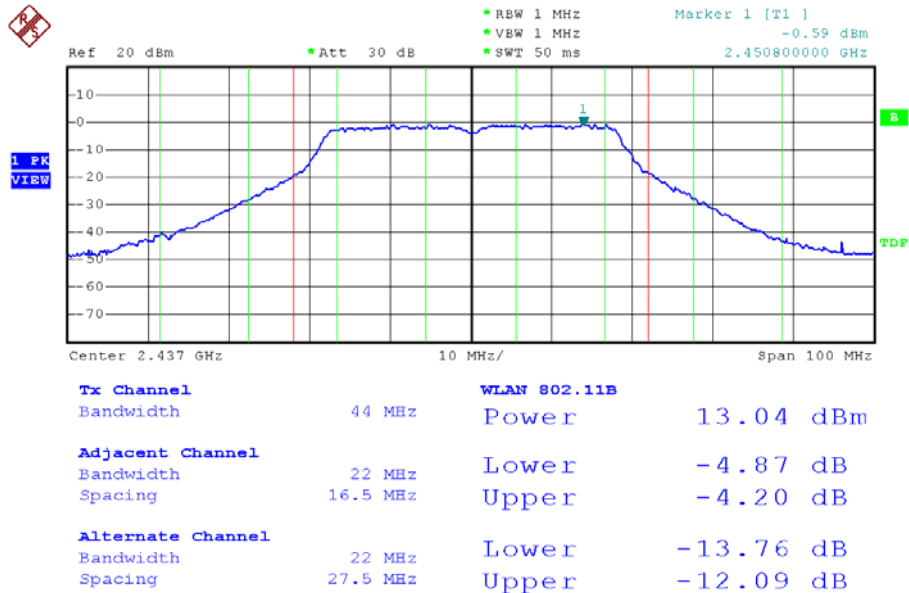



Modulation Standard: 802.11n, HT40 (13.5Mbps), Ant1  
Channel: 09

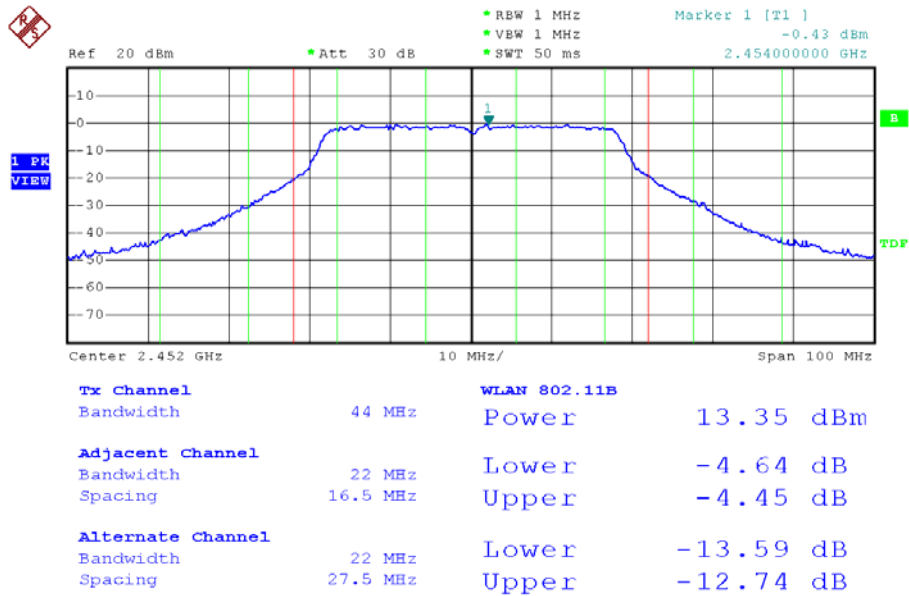

Modulation Standard: 802.11n, HT40 (13.5Mbps), Ant2  
Channel: 09

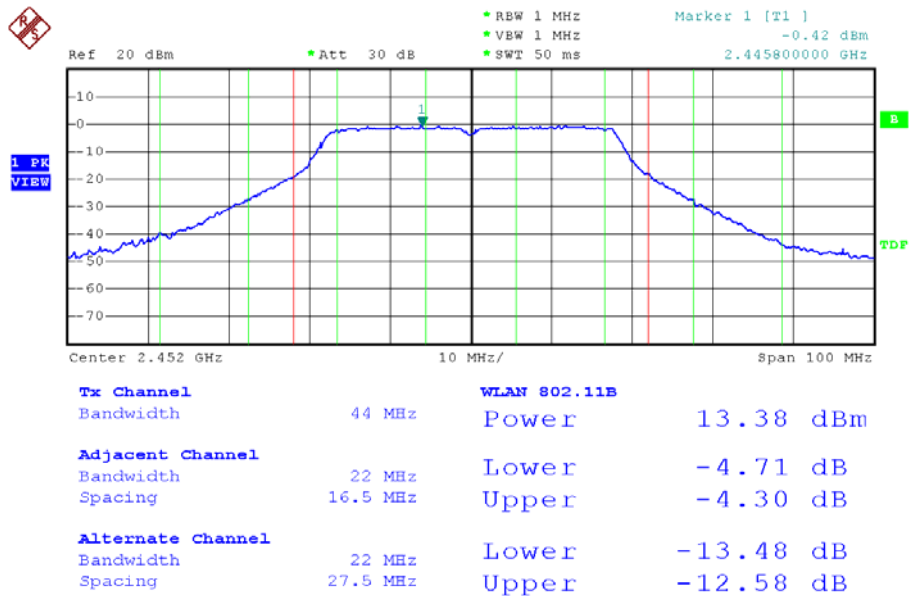



## 8. Band Edges Measurement

### 8.1 Test Limit

Below  $-20\text{dB}$  of the highest emission level of operating band (In 100 kHz Resolution Bandwidth)

### 8.2 Test Procedure

- The transmitter output was connected to the spectrum analyzer via a low lose cable.
- Set both RBW and VBW of spectrum analyzer to 100 KHz with convenient frequency span including 100 KHz bandwidth from band edge.
- The band edges was measured and recorded.

### 8.3 Test Setup Layout

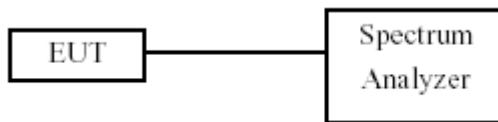

### 8.4 Measurement equipment

Instrument/Ancillary	Model No.	Manufacturer	Serial No.	Calibration Date	Valid Date
Spectrum Analyzer	FSP40	R&S	10047	2009/03/26	2010/03/25

### 8.5 Test Result and Data

Test Date: Jul. 20, 2009

Temperature: 26

Atmospheric pressure: 1012 hPa

Humidity: 64%

Modulation Standard	Channel	Frequency (MHz)	maximum value in frequency (MHz)		maximum value (dBm)	
			ANT 1	ANT 2	ANT 1	ANT 2
802.11b	01	2412	2399.6	2399.8	-40.71	-41.64
	11	2462	2501.7	3265	-55.78	-54.39
802.11g	01	2412	2400	2399.8	-34.86	-31.71
	11	2462	3265	3265	-49.05	-48.85
802.11n HT20	01	2412	2400	2400	-36.37	-35.96
	11	2462	2483.7	2484.1	-53.75	-55.03
802.11n HT40	03	2422	2399.7	2399.7	-40.28	-37.84
	09	2452	2483.5	2484.7	-49.44	-49.99



Modulation Standard: 802.11b (11Mbps), Ant1  
Channel: 01

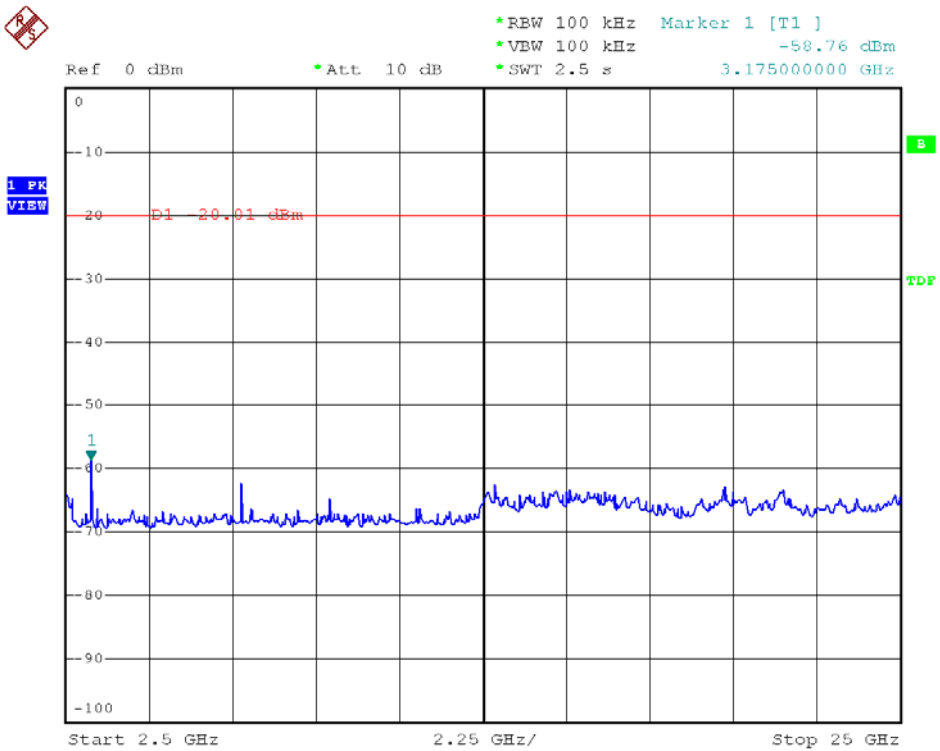
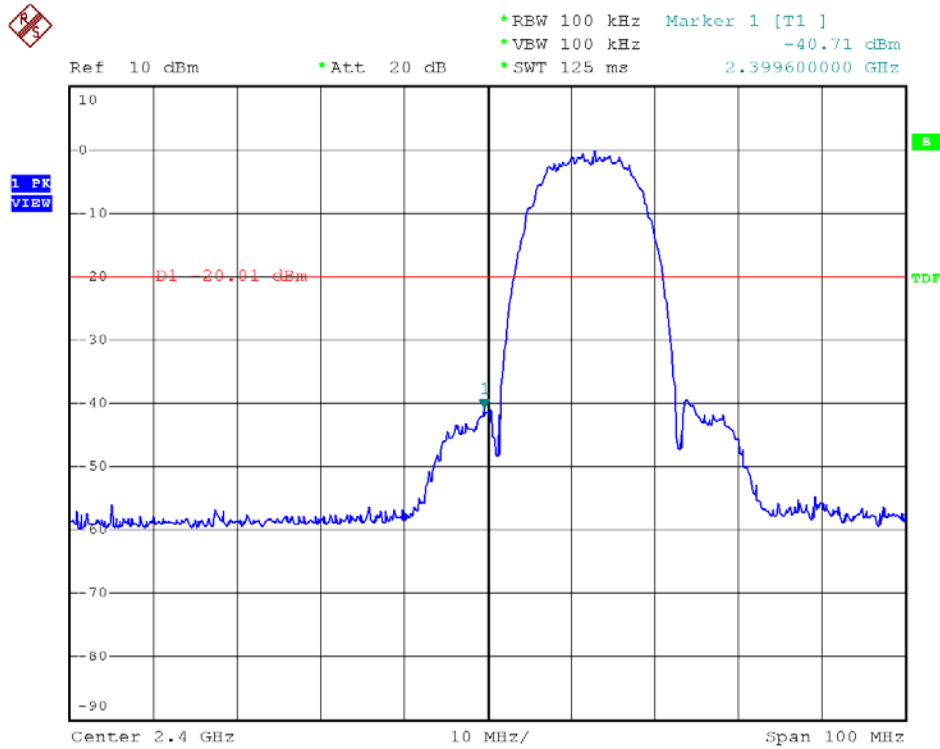





Modulation Standard: 802.11b (11Mbps), Ant2  
Channel: 01

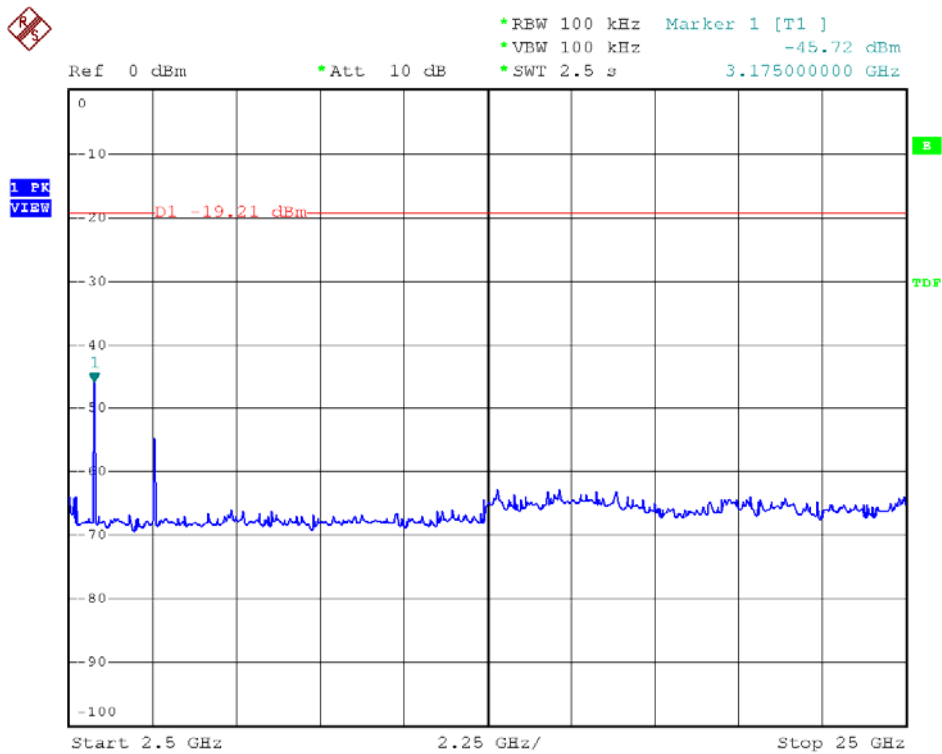
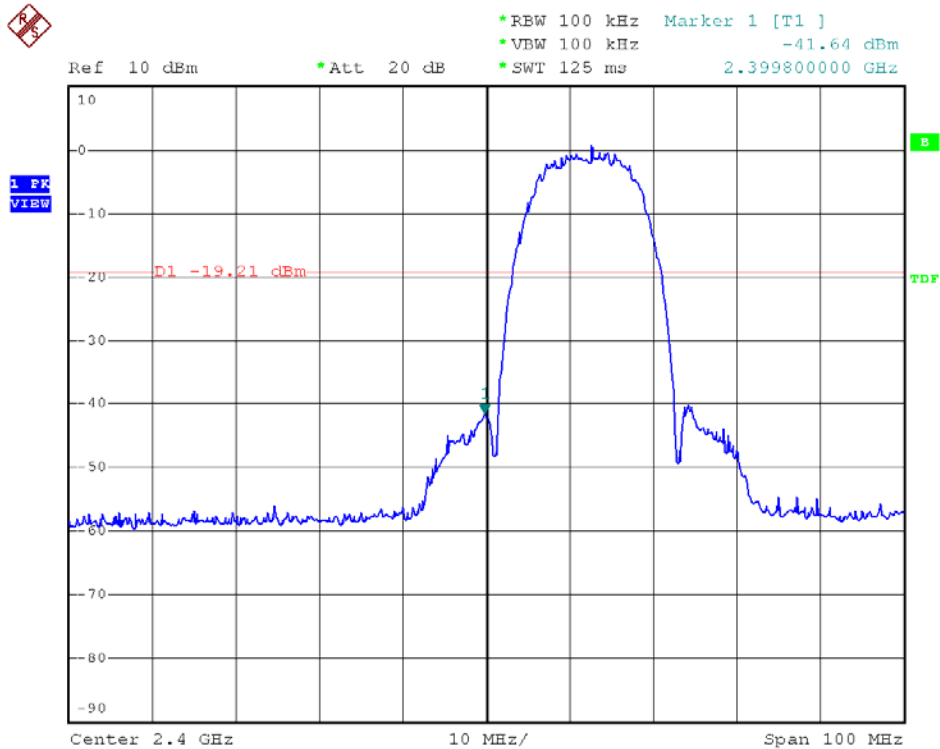



Modulation Standard: 802.11b (11Mbps), Ant1  
Channel: 11

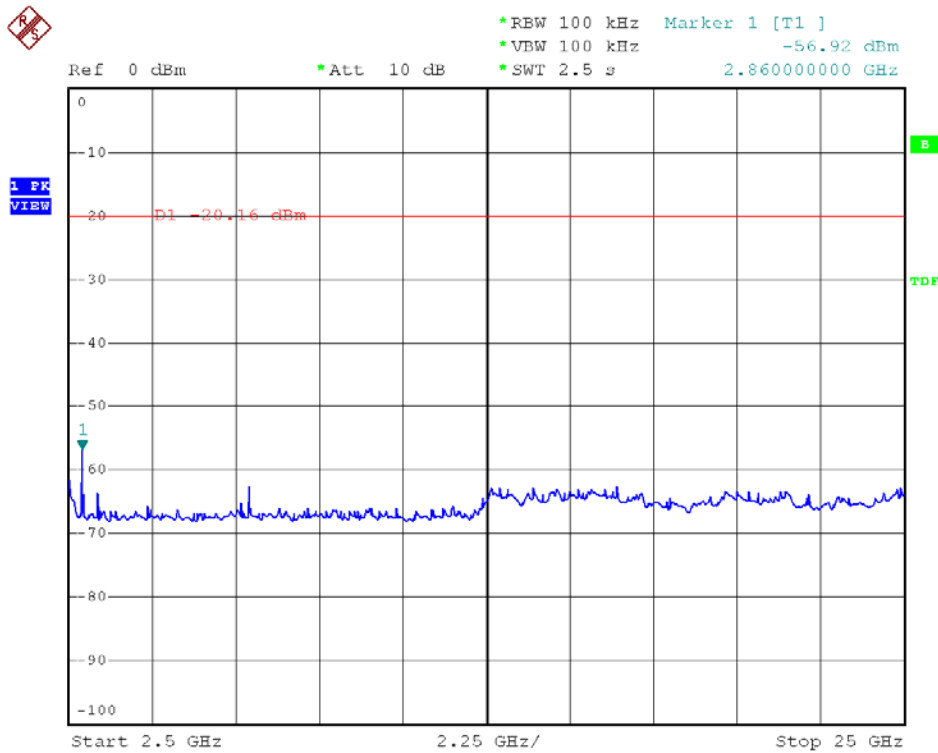
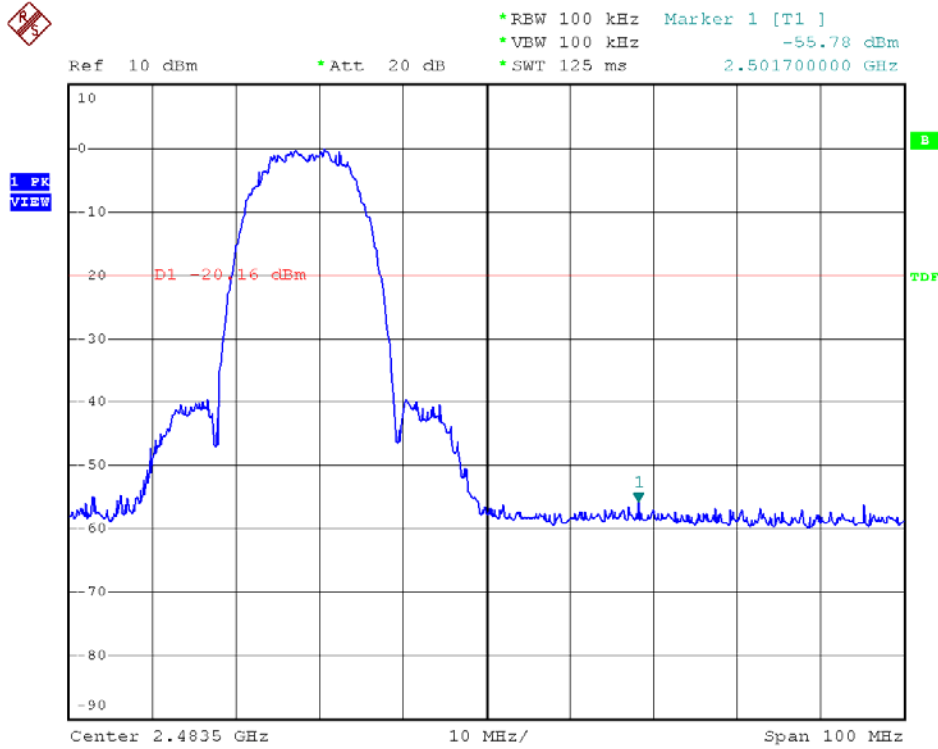



Modulation Standard: 802.11b (11Mbps), Ant2  
Channel: 11

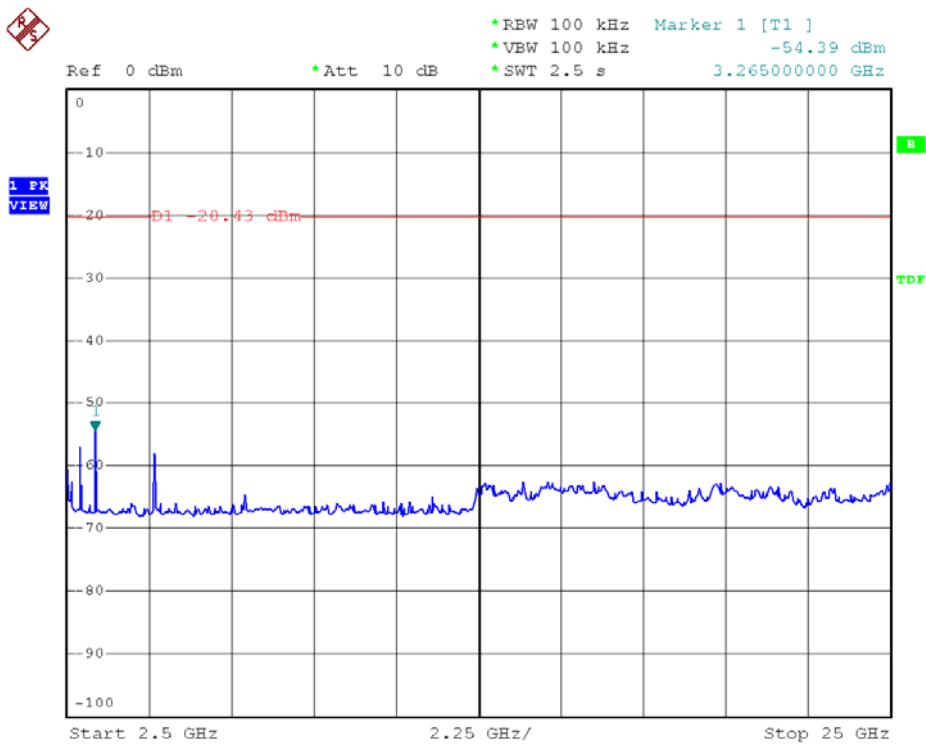
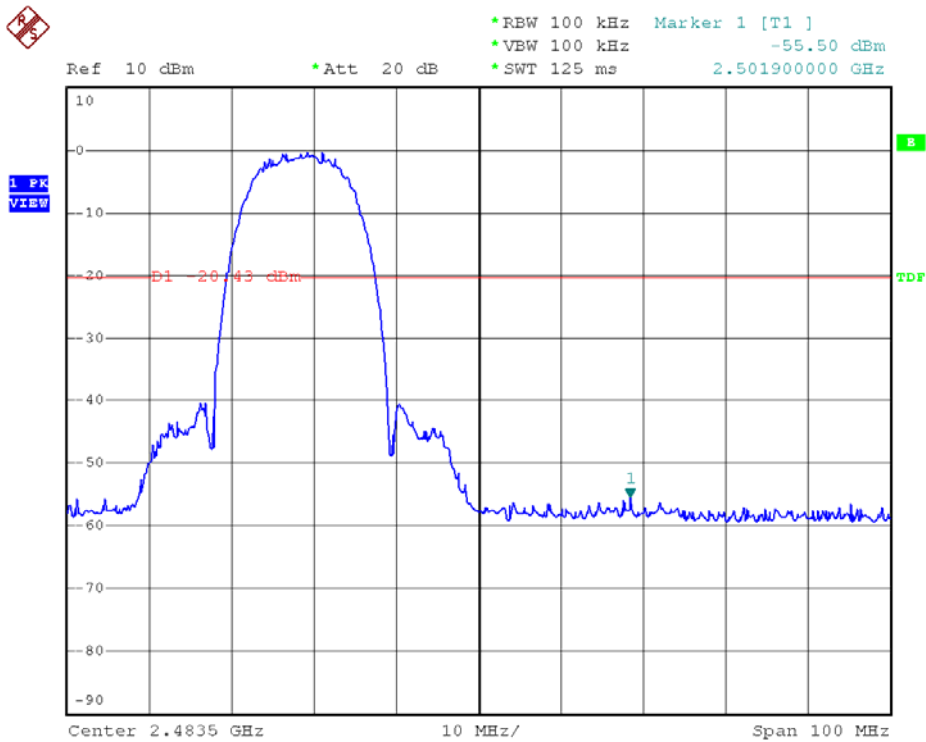



Modulation Standard: 802.11g (6Mbps), Ant1  
Channel: 01

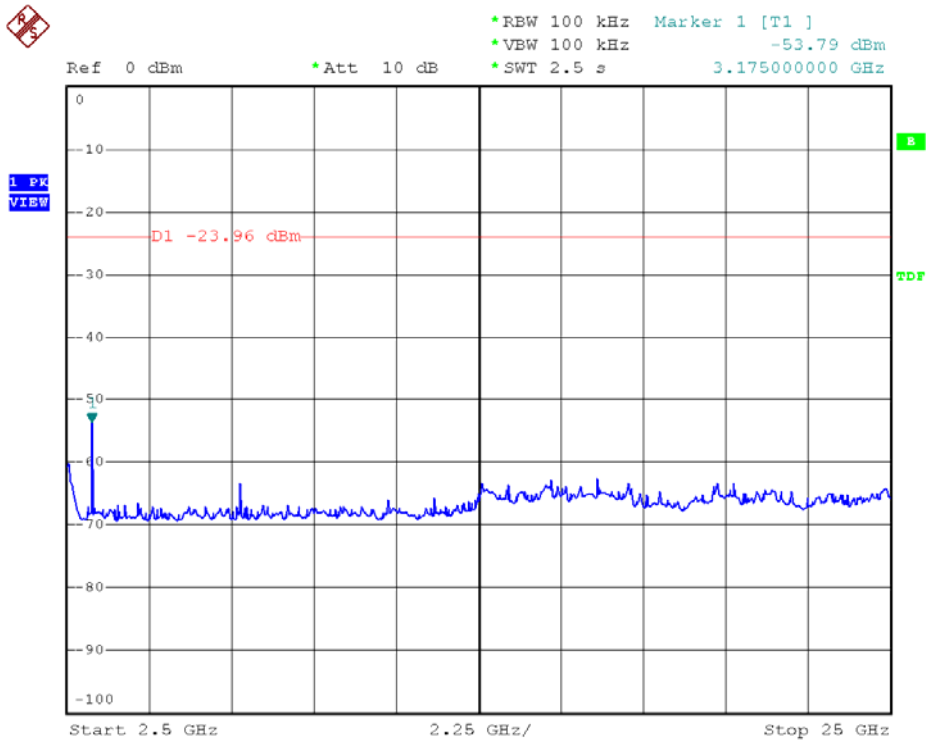
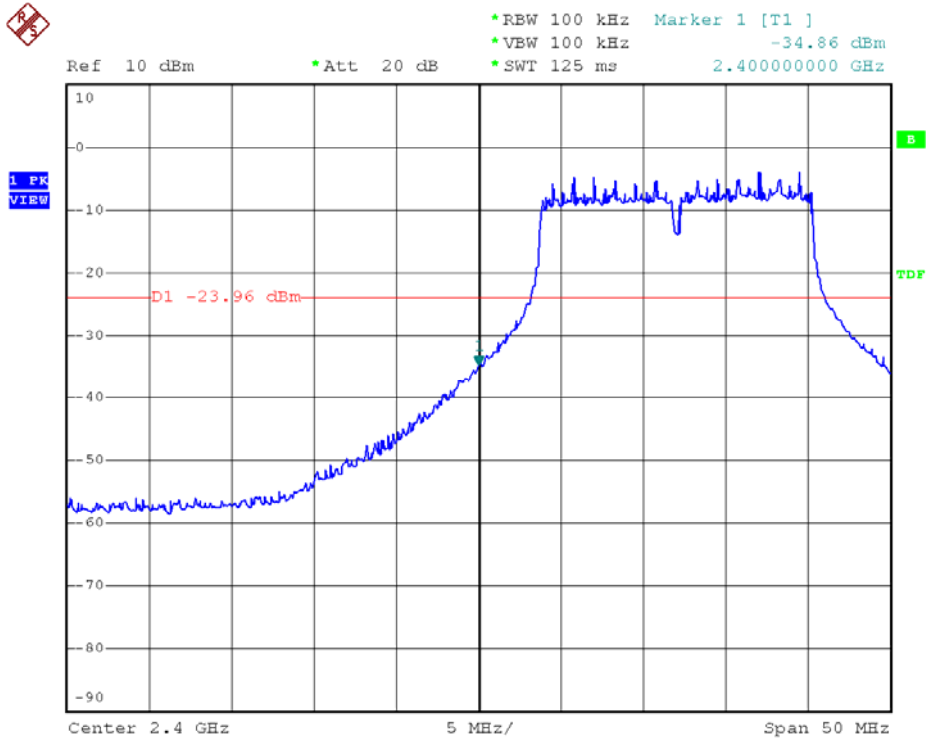



Modulation Standard: 802.11g (6Mbps), Ant2  
Channel: 01

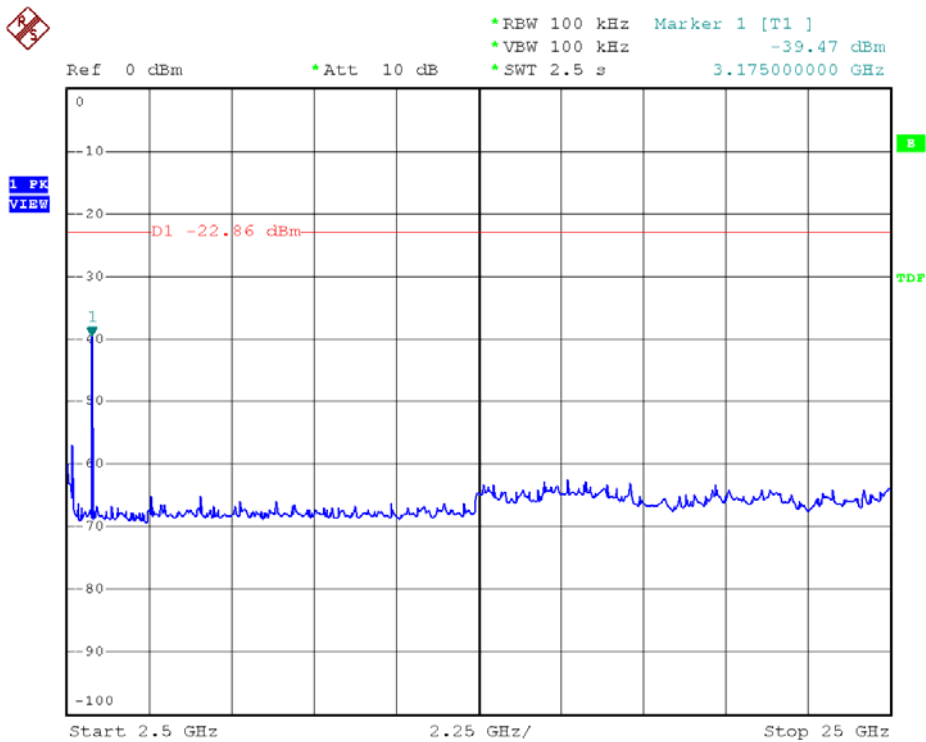
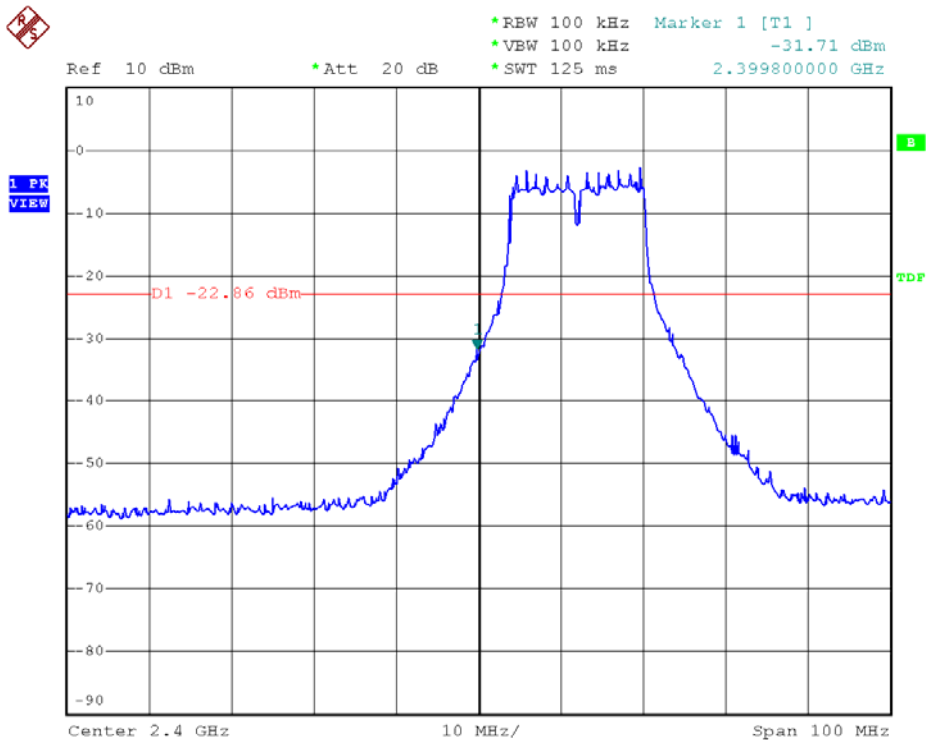



Modulation Standard: 802.11g (6Mbps), Ant1  
Channel: 11

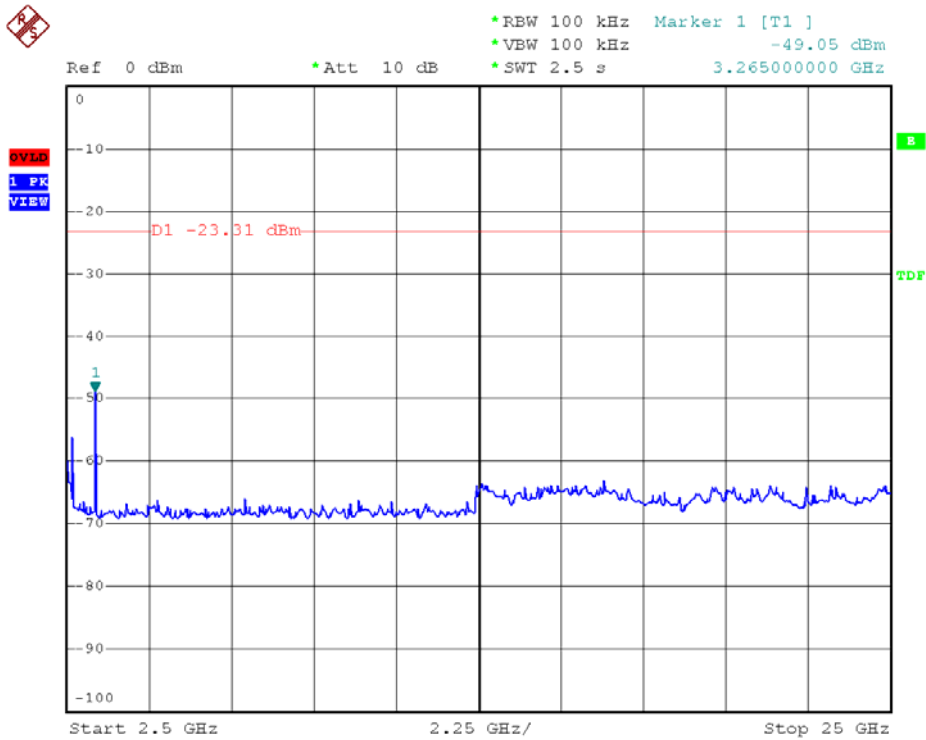
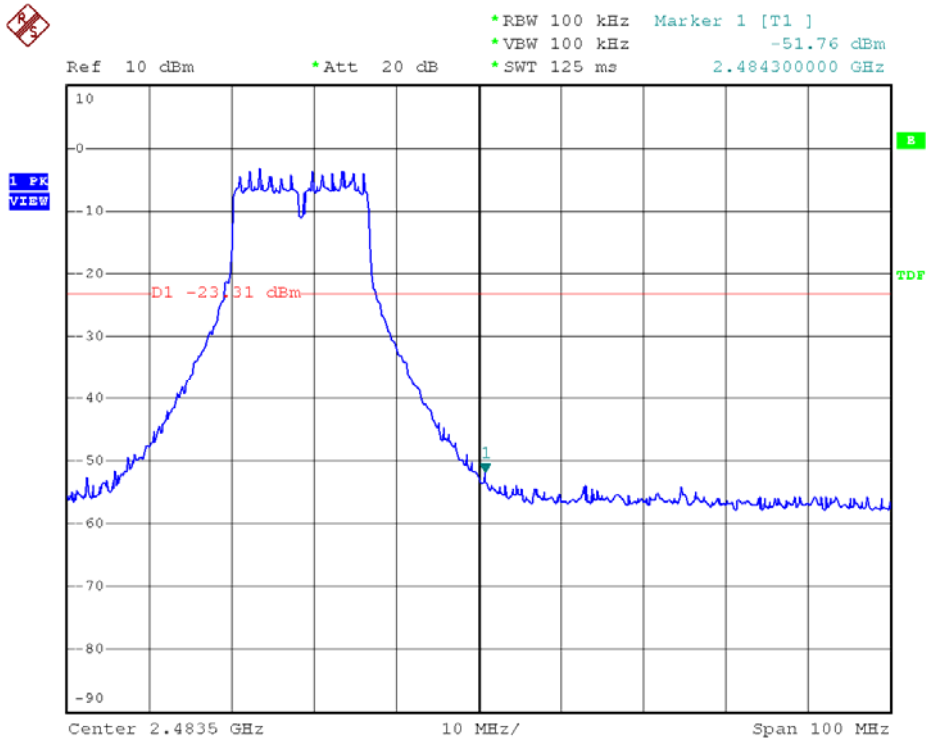



Modulation Standard: 802.11g (6Mbps), Ant2  
Channel: 11

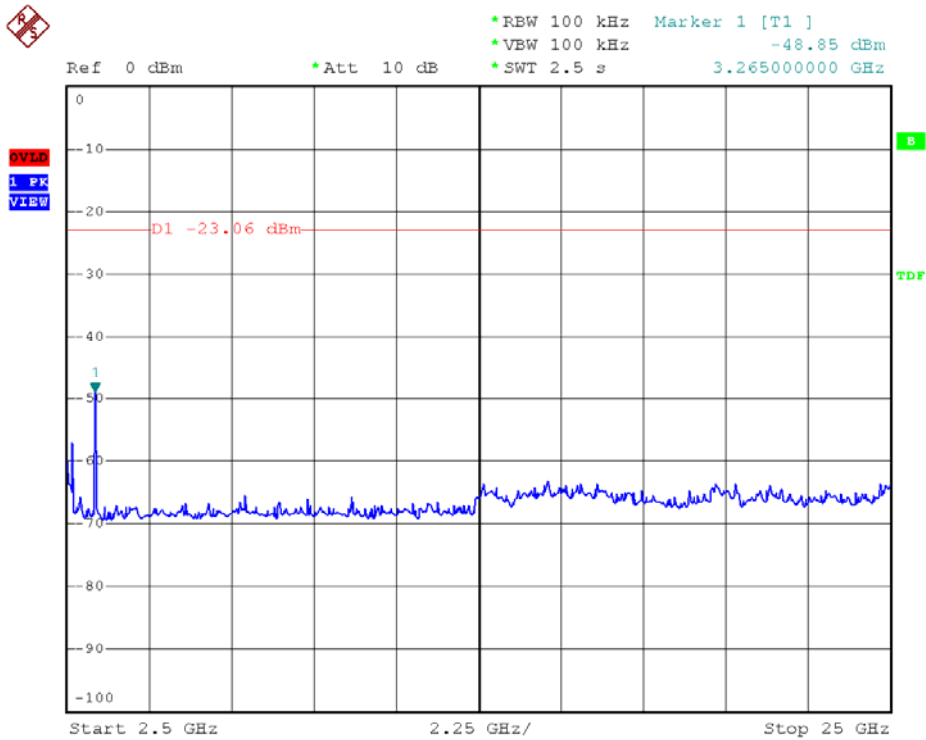
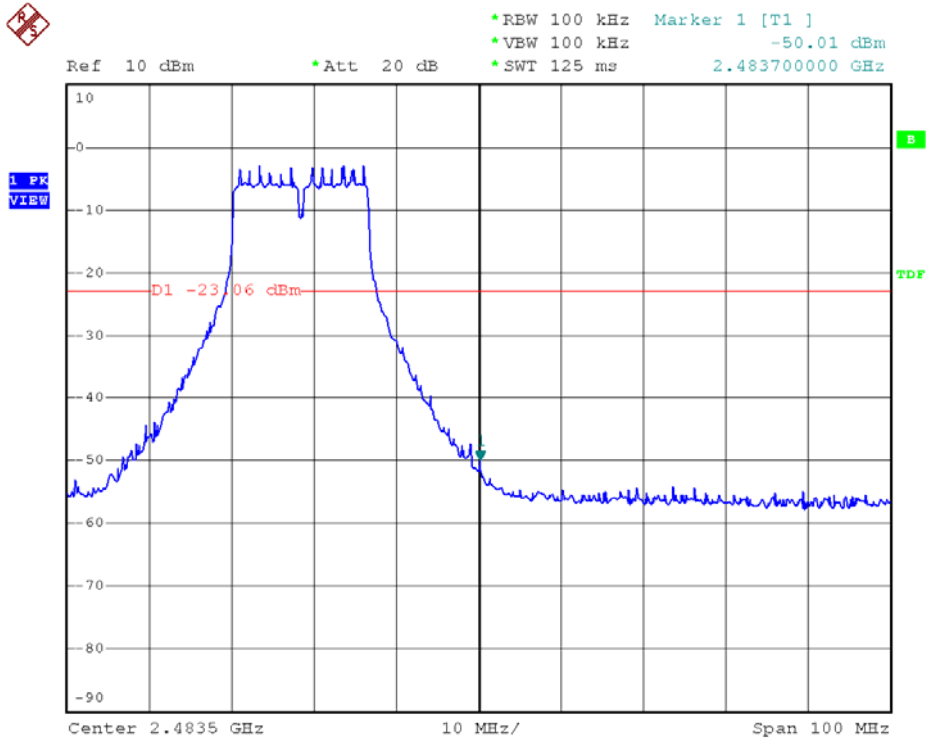



Modulation Standard: 802.11n, HT20 (6.5Mbps), Ant1  
Channel: 01

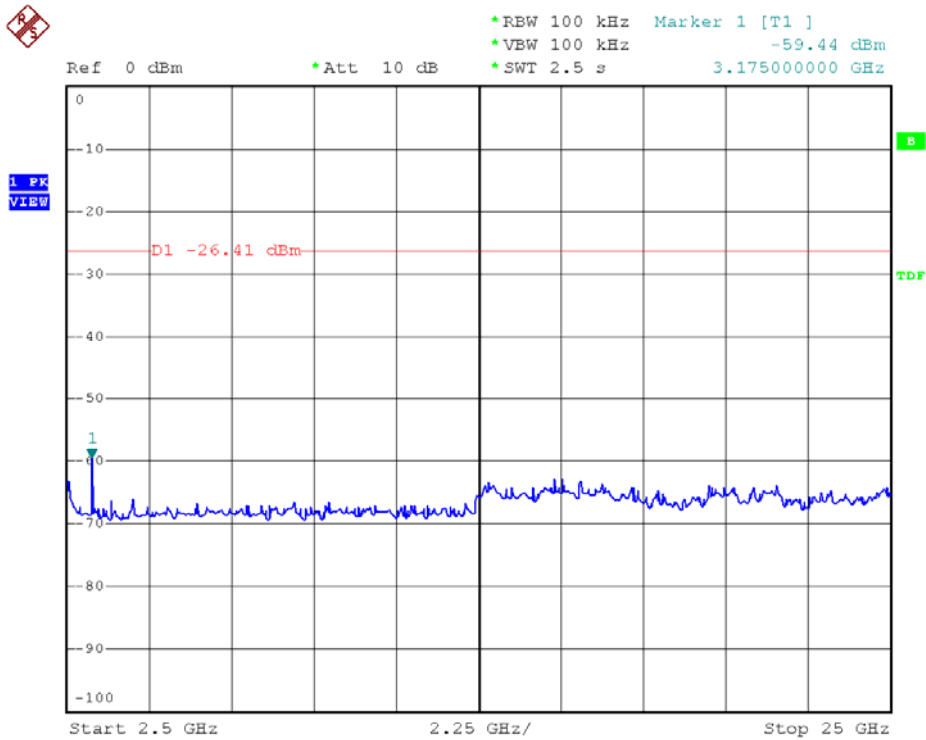
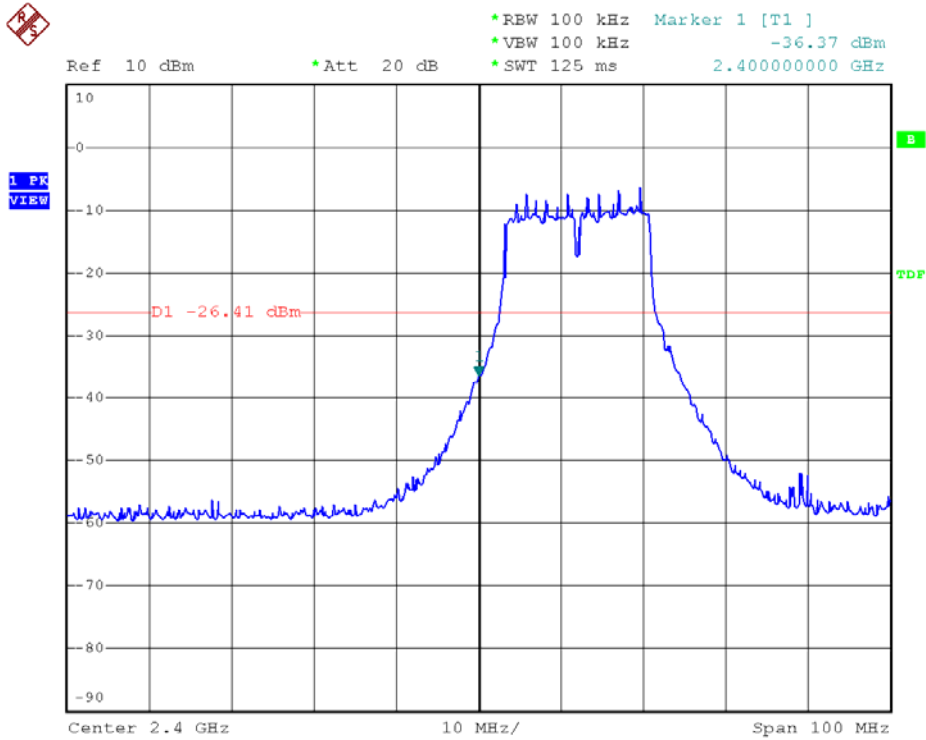





Modulation Standard: 802.11n, HT20 (6.5Mbps), Ant2  
Channel: 01

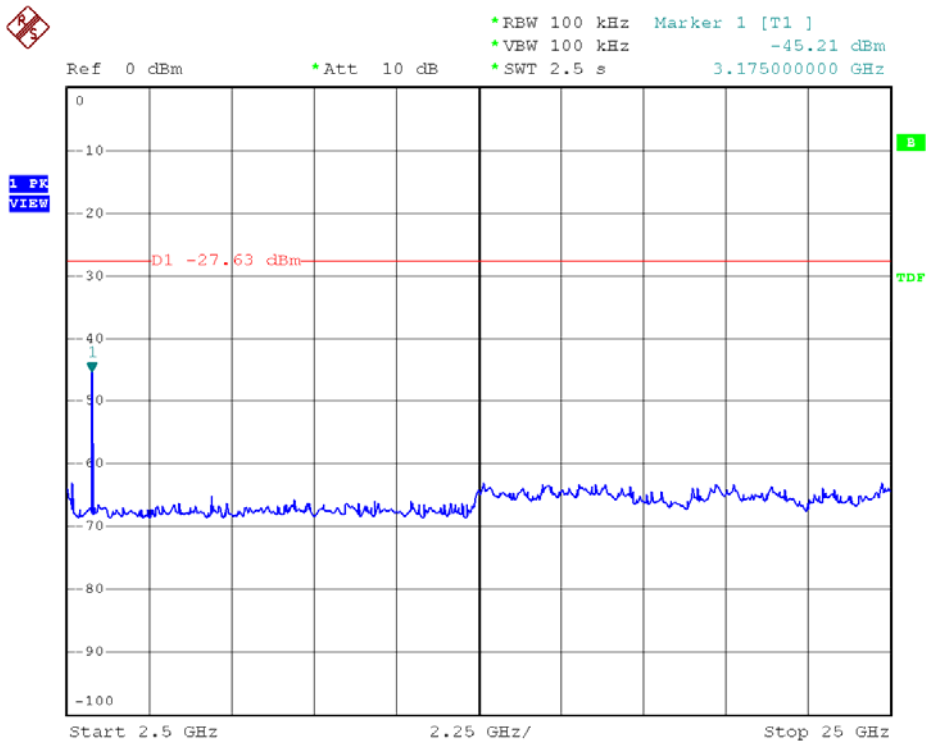
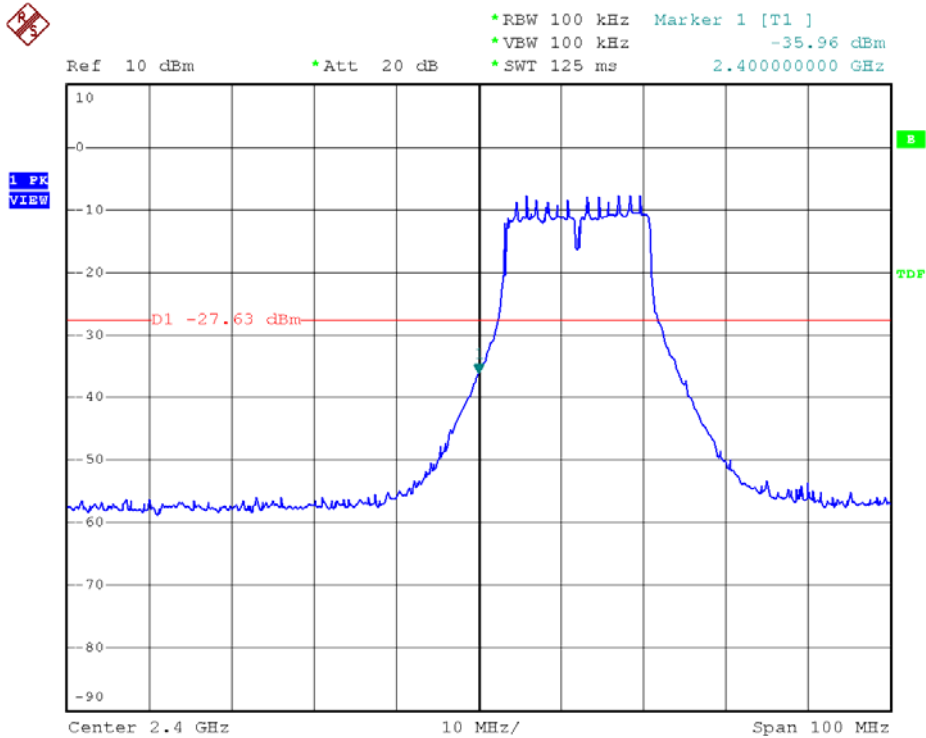



Modulation Standard: 802.11n, HT20 (6.5Mbps), Ant1  
Channel: 11

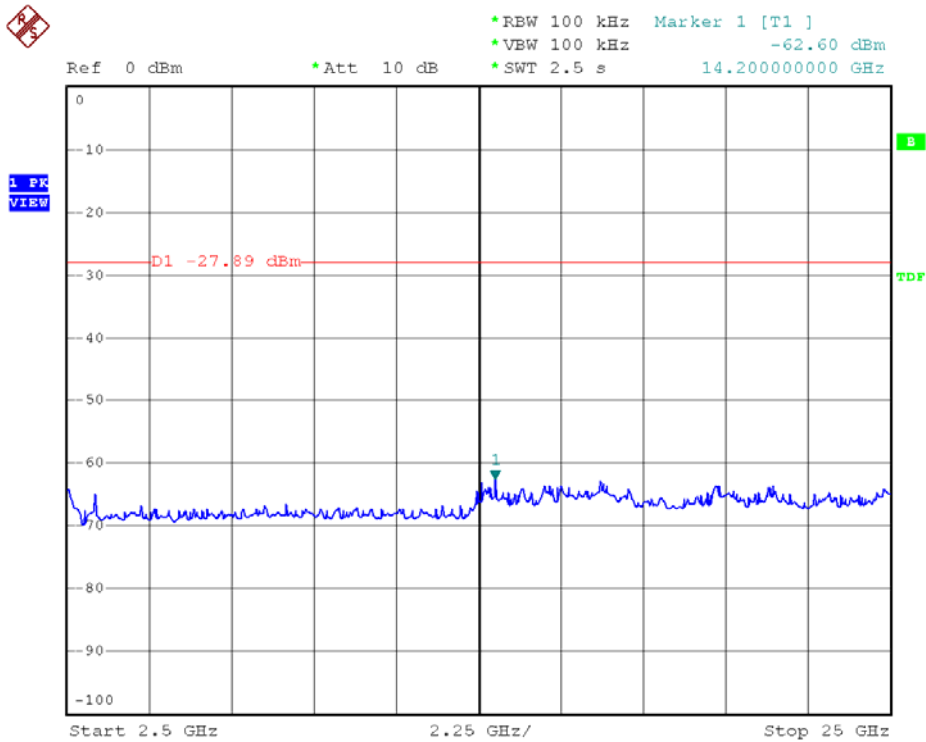
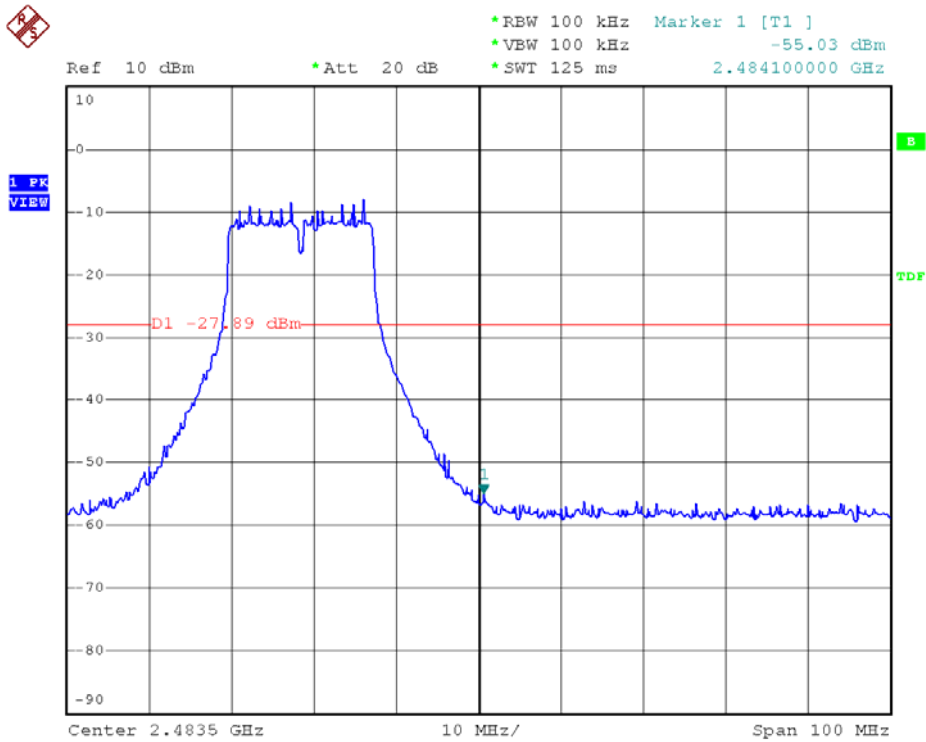



Modulation Standard: 802.11n, HT20 (6.5Mbps), Ant2  
Channel: 11

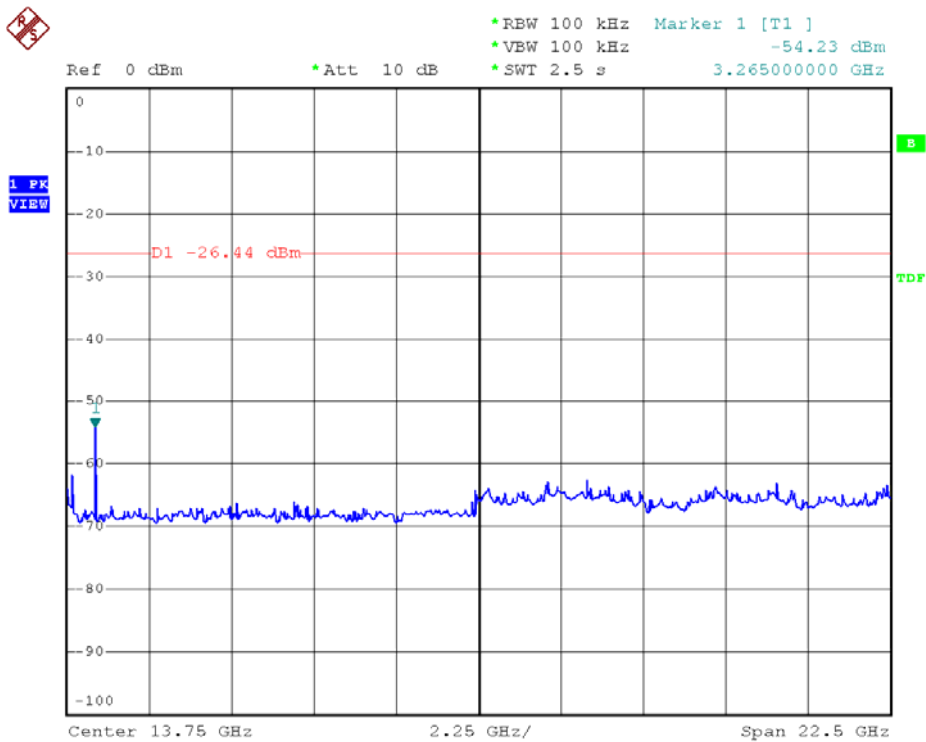
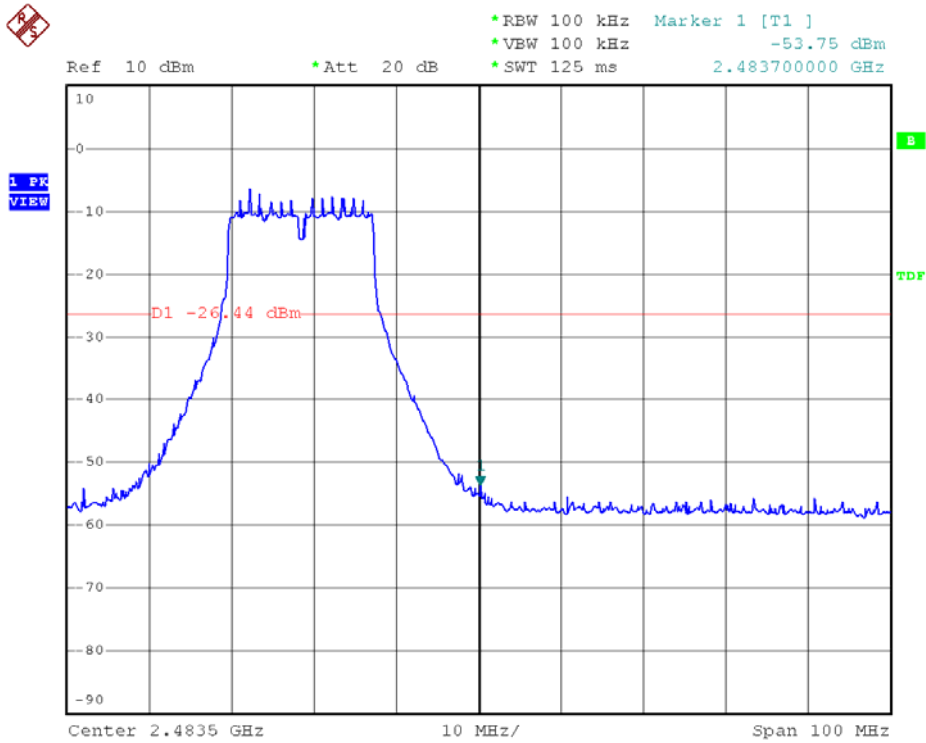



Modulation Standard: 802.11n, HT40 (13.5Mbps), Ant1  
Channel: 03

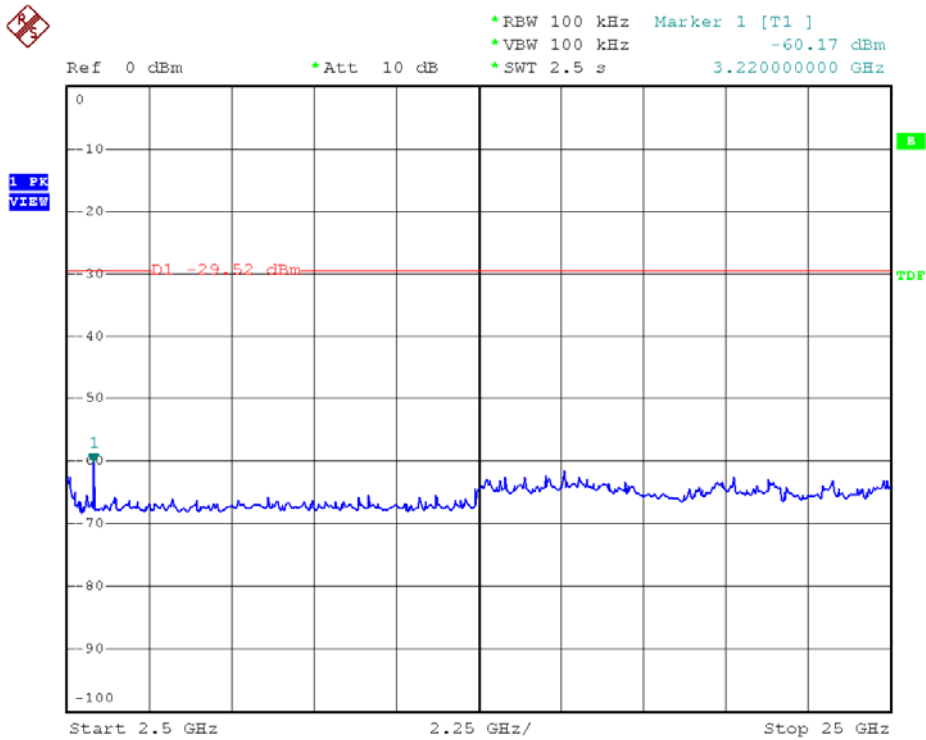
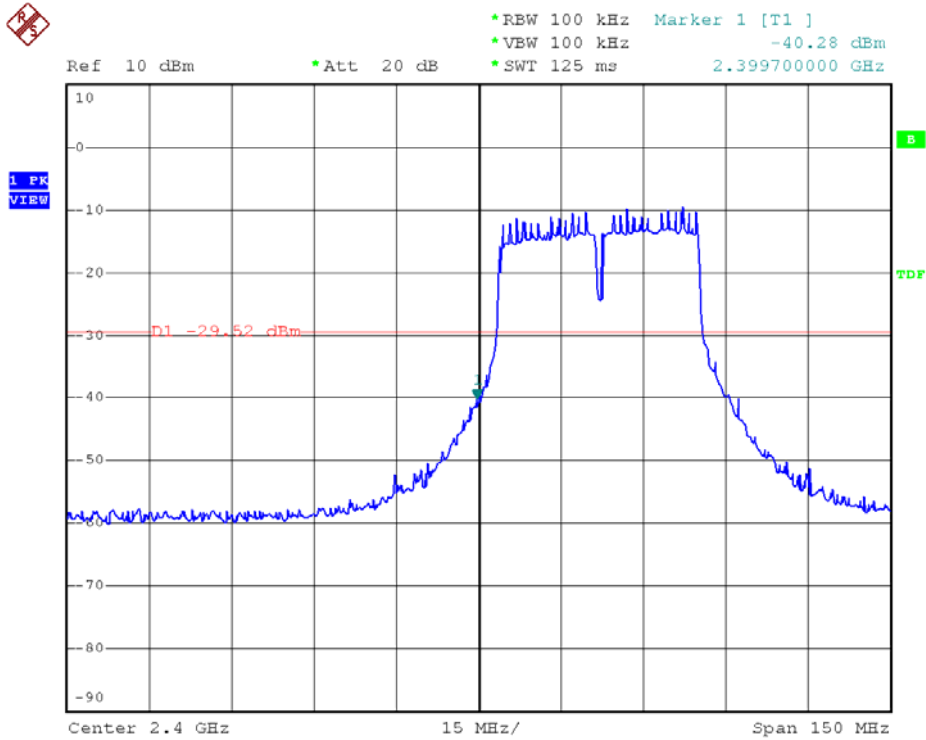



Modulation Standard: 802.11n, HT40 (13.5Mbps), Ant2  
Channel: 03

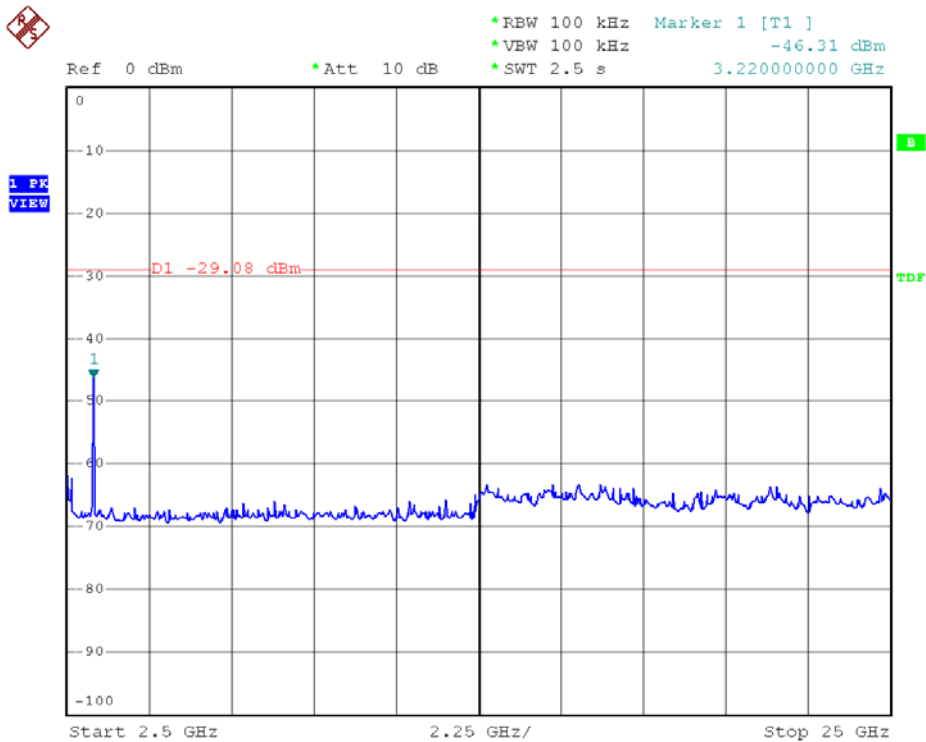
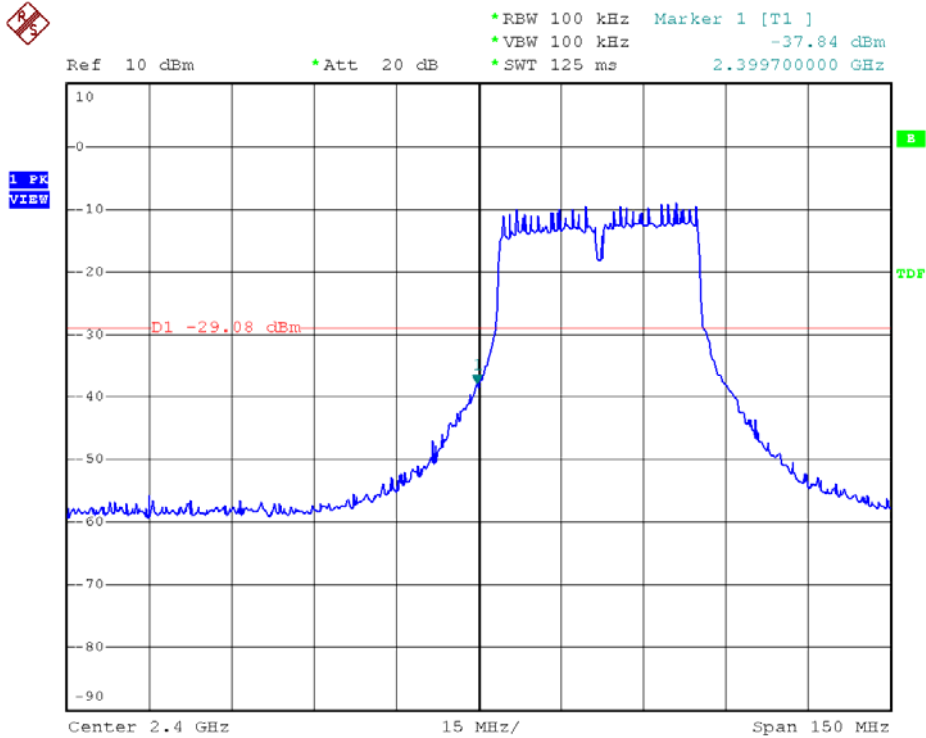



Modulation Standard: 802.11n, HT40 (13.5Mbps), Ant1  
Channel: 09

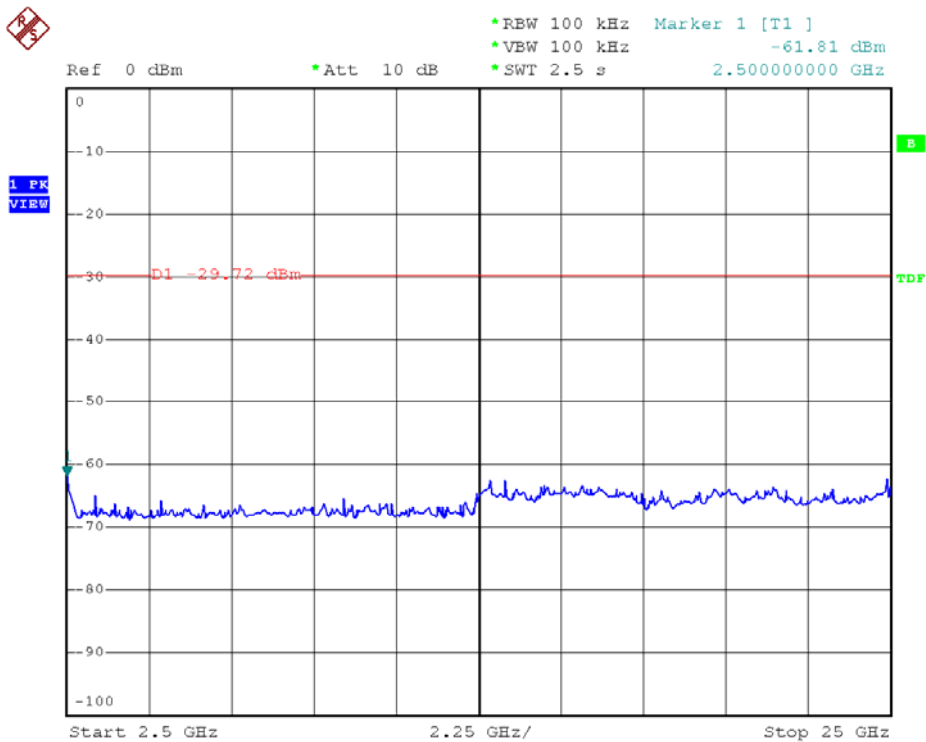
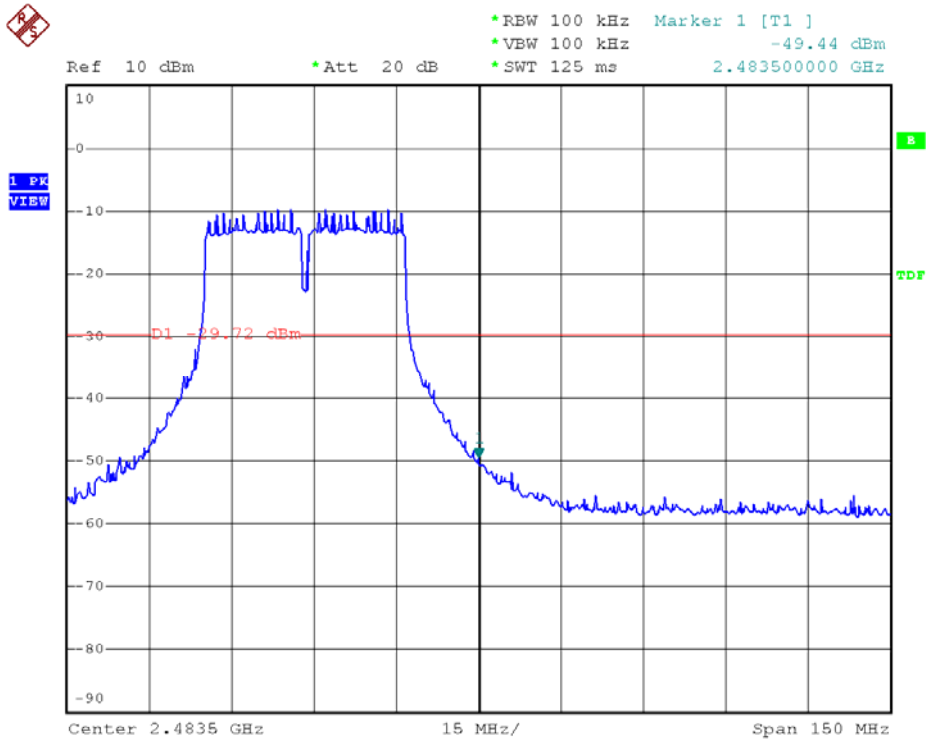



Modulation Standard: 802.11n, HT40 (13.5Mbps), Ant2  
Channel: 09

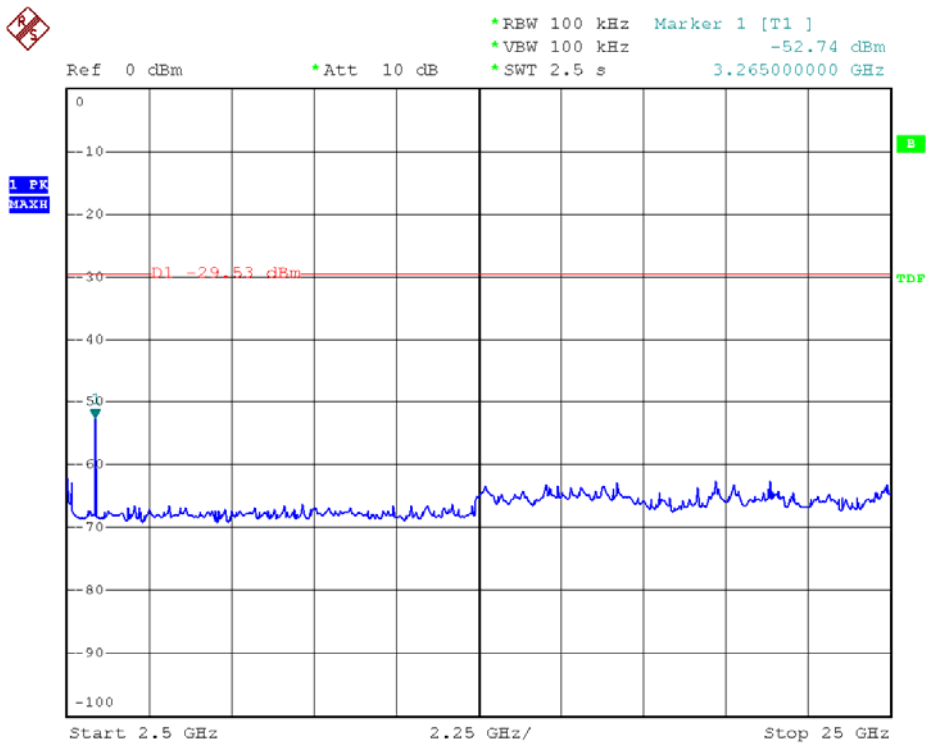
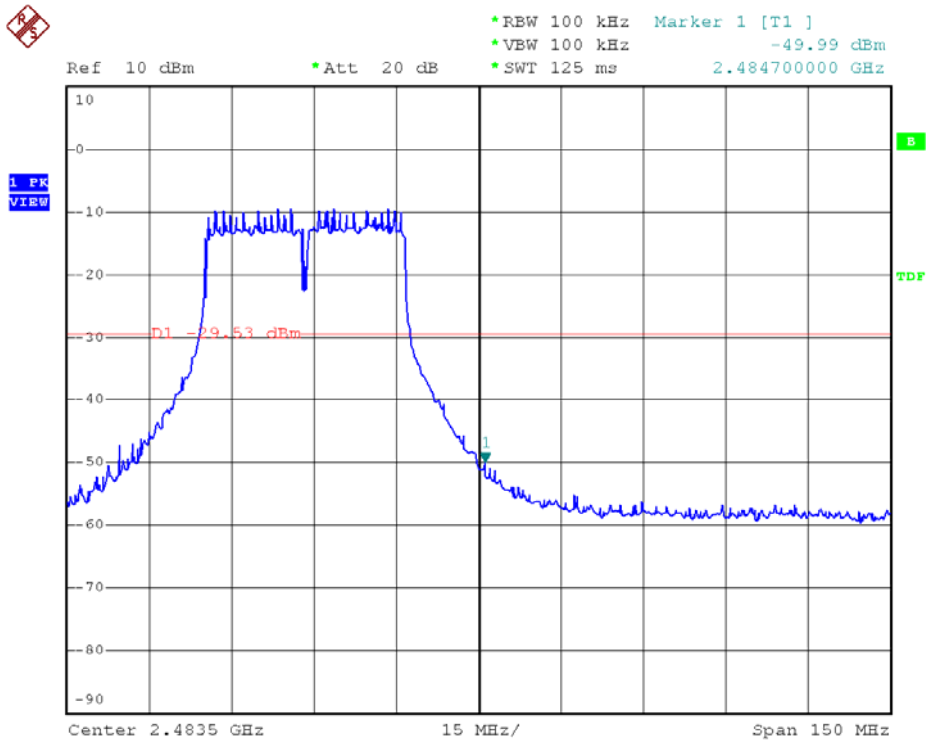

**8.6 Restrict Band Emission Measurement Data**

Test Date : Jun. 21, 2009  
 Temperature : 26  
 Humidity : 58%  
 Atmospheric Pressure : 1023 hPa  
 Adapter : FA-1201500SUA

Modulation Standard: IEEE 802.11b (11Mbps)

Channel 1						Fundamental Frequency: 2412 MHz				
Frequency (MHz)	Ant-Pol H/V	Meter Reading	Corrected Factor	Result (dBuV/m)	Remark	Limit@3m (dBuV/m)		Margin (dB)	Table (Deg.)	Ant High (m)
						Peak	Ave.			
2378.95	H	48.20	-2.96	45.24	Peak	74	54	-28.76	218	1
2390.00	H	34.21	-2.92	31.29	Ave	74	54	-22.71	218	1
2386.60	V	48.48	-2.93	45.55	Peak	74	54	-28.45	240	1
2390.00	V	34.61	-2.92	31.69	Ave	74	54	-22.31	240	1
Channel 11						Fundamental Frequency: 2462 MHz				
2485.86	H	48.87	-2.56	46.31	Peak	74	54	-27.69	217	1
2483.50	H	34.85	-2.56	32.29	Ave	74	54	-21.71	217	1
2489.55	V	50.73	-2.54	48.19	Peak	74	54	-25.81	238	1
2483.50	V	36.61	-2.56	34.05	Ave	74	54	-19.95	238	1

Modulation Standard: IEEE 802.11g (6Mbps)

Channel 1						Fundamental Frequency: 2412 MHz				
Frequency (MHz)	Ant-Pol H/V	Meter Reading	Corrected Factor	Result (dBuV/m)	Remark	Limit@3m (dBuV/m)		Margin (dB)	Table (Deg.)	Ant High (m)
						Peak	Ave.			
2389.87	H	55.20	-2.92	52.28	Peak	74	54	-21.72	219	1
2390.00	H	36.80	-2.92	33.88	Ave	74	54	-20.12	219	1
2389.66	V	57.78	-2.92	54.86	Peak	74	54	-19.14	239	1
2390.00	V	38.06	-2.92	35.14	Ave	74	54	-18.86	239	1
Channel 11						Fundamental Frequency: 2462 MHz				
2483.58	H	56.05	-2.56	53.49	Peak	74	54	-20.51	212	1
2483.50	H	38.24	-2.56	35.68	Ave	74	54	-18.32	212	1
2483.74	V	60.19	-2.56	57.63	Peak	74	54	-16.37	234	1
2483.50	V	41.31	-2.56	38.75	Ave	74	54	-15.25	234	1

Notes:

1. Result = Meter Reading + Factor
2. Factor = Antenna Factor + Cable Loss – Amplifier
3. The resolution bandwidth of test receiver/spectrum analyzer is 1 MHz and video bandwidth is 3 MHz for Peak detection at frequency above 1GHz.
4. The resolution bandwidth of test receiver/spectrum analyzer is 1MHz and video bandwidth is 10Hz for Average detection at frequency above 1GHz





Test Date : Jun. 21, 2009  
 Temperature : 26  
 Humidity : 58%  
 Atmospheric Pressure : 1023 hPa  
 Adapter : FA-1201500SUA

Modulation Standard: IEEE 802.11n, HT20 (6.5Mbps)

Channel 1						Fundamental Frequency: 2412 MHz				
Frequency (MHz)	Ant-Pol H/V	Meter Reading	Corrected Factor	Result (dBuV/m)	Remark	Limit@3m (dBuV/m)		Margin (dB)	Table (Deg.)	Ant High (m)
						Peak	Ave.			
2389.87	H	49.81	-2.92	46.89	Peak	74	54	-27.11	222	1
2390.00	H	34.96	-2.92	32.04	Ave	74	54	-21.96	222	1
2389.66	V	52.39	-2.92	49.47	Peak	74	54	-24.53	233	1
2390.00	V	36.04	-2.92	33.12	Ave	74	54	-20.88	233	1
Channel 11						Fundamental Frequency: 2462 MHz				
2483.62	H	52.72	-2.56	50.16	Peak	74	54	-23.84	209	1
2483.50	H	35.13	-2.56	32.57	Ave	74	54	-21.43	209	1
2483.58	V	54.74	-2.56	52.18	Peak	74	54	-21.82	241	1
2483.50	V	37.02	-2.56	34.46	Ave	74	54	-19.54	241	1

Modulation Standard: IEEE 802.11n, HT40 (13.5Mbps)

Channel 3						Fundamental Frequency: 2422 MHz				
Frequency (MHz)	Ant-Pol H/V	Meter Reading	Corrected Factor	Result (dBuV/m)	Remark	Limit@3m (dBuV/m)		Margin (dB)	Table (Deg.)	Ant High (m)
						Peak	Ave.			
2389.36	H	56.58	-2.92	53.66	Peak	74	54	-20.34	223	1
2390.00	H	37.87	-2.92	34.95	Ave	74	54	-19.05	223	1
2389.36	V	59.33	-2.92	56.41	Peak	74	54	-17.59	232	1
2390.00	V	39.45	-2.92	36.53	Ave	74	54	-17.47	232	1
Channel 9						Fundamental Frequency: 2452 MHz				
2484.04	H	60.09	-2.56	57.53	Peak	74	54	-16.47	213	1
2483.50	H	39.73	-2.56	37.17	Ave	74	54	-16.83	213	1
2483.70	V	64.34	-2.56	61.78	Peak	74	54	-12.22	236	1
2483.50	V	43.25	-2.56	40.69	Ave	74	54	-13.31	236	1

Notes:

1. Result = Meter Reading + Factor
2. Factor = Antenna Factor + Cable Loss – Amplifier
3. The resolution bandwidth of test receiver/spectrum analyzer is 1 MHz and video bandwidth is 3 MHz for Peak detection at frequency above 1GHz.
4. The resolution bandwidth of test receiver/spectrum analyzer is 1MHz and video bandwidth is 10Hz for Average detection at frequency above 1GHz



Test Date : Jun. 21, 2009  
 Temperature : 26  
 Humidity : 58%  
 Atmospheric Pressure : 1023 hPa  
 Adapter : AD661F0916BLF

Modulation Standard: IEEE 802.11b (11Mbps)

Channel 1						Fundamental Frequency: 2412 MHz				
Frequency (MHz)	Ant-Pol H/V	Meter Reading	Corrected Factor	Result (dBuV/m)	Remark	Limit@3m (dBuV/m)		Margin (dB)	Table (Deg.)	Ant High (m)
						Peak	Ave.			
2378.88	H	47.33	-2.96	44.37	Peak	74	54	-29.63	215	1
2390.00	H	34.95	-2.92	32.03	Ave	74	54	-21.97	215	1
2386.52	V	47.25	-2.93	44.32	Peak	74	54	-29.68	236	1
2390.00	V	35.28	-2.92	32.36	Ave	74	54	-21.64	236	1
Channel 11						Fundamental Frequency: 2462 MHz				
2485.61	H	47.69	-2.56	45.13	Peak	74	54	-28.87	212	1
2483.50	H	35.59	-2.56	33.03	Ave	74	54	-20.97	212	1
2489.35	V	52.19	-2.54	49.65	Peak	74	54	-24.35	234	1
2483.50	V	35.58	-2.56	33.02	Ave	74	54	-20.98	234	1

Modulation Standard: IEEE 802.11g(6Mbps)

Channel 1						Fundamental Frequency: 2412 MHz				
Frequency (MHz)	Ant-Pol H/V	Meter Reading	Corrected Factor	Result (dBuV/m)	Remark	Limit@3m (dBuV/m)		Margin (dB)	Table (Deg.)	Ant High (m)
						Peak	Ave.			
2389.54	H	54.34	-2.92	51.42	Peak	74	54	-22.58	222	1
2390.00	H	34.95	-2.92	32.03	Ave	74	54	-21.97	222	1
2389.34	V	56.02	-2.92	53.10	Peak	74	54	-20.90	241	1
2390.00	V	39.22	-2.92	36.30	Ave	74	54	-17.70	241	1
Channel 11						Fundamental Frequency: 2462 MHz				
2483.78	H	54.69	-2.56	52.13	Peak	74	54	-21.87	215	1
2483.50	H	36.69	-2.56	34.13	Ave	74	54	-19.87	215	1
2483.46	V	58.88	-2.56	56.32	Peak	74	54	-17.68	238	1
2483.50	V	41.93	-2.56	39.37	Ave	74	54	-14.63	238	1

Notes:

1. Result = Meter Reading + Factor
2. Factor = Antenna Factor + Cable Loss – Amplifier
3. The resolution bandwidth of test receiver/spectrum analyzer is 1 MHz and video bandwidth is 3 MHz for Peak detection at frequency above 1GHz.
4. The resolution bandwidth of test receiver/spectrum analyzer is 1MHz and video bandwidth is 10Hz for Average detection at frequency above 1GHz



Test Date : Jun. 21, 2009  
 Temperature : 26  
 Humidity : 58%  
 Atmospheric Pressure : 1023 hPa  
 Adapter : AD661F0916BLF

Modulation Standard: IEEE 802.11n, HT20 (6.5Mbps)

Channel 1						Fundamental Frequency: 2412 MHz				
Frequency (MHz)	Ant-Pol H/V	Meter Reading	Corrected Factor	Result (dBuV/m)	Remark	Limit@3m (dBuV/m)		Margin (dB)	Table (Deg.)	Ant High (m)
						Peak	Ave.			
2389.74	H	48.05	-2.92	45.13	Peak	74	54	-28.87	220	1
2390.00	H	36.23	-2.92	33.31	Ave	74	54	-20.69	220	1
2389.32	V	52.93	-2.92	50.01	Peak	74	54	-23.99	237	1
2390.00	V	34.95	-2.92	32.03	Ave	74	54	-21.97	237	1
Channel 11						Fundamental Frequency: 2462 MHz				
2483.36	H	53.99	-2.56	51.43	Peak	74	54	-22.57	208	1
2483.50	H	33.99	-2.56	31.43	Ave	74	54	-22.57	208	1
2483.45	V	55.69	-2.56	53.13	Peak	74	54	-20.87	242	1
2483.50	V	35.69	-2.56	33.13	Ave	74	54	-20.87	242	1

Modulation Standard: IEEE 802.11n, HT40 (13.5Mbps)

Channel 3						Fundamental Frequency: 2422 MHz				
Frequency (MHz)	Ant-Pol H/V	Meter Reading	Corrected Factor	Result (dBuV/m)	Remark	Limit@3m (dBuV/m)		Margin (dB)	Table (Deg.)	Ant High (m)
						Peak	Ave.			
2389.06	H	54.94	-2.92	52.02	Peak	74	54	-21.98	224	1
2390.00	H	36.25	-2.92	33.33	Ave	74	54	-20.67	224	1
2389.65	V	58.53	-2.92	55.61	Peak	74	54	-18.39	230	1
2390.00	V	38.30	-2.92	35.38	Ave	74	54	-18.62	230	1
Channel 9						Fundamental Frequency: 2452 MHz				
2484.11	H	58.71	-2.56	56.15	Peak	74	54	-17.85	211	1
2483.50	H	38.89	-2.56	36.33	Ave	74	54	-17.67	211	1
2483.65	V	62.80	-2.56	60.24	Peak	74	54	-13.76	233	1
2483.50	V	43.59	-2.56	41.03	Ave	74	54	-12.97	233	1

Notes:

1. Result = Meter Reading + Factor
2. Factor = Antenna Factor + Cable Loss – Amplifier
3. The resolution bandwidth of test receiver/spectrum analyzer is 1 MHz and video bandwidth is 3 MHz for Peak detection at frequency above 1GHz.
4. The resolution bandwidth of test receiver/spectrum analyzer is 1MHz and video bandwidth is 10Hz for Average detection at frequency above 1GHz



## 9. Power Spectral Density

### 9.1 Test Limit

The Maximum of Power Spectral Density Measurement is 8dBm.

### 9.2 Test Procedures

- The transmitter output was connected to spectrum analyzer.
- The spectrum analyzer's resolution bandwidth were set at 3KHz RBW and 30KHz VBW as that of the fundamental frequency. Set the sweep time=span/3KHz.
- The power spectral density was measured and recorded.
- The Sweep time is allowed to be longer than span/3KHz for a full response of the mixer in the spectrum analyzer.

### 9.3 Test Setup Layout

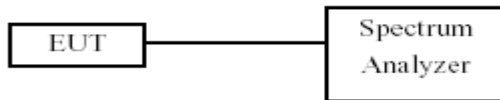

### 9.4 Measurement equipment

Instrument/Ancillary	Model No.	Manufacturer	Serial No.	Calibration Date	Valid Date
Spectrum Analyzer	FSP40	R&S	10047	2009/03/26	2010/03/25



## 9.5 Test Result and Data

Test Date: Jul. 20, 2009

Temperature: 26

Atmospheric pressure: 1012 hPa

Humidity: 64%

Modulation Standard	Channel	Frequency (MHz)	Maximum Power Density of 3 kHz Bandwidth (dBm)	
			ANT R	ANT L
802.11b (11Mbps)	01	2412	-9.1	-8.49
	06	2437	-11.91	-12.19
	11	2462	-11.66	-8.78
802.11g (6Mbps)	01	2412	-15.91	-15.74
	06	2437	-16.05	-15.67
	11	2462	-15.54	-15.77

Modulation Standard	Channel	Frequency (MHz)	Maximum Power Density of 3 kHz Bandwidth (dBm)		
			Ant1	Ant2	Ant1+Ant2
802.11n HT20 (6.5Mbps)	01	2412	-20.17	-21.06	-17.58
	06	2437	-19.3	-20.82	-16.82
	11	2462	-21.34	-20.31	-17.78
802.11n HT40 (13.5Mbps)	03	2422	-21.34	-22.07	-18.68
	06	2437	-22.05	-21.44	-18.72
	09	2452	-20.93	-21.32	-18.11



Modulation Standard: 802.11b (11Mbps), Ant1  
Channel: 01

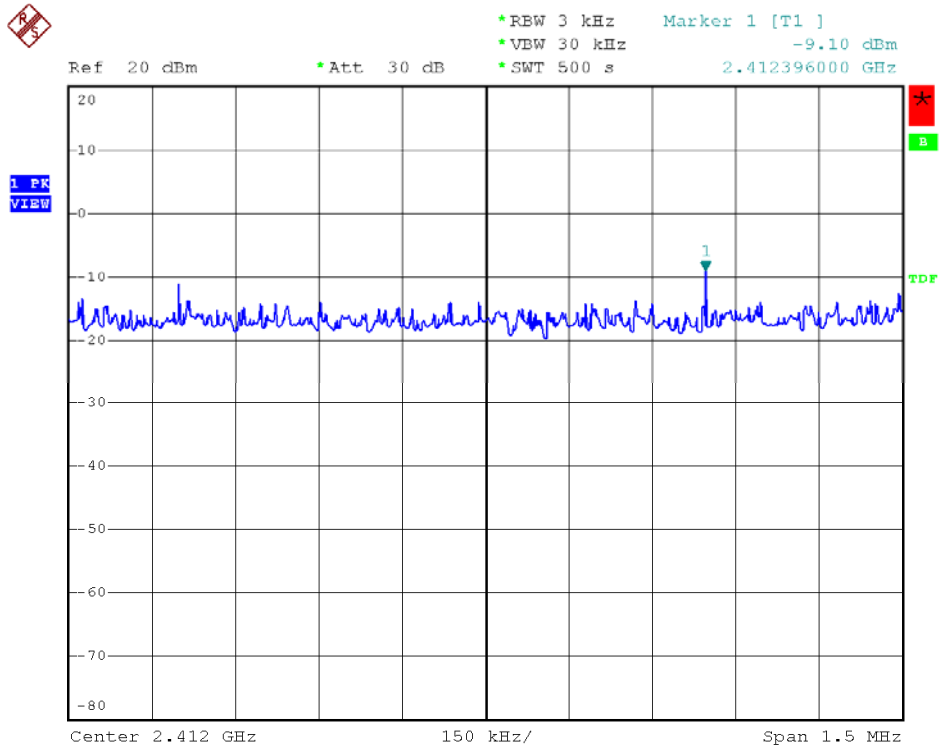

Modulation Standard: 802.11b (11Mbps), Ant2  
Channel: 01

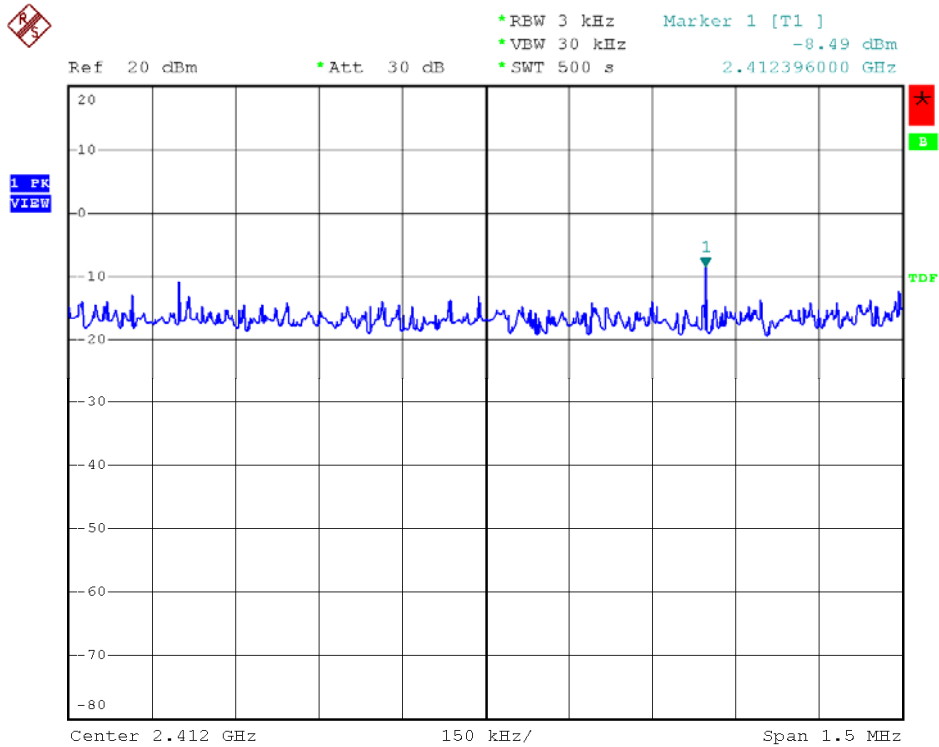



Modulation Standard: 802.11b (11Mbps), Ant1  
Channel: 06

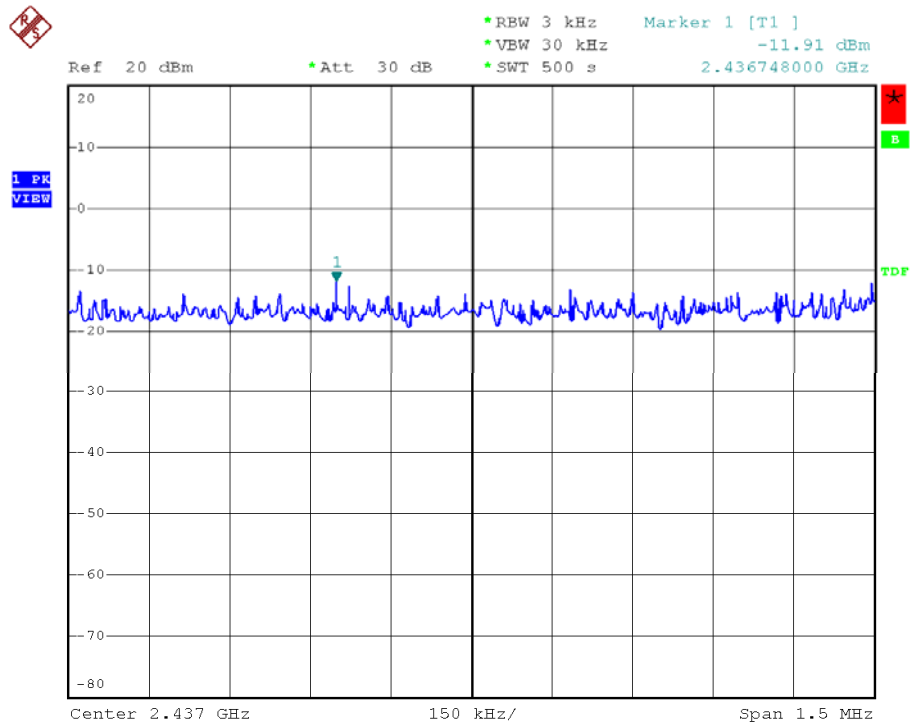

Modulation Standard: 802.11b (11Mbps), Ant2  
Channel: 06

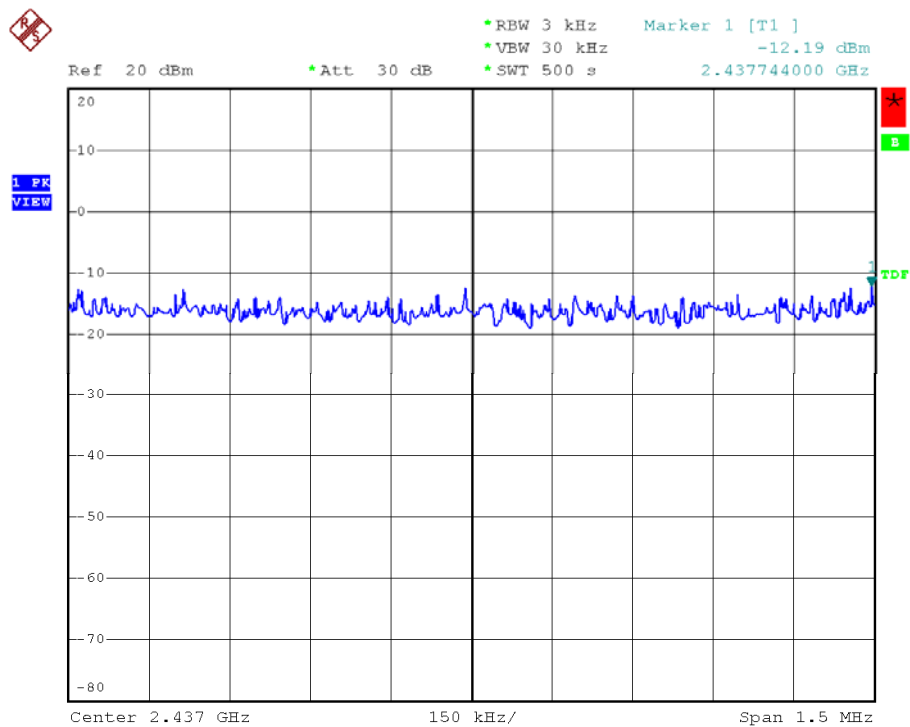







Modulation Standard: 802.11g (6Mbps), Ant1  
Channel: 01

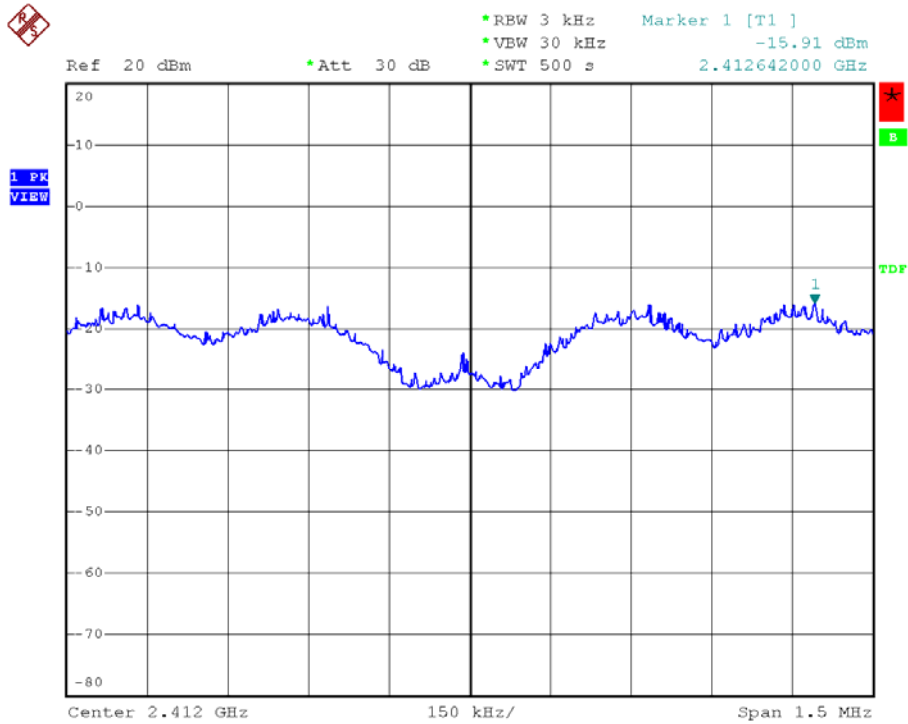

Modulation Standard: 802.11g (6Mbps), Ant2  
Channel: 01

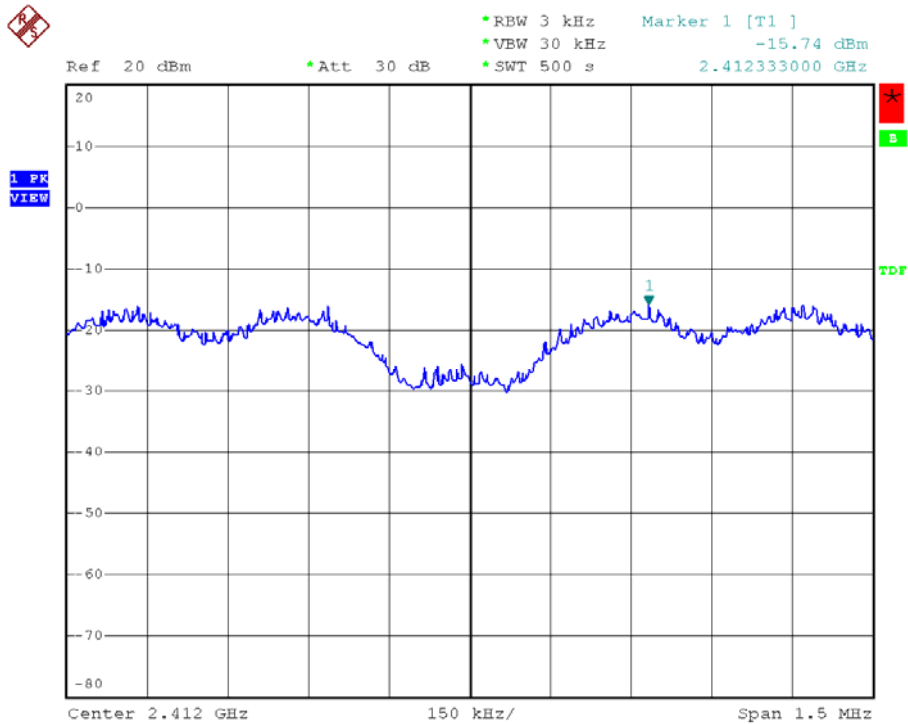



Modulation Standard: 802.11g (6Mbps), Ant1  
Channel: 06

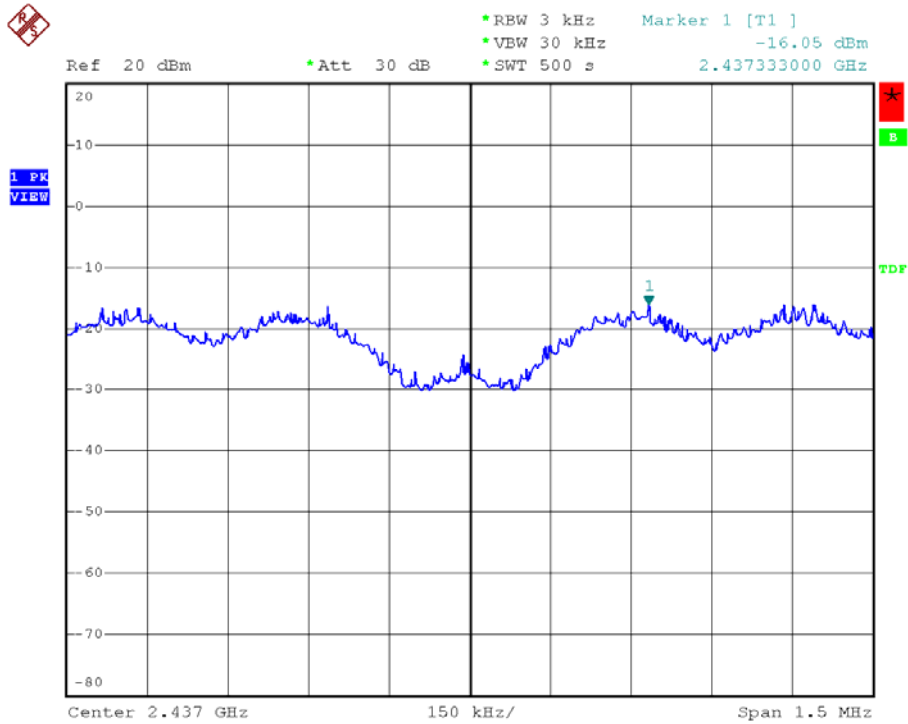

Modulation Standard: 802.11g (6Mbps), Ant2  
Channel: 06

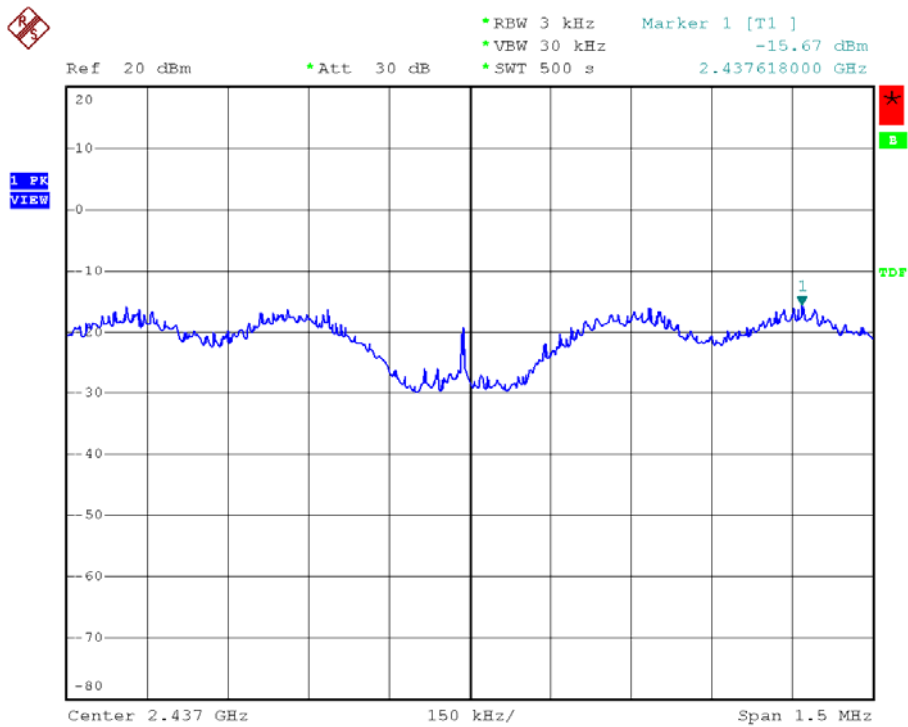





Modulation Standard: 802.11n, HT20 (6.5Mbps), Ant1  
Channel: 01

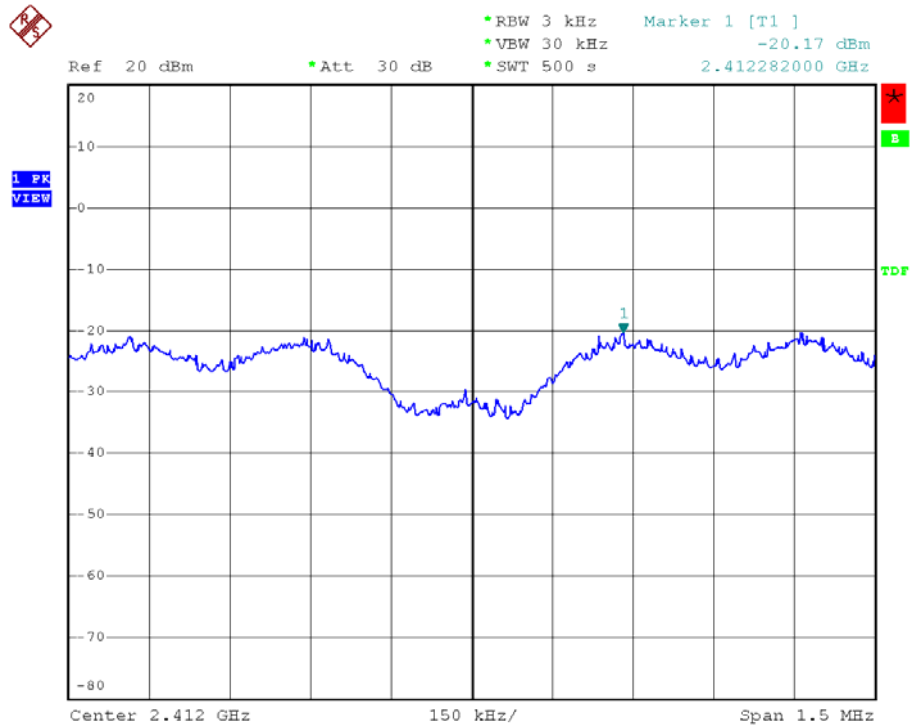

Modulation Standard: 802.11n, HT20 (6.5Mbps), Ant2  
Channel: 01

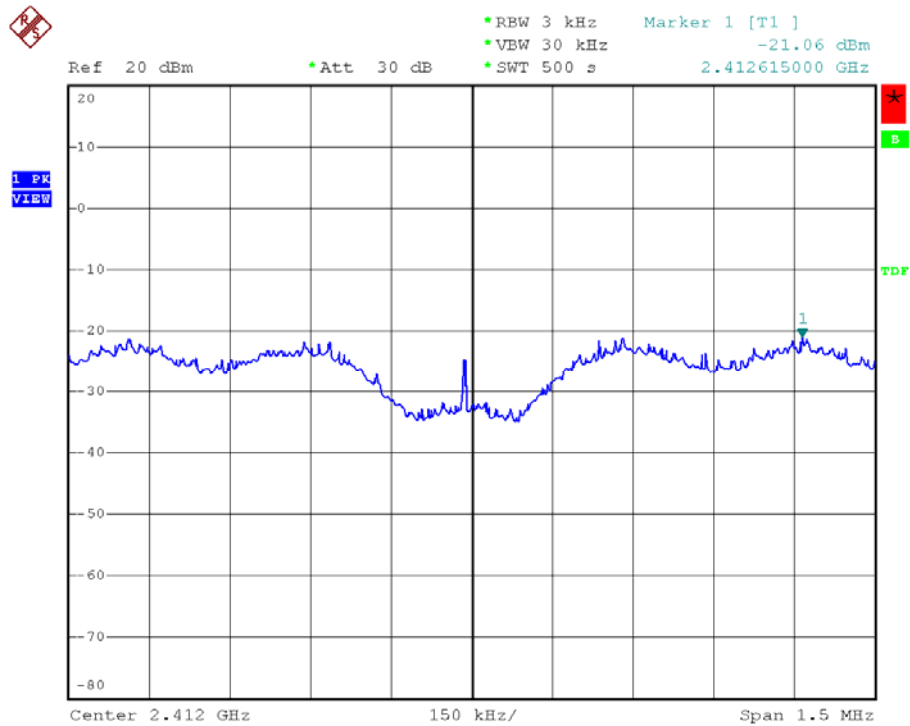



Modulation Standard: 802.11n, HT20 (6.5Mbps), Ant1  
Channel: 06

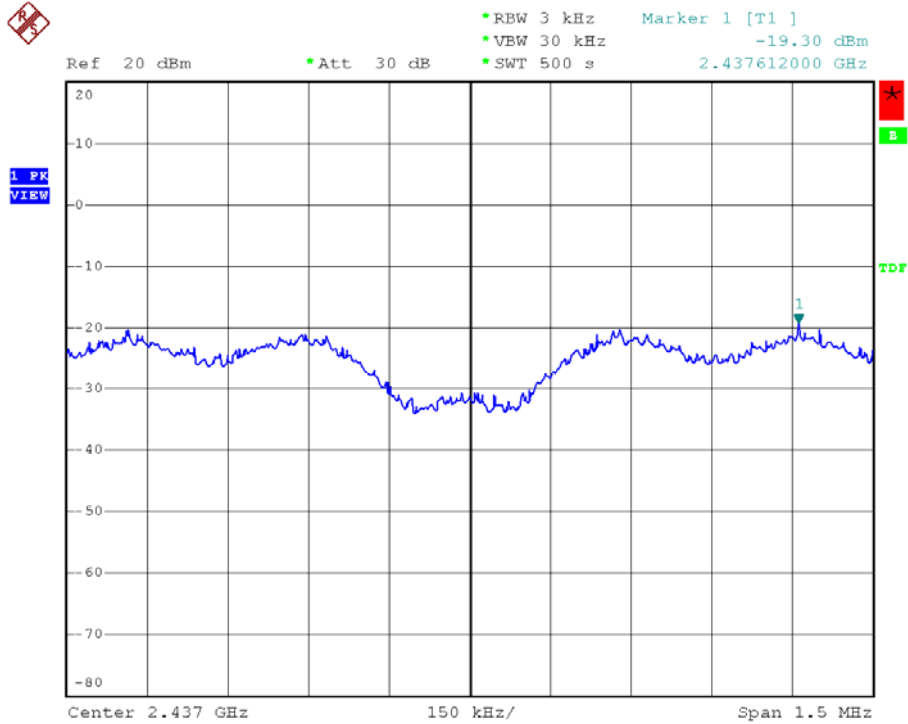

Modulation Standard: 802.11n, HT20 (6.5Mbps), Ant2  
Channel: 06

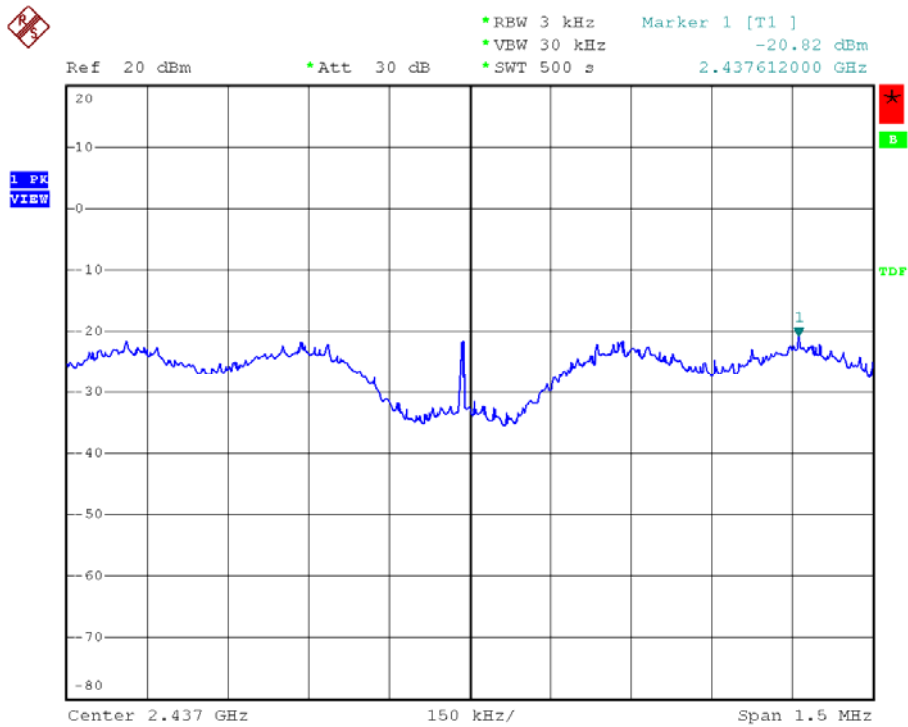



Modulation Standard: 802.11n, HT20 (6.5Mbps), Ant1  
Channel: 11

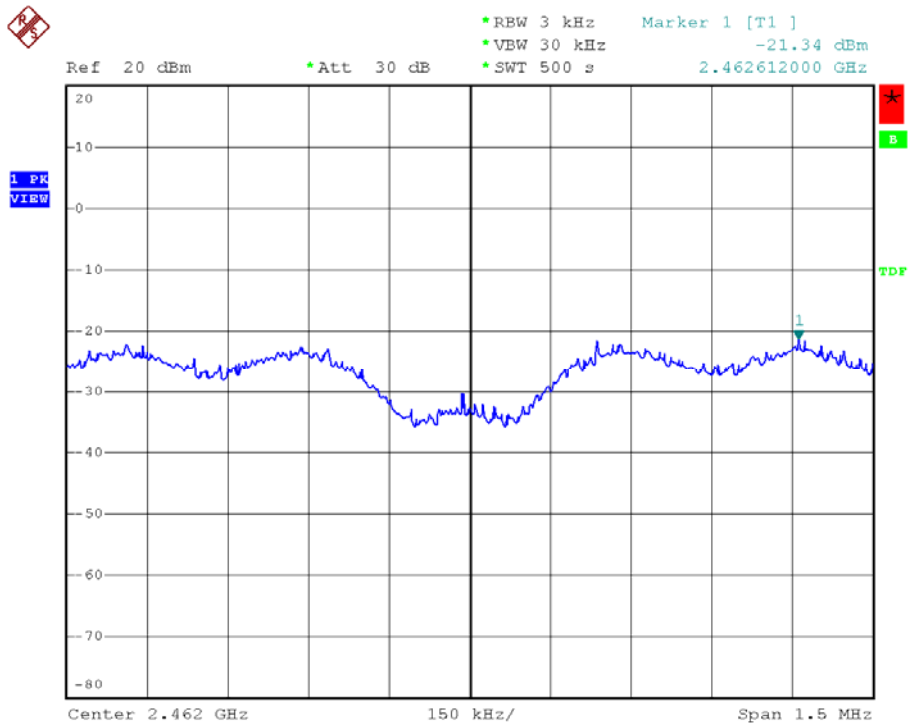

Modulation Standard: 802.11n, HT20 (6.5Mbps), Ant2  
Channel: 11

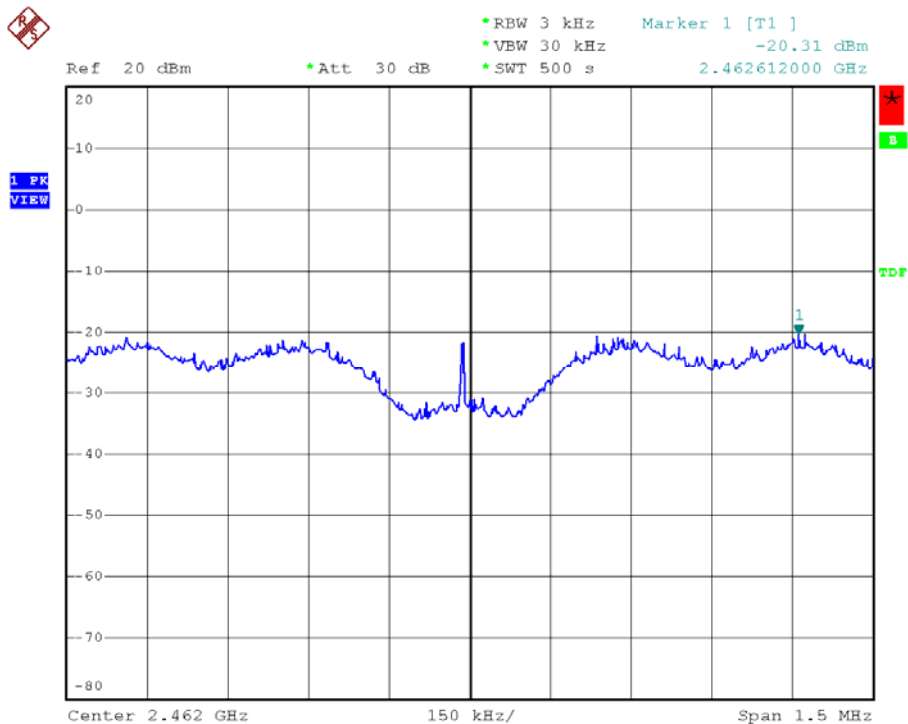



Modulation Standard: 802.11n, HT40 (13.5Mbps), Ant1  
Channel: 03

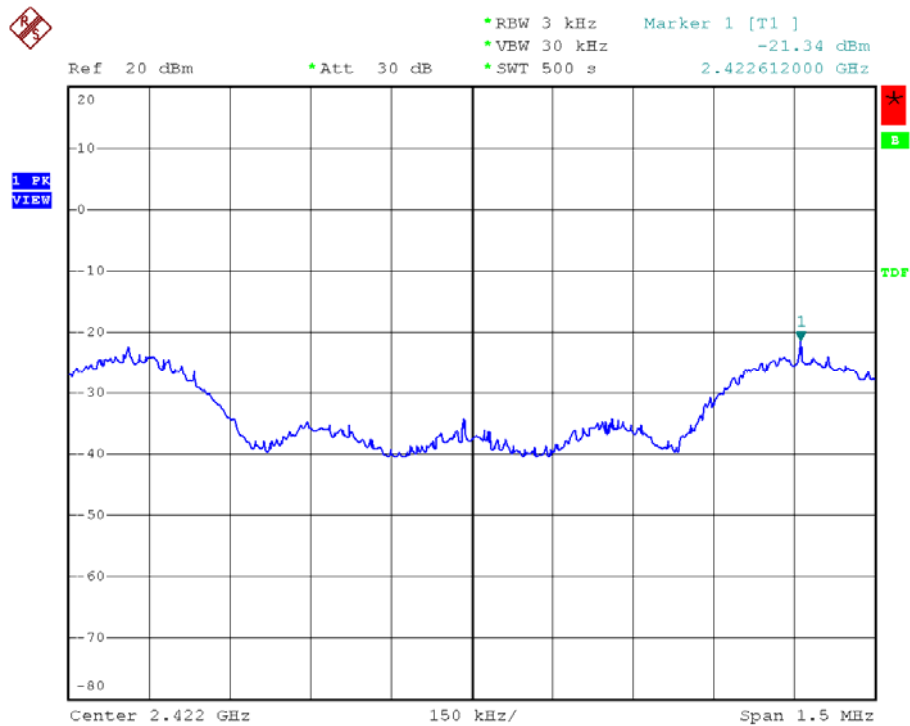

Modulation Standard: 802.11n, HT40 (13.5Mbps), Ant2  
Channel: 03

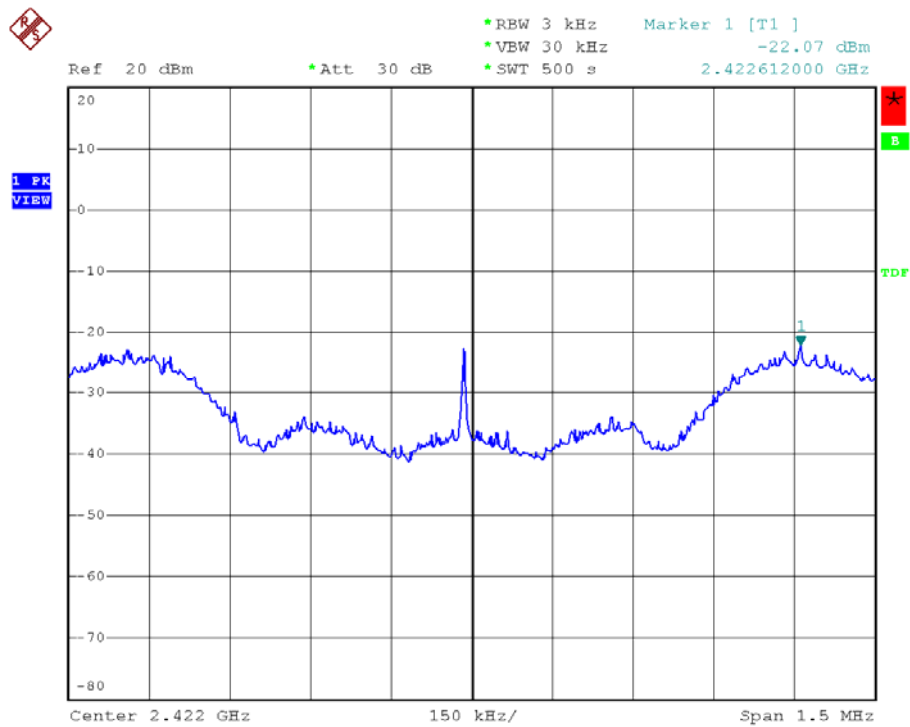



Modulation Standard: 802.11n, HT40 (13.5Mbps), Ant1  
Channel: 06

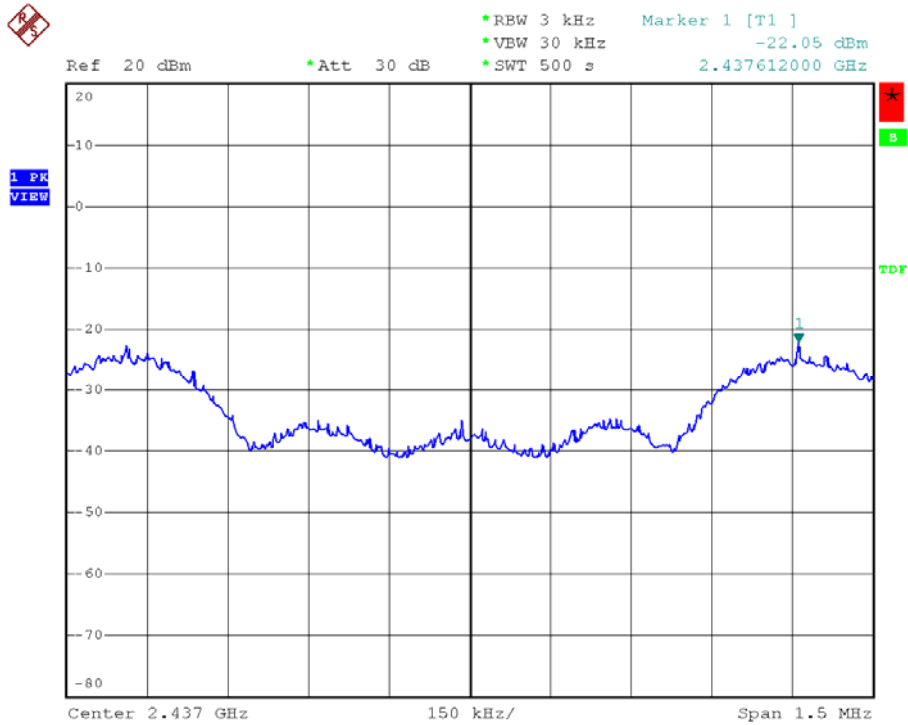

Modulation Standard: 802.11n, HT40 (13.5Mbps), Ant2  
Channel: 06

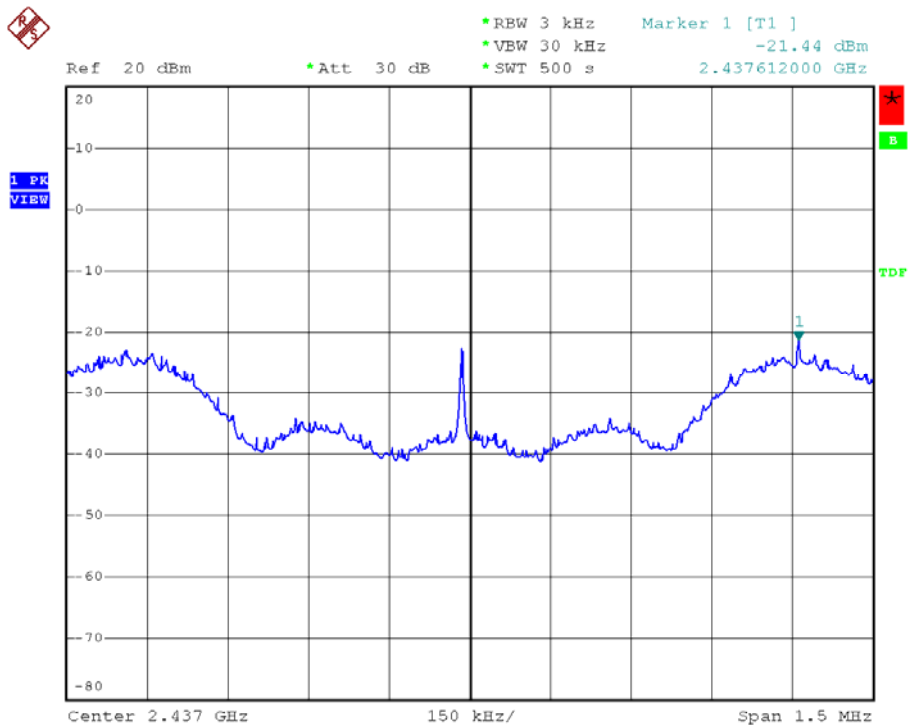





Modulation Standard: 802.11n, HT40 (13.5Mbps), Ant1  
Channel: 09

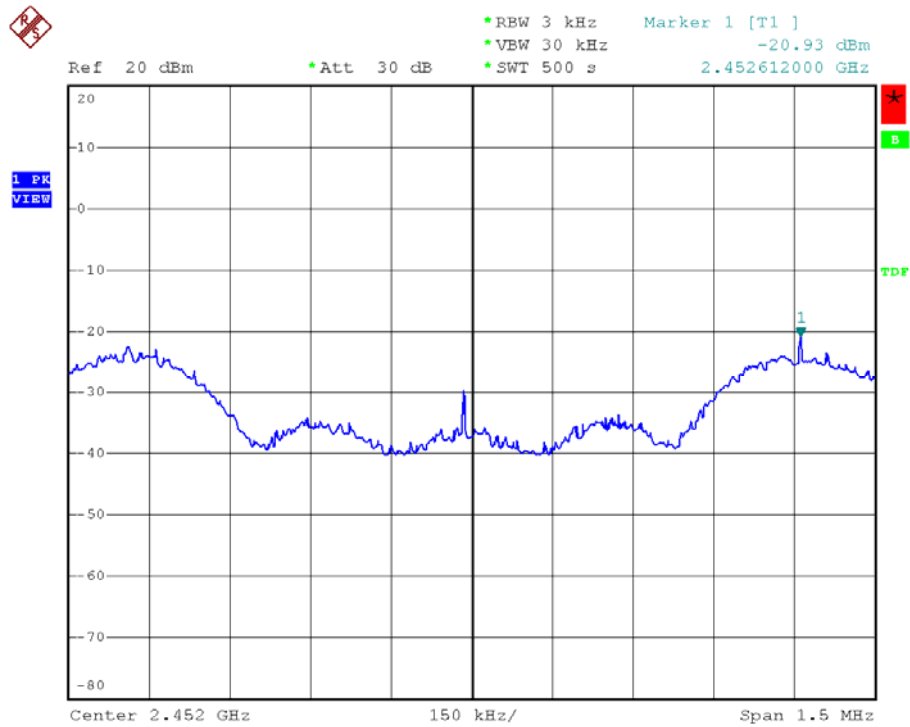

Modulation Standard: 802.11n, HT40 (13.5Mbps), Ant2  
Channel: 06

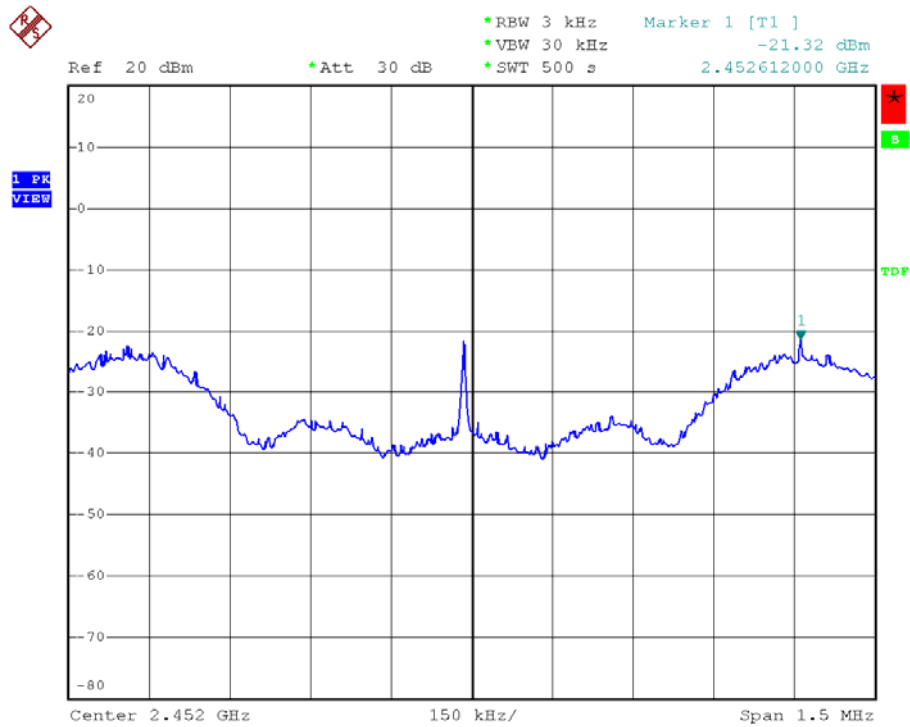



## 10. Restricted Bands of Operation

Only spurious emissions are permitted in any of the frequency bands listed below:

MHz	MHz	MHz	GHz
0.09000 – 0.11000	16.42000 – 16.42300	399.9 – 410.0	4.500 – 5.250
0.49500 – 0.505**	16.69475 – 16.69525	608.0 – 614.0	5.350 – 5.460
2.17350 – 2.19050	16.80425 – 16.80475	960.0 – 1240.0	7.250 – 7.750
4.12500 – 4.12800	25.50000 – 25.67000	1300.0 – 1427.0	8.025 – 8.500
4.17725 – 4.17775	37.50000 – 38.25000	1435.0 – 1626.5	9.000 – 9.200
4.20725 – 4.20775	73.00000 – 74.60000	1645.5 – 1646.5	9.300 – 9.500
6.21500 – 6.21800	74.80000 – 75.20000	1660.0 – 1710.0	10.600 – 12.700
6.26775 – 6.26825	108.00000 – 121.94000	1718.8 – 1722.2	13.250 – 13.400
6.31175 – 6.31225	123.00000 – 138.00000	2200.0 – 2300.0	14.470 – 14.500
8.29100 – 8.29400	149.90000 – 150.05000	2310.0 – 2390.0	15.350 – 16.200
8.36200 – 8.36600	156.52475 – 156.52525	2483.5 – 2500.0	17.700 – 21.400
8.37625 – 8.38675	156.70000 – 156.90000	2655.0 – 2900.0	22.010 – 23.120
8.41425 – 8.41475	162.01250 – 167.17000	3260.0 – 3267.0	23.600 – 24.000
12.29000 – 12.29300	167.72000 – 173.20000	3332.0 – 3339.0	31.200 – 31.800
12.51975 – 12.52025	240.00000 – 285.00000	3345.8 – 3358.0	36.430 – 36.500
12.57675 – 12.57725	322.00000 – 335.40000	3600.0 – 4400.0	Above 38.6
13.36000 – 13.41000			

\*\* : Until February 1, 1999, this restricted band shall be 0.490-0.510 MHz

### 10.1 Labeling Requirement

The device shall bear the following statement in a conspicuous location on the device:

This device complies with part 15 of the FCC Rules. Operation is subject to the following two conditions: (1) This device may not cause harmful interference, and (2) this device must accept any interference received, including interference that may cause undesired operation.